

VACON[®]
AC DRIVES

OPTE9
DUAL PORT ETHERNET OPTION BOARD
INSTALLATION MANUAL

VACON[®]

TABLE OF CONTENTS

Document: DPD01583E

Release date : 7/6/17

1.	Safety	4
1.1	Danger	4
1.2	Warnings	5
1.3	Earthing and earth fault protection	6
2.	OPTE9 Dual Port Ethernet - General	7
2.1	New features	8
3.	OPTE9 Ethernet board technical data	9
3.1	General	9
3.2	Cables	9
4.	Layout and connections	10
4.1	Layout and connections	10
4.2	LED Indications	11
4.2.1	Profinet IO	12
4.3	Ethernet devices	13
4.3.1	Human to machine	13
4.3.2	machine to machine	14
4.4	Connections and wiring	15
4.4.1	Topology: Star	15
4.4.2	Topology: Daisy Chain	15
4.4.3	Topology: Ring	16
4.5	ACD (Address Conflict Detection)	20
5.	Installation	21
5.1	Installation in VACON® NX	22
5.2	Installation in VACON® 20	24
5.2.1	Frames MI1, MI2, MI3	24
5.2.2	Frames MI4, MI5	27
5.3	Installation in VACON® 20 X and 20 CP	31
5.4	Installation in VACON® 100 family	33
5.5	installation in VACON® 100 X	36
5.6	PC Tools	39
5.6.1	PC tool support	39
5.6.2	Updating the OPTE9 option board firmware with VACON® Loader	40
5.6.3	PC Tools for VACON® NX / NCIPConfig	43
5.6.4	PC Tools for VACON® NX / NCDrive	45
5.6.5	PC Tools for VACON® 100 family and VACON® 20 / VACON® Live	48
6.	Commissioning	51
6.1	Option board menu	51
6.1.1	Option board parameters	51
6.1.2	Option board monitoring values	53
6.1.3	Communication protocol	53
6.1.4	IP Mode	54
6.1.5	IP Address	54
6.1.6	Communication timeout	54
6.1.7	Profinet IO - Name of Station	55
6.1.8	EIP Input and Output instance	55
6.1.9	EIP Product code offset	55
6.1.10	Mode	55
6.1.11	MAC Address	56
6.1.12	Modbus Unit Identifier	57
6.2	Communication mode	57

6.3	Control and status word monitoring values	57
7.	Modbus TCP / Modbus UDP	58
7.1	Modbus UDP vs TCP.....	59
7.2	Modbus communications.....	61
7.3	Data addresses in Modbus messages	62
7.3.1	Modbus memory map	62
7.3.2	Modbus data mapping.....	63
7.4	Modbus communication and connection timeout	74
7.5	Quick setup.....	75
7.6	Modbus - example messages	76
7.6.1	Example 1 - Write process data.....	76
7.6.2	Example 2 - Read process data	77
7.6.3	Example 3 - Exception response	78
8.	PROFINET IO	79
8.1	PROFIdrive 4.1 profile	79
8.2	PROFIdrive 4.1 state machine.....	80
8.3	PROFINET IO process communication	82
8.3.1	Choosing telegram type	82
8.3.2	Telegram types	82
8.3.3	Telegram building blocks	89
8.3.4	Quick setup.....	93
8.4	PROFIdrive IO parameters	94
8.4.1	Parameters of the PROFIdrive.....	94
8.4.2	Vendor-specific PROFIdrive parameters.....	96
8.4.3	PROFIdrive signal numbers	97
8.4.4	User specific record data.....	100
8.4.5	Base Mode Parameter Access Model.....	101
8.4.6	Parameter responses	105
8.4.7	Drive parameter access using application ID.....	109
8.4.8	Parameter channel examples	109
8.5	PROFINET IO communications and connection timeout.....	116
8.6	Alarm system	117
9.	EtherNet/IP.....	119
9.1	General information.....	119
9.1.1	Overview	119
9.1.2	AC/DC Drive Profile.....	119
9.1.3	EDS file	119
9.1.4	LED functionality	120
9.1.5	Explicit Messaging	121
9.1.6	EtherNet/IP communication and connection timeout.....	126
9.2	Common Industrial Objects implemented by OPTE9	128
9.2.1	CIP Objects	128
9.2.2	Vendor Specific Objects	153
9.3	Assembly instances implemented by OPTE9	161
9.3.1	CIP I/O Assembly instances for AC/DC Drive	161
9.3.2	Vendor-specific I/O Assembly Instances	166
9.3.3	Mapping of Standard Output Assemblies onto VACON® data.....	178
9.3.4	Mapping of VACON® data onto Standard Input Assemblies	179
9.4	EtherNet/IP connection example	181
10.	Fault tracing.....	182
10.1	Typical fault conditions	182
10.2	Other fault conditions	183
11.	APPENDIX 1 - PROCESS DATA.....	184

12.	APPENDIX 2 - CONTROL AND STATUS WORD	185
12.1	Control Word bit description	185
12.2	Status Word Descriptions	187
12.3	Control word bit support in drives	188
12.4	Status word bit support in drives.....	189
13.	APPENDIX 3 - EXAMPLE WITH SIEMENS PLC	190
13.1	Siemens STEP 7	190
13.2	Siemens TIA Portal	198
14.	APPENDIX 4 - EXAMPLE WITH SIEMENS SIMATIC PDM	205
15.	APPENDIX 5 - FIELDBUS PARAMETRISATION	209
15.1	Fieldbus control and basic reference selection	209
15.2	Controlling Fieldbus Parameter	210
15.3	Torque control parametrization	211
16.	APPENDIX 6 - LWIP LICENCE	212
17.	Appendix 7 - Fieldbus option board communication	213
17.1	Requirements for communication modes	213
17.2	Fiedlbus communication mode features and limitations	214
17.3	Normal fieldbus communication	214
17.4	Fast fieldbus communication	215
17.5	Normal Extended Mode	215
18.	APPENDIX 8 - parameters for application developers	216



1. SAFETY

This manual contains clearly marked cautions and warnings that are intended for your personal safety and to avoid any unintentional damage to the product or connected appliances.

Read the information included in cautions and warnings carefully.

The cautions and warnings are marked as follows:

Table 1. Warning signs

	= DANGER! Dangerous voltage
	= WARNING or CAUTION
	= Caution! Hot surface

1.1 DANGER



The **components of the power unit are live** when the drive is connected to mains potential. Coming into contact with this voltage is **extremely dangerous** and may cause death or severe injury.



The **motor terminals U, V, W and the brake resistor terminals are live** when the AC drive is connected to mains, even if the motor is not running.



After disconnecting the AC drive from the mains, **wait** until the indicators on the keypad go out (if no keypad is attached, see the indicators on the cover). Wait 5 more minutes before doing any work on the connections of the drive. Do not open the cover before this time has expired. After expiration of this time, use a measuring equipment to absolutely ensure that no voltage is present. **Always ensure absence of voltage before starting any electrical work!**



The control I/O-terminals are isolated from the mains potential. However, the **relay outputs and other I/O-terminals may have a dangerous control voltage** present even when the AC drive is disconnected from mains.



Before connecting the AC drive to mains make sure that the front and cable covers of the drive are closed.



During a ramp stop (see the Application Manual), the motor is still generating voltage to the drive. Therefore, do not touch the components of the AC drive before the motor has completely stopped. Wait until the indicators on the keypad go out (if no keypad is attached, see the indicators on the cover). Wait additional 5 minutes before starting any work on the drive.

1.2 WARNINGS



The AC drive is meant for **fixed installations only**.



Do not perform any measurements when the AC drive is connected to the mains.



The **earth leakage current** of the AC drives exceeds 3.5mA AC. According to standard EN61800-5-1, **a reinforced protective ground connection** must be ensured. See Chapter 1.3.



If the AC drive is used as a part of a machine, the **machine manufacturer is responsible** for providing the machine with a **supply disconnecting device** (EN 60204-1).



Only **spare parts** delivered by VACON® can be used.



At power-up, power break or fault reset **the motor will start immediately** if the start signal is active, unless the pulse control for Start/Stop logic has been selected. Furthermore, the I/O functionalities (including start inputs) may change if parameters, applications or software are changed. Disconnect, therefore, the motor if an unexpected start can cause danger.



The **motor starts automatically** after automatic fault reset if the auto restart function is activated. See the Application Manual for more detailed information.



Prior to measurements on the motor or the motor cable, disconnect the motor cable from the AC drive.



Do not touch the components on the circuit boards. Static voltage discharge may damage the components.



Check that the **EMC level** of the AC drive corresponds to the requirements of your supply network.

1.3 EARTHING AND EARTH FAULT PROTECTION



CAUTION!

The AC drive must always be earthed with an earthing conductor connected to the earthing terminal marked with .

The earth leakage current of the drive exceeds 3.5mA AC. According to EN61800-5-1, one or more of the following conditions for the associated protective circuit must be satisfied:

- a) The protective conductor must have a cross-sectional area of at least 10 mm² Cu or 16 mm² Al, through its total run.
- b) Where the protective conductor has a cross-sectional area of less than 10 mm² Cu or 16 mm² Al, a second protective conductor of at least the same cross-sectional area must be provided up to a point where the protective conductor has a cross-sectional area not less than 10 mm² Cu or 16 mm² Al.
- c) Automatic disconnection of the supply in case of loss of continuity of the protective conductor.

The cross-sectional area of every protective earthing conductor which does not form part of the supply cable or cable enclosure must, in any case, be not less than:

- 2.5mm² if mechanical protection is provided or
- 4mm² if mechanical protection is not provided.

The earth fault protection inside the AC drive protects only the drive itself against earth faults in the motor or the motor cable. It is not intended for personal safety.

Due to the high capacitive currents present in the AC drive, fault current protective switches may not function properly.



Do not perform any voltage withstand tests on any part of the AC drive. There is a certain procedure according to which the tests must be performed. Ignoring this procedure can cause damage to the product.

NOTE! You can download the English and French product manuals with applicable safety, warning and caution information from <http://drives.danfoss.com/knowledge-center/technical-documentation/>.

REMARQUE Vous pouvez télécharger les versions anglaise et française des manuels produit contenant l'ensemble des informations de sécurité, avertissements et mises en garde applicables sur le site <http://drives.danfoss.com/knowledge-center/technical-documentation/>.

2. OPTE9 DUAL PORT ETHERNET - GENERAL

The VACON® AC drives can be connected to the Ethernet networks using the VACON® OPTE9 Dual Port Ethernet fieldbus option board (OPTE9). The drives can be daisy chained by utilizing two Ethernet ports of OPTE9. The option board supports PROFINET IO, Ethernet/IP, Modbus TCP and Modbus UDP fieldbus protocols. “EtherNet/IP™ is a trademark of ODVA, Inc. The following network topologies are supported. See details in Chapter 4.4 “Connections and wiring”.

- Star
- Daisy chain
- Ring

Every appliance connected to an Ethernet network has two identifiers: a MAC address and an IP address. The MAC address (Address format: xx:xx:xx:xx:xx:xx) is unique for each appliance and cannot be changed. The Ethernet board’s MAC address can be found on the sticker attached to the board.

In a local network, IP addresses can be defined by the user as long as all the units connected to the network are given the same network portion of the address. Overlapping IP addresses cause conflicts between appliances. For more information about setting IP addresses, see Chapter 6.

Table 2. List of abbreviations used in this document

Abbreviation	Explanation
ACD	Address Conflict Detection
CRC	Cyclic Redundancy Check is an error-detecting code commonly used in fieldbusses to detect accidental changes to raw data.
DHCP	Dynamic Host Configuration Protocol is used for dynamical resolving of network configuration parameters like an IP address.
FB	Fieldbus
GW	Gateway
HI	Upper 8/16 bits in a 16/32 bit value.
LO	Lower 8/16 bits in a 16/32 bit value.
LWIP	Light weight TCP/IP protocol stack for embedded systems.
Modbus TCP / Modbus UDP	Simple and vendor-neutral communication protocol intended for monitoring and controlling of field devices.
PDI	Process data in (Profinet IO)
PDO	Process data out (Profinet IO)
PHY(X)	Ethernet physical interface X, where X represents the number of interface
PLC	Programmable Logic Controller
PNU	Parameter number (Profinet IO)
Profinet IO	Profinet is a standard for industrial automation in Ethernet network. Profinet IO describes the exchange of data between controllers and field devices.
RPM	Revolutions per minute
RSTP	Rapid Spanning Tree Protocol
TCP	Transmission Control Layer provides reliable, ordered and error-checked delivery of data streams between computers that are connected to a local area network.

Table 3. List of data types used in this document

Type name	Bit size	Explanation
INT8	8	Signed short integer
UINT8	8	Unsigned short integer
INT16	16	Signed integer
UINT16	16	Unsigned integer
INT32	32	Signed long integer
UINT32	32	Unsigned long integer
FLOAT32	32	32-bit floating point
STRING3	24	Three byte string
STRING5	40	Five byte string

2.1 NEW FEATURES

The following table shows the new features that are added in the OPTE9 Dual Port Ethernet's firmware versions.

Table 4. New features

New feature	Firmware version
EtherNet/IP protocol	V004
Ethernet ring support (RSTP)	V004
Address Conflict Detection (ACD)	V004
Media Redundancy Protocol (MRP)	V006
Simple Network Management Protocol (SNMP)	V006
LLDP-MIB, LLDP-EXT-DOT3-MIB, LLDP-EXT-PNO-MIB	V006
EDD files SIMATIC PDM	V006
Fast communication modes in VACON® NXP	V007
PROFINET IO Alarms	V007

3. OPTE9 ETHERNET BOARD TECHNICAL DATA

3.1 GENERAL

Table 5. Technical data

General	Board name	OPTE9
Ethernet connections	Interface	Two RJ-45 connectors
	Transfer cable	Shielded Twisted Pair (STP) CAT5e
Communications	Speed	10 / 100 Mb
	Duplex	half / full
	Default IP-address	By default the board is in DHCP mode
Protocol	Modbus TCP, Modbus UDP, Profinet I/O, EtherNet/IP	
Environment	Ambient operating temperature	-10°C...50°C
	Storing temperature	-40°C...70°C
	Humidity	<95%, no condensation allowed
	Altitude	Max. 1000 m
	Vibration	0.5 G at 9...200 Hz
Safety	Fulfills EN50178 standard	

3.2 CABLES

For connecting the OPTE9 devices, use only Ethernet cables that meet at least the requirements of category 5 (CAT5) according to EN 50173 or ISO/IEC 11801.

4. LAYOUT AND CONNECTIONS

The VACON® OPTE9 Dual Port Ethernet option board is connected to the Ethernet bus using the standard RJ45 connectors (1 and 2). The communication between the control board and the AC drive takes place through a standard VACON® Interface Board Connector.

4.1 LAYOUT AND CONNECTIONS

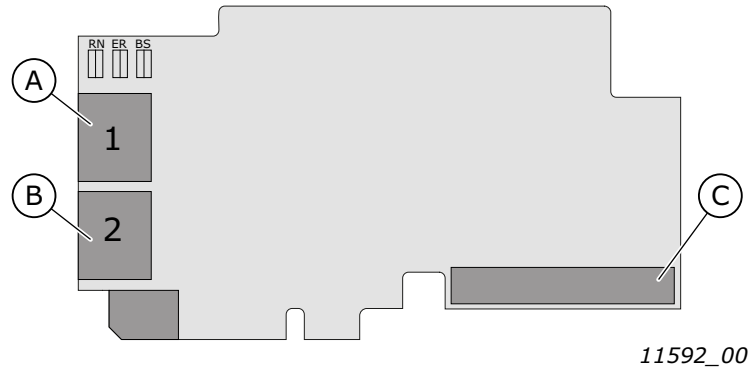

A	Ethernet connector	C	Interface Board connector
B	Ethernet connector		

Figure 1. The OPTE9 option board

Table 6. OPTE9 Ethernet ports

Ethernet port	Description
1	Ethernet port 1 (PHY1)
2	Ethernet port 2 (PHY2)

4.2 LED INDICATIONS

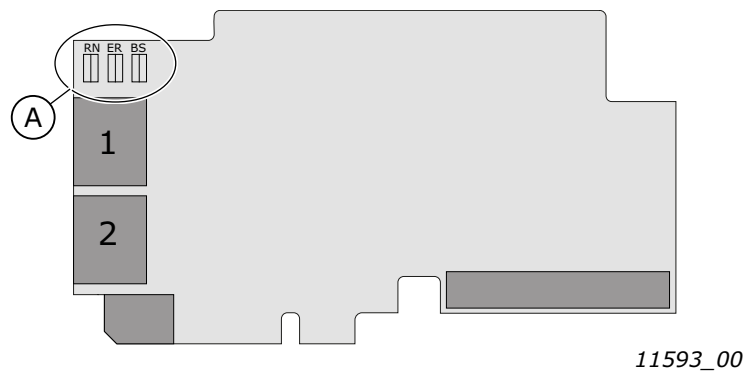





A	LED indications	
---	-----------------	--

Figure 2. The OPTe9 option board LED indicators

The table below lists possible LED combinations and their meanings. When the EtherNet/IP is active, the option board follows CIP standard for LED indications. Therefore, the indications described in Table 7 do not apply. See Chapter 9.1.4 "LED functionality".

Table 7. List of possible LED combinations

LED combinations	Description
	No power. All LEDs are OFF.
	Option board firmware is corrupted or its software is missing. ER is blinking (0.25s ON / 0.25s OFF)
	Option board failure. Option board is not operational. BS is red and ER is possibly blinking (2.5s ON / 2.5s OFF)
	Option board is operational.
	Protocol is ready for communications. RN is blinking (2.5s ON / 2.5s OFF).

LED combinations	Description
	Protocol is communicating.
	Protocol communication fault. ER is blinking to indicate a fault. RN is blinking to indicate that protocol is again ready for communications.
	Protocol is communicating with an active fault. ER is blinking.
	Duplicate IP address detected. RN is blinking.
	Profinet IO only! In node flashing test all three LEDs are blinking.

4.2.1 PROFINET IO

When using the "Node Flashing Test" function, you can determine to which device you are directly connected. For example, in Siemens S7, by using the menu command "PLC > Diagnostics/Setting > Node Flashing Test..." you can identify the station directly connected to the PG/PC if all three LEDs are flashing green.

4.3 ETHERNET DEVICES

The common-use cases of Ethernet devices are 'human to machine' and 'machine to machine'. The basic features of these two cases are presented in the pictures below.

4.3.1 HUMAN TO MACHINE

Requirements:

- Graphical User Interface
- Relatively slow communication in use

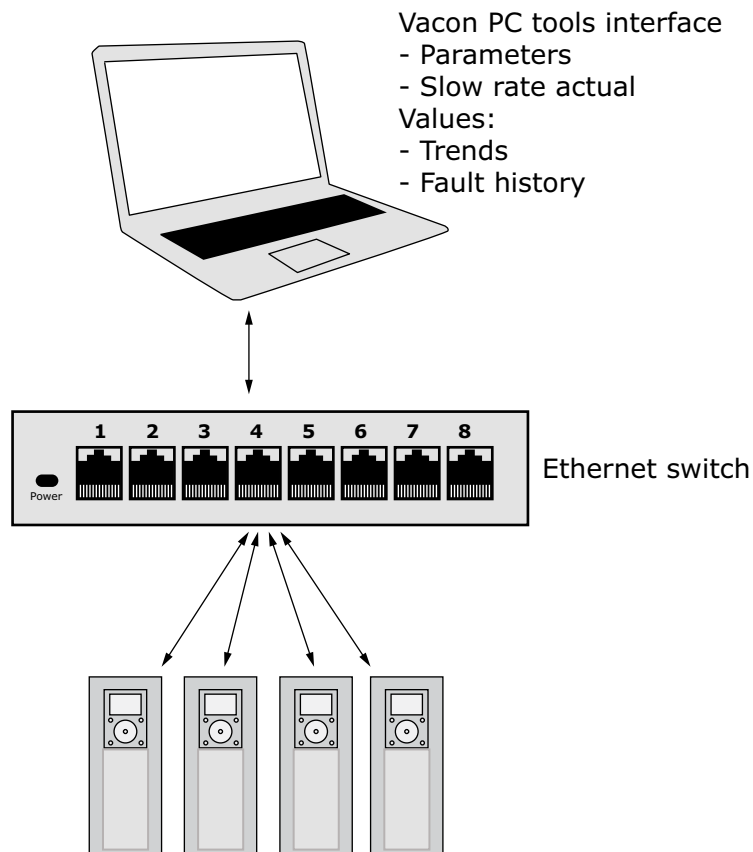

Figure 3. Ethernet , Human to Machine

NOTE! NCDrive can be used in VACON[®] NXS and NXP drives via Ethernet. VACON[®] Live can be used with VACON[®] 100 family.

NOTE! The Ethernet connection to VACON[®] 20, VACON[®] 20 X and VACON[®] 20 CP via the OPTE9 Dual Port Ethernet is not yet supported.

4.3.2 MACHINE TO MACHINE

Requirements:

- Industrial environment
- Fast communication in use

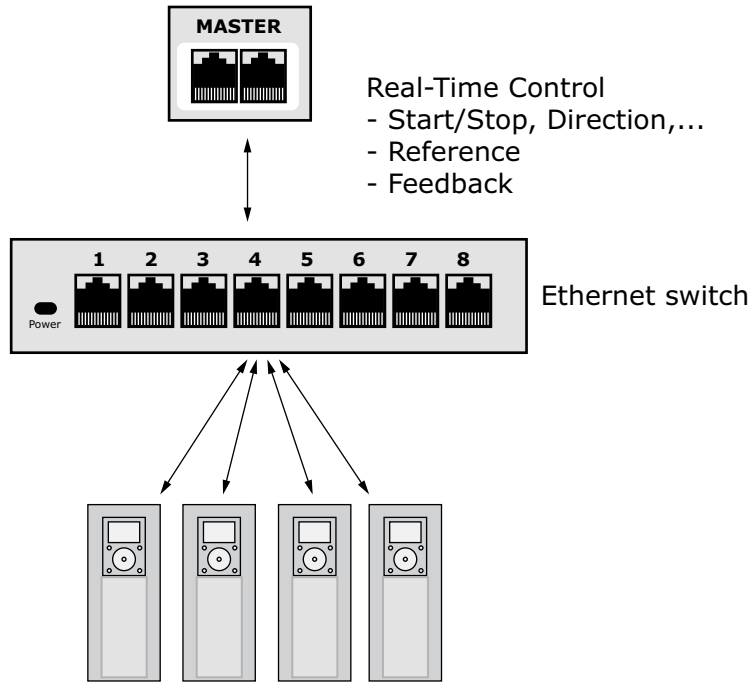

11595_uk

Figure 4. Ethernet, Machine to Machine

4.4 CONNECTIONS AND WIRING

The OPTE9 has two Ethernet ports and an embedded switch. The option board is seen in network as a single device as it has only one MAC and IP address. This configuration enables three different topologies:

- Star (see Chapter 4.4.1)
- Daisy chain (see Chapter 4.4.2)
- Ring (see Chapter 4.4.3)

Each of these topologies has their own advantages and disadvantages. When designing the network you must carefully consider the risks and benefits against the cost of the selected topology.

The OPTE9 supports 10/100Mb speeds in both Full- and Half-duplex modes. However, real-time process control requires the Full-duplex mode and the 100-megabit speed. The boards must be connected to the Ethernet network with a Shielded Twisted Pair (STP) CAT-5e cable (or better).

Use only industrial standard components in the network and avoid complex structures to minimize the length of response time and the amount of incorrect dispatches. Because of the internal switch in OPTE9, it does not matter in what port of the option board the Ethernet cables are connected to.

4.4.1 TOPOLOGY: STAR

In star network, all the devices are connected to the same switch(es). This topology reduces the damage caused by single cable failure. It would affect only to a single drive instead of them all. In this setup, a drive will receive only broadcast/multicast messages and messages directed to this drive.

Only one port from the OPTE9 can be connected to a switch in the star topology. Connecting both ports to switch(es) will cause an involuntary Ethernet ring which, in this setup, will break the network.

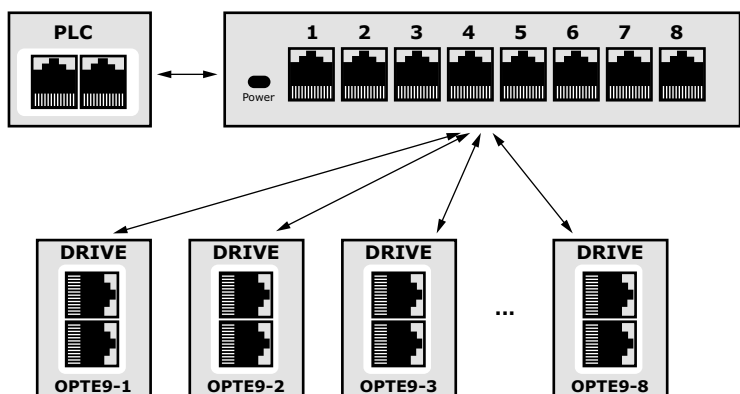

11660_uk

Figure 5. Star Topology

4.4.2 TOPOLOGY: DAISY CHAIN

The daisy-chaining allows you to reduce the costs for cabling and networking equipment such as switches. The maximum number of daisy-chained boards is 32. This restriction comes from the average latency (20 to 40 microseconds) per Ethernet switch. The drawback in the daisy chain topology is that it increases traffic in all except the last drive. The first drive in the daisy chain sees

all the traffic in the chain. Also damage to a single cable will drop all drives behind it from the network.

Both in daisy chain topology and in star topology, the last drive's port must not be connected back to the same line. This would cause an involuntary Ethernet ring which will break the network.

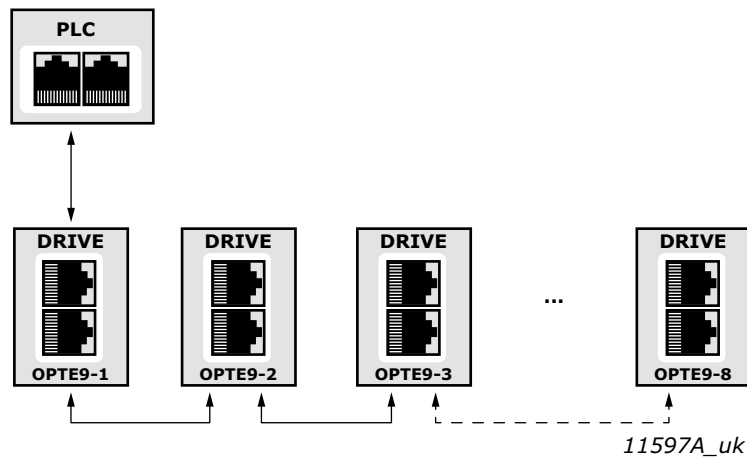

Figure 6. Daisy chain topology

4.4.3 TOPOLOGY: RING

In some cases it is possible to use OPTE9 in a ring topology. These cases are explained in Chapter 4.4.3.1 and Chapter 4.4.3.2. The ring topology gains the same reduced cabling cost as the daisy chain topology, but decreases the damage caused by a single cable failure.

4.4.3.1 Rapid Spanning Tree Protocol (RSTP)

To use the RSTP protocol, add a managed Ethernet switch that supports the RSTP protocol. If a single link is broken, the RSTP switch will notice this and start sending data from the PLC to both directions effectively creating two daisy chains. When the link has been repaired, the switch will notice this too and reverts back to normal operating mode. Compared to the star topology, the ring topology adds more network traffic to almost all drives. Damage to two cables will always create an isolated subnetwork.

In the RSTP configuration, one of the ports in the switch is "Designated Port" (DP) and the other "Alternative Port" (AP). When the network is functioning properly, the traffic flows through the designated port. Only the BPDU (Bridge Protocol Data Unit) packets are transferred through the AP port. The BPDU packets are used by the switch to determine if the network is working properly. If it detects that the BPDU packets do not go through the ring, it will change the alternative port to a second designated port. Now the switch will send packets to both directions in the broken ring (see Figure 8).

Each designated port has a list of MAC addresses which are behind that port. Only frames directed to the device in the MAC list are forwarded into that designated port. The broadcast and multicast frames are sent to all designated ports.

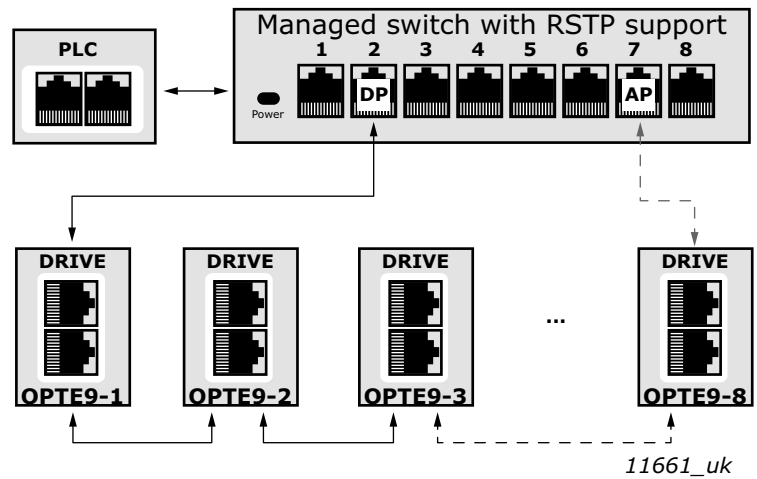

Figure 7. Ring topology

In the example below, the Ethernet communication will be interrupted to device number three and other devices after that when the link is broken. The Fieldbus communication maybe faulted when the link is broken, but when the switch enables the second designated port, the connections can be reopened. In the RSTP protocol, it generally takes few seconds before the second designated port will be activated. This depends on the BPDU exchange cycle, which is 2 seconds by default.

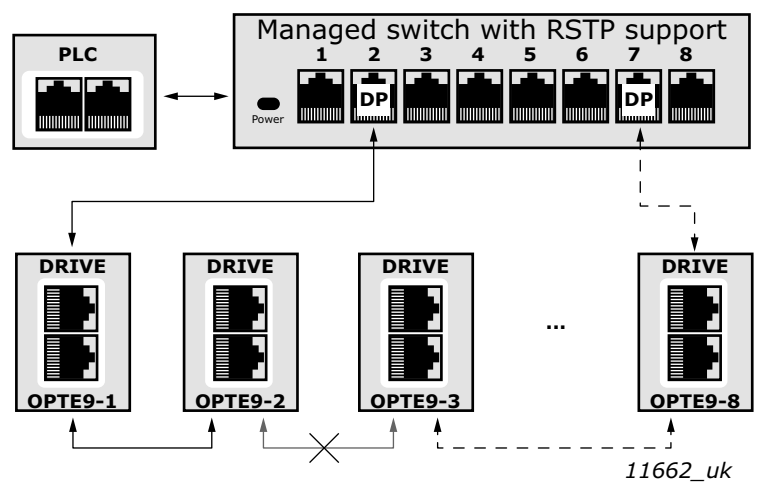

Figure 8. Ring topology: Error in network

NOTE! The OPTE9 switch itself does not implement the RSTP protocol, so the network will always need a third party switch to support it.

Configuration example

The screenshots below (Figure 9, Figure 10) show one example of configuring the RSTP in the switch (in this case an EtherWAN switch). Port two is the designated port and port one is the alternative port. The PLC was connected to port nine (the laptop taking the screenshots was in port 16). When configuring your switch, refer to the switch manufacturer's manual.

The screenshot shows the configuration interface for a Management Switch. On the left is a navigation tree with categories like System, Port, Switching, Trunking, STP / Ring, VLAN, QoS, SNMP, 802.1x, and Other Protocols. Under STP / Ring, 'Global Configuration' is selected. The main area displays a table with RSTP settings.

Status	
Bridge ID	800000e0b32503a9
Designated Root	800000e0b32503a9
Reg Root ID	
Root Port	0
Root Path Cost	0
Current Max Age (sec)	20
Current Hello Time (sec)	1
Current Forward Delay (sec)	15
Hold Time (sec)	
Topology Change Count	
Time Since Last Topology Change	
Setting	
Spanning Tree Protocol	Enable ▾
Bridge Priority (0..61440)	32768
Hello Time (1..10 sec)	1
Max Age (6..40 sec)	20
Forward Delay (4..30 sec)	15
STP Version	RSTP ▾

Update Setting

11663_uk

Figure 9. EtherWAN Switch RSTP Configuration example

The screenshot shows the 'RSTP Port Setting' configuration page. It features a table listing 16 ports with their status, priority, path cost, link type, and edge port status. Below the table is a detailed 'RSTP Port Configuration' for port 1.

Port	Port Status	Priority	Path Cost	Point to Point Link	Edge Port
1	Disabled(Discarding)	128	200000	point-to-point	Disabled
2	Designated(Forwarding)	128	200000	point-to-point	Disabled
3	Disabled(Discarding)	128	200000	shared	Disabled
4	Disabled(Discarding)	128	200000	shared	Disabled
5	Disabled(Discarding)	128	200000	shared	Disabled
6	Disabled(Discarding)	128	200000	shared	Disabled
7	Disabled(Discarding)	128	200000	shared	Disabled
8	Disabled(Discarding)	128	200000	shared	Disabled
9	Designated(Forwarding)	128	200000	point-to-point	Disabled
10	Disabled(Discarding)	128	200000	shared	Disabled
11	Disabled(Discarding)	128	200000	shared	Disabled
12	Disabled(Discarding)	128	200000	shared	Disabled
13	Disabled(Discarding)	128	200000	shared	Disabled
14	Disabled(Discarding)	128	200000	shared	Disabled
15	Disabled(Discarding)	128	200000	shared	Disabled
16	Designated(Forwarding)	128	200000	point-to-point	Disabled

Port	Priority(Granularity 16)	Admin. Path Cost	Point to Point Link	Edge Port
1 ▾	128	200000	Enable ▾	Disable ▾

Update Setting

11664_uk

Figure 10. EtherWAN Switch RSTP Configuration example - Port Settings

4.4.3.2 Media Redundancy Protocol (MRP)

The MRP is designed to react deterministically on a cable failure. This makes it suitable to be used in process automation. One of the nodes in the network has the role of Media Redundancy Master (MRM), which observes and controls the ring topology in order to react to network faults. Usually this device is PLC or network switch.

The other nodes in the network are called Media Redundancy Clients (MRC), and they react on received configuration frames from the MRM and can detect link changes on its ring ports. OPTE9 supports only MRC functionality.

The MRM and MRC have two ring ports, which take one of the following states:

- DISABLED
 - All frames are dropped
- BLOCKING
 - All frames are dropped, except the following frames:
 - a) MRP frames (e.g. MRP_test and MRP_TopologyChange)
 - b) Frames specified to pass ports in "Discarding" state, e.g. LLDP frames
- FORWARDING
 - All frames are forwarded according to normal behaviour

The MRM sends MRP_Test frames in a configured time period to monitor the state of the ring topology. If the MRM receives its own MRP_Test frames (network is closed), one of the ring ports is set to FORWARDING state and the other to BLOCKED state (see Figure 11). If the MRP_Test frames are not received by the MRM (network is open), it sets both of its ring ports to FORWARDING state (see Figure 12).

The following figure shows an example of a MRP network, where the PLC acts as a MRM.

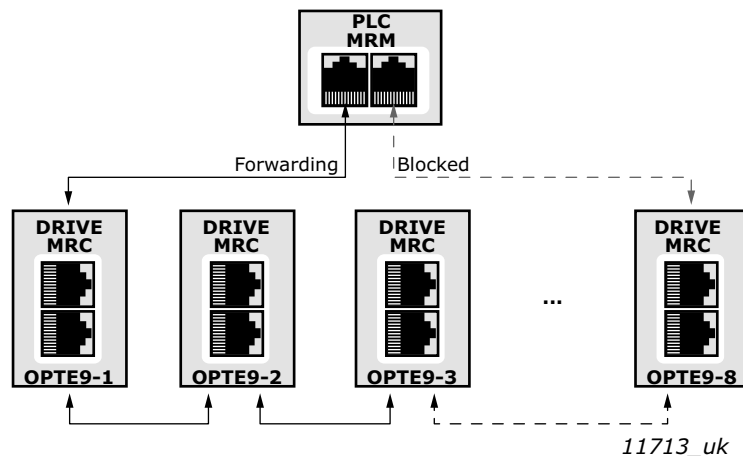

Figure 11. MRP ring: Closed network

In the example below, the Ethernet communication will be interrupted to device number three and other devices after that when the link is broken. MRP can be configured to send test frames with different time periods, depending on the maximum allowed recovery time for the network. When using PROFINET IO, the recovery time is defined as 200 ms. Therefore, if the recovery time is less than the watchdog time, the fieldbus connection is not interrupted by the cable failure.

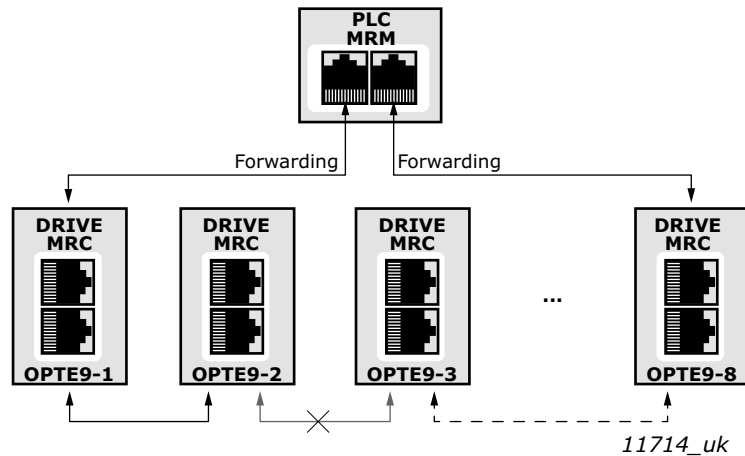

Figure 12. MRP ring: Error in network

NOTE: The OPTE9 can use MRP (as MRC) only when PROFINET IO is the selected protocol. When using MRP in a PROFINET IO network, it is suggested to set the watchdog time of each device in the ring to 200ms, as this is the time that a network of 50 nodes is guaranteed to recover. MRP is available in OPTE9 version V006 or later.

4.5 ACD (ADDRESS CONFLICT DETECTION)

The OPTE9 option board implements ACD algorithm (IETF RFC 5227). The implementation includes requirements from the EtherNet/IP protocol.

The ACD algorithm tries to actively detect if the IP address configured to this device is been used by another device in the same network. To accomplish this, ACD sends four ARP request packets when the device's Ethernet interface goes up or when its IP address changes. ACD prevents the use of the Ethernet interface until the ARP probing finishes. This delays the startup of fieldbus protocols about one second. During the delay or after it, the ACD passively checks incoming ARP messages for use of the device's IP address. If another device with the same IP address is detected, the ACD will try to defend its IP address with a single ARP message. If the other device with the same IP address also supports ACD, it should stop using the address. If not, the ACD will close the Ethernet connection and indicate the situation with LEDs. This is done according the "DefendWithPolicyB". Other policies are not supported. If the fieldbus protocol has been active, a fieldbus fault may be activated (depends on the fieldbus and drive application configuration).

5. INSTALLATION

The VACON® OPTE9 Dual Port Ethernet option board can be used with the following VACON® AC drives.

Table 8. Supported AC drives and slots

AC drive	Slots	From AC drive SW version on	From OPTE9 SW version on
VACON® NXP	D, E	NXP00002V188	V001
VACON® NXS	D, E	NXS00002V179	V001
VACON® 100 INDUSTRIAL and 100 X	D, E	FW0072V018	V003
VACON® 100 FLOW	D, E	FW0159V012	V003
VACON® 20	-	FW0107V011	V002
VACON® 20 X and CP	-	FW0117V007	V002

VACON® 100 family support

The VACON® 100 family AC drives are supported from the OPTE9 firmware version V003. The process data in VACON® 100 family AC drives is 32 bit. The 32-bit process data support is planned for later firmware release. Only 16-bit process data is supported.

EtherNet/IP support

EtherNet/IP protocol was added to OPTE9 firmware version V004. The table below shows required minimum AC drive firmware version .

Table 9. Required minimum AC drive firmware versions

AC Drive	From AC drive SW version on
VACON® NXP	NXP00002V191
VACON® NXS	NXS00002V181
VACON® 100 INDUSTRIAL and 100 X	FW0072V018
VACON® 100 FLOW	FW0159V012
VACON® 20	FW0107V012
VACON® 20 X and CP	FW0117V009

5.1 INSTALLATION IN VACON® NX

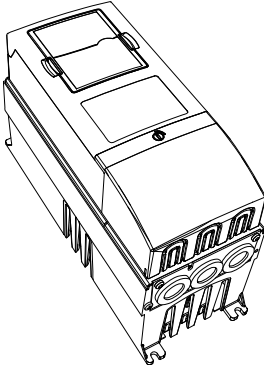
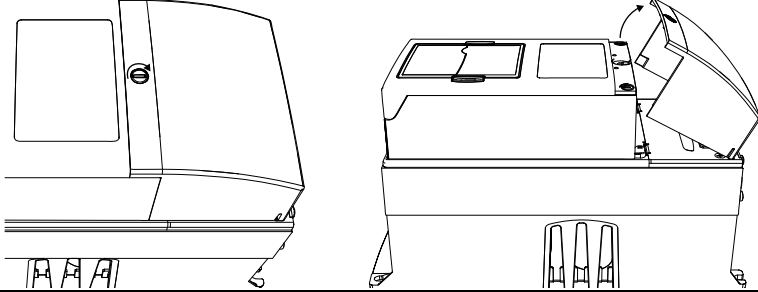
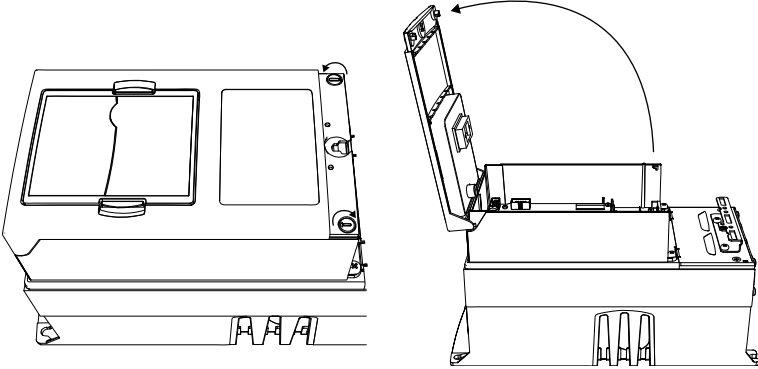

Make sure that the AC drive **is switched off** before an option or fieldbus board is changed or added!

1	<p>VACON® NX AC drive.</p> 
2	<p>Remove the cable cover.</p> 
3	<p>Open the cover of the control unit.</p> 

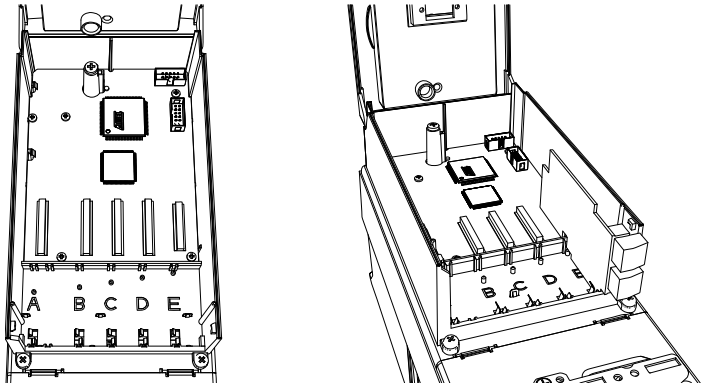
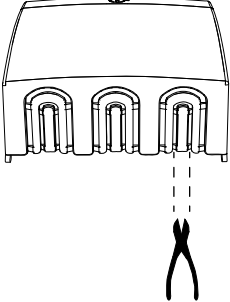
<p>4</p>	<p>Install the OPTE9 Option Board in slot D or E on the control board of the AC drive. Make sure that the grounding plate fits tightly in the clamp.</p> 
<p>5</p>	<p>Make a sufficiently wide opening for your cable by cutting the grid as wide as necessary.</p> 
<p>6</p>	<p>Close the cover of the control unit and the cable cover.</p>

5.2 INSTALLATION IN VACON® 20

5.2.1 FRAMES MI1, MI2, MI3

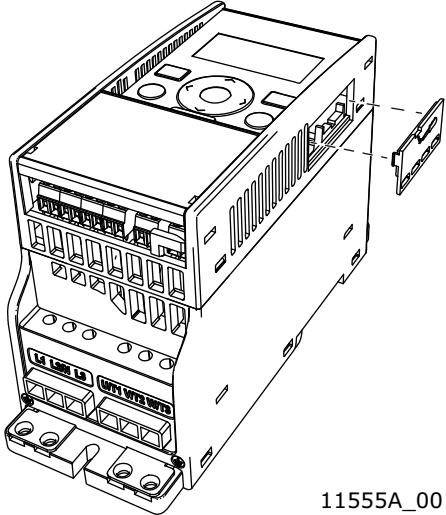
1	<p>Remove the cable connector lid from the AC drive.</p>	 <p>11555A_00</p>
----------	--	---

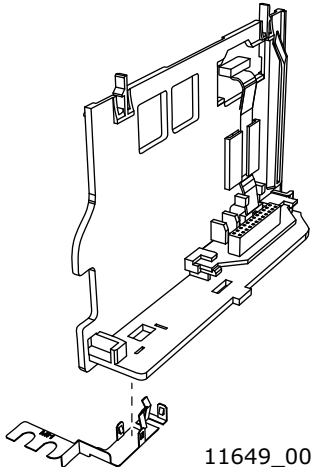
2	<p>Select a correct grounding plate and attach it to the option board mounting frame. The grounding plate is marked with the supported enclosure size.</p>	 <p>11649_00</p>
----------	--	--

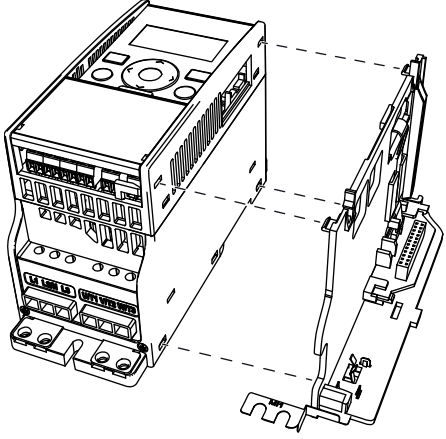
3	<p>Attach an option board mounting frame to the AC drive.</p>	 <p>11556A_00</p>
----------	---	---

4

Connect the flat cable from the option board mounting frame to V20.

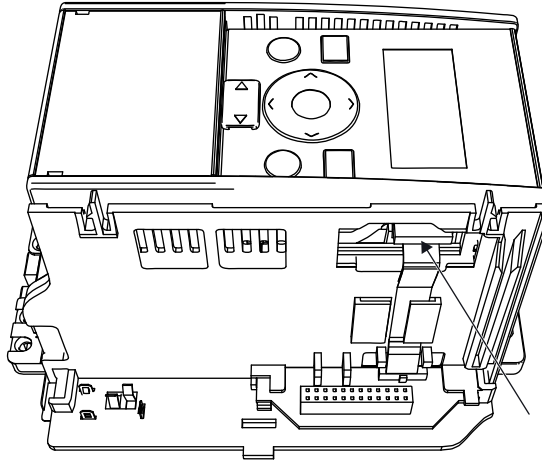

11557A_00

5

If a cable strain relief is required, attach the parts as shown in the figure.

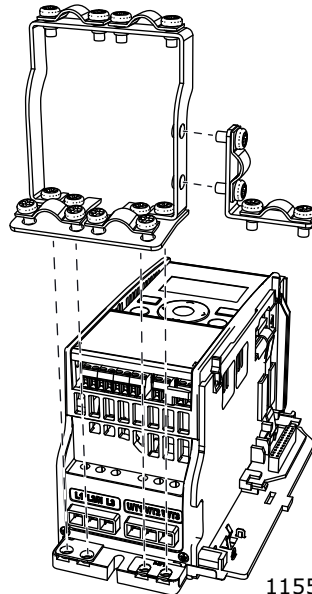

11558A_00

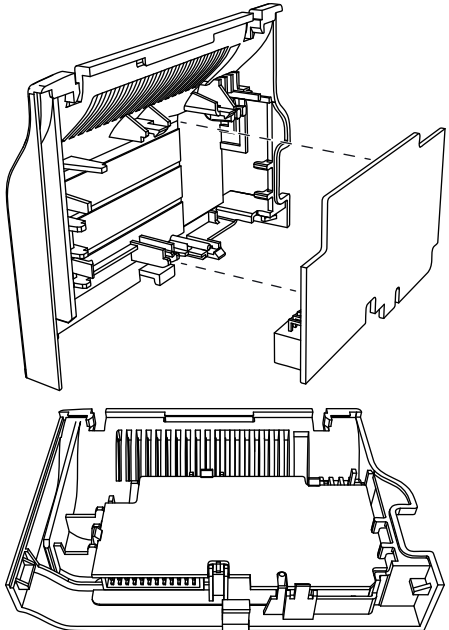
6	<p>Install the option board to the option board holder. Make sure that the option board is securely fastened.</p>	 <p style="text-align: right; margin-top: 10px;">11559A_00</p>
----------	---	--

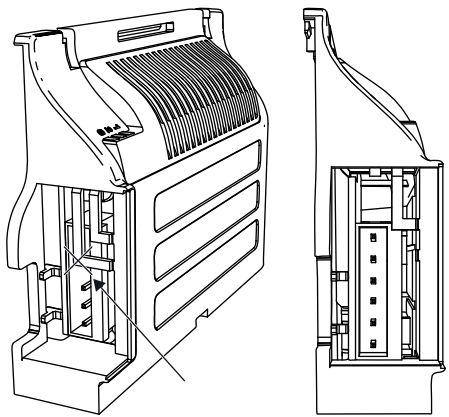
7	<p>Cut free a sufficiently wide opening for the option board connector.</p>	 <p style="text-align: right; margin-top: 10px;">11650_00</p>
----------	---	--

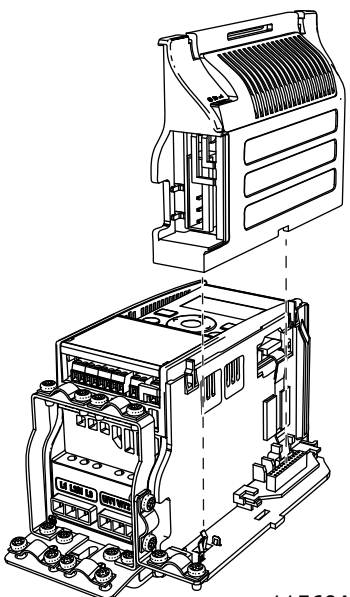
8	<p>Attach the option board cover to V20. Attach the strain relief cable clamp with screws if needed.</p>	 <p style="text-align: right; margin-top: 10px;">11560A_00</p>
----------	--	--

5.2.2 FRAMES MI4, MI5



Make sure power is disconnected before opening the V20 cover.

1

1a: For MI4: Open the cover.

11561_00

1b: For MI5: Open the cover and release the fan connector.

11562_00

2

Attach the option board support.

11563_00

3 Connect the flex cable to option board connector PCB.

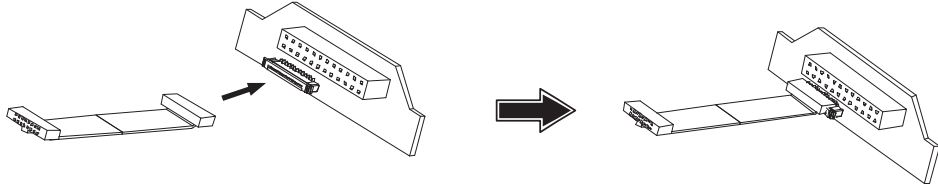

11564_00

4 Connect the option board to connector PCB.

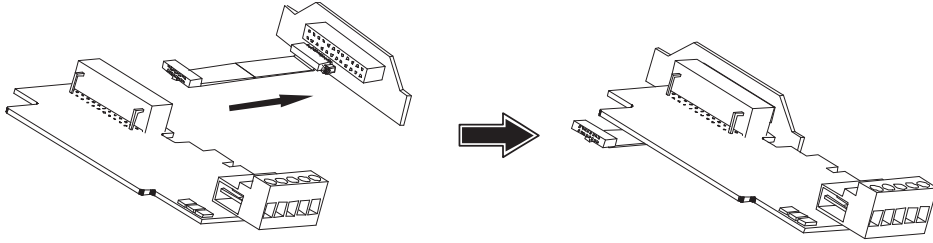

11565_00

5 Attach the option board with connector PCB to V20 and connect the flex cable.

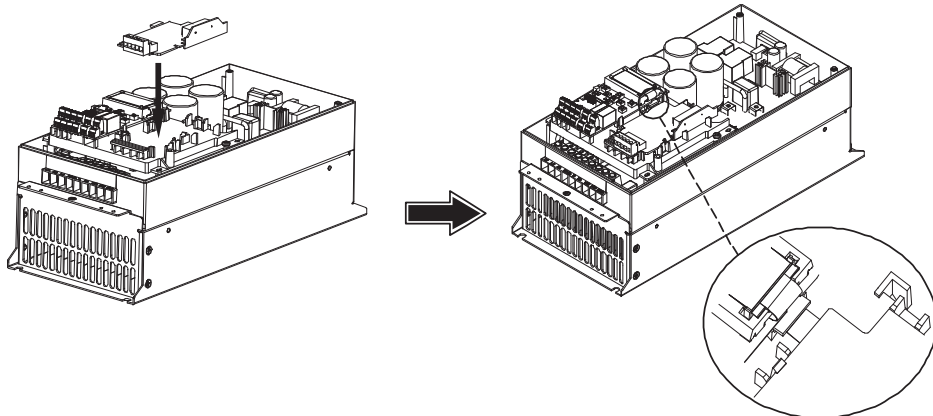

11566_00

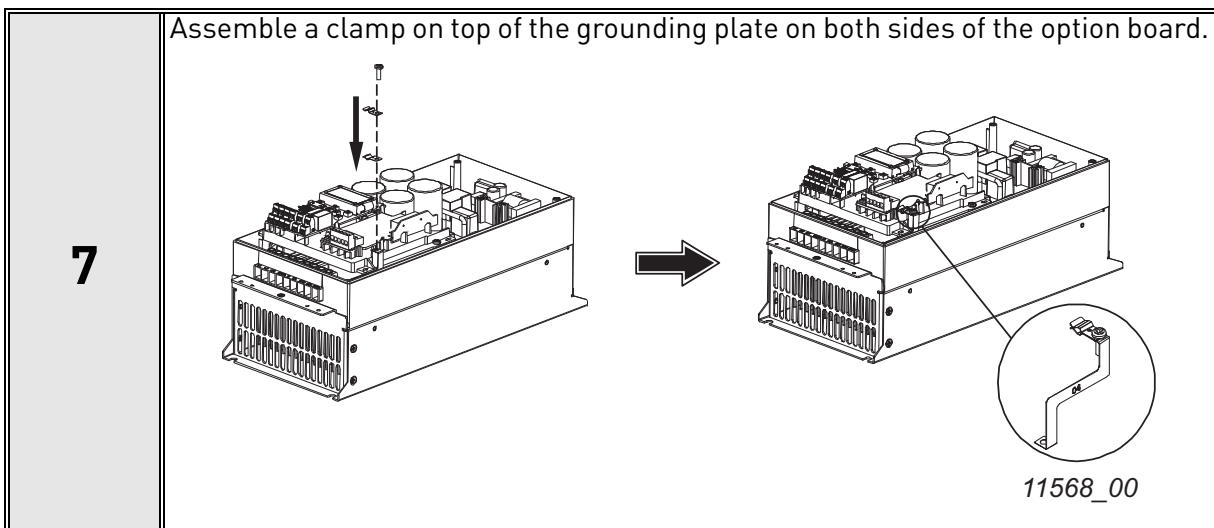
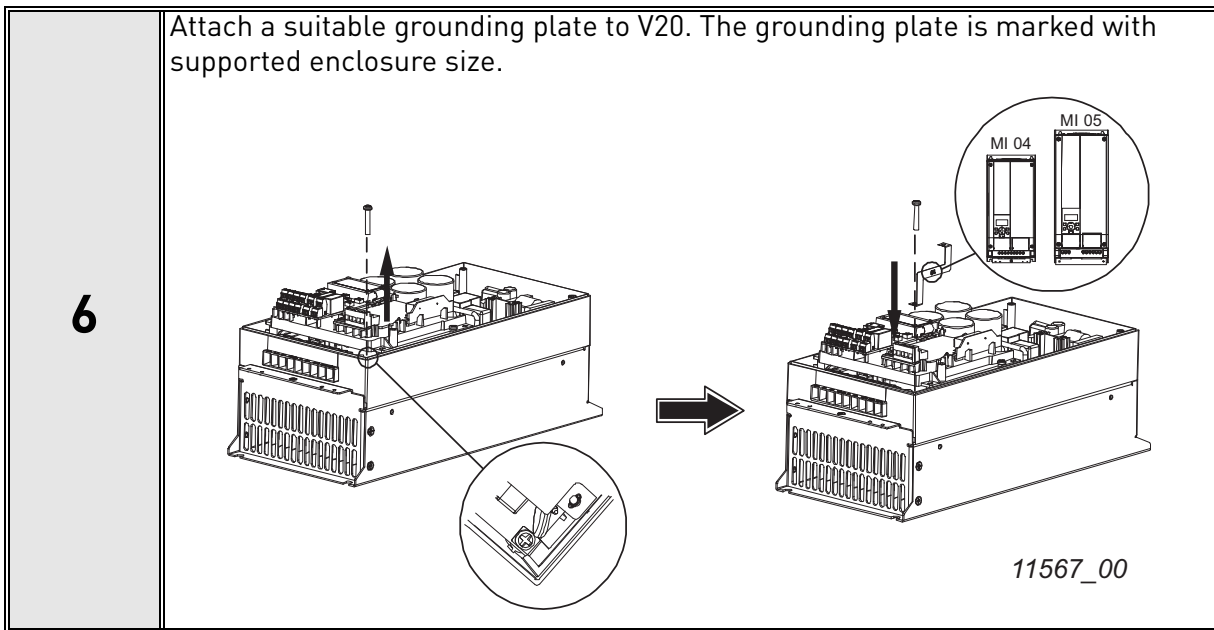

8

8a: For MI4: Close the cover.

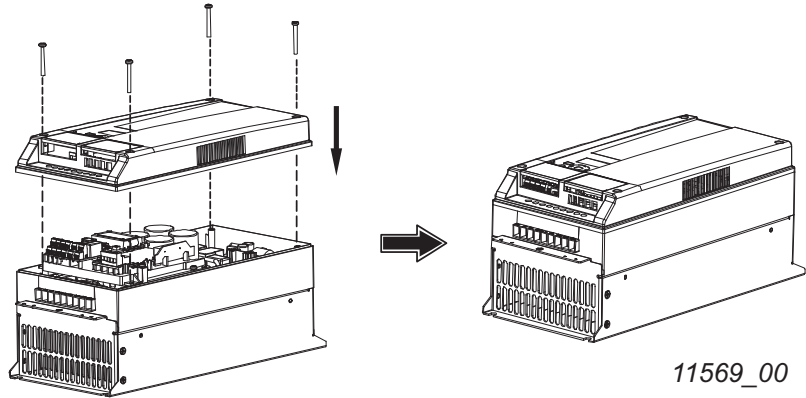

8b: For MI5: Remount the fan connector and close the cover.

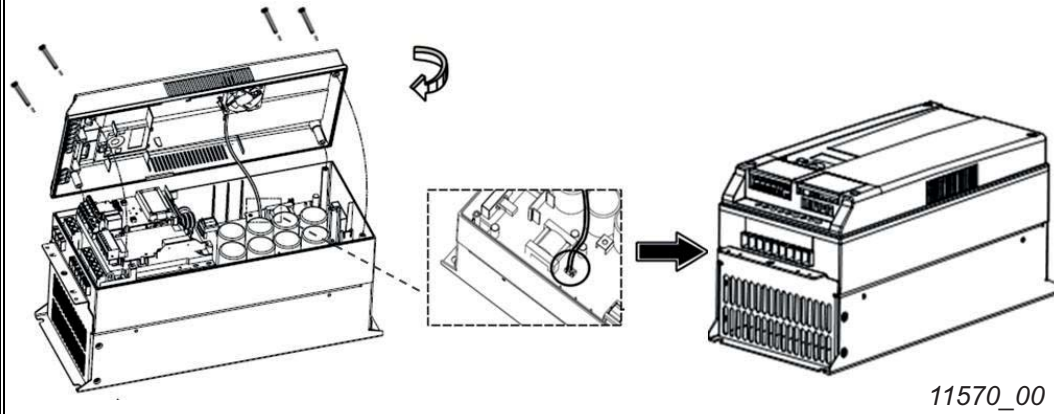

5.3 INSTALLATION IN VACON® 20 X AND 20 CP



Do not add or replace option boards or fieldbus boards on an AC drive with the power switched on. This may damage the boards.

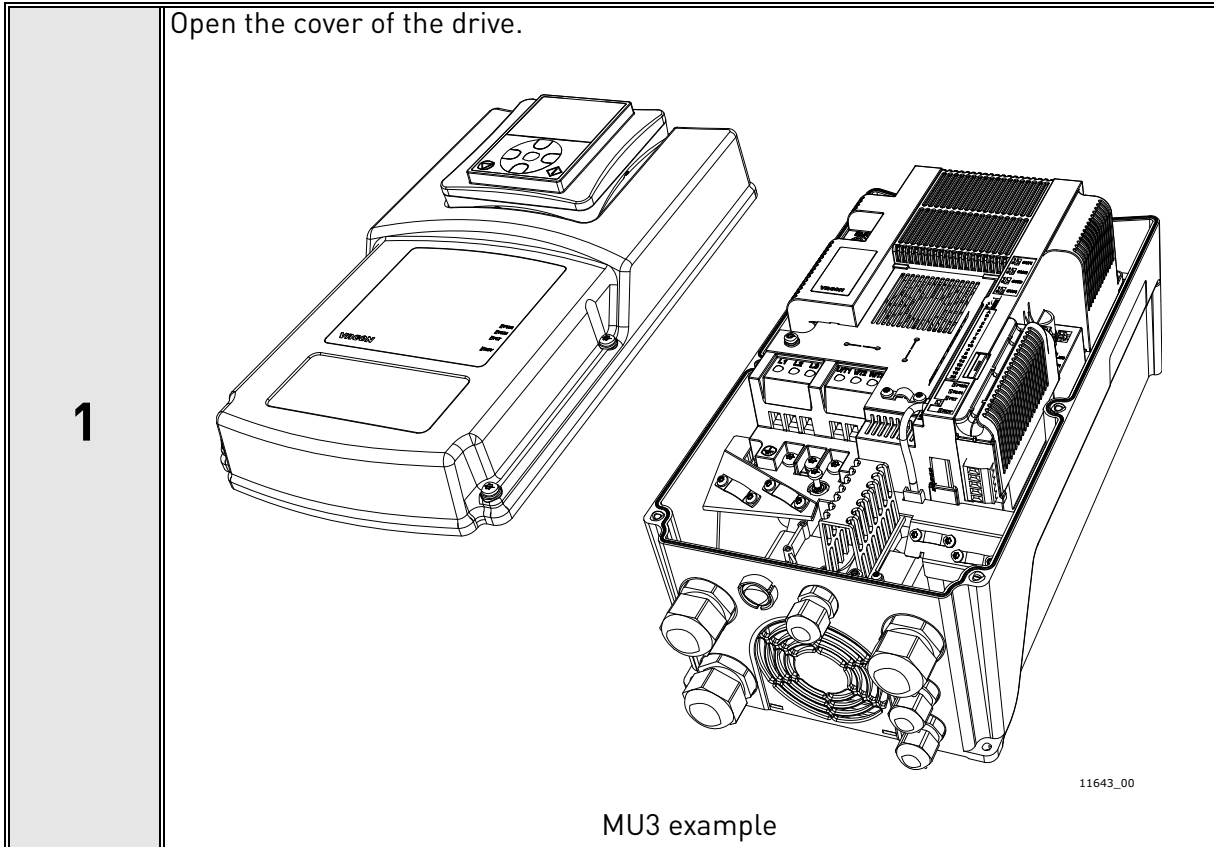

The relay outputs and other I/O-terminals may have a dangerous control voltage present even when the drive is disconnected from mains.

2

Remove the option slot cover.

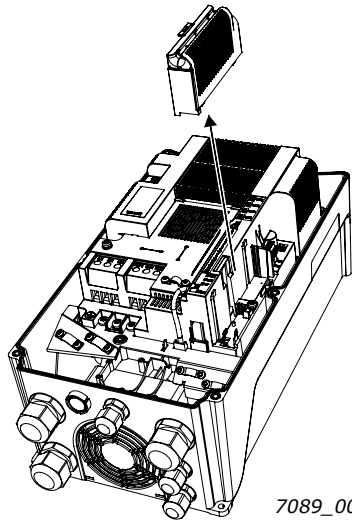

3

Install the option board into the slot as shown in the figure.

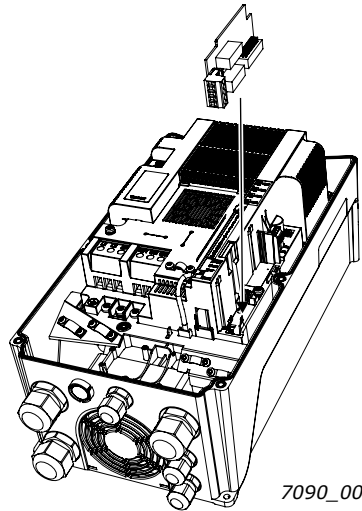

4

Mount the option slot cover. Remove the plastic opening for the option board terminals.

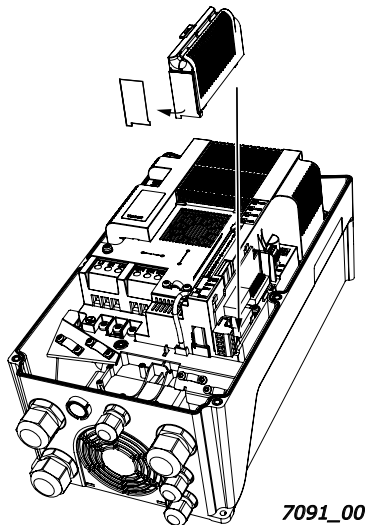

5.4 INSTALLATION IN VACON® 100 FAMILY

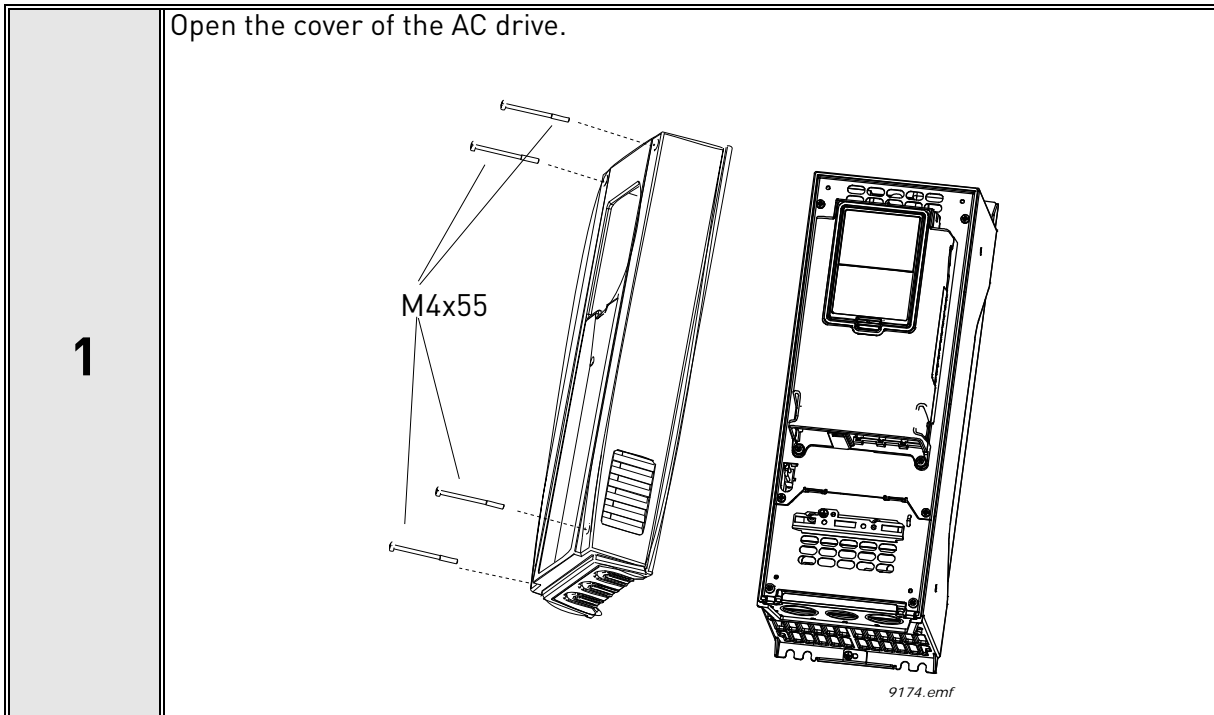

The relay outputs and other I/O-terminals may have a dangerous control voltage present even when VACON® 100 family AC drive is disconnected from mains.

2

Open the inner cover to reveal the option board slots (C,D,E).

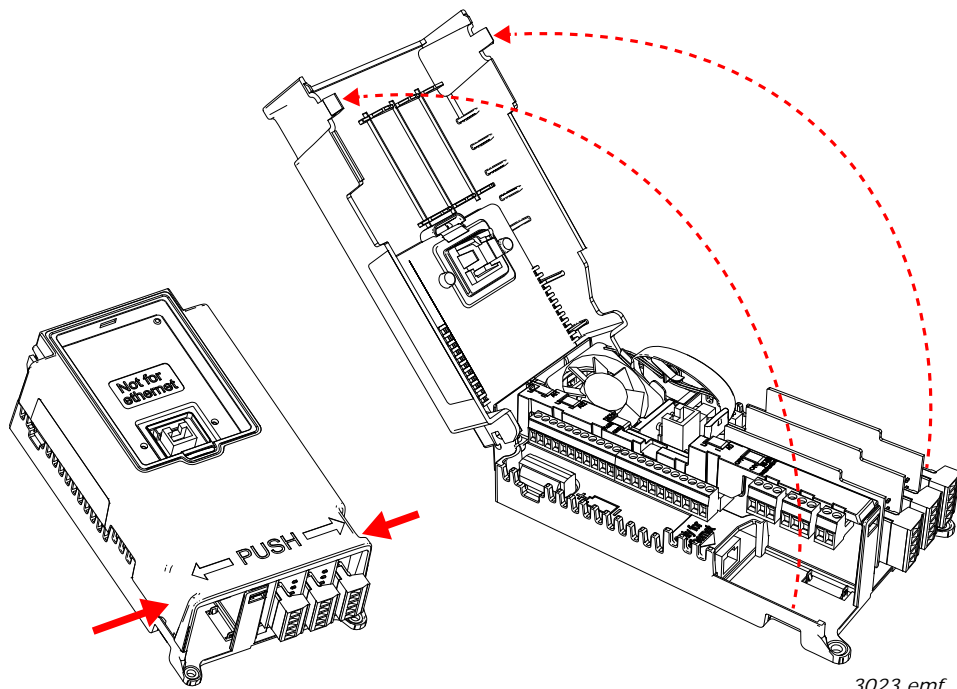

3023.emf

3

Install the fieldbus board into slot D or E.

NOTE: Incompatible boards cannot be installed on VACON® 100 family AC drive. Compatible boards have a slot coding that enable the placing of the board.

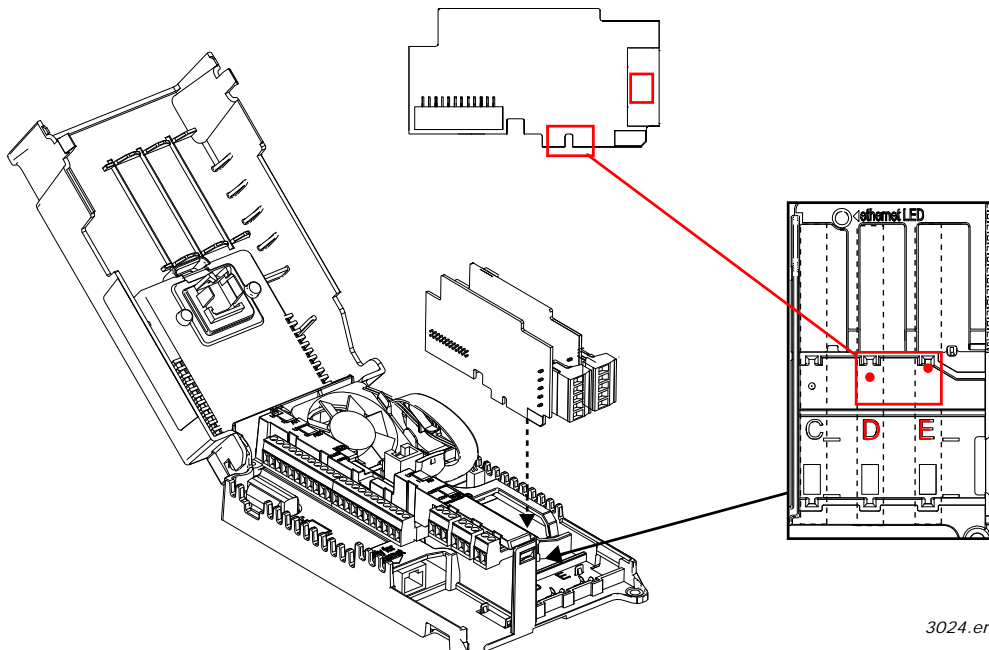

3024.emf

4

Then connect the cable to its appropriate OPTEC EtherCAT option board RJ-45 connector.

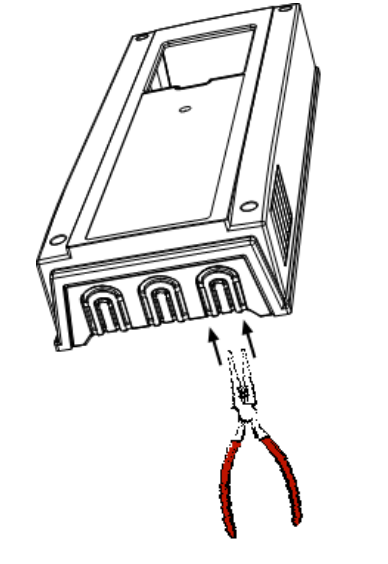
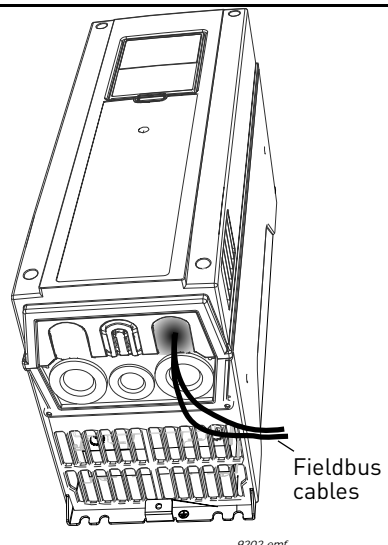
<p>5</p>	<p>Unless already done for the other control cables, cut free the opening on the AC drive cover for the fieldbus cable (protection class IP21). NOTE: Cut the opening on the same side you have installed the board in!</p>	
<p>6</p>	<p>Remount the AC drive cover and run the cable as shown in picture. NOTE: When planning the cable runs, remember to keep the distance between the fieldbus cable and the motor cable at a minimum of 30 cm. It is recommended to route the option board cables away from the power cables as shown in the picture.</p>	

5.5 INSTALLATION IN VACON® 100 X

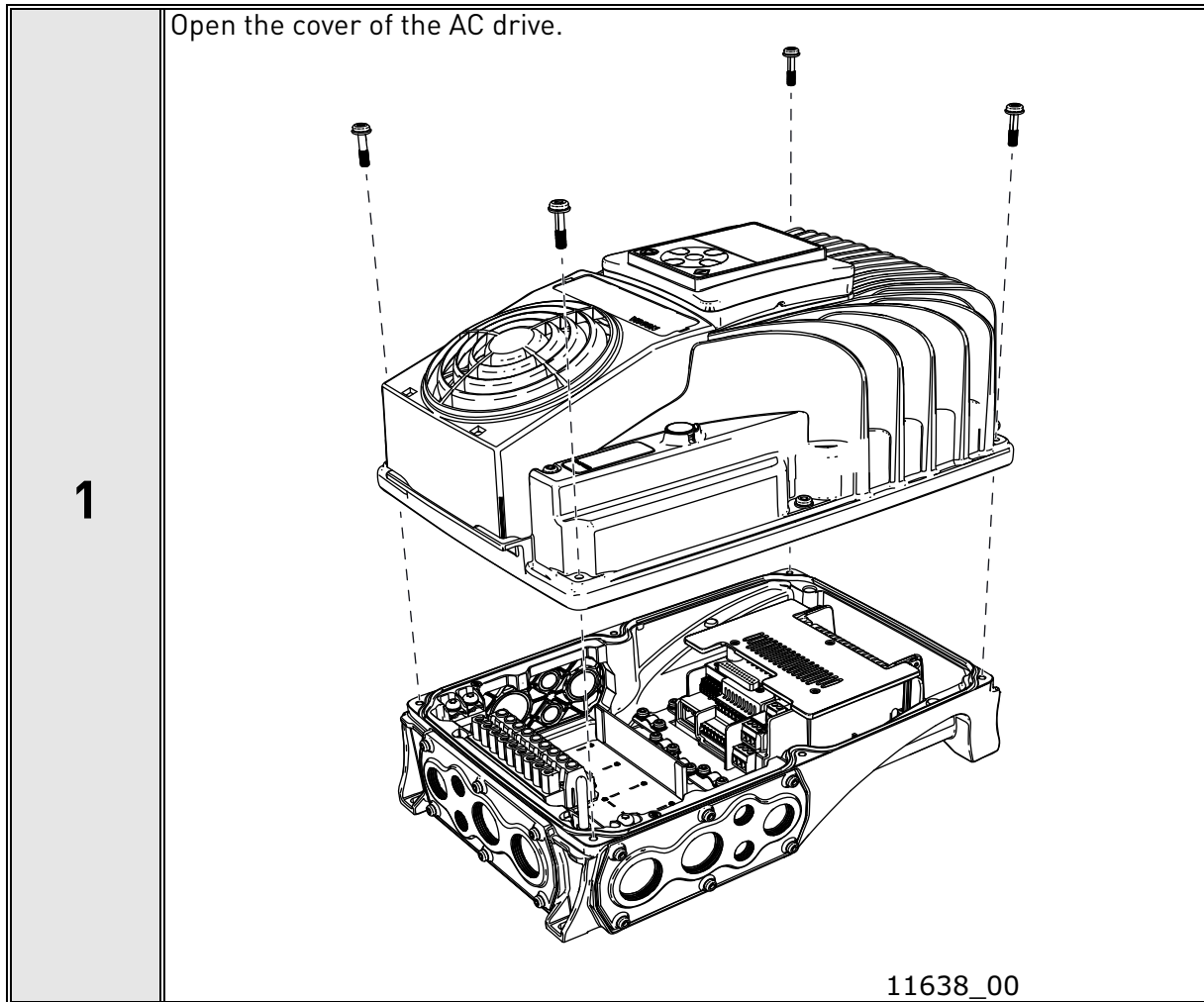

2

To get access to the option board slots, remove the screws and open the cover of the control unit.

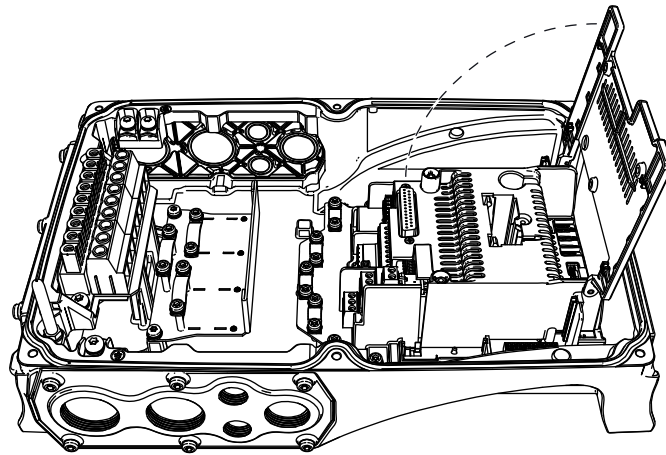
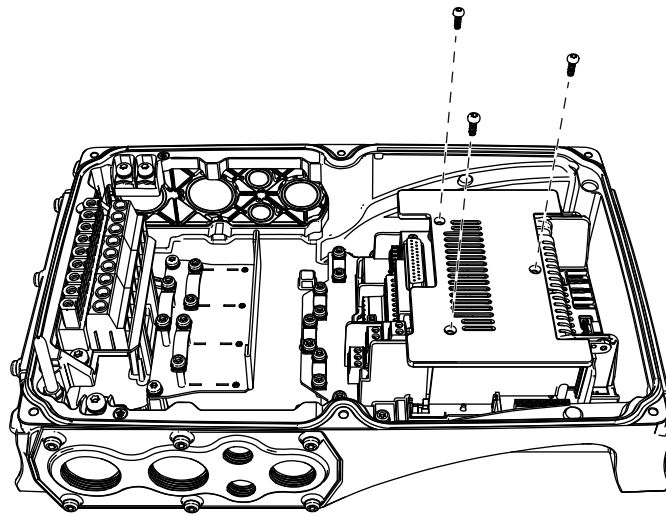

11639_00

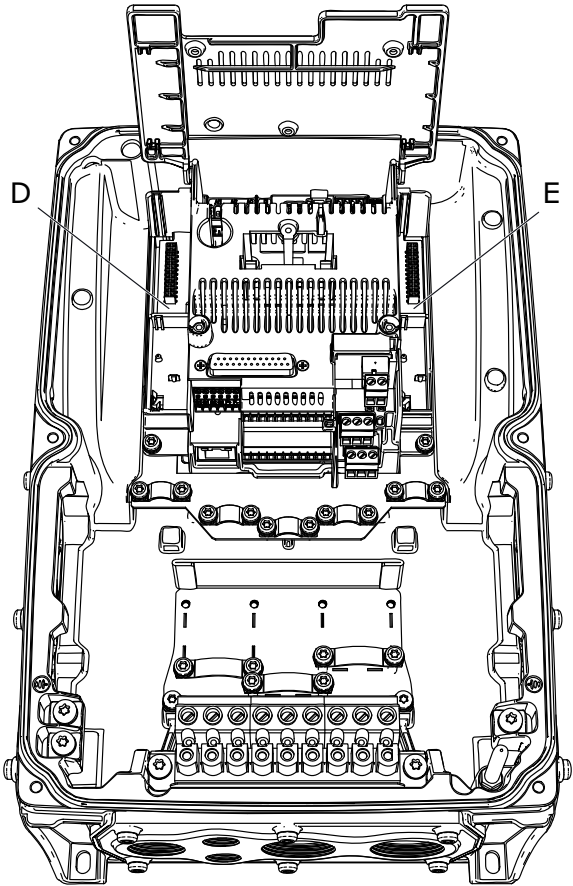
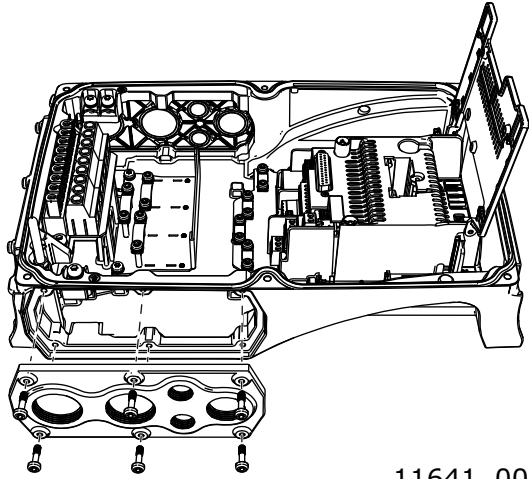
<p style="text-align: center; font-size: 24pt; font-weight: bold;">3</p>	<p>Install the option board into the correct slot, D or E.</p>  <p style="text-align: right;">11640_00</p>
<p style="text-align: center; font-size: 24pt; font-weight: bold;">4</p>	<p>Close the option board cover.</p>
<p style="text-align: center; font-size: 24pt; font-weight: bold;">5</p>	<p>Remove the cable entry plate. If you installed the option board in the slot D, use the cable entry plate on the right side. If you installed the option board in the slot E, use the cable entry plate on the left side.</p> <p>NOTE! The cable entry plate at the bottom of the drive is used only for mains and motor cables.</p>  <p style="text-align: right;">11641_00</p>
<p style="text-align: center; font-size: 24pt; font-weight: bold;">6</p>	<p>Open the necessary holes in the cable entry plate. Do not open the other holes. See the VACON® 100 X Installation Manual for the dimensions of the holes.</p>

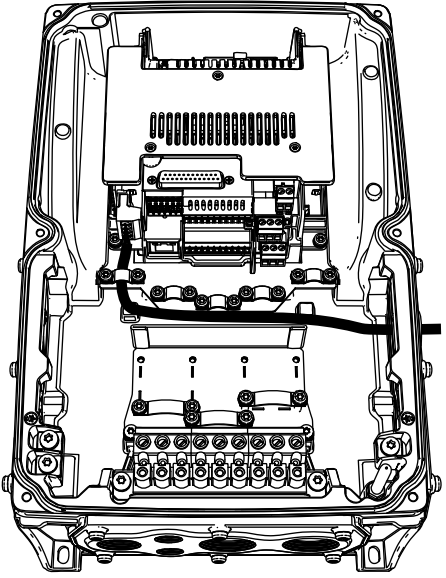
7	<p>Attach a cable gland on the hole in the cable entry plate. Pull the Ethernet cable through the hole.</p> <p>NOTE! The Ethernet cable must go through the correct cable entry plate to avoid going near the motor cable.</p>	 <p style="text-align: right;">11642_00</p>
8	Put the cable entry plate back.	
9	Close the cover of the AC drive.	

5.6 PC TOOLS

Before connecting the OPTE9 option board to the network, its IP addresses must be set according to the network. By default, the option board uses a DHCP server to get an IP address. If your network does not have a DHCP server, you need to set an IP address manually. This can be accomplished with the PC tools described in this chapter or with the AC drive's keypad (see Chapter 6).

For more information about IP addresses or a DHCP server, contact your network administrator.

5.6.1 PC TOOL SUPPORT

This table describes what PC tools are supported in each AC drive type. The connection type “serial” means a direct connection to the AC drive. The connection type “Ethernet” means a connection via the OPTE9 Ethernet port.

Table 10. The supported PC tools with different AC drives

Tool	VACON® 100 family		VACON® NXS/NXP		VACON® 20 family	
	Serial	Ethernet	Serial	Ethernet	Serial	Ethernet
VACON® Loader	x		x		x	
VACON® Live	x	x			x	
NCIPConfig		x		x		x
NCDrive				x		
NCLoad	Not supported with OPTE9 Dual Port Ethernet					

5.6.2 UPDATING THE OPTe9 OPTION BOARD FIRMWARE WITH VACON® LOADER

The VACON® Loader can be downloaded from <http://drives.danfoss.com> website. It has been bundled with the VACON® Live software package.

To update the option board firmware, follow the steps below.

NOTE! With VACON® 20, the baud rate 9600 must be used. With VACON® 20 X and VACON® 20 CP, the following baud rates are supported: 9600, 19200, 38400 or 57600.

Step 1. Connect your PC to the controller by using the USB/RS485 cable.

Then select the firmware file which you want to load to the option board and double click it. This will start the VACON® Loader software. You can also start the program from the Windows Start menu. In this case, select the firmware file using the "Browse"-button (see Figure 13).

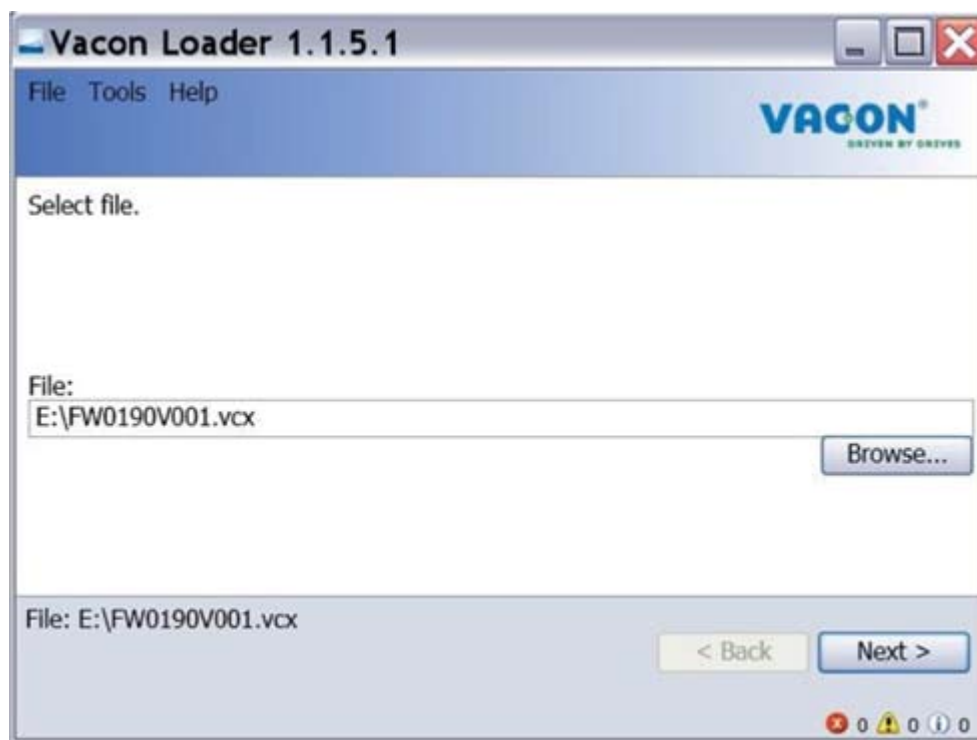

11598_00

Figure 13. VACON® Loader: File selection

Step 2. Press 'next' and wait for the loader to find the network drives.

Then select a drive from the list and press 'Connect to Selected'. See Figure 14.

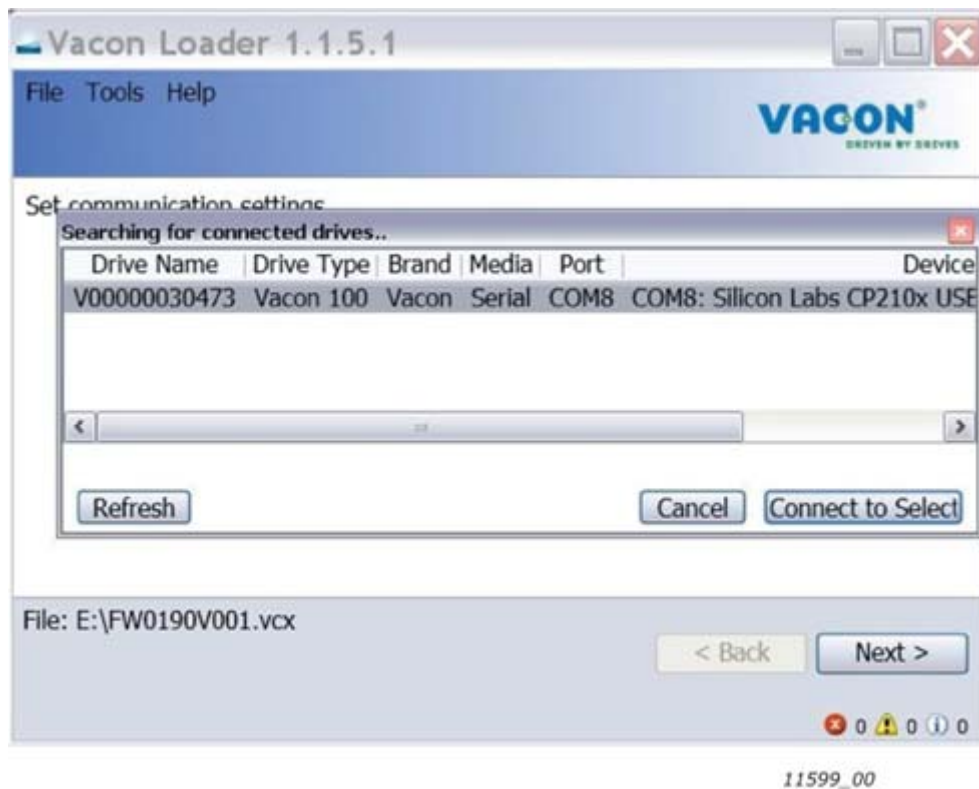

Figure 14. VACON® Loader: Connecting to drive

Step 3. Select the modules to be updated, press 'next' and wait until the operation is finished. See Figure 15 and Figure 16.



Figure 15. Option board slot selection

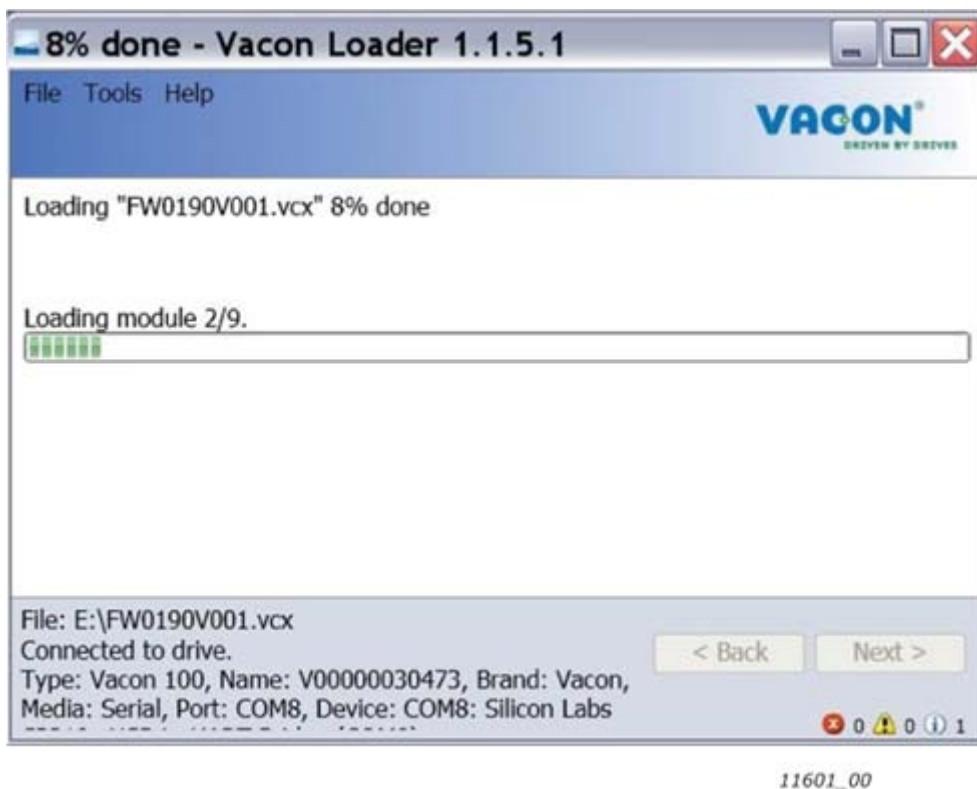

Figure 16. VACON® Loader: Firmware loading

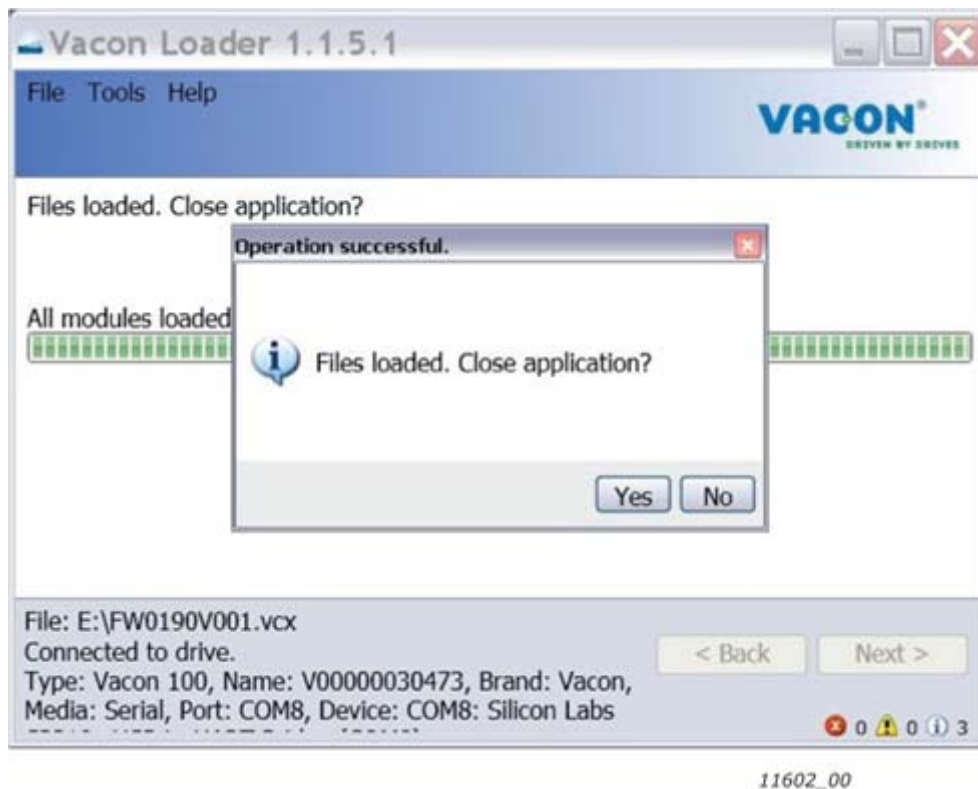

Figure 17. VACON® Loader: Loading is finished

5.6.3 PC TOOLS FOR VACON® NX / NCIPCONFIG

The VACON® OPTE9 Dual Port Ethernet option board can be configured with the NCIPConfig tool.

Before the option board can be used, a valid IP address must be set. By default, the OPTE9 uses a DHCP server. If your network does not have a DHCP server, you will need to set an IP address manually and change the "IP Mode" to "static".

For more information about IP addresses or a DHCP server, contact your network administrator.

To install the NCIPConfig tool, start the installation program from the CD or download it from <http://drives.danfoss.com> website. After starting the installation program, follow the on-screen instructions.

Once the program is installed successfully, you can launch it by selecting it in the Windows Start menu. Follow these instructions to set the IP addresses. Select **Help --> Manual** if you want more information about the software features.

Step 1. Connect your PC to the Ethernet network with an Ethernet cable.

You can also connect the PC directly to the device using a crossover cable. This option may be needed if your PC does not support the Automatic crossover function.

Step 2. Perform network nodes scanning.

Select **Configuration --> Scan** (Figure 18) and wait until the devices connected to the bus in the tree structure are displayed on the left side of the screen.

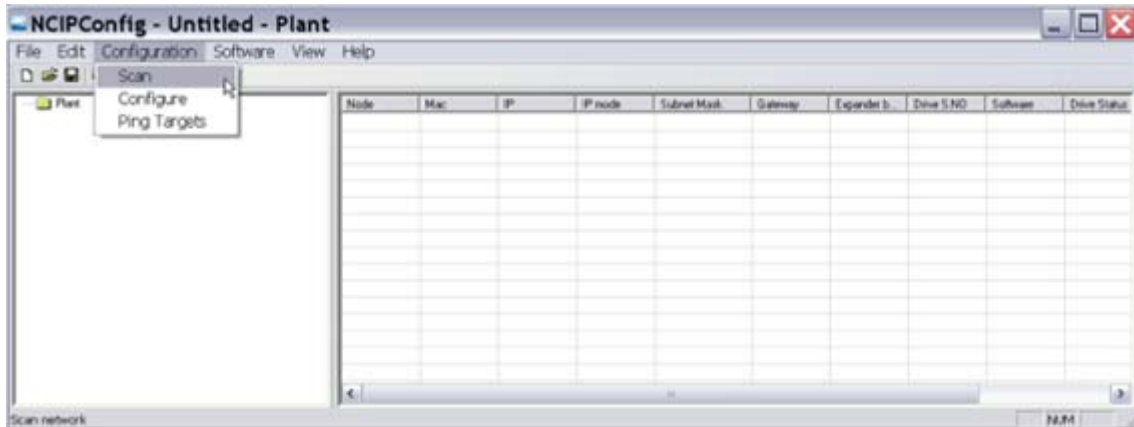

11629_00

Figure 18. Network nodes scanning

NOTE! The NCIPConfig uses broadcast messages for scanning devices. Some network switches might block the broadcast messages. In this case, each network node must be scanned separately.

Step 3. Set the option board settings.

To change the board name, select the cell in the column 'Node' and enter the name of the node. Notice that this changes the name seen only in VACON® PC tools. PROFINET IO Name Of Station value must be changed via protocol settings or over PROFINET IO DCP protocol.

To change the node IP settings, select the cell in the right column and enter the value according to the network IP settings. The program will report conflicts with a red color in table cells.

To change the IP Mode, click the cell and select the desired mode from the dropdown list (Figure 19).

To commit the changes, mark the checkbox and select **Configuration->Configure-** from the menu.

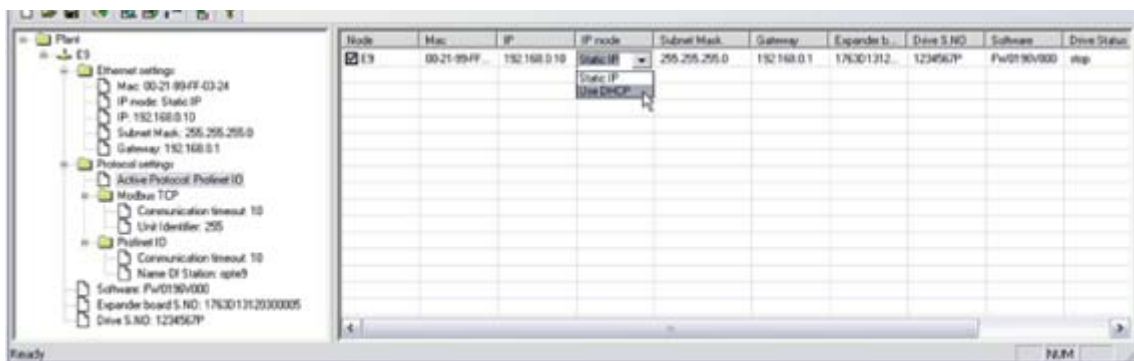

11630_00

Figure 19. Change the option board settings

Step 4. Change the protocol settings.

To change the currently active protocol, select the setting from the tree structure. A dialog box opens. Select the desired protocol from the dropdown list (Figure 20). After clicking "ok" the setting will be activated.

The rest of the settings can be changed similarly, but values are edited in the tree (Figure 21). See Chapter 6 for more information about the settings.

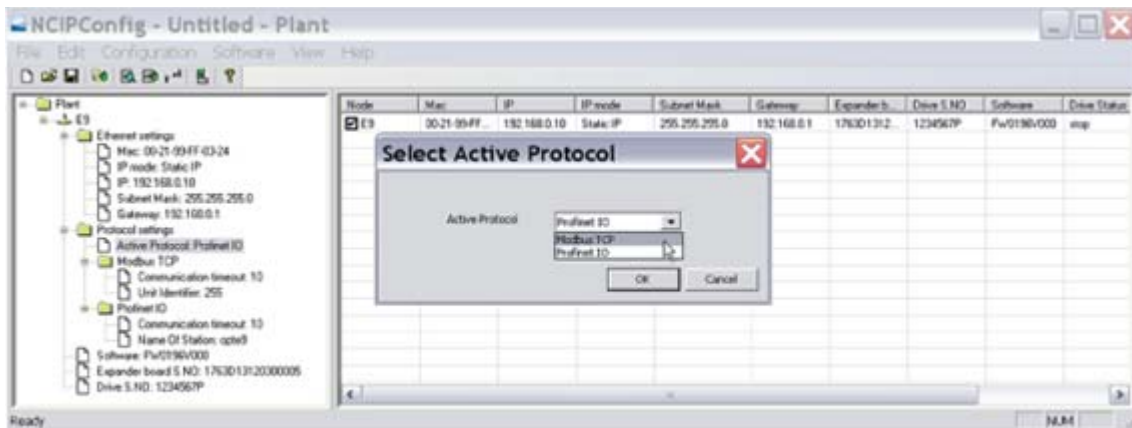

11631_00

Figure 20. Change the currently active protocol value

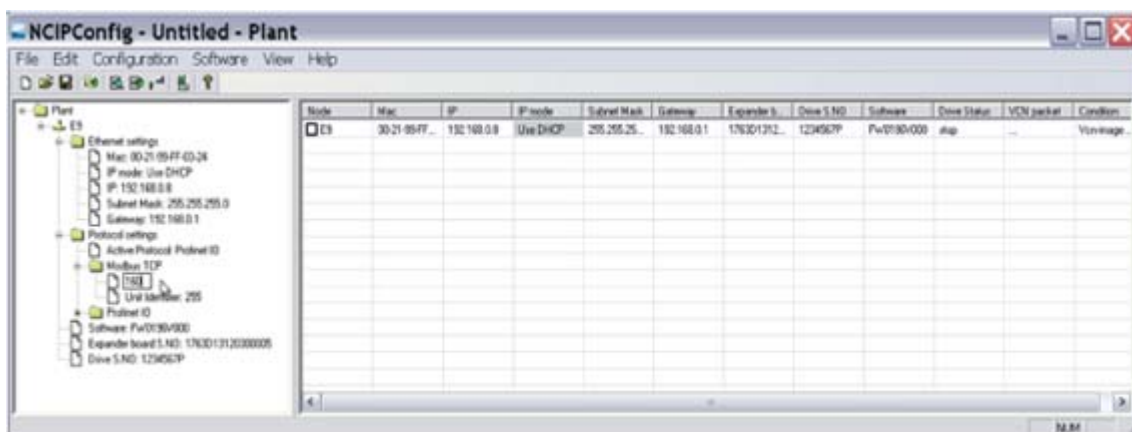

11632_00

Figure 21. Change the communication timeout value

5.6.4 PC TOOLS FOR VACON® NX / NCDRIVE

You can configure the drive parameters with the NCDrive. Some of the OPTE9 parameters can be configured with the NCDrive. However, it is recommended to use the NCIPConfig tool for the OPTE9 Dual Port Ethernet configuration in the VACON® NX S/P AC drives.

You need to have a PC with an Ethernet connection and the NCDrive tool installed. To install the NCDrive, start the installation program from the CD or download it from <http://drives.danfoss.com> website. After starting the installation program, follow the on-screen instructions.

Once the program is installed successfully, you can launch it by selecting it in the Windows Start menu. Select **Help --> Contents** if you want more information about the software features.

Before using the NCDrive, you need to configure the option board IP settings with NCIPConfig. If the option board does not have valid IP settings you will not be able to connect with the NCDrive.

Step 1. Connect your PC to the Ethernet network with an Ethernet cable.

You can also connect the PC directly to the device using a crossover cable. This option may be needed if your PC does not support Automatic crossover function.

Step 2. In order to connect to the drive, you need to select the active drive first. Press the "Drive Select" button (see Figure 22) to scan the network drives.

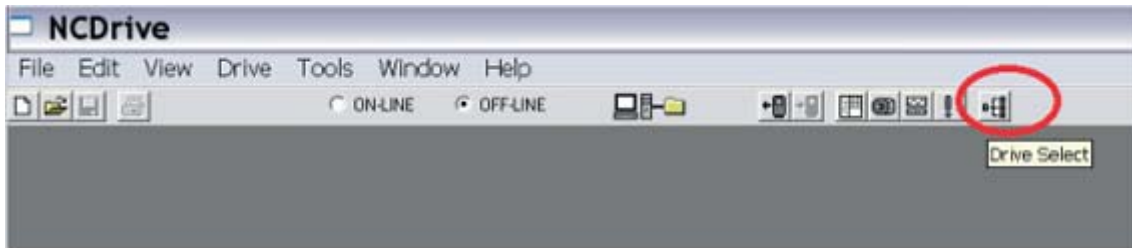

11603_00

Figure 22. NC Drive: "Drive Select"

Step 3. In the "Select the active drive" dialog (see Figure 23), select the drive you want to connect to. Then press the "Set Active Drive" button. Now you can close the dialog.

The IP information presented in the dialog comes from the option board, other information comes from the drive.

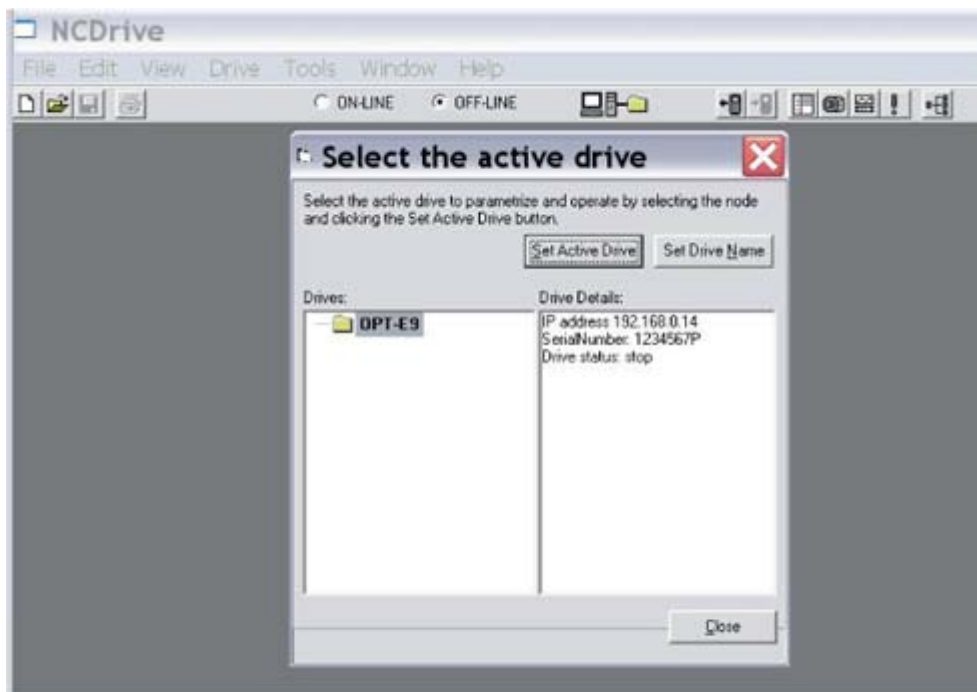

11604_00

Figure 23. NC Drive: Active drive selection

Step 4. Press the "ON-LINE" button. The NCDrive will connect to the drive and start loading parameter information. This will take a few minutes. See Figure 24 and Figure 25.

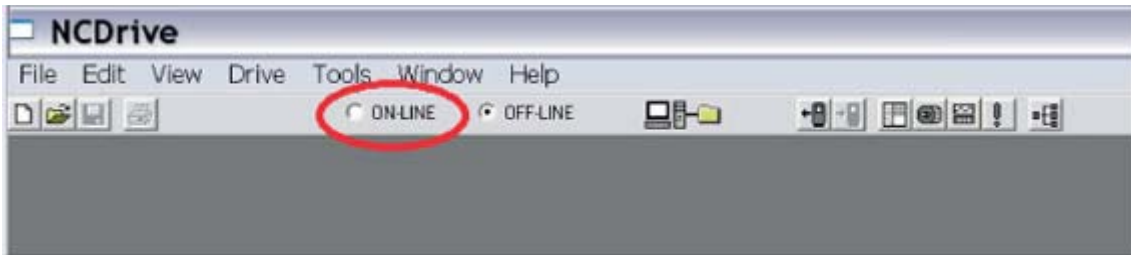

11605_00

Figure 24. NC Drive: Going online

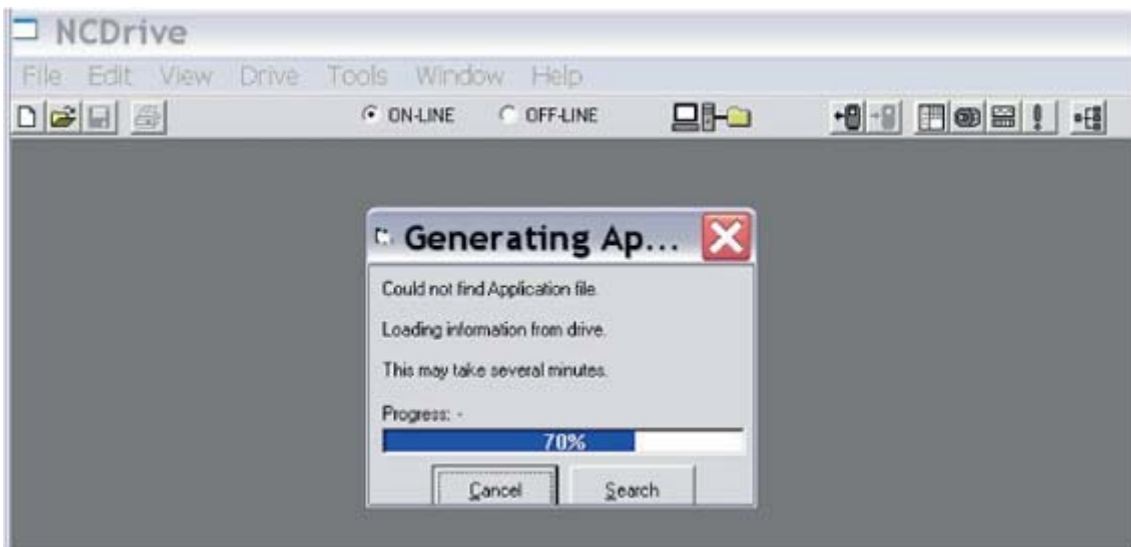

11606_00

Figure 25. Loading information from the drive

Step 5. To change the option board settings, navigate to the "M7Expander boards" menu and select the slot that the OPTE9 is connected to. You can change the IP address, network mask and default gate address in the menu item "G 7.x". After you have changed the IP settings, you need to change "IP Mode" to "Fixed IP" in order to activate the settings.

For more information about these settings, see Chapter 6.1.

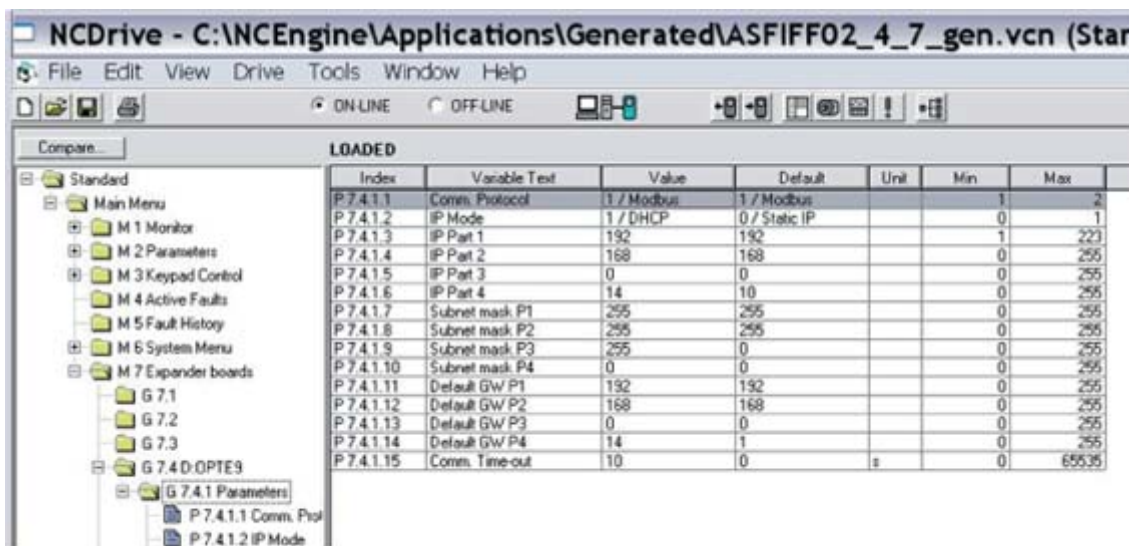

11607_00

Figure 26. NC Drive: OPTE9 parameters

NOTE! The NCDrive software can be used with the Ethernet board in VACON® NXS and NXP drives.

NOTE! The NCDrive software is recommended to be used in LAN (Local Area Network) only.

NOTE! This feature does not work with VACON® 100 family AC drives.

5.6.5 PC TOOLS FOR VACON® 100 FAMILY AND VACON® 20 / VACON® LIVE

VACON® Live can be used to configure the IP settings of the OPTE9 option board. VACON® Live can be downloaded from <http://drives.danfoss.com> website.

To configure the IP settings of the OPTE9 option board, follow the steps below:

NOTE! VACON® 20, VACON® 20 X and VACON® 20 Cold Plate do not support VACON® Live connection over the OPTE9 Ethernet port.

Step 1. Connect your PC to the Ethernet network with an Ethernet cable. You can also connect the PC directly to the drive using a crossover cable. This option may be needed if your PC does not support Automatic crossover function.

You can also connect to the VACON® 100 family AC drive by its serial port. In any case the steps below are the same for both connections.

NOTE! You cannot use VACON® Live via the option board if the option board does not have a valid IP address. If you change the IP settings of the option board when connected through it, VACON® Live connection will be lost.

Step 2. Start VACON® Live. When the program starts and it asks "Select startup mode", select "Online". The program will scan your network for compatible drives. When found, they will be added to the list. Select the drive that the OPTE9 option board is connected to and press "Connect to select".

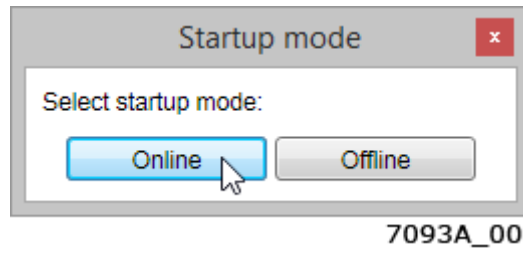

7093A_00

Figure 27. VACON® Live: The "Startup mode" dialogue box



7094A_00

Figure 28. VACON® Live: The "Select devices" dialogue box

NOTE! The first column is the drive's name, but the information about IP and MAC addresses come from the option board (if the device on the list is an option board).

NOTE! Some switches block broadcast messages. In this case, each network node must be scanned separately.

Step 3. To change the IP settings, navigate to the "5. I/O and Hardware" menu and select the slot that the OPTE9 is connected to. You can change the IP address, network mask and default gate address in the menu item "5.x.3 Parameters". After you have changed the IP settings, you need to change "IP Mode" to "Fixed IP" in order to activate the settings. For more information about these settings, see Chapter 6.1.

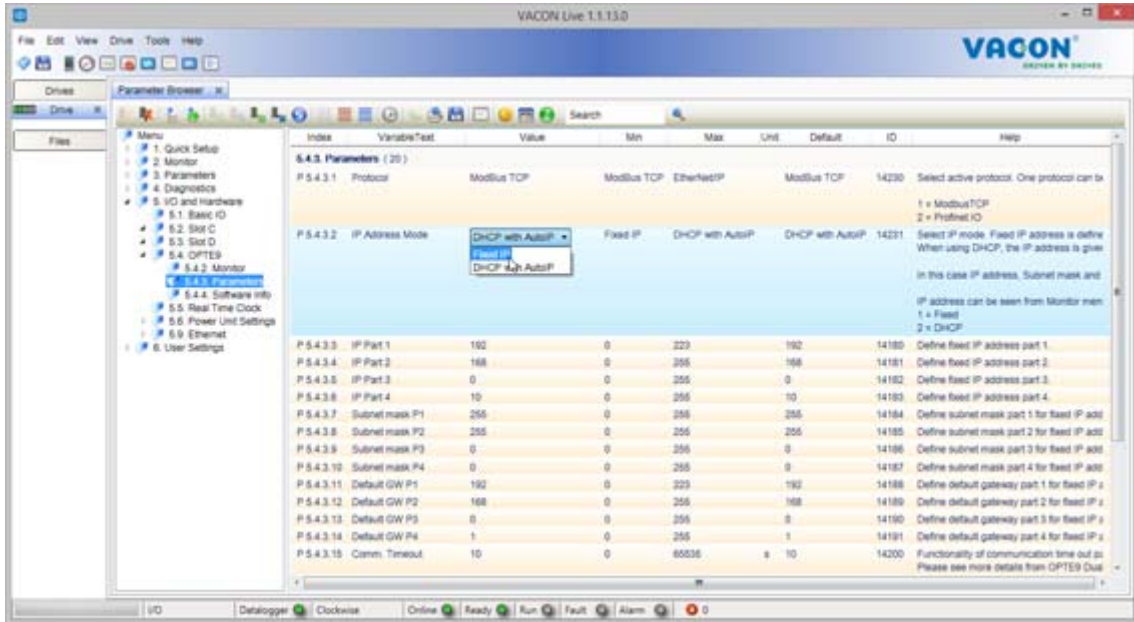

11715_00

Figure 29. VACON® Live: OPTE9 IP Address Mode

6. COMMISSIONING

The VACON® OPTE9 Dual Port Ethernet option board is commissioned with the control keypad by giving values to appropriate parameters in the option board menu (or via PC tools, see Chapter 5.6 "PC Tools").

Keypad commissioning procedures and location of parameters differ a little with different AC drive types:

- In the VACON® NXP/NXS option board, parameters are located under the menu M5 (Expander board menu).
- In the VACON® 100 family option board, parameters are located under the menu M7 (I/O and Hardware).

6.1 OPTION BOARD MENU

The control keypad makes it possible for the user to see which expander boards are connected to the control board and to reach and edit the parameters associated with the expander board.

6.1.1 OPTION BOARD PARAMETERS

The OPTE9 board parameters are listed in the table below.

Table 11. Parameters menu structure

#	Name	Default	Range	Description
1	Comm. Protocol*	Modbus	Modbus (1), Profinet IO (2), EtherNet/IP (3)	Active protocol
2	IP Mode*	DHCP	Fixed IP (1), DHCP (2)	IP mode. When in DHCP mode, the IP address cannot be changed manually.
3	IP Part 1*	192	1...223	IP Address Part 1
4	IP Part 2*	168	0...255	IP Address Part 2
5	IP Part 3*	0	0...255	IP Address Part 3
6	IP Part 4*	10	0...255	IP Address Part 4
7	Subnet mask P1	255	0...255	Subnet Mask Part 1
8	Subnet mask P2	255	0...255	Subnet Mask Part 2
9	Subnet mask P3	255	0...255	Subnet Mask Part 3
10	Subnet mask P4	255	0...255	Subnet Mask Part 4
11	Default GW P1	192	0...255	Default Gateway Part 1
12	Default GW P2	168	0...255	Default Gateway Part 2
13	Default GW P3	0	0...255	Default Gateway Part 3
14	Default GW P4	1	0...255	Default Gateway Part 4
15	Comm. Timeout	10 s	0...65535 s	Communication timeout in seconds
16	PNIO Name Of Station	""	1...240 char	For Profinet IO only. Only visible in VACON® 100 family AC drives.

#	Name	Default	Range	Description
17	EIP Output Instance*	21	"20" (1), "21" (2), "23" (3), "25" (4), "101" (5), "111" (6), "128" (7), "131" (8), "151" (9), "161" (10)	EtherNet/IP output assembly instance. Shows the active output instance. The instance is selected during the IO connection open request.
18	EIP Input Instance*	71	"70" (1), "71" (2), "73" (3), "75" (4), "107" (5), "117" (6), "127" (7), "137" (8), "157" (9), "167" (10)	EtherNet/IP input assembly instance. Shows the active input instance. The instance is selected during the IO connection open request.
19	EIP Product Code Offset	0	0...99	
20	Mode*	Normal	Normal (1), NX Mode (2), V100 Mode (3)	Only in VACON® 100 family. After this setting is changed, drive must be restarted.
21	Modbus Unit Identifier*	255	1...247, 255	Modbus Unit Identifier. Used only with Modbus UDP.

* These parameters are locked when either PROFINET IO connection, EtherNet/IP implicit connection or a Modbus connection is established to write process data (i.e. when fieldbus can be used to control the process).

6.1.2 OPTION BOARD MONITORING VALUES

The monitor menu shows the currently active IP settings. For example, these values will show '0' when a DHCP server is trying to get an IP address. After the address is received, these values are updated.

Table 12. Monitor menu structure

#	Name	Range	Description
1	IP Part 1	1...223	Current IP Address Part 1
2	IP Part 2	0...255	Current IP Address Part 2
3	IP Part 3	0...255	Current IP Address Part 3
4	IP Part 2	0...255	Current IP Address Part 4
5	Subnet mask P1	0...255	Current Subnet Mask Part 1
6	Subnet mask P2	0...255	Current Subnet Mask Part 2
7	Subnet mask P3	0...255	Current Subnet Mask Part 3
8	Subnet mask P4	0...255	Current Subnet Mask Part 4
9	Default GW P1	0...223	Current Default Gateway Part 1
10	Default GW P2	0...255	Current Default Gateway Part 2
11	Default GW P1	0...255	Current Default Gateway Part 3
12	Default GW P4	0...255	Current Default Gateway Part 4
13	Fieldbus protocol status	Initializing (1), Stopped (2), Operational (3), Faulted (4)	When device has started, it will stay in "Initializing" state until the connection has been opened to the device. At that point, the status will change to "operational". If the connection is closed or lost, the state will change to "Stopped" or "Faulted".
14	Communication status	0.0...64.999	0-64 Number of messages with errors 0-999 Number of messages without communication errors
15	Drive control word	-	Control word in drive format
16	Drive status word	-	Status word in drive format
17	Protocol control word	-	Control word in protocol format
18	Protocol status word	-	Status word in protocol format
19	EIP Product Code	-	Currently used EtherNet/IP Product Code
20	MAC Address	-	Used device MAC address. Available in VACON® NXP, NXS and VACON® 100 family AC drives.

6.1.3 COMMUNICATION PROTOCOL

The OPTE9 option board comes with several fieldbus protocols. The user can select the one used in their network from the list. Only one protocol can be active at a time.

6.1.4 IP MODE

The IP mode determines how the option board IP settings are set. If a DHCP server is selected, then the option board will try to retrieve its IP settings from the DHCP server connected to the local network. If the option board is unable to retrieve its IP settings, it will set a link-local address as the current IP address after about one minute (for example 169.x.x.x).

If "Fixed IP" is set as IP mode, the settings IP Part 1-4, Subnet Part 1-4 and Default gateway 1-4 are used.

6.1.5 IP ADDRESS

IP is divided into 4 parts. (Part = Octet). Changing these values does not have any effect if the current IP mode is "DHCP". The value will become active when the mode is changed to "fixed IP". When these values are changed and the mode is "fixed IP", the changes are taken into use immediately.

The monitoring values will always show the currently used IP settings. If the mode is "fixed IP", they will show the same values as the IP parameters. If the mode is "DHCP", they will show 0.0.0.0 when the OPTE9 is getting the IP settings from the DHCP server. When the IP settings are received from the DHCP server, they will be shown in the monitoring values. The IP parameters will continue to display the fixed values. If no IP parameters are received from the DHCP server, the option board will use link-local generated values (for example 169.x.x.x) which are again shown only in the monitoring values.

The PROFINET IO DCP protocol can be used to set temporary IP settings. This means that after the device is restarted, the option board does not have IP settings. The PLC then must set the IP address again before starting the communication. Temporary IP settings are indicated with zero value. When the IP settings are temporary, the parameters "IP address", "subnet mask" and "gateway" are set to 0.0.0.0 (and the IP mode is "fixed IP"). The monitoring values will always show the currently used IP settings.

The table below gives an example of the option board panel parameters with the temporary IP settings.

Table 13.

Temporary value		Parameter	Monitoring value
IP Address	192.168.0.10	0.0.0.0	192.168.0.10
Subnet mask	255.255.255.0	0.0.0.0	255.255.255.0
Gateway	192.168.0.1	0.0.0.0	192.168.0.1

When the device has been restarted, the monitoring values will also show 0.0.0.0.

6.1.6 COMMUNICATION TIMEOUT

It defines how much time can pass from the last received message from the Master Device before a fieldbus fault is generated. The functionality of this value is protocol-specific.

A fieldbus fault is also generated if the Ethernet link is down for over 60 seconds after the device startup. The Ethernet link status is being checked until the fieldbus communication is activated. After that the active fieldbus protocol controls the activation of the fieldbus fault.

The functionality of this value is protocol-specific.

6.1.6.1 Modbus

For Modbus, this value defines a time in which a message must be received (from Client in Modbus TCP/UDP) before a fieldbus fault is generated. If timeout is set to zero, no fault is created.

See Chapter 7.4.

6.1.6.2 Profinet IO and EtherNet/IP

For these protocols, this value is considered as an additional timeout which works on top the timeout mechanism of the protocol. When a connection loss is noticed, a fault activation is started. If communication timeout value is zero, the fault is activated immediately, otherwise the fault activates after a specified time. If the connection is reopened before the specified time has elapsed, no fault is created.

See Chapter 8.5 "PROFINET IO communications and connection timeout" for more details on how a timeout is created in OPTE9 while using PROFINET IO protocol.

See Chapter 9.1.6 "EtherNet/IP communication and connection timeout" for more details for more details on how a timeout is created in OPTE9 while using EtherNet/IP protocol.

6.1.7 **PROFINET IO - NAME OF STATION**

The Profinet IO "Name of Station" parameter can be set via VACON[®] Live or NCIPConfig. Other possibility is to set this name by writing it via Ethernet with the DCP protocol. In case of VACON[®] 100 family AC drives, the last 18 characters of the Name of Station can be read but not written from the panel. The name is empty if no name is set, or if name is set as "temporary" by network device.

NOTE! In case of VACON[®] 20, VACON[®] 20 X and VACON[®] 20 CP, the "Name of Station" must be defined with NCIPConfig tool or by writing the name from the PLC.

6.1.8 **EIP INPUT AND OUTPUT INSTANCE**

These parameters will show what instances are being used now. The instances actually used are taken from the IO connection open request. So, although these values are parameters they act more like monitoring values.

6.1.9 **EIP PRODUCT CODE OFFSET**

This value can be used to differentiate drives for the PLC program. For example, if one drive is running a different application (with different parameters) than other drives, this offset in the product code will enable the PLC to use a different EDS file to read those parameters from this drive.

Remember that if you change this value, you need also to change the EDS file used or change the product code value in your EDS file.

6.1.10 **MODE**

The "Mode"-parameter is available only when the OPTE9 has been installed to the VACON[®] 100 family AC drive. When the mode is changed, the OPTE9 fieldbus protocols will emulate old C-series option boards or VACON[®] 100 family internal implementations. Restart the AC drive after you have changed this value.

6.1.10.1 Modbus

Currently this mode has no effect on Modbus functionality

6.1.10.2 EtherNet/IP

NX Mode

- The PLC must use OPTCQ EDS instead of OPTE9.
- The AC/DC Drive Object: Parameter "Drive" mode will always return the actual drive mode. In "normal" mode "process drive" mode value is returned when the instance number is 25.
- The Drive identifier text will be "Vacon OPT-CQ" instead of being based on the drive where the option board is installed (for example: "Vacon 100 INDUSTRIAL").
- The Product code will be "2" instead of being based on the drive where the option board is installed.
- The Revision number (major, minor) will be 3.5 instead of OPTE9 revision number.
- The Connection instance will be "1" instead of "103" which is used by OPTE9 and VACON® 100 family AC drive.
- The Motor Data Object: "Rated Current" attribute will return the value in units of 10 milliamperes (1.9A => 190). In Normal mode, the value unit is 100 milliamperes (1.9A => 19). The same conversion is expected when setting the attribute value.
- The Motor Data Object: "Rated Frequency" attribute will return value with two decimals (50.00Hz => 5000). In normal mode, the value has no decimals (50.00Hz => 50Hz). The same conversion is expected when setting the attribute value.

Vacon 100 Mode

- The PLC must use Vacon 100 EDS instead of OPTE9
- The Drive identifier text will be "Vacon 100" instead of being based on the drive where the option board is installed (for example: "Vacon 100 INDUSTRIAL").
- The Product code will be "100" instead of being based on the drive where the option board is installed.
- The Revision number (major, minor) will be 2.1 instead of OPTE9 revision number.

6.1.10.3 PROFINET IO

NX Mode

- The PLC must use OPTCP GSDML instead of OPTE9.
- The Device id will be "1" instead of OPTE9's "2"
- The Vendor id will be "0x9500" instead of OPTE9's "0x01BA"
- The Device type text will be "OPTCP" instead of "OPTE9"
- The Telegrams will use FBSpeedReference/FBSpeedActual types instead of NSOLL_A / NIST_A.
- The Parameter channel used with Simatic PDM will not work in NX Mode.

Vacon 100 Mode

- The PLC must use VACON® 100 family GSDML instead of OPTE9.
- The Device id will be "1" instead of OPTE9's "2"
- The Device type text will be "VACON100" instead of "OPTE9"

6.1.11 **MAC ADDRESS**

This value shows the OPTE9 device MAC address. The format differs between used VACON® AC drive. In VACON® 100 family AC drives, the format is 00:11:22:33:44:55, and in VACON® NXS and NXP, the value is 001122334455. This value is not visible in VACON® 20 family AC drives.

Example for VACON® 100 family AC drive: 00:21:99:1a:00:24

Example for VACON® NXS/NXP: 0021991a0024

6.1.12 MODBUS UNIT IDENTIFIER

This value is used to select Modbus unit identifier / slave address. When using Modbus TCP the value 255 must be used, and this field is ignored as the IP address is used to access the correct device. When using Modbus UDP the values and their significance is explained in table below. Values from 1 to 247 and 255 can be set to OPTE9.

Table 14. Modbus Unit Identifier field description when using Modbus UDP

#	Unit identifier	Description
0	Broadcast	Broadcast address, messages are accepted by all devices
1...247	Slave address	Messages with this unit identifier and broadcast (0) are accepted
255	Non-significant	Messages with all unit identifiers are accepted (setting is ignored)

The value 0 can be used to control several devices with a broadcast message, e.g. to command all devices to stop at the same time. This feature will also work if all devices have the unit identifier value 255.

6.2 COMMUNICATION MODE

The OPTE9 option board shall support multiple communication modes to AC drive in future release. This will, among other features, enable transmitting and receiving 16 process data items at 1 ms interval.

6.3 CONTROL AND STATUS WORD MONITORING VALUES

Drive Control Word will always show the internal control word (FBFixedControlWord) which is written to the drive by the option board. If the control word written by the PLC does not use FBFixedControlWord (e.g. STW1 or CIP CW), the control word along with profile specific state machine is used to generate the FBFixedControlWord. If the used telegram is already using FBFixedControlWord, it is shown directly in this monitoring value. Only exception to this is that, in the VACON® NX AC drives, the bit 15 is set/removed to indicate "Master Connection state".

The Drive Status word will always show the FBFixedStatusWord received from the drive.

The Protocol Control Word shows the value which was sent by the PLC to the option board. It will always show protocol specific control word (ZSW1, CIP CW) if it is in the used telegram. Otherwise the FBGeneralControlWord is shown. However, if the telegram contains only the FBFixedControlWord, then this is shown in both control word monitoring values.

The Protocol Status word shows the value which was sent by the option board to the PLC. It will always show protocol specific status word (STW1, CIP SW) if it is in the used telegram. Otherwise the FBGeneralStatusWord is shown. However, if telegram contains only FBFixedStatusWord, then this is shown in both status word monitoring values.

See telegram specific configuration in their own chapter in this document. For example for PROFINET ST1 see Chapter 8.3.2.1 "Standard Telegram 1 and variants".

7. MODBUS TCP / MODBUS UDP

Modbus is a communication protocol developed by Modicon systems. In simple terms, it is a way of sending information between electronic devices. The device requesting the information is called the Modbus Master (or the Client in Modbus TCP/UDP) and the devices supplying information are Modbus Slaves (in Modbus TCP/UDP servers). In a standard Modbus network, there is one Master and up to 247 Slaves, each with a unique Slave Address from 1 to 247. The Master can also write information to the Slaves. Modbus is typically used to transmit signals from instrumentation and control devices back to the main controller or data gathering system.

The Modbus communication interface is built around messages. The format of these Modbus messages is independent of the type of physical interface used. The same protocol can be used regardless of the connection type. Because of this, Modbus gives the possibility to easily upgrade the hardware structure of an industrial network, without the need for large changes in the software. A device can also communicate with several Modbus nodes at once, even if they are connected with different interface types, without the need to use a different protocol for every connection.

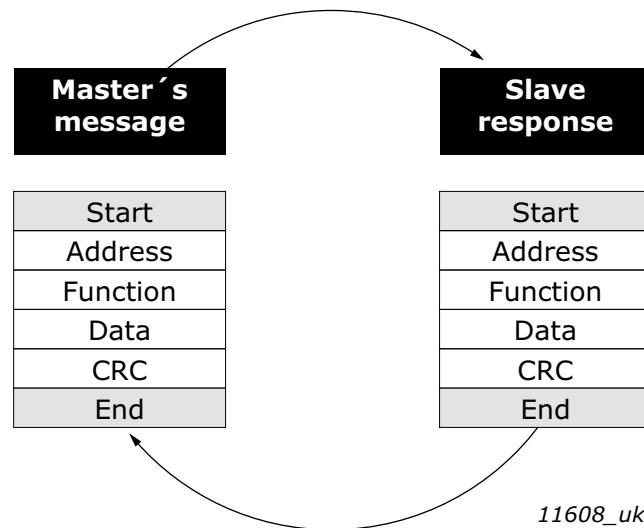

Figure 30. Basic structure of Modbus frame

On simple interfaces like RS485, the Modbus messages are sent in plain form over the network. In this case, the network is dedicated to Modbus. When using more versatile network systems like TCP/IP over Ethernet, the Modbus messages are embedded in packets with the format necessary for the physical interface. In that case Modbus and other types of connections can co-exist at the same physical interface at the same time. Although the main Modbus message structure is peer-to-peer, Modbus is able to function on both point-to-point and multidrop networks.

Each Modbus message has the same structure. Four basic elements are present in each message. The sequence of these elements is the same for all messages, to make it easy to parse the content of the Modbus message. A conversation is always started by a master in the Modbus network. A Modbus master sends a message and depending of the contents of the message a slave takes action and responds to it. There can be more than one master in a Modbus network. Addressing in the message header is used to define which device should respond to a message. All other nodes on the Modbus network ignore the message if the address field does not match their own address.

If you need to contact VACON® service in problems related to Modbus TCP/UDP, send a description of the problem together with the Drive Info File to tech.supportVDF@vacon.com. If possible, also send a "Wireshark" log from the situation if applicable.

7.1 MODBUS UDP vs TCP

In addition to TCP, the OPTE9 option board supports also UDP (from OPTE9 firmware version V006). It is recommended that UDP is used when reading and writing rapidly and repetitively (cyclically) same data as in case of process data. TCP must be used for single operations, like service data (e.g. reading or writing parameter values).

The key difference between UDP and TCP is that when using TCP each and every Modbus frame needs to be acknowledged by the receiver (see the figure below). This adds extra traffic to the network and more load to the system (PLC and drives) because software needs to keep track of sent frames to make sure that they have reached their destination.

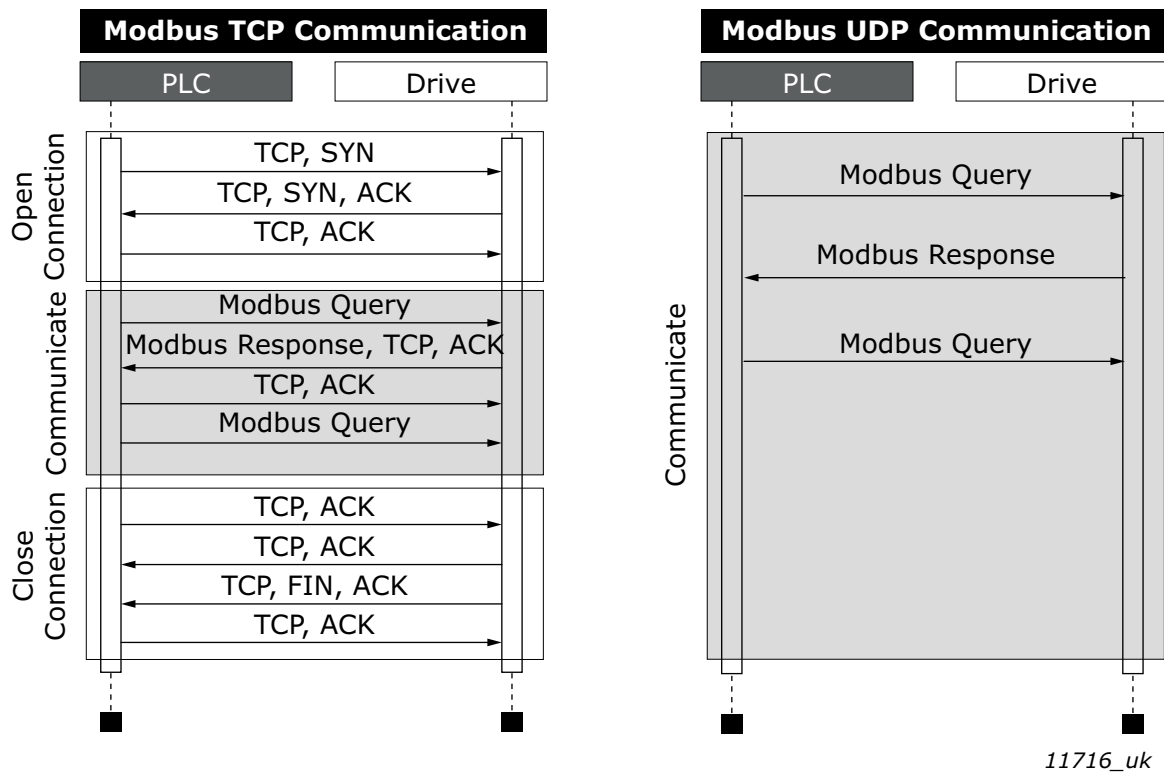
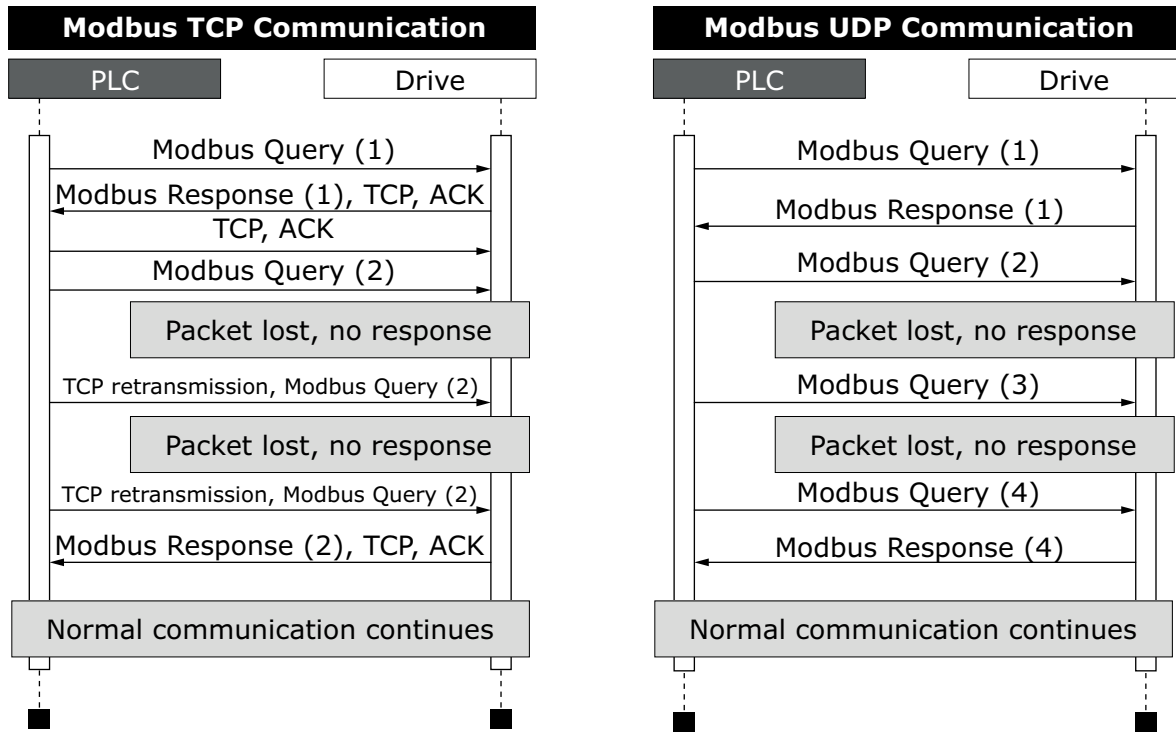

Figure 31. Modbus TCP and UDP communication comparison

Another difference between TCP and UDP is that UDP is connectionless. TCP connections are always opened with TCP SYN messages and closed with TCP FIN or TCP RST. With UDP, the first packet is already a Modbus query. The OPTE9 treats IP address and port combination as a connection. If port changes, it is considered as a new connection or as a second connection if both stay active.

When using UDP, it is not guaranteed that the sent frame reaches its destination. PLC must keep track of the Modbus requests by using the Modbus transaction id-field. It actually must do this also when using TCP. If PLC does not receive response in time from drive in UDP connection, it needs to send the query again. When using TCP, the TCP/IP stack will keep resending the request until it has been acknowledged by the receiver (see Figure 32). If PLC sends new queries during this time, some of those may not be sent to network (by TCP/IP stack) until previous sent package(s) has been acknowledged. This can cause small packet storms when the connection is resumed between PLC and drive (See Figure 33).



11717_uk

Figure 32. Modbus TCP and UDP communication errors comparison

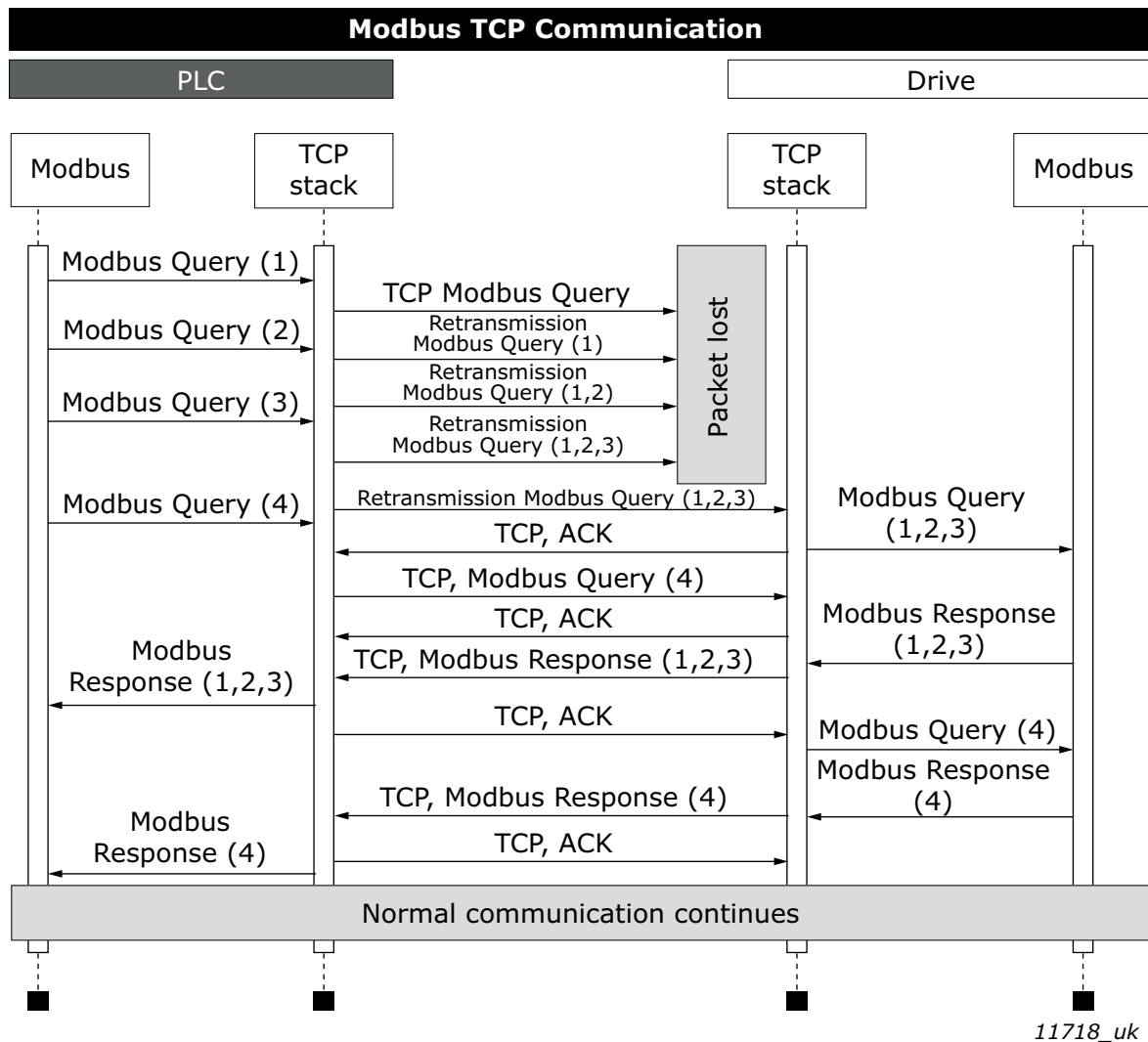

Figure 33. Modbus TCP retransmissions

Losing one packet is not a big issue because the same request can be sent again after timeout. In TCP, the packages always reach their destination but if network congestion causes retransmissions, those packages will most likely contain old data or instructions when they reach their destination.

7.2 MODBUS COMMUNICATIONS

The Modbus-VACON® interface features are presented below:

- Direct control of VACON® AC drive (e.g. Run, Stop, Direction, Speed reference, Fault reset)
- Access to VACON® parameters
- VACON® status monitoring (e.g. Output frequency, Output current, Fault code)

7.3 DATA ADDRESSES IN MODBUS MESSAGES

All data addresses in Modbus messages are referenced to zero. The first occurrence of a data item is addressed as item number zero. For example:

- The coil known as 'Coil 1' in a programmable controller is addressed as 'Coil 0000' in the data address field of a Modbus message.
- Coil 127 decimal is addressed as 'Coil 007E hex' (126 decimal).
- Holding register 40001 is addressed as register 0000 in the data address field of the message. The function code field already specifies a 'holding register' operation. Therefore the '4XXXX' reference is implicit.
- Holding register 40108 is addressed as register 006B hex (107 decimal).

7.3.1 MODBUS MEMORY MAP

The VACON® variables and fault codes as well as the parameters can be read and written from Modbus. The parameter addresses are determined in the application. Every parameter and actual value has been given an ID number in the application. The ID numbering of the parameters as well as the parameter ranges and steps can be found in the application manual in question. The parameter value are given without decimals. If several parameters/actual values are read with one message, the addresses of the parameters/actual values must be consecutive.

Table 15. Supported functions

Function code	Current terminology	Access type	Address range (hex)
1 (0x01)	Read coils	Discrete	00000-0FFFF
2 (0x02)	Read Input Discrete	Discrete	10000-1FFFF
3 (0x03)	Read holding registers	16bit	40000-4FFFF
4 (0x04)	Read input registers	16bit	30000-3FFFF
5 (0x05)	Force single coils	Discrete	00000-0FFFF
6 (0x06)	Write single register	16bit	40000-4FFFF
15 (0x0F)	Force multiple coils	Discrete	00001-0FFFF
16 (0x10)	Write multiple registers	16bit	40000-4FFFF
23 (0x17)	Read/Write multiple registers	16bit	40000-4FFFF

NOTE! Broadcasting is not supported in TCP.

7.3.2 MODBUS DATA MAPPING

7.3.2.1 Coil registers

Coil registers contain binary data (Read/Write). See Table 16.

Table 16. Defined coil registers

Address	Function	Purpose
0001	RUN/STOP	Control Word, bit 0
0002	Direction	Control Word, bit 1
0003	Fault reset	Control Word, bit 2
0017	Reset	Clears operation days trip counter
0018	Reset	Clears energy trip counter

7.3.2.2 Clearing resettable counters

The VACON® AC drives have trip counters for operation days and energy. These counters can be reset to zero by writing value '1' to addresses defined in Table 17. Resetting the counters is not supported in VACON® 20, VACON® 20 X or VACON® 20 CP.

Table 17. Clearing trip counters

Address	Function	Purpose
40101	Reset	Clears operation days trip counter
40301	Reset	Clears energy trip counter

For compatibility with OPT-CI, these registers can be cleared also by writing '1' to these coils.

Address	Function	Purpose
0017	Reset	Clears operation days trip counter
0018	Reset	Clears energy trip counter

7.3.2.3 Input Discrete registers

Input discrete registers contain binary data (Read). See Table 18.

Table 18. Defined Input Discrete registers

Address	Function	Purpose
10001	Ready	Status Word, bit 0
10002	Run	Status Word, bit 1
10003	Direction	Status Word, bit 2
10004	Fault	Status Word, bit 3
10005	Alarm	Status Word, bit 4
10006	At reference	Status Word, bit 5
10007	Zero speed	Status Word, bit 6
10008	Flux ready	Status Word, bit 7

7.3.2.4 Input registers

The values can be read with function code 4. These are for compatibility with the OPT-CI option board. They return the same values as holding register counterparts.

Table 19.

Address range	Purpose	Access type	See	R/W	Max R/W size
1 - 5	Operation day counter	16bit	Table 27	RO	5/0
101 - 105	Resettable operation day counter	16bit	Table 29	R, Write 1 to first index to reset	5/0
201 - 203	Energy counter	16bit	Table 31	RO	5/0
301 - 303	Resettable energy counter	16bit	Table 33	R, Write 1 to first index to reset	5/0
401 - 430	Fault history	16bit	Table 34	RO	30/0

7.3.2.5 Holding registers

The values can be read with function code 3. Modbus registers are mapped to drive IDs as follows:

Table 20. Defined holding registers

Address range	Purpose	Access type	See	R/W	Max R/W size
0001 - 2000	VACON® Application IDs	16bit	Table 21	RW	30/30
2001 - 2019	FBProcessDataIN	16bit	Table 22	RW	19/19
2051 - 2086	FBProcessDataIN	32bit ¹⁾	Table 22	RW	36/36
2101 - 2119	FBProcessDataOUT	16bit	Table 23	RO	19/0
2151 - 2186	FBProcessDataOUT	32bit ¹⁾	Table 23	RO	36/0
2200 - 10000	VACON® Application IDs	16bit	Table 21	RW	30/30
10501 - 10530	IDMap	16bit	Figure 34	RW	30/30
10601 - 10630	IDMap Read/Write	16bit	Table 24	RW	30/30 ²⁾
10701 - 10760	IDMap Read/Write	32bit ¹⁾	Table 24	RW	30/30
20001 - 40000	VACON® Application IDs	32bit ¹⁾	Table 21	RW	30/30
40001 - 40005	Operation day counter	16bit	Table 27	RO	5/0
40011 - 40012	Operation day counter	32bit ¹⁾	Table 26	RO	2/0
40101 - 40105	Resettable operation day counter	16bit	Table 29	R, Write 1 to first index to reset	5/0
40111 - 40112	Resettable operation day counter	32bit	Table 28	RO	2/0
40201 - 40203	Energy counter	16bit	Table 31	RO	3/0
40211 - 40212	Energy counter	32bit	Table 30	RO	2/0
40301 - 40303	Resettable energy counter	16bit	Table 33	R, Write 1 to first index to reset	3/0
40311 - 40312	Resettable energy counter	32bit	Table 32	RO	2/0
40400	Reset fault history	16bit		RW	1/1
40401 - 40430	Fault history	16bit	Table 34	RO	30/0
40501	Communication time-out	16bit	Table 36	RW	1/1
40511-40568	Fault history with 16 bit fault codes	16bit	Table 35	RO	30/0

¹⁾ These items are supported only in VACON® 100 family AC drives. Not supported in current version. See chapter 5.

²⁾ In VACON® 20, VACON® 20 X and VACON® 20 CP, the maximum R/W size for IDmap operations is 12/30.

7.3.2.5.1. VACON® APPLICATION IDS

Application IDs are parameters that depend on the drive's application. These parameters can be read and written by pointing the corresponding memory range directly or by using the so-called ID map (more information below). The easiest way to read a single parameter value or parameters with consecutive ID numbers is to use a straight address. It is possible to read 30 consecutive ID addresses. Notice that the operation will fail if even one of the consecutive IDs do not exist.

Parameters which have 32 bit value can be read from their own range. For example, if you want to read the value for ID 864 (FB Status Word), the address must be set to 21726. This address value comes from values: $20000 + ((ID - 1) * 2)$. The ID value is reduced with one because of zero-based addressing and the result is multiplied with 2 because one 32 bit value will take two (16 bit) addresses.

Table 21. Parameter IDs

Address range	Purpose	ID range
0001-2000	16 bit application parameters	1-2000
2200-10000	16 bit application parameters	2200-10000
20001-40000	32 bit application parameters	1-10000

7.3.2.5.2. FB PROCESS DATA IN

The process data fields are used to control the AC drive (e.g. Run, Stop, Reference, Fault Reset) and to quickly read actual values (e.g. Output frequency, Output current, Fault code). The values in these indexes can be read and written. The fields are structured as follows (continued on the next page):

Process Data Master -> Slave (max 22 bytes)

Table 22. Fieldbus Process Data IN

Address		Name	Range/Type
16-bit	32-bit*		
2001	2051 = High data 2052 = Low data	FB Control Word	Binary coded
2002	-	FB General Control Word	Binary coded
2003	2053 = High data 2054 = Low data	FB Speed Reference	0...10000 (100%)

Address		Name	Range/Type
16-bit	32-bit*		
2004	2055 = High data 2056 = Low data	FB Process Data In 1	See Chapter 11 "APPENDIX 1 - PROCESS DATA"
2005	2057 = High data 2058 = Low data	FB Process Data In 2	
2006	2059 = High data 2060 = Low data	FB Process Data In 3	
2007	2061 = High data 2062 = Low data	FB Process Data In 4	
2008	2063 = High data 2064 = Low data	FB Process Data In 5	
2009	2065 = High data 2066 = Low data	FB Process Data In 6	
2010	2067 = High data 2068 = Low data	FB Process Data In 7	
2011	2069 = High data 2070 = Low data	FB Process Data In 8	
2012*	2071 = High data 2072 = Low data	FB Process Data In 9	
2013*	2073 = High data 2074 = Low data	FB Process Data In 10	
2014*	2075 = High data 2076 = Low data	FB Process Data In 11	
2015*	2077 = High data 2078 = Low data	FB Process Data In 12	
2016*	2079 = High data 2080 = Low data	FB Process Data In 13	
2017*	2081 = High data 2082 = Low data	FB Process Data In 14	
2018*	2083 = High data 2084 = Low data	FB Process Data In 15	
2019*	2085 = High data 2086 = Low data	FB Process Data In 16	

* Available in future release

Control word bits

See Chapter 12 "APPENDIX 2 - CONTROL AND STATUS WORD" for control word bit descriptions.

Control Word Monitoring values

Drive Control Word and Protocol Control Word monitoring values will always show the same value when using Modbus. It is the same value as received from network. The only exception to this is that when using the VACON® NX AC drives, the bit 15 of the Control word is changed to indicate the "Master connection status". The bit 15 is set to 1 when master device has written process data and the bit is cleared when the connection is closed/lost.

7.3.2.5.3. FB PROCESS DATA OUT

Values in these indexes can be only read, not written.

Table 23. Fieldbus Process Data OUT

Address		Name	Range/Type
16-bit	32-bit*		
2101	2151 = High data 2152 = Low data	FB Status Word	Binary coded
2102	-	In case of 16-bit, FB General Status Word (High data)	Binary coded
2103	2153 = High data 2154 = Low data	FB Actual Speed	0...10000 (100.00%)
2104	2155 = High data 2156 = Low data	FB Process Data Out 1	See Chapter 11 "APPENDIX 1 - PROCESS DATA"
2105	2157 = High data 2158 = Low data	FB Process Data Out 2	
2106	2159 = High data 2160 = Low data	FB Process Data Out 3	
2107	2161 = High data 2162 = Low data	FB Process Data Out 4	
2108	2163 = High data 2164 = Low data	FB Process Data Out 5	
2109	2165 = High data 2166 = Low data	FB Process Data Out 6	
2110	2167 = High data 2168 = Low data	FB Process Data Out 7	
2111	2169 = High data 2170 = Low data	FB Process Data Out 8	
2112*	2171 = High data 2172 = Low data	FB Process Data Out 9	
2113*	2173 = High data 2174 = Low data	FB Process Data Out 10	
2114*	2175 = High data 2176 = Low data	FB Process Data Out 11	
2115*	2177 = High data 2178 = Low data	FB Process Data Out 12	
2116*	2179 = High data 2180 = Low data	FB Process Data Out 13	
2117*	2181 = High data 2182 = Low data	FB Process Data Out 14	
2118*	2183 = High data 2184 = Low data	FB Process Data Out 15	
2119*	2185 = High data 2186 = Low data	FB Process Data Out 16	

* Available in future release

Status Word bits

See Chapter 12 "APPENDIX 2 - CONTROL AND STATUS WORD" for status word bit descriptions.

The use of process data depends on the application. In a typical situation, the device is started and stopped with the Control Word (CW) written by the Master and the Rotating speed is set with Reference (REF). With PD1...PD16 the device can be given other reference values (e.g. Torque reference).

With the Status Word (SW) read by the Master, the status of the device can be seen. Actual Value (ACT) and PD1...PD16 show the other actual values.

Status Word Monitoring values

The Drive Status Word and Protocol Status Word monitoring values will always show the same value when using Modbus. It is the same value than what is sent to the network.

7.3.2.5.4. ID MAP

Using the ID map, you can read consecutive memory blocks that contain parameters whose IDs are not in a consecutive order. The address range 10501 - 10530 is called 'IDMap', and it includes an address map in which you can write your parameter IDs in any order. The address range 10601 - 10630 is called 'IDMap Read/Write', and it includes values for parameters written in the IDMap. As soon as one ID number has been written in the map cell 10501, the corresponding parameter value can be read and written in the address 10601, and so on. The address range 10701 - 10760 contains the ID Map for 32bit values. Maximum of 30 IDs and ID values can be written and read with single request except in VACON® 20 and 20 X/CP it is possible to access only 12 ID value items at a time.

NOTE! 32 bit data not supported in the current version. See chapter 5.

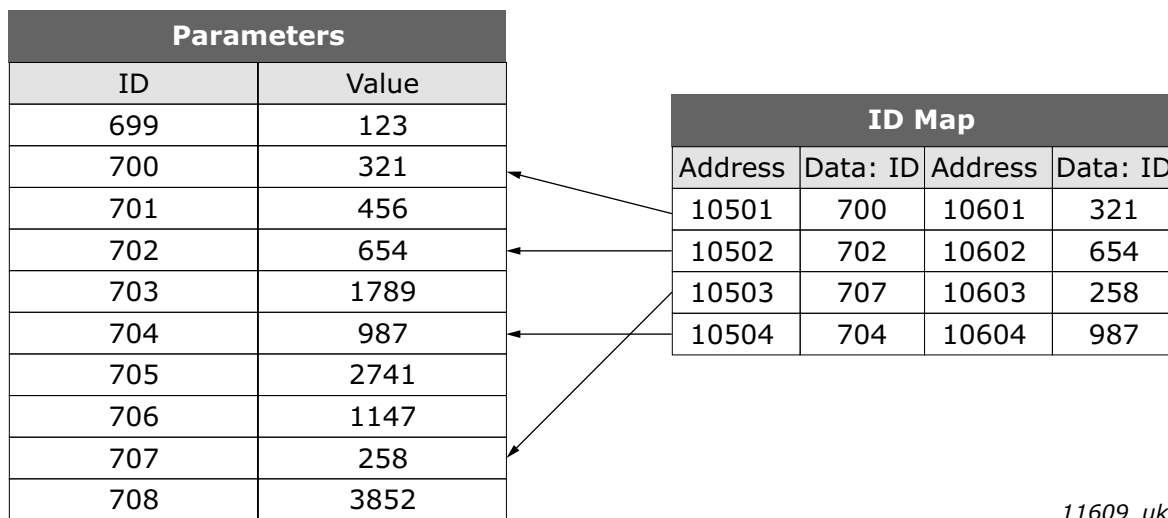

11609_uk

Figure 34. ID Map initialization example

Once the ID Map address range has been initialized with the parameter IDs, the parameter values can be read and written in the IDMap Read/Write address range address (IDMap address + 100).

Table 24. Parameter Values in 16-bit IDMap Read/Write registers

Address	Data
10601	Data included in parameter ID700
10602	Data included in parameter ID702
10603	Data included in parameter ID707
10604	Data included in parameter ID704

If the ID Map table has not been initialized, all the fields show index as '0'. If it has been initialized, the parameter IDs included in it are stored in the flash memory of the OPTE9 option board.

Table 25. Example of parameter values in 32-bit IDMap Read/Write registers

Address	Data
10701	Data High, parameter ID700
10702	Data Low, parameter ID700
10703	Data High, parameter ID702
10704	Data Low, parameter ID702

7.3.2.5.5. OPERATION DAY COUNTER

Control unit operating time counter (total value). This counter cannot be reset. The values are read only.

NOTE! The feature Operation day counter does not work with VACON[®] 20, VACON[®] 20 X or VACON[®] 20 CP AC drives.

Operation day counter as seconds

This counter in registers 40011d to 40012d holds the value of operation days as seconds in a 32-bit unsigned integer.

Table 26. Operation days counter as seconds

Address	Description
40011 High data 40012 Low data	Holds the counter value as seconds.

Operation day counter

This counter in registers 40001d to 40005d holds the value of operation days counter. The values are read only.

For compatibility with VACON[®] 100 family internal Modbus TCP/UDP and the OPT-CI option board, this counter is found from two different register areas: holding registers 40001d to 40005d and input registers 1d to 5d.

Table 27. Operation day counter

Holding register address	Input register address	Purpose
40001	1	Years
40002	2	Days
40003	3	Hours
40004	4	Minutes
40005	5	Seconds

7.3.2.5.6. RESETTABLE OPERATION DAY COUNTER

This register holds the value for resettable control unit operating time counter (trip value). The values are read only.

For resetting this counter see Chapter 7.3.2.2 "Clearing resettable counters".

NOTE! The feature Resettable operation day counter does not work with VACON® 20, VACON® 20 X or VACON® 20 CP AC drives.

Resettable operation day counter as seconds

This counter in registers 40111d to 40112d holds the value of resettable operation days as seconds in a 32-bit unsigned integer.

Table 28. Resettable operation days counter as seconds

Address	Description
40111 High data 40112 Low data	Holds the counter value as seconds.

Resettable operation day counter

This counter in registers 40101d to 40105d holds the value of operation days counter.

For compatibility with VACON® 100 family internal Modbus TCP/UDP and the OPT-CI option board, this counter is found from two different register areas: holding registers 40101d to 40105d and input registers 30101d to 30105d.

Table 29. Resettable operation day counter

Holding register address	Input register address	Purpose
40101	101	Years
40102	102	Days
40103	103	Hours
40104	104	Minutes
40105	105	Seconds

7.3.2.5.7 ENERGY COUNTER

This counter holds the value of total amount of energy taken from a supply network. This counter cannot be reset. The values are read only.

Energy counter as kWh

This counter is in registers 40211d to 40212d and is a 32-bit floating point (IEEE 754) value containing the number of kilowatt-hours (kWh) that is in the drive's energy counter. This value is read-only.

Table 30. Energy counter as kWh

Address	Description
40211 High data 40212 Low data	Holds the value of energy counter in kWh. Datatype is 32 bit float IEEE 754

Energy counter

These registers hold three values for the energy counter, amount of energy used, format of the energy value and unit of the energy value.

For compatibility with VACON® 100 family internal Modbus TCP/UDP and the OPT-CI option board, this counter is found from two different register areas: holding registers 40201d to 40203d and input registers 201d to 203d.

Example: If energy = 1200, format = 52, unit = 1, then actual energy is 12.00 kWh.

Table 31. Energy counter

Holding register address	Input register address	Purpose	Description
40201	201	Energy	Amount of energy taken from a supply network.
40202	202	Format	The last number of the Format field indicates the decimal point place in the Energy field. Example: 40 = 4 number of digits, 0 fractional digits 41 = 4 number of digits, 1 fractional digit 42 = 4 number of digits, 2 fractional digits
40203	203	Unit 1 = kWh 2 = MWh 3 = GWh 4 = TWh	Unit of the value.

7.3.2.5.8. RESETTABLE ENERGY COUNTER

This counter holds the value of total amount of energy taken from a supply network since the counter was last reset. For resetting this counter see Chapter 7.3.2.2 "Clearing resettable counters". The values are read only.

Resettable energy counter as kWh

This counter is in registers 40311d to 40312d and is a 32-bit floating point (IEEE 754) value containing the number of kilowatt-hours (kWh) that is in the drive's resettable energy counter.

Table 32. Resettable energy counter as kWh

Address	Description
40311 High data 40312 Low data	Holds the value of energy counter in kWh since last counter reset. Datatype is 32 bit float IEEE 754

Resettable energy counter

These registers hold three values for the energy counter, amount of energy used, format of the energy value and unit of the energy value.

For compatibility with VACON® 100 family internal Modbus TCP/UDP and the OPT-CI option board, this counter is found from two different register areas: 40301d to 40303d and 301d to 303d.

Example: If energy = 1200, format = 52, unit = 1, then actual energy is 12.00 kWh.

Table 33. Resettable energy counter

Holding register address	Input register address	Purpose	Description
40301	301	Energy	Amount of energy taken from a supply network.
40302	302	Format	The last number of the Format field indicates the decimal point place in the Energy field. Example: 40 = 4 number of digits, 0 fractional digits 41 = 4 number of digits, 1 fractional digit 42 = 4 number of digits, 2 fractional digits
40303	303	Unit 1 = kWh 2 = MWh 3 = GWh 4 = TWh	Unit of the value.

7.3.2.5.9. FAULT HISTORY

The fault history can be viewed by reading from address 40401 onward. The faults are listed in chronological order so that the latest fault is mentioned first and the oldest last. The fault history can contain 29 faults at the same time. (In VACON® 20, VACON® 20 X and VACON® 20 CP it is possible to read nine faults). For compatibility with VACON® 100 family internal Modbus TCP/UDP and the OPT-CI option board, this counter is also found from input register area: 401d to 403d.

NOTE! Reading the fault history items is slow. Reading all 30 items at once might take up to three seconds.

The fault history contents are represented as follows:

Table 34. Fault history

Holding register address	Input register address	Purpose
40401	401	Upper byte is a fault code, lower byte is a sub code
40402	402	
40403	403	
...	...	
40429	429	

7.3.2.5.10. FAULT HISTORY WITH 16-BIT ERROR CODES

The fault history can be viewed by reading from address 40511 onward. The faults are listed in a chronological order so that the latest fault is mentioned first and the oldest last. These addresses contain the fault code and the subcode for the fault. Reading can be started from any address. (In VACON® 20, VACON® 20 X and VACON® 20 CP it is possible to read nine faults).

NOTE! Reading the fault history items is slow. Reading all 30 items at once might take up to three seconds.

Table 35. Fault history with 16-bit error codes

Holding register address	Purpose	Description
40511	Fault code 1	16-bit fault code in index 1.
40512	Sub code 1	16-bit sub code for the fault in index 1.
40513	Fault code 2	16-bit fault code in index 2.
40514	Sub code 2	16-bit sub code for the fault in index 2.
...	...	
40567	Fault code 29	
40568	Sub code 29	

7.3.2.5.11. RESET FAULT HISTORY

Drive fault history can be reset by writing "1" to address 40400. Value in this address can be read but it is always zero.

7.4 MODBUS COMMUNICATION AND CONNECTION TIMEOUT

It is possible to open up to three connections to the OPTE9 option board. One of the connections could be used for process data and other just for reading monitoring data. In most cases it is desirable that if "monitor" connection gets disconnected, no fault is generated but when the connection is handling the process data, a fault should be generated in the time specified.

This register address enables the user to give custom communication timeout for each connection. If a custom timeout value is used, it must be given every time a connection is opened. Timeout can be set only to the connection which is been used to access this register. By default the connection uses the communication timeout value given via panel parameters.

If the cable is disconnected, a fieldbus fault is activated after the timeout period. When communication timeout is zero, no fault is activated.

Table 36. Communication timeout register

Holding register address	Purpose	Description
40501	Communication timeout	Connection timeout value for this connection in seconds.

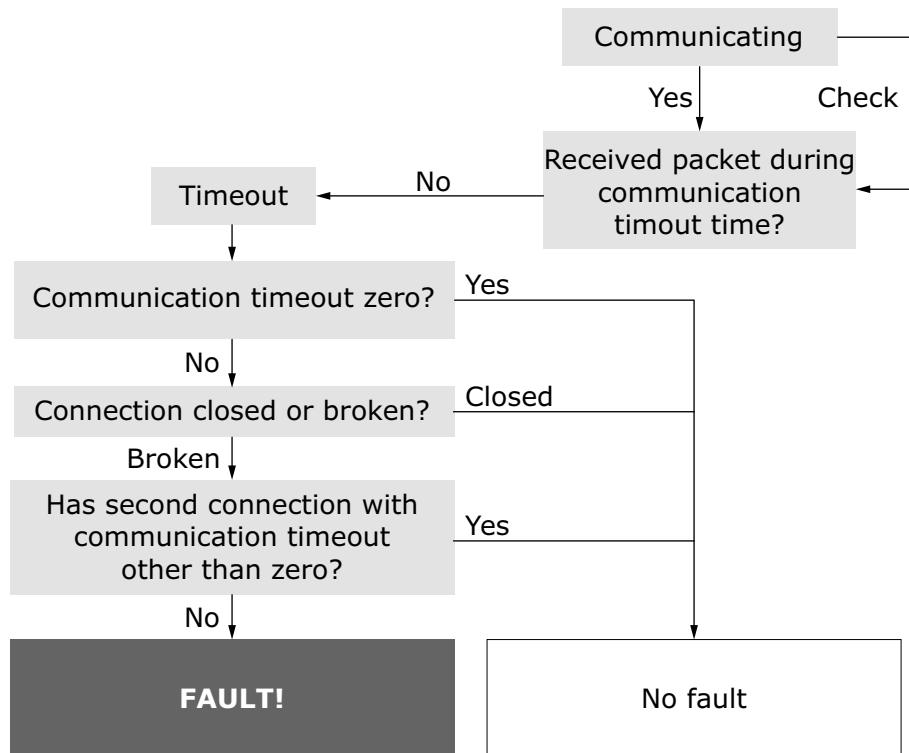

7092_uk

Figure 35. The Modbus TCP/UDP function in case of timeout

7.5 QUICK SETUP

Following these instructions, you can easily and fast set up your Modbus for use:

In the AC drive application: Choose Fieldbus as the active control place (see AC drives User's Manual).

In the Master software:

1. Set the settings in the master software.
2. Set the Control Word to '0' (2001).
3. Set the Control Word to '1' (2001).
4. Drive's status is RUN.
5. Set the Reference value to '5000' (50.00%) (2003).
6. Actual speed is 5000 (25.00 Hz if MinFreq is 0.00 Hz and MaxFreq is 50.00 Hz).
7. Set the Control Word to '0' (2001).
8. Drive's status is STOP.

7.6 MODBUS - EXAMPLE MESSAGES

7.6.1 EXAMPLE 1 - WRITE PROCESS DATA

Write the process data 42001...42003 with command 16 (Preset Multiple Registers).

Command Master - Slave:

ADDRESS		01 hex	Slave address 1 hex (= 1)
FUNCTION		10 hex	Function 10 hex (= 16)
DATA	Starting address HI	07 hex	Starting address 07D0 hex (= 2000)
	Starting address LO	D0 hex	
	No. of registers HI	00 hex	Number of registers 0003 hex (= 3)
	No. of registers LO	03 hex	
	Byte count	06 hex	Byte count 06 hex (= 6)
	Data HI	00 hex	Data 1 = 0001 hex (= 1). Setting control word run bit to 1.
	Data LO	01 hex	
	Data HI	00 hex	Data 2 = 0000 hex (= 0).
	Data LO	00 hex	
	Data HI	13 hex	Data 3 = 1388 hex (= 5000), Speed Reference to 50.00%
Data LO	88 hex		
ERROR CHECK	CRC HI	C8 hex	CRC field C8CB hex (= 51403)
	CRC LO	CB hex	

Message frame:

01	10	07	D0	00	03	06	00	01	00	00	13	88	C8	CB
----	----	----	----	----	----	----	----	----	----	----	----	----	----	----

The reply to Preset Multiple Registers message is the echo of 6 first bytes.

Answer Slave - Master:

ADDRESS		01 hex	Slave address 1 hex (= 1)
FUNCTION		10 hex	Function 10 hex (= 16)
DATA	Starting address HI	07 hex	Starting address 07D0 hex (= 2000)
	Starting address LO	D0 hex	
	No. of registers HI	00 hex	Number of registers 0003 hex (= 3)
	No. of registers LO	03 hex	
ERROR CHECK	CRC HI	80 hex	CRC 8085 hex (= 32901)
	CRC LO	85 hex	

Reply frame:

01	10	07	D0	00	03	80	85
----	----	----	----	----	----	----	----

7.6.2 EXAMPLE 2 - READ PROCESS DATA

Read the Process Data 42103...42104 with command 4 (Read Input Registers).

Command Master - Slave:

ADDRESS		01 hex	Slave address 1 hex (= 1)
FUNCTION		04 hex	Function 4 hex (= 4)
DATA	Starting address HI	08 hex	Starting address 0836 hex (= 2102)
	Starting address LO	36 hex	
	No. of registers HI	00 hex	Number of registers 0002 hex (= 2)
	No. of registers LO	02 hex	
ERROR CHECK	CRC HI	93 hex	CRC 93A5 hex (= 37797)
	CRC LO	A5 hex	

Message frame:

01	04	08	36	00	02	93	A5
----	----	----	----	----	----	----	----

The reply to the Read Input Registers message contains the values of the read registers.

Answer Slave - Master:

ADDRESS		01 hex	Slave address 1 hex (= 1)
FUNCTION		04 hex	Function 4 hex (= 4)
DATA	Byte count	04 hex	Byte count 4 hex (= 4)
	Data HI	13 hex	Speed reference = 1388 hex (=5000 => 50.00%)
	Data LO	88 hex	
	Data HI	09 hex	Output Frequency = 09C4 hex (=2500 =>25.00Hz)
	Data LO	C4 hex	
ERROR CHECK	CRC HI	78 hex	CRC 78E9 hex (= 30953)
	CRC LO	E9 hex	

Reply frame:

01	04	04	13	88	09	C4	78	E9
----	----	----	----	----	----	----	----	----

7.6.3 EXAMPLE 3 - EXCEPTION RESPONSE

In an exception response, the Slave sets the most-significant bit (MSB) of the function code to 1. The Slave returns an exception code in the data field.

Command Master - Slave:

ADDRESS		01 hex	Slave address 1 hex (= 1)
FUNCTION		04 hex	Function 4 hex (= 4)
DATA	Starting address HI	17 hex	Starting address 1770 hex (= 6000)
	Starting address LO	70 hex	
	No. of registers HI	00 hex	Invalid number of registers 0005 hex (= 5)
	No. of registers LO	05 hex	
ERROR CHECK	CRC HI	34 hex	CRC 3466 hex (= 13414)
	CRC LO	66 hex	

Message frame:

01	04	17	70	00	05	34	55
----	----	----	----	----	----	----	----

Exception response

Answer Slave - Master:

ADDRESS		01 hex	Slave address 1 hex (= 1)
FUNCTION		84 hex	Most significant bit set to 1
DATA	Error code	04 hex	Error code 04 => Slave device failure
ERROR CHECK	CRC HI	42 hex	CRC 42C3 hex (= 17091)
	CRC LO	C3 hex	

Reply frame:

01	84	04	42	C3
----	----	----	----	----

8. PROFINET IO

PROFINET is the Ethernet-based automation standard of PROFIBUS International for the implementation of an integrated and consistent automation solution based on Industrial Ethernet. PROFINET supports the integration of simple distributed field devices and time-critical applications in (switched) Ethernet communication, as well as the integration of component-based distributed automation systems for vertical and horizontal integration of networks.

OPTE9 implements PROFINET IO version 2.3 with conformance class B and the highest netload class (class III), making it suitable for use in larger automation systems. OPTE9 also implements PROFINET IO alarms system where VACON® AC drive faults are seen in bus as PROFINET IO alarms.

8.1 PROFIDRIVE 4.1 PROFILE

To provide interoperability between devices from different manufacturers, a "standard" must be defined so that:

- The devices behave in the same way.
- They produce and/or consume the same basic set of I/O data.
- They contain the same basic set of configurable attributes.

The formal definition of this information is known as a device profile.

Some AC drives may support only some of the functionality. See Chapter 12.3 "**Control word bit support in drives**".

8.2 PROFIDRIVE 4.1 STATE MACHINE

STW1 (Control Word) and ZSW1 (Status Word) follow the state machine presented below:

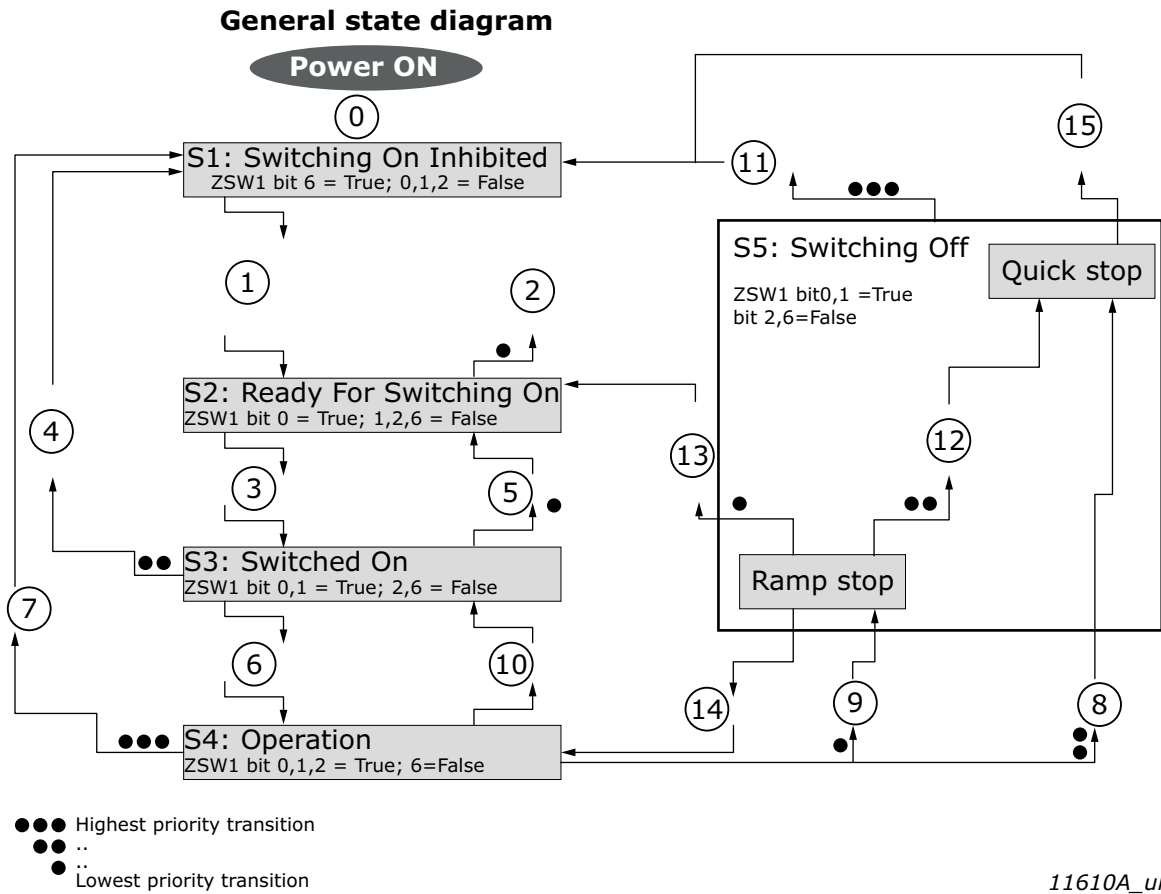

Figure 36. General state diagram

NOTE! When using VACON® NX series AC drives and OPTE9 in "PROFIdrive" mode, the stop command always follows the configured stop mode and not the stop command given from fieldbus.

NOTE! Quick stop only occurs if the application supports it. If the application does not support Quick stop, a normal ramp stop is executed.

Table 37. PROFIdrive state machine commands

#	Bits of control word	Value (hex)	Action(s)		
			VACON® 100 family & VACON® 20X/CP	VACON® 20	VACON® NXP
0	-	-	Self-initiation is performed		
1	OFF AND No Coast Stop AND No Quick Stop STW1 bit 0 = False; 1, 2 = True	0x47E	None, requires that Drive is READY (ZSW1 status word bit 13)		
2	Coast Stop OR Quick Stop STW1 bit 1 = False OR bit 2 = False		None		
3	ON STW1 bit 0 = True	0x477	None		
4	Coast Stop OR Quick Stop		None		

Table 37. PROFIdrive state machine commands

#	Bits of control word	Value (hex)	Action(s)		
			VACON® 100 family & VACON® 20X/CP	VACON® 20	VACON® NXP
5	STW1 bit 1 = False OR bit 2 = False		None		
6	Enable operation STW1 bit 3 = True	0x47F	Drive function is enabled, requires that Drive is in fieldbus control (ZSW1 status word bit 9		
7	Coast stop STW1 bit 1 = False	0x47D	Stop by coast	Stop by coast	Stop function
8, 12	Quick stop STW1 bit 2 = False	0x47B	Quick stop	Stop by ramp	Stop function
9	Ramp stop STW1 bit 0 = False	0x47E	Stop by ramp	Stop by ramp	Stop function
10	Disable operation STW1 bit 3 = False	0x477	Drive function is disabled, stop by stop function		
11	Coast stop STW1 bit 1 = False	0x47D	Stop by coast	Stop by coast	Stop function
13, 15	Standstill detected OR Disable operation STW1 bit 3 = False	0x477	Drive function is disabled, stop by stop function		
14	ON (Re-enable operation)	0x47F	Drive function is re-enabled		

8.3 PROFINET IO PROCESS COMMUNICATION

The PROFIdrive profile specifies telegrams used for process communication. The OPTE9 supports 4 type of different telegrams with and without extra process data items. These telegrams contain either PROFIdrive or VACON® specific signals or a combination of both.

It is also possible to use up to eight (8) Process Data fields, or sixteen (16) when using extended or fast communication mode. If the normal communication mode is used, the upper 8 Process Data items (9-16) are either zeroes (actual data) or not used (setpoint data). See chapter 6.2 for more details. The following chapters describe the different types of telegrams and the signals that form them.

8.3.1 CHOOSING TELEGRAM TYPE

When choosing a telegram for PROFINET IO communication, you need to take a few things into account, for example, if you need PROFIdrive control/status word (STW1/ZSW1) or if you could use VACON® control/status word.

We recommend you to use STW1 when you have devices from multiple manufactures which all can be controlled with PROFIdrive control word. This then makes writing the PLC application easier, especially if you have PROFIdrive block ready for your PLC.

State machine for VACON® control/status word is simpler than in the PROFIdrive and therefore controlling the drive is also easier in the PLC application. If you have only VACON® devices controlled by your PLC over PROFINET IO, then it is better to use VACON® control/status word.

Telegram selection also affects the motor speed control. With VACON® control word, the motor direction can be controlled with a single bit. PROFIdrive motor direction is controlled with negative/positive values. Telegrams with PROFIdrive control/status word generally have also PROFIdrive speed reference/actual (NIST_A/NSOLL_A). Other telegrams have VACON® speed reference/actual (FBSpeedReference/FBSpeedActual). The main difference between these types is the integer value which means maximum allowed motor speed (100%). In VACON® FBSpeedReference, the value is between 0d - 10000d (100.00%) and in PROFIdrive NIST_A the value is between -16384d - 16384d.

Note also that when you use NSOLL_A, our minimum and maximum frequency parameters affect the speed reference differently than when you use the FBSpeedReference directly. When you use NSOLL_A, the PROFINET will give zero reference to the application until NSOLL_A exceeds the minimum reference, but if you use the FBSpeedReference, the given value is always scaled between the minimum and maximum frequency. For example, if the Minimum Frequency is 30 Hz and the Maximum Frequency is 50Hz, the NSOLL_A value between 0 and 9830 will run 30Hz. If the FBSpeedReference is used, then for example value 1000 (10%) will run 32Hz

8.3.2 TELEGRAM TYPES

8.3.2.1 Standard Telegram 1 and variants

Standard Telegram 1 types are used, when a standard VACON® application is used and PROFIdrive functionality is required. These telegrams (Table 38) use PROFIdrive-defined control word, status word, speed setpoint value and speed actual value. When using these telegrams, the process data fields are communicated as 16-bit values.

STW1 will force edge sensitive run control.

NOTE! When board is connected to VACON® 100 family AC drive and its mode parameter is set to “NX Mode”, the option board will use FBSpeedReference/FBSpeedActual instead of NSOLL_A/ NIST_A as backward compatibility for OPTCP option board.

Table 38. Standard Telegram 1 and variants

Telegram No.	Telegram	Abbreviation
1	Standard Telegram 1	ST1
102	Standard Telegram 1 + 1 Process Data	ST1 + 1 PD
103	Standard Telegram 1 + 2 Process Data	ST1 + 2 PD
104	Standard Telegram 1 + 3 Process Data	ST1 + 3 PD
100	Standard Telegram 1 + 4 Process Data	ST1 + 4 PD
105	Standard Telegram 1 + 5 Process Data	ST1 + 5 PD
106	Standard Telegram 1 + 6 Process Data	ST1 + 6 PD
107	Standard Telegram 1 + 7 Process Data	ST1 + 7 PD
101	Standard Telegram 1 + 8 Process Data	ST1 + 8 PD
138	Standard Telegram 1 + 12 Process Data *	ST1 + 12 PD
139	Standard Telegram 1 + 16 Process Data *	ST1 + 16 PD

* 12 and 16 process data items will be available in future releases. At the moment, the incoming process data 9-16 is not handled. Outgoing process data 9-16 is zero.

Table 39. Standard Telegram 1 setpoint and actual data

Bytes	Setpoint	Actual value
1...2	STW1	8.3.3.1 ZSW1 8.3.3.2
3...4	NSOLL_A	8.3.3.3 NIST_A 8.3.3.4
5...6	PDI1	8.3.3.11
7...8	PDI2	
...	...	
19...20	PDI8	
21...22	PDI9*	
...	...	
35...36	PDI16*	

* Not used / zero if not supported (see chapter 6.2)

Control and Status Word monitoring values

When using this telegram, monitoring values contains values as shown in table below.

Table 40. Control and Status Word monitoring values

Name	Value
Drive CW	FBFixedControlWord
Drive SW	FBFixedStatusWord
Protocol CW	STW1
Protocol SW	ZSW1

8.3.2.2 VACON®-specific Telegram 1 and its variants

These telegrams (Table 41) use VACON®-defined control word, status word, speed setpoint value and speed actual value to directly access the AC drive application. When using these telegrams, the process data fields are communicated as 16-bit values.

Table 41. Vendor telegram 1 and variants

Telegram No.	Telegram	Abbreviation
108	Vendor Telegram 1	Vendor 1
109	Vendor Telegram 1 + 1 Process Data	Vendor 1 + 1 PD
110	Vendor Telegram 1 + 2 Process Data	Vendor 1 + 2 PD
111	Vendor Telegram 1 + 3 Process Data	Vendor 1 + 3 PD
112	Vendor Telegram 1 + 4 Process Data	Vendor 1 + 4 PD
113	Vendor Telegram 1 + 5 Process Data	Vendor 1 + 5 PD
114	Vendor Telegram 1 + 6 Process Data	Vendor 1 + 6 PD
115	Vendor Telegram 1 + 7 Process Data	Vendor 1 + 7 PD
116	Vendor Telegram 1 + 8 Process Data	Vendor 1 + 8 PD
140	Vendor Telegram 1 + 12 Process Data *	Vendor 1 + 12 PD
141	Vendor Telegram 1 + 16 Process Data *	Vendor 1 + 16 PD

* 12 and 16 process data items will be available in future releases. At the moment, the incoming process data 9-16 is not handled. Outgoing process data 9-16 is zero.

Table 42. Vendor telegram 1 setpoint and actual data

Bytes	Setpoint	Actual value
1...2	FB FIXED CW	8.3.3.5
3...4	FB SPEED REF	8.3.3.9
5...6	PDI1	8.3.3.11
7...8	PDI2	
...	...	
19...20	PDI8	
21...22	PDI9*	
...	...	
35...36	PDI16*	

* Not used / zero if not supported (see chapter 6.2)

Control and Status Word monitoring values

When using this telegram, monitoring values contains values as shown in table below.

Table 43. Control and Status Word monitoring values

Name	Value
Drive CW	FBFixedControlWord
Drive SW	FBFixedStatusWord
Protocol CW	FBFixedControlWord
Protocol SW	FBFixedStatusWord

8.3.2.3 VACON®-specific Telegram 2 and its variants

These telegrams (Table 44) use VACON®-defined control word, status word, speed setpoint value and speed actual value to directly access the AC drive application. The difference to vendor telegram 1 types are the added general control and status words.

NOTE! This telegram type is not supported when using VACON® 100 family AC drives. 32-bit process data support for VACON® 100 family AC drives is added in future release.

Table 44. Vendor telegram 2 and variants

Telegram No.	Telegram	Abbreviation
117	Vendor Telegram 2	Vendor 2
118	Vendor Telegram 2 + 1 Process Data	Vendor 2 + 1 PD
119	Vendor Telegram 2 + 2 Process Data	Vendor 2 + 2 PD
120	Vendor Telegram 2 + 3 Process Data	Vendor 2 + 3 PD
121	Vendor Telegram 2 + 4 Process Data	Vendor 2 + 4 PD
122	Vendor Telegram 2 + 5 Process Data	Vendor 2 + 5 PD
123	Vendor Telegram 2 + 6 Process Data	Vendor 2 + 6 PD
124	Vendor Telegram 2 + 7 Process Data	Vendor 2 + 7 PD
125	Vendor Telegram 2 + 8 Process Data	Vendor 2+ 8 PD
142	Vendor Telegram 2 + 12 Process Data *	Vendor 2 + 12 PD
143	Vendor Telegram 2 + 16 Process Data *	Vendor 2 + 16 PD

* 12 and 16 process data items will be available in future releases. At the moment, the incoming process data 9-16 is not handled. Outgoing process data 9-16 is zero.

When using these telegrams, the process data fields are communicated as 32-bit values, but when using VACON® NX or VACON® 20 family AC drives, the data is actually 16-bits and transferred in the lower bytes.

Table 45. Process data item definition when using Vendor telegram 2

Bytes	VACON® NX	VACON® 20	VACON® 100 family
1...2	16-bit Process data	16-bit Process data	Future release: 32-bit process data
3...4	Not used	Not used	

Table 46. Vendor telegram 2 setpoint and actual data

Bytes	Setpoint		Actual value	
1...2	FB FIXED CW	8.3.3.5	FB FIXED SW	8.3.3.6
3...4	FB GENERAL CW	8.3.3.7	FB GENERAL SW	8.3.3.8
5...6	FB SPEED REF	8.3.3.9	FB SPEED ACT	8.3.3.10

Table 46. Vendor telegram 2 setpoint and actual data

Bytes	Setpoint		Actual value	
7...10	PDI1*	8.3.3.11	PD01*	8.3.3.11
11...14	PDI2*		PD02*	
...	
35...38	PDI8*		PD08*	
39...42	PDI9**		PD09**	
...	
67...70	PDI16**		PD016**	

* 32-bits. See Table 45

** See above Not used / zero if not supported (see chapter 6.2)

Control and Status Word monitoring values

When using this telegram, monitoring values contains values as shown in table below.

Table 47. Control and Status Word monitoring values

Name	Value
Drive CW	FBFixedControlWord
Drive SW	FBFixedStatusWord
Protocol CW	FBGeneralControlWord
Protocol SW	FBGeneralStatusWord

8.3.2.4 VACON®-specific Telegram 3 and its variants

These telegrams (Table 48) use PROFIdrive-defined control word, status word, speed setpoint value and speed actual value with VACON® general control and status words for added functionality.

NOTE! This telegram type is not supported when using VACON® 100 family AC drives. 32-bit process data support for VACON® 100 family AC drives is added in future release.

NOTE! When board is connected to VACON® 100 family AC drive and its mode parameter is set to "NX Mode", the option board will use FBSpeedReference/FBSpeedActual instead of NSOLL_A/ NIST_A as backward compatibility for OPTCP option board.

Table 48. Vendor telegram 3 and variants

Telegram No.	Telegram	Abbreviation
126	Vendor Telegram 3	Vendor 3
127	Vendor Telegram 3 + 1 Process Data	Vendor 3 + 1 PD
128	Vendor Telegram 3 + 2 Process Data	Vendor 3 + 2 PD
129	Vendor Telegram 3 + 3 Process Data	Vendor 3 + 3 PD
130	Vendor Telegram 3 + 4 Process Data	Vendor 3 + 4 PD
131	Vendor Telegram 3 + 5 Process Data	Vendor 3 + 5 PD
132	Vendor Telegram 3 + 6 Process Data	Vendor 3 + 6 PD
133	Vendor Telegram 3 + 7 Process Data	Vendor 3 + 7 PD
134	Vendor Telegram 3 + 8 Process Data	Vendor 3 + 8 PD
144	Vendor Telegram 3 + 12 Process Data *	Vendor 3 + 12 PD
145	Vendor Telegram 3 + 16 Process Data *	Vendor 3 + 16 PD

* 12 and 16 process data items will be available in future releases. At the moment, the incoming process data 9-16 is not handled. Outgoing process data 9-16 is zero.

When using these telegrams, the process data fields are communicated as 32-bit values, but when using VACON[®] NX or VACON[®] 20 family AC drives, the data is actually 16-bits and transferred in the lower bytes.

Table 49. Process data item definition when using Vendor telegram 3

Bytes	VACON [®] NX	VACON [®] 20 / 20 X	VACON [®] 100 family
1...2	16-bit Process data	16-bit Process data	Future release: 32-bit process data
3...4	Not used	Not used	

Table 50. Vendor telegram 3 setpoint and actual data

Bytes	Setpoint	Actual value		
1...2	STW1	8.3.3.1	ZSW1	8.3.3.2
3...4	FB GENERAL CW	8.3.3.7	FB GENERAL SW	8.3.3.8
5...6	NSOLL_A	8.3.3.3	NIST_A	8.3.3.4
7...10	PDI1*	8.3.3.11	PD01*	8.3.3.11
11...14	PDI2*		PD02*	
...	
35...38	PDI8*		PD08*	
39...42	PDI9**		PD09**	
...	
67...70	PDI16**		PD016**	

* 32-bits. See Table 49

** See above Not used / zero if not supported (see chapter 6.2)

Control and Status Word monitoring values

When using this telegram, monitoring values contains values as shown in table below.

Table 51. Control and Status Word monitoring values

Name	Value
Drive CW	FBFixedControlWord
Drive SW	FBFixedStatusWord
Protocol CW	STW1
Protocol SW	ZSW1

8.3.2.5 VACON®-specific Telegram 4 and its variants

Use these telegram types (Table 52) as a replacement for the OPT-CP option board, when using "Bypass mode".

You can also use these telegram types when the PROFIdrive functionality is required and a VACON® application with PROFIdrive state machine is activated (e.g. VACON® NX Advanced Application).

Table 52. Vendor telegram 4 and variants

Telegram No.	Telegram	Abbreviation
135	Vendor Telegram 4	Vendor 4
136	Vendor Telegram 4 + 4 Process Data	Vendor 4 + 4 PD
137	Vendor Telegram 4 + 8 Process Data	Vendor 4 + 8 PD
146	Vendor Telegram 4 + 12 Process Data	Vendor 4 + 12 PD
147	Vendor Telegram 4 + 16 Process Data	Vendor 4 + 16 PD

Table 53. Vendor telegram 4 setpoint and actual data

Bytes	Setpoint	Actual value		
1...2	FB FIXED CW	8.3.3.5	FB GENERAL SW	8.3.3.8
3...4	FB SPEED REF	8.3.3.9	FB SPEED ACT	8.3.3.10
5...6	PDI1	8.3.3.11	PDO1	8.3.3.11
7...8	PDI2		PDO2	
...	
19...20	PDI8		PDO8	
21...22	PDI9*		PDO9*	
...	
35...36	PDI16*		PDO16*	

* Not used / zero if not supported (see chapter 6.2)

Control and Status Word monitoring values

When using this telegram, monitoring values contains values as shown in table below.

Table 54. Control and Status Word monitoring values

Name	Value
Drive CW	FBFixedControlWord
Drive SW	FBFixedStatusWord
Protocol CW	FBFixedControlWord
Protocol SW	FBGeneralStatusWord

8.3.3 TELEGRAM BUILDING BLOCKS

8.3.3.1 PROFIdrive Control Word 1 (STW1)

The following table lists the assignments of bits in the control word 1.

Table 55. Overview of the assignments of bits of the control word 1

Bit	Significance	
	Bit value is 1	Bit value is 0
0	ON	OFF
1	No Coast Stop (no OFF2)	Coast Stop (OFF2)
2	No Quick Stop (no OFF3)	Quick Stop (OFF3)
3	Enable Operation	Disable Operation
4	Enable Ramp Generator	Reset Ramp Generator
5	Unfreeze Ramp Generator	Freeze Ramp Generator
6	Enable Setpoint	Disable Set Point
7	Fault Acknowledge (0 -> 1)	
8	Not used	
9	Not used	
10*	Control by PLC	No control by PLC
11	Device-specific	Device-specific
12-15	Device-specific	Device-specific

*Bits in a control word do not have any effect unless bit 10 is enabled.

Bit 0: Switching ON / OFF

This bit is used in combination with other bits to enable operation of the drive. When this bit is set to 0 during operation, the drive performs a ramp stop.

Bit 1: Coast stop command

This bit is used to request a coast stop to be executed. When it is set to 0 during operation, the drive performs a coast stop.

Bit 2: Quick stop command

This bit is used to request a quick stop to be executed. When it is set to 0 during operation, the drive quickly ramps down to zero speed and stops.

Bit 3: Enabling of operation

This bit is used in combination with other bits to enable operation of the drive. When it is set to 0 during operation, the drive performs a coast stop.

Bit 4: Enabling of ramp generator

This bit is used in combination with other bits to enable operation of the drive. When it is set to 0 during operation, the drive quickly decelerates to zero speed.

Bit 5: Freezing of ramp generator

This bit can be used to freeze the setpoint value used by the drive. The value is frozen if this bit is set to 0. If the bit is 1, the setpoint value provided by the master is continuously updated.

Bit 6: Enabling of setpoint value

This bit can be used to disable the fieldbus setpoint value. If this bit is set to 0, the option board ignores the setpoint value by the master and instead uses a setpoint value of 0. During operation, if this bit is set to 0, the drive decelerates to a standstill.

Bit 7: Fault acknowledge

This bit is used to acknowledge faults in the drive. When a rising edge (0 -> 1) is seen in this bit by the option board, it requests the drive to acknowledge present faults. The functionality of this bit is rising-edge sensitive only.

Bit 10: Control by PLC

This bit is used by the master to indicate that it is in control of the slave and that the commands sent via fieldbus are valid.

During operation, this bit must be 1. If the drive is not operating and this bit is 0, the drive cannot be started.

If the drive is operating, and this bit becomes 0, the option board freezes the process data provided to the drive, and sets its state to FAULT. The drive reaction to this fieldbus fault depends on the drive parameterization.

8.3.3.2 PROFIdrive Status Word 1 (ZSW1)

The table below lists the assignments of the status word 1.

Table 56. Overview of the assignments of bits of the status word 1

Bit	Significance	
	Bit value is 1	Bit value is 0
0	Ready to Switch On	Not Ready To Switch On
1	Ready To Operate	Not Ready To Operate
2	Operation Enabled (drive follows set-point)	Operation Disabled
3	Fault Present	No Fault
4	Coast Stop Not Activated (No OFF2)	Coast Stop Activated (OFF2)
5	Quick Stop Not Activated (No OFF3)	Quick Stop Activated (OFF3)
6	Switching On Inhibited	Switching On Not Inhibited
7	Warning Present	No Warning
8	Speed Error Within Tolerance Range	Speed Error Out Of Tolerance Range
9	Control by PLC Requested	No Control by PLC Requested

Bit	Significance	
	Bit value is 1	Bit value is 0
10	f Or n Reached Or Exceeded	f Or n Not Reached
11	Device-specific	Device-specific
12	Drive running	Drive stopped
13	Drive is ready	Drive is not ready
14-15	Device-specific	Device-specific

Bit 0: Readiness to switch on

This bit indicates whether the drive is ready to switch on the power electronics. When the bit has the value 0, the drive is not ready to switch on the power electronics. When the bit has the value 1, the drive is ready to switch on the power electronics.

Bit 1: Readiness to operate

This bit indicates whether the drive is ready to begin operation. When the bit has the value 0, the power electronics is switched off and the drive is unable to begin operation. When the bit has the value 1, the power electronics is switched on and the drive can begin operation if requested by the master.

Bit 2: State of operation

This bit indicates whether the drive is operating or not. When the bit has the value 0, the drive is not operating. When the bit has the value 1, the drive is operating.

Bit 3: Presence of fault

This bit indicates the presence of unacknowledged faults in the drive. When the bit has the value 0, no unacknowledged faults are present in the drive. When the bit has the value 1, at least one unacknowledged fault is present in the drive.

Bit 4: Coast stop activated

This bit indicates whether a coast stop command is active or not. When the bit has the value 0, a coast stop command is active. When the bit has the value 1, no coast stop command is active.

Bit 5: Quick stop activated

This bit indicates whether a quick stop command is active or not. When the bit has the value 0, a quick stop command is active. When the bit has the value 1, no quick stop command is active.

Bit 6: Switching on inhibition

This bit indicates whether the power electronics may be switched on or not. When the bit has the value 0, the power electronics may be switched on. When the bit has the value 1, the power electronics are prevented from switching on.

Bit 7: Presence of warning

This bit indicates the presence of warning/alarm information in the drive. When the bit has the value 0, no warning is present. When the bit has the value 1, a warning is present.

Bit 8: Running at setpoint

This bit indicates whether the drive is operating and the actual speed value matches the setpoint value. When the bit has the value 0, the actual speed value does not match the setpoint value. When the bit has the value 1, the actual speed value matches the setpoint value.

Bit 9: Request control by master

This bit indicates whether the fieldbus master should take control of the drive. When this bit has the value 0, the master does not take control of the drive. When this bit has the value 1, the master is requested to take control of the drive.

In OPTe9, this bit depends on the configuration for the drive control place. If the control place is assigned to fieldbus, the bit has the value 1. If the control place is elsewhere, the bit has the value 0.

Bit 10: Setpoint reached or exceeded

This bit indicates whether the setpoint value has been reached or exceeded. When this bit has the value 0, the setpoint value has not been reached or exceeded. When this bit has the value 1, the setpoint value has been reached or exceeded.

Bit 12: Drive running

This bit indicates drive state. If bit is 1, the motor is running. If bit is zero, the motor has been stopped.

Bit 13: Drive ready

This bit indicates drive state. If bit is 1, the drive is ready for transition to running state.

8.3.3.3 PROFIdrive speed setpoint value NSOLL_A

Normalised 16-bit speed setpoint (containing a sign bit and a 15-bit integer).

Table 57.

Setpoint value	Speed	Direction of rotation	Description of command
0xC000 (-16384d)	-100.00%	REVERSE	Full speed in REVERSE direction
0x0000 (0d)	0.00%	N/A	Minimum speed
0x4000 (16384d)	+100.00%	FORWARD	Full speed in FORWARD direction

PNU 10111 shows the "100%" speed as RPM.

NOTE! When the board is connected to VACON® 100 family AC drive and its mode parameter is set to "NX Mode", the option board will use FBSpeedReference instead of NSOLL_A as backward compatibility for OPTCP option board. This means that the value range is 0d-10000d. See chapter 8.3.3.9 for details.

8.3.3.4 PROFIdrive speed actual value NIST_A

Normalised 16-bit speed actual value (containing a sign bit and a 15-bit integer).

Table 58.

Setpoint value	Speed	Direction of rotation	Description of command
0xC000 (-16384d)	-100.00%	REVERSE	Full speed in REVERSE direction
0x0000 (0d)	0.00%	N/A	Standstill
0x4000 (16384d)	+100.00%	Status Word dependent	Full speed in FORWARD direction

PNU 10111 shows the "100%" speed as RPM.

NOTE! When the board is connected to VACON® 100 family AC drive and its mode parameter is set to "NX Mode", the option board will use FBSpeedActual instead of NIST_A as backward compatibility for OPTCP option board. This means that value range is 0d-10000d. See chapter 8.3.3.10 for details.

8.3.3.5 VACON® FBFixedControlWord

For details about vendor control word, see Chapter 12 "APPENDIX 2 - CONTROL AND STATUS WORD"

8.3.3.6 VACON® FBFixedStatusWord

For details about vendor status word, see Chapter 12 "APPENDIX 2 - CONTROL AND STATUS WORD".

8.3.3.7 VACON® FBGeneralControlWord

FB General Control Word is 16-bit in length and it is completely application-dependent.

8.3.3.8 VACON® FBGeneralStatusWord

FB General Status Word is 16-bit in length and it is completely application-dependent.

8.3.3.9 VACON® FBSpeedReference

The FBSpeedReference value is unsigned in the range 0...10000d (0...2710h). The value 0 corresponds to MinimumFrequency and the value 10000d corresponds to MaximumFrequency. Requested direction is indicated using bit 1 in the FBFixedControlWord. The scale of the value is 0.01%.

8.3.3.10 VACON® FBSpeedActual

The FBActualSpeed value is unsigned in the range 0...10000d (0...2710h). The value 0 corresponds to MinimumFrequency and the value 10000d corresponds to MaximumFrequency. The direction is indicated using bit 2 in the FBFixedStatusWord. The scale of the value is 0.01%.

8.3.3.11 VACON® Process Data

The Process Data variables are vendor-specific variables that can be communicated to and from the AC drive. There can be up to eight Process Data variables communicated in a single telegram. Values sent from the option board to the master are called ProcessDataOut variables, while the values sent from the master to the option board are called ProcessDataIn variables. The contents of the ProcessDataOut variables can be parameterised in the AC drive using a feature known as Fieldbus Process Data mapping. See the AC drive's Application Manual for further details.

8.3.4 QUICK SETUP

By following these instructions, you can easily and fast set up your Profinet IO for use:

NOTE! Example is using telegram ST1 with STW1/ZSW1 and NSOLL_A / NIST_A.

In the AC drive application: Choose Fieldbus as the active control place (see the AC drive's User Manual).

In the Master software:

1. Set the Control Word value to 0hex.
2. Set the Control Word value to 47Ehex.
3. Set the Control Word value to 47Fhex.
4. AC drive status is RUN.
5. Set the Reference value to '2000Hex' (=50.00%).
6. Actual speed is 2000Hex (25.00 Hz if MinFreq is 0.00 Hz and MaxFreq is 50.00 Hz)
7. Set the Control Word value to 47Ehex.
8. AC drive status is STOP.

8.4 PROFIDRIVE IO PARAMETERS**8.4.1 PARAMETERS OF THE PROFIDRIVE**

The table below lists the basic PROFIdrive parameters (continued on the next page).

Table 59. PROFIdrive basic parameters

PNU	Significance	Data type	Explanation
915	Selection switch for DO IO Data in the setpoint telegram	Array[n] Unsigned16	Describes the data in the setpoint telegram. The parameter is an array of signals' numbers that creates the setpoint telegram.
916	Selection switch for DO IO Data in the actual value telegram	Array[n] Unsigned16	Describes the data in the actual value telegram. The parameter is an array of signals' numbers that creates the actual value telegram.
922	Telegram selection	Unsigned16	Currently selected standard telegram is read. It returns for example 1 for ST1. See chapter 8.3.1 for possible values.
923	List of all parameters for signals	Array[n] Unsigned16	The parameter is an array. The index of the array indicates for a signal number and its value for corresponding parameter number. Not supported standard signals, those in range 1-99, have values set to 0. Gaps between the device-specific signals are also filled with 0. Refer to Table 62.
930	Operating mode	Unsigned16	1 = Speed control mode
944	Fault message counter	Unsigned16	The fault message counter is incremented each time that the fault buffer changes. This means that it is guaranteed that the fault buffer is consistently read-out. Without this parameter, it is not guaranteed that the fault buffer does not change while reading-out.

Table 59. PROFIdrive basic parameters

PNU	Significance	Data type	Explanation
947	Fault number	Array[n] Unsigned16	The parameter is an array of 8 elements. The first element indicates an active unacknowledged fault. The following elements contain acknowledged ones. The latest acknowledged fault number is at index 1 and oldest one at index 7.
964	Drive Unit Identification	Array[n] Unsigned16	An array is structured in the following way (index meaning): 0 = Manufacturer code (0x01BA) 1 = Drive Unit Type (0x0002): 1 = VACON® NX series, 2 = VACON® 100 series, 3 = VACON® 20 series 2 = Software version - XXYYd (XX - major revision, YY - minor revision) 3 = Firmware date (year) - YYYYd 4 = Firmware date (day/month) - DDMMd 5 = Number of Drive Objects (0x0001)
965	Profile identification number	OctetString2	Two bytes to identify the profile that is used. 1st - profile number; PROFIdrive (3d) 2nd - profile version number; 4.1 (41d)
975	DO identification	Array[n] Unsigned16	An array is structured in the following way (index meaning): 0 = Manufacturer code (0x01BA) 1 = Drive Unit Type (0x0003) 2 = Software version - XXYYd (XX - major revision, YY - minor revision) 3 = Firmware date (year) - YYYYd 4 = Firmware date (day/month) - DDMMd 5 = Drive Object Type Class - Axis (0x0001) 6 = Drive Object Sub-class 1 - Only Application Class 1 (0x0001) 7 = Drive Object ID (value 1)
980 - 989	Number list of defined parameter	Array[n] Unsigned16	980: This is a list of the parameter numbers of all the implemented parameters. The list does not contain the number 980-989. Parameters are listed in the ascending (growing) order. The end-of-list is indicated by the value 0. 981-989: Not used. Length of each is 1 and value is 0, indicating an empty list.

8.4.1.1 PROFIdrive parameters for PROFINET IO communication interface

The table below lists the PROFINET IO communication interface parameters.

Table 60. PROFIdrive parameters

PNU	Significance	Data type	Explanation
61000	NameOfStation	Octet-String[240] with-out null termination	Name of Station for the PROFINET IO Network Interface, which is related to this Drive Unit.
61001	IpOfStation	Unsigned32	IP Address of the Station for the PROFINET IO Network Interface.
61002	MacOfStation	OctetString [6]	MAC Address of the Station for the PROFINET IO Network Interface
61003	DefaultGatewayOfStation	Unsigned32	Default Gateway for the Station for the PROFINET IO Network Interface.
61004	SubnetMaskOfStation	Unsigned32	Subnet Mask of the Station for the PROFINET IO Network Interface.

8.4.2 VENDOR-SPECIFIC PROFIDRIVE PARAMETERS

The table below lists vendor-specific PROFIdrive parameters.

Table 61. PROFIdrive drive-specific parameters

PNU	Significance	Data type	Explanation
9900	Test parameter (non-array)	Unsigned16	For testing purposes. Does not affect the operation of the drive.
9901	Test parameter (array)	Array[n] Unsigned16	An array of 16 elements. Used only for testing purposes. Does not affect the operation of the drive.
10001	Drive parameter access	Array[n] Special case, data type depends from the sub index	A parameter used to access parameters from the drive application. You can do this by putting the desired drive parameter ID into the sub index field of the parameter request. See chapter 8.4.8
10100	Profile control word (STW1)	Unsigned16	PROFIdrive 4.1 control word (STW1).
10101	Profile speed setpoint value (NSOLL_A)	Integer16	PROFIdrive 4.1 speed setpoint value (NSOLL_A).
10102	Profile status word (ZSW1)	Unsigned16	PROFIdrive 4.1 status word (ZSW1).
10103	Profile speed actual value (NIST_A)	Integer16	PROFIdrive 4.1 speed actual value (NIST_A).
10109	VACON® 16-bit Process Data In	Array[n] Unsigned16	An array of 16 elements. From PDI1 (index 0) to PDI16 (index 15).
10110	VACON® 16-bit Process Data Out	Array[n] Unsigned16	An array of 16 elements. From PDO1 (index 0) to PDO16 (index 15).
10111	Speed physical reference parameter	Unsigned16	The parameter describes how many RPM is meant by 100% in the PROFIdrive 4.1 speed setpoint and actual value fields.
10112	VACON® Fixed Control Word	Unsigned16	Fixed control word.

Table 61. PROFIdrive drive-specific parameters

PNU	Significance	Data type	Explanation
10113	VACON [®] Fixed Status Word	Unsigned16	Fixed status word.
10114	VACON [®] Speed reference	Unsigned16	Speed reference.
10115	VACON [®] Speed Actual value	Unsigned16	Actual speed value.
10118	Clear VACON [®] fault history	Unsigned16	To clear the fault history, write a value to the parameter.
10119	Read VACON [®] fault history	Array[n] Unsigned16	An array of 40 elements consisting of VACON [®] fault history fault codes.
10120	VACON [®] General Control word	Unsigned16	General control word.
10121	VACON [®] General Status word	Unsigned16	General status word.
10122	VACON [®] 32-bit Process Data In	Array[n] Unsigned32	An array of 16 elements. From PDI1 (index 0) to PDI16 (index 15).
10123	VACON [®] 32-bit Process Data Out	Array[n] Unsigned32	An array of 16 elements. From PDO1 (index 0) to PDO16 (index 15).
10124	Drive operation time counter	Unsigned32	Drive operation time in seconds as 32 bit unsigned integer.
10125	Drive operation time trip counter	Unsigned32	Drive operation time trip counter in seconds as 32 bit unsigned integer. Writing zero will reset trip counter.
10126	Drive energy counter	Float32	Drive energy counter in KWh as 32 bit float (IEEE 754).
10127	Drive energy trip counter	Float32	Drive energy trip counter in KWh as 32 bit float (IEEE 754). Writing zero will reset trip counter.

8.4.3 PROFIDRIVE SIGNAL NUMBERS

The table below lists the PROFIdrive signal numbers (continued on the next page).

Table 62. PROFIdrive signal numbers

Signal no.	Signal name	PNU	PNU name
1	Control word 1	10100	PROFIdrive control word (STW1)
2	Status word 1	10102	PROFIdrive status word (ZSW1)
5	Speed setpoint A	10101	PROFIdrive speed setpoint value (NSOLL_A)
6	Speed actual value A	10103	PROFIdrive speed actual value (NIST_A)
51	Output current	10104	Always returns zero.
52	Active current (torque proportional)	10105	Always returns zero.
54	Active power	10106	Always returns zero.
57	Speed actual value A	10107	Always returns zero.
58	Drive status/fault word	10108	Always returns zero.
100	VACON [®] PDO1	10110	VACON [®] 16-bit Process Data Out
101	VACON [®] PDO2	10110	VACON [®] 16-bit Process Data Out
102	VACON [®] PDO3	10110	VACON [®] 16-bit Process Data Out

Table 62. PROFIdrive signal numbers

Signal no.	Signal name	PNU	PNU name
103	VACON [®] PDO4	10110	VACON [®] 16-bit Process Data Out
104	VACON [®] PDO5	10110	VACON [®] 16-bit Process Data Out
105	VACON [®] PDO6	10110	VACON [®] 16-bit Process Data Out
106	VACON [®] PDO7	10110	VACON [®] 16-bit Process Data Out
107	VACON [®] PDO8	10110	VACON [®] 16-bit Process Data Out
110	VACON [®] PDI1	10109	VACON [®] 16-bit Process Data In
111	VACON [®] PDI2	10109	VACON [®] 16-bit Process Data In
112	VACON [®] PDI3	10109	VACON [®] 16-bit Process Data In
113	VACON [®] PDI4	10109	VACON [®] 16-bit Process Data In
114	VACON [®] PDI5	10109	VACON [®] 16-bit Process Data In
115	VACON [®] PDI6	10109	VACON [®] 16-bit Process Data In
116	VACON [®] PDI7	10109	VACON [®] 16-bit Process Data In
117	VACON [®] PDI8	10109	VACON [®] 16-bit Process Data In
118	VACON [®] fixed control word	10112	VACON [®] Fixed Control Word
119	VACON [®] fixed status word	10113	VACON [®] Fixed Status Word
120	VACON [®] fixed reference value	10114	VACON [®] Speed reference
121	VACON [®] fixed actual value	10115	VACON [®] Speed Actual value
122*	VACON [®] general control word	10120	VACON [®] General Control word
123*	VACON [®] general status word	10121	VACON [®] General Status word
124*	VACON [®] DW PDO1	10123	VACON [®] 32-bit Process Data Out
125*	VACON [®] DW PDO2	10123	VACON [®] 32-bit Process Data Out
126*	VACON [®] DW PDO3	10123	VACON [®] 32-bit Process Data Out
127*	VACON [®] DW PDO4	10123	VACON [®] 32-bit Process Data Out
128*	VACON [®] DW PDO5	10123	VACON [®] 32-bit Process Data Out
129*	VACON [®] DW PDO6	10123	VACON [®] 32-bit Process Data Out
130*	VACON [®] DW PDO7	10123	VACON [®] 32-bit Process Data Out
131*	VACON [®] DW PDO8	10123	VACON [®] 32-bit Process Data Out
132*	VACON [®] DW PDI1	10123	VACON [®] 32-bit Process Data Out
133*	VACON [®] DW PDI2	10123	VACON [®] 32-bit Process Data Out
134*	VACON [®] DW PDI3	10122	VACON [®] 32-bit Process Data In
135*	VACON [®] DW PDI4	10122	VACON [®] 32-bit Process Data In
136*	VACON [®] DW PDI5	10122	VACON [®] 32-bit Process Data In
137*	VACON [®] DW PDI6	10122	VACON [®] 32-bit Process Data In
138*	VACON [®] DW PDI7	10122	VACON [®] 32-bit Process Data In

Table 62. PROFIdrive signal numbers

Signal no.	Signal name	PNU	PNU name
139*	VACON® DW PDI8	10122	VACON® 32-bit Process Data In
140	VACON® PDO9	10110	VACON® 16-bit Process Data Out
141	VACON® PDO10		
142	VACON® PDO11		
143	VACON® PDO12		
144	VACON® PDO13		
145	VACON® PDO14		
146	VACON® PDO15		
147	VACON® PDO16		
148	VACON® PDI9	10109	VACON® 16-bit Process Data In
149	VACON® PDI10		
150	VACON® PDI11		
151	VACON® PDI12		
152	VACON® PDI13		
153	VACON® PDI14		
154	VACON® PDI15		
155	VACON® PDI16		
156	VACON® DW PDO9*	10123	VACON® 32-bit Process Data Out
157	VACON® DW PDO10*		
158	VACON® DW PDO11*		
159	VACON® DW PDO12*		
160	VACON® DW PDO13*		
161	VACON® DW PDO14*		
162	VACON® DW PDO15*		
163	VACON® DW PDO16*		
164	VACON® DW PDI9*	10122	VACON® 32-bit Process Data In
165	VACON® DW PDI10*		
166	VACON® DW PDI11*		
167	VACON® DW PDI12*		
168	VACON® DW PDI13*		
169	VACON® DW PDI14*		
170	VACON® DW PDI15*		
171	VACON® DW PDI16*		

* 32 bit data not supported in current version. See chapter 5.

8.4.4 USER SPECIFIC RECORD DATA

For easy access to drive parameters and monitoring values, the OPTE9 maps the PROFINET user specific record indexes 0x0000 - 0x7FFF directly into the application IDs of the drive based on the IEC61131 standard. Both read and write access is supported.

NOTE! The response data is in raw format. See application manual for available IDs, amount of decimals and the unit used for the parameters.

IDs can be read/written as VACON® NX scaled values in all AC drives, or, in VACON® 100 family AC drives, also as actual raw value.

Table 63. Application ID access settings

Slot	Subslot	Description	Note
1	1	Access IDs as VACON® NX scaled values	
	2	Access IDs as VACON® 100 family actual data type	Only available in VACON® 100 family AC drives

In the examples below, the following index values are used:

- 102 = Maximum frequency (Hz)
- 600 = Motor control mode

Table 64. Example 1: Reading values from different AC drives

AC drive	Read command			Response		
	Slot	Subslot	Index	Hex	Dec	Actual value
Any	1	1	102	13 88	5000	50.00 Hz
			600	00 01	1	1 = OL Speed
VACON® 100 family	1	2	102	00 07 A1 20	500000	50.0000 Hz
			600	00 00 00 01	1	1 = OL Speed

Table 65. Example 2: Writing values for different AC drives

AC drive	Write command					Actual value
	Slot	Subslot	Index	Length	Value (Hex)	
Any	1	1	102	2	11 94	45.00 Hz
			600	2	00 00	0 = OL Frequency
VACON® 100 family	1	2	102	4	00 06 DD D0	45.0000 Hz
			600	4	00 00 00 00	0 = OL Frequency

8.4.5 BASE MODE PARAMETER ACCESS MODEL

The PROFdrive parameters are accessed according to the model presented below:

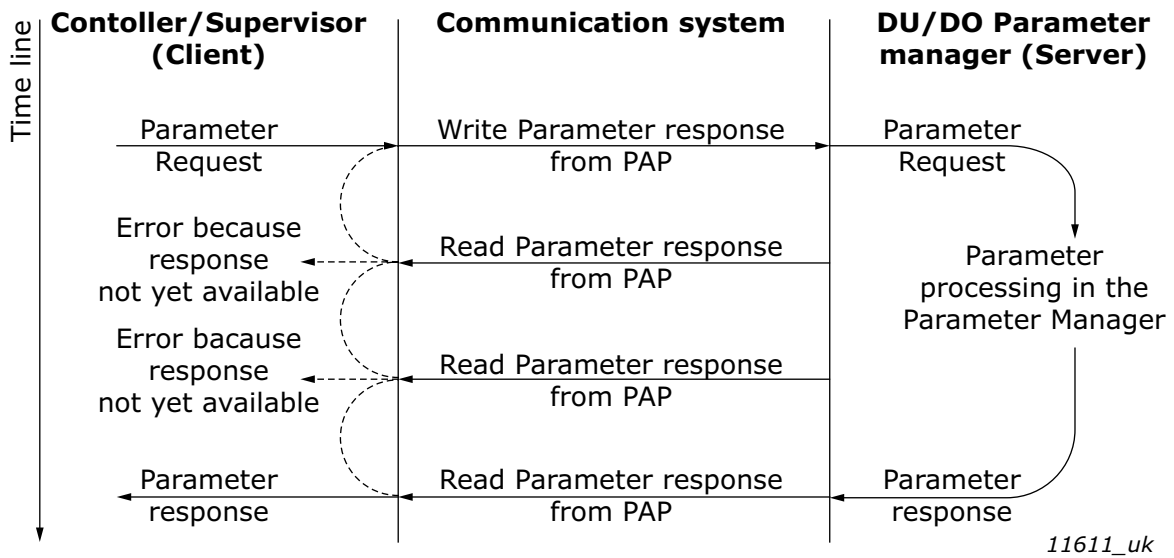

Figure 37. PROFdrive parameter access model

Both indexes can be used to access PROFdrive parameters. There is no difference in operation between them with current implementation.

Table 66. Parameter access services

Parameter access service	Index
Base Mode Parameter - Local	0xB02E
Base Mode Parameter - Global	0xB02F

The structure of parameter requests is described in the table below:

Table 67. Parameter request

Block definition	Byte n+1	Byte n	n
Request Header	Request Reference	Request ID	0
	Axis-No. / DO-ID	No. of Parameters = n	2
1st Parameter Address	Attribute	No. of Elements	4
	Parameter Number (PNU)		
	Subindex		
nth Parameter Address	...		4 + 6 x (n - 1)
1st Parameter Value(s) (only for request "Change parameter")	Format	No. of Values	4 + 6 x n
	Values		
	...		
nth Parameter Values	...		
			4 + 6 x n + ... + (For-mat_n x Qty_n)

The structure of parameter responses is described in the table below:

Table 68. Parameter response

Block definition	Byte n+1	Byte n	n
Response header	Request Ref. mirrored	Response ID	0
	Axis-No. / DO-ID mirrored	No. of Parameters = n	2
1st Parameter Value(s) (only for request "Request")	Format	No. of Values	4
	Values or Error Values		
	...		
nth Parameter Values	...		
			4 + ... + (Format_n x Qty_n)

The table below contains descriptions of parameters.

Table 69. Parameter description

Sub-index	Field name	Data type	Description
1	Identifier (ID)	Unsigned16	A bitmask with information about the parameter characteristics.
2	Number of array elements	Unsigned16	For array parameters, the number of elements in the array.
3	Standardisation factor	FloatingPoint (IEEE 754)	If the information represented by the parameter can be converted into a standardised form, this field contains a factor for this conversion.
4	Variable attribute	Array of two Unsigned8	Contains two index numbers for describing the parameter information.
5	Reserved	Array of four Unsigned8	Reserved, always 0.
6	Name	ASCII string, 16 characters	Symbolic name of the parameter.
7	Low limit	Array of four Unsigned8	Limit for valid values of the parameter.
8	High limit	Array of four Unsigned8	Limit for valid values of the parameter.
9	Reserved	Array of two Unsigned8	Reserved, always 0.
10	ID extension	Unsigned16	Not used, always 0.
11	Normalisation reference parameter	Unsigned16	Parameter number, the value of which is used as normalisation reference for the parameter whose description this is.
12	Normalisation field	Unsigned16	Contains information about normalisation of this parameter.

8.4.5.1 Parameter requests

There are two types of parameter requests in PROFIdrive:

- Read requests for reading parameters from the device
- Change requests for writing parameters to the device

Each parameter request consists of three elements:

- Request header
- Parameter address
- Parameter value (only in Change requests)

Request header	Parameter address(es)	Parameter value(s)
----------------	-----------------------	--------------------

8.4.5.2 Request header

The request header consists of 4 fields, each one octet in size.

Table 70. Request header

Octet number	Field name	Description	Allowed values
1	Request Reference	Unique number for each request/response pair. This value is changed by the master for each new request. It is mirrored by the slave in the response.	A bitmask with information about the parameter characteristics.
2	Request ID	Defines the type of request.	Use 0x01 for Read requests. Use 0x02 for Change requests. Other values are not allowed.
3	Axis Number	Not used, should be set to 1.	Use 1 for OPTE9 PROFINET IO. Other values should not be used.
4	Requested number of parameters	The number of parameters affected by the request.	Values 1 to 39 are allowed. The value 0 is not allowed. Values 40 to 255 are not allowed.

8.4.5.3 Parameter address

The parameter address consists of 4 fields, totaling six octets in size.

Table 71. Parameter address

Octet number	Field name	Description	Allowed values
1	Attribute	Describes which part of a parameter should be accessed.	Use 0x10 for reading/writing the value of a parameter. Use 0x20 for reading the description of a parameter. Use 0x30 for reading the text of a parameter (not supported). Other values should not be used.
2	Number of elements	Specifies the number of elements that are addressed in an array.	Values 0 and 1 are allowed for non-array parameters. Values 1 to 234 are allowed for array parameters. Other values should not be used.
3...4	Parameter number	The number of the parameter to be addressed.	Allowed values are those of supported parameters, see chapter 8.4.6.2.
5...6	Subindex	Defines the first array element of the parameter to be accessed.	Values 0 to 65535 are allowed. Other values are not allowed.

The "Parameter number" and "Subindex" fields are two-octet fields, while the "Attribute" and "No. of elements" fields are one-octet fields.

8.4.5.4 Parameter value

The parameter value field is included only in Change requests (not in Read requests). The parameter value field consists of a two-octet parameter value header followed by a list of values. Depending on the format of the parameter, the octet size of a single value is one, two or four octets. The total size of the parameter value field thus depends on the format and number of values in the message.

Table 72. Parameter value

Octet number	Field name	Description	Allowed values
1	Format	Describes the data type of the parameter.	Use 0x41 for Byte. Use 0x42 for Word. Use 0x43 for Double Word. Value 0x44 is used for Error. Other values should not be used.
2	Number of values	Defines the number of values in the parameter value field.	Values 0 to 234 are possible. Subject to limitations as described below.
3...	Value	The value of the parameter.	Values 0 to 65535 are allowed. Other values are not allowed.

The number of values which can be transmitted in one frame has been limited to 39.

8.4.6 PARAMETER RESPONSES

There are two types of parameter responses in PROFIdrive:

- Write response (response to a Write request)
- Read response (response to a Read request)

A read response consists of two elements:

- Response header
- Parameter value(s) (depending on the request type)

Response header	Parameter value(s)
-----------------	--------------------

8.4.6.1 Error response

If an error occurred in the Parameter Access, the response provided by the slave is an error response. An error response contains 4 octets as described below.

Table 73. Error response

Octet number	Field name	Description	Allowed values
1	Function Number	Operation number.	The slave returns 0xDE to indicate an error read response. The slave returns 0xDF to indicate an error write response. Other values are not used in the Parameter Access.
2	Error Decode	Defines how the error information in the following two fields should be decoded.	Always 128 in PROFIdrive. Other values are not used in the Parameter Access.

Octet number	Field name	Description	Allowed values
3	Error Code 1	High 4 bits indicate error class, 4 lower bits indicate error code.	See Chapter 8.4.6.3 "PROFIdrive Parameter Access errors"
4	Error Code 2	Application-specific.	Always 0 in PROFIdrive.

8.4.6.2 PROFIdrive 4.1 error classes and codes

The table below lists PROFIdrive profile 4.1 error classes and codes.

Table 74. PROFIdrive 4.1 error classes and codes

Error class	Error codes	PROFIdrive meaning
0x0...0x9 = reserved (not used)		
0xA = application	0x0 = read error 0x1 = write error 0x2 = module failure 0x3...0x7 = reserved (not used) 0x8 = version conflict 0x9 = feature not supported 0xA...0xF = user-specific (not used)	
	0xB = access	0xB0 = parameter requests are not supported.
0xB = access	0x0 = invalid index	
	0x1 = write length error 0x2 = invalid slot 0x3 = type conflict 0x4 = invalid area	
	0x5 = state conflict	0xB5 = parameter access is temporarily not possible due to internal processing status.
	0x6 = access denied	
	0x7 = invalid range	0xB7 = Write request with error in the parameter request header.
	0x8 = invalid parameter 0x9 = invalid type	
	0xA...0xF = user-specific (not used)	
0xC = resource	0x0 = read constraint conflict 0x1 = write constraint conflict 0x2 = resource busy 0x3 = resource unavailable 0x4...0x7 = reserved (not used) 0x8...0xF = user-specific (not used)	
	0xD...0xF = user-specific (not used)	

8.4.6.3 PROFIdrive Parameter Access errors

In addition to the error indications in the error response field, details about the error are provided in the parameter value field. The third octet in the parameter value is set to 0x00 and the fourth octet is assigned the error number, as described in Table 75.

Table 75. PROFIdrive parameter access errors

Error number	Meaning	When used
0x00	Impermissible parameter number	Access to unavailable parameter.
0x01	Parameter value cannot be changed	Change request to a read-only parameter.
0x02	0x0 = invalid index	0xB0 = parameter requests are not supported.
0x03	Invalid subindex	Access to an unavailable subindex of an array parameter.
0x04	Non-array parameter	Attempt to access subindex of a non-array parameter.
0x05	Incorrect data type	Change request containing invalid data type for the accessed parameter.
0x06	Setting not permitted (may only be reset)	Change request to a non-zero value, where this is not allowed.
0x07	Description element cannot be changed	Change request to a read-only parameter description element.
0x08	Reserved (not used)	
0x09	No description data available	Access to unavailable parameter description.
0x0A	Reserved (not used)	
0x0B	No operation priority	Change request without access rights to perform the change.
0x0C...0x0E	Reserved (not used)	
0x0F	No text array available	Access to unavailable parameter text array.
0x10	Reserved (not used)	
0x11	Request cannot be executed	Access is temporarily not possible due to unspecified reasons.
0x12...0x13	Reserved (not used)	
0x14	Value impermissible	Change request with a value within the allowed range, but is otherwise not permissible.
0x15	Response too long	The length of the response exceeds the maximum transmittable length.
0x16	Impermissible parameter address	Error in the parameter address field.
0x17	Illegal format	Illegal format was provided in write request.
0x18	Number of values are not consistent	The number of values in the write request does not match the number of values in the parameter.
0x19	Axis non-existent	Access to non-existent axis number

Table 75. PROFIdrive parameter access errors

Error number	Meaning	When used
0x20	Parameter text cannot be changed	Change request to unavailable parameter text.
0x21	Invalid request ID	If a parameter request does not have the request ID 01h or 02h, this error code is returned.
0x22...0x64	Reserved (not used)	
0x65	Invalid request reference	Unallowed value for request reference.
0x66	Invalid request ID	Unallowed value in request ID (neither Request Parameter nor Change Parameter).
0x67	Reserved (not used)	
0x68	Invalid number of parameters	Invalid number of parameters in request (0 or greater than 39).
0x69	Invalid attribute	Invalid attribute specified in request.
0x6A	Reserved (not used)	
0x6B	Request is too short	Not enough parameter value data was transmitted in a Change request. Alternatively, the request did not contain a complete parameter address.
0x6C	Parameter not found.	Parameter was not found or error occurred while accessing it.
0x6D	Invalid change request.	Issue with request was found and request was not handled.
0x6E	General error	General error occurred.
0x6F...0xFF	Reserved (not used)	

8.4.6.4 Response header

The response header consists of 4 fields, each one is octet in size.

Table 76. Response header

Octet number	Field name	Description	Allowed values
1	Request Reference	Unique number for each request/response pair.	Mirrored by the slave.
2	Response ID	Defines the type of response. An error in the execution of a request is indicated by setting bit 7 in this field.	Uses 0x01 for successful request parameter operation. Uses 0x02 for successful change parameter operation. Uses 0x80 to indicate that an invalid request ID was received. Uses 0x81 for unsuccessful request parameter operation. Uses 0x82 for unsuccessful change parameter operation. Other values are not used.
3	Axis Number	Not used, should be set to 1.	Mirrored by the slave.
4	Requested number of parameters	The number of parameters affected by the request.	Number of parameters in the response. Mirrored from the request.

8.4.6.5 Parameter values

Parameter values are included in the response only if the request was of "Request parameter" type. For details on the contents of this field, see Parameter value on Chapter 8.4.5.4 "Parameter value"

8.4.7 DRIVE PARAMETER ACCESS USING APPLICATION ID

It is possible to read and write drive parameters using the application ID number using the PNU 10001. The targeted application ID is put into the subindex field.

8.4.8 PARAMETER CHANNEL EXAMPLES

The parameter channel operations follow the same process every time. Figure 38 shows a successful operation. It is important to wait long enough after "Write request" before doing "Read request". If read operation is done too soon, drive has not finished processing the operation and will respond with error (see Figure 2 PROFIdrive parameter access model). Then the PLC must try to read again after some time. Time between write and read requests depends on the operation. Figure 4 shows what the parameter request looks like in Wireshark and Figure 5 shows how "PROFINET Master Simulator" tool is used for requesting the value.

Parameter operations sent to the AC drive must be directed to: slot 0, subslot 1 and to index 0xB02E

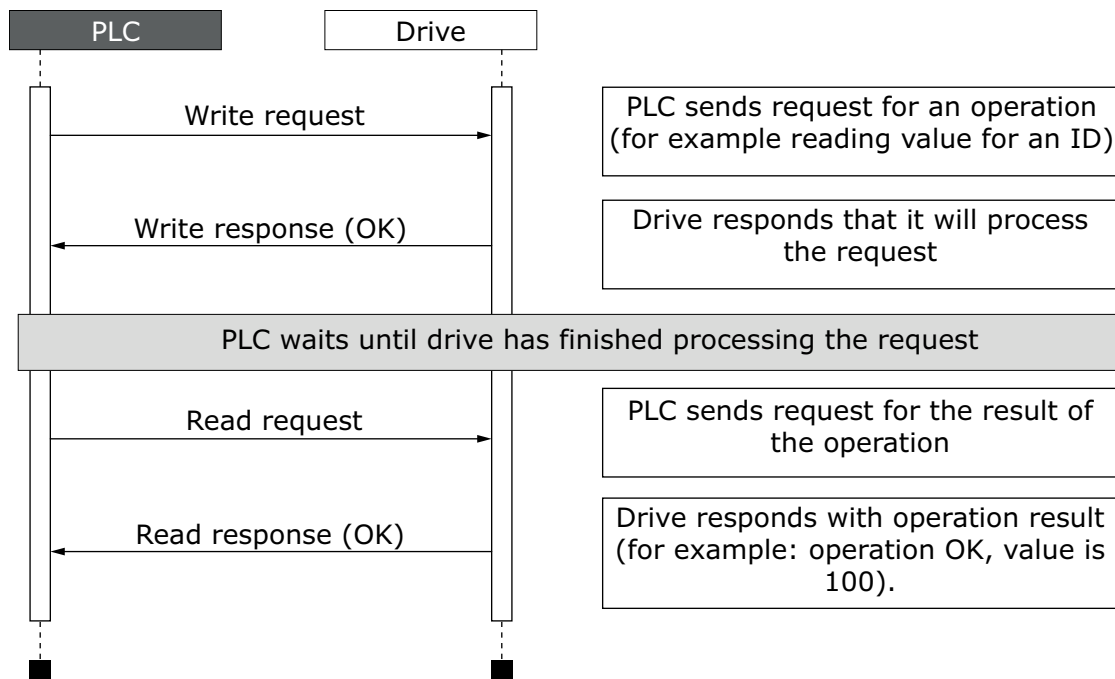

11753_uk

Figure 38. Successful parameter channel operation

No.	Time	Source	Destination	Protocol	Length	Info
506	4.989523	192.168.0.200	192.168.0.50	PNIO-CM	216	PROFIdrive Write Request, ReqRef:0x03, Read DO:1, P10001[103]
509	4.997681	192.168.0.50	192.168.0.200	PNIO-CM	206	Write response, OK, IODWriteResHeader, Api:0x0, Slot:0x0/0x1, J
512	5.039513	192.168.0.200	192.168.0.50	PNIO-CM	206	Read request, IODReadReqHeader, Api:0x0, Slot:0x0/0x1, Index:PF
513	5.045738	192.168.0.50	192.168.0.200	PNIO-CM	214	PROFIdrive Read Response, ReqRef:0x03, RspId:Positive read resp

11754_00

Figure 39. Wireshark capture of requesting value for ID103

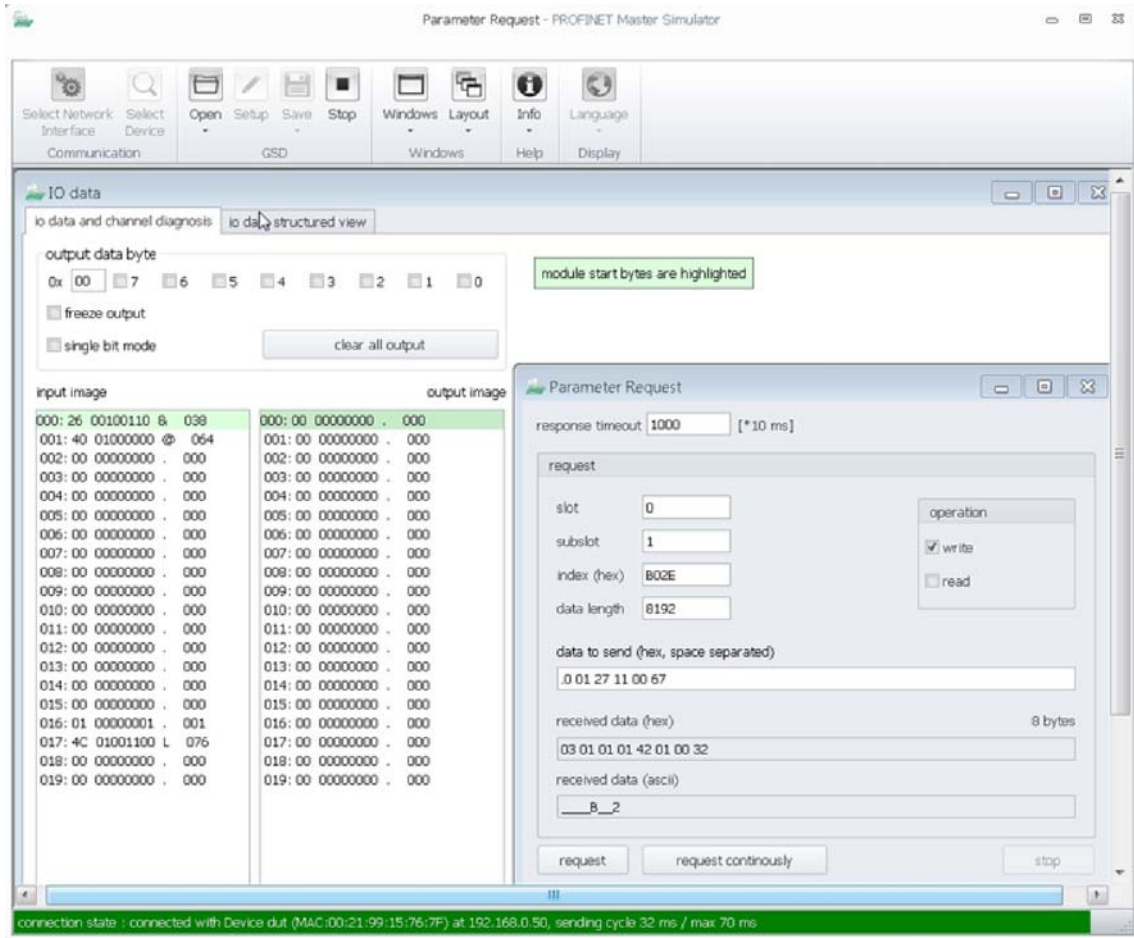

11755_00

Figure 40. Screen capture from “PROFINET Master Simulator” requesting value for ID103.

8.4.8.1 Request first element of PNU964 value

The following information is used for this request:

Table 77. Request first element of PNU964

Field	Contents
Request reference	0x01
Request ID	0x01 = Request parameter
Axis Number	0x01
No. of Parameters	0x01
Attribute	0x10 = Value
No. of elements	0x01
Parameter Number	0x03C4 (964d)
Subindex	0x0000 (0d)

The following table contains messages sent during requesting value for PNU964.

Table 78. Messages sent and received during requesting value for PNU964

Message	Operation	Data	
1	Write request	Request header	0x01 0x01 0x01 0x01
		Parameter address	0x10 0x01 0x03 0xC4 0x00 0x00
2	Write request response from AC drive to PLC		
-	PLC waits until AC drive has finished processing the requested operation		
3	PLC sends read request		
4	Read request response	Response header	0x01 0x01 0x01 0x01
		Parameter value	0x42 0x01 0x01 0xBA

The parameter value reveals that the format of the value is "Word" (0x42), there is one value in the response (0x01) and the actual value is 0x01BA.

8.4.8.2 Request all elements of PNU964 value

The following information is used for this request.

Table 79. Request all elements of PNU 964

Field	Contents
Request reference	0x02
Request ID	0x01 = Request parameter
Axis Number	0x01
No. of Parameters	0x01
Attribute	0x10 = Value
No. of elements	0x06
Parameter Number	0x03C4 (964d)
Subindex	0x0000 (0d)

The following table contains messages sent during requesting all values for PNU964.

Table 80. Messages sent and received during requesting all values for PNU964

Message	Operation	Data	
1	Write request	Request header	0x02 0x01 0x01 0x01
		Parameter address	0x10 0x06 0x03 0xC4 0x00 0x00
2	Write request response from AC drive to PLC		
-	PLC waits until AC drive has finished processing the requested operation		
3	PLC sends read request		
4	Read request response	Response header	0x02 0x01 0x01 0x01
		Parameter value	0x42 0x06 0x01 0xBA 0x00 0x02 0x00 0x64 0x07 0xDE 0x00 0x65 0x00 0x01

The returned value consists of six words (0x42 means Word, 0x06 is the number of values returned), and the values are 0x01BA, 0x0002, 0x0064, 0x07DE, 0x0065, and 0x0001. Thus the following information can be determined about the device:

- Manufacturer code is 0x01BA
- Drive Unit type is 0x0002
- Software version is 1.0 (0x0064 = 0100d)
- Firmware date (year) is 2014 (0x07DE)
- Firmware date (day/month) is 1/1 (0x0065 = 101d)
- The device contains one axis

8.4.8.3 Requesting the value of drive parameter ID 103

The following information is used for this request:

Table 81. Request value of parameter ID 103

Field	Contents
Request reference	0x03
Request ID	0x01 = Request parameter
Axis Number	0x01
No. of Parameters	0x01
Attribute	0x10 = Value
No. of elements	0x01
Parameter Number	0x2711 (10001d)
Subindex	0x0067 (103d)

Following table contains messages sent during requesting value for ID 103.

Table 82. Messages sent and received during requesting value for ID 103

Message	Operation	Data	
1	Write request	Request header	0x03 0x01 0x01 0x01
		Parameter address	0x10 0x01 0x27 0x11 0x00 0x67
2	Write request response from AC drive to PLC		
-	PLC waits until AC drive has finished processing the requested operation		
3	PLC sends read request		
4	Read request response	Response header	0x03 0x01 0x01 0x01
		Parameter value	0x42 0x01 0x00 0x0A

The parameter value reveals that the format of the value is "Word" (0x42), there is one value in the response (0x01) and the actual value is 0x000A. Because this value was read from the AC drive application, the Drive Application Manual contains details on how to interpret the value. In this example, the Acceleration time would be one second.

8.4.8.4 *Changing the value of drive parameter ID 103 (successful)*

The following information is used for this request:

Table 83. Request to write the value of parameter ID 103

Field	Contents
Request reference	0x04
Request ID	0x02 = Write parameter
Axis Number	0x01
No. of Parameters	0x01
Attribute	0x10 = Value
No. of elements	0x01
Parameter Number	0x2711 (10001d)
Subindex	0x0067 (103d)
Parameter datatype	0x42 = WORD
Number of parameters	0x01
Value: HI byte	0x00
Value: LOW byte	0x28

Following table contains messages sent during writing value to ID 103.

Table 84. Messages sent and received during writing value to ID 103

Message	Operation	Data	
1	Write request	Request header	0x04 0x02 0x01 0x01
		Parameter address	0x10 0x01 0x27 0x11 0x00 0x67
		Parameter value	0x42 0x01 0x00 0x28
2	Write request response from AC drive to PLC		
-	PLC waits until AC drive has finished processing the requested operation		
3	PLC sends read request		
4	Read request response	Response header 0x04 0x02 0x01 0x01	

Answer indicates a successful operation.

8.4.8.5 Changing the value of drive parameter ID 103 (unsuccessful)

This example shows behaviour in case where ID modification fails. PLC writes request to change ID 103 value to 0d (Acceleration Time = 0.0s, not allowed)

Table 85. Request to write the value of parameter ID 103

Field	Contents
Request reference	0x05
Request ID	0x02 = Write parameter
Axis Number	0x01
No. of Parameters	0x01
Attribute	0x10 = Value
No. of elements	0x01
Parameter Number	0x2711 (10001d)
Subindex	0x0067 (103d)
Parameter datatype	0x42 = WORD
Number of parameters	0x01
Value: HI byte	0x00
Value: LOW byte	0x00

Following table contains messages sent during unsuccessful writing value to ID 103.

Table 86. Messages sent and received during unsuccessful writing value to ID 103

Message	Operation	Data	
1	Write request	Request header	0x05 0x02 0x01 0x01
		Parameter address	0x10 0x01 0x27 0x11 0x00 0x67
		Parameter value	0x42 0x01 0x00 0x00
2	Write request response from AC drive to PLC		
-	PLC waits until AC drive has finished processing the requested operation		
3	PLC sends read request		
4	Read request response	Response header	0x05 0x82 0x01 0x01
		Parameter value	0x44 0x01 0x00 0x02

Answer indicates an unsuccessful operation with error "Low or high limit exceeded".

8.4.8.6 Changing multiple parameter values (ID 103 and ID 104)

The following information is used for this request:

Table 87. Request to write the value of parameter ID 103 and ID 104

Field	Contents
Request reference	0x06
Request ID	0x02 = Write parameter
Axis Number	0x01
No. of Parameters	0x02 (two parameters, ID 103 and ID104)
Attribute	0x10 = Value

Table 87. Request to write the value of parameter ID 103 and ID 104

Field	Contents
No. of elements	0x01
Parameter Number	0x2711 (10001d)
Subindex	0x0067 (103d, ID 103)
Attribute	0x10 = Value
No. of elements	0x01
Parameter Number	0x2711 (10001d)
Subindex	0x0068 (104d, ID 104)
Parameter datatype	0x42 = WORD
Number of parameters	0x01
Value	0x0028 (Value for ID 103)
Parameter datatype	0x42 = WORD
Number of parameters	0x01
Value	0x0028 (Value for ID 104)

Following table contains messages sent during writing values to ID 103 and ID 104.

Table 88. Messages sent and received during writing value to ID 103

Message	Operation	Data	
1	Write request	Request header	0x06 0x02 0x01 0x02
		Parameter address	0x10 0x01 0x27 0x11 0x00 0x67 0x10 0x01 0x27 0x11 0x00 0x68
		Parameter value	0x42 0x01 0x00 0x28 0x42 0x01 0x00 0x28
2	Write request response from AC drive to PLC		
-	PLC waits until AC drive has finished processing the requested operation		
3	PLC sends read request		
4	Read request response	Response header	0x06 0x02 0x01 0x01

Answer indicates a successful operation.

8.5 PROFINET IO COMMUNICATIONS AND CONNECTION TIMEOUT

The PROFINET IO declares a watchdog time within which both master and slave must send IO back to each other. This watchdog time is a factor of the communication cycle time and is set by the master. Minimum cycle time for OPTE9 PROFINET IO is 1 millisecond.

In case of normal communication mode, 4 ms is the fastest recommended cycle time for PROFINET IO. Faster cycle times (1 ms and 2 ms) are recommended in Fast Mode. See chapter 6.2 for more details.

The PROFINET IO also declares the process data validity on a submodule level. This validity is informed between provider and consumer with the IOPS (Input/Output Provider State) byte. If the incoming data validity is other than GOOD, OPTE9 ignores this data completely and uses the latest valid data.

When the data state toggles from GOOD to BAD or an IO message is not received within the watchdog time, the timeout setting value is activated and a fault is created after it elapses. This means that the panel parameter "Communication timeout" (refer to chapter 6.1.6) is used as an additional timeout value. The same behaviour applies if a connection is closed or the cable disconnects (link loss). See Figure 41 for the timeout fault logic.

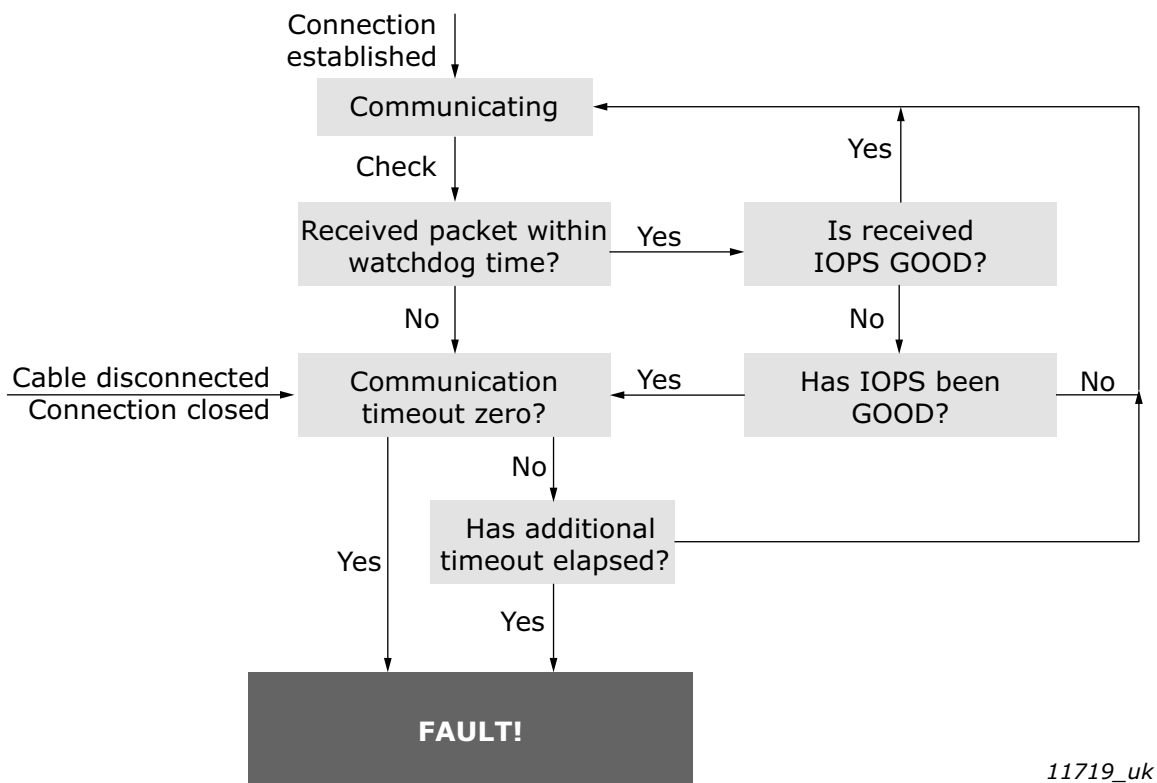

Figure 41. PROFINET IO communication and timeout fault

The OPTE9 will set its data status to GOOD as soon as it receives valid data from the AC drive. Unless the communication to the AC drive breaks, the data remains GOOD. The IOCS are GOOD as soon as the option board is able to receive and handle IO data.

8.6 ALARM SYSTEM

The OPTE9 implements PROFINET IO alarm system where VACON® faults and alarms are seen on bus as PROFINET IO alarms. The alarms use module specific channel diagnostic and extended channel diagnostic data. The GSDML file contains description and help texts for the alarms. Texts are in English and Finnish. Automation systems can use these texts to display helpful diagnostics to end users in case of faults.

The figures below show how Siemens TIA portal displays the diagnostics.

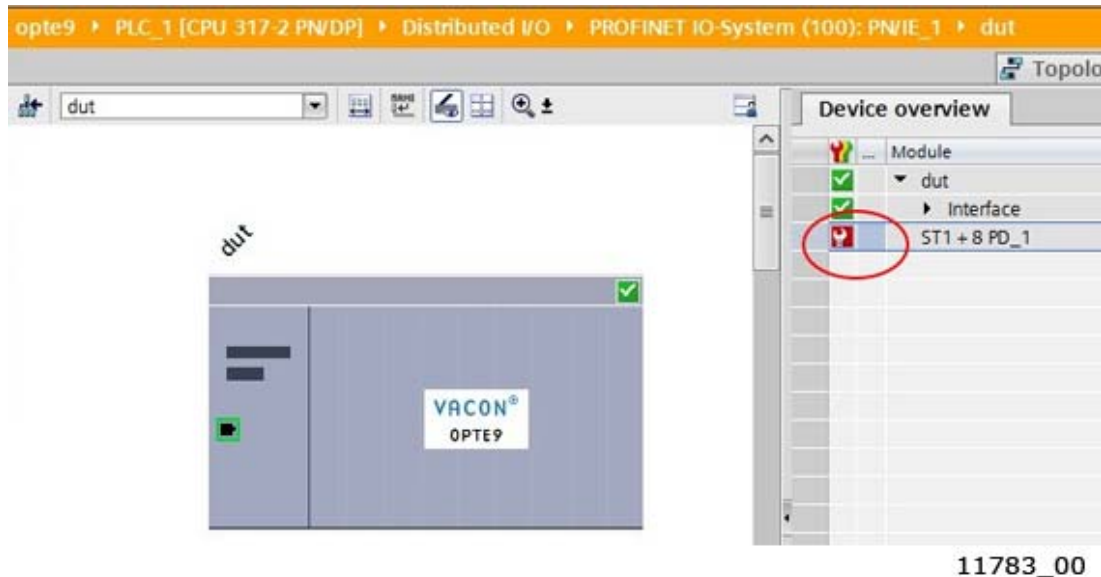

Figure 42. Siemens TIA portal - Alarm indicator

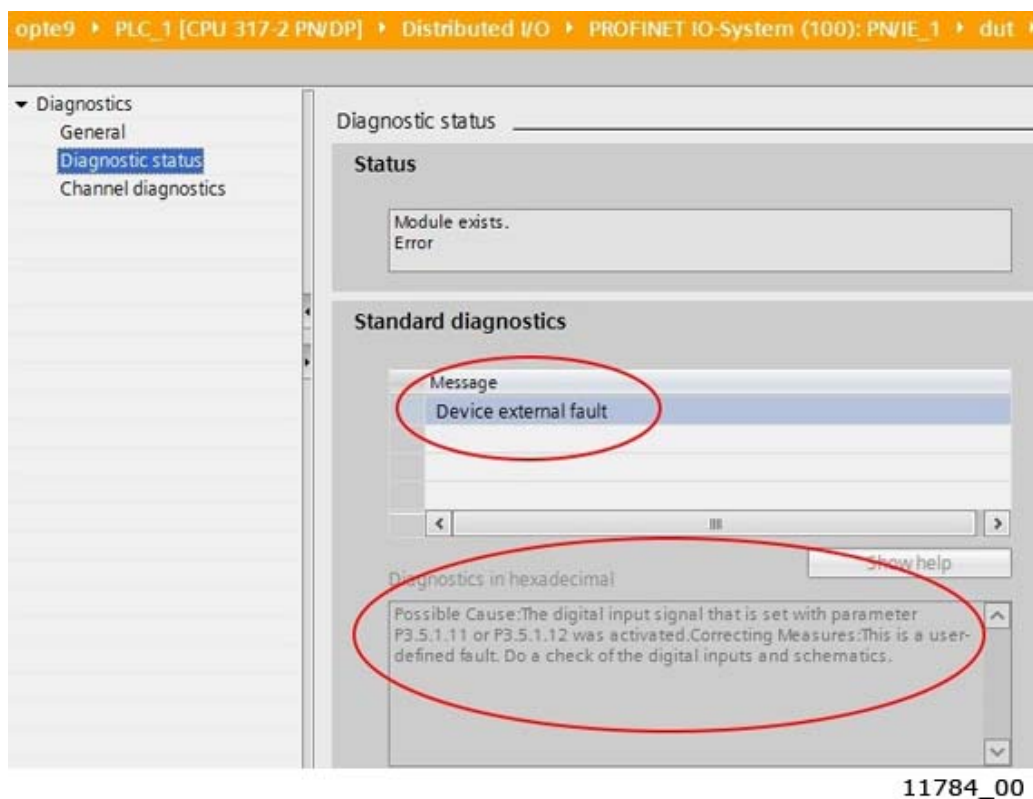

Figure 43. Siemens TIA portal - Alarm description and help text

The VACON® data (faults, alarms, infos) mapped to PROFINET IO alarms is slightly different based on the used AC drive:

Table 89. VACON® data in different AC drives

AC drive type	Fault	Alarm	Info
VACON® NXP/NXS	Yes	Yes	No
VACON® 100 family	Yes	Yes, from version: <ul style="list-style-type: none"> • FW0072V026 (INDUSTRIAL) • FW0159V017 (FLOW) 	No
VACON® 20 family	Yes	No	No

VACON® faults are mapped to PROFINET IO alarms according to the following table:

Table 90.

AC drive Type	Channel Error	Extended Channel Error
VACON® NXP/NXS	1000 + Fault code	Subcode
VACON® 100 family	2000 + Fault code	Fault Id
VACON® 20 family	3000 + Fault code	Subcode

For example, the fieldbus timeout fault (Fault code 53) in different drives have the following channel error codes:

Table 91.

AC drive Type	Channel Error	Extended Channel Error
VACON® NXP/NXS	1053	1
VACON® 100 family	2053	1053
VACON® 20 family	3053	0

The customized applications might use customized fault IDs which are not described in the GSDML file. The PROFINET IO alarms are however generated for all faults that have a fault code between 0 and 1000.

9. ETHERNET/IP

9.1 GENERAL INFORMATION

The EtherNet/IP™ is an industrial Ethernet network solution available for manufacturing automation. The CIP™ (Common Industrial Protocol) encompasses a comprehensive suite of messages and services for a variety of manufacturing automation applications, including control, safety, synchronization, motion, configuration and information. The CIP provides users with a unified communication architecture throughout the manufacturing enterprise.

More information on the EtherNet/IP can be found at www.odva.org.

9.1.1 OVERVIEW

The EtherNet/IP (Ethernet/Industrial Protocol) is a communication system suitable for use in industrial environments. The EtherNet/IP allows industrial devices to exchange time-critical application information. These devices include simple I/O devices such as sensors/actuators, as well as complex control devices such as robots, programmable logic controllers, welders, and process controllers.

The EtherNet/IP uses CIP (Control and Information Protocol), the common network, transport and application layers also shared by ControlNet and EtherNet/IP. The EtherNet/IP then makes use of standard Ethernet and TCP/IP technology to transport CIP communications packets. The result is a common, open application layer on top of open and highly popular Ethernet and TCP/IP protocols.

The EtherNet/IP Messaging Forms:

- Unconnected Messaging is used for connection establishment and for infrequent, low priority messages.
- Connected Messaging utilizes resources which are dedicated in advance to a particular purpose such as real-time I/O data transfer. EtherNet/IP Messaging Connections.
- Explicit Messaging Connections are general purpose point-to-point connections. Messages are sent through the TCP protocol.
- Implicit (I/O Data) Connections are established to move application specific I/O Data at regular intervals. They are often set up as one-to-many relationships in order to take full advantage of the producer-consumer multicast model. Implicit messages are sent through the UDP protocol.

9.1.2 AC/DC DRIVE PROFILE

OPTE9 implements the CIP AC/DC drive profile.

In order to provide interoperability between devices from different manufacturers, there must be a defined "standard" in which those devices:

- exhibit the same behaviour
- produce and/or consume the same basic set of I/O data
- contain the same basic set of configurable attributes. The formal definition of this information is known as a device profile.

9.1.3 EDS FILE

You can provide configuration support for your device by using a specially formatted ASCII file, referred to as the EDS (Electronic Data Sheet). An EDS provides information about the device configuration.

The information in an EDS allows configuration tools to provide informative screens that guide a user through the steps necessary to configure a device. An EDS provides all of the information necessary to access and alter the configurable parameters of a device.

OPTE9 has multiple EDS files, at least one per AC drive type. You can download the AC drive specific EDS from Danfoss website (<http://drives.danfoss.com>). See also Chapter 6.1.9 "EIP Product code offset".

9.1.4 LED FUNCTIONALITY

The OPTE9 LEDs follow the CIP standard when the EtherNet/IP is set as the active protocol. The LEDs on the option board are not labeled as the CIP defines. The LED labels are described in table below.







Table 92. OPTE9 EtherNet/IP LED Definitions

LED label	Description	CIP definition
RN	Network Status Indicator	NS
ER	Not used	-
BS	Module Status indicator	MS

9.1.4.1 Module Status LED

The Module status LED is labeled on the board as "BS". It shows the status of the module, that is, if a fault has occurred or if the module has been configured. The MS LED functionality is described in the table below.







Table 93. EtherNet/IP Module Status LED functionality

LEDs	State	Summary	Requirement
	Steady Off	No power	If no power is supplied to the device, the module status indicator is steady off.
	Steady Green	Device operational	If the device is operating correctly, the module status indicator is steady green.
	Flashing Green	Standby	If the device has not been configured, the module status indicator is flashing green.
	Flashing Red	Minor fault	If the device has detected a recoverable minor fault, the module status indicator is flashing red.
	Steady Red	Major fault	If the device has detected a non-recoverable major fault, the module status indicator is steady red.
	Flashing Green / Red	Self-test	While the device is performing its power up testing.

9.1.4.2 Network Status LED

The Network status LED is labeled on the board as "RN". It shows the connectivity status of the device, that is, if there is a connection to the device, or the IP settings status. The NS LED functionality is described in the table below.

Table 94. EtherNet/IP Network status LED functionality

LEDs	State	Summary	Requirement
	Steady Off	Not powered, no IP address	The device is powered off, or is powered on but with no IP address configured (Interface Configuration attribute of the TCP/IP Interface Object).
	Flashing Green	No connections	An IP address is configured, but no CIP connections are established, and an Exclusive Owner connection has not timed out.
	Steady Green	Connected	At least one CIP connection (any transport class) is established, and an Exclusive Owner connection) has not timed out.
	Flashing Red	Connection timeout	An Exclusive Owner connection for which this device is the target has timed out. The LED returns to steady green only when all timed out Exclusive Owner connections are re-established. Timeout of connections other than Exclusive Owner connections will not cause the indicator to flash red.
	Steady Red	Duplicate IP	The device has detected that its IP address is already in use by another device in the network.
	Flashing Green / Red	Self-test	While the device is performing its power up testing

9.1.5 EXPLICIT MESSAGING

Explicit Messaging is used in commissioning and parameterizing of the EtherNet/IP board.

The explicit messages provide multipurpose, point-to-point communication paths between two devices. They provide the typical request/response-oriented network communication used to perform node configuration and problem diagnosis. The explicit messages typically use low priority identifiers and contain the specific meaning of the message right in the data field. This includes the service to be performed and the specific object attribute address.

NOTE! If Class 1 connection (cyclic data) has been established, the Explicit Messages should not be used to control the Output Data. However this restriction does not apply for the IO Data reading.

9.1.5.1 List of data types

The elementary data types in CIP are (among others):

Table 95. EtherNet/IP datatypes

Name	Description	Bit size	Range	
			Minimum	Maximum
BOOL	Boolean	8	0 = FALSE	1 = TRUE
SINT	Short Integer	8	-128	127
INT	Integer	16	-32768	32767
DINT	Double Integer	32	-2^{31}	$2^{31} - 1$
LINT	Long Integer	64	-2^{63}	$2^{63} - 1$
USINT	Unsigned Short Integer	8	0	255
UINT	Unsigned Integer	16	0	65535
UDINT	Unsigned Double Integer	32	0	$2^{32} - 1$
ULINT	Unsigned Long Integer	64	0	$2^{64} - 1$
REAL	Floating Point	32	See IEEE 754	
LREAL	Long Floating Point	64	See IEEE 754	
STRING *	Character string (1 octet per char.)	N		
SHORT_STRING *	Character string (1 octet per char., 1 octet length indicator)	N+1		
BYTE	Bit string (8 bits)	8		
WORD	Bit string (16 bits)	16		
DWORD	Bit string (32 bits)	32		
LWORD	Bit string (64 bits)	64		

* ISO/IEC-8859-1 encoding.

9.1.5.2 General CIP error codes

The table below contains the error codes used by the OPTE9 EtherNet/IP implementation.

Table 96. General CIP error codes

Code	Status name	Description
0	Success	Service was successfully performed by the object specified.
1	Connection failure	A connection related service failed along the connection path.
2	Resource unavailable	Resources needed for the object to perform the requested service were unavailable.
3	Invalid parameter value	See Status Code 0x20, which is the preferred value to use for this condition.
4	Path segment error	The path segment identifier or the segment syntax was not understood by the processing node.
5	Path destination unknown	The path is referencing an object class, instance or structure element that is not known or is not contained in the processing node.
6	Partial transfer	Only part of the expected data was transferred.
8	Service not supported	The requested service was not implemented or was not defined for this Object Class/Instance.
9	Invalid attribute value	Invalid attribute data detected.
12 _d / 0C _h	Object state conflict	The object cannot perform the requested service in its current mode/state.
14 _d / 0E _h	Attribute not settable	A request to modify a non-modifiable attribute was received.
15 _d / 0F _h	Privilege violation	A permission/privilege check failed.
16 _d / 10 _h	Device state conflict	The device's current mode/state prohibits the execution of the requested service.
17 _d / 11 _h	Reply data too large	The data to be transmitted in the response buffer is larger than the allocated response buffer.
19 _d / 13 _h	Not enough data	The service did not supply enough data to perform the specified operation.
20 _d / 14 _h	Attribute not supported	The attribute specified in the request is not supported.
21 _d / 15 _h	Too much data	The service supplied more data than was expected.
30 _d / 1E _h	Embedded service error	An embedded service resulted in an error.
31 _d / 1F _h	Vendor specific error	A vendor specific error has been encountered. The Additional Code Field of the Error Response defines the particular error encountered.
32 _d / 20 _h	Invalid parameter	A parameter associated with the request was invalid.
38 _d / 26 _h	Path Size Invalid	The size of the path which was sent with the Service Request is either not large enough to allow the Request to be routed to an object or too much routing data was included.
29 _h	Member not settable	A request to modify a non-modifiable member was received.
46 _d / 2E _h	Service Not Supported for Specified Path	The object supports the service, but not for the designated application path (e.g. attribute).

9.1.5.3 Connection Manager Object Error codes

These are the extended status codes used when the general status code is 1.

Table 97. Connection Manager Object Error codes

Extended Status	Descriptions
256 _d / 100 _h	Connection in use or duplicate forward open
259 _d / 103 _h	Transport class and trigger combination not supported
262 _d / 106 _h	Ownership conflict
263 _d / 107 _h	Target connection not found
264 _d / 108 _h	Invalid network connection parameter
265 _d / 109 _h	Invalid connection size
272 _d / 110 _h	Target for connection not configured
273 _d / 111 _h	RPI not supported
274 _d / 112 _h	RPI value(s) not acceptable
275 _d / 113 _h	Out of connections
276 _d / 114 _h	Vendor id or product code mismatch
277 _d / 115 _h	Product type mismatch
278 _d / 116 _h	Revision mismatch
279 _d / 117 _h	Invalid produced or consumed application path
280 _d / 118 _h	Invalid or inconsistent configuration application path
281 _d / 119 _h	Non-listen only connection not opened
283 _d / 11B _h	RPI is smaller than the production inhibit time
294 _d / 126 _h	Invalid configuration size
295 _d / 127 _h	Invalid originator to target size
296 _d / 128 _h	Invalid target to originator size
297 _d / 129 _h	Invalid configuration application path
298 _d / 12A _h	Invalid consuming application path
299 _d / 12B _h	Invalid producing application path
306 _d / 132 _h	Null forward open function not supported
517 _d / 205 _h	Parameter error in unconnected request service
789 _d / 315 _h	Invalid segment in connection path
Range 320h – 7FFh are vendor specific	
800 _d / 320 _h	Internal: Connection disabled
64258 _d / FB02 _h	Internal: Bad socket
64259 _d / FB03 _h	Internal: Bad originator to target net parameter
64260 _d / FB04 _h	Internal: Bad target to originator net parameter
64261 _d / FB05 _h	Internal: Bad UDP port
64262 _d / FB06 _h	Internal: Join multicast

Table 97. Connection Manager Object Error codes

Extended Status	Descriptions
64263 _d / FB07 _h	Internal: Prepare IO packet
64267 _d / FB0B _h	Internal: Consumption
64268 _d / FB0C _h	Internal: FW close
64270 _d / FB0E _h	Internal: Adapter stopped

9.1.5.4 Supported CIP and Vendor Objects

The Communication Interface supports the following object classes.

Table 98. CIP Objects

Type	Class	Object	Details
Required by Ether-Net/IP	1	Identity Object	See chapter 9.2.1.1
	2	Message Router Object	See chapter 9.2.1.2
	4	Assembly Object	See chapter 9.2.1.6
	6	Connection Manager Object	See chapter 9.2.1.3
	245d / F5h	TCP/IP Interface Object	See chapter 9.2.1.4
	246d / F6h	Ethernet Link Object	See chapter 9.2.1.5
Required by Drive Profile	40d / 28h	Motor Data Object	See chapter 9.2.1.7
	41d / 29h	Control Supervisor Object	See chapter 9.2.1.8
	42d / 2Ah	AC/DC Drive Object	See chapter 9.2.1.9
Vendor-Specific	160d / A0h	Vendor Parameters Object	See chapter 9.2.2.1
	161d / A1h	Motor Control Mode Object	See chapter 9.2.2.3
	162d / A2h	Fault History Object	See chapter 9.3.3.4
	190d / BEh	Assembly Instance Selector Object	See chapter 9.2.2.2

9.1.6 ETHERNET/IP COMMUNICATION AND CONNECTION TIMEOUT

The EtherNet/IP declares a watchdog the time within which both master and slave must send IO back to each other. This watchdog time is a factor of the communication cycle time (cycle time x timeout multiplier) and is set by the master. Minimum cycle time for OPTE9 EtherNet/IP is 1 millisecond.

In case of normal communication mode, 4 ms is the fastest recommended cycle time for Ethernet/IP. Faster cycle times (1 ms and 2 ms) are recommended in Fast Mode. See chapter 6.2 for more details.

When an IO message is not received within the watchdog time, the timeout setting value is activated and a fault is created after it elapses. This means that the panel parameter "Communication timeout" (refer to chapter 6.1.6) is used as an additional timeout value. The same logic applies if a connection is closed or the cable disconnects (link loss).

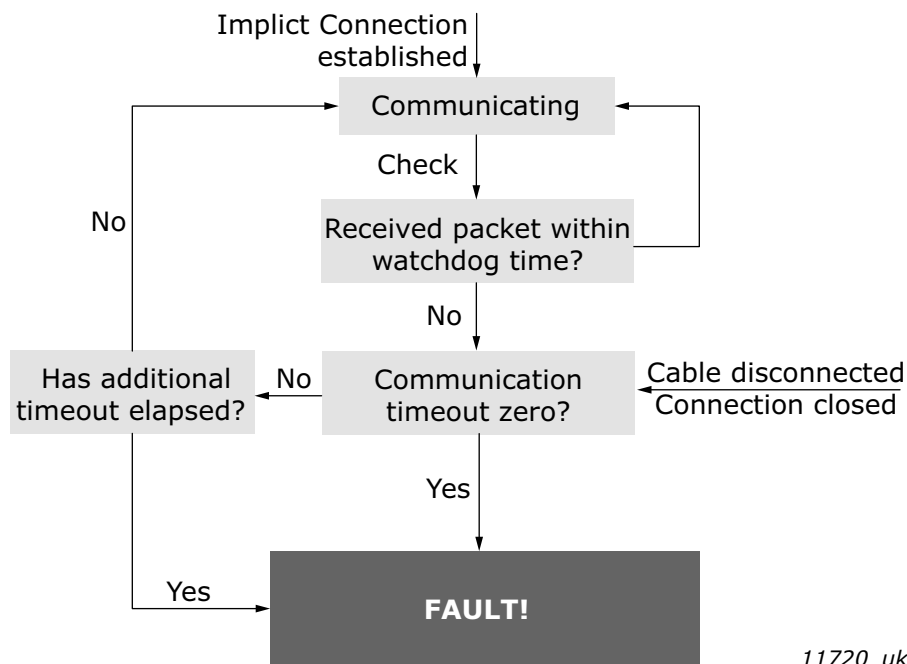

11720_uk

Figure 44. EtherNet/IP timeout logic with implicit connection (IO connection)

The explicit connections (TCP connection where PLC/user reads and writes data via CIP objects) will generate fieldbus fault only if that connection has been used to write process data over Assembly, Control Supervisor or AC/DC object. The explicit connection timeout is defined with TCP/IP Object's attribute 13d "Encapsulation Inactivity Timeout".

We recommend that implicit connection is used for motor control and explicit connections for "service data".

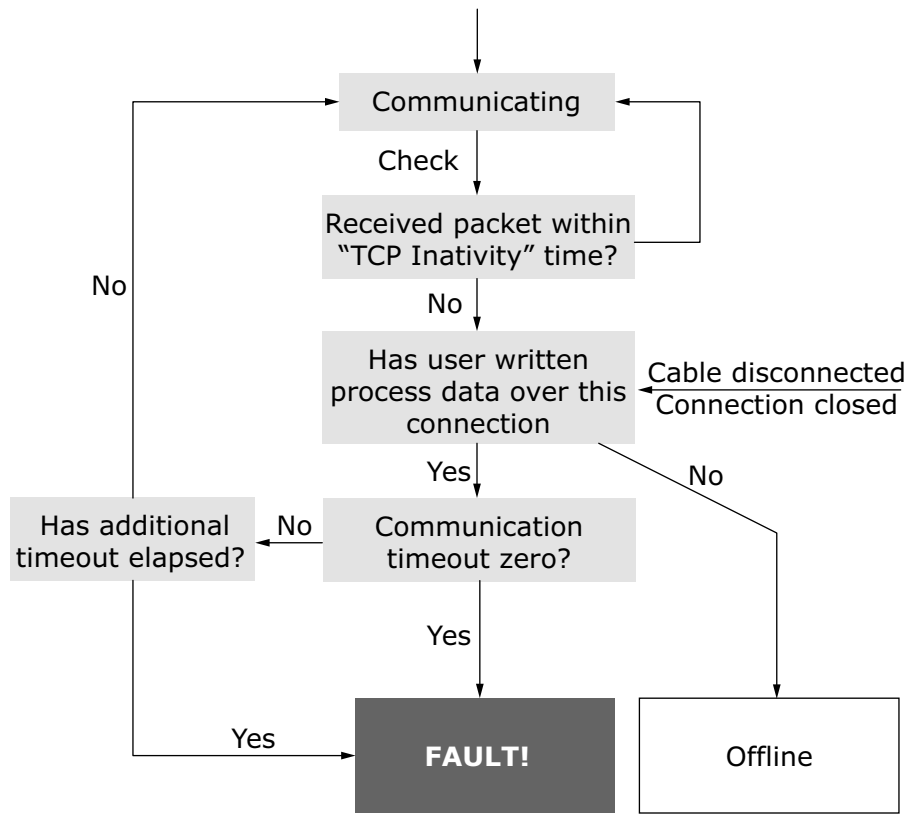

11721_uk

Figure 45. EtherNet/IP timeout logic with explicit connection

9.2 COMMON INDUSTRIAL OBJECTS IMPLEMENTED BY OPTE9

9.2.1 CIP OBJECTS

9.2.1.1 Identity Object, Class 0x01

The Identity Object provides identification of and general information about the device.

Table 99. Identity Object

Class name		Identity Object			
Class identifier		1			
Class Attributes	Id	Access rule	Name	Datatype	Description
	1	Get	Revision	UINT	Class revision (1)
	2	Get	Max Instance	UINT	Maximum instance number (1)
	3	Get	Number of Instances	UINT	Number of object instances(1)
Class Services	Id	Name		Description	
	1	Get_Attributes_All		Get all attributes	
	14 _d 0E _h	Get_Attribute_Single		Get single attribute	
Instance Attributes	Id	Access rule	Name	Datatype	Description
	1	Get	Vendor ID	UINT	Vendor identification
	2	Get	Device Type	UINT	General type of product
	3	Get	Product Code	UINT	Product identification
	4	Get	Revision	STRUCT of	Revision of the item the Identity Object represents
			Major Revision	USINT	
			Minor Revision	USINT	
	5		Status	WORD	Summary status of device
	6		Serial number	UDINT	Serial number of the device
	7		Product Name	SHORT STRING	Human readable identification
Instance Services	Id	Name		Description	
	1	Get_Attributes_All		Get all attributes	
	5	Reset		Only reset type 0	
	14 _d 0E _h	Get_Attribute_Single		Get single attribute	

9.2.1.1.1. INSTANCE ATTRIBUTES

Instance Attribute “Vendor ID”

This number is assigned to vendors of CIP devices by the ODVA user organization. The vendor ID for VACON[®] Ltd is 01BB_h(443_d).

Instance Attribute “Device Type”

This attribute indicates which device profile is implemented by the device. For VACON[®] AC drives this device number is 02_h(“AC Drive” profile).

Instance Attribute “Product Code”

This attribute reveals the vendor-assigned product code for a particular product within a device type.

Separate products must have different product codes if their configuration and/or runtime options are different.

OPTE9 will return the product code value based on the AC drive where the option board has been installed. This value can also be modified with the “Product Code Offset” parameter (see Chapter 6 “Commissioning”).

When the “Mode” setting is set to “NX Mode”, setting the “Product Code Offset” has no affect and OPTE9 will emulate the OPTCQ option board and return value to 2. The same functionality applies to the “V100 Mode”, except that the product code will be 100.

Table 100. AC drive Type Specific Product Code Values

AC drive type	Product Code Base Value
VACON [®] 20 AC drives	1000
VACON [®] 100 family AC drives	1100
VACON [®] NXS/NXP AC drives	1200
Emulating OPTCQ	2
Emulating V100	100

Instance Attribute “Revision”

This attribute, which consists of the Major and Minor Revision fields, identifies the revision of the item/ device that the Identity Object is representing. The Major Revision is limited to values between 1 and 127, as the eighth bit is reserved by CIP and is zero.

Instance Attribute “Status”

The value of the attribute presents the current status of the entire device. The coding of the field is defined in the table below.

Table 101. Status bit descriptions

Bit(s)	Called	Definition
0	Owned	TRUE, if device has owner
1		Reserved, is zero
2	Configured	TRUE, if device has been configured (always true in OPTE9)
3		Reserved, is zero

Table 101. Status bit descriptions

Bit(s)	Called	Definition	
		Value	Description
4-7	Extended Device Status	0	Self-testing or unknown
		1	Firmware upgrade in progress
		2	At least one faulted I/O connection
		3	No I/O connections established
		4	Non-Volatile configuration bad
		5	Major fault - either bit 10 or bit 11 is true
		6	At least one I/O connection in run mode
		7	At least one I/O connection established, all in idle mode
		8	The Status attribute is not applicable to this instance. Valid only for instances greater than one (1).
		9	Reserved
		10 thru 15	Vendor specific, not used by VACON®
8	Minor Recoverable fault	TRUE, if recoverable problem detected.	
9	Minor Unrecoverable Fault	TRUE, if unrecoverable problem detected.	
10	Major Recoverable Fault	TRUE, if recoverable problem detected.	
11	Major Unrecoverable Fault	TRUE, if unrecoverable problem detected.	
12-15	Extended Device Status 2	Reserved, is zero	

The OPTE9 drive implements bits 0, 2, and 4-11 according to the specification (Extended Device Status values 1, 4 and 8 to 15 are not used by VACON®). The bits 8-11 must be set according to the faults occurring in the drive.

Instance Attribute “Serial Number”

This attribute can be used in conjunction with the Vendor ID to form a unique identifier for each device on any CIP network.

The serial number is formed so that the first octet is 00 and the last 3 octets are taken from the end of the MAC address of the drive. For example, when the MAC address is 00:21:99:AA:BB:CC, then the serial number would be 00AABBCC.

Instance Attribute “Product Name”

This attribute contains human readable name identification for this instance. The OPTE9 will return the value which is combined from the drive type and application name. For example:

- “VACON® NX (APFIF06)”
- “VACON® 100 (1002)”
- “VACON® 20 (1009)”

When emulating the OPTCQ option board, the OPTE9 will always return text “OPTCQ” and when emulating VACON® 100 family AC drive: “VACON® 100”.

9.2.1.1.2. SERVICES

Instance Service “Reset”

The OPTE9 supports only reset type 0.

The reset type 0 means that the device represented by the Identity Object will as closely as possible emulate the cycling of power.

If an error is detected, an error response is returned. Otherwise a successful Reset response is returned.

9.2.1.2 Message Router Object, Class 0x02

The Message Router Object is mandatory in all CIP devices. It provides a messaging connection point through which a Client may address a service to any object class or instance in a target device. Although the object is mandatory, there are no mandatory attributes or services.

The OPTE9 drive does not currently implement any of the object’s services or attributes

Table 102. Message router object

Class name		Message Router Object			
Class identifier		2			
Class Attributes	Id	Access rule	Name	Datatype	Description
	-	-	-	-	-
Class Services	Id	Name		Description	
	-	-		-	
Instance Attributes	Id	Access rule	Name	Datatype	Description
	-	-	-	-	-
Instance Services	Id	Name		Description	
	-	-		-	

9.2.1.3 Connection Manager Object, Class 0x06

The communication characteristics between the applications in different devices are modelled using Connection Objects. The entities (devices) involved in a connection are referred to as end-points. A Connection Manager is required in some CIP networks to control the aspects of Connection object instances.

The Connection Manager class allocates and manages the internal resources associated with both I/O and Explicit Messaging connections.

Table 103. Connection manager object

Class name		Connection Manager Object			
Class identifier		6			
Class Attributes	Id	Access rule	Name	Datatype	Description
	1	Get	Revision	UINT	Class revision (1)
	2	Get	Max Instance	UINT	Maximum instance number (1)
	3	Get	Number of Instances	UINT	Number of object instances(1)

Table 103. Connection manager object

Class Services	Id	Name		Description	
	1	Get_Attributes_All		Returns content of all (implemented) attributes in the class.	
	14 _d 0E _h	Get_Attribute_Single		Used to read single attribute value.	
Instance Attributes	Id	Access rule	Name	Datatype	Description
	1	Get	Open Requests	UINT	Number of Forward Open service requests received.
	2	Get	Open Format Rejects	UINT	Number of Forward Open service requests which were rejected due to bad format.
	3	Get	Open Resource Rejects	UINT	Number of Forward Open service requests which were rejected due to lack of resources.
	4	Get	Open Other Rejects	UINT	Number of Forward Open service requests which were rejected for other reasons.
	5	Get	Close Requests	UINT	Number of Forward Close service requests received.
	6	Get	Close Format Rejects	UINT	Number of Forward Close service requests which were rejected due to bad format.
	7	Get	Close Other Rejects	UINT	Number of Forward Close service requests which were rejected for other reasons
	8	Get	Connection Timeouts	UINT	Total number of connection timeouts that have occurred in connections controlled by this Connection Manager.
Instance Services	Id	Name		Description	
	1	Get_Attributes_All		Returns content of all (implemented) attributes in the instance	
	14 _d 0E _h	Get_Attribute_Single		Used to read the single attribute value	
	78 _d 4E _h	Forward_Open		Opens a connection (maximum data size is 511 bytes)	
	84 _d 54 _h	Forward_Close		Closes a connection	

9.2.1.3.1. SERVICES

Instance Service “Forward Open”

The Forward Open service is used to open a connection to a target device. If the path between devices consists of multiple links, then local connections between these are also established.

The minimum time for the RPI (Request Packet Interval) is 1 ms. The connection object instance number is 103_d (67_h) except when emulating the OPTCQ option board. Then connection object instance number is 1.

Instance Service “Forward Close”

The Forward Close service is used to close a connection between two devices (and all nodes in the connection path).

9.2.1.4 TCP/IP Interface Object, Class 0xF5

The TCP/IP Interface Object provides an interface to configure the device’s TCP/IP settings. With this object, you can configure, for example, the device’s IP address, network mask and so on.

Table 104. TCP/IP interface object

Class name		TCP / IP object			
Class identifier		245 _d / F5 _h			
Class Attributes	Id	Access rule	Name	Datatype	Description
	1	Get	Revision	UINT	Class revision (4)
	2	Get	Max Instance	UINT	Maximum instance number (1)
	3	Get	Number of Instances	UINT	Number of object instances(1)
Class Services	Id	Name		Description	
	1	Get_Attributes_All		Returns content of all (implemented) attributes in the class.	
	14 _d 0E _h	Get_Attribute_Single		Used to read single attribute value.	

Table 104. TCP/IP interface object

	Id	Access rule	Name	Datatype	Description
Instance Attributes	1	Get	Status	DWORD	Interface status
	2	Get	Configuration Capability	DWORD	Interface capability flags
	3	Get/set	Configuration Control	DWORD	Interface control flags
	4	Get	Physical Link Object	STRUCT of	Path to physical link object
			Path size	UINT	Size of the path
			Path	Padded EPATH	Logical segments identifying the physical link object
	5	Get/set	Instance Configuration	STRUCT of	TCP/IP network interface configuration
			IP Address	UDINT	The device's IP address
			Network Mask	UDINT	The device's network mask
			Gateway Address	UDINT	Default gateway address
			Name Server	UDINT	Primary name server
			Name Server 2	UDINT	Secondary name server
			Domain Name	STRING	Default domain name
	6	Get/set	Host Name	STRING	Host name
	10 _d / 0A _h	Get/set	Select ACD	BOOL	Activates the use of ACD (enabled by default)
11 _d / 0B _h	Get	Last Conflict Detected	STRUCT of:	Structure containing information related to the last conflict detected.	
		ACD activity	USINT	State of ACD activity	
		Remote MAC	Array of 6 USINT	MAC address of last conflict source.	
		ARP PDU	Array of 28 USINT	Copy of the last ARP PDU in which a conflict was detected.	
13 _d / 0D _h	Set	Encapsulation Inactivity Timeout	UINT	Number of seconds of inactivity before TCP connection is closed	
Instance Services	Id	Name		Description	
	1	Get_Attributes_All		Returns content of all (implemented) attributes in the instance	
	14 _d / 0E _h	Get_Attribute_Single		Used to read single attribute value.	
	16 _d / 10 _h	Set_Attribute_Single		Used to write a single attribute value.	

9.2.1.4.1. INSTANCE ATTRIBUTES

Instance Attribute “Status”

This attribute presents the status of the TCP/IP network interface.

Table 105. Status Bit Descriptions

Bit(s)	Called	Definition		
0-3	Interface Configuration Status	Indicates the status of the interface configuration attribute	Value	Definition
			0	The Interface Configuration Attribute has not been configured
			1	The Interface Configuration Attribute contains valid configuration obtained from BOOTP, DHCP or non-volatile storage.
			2	The IP address member of the Interface Configuration Attribute contains valid configuration, obtained from hardware settings
3-15		Reserved for future use		
4	Mcast Pending	Indicates a pending configuration change in the TTL Value and/or Mcast Config attributes.		
5	Interface Configuration Pending	Indicates a pending configuration change in the Interface Configuration attribute.		
6	AcdStatus	Set(1) Address Conflict Detected, Clear(0) No Address Conflict Detected		
7-31	Reserved	Always zero		

Instance Attribute “Configuration Capability”

This attribute presents the capability flags (that is, the support for the optional network configuration capability) of the TCP/IP network interface.

Table 106. Configuration capability bit descriptions

Bit(s)	Called	Definition
0	BOOTP Client	Supports BOOTP (FALSE)
1	DNS Client	Supports capable of resolving DNS names (FALSE)
2	DHCP Client	Supports DHCP (TRUE)
3	DHCP-DNS Update	Always zero
4	Configuration Settable	TRUE, if configuration settable
5	Hardware Configurable	Configuration can be obtained from hardware settings (FALSE)
6	Interface Configuration Change Requires Reset	Configuration change results in reset (FALSE)
7	AcdCapable	Supports ACD (TRUE)
8-31	Reserved	Reserved, always zero

Instance Attribute “Configuration Control”

This attribute allows control of the TCP/IP network interface configuration.

When using the Configuration Control attribute, the device can be configured to use statically assigned IP values or DHCP. If the value is changed from DHCP to statically assigned, the device will continue using the current IP address. When changing from statically assigned to DHCP, the drive will try to get an IP address from the DHCP server. If this fails, the communication with the drive cannot be re-opened and you must set the IP address manually from the panel or enable the DHCP server in the network.

Changing the Configuration Control is not allowed if the I/O connection is open.

Table 107. Configuration control bit descriptions

Bit(s)	Called	Definition		
		Value	Definition	
0-3	Configuration Method	Determines how the device obtains its IP related configuration	0	The device uses statically-assigned IP configuration values.
			1	The device obtains its interface configuration values via BOOTP
			2	The device obtains its interface configuration values via DHCP
			3-15	Reserved for future use.
4	DNS Enable	If TRUE, the device resolves host names by querying a DNS server		
5-31	Reserved	Reserved, always zero		

In the OPTE9 product, if the “IP Address Mode” panel parameter is “Fixed IP”, the value of the Configuration Control is 0. If the “IP Address Mode” is “DHCP”, the value of the Configuration Control is 2.

The OPTE9 does not support BOOTP or DNS.

Instance Attribute “Physical Link Object”

This attribute identifies the object which is associated with the underlying physical communications interface (in the case of Ethernet, for example, the IEEE 802.3 interface). The attribute consists of two components; a Path Size, which reveals the number of UINT values in the path, and the Path itself.

In the OPTE9, the path points to an instance of the EtherNet Link Object. The value of the Path Size is 2 (total of four octets) and the value of the Path is 20_h F6_h 24_h XX_h, where XX is the instance number of the EtherNet Link object.

Instance Attribute “Instance Configuration”

This attribute contains the configuration parameters required for a device to operate as a TCP/IP node. The contents of the attribute depend on how the device has been configured to obtain its IP parameters (the “Configuration Method” field in the Configuration Control attribute). If the device uses a static IP address (Configuration Method value is 0), the values in the Interface Configuration are those statically assigned and stored in the non-volatile memory. If the device uses DHCP (or BOOTP) (Configuration Method value is 1 or 2), the Interface Configuration values will contain the configuration obtained through this channel. Until the BOOTP/DHCP reply is received, the values are 0.

Changing the Instance Configuration is not allowed when the I/O connection is open or Configuration Control-attribute is not set to “statically-assigned”.

The IP address, Network Mask and Gateway address consists of four bytes. For example, the IP address 192.168.0.10 would be in format: C0_h, A8_h, 00_h, 0A_h.

Table 108. Instance configuration

Interface Configuration	STRUCT of:	Description	Semantics of the value
IP address	UDINT	The device's IP address	Value of 0 indicates no IP address has been configured. Otherwise, the IP address must be set to a valid Class A, B, or C address and must not be set to the loopback address (127.0.0.1).
Network Mask	UDINT	The Device's network mask	Value of 0 indicates no network mask address has been configured.
Gateway Address	UDINT	Default gateway address	Value of 0 indicates no IP address has been configured. Otherwise, the IP address must be set to a valid Class A, B, or C address and must not be set to the loopback address (127.0.0.1).
Name Server	UDINT	Primary name server	Value of 0 indicates no name server address has been configured. Otherwise, the name server address must be set to a valid Class A, B, or C address.
Name Server 2	UDINT	Secondary name server	Value of 0 indicates no secondary name server address has been configured. Otherwise, the name server address must be set to a valid Class A, B, or C address.
Domain Name	STRING	Default domain name	ASCII characters. Maximum length is 48 characters. Must be padded to an even number of characters (pad not included in length). A length of 0 indicates that no Domain Name is configured.

Instance Attribute “Host Name”

This attribute contains the device's host name. The maximum length is 64 ASCII characters. The name is padded to an even number of characters. The Attribute Host Name is used only for information purpose.

Instance Attribute "Encapsulation Inactivity Timeout"

The Encapsulation Inactivity Timeout attribute is used to enable the TCP socket cleanup (closing) when the defined number of seconds have elapsed with no Encapsulation activity. The default value is 120 seconds. The TCP keep-alive traffic does not count as Encapsulation activity.

Table 109.

Value	Description
0	Disable
1-3600	Timeout in seconds

Instance Attribute "Select ACD"

This attribute is used to enable or disable ACD (Address Conflict Detection) functionality.

For more information see Chapter 4.5 "ACD (Address Conflict Detection)".

Instance Attribute "Last Conflict Detected"

This attribute contains information of the last IP address conflict. The content of this attribute can be resetted by writing zero to this attribute.

The struct member "ACD Activity" tells the state of ACD algorithm when the last conflict was detected. Possible values are defined in the table below.

Table 110. ACD Activity values

Value	ACD Mode	Description
0	No conflict detected (default)	No conflict has been detected since this attribute was last cleared.
1	Probe IPV4 address	Last conflict detected during IPV4 address probe state
2	Ongoing detection	Last conflict detected during OngoingDetection-state or subsequent DefendWithPolicyB state
3	Semi active probe	Last conflict detected during SemiActiveProbe-state or subsequent DefendWithPolicyB-state

The struct member "Remote MAC" tells the MAC address the source of the last IP address conflict.

The struct member "ARP PDU" contains the ARP message (raw copy) received from the source of the IP address conflict. Content of the ARP message is described in the table below.

Table 111. The ARP PDU in binary format

Field size (bytes)	Field Description
2	Hardware type (1 for Ethernet HW)
2	Protocol type (0x800 for IP)
1	Hardware size (6 for Ethernet HW)
1	Protocol size (4 for IP)
2	Operation code (1 for request or 2 for response)
6	Sender MAC address
4	Sender IP address
6	Target MAC address

Table 111. The ARP PDU in binary format

Field size (bytes)	Field Description
4	Target IP address

9.2.1.5 Ethernet Link Object, Class 0xF6

Ethernet Link Object provides interface to Ethernet link counters and attributes. With this object, user can retrieve for example link speed.

Table 112. Ethernet Link Object

Class name		Ethernet Link Object			
Class identifier		246 _d / F6 _h			
Class Attributes	Id	Access rule	Name	Datatype	Description
	1	Get	Revision	UINT	Class revision (4)
	2	Get	Max Instance	UINT	Maximum instance number (2)
	3	Get	Number of Instances	UINT	Number of object instances (2)
Class Services	Id	Name		Description	
	1	Get_Attributes_All		Returns content of all (implemented) attributes in the class.	
	14 _d 0E _h	Get_Attribute_Single		Used to read single attribute value.	
Instance Attributes	Id	Access rule	Name	Datatype	Description
	1	Get	Interface Speed	UDINT	Interface speed currently in use
	2	Get	Interface Flags	DWORD	Interface status flags
	3	Get	Physical Address	ARRAY of 6 USINTs	MAC layer address
	4	Get	Interface Counters	STRUCT of 11 UDINTs	Interface counters. See Table 114
	5	Get	Media Counters	STRUCT of 12 UDINTs	Media specific counters. See Table 115
	7	Get	Interface Type	USINT	Type of interface: twisted pair, fiber, internal, etc
	8	Get	Interface State	USINT	Current state of the interface: operational, disabled, etc
	9	Get/Set	Admin State	USINT	Administrative state: enable, disable
	10 _d 0A _h	Get	Interface Label	SHORT STRING	Human readable identification

Table 112. Ethernet Link Object

	Id	Name	Description
Instance Services	1	Get_Attributes_All	Returns content of all (implemented) attributes in the instance
	14 _d 0E _h	Get_Attribute_Single	Used to read single attribute value
	16 _d 10 _h	Set_Attribute_Single	Used to write a single attribute value.
	76 _d 4C _h	Get_and_Clear	Gets then clears the specified attribute (Interface Counters, Media Counters). Not instance/class dependent service.

9.2.1.5.1. INSTANCE ATTRIBUTES

Instance Attribute “Interface Speed”

The attribute reveals the currently used speed in the interface. The speed is announced as an integer number, with the unit Mbps, e.g. 0, 10, 100 etc. The value 0 indicates that the interface speed is indeterminate.

Instance Attribute “Interface Flags”

The attribute contains status and configuration information about the physical interface.

Table 113. Interface flag bit descriptions

Bit(s)	Called	Definition	
0	Link Status	One, if link is active	
1	Half/Full Duplex	One, if full duplex	
2-4	Negotiation Status	Value	Definition
		0	Auto-negotiation in progress
		1	Auto-negotiation and speed detection failed. Using default values for speed and duplex.
		2	Auto-negotiation failed but detected speed. Duplex was defaulted.
		3	Successfully negotiated speed and duplex.
4	Auto-negotiation not attempted. Forced speed and duplex.		
5	Manual Setting Requires Reset	0 indicates the interface can automatically activate changes to link parameters (auto-negotiate, duplex mode, interface speed). 1 indicates the device requires a Reset service be issued to its Identity Object in order for the changes to take effect.	
6	Local Hardware Fault	0 indicates the interface detects no local hardware fault; 1 indicates a local hardware fault is detected.	
7-31	Reserved	Always zero	

Instance Attribute “Physical Address”

The attribute reveals the MAC layer address of the physical interface.

Instance Attribute “Interface Counters”

The attribute is a collection of counters related to the Ethernet physical interface. The OPTE9 option board has only single MAC address and therefore implements only single set of counter values. Only packets sent or received by the device itself are counted.

Table 114. Interface counters

Field name	Data type	Description
In Octets	UDINT	The number of octets received on the interface (including framing characters).
In Unicast Packets	UDINT	The number of unicast packets received on the interface.
In NonUnicast Packets	UDINT	The number of non-unicast packets received on the interface.
In Discards	UDINT	Inbound packets received on the interface but which were discarded.
In Errors	UDINT	Inbound packets received on the interface but which contained errors (excluding Discards).
In Unknown Protocols	UDINT	Inbound packets received on the interface which belonged to unknown protocols.
Out Octets	UDINT	The number of octets sent on the interface (including framing characters).
Out Unicast Packets	UDINT	The number of unicast packets requested to be transmitted on the interface, including those that were discarded or not sent.
Out NonUnicast Packets	UDINT	The number of non-unicast packets requested to be transmitted on the interface, including those that were discarded or not sent.
Out Discards	UDINT	Outbound packets which were discarded.
Out Errors	UDINT	Outbound packets which contained errors (excluding Discards).

Instance Attribute “Media Counters”

The attribute is a collection of counters related to the Ethernet physical interface.

Table 115. Media counters

Field name	Data type	Description
Alignment Errors	UDINT	Frames received that are not an integral number of octets in length.
FCS Errors	UDINT	Frames received that do not pass the FCS check.
Single Collisions	UDINT	Successfully transmitted frames which experienced exactly one collision.
Multiple Collisions	UDINT	Successfully transmitted frames which experienced more than one collision.
SQE Test Errors	UDINT	The number of times SQE test error message is generated.
Deferred Transmissions	UDINT	Frames for which the first transmission attempt is delayed because the medium is busy.
Late Collisions	UDINT	Number of times a collision is detected later than 512 bit-times into the transmission of a packet.
Excessive Collisions	UDINT	Frames for which transmission fails due to excessive collisions.
MAC Transmit Errors	UDINT	Frames for which transmission fails due to an internal MAC sub layer transmit error.
Carrier Sense Errors	UDINT	Times that the carrier sense condition was lost or never asserted when attempting to transmit a frame.
Frame Too Long	UDINT	Frames received that exceed the maximum permitted enclosure size.
MAC Receive Errors	UDINT	Frames for which reception on an interface fails due to an internal MAC sub layer receive error.

Instance Attribute “Interface Type”

The attribute indicates the type of the Ethernet interface, i.e. twisted-pair cable, optical fiber, device-internal etc. The OPTE9 will always return the value 2, twisted-pair cable.

Instance Attribute “Interface State”

The attribute indicates the current state of the Ethernet interface, i.e. operational, disabled etc.

Table 116. Interface state

Value	Interface state
0	Unknown interface state
1	The interface is enabled and is ready to send and receive data
2	The interface is disabled
3	The interface is testing
4-255	Reserved

Instance Attribute “Admin State”

The attribute indicates the ability to use the Ethernet interface for administration, for example, for changing the settings.

The OPTE9 supports this attribute with the value 01_h (administration enabled). An attempt to disable the administration (by writing value 02_h) will result in an error.

9.2.1.6 Assembly Object, Class 0x04

The assembly object groups (or assembles) the attribute values into a single block of data.

Table 117. Assembly object

Class name		Assembly object			
Class identifier		4			
Class Attributes	Id	Access rule	Name	Datatype	Description
	1	Get	Revision	UINT	Class revision (2)
	2	Get	Max Instance	UINT	Maximum instance number (167 _d)
	3	Get	Number of Instances	UINT	Number of object instances (23)
Class Services	Id	Name		Description	
	1	Get_Attributes_All		Returns content of all (implemented) attributes in the class.	
	14 _d 0E _h	Get_Attribute_Single		Used to read single attribute value.	
Instance Attributes	Id	Access rule	Name	Datatype	Description
	3	Set	Data	ARRAY of BYTE	Assembly data
	4	Get	Size	UINT	Number of bytes in attribute 3 (assembly data)
Instance Services	Id	Name		Description	
	14 _d 0E _h	Get_Attribute_Single		Used to read single attribute value	
	16 _d 10 _h	Set_Attribute_Single		Used to write a single attribute value	

9.2.1.6.1. INSTANCE ATTRIBUTES

Instance Attribute “Data”

This attribute can be used to get assembly data. The content and length of the data depends on the configuration of the assembly instance.

Instance Attribute “Size”

This attribute can be used to get assembly data size.

9.2.1.7 Motor Data Object, Class 0x28

Motor Data Object provides interface to the motor data attributes, for example “motor type”.

Table 118. Motor data object

Class name		Motor data object			
Class identifier		40 _d / 28 _h			
Class Attributes	Id	Access rule	Name	Datatype	Description
	-	-	-	-	-
Class Services	Id	Name		Description	
	-	-		-	
Instance Attributes	Id	Access rule	Name	Datatype	Description
	3	Get/Set	MotorType	USINT	Motor type
	6	Get/Set	RatedCurrent	UINT	Rated Stator Current Units: [100mA]
	7	Get/Set	RatedVoltage	UINT	Rated Base Voltage Units: [V]
	9	Get/Set	RatedFreq	UINT	Rated Electrical Frequency Units: [Hz]
	12 _d 0C _h	Get	PoleCount	UINT	Number of poles in the motor.
	15 _d 0F _h	Get/Set	Base Speed	UINT	Nominal speed at rated frequency from name-plate Units: [RPM]
Instance Services	Id	Name		Description	
	14 _d 0E _h	Get_Attribute_Single		Used to read single attribute value.	
	16 _d 10 _h	Set_Attribute_Single		Used to write a single attribute value.	

9.2.1.7.1. INSTANCE ATTRIBUTES

Instance Attribute “MotorType”

The OPTE9 supports values 3 (Permanent Magnet Synchronous Motor) and 7 (Squirrel Cage Induction Motor).

Instance Attribute “RatedCurrent”

This attribute allows reading and writing of the motor rated current. The unit of the attribute is 100 milliamperes.

Instance Attribute “RatedVoltage”

This attribute allows reading and writing of the motor rated voltage. The unit of the attribute is 1 volt.

Instance Attribute “RatedFreq”

This attribute allows reading and writing of the motor rated electrical frequency. The unit of the attribute is 1 hertz.

Instance Attribute “PoleCount”

This attribute allows reading and writing of the number of poles in the motor. The unit of the attribute is 1.

Instance Attribute “Base Speed”

This attribute allows reading and writing of the nominal speed at rated frequency. The unit of the attribute is 1 RPM

9.2.1.8 Control Supervisor Object, Class 0x29

Control Supervisor Object provides an interface for drive management. You can, for example, start and stop the motor with this object.

Table 119. Control supervisor object

Class name		Control supervisor object			
Class identifier		41 _d / 29 _h			
Class Attributes	Id	Access rule	Name	Datatype	Description
		-	-	-	-
Class Services	Id	Name		Description	
	1	Get_Attributes_All		Returns content of all (implemented) attributes in the class.	
	14 _d 0E _h	Get_Attribute_Single		Used to read single attribute value.	
Instance Attributes	Id	Access rule	Name	Datatype	Description
	3	Get/Set	Run1	BOOL	Run forward
	4	Get/Set	Run2	BOOL	Run reverse
	5	Get/Set	NetCtrl	BOOL	Request Run/Stop control to be local or from network
	6	Get	State	USINT	State. See Table 121.
	7	Get	Running1	BOOL	True, when running forward
	8	Get	Running2	BOOL	True, when running in reverse
	9	Get	Ready	BOOL	True, when Ready or Enabled or Stopping
	10 _d 0A _h	Get	Faulted	BOOL	True, when fault is active
	11 _d 0B _h	Get	Warning	BOOL	True, when warning/alarm is active
	12 _d 0C _h	Get/Set	FaultRst	BOOL	Resets fault when transits from zero to one
	13 _d 0D _h	Get	FaultCode	UINT	If in Faulted-state, Fault-Code indicates the active fault. Otherwise last error or zero after startup.
	15 _d 0F _h	Get	CtrlFromNet	BOOL	True, control is from network False, control is local.
	21 _d 15 _h	Get/Set	NetIdleMode	USINT	Mode on reception of CIP communication IDLE event.

Table 119. Control supervisor object

	Id	Name	Description
Instance Services	5	Reset	Resets drive to startup state.
	14 _d 0E _h	Get_Attribute_Single	Used to read single attribute value.
	16 _d 10 _h	Set_Attribute_Single	Used to write a single attribute value.

9.2.1.8.1. INSTANCE ATTRIBUTES

Instance Attribute “Run1”

This attribute affects the run/stop behavior of the drive. See Table 120.

Instance Attribute “Run2”

This attribute affects the run/stop behavior of the drive. See Table 120.

Table 120. Run/Stop Event Matrix

Run1	Run2	Trigger event	Run type
0	0	Stop	N/A
0 -> 1	0	Run	Run1
0	0 -> 1	Run	Run2
0 -> 1	0 -> 1	No Action	N/A
1	1	No Action	N/A
1 -> 0	1	Run	Run2
1	1 -> 0	Run	Run1

Instance Attribute “NetCtrl”

This attribute allows the network to request the run/stop control to be assigned to the network. If the bit is 0, given control word is not updated to the drive. If the bit is 1, this means that the run/stop control is requested to this network interface.

NOTE! The actual assignment of the run/stop control to this network interface is reflected in attribute 15_d.

The OPTE9 will not force control to the network. You must change the control location (fieldbus/IO/ keypad) from the drive parameters.

Instance Attribute “State”

This attribute reveals the state of the device according to the table below. See also Chapter “9.2.1.8.3. Control Supervisor State Machine”.

Table 121. State Value Descriptions

Value	Definition
0	Vendor Specific
1	Startup
2	Not_Ready
3	Ready
4	Enabled
5	Stopping

Table 121. State Value Descriptions

Value	Definition
6	Fault_Stop
7	Faulted

Instance Attribute “Running1”

This attribute is used to describe the run state of the drive. The value of the attribute is 1, if one of the below conditions are fulfilled:

- The “State” attribute has the value 4 (“Enabled”) and the bit “Run1” has the value 1, **or**
- The “State” attribute has the value 5 (“Stopping”) and the bit “Running1” has the value 1, **or**
- The “State” attribute has the value 6 (“Fault_Stop”) and the bit “Running1” has the value 1

Otherwise, the value of this attribute is 0.

Instance Attribute “Running2”

This attribute is used to describe the run state of the drive. The value of the attribute is 1, if one of the below conditions are fulfilled:

- The “State” attribute has the value 4 (“Enabled”) and the bit “Run2” has the value 1, **or**
- The “State” attribute has the value 5 (“Stopping”) and the bit “Running2” has the value 1, **or**
- The “State” attribute has the value 6 (“Fault_Stop”) and the bit “Running2” has the value 1

Otherwise, the value of this attribute is 0.

Instance Attribute “Ready”

This attribute is used to signal the state of the drive that it is ready for operation. The value of the attribute is 1 if the value of the “State” attribute is either 3 (“Ready”), 4 (“Enabled”) or 5 (“Stopping”). Otherwise the value of this attribute is 0.

Instance Attribute “Faulted”

This attribute is used to signal that one or several faults have occurred in the drive. The value of the attribute is 1 if a fault has occurred and has not been acknowledged. Otherwise, the attribute has the value 0 indicating that no faults are present.

Instance Attribute “Warning”

This attribute is used to signal that one or several warnings have appeared in the drive. The value of the attribute is 1 if a warning has appeared and has not been acknowledged. Otherwise, the attribute has the value 0 indicating that no warnings are present.

Instance Attribute “FaultRst”

This attribute is used to reset faults and warnings in the drive. The attribute is write-only. Changing the value of the attribute from 0 to 1 (rising-edge) resets the faults in the drive. If the value is static 0, no reset action is started.

Instance Attribute “FaultCode”

This attribute is used to read the kind of fault which has caused the device to transition into the “Faulted” state. In the case of multiple faults occurring simultaneously, only one code is reported. If the device is not in the Faulted state, the FaultCode attribute indicates the fault which caused the last transition to the Faulted state.

Instance Attribute “CtrlFromNet”

It indicates whether the run/stop control is assigned to the local interface or to this network interface. When the value of the attribute is 0, the control is local. When the value of the attribute is 1, the run/stop control is assigned to the network interface.

Instance Attribute "NetIdleMode"

This attribute establishes the mode of operation on reception of network idle communication. Default value for this attribute is zero. Possible values are listed in the table below.

Table 122. NetIdleMode values

Mode	Action	Error/Warning
0	Stops motor	Fault
1	Ignored. IO data is not used, drive stays in state which was active before reception of IDLE	-
2	Vendor specific, fieldbus fault is activated (actual behavior depends on drive application and parametrization).	Fault
Other values are not supported		

9.2.1.8.2. SERVICES

Instance Service "Reset"

The Control Supervisor Object has a instance service named "Reset" which has the Service Code 05_h. The service resets the drive to the start-up state.

If an error is detected, an error response is returned. Otherwise a successful Reset response is returned.

9.2.1.8.3. CONTROL SUPERVISOR STATE MACHINE

The Control Supervisor Object defines a state machine for governing the behaviour of devices. The figure below describes the states and transitions of the state machine.

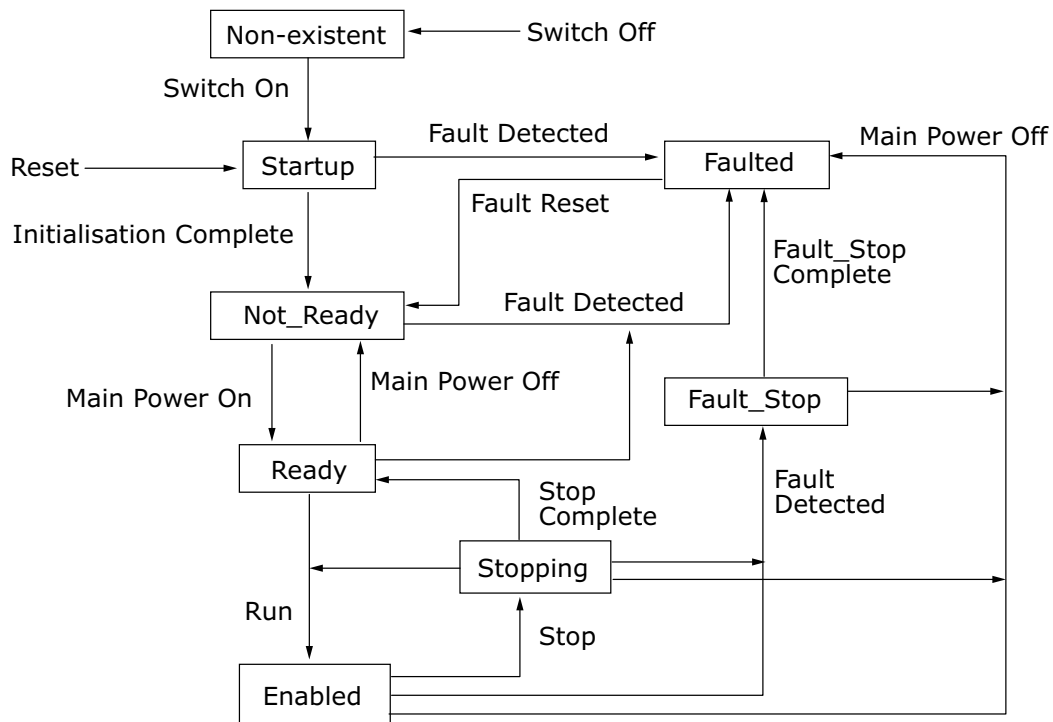

7082_UK

Figure 46. Control Supervisor State Machine

9.2.1.9 AC/DC Drive Object, Class 0x2A

The AC/DC Drive Object models the functions specific to an AC or DC drive.

Table 123. AC/DC drive object

Class name		AC/DC drive object			
Class identifier		42 _d / 2A _h			
Class Attributes	Id	Access rule	Name	Data-type	Description
	-	-	-	-	-
Class Services	Id	Name		Description	
	-	-		-	

Table 123. AC/DC drive object

Instance Attributes	Id	Access rule	Name	Data-type	Description
	3	Get/Set	AtReference	BOOL	True, when drive actual at reference (speed or torque reference) based on mode
	4	Get/Set	NetRef	BOOL	Requests torque or speed reference to be from the network. False, when Set Reference not DN Control True, when Set Reference at DN Control
	5	Get/Set	NetProc	BOOL	Requests process control reference to be from the network. False, when Set Process not DN Control True, when Set Process at DN Control
	6	Get	DriveMode	USINT	Drive mode. See Table 124.
	7	Get	SpeedActual	INT	Actual drive speed Units: $\text{RPM} / 2^{\text{SpeedScale}}$ where SpeedScale is attribute 22 _d
	8	Get	SpeedRef	INT	Speed reference Units: $\text{RPM} / 2^{\text{SpeedScale}}$ where SpeedScale is attribute 22 _d
	11 _d 0B _h	Get	TorqueActual	INT	Actual torque Units: $\text{Nm} / 2^{\text{TorqueScale}}$ where TorqueScale is attribute 24 _d
	12 _d 0C _h	Get/Set	TorqueRef	INT	Torque reference Units: $\text{Nm} / 2^{\text{TorqueScale}}$ where TorqueScale is attribute 24 _d
	13 _d 0D _h	Get	ProcessActual	INT	Actual process control value Units: % ProcessScale is not supported.
	14 _d 0E _h	Get/Set	ProcessRef	INT	Process control reference set point. Units: % ProcessScale is not supported
	22 _d 16 _h	Get/Set	SpeedScale	SINT	Speed scaling factor. Scaling is accomplished as follows: $\text{ScaledSpeed} = \text{RPM} / 2^{\text{SpeedScale}}$ Range: -4 .. 7
	24 _d 18 _h	Get/Set	TorqueScale		Torque scaling factor. Scaling is accomplished as follows: $\text{ScaledTorque} = \text{Nm} / 2^{\text{TorqueScale}}$ Range: -8 .. 7
29 _d 1D _h	Get	RefFromNet	BOOL	Status of torque/speed reference False, when local torque/speed reference. True, when network torque/speed reference	

Table 123. AC/DC drive object

	Id	Name	Description
Instance Services	14 _d 0E _h	Get_Attribute_Single	Used to read single attribute value.
	16 _d 10 _h	Set_Attribute_Single	Used to write a single attribute value.

9.2.1.9.1. INSTANCE ATTRIBUTES

Instance Attribute “AtReference”

This attribute indicates whether the actual value is at the reference value (e.g. the drive actual speed is the same as what is requested in the speed reference). If the bit is 1, the drive actual value is at the reference value.

Instance Attribute “NetRef”

When the bit is 1, the torque or speed reference is requested to be allocated to this network interface. If the bit is 0, then no such request is made.

NOTE! The actual assignment of the reference to this network interface is reflected in the attribute 29_d.

Instance Attribute “NetProc”

This attribute is used to request torque or speed reference to be local or from network. Values are:

- 0 = Set reference not DN control
- 1 = Set reference at DN control

Instance Attribute “DriveMode”

Allowed values for Drive Mode defined in the table below.

NOTE! The actual drive mode support depends on the used drive and application. Check the actual drive mode support from the drive application manual.

Table 124. Supported Drive Modes

Value	Name	Supported
0	Vendor-specific mode	Yes (Open loop frequency)
1	Open loop speed	Yes (Open loop speed)
2	Closed loop speed control	Yes (Closed loop speed)
3	Torque control	Yes (Open loop torque)
4	Process control (e.g. PI control)	No
5	Position control	No

Changes to DriveMode attribute must be reflected in the “Motor Control Mode Object”. The drive will respond with “Invalid attribute value” status code 0x09, if other values are written.

Instance Attribute “SpeedActual”

This attribute allows reading of the speed actual value. The unit of the attribute must be (RPM / 2^{SpeedScale}), where the SpeedScale is attribute 22_d.

If the SpeedScale attribute is not used by the master, the default unit [1 RPM] is assumed. This is equivalent to the value 0 being used for the SpeedScale.

Instance Attribute “SpeedRef”

This attribute allows reading and writing of the speed reference set point. The unit of the attribute must be $(\text{RPM} / 2^{\text{SpeedScale}})$, where SpeedScale is attribute 22_d.

If the SpeedScale attribute is not used by the master, the default unit [1 RPM] is assumed. This is equivalent to the value 0 being used for SpeedScale.

Instance Attribute “TorqueActual”

This attribute allows reading of the torque actual value. The unit of the attribute must be $(\text{Nm} / 2^{\text{TorqueScale}})$, where the TorqueScale is attribute 24_d.

If the TorqueScale attribute is not used by the master, the default unit [1 Nm] is assumed. This is equivalent to the value 0 being used for the TorqueScale.

Instance Attribute “TorqueRef”

This attribute allows reading and writing of the torque reference set point. The unit of the attribute must be $(\text{Nm} / 2^{\text{TorqueScale}})$, where the TorqueScale is attribute 24_d.

If the TorqueScale attribute is not used by the master, the default unit [1 Nm] must be assumed. This is equivalent to the value 0 being used for TorqueScale. To set the drive to the torque control, see Chapter 15 “APPENDIX 5 - FIELD BUS PARAMETRISATION”.

Instance Attribute “ProcessActual”

This attribute allows reading of the process actual value. The unit of the attribute must be $(\% / 2^{\text{ProcessScale}})$, where the ProcessScale is attribute 25_d. The OPTE9 EtherNet/IP does not support ProcessScale. See Chapter “9.3.1.1.4. Assembly Instance 25 – Extended Process Control Output” for details.

Instance Attribute “ProcessRef”

This attribute allows reading and writing of the process reference set point. The unit of the attribute must be $(\% / 2^{\text{ProcessScale}})$, where ProcessScale is attribute 25_d. The OPTE9 EtherNet/IP does not support ProcessScale. See Chapter “9.3.1.1.4. Assembly Instance 25 – Extended Process Control Output” for details.

Instance Attribute “SpeedScale”

The SpeedActual and SpeedRef values are scaled according to the value of this attribute. The default value is 0_d.

The largest allowed value for this attribute in the OPTE9 drive is 7 (allowing resolution of 0.0078 RPM) and the minimum allowed value is -4 (allowing resolution of 16 RPM). The maximum speed value for input/output is thus ca 524000 RPM.

Instance Attribute “TorqueScale”

The TorqueActual and TorqueRef values are scaled according to the value of this attribute. The default value is 0_d.

The largest allowed value for this attribute in the OPTE9 is 7 (allowing resolution of 0.0078 Nm) and the minimum allowed value is -8 (allowing resolution of 256 Nm). The maximum torque value for input/output is thus ca 8.4 MNm.

Instance Attribute “RefFromNet”

This attribute reveals whether the torque or speed reference is local or from the network. If the reference is local, the value of the attribute is 0. If the reference is from the network, then the value of the attribute is 1.

9.2.2 VENDOR SPECIFIC OBJECTS

9.2.2.1 Vendor Parameters Object, Class 0xA0

The Vendor Parameters Object is a vendor-specific object which allows the user to access any application parameter from the drive.

Table 125. Vendor parameter object

Class name		Vendor parameter object			
Class identifier		160 _d / A0 _h			
Class Attributes	Id	Access rule	Name	Datatype	Description
	-	-	-	-	-
Class Services	Id	Name		Description	
	-	-		-	
Instance Attributes	Id	Access rule	Name	Datatype	Description
	XX	Get/Set	Parameter Value	UINT	Parameter Value
Instance Services	Id	Name		Description	
	14 _d 0E _h	Get_Attribute_Single		Used to read single attribute value.	
	16 _d 10 _h	Set_Attribute_Single		Used to write a single attribute value.	

9.2.2.1.1. INSTANCE ATTRIBUTES

Instance Attribute “Parameter Value”

If you want to read the value of a drive parameter, for example, “Motor control mode” ID600_d, set the instance attribute to value 600_d and the instance number to 1 to the request. The data type of the parameter value can be 8, 16 or 32 bits.

The OPTE9 also supports an old method from the OPTCQ option board of reading/writing ID values when the PLC supports only 8 bit instance attributes. This method is bit more complex.

In this mode, set the instance number to high octet of the ID, and the instance attribute as low octet of the ID. For example, if you want to read the value of ID 2291_d (08F3_h), the Get_Attribute_Single service request is targeted at the Vendor Parameters class, instance 08_h and attribute F3_h.

9.2.2.1.2. SERVICES

Instance Service “Get_Attribute_Single”

When invoked in an instance, the parameter ID to be fetched from the drive is calculated, then the read operation is started and once available, a response is provided to the master.

The format of the message is as follows:

Table 126.

Field	Data
Service Code	0E _h
Class Code	A0 _h
Instance Number	01 _h
Attribute ID	XXXX _h

The old format of the message is as follows (OPTCQ option board):

Table 127.

Field	Data
Service Code	0E _h
Class Code	A0 _h
Instance Number	YY _h
Attribute ID	XX _h

Instance Service “Set_Attribute_Single”

When invoked in an instance, the parameter ID to be modified in the drive is calculated. The data type, write permission etc. are verified before the write operation is started. When the operation finishes, or if an error occurs, an appropriate response is provided to the master.

The format of the message is as follows:

Table 128.

Field	Data
Service Code	10 _h
Class Code	A0 _h
Instance Number	01 _h
Attribute ID	XXXX _h
Attribute Data	Parameter-specific

The old format of the message is as follows (OPTCQ option board):

Table 129.

Field	Data
Service Code	10 _h
Class Code	A0 _h
Instance Number	YY _h
Attribute ID	XX _h
Attribute Data	Parameter-specific

9.2.2.2 Assembly Instance Selector Object, Class 0xBE

The Assembly Instance Selector Object is a vendor-specific object available in the OPTCQ option board and the OPTE9. It allows the user to get and set the input and output instances used.

The OPTE9 option board will automatically change the current assembly instances by what is requested in the connection opening. This means that it is not mandatory to pre-set assembly instances.

Table 130. Assembly instance selector object

Class name		Assembly instance selector object			
Class identifier		190 _d / BE _h			
Class Attributes	Id	Access rule	Name	Datatype	Description
		-	-	-	-
Class Services	Id	Name		Description	
	-	-		-	
Instance Attributes	Id	Access rule	Name	Datatype	Description
	3	Get/Set	InputInstance	USINT	Input assembly instance
	4	Get/Set	OutputInstance	USINT	Output assembly instance
Instance Services	Id	Name		Description	
	14 _d 0E _h	Get_Attribute_Single		Used to read single attribute value.	
	16 _d 10 _h	Set_Attribute_Single		Used to write a single attribute value.	

9.2.2.2.1. INSTANCE ATTRIBUTES

Instance Attribute “InputInstance”

This attribute shows the currently active (or what was last used) input assembly instance id.

Instance Attribute “OutputInstance”

This attribute shows the currently active (or what was last used) output assembly instance id.

9.2.2.2.2. SERVICES

Instance Service “Get_Attribute_Single”

The format of the message is as follows.

Table 131.

Field	Data
Service Code	0E _h
Class Code	BE _h
Instance Number	01 _h
Attribute ID	03 _h or 04 _h

Instance Service “Set_Attribute_Single”

The format of the message is as follows:

Table 132.

Field	Data
Service Code	10 _h
Class Code	BE _h
Instance Number	01 _h
Attribute ID	03 _h or 04 _h
Attribute Data	(Assembly number)

9.2.2.2.3. REJECTION OF SET_ATTRIBUTE_SINGLE REQUEST

If an I/O connection has been established with a master through the Forward_Open request and a successful response, any request to set the selected assembly through the Assembly Instance Selector object is rejected. These attributes may only be changed when no I/O connection is established, i.e. before the Forward_Open request.

9.2.2.3 Motor Control Mode Object, Class 0xA1

The Motor Control Mode Object is a vendor-specific object available in the OPTE9 which more clearly indicates to the user which motor control mode is used, and allows the user to configure this mode.

Table 133. Motor Control Mode Object

Class name		Motor Control Mode Object			
Class identifier		161 _d / A1 _h			
Class Attributes	Id	Access rule	Name	Datatype	Description
	-	-	-	-	-
Class Services	Id	Name		Description	
	-	-		-	
Instance Attributes	Id	Access rule	Name	Datatype	Description
	1	Get/Set	ControlMode	USINT	Motor control mode
	2	Get/Set	FeedbackMode	USINT	Motor feedback mode

Table 133. Motor Control Mode Object

	Id	Name	Description
Instance Services	14 _d 0E _h	Get_Attribute_Single	Used to read single attribute value.
	16 _d 10 _h	Set_Attribute_Single	Used to write a single attribute value.

9.2.2.3.1. INSTANCE ATTRIBUTES

Instance Attribute “ControlMode”

This attribute is used to detect or change the used motor control mode. The values allowed for this attribute are listed in the table below.

Table 134. Motor Control Mode Values

Value	Description
0 _d	Frequency control
1 _d	Speed control
2 _d	Torque control

Instance Attribute “FeedbackMode”

This attribute is used to detect or change the used feedback mode. The values allowed for this attribute are listed in the table below.

After you have changed the feedback mode, you need to set the control mode, too. Only after that, the new feedback mode value is activated.

Table 135. Motor Feedback Mode Values

Value	Description
0 _d	Open Loop
1 _d	Closed Loop

ControlMode and FeedbackMode combinations

ControlMode and FeedbackMode combinations depends on used drive and application. Check the actual mode support from the AC drive’s application manual.

9.2.2.3.2. SERVICES

Instance Service “Get_Attribute_Single”

The service is used to get the value of an instance attribute.

The format of the message is as follows.

Table 136.

Field	Data
Service Code	0E _h
Class Code	BE _h
Instance Number	01 _h
Attribute ID	01 _h or 02 _h

Instance Service “Set_Attribute_Single”

The service is used to set the value of an instance attribute.

The format of the message is as follows.

Table 137.

Field	Data
Service Code	10 _h
Class Code	BE _h
Instance Number	01 _h
Attribute ID	01 _h or 02 _h
Attribute Data	(Mode number)

9.2.2.3.3. LINK TO AC/DC DRIVE OBJECT “DRIVEMODE” ATTRIBUTE

The Motor Control Mode Object is linked to the “DriveMode” attribute of the AC/DC Drive Object so, that changes in one affects the values in the other.

In the OPTE9, when the following values are set to the AC/DC Drive Object “DriveMode” attribute, the Motor Control Mode Object attributes are set to the following values:

Table 138.

Set DriveMode value	ControlMode value	FeedbackMode value
0 _d (Vendor specific)	0 _d (Frequency control)	0 _d (Open Loop)
1 _d (Open loop speed)	1 _d (Speed control)	0 _d (Open Loop)
2 _d (Closed loop speed)	1 _d (Speed control)	1 _d (Closed Loop)
3 _d (Torque control)	2 _d (Torque control)	*

*Feedback mode does not change. CIP does not define is torque control open or closed loop.

In the OPTE9, when the following values are set to the Motor Control Mode Object “ControlMode” and “FeedbackMode” attributes, the AC/DC Drive Object “DriveMode” attribute is set as follows:

Table 139.

Set Motor Control Mode Object values		DriveMode value
ControlMode	FeedbackMode	
0 _d (Frequency)	0 _d (Open loop)	1 _d (Vendor/frequency)
1 _d (Speed)	0 _d (Open loop)	1 _d (Open loop speed)
1 _d (Speed)	1 _d (Closed loop)	2 _d (Closed loop speed)
2 _d (Torque)	0 _d (Open loop) or 1 _d (Closed loop)	3 _d (Torque control)

9.2.2.4 Fault History Object, class 0xA2

The Fault History Object is a vendor-specific object available in the OPTE9 and in VACON® 100 family AC drive which allows access to the contents of the fault history over the EtherNet/IP network.

Each entry in a fault history is represented by an instance of the Fault History Object. Low instance numbers correspond to the most recent fault entries.

For the OPTE9, the revision of the object is 2.

Table 140. Fault history object

Class name		Fault history object			
Class identifier		162 _d / A2 _h			
Class Attributes	Id	Access rule	Name	Datatype	Description
	1	Get	Revision	UINT	Class revision (2)
	2	Get	Max Instance	UINT	Maximum instance number (40)
	3	Get	Number of Instances	UINT	Number of object instances. Depends on drive type.
Class Services	Id	Name		Description	
	1	Get_Attributes_All		Returns content of all (implemented) attributes in the class.	
	5	Reset		Reset fault history	
	14 _d 0E _h	Get_Attribute_Single		Used to read single attribute value.	
Instance Attributes	Id	Access rule	Name	Datatype	Description
	1	Get	FaultCode	UINT	Fault code
	2	Get	FaultID	UINT	Fault ID
	3	Get	FaultYear	UINT	Fault date: Year
	4	Get	FaultMonth	USINT	Fault date: Month
	5	Get	FaultDay	UINT	Fault date: Day
	6	Get	FaultMillisAfter Midnight	UDINT	Fault date: Time, milliseconds after midnight
Instance Services	Id	Name		Description	
	1	Get_Attributes_All		Returns content of all (implemented) attributes in the instance	
	14 _d 0E _h	Get_Attribute_Single		Used to read single attribute value	

9.2.2.4.1. CHANGES FROM REVISION 1 TO REVISION 2

The attributes FaultCode and FaultDay were changed from 8 bit to 16 bit.

9.2.2.4.2. CLASS ATTRIBUTES

Class Attribute “Revision”

This attribute presents the revision of the Fault History Object which is implemented by the device. The current revision is 2.

Class Attribute “Max Instance”

This attribute presents the maximum number of instances that can exist of the Fault History Object in the device. The maximum value is 40.

Class Attribute “Number of Instances”

This attribute presents the number of instances that currently exist of the Fault History Object in the device.

Table 141. Fault History Object - Number Of Instances

Drive	Maximum number of faults
VACON [®] 20 VACON [®] 20 X VACON [®] 20 CP	10
VACON [®] NXP	30
VACON [®] NXS	30
VACON [®] 100 family	40

9.2.2.4.3. INSTANCE ATTRIBUTES

Instance Attribute “FaultCode”

The value returns the fault code of a fault entry which is represented by the Fault History Object instance.

Instance Attribute “FaultID”

The value returns the fault ID of a fault entry which is represented by the Fault History Object instance. This value more exactly specifies which kind of fault is in question.

In case of VACON[®] NX and VACON[®] 20 family AC drives, the FaultID is the subcode of the fault.

Instance Attribute “FaultYear”

In VACON[®] 100 family AC drive, the attribute contains the year in which the fault occurred (according to the fault history). In other drives it contains the number of years the drive had been running until the fault occurred.

Instance Attribute “FaultMonth”

In VACON[®] 100 family AC drive, the attribute contains the month in which the fault occurred (according to the fault history). In other drives it is always zero.

Instance Attribute “FaultDay”

In VACON[®] 100 family AC drive, the attribute contains the day-of-month in which the fault occurred (according to the fault history). In other drives it contains the number of days the drive had been running since beginning of the year until the fault occurred.

Instance Attribute “FaultMillisAfterMidnight”

The attribute contains the number of milliseconds after midnight when the fault is time-stamped. The purpose of this format is to provide high accuracy and give you the possibility of representation according to 24-hour or 12-hour clock.

9.2.2.4.4. CLASS SERVICES

Class Service “Reset”

This service is used to reset the fault history of the drive.

9.3 ASSEMBLY INSTANCES IMPLEMENTED BY OPTE9

9.3.1 CIP I/O ASSEMBLY INSTANCES FOR AC/DC DRIVE

The OPTE9 supports the Output Assembly Instances 20, 21, 23 and 25, and the Input Assembly Instances 70, 71, 73 and 75.

The control word bits are mapped to the object data according to the table below.

Table 142. CIP Control Word Mapping To Object Data

Bit	Bit name	Object	Attribute name	Attribute ID
0	RunFwd	Control Supervisor Object	Run1	3 _d
1	RunRev	Control Supervisor Object	Run2	4 _d
2	FaultRst	Control Supervisor Object	FaultRst	12 _d
3	-	-	-	-
4	-	-	-	-
5	NetCtrl	Control Supervisor Object	NetCtrl	5 _d
6	NetRef	AC/DC Drive Object	NetRef	4 _d
7	NetProc	AC/DC Drive Object	NetProc	5 _d

The status word bits are mapped to the object data according to the table below.

Table 143. CIP Status Word Mapping to Object Data

Bit	Bit name	Object	Attribute name	Attribute ID
0	Faulted	Control Supervisor Object	Faulted	10 _d
1	Warning	Control Supervisor Object	Warning	11 _d
2	Running1	Control Supervisor Object	Running1	7 _d
3	Running2	Control Supervisor Object	Running2	8 _d
4	Ready	Control Supervisor Object	Ready	9 _d
5	CtrlFromNet	Control Supervisor Object	CtrlFromNet	15 _d
6	RefFromNet	AC/DC Drive Object	RefFromNet	29 _d
7	AtReference	AC/DC Drive Object	AtReference	3 _d

The process data IN is mapped according to the table below.

Table 144. Process Data IN Mapping To Object Data

Parameter name	Object	Attribute name	Attribute ID
Speed Reference	AC/DC Drive Object	SpeedRef	8 _d
Torque Reference	AC/DC Drive Object	TorqueRef (ProcessDataIn1)	12 _d
Process Reference	AC/DC Drive Object	ProcessRef If Drive Mode is: 0 = ProcessDataIn1 4 = ProcessDataIn2	14 _d
Drive Mode	AC/DC Drive Object	DriveMode	6 _d

The process data OUT is mapped according to the table below.

Table 145. Process Data OUT Mapping To Object Data

Parameter name	Object	Attribute name	Attribute ID
Speed Actual	AC/DC Drive Object	SpeedActual	7 _d
Torque Actual	AC/DC Drive Object	TorqueActual	11 _d
Process Actual	AC/DC Drive Object	ProcessActual (ProcessDataOut1)	13 _d
Drive State	Control Supervisor Object	State	6 _d

The Speed Reference is updated to the drive only when the NetRef bit is set to 1. The torque reference is updated to the drive only when the motor control mode is "Torque Control".

9.3.1.1 CIP Output Instances

9.3.1.1.1. ASSEMBLY INSTANCE 20 – BASIC SPEED CONTROL OUTPUT

Table 146.

Instance	Octet	Bit7	Bit6	Bit5	Bit4	Bit3	Bit2	Bit1	Bit0
20 (length 4)	0						Fault Reset		Run Fwd
	1								
	2	Speed Reference (Low Octet)							
	3	Speed Reference (High Octet)							

Control and Status Word monitoring values

When using this telegram, monitoring values contains values as shown in table below. Status word values depend on used input instance.

Table 147. Control and Status word monitoring values

Name	Value
Drive CW	FBFixedControlWord
Protocol CW	CIP Control Word

9.3.1.1.2. ASSEMBLY INSTANCE 21 – EXTENDED SPEED CONTROL OUTPUT

Table 148.

Instance	Octet	Bit7	Bit6	Bit5	Bit4	Bit3	Bit2	Bit1	Bit0
21 (length 4)	0		NetRef	NetCtrl			Fault Reset	Run Rev	Run Fwd
	1								
	2	Speed Reference (Low Octet)							
	3	Speed Reference (High Octet)							

Control and Status Word monitoring values

When using this telegram, monitoring values contains values as shown in table below. Status word values depend on used input instance.

Table 149. Control and Status Word monitoring values

Name	Value
Drive CW	FBFixedControlWord
Protocol CW	CIP Control Word

9.3.1.1.3. ASSEMBLY INSTANCE 23 – EXTENDED SPEED AND TORQUE CONTROL OUTPUT

Table 150.

Instance	Octet	Bit7	Bit6	Bit5	Bit4	Bit3	Bit2	Bit1	Bit0
23 (length 6)	0		NetRef	NetCtrl			Fault Reset	Run Rev	Run Fwd
	1								
	2	Speed Reference (Low Octet)							
	3	Speed Reference (High Octet)							
	4	Torque Reference (Low Octet)							
	5	Torque Reference (High Octet)							

Control and Status Word monitoring values

When using this telegram, monitoring values contains values as shown in table below. Status word values depend on used input instance.

Table 151. Control and Status Word monitoring values

Name	Value
Drive CW	FBFixedControlWord
Protocol CW	CIP Control Word

9.3.1.1.4. ASSEMBLY INSTANCE 25 – EXTENDED PROCESS CONTROL OUTPUT

The extended process control assembly can be used to send process reference value directly to the application. The Process Reference value destination can be selected with the Drive Mode byte according to the table below. This should be configured in the application as the receiving input. To the other direction (input assembly instance 75), the ProcessDataOut1 is always mapped to the Process Actual. Note that the process reference value is sent to the drive only when NetProc bit is set.

The VACON[®] AC drives do not support the actual “Process Control”-mode. Therefore the Drive Mode cannot be set to the Process Control by using the AC/DC Drive Object attribute, and the Drive Mode parameter in this assembly is only used to select the process reference. With these mappings, the Process Reference and Process Actual can be used with an application that supports the PID control.

Table 152. Drive Mode Selection in Process Control

Drive Mode	Process reference mapping
0	ProcessDataIn1

Table 152. Drive Mode Selection in Process Control

Drive Mode	Process reference mapping
4	ProcessDataIn2
Other	Not valid

Table 153.

Instance	Octet	Bit7	Bit6	Bit5	Bit4	Bit3	Bit2	Bit1	Bit0
23 (length 6)	0	Net-proc	NetRef	NetCtrl			Fault Reset	Run Rev	Run Fwd
	1	Drive Mode							
	2	Speed Reference (Low Octet)							
	3	Speed Reference (High Octet)							
	4	Process Reference (Low Octet)							
	5	Process Reference (High Octet)							

Control and Status Word monitoring values

When using this telegram, monitoring values contains values as shown in table below. Status word values depend on used input instance.

Table 154. Control and Status Word monitoring values

Name	Value
Drive CW	FBFixedControlWord
Protocol CW	CIP Control Word

9.3.1.2 CIP Input instances

9.3.1.2.1. ASSEMBLY INSTANCE 70 – BASIC SPEED CONTROL INPUT

Table 155.

Instance	Octet	Bit7	Bit6	Bit5	Bit4	Bit3	Bit2	Bit1	Bit0
70 (length 4)	0						Runnin g1		Faulted
	1								
	2	Speed Actual (Low Octet)							
	3	Speed Actual (High Octet)							

Control and Status Word monitoring values

When using this telegram, monitoring values contains values as shown in table below. Control word values depend on used output instance.

Table 156. Control and Status Word monitoring values

Name	Value
Drive SW	FBFixedStatusWord
Protocol SW	FBGeneralStatusWord

9.3.1.2.2. ASSEMBLY INSTANCE 71 – EXTENDED SPEED CONTROL INPUT

Table 157.

Instance	Octet	Bit7	Bit6	Bit5	Bit4	Bit3	Bit2	Bit1	Bit0
71 (length 4)	0	AtReference	Ref-From-Net	Ctrl-From-Net	Ready	Runnig2 (Rev)	Runnig1 (Fwd)	Warning	Faulted
	1	Drive State							
	2	Speed Actual (Low Octet)							
	3	Speed Actual (High Octet)							

Control and Status Word monitoring values

When using this telegram, monitoring values contains values as shown in table below. Control word values depend on used output instance.

Table 158. Control and Status Word monitoring values

Name	Value
Drive SW	FBFixedStatusWord
Protocol SW	FBGeneralStatusWord

9.3.1.2.3. ASSEMBLY INSTANCE 73 – EXTENDED SPEED AND TORQUE CONTROL INPUT

Table 159.

Instance	Octet	Bit7	Bit6	Bit5	Bit4	Bit3	Bit2	Bit1	Bit0
73 (length 6)	0	AtReference	Ref-From-Net	Ctrl-From-Net	Ready	Runnig2 (Rev)	Runnig1 (Fwd)	Warning	Faulted
	1	Drive State							
	2	Speed Actual (Low Octet)							
	3	Speed Actual (High Octet)							
	4	Torque Actual (Low Octet)							
	5	Torque Actual (High Octet)							

Control and Status Word monitoring values

When using this telegram, monitoring values contains values as shown in table below. Control word values depend on used output instance.

Table 160. Control and Status Word monitoring values

Name	Value
Drive SW	FBFixedStatusWord
Protocol SW	FBGeneralStatusWord

9.3.1.2.4. ASSEMBLY INSTANCE 75 – EXTENDED PROCESS CONTROL INPUT

See Chapter "9.3.1.1.4. Assembly Instance 25 – Extended Process Control Output" for details.

Table 161.

Instance	Octet	Bit7	Bit6	Bit5	Bit4	Bit3	Bit2	Bit1	Bit0
75 (length 6)	0	AtReference	Ref-From-Net	Ctrl-From-Net	Ready	Runnig2 (Rev)	Runnig1 (Fwd)	Warn- ing	Faulted
	1	Drive State							
	2	Speed Actual (Low Octet)							
	3	Speed Actual (High Octet)							
	4	Process Actual (Low Octet)							
	5	Process Actual (High Octet)							

Control and Status Word monitoring values

When using this telegram, monitoring values contains values as shown in table below. Control word values depend on used output instance.

Table 162. Control and Status Word monitoring values

Name	Value
Drive SW	FBFixedStatusWord
Protocol SW	FBGeneralStatusWord

9.3.2 VENDOR-SPECIFIC I/O ASSEMBLY INSTANCES

The OPTE9 supports multiple vendor specific assemblies.

Few of the instances use the CIP control and status words. Others use the vendor specific control and status words. All items started with "FB" are sent directly to the AC drive without any modifications.

Some of the vendor assemblies use the 32 bit process data values. Those are supported only in the VACON® 100 family AC drive. These assemblies can be used in other AC drives too, but the data will always be only 16 bit.

NOTE: Current firmware versions of VACON® 100 family and OPTE9 do not support transferring of 32 bit process data. Only the lower 16 bits are transferred.

9.3.2.1 Vendor Output Instances

9.3.2.1.1. ASSEMBLY INSTANCE 101

Table 163.

Instance	Octet	Bit7	Bit6	Bit5	Bit4	Bit3	Bit2	Bit1	Bit0
101 (length 8)	0		NetRef	NetCtrl			Fault Reset	Run Rev	Run Fwd
	1								
	2	FBSpeedReference (Low Octet) in %							
	3	FBSpeedReference (High Octet) in %							
	4	FBProcessDataIn1 (Low Octet)							
	5	FBProcessDataIn1 (High Octet)							
	6	FBProcessDataIn2 (Low Octet)							
	7	FBProcessDataIn2 (High Octet)							

Control and Status Word monitoring values

When using this telegram, monitoring values contains values as shown in table below. Status word values depend on used input instance.

Table 164. Control and Status Word monitoring values

Name	Value
Drive CW	FBFixedControlWord
Protocol CW	CIP Control Word

9.3.2.1.2. ASSEMBLY INSTANCE 111

Table 165.

Instance	Octet	Bit7	Bit6	Bit5	Bit4	Bit3	Bit2	Bit1	Bit0
111 (length 20)	0	FBFixedControlWord (Low Octet)							
	1	FBFixedControlWord (High Octet)							
	2	FBSpeedReference (Low Octet) in %							
	3	FBSpeedReference (High Octet) in %							
	4	FBProcessDataIn1 (Low Octet)							
	5	FBProcessDataIn1 (High Octet)							
	6	FBProcessDataIn2 (Low Octet)							
	7	FBProcessDataIn2 (High Octet)							
	8	FBProcessDataIn3 (Low Octet)							
	9	FBProcessDataIn3 (High Octet)							
	10	FBProcessDataIn4 (Low Octet)							
	11	FBProcessDataIn4 (High Octet)							
	12	FBProcessDataIn5 (Low Octet)							
	13	FBProcessDataIn5 (High Octet)							
	14	FBProcessDataIn6 (Low Octet)							
	15	FBProcessDataIn6 (High Octet)							
	16	FBProcessDataIn7 (Low Octet)							
	17	FBProcessDataIn7 (High Octet)							
	18	FBProcessDataIn8 (Low Octet)							
	19	FBProcessDataIn8 (High Octet)							

Control and Status Word monitoring values

When using this telegram, monitoring values contains values as shown in table below. Status word values depend on used input instance.

Table 166. Control and Status Word monitoring values

Name	Value
Drive CW	FBFixedControlWord
Protocol CW	FBFixedControlWord

9.3.2.1.3. ASSEMBLY INSTANCE 128

Table 167.

Instance	Octet	Bit7	Bit6	Bit5	Bit4	Bit3	Bit2	Bit1	Bit0
128 (length 20)	0	FBFixedControlWord (Low Octet)							
	1	FBGeneralControlWord (High Octet)							
	2	FBSpeedReference (Low Octet) in %							
	3	FBSpeedReference (High Octet) in %							
	4	FBProcessDataIn1 (Low Octet)							
	5	FBProcessDataIn1 (High Octet)							
	6	FBProcessDataIn2 (Low Octet)							
	7	FBProcessDataIn2 (High Octet)							
	8	FBProcessDataIn3 (Low Octet)							
	9	FBProcessDataIn3 (High Octet)							
	10	FBProcessDataIn4 (Low Octet)							
	11	FBProcessDataIn4 (High Octet)							
	12	FBProcessDataIn5 (Low Octet)							
	13	FBProcessDataIn5 (High Octet)							
	14	FBProcessDataIn6 (Low Octet)							
	15	FBProcessDataIn6 (High Octet)							
	16	FBProcessDataIn7 (Low Octet)							
	17	FBProcessDataIn7 (High Octet)							
	18	FBProcessDataIn8 (Low Octet)							
	19	FBProcessDataIn8 (High Octet)							

The contents of the assembly are otherwise identical to the output assembly 111, except that the second octet of the assembly is the high octet of FBGeneralControlWord instead of FBFixedControlWord.

Control and Status Word monitoring values

When using this telegram, monitoring values contains values as shown in table below. Status word values depend on used input instance.

Table 168. Control and Status Word monitoring values

Name	Value
Drive CW	FBFixedControlWord
Protocol CW	FBGeneralControlWord

9.3.2.1.4. ASSEMBLY INSTANCE 131

Table 169.

Instance	Offset	Octet 0	Octet +1	Octet +2	Octet +3
131 (length 40)	0	FBFixedControl- Word (Low Octet)	FBFixedControl- Word (High Octet)	FBGeneralCon- trolWord (Low Octet)	FBGeneralCon- trolWord (High Octet)
	4	Reserved	Reserved	FBSpeedRef (Low Octet)	FBSpeedRef (High Octet)
	8	FBProcessDataIn 1 Bits 7:0	FBProcessDataIn 1 Bits 15:8	FBProcessDataIn 1 Bits 23:16	FBProcessDataIn 1 Bits 31:24
	12	FBProcessDataIn 2 Bits 7:0	FBProcessDataIn 2 Bits 15:8	FBProcessDataIn 2 Bits 23:16	FBProcessDataIn 2 Bits 31:24
	16	FBProcessDataIn 3 Bits 7:0	FBProcessDataIn 3 Bits 15:8	FBProcessDataIn 3 Bits 23:16	FBProcessDataIn 3 Bits 31:24
	20	FBProcessDataIn 4 Bits 7:0	FBProcessDataIn 4 Bits 15:8	FBProcessDataIn 4 Bits 23:16	FBProcessDataIn 4 Bits 31:24
	24	FBProcessDataIn 5 Bits 7:0	FBProcessDataIn 5 Bits 15:8	FBProcessDataIn 5 Bits 23:16	FBProcessDataIn 5 Bits 31:24
	28	FBProcessDataIn 6 Bits 7:0	FBProcessDataIn 6 Bits 15:8	FBProcessDataIn 6 Bits 23:16	FBProcessDataIn 6 Bits 31:24
	32	FBProcessDataIn 7 Bits 7:0	FBProcessDataIn 7 Bits 15:8	FBProcessDataIn 7 Bits 23:16	FBProcessDataIn 7 Bits 31:24
	36	FBProcessDataIn 8 Bits 7:0	FBProcessDataIn 8 Bits 15:8	FBProcessDataIn 8 Bits 23:16	FBProcessDataIn 8 Bits 31:24

NOTE: Current firmware versions of VACON® 100 family and OPTE9 do not support transferring of 32 bit process data. Only the lower 16 bits are transferred.

Control and Status Word monitoring values

When using this telegram, monitoring values contains values as shown in table below. Status word values depend on used input instance.

Table 170. Control and Status Word monitoring values

Name	Value
Drive CW	FBFixedControlWord
Protocol CW	FBGeneralControlWord

9.3.2.1.5. ASSEMBLY INSTANCE 151

Table 171.

Instance	Octet	Bit 7	Bit 6	Bit 5	Bit 4	Bit 3	Bit 2	Bit 1	Bit 0
151 (length 38)	0	FBFixedControlWord (Low Octet)							
	1	FBFixedControlWord (High Octet)							
	2	FBGeneralControlWord (Low Octet)							
	3	FBGeneralControlWord (High Octet)							
	4	FBSpeedReference (Low Octet) in %							
	5	FBSpeedReference (High Octet) in %							
	6	FBProcessDataIn1 (Low Octet)							
	7	FBProcessDataIn1 (High Octet)							
							
	20	FBProcessDataIn8 (Low Octet)							
	21	FBProcessDataIn8 (High Octet)							
	22*	FBProcessDataIn9 (Low Octet)							
	23*	FBProcessDataIn9 (High Octet)							
							
	36*	FBProcessDataIn16 (Low Octet)							
37*	FBProcessDataIn16 (High Octet)								

* FBProcessDataIn9-16 will be available in future releases. At the moment, the incoming process data 9-16 is not handled.

Control and Status Word monitoring values

When using this telegram, monitoring values contains values as shown in table below. Status word values depend on used input instance.

Table 172. Control and Status Word monitoring values

Name	Value
Drive CW	FBFixedControlWord
Protocol CW	FBGeneralControlWord

9.3.2.1.6. ASSEMBLY INSTANCE 161

Table 173.

Instance	Octet	Bit 7	Bit 6	Bit 5	Bit 4	Bit 3	Bit 2	Bit 1	Bit 0
161 (length 36)	0		NetRef	NetCtrl			Fault Reset	RunRev	Run-Fwd
	1								
	2	FBSpeedReference (Low Octet) in %							
	3	FBSpeedReference (High Octet) in %							
	4	FBProcessDataIn1 (Low Octet)							
	5	FBProcessDataIn1 (High Octet)							
							
	18	FBProcessDataIn8 (Low Octet)							
	19	FBProcessDataIn8 (High Octet)							
	20*	FBProcessDataIn9 (Low Octet)							
	21*	FBProcessDataIn9 (High Octet)							
							
	34*	FBProcessDataIn16 (Low Octet)							
	35*	FBProcessDataIn16 (High Octet)							

* FBProcessDataIn9-16 will be available in future releases. At the moment, the incoming process data 9-16 is not handled.

Control and Status Word monitoring values

When using this telegram, monitoring values contains values as shown in table below. Status word values depend on used input instance.

Table 174. Control and Status Word monitoring values

Name	Value
Drive CW	FBFixedControlWord
Protocol CW	CIP Control Word

9.3.2.2 Vendor Input Instances

9.3.2.2.1. ASSEMBLY INSTANCE 107

Table 175.

Instance	Octet	Bit7	Bit6	Bit5	Bit4	Bit3	Bit2	Bit1	Bit0
107 (length 8)	0	AtReference	Ref-From-Net	Ctrl-From-Net	Ready	Running2 (Rev)	Running1 (Fwd)	Warning	Faulted
	1	Drive State							
	2	FBSpeedActual (Low Octet) in %							
	3	FBSpeedActual (High Octet) in %							
	4	FBProcessDataOut1 (Low Octet)							
	5	FBProcessDataOut1 (High Octet)							
	6	FBProcessDataOut2 (Low Octet)							
	7	FBProcessDataOut2 (High Octet)							

Control and Status Word monitoring values

When using this telegram, monitoring values contains values as shown in table below. Control word values depend on used output instance.

Table 176. Control and Status Word monitoring values

Name	Value
Drive SW	FBFixedStatusWord
Protocol SW	CIP Status Word

9.3.2.2.2. ASSEMBLY INSTANCE 117

Table 177.

Instance	Octet	Bit7	Bit6	Bit5	Bit4	Bit3	Bit2	Bit1	Bit0
117 (length 34)	0	FBFixedStatusWord (Low Octet)							
	1	FBFixedStatusWord (High Octet)							
	2	FBSpeedActual (Low Octet) in %							
	3	FBSpeedActual (High Octet) in %							
	4	RPMSpeedActual (Low Octet) in rpm							
	5	RPMSpeedActual (High Octet) in rpm							
	6	RPM With Slip SpeedActual (Low Octet) in rpm							
	7	RPM With Slip SpeedActual (High Octet) in rpm							
	8	Reserved (=0)							
	...	Reserved (=0)							
	17	Reserved (=0)							
	18	FBProcessDataOut1 (Low Octet)							
	19	FBProcessDataOut1 (High Octet)							
	20	FBProcessDataOut2 (Low Octet)							
	21	FBProcessDataOut2 (High Octet)							
	22	FBProcessDataOut3 (Low Octet)							
	23	FBProcessDataOut3 (High Octet)							
	24	FBProcessDataOut4 (Low Octet)							
	25	FBProcessDataOut4 (High Octet)							
	26	FBProcessDataOut5 (Low Octet)							
	27	FBProcessDataOut5 (High Octet)							
	28	FBProcessDataOut6 (Low Octet)							
	29	FBProcessDataOut6 (High Octet)							
	30	FBProcessDataOut7 (Low Octet)							
	31	FBProcessDataOut7 (High Octet)							
	32	FBProcessDataOut8 (Low Octet)							
	33	FBProcessDataOut8 (High Octet)							

Control and Status Word monitoring values

When using this telegram, monitoring values contains values as shown in table below. Control word values depend on used output instance.

Table 178. Control and Status Word monitoring value

Name	Value
Drive SW	FBFixedStatusWord
Protocol SW	FBFixedStatusWord

9.3.2.2.3. ASSEMBLY INSTANCE 127

Table 179.

Instance	Octet	Bit7	Bit6	Bit5	Bit4	Bit3	Bit2	Bit1	Bit0
127 (length 20)	0	FBFixedStatusWord (Low Octet)							
	1	FBGeneralStatusWord (High Octet)							
	2	FBSpeedActual (Low Octet) in %							
	3	FBSpeedActual (High Octet) in %							
	4	FBProcessDataOut1 (Low Octet)							
	5	FBProcessDataOut1 (High Octet)							
	6	FBProcessDataOut2 (Low Octet)							
	7	FBProcessDataOut2 (High Octet)							
	8	FBProcessDataOut3 (Low Octet)							
	9	FBProcessDataOut3 (High Octet)							
	10	FBProcessDataOut4 (Low Octet)							
	11	FBProcessDataOut4 (High Octet)							
	12	FBProcessDataOut5 (Low Octet)							
	13	FBProcessDataOut5 (High Octet)							
	14	FBProcessDataOut6 (Low Octet)							
	15	FBProcessDataOut6 (High Octet)							
	16	FBProcessDataOut7 (Low Octet)							
	17	FBProcessDataOut7 (High Octet)							
	18	FBProcessDataOut8 (Low Octet)							
	19	FBProcessDataOut8 (High Octet)							

Control and Status Word monitoring values

When using this telegram, monitoring values contains values as shown in table below. Control word values depend on used output instance.

Table 180. Control and Status Word monitoring values

Name	Value
Drive SW	FBFixedStatusWord
Protocol SW	FBGeneralStatusWord

9.3.2.2.4. INPUT ASSEMBLY INSTANCE 137

Table 181.

Instance	Offset	Octet 0	Octet +1	Octet +2	Octet +3
137 (length 40)	0	FBFixedStatus-Word (Low Octet)	FBFixedStatus-Word (High Octet)	FBGeneralStatus-Word (Low Octet)	FBGeneralStatus-Word (High Octet)
	4	Reserved	Reserved	FBSpeedActual (Low Octet)	FBSpeedActual (High Octet)
	8	FBProcessDataOutput1 Bits 7:0	FBProcessDataOutput1 Bits 15:8	FBProcessDataOutput1 Bits 23:16	FBProcessDataOutput1 Bits 31:24
	12	FBProcessDataOutput2 Bits 7:0	FBProcessDataOutput2 Bits 15:8	FBProcessDataOutput2 Bits 23:16	FBProcessDataOutput2 Bits 31:24
	16	FBProcessDataOutput3 Bits 7:0	FBProcessDataOutput3 Bits 15:8	FBProcessDataOutput3 Bits 23:16	FBProcessDataOutput3 Bits 31:24
	20	FBProcessDataOutput4 Bits 7:0	FBProcessDataOutput4 Bits 15:8	FBProcessDataOutput4 Bits 23:16	FBProcessDataOutput4 Bits 31:24
	24	FBProcessDataOutput5 Bits 7:0	FBProcessDataOutput5 Bits 15:8	FBProcessDataOutput5 Bits 23:16	FBProcessDataOutput5 Bits 31:24
	28	FBProcessDataOutput6 Bits 7:0	FBProcessDataOutput6 Bits 15:8	FBProcessDataOutput6 Bits 23:16	FBProcessDataOutput6 Bits 31:24
	32	FBProcessDataOutput7 Bits 7:0	FBProcessDataOutput7 Bits 15:8	FBProcessDataOutput7 Bits 23:16	FBProcessDataOutput7 Bits 31:24
	36	FBProcessDataOutput8 Bits 7:0	FBProcessDataOutput8 Bits 15:8	FBProcessDataOutput8 Bits 23:16	FBProcessDataOutput8 Bits 31:24

NOTE: Current firmware versions of VACON® 100 family and OPTE9 do not support transferring of 32 bit process data. Only the lower 16 bits are transferred.

Control and Status Word monitoring values

When using this telegram, monitoring values contains values as shown in table below. Control word values depend on used output instance.

Table 182. Control and Status Word monitoring values

Name	Value
Drive SW	FBFixedStatusWord
Protocol SW	FBGeneralStatusWord

9.3.2.2.5. ASSEMBLY INSTANCE 157

Table 183.

Instance	Octet	Bit7	Bit6	Bit5	Bit4	Bit3	Bit2	Bit1	Bit0
157 (length 38)	0	FBFixedStatusWord (Low Octet)							
	1	FBFixedStatusWord (High Octet)							
	2	FBGeneralStatusWord (Low Octet)							
	3	FBGeneralStatusWord (High Octet)							
	4	FBSpeedActual (Low Octet) in %							
	5	FBSpeedActual (High Octet) in %							
	6	FBProcessDataOut1 (Low Octet)							
	7	FBProcessDataOut1 (High Octet)							
							
	20	FBProcessDataOut8 (Low Octet)							
	21	FBProcessDataOut8 (High Octet)							
	22*	FBProcessDataOut9 (Low Octet)							
	23*	FBProcessDataOut9 (High Octet)							
							
	36*	FBProcessDataOut16 (Low Octet)							
37*	FBProcessDataOut16 (High Octet)								

* FBProcessDataOut9-16 will be available in future releases. At the moment, the outgoing process data 9-16 is zero.

Control and Status Word monitoring values

When using this telegram, monitoring values contains values as shown in table below. Control word values depend on used output instance.

Table 184. Control and Status Word monitoring values

Name	Value
Drive SW	FBFixedStatusWord
Protocol SW	FBGeneralStatusWord

9.3.2.2.6. ASSEMBLY INSTANCE 167

Table 185.

Instance	Octet	Bit7	Bit6	Bit5	Bit4	Bit3	Bit2	Bit1	Bit0
167 (length 36)	0	AtReference	RefFromNet	CtrlFromNet	Ready	Running2 (Rev)	Running1 (Fwd)	Warning	Faulted
	1	Drive State							
	2	FBSpeedActual (Low Octet) in %							
	3	FBSpeedActual (High Octet) in %							
	4	FBProcessDataOut1 (Low Octet)							
	5	FBProcessDataOut1 (High Octet)							
							
	18	FBProcessDataOut8 (Low Octet)							
	19	FBProcessDataOut8 (High Octet)							
	20*	FBProcessDataOut9 (Low Octet)							
	21*	FBProcessDataOut9 (High Octet)							
							
	34*	FBProcessDataOut16 (Low Octet)							
	35*	FBProcessDataOut16 (High Octet)							

* FBProcessDataOut9-16 will be available in future releases. At the moment, the outgoing process data 9-16 is zero.

Control and Status Word monitoring values

When using this telegram, monitoring values contains values as shown in table below. Control word values depend on used output instance.

Table 186. Control and Status Word monitoring values

Name	Value
Drive SW	FBFixedStatusWord
Protocol SW	CIP Status Word

9.3.3 MAPPING OF STANDARD OUTPUT ASSEMBLIES ONTO VACON® DATA

This section specifies how the data in the Standard Output Assemblies are mapped into VACON® data.

9.3.3.1 FBGeneralControlWord and FBGeneralStatusWord

FBGeneralControlWord and FBGeneralStatusWord are purely application specific. Check the used application’s manual for description of their content.

9.3.3.2 FBFixedControlWord

See Chapter 12 "APPENDIX 2 - CONTROL AND STATUS WORD".

9.3.3.3 Start/Stop bit in VACON® FBFixedControlWord

If one of the "RunFwd" or "RunRev" bits in an Output Assembly has the value 1, the "Start/Stop" bit 0 in the VACON® FBFixedControlWord is set to 1. Otherwise the bit is set to 0.

If both the "RunFwd" and "RunRev" bits have the value 1, no changes are done to FBFixedControlWord.

9.3.3.4 Direction bit in VACON® FBFixedControlWord

If the "RunRev" bit in an Output Assembly has the value 1, and the "RunFwd" bit in the assembly has the value 0, then the "Direction" bit 1 in the VACON® FBFixedControlWord is set to 1. Otherwise the bit is set to 0.

9.3.3.5 Fault Reset bit in VACON® FBFixedControlWord

The "Fault Reset" bit in an Output Assembly is mapped to the "Fault Reset" bit 2 in the VACON® FBFixedControlWord. Both bits are rising-edge sensitive.

9.3.3.6 Request Fieldbus Control bit in VACON® FBFixedControlWord

The "NetCtrl" bit in an Output Assembly is not mapped to the "Request Fieldbus Control" bit 8 in the VACON® FBFixedControlWord because this way you can place the drive to the IO or keypad control while fieldbus is active.

9.3.3.7 Request Fieldbus Reference bit in VACON® FBFixedControlWord

The "NetRef" bit in an Output Assembly is not mapped to the "Request Fieldbus Reference" bit 9 in the VACON® FBFixedControlWord.

9.3.3.8 Master Connection State bit in VACON® FBFixedControlWord

If the EtherNet/IP communication with the master device is functional, the bit 15 in the VACON® FBFixedControlWord is set to 1. If the communication with the master device is not working, the bit 15 in the FBFixedControlWord is set to 0.

9.3.4 MAPPING OF VACON® DATA ONTO STANDARD INPUT ASSEMBLIES

This section specifies how the VACON® data is mapped onto the data in the Standard Input Assemblies.

9.3.4.1 FBFixedStatusWord

See Chapter 12 "APPENDIX 2 - CONTROL AND STATUS WORD".

9.3.4.2 Ready Indication bit in VACON® FBFixedStatusWord

The "Ready Indication" bit 0 in the VACON® FBFixedStatusWord is mapped to the "Ready" bit in an Input Assembly which supports this bit.

9.3.4.3 Run/Stop Indication bit in VACON® FBFixedStatusWord

The “Run/Stop Indication” bit 1 in the VACON® FBFixedStatusWord is mapped to the “Running1” and “Running2” bits in an Input Assembly which supports these bits. The state of the Running1 and Running2 bits depends further on the “Direction Indication” bit 2 of the VACON® FBFixedStatusWord as follows:

Table 187. Run/Stop Bit Indication Map

	Run/Stop = 0	Run/Stop = 1	
	Direction = X	Direction = 0	Direction = 1
Running1	0	1	0
Running2	0	0	1

9.3.4.4 Direction Indication bit in VACON® FBFixedStatusWord

See chapter 9.3.4.3.

9.3.4.5 Fault Indication bit in VACON® FBFixedStatusWord

The “Fault Indication” bit 3 in the VACON® FBFixedStatusWord is mapped to the “Faulted” bit in an Input Assembly which supports this bit.

9.3.4.6 Alarm Indication bit in VACON® FBFixedStatusWord

The “Alarm Indication” bit 4 in the VACON® FBFixedStatusWord is mapped to the “Warning” bit in an Input Assembly which supports this bit.

9.3.4.7 Setpoint Reached Indication bit in VACON® FBFixedStatusWord

The “Setpoint Reached Indication” bit 5 in the VACON® FBFixedStatusWord is mapped to the “AtReference” bit in an Input Assembly which supports this bit.

9.3.4.8 Fieldbus Control indication in Input Assemblies

The selected control place is indicated in the Input Assemblies which contain the “CtrlFromNet” bit. If the control place is assigned to fieldbus then this bit is set to 1, else it is 0.

9.3.4.9 Fieldbus Reference indication in Input Assemblies

The selected reference is indicated in Input Assemblies which contain the “RefFromNet” bit. If the reference is assigned to fieldbus then this bit is set to 1, otherwise it is 0.

9.3.4.10 FBSpeedReference in percentage

This is the reference 1 to the AC drive. The allowed scaling is from 0 to 10000. In the application, the value is scaled in percentage of the frequency area between set minimum and maximum frequency.

9.4 ETHERNET/IP CONNECTION EXAMPLE

Preparing the connection

1. Set the EtherNet/IP as the active protocol from the OPTE9 panel parameters.
2. Set proper IP addresses.
3. Open a connection with the settings described in the table below.
4. Before trying to run motor, see Chapter 15 "APPENDIX 5 - FIELDBUS PARAMETRISATION" for information how to configure the drive.

Table 188.

Description	Instance	Size
Configuration instance	103 _d / 67 _h	0
Output instance	21 _d / 15 _h	4
Input instance	71 _d / 47 _h	4

1. Set control word to 0x0 (00000000)
2. Set control word to 0x61 (01100001) (NetRef, NetCtrl and Run Fwd enabled)
3. Drive status is: RUN
4. Set speed reference to 0x05EE (=25%)
5. Actual speed is 0x05EE (= 25% if MinFreq is 0Hz and MaxFreq is 50Hz)
6. Set control word 0x60 (01100000)
7. Drive status is: STOP

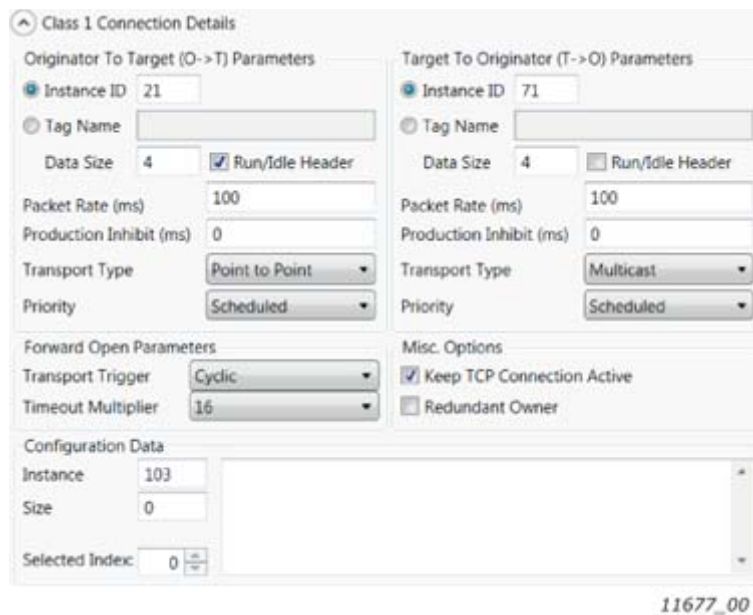

Figure 47. Configuration example from EIPScan Tool

10. FAULT TRACING

When the option board or the AC drive control diagnostics detect an unusual operating condition, the drive opens a notification, for example, on the keypad. The keypad shows the ordinal number of the fault, the fault code and a short fault description.

You can reset the fault with the Reset button on the control keypad, via the I/O terminal or via the used fieldbus protocol. The faults are stored in the Fault history menu, which can be browsed. The fault table presents only the fault conditions related to the fieldbus in use.

NOTE! When you contact a distributor or a factory because of a fault condition, always write down all the texts and codes on the keypad display. Then send the problem description together with the Drive Info File to the following address: tech.supportVDF@vacon.com. If possible, also send a "Wireshark" log from the situation if applicable.

10.1 TYPICAL FAULT CONDITIONS

Table 189. Typical fault conditions

Fault condition	Possible cause	Remedy
Cabling	Supply or motor cables are located too close to the fieldbus cable	
	Wrong type of fieldbus cable	
	Too long cabling	
Grounding	Inadequate grounding.	Ensure grounding in all the points on the net.
Connections	Faulty connections: Excessive stripping of cables	
	Faulty connections: Conductors in wrong terminals	
	Faulty connections: Too loose connections of conductors	
Parameter	Faulty address	
	Overlapping slave addresses	
	Wrong control place selected	

10.2 OTHER FAULT CONDITIONS

The following fault tracing diagram will help you to locate and fix some of the most usual problems. If the problem persists, contact your local distributor.

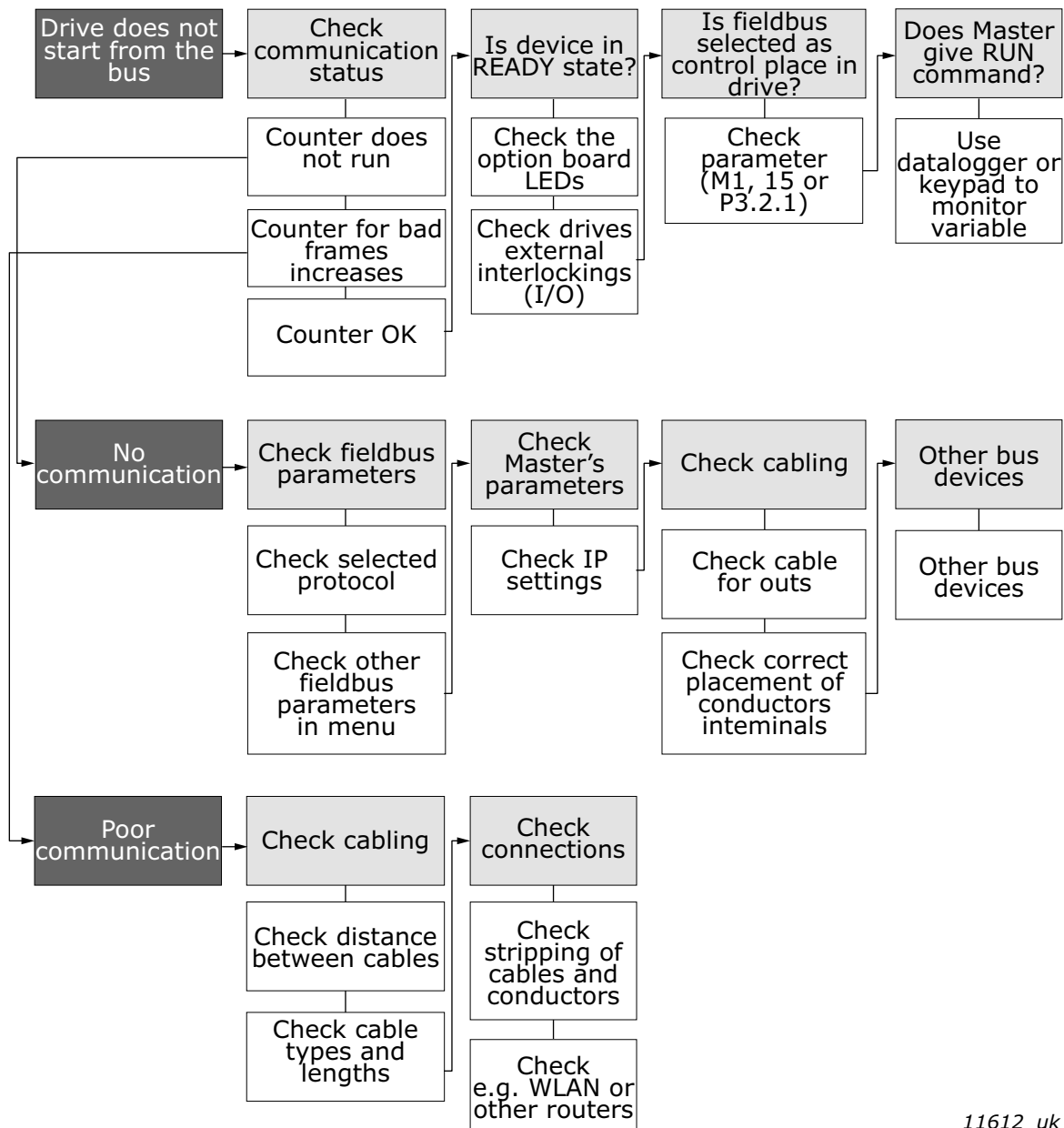

11612_uk

Figure 48. Fault tracing diagram for OPTE9

11. APPENDIX 1 - PROCESS DATA

Process Data IN (Master to Slave)

The use of Process Data In variables depends on the used application. The configuration of the data is free.

Process Data OUT (Slave to Master)

The use of Process Data Out variables depends on the used application. The Fieldbus Master can read the AC drive's actual values using process data variables. The control applications use the process data as follows:

Table 190. Process Data OUT variables

ID	Data	Value	Unit	Scale
2104	Process data OUT 1	Output Frequency	Hz	0.01 Hz
2105	Process data OUT 2	Motor Speed	rpm	1 rpm
2106	Process data OUT 3	Motor Current	A	0.1 A
2107	Process data OUT 4	Motor Torque	%	0.10 %
2108	Process data OUT 5	Motor Power	%	0.10 %
2109	Process data OUT 6	Motor Voltage	V	0.1 V
2110	Process data OUT 7	DC link voltage	V	1 V
2111	Process data OUT 8	Active Fault Code	-	-

12. APPENDIX 2 - CONTROL AND STATUS WORD

12.1 CONTROL WORD BIT DESCRIPTION

The Control word is composed of 32 bits. `FBFixedControlWord` consist of the first 16 bits. `FBGeneralControlWord` consist of the remaining 16 bits. While the functionality of `FBFixedControlWord` is fixed in the VACON® standard applications, the functionality of `FBGeneralControlWord` is totally application specific and can vary even in the VACON® standard applications.

The meanings of `FBFixedControlWord` bits are described below. Unused bits have to be set to zero.

NOTE! This table is valid for VACON® standard applications.

NOTE! There are some control word bit modifications in VACON® NXP AC drive. These modifications are described in Table 192. Unused bits have to be set to zero.

Table 191. `FBFixedControlWord` bits

Bit	Function		Description
B0	Start/Stop	0	Stop request from fieldbus.
		1	Run request from fieldbus.
B1	Direction	0	Requested direction is "FORWARD".
		1	Requested direction is "REVERSE".
B2	Fault reset	0	No action.
		1	No action. Rising edge (0->1) = Active faults, alarms and infos are reset.
B3	Stop mode 1	0	Stop mode is unmodified.
		1	Stop mode is overridden to "Coasting".
B4	Stop mode 2	0	Stop mode is unmodified.
		1	Stop mode is overridden to "Ramping".
B5	Quick ramp time	0	Normal deceleration ramp time.
		1	Deceleration ramp time is switched to shorter than normal.
B6	Freeze Setpoint	0	Changes in the setpoint value from fieldbus (FB Speed Reference) are taken into use by the application.
		1	Changes in the setpoint value from fieldbus (FB Speed Reference) are not taken into use by the application.
B7	Setpoint to Zero	0	The setpoint value from fieldbus is taken from FB Speed Reference.
		1	The setpoint value from fieldbus is changed to 0.
B8	Request Fieldbus Control	0	Control Place is as parameterized in the drive (unchanged).
		1	Control Place is overridden to Fieldbus Control.
B9	Request Fieldbus Reference	0	Source of the setpoint value is as parameterized in the drive (unchanged).
		1	Source of the setpoint value is overridden to Fieldbus.

Table 191. FBFixedControlWord bits

Bit	Function		Description
B10	Jogging 1	0	No action.
		1	Jogging request with ref1.
B11	Jogging 2	0	No action.
		1	Jogging request with ref2.
B12	Quick stop	0	Drive operates as normal.
		1	Drive executes quick stop / emergency stop.
B13	Reserved	0	-
		1	-
B14	Reserved	0	-
		1	-
B15	Reserved	0	-
		1	-

Table 192. FBFixedControWord modifications in VACON® NXP

Bit	Function	Value	Description
3	Fieldbus DIN 1	0	Fieldbus DIN 1 off
		1	Fieldbus DIN 1 on
4	Fieldbus DIN 2	0	Fieldbus DIN 2 off
		1	Fieldbus DIN 2 on
5	Fieldbus DIN 3	0	Fieldbus DIN 3 off
		1	Fieldbus DIN 3 on
6	Fieldbus DIN 4	0	Fieldbus DIN 4 off
		1	Fieldbus DIN 4 on
7	Fieldbus DIN 5	0	Fieldbus DIN 5 off
		1	Fieldbus DIN 5 on

12.2 STATUS WORD DESCRIPTIONS

The Status word is composed of 32 bits. FBFixedStatusWord consist of the first 16 bits. FBGeneralStatusWord consist of the remaining 16 bits. While the functionality of FBFixedStatusWord is fixed in the VACON® standard applications, the functionality of FBGeneralStatusWord is totally application specific and can vary even in the VACON® standard applications.

The meanings of FBFixedStatusWord bits are described below. Unused bits have to be set to zero.

In VACON® NX series AC drives the FBFixedStatusWord comes from firmware variable "MCStatus".

Table 193. FBFixedStatusWord bits

Bit	Function		Description
B0	Ready	0	Drive is not ready.
		1	Drive is ready to run.
B1	Run	0	Motor is not running.
		1	Motor is running.
B2	Direction	0	Motor is running clockwise.
		1	Motor is running counterclockwise.
B3	Fault	0	No fault active.
		1	Drive has an active fault.
B4	Alarm	0	No alarm active.
		1	Drive has active alarm.
B5	At reference	0	Motor is not running at reference speed.
		1	Motor is running at reference speed.
B6	Zero speed	0	Motor is not at zero speed.
		1	Motor is running at zero speed.
B7	Flux ready	0	Motor is not magnetized.
		1	Motor is magnetized.
B8-B12	Reserved		

12.3 CONTROL WORD BIT SUPPORT IN DRIVES

This table describes the control word bit support in different AC drives. Notice that this table is valid only for the VACON[®] standard applications. Always check the application-specific status from the application manual.

Table 194. Control word

Bit	Function	VACON [®] 100 family	VACON [®] NXS/ NXP	VACON [®] 20	VACON [®] 20 X
B0	Start/Stop	x	x	x	x
B1	Direction	x	x	x	x
B2	Fault reset	x	x	x	x
B3	Stop mode 1	x			x
B4	Stop mode 2	x			x
B5	Quick ramp time	x		x	x
B6	Freeze setpoint	x			x
B7	Setpoint to zero	x			x
B8	Request fieldbus control	x	x		x
B9	Request fieldbus reference	x	x		x
B10	Jogging 1	x			
B11	Jogging 2	x			
B12	Quick stop	x			x
B13	Reserved				
B14	Reserved				
B15	Reserved				

12.4 STATUS WORD BIT SUPPORT IN DRIVES

This table describes the status word bit support in different drives. Notice that this table is valid only for the VACON® standard applications. Always check the application-specific status from the application manual.

Table 195. Status word

Bit	Function	VACON® 100 family	VACON® NXS/ NXP	VACON® 20	VACON® 20 X
B0	Ready	x	x	x	x
B1	Run	x	x	x	x
B2	Direction	x	x	x	x
B3	Fault	x	x	x	x
B4	Alarm	x	x	x	x
B5	At reference	x	x	x	x
B6	Zero speed	x	x		x
B7	Flux ready	x	x		
B8	Reserved				
B9	Reserved				
B10	Reserved				
B11	Reserved				
B12	Reserved				
B13	Reserved				
B14	Reserved				
B15	Reserved				

13. APPENDIX 3 - EXAMPLE WITH SIEMENS PLC

13.1 SIEMENS STEP 7

1. Create a project

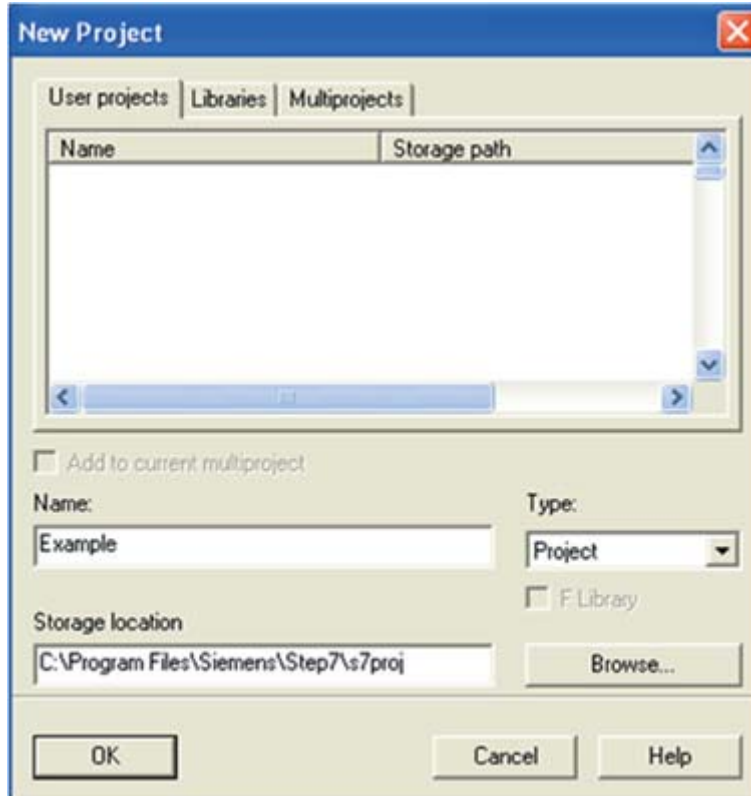

11613_00

2. Insert the station

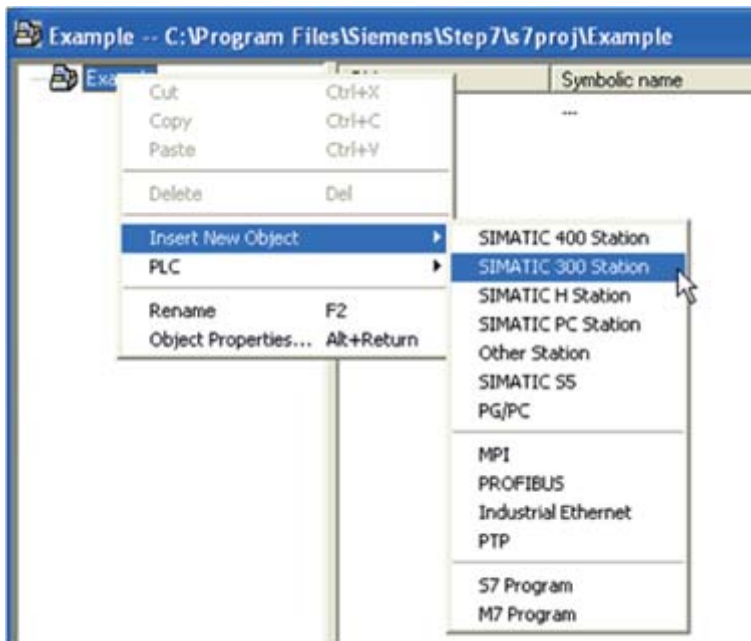

11614_00

3. Double-click the “Hardware” icon to open the HW config window.

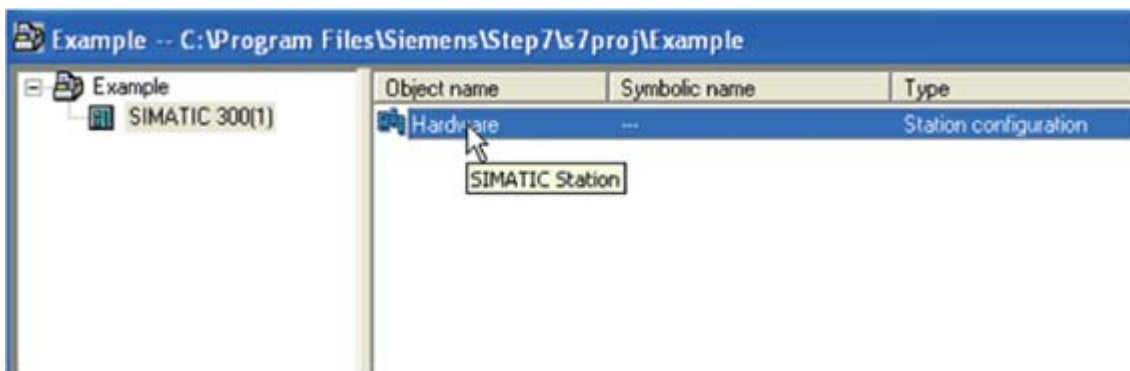

11615_00

4. Insert the rail

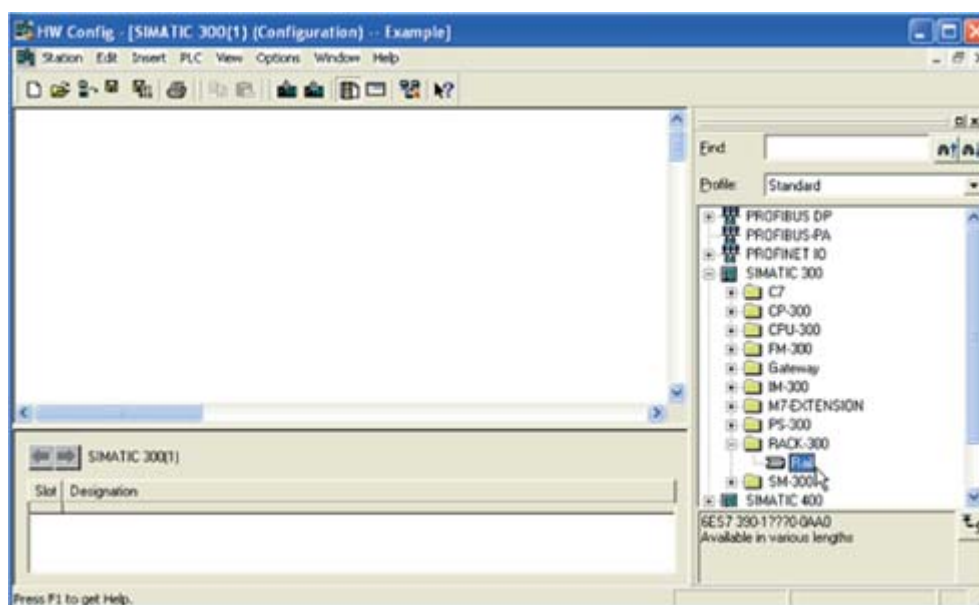

11616_00

5. Insert the power supply

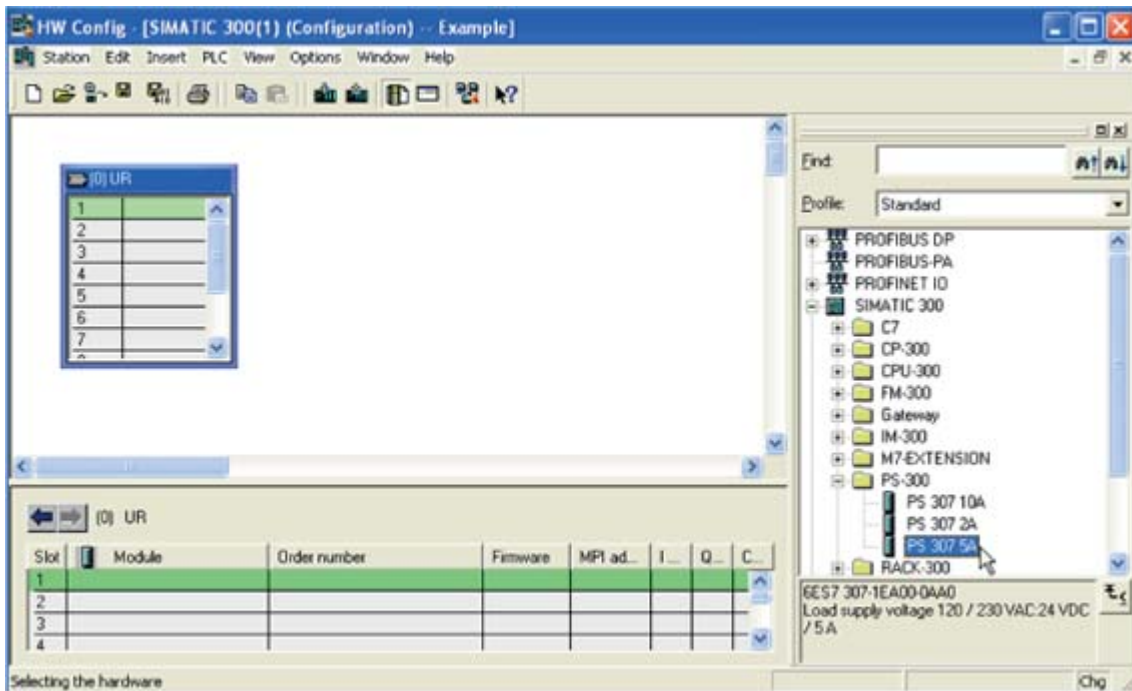

11617_00

6. Insert the CPU

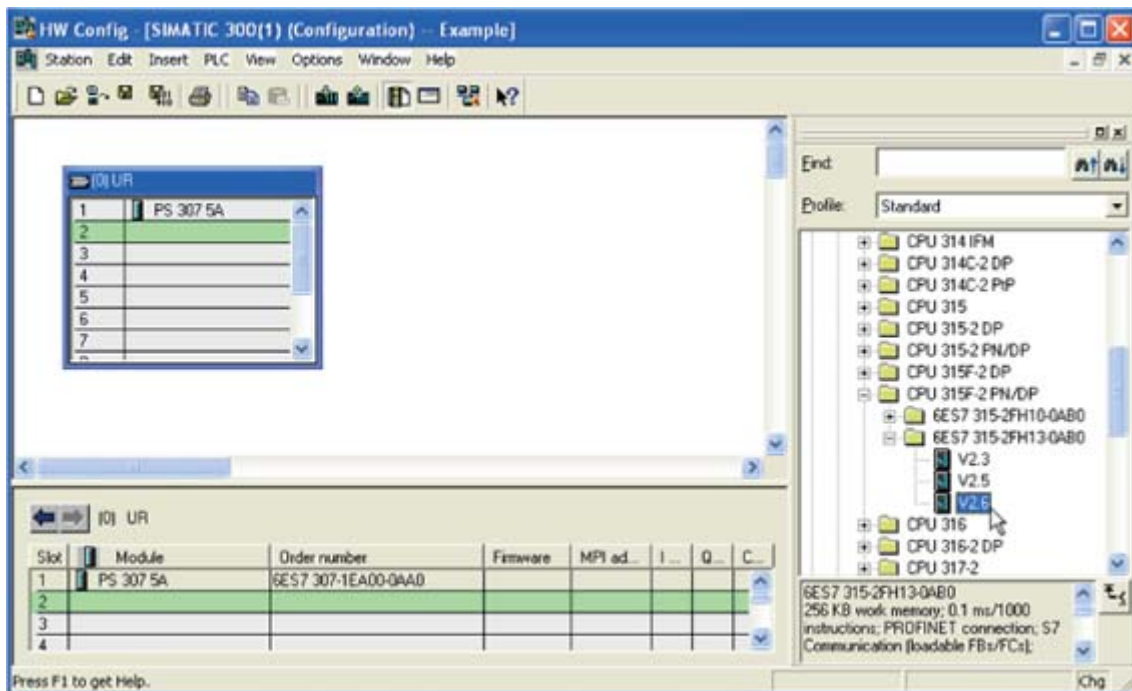

11618_00

7. Change the IP address and select the subnet by clicking **New**.

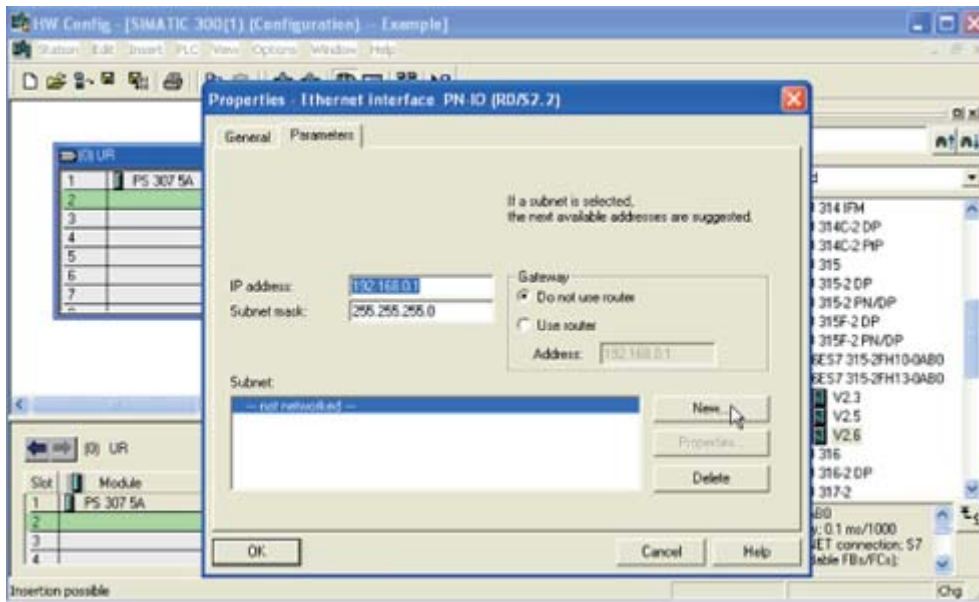

11619_00

8. Click OK

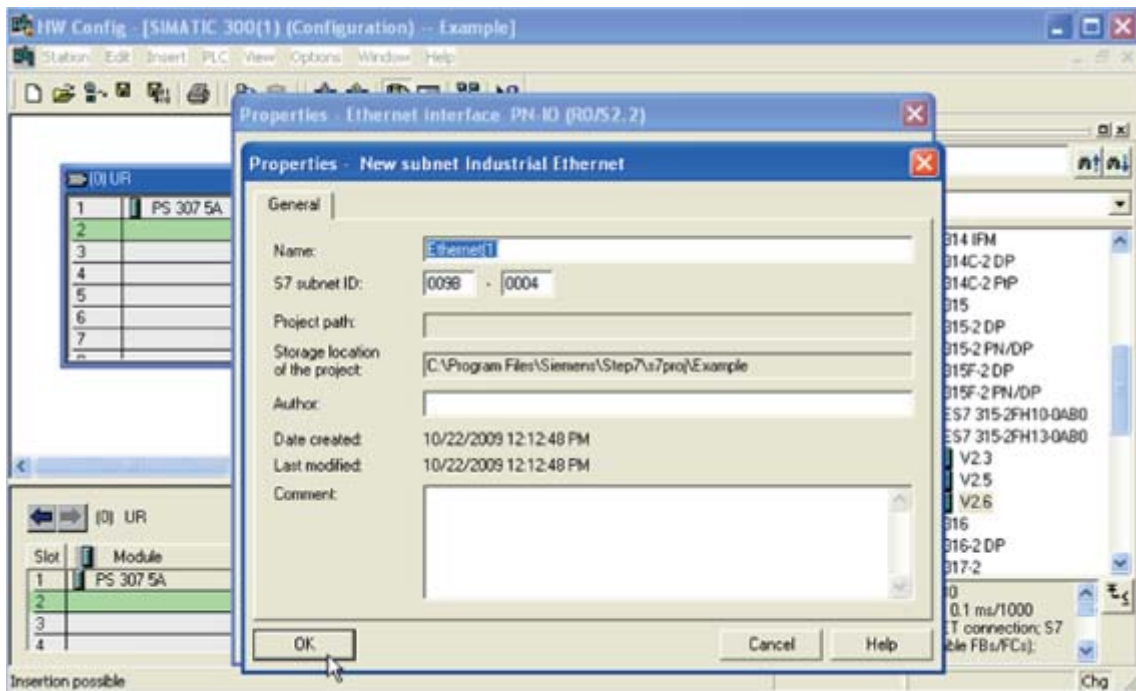

11620_00

9. Click OK

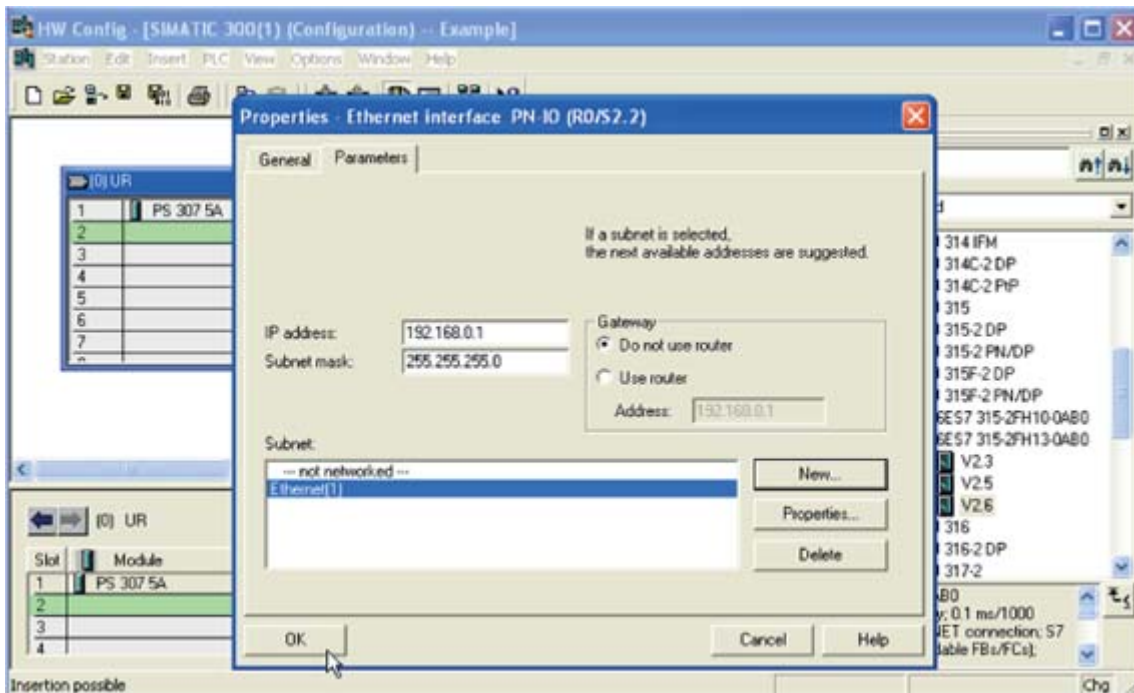

11621_00

10. Now the configuration is looks like this:

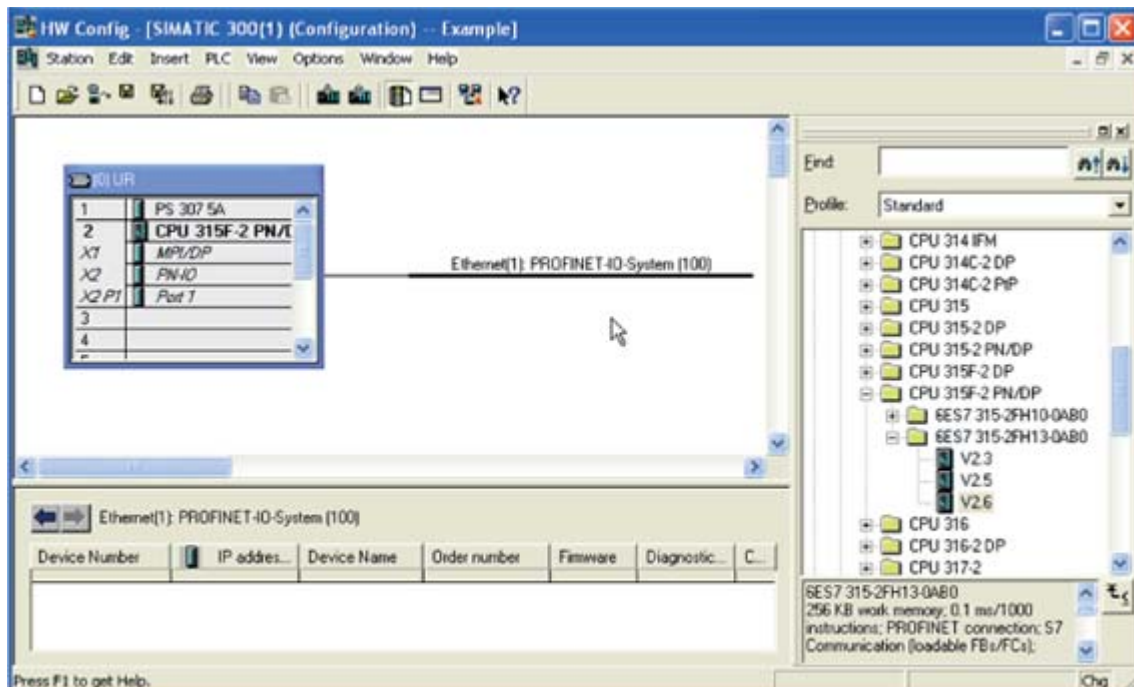

11622_00

11. Drag and drop the OPTE9 to Profinet IO system

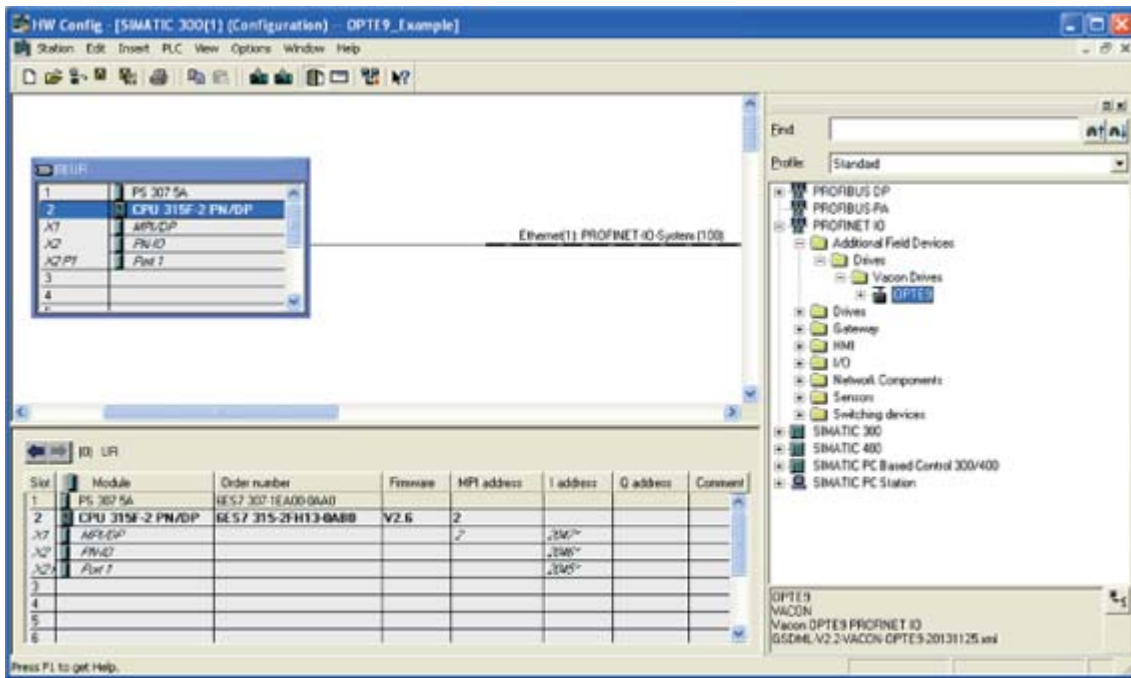

11623_00

12. Select a communication profile

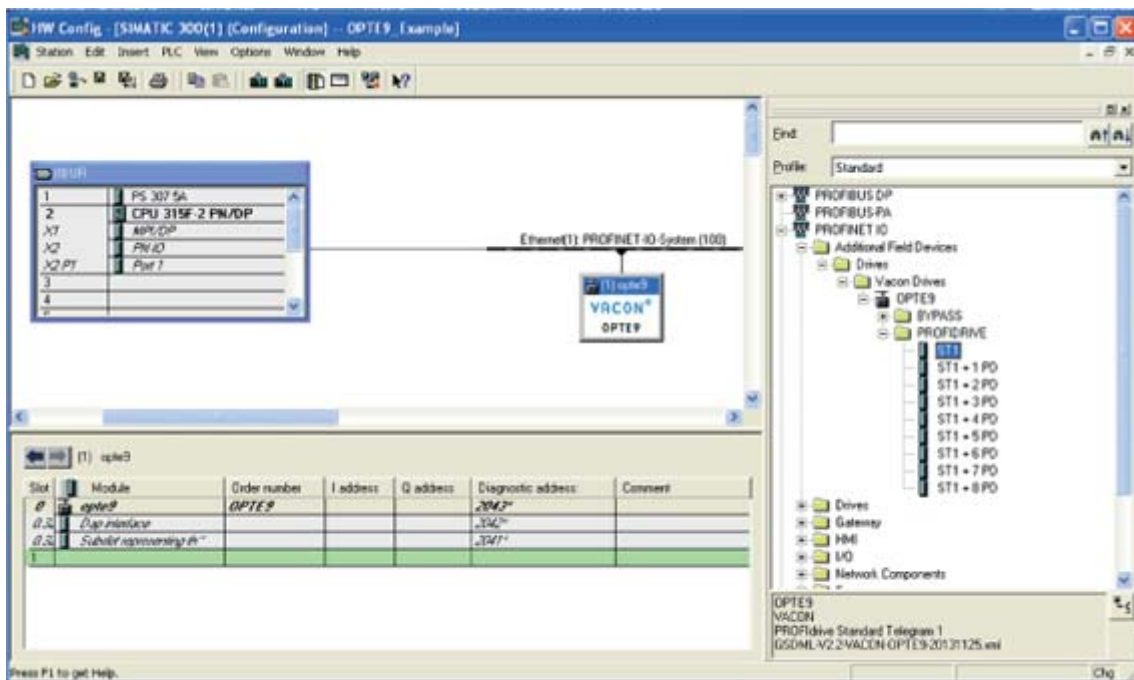

11624_00

13. Change the Option board properties

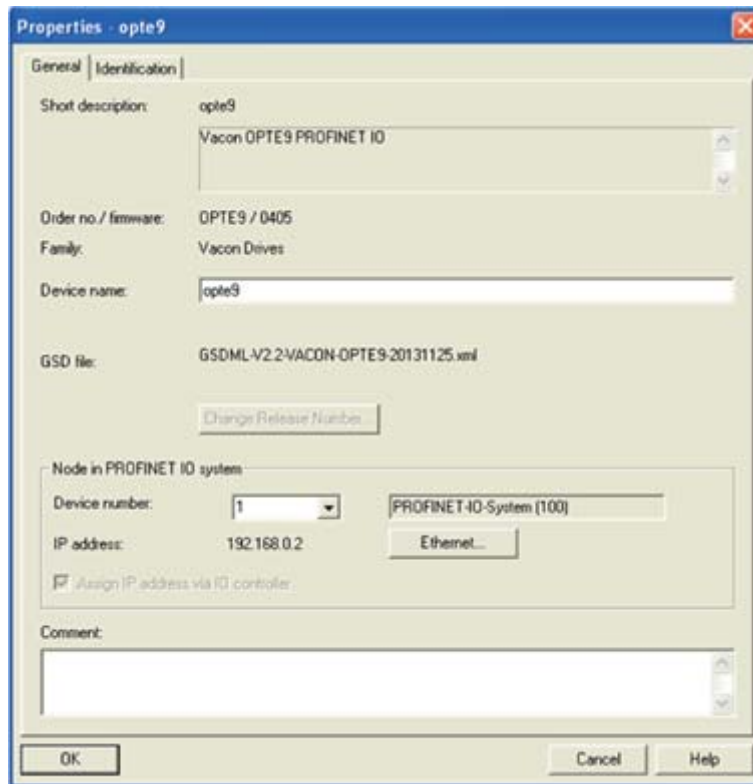

11625_00

14. Verify the Device Name.

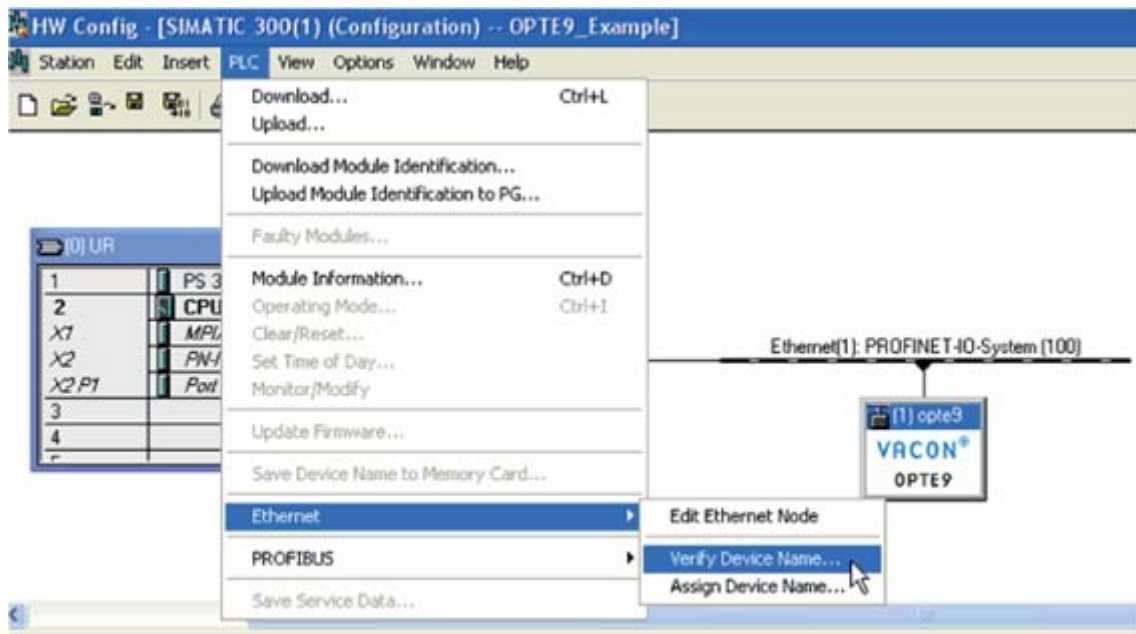

11626_00

15. Close the window.

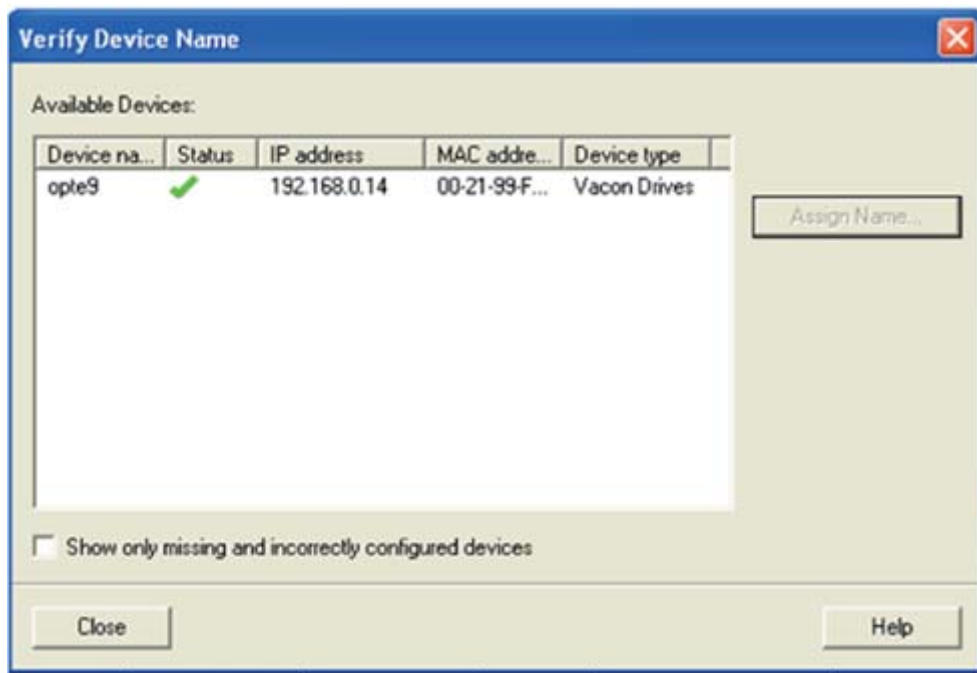

11627_00

16. Set the IO cycle. See Chapter 8.5 for details.

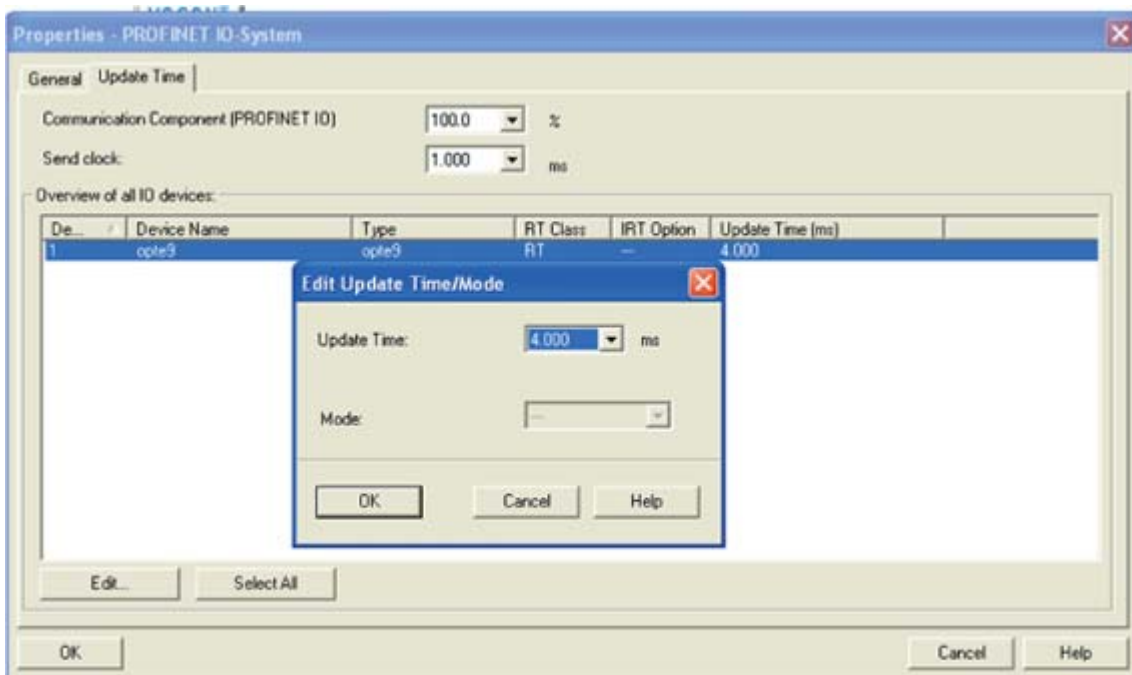

11628_00

13.2 SIEMENS TIA PORTAL

This example shows how to configure the Siemens S7-300 PLC series to use the VACON® OPTE9 option board with the Siemens TIA Portal programming tool. Check your individual PLC information. The information used in this example probably differs from the one you have.

1. Create a new project.

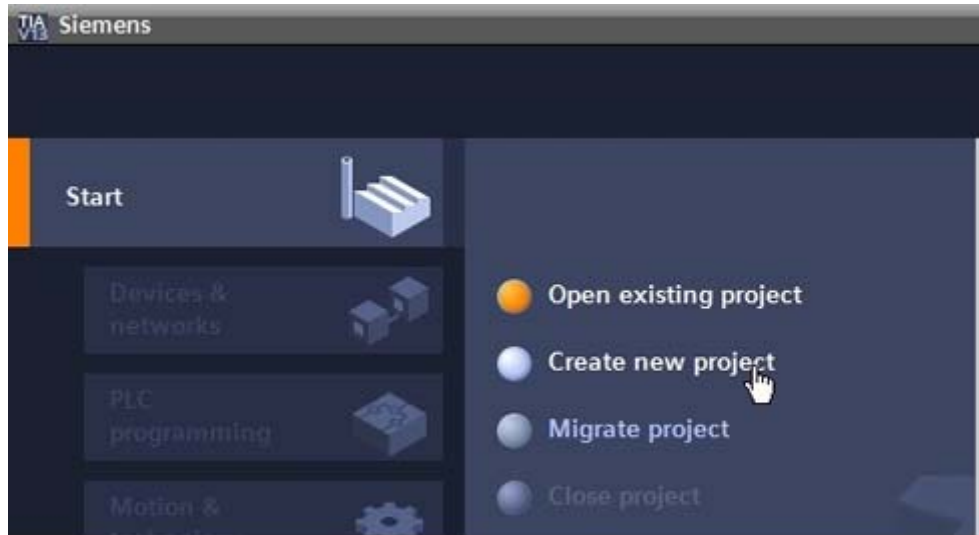

11756_00

2. Give the project a name and location and click "Create". When the project is created, click "Project View" from the lower left corner of the screen.

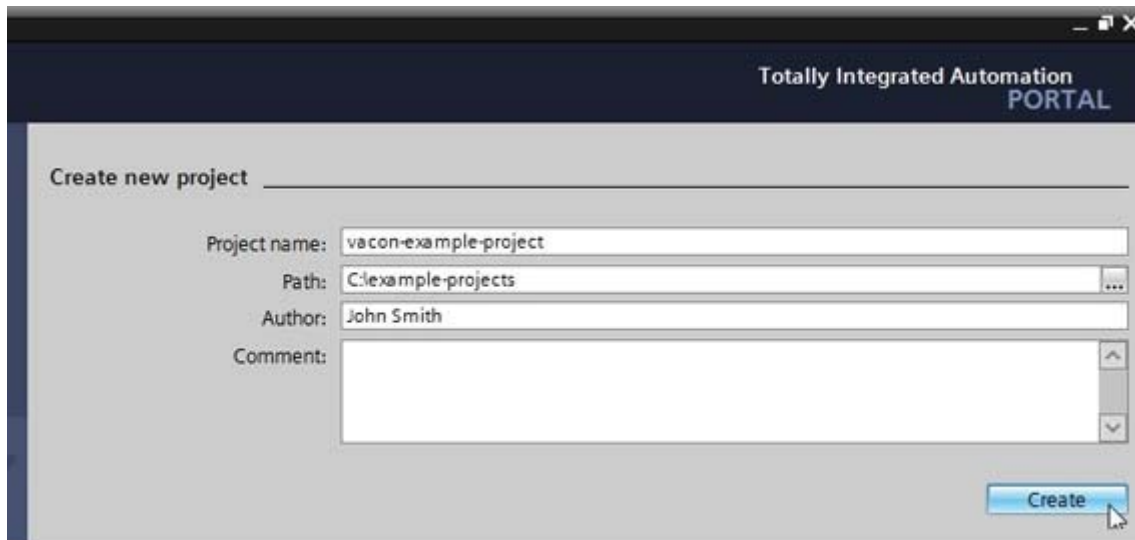

11757_00

3. Double-click on “Devices & networks”.

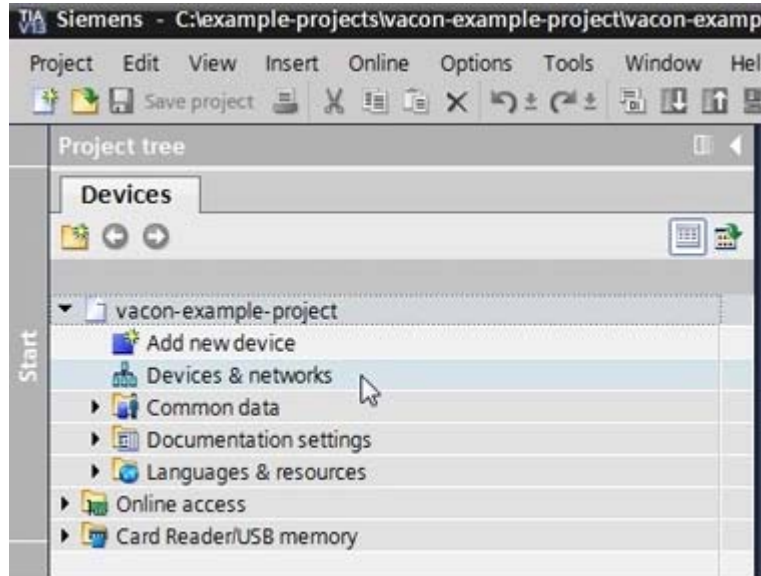

11758_00

4. Drag and drop the PLC you are using.

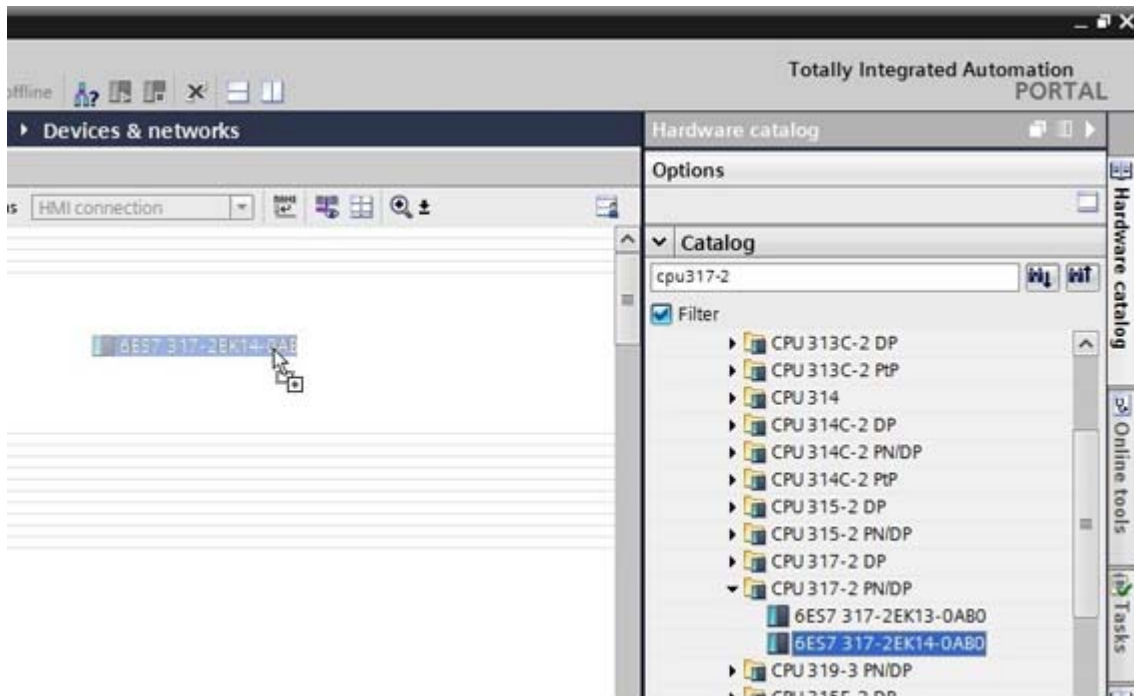

11759_00

5. Add option board.

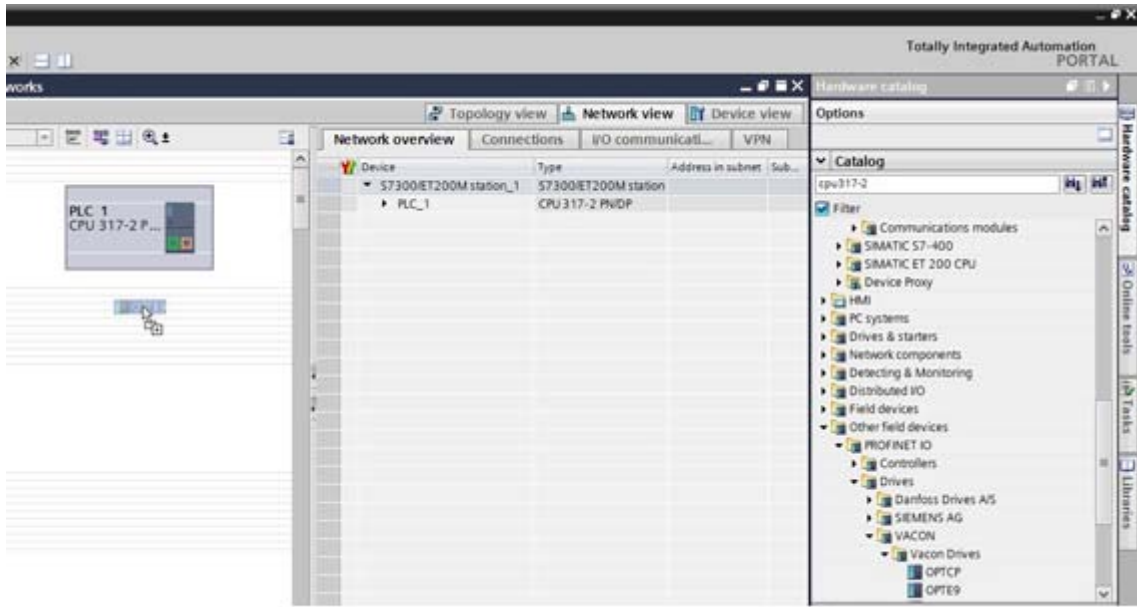

11785_00

6. Click the blue text "Not assigned" to assign IO controller.

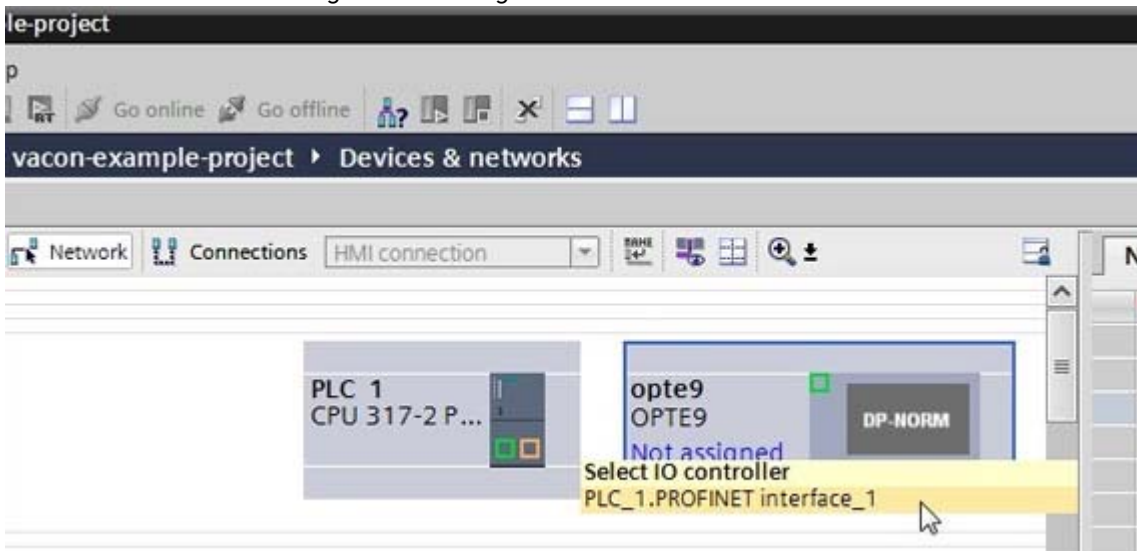

11835_00

7. Assign the connections between the Ethernet ports in "Topology view".

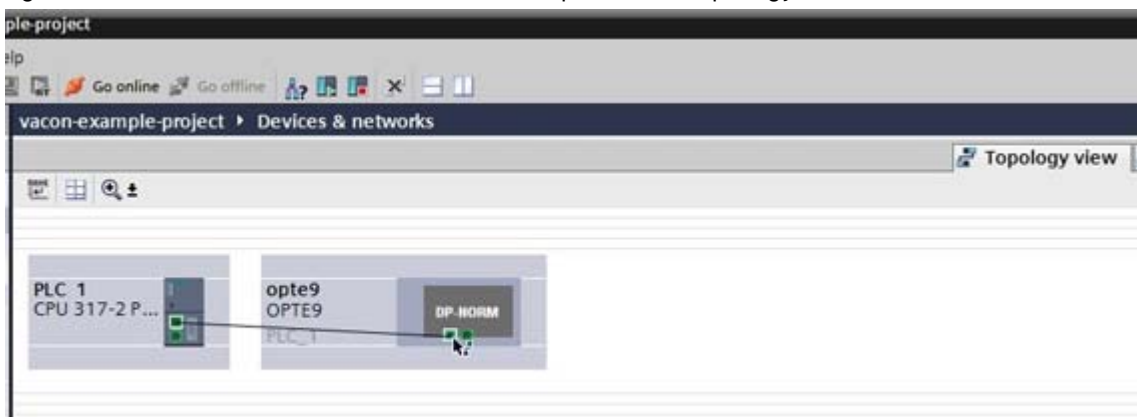

11786_00

8. Assign IP settings and Name of Station to the option board.

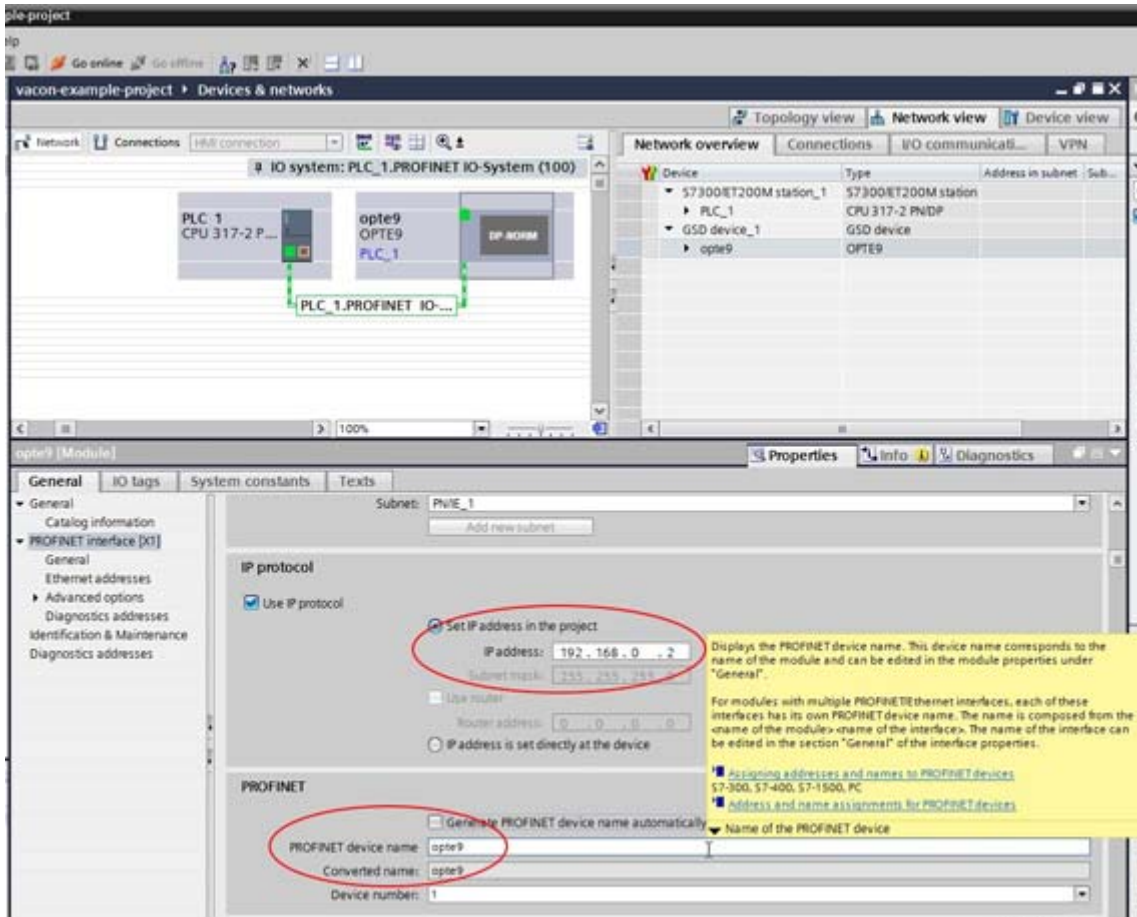

11787_00

9. Double-click on the OPTE9 to open the device view.

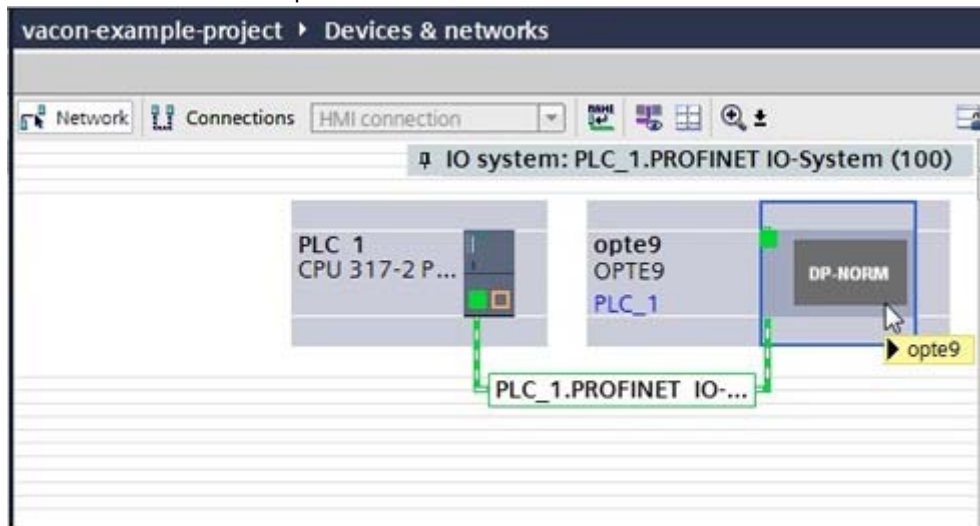

11788_00

10. Drag and drop the used telegram to the configuration.

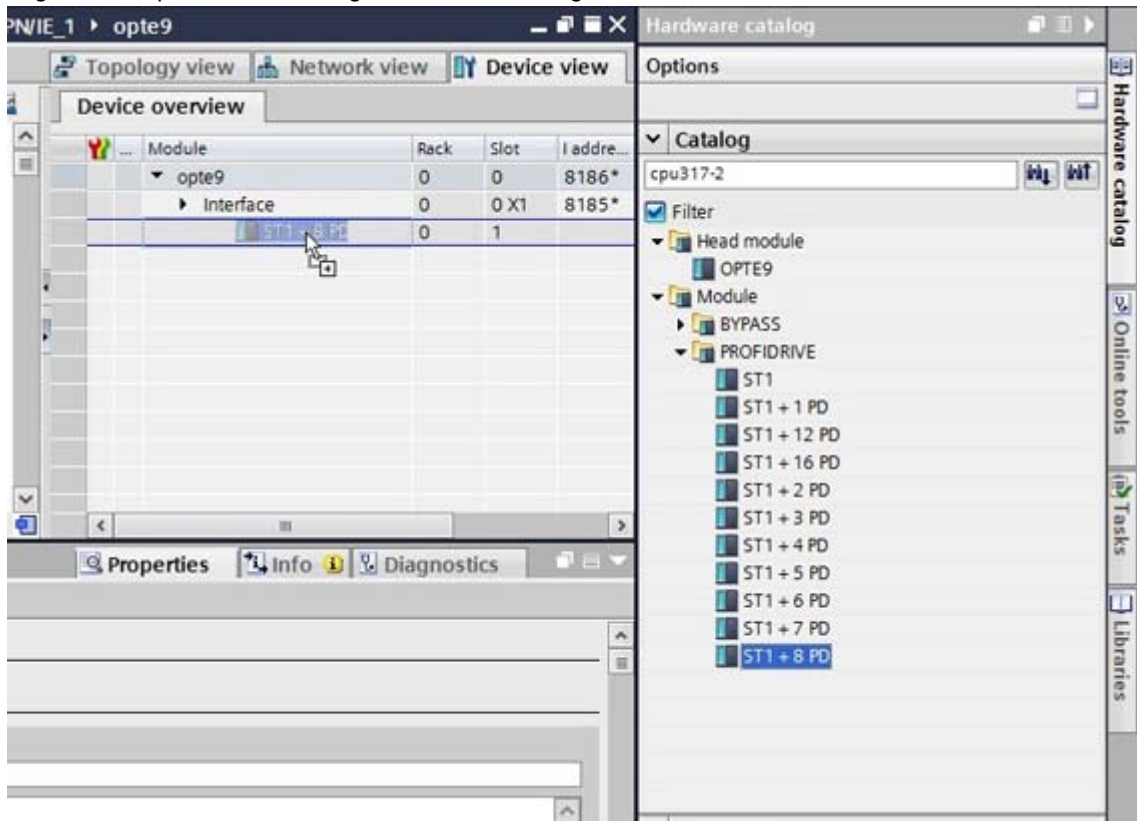

11789_00

11. The configuration is complete. Follow the next steps to load the configuration to the PLC.

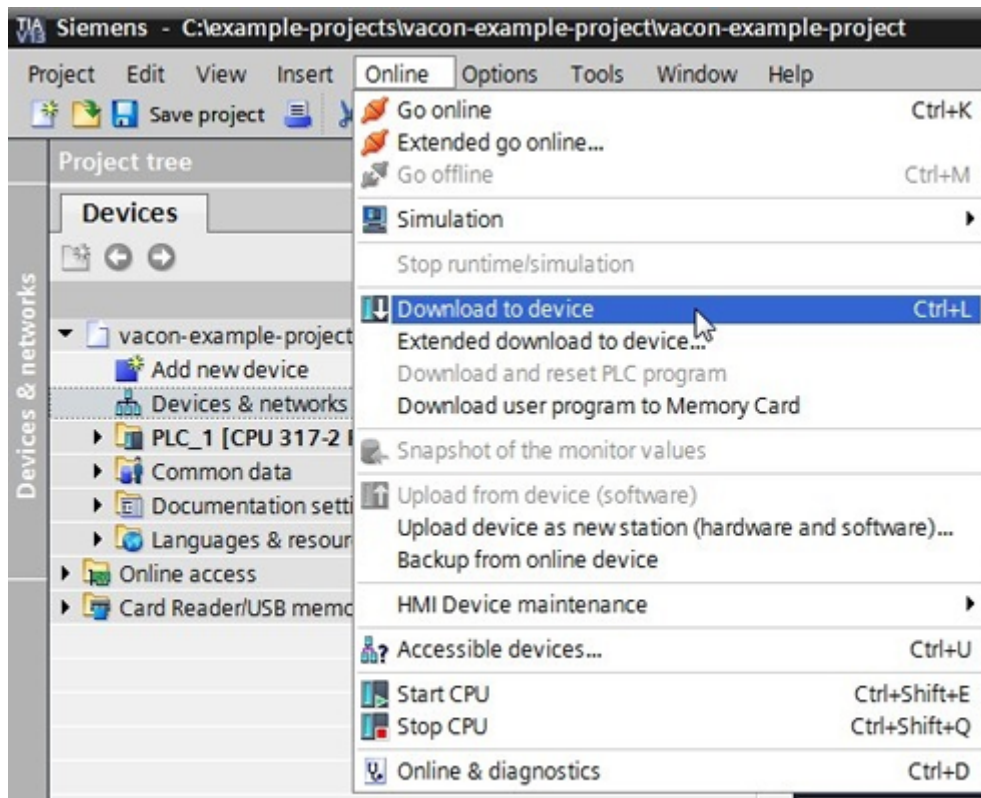

11766_00

12. Select the connection interface from the dropdown menu (how the PC with TIA Portal is connected to network with the PLC). Then click search. When the search is completed you should see your PLC in the list. Select it and click Load.

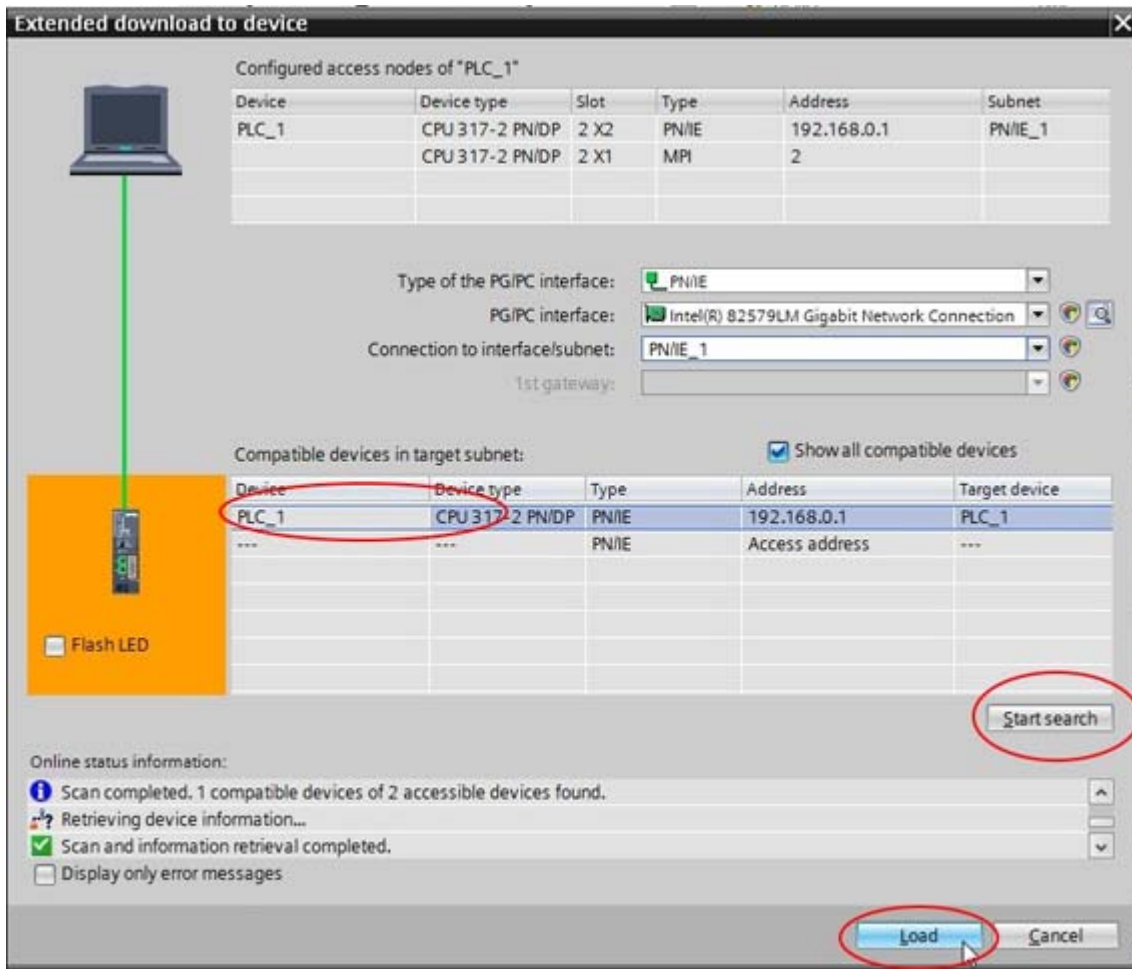

11767_00

13. TIA portal compiles the program.



11768_00

14. Click Load to load the program to the PLC.

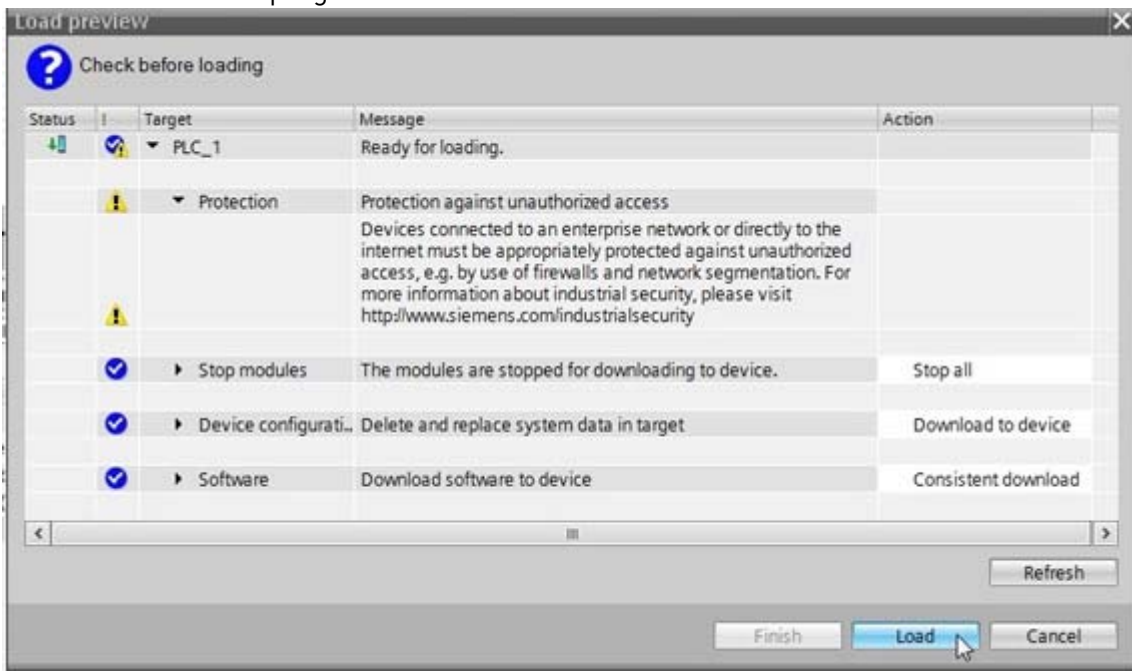

11769_00

15. When the loading is ready, click Finish. Now the PLC should start communicating with the option board.

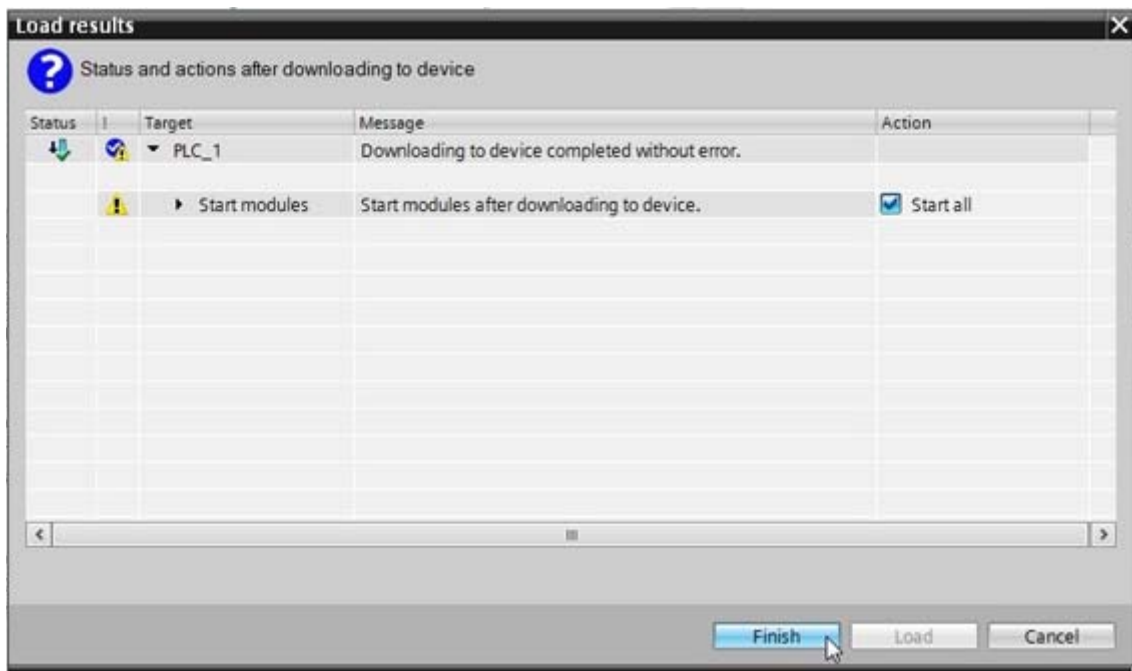

11770_00

14. APPENDIX 4 - EXAMPLE WITH SIEMENS SIMATIC PDM

The EDD files for Siemens SIMATIC PDM can be downloaded from:

<http://drives.danfoss.com/services/software-downloads/> -> VACON FIELDBUS CONFIGURATIONS

1. Use Device Integration manager to import the OPTE9 Dual Port Ethernet option board's EDD file.

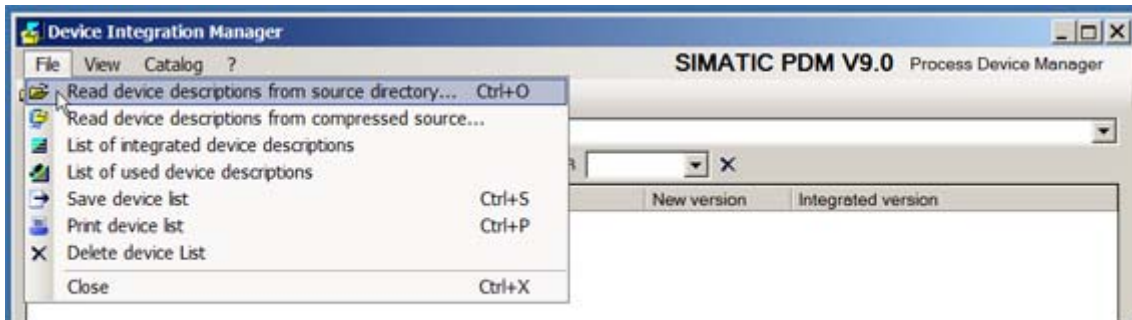

11730_uk

2. Select the folder that contains the correct EDD file for your AC drive and application.

3. Click the "Integration" button. Now, you can see a green check mark for the OPTE9 Dual Port Ethernet EDD file.

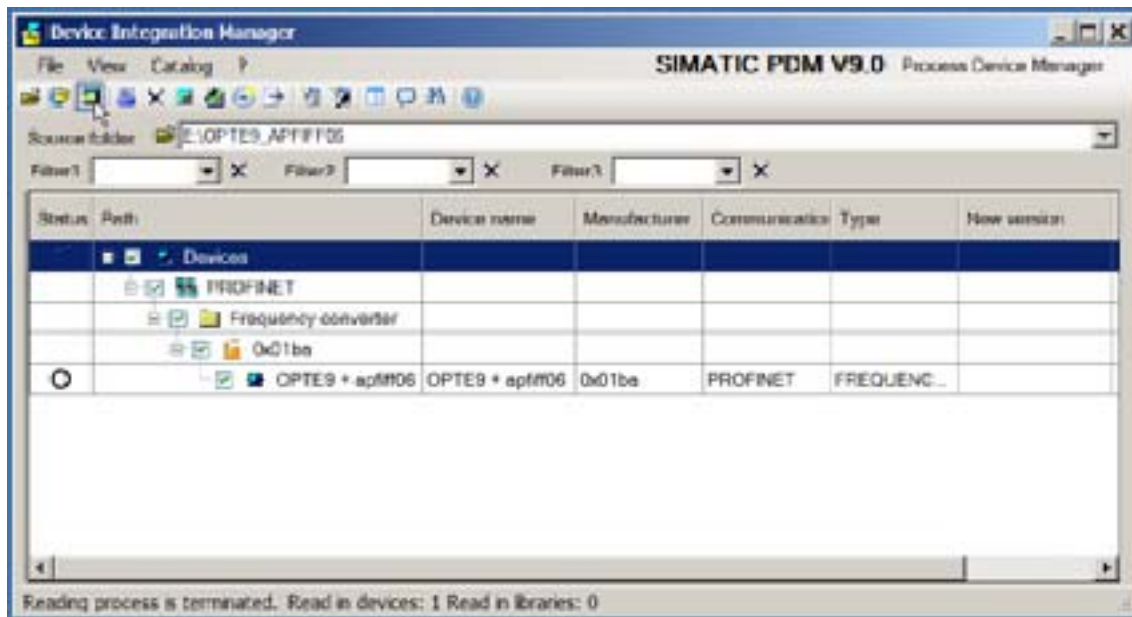

11731_uk

4. Insert the OPTE9 device into the network by selecting "Insert New Object" -> "Object".

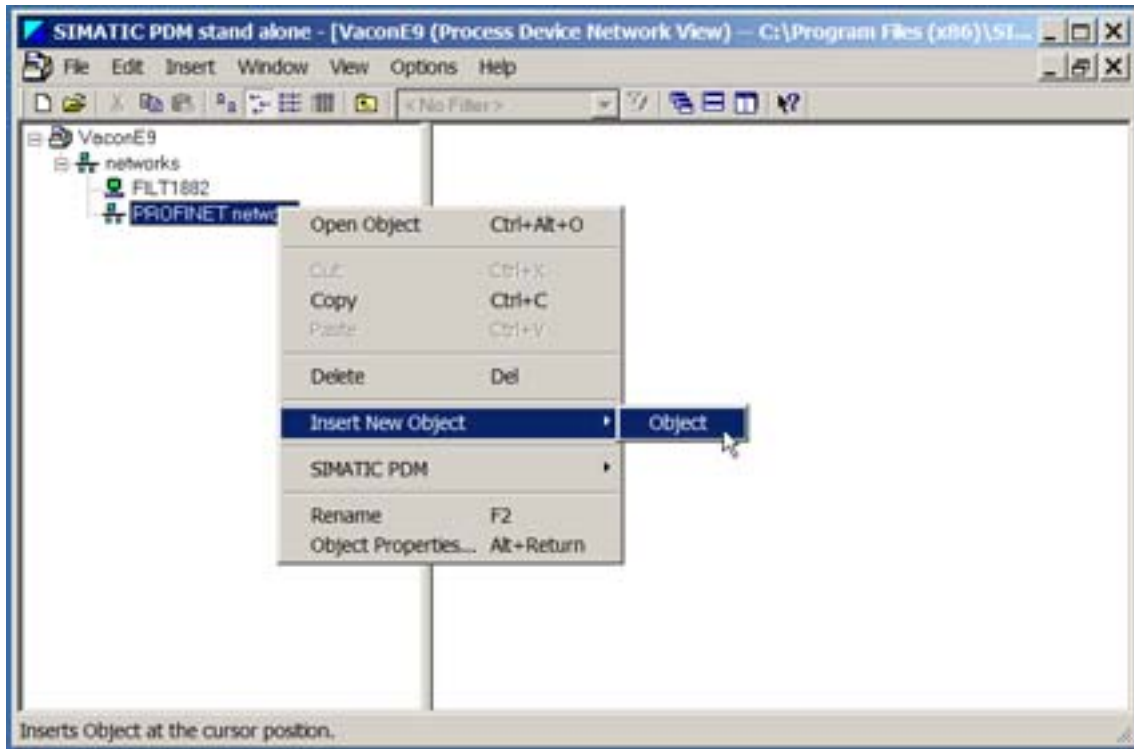

11732_uk

5. Enter the correct IP address for the OPTE9 Dual Port Ethernet option board. Currently used IP address can be seen from the monitor values. See Chapter 6.1.2 "Option board monitoring values".

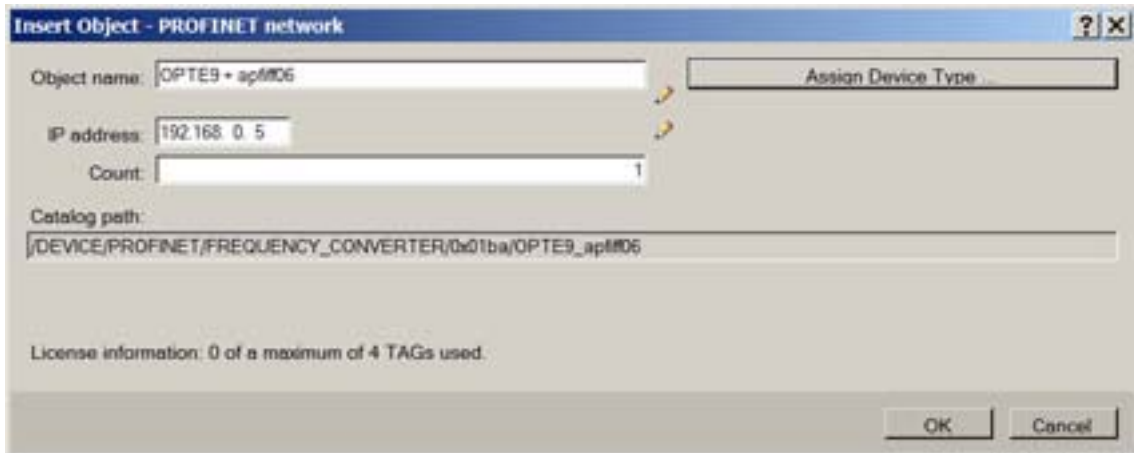

11733_uk

6. Now it is possible to load or restore parameters from/to AC drive.

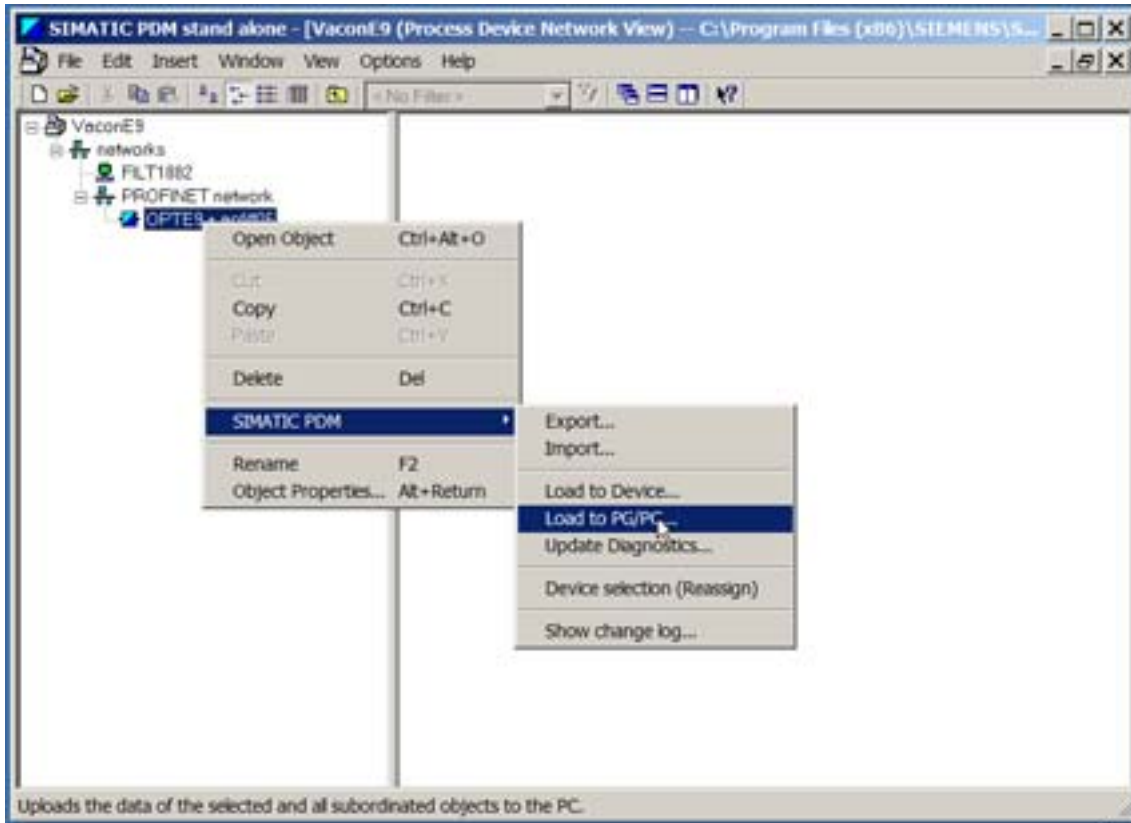

11734_uk

7. Parameters can be accessed by selecting "Open Object".

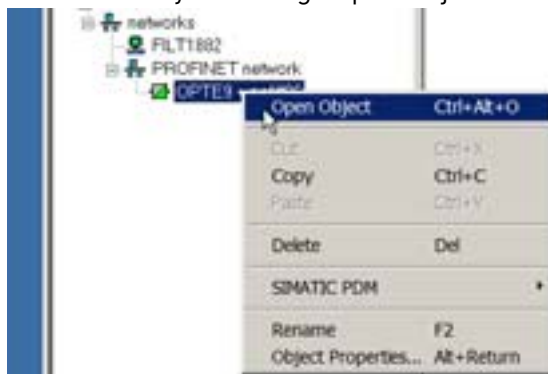

11735_uk

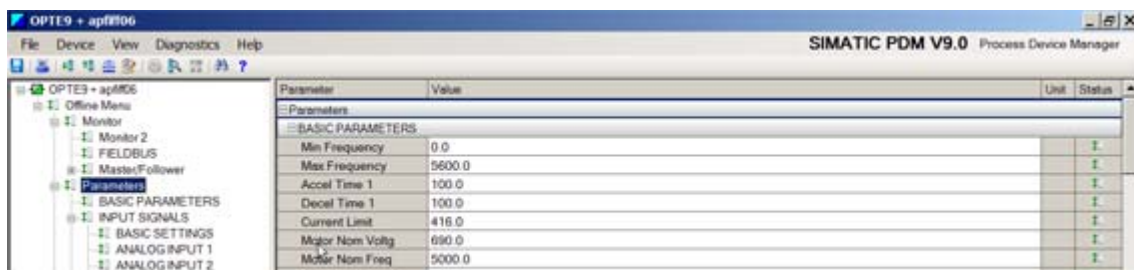

11736_uk

8. Values can be monitored real time by selecting "Device" -> "Online".

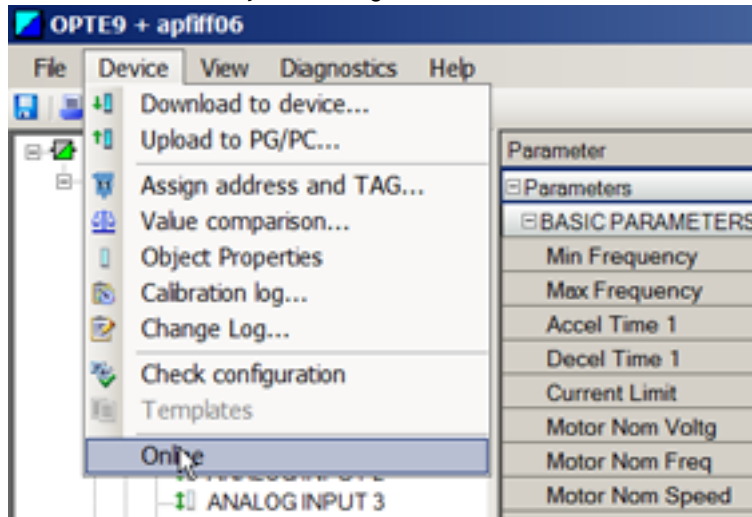

11737_uk



11738_uk

15. APPENDIX 5 - FIELD BUS PARAMETRISATION

The following chapter describes briefly how to parametrise the AC drive in order for the motor to be controllable via fieldbus. These instructions are written for basic applications. For more information, consult the application-specific manual.

In order for the AC drive to accept commands from the fieldbus network, the control place of the AC drive has to be set to fieldbus. The default value of the parameter "Control Place" is usually I/O. Note that if the control unit firmware is updated, the default settings are restored. In addition, some applications may have the remote speed reference selection set by default to other than fieldbus. In these cases, the speed reference selection must be set to fieldbus, in order for the speed reference to be controlled via fieldbus.

NOTE! The motor control mode should be selected to support the used process and profile.

15.1 FIELD BUS CONTROL AND BASIC REFERENCE SELECTION

The following tables list some of the parameters related to fieldbus control in case of VACON® applications for the VACON® 100 family, VACON® 20 / 20X and VACON® NXP. See the application specific manuals for more detailed information.

Parameters can be read and written by using the drive panel, PC Tools or fieldbus protocol. The table below contains links to chapters where the ID value reading is described.

Table 196. Links to ID value descriptions

Protocol	Chapter
Modbus	See Chapter "7.3.2.5.1. VACON® application IDs" See Chapter "7.3.2.5.4. ID map"
Profinet IO	See Chapter 8.4.7 "Drive parameter access using application ID"
EtherNet/IP	See Chapter 9.2.2.1 "Vendor Parameters Object, Class 0xA0"

Table 197. Parametrization for VACON® 100 (standard application)

Parameter name	ID	Value	Default	Panel Tree
Control mode	600	0 = Frequency 1 = Speed 2 = Torque	0	P 3.1.2.1
Remote control place	172	1 = Fieldbus CTRL	0	P 3.2.1
Local / remote	211	0 = Remote	0	P 3.2.2
Fieldbus ref. sel.	122	3 = Fieldbus	3	P 3.3.1.10
Controlling fieldbus	2539	-	1	P5.13.1

Table 198. Parametrization for VACON® 20 (standard application)

Parameter name	ID	Value	Default	Panel Tree
Motor control mode	600	0 = Frequency 1 = Speed	0	P 1.8
Rem. Control place 1 sel.	172	1 = Fieldbus CTRL	0	P 2.1
Local / remote	211	0 = Remote	0	P 2.5

Table 198. Parametrization for VACON® 20 (standard application)

Parameter name	ID	Value	Default	Panel Tree
Rem. Control place 1 freq. ref. sel.	117	3 = Fieldbus	7	P 3.3

Table 199. Parametrization for VACON® 20X (standard application)

Parameter name	ID	Value	Default	Panel Tree
Motor control mode	600	0 = Frequency 1 = Speed	0	P 8.1
Control place selection	125	2 = Fieldbus	0	P 1.11
Local / remote	211	0 = Remote	0	P 3.2.2
Frequency ref. sel.	1819	5 = Fieldbus	5-7	P 1.12

Table 200. Parametrization for VACON® NXP (multipurpose application)

Parameter name	ID	Value	Default	Panel Tree
Motor control mode	600	0 = Frequency 1 = Speed 2 = Torque	0	P 2.6.1
Control place selection	125	3 = Fieldbus	1	P 3.1
Fieldbus Ctrl Ref.	122	9 = Fieldbus	3	P 2.1.13

15.2 CONTROLLING FIELD BUS PARAMETER

Use the "Controlling Fieldbus"-parameter to select the instance from which the process data is sent to the drive application. By default the setting is in "Automatic" and the functionality (when receiving process data from multiple sources) is application dependent.

For example, if the option board has been installed to slot E and it is used with PROFINET to control the drive, user can select "Slot E" as value for this parameter. Now only the process data from the option board in slot E is forwarded to the application. All other fieldbusses will still receive process data out. With this setting it is possible to prevent that the monitoring fieldbusses accidentally write process data in.

Table 201.

Value name	Value	Description
Automatic	1	Process data from all sources is forwarded to application
Slot D	2	Only process data from slot D is forward to application. Value is visible only, if option board is installed to slot D.
Slot E	3	Only process data from slot E is forward to application. Value is visible only, if option board is installed to slot E.
RS485	4	Only process data from VACON® 100 family internal RS 485 protocol is forwarded to application

Table 201.

Value name	Value	Description
PROFINET IO	5	Only process data from VACON® 100 family internal PROFINET IO protocol is forwarded to application
EtherNet/IP	6	Only process data from VACON® 100 family internal EtherNet/IP protocol is forwarded to application
Modbus TCP/UDP	7	Only process data from VACON® 100 family internal Modbus TCP/UDP protocol is forwarded to application
Bacnet IP	8	Only process data from VACON® 100 family internal Bacnet IP protocol is forwarded to application

15.3 TORQUE CONTROL PARAMETRIZATION

Some extra parametrisation has to be made in order to control the frequency control with torque control. The following instructions are for the VACON® 100 family and VACON® NXP application, see the application-specific manual for more detailed information.

- Motor control mode (ID 600) should be configured to "Torque control" (2).

To configure the drive to use correct torque reference, select the parameter "Torque Reference Selection" to ProcessDataIn1 (9). This can be done with:

- PC-tool or panel (VACON® 100 family: P 3.3.2.1, VACON® NXP: P 2.10.4) / ID 641
- Vendor Parameter Object

16. APPENDIX 6 - LWIP LICENCE

License for LWIP

Copyright (c) 2001, 2002 Swedish Institute of Computer Science.

All rights reserved.

Redistribution and use in source and binary forms, with or without modification, are permitted provided that the following conditions are met:

- 1.Redistributions of source code must retain the above copyright notice, this list of conditions and the following disclaimer.
- 2.Redistributions in binary form must reproduce the above copyright notice, this list of conditions and the following disclaimer in the documentation and/or other materials provided with the distribution.
- 3.The name of the author may not be used to endorse or promote products derived from this software without specific prior written permission.

THIS SOFTWARE IS PROVIDED BY THE AUTHOR "AS IS" AND ANY EXPRESS OR IMPLIED WARRANTIES, INCLUDING, BUT NOT LIMITED TO, THE IMPLIED WARRANTIES OF MERCHANTABILITY AND FITNESS FOR A PARTICULAR PURPOSE ARE DISCLAIMED. IN NO EVENT SHALL THE AUTHOR BE LIABLE FOR ANY DIRECT, INDIRECT, INCIDENTAL, SPECIAL, EXEMPLARY, OR CONSEQUENTIAL DAMAGES (INCLUDING, BUT NOT LIMITED TO, PROCUREMENT OF SUBSTITUTE GOODS OR SERVICES; LOSS OF USE, DATA, OR PROFITS; OR BUSINESS INTERRUPTION) HOWEVER CAUSED AND ON ANY THEORY OF LIABILITY, WHETHER IN CONTRACT, STRICT LIABILITY, OR TORT (INCLUDING NEGLIGENCE OR OTHERWISE) ARISING IN ANY WAY OUT OF THE USE OF THIS SOFTWARE, EVEN IF ADVISED OF THE POSSIBILITY OF SUCH DAMAGE.

17. APPENDIX 7 - FIELDBUS OPTION BOARD COMMUNICATION

The different communication modes can be enabled for fieldbus option board for different features. There are different modes available for different setups:

- Normal mode, for most commonly used setups. 8 process data items.
- Normal extended mode, for setups that require 16 process data items.
- Fast mode, with low latency process data. 16 process data items.
- Fast safety mode, with safety "black channel". 16 process data items.
- Fast PROFIBUS mode, for backward compatibility. 8 process data items.

NOTE! The OPTE9 Dual Port Ethernet does not support the following modes: Fast Safety mode and Fast PROFIBUS mode.

The fast communication modes can be enabled to get minimum communication delay between fieldbus and application.

17.1 REQUIREMENTS FOR COMMUNICATION MODES

The following table describes the required components for different communication modes:

Table 202. Requirements for different fieldbus communication modes

	Fast / Normal Extended	Fast PROFIBUS
Control Board	NXP (serial no. 761 or later)	NXP (serial no. 561 or later)
System Software	NXP00003V196.VCN or later NXPSAFEV007 special firmware	NXP00002V171.VCN or later
		NXP00003V179.VCN or later
Applications	Advanced V085 or later Multipurpose V236 or later (Normal Extended Mode)	System Interface V110 or later
		Advanced V085 or later
		Marine V107 or later
Fieldbus option slot	OPTE3-E5_FW0083V006.vcx or later	OPTC3_10502V014.vcn or later
	OPTE9_FW0196V007.vcx or later	OPTC3-5_FW0232V001.vcx or later
	OPTEC in future	OPTEC_FW0128V001.vcx or later

Refer to application specific manuals for latest information about application support for fieldbus communication modes.

17.2 FIEDLBUS COMMUNICATION MODE FEATURES AND LIMITATIONS

Fast mode:

- 1 ms process data interval
- Available in VACON® NXP slots D and E
 - Possible to run both slots simultaneously
 - Have similar process data latency in both slots
- Service data latency is also reduced
 - Running multiple service data queries at high interval can cause high CPU load in VACON® NXP AC drive.

16 process data items:

- 16 process data items always require support from application
- Available in both Fast mode and Normal Extended mode
- If no support is available the process data out shall always be '0', while incoming process data items 9-16 are discarded

17.3 NORMAL FIELDBUS COMMUNICATION

The normal fieldbus communication between option board and the AC drive application is visible in Figure 49. In normal communication both process data and service data are transferred in succession at 5 ms interval.

Communication delay for process data can be calculated by summing all delays together:

$$t = t_{IOdatacycle} + t_{updateinterval} + 2 \cdot t_{communicationdelay} + t_{applicationcycle}$$

Example: With fieldbus cycle time of 4 ms and application cycle of 10 ms, the delay is:

$$t = 4ms + 10ms + (2 \cdot 5)ms + 10ms = 34ms$$

NOTE: This value does not include delays of the fieldbus master, jitter in the process data cycle of the communication protocol or resending due to electronic interference.

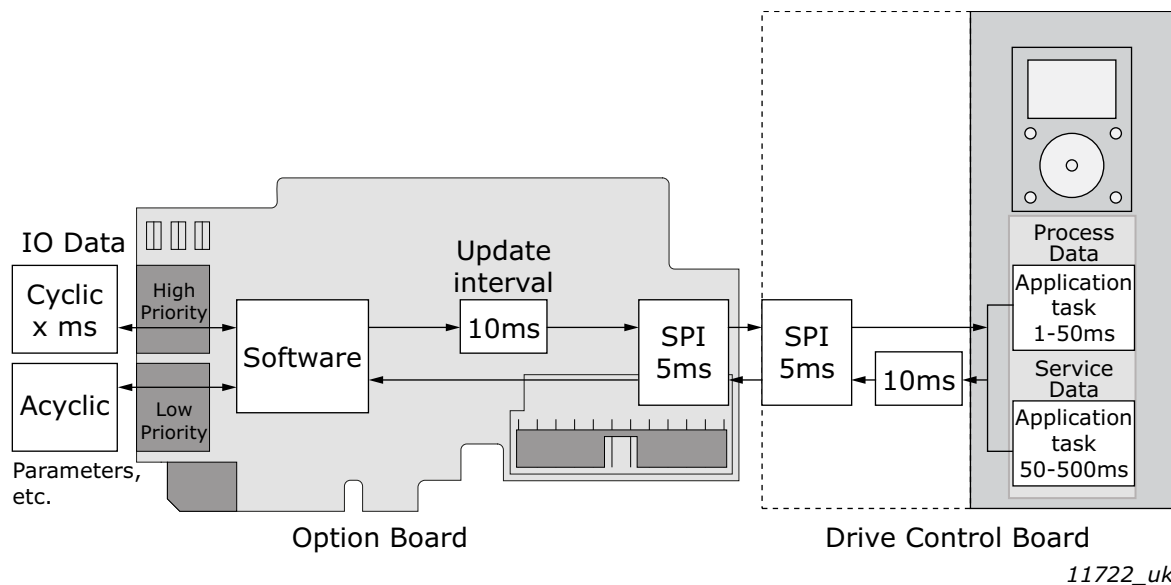

Figure 49. Normal fieldbus communication

11722_uk

17.4 FAST FIELDBUS COMMUNICATION

The fast mode decreases the communication delay between the PLC and the AC drive application significantly by using two communication channels separately for process and service data. The process data interval is set to 1 ms, while other data is sent acyclically. When the fast mode is activated, the application can be synchronized to run with the communication cycle. The Fast communication mode is visible in Figure 50. This mode also includes the ability to transfer 16 process data items.

The communication delay for process data in fast communication mode is (when application task is synchronized with communication):

$$t = t_{IOdata\ cycle} + t_{update\ interval} + t_{application\ cycle}$$

Example: With fieldbus cycle time of 1 ms an application cycle of 1 ms the delay is::

$$t = 1\ ms + 1 + 1\ ms = 3\ ms$$

NOTE: This value does not include delays of the fieldbus master, jitter in the process data cycle of the communication protocol or resending due to electronic interference.

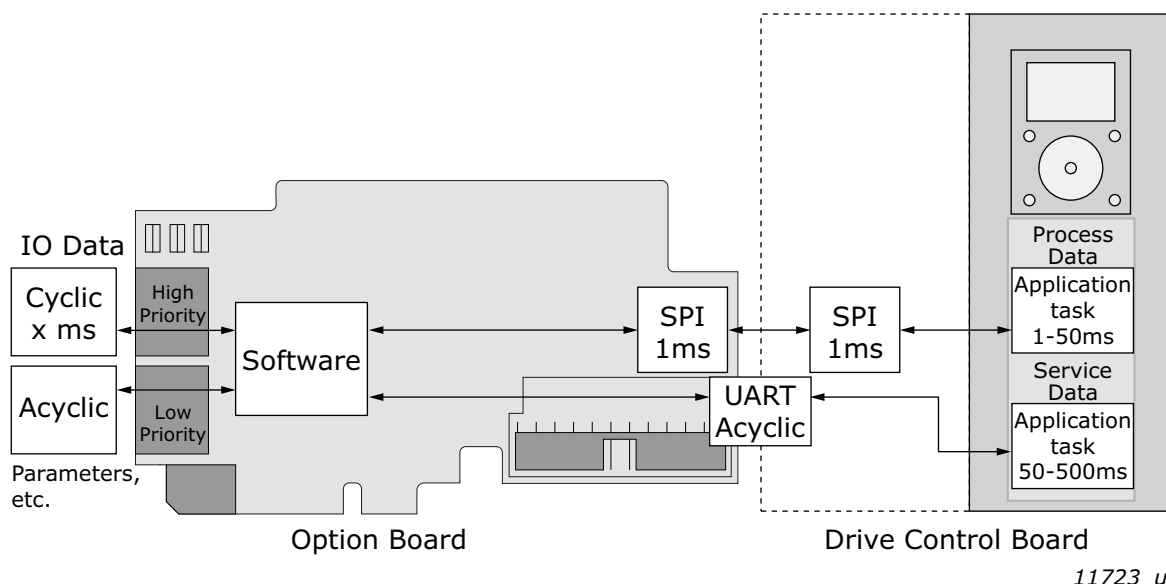

Figure 50. Fast fieldbus communication

17.5 NORMAL EXTENDED MODE

The normal extended mode uses the same communication method that is used in "Fast mode", but reduces the communication cycle to 5ms. Therefore, the communication delay is still faster than in "Normal mode".

This mode can be used in applications where 16 process data items are required but the lowest possible communication delay is not needed or the increased CPU load of Fast mode to VACON® NXP AC drives is problematic.

NOTE: This mode is automatically enabled in VACON® Applications supporting 16 process data items.

18. APPENDIX 8 - PARAMETERS FOR APPLICATION DEVELOPERS

This appendix gives information for the application developers and system integrators on the VACON[®] NXP system software variables used to activate and control different fieldbus communication modes and features.

NOTE! Changing of mode while running the motor is not supported because of security reasons.

Table 203. System software variables for selecting communication modes

Parameter	Value	Default
FBModeSlotD_fwu8	0 = Normal mode	0
FBModeSlotE_fwu8	1 = Fast safety mode* 2 = Fast mode 3 = Fast PROFIBUS mode** 4 = Normal extended mode	0

* Fast safety mode is automatically enabled/disabled by system software. Cannot be set by user. This mode is not supported in OPTE9 Dual Port Ethernet.

** Fast PROFIBUS mode is not supported in OPTE9 Dual Port Ethernet.

FBModeSlotX_fwu8 variables are used to select the active fieldbus option board communication mode. If no fieldbus option board is connected to the related slot, the selection of the FBModeSlot parameter is set to 0 = Normal mode.

Table 204. System software variables for monitoring supported communication modes

Parameter	Value	Default
FBModeSlotDSupModes_fwu16	0x00 = Not yet updated. Read again later 0x01 = Fieldbus communication not supported 0x02 = Normal mode supported 0x04 = Fast safety mode supported	0
FBModeSlotESupModes_fwu16	0x08 = Fast mode supported 0x10 = Fast PROFIBUS mode supported 0x20 = Normal extended mode supported	0

FBModeSlotXSupModes_fwu16 variables can be used to determine the different supported modes of the fieldbus option boards. All features are set as bit fields as multiple modes can be supported.

Value '0' is returned while the feature set of the option board is not yet retrieved. Value should be asked again. Any option board not supporting fieldbus communication shall return value '1'.

Example 1: OPTE3-E5_FW0083V006 PROFIBUS board returns value: 0x0E, indicating support for Normal, Fast and Fast safety modes.

Example 2: OPTE9_FW0196V006 Dual Port Ethernet board returns value: 0x0A, indicating support for Normal and Fast modes.

Table 205. System software variables for selecting the input process data slot

Parameter	Value	Default
FBControlSlotSelector_fwu8	0 = All slots 4 = Slot D only 5 = Slot E only 6 = Fast PROFIBUS D slot* 7 = Fast PROFIBUS E slot*	0

* Fast PROFIBUS mode is not supported in OPTE9 Dual Port Ethernet.

FBControlSlotSelector_fwu8 variable is used to select the controlling fieldbus option board slot. When selected (other than '0'), process data is accepted only from the selected slot and all other process data is discarded. Process data out is still updated normally to all slots.

This selector can be used to support redundant fieldbus connection. In fieldbus redundancy mode two fieldbus option boards are installed to VACON[®] NXP option board slots D and E. Application selects with FBControlSlotSelector_fwu8 variable which fieldbus option board can deliver process data from fieldbus master to the application.

Default value for FBControlSlotSelector_fwu8 is '0' which means that process data is accepted from both fieldbus option boards.

VACON[®]

www.danfoss.com

Vacon Ltd
Member of the Danfoss Group
Runsorintie 7
65380 Vaasa
Finland

Document ID:



DPD01583E

Rev. E

Sales code: DOC-OPTE9+DLUK