

VACON[®]
AC DRIVES

OPTEC
ETHERCAT OPTION BOARD
INSTALLATION MANUAL

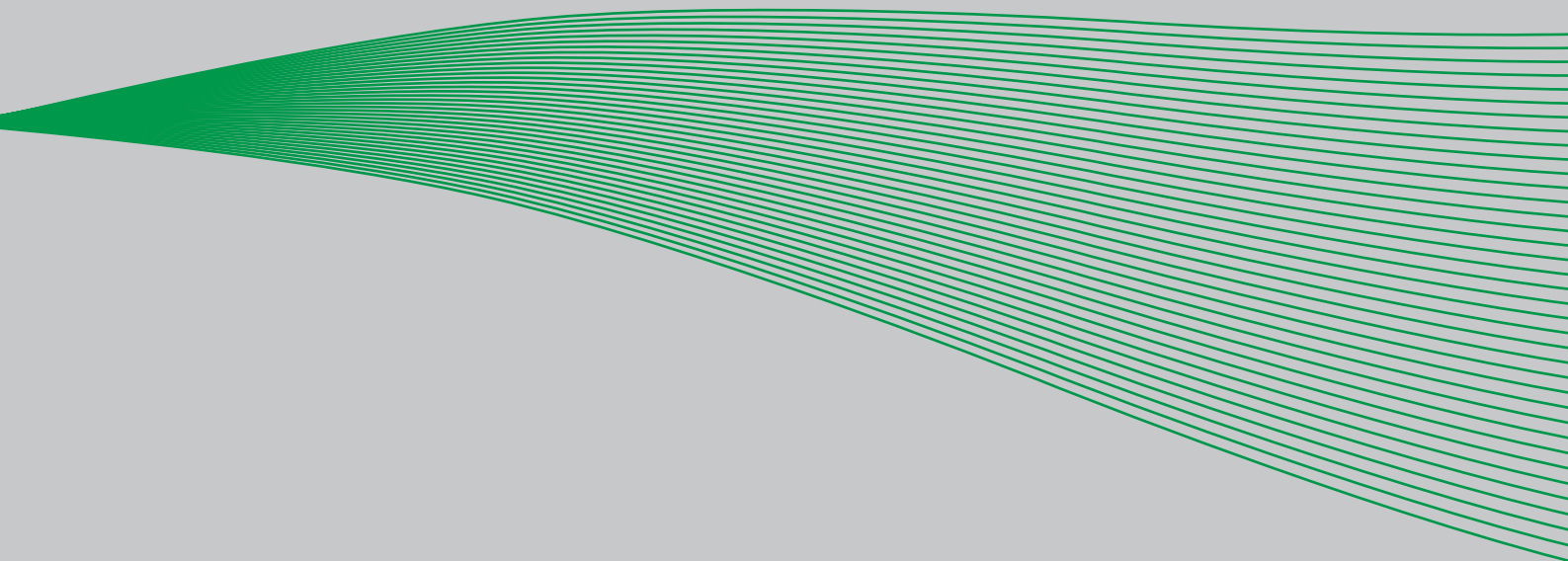

VACON[®]
DRIVEN BY DRIVES

TABLE OF CONTENTS

Document: DPD01207B

Release date : 12/11/14

1.	Safety	3
1.1	Danger	3
1.2	Warnings	4
1.3	Earthing and earth fault protection	5
2.	OPTEC EtherCAT - General	6
3.	EtherCAT option board technical data	8
3.1	General	8
3.2	Cables	8
4.	Layout and connections	9
4.1	Layout and connections	9
4.2	LED Indications	10
4.3	Topologies	12
4.4	Connecting the board in line topology	13
5.	Installation	14
5.1	Installation in Vacon® NXP	14
5.2	Installation in Vacon® 20.....	17
5.2.1	Frames MI1, MI2, MI3	17
5.2.2	Frames MI4, MI5	19
5.3	Installation in Vacon® 100.....	22
6.	Commissioning	25
6.1	Supported drives	25
6.2	OPTEC board Parameters.....	25
6.3	Updating the firmware of OPTEC option board with Vacon Loader	26
6.4	Establishing a connection to EtherCAT bus	28
6.5	Writing and reading Process Data	32
6.5.1	Writing Data Object value to OPTEC option board.....	32
6.5.2	Reading Data Object values from OPTEC option board.....	33
6.6	Switching operating modes	34
6.6.1	Switching to Bypass mode	34
6.6.2	Switching to CiA-402 Mode	36
6.7	Controlling the Motor in CiA-402 Mode	39
6.8	Controlling the Motor in Bypass Mode	40
6.9	EtherCAT Slave Information (ESI) File.....	41
6.9.1	OPTEC ESI File	41
6.9.2	Using TwinCAT	41
6.9.3	Using the online description	41
6.10	ESI file selection.....	42
6.10.1	ESI file selection mode	42
7.	EtherCAT	46
7.1	Data object list	46
7.2	Data Object Descriptions	52
7.2.1	RxPDO assign	52
7.2.2	TxPDO assign	53
7.2.3	Sync Manager	53
7.2.4	Drive Information	54
7.2.5	ESI File Selection Mode	54
7.2.6	Operating Energy Counters	55
7.2.7	Operating Trip Time Counters	55
7.2.8	Operating Time Counters.....	56

7.2.9	Parameter Channel Read	57
7.2.10	Parameter Channel Write	57
7.2.11	Bypass Control	58
7.2.12	Bypass status	60
7.2.13	Bypass Speed SetPoint Value	61
7.2.14	Bypass Speed Actual Value	61
7.2.15	Process Data In	61
7.2.16	Process Data Out	62
7.2.17	CiA-402 Control Word	62
7.2.18	CiA-402 Status Word	62
7.2.19	CiA-402 vl Target Velocity	63
7.2.20	CiA-402 vl Velocity Demand	63
7.2.21	CiA-402 vl Velocity Actual Value	64
7.2.22	CiA-402 vl Velocity Min Max Amount	64
7.2.23	CiA-402 vl Velocity Acceleration	65
7.2.24	CiA-402 vl Velocity Deceleration	65
7.2.25	CiA-402 Modes of Operation Display	66
7.2.26	CiA-402 supported Drive Modes	66
7.3	OPTEC modes.....	68
7.3.1	CiA-402 mode	68
7.3.2	Bypass mode	71
7.3.3	NXP Fast Process Data Mode	72
7.4	Accessing drive parameters	73
7.4.1	Error codes.....	73
7.4.2	Example 1: Reading ID 103 'acceleration time' using the parameter channel	73
7.4.3	Example 2: Writing ID 103 'acceleration time' using the parameter channel.....	74
7.4.4	Example 3: Attempting to write an invalid value using the parameter channel	76
7.4.5	Example 4: Writing to parameter using CoE object list	77
8.	Appendix A: CANopen DS301 specific data object descriptions.....	78
8.1	Object 1001h: Error Register	79
9.	Appendix B: Device profile for drives	80



1. SAFETY

This manual contains clearly marked cautions and warnings that are intended for your personal safety and to avoid any unintentional damage to the product or connected appliances.

Please read the information included in cautions and warnings carefully.

The cautions and warnings are marked as follows:

Table 1. Warning signs

	= DANGER! Dangerous voltage
	= WARNING or CAUTION
	= Caution! Hot surface

1.1 DANGER



The **components of the power unit are live** when the drive is connected to mains potential. Coming into contact with this voltage is **extremely dangerous** and may cause death or severe injury.



The **motor terminals U, V, W and the brake resistor terminals are live** when the AC drive is connected to mains, even if the motor is not running.



After disconnecting the AC drive from the mains, **wait** until the indicators on the keypad go out (if no keypad is attached, see the indicators on the cover). Wait 5 more minutes before doing any work on the connections of the drive. Do not open the cover before this time has expired. After expiration of this time, use a measuring equipment to absolutely ensure that no voltage is present. **Always ensure absence of voltage before starting any electrical work!**



The control I/O-terminals are isolated from the mains potential. However, the **relay outputs and other I/O-terminals may have a dangerous control voltage** present even when the AC drive is disconnected from mains.



Before connecting the AC drive to mains make sure that the front and cable covers of the drive are closed.



During a ramp stop (see the Application Manual), the motor is still generating voltage to the drive. Therefore, do not touch the components of the AC drive before the motor has completely stopped. Wait until the indicators on the keypad go out (if no keypad is attached, see the indicators on the cover). Wait additional 5 minutes before starting any work on the drive.

1.2 WARNINGS



The AC drive is meant for **fixed installations only**.



Do not perform any measurements when the AC drive is connected to the mains.



The **earth leakage current** of the AC drives exceeds 3.5mA AC. According to standard EN61800-5-1, a **reinforced protective ground connection** must be ensured. See Chapter 1.3.



If the AC drive is used as a part of a machine, the **machine manufacturer is responsible** for providing the machine with a **supply disconnecting device** (EN 60204-1).



Only **spare parts** delivered by Vacon can be used.



At power-up, power brake or fault reset **the motor will start immediately** if the start signal is active, unless the pulse control for Start/Stop logic has been selected. Furthermore, the I/O functionalities (including start inputs) may change if parameters, applications or software are changed. Disconnect, therefore, the motor if an unexpected start can cause danger.



The **motor starts automatically** after automatic fault reset if the auto restart function is activated. See the Application Manual for more detailed information.



Prior to measurements on the motor or the motor cable, disconnect the motor cable from the AC drive.



Do not touch the components on the circuit boards. Static voltage discharge may damage the components.



Check that the **EMC level** of the AC drive corresponds to the requirements of your supply network.

1.3 EARTHING AND EARTH FAULT PROTECTION



CAUTION!

The AC drive must always be earthed with an earthing conductor connected to the earthing terminal marked with

The earth leakage current of the drive exceeds 3.5mA AC. According to EN61800-5-1, one or more of the following conditions for the associated protective circuit must be satisfied:

- a) The protective conductor must have a cross-sectional area of at least 10 mm² Cu or 16 mm² Al, through its total run.
- b) Where the protective conductor has a cross-sectional area of less than 10 mm² Cu or 16 mm² Al, a second protective conductor of at least the same cross-sectional area must be provided up to a point where the protective conductor has a cross-sectional area not less than 10 mm² Cu or 16 mm² Al.
- c) Automatic disconnection of the supply in case of loss of continuity of the protective conductor.

The cross-sectional area of every protective earthing conductor which does not form part of the supply cable or cable enclosure must, in any case, be not less than:

- 2.5mm² if mechanical protection is provided or
- 4mm² if mechanical protection is not provided.

The earth fault protection inside the AC drive protects only the drive itself against earth faults in the motor or the motor cable. It is not intended for personal safety.

Due to the high capacitive currents present in the AC drive, fault current protective switches may not function properly.



Do not perform any voltage withstand tests on any part of the AC drive. There is a certain procedure according to which the tests must be performed. Ignoring this procedure can cause damage to the product.

NOTE! You can download the English and French product manuals with applicable safety, warning and caution information from www.vacon.com/downloads.

REMARQUE Vous pouvez télécharger les versions anglaise et française des manuels produit contenant l'ensemble des informations de sécurité, avertissements et mises en garde applicables sur le site www.vacon.com/downloads.

2. OPTEC ETHERCAT - GENERAL

Vacon frequency converter can be connected to EtherCAT bus using the OPTEC fieldbus option board. The converter can access the data structures via the EtherCAT bus.

EtherCAT is a fieldbus protocol which uses standard Ethernet network as its media to transfer data structures between other EtherCAT devices in the bus. EtherCAT uses Master-Slave type communication. EtherCAT master device controls the states of the EtherCAT bus. States of the EtherCAT bus can be seen from the table below.

Table 2. States of the EtherCAT bus

State	Meaning
Bootstrap (BOOT)	Communication through Mailbox only*
Initialization (INIT)	No-Application layer communication
Pre-Operational (PREOP)	Communication through Mailbox protocols is possible
Safe-Operational (SAFEOP)	Process data (only inputs are valid)
Operational (OP)	Process data (Inputs and outputs are valid)

* Unsupported

OPTEC option board is EtherCAT-slave device and requires EtherCAT-Master device presence in the bus to operate.

The Vacon EtherCAT Option Board uses CAN application protocol over EtherCAT (CoE).

Device Profile Drives and Motion Control (CiA DSP-402) document represents the standardized CANopen Device Profile for digitally controlled motion products like servo controllers, frequency converters or stepper motors. All the above-mentioned devices use communication techniques which conform to those described in the CANopen Application Layer and Communication Profile. The starting and stopping of the drive and several mode specific commands are executed by the statemachine. The operation mode defines the behaviour of the drive. The following modes are defined in this profile:

- Homing Mode
- Profile Position Mode
- Interpolated Position Mode
- Profile Velocity Mode
- Profile Torque Mode
- Velocity Mode

The Vacon EtherCAT Option Board supports the Velocity Mode

Table 3. List of abbreviations used in this document

Abbreviation	Explanation
FB	Fieldbus
PPO	Parameter Process Data Object
PLC	Programmable Logic Controller
PHY(X)	EtherCAT physical interface X, where X represents the number of interface

Table 3. List of abbreviations used in this document

Abbreviation	Explanation
PDO	Process Data Object (Inputs and outputs. Values of type rotational speed, voltage, frequency, electric current, etc.)
RPM	Revolutions per minute
SDO	Service Data Object (Configuration settings, possibly node ID, baud rate, offset, gain, etc.)

Table 4. List of data types used in this document

Type name	Bit size	Explanation
INT8	8	Signed short integer
UINT8	8	Unsigned short integer
INT16	16	Signed integer
UINT16	16	Unsigned integer
INT32	32	Signed long integer
UINT32	32	Unsigned long integer
FLOAT32	32	32-bit floating point
STRING3	24	Three byte string
STRING5	40	Five byte string

3. ETHERCAT OPTION BOARD TECHNICAL DATA

3.1 GENERAL

Table 5. Technical data

Environment	The specifications of the drive are applicable.	
Safety	Fulfils EN50178 standard.	
Communication	bitrate	10/100 Mb/s
	Supported Mailbox protocols	CoE
Connections	Limitations	Standard Ethernet limitations, 100 m maximum cable length

3.2 CABLES

For connecting the EtherCAT devices use only Ethernet cables that meet at least the requirements of category 5 (CAT5) according to EN 50173 or ISO/IEC 11801. EtherCAT uses 4 wires for signal transfer. Vacon recommends that shielded CAT5 cables are used.

4. LAYOUT AND CONNECTIONS

The Vacon EtherCAT Option Board is connected to EtherCAT bus using the RJ-45 connectors compatible with Ethernet standard (ISO/IEC 8802-3). The communication between the control board and the frequency converter takes place through a standard Vacon Interface Board Connector.

Table 6. EtherCAT connector pin assignment

Pin	Core colouring	Signal	Description
1	yellow	TD +	Transmission Data +
2	orange	TD -	Transmission Data -
3	white	RD +	Receiver Data +
6	blue	RD -	Receiver Data -

4.1 LAYOUT AND CONNECTIONS

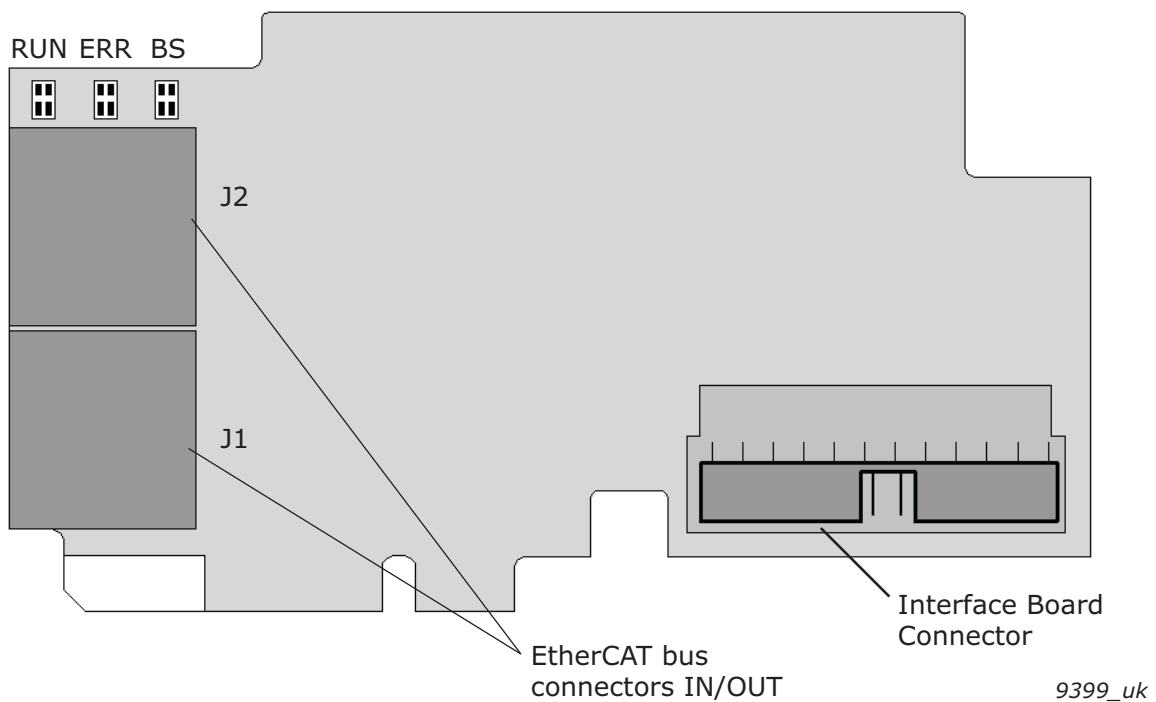

Figure 1. Vacon EtherCAT option board OPTEC

Table 7. EtherCAT connectors

EtherCAT connector	Description
J1	EtherCAT bus IN (PHY1)
J2	EtherCAT bus OUT (PHY2)

4.2 LED INDICATIONS

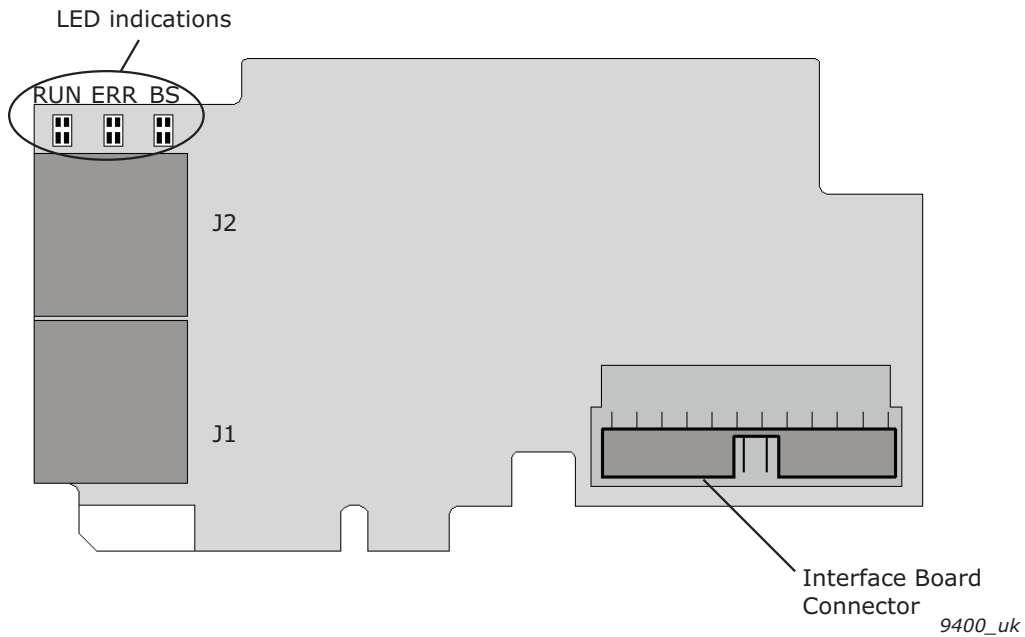

Figure 2. Vacon EtherCAT option board OPTEC LED indicators

The RUN LED indicator describes the state of the bus and the ERR LED indicator describes the status of the board.

Table 8. EtherCAT RUN, GREEN

LED RUN	Meaning
OFF	EtherCAT bus is in INITIALISATION state.
Blinking (once/0,2 s)	EtherCAT bus is in PRE-OPERATIONAL state.
Single Flash (once/2 s)	EtherCAT bus is in SAFE-OPERATIONAL state.
Flickering	EtherCAT bus is in INITIALISATION state.
ON	EtherCAT bus is in OPERATIONAL state.

Table 9. EtherCAT ERR, RED

LED ERR	Meaning
OFF	No Error
Blinking (once/0,4 s)	Invalid configuration
Single Flash (once/2 s)	ASIC synchronization error
Double Flash	Process Data Watchdog Timeout/EtherCAT Watchdog Timeout
Flickering	ASIC hardware failure
ON	Application Controller Failure

LED ERR Green is used by EtherCAT option board only at startup to indicate boot status.

Table 10. EtherCAT ERR, GREEN

LED ERR	Meaning
OFF	No Error
Blink once	Option board is powered on
Blinking	Option board boot failure

LED BS provides information about the EtherCAT option board internal state.

Table 11. BS = OPTEC board status, GREEN

LED BS	Meaning
OFF	Option board is not activated.
ON	Option board is in initialization state, waiting activation command from the frequency converter.
Blinking fast (once /1 s)	Option board is activated and in RUN state <ul style="list-style-type: none"> Option board is ready for external communication

In the case of unrecoverable error the OPTEC board will notify you of this by using the red error LED. The cause of the error will be coded into a series of long and short flashes. The sequence coded error message will repeat indefinitely. If more than one error has occurred the board will cycle through each error code repeatedly.

Table 12. Error codes

Error number	Error name	Long flashes	Short flashes	Description
1	Initialization Error	1	2	Board Initialization Failed
2	Setup Error	1	3	Board Setup Failed
3	System Error 1	1	4	Internal System Error 1
4	System Error 2	2	1	Internal System Error 2
5	System Error 3	2	2	Internal System Error 3
6	EEPROM Error	2	3	Option Board EEPROM Read/Write Error
7	ASIC Error	2	4	EtherCAT ASIC Communication Error
8	Fieldbus Error	3	1	Fieldbus Interface Error
9	OB Service Error	3	2	Option Board Service Error
10	OB Manager Error	3	3	Option Board Manager Error

4.3 TOPOLOGIES

EtherCAT supports the following Ethernet topologies:

- Line
- Daisy chain
- Daisy chain branches
- Tree
- Star
- Cable redundancy

Each of these topologies has its own advantages. Note that the start address may vary depending on which Master implementation is used. The OPTEC boards are connected using line topology.

4.4 CONNECTING THE BOARD IN LINE TOPOLOGY

Connect the EtherCAT master to IN connector of the OPTEC Option Board using an Ethernet cable. For more information, see the figure below.

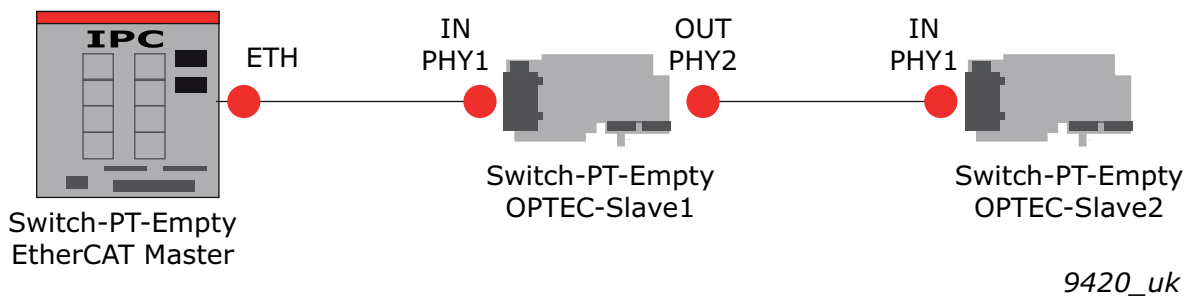

Figure 3. Vacon OPTEC option board EtherCAT IN/OUT

After the EtherCAT master is connected to the OPTEC Option Board and the power is switched on in both devices, the Rx-Led of the IN connector in the OPTEC Option Board should be on or blinking depending on if there is communication in the bus or not. The Tx-Led is not used.

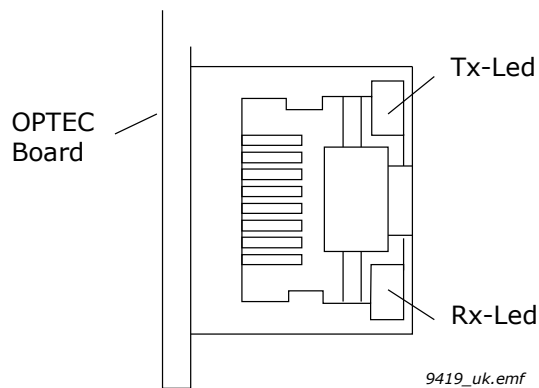

Figure 4. OPTEC option board EtherCAT in connector

5. INSTALLATION

5.1 INSTALLATION IN VACON® NXP



Make sure that the AC drive **is switched off** before an option or fieldbus board is changed or added!

1	<p>Vacon NX AC drive.</p>  <p style="text-align: right; font-size: small;">7062.jpg</p>
---	--

2	<p>Remove the cable cover.</p> 
---	---

3

Open the cover of the control unit.

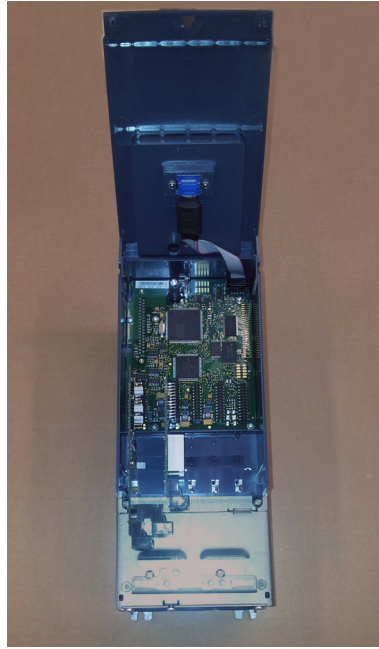

4

Install the OPTEC EtherCAT Option Board in slot D or E on the control board of the AC drive. Make sure that the grounding plate (see below) fits tightly in the clamp.

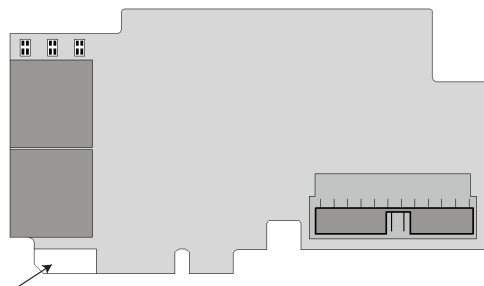

5

Make a sufficiently wide opening for your cable by cutting the grid as wide as necessary.

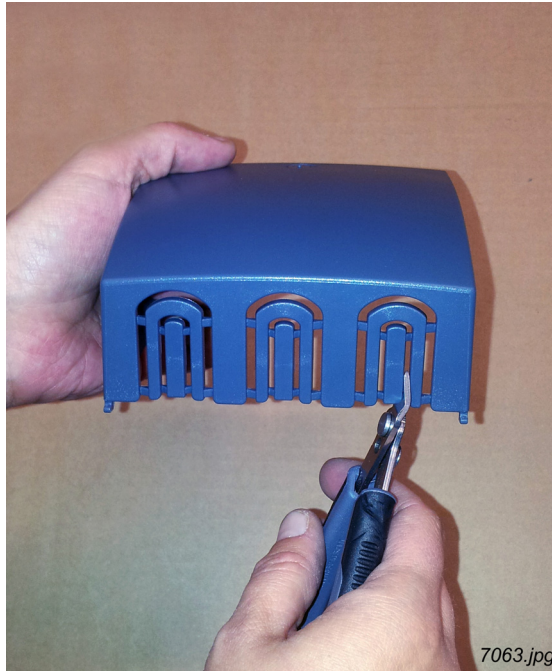

6

Close the cover of the control unit and the cable cover.



5.2 INSTALLATION IN VACON® 20

5.2.1 FRAMES MI1, MI2, MI3



Make sure power is disconnected before installing the option board mounting kit.

1

Detach the cable connector protective lid from V20.

11555_00

2

Attach a suitable grounding plate to option board mounting frame. The grounding plate is marked with supported frame size.

Attach an option board mounting frame to V20.

11556_00

3

Connect the flat cable from the option board mounting frame to V20.

11557_00

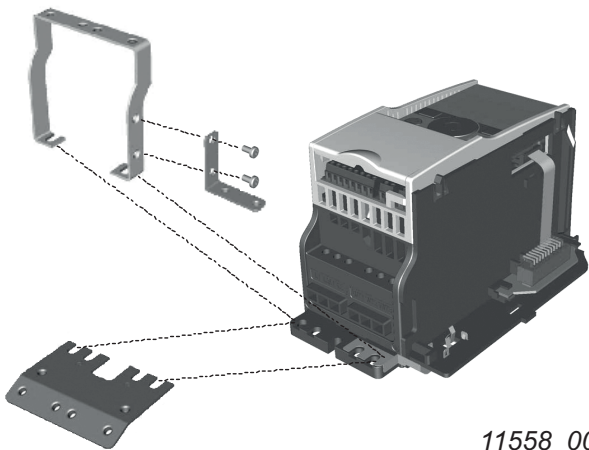
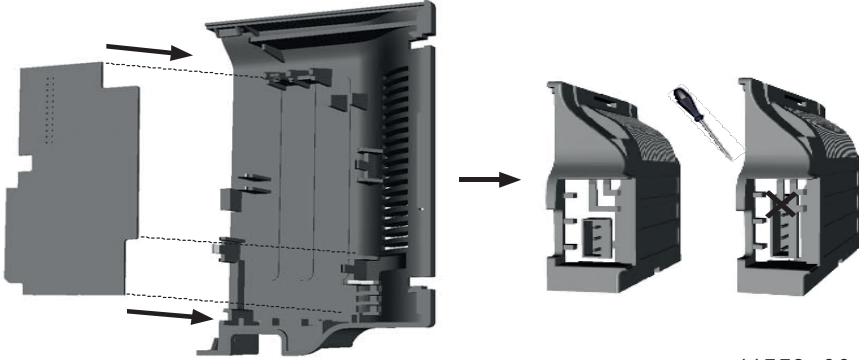
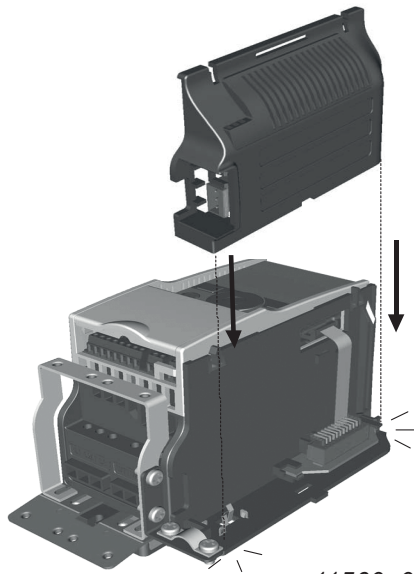
<p style="text-align: center; font-size: 2em; font-weight: bold;">4</p>	<p>If a cable strain relief is required, attach the parts as shown.</p>  <p style="text-align: right;">11558_00</p>
<p style="text-align: center; font-size: 2em; font-weight: bold;">5</p>	<p>Attach the option board to option board holder. Make sure the option board is securely fastened. Cut free a sufficiently wide opening for the option board connector.</p>  <p style="text-align: right;">11559_00</p>
<p style="text-align: center; font-size: 2em; font-weight: bold;">6</p>	<p>Attach the option board cover to V20. Attach the strain relief cable clamp with screws if needed.</p>  <p style="text-align: right;">11560_00</p>

5.2.2 FRAMES MI4, MI5



Make sure power is disconnected before opening the V20 cover.

1	<p>1a: For MI4: Open the cover.</p> <p style="text-align: right;">11561_00</p> <p>1b: For MI5: Open the cover and release the fan connector.</p> <p style="text-align: right;">11562_00</p>
2	<p>Attach the option board support.</p> <p style="text-align: right;">11563_00</p>

3 Connect the flex cable to option board connector PCB.

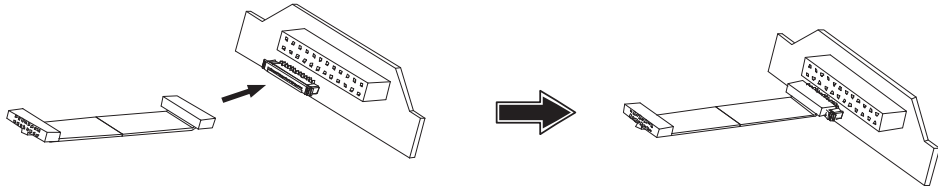

11564_00

4 Connect the option board to connector PCB.

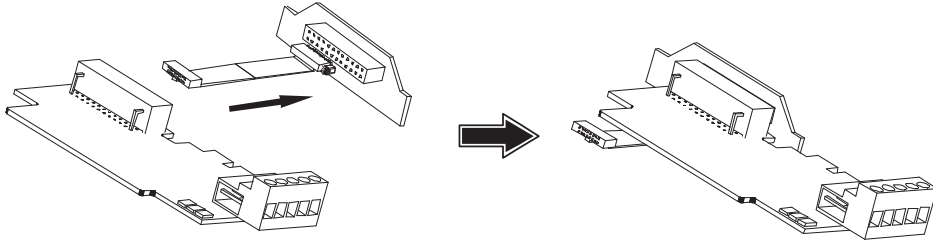

11565_00

5 Attach the option board with connector PCB to V20 and connect the flex cable.

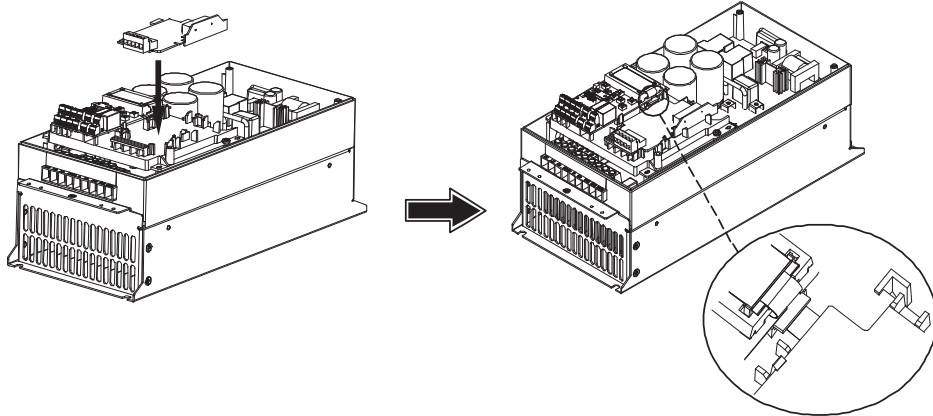

11566_00

6 Attach a suitable grounding plate to V20. The grounding plate is marked with supported frame size.

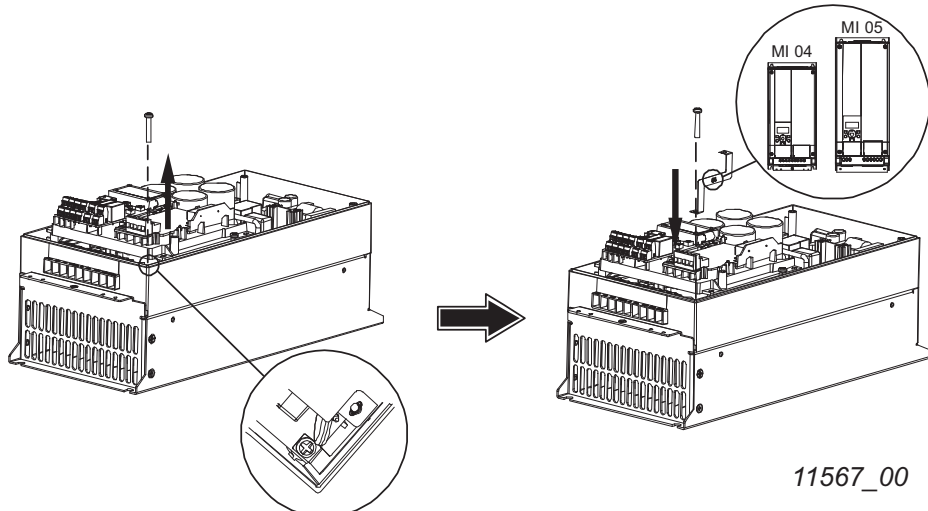

11567_00

7

Assemble a clamp on top of the grounding plate on both sides of the option board.

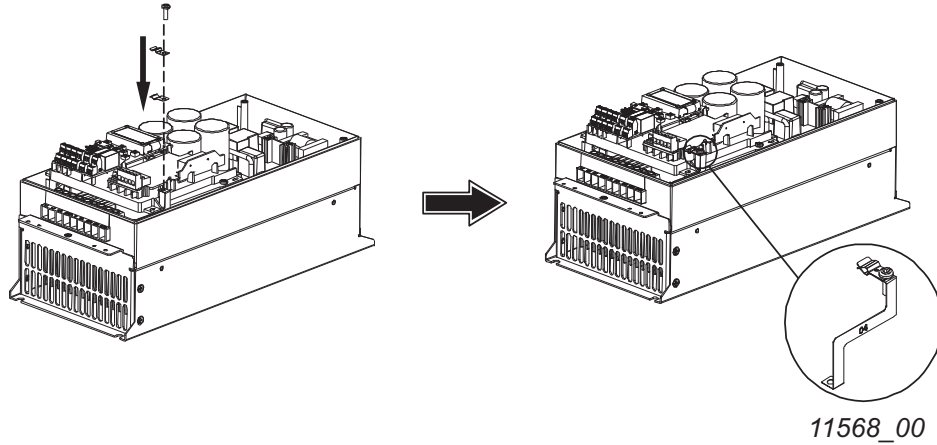

8

8a: For MI4: Close the cover.

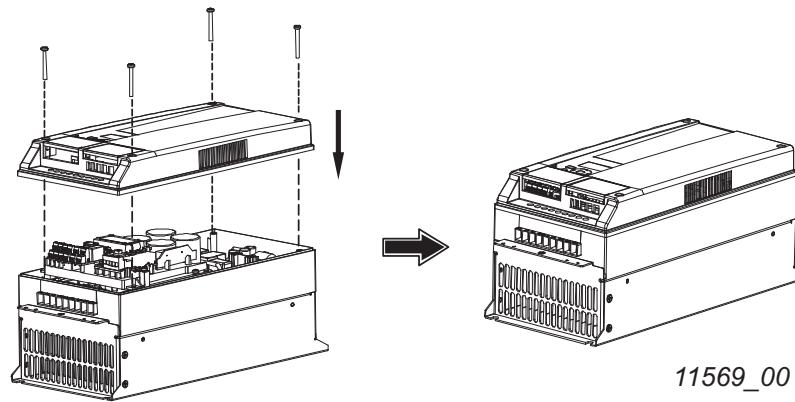

8b: For MI5: Remount the fan connector and close the cover.

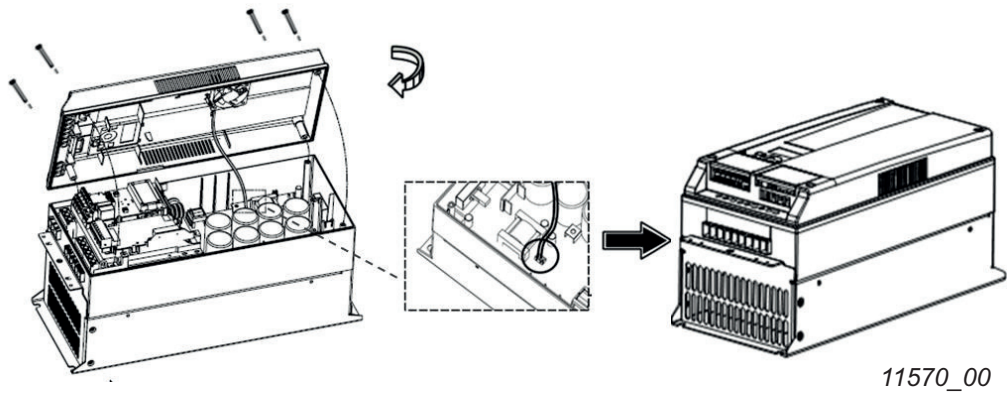

5.3 INSTALLATION IN VACON® 100

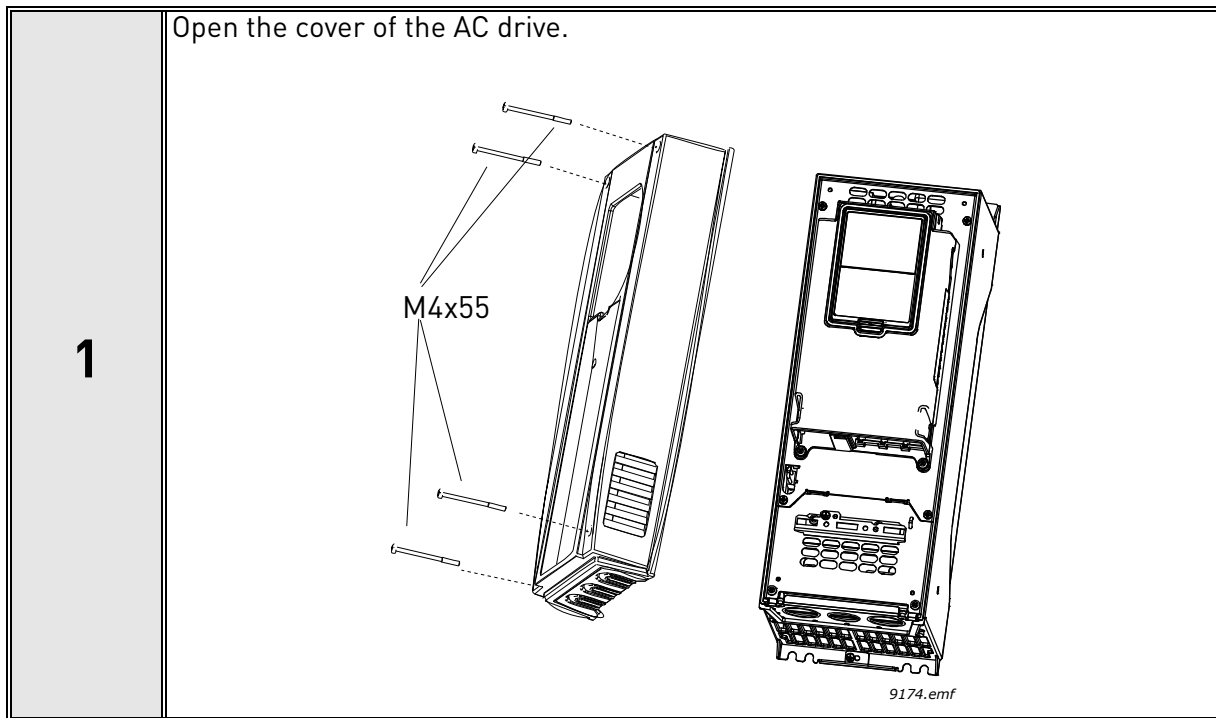

The relay outputs and other I/O-terminals may have a dangerous control voltage present even when Vacon 100 is disconnected from mains.

2

Open the inner cover to reveal the option board slots (C,D,E). See Figure below.

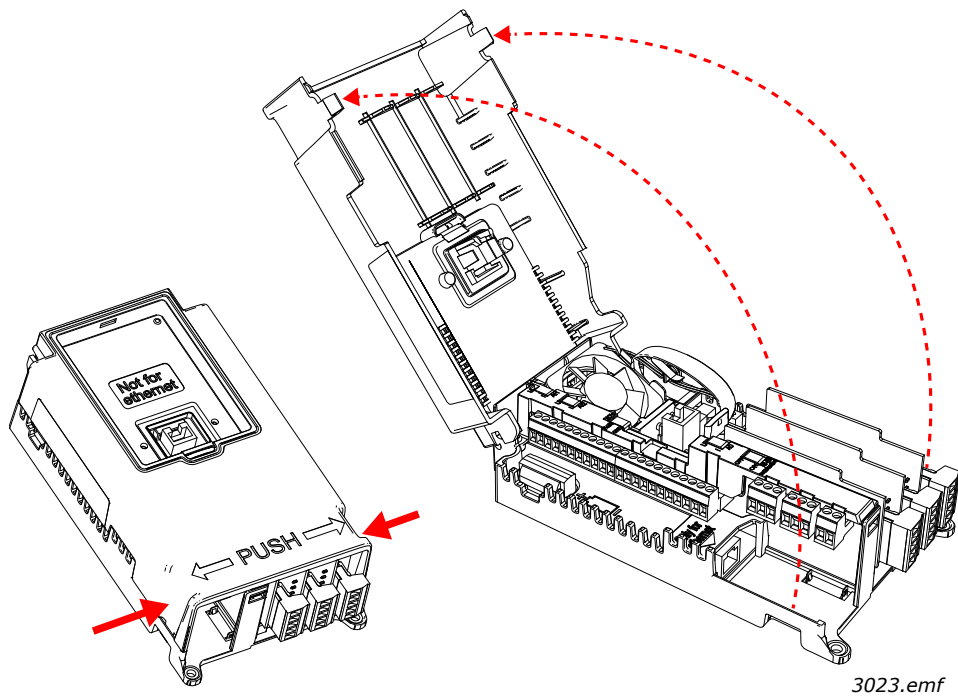

3

Install the fieldbus board into slot D or E. See figure below.
NOTE: Incompatible boards cannot be installed on Vacon 100. Compatible boards have a slot coding that enable the placing of the board.

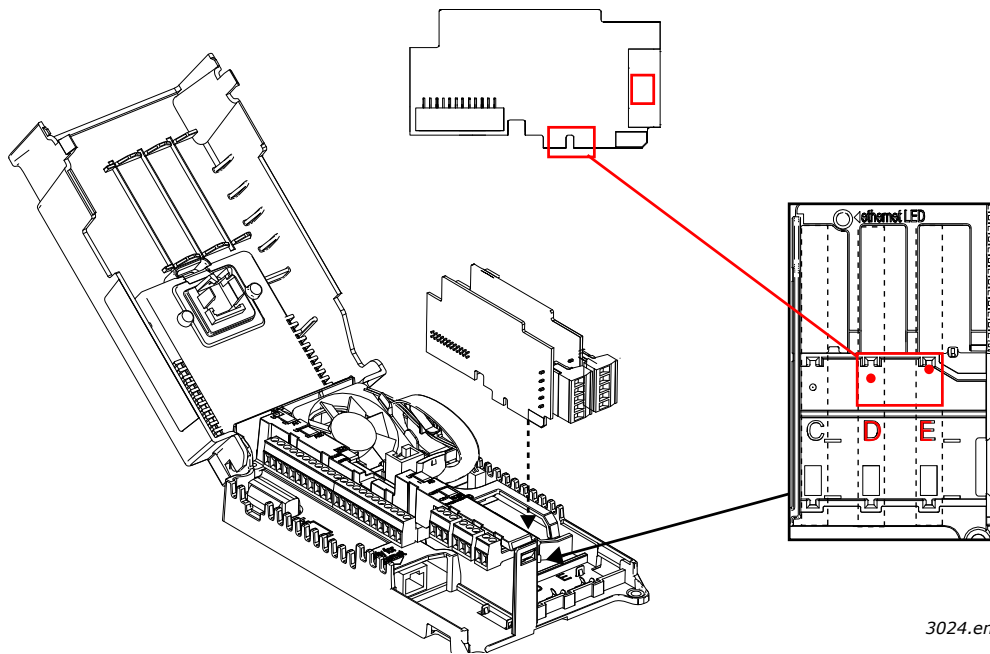

4

Then connect the cable to its appropriate OPTEC EtherCAT option board RJ-45 connector.

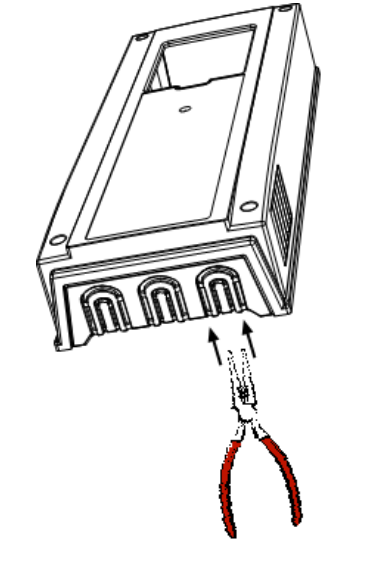
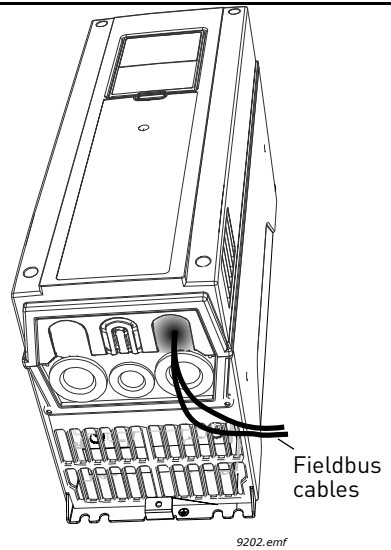
<p style="text-align: center; font-size: 24pt; font-weight: bold;">5</p>	<p>Unless already done for the other control cables, cut free the opening on the AC drive cover for the fieldbus cable (protection class IP21).</p> <p>NOTE: Cut the opening on the same side you have installed the board in!</p>	
<p style="text-align: center; font-size: 24pt; font-weight: bold;">6</p>	<p>Remount the AC drive cover and run the cable as shown in picture.</p> <p>NOTE: When planning the cable runs, remember to keep the distance between the fieldbus cable and the motor cable at a minimum of 30 cm. It is recommended to route the option board cables away from the power cables as shown in the picture.</p>	

6. COMMISSIONING

6.1 SUPPORTED DRIVES

The following table shows which drives support the OPTEC board.

Table 13. List of supported drives and slots

Drive	Slot(s)	Drive SW version	OPTEC SW version
NXP	D, E	>=NXP00002V187	>=1.0
Vacon 20		>=FW0107V009	>=1.0
Vacon 20X/CP		>=FW0117V006	>=2.0
Vacon 100 / 100X	D, E	>=FW0072V016	>=2.0
Vacon 100 FLOW	D, E	>=FW0159V010	>=2.0

6.2 OPTEC BOARD PARAMETERS

Parameters can be accessed through the panel of the drive or by computer using the parameterization tool.

Table 14. OPTEC board parameters

CODE			Parameter	Description
V20	V100	NXP		
-	5.x.4.1	6.8.6.x.2	Version number	Version number of the board software
-	5.x.4.2	6.8.6.x.1	Board Status	State of the OPTEC board application

6.3 UPDATING THE FIRMWARE OF OPTEC OPTION BOARD WITH VACON LOADER

You can download Vacon Loader from the website www.vacon.com. Vacon Loader is bundled with the Vacon Live software package. To update the firmware of the option board, follow the steps below:

1

Connect your PC to the controller by using the USB/RS485 cable.
 Select the firmware file, which you want to install on the option board, and double click it. The Vacon Loader software starts.
 You can also start the program from the Windows Start menu. In this case, select the firmware file by using the Browse button.

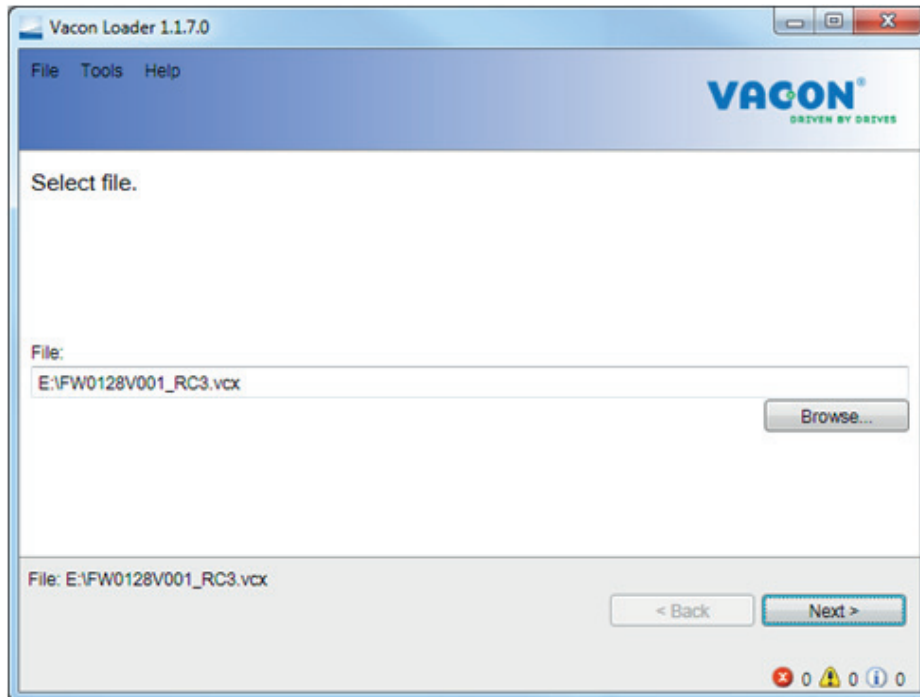

9452

2

Click the Next button and wait for the loader to find the network drives.
 Select a drive from the list and click the Connect to Selected button.

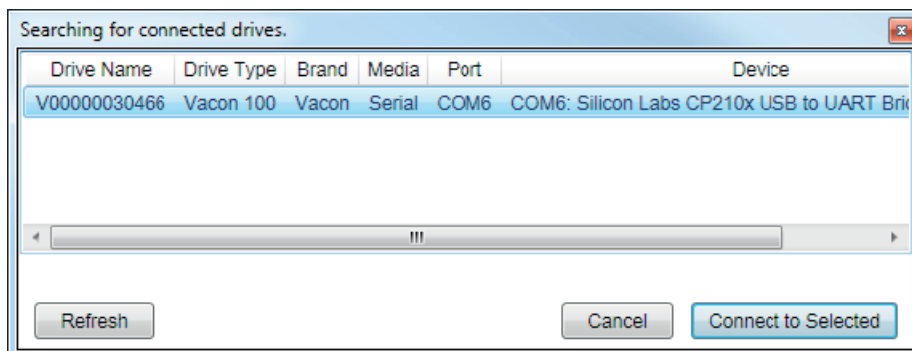

9453

3

Select the modules to be updated, click the Next button and wait until the operation finishes.

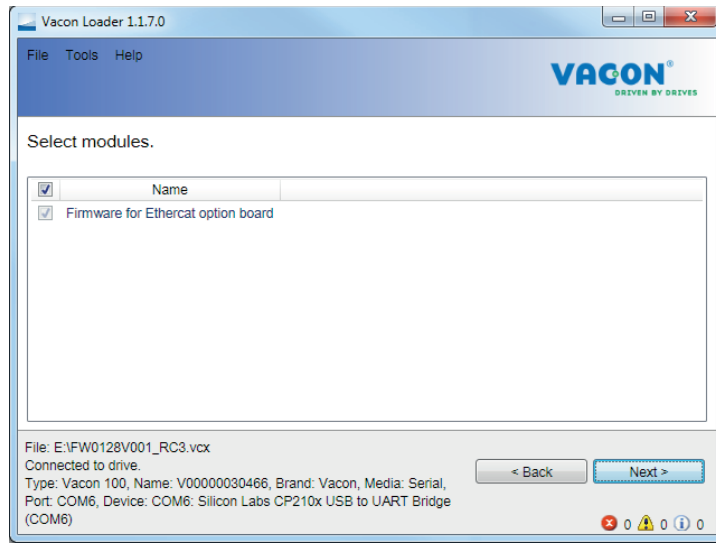

9454

4

When the firmware is loaded, close the application.

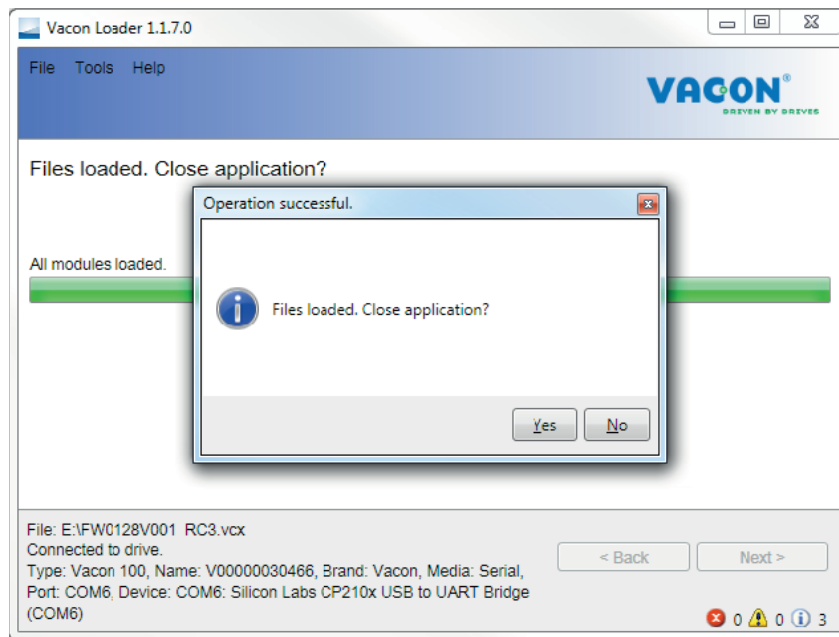

9455

6.4 ESTABLISHING A CONNECTION TO ETHERCAT BUS

The OPTEC Option Board is configured via EtherCAT bus. The connection to EtherCAT bus can be established with any kind of EtherCAT Master but, in these instructions, Beckhoff TwinCAT is used. Beckhoff TwinCAT can be downloaded from: <http://www.beckhoff.com>.

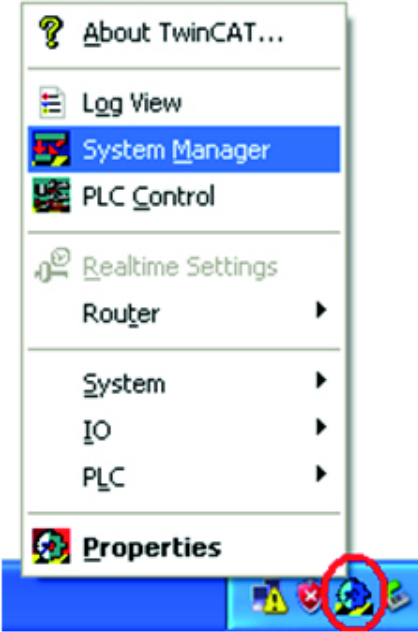
1	Connect the Ethernet cable from the Ethernet card of the computer to the IN Connector of the OPTEC Option Board EtherCAT (for more information see Chapter 4.1 "Layout and connections").
2	<p>Start the TwinCAT System Manager by right-clicking on the toolbar icon and by selecting 'System Manager'.</p>  <p style="text-align: right; font-size: small;">11258.jpg</p>

3

In the TwinCAT System Manager, go to 'Options' -> 'Show Real Time Ethernet Compatible Devices...'

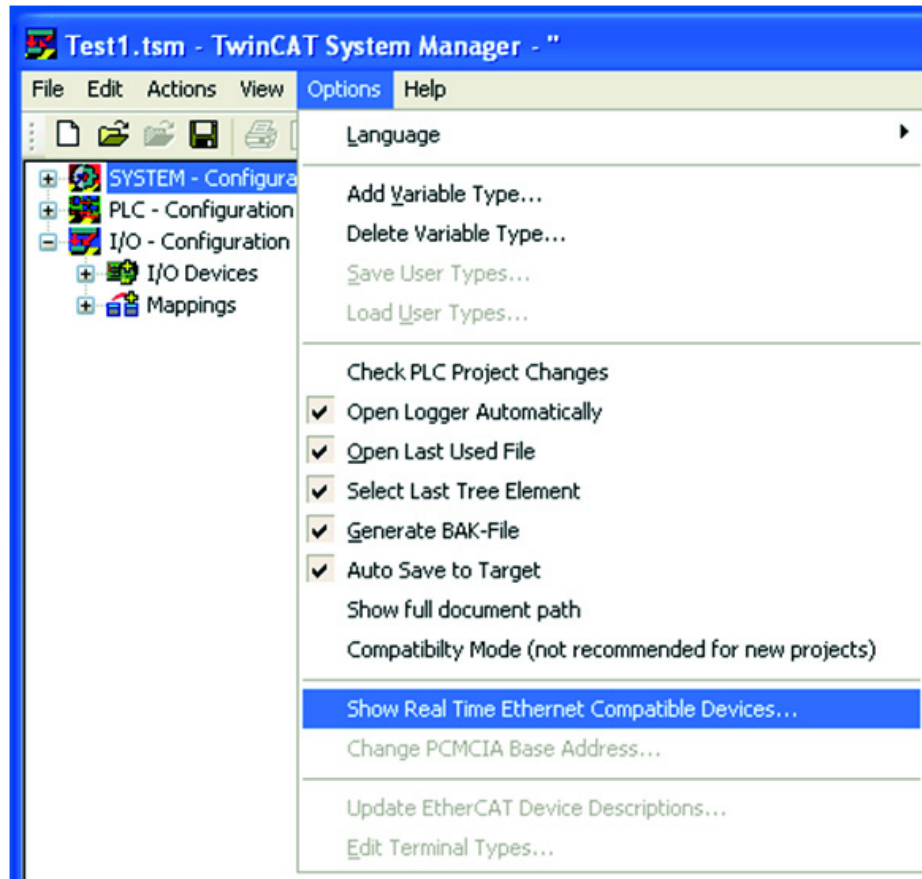

11259.jpg

4

In the first phase your Ethernet card is shown under "Incompatible devices". Select the card and click "Install". After this operation the card is visible under "Installed and ready to use devices".

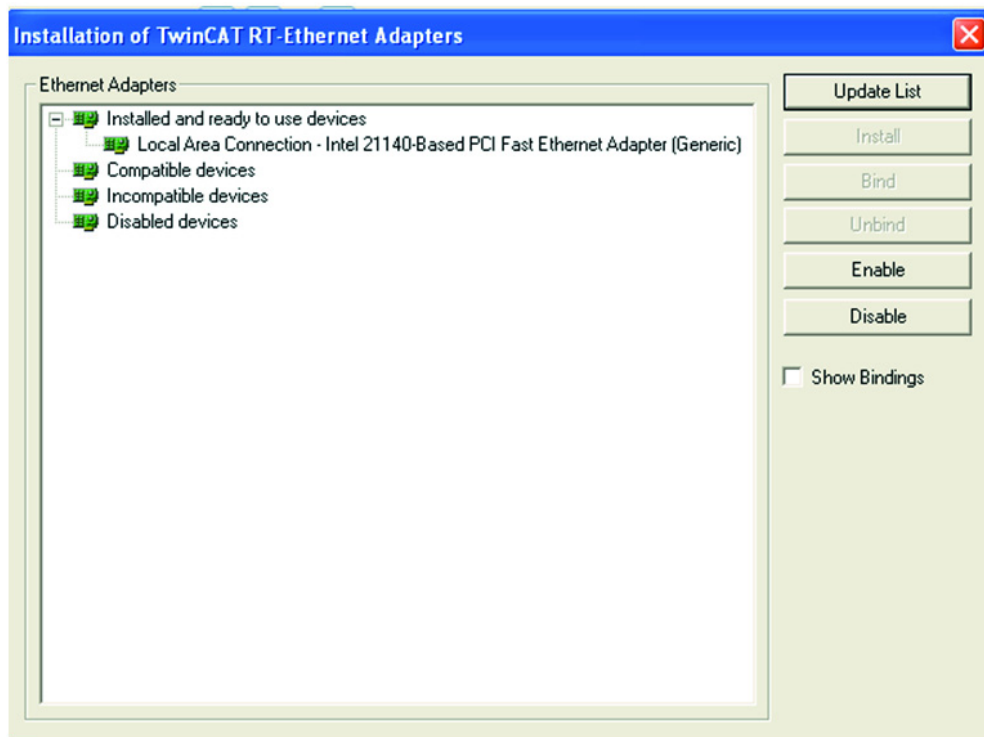

11260.jpg

5 Make sure that TwinCAT is in the Config mode (check that the text Config mode is visible in the bottom right corner).

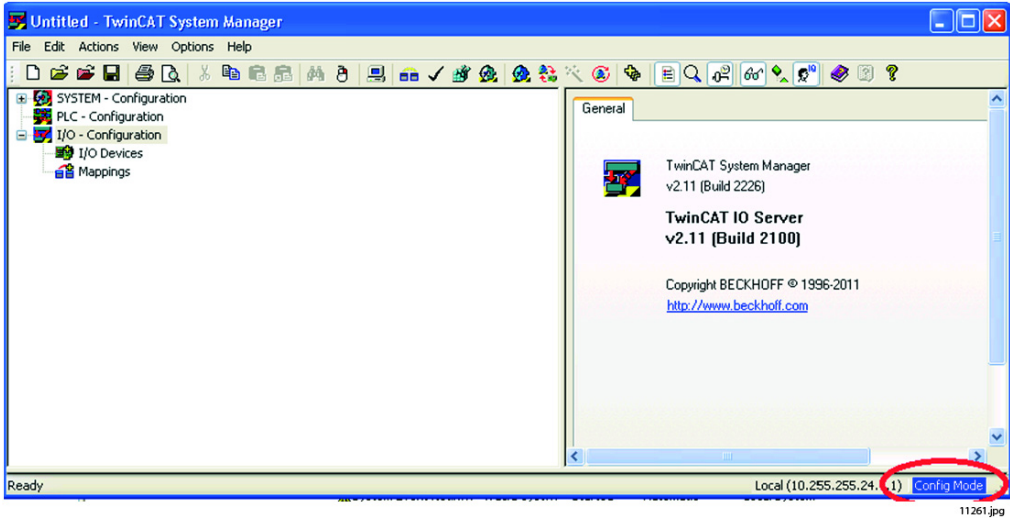

The screenshot shows the 'Untitled - TwinCAT System Manager' window. The 'General' tab is active, displaying version information for TwinCAT System Manager v2.11 (Build 2226) and TwinCAT IO Server v2.11 (Build 2100). In the bottom right corner of the window, the text 'Config Mode' is highlighted with a red circle.

6 If this is not the case, switch the TwinCAT System Manager to the Config Mode by clicking 'Set/Reset TwinCAT to Config Mode'.



The screenshot shows a close-up of the toolbar. The icon for 'Set/Reset TwinCAT to Config Mode' is circled in red.

7 In the 'Load I/O devices?' dialog, click 'Yes'.

8 In the 'Active Free Run?' dialog, click 'No'

9 Start a new project by clicking 'New' from the toolbar or by clicking 'File' -> 'New'.

10 Scan the devices by right-clicking on top of the 'I/O devices' tree item and by selecting 'Scan Devices...'.

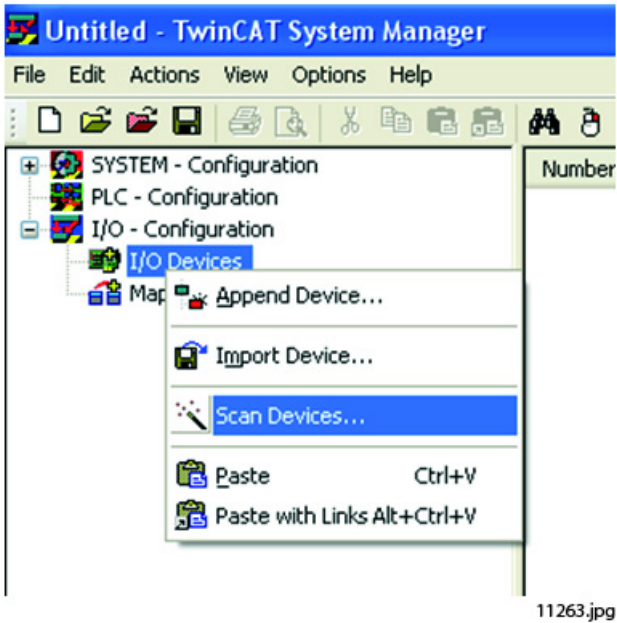

The screenshot shows the 'I/O Devices' tree item selected in the left pane. A context menu is open over it, with the 'Scan Devices...' option highlighted. Other options include 'Append Device...', 'Import Device...', 'Paste', and 'Paste with Links'.

11

Select the Ethernet card used for communication with the OPTEC Option Board (the Ethernet card which is connected to the IN connector of the OPTEC Option Board), and click 'OK'.

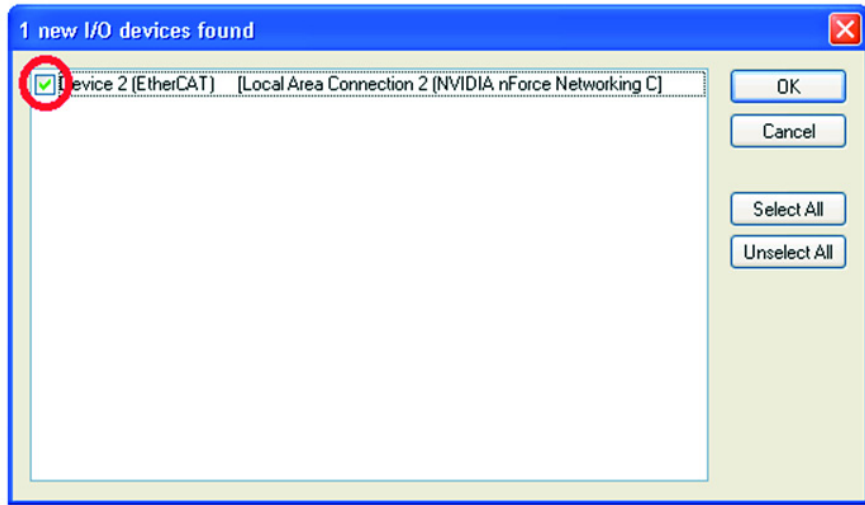

11264.jpg

12

In the 'Scan for boxes?' dialog, click 'Yes'.

13

To switch the EtherCAT bus to OPERATIONAL state, click 'Yes' in the 'Activate free run?' dialog.

14

When the connection has been established, TwinCAT looks like in the picture below.

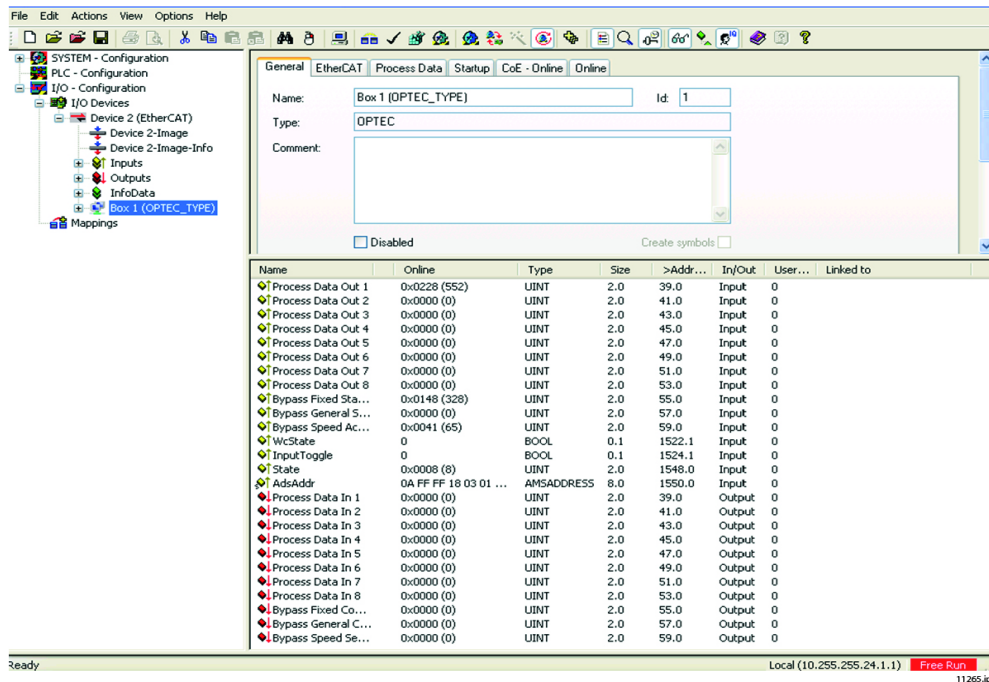

6.5 WRITING AND READING PROCESS DATA

This chapter explains briefly how you can read and write data objects from and to the OPTEC Option Board using TwinCAT System Manager.

6.5.1 WRITING DATA OBJECT VALUE TO OPTEC OPTION BOARD

1 Establish the connection to EtherCAT bus as instructed in Chapter 6.4 "Establishing a connection to EtherCAT bus".

2 In the tree on the left side, select the desired OPTEC Option Board under the bus. In the list on the right side, select the desired data object, right-click and, in the context menu that opens, select 'Online Write...':

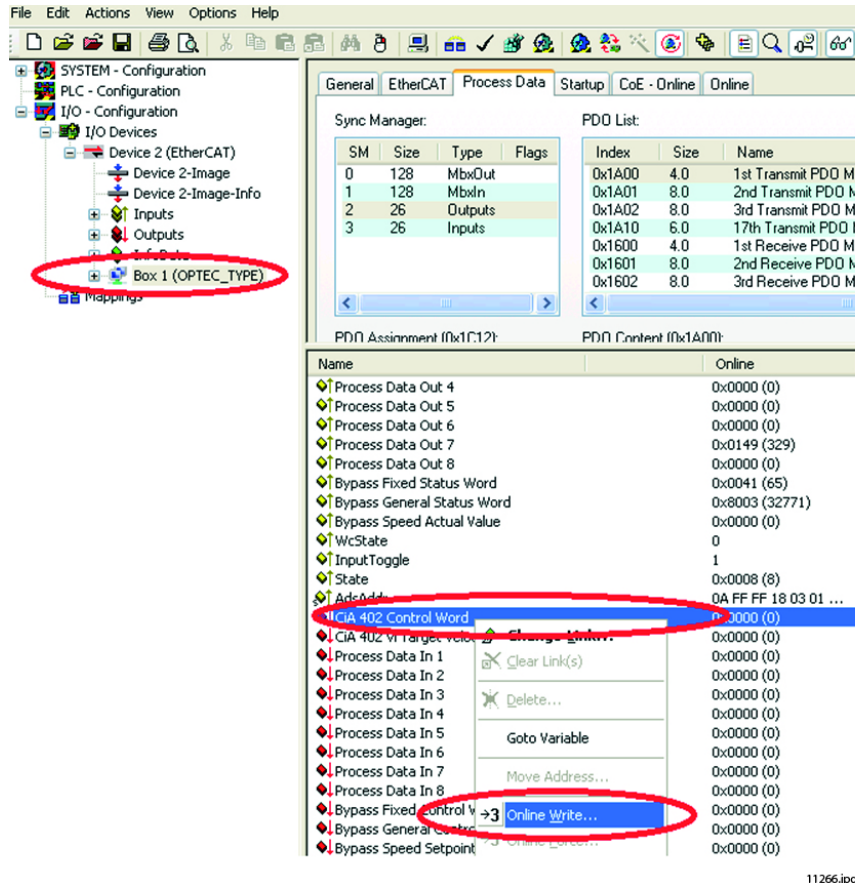

3 In the 'Set Value Dialog', enter the value in desired form and click 'OK'.

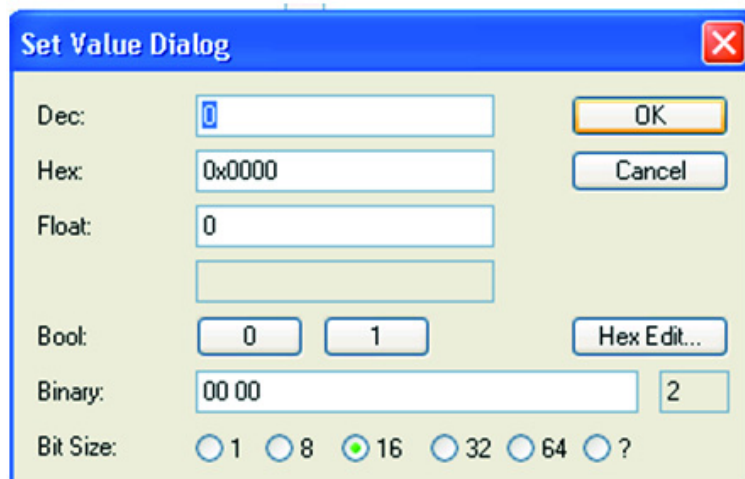

6.5.2 READING DATA OBJECT VALUES FROM OPTEC OPTION BOARD

1 Establish the connection to EtherCAT bus as instructed in Chapter 6.4 "Establishing a connection to EtherCAT bus".

2 In the tree on the left side, select the desired OPTEC Option Board under the EtherCAT device. The values of the EtherCAT Process Data objects can be seen in bottom list. To see the values of the CoE Data objects, click the 'CoE - Online' tab. To see the CoE Data objects in real time, select 'Auto Update'.

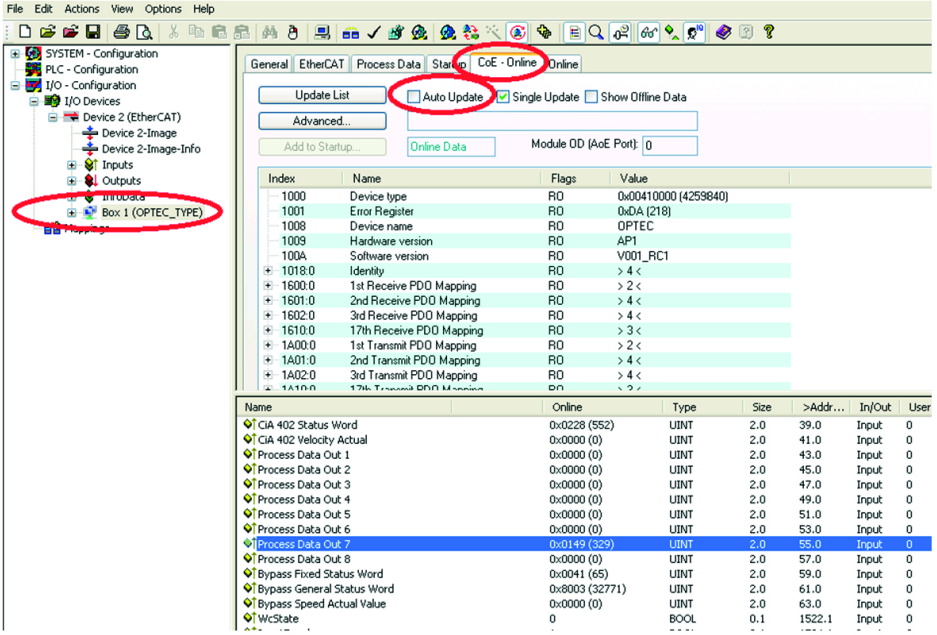

Index	Name	Flags	Value
1000	Device type	RO	0x00410000 (4259840)
1001	Error Register	RO	0xdA (218)
1008	Device name	RO	OPTEC
1009	Hardware version	RO	AP1
100A	Software version	RO	V001_RC1
1018.0	Identity	RO	> 4 <
1600.0	1st Receive PDO Mapping	RO	> 2 <
1601.0	2nd Receive PDO Mapping	RO	> 4 <
1602.0	3rd Receive PDO Mapping	RO	> 4 <
1610.0	17th Receive PDO Mapping	RO	> 3 <
1A00.0	1st Transm PDO Mapping	RO	> 2 <
1A01.0	2nd Transm PDO Mapping	RO	> 4 <
1A02.0	3rd Transm PDO Mapping	RO	> 4 <
1A10.0	17th Transm PDO Mapping	RO	> 2 <

Name	Online	Type	Size	>Addr...	In/Out	User
↓ CIA 402 Status Word	0x0228 (552)	UINT	2.0	39.0	Input	0
↓ CIA 402 Velocity Actual	0x0000 (0)	UINT	2.0	41.0	Input	0
↓ Process Data Out 1	0x0000 (0)	UINT	2.0	43.0	Input	0
↓ Process Data Out 2	0x0000 (0)	UINT	2.0	45.0	Input	0
↓ Process Data Out 3	0x0000 (0)	UINT	2.0	47.0	Input	0
↓ Process Data Out 4	0x0000 (0)	UINT	2.0	49.0	Input	0
↓ Process Data Out 5	0x0000 (0)	UINT	2.0	51.0	Input	0
↓ Process Data Out 6	0x0000 (0)	UINT	2.0	53.0	Input	0
↓ Process Data Out 7	0x0149 (329)	UINT	2.0	55.0	Input	0
↓ Process Data Out 8	0x0000 (0)	UINT	2.0	57.0	Input	0
↓ Bypass Fixed Status Word	0x0041 (65)	UINT	2.0	59.0	Input	0
↓ Bypass General Status Word	0x8003 (32771)	UINT	2.0	61.0	Input	0
↓ Bypass Speed Actual Value	0x0000 (0)	UINT	2.0	63.0	Input	0
↓ WcState	0	BOOL	0.1	1522.1	Input	0

6.6 SWITCHING OPERATING MODES

The OPTEC Option Board has two operating modes: Bypass and CiA-402. Switching between these two modes is explained in the two chapters below. More information about Bypass mode and CiA-402 mode can be found from Chapter 7.3 "OPTEC modes".

6.6.1 SWITCHING TO BYPASS MODE

1 Establish the connection to EtherCAT bus as instructed in Chapter 6.4 "Establishing a connection to EtherCAT bus".

2 In the tree on the left side, select the desired OPTEC Option Board, and select 'Process data' tab.

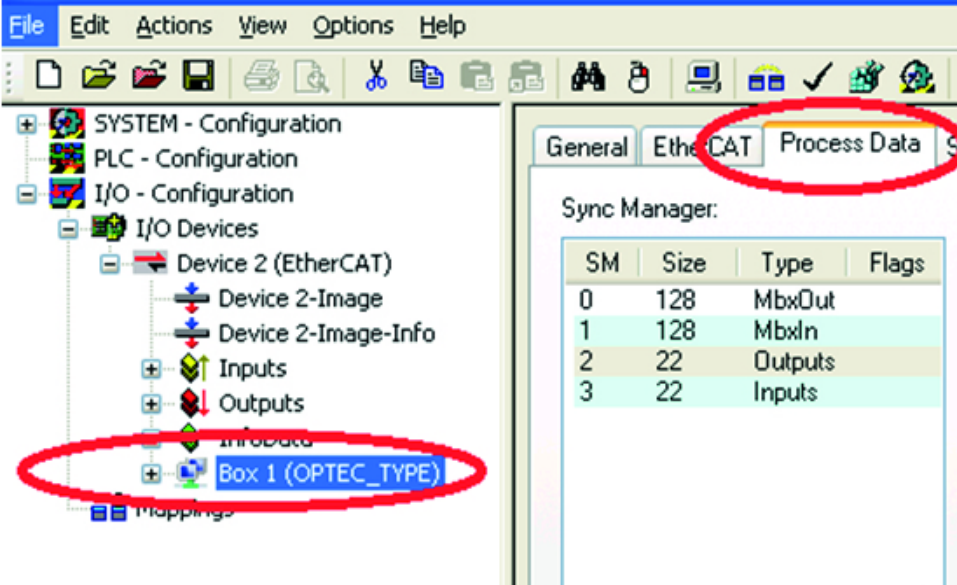

SM	Size	Type	Flags
0	128	MbxOut	
1	128	MbxIn	
2	22	Outputs	
3	22	Inputs	

11269.jpg

3 Under 'Inputs', click to clear the PDO Assignment '0x1A00' checkbox. Under 'Outputs', click to clear the PDO Assignment '0x1600' checkbox.

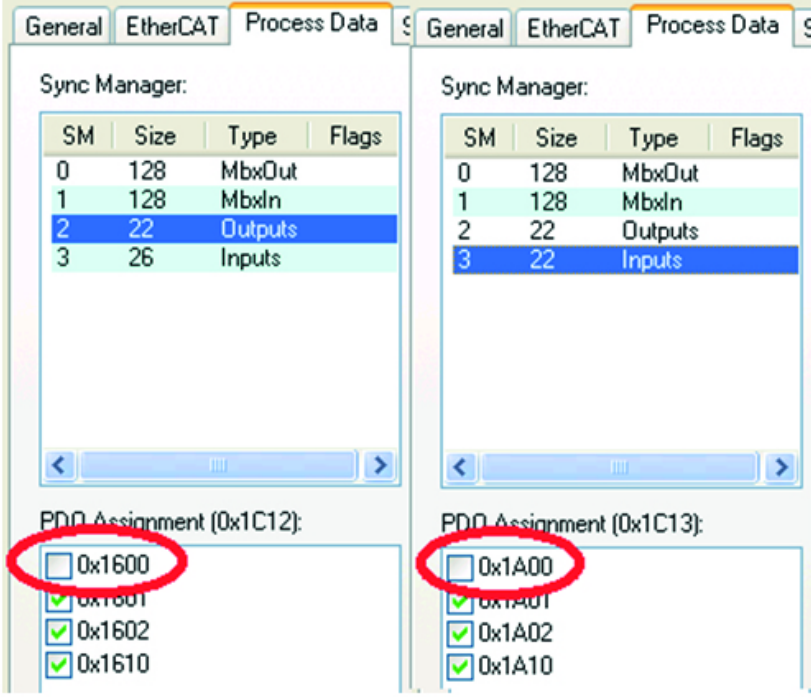

SM	Size	Type	Flags
0	128	MbxOut	
1	128	MbxIn	
2	22	Outputs	
3	26	Inputs	

SM	Size	Type	Flags
0	128	MbxOut	
1	128	MbxIn	
2	22	Outputs	
3	22	Inputs	

11270.jpg

4

Under 'Download', make sure that 'PDO Assignment' and 'PDO Configuration' are selected.

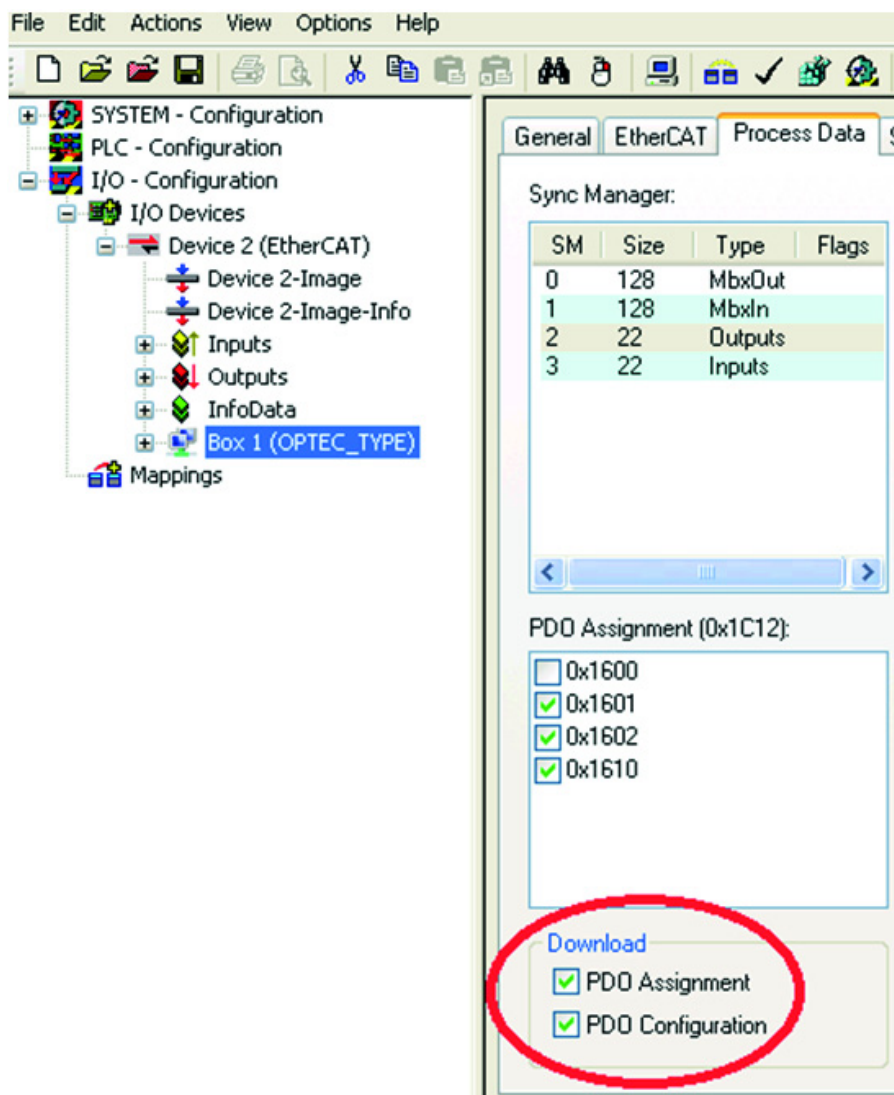

11271.jpg

5

Reset TwinCAT to configuration mode by clicking 'Set/Reset TwinCAT config mode' from the toolbar.



11272.jpg

6

In the 'Restart TwinCAT System in Config Mode' dialog, click 'OK'.

7

In the 'Load I/O Devices' dialog, click 'Yes'.

8

In the 'Activate Free Run' dialog, click 'Yes'.

9

To verify that the OPTEC Option Board is in the Bypass mode, select the 'CoE - Online' tab and make sure that there are only three subitems under both Can object groups 'RxPDO' and 'TxPDO'.

Index	Name	Flags	Value
1000	Device type	RO	0x00410000 (4259840)
1001	Error Register	RO	0xDA (218)
1008	Device name	RO	OPTEC
1009	Hardware version	RO	AP1
100A	Software version	RO	V001_RC1
+ 1018:0	Identity	RO	> 4 <
+ 1600:0	1st Receive PDO Mapping	RO	> 2 <
+ 1601:0	2nd Receive PDO Mapping	RO	> 4 <
+ 1602:0	3rd Receive PDO Mapping	RO	> 4 <
+ 1610:0	17th Receive PDO Mapping	RO	> 3 <
+ 1A00:0	1st Transmit PDO Mapping	RO	> 2 <
+ 1A01:0	2nd Transmit PDO Mapping	RO	> 4 <
+ 1A02:0	3rd Transmit PDO Mapping	RO	> 4 <
+ 1A10:0	17th Transmit PDO Mapping	RO	> 3 <
+ 1C00:0	Sync manager type	RO	
+ 1C12:0	RxPDO assign	RW	> 3 <
+ 1C13:0	TxPDO assign	RW	> 3 <
+ 1C32:0	SM output parameter	RO	

6.6.2 SWITCHING TO CIA-402 MODE

1

Establish the connection to EtherCAT bus as instructed in Chapter 6.4 "Establishing a connection to EtherCAT bus".

2

In the tree on the left side, select the desired OPTEC Option Board, and select the 'Process data' tab.

SM	Size	Type	Flags
0	128	MbxOut	
1	128	MbxIn	
2	22	Outputs	
3	22	Inputs	

3

Under 'Inputs', select the PDO Assignment '0x1A00'. Under 'Outputs', select the PDO Assignment '0x1600'.

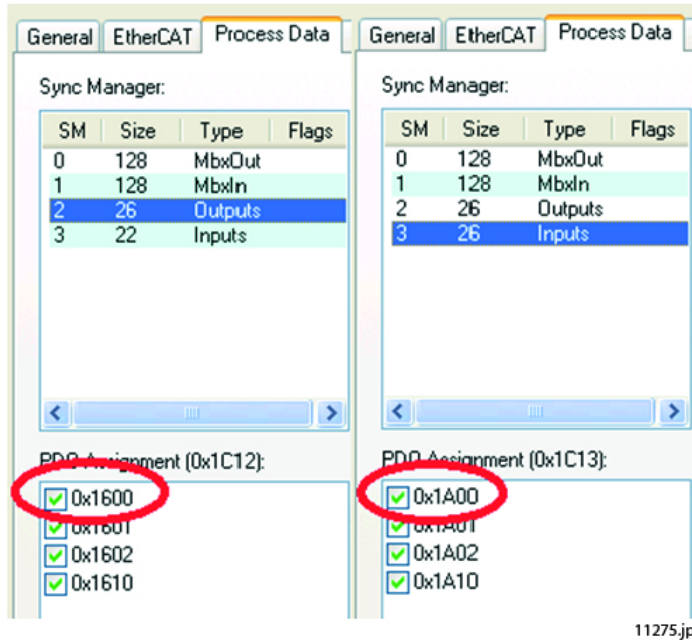

11275.jpg

4

Make sure that 'PDO Assignment' and 'PDO Configuration' are selected.

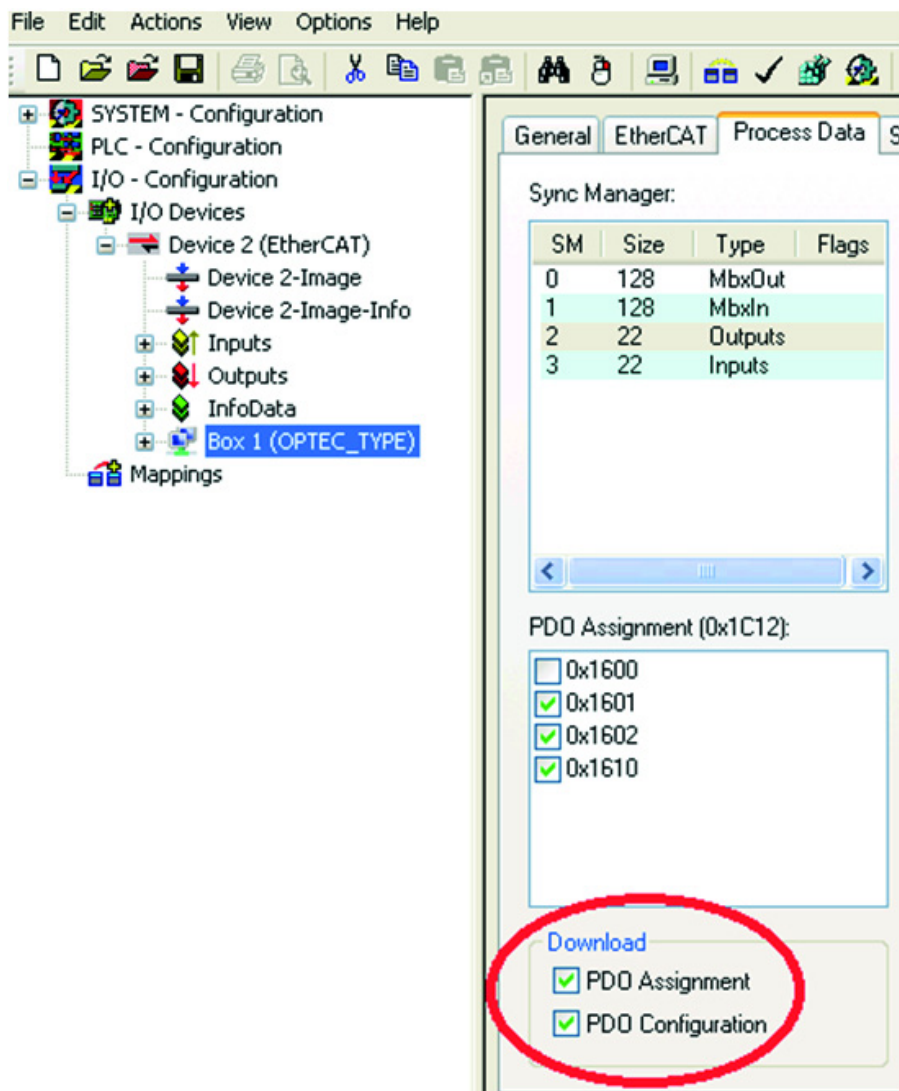

11271.jpg

5 Reset TwinCAT to configuration mode by clicking 'Set/Reset TwinCAT config mode' from the toolbar.



6 In the 'Restart TwinCAT System in Config Mode' dialog, click 'OK'.

7 In the 'Load I/O Devices' dialog, click 'Yes'.

8 In the 'Activate Free Run' dialog, click 'Yes'.

9 To verify that the OPTEC Option Board is in the Bypass mode, select the 'CoE - Online' tab and make sure that there are four subitems under both Can object groups 'RxPDO' and 'TxPDO'.

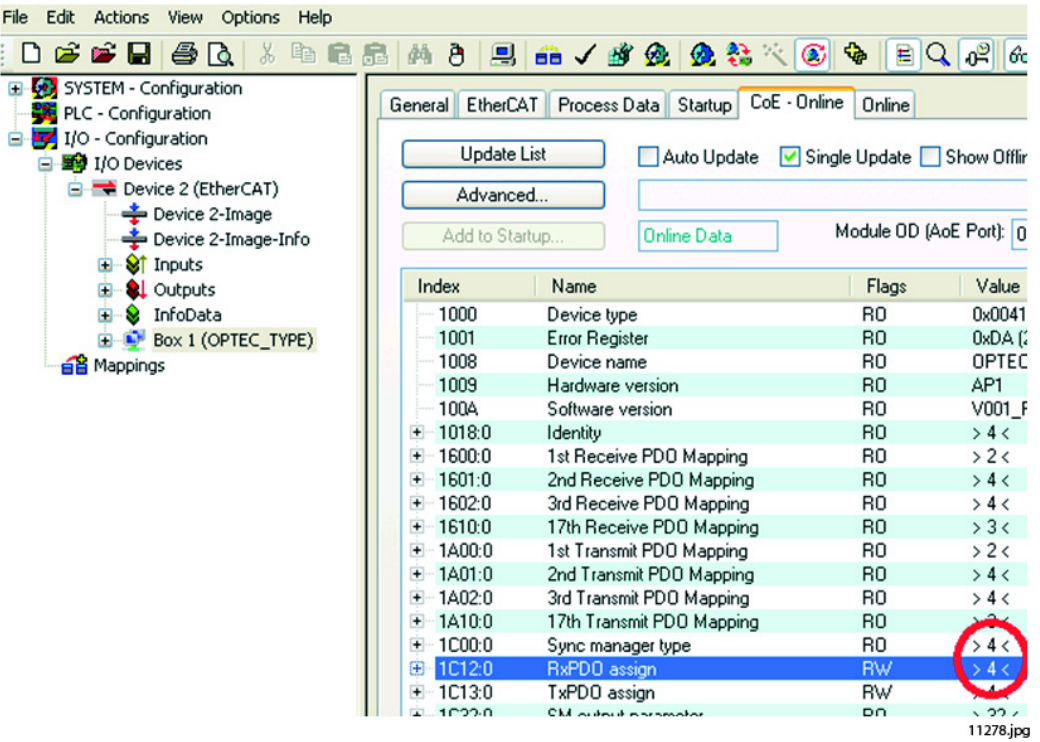

Index	Name	Flags	Value
1000	Device type	RO	0x0041
1001	Error Register	RO	0xDA (;
1008	Device name	RO	OPTEC
1009	Hardware version	RO	AP1
100A	Software version	RO	V001_F
1018:0	Identity	RO	> 4 <
1600:0	1st Receive PDO Mapping	RO	> 2 <
1601:0	2nd Receive PDO Mapping	RO	> 4 <
1602:0	3rd Receive PDO Mapping	RO	> 4 <
1610:0	17th Receive PDO Mapping	RO	> 3 <
1A00:0	1st Transmit PDO Mapping	RO	> 2 <
1A01:0	2nd Transmit PDO Mapping	RO	> 4 <
1A02:0	3rd Transmit PDO Mapping	RO	> 4 <
1A10:0	17th Transmit PDO Mapping	RO	> 3 <
1C00:0	Sync manager type	RO	> 4 <
1C12:0	RxPDO assign	RW	> 4 <
1C13:0	TxPDO assign	RW	> 4 <
1C20:0	CM subitem number	on	> 22 <

6.7 CONTROLLING THE MOTOR IN CiA-402 MODE

In order to control the drive with the OPTEC Option Board, change the value of parameter Remote Control Place to Fieldbus control and the value of parameter Control mode to Speed control open loop.

After the value of the Control Place parameter has been changed, the frequency converters motor can be controlled using the two data objects, CiA-402 Control Word and CiA-402 vl Target Velocity.

To switch the frequency converter to RUN mode, write the following commands to the CiA-402 Control Word Data Object.

Table 15. Motor startup sequence in CiA-402 mode

Command	Description	CiA-402 State
0x80	Reset Active faults from the frequency converter if there is any	Switch on disabled
0x06	Shutdown command	Ready to switch on
0x0F	Enable operation	Operation enabled

After the frequency converter is in RUN mode, the motor speed can be changed by writing the desired value to CiA-402 cl Target Velocity Data Object. More descriptive explanations of CiA-402 Control Word and CiA-402 Mode can be found from Chapter 7.2.17 and Chapter 7.3.1.

6.8 CONTROLLING THE MOTOR IN BYPASS MODE

In order to control the drive with the OPTEC Option Board, change the value of parameter Remote Control Place to Fieldbus control.

To switch the frequency converter to RUN mode, write the following commands to the Bypass Fixed Control Word Data Object.

Table 16. Motor startup sequence in bypass mode

Command	Description
0x04	Request fault reset from drive
0x01	Switch to RUN mode

After the frequency converter is in RUN mode, the motor speed can be controlled using the Bypass Speed SetPoint Value Data Object and the frequency converters internal values can be written through Process Data In 1-8 Data Objects. More descriptive explanations of Bypass General Status Word, Process Data In 1-8 and Bypass mode can be found from Chapter 7.2.12, Chapter 7.2.15 and Chapter 7.3.2.

6.9 ETHERCAT SLAVE INFORMATION (ESI) FILE

EtherCAT master device gets information on each slave in the network from the ESI file of the slave device. The ESI file has the necessary information for the configuration and running of the device.

6.9.1 OPTEC ESI FILE

In addition to configuration information, the ESI file for OPTEC has the object dictionary for all the available application parameters based on the configuration. The drive configuration consists of the drive type and application. The information in the ESI file must correspond to your drive configuration. You can download ESI files from Vacon website (www.vacon.com). Make sure you choose the ESI file that is intended for your drive configuration.

6.9.2 USING TWINCAT

1. Download the correct ESI file from Vacon website.
2. Save the file to C:\TwinCAT\Io\EtherCAT.
3. Restart TwinCAT.

When you run the board for the first time, you may have to rescan the boxes for TwinCAT to identify your drive configuration. If TwinCAT tells you that a new device type is found, and asks you if you want to use the online description, the ESI file does not contain the description for your configuration. If you do not have an ESI file available for your drive configuration, you can use the online description.

6.9.3 USING THE ONLINE DESCRIPTION

The online description file is generated from the information on the OPTEC board. The description file is limited to basic parameters common to all drive types. No application-specific information is included.

To use the online description file:

1. Remove all Vacon-related ESI files from C:\TwinCAT\Io\EtherCAT.
2. Rescan the boxes.
3. Click the Yes button on the dialogue box that opens.

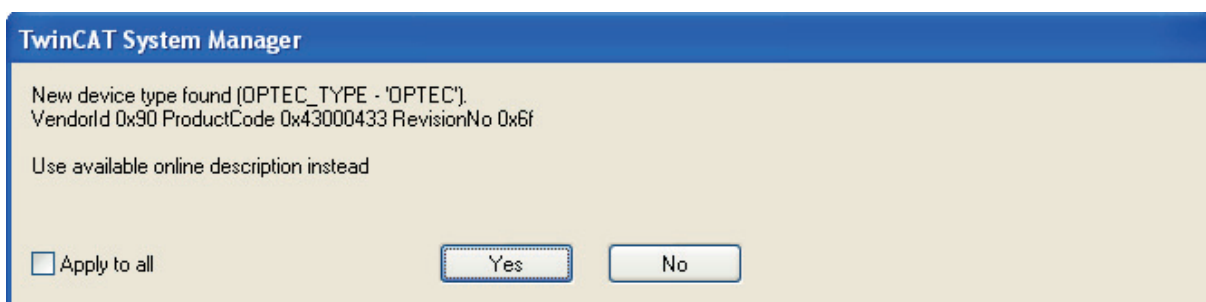

9461

4. You now have a basic OPTEC device with a limited object dictionary.

6.10 ESI FILE SELECTION

The configuration tool uses the vendor ID, the product code and revision to select the correct description of the slave device. For OPTEC, you must load different device descriptions depending on the drive configuration. The drive configuration consists of the drive type and the application. Each drive configuration has a different set of parameters available.

If the network has drives with different configurations, the ESI file selection must be set up in either of the two ways:

1. You can have a single description for all your configurations. The description can only include objects that are common to all the different drive configurations. Omit all objects that are specific to one drive configuration only. You can use either the OFF mode or the static mode. If you use the static mode, you can have only one description, and all drives must be set to use this description.
2. You can have multiple descriptions, one for each configuration. Every description must have a unique set of product code and revision number. You can use either the automatic mode or the static mode. In the automatic mode, the product code and revision number are generated automatically by the OPTEC board. If you use the static mode, you can have one description per configuration. Every drive with the same configuration must be set to use the same description.

6.10.1 ESI FILE SELECTION MODE

The configuration tool uses the vendor ID, product code and revision to choose the device description. The Vendor ID is fixed and cannot be changed. Use the product code and revision number to make multiple device descriptions. Object 0x5ff4 lets you choose how the parameters are generated.

5FF4:0	ESI File Selection Mode	RO	> 3 <
5FF4:01	Selection Mode	RW	OFF (0)
5FF4:02	Static Product Code	RW	0x00000000 (0)
5FF4:03	Static Revision Number	RW	0x0000 (0)

9456

The selection mode parameter in the sub-index 1 chooses the mode that is used. The available modes are OFF, Automatic and Static.

Mode	Value	Description
OFF	0	Automatic generation is switched off. The product code is set to the default value 0x4543 and the revision number is set to 1.
Automatic	1	The product code and revision number is generated by using information about the drive and the currently running application.
Static	2	The product code and revision number found in the sub-indexes 2 and 3 are used.

After you switch the device to a new mode, set the device to INIT state for the change to take effect. You can make the change of mode in any configuration tool, for example, in TwinCAT. The change of mode cannot be made in the operational state.

6.10.1.1 OFF mode

When you use the OFF mode, the product code and revision number must be set to 0x4543 and 1 respectively. You only have 1 device description available.

All device-specific objects that are accessed through CoE must be defined in the object dictionary. If you have more than 1 drive in the OFF mode in the network, and the drives do not use the same drive configuration, only objects that are common to all drives can be in the object dictionary. Do not use the OFF mode when you have different drive types and/or you run different applications.

6.10.1.2 Automatic mode

In the automatic mode, the OPTEC board generates a unique product code. The generated product code together with the revision number is used by the configuration tool to automatically choose the correct device description from the ESI file.

The product code depends on the drive type, and the type of the application the drive runs.

If you have access to the EtherCAT network, use the online description to find the product code and revision number of your drive configuration. See Chapter 6.9.3 "Using the online description".

Read the object 1018 sub-index 2 and 3 To find the product code and revision number, as shown below:

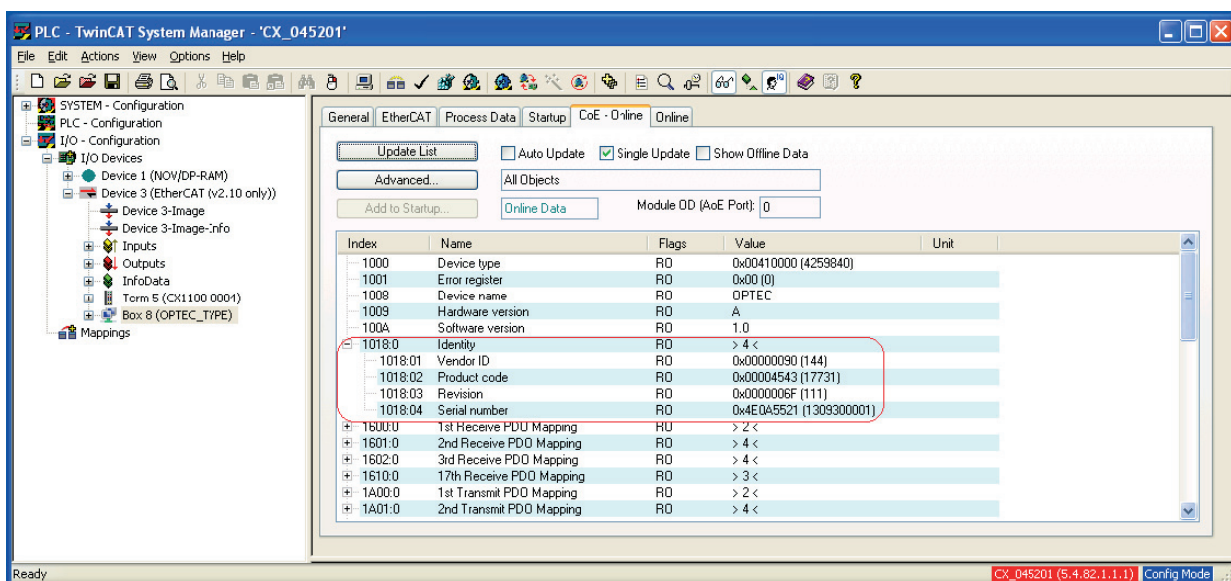

9458

If you do not have access to the online description, you can calculate the product code. The method varies depending on the drive family.

Table 17. Calculating the product code for devices in the V20 and V100 family

Bits	Description		
31-24	Drive family	Value	Description
	V20	0x43	Drive type identifier
	V100	0x4d	Drive type identifier
23-16	Not used		
15-0	Application identifier, which is the unique identification code of the application. The code shows in the name of the application installation file. For example, in the installation file AMF11234V567.vcx, 1234 is the application identification code.		

Table 18. Calculating the product code for devices in the NX family

Bits	Description		
31-24	Drive family	Value	Description
	NXP	0x50	Drive type identifier
	NXS	0x53	Drive type identifier
23	Not used		
Bits	Name	Description	
22-13	Country code	Calculate the value from the country code in the file name of the installation package. For example, in the file ASFIFF01V101.vcx, FI is the country code. Use a formula with the ASCII values: Country_code = (ASCII(F) – ASCII(A)) x 26 + (ASCII(I) – ASCII(A))	
12-10	Category	Category is the non-numerical part of the application ID. For example, in the file ASFIFF01V101.vcx, FF01 is the application ID and FF is the category.	
		Category	Value
		FF	0
		F	1
		BR	2
		EN	3
		E	4
		Q	5
9-0	Application identifier	Application identifier consists of the category part and the numerical part. For example, in the file ASFIFF01V101.vcx, FF01 is the application identifier. FF is the category and 01 is the numerical part. The total length of the application identifier is always 4 characters. A possible variation is, for example, F001.	

You must add a device description for every configuration to be supported. Add the new device to the Devices element in the ESI file.

Enter the calculated product code and the revision number of the application into the 'ProductCode' and 'RevisionNo' attributes in the Type element of the device, as shown below:

```

<Devices>
  <Device Physics="YY">
  <Device Physics="YY">
  <Device Physics="YY">
  <Device Physics="YY">
    <Type ProductCode="#00001234" RevisionNo="#x0321">MY_STATIC_DEVICE_TYPE</Type>
    <Name LcId="2057">MY_STATIC_DEVICE</Name>

```

9457

6.10.1.3 Static mode

In the static mode, you define the product code and revision number for the device description. Any value that is unique in the network is valid as a device description.

In the description file, enter the product code and revision number of your device description in the Device section.

```
<Devices>
  <Device Physics="YY">
  <Device Physics="YY">
  <Device Physics="YY">
  <Device Physics="YY">
    <Type ProductCode="#00001234" RevisionNo="#x0321">MY_STATIC_DEVICE_TYPE</Type>
    <Name LcId="2057">MY_STATIC_DEVICE</Name>
```

9460

Make sure the device is in the pre-operational state, and that the selection mode is set to either OFF or Automatic.

5FF4:0	ESI File Selection Mode	RD	> 3 <
5FF4:01	Selection Mode	RW	OFF (0)
5FF4:02	Static Product Code	RW	0x00000000 (0)
5FF4:03	Static Revision Number	RW	0x0000 (0)

9459

Write the product code and revision number to their respective objects.

5FF4:0	ESI File Selection Mode	RD	> 3 <
5FF4:01	Selection Mode	RW	OFF (0)
5FF4:02	Static Product Code	RW	0x00001234 (4660)
5FF4:03	Static Revision Number	RW	0x0321 (801)

9462

Change the selection mode to Static and rescan the network.

5FF4:0	ESI File Selection Mode	RD	> 3 <
5FF4:01	Selection Mode	RW	Static (2)
5FF4:02	Static Product Code	RW	0x00001234 (4660)
5FF4:03	Static Revisior Number	RW	0x0321 (801)

9463

7. ETHERCAT

The OPTEC Option Board offers data objects through EtherCAT by the process data image and by mailbox protocols. The supported mailbox protocols is CanOpen Over EtherCAT(CoE). The available data objects depend on the accessing method used.

The difference between the process data image and mailbox protocols are that the mailbox transfer is initiated only on demand and the process data image is constantly kept up-to-date between the EtherCAT Master and all EtherCAT slaves in the EtherCAT bus.

Figure 5. Communication between EtherCAT bus and Vacon drive

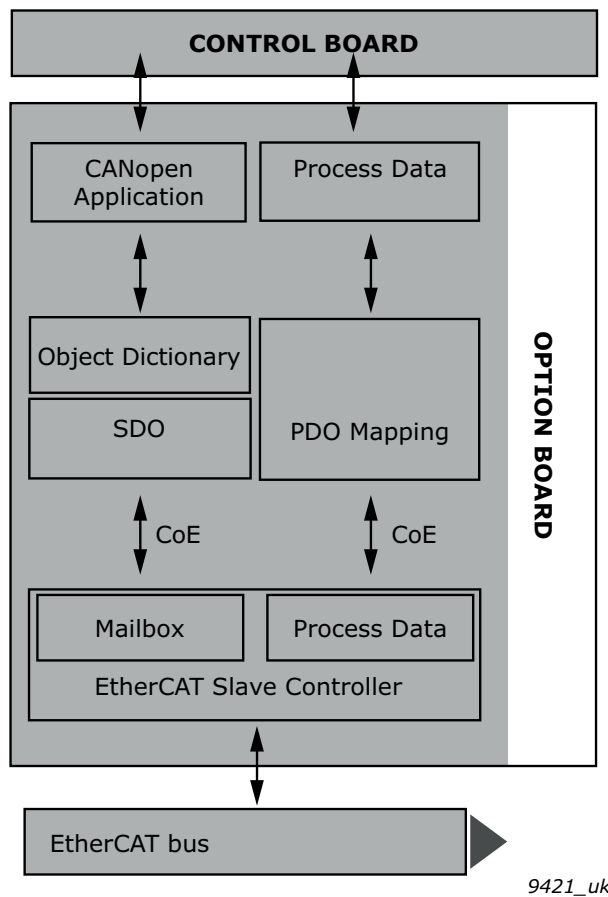

7.1 DATA OBJECT LIST

Data objects from index 1000h to 1018h are CANopen DS-301 specific and descriptions can be found from Chapter 8 "Appendix A: CANopen DS301 specific data object descriptions". Data objects from index 1C30h to 1C4Fh are EtherCAT sync manager specific.

Data objects from 2000h to 5EFFh are dynamically mapped, meaning that they are not defined by the option board. These objects are defined by the EtherCAT Master ESI configuration file and vary depending on the drive and application used. See Chapter 6.10 for more details.

Table 19. All data objects

Index: Sub-index	Name	Type	R/W	Description	
General Parameters					
1000	Device type	UINT32	RO	See Chapter 8 for description	
1001	Error register	UINT32	RO		
1008	Device Name	STRING8	RO		
1009	Hardware Version	STRING3	RO		
100A	Software version	STRING8	RO		
1018	0	Identity	Group		RO
	01	Vendor ID	UINT32		RO
	02	Product Code	UINT32		RO
	03	Revision	UINT32		RO
	04	Serial Number	UINT32		RO
Receive PDO Mapping Parameters					
1600	0	1st Receive PDO Mapping	Group	RO	EtherCAT process image Output objects
	01	CiA-402 Control word	UINT32	RO	
	02	CiA-402 vI Target Velocity	UINT32	RO	
1601	0	2nd Receive PDO Mapping	Group	RO	
	01	Drive Process Data In 1	UINT32	RO	
	02	Drive Process Data In 2	UINT32	RO	
	03	Drive Process Data In 3	UINT32	RO	
1602	04	Drive Process Data In 4	UINT32	RO	
	0	3rd Receive PDO Mapping	Group	RO	
	01	Drive Process Data In 5	UINT32	RO	
	02	Drive Process Data In 6	UINT32	RO	
1610	03	Drive Process Data In 7	UINT32	RO	
	04	Drive Process Data In 8	UINT32	RO	
	0	17th Receive PDO Mapping	Group	RO	
	01	Bypass Fixed Control Word	UINT32	RO	
	02	Bypass General Control Word	UINT32	RO	
	03	Bypass Speed Setpoint Value	UINT32	RO	
Transmit PDO Mapping Parameters					

Table 19. All data objects

Index: Sub-index		Name	Type	R/W	Description	
1A00	0	1st Transmit PDO Mapping	Group	RO	EtherCAT process image Input objects	
	01	CiA-402 Status Word	UINT32	RO		
	02	CiA-402 vl Velocity Actual Value	UINT32	RO		
1A01	0	2nd Transmit PDO Mapping	Group	RO		
	01	Drive Process Data out 1	UINT32	RO		
	02	Drive Process Data out 2	UINT32	RO		
	03	Drive Process Data out 3	UINT32	RO		
	04	Drive Process Data out 4	UINT32	RO		
1A02	0	3rd Transmit PDO Mapping	Group	RO		
	01	Drive Process Data out 5	UINT32	RO		
	02	Drive Process Data out 6	UINT32	RO		
	03	Drive Process Data out 7	UINT32	RO		
	04	Drive Process Data out 8	UINT32	RO		
1A10	0	4th Transmit PDO Mapping	Group	RO		
	01	Bypass Fixed Status Word	UINT32	RO		
	02	Bypass General Status Word	UINT32	RO		
	03	Bypass Speed Actual Value	UINT32	RO		
PDO Assign Parameters						
1C12	0	RxPDO assign	Group	RW		PDO assign outputs
	01	Sub-index 001	UINT16	RW		
	02	Sub-index 002	UINT16	RW		
	03	Sub-index 003	UINT16	RW		
	04	Sub-index 004	UINT16	RW		
1C13	0	TxPDO assign	Group	RW	PDO assign inputs	
	01	Sub-index 001	UINT16	RW		
	02	Sub-index 002	UINT16	RW		
	03	Sub-index 003	UINT16	RW		
	04	Sub-index 004	UINT16	RW		
Sync Manager Parameters						
1C32	0	SM Output parameters	Group	RO		
	01	Sync mode	UINT16	RW	Current output sync mode	
	04	Sync modes supported	UINT16	RO	Supported output sync modes	
1C33	0	SM Input parameters	Group	RO		
	01	Sync mode	UINT16	RW	Current input sync mode	
	04	Sync modes supported	UINT16	RO	Supported input sync modes	

Table 19. All data objects

Index: Sub-index		Name	Type	R/W	Description
Dynamic Manufacturer Specific Parameter Area					
2000					
5EFF					
Static Manufacturer Specific Parameters					
5FF3	0	Drive Information	Group	RO	
	01	Drive Serial Number	STRING20	RO	Serial number
	02	Drive Name	STRING40	RW	V100 drive name
5FF4	0	ESI File Selection Mode	Group	RO	
	01	Selection Mode	UINT16	RW	Selected mode
	02	Static Product Code	UINT32	RW	Static mode product code
	03	Static Revision Number	UINT16	RW	Static mode revision number
5FF5	0	Operating Energy	Group	RO	Access drive energy counters
	01	Energy	FLOAT32	RO	Total energy
	02	Trip Energy	FLOAT32	RO	Trip energy value
	03	Reset Trip Energy	UINT16	RW	Reset Trip Energy
5FF6	0	Trip Operating Time	Group	RO	
	01	Years	UINT16	RO	Trip operating years
	02	Days	UINT16	RO	Trip operating days
	03	Hours	UINT8	RO	Trip operating hours
	04	Minutes	UINT8	RO	Trip operating minutes
	05	Seconds	UINT8	RO	Trip operating seconds
	06	Total seconds	UINT32	RO	Total trip operating seconds
	07	Reset Trip Operating Time	UINT16	RW	Reset Trip Operating Time
5FF7	0	Operating Time	Group	RO	
	01	Years	UINT16	RO	Operating years
	02	Days	UINT16	RO	Operating days
	03	Hours	UINT8	RO	Operating hours
	04	Minutes	UINT8	RO	Operating minutes
	05	Seconds	UINT8	RO	Operating seconds
	06	Total seconds	UINT32	RO	Total operating seconds
5FF8	0	ParReadCoE	Group	RO	Parameter channel read
	01	ParReadID	UINT16	RW	Read ID
	02	ParReadIDValue	UINT32	RO	Read value
	03	ParReadSeqNo	UINT16	RO	Read sequence number
	04	ParReadIDStatus	INT8	RO	Read status

Table 19. All data objects

Index: Sub-index		Name	Type	R/W	Description
5FF9	0	ParWriteCoE	Group	RO	Parameter channel write
	01	ParWriteID	UINT16	RW	Write ID
	02	ParWriteIDValue	UINT32	RW	Write value
	03	ParWriteSeqNo	UINT16	RO	Write sequence number
	04	ParWriteIDStatus	INT8	RO	Write status
5FFA	0	Bypass Control	Group	RO	
	01	Bypass Fixed Control Word	UINT16	RW	Bypass mode control word
	02	Bypass General Control Word	UINT16	RW	Application specific control word
5FFB	0	Bypass Status	Group	RO	
	01	Bypass Fixed Status Word	UINT16	RO	Bypass mode status word
	02	Bypass General Status Word	UINT16	RO	Application specific status word
5FFC		Bypass Speed Setpoint Value	UINT16	RW	Bypass speed control
5FFD		Bypass Speed Actual Value	UINT16	RO	Bypass actual speed
5FFE	0	Drive Process Data In	Group	RO	Application specific
	01	Drive Process Data In 1	UINT16	RO	
	02	Drive Process Data In 2	UINT16	RO	
	03	Drive Process Data In 3	UINT16	RO	
	04	Drive Process Data In 4	UINT16	RO	
	05	Drive Process Data In 5	UINT16	RO	
	06	Drive Process Data In 6	UINT16	RO	
	07	Drive Process Data In 7	UINT16	RO	
	08	Drive Process Data In 8	UINT16	RO	
5FFF	0	Drive Process Data Out	Group	RO	Application specific
	01	Drive Process Data Out 1	UINT16	RO	
	02	Drive Process Data Out 2	UINT16	RO	
	03	Drive Process Data Out 3	UINT16	RO	
	04	Drive Process Data Out 4	UINT16	RO	
	05	Drive Process Data Out 5	UINT16	RO	
	06	Drive Process Data Out 6	UINT16	RO	
	07	Drive Process Data Out 7	UINT16	RO	
	08	Drive Process Data Out 8	UINT16	RO	
CiA-402 Parameters					
6040		Control Word	UINT16	RW	Control CiA-402 State Machine
6041		Status Word	UINT16	RO	Current CiA-402 state
6042		vI Target Velocity	INT16	RW	RPM-speed request

Table 19. All data objects

Index: Sub-index	Name	Type	R/W	Description
6043	vl Velocity Demand	INT16	RO	Ramp generator output scaled into RPM
6044	vl Velocity Actual Value	INT16	RO	Current RPM-speed
6046	0 vl Velocity Min Max Amount	Group	RO	
	01 vl Velocity Min Amount	UINT16	RW	Minimum RPM-speed
	02 vl Velocity Max Amount	UINT16	RW	Maximum RPM-speed
6048	0 vl Velocity Acceleration	Group	RO	Slope of the acceleration ramp
	01 Acceleration Delta Speed	UINT32	RW	
	02 Acceleration Delta Time	UINT16	RW	
6049	0 vl Velocity Deceleration	Group	RO	Slope of the deceleration ramp
	01 Deceleration Delta Speed	UINT32	RW	
	02 Deceleration Delta Time	UINT16	RW	
6061	Modes of Operation Display	INT16	RO	Current CiA-402 operation mode
6502	Supported Drive Modes	UINT16	RO	Supported CiA-402 drive

7.2 DATA OBJECT DESCRIPTIONS

This chapter explains thoroughly all the data objects mentioned in Chapter 7.1.

The table below explains for the format of the data object tables of the following chapters.

Table 20. Legend of Data Object description table

Index	Name of the Data Object		
	Valid in Mode	R/W	Accessible through
Index of the described data object.	States the OPTEC Option Board mode in which data of this object is valid: <ul style="list-style-type: none"> • Bypass = Data is valid when OPTEC is in Bypass mode • CiA-402 = Data is valid when OPTEC is in CiA-402 Mode 	States the access right of this data object: <ul style="list-style-type: none"> • R = Data object is Read-Only • RW = Data object is Writable and Read-able 	States the possible access methods for this data object <ul style="list-style-type: none"> • CoE-RxPDO = Data object is available through MailBox CoE Receive Process Data objects • CoE-TxPDO = Data object is available through Mailbox CoE Transmit Process Data objects • EtherCAT-Inputs = Data object is available through EtherCAT process image inputs • EtherCAT-Outputs = Data object is available through EtherCAT process image outputs • CoE-Not Mapped = Data object is available through CoE Not Mapped Data Objects

7.2.1 RXPDO ASSIGN

The RxPDO assign object is used to select the PDO content of each Receive PDO Mapping object. In OPTEC all of these indices are fixed, meaning that the content cannot be changed. All but the first sub-index are also mandatory, meaning that they cannot be disabled. The first sub-index, containing CiA-402 specific objects, can be disabled to enable Bypass mode. See Chapter 6.6 for more details.

RxPDO assign descriptions			
Index	Valid in Mode	R/W	Accessible through
1C12:0	Bypass, CiA-402	RW	CoE-Not Mapped

Sub-index	Name	Type	Access	Description
1C12:01	Sub-index 001	UINT16	RO	Fixed
1C12:02	Sub-index 002	UINT16	RO	Fixed, mandatory
1C12:03	Sub-index 003	UINT16	RO	Fixed, mandatory
1C12:04	Sub-index 004	UINT16	RO	Fixed, mandatory

7.2.2 TxPDO ASSIGN

The TxPDO assign object is used to select the PDO content of each Transmit PDO Mapping object. In OPTEC all of these indices are fixed, meaning that the content cannot be changed. All but the first sub-index are also mandatory, meaning that they cannot be disabled. The first sub-index, containing CiA-402 specific objects, can be disabled to enable Bypass mode. See Chapter 6.6 for more details.

TxPDO assign descriptions			
Index	Valid in Mode	R/W	Accessible through
1C13:0	Bypass, CiA-402	RW	CoE-Not Mapped

Sub-index	Name	Type	Access	Description
1C13:01	Sub-index 001	UINT16	RW	Fixed
1C13:02	Sub-index 002	UINT16	RW	Fixed, mandatory
1C13:03	Sub-index 003	UINT16	RW	Fixed, mandatory
1C13:04	Sub-index 004	UINT16	RW	Fixed, mandatory

7.2.3 SYNC MANAGER

These objects are used to set the inputs and outputs of the synchronisation parameters.

7.2.3.1 Sync mode

The status of the input and output parameters of the synchronisation manager. To identify the current synchronisation mode, read the objects 0x1c32 and 0x1c33. To select the synchronisation mode, write to these registers. OPTEC supports only the free run mode. If you write any other value than 0, an error occurs.

Sync mode descriptions			
Indices	Valid in Mode	R/W	Accessible through
1C32:01, 1C33:01	Bypass, CiA-402	RW	CoE-Not Mapped

1C32:01	1C33:01	Name	Description
1..	1..	Not used	Not supported
0	0	Free run mode	The EtherCAT communication and the application run independently of each other.

7.2.3.2 Sync modes supported

Supported sync modes can be determined by reading the logical high (1) bits from this object.

Sync Modes Supported descriptions			
Indices	Valid in Mode	R/W	Accessible through
1C32:04, 1C33:04	Bypass, CiA-402	RO	CoE-Not Mapped

Bit	Name	Description
15	Not in use	Not supported
14	Dynamic Cycle time	Not supported
2-13	Not in use	Not supported
1	Synchronous mode supported	Not supported
0	Free run mode supported	Supported

7.2.4 DRIVE INFORMATION

Use the object to read information from the drive. In a V100 device you can also use this object to read and write the name of the drive.

Drive Information descriptions			
Index	Valid in Mode	R/W	Accessible through
5FF3:0	Bypass, CiA-402	RO	CoE-Not Mapped

Sub-index	Name	Type	Access	Description
5FF5:01	Drive serial number	STRING20	RO	The serial number of the drive
5FF5:02	Drive name	STRING40	RW	The user-defined name of the drive. Supported only in V100 drives.

7.2.5 ESI FILE SELECTION MODE

Use the object to select the way that the OPTEC generates the product code and revision number for this device. The product code and revision number is used by the master device to recognise the slave.

Operating Energy descriptions			
Index	Valid in Mode	R/W	Accessible through
5FF4:0	Bypass, CiA-402	RO	CoE-Not Mapped

Sub-index	Name	Type	Access	Description
5FF4:01	Selection Mode	UINT16	RW	Selects the mode used to identify the slave description in the ESI file. The available modes are: OFF, Automatic and Static. After the device is switched to a new mode, the device must be set to INIT state for the change to take effect. See Chapter 6.10 "ESI file selection" for further information.
5FF4:02	Static Product Code	UINT32	RW	The product code when the static selection mode is used.
5FF4:03	Static Revision Number	UINT16	RW	The revision number when the static selection mode is used.

7.2.6 OPERATING ENERGY COUNTERS

This object is used to read the drive's energy counters and reset the trip energy counter.

Operating Energy descriptions			
Index	Valid in Mode	R/W	Accessible through
5FF5:0	Bypass, CiA-402	RO	CoE-Not Mapped

Sub-index	Name	Type	Access	Description
5FF5:01	Energy	FLOAT32	RO	Total Energy consumed
5FF5:02	Trip energy	FLOAT32	RO	Trip Energy counter
5FF5:03	Reset Trip energy	UINT16	RW	Reset Trip Energy counter by writing '1' to this sub-index

Note: Vacon 20 does not support resetting of Operating Energy Counter. Therefore writing 1 to index 5FF5:03 has no effect.

7.2.7 OPERATING TRIP TIME COUNTERS

This object is used to read and reset the drive's operating trip time counters.

Trip Operating Time descriptions			
Index	Valid in Mode	R/W	Accessible through
5FF6:0	Bypass, CiA-402	RO	CoE-Not Mapped

Sub-index	Name	Type	Access	Description
5FF6:01	Years	UINT16	RO	Trip counter value in years
5FF6:02	Days	UINT16	RO	Trip counter value in days
5FF6:03	Hours	UINT16	RO	Trip counter value in hours
5FF6:04	Minutes	UINT16	RO	Trip counter value in minutes
5FF6:05	Seconds	UINT16	RO	Trip counter value in seconds
5FF6:06	Total seconds	UINT16	RO	Total trip counter value in seconds
5FF6:07	Reset Trip Operating Time	UINT16	RW	Reset Trip Operating Time by writing '1' to this sub-index.

Note: Vacon 20 does not support resetting of Operating Trip Counter. Therefore writing 1 to index 5FF6:07 has no effect.

7.2.8 OPERATING TIME COUNTERS

This object is used to access the drive's operating time counters.

Operating Time descriptions			
Index	Valid in Mode	R/W	Accessible through
5FF7:0	Bypass, CiA-402	RO	CoE-Not Mapped

Sub-index	Name	Type	Access	Description
5FF7:01	Years	UINT16	RO	Time counter value in years
5FF7:02	Days	UINT16	RO	Time counter value in days
5FF7:03	Hours	UINT16	RO	Time counter value in hours
5FF7:04	Minutes	UINT16	RO	Time counter value in minutes
5FF7:05	Seconds	UINT16	RO	Time counter value in seconds
5FF7:06	Total seconds	UINT16	RO	Total time counter value in seconds

7.2.9 PARAMETER CHANNEL READ

This object is used to read drive specific parameters using the parameter ID. See Chapter 7.4.2 for an example on using this object.

ParReadCoE descriptions			
Index	Valid in Mode	R/W	Accessible through
5FF8:0	Bypass, CiA-402	RO	CoE-Not Mapped

Sub-index	Name	Type	Access	Description	
5FF8:01	ParReadID	UINT16	RW	ParReadIDStatus	
5FF8:02	ParReadIDValue	UINT16	RO	Parameter value	
5FF8:03	ParReadIDSeqNo	UINT16	RO	Parameter read sequence number. This value will increase by one for every successful operation	
5FF8:04	ParReadIDStatus	INT16	RO	Read Operation status	
				Return code	Description
				0	Read operation successful
				-2	Parameter ID not found
				-5	Internal communication error
				-6	Parameter type not supported for reading
				-9	Operation not supported in Fast Process Data Mode
-127	Undefined error				

7.2.10 PARAMETER CHANNEL WRITE

This object is used to write drive specific parameters using the parameter ID. See Chapter 7.4.3 for an example on using this object.

ParWriteCoE descriptions			
Index	Valid in Mode	R/W	Accessible through
5FF9:0	Bypass, CiA-402	RO	CoE-Not Mapped

Sub-index	Name	Type	Access	Description	
5FF9:01	ParWriteID	UINT16	RW	Parameter ID to write	
5FF9:02	ParWriteIDValue	UINT32	RW	Parameter value to write	
5FF9:03	ParWriteIDSeqNo	UINT16	RO	Parameter write sequence number. This value will increase by one for every successful operation	
5FF9:04	ParWriteIDStatus	INT16	RO	Write operation status	
				Return code	Description
				0	Read operation successful
				-1	Parameter is read only
				-2	Parameter ID not found
				-3	Value out of range
				-4	Parameter is locked by drive
				-5	Internal communication error
				-6	Parameter type not supported for writing
				-8	Internal communication timeout
-9	Operation not supported in Fast Process Data Mode				
-127	Undefined error				

7.2.11 BYPASS CONTROL

7.2.11.1 Bypass Fixed Control Word

Bypass fixed Control Word is used to control the frequency converter when the OPTEC Option Board is in Bypass Mode. Note that the Fixed Control Word might vary depending on the drive/application used.

Bypass Fixed Control Word field descriptions			
Index	Valid in Mode	R/W	Accessible through
5FFA:01	Bypass	RW	CoE-RxPDO, EtherCAT-Outputs

Bit(s)		Name	Description
13-15	na	Not in Use	Bits 13 through 15 are not in use.
12	ESTP *	Emergency Stop	Request fast as possible stop: • 0b1 = Emergency stop
11	JOG2 *	Jogging request	Select jogging with reference 2: • 0b1 = Select ref2 jogging
10	JOG1 *	Jogging request	Select jogging with reference 1: • 0b1 = Select ref1 jogging
9	BREF	Bus Reference	Force Reference to fieldbus: • 0b0 = Selected reference place • 0b1 = Force reference from fieldbus
8	BCTRL	Bus Control	Force fieldbus control active: • 0b0 = Selected control place • 0b1 = Force Fieldbus Control
7	ZREF *	Zero Ref	Force reference to zero: • 0b1 = Force reference to zero
6	FRMP *	Ramp Freeze	Freeze ramp generator: • 0b1 = Freeze ramp generator
5	ZRMP *	Zero Ramp	Force ramp to zero: • 0b1 = Ramp time to zero
4	STPM2 *	Stop Mode2	Stop mode ramping: • 0b1 = Stop By Ramp mode
3	STPM1 *	Stop Mode1	Stop mode coasting: • 0b1 = Coasting Stop Mode
2	FRST	Fault Reset	Request fault reset from drive: • 0b1 = Request reset from drive
1	DIR	Direction	Rotation direction: • 0b0 = Clockwise • 0b1 = Counterclockwise
0	STRT	Start / Stop	Start / Stop request: • 0b0 = Stop • 0b1 = Run

* Not supported in NX-drives

7.2.11.2 Bypass General Control Word

The functionality of Bypass General Control Word depends on the selected application.

Bypass General Control Word field descriptions			
Index	Valid in Mode	R/W	Accessible through
5FFA:02	Bypass	RW	CoE-RxPDO, EtherCAT-Outputs

Bit(s)	Name	Description
15-0		Application dependent, see application manual for more information.

7.2.12 BYPASS STATUS

7.2.12.1 Bypass Fixed Status Word

The manufacturer specific state of the frequency converter can be determined by reading the bit values of this object in Bypass Mode. Note that the Fixed Status Word might vary depending on the drive/application used.

Bypass Fixed Status Word descriptions			
Index	Valid in Mode	R/W	Accessible through
5FFB:01	Bypass	R	CoE-TxPDO, EtherCAT-Inputs

Bit(s)		Name	Description
13-15	na	Not in Use	Bits 13 through 15 are application-specific.
8-12	na	Not in Use	Bits 8 through 12 are currently not used.
7	FRDY	Flux Ready	Motor magnetization is ready: <ul style="list-style-type: none"> • 0b1 = Flux Ready
6	ZSPD	Zero speed	Motor is running on zero speed: <ul style="list-style-type: none"> • 0b1 = Zero speed condition
5	ATREF	At reference	Reference frequency is reached: <ul style="list-style-type: none"> • 0b1 = Reference reached
4	ALARM	Alarm	Alarm indication: <ul style="list-style-type: none"> • 0b1 = Frequency converter has active Alarm
3	FLT	Faulted	Drive fault indication: <ul style="list-style-type: none"> • 0b1 = Frequency converter has active fault
2	DIR	Direction	Motor running direction: <ul style="list-style-type: none"> • 0b0 = Clockwise • 0b1 = Counterclockwise
1	RUN	Run	Motor running information: <ul style="list-style-type: none"> • 0b0 = Stopped • 0b1 = Running
0	RDY	Ready	Drive readiness information: <ul style="list-style-type: none"> • 0b1 = Ready

7.2.12.2 Bypass General Status Word

The functionality of Bypass General Status Word depends on the selected application.

Bypass General Status Word descriptions			
Index	Valid in Mode	R/W	Accessible through
5FFB:02	Bypass	RO	CoE-TxPDO, EtherCAT-Inputs

Bit(s)		Name	Description
			Application dependent. See application manual for more information.

7.2.13 BYPASS SPEED SETPOINT VALUE

Bypass Speed SetPoint Value is used to set the speed of the frequency converter's motor in percentages, when the OPTEC Option Board is in Bypass Mode.

Bypass Speed SetPoint Value field descriptions (W)			
Index	Valid in Mode	R/W	Accessible through
5FFC	Bypass	RW	CoE-RxPDO, EtherCAT-Outputs

Bit(s)	Name	Description
0-15	Speed SetPoint Value	Speed reference. The spin direction is controlled by the direction bit in Bypass Fixed Control Word. Range: 0...10000 • 10000 = 100.00%

7.2.14 BYPASS SPEED ACTUAL VALUE

The percentage of Minimum and Maximum RPM speed of the frequency converter's motor can be read from this object. Actual speed in percentage. 0 and 100% correspond to minimum and maximum frequencies respectively.

Bypass Speed Actual Value field descriptions			
Index	Valid in Mode	R/W	Accessible through
5FFD	Bypass	RO	CoE-TxPDO, EtherCAT-Inputs

Bit(s)	Name	Description
0-15	Speed Actual Value	Motor actual speed. The spin direction is read in Bypass Fixed Status Word bit DIR. Range: 0...10000 • 10000 = 100.00%

7.2.15 PROCESS DATA IN

The Internal Values of the frequency converter can be written through these data objects. The behavior depends on the application that is currently active and running on the frequency converter. See application manual for more information.

Process Data In 1-8 (W)			
Indices	Valid in Mode	R/W	Accessible through
5FFE:1-8	Bypass, CiA-402	RW	CoE-RxPDO, EtherCAT-Outputs

7.2.16 PROCESS DATA OUT

The actual values from the frequency converter’s data can be read from these data objects. Which internal values of the frequency converter can be read from the each object depends on the application currently running in the frequency converter. See application manual for more information.

Process Data Out 1-8 descriptions			
Indices	Valid in Mode	R/W	Accessible through
5FFF:1-8	Bypass, CiA-402	RO	CoE-TxPDO, EtherCAT-Inputs

7.2.17 CiA-402 CONTROL WORD

The state of the frequency converter’s CiA-402 State machine can be changed by writing the desired bit to the logical high (1).

CiA-402 Control Word field descriptions			
Index	Valid in Mode	R/W	Accessible through
6040	CiA-402	RW	CoE-RxPDO, EtherCAT-Outputs

Bit(s)		Name	Description
12-15	na	Not Used	Bits 12 through 15 are not in use.
11	ar	Alarm reset	The rising edge resets the alarm.
10	r	Reserved	Bit 10 is not in use
9	oms	Operation mode specific	Bit 9 is not in use
8	h	Halt	Bit 8 is not in use.
7	fr	Fault reset	The rising edge resets the fault.
4-6	na	Not Used	Bits 4 through 6 are not in use.
3	eo	Enable operation	Start drive
2	qs	Quick stop	Stops the drive by using the drive- or application-specific stop function that is used as quick stop.
1	ev	Enable Voltage	Enables/Disables output voltage
0	so	Switch on	Enables the possibility to start the drive together with ev.

7.2.18 CiA-402 STATUS WORD

The CiA-402 State of the frequency converter can be determined from this object by reading the logical high bits.

CiA-402 Status word field descriptions			
Index	Valid in Mode	R/W	Accessible through
6041	CiA-402	RO	CoE-TxPDO, EtherCAT-Inputs

Bit(s)		Name	Description
15	na	Not in Use	Bit 15 is not used.
14	idm	Incorrect drive mode	Indicates that the drive is in incorrect "Control mode" for the used CiA-402 profile
12-13	oms	Operation mode specific	Bits 12 through 13 are not in use
10	tr	Target reached	Target velocity reached
9	rm	Remote	Indicates that the drive is controllable by Fieldbus.
8	na	Not in Use	Bit 8 not in use.
7	w	Warning	Frequency converter has active Alarm
6	sod	Switch on disabled	PDS switch on disable
5	qs	Quick stop	PDS quick stop active
4	ve	Voltage enabled	Voltage is enabled
3	f	Fault	PDS Fault (Indicates fault condition)
2	oe	Operation enabled	PDS operation enabled (drive is running)
1	so	Switched on	PDS switched on
0	rtso	Ready to switch on	PDS ready to switch on

7.2.19 CiA-402 vL TARGET VELOCITY

RPM speed request for the frequency converter's motor in revolutions per minute. A negative value means that the motor is requested to run counterclockwise.

CiA-402 vL Target Velocity field descriptions			
Index	Valid in Mode	R/W	Accessible through
6042	CiA-402	RW	CoE-RxPDO, EtherCAT-Outputs

Bit(s)		Name	Description
0-15		Target Velocity	Range -32768...32767 RPM

7.2.20 CiA-402 vL VELOCITY DEMAND

The value of the ramp generator output scaled into RPM. The actual value in RPM of the frequency converter's motor rotation. A negative value means that the motor is running counterclockwise.

CiA-402 vL Velocity Demand descriptions			
Index	Valid in Mode	R/W	Accessible through
6043	CiA-402	RO	CoE-Not Mapped

Bit(s)		Name	Description
0-15		Velocity Demand	Range -32768...32767

7.2.21 CiA-402 vL VELOCITY ACTUAL VALUE

The RPM speed of the frequency converter’s motor can be read from this object. A negative value means that the motor is running counterclockwise.

CiA-402 vL Velocity Actual Value field descriptions			
Index	Valid in Mode	R/W	Accessible through
6044	CiA-402	R	CoE-TxPDO, EtherCAT-Inputs

Bit(s)	Name	Description
0-15	Velocity Actual Value	Range -32768...32767

7.2.22 CiA-402 vL VELOCITY MIN MAX AMOUNT

7.2.22.1 CiA-402 vL Velocity Min Amount

Minimum RPM speed of the frequency converter’s motor. The motor runs on speed defined here when the CiA-402 cl Target Velocity is set to 0.

CiA-402 vL Velocity Min Amount descriptions			
Index	Valid in Mode	R/W	Accessible through
6046:01	CiA-402	RW	CoE-Not Mapped

Bit(s)	Name	Description
0-31	Velocity Min Amount	Range 0...4294967296

7.2.22.2 CiA-402 vL Velocity Max Amount

Maximum RPM speed of frequency converter’s motor.

CiA-402 vL Velocity Max Amount descriptions			
Index	Valid in Mode	R/W	Accessible through
6046:02	CiA-402	RW	CoE-Not Mapped

Bit(s)	Name	Description
0-31	Velocity Max Amount	Range 0...4294967296

7.2.23 CiA-402 vL VELOCITY ACCELERATION

This object indicates the configured delta speed and delta time of the slope of the acceleration ramp.

CiA-402 vL Velocity Acceleration descriptions			
Index	Valid in Mode	R/W	Accessible through
6048:0	CiA-402	RO	CoE-Not Mapped

Sub-index	Name	Type	Access	Description
6048:01	Acceleration Delta Speed	UINT32	RW	Defines the maximum change of RPM the motor will accelerate during the time specified in Acceleration Delta Time.
6048:02	Acceleration Delta Time	UINT16	RW	Defines the time (in seconds) in which the RPM of the motor will accelerate the amount specified in Acceleration Delta Speed.

7.2.24 CiA-402 vL VELOCITY DECELERATION

This object indicates the configured delta speed and delta time of the slope of the deceleration ramp.

CiA-402 vL Velocity Deceleration descriptions			
Index	Valid in Mode	R/W	Accessible through
6049:0	CiA-402	RO	CoE-Not Mapped

Sub-index	Name	Type	Access	Description
6049:01	Deceleration Delta Speed	UINT32	RW	Defines the maximum change of RPM the motor will decelerate during the time specified in Deceleration Delta Time.
6049:02	Deceleration Delta Time	UINT16	RW	Defines the time (in seconds) in which the RPM of the motor will decelerate the amount specified in Deceleration Delta Speed.

7.2.25 CiA-402 MODES OF OPERATION DISPLAY

The current CiA-402 operation mode can be determined by reading the Integral value of this object. See the table below for more details.

CiA-402 Modes of operation Display descriptions			
Index	Valid in Mode	R/W	Accessible through
6061	Bypass, CiA-402	RO	CoE-Not Mapped

Value	Name	Description
-128 to -2	Manufacturer-specific operation modes	Not supported
-1	Bypass mode	Manufacturer-specific Bypass mode
0	No mode	No mode is selected
+1	Profile position mode	Not supported
+2	Velocity mode	Used to control the velocity of the drive with no special regard to the position.
+3	Profile velocity mode	Not supported
+4	Torque profile mode	Not supported
+5	Reserved	Not supported
+6	Homing mode	Not supported
+7	Interpolated position mode	Not supported
+8	Cyclic sync position mode	Not supported
+9	Cyclic sync velocity mode	Not supported
+10	Cyclic sync torque mode	Not supported
+11 to +127	Reserved	

7.2.26 CiA-402 SUPPORTED DRIVE MODES

Supported CiA-402 drive modes can be determined by reading the logical high (1) bits from this object.

CiA-402 Supported Drive Modes descriptions			
Index	Valid in Mode	R/W	Accessible through
6502	Bypass, CiA-402	RO	CoE-Not Mapped

Bit(s)		Name	Description
31	ms	Manufacturer specific	Supported
30-16	na	Not in use	Reserved for manufacturer specific modes
15-10	r	Reserved	
9	cst	Cyclic sync torque mode	Not supported
8	csv	Cyclic sync velocity mode	Not supported
7	csp	Cyclic sync position mode	Not supported
6	lp	Interpolated position mode	Not supported
5	hm	Homing mode	Not supported
4	r	Reserved	
3	tq	Torque profile mode	Not supported
2	pv	Profile velocity mode	Not supported
1	vl	Velocity mode	Supported
0	pp	Profile position mode	Not supported

7.3 OPTEC MODES

The OPTEC Option Board has two modes: CiA-402 and Bypass mode. By default, the option board is set to CiA-402 mode.

7.3.1 CiA-402 MODE

The OPTEC Option Board is set by default to this mode. In CiA-402 mode, the frequency converter can be controlled using the CiA-402 Drive profile. The following data objects are usable in CiA-402 mode:

Table 21. Data objects available in CiA-402 mode

Data object Name	R/W
CiA 402 Control Word	RW
CiA 402 vl Target Velocity	RW
Process Data Out 1 - 8	R
Process Data In 1-8	RW
CiA 402 Status Word	R
CiA 402 vl Velocity Actual Value	R
CiA-402 vl Velocity Demand	R
CiA-402 Modes Of Operation Display	R
CiA-402 Supported Drive Modes	R
CiA-402 vl Velocity Min Amount	RW
CiA-402 vl Velocity Max Amount	RW
Acceleration CiA-402 Delta Speed	RW
Acceleration CiA-402 Delta Time	RW
Deceleration CiA-402 Delta Speed	RW
Acceleration CiA Delta Time	RW
Quick Stop CiA-402 Delta Speed	RW
Acceleration CiA-402 Delta Time	RW

Data objects **CiA-402 Control Word** and **CiA-402 Status Word** can be used to control the frequency converter's CiA-402 state machine and to read the state of the frequency converter's CiA-402 State machine. The possible CiA-402 State machine states and transitions can be seen from Figure 7. The state of the frequency converter's CiA-402 state machine can be changed by writing the corresponding bits to **CiA 402 Control Word** data object. The needed bit values for each command can be seen from the Figure 6.

Command	Bits of the controlword					Transitions
	Bit 7	Bit 3	Bit 2	Bit 1	Bit 0	
Shutdown	0	X	1	1	0	2,6,8
Switch on	0	0	1	1	1	3
Switch on + enable operation	0	1	1	1	1	3 + 4 (NOTE)
Disable voltage	0	X	X	0	X	7,9,10,12
Quick stop	0	X	0	1	X	7,10,11
Disable operation	0	0	1	1	1	5
Enable operation	0	1	1	1	1	4,16
Fault reset		X	X	X	X	15
NOTE Automatic transition to Enable operation state after executing SWITCHED ON state functionality.						9422_uk

Figure 6. CiA-402 Control word commands

For example **CiA-402 Control Word** data object value for *Fault reset command* would be 0x80.

If CiA-402 mode is enabled, the state machine will always follow the state of the drive. However the state machine is controllable via CiA-402 Control Word only if Remote Control Place is set to Field-bus control .

If Control mode is not set to speed control, CiA-402 vl Target Velocity will not work as intended. CiA-402 Status Word bit 14 (idm) is set if drive is not in correct control mode. In NXP Closed loop speed control can be also used.

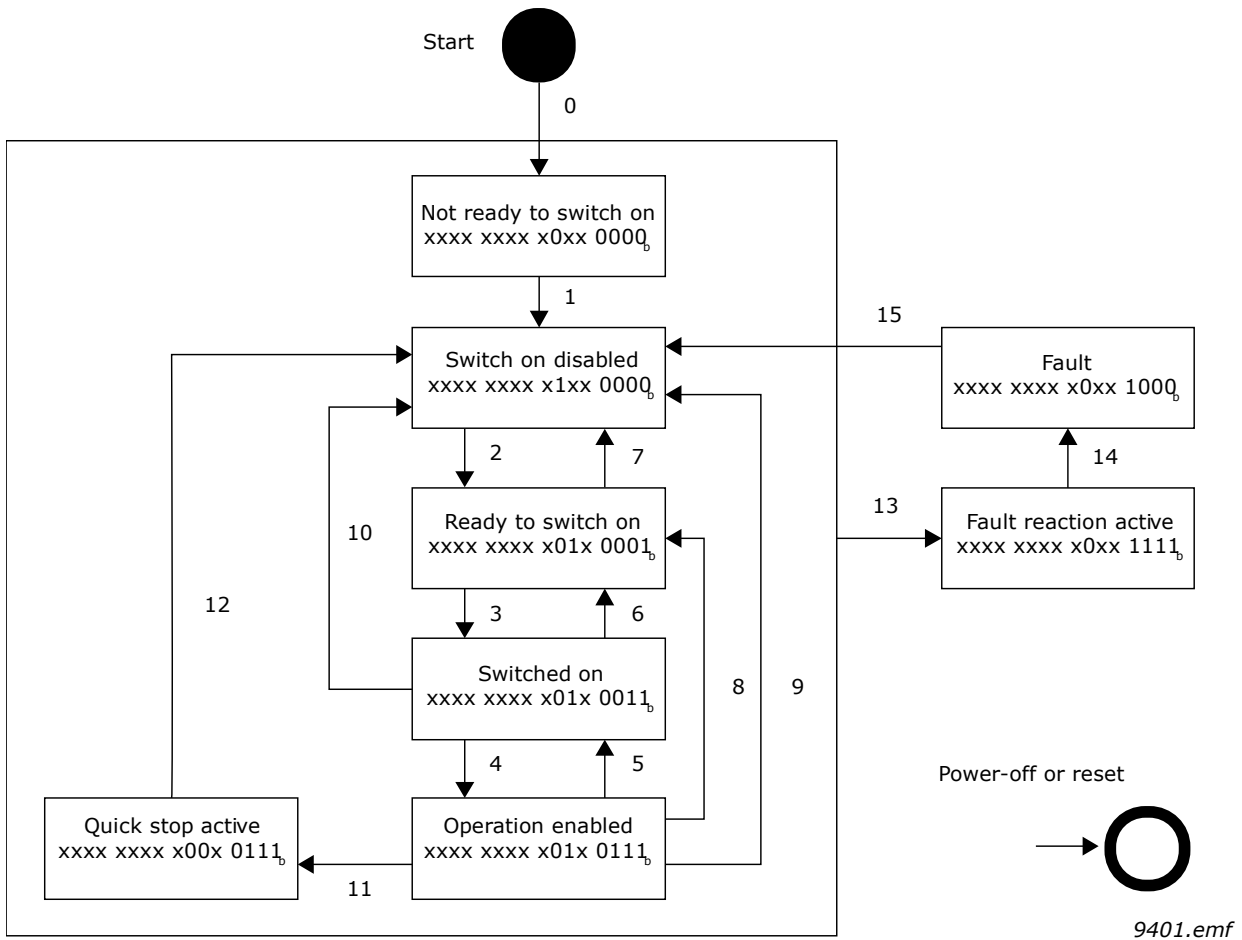

Figure 7.CiA-402 States

The table below explains the actions taken in different state transitions and which event triggers which state transition. If the used drive/application does not support different stop bits in Fixed Control Word, the stop method will always be according to set stop function.

Table 22. State transition events and actions

Transition	Event(s)	Action(s)
0	Automatic transition after power-on or reset	Self-initialization is performed
1	Automatic transition after drive status is 'ready'	None
2,6	Shutdown command	None
3	Switch on command	None
4	Enable operation command	Drive function is enabled
5	Disable operation command	Drive function is disabled
7	Disable voltage or quick stop command	None
8	Shutdown command	Stop by ramp /stop function
9	Disable voltage command	Stop by coast / stop function
10, 12	Disable voltage command	None
11	Quick stop command	Quick stop / stop function

Table 22. State transition events and actions

Transition	Event(s)	Action(s)
13	Fault signal	Go to fault state and stop by stop function
14	Automatic transition	None
15	Fault reset command	Reset fault if no fault currently exists on drive

Current CiA-402 state can be determined by reading the value of CiA 402 Status Word Data Object and comparing the value of bits to the table below.

Table 23. CiA-402 Status Word bits

Statusword	PDS FSA state
xxxx xxxx x0xx 0000 _b	Not ready to switch on
xxxx xxxx x1xx 0000 _b	Switch on disabled
xxxx xxxx x01x 0001 _b	Ready to switch on
xxxx xxxx x01x 0011 _b	Switched on
xxxx xxxx x01x 0111 _b	Operation enabled
xxxx xxxx x00x 0111 _b	Quick stop active
xxxx xxxx x0xx 1111 _b	Fault reaction active
xxxx xxxx x0xx 1000 _b	Fault

7.3.2 BYPASS MODE

Bypass mode is an optional mode for controlling the frequency converter with the OPTEC Option Board. In Bypass mode, it is possible to write data values of the frequency converter through Process Data In 1-8. The valid data objects in Bypass mode can be seen from Table 24.

Table 24. Data objects valid in Bypass mode

Data object Name	R/W
Bypass Fixed Control Word	RW
Bypass General Control Word	RW
Bypass Speed Setpoint Value	RW
Process Data In 1 - 8	RW
Process Data Out 1 - 8	R
CiA-402 Modes Of Operation Display	R
Bypass Fixed Status	R
Bypass General Status	R
Bypass Speed Actual Value	R

In Bypass mode, the frequency converter can be controlled using the data objects Bypass Fixed Control Word and Bypass General Control Word.

For instructions on switching to the Bypass Mode, see Chapter 6 "Commissioning".

7.3.3 NXP FAST PROCESS DATA MODE

Some applications support Fast Process Data Mode (FPDM). In this mode, the process data is transferred at a higher rate. The cost of using this mode is that drive parameters no longer can be accessed through service data. Since drive parameters cannot be accessed through service data, you can only use service data to switch to and not from FPDM. This also means that only bypass mode is supported and CiA 402 mode is not supported. To switch back to normal mode you will have to use the panel or PC-link. The panel or PC-link can also be used to switch to FPDM.

7.3.3.1 Switching to FPDM

Only NXP drives support FPDM. The drive needs to be running an application supporting it. Make sure that your drive is running an application that supports the FPDM. To check whether or not the used application supports FPDM, see Control Slot selector in the application manual. If your application supports FPDM, this parameter offers the choice to use the mode. A part of the Vacon Advanced Application manual describing the Control Slot selector can be found in the figure below.

P2.13.20 Control Slot selector **ID1440** "ControlSlotSel."

This parameter defines which slot is used as the main control place when two fieldbus boards have been installed in the drive. When values 6 or 7 are selected, the drive uses the Fast Profibus profile. When the Fast Profibus profile is used type 'B' boards or other C type boards cannot be used.

Note: Set first the Slave Address and the PPO type before selecting the Fast Profibus mode.

- 0 = All slots
- 4 = Slot D
- 5 = Slot E
- 6 = Slot D, Fast Profibus support
- 7 = Slot E, Fast Profibus support

11430_00

In this case, use parameter P2.13.20 from the panel or write to ID1440 using parameter channel. Depending in which slot the option board is placed write 6 or 7 to switch FPDM on or write 0 to switch FPDM off.

7.4 ACCESSING DRIVE PARAMETERS

Some parameters are available for reading and writing as objects based on the parameter ID. These objects are mapped in the manufacturers specific area between 2000h and 5EFFh. ID's are mapped with their ID number at the base address starting from 2000h. For example ID 103(67h) acceleration time is found at 2000h + 67h = 2067h. The available parameters are application dependent.

7.4.1 ERROR CODES

If the reading or writing an object fails, an error message appears. The corresponding error messages are explained in the table below.

Table 25. Object error messages

Code	Message	Description
0x06020000	Object does not exist in the object dictionary.	This object is invalid for this drive or application
0x05040000	SDO protocol timed out.	The option board timed out when trying to access the parameter
0x08000021	Data cannot be transferred or stored to the application because of local control	Parameter is locked
0x08000022	Data cannot be transferred or stored to the application because of the present device state.	The Control is busy. No data can currently be read or stored.
0x06010002	Attempt to write a read only object.	The parameter is read only
0x06090030	Value range of parameter exceeded (only for write access).	Attempted to write outside parameter valid range.

7.4.2 EXAMPLE 1: READING ID 103 'ACCELERATION TIME' USING THE PARAMETER CHANNEL

1

In TwinCAT's CoE -Online tab, find the object 5FF8 and expand the tree view.

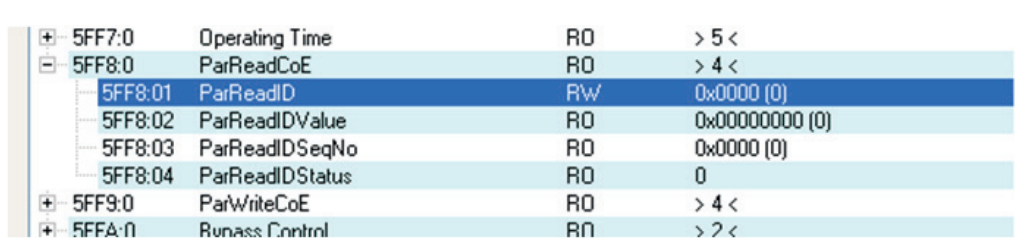

11300_00

2

Double-click sub-index 5FF8:01 ParReadID and enter the acceleration time ID 103 in the dialog. Click OK.

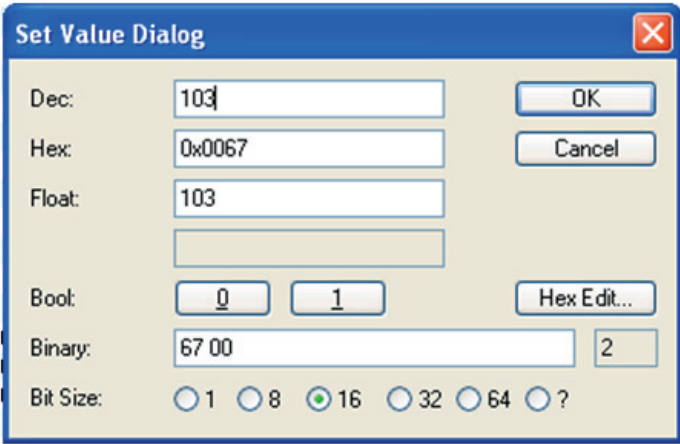

11301_00

3

To indicate an executed operation, the sub-index 5FF8:03 ParReadIDSeqNo is increased by one and the status of the write has been updated to sub-index 5FF9:04 ParReadIDStatus.

The status 0 indicates a successful read, as explained in Chapter 7.2.9 "Parameter Channel Read".

7.4.3 EXAMPLE 2: WRITING ID 103 'ACCELERATION TIME' USING THE PARAMETER CHANNEL

1

In TwinCAT's CoE -Online tab, find the object 5FF9 ParWriteCoE and expand the tree view.

5FF7:0	Operating Time	RO	> 5 <
5FF8:0	ParReadCoE	RO	> 4 <
5FF8:01	ParReadID	RW	0x0000 (0)
5FF8:02	ParReadIDValue	RO	0x00000000 (0)
5FF8:03	ParReadIDSeqNo	RO	0x0000 (0)
5FF8:04	ParReadIDStatus	RO	0
5FF9:0	ParWriteCoE	RO	> 4 <
5FFA:0	Runass Control	RO	> 2 <

11300_00

2

Double-click sub-index 5FF9:01 ParWritelD and enter the acceleration time ID 103 in the dialog. Click OK.

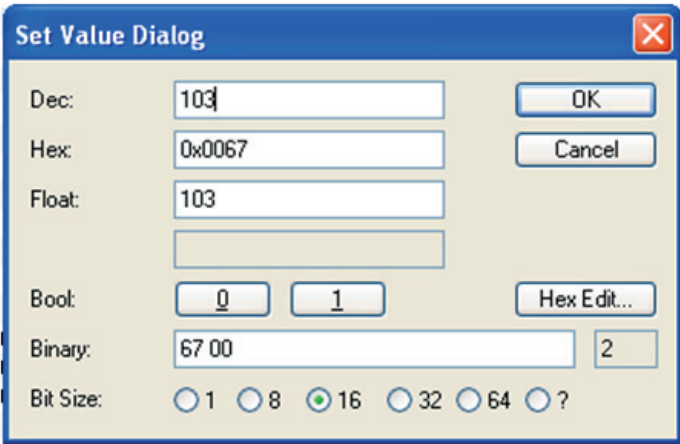

11301_00

3

The ID is now selected for writing.

+	5FF8:0	ParReadCoE	RO	> 4 <
-	5FF9:0	ParWriteCoE	RO	> 4 <
	5FF9:01	ParWritelD	RW	0x0067 (103)
	5FF9:02	ParWritelDValue	RW	0x00000000 (0)
	5FF9:03	ParWritelDSeqNo	RO	0x0000 (0)
	5FF9:04	ParWritelDStatus	RO	0

11302_00

4

Double-click sub-index 5FF9:02 ParWritelDValue. Enter the new acceleration time 1100 in the dialog. Click OK. The value is written to the drive.

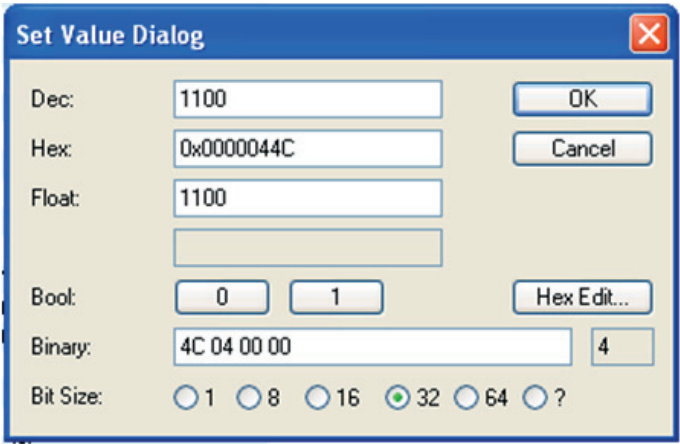

11303_00

5

To indicate an executed operation, the sub-index 5FF9:03 ParWriteIDSeqNo is increased by one and the status of the write has been updated to sub-index 5FF9:04 ParWriteIDStatus.

The status 0 indicates a successful write.

+	5FF8:0	ParReadCoE	RO	> 4 <
-	5FF9:0	ParWriteCoE	RO	> 4 <
	5FF9:01	ParWriteID	RW	0x0067 (103)
	5FF9:02	ParWriteIDValue	RW	0x0000044C (1100)
	5FF9:03	ParWriteIDSeqNo	RO	0x0001 (1)
	5FF9:04	ParWriteIDStatus	RO	0
+	5FFA:0	Bypass Control	RO	> 2 <

11304_00

6

To verify that the value was written correctly, the ID can be read by following the steps in the reading example in Chapter 7.4.2.

7.4.4 EXAMPLE 3: ATTEMPTING TO WRITE AN INVALID VALUE USING THE PARAMETER CHANNEL

1

Double-click sub-index 5FF9:02 ParWriteIDValue. Enter the new acceleration time 31000 in the dialog.

11305_00

2

Click OK. The option board now attempts to write the new value to the drive.

3

The sequence number increases by one to indicate that the operation was executed. The status word indicates that the operation failed (the status is not 0).

-	5FF9:0	ParWriteCoE	RO	> 4 <
	5FF9:01	ParWriteID	RW	0x0067 (103)
	5FF9:02	ParWriteIDValue	RW	0x00007918 (31000)
	5FF9:03	ParWriteIDSeqNo	RO	0x0005 (5)
	5FF9:04	ParWriteIDStatus	RO	-3

11306_00

4

Check the object description in Chapter 7.2.10. It shows that the value in step 1 is out of range for this particular parameter.

7.4.5 EXAMPLE 4: WRITING TO PARAMETER USING CoE OBJECT LIST

1	<p>To write a new value to the parameter, double-click the object in TwinCAT.</p> <table border="1" style="width: 100%; border-collapse: collapse;"> <tr><td>2065</td><td>Min Frequency</td><td>RW</td><td>0x0000 (0)</td></tr> <tr><td>2066</td><td>Max Frequency</td><td>RW</td><td>0x1388 (5000)</td></tr> <tr style="background-color: #e0f0ff;"><td>2067</td><td>Accel Time 1</td><td>RW</td><td>0x0BB8 (3000)</td></tr> <tr><td>2068</td><td>Decel Time 1</td><td>RW</td><td>0x001E (30)</td></tr> <tr><td>2069</td><td>Preset Speed 1</td><td>RW</td><td>1000</td></tr> <tr><td>206A</td><td>Preset Speed 2</td><td>RW</td><td>1500</td></tr> </table> <p style="text-align: right; font-size: 10pt;">11307_00</p>	2065	Min Frequency	RW	0x0000 (0)	2066	Max Frequency	RW	0x1388 (5000)	2067	Accel Time 1	RW	0x0BB8 (3000)	2068	Decel Time 1	RW	0x001E (30)	2069	Preset Speed 1	RW	1000	206A	Preset Speed 2	RW	1500				
2065	Min Frequency	RW	0x0000 (0)																										
2066	Max Frequency	RW	0x1388 (5000)																										
2067	Accel Time 1	RW	0x0BB8 (3000)																										
2068	Decel Time 1	RW	0x001E (30)																										
2069	Preset Speed 1	RW	1000																										
206A	Preset Speed 2	RW	1500																										
2	<p>Enter a new value and click OK.</p> <div style="border: 1px solid gray; padding: 10px; width: fit-content; margin: 0 auto;"> <p>Set Value Dialog ✖</p> <p>Dec: <input type="text" value="3100"/> OK</p> <p>Hex: <input type="text" value="0x0C1C"/> Cancel</p> <p>Float: <input type="text" value="3100"/></p> <p>Bool: <input type="button" value="0"/> <input type="button" value="1"/> Hex Edit...</p> <p>Binary: <input type="text" value="1C 0C"/> 2</p> <p>Bit Size: <input type="radio"/> 1 <input type="radio"/> 8 <input checked="" type="radio"/> 16 <input type="radio"/> 32 <input type="radio"/> 64 <input type="radio"/> ?</p> </div> <p style="text-align: right; font-size: 10pt;">11308_00</p>																												
3	<p>If the operation is successful, you see the updated value.</p> <table border="1" style="width: 100%; border-collapse: collapse;"> <tr><td>2053</td><td>Total Current</td><td>HU</td><td>0x000C (12)</td></tr> <tr><td>2065</td><td>Min Frequency</td><td>RW</td><td>0x0000 (0)</td></tr> <tr><td>2066</td><td>Max Frequency</td><td>RW</td><td>0x1388 (5000)</td></tr> <tr style="background-color: #e0f0ff;"><td>2067</td><td>Accel Time 1</td><td>RW</td><td>0x0C1C (3100)</td></tr> <tr><td>2068</td><td>Decel Time 1</td><td>RW</td><td>0x001E (30)</td></tr> <tr><td>2069</td><td>Preset Speed 1</td><td>RW</td><td>1000</td></tr> <tr><td>206A</td><td>Preset Speed 2</td><td>RW</td><td>1500</td></tr> </table> <p style="text-align: right; font-size: 10pt;">11309_00</p>	2053	Total Current	HU	0x000C (12)	2065	Min Frequency	RW	0x0000 (0)	2066	Max Frequency	RW	0x1388 (5000)	2067	Accel Time 1	RW	0x0C1C (3100)	2068	Decel Time 1	RW	0x001E (30)	2069	Preset Speed 1	RW	1000	206A	Preset Speed 2	RW	1500
2053	Total Current	HU	0x000C (12)																										
2065	Min Frequency	RW	0x0000 (0)																										
2066	Max Frequency	RW	0x1388 (5000)																										
2067	Accel Time 1	RW	0x0C1C (3100)																										
2068	Decel Time 1	RW	0x001E (30)																										
2069	Preset Speed 1	RW	1000																										
206A	Preset Speed 2	RW	1500																										
4	<p>If the operation is unsuccessful, the object value is not updated and there is an error message in the logger output describing the type of error.</p> <table border="1" style="width: 100%; border-collapse: collapse;"> <thead> <tr> <th style="width: 15%;">Server (Port)</th> <th style="width: 20%;">Timestamp</th> <th>Message</th> </tr> </thead> <tbody> <tr> <td style="color: red;">● (65535)</td> <td>10/23/2013 2:59:55 PM 996...</td> <td>'Box 1 (OPTEC_TYPE)' (1001): CoE ('InitDown' 0x2067:00) - SDO Abort ('Unsupported access to an object.', 0x06010000).</td> </tr> <tr> <td colspan="3" style="padding-top: 5px;">ready</td> </tr> </tbody> </table> <p style="text-align: right; font-size: 10pt;">11431_00</p>	Server (Port)	Timestamp	Message	● (65535)	10/23/2013 2:59:55 PM 996...	'Box 1 (OPTEC_TYPE)' (1001): CoE ('InitDown' 0x2067:00) - SDO Abort ('Unsupported access to an object.', 0x06010000).	ready																					
Server (Port)	Timestamp	Message																											
● (65535)	10/23/2013 2:59:55 PM 996...	'Box 1 (OPTEC_TYPE)' (1001): CoE ('InitDown' 0x2067:00) - SDO Abort ('Unsupported access to an object.', 0x06010000).																											
ready																													

8. APPENDIX A: CANOPEN DS301 SPECIFIC DATA OBJECT DESCRIPTIONS

Table 26. CANopen DS301 specific data object descriptions

Name	Index	Object code	Data type	Access	PDO-mapping	Default value	
Device type	1000h	Variable	UDINT	RO	No	00010192h	The device type specifies the kind of device. The lower 16 bit contain the device profile number and the upper 16 bit additional information.
Error register	1001h	Variable	USINT	RO	No	0	Eight bit filed representing the current error types. See Chapter 8.1 for details.
Manufacturer device name	1008h	Variable	VISIBLE STRING	RO	No	"OPTEC"	This object contains the manufacturer device name.
Manufacturer Hardware Version	1009h	Variable	VISIBLE STRING	RO	No	"AP1"	This object contains the version number of the manufacturer's hardware.
Manufacturer software version	100Ah	Variable	VISIBLE STRING	RO	No	---	This object contains the version identification of the manufacturer's software.
Identity object	1018h:00	Record	USINT	RO	No	4	This object contains general information about the device.
Vendor ID	1018h:01	Variable	UDINT	RO	No	00000090h	Contains a unique value allocated to each manufacturer.
Product code	1018h:02	Variable	UDINT	RO	No	---	Identifies the manufacturer specific product code (device version).
Revision number	1018h:03	Variable	UDINT	RO	No	00000001h	Contains the revision number. Bit 31-16 is the major revision number and bit 15-0 the minor revision number.
Serial number	1018h:04	Variable	UDINT	RO	No	---	Identifies a manufacturer specific serial number.

8.1 OBJECT 1001H: ERROR REGISTER

The error register is a field of 8 bits, each for a certain error type. If an error occurs, the corresponding error bit is set.

Table 27.

Bit	Meaning
0	generic error
1	current
2	voltage
3	temperature
4	communication error (overrun, error state)
5	device profile specific*
6	Reserved*
7	manufacturer specific*

* Not used/supported

9. APPENDIX B: DEVICE PROFILE FOR DRIVES

The Vacon EtherCAT Option Board follows the Drive device profile DSP-402. The Velocity mode is supported.

Figure 8. Basic Device Control and Device Data Interface

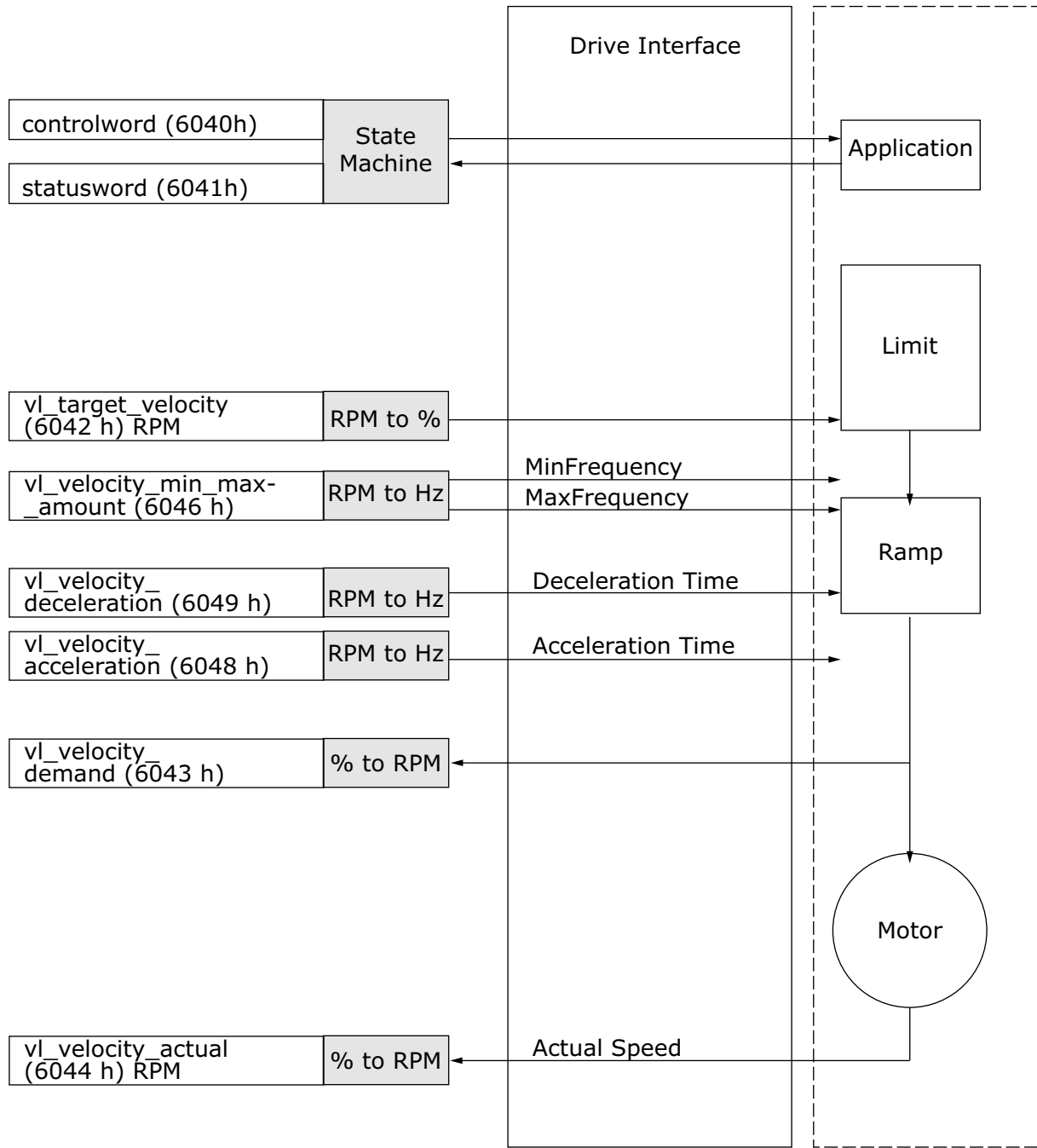

9428_uk



11279.jpg

EtherCAT® is a registered trademark and patented technology, licensed by Beckhoff Automation GmbH, Germany.

VACON[®]

DRIVEN BY DRIVES

Find your nearest Vacon office
on the Internet at:

www.vacon.com



Manual authoring:
documentation@vacon.com

Vacon Plc.
Runsorintie 7
65380 Vaasa
Finland

Subject to change without prior notice
© 2014 Vacon Plc.

Document ID:



Rev. B

Sales code: DOC-OPTEC+DLUK