

X2

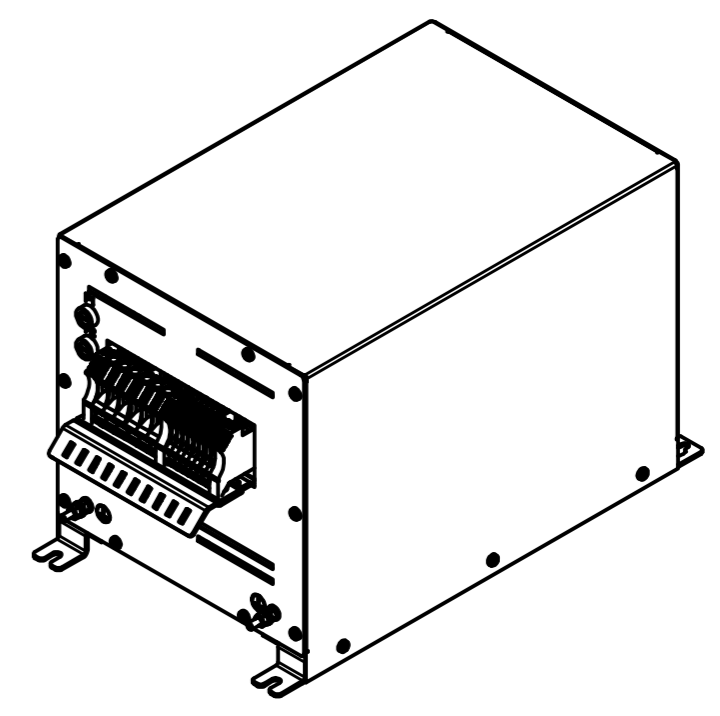
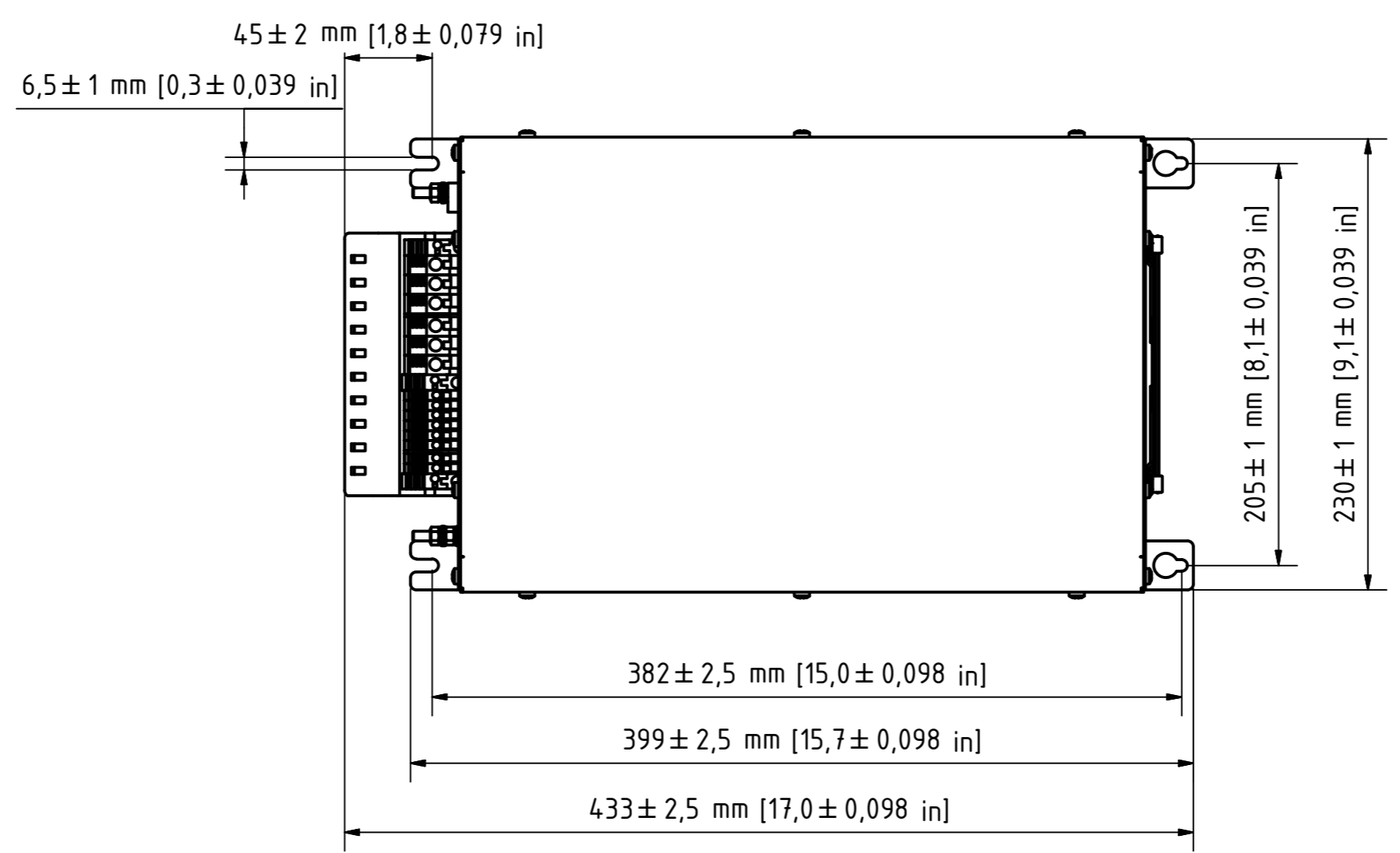
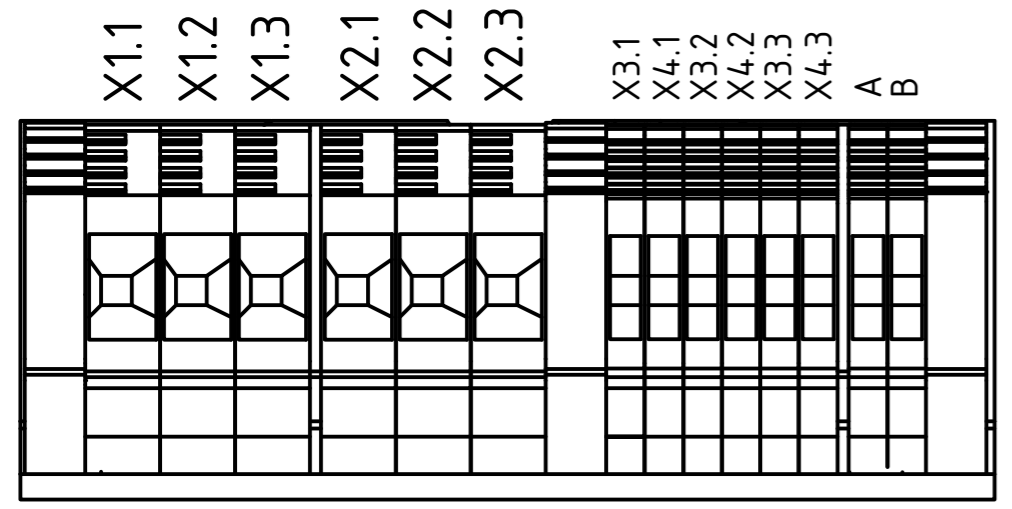
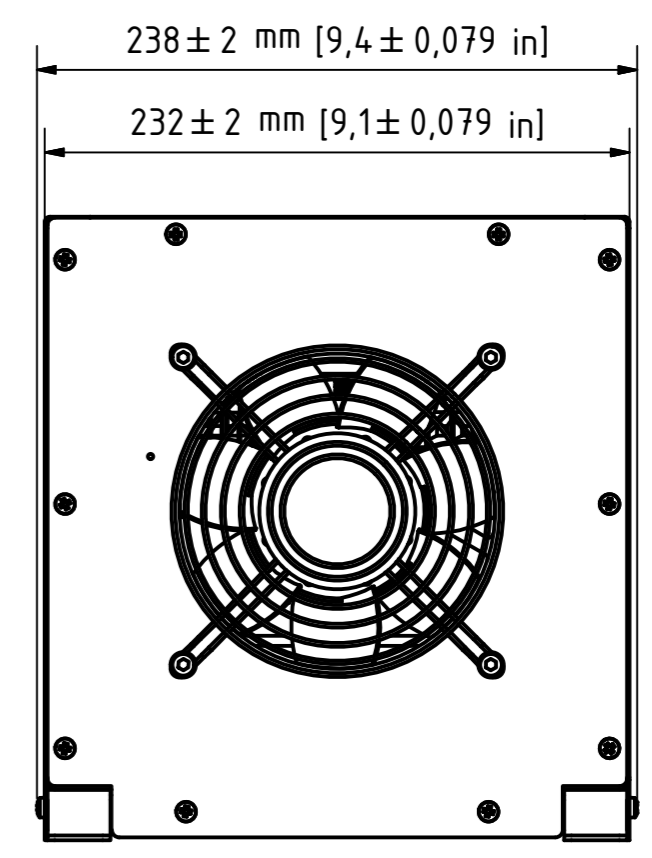
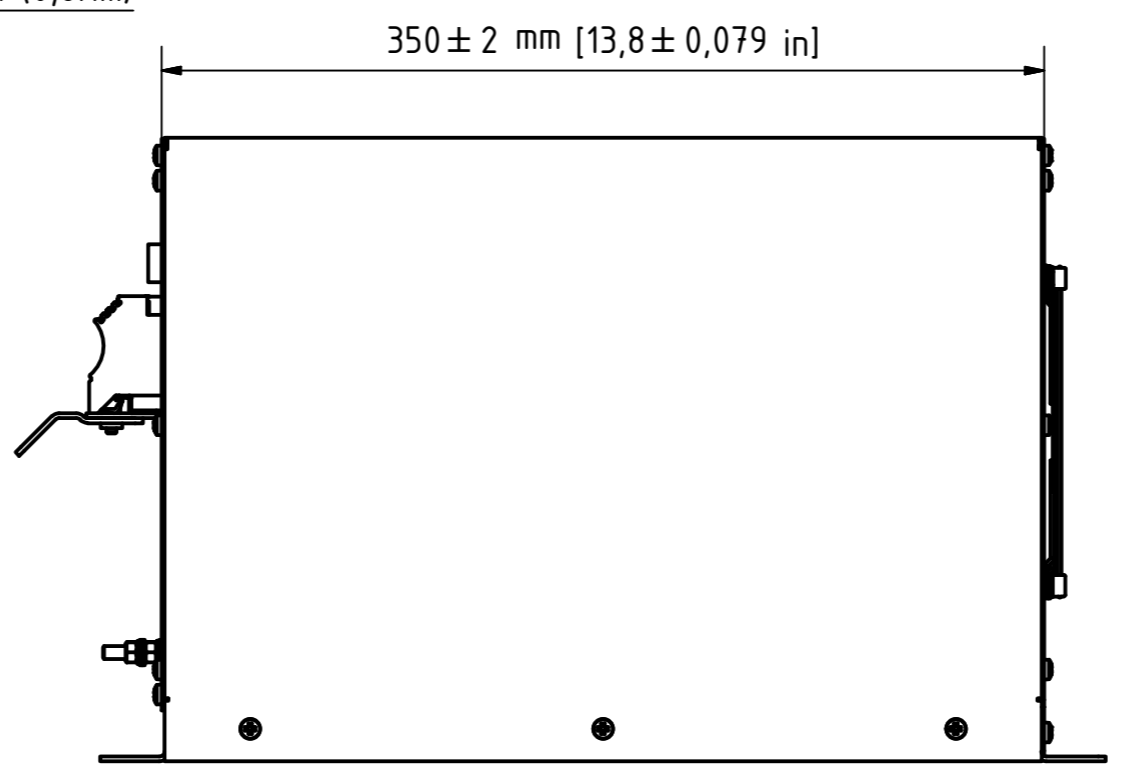
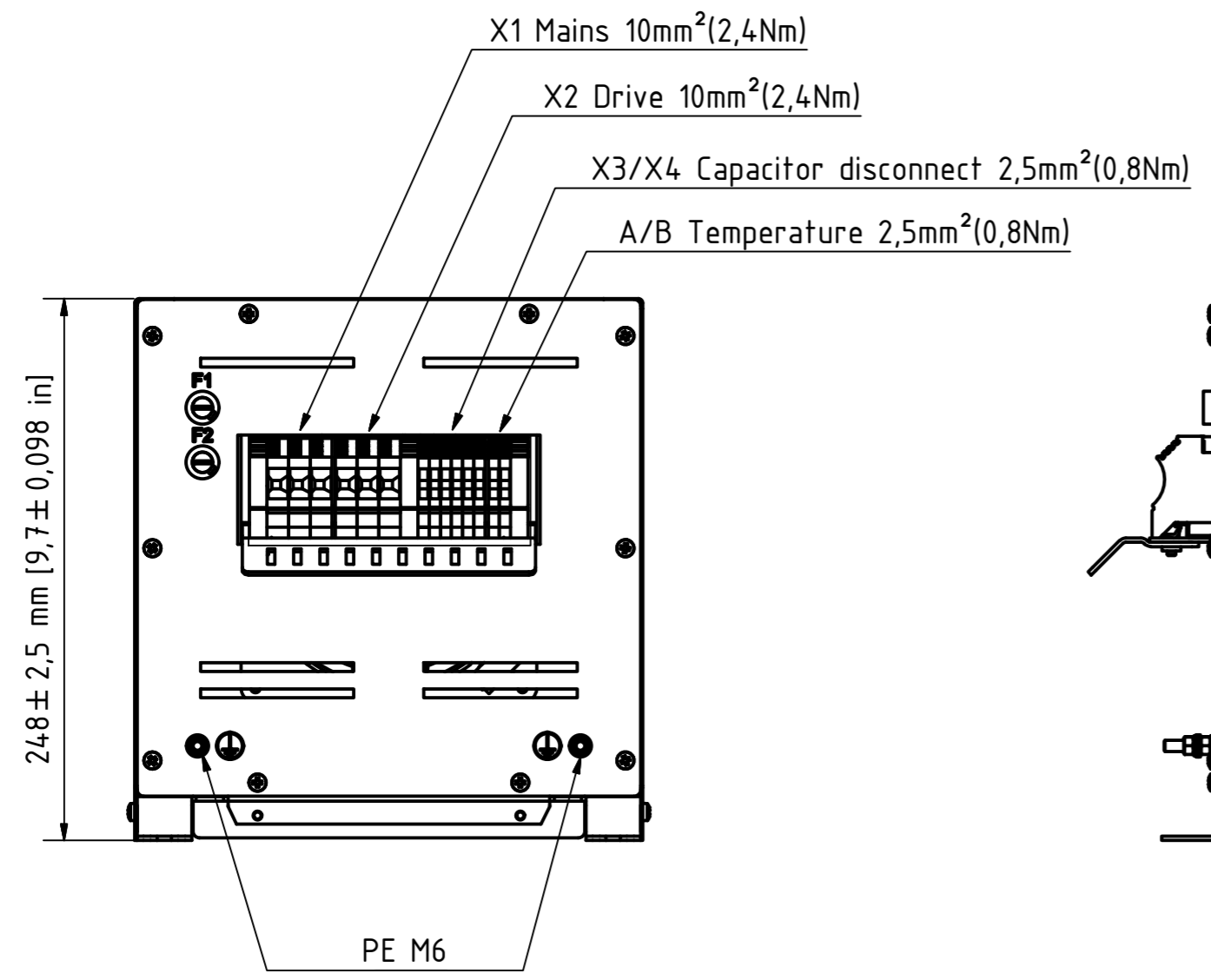

				DATE	Name	Designation	
				Drawn 11.03.2014	CM	X2 IP20 with internal fan 1	
				Reviewed 11.03.2014	FR		
				Standard	DIN 2768-1 V		
				Scale drawing	1:1		
				Print scale	Approx. 1:5	Drawing Number	
R	Terminals	14.03.16	1			X2 IP20 if1	
R	Dimensions	04.07.14	1			1	
Status	Modifications	DATE	Name			A2	
<small>F:\16_P&D\12_Entwicklung\12_3D CAD_Baufreizeichnungen\12_Bestteile\12_Überschwingungfilter\Gehäuse\X2</small>							