

X5

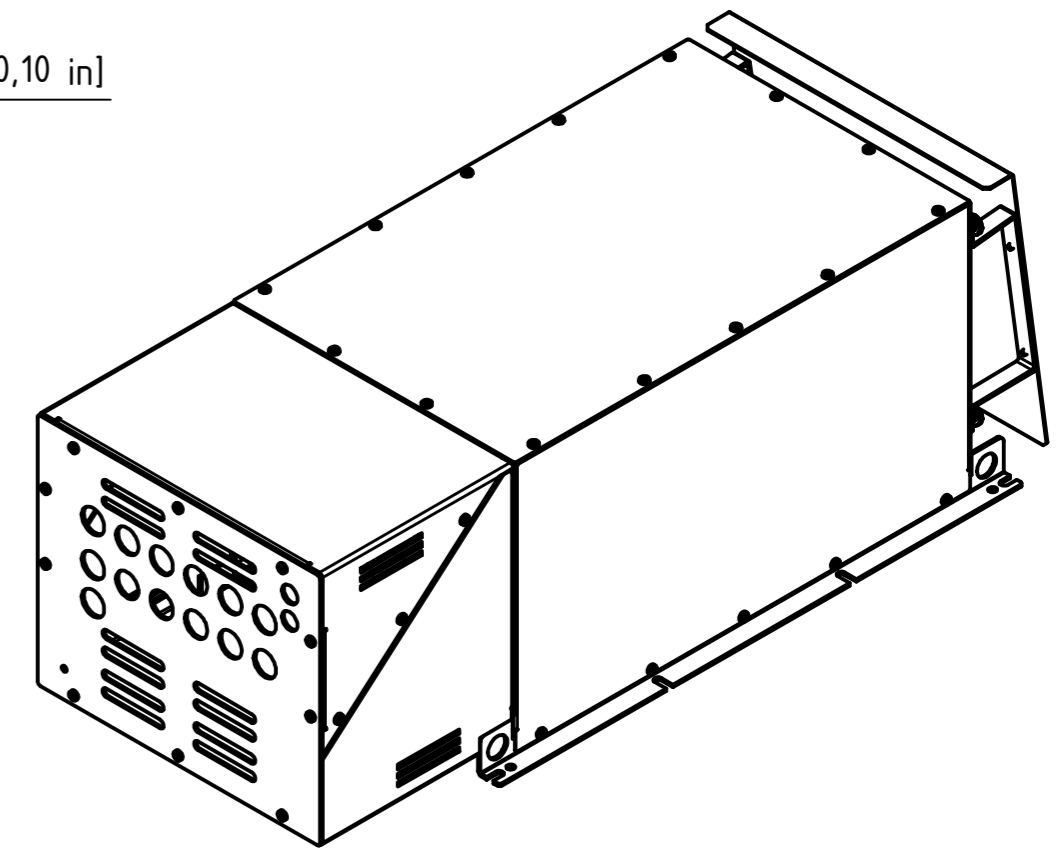
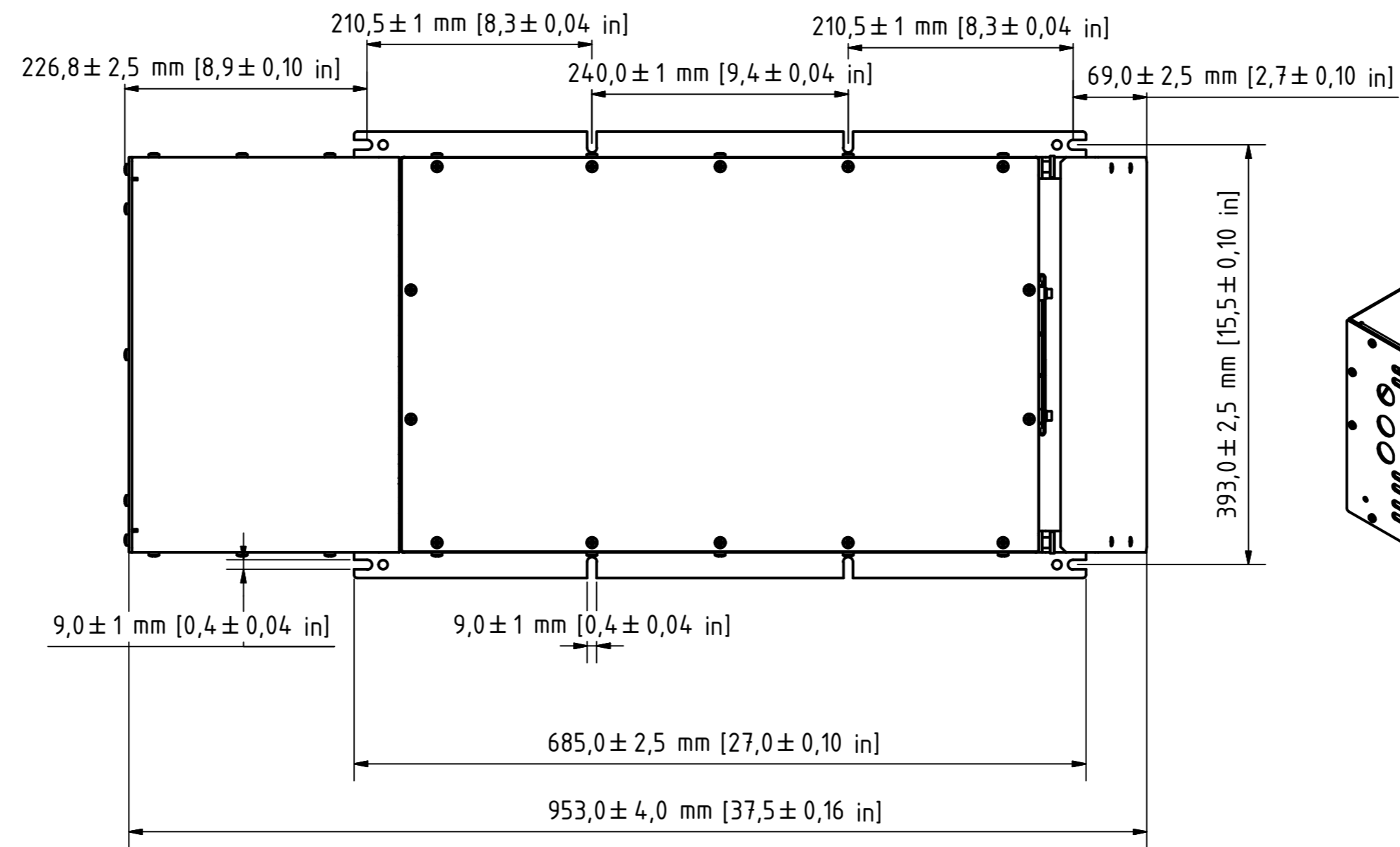
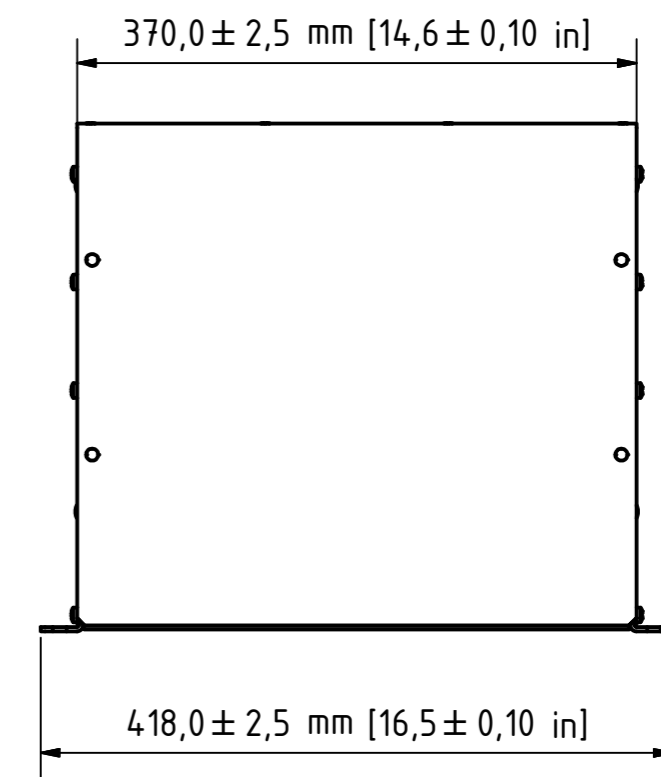
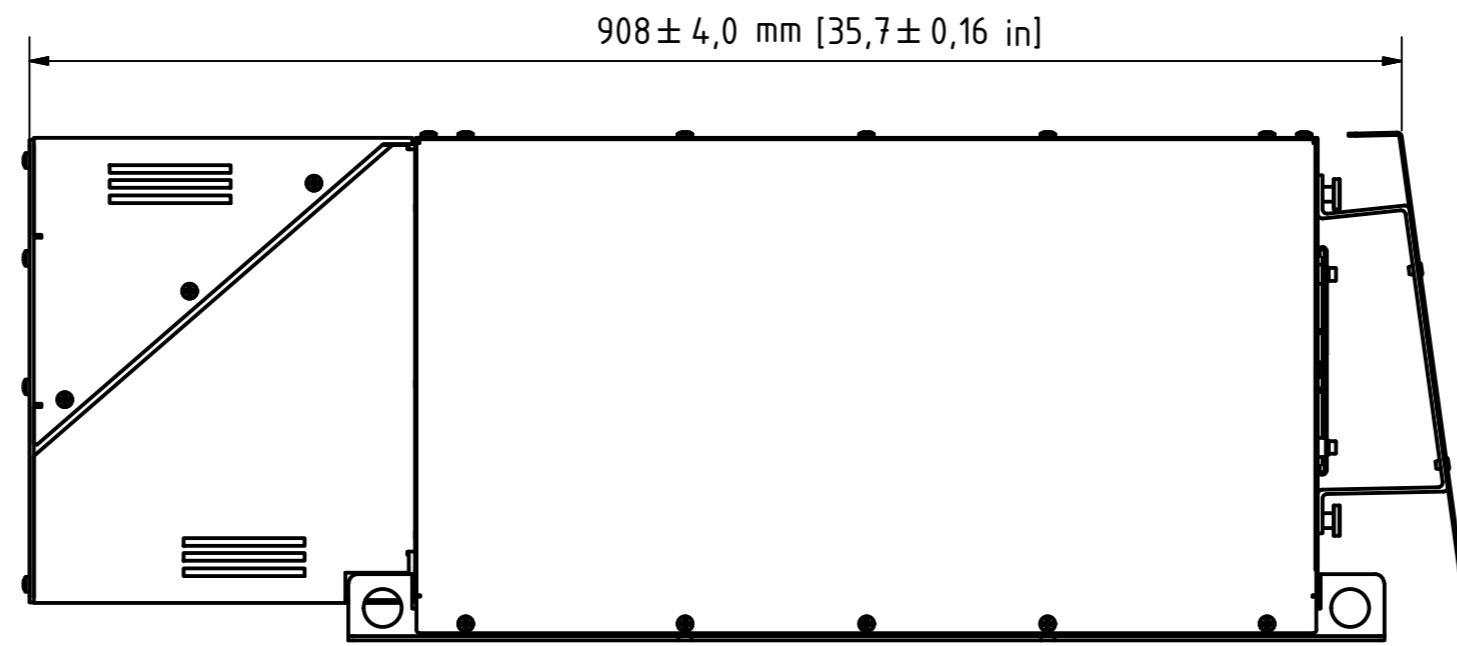
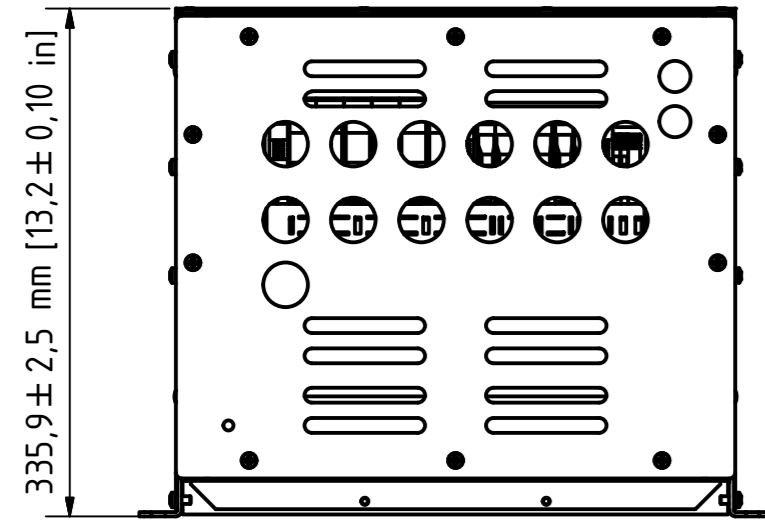

DATE		Name		Designation	
Drawn	04.03.2014	CM	X5 IP21 with internal fan 1		
Reviewed	22.08.2014	MK			
Standard	DIN 2768-1 V				
Scale drawing	1:1				
Print scale	Approx. 1:5				
Drawing Number			1		
X5 C IP21 if1			A2		
Status	Modifications	DATE	Name	P:\14_P&D\12_Entwicklung\13_CAD_Baufreizeichnungen\13_Bestteile\13_Überschwingungsfiler\GehäuseX5	