

4,05,3 ± 2,5 mm [16,0 ± 0,098 in]

X6

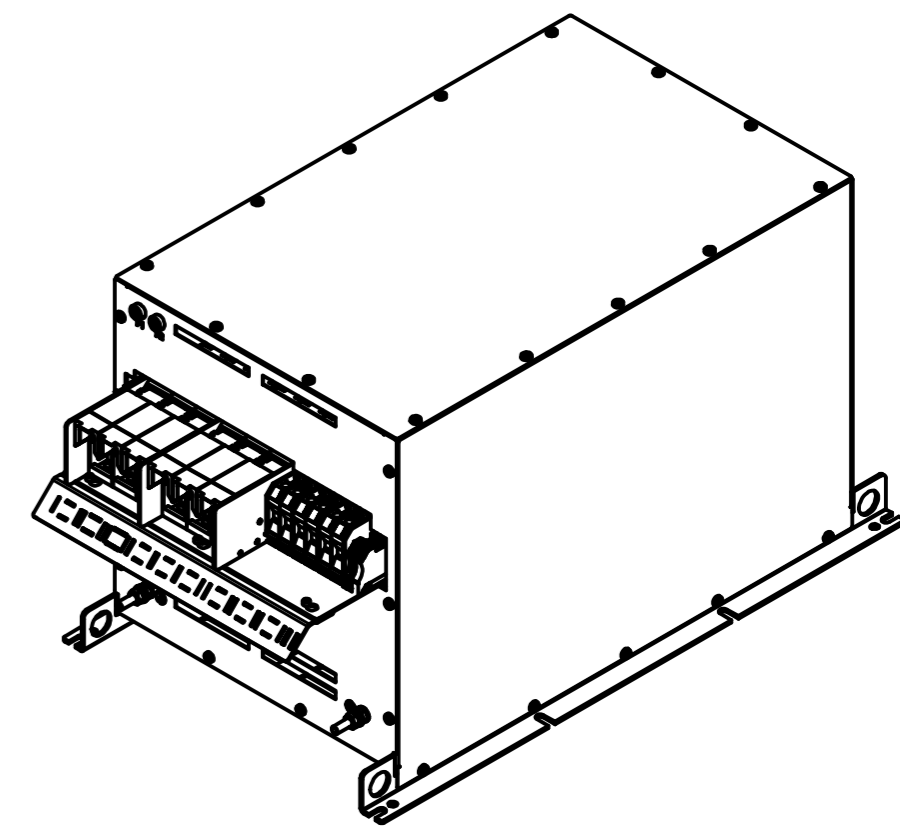
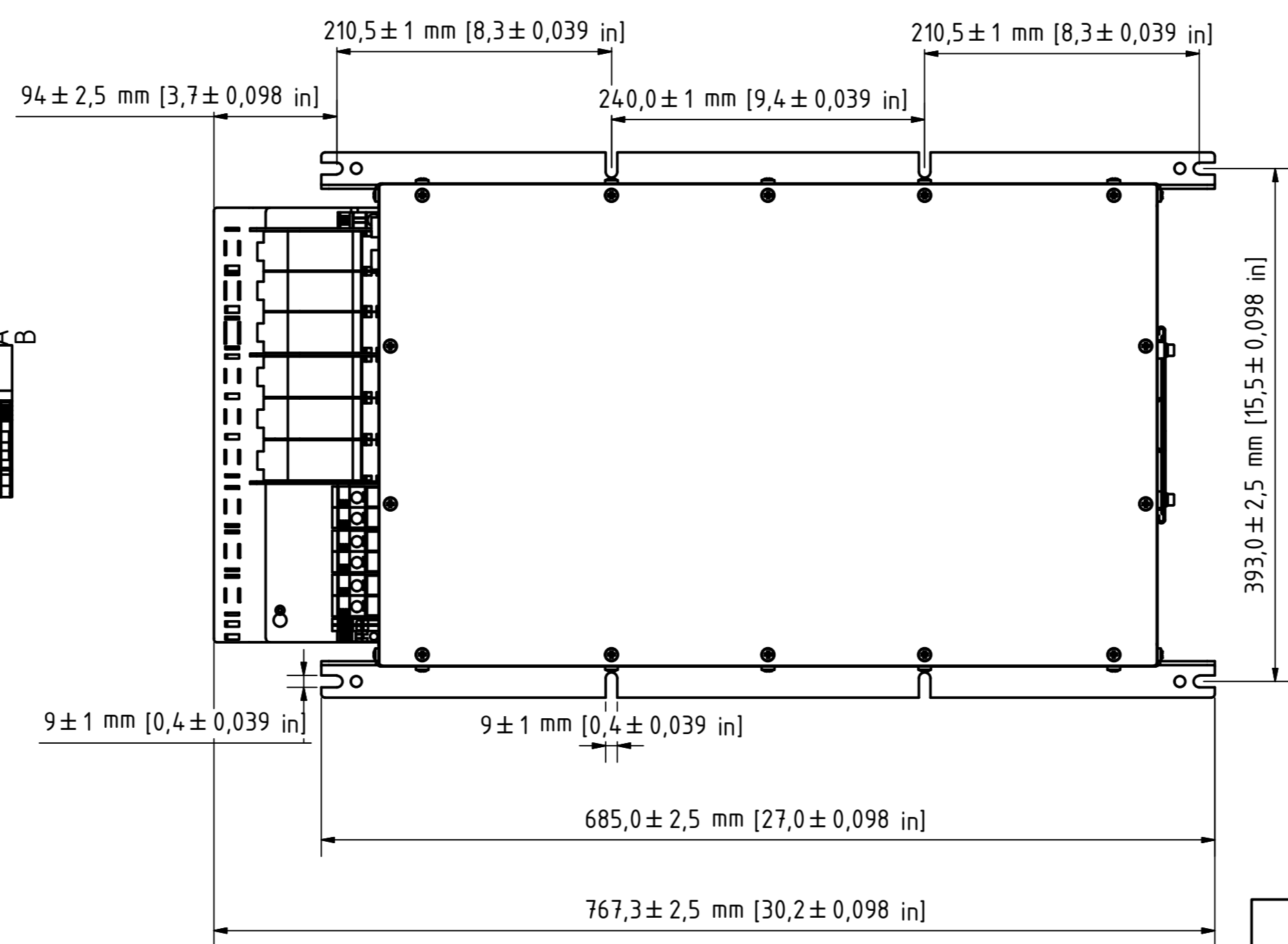
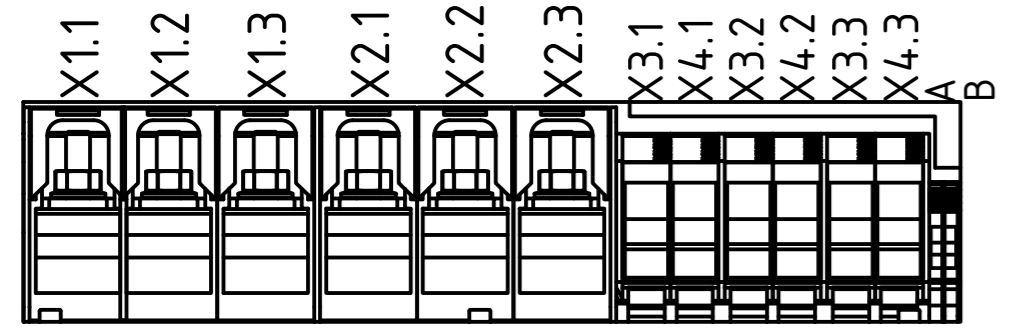
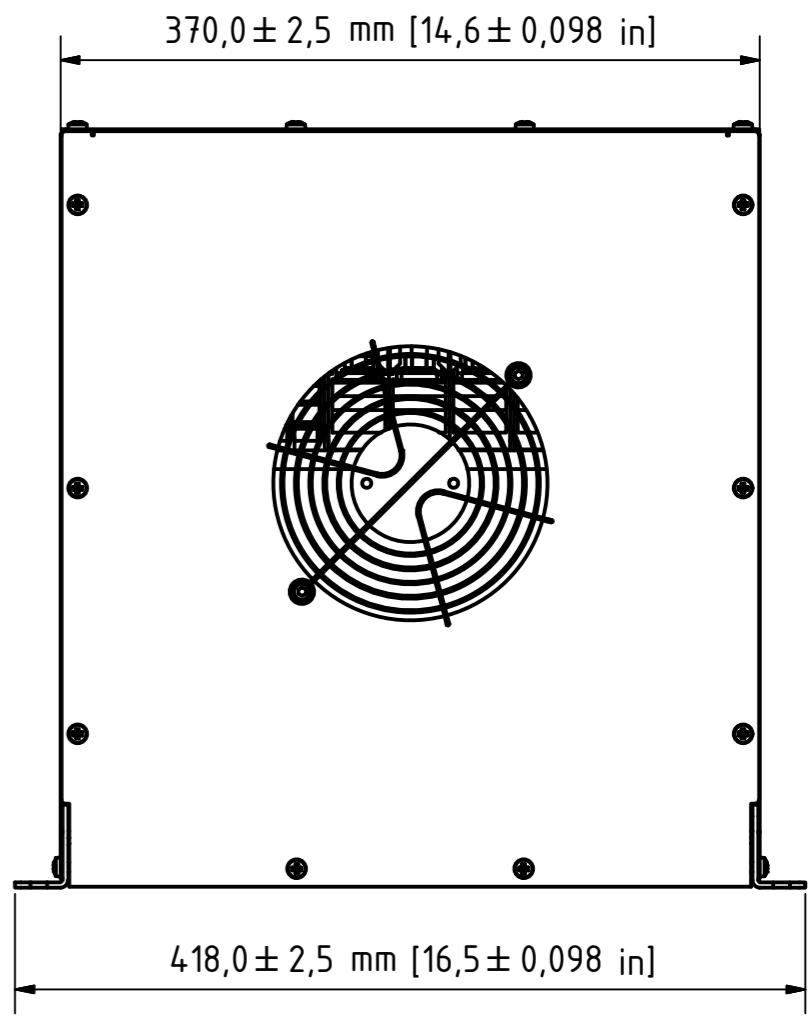
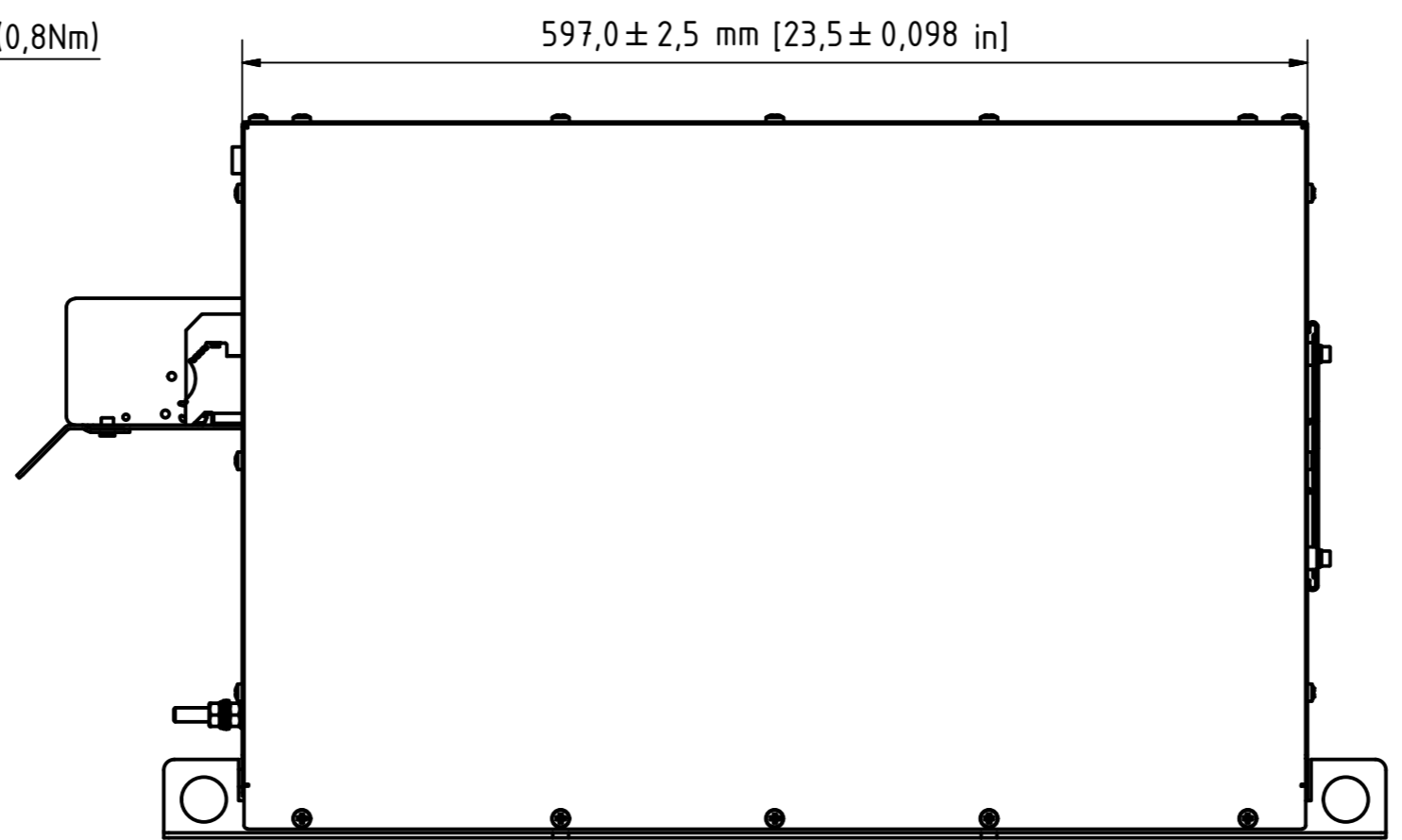

			DATE	Name	Designation		
			Drawn 03.03.2014	CM	X6 IP20 with internal fan 1		
			Reviewed 22.08.2014	MK			
			Standard	DIN 2768-1 V			
			Scale drawing	1:1			
			Print scale	Approx. 1:5	Drawing Number		
R	Terminals	14.03.16	1		X6 C IP20 if1		1
R	Dimensions	04.07.14	1				A2
Status	Modifications	DATE		Name	P:\16_P&D\12_Entwicklung\12_3D CAD_Baufreizezeichnungen\12_Bereitete\12_Überschwingungfilter\GehäuseX6		