

Decentral Motor Starter DMS 300

Operating Instructions



■ Contents

Introduction	3
Operating instructions	3
Symbols used in this manual	3
General warning	3
Safety regulations	3
Warning against unintended start	3
Avoiding DMS damage	3
 Mechanical details	 4
Description	4
General layout	4
Construction	4
Tools required	4
Wall mounting	4
Motor mounting	4
Ventilation	4
 Electrical connections	 6
Power Wiring	6
Power factor correction	6
Control Wiring	6
Motor thermistors	7
Serial communication	7
Earthing	7
High voltage warning	7
Galvanic isolation (PELV)	7
Electrical Schematic	8
 Setting up DMS	 9
Adjustment/ Settings	9
Start/ stop profile setting	9
Start/ stop profile setting table:	9
Trip Class selection :	10
Trip Class selection table :	10
Full Load Current setting:	10
FLC setting table :	11
Completing the installation:	11
 Operation details	 12
Operation	12
Powering-up the DMS	12
Starting the motor :	12
Brake Release	12
Operation with AS-i Interface	12
Description of AS-i profiles used with DMS	12
Fault Procedure	14
Reading the "Alarm" LED	14
Replacing a faulty unit	14

Specification and order codes	15
General Technical Data	15
Current Ratings (AC53a ratings)	15
Ordering type code	16
Certifications	16
Fuses	17
Order code format	18
Special variants:	19
Motor connection	19
Details of Profibus Connectivity	20
Profibus DP Slave 6 E/DC 24 V, 4 A/DC 24 V/1A	20
Table of bits in control and status word	20
Profibus connector PCB 4 x M12	21
Profibus address setting: DIP switch SW3	21

■ Operating instructions

DMS Version no. 02

These operating instructions can be used for all DMS 300 units with version no. 02. The version no. can be identified from the product serial number. The 5th and 6th digit from left pertain to the version no. Thus serial number xxxx-02-xxx indicates version no. 02.

■ Symbols used in this manual

When reading this manual you will come across different symbols that require special attention. The symbols used are the following:



NB!:

Indicates something to be noted by the reader



Indicates a general warning



Indicates a high voltage warning

■ General warning



The DMS contains dangerous voltages when connected to line voltage. Only a competent electrician should carry out the electrical installation. Improper installation of the motor or the DMS may cause equipment failure, serious injury or death. Follow this manual as well as national and local rules and safety regulations.

■ Safety regulations

1. The DMS must be disconnected from the mains if repair work is to be carried out.
2. The [COASTING STOP INVERSE] command applied to the DMS does not disconnect the equipment from the mains and thus is not to be used as a safety switch.



It is the responsibility of the user or the person installing the DMS to provide proper grounding and branch circuit protection in accordance with national and local regulations.

■ Warning against unintended start

1. The motor can be brought to a stop by means of digital commands, bus commands or a local stop, while the DMS is connected to the mains. If personal safety considerations make it necessary to ensure that no unintended start occurs, these stop functions are not sufficient.
2. A motor that has been stopped may start if faults occur in the electronics of the DMS.

■ Avoiding DMS damage

Please read and follow all instructions in this manual.



Electrostatic Precaution; Electrostatic discharge (ESD). Many electronic components are sensitive to static electricity. Voltages so low that they cannot be felt, seen or heard, can reduce the life, affect performance, or completely destroy sensitive electronic components. When performing service, proper ESD equipment should be used to prevent possible damage from occurring.

■ Description

The Danfoss DMS is an advanced electronic motor starting system. It performs six main functions:

1. Start control, including soft start.
2. Stop control, including soft stop (extended stop time).
3. Thermistor motor protection
4. Electronic motor protection (optional).
5. Electromechanical brake control (optional)
6. Monitoring & system interface.

■ General layout

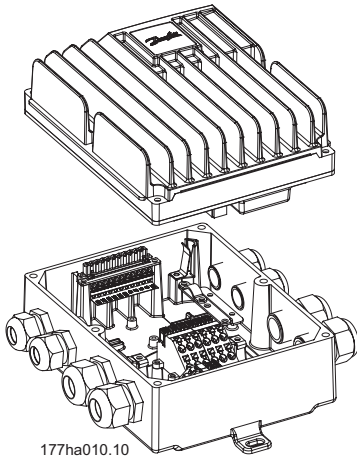

■ Construction

The DMS unit is made of two separable parts:

1. Installation box, which is the bottom half. The installation box has all the mounting arrangement, cable entries, and earthing studs.
2. Electronics Module, which is the top half. The electronics module contains all the circuitry of the DMS.

■ Tools required

The DMS unit does not require any special tools for installation.

All the power & control connections are snap-on, spring-loaded type.

The following set of tools is adequate for installing the DMS units:

- Screw Drivers, general (or T20 Torxslot)
- Spanners – 28 AF and 24 AF
- Centre-punch for motor-mounted versions, if not already mounted on a motor

■ Wall mounting

For best cooling, the DMS unit should be mounted vertically. If needed, horizontal mounting is allowable.

For installing, use the three eye-holes provided. Use the nylon washers provided to avoid scratching the protective paint.

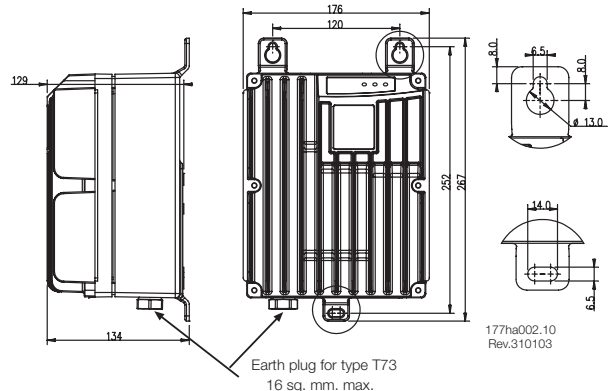

Dimension drawing - DMS Wall mount version

■ Motor mounting

1. Remove the cover of motor terminal box.
2. In the DMS Installation box, knock out 4 screw holes to match the motor terminal box. Two hole-patterns (4 holes each) have been provided to suit Danfoss Bauer geared motors, depending on the power size of the motor. For different motors use the outer holes and the adaption plate [Order no. 175N2115]
3. In the DMS Installation box, knockout the motor cable gland (1 of 30 mm diameter) for the power connection to motor terminals.
4. Mount the DMS Installation Box direct on the motor terminal box.

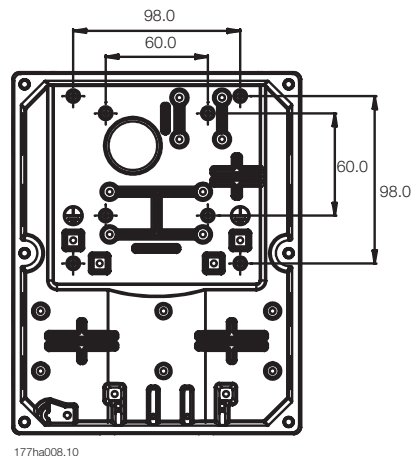

177ha008.10

Dimension drawing - DMS Motor mount version



NB!:

Do not mount in direct sunlight or near heat radiating elements.

■ Ventilation

DMS cooling is by means of air circulation. Consequently, the air needs to be able to move freely above and below the soft starter. If installing the DMS in a switchboard or other enclosure, ensure there is sufficient airflow through the enclosure to limit heat rise in the enclosure to maintain the internal enclosure temperature at or below 40 deg. C. (Heat loss of DMS at rated current is 18 watts approx.).

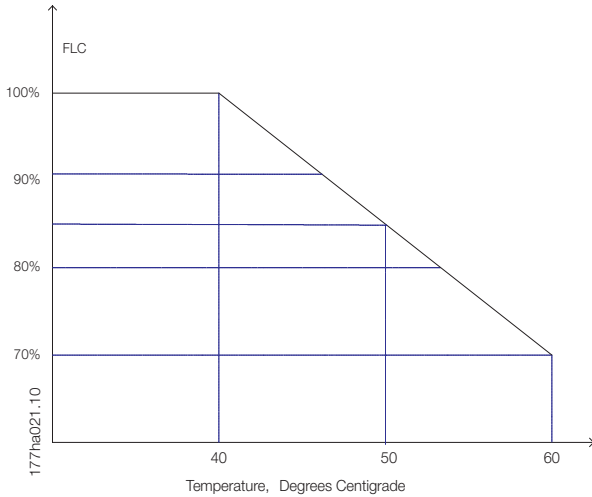

Derating curve for temperature

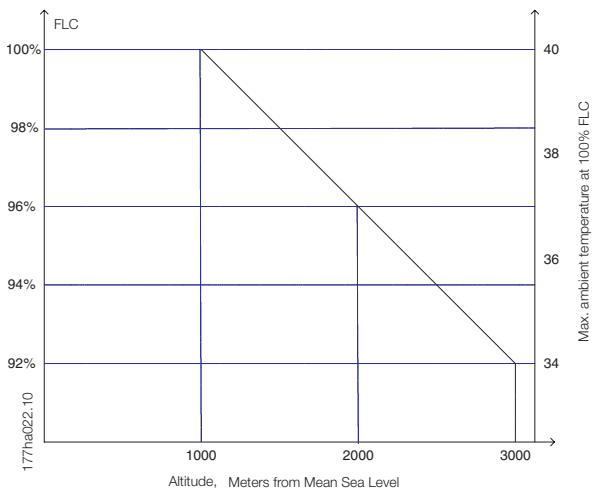

Derating curve for altitude

Mechanical details

■ Power Wiring

Connect the Supply voltage to the DMS input terminals 1/L1, 3/L2 & 5/L3. The terminals in the Extended versions of the DMS allow two cables to loop the power line as shown.

Use of screw driver to open the connector clamp

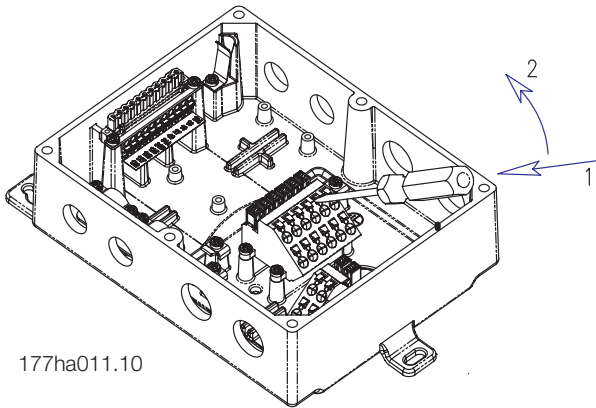

177ha011.10

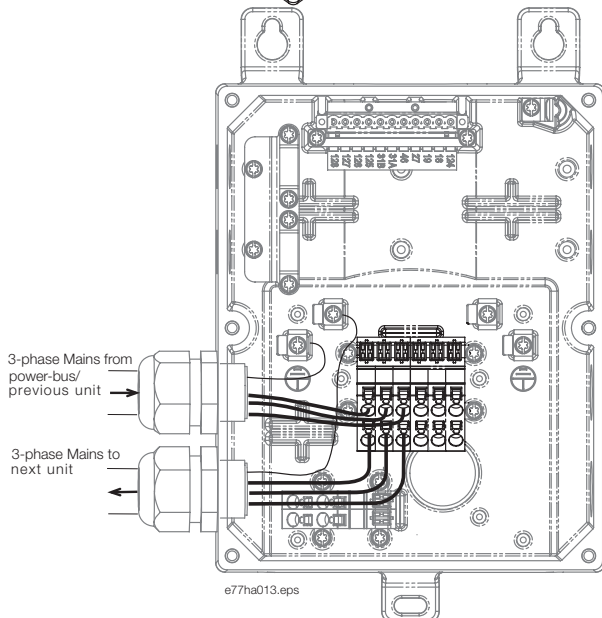

Looping the power line - 3-phase mains

Connect the Motor terminals to the DMS output terminals 2/T1, 4/T2 & 6/T3. Take care of the phase sequence to have the correct direction of rotation. The terminals in the Extended versions of the DMS allow two cables to connect two motors in parallel to one DMS.

Maximum cross section: 4 mm sq. (10 AWG)

For ST & SB versions, provide strain relief for power and control cables by using the cable support provided in the DMS unit, as shown.

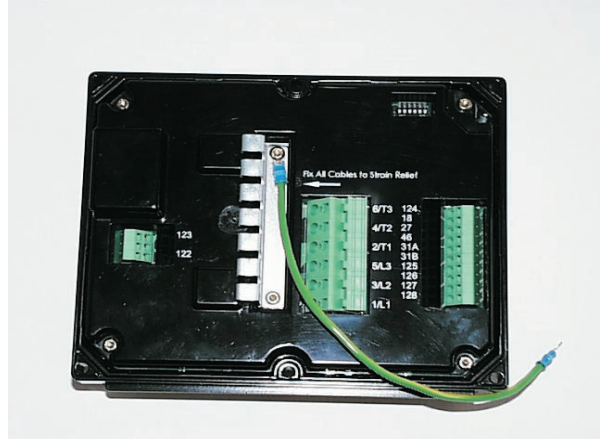

■ Power factor correction



If a DMS is used with static power factor correction it must be connected to the supply side of the DMS.

Connecting power factor correction capacitors to the output of the DMS will result in damage to the DMS.

■ Control Wiring

Complete the Control wiring as shown in the Electrical Schematic diagram.

Use of a screw driver to open the connector clamp for control terminals [Press to open the clamp]

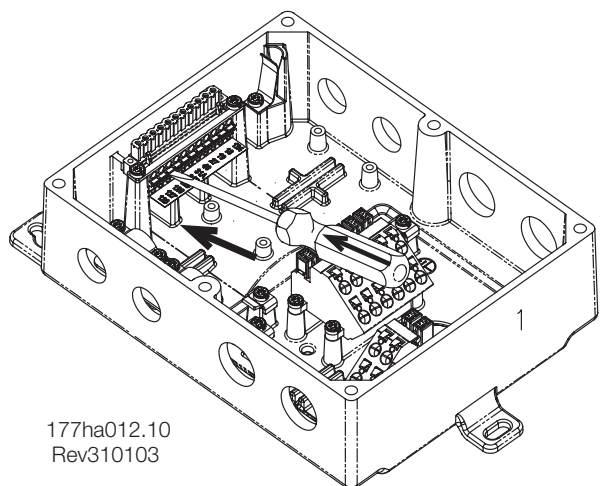

Connect Control Supply / AS-i Interface at the terminals provided.

Contacts used for controlling these inputs should be low voltage, low current rated (Gold flash or similar)
Maximum cross section: 2.5 mm² (12 AWG)

Use cables complying with local regulations.

■ Motor thermistors

If the motor is fitted with thermistors these may be connected directly to the DMS. To connect the thermistors, first remove the shorting link, and then connect the thermistors between terminals 31A & 31B.



Use double-isolated thermistors to retain PELV.

■ Galvanic isolation (PELV)



All control terminals, and terminals for serial communication are safely isolated from the mains potential, i.e. they comply with the PELV requirements of EN/ IEC 60947-1. PELV isolation of the control card is guaranteed provided there is max. 300 VAC between phase and earth.

■ Serial communication

The DMS can be equipped with either AS-i or Profibus communication capabilities. The AS-i and Profibus interfaces are optional. The AS-i Fieldbus is connected at terminals 125 & 126. The details of the Profibus connectivity are given at the end of the manual.



NB!:

Communications and control cabling should not be located within 300mm of power cabling. Where this cannot be avoided consideration should be given to providing magnetic shielding to reduce induced common mode voltages, for example, by laying the communication and control cables in a separate conduit.

■ Earthing



Ensure that the DMS unit is earthed properly. Use the chassis earth studs provided for the purpose (4 of size M4). For type T73 units, an external earth plug (size M8) is provided to facilitate earthing.



To retain the IP rating of DMS, remember to close all the unutilized cable entries using the gland plugs (bungs) provided loose with the DMS unit. In units with external plugs, all plugs must be correctly mounted.

■ High voltage warning



The voltage of the DMS is dangerous whenever the equipment is connected to the mains. Ensure the DMS is correctly connected and that all safety measures have been taken before switching on the supply.

■ Electrical Schematic

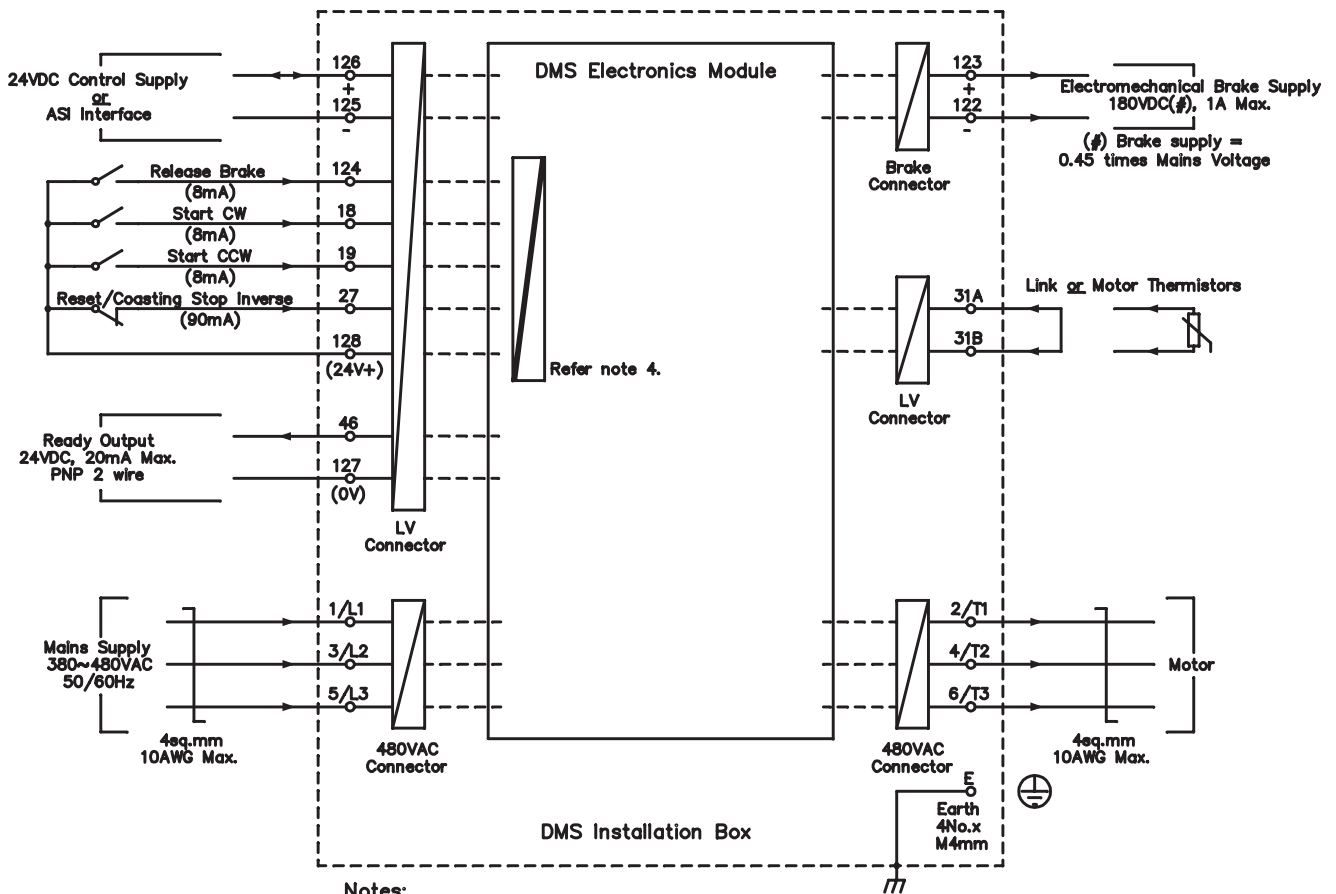

Notes:

1. All external wiring to be 2.5sq.mm (12AWG) maximum unless otherwise detailed.
2. For Standard DMS (versions SB/ST) all the connectors are located on the Electronics Module. For Extended DMS (versions EX/EB/ER) all the connectors are located on the Installation Box.
3. The Terminals in the Extended versions of the DMS allow two cables for looping the power line.
4. The control inputs are galvanically isolated.

177HA004.10
Rev.27.11.02

■ Adjustment/ Settings

DMS adjustments are made using the DIP switch adjustment panel located on the underside of the Electronics module.

	Section	Switch no.	Description	Value	Factory setting		
	A	1	Start/ stop profile setting	Selection of ramp times and start voltage. See table below.	Off	Profile no.0	
		2			Off		
		3			Off		
		4			Off		
		5	Trip class selection	See table below	Off	Trip class 5	
		6		Off			
	B	1	Not used				
		2	Full load current setting (note: 0.1Amps is always added internally)	3.2A	Off	FLC = 0.1A	
		3		1.6A	Off		
		4		0.8A	Off		
		5		0.4A	Off		
		6		0.2A	Off		
		See table below					

Note: Settings marked grey are applicable only in Extended versions.

■ Start/ stop profile setting

Choose the required Start/ Stop profile which is most suited to the application. Use DIP switches A1-A4 to set the start/stop profile. Some examples are shown below.

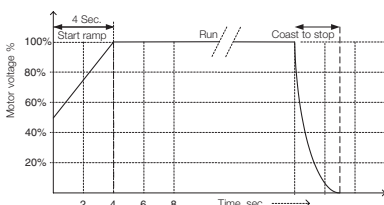
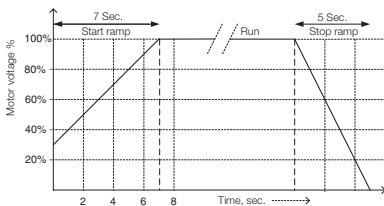

■ **Start/ stop profile setting table:**

Start/stop Profile	Start Performance	Stop Performance	1 (A1)	2 (A2)	3 (A3)	4 (A4)	Initial Voltage (%)	Start Ramp Time (sec) #	Stop Ramp time (sec) #
0	Equivalent to DOL	Coast to stop	Off	Off	Off	Off	80	0.25	*
1	Fastest Slowest	Coast to stop	Off	Off	Off	On	80	0.5	*
2			Off	Off	On	Off	60	0.75	*
3			Off	Off	On	On	60	1.5	*
4			Off	On	Off	Off	60	1.0	*
5			Off	On	Off	On	50	2	*
6			Off	On	On	Off	40	3	*
7			Off	On	On	On	50	4	*
8			On	Off	Off	Off	60	6	*
9			On	Off	Off	On	60	8	*
10	Fastest Slowest	Fastest	On	Off	On	Off	60	2	1
11			On	Off	On	On	50	3	2
12			On	On	Off	Off	40	4	3
13			On	On	Off	On	40	5	3
14			On	On	On	Off	30	7	5
15		Slowest	Slowest	On	On	On	On	30	9

Note: * indicates Stop Ramp time is not controlled by DMS. Motor will coast to stop.

In some applications, actual ramp time on the motor shaft could differ from the settings.

■ **Trip Class selection :**

This setting is applicable only for the Extended versions of DMS. The DMS motor overload protection is an advanced motor thermal model. Motor temperature is continuously calculated by the microprocessor. This uses a sophisticated mathematical model to accurately reflect motor heat generation and dissipation during all stages of operation, e.g. Starting, Running, Stopping & Stopped. Because it operates continuously, the motor thermal model eliminates the need for protection systems such as Excess Start Time, Limited Starts per hour etc. Calibrate the DMS motor thermal model for the Trip Class of the connected motor. The Motor Trip Class is defined as the length of time the motor can sustain Locked Rotor Current. The motor Trip Class can be found from the motor curves or data sheet. For example, if a given motor can

withstand Locked Rotor Current for 10 sec, set Trip Class 10 (or lower) in the DMS. If in doubt, use "Trip Class 5", which is the Factory Default setting for this parameter. With this setting, the DMS will trip & protect the motor if the Locked Rotor current sustains for more than 5 secs. Use the DIP switches A5-A6 to choose the Trip Class.

■ **Trip Class selection table :**

Trip Class Time (sec)	5 (A5)	6 (A6)	Remarks
5	Off	Off	Trip Class 5
10	Off	On	Trip Class 10
20	On	Off	Trip Class 20
0	On	On	Motor Protection off

■ Full Load Current setting:

This setting is applicable only for the Extended versions of DMS and refers to the ETR function. It may not be used for current limitation.

Calibrate the DMS for the connected motor nameplate Full Load Current (FLC).

Use the five (5) DIP switches B2-B6 to add up to motor nameplate FLC minus 0.1 Amps. (0.1 Amps is added internally to the FLC amps. read from the DIP switches) Please note that switch B1 is not used.

■ FLC setting table :

DIP Switch bits	Value (Amps)	Example-1 for setting FLC=4.3 Amps	Example-2 for setting FLC=2.9 Amps
2 (B2)	3.2	On	Off
3 (B3)	1.6	Off	On
4 (B4)	0.8	On	On
5 (B5)	0.4	Off	On
6 (B6)	0.2	On	Off
	6.3 Amps, when B2-B6 are all On	0.1 +3.2+0+0.8+0+0.2 = 4.3 See remark	0.1 +0+1.6+0.8+0.4+0 =2.9 See remark

Note:**0.1 Amps** is added internally to the value read from DIP switches.

■ Completing the installation:

To complete installation, fit the DMS Electronics module to the DMS Installation box and secure with the screws provided. Recommended tightening torque for the screws is between 2.5 and 3 Nm.

■ Operation

Once the DMS has been installed, wired and programmed according to the instructions, it can be operated.

■ Powering-up the DMS

Power may now be applied to the DMS unit. The "On" LED should glow when the 24VDC Control Supply is turned On.

■ Starting the motor :

Connect +24VDC to the "Reset/ Coasting stop inverse input (27).

To start the motor in the Forward direction, use the Start CW Input (18). To initiate a stop, open the Start CW Input.

To start the motor in the Reverse direction, use the Start CCW Input (19). This feature is optional. To initiate a stop, open the Start CCW Input.

If the direction of rotation is wrong, change any two of mains **or** motor phases.

Disconnecting the +24VDC to the "Reset/ Coasting stop inverse input (27) will disable the DMS and cause the motor to coast to stop.

**NB!:**

If both Start CW & Start CCW inputs are active together, the motor will stop.

■ Brake Release

(For variants with Braking function only - variants SB, EB, ER).

When a Start is initiated, the DMS automatically generates a brake release command. This will release the brakes before the motor starts running.

The motor brake can also be released without starting the motor by connecting +24VDC to the Brake Release input (124).

**NB!:**

Mains supply to the DMS is required for the operation of Brake Release. The Electromechanical brake supply is **not** short-circuit protected.

■ Operation with AS-i Interface

The AS-i switch profile S-7.E is used, having the following inputs and outputs:

- Start CW (D0)
- Start CCW (D1)
- Brake Control (D2)
- Reset (D3)
- Ready output(D0)
- Run Output (D1)
- Fault Output (D2)

The profile codes with the different variants are:

- Profile 7E 1 for Extended
 - Profile 7E 3 for Extended with Brake
 - Profile 7E 4 for Extended with Brake & Reversing
-

■ Description of AS-i profiles used with DMS

Bit	Type for host	Meaning	Host level	Direct starter Profile 7E 1	Direct starter with brake Profile 7E 3	Reverser with brake Profile 7E 4
D0	output	Run forward	0 1	Stop - forward Start - forward	Stop - forward Start - forward	Stop - forward Start - forward
D1	output	Run reverse	0 1	Not used	Not used	Stop - reverse Start - reverse
D2	output	Brake	0 1	Not used	Motor blocked Motor free	Motor blocked Motor free
D3	output	Fault reset	0 1	Not reset Reset	Not reset Reset	Not reset Reset
D0	input	Ready	0 1	Not ready or fault Ready	Not ready or fault Ready	Not ready or fault Ready
D1	input	Running	0 1	Motor stopped Motor running	Motor stopped Motor running	Motor stopped Motor running
D2	input	Fault	0 1	No fault Fault	No fault Fault	No fault Fault
D3	input	Not used	0 1	Not used	Not used	Not used
P0	parameter	Not used				
P1	parameter	Not used				
P2	parameter	Not used				
P3	parameter	Not used				

It is possible to operate DMS with both the control inputs and an AS-i Interface. It will function as follows:

- Start CW: Logically "OR"ed – DMS will Start if either input is active.
- Start CCW: Logically "OR"ed – DMS will Start if either input is active.
- Brake: Logically "OR"ed – DMS will generate Brake release command if either input is active.
- Reset/Coasting stop inverse: Logically "AND"ed.



NB!:

Both inputs must be active for DMS to Start. If AS-i bus is used for control, the binary Reset/Coasting stop inverse input must be held active (i.e. connected to +24 VDC)

Configuring DMS with a Slave address:

Use a standard AS-i addressing device or the AS-i master to configure the DMS with the designated slave address on the AS-i network.

■ Fault Procedure

Use the Reset (Reset/ Coasting stop inverse) input to reset any fault.

The "On" LED (Green), when illuminated, indicates that the Control supply is on.

The "Bus" LED (Green), when illuminated, indicates that AS-i bus communication is OK.

The "Alarm" LED (Red), when illuminated, indicates that the DMS is in the alarm/ trip state.

The number of Alarm LED flashes indicates the fault/ trip condition. The Alarm LED will flash a certain number of times, depending on the nature of fault.

■ Reading the "Alarm" LED

No. of flashes	Trip Condition	Cause & Action
One (1)	Power Loss or Shorted SCR	Check supply voltages. This is a pre-start check.
Two (2)	Thermal Overload	Check FLC setting. Check the Motor Trip class setting. Remove the cause of the overload and let the motor cool before restarting.
Three (3)	Motor Thermistor Trip	Identify and correct the cause of motor overheating. If no thermistors are connected to the DMS, ensure there is a closed circuit across the motor thermistor input (terminals 31A & 31B).
Four (4)	Phase Loss	Check supply for missing phase. This is active anytime during start.
Five (5)	Welded Direction Change Relay	Replace unit.

■ Replacing a faulty unit

When replacing the unit:

1. Replace the Electronics Module (top portion) of DMS unit.
2. Retain the Installation box (bottom portion) in its position.



The voltage of the DMS is dangerous whenever the equipment is connected to the mains. Work on the equipment should be carried out by qualified personnel. Before performing any maintenance and repair work, switch off the electrical supply to the device and observe all safety regulations.

■ **General Technical Data**

Supply (L1, L2, L3, 125, 126, 127, 128):

Mains Supply voltage 3 x 380 VAC ~ 480 VAC +/- 10%
 Mains Supply frequency 45HZ ~ 65 Hz
 Electronics control voltage +24VDC (20V to 30V), 150mA nominal

Control Inputs

Start (Terminals 18 & 19) Binary, 24 VDC, 8mA approx.
 Reset/ Coasting stop inverse(Terminal 27) Binary, 24 VDC, 90mA approx. #
 Release Electromechanical Brake (Terminal 124) Binary, 24 VDC, 8mA approx.

*The Control inputs are suitable for connection to a device with a PNP output stage.
 # 20 mA approx. for Standard versions (SB & ST)*

Outputs

Run Output (Terminal 46) Binary, PNP output, 24 VDC, 20mA max.
The output is short circuit protected.

Electromechanical Brake Supply output

Electromechanical Brake Supply Output (Terminals 122 & 123) 180 VDC, 1.0 A max. *

** The electromechanicalbrake supply output voltage is proportional to the mains supply voltage, which is 180 VDC for 400VAC mains, 205 VDC for 460 VAC mains.*

The output is not short circuit protected.

Operating temperature -10 to +60 deg. C (above 40 deg. with derating)
 Relative humidity 5 -90% RH, non-condensing
 Weight 3.5 kg

■ **Current Ratings (AC53a ratings)**

These ratings assume Starting current of 500%
 FLC. All ratings are in Amps.

Continuous Ratings (Not bypassed) at 40 deg. C Ambient Temperature, < 1000 metres				
No. of starts per hour	Start Time (sec.)	Duty Cycle		
		70%	50%	30%
10	5	8.4	8.7	9.0
50	5	7.9	8.1	8.3
100	5	7.3	7.5	7.6
300	1	7.7	8.0	8.2

For ambient temperature or altitude conditions beyond those listed contact Danfoss.

■ Ordering type code

The DMS is available in the following variants:

- Standard
- Standard with Brake
- Extended
- Extended with Brake
- Extended with Brake & Reversing

The Extended variants are available with integrated Fieldbus AS-i interface. The extended versions can be delivered with Profibus interface including 4 additional M12 plugs for connection of external sensors.

Refer to the table for the Part numbers corresponding to the variants.

For example, the part number for a Motor Mount DMS unit, with Reversing function, and without Fieldbus connection would be:
DMS330PT4P66ERD0F00T12C0

■ Certifications

The DMS 300 has CE, UL, cUL and C-tick certifications. The details are as under:

CE

Rated insulation voltage	500 VAC
Rated impulse withstand	2.0 kV (1.2/ 50 micro second)
Conducted and radiated frequency emissions	Class B as per EN 55011
Electrostatic discharge, 4 kV contact and 8 kV air discharge	no effect on operation
Radio frequency electromagnetic field, 0.15 MHz to 1.0 GHz	no effect on operation
Fast transients, 2.0 kV/ 5.0 kHz	no effect on operation
Surges, 2.0 kV line to earth, 1.0 kV line to line	no effect on operation
Voltage dips and short interruptions	no effect on operation
Short circuit tested on 5 kA supply, when protected by semiconductor fuses (Type 2 co-ordination)	no damage to DMS 300, no danger to persons or installation
Short circuit tested on 5 kA supply, when protected by HRC fuses (Type 1 co-ordination)	no danger to persons or installation, DMS unit may be unsuitable for future use

UL**C-tick****IP66**

To maintain certifications, the product shall not be modified in any way, shall be used only for the specified purpose, and must be installed according to this manual and/or any other authorized Danfoss instruction.

■ Fuses

The DMS 300 should be used with suitable fusing as per the co-ordination requirements of the circuit.

Max pre-fuses: DMS 300 meets Type 1 co-ordination with properly rated HRC fuses.

Use type gG 25A, 415 VAC or equivalent HRC fuses.

Semiconductor fuses are required to meet UL, C-UL Certification .

Semiconductor fuses listed below are manufactured by Bussmann and should be ordered directly from Bussmann or their local supplier.

Bussmann, High Speed fuse, Square body, Size 000, 660 V, 20 Amps rated - Part no: 170 M 1310

or

Bussmann, British style, BS88, Type CT, 690 V, 20 Amps rated - Part no: 20CT

Order code format

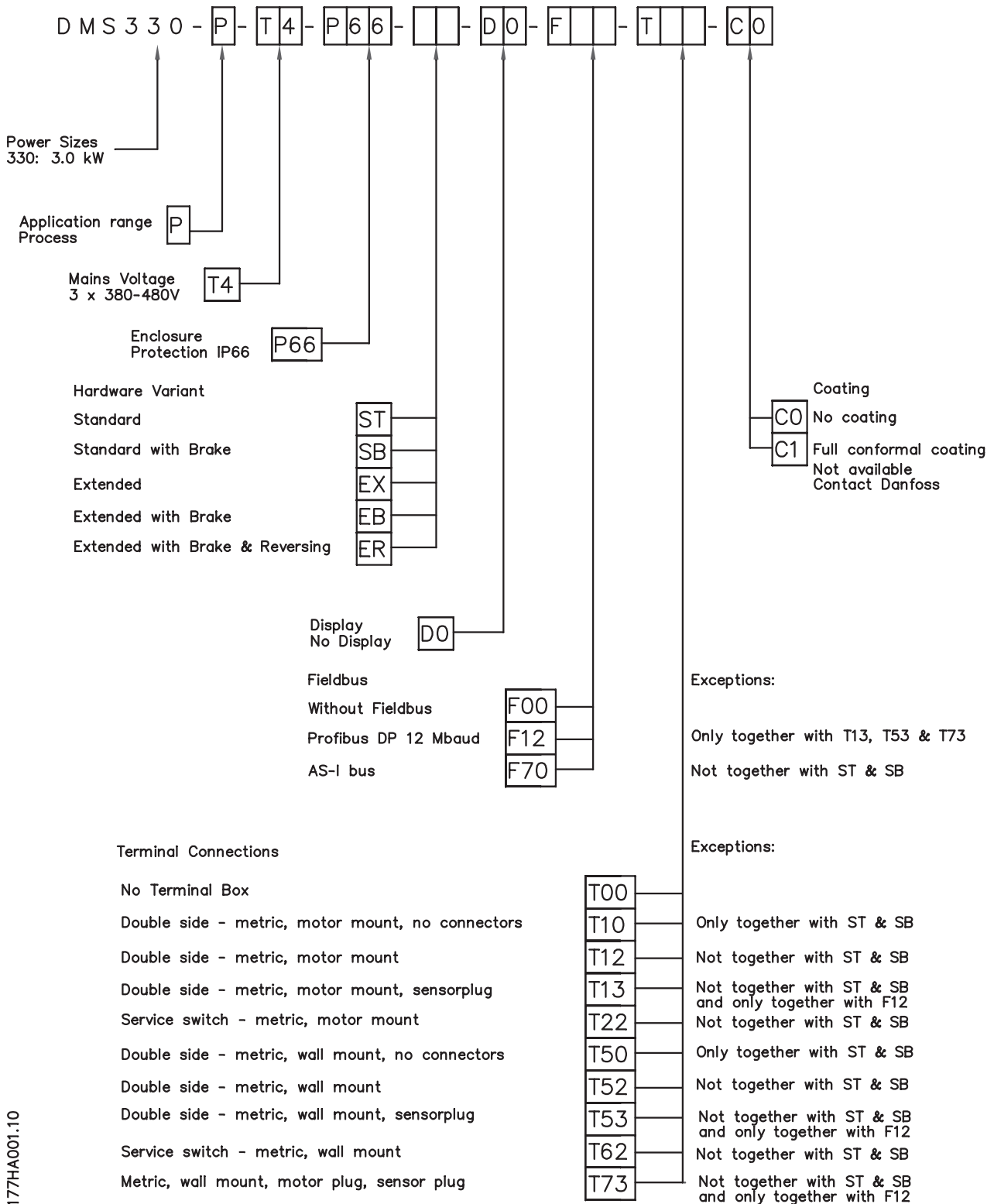

177HA001.10

Special variants:

In addition to the installation boxes described earlier, DMS units can be offered as variants with additional functionality and options

Example 1

Variant T73: DMS Extended unit with Profibus communication option, 4 x M12 sensor plugs (as described above) plus a special Harting connector for motor connections.



Picture of DMS Unit with Profibus card, with 4 x M12 connectors for sensors, and Harting connector for Motor connections

Motor connection

The motor must be connected by a Han 10E connector according to the DESINA standard.

Pin no.	Function	Pin no.	Function
1	Motor U	6 – 8	Not connected
2	Motor V	9	Motor thermistor A
3	Motor W	10	Motor thermistor B
4	Electromechanical brake A	PE	Earth connection
5	Electromechanical brake B		

Example 2

Variant T22 or T62: DMS Extended unit with an integrated service switch.

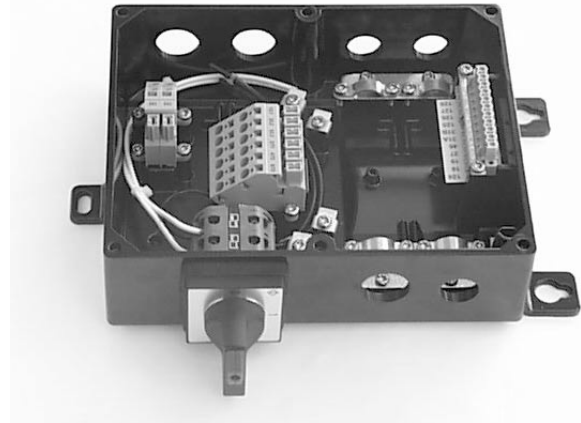

Specification and order codes

The service switch can either be connected between the mains supply & DMS unit, or between DMS unit and the motor, as shown here.

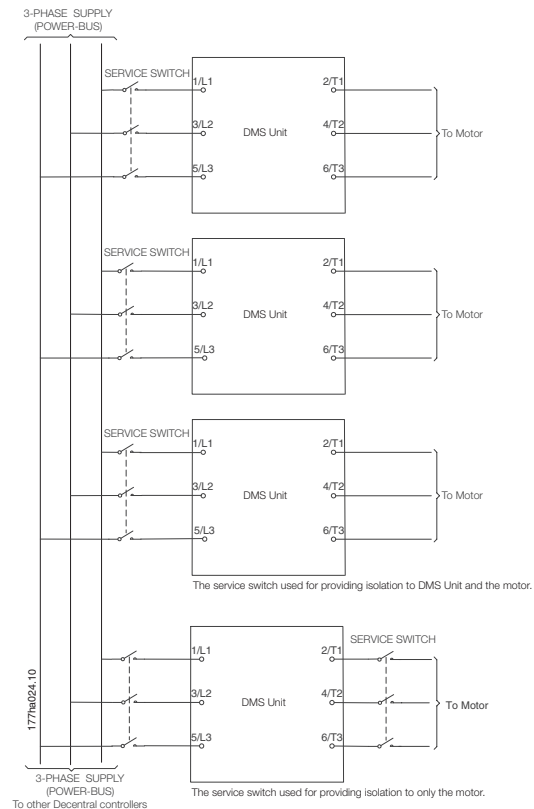

Examples of connection of Service switch

■ Details of Profibus Connectivity



NB!:

When using Profibus interface, the complete control of the DMS is done by the Profibus. The DMS control terminals cannot be used.

■ Profibus DP Slave 6 E/DC 24 V, 4 A/DC 24 V/1A

connection	bus connection	spring terminal block 2 x 2 x 2.5sq.mm. 69: A-Line RxD/TxD-N, green wire 68:B-Line RxD/TxD-P, red wire
	termination	switchable, SW2 both on
supply power to the module	voltage range incl. ripple	20-30VDC
	ripple	max. 10%
	current consumption	nom. 90 mA
supply power input and output	connection	spring terminal block 2 x 2 x 2.5sq.mm. 201: DC 0 V, 202:DC 24 V
	voltage range incl. ripple	20-30VDC
galvanic isolation	connection	spring terminal block 2 x 2 x 2.5sq.mm. 203: DC 0 V, 204:DC 24 V
	isolation voltage	DC 500 V between bus and electronics DC 2.5kV between module supply and inputs/ outputs
Bus interface	Bus system	Profibus DP
	module type	Slave I/O module
	standard	DIN 19245
	data width in the process image	1 Byte inputs, 1 Byte outputs
	fieldbus controller	LSPM2
	identifier	0409 hex
	addressing	Node ID: 1-99 set by DIP switch SW3
	baud rate	up to 12Mbaud, automatic detection

■ Table of bits in control and status word

	Terminal connection	Function	Profibus control word	Profibus status word
Output 1	18	Start CW	Bit 0	
Output 2	19	Start CCW	Bit 1	
Output 3	27	Reset/ Coasting stop inverse	Bit 2	
0 V	125 (203)			
+ 24 V	126 (204)			
Input 1	M12, I1	Input		Bit 0
Input 2	M12, I2	Input		Bit 1
Input 3	M12, I3	Input		Bit 2
Input 4	M12, I4	Input		Bit 3
Input 5	46	Ready		Bit 4

The GSD file is available on the internet at
www.danfoss.com/drives

■ **Profibus connector PCB 4 x M12**

inputs	number	4 x M12 female socket IP67
	connection	M12 female socket Pin 1: DC 24 V Pin 2: NC (not connected) Pin 3: DC 0 V Pin 4: input

Specification and
order codes

■ **Profibus address setting: DIP switch SW3**

Address decimal	DIP 1	DIP 2	DIP 3	DIP 4	DIP 5	DIP 6	DIP 7	DIP 8
x 0	1	1	1	1	x	x	x	x
x 1	0	1	1	1	x	x	x	x
x 2	1	0	1	1	x	x	x	x
x 3	0	0	1	1	x	x	x	x
x 4	1	1	0	1	x	x	x	x
x 5	0	1	0	1	x	x	x	x
x 6	1	0	0	1	x	x	x	x
x 7	0	0	0	1	x	x	x	x
x 8	1	1	1	0	x	x	x	x
x 9	0	1	1	0	x	x	x	x
0 x	x	x	x	x	1	1	1	1
1 x	x	x	x	x	0	1	1	1
2 x	x	x	x	x	1	0	1	1
3 x	x	x	x	x	0	0	1	1
4 x	x	x	x	x	1	1	0	1
5 x	x	x	x	x	0	1	0	1
6 x	x	x	x	x	1	0	0	1
7 x	x	x	x	x	0	0	0	1
8 x	x	x	x	x	1	1	1	0
9 x	x	x	x	x	0	1	1	0

The address 00 is not allowed. Also all positions not listed in the table are not allowed. In those cases address 126dec is used.

A

Avoiding DMS damage..... 3

B

Brake Release..... 12

C

Certification 17

Construction..... 4

Control Wiring 6

Current Ratings (AC53a ratings) 15

D

Derating curve for altitude 5

Derating curve for temperature..... 5

Description 4

Description of AS-i profiles used with DMS 12

E

Earthing 7

Electrical Schematic 8

F

Fault Procedure 14

FLC setting table 11

Full Load Current setting: 10

Fuses..... 17

G

Galvanic isolation (PELV)..... 7

General layout 4

General Technical Data 15

H

Han 10E connector 19

High voltage warning 7

M

Motor mounting..... 4

Motor thermistors 7

O

Operation..... 12

Operation with AS-i Interface 12

Order code format 18

P

Power factor correction 6

Power Wiring 6

Powering-up the DMS 12

Profibus address setting: DIP switch SW3 21

R

Reading the "Alarm" LED 14

Replacing a faulty unit 14

S

Safety regulations 3

Serial communication..... 7

Service switch..... 19

Special variants: 19

Start/ Stop profile..... 9

Starting the motor 12

Symbols used in this manual 3

T

Tools required 4

Trip Class selection 10

Trip Class selection table 10

V

Ventilation 4

Version no. 3

W

Wall mounting 4



Decentral Motor Starter DMS 300



Operating Instructions

VLT[®] frequency converters **BAUER** geared motors

Danfoss can accept no responsibility for possible errors in catalogues, brochures and other printed material. Danfoss reserves the right to alter its products without notice. This also applies to products already on order provided that such alterations can be made without subsequential changes being necessary in specifications already agreed. All trademarks in this material are property of the respective companies. Danfoss and the Danfoss logotype are trademarks of Danfoss A/S. All rights reserved.

