

Contents

■ How to Read this Instruction Manual	3
□ Approvals	5
□ Symbols	5
□ Abbreviations	6
■ Safety Instructions and General Warning	7
□ High voltage warning	7
□ Safety Instructions	7
□ High start torque	7
□ IT Mains	8
■ How to Install	9
□ How to Get Started	9
□ Accessory Bag	10
□ Mechanical Installation	11
□ Electrical Installation	12
□ Connection to Mains and Grounding	12
□ Motor Connection	13
□ Motor cables	14
□ Fuses	15
□ Access to Control Terminals	17
□ Electrical Installation, Control Terminals	17
□ Control Terminals	18
□ Electrical Installation, Control Cables	19
□ Switches S201, S202, and S801	20
□ Tightening Torque	21
□ Final Set-Up and Test	21
□ Additional Connections	23
□ 24 V Backup Option	23
□ Load Sharing	23
□ Brake Connection Option	24
□ Relay connection	25
□ Control of Mechanical Brake	25
□ Thermal motor protection	26
■ How to Program	27
□ The Local Control Panel	27
□ How to Program on the Local Control Panel	27
□ Quick Transfer of Parameter Settings	29
□ Reset to Default Setting	29
□ Adjust Display Contrast	30
□ How to Connect a PC to the FC 300	30
□ The FC 300 Software Dialog	30
□ Connection Examples	31
□ Start/stop	31
□ Pulse start/stop	31
□ Speed up/slow down	31

□ Potentiometer reference	31
□ Basic Parameters	32
□ Parameter lists	35
■ General Specifications	49
■ Troubleshooting	55
□ Warnings/Alarm Messages	55
■ Index	63

How to Read this Instruction Manual

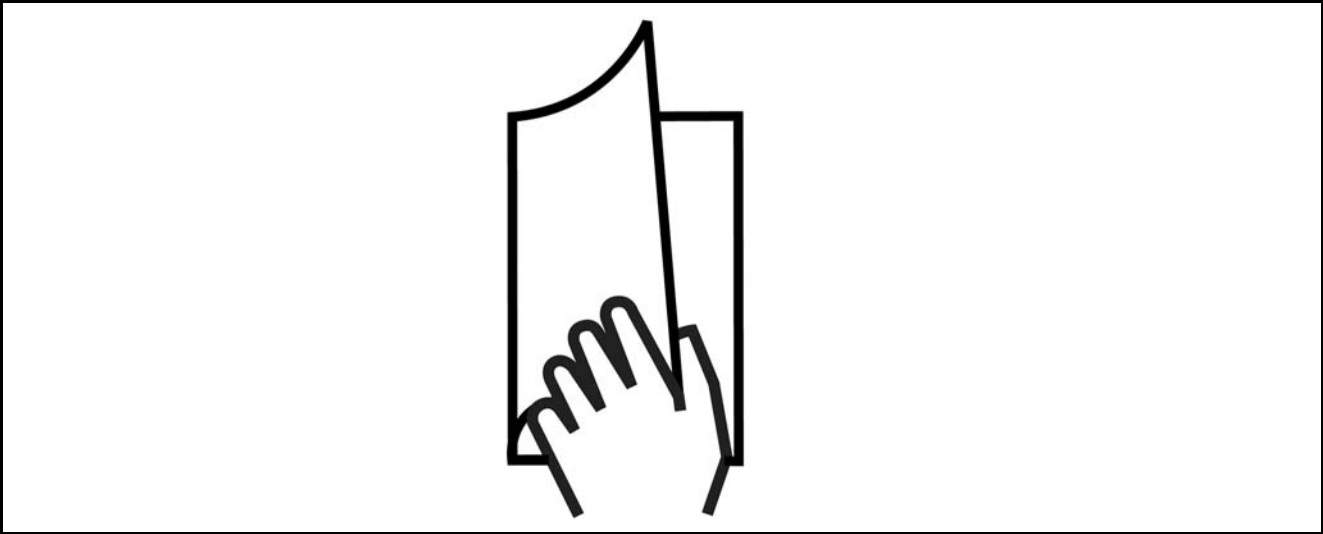

□ **How to Read this Instruction Manual**

This Instruction Manual will help you get started, install, program, and troubleshoot your VLT® AutomationDrive FC 300.

The FC 300 comes in two shaft performance levels. FC 301 ranges from scalar (U/f) to VVC+, and FC 302 ranges from scalar (U/f) to servo performance.

This Instruction Manual covers both FC 301 and FC 302. Where information covers both series, we refer to FC 300. Otherwise, we refer specifically to either FC 301 or FC 302.

Chapter 1, **How to Read this Instruction Manual**, introduces the manual and informs you about the approvals, symbols, and abbreviations used in this literature.

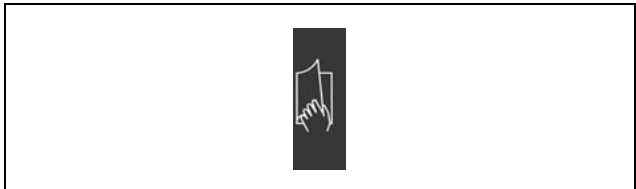

Page divider for How to Read this Instruction Manual.

Chapter 2, **Safety Instructions and General Warnings**, entails instructions on how to handle the FC 300 correctly.

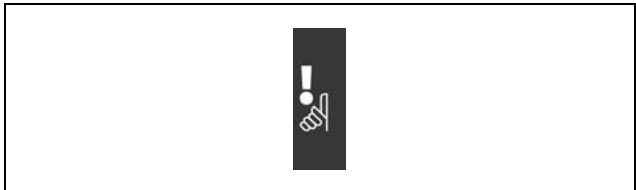

Page divider for Safety Instructions and General Warnings.

— How to Read this Instruction Manual —



Chapter 3, **How to Install**, guides you through mechanical and technical installation.

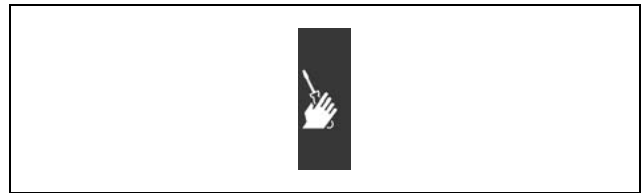

Page divider for How to Install

Chapter 4, **How to Program**, shows you how to operate and program the FC 300 via the Local Control Panel.

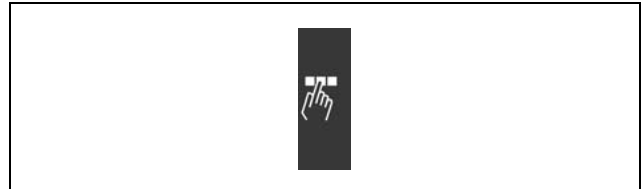

Page divider for How to Program.

Chapter 5, **General Specifications**, entails technical data about FC 300.



Page divider for General Specifications.

Chapter 6, **Troubleshooting**, assists you in solving problems that may occur when using FC 300.



Page divider for Troubleshooting.

Available literature for FC 300

- The VLT® AutomationDrive FC 300 Instruction Manual provides the necessary information for getting the drive up and running.
- The VLT® AutomationDrive FC 300 Design Guide entails all technical information about the drive and customer design and applications.
- The VLT® AutomationDrive FC 300 Profibus Operating Instructions (Instruction Manual) provide the information required for controlling, monitoring, and programming the drive via a Profibus fieldbus.
- The VLT® AutomationDrive FC 300 DeviceNet Operating Instructions (Instruction Manual) provide the information required for controlling, monitoring, and programming the drive via a DeviceNet fieldbus.
- The VLT® AutomationDrive FC 300 MCT 10 Operating Instructions (Instruction Manual) provide information for installation and use of the software on a PC.
- The VLT® AutomationDrive FC 300 IP21 / TYPE 1 Instruction provides information for installing the IP21 / TYPE 1 option.
- The VLT® AutomationDrive FC 300 24 V DC Backup Instruction provides information for installing the 24 V DC Backup option.

Danfoss Drives technical literature is also available online at www.danfoss.com/drives.

□ **Approvals**



□ **Symbols**

Symbols used in these Operating Instructions.



NOTE

Indicates something to be noted by the reader



Indicates a general warning.



Indicates a high voltage warning

* Indicates default setting

— How to Read this Instruction Manual —

□ **Abbreviations**



Alternating current	AC
American Wire Gauge.	AWG
Ampere/AMP	A
Automatic Motor Adaptation	AMA
Current limit	I_{LIM}
Degrees celcius	°C
Direct current	DC
Electronic Thermistor Relay	ETR
Adjustable Frequency Drive	AFD
Gram	G
Hertz	Hz
Kilohertz	kHz
Local Control Panel	LCP
Meter	m
Milliampere	mA
Millisecond	ms
Minute	min
Motion Control Tool	MCT
Nanofarad	nF
Newton Meters	Nm
Nominal motor current	$I_{M,N}$
Nominal motor frequency	$f_{M,N}$
Nominal motor power	$P_{M,N}$
Nominal motor voltage	$U_{M,N}$
Parameter	par.
Rated Inverter Output Current	I_{INV}
Revolutions Per Minute	rpm
Second	S
SLC	Smart Logic Control
Torque limit	T_{LIM}
Volts	V

Safety Instructions and General Warning

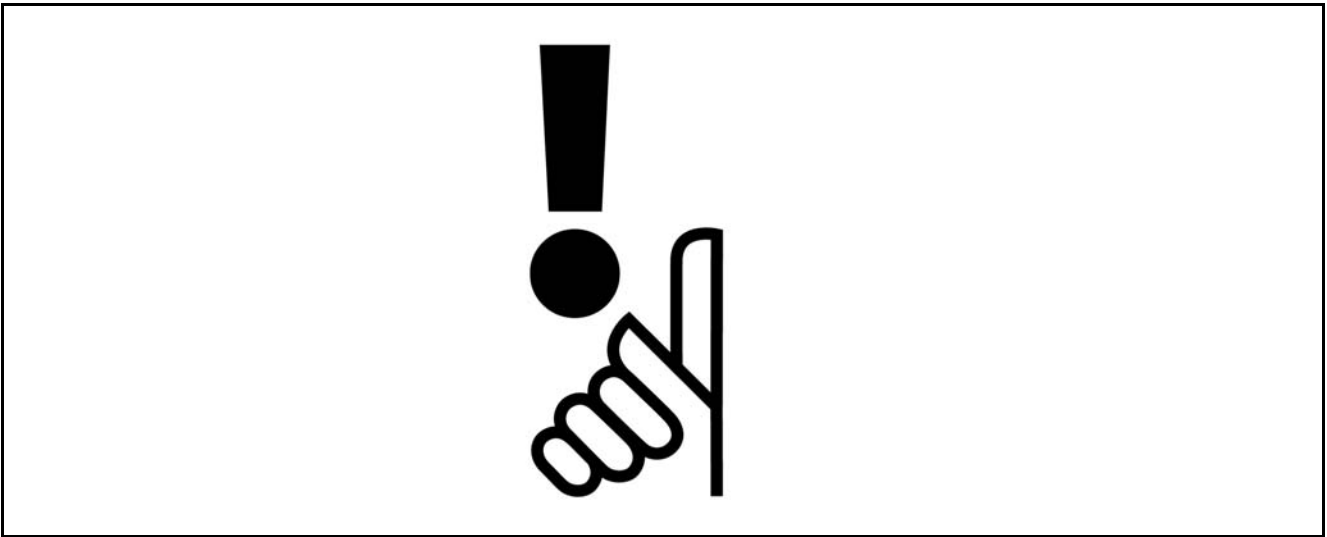

□ High voltage warning



The voltage of the FC 300 is dangerous whenever the converter is connected to electrical power. Incorrect fitting of the motor or adjustable frequency drive may cause damage to the equipment, serious injury or death. Consequently, it is essential to comply with the instructions in this manual as well as local and national rules and safety regulations.

□ Safety Instructions

- Make sure the FC 300 is properly connected to ground.
- Do not remove mains plugs or motor plugs while the FC 300 is connected to mains.
- Protect users against supply voltage.
- Protect the motor against overloading according to national and local regulations.
- Motor overload protection is not included in the default settings. To add this function, set parameter 1-90 *Motor thermal protection* to value *ETR trip* or *ETR warning*. For the North American market: ETR functions provide class 20 motor overload protection, in accordance with NEC.
- The ground leakage current exceeds 3.5 mA.
- The [OFF] key is not a safety switch. It does not disconnect the FC 300 from mains.

□ Before commencing repair work

1. Disconnect FC 300 from AC line.
2. Disconnect DC bus terminals 88 and 89
3. Wait at least 4 minutes
4. Remove motor plugs

□ High start torque

While FC 300 is connected to AC line, the motor can be started/stopped using digital commands, bus commands, references or a local stop.

- Disconnect the FC 300 from AC line whenever personal safety considerations make it necessary to avoid unintended start.

— Safety Instructions and General Warning —

- To avoid unintended start, always activate the [OFF] key before changing parameters.
- Unless terminal 37 is turned off, an electronic fault, temporary overload, a fault in the AC line supply, or lost motor connection may cause a stopped motor to start.

General warning



Warning:

130BA024.10

Touching the electrical parts may be fatal - even after the equipment has been disconnected from the power supply.

Also make sure that other voltage inputs have been disconnected, such as load-sharing (linkage of DC intermediate circuit), as well as the motor connection for kinetic back-up.

Using VLT AutomationDrive FC 300 (at and below 7.5 kW):

wait at least 4 minutes



Leakage Current

The ground leakage current from the FC 300 exceeds 3.5 mA. To ensure that the ground cable has a good mechanical connection to the ground connection (terminal 95), the cable cross section must be at least 0.4 in² (10 mm²) or 2 rated ground wires terminated separately.

Residual Current Device

This product can cause a D.C. current in the protective conductor. Where a residual current device (RCD) is used for extra protection, only an RCD of Type B (time delayed) shall be used on the supply side of this product. See also RCD Application Note MN.90.GX.02.

Protective grounding of the FC 300 and the use of RCD's must always follow national and local regulations.

□ IT Mains



Do not connect 400-V units with RFI-filters to electrical supplies with a voltage between phase and ground of more than 440 V. For IT AC line and delta ground (grounded leg), AC line voltage may exceed 440 V between phase and ground.

Par. 14-50 *RFI 1* can be used to disconnect the internal RFI capacities from the intermediate circuit.

How to Install

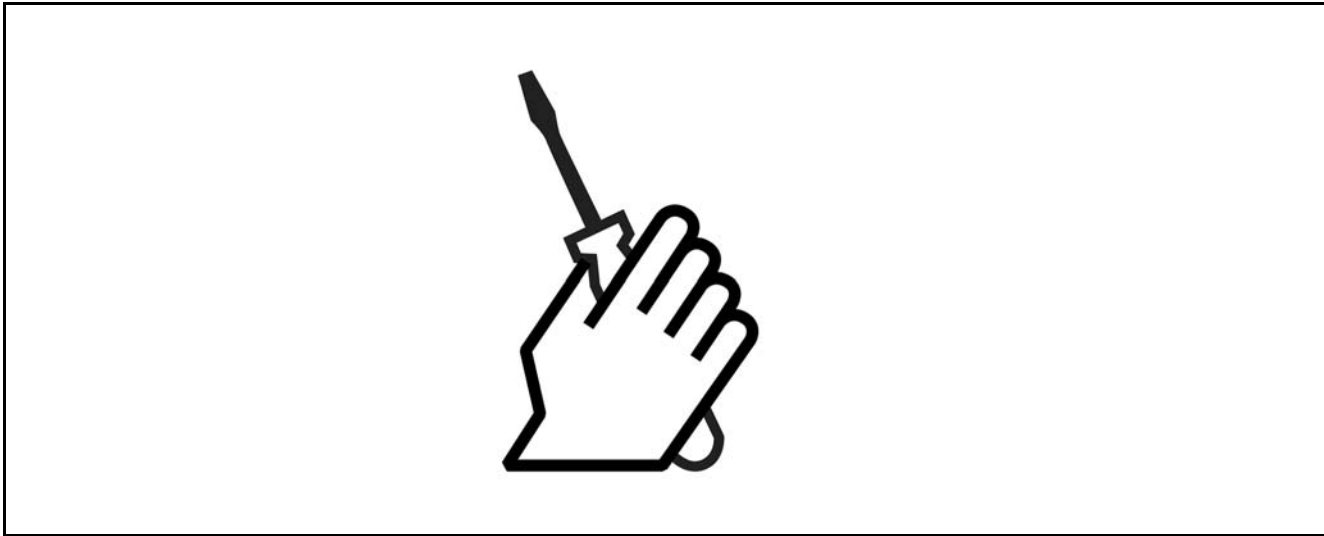

□ **About How to Install**

This chapter covers mechanical and electrical installations to and from power terminals and control card terminals.

Electrical installation of *options* is described in the corresponding Instructions.

□ **How to get started**

You can carry out a quick and EMC-correct installation of the FC 300 by following the steps described below.



Read the safety instructions before installing the unit.

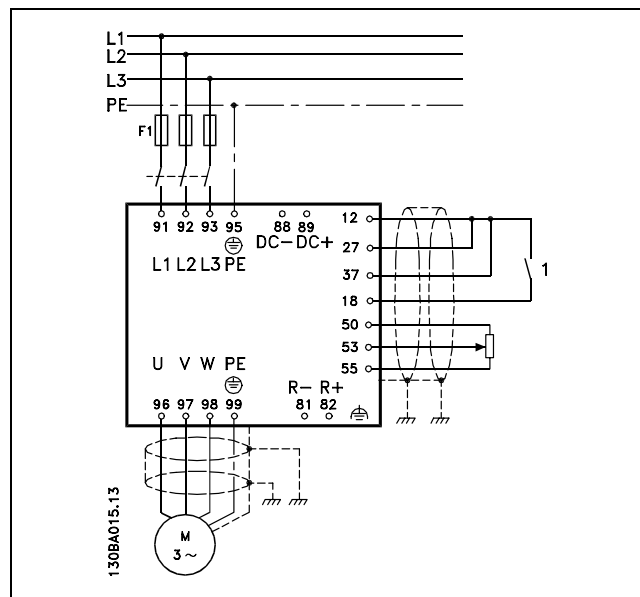
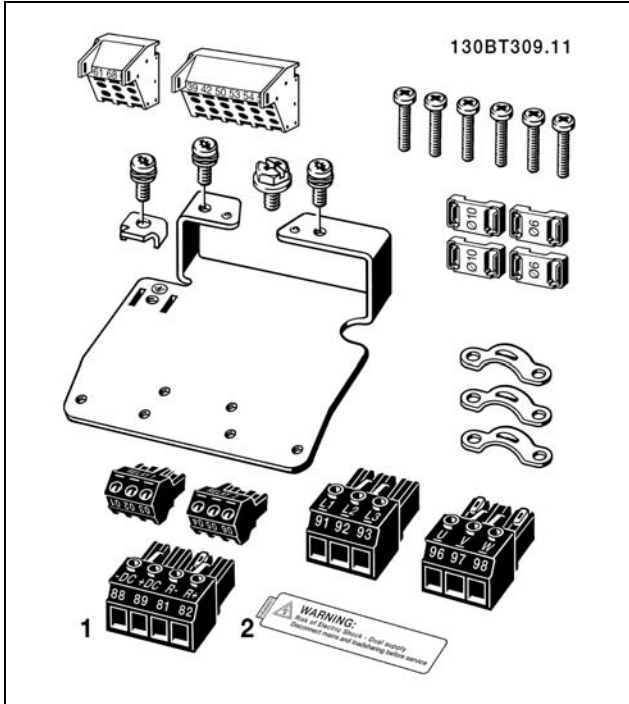

Diagram showing basic installation including, electrical connection, motor, start/stop key, and potentiometer for speed adjustment.

— How to Install —

□ **Accessory Bag**

Find the following parts included in the FC 300 Accessory Bag.



1 + 2 only available in units with brake chopper.

□ **Mechanical Installation**

Mechanical dimensions			
		Frame size B 0.34-3.0 HP (0.25-2.2 kW) (200-240 V)	Frame size C 4.0-5.0 HP (3.0-3.7 kW) (200-240 V)
		0.5-5.4 HP (0.37-4.0 kW) (380-500 V)	7.4-10 HP (5.5-7.5 kW) (380-500 V)
			1.0-10 HP (0.75-7.5 kW) (550-600 V)
Height			
Height of back plate	A	10.6 in (268 mm)	10.6 in (268 mm)
Distance between mounting holes	a	10.1 in (257 mm)	10.1 in (257 mm)
Width			
Width of back plate	B	3.54 in (90 mm)	5.12 in (130 mm)
Distance between mounting holes	b	2.76 in (70 mm)	4.33 in (110 mm)
Depth			
From back plate to front	C	8.66 in (220 mm)	8.66 in (220 mm)
With option A/B		8.66 in (220 mm)	8.66 in (220 mm)
Without options		8.07 in (205 mm)	8.07 in (205 mm)
Screw holes			
	c	0.315 in (8.0 mm)	0.315 in (8.0 mm)
	d	ø 0.433 in (ø 11 mm)	ø 0.433 in (ø 11 mm)
	e	ø 0.217 in (ø 5.5 mm)	ø 0.217 in (ø 5.5 mm)
	f	0.256 in (6.5 mm)	0.256 in (6.5 mm)
Max weight			
		10.2 lb (4.9 kg)	14.6 lb (6.6 kg)

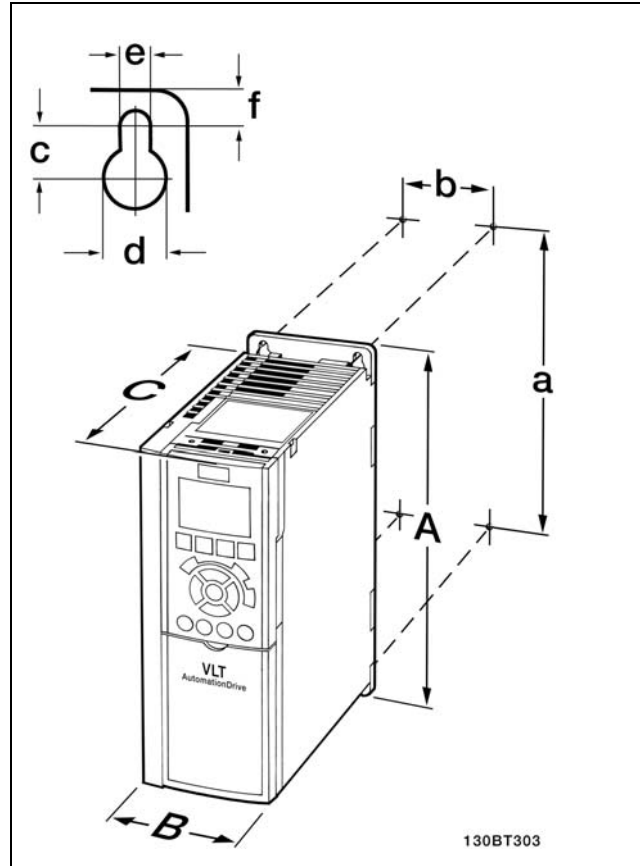

FC 300 IP20 - see accompanying table for mechanical dimensions.

1. Drill holes in accordance with the measurements given.
2. You must provide screws suitable for the surface on which you want to mount the FC 300. Retighten all four screws.

— How to Install —

For installation of IP21/TYPE 1/IP4X top and bottom - see the Option Guide enclosed with the FC 300.

FC 300 IP20 allows side-by-side installation. Because of the need for cooling, there must be a minimum of 4 in (100 mm) free air passage above and below the FC 300.

□ **Electrical Installation**

□ **Connection to Mains and Grounding**



NOTE

The plug connector for power can be removed.

1. Make sure the FC 300 is properly grounded. Connect to ground connection (terminal 95). Use screw from the accessory bag.
2. Place plug connector 91, 92, 93 from the accessory bag onto the terminals labeled MAINS at the bottom of FC 300.
3. Connect mains wires to the mains plug connector.



The ground connection cable cross-section must be at least 0.015 in.² (10 mm²) or 2 rated mains wires terminated separately.

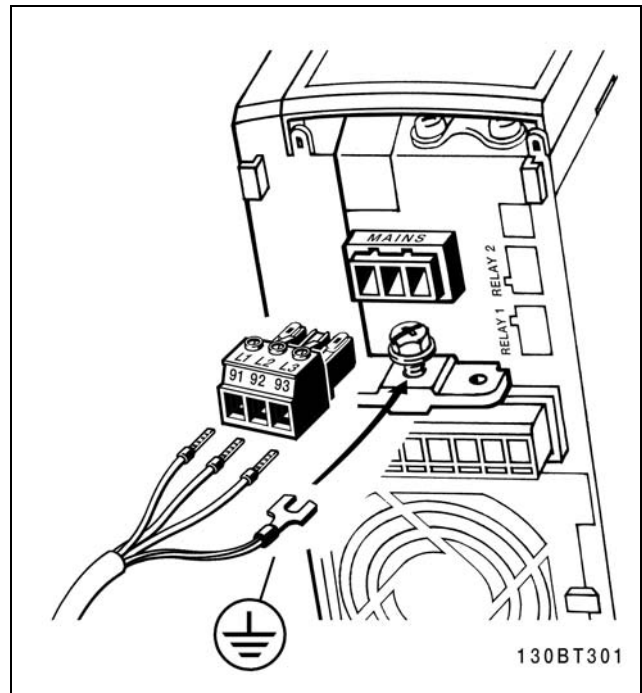

How to connect to mains and grounding.



NOTE

Check that mains voltage corresponds to the mains voltage of the FC 300 nameplate.



Do not connect 400-V units with RFI-filters to electrical supplies with a voltage between phase and ground of more than 440 V. For IT AC line and delta ground (grounded leg), AC line voltage may exceed 440 V between phase and ground.

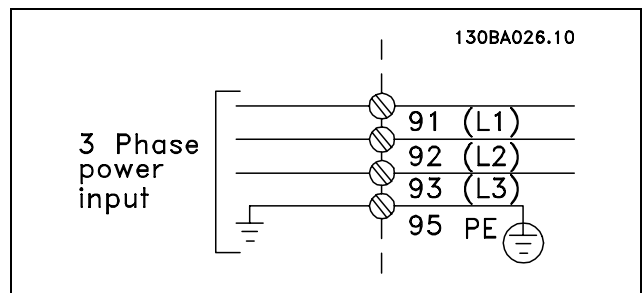

Terminals for mains and grounding.

— How to Install —

□ **Motor Connection**



NOTE

Motor cable must be shielded/armored. If a non-shielded/unarmored cable is used, some EMC requirements are not complied with. For more information, see *EMC specifications* in the *VLT AutomationDrive FC 300 Design Guide*.

1. Fasten decoupling plate to the bottom of FC 300 with screws and washers from the accessory bag.

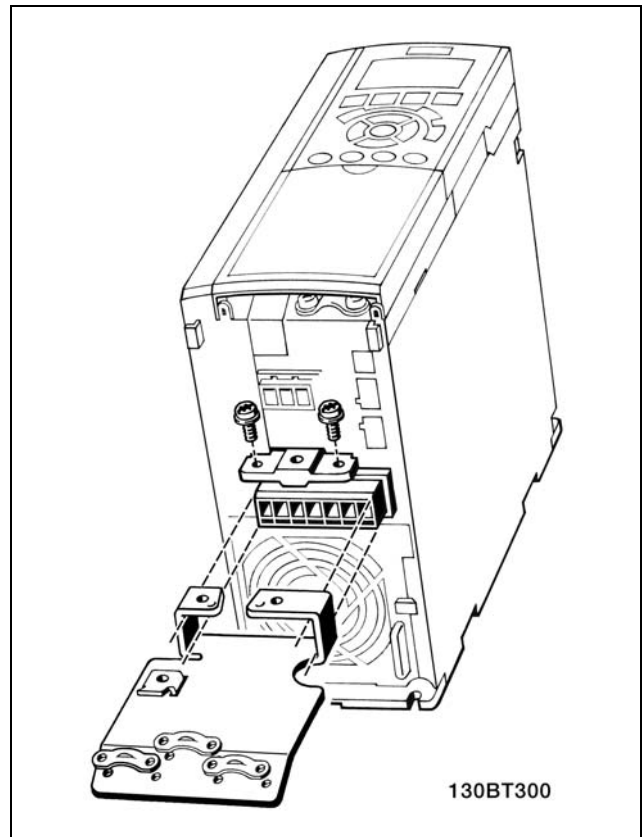

2. Attach motor cable to terminals 96 (U), 97 (V), 98 (W).
3. Connect to ground connection (terminal 99) on decoupling plate with screws from the accessory bag.
4. Insert plug connectors 96 (U), 97 (V), 98 (W) and motor cable to terminals labeled MOTOR.
5. Fasten shielded cable to decoupling plate with screws and washers from the accessory bag.

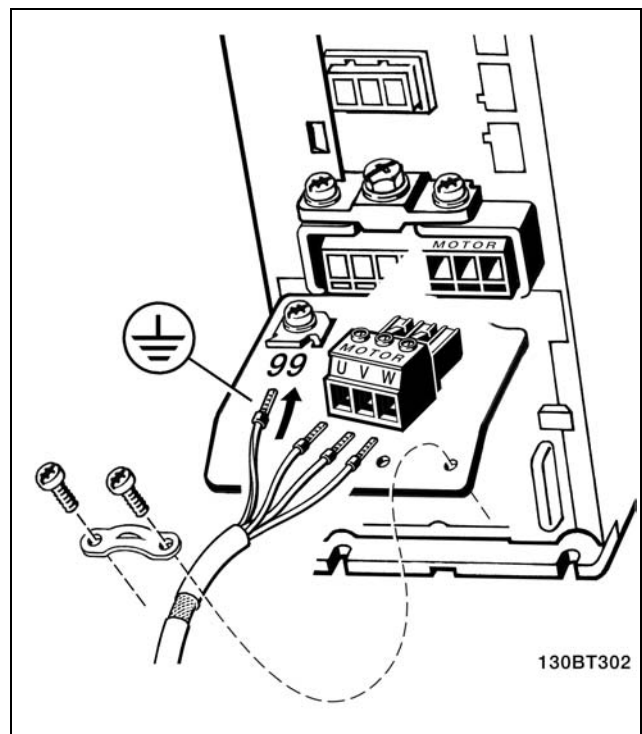

— How to Install —

No.	96	97	98	Motor voltage 0-100% of mains voltage. 3 wires out of motor
	U	V	W	
	U1 W2	V1 U2	W1 V2	6 wires out of motor, delta-connected
	U1	V1	W1	6 wires out of motor, star-connected U2, V2, W2 to be interconnected separately
No.	99			Ground connection
	PE			

All types of three-phase asynchronous standard motors can be connected to the FC 300. Normally, small motors are star-connected (230/400 V, Δ/Y). Large motors are normally delta-connected (400/690 V, Δ/Y). Refer to the motor nameplate for correct connection mode and voltage.

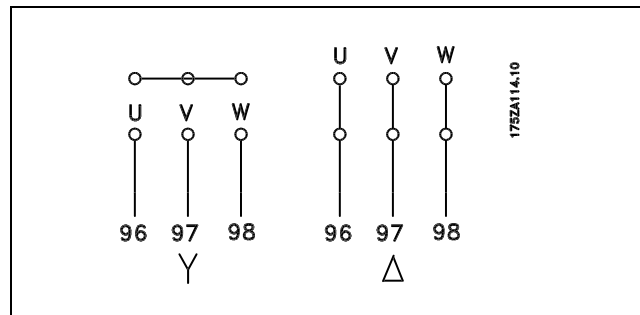

NOTE

In motors without phase insulation paper or other insulation reinforcement suitable for operation with voltage supply (such as an adjustable frequency drive), fit an LC filter on the output of the FC 300.

□ **Motor cables**

See Technical data for correct sizing of motor cable cross-section and length. Always comply with national and local regulations on cable cross-section.

- Use a shielded/armoured motor cable to comply with EMC emission specifications unless otherwise stated for the RFI filter used.
- Keep the motor cable as short as possible to reduce the noise level and leakage currents.
- Connect the motor cable shield to the decoupling plate of the FC 300 and to the metal cabinet of the motor.
- Make the shield connections with the largest possible surface area (cable clamp). This is done by using the supplied installation devices in the FC 300.
- Avoid mounting with twisted screen ends (pigtailed), which will spoil high frequency screening effects.
- If it is necessary to split the shield to install a motor isolator or motor relay, the shield must be continued with the lowest possible high frequency impedance.

— How to Install —

□ **Fuses**

Branch circuit protection:

In order to protect the installation against electrical and fire hazard, all branch circuits in an installation, switch gear, machines etc., must be short circuit- and overcurrent-protected according to the national/international regulations.

Short circuit protection:

The adjustable frequency drive must be protected against short circuit to avoid electrical or fire hazard. Danfoss recommends using the fuses mentioned below to protect service personnel and other equipment in case of an internal failure in the drive. The adjustable frequency drive provides full short circuit protection in case of a short circuit on the motor output.

Overcurrent protection:

Provide overload protection to avoid fire hazard due to overheating of the cables in the installation. The adjustable frequency drive is equipped with an internal overcurrent protection that can be used for upstream overload protection (UL-applications excluded). See par. 4-18. Moreover, fuses or circuit breakers can be used to provide the overcurrent protection in the installation. Overcurrent protection must always be carried out according to national regulations.

To comply with UL/cUL approvals, use pre-fuses according to the tables below.

200-240 V

VLT	Bussmann	Bussmann	Bussmann	SIBA	Littel fuse	Ferraz-Shawmut	Ferraz-Shawmut
	Type RK1	Type J	Type T	Type RK1	Type RK1	Type CC	Type RK1
K2-K75	KTN-R10	JKS-10	JJN-10	5017906-010	KLN-R10	ATM-R10	A2K-10R
1K1-2K2	KTN-R20	JKS-20	JJN-20	5017906-020	KLN-R20	ATM-R20	A2K-20R
3K0-3K7	KTN-R30	JKS-30	JJN-30	5012406-032	KLN-R30	ATM-R30	A2K-30R

380-500 V, 525-600 V

VLT	Bussmann	Bussmann	Bussmann	SIBA	Littel fuse	Ferraz-Shawmut	Ferraz-Shawmut
	Type RK1	Type J	Type T	Type RK1	Type RK1	Type CC	Type RK1
K37-1K5	KTS-R10	JKS-10	JJS-10	5017906-010	KLS-R10	ATM-R10	A6K-10R
2K2-4K0	KTS-R20	JKS-20	JJS-20	5017906-020	KLS-R20	ATM-R20	A6K-20R
5K5-7K5	KTS-R30	JKS-30	JJS-30	5012406-032	KLS-R30	ATM-R30	A6K-30R

KTS fuses from Bussmann may substitute KTN for 240 V adjustable frequency drives.
 FWH fuses from Bussmann may substitute FWX for 240 V adjustable frequency drives.
 KLSR fuses from LITTEL FUSE may substitute KLN-R fuses for 240 V adjustable frequency drives.
 L50S fuses from LITTEL FUSE may substitute L50S fuses for 240 V adjustable frequency drives.
 A6KR fuses from FERRAZ SHAWMUT may substitute A2KR for 240 V adjustable frequency drives.



— How to Install —

A50X fuses from FERRAZ SHAWMUT may substitute A25X for 240 V adjustable frequency drives.

Non-UL compliance

If UL/cUL is not to be complied with, we recommend using the following fuses, which will ensure compliance with EN50178:
 In case of malfunction, not following the recommendation may result in unnecessary damage of the adjustable frequency drive. Fuses must be designed for protection in a circuit capable of supplying a maximum of 100,000 A_{rms} (symmetrical), 500 V maximum.

VLT	Max. fuse size	Voltage	Type
K25-K75	10A ¹⁾	200-240 V	type gG
1K1-2K2	20A ¹⁾	200-240 V	type gG
3K0-3K7	32A ¹⁾	200-240 V	type gG
K37-1K5	10A ¹⁾	380-500V	type gG
2K2-4K0	20A ¹⁾	380-500V	type gG
5K5-7K5	32A ¹⁾	380-500V	type gG

1) Max. fuses - see national/international regulations for selecting an applicable fuse size.



— How to Install —

□ **Access to Control Terminals**

All terminals to the control cables are located underneath the terminal cover on the front of the adjustable frequency drive. Remove the terminal cover by means of a screwdriver (see illustration).

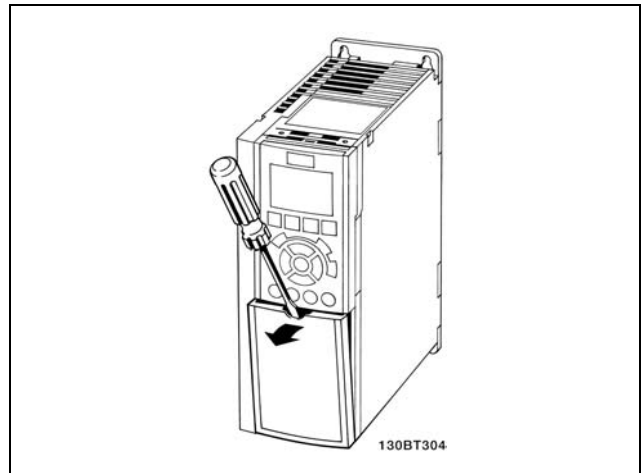

□ **Electrical Installation, Control Terminals**

1. Mount terminals from the accessory bag to the front of the FC 300.
2. Connect terminals 18, 27, and 37 to +24 V (terminal 12/13) with the control cable.

Default settings:

- 18 = start
- 27 = coast inverse
- 37 = safe stop inverse

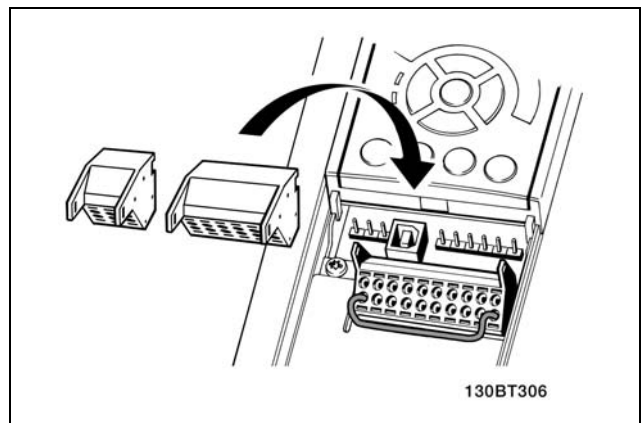

NOTE

To mount the cable to the terminal:

1. Strip isolation of 0.35 - 0.4 in. (9-10 mm)
2. Insert a screwdriver in the square hole.
3. Insert the cable in the adjacent circular hole.
4. Remove the screwdriver. The cable is now mounted to the terminal.

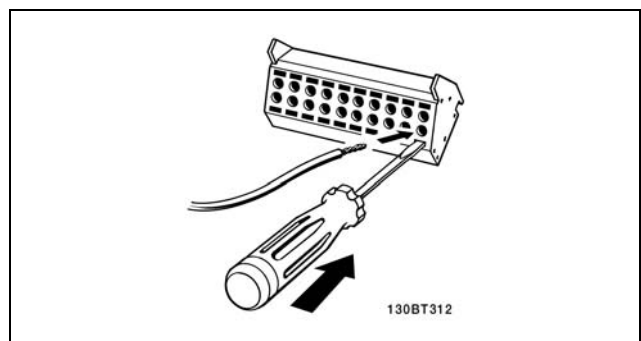

— How to Install —



NOTE

To remove the cable from the terminal:

1. Insert a screwdriver in the square hole.
2. Pull out the cable.

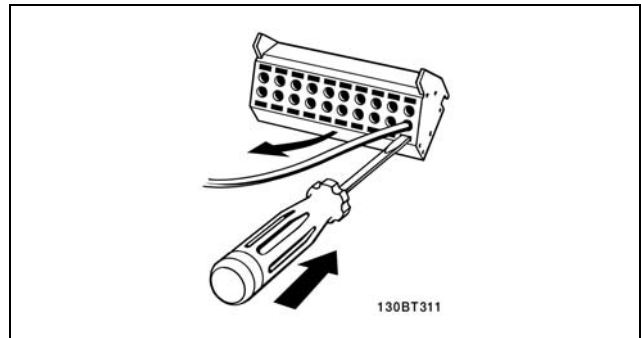

□ **Control Terminals**

Drawing reference numbers:

1. 10 pole plug digital I/O.
2. 3 pole plug RS485 Bus.
3. 6 pole analog I/O.
4. USB Connection.

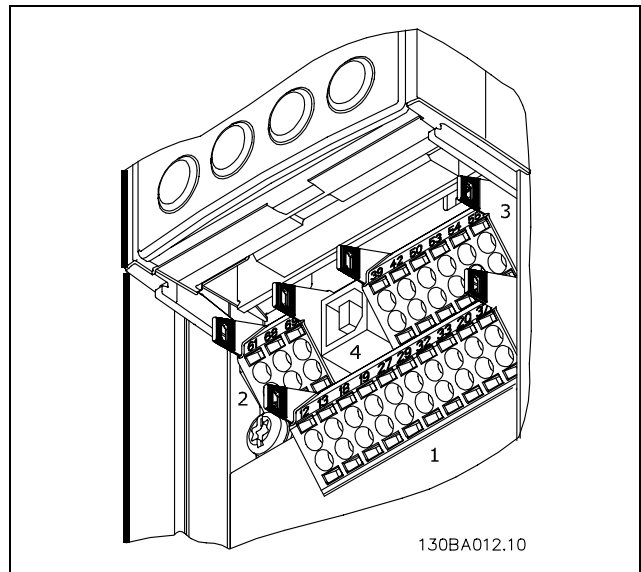

Control terminals

— How to Install —

□ Electrical Installation, Control Cables

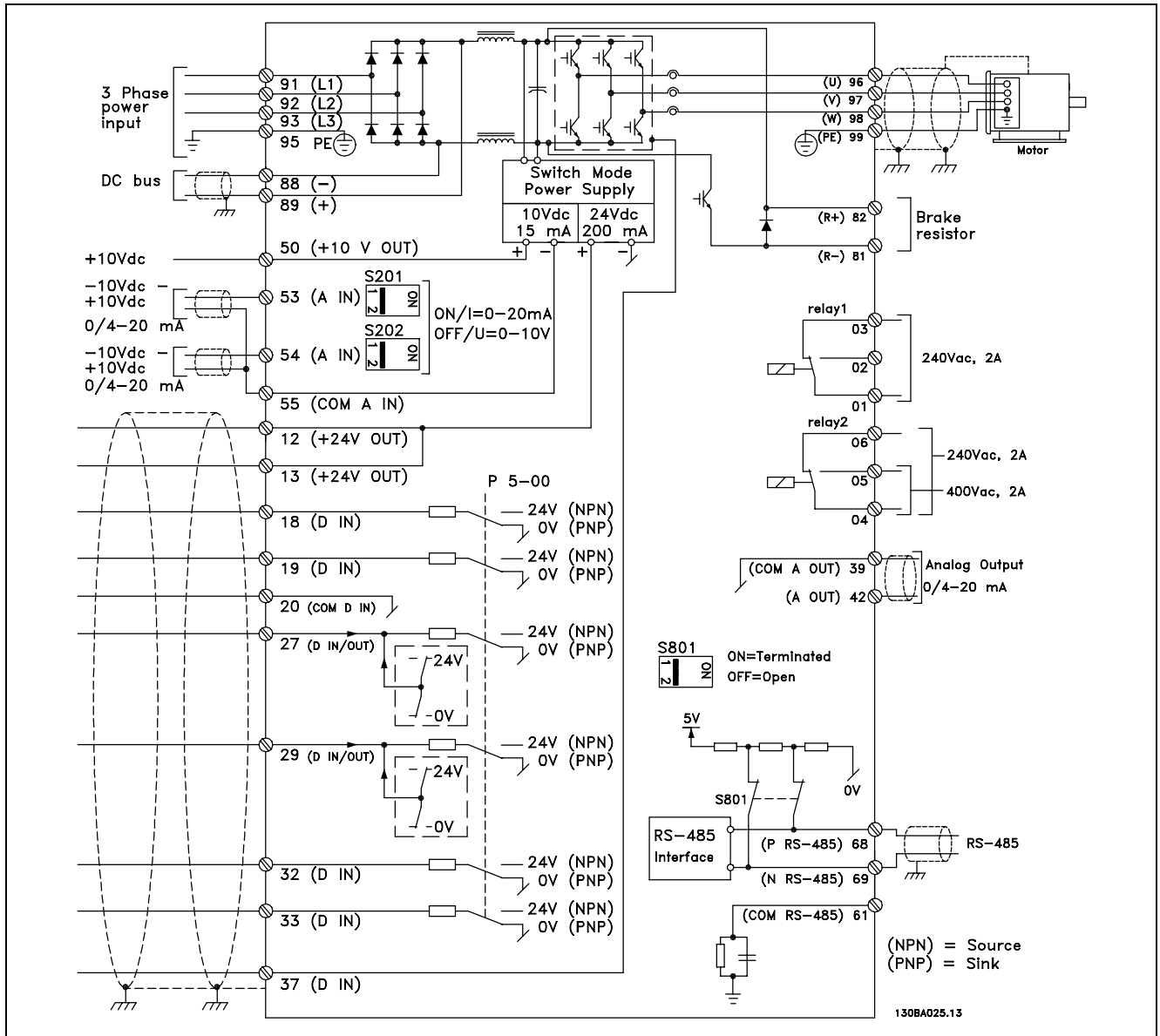

Diagram showing all electrical terminals. Terminal 37 is not included in FC 301.

Very long control cables and analog signals may in rare cases, depending on installation, result in 50/60 Hz ground loops due to noise from mains supply cables.

If this occurs, you may have to break the shield or insert a 100 nF capacitor between shield and chassis.

Common for the digital and analog inputs and outputs must be connected separately to avoid common mode currents from one group (i.e. the digital inputs) to affect other groups (i.e. the analog inputs).

— How to Install —



NOTE

Control cables must be shielded/armored.

1. Use a clamp from the accessory bag to connect the shield to the decoupling plate for control cables.

See section entitled *Grounding of shielded/armored control cables* in the *VLT AutomationDrive FC 300 Design Guide* for the correct termination of control cables.

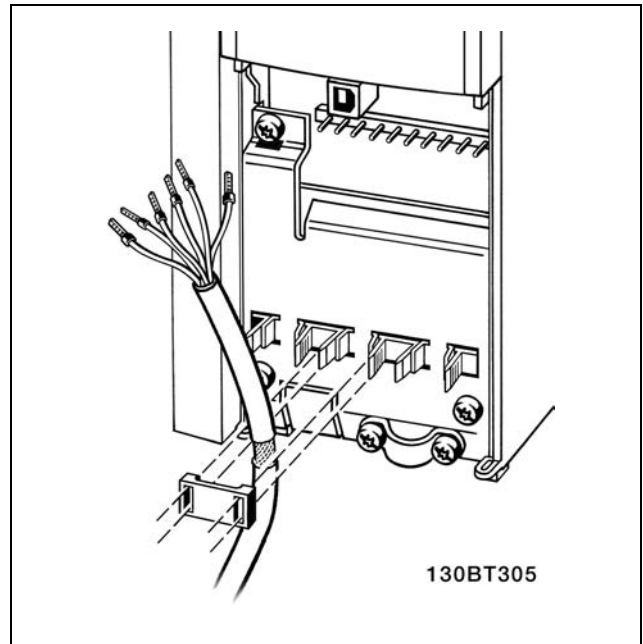

□ **Switches S201, S202, and S801**

Switches S201 (A53) and S202 (A54) are used to select a current (0-20 mA) or a voltage (-10 to 10 V) configuration of the analog input terminals 53 and 54 respectively.

Switch S801 (BUS TER.) can be used to enable termination on the RS-485 port (terminals 68 and 69).

See drawing *Diagram showing all electrical terminals* in section *Electrical Installation*.

Default setting:

- S201 (A53) = OFF (voltage input)
- S202 (A54) = OFF (voltage input)
- S801 (Bus termination) = OFF

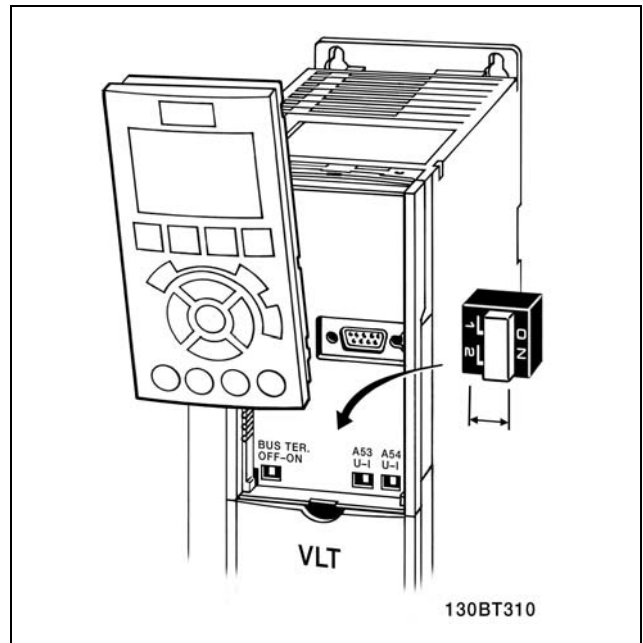

— How to Install —

□ **Tightening Torques**

Tighten connected terminals with the following torques:

FC 300	Connections	Torque (Nm)
	Motor, mains, brake, DC Bus, Decoupling Plate screws	2-3
	Ground, 24 V DC	2-3
	Relay	0.5-0.6

□ **Final Set-Up and Test**

To test the set-up and ensure that the adjustable frequency drive is running, follow these steps.

Step 1. Locate the motor nameplate.



NOTE

The motor is either star- (Y) or delta-connected (Δ). This information is located on the motor nameplate data.

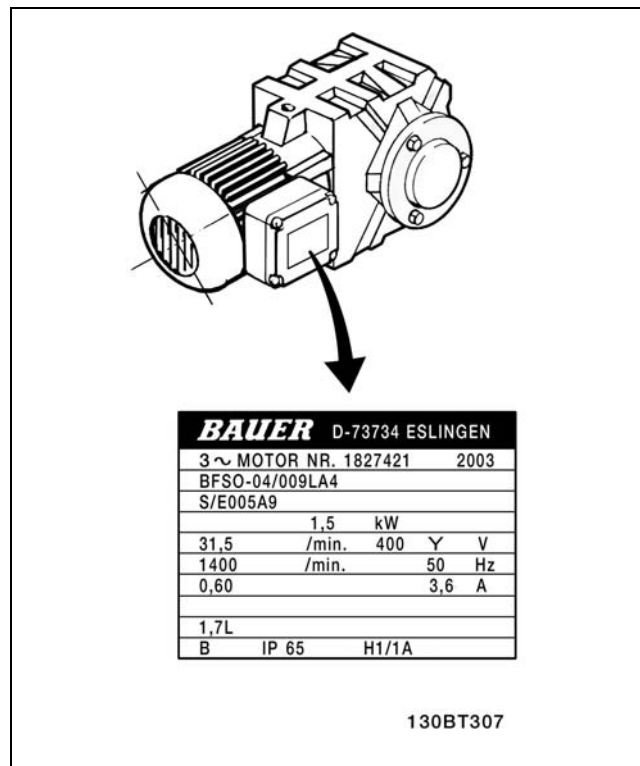

Step 2. Enter the motor nameplate data in this parameter list.

To access this list, first press the [QUICK MENU] key then select "Q2 Quick Setup".

1.	Motor power [kW]	parameter 1-20
2.	Motor voltage	parameter 1-22
3.	Motor frequency	parameter 1-23
4.	Motor current	parameter 1-24
5.	Motor nominal speed	parameter 1-25

— How to Install —

Step 3. Activate the Automatic Motor Adaptation (AMA)

We recommend running an AMA to ensure optimum performance. The AMA measures the values from the motor model equivalent diagram.

1. Connect terminal 37 to terminal 12.
2. Start the adjustable frequency drive and activate the AMA parameter 1-29.
3. Choose between complete or reduced AMA. If an LC filter is mounted, run only the reduced AMA.
4. Press the [OK] key. The display shows "Press hand to start".
5. Press the [Hand on] key. A progress bar placed at the bottom of the display indicates if the AMA is in progress.

Stop the AMA during operation

1. Press the [OFF] key - the adjustable frequency drive enters into alarm mode and the display shows that the AMA was terminated by the user.

Successful AMA

1. The display shows "Press [OK] to finish AMA".
2. Press the [OK] key to exit the AMA state.

Unsuccessful AMA

1. The adjustable frequency drive enters into alarm mode. A description of the alarm can be found in the *Troubleshooting* section.
2. "Report Value" in the [Alarm Log] shows the last measuring sequence carried out by the AMA, before the adjustable frequency drive entered alarm mode. This number along with the description of the alarm will assist you in troubleshooting. If you contact Danfoss Service, make sure to mention number and alarm description.

**NOTE**

Unsuccessful AMA is often caused by incorrectly registered motor nameplate data.

— How to Install —

Step 4. Set speed limit and ramp time

Set up the desired limits for speed and ramp time.

Minimum reference	parameter 3-02
Maximum reference	parameter 3-03

Motor speed low limit	parameter 4-11 or 4-12
Motor speed high limit	parameter 4-13 or 4-14

Ramp-up time 1 [s]	parameter 3-41
Ramp-down time 1 [s]	parameter 3-42

□ **Additional Connections**

□ **24 V Backup Option**

Terminal numbers:

- Terminal 35: - external 24 V DC supply.
- Terminal 36: + external 24 V DC supply.

1. Attach 24 V DC cable to the 24 V plug connector.
2. Insert plug connector into terminals labeled 35, 36.

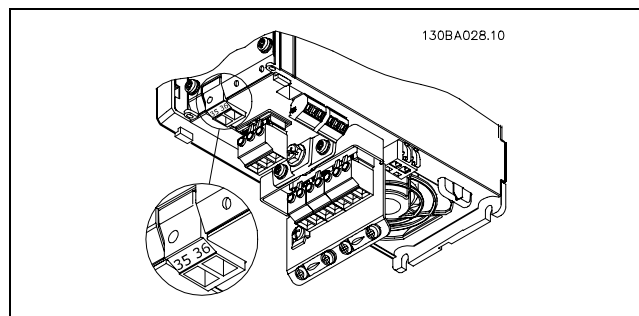

Connection to 24 V backup supply.

□ **Load Sharing**

With load sharing, you can connect several FC 300's DC intermediate circuits if you extend the installation using extra fuses and AC coils (see illustration).

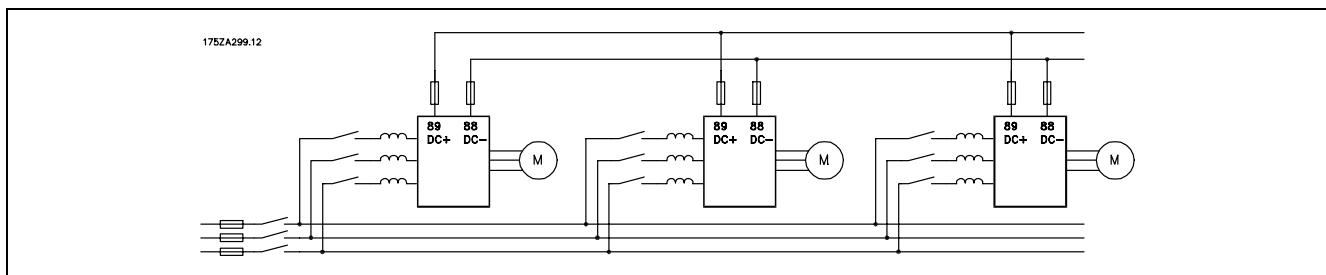

— How to Install —



NOTE

Load sharing cables must be shielded/armored. If a non-shielded/unarmored cable is used, some EMC requirements are not complied with. For more information, see *EMC specifications* in the *VLT AutomationDrive FC 300 Design Guide*.



Voltage levels of up to 975 V DC may occur between terminals 88 and 89.

No.	88	89	Load sharing / DC link
	DC -	DC +	Terminals

□ **Brake Connection Option**

The connection cable to the brake resistor must be shielded/armored.

No.	81	82	Brake resistor
	R-	R+	terminals

1. Use cable clamps to connect the shield to the metal cabinet of the adjustable frequency drive and to the decoupling plate of the brake resistor.
2. Dimension the cross-section of the brake cable to match the brake current.



NOTE

Voltages up to 975 V DC may occur between the terminals.



NOTE

If a short circuit in the brake resistor occurs, prevent power dissipation in the brake resistor by using a mains switch or contactor to disconnect the mains for the adjustable frequency drive. Only the adjustable frequency drive can control the contactor.

— How to Install —

□ **Relay connection**

To set relay output, see parameter group 5-4* Relays.

No.	01 - 02	make (normally open)
	01 - 03	break (normally closed)
	04 - 05	make (normally open)
	04 - 06	break (normally closed)

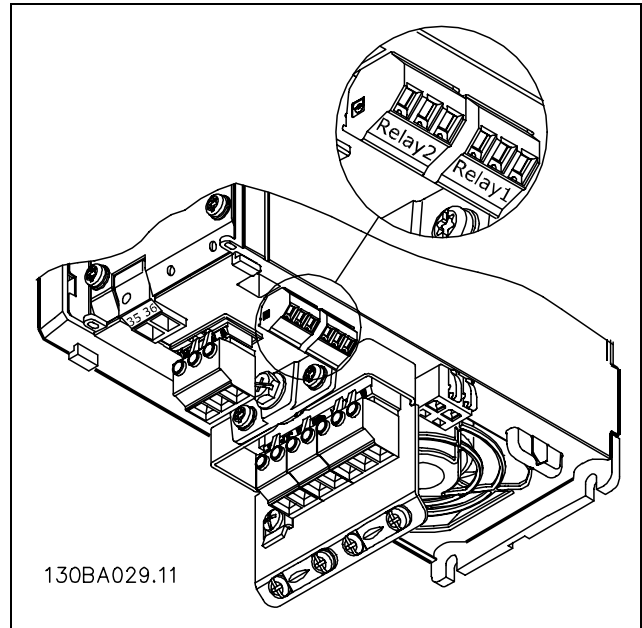

Terminals for relay connection.

□ **Control of Mechanical Brake**

In hoisting/lowering applications, you need to be able to control an electromechanical brake.

- Control the brake using any relay output or digital output (terminal 27 or 29).
- Keep the output closed (voltage-free) as long as the adjustable frequency drive is unable to "support" the motor, for example due to the load being too heavy.
- Select *Mechanical brake control* [32] in par. 5-4* for applications with an electromechanical brake.
- The brake is released when the motor current exceeds the preset value in par. 2-20.
- The brake is engaged when the output frequency is less than the frequency set in par. 2-21 or 2-22, and only if the adjustable frequency drive carries out a stop command.

If the adjustable frequency drive is in alarm mode or in an overvoltage situation, the mechanical brake immediately cuts in.

— How to Install —

□ **Parallel connection of motors**

The FC 300 is able to control several parallel-connected motors. The total current consumption of the motors must not exceed the rated output current I_{INV} for the FC 300.

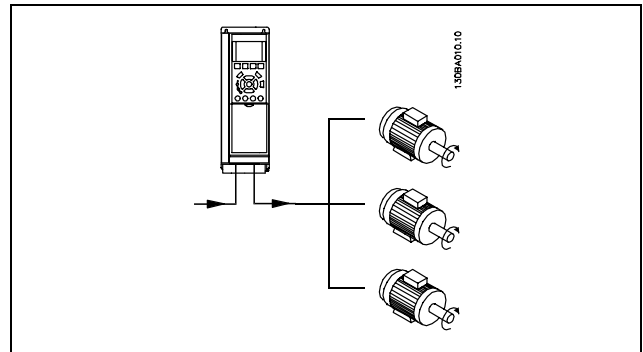

Problems may arise at start and at low RPM values if motor sizes are widely different because small motors' relatively high ohmic resistance in the stator calls for a higher voltage at start and at low RPM values.

The electronic thermal relay (ETR) of the FC 300 cannot be used as motor protection for the individual motor in systems with motors connected in parallel. Further motor protection must be provided, e.g. thermistors in each motor or individual thermal relays. (Circuit breakers are not suitable as protection).



NOTE

When motors are connected in parallel, parameter 1-29 *Automatic motor adaptation (AMA)* cannot be used.

For more information, see *VLT AutomationDrive FC 300 Design Guide*.

□ **Thermal motor protection**

The electronic thermal relay in FC 300 has received the UL-approval for single motor protection, when parameter 1-26 *Motor thermal protection* is set for *ETR Trip* and parameter 1-23 *Motor current*, $I_{M, N}$ is set to the rated motor current (see motor nameplate).

How to Program

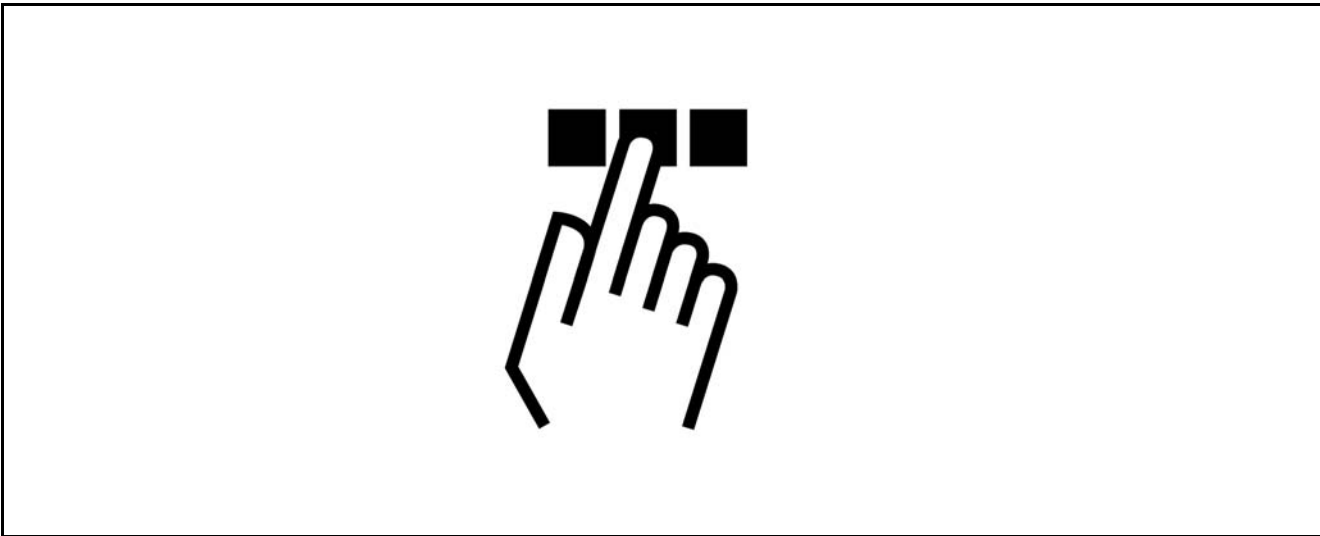

□ **How to Program on the Local Control Panel**

In the following instructions, we assume you have a graphical LCP (LCP 102):

The control panel is divided into four functional groups:

1. Graphical display with Status lines.
2. Menu keys and indicator lights - changing parameters and switching between display functions.
3. Navigation keys and indicator lights (LEDs).
4. Operation keys and indicator lights (LEDs).

All data is displayed in a graphical LCP display, which can show up to five items of operating data while displaying [Status].

Display lines:

- a. **Status line:** Status messages displaying icons and graphic.
- b. **Line 1-2:** Operator data lines displaying data defined or chosen by the user. By pressing the [Status] key, up to one extra line can be added.
- c. **Status line:** Status messages displaying text.

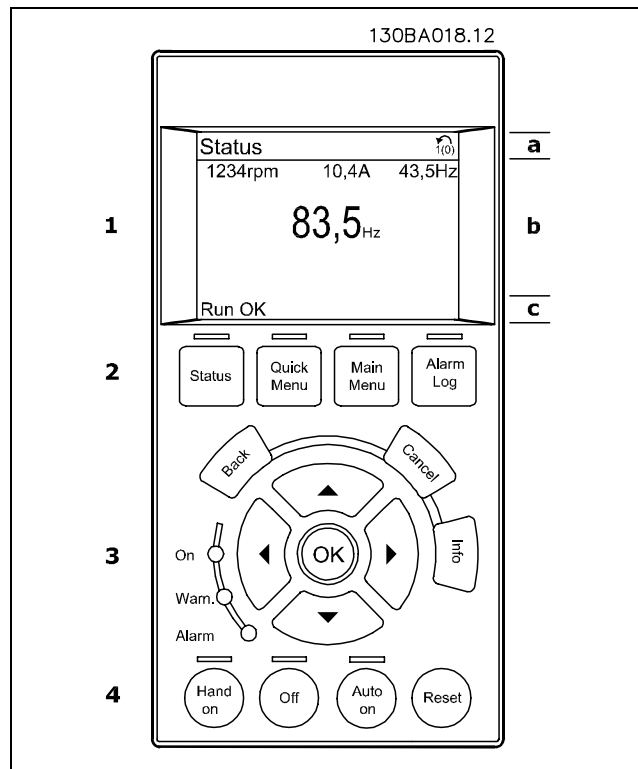

— How to Program —

Indicator lights (LEDs):

- Green LED/On: Indicates if control section is working.
- Yellow LED/Warn.: Indicates a warning.
- Flashing Red LED/Alarm: Indicates an alarm.

Most FC 300 parameter set-ups can be changed immediately via the control panel, unless a password has been created via par. 0-60 *Main Menu Password* or via par. 0-65 *Quick Menu Password*.

LCP keys

[Status] indicates the status of the adjustable frequency drive or the motor. You can choose between 3 different readouts by pressing the [Status] key:
5 line readouts, 4 line readouts or Smart Logic Controller.

[Quick Menu] allows quick access to different Quick Menus such as:

- My Personal Menu
- Quick Set-up
- Changes Made
- Loggings

[Main Menu] is used for programming all parameters.

[Alarm Log] displays an Alarm list of the five latest alarms (numbered A1-A5). To obtain additional details about an alarm, use the arrow keys to maneuver to the alarm number and press [OK]. You will now receive information about the condition of your adjustable frequency drive right before entering the alarm mode.

[Back] takes you to the previous step or layer in the navigation structure.

[Cancel] annuls your last change or command as long as the display has not been changed.

[Info] supplies information about a command, parameter, or function in any display window. Exit info mode by pressing either [Info], [Back], or [Cancel].

[OK] is used for choosing a parameter marked by the cursor and for confirming the change of a parameter.

[Hand On] enables control of the adjustable frequency drive via the LCP. [Hand on] also starts the motor, and it is now possible to enter the motor speed data by means of the arrow keys. The key can be selected as Enable [1] or Disable [0] via par. 0-40 *[Hand on] key on LCP*.

External stop signals activated by means of control signals or a serial bus will override a "start" command given via the LCP.

[Off] is used for stopping the connected motor. The key can be selected as Enable [1] or Disable [0] via par. 0-41 *[Off] key on LCP*.

[Auto On] is used if the adjustable frequency drive is to be controlled via the control terminals and/or serial communication. When a start signal is active on the control terminals and/or the bus, the adjustable frequency drive will start. The key can be selected as Enable [1] or Disable [0] via par. 0-42 *[Auto on] key on LCP*.

[Reset] is used for resetting the adjustable frequency drive after an alarm (trip). It can be selected as *Enable* [1] or *Disable* [0] via par. 0-43 *Reset Keys on LCP*.

Arrow keys are used for maneuvering between commands and within parameters.

— How to Program —

The **parameter shortcut** can be carried out by holding down the [Main Menu] key for 3 seconds. The parameter shortcut allows direct access to any parameter.

□ **Quick Transfer of Parameter Settings**

Once the setup of a drive is complete, we recommend that you store the data in the LCP or on a PC via MCT 10 Setup Software Tool.

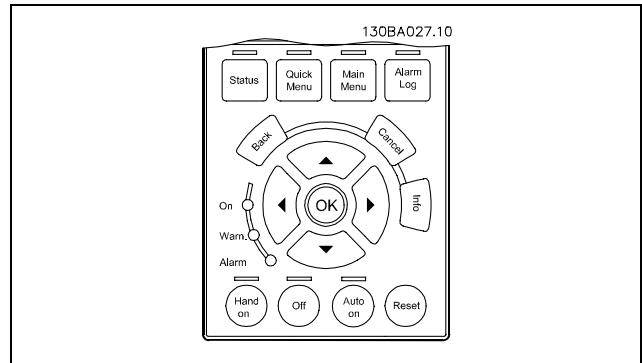

Data storage in LCP:

1. Go to par. 0-50 LCP copy
2. Press the [OK] key
3. Select "All to LCP"
4. Press the [OK] key

All parameter settings are now stored in the LCP indicated by the progress bar. When 100% is reached, press [OK].



NOTE

Stop the unit before performing this operation.

You can now connect the LCP to another adjustable frequency drive and copy the parameter settings to this adjustable frequency drive as well.

Data transfer from LCP to drive:

1. Go to par. 0-50 LCP copy
2. Press the [OK] key
3. Select "All from LCP"
4. Press the [OK] key

The parameter settings stored in the LCP are now transferred to the drive indicated by the progress bar. When 100% is reached, press [OK].



NOTE

Stop the unit before performing this operation.

□ **Reset to Default Setting**

To restore all parameter values to their default setting, go to par. 14-22 *Operating Mode* and select Initialization. Power down the adjustable frequency drive. The adjustable frequency drive will automatically restore to default settings during the next power-up.



— How to Program —

□ **Adjust Display Contrast**

Hold down [STATUS] and use the up or down navigation arrow to adjust the display contrast

□ **How to Connect a PC to the FC 300**

To control the adjustable frequency drive from a PC, install the MCT 10 Setup Software. The PC is connected via a standard (host/device) USB cable, or via the RS-485 interface as shown in the section *Bus Connection* in the chapter *How to Program*.

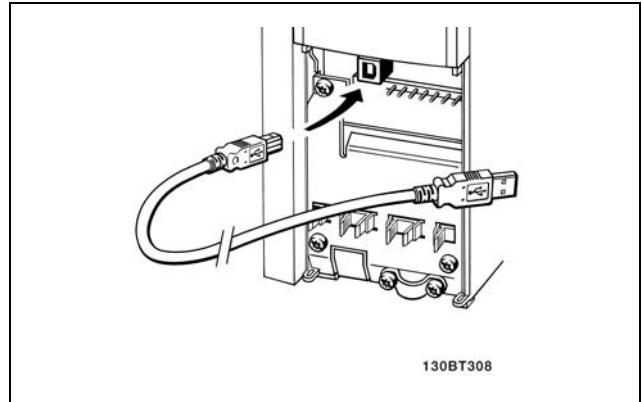

USB connection.

□ **The FC 300 Software Dialog**

Data storage in PC via MCT 10 Set-Up Software:

1. Connect a PC to the unit via USB com port
2. MCT 10 Set-up Software
3. Choose "Read from drive"
4. Choose "Save as"

All parameters are now stored.

Data transfer from PC to drive via MCT 10 Set-Up Software:

1. Connect a PC to the unit via USB com port
2. MCT 10 Set-up Software
3. Choose "Open" - stored files will be shown
4. Open the appropriate file
5. Choose "Write to drive"

All parameters are now transferred to the drive.

A separate manual for MCT 10 Set-up Software is available.



— How to Program —

□ **Connection Examples**

□ **Start/stop**

Terminal 18 = start/stop
 Terminal 37 = coasting stop (safe)
 Terminal 27 = coast inverse

Par. 5 Digital input = Pulse start -10
 Par. 5-12 Digital input = coast inverse(default)

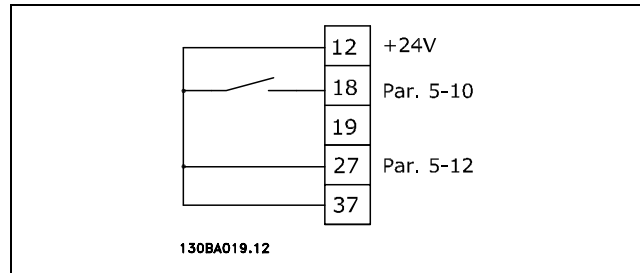

□ **Pulse start/stop**

Terminal 18 = latched start
 Terminal 27 = stop inverse

Par. 5 Digital input = Pulse start -10
 Par. 5 Digital input = Stop inverted -12

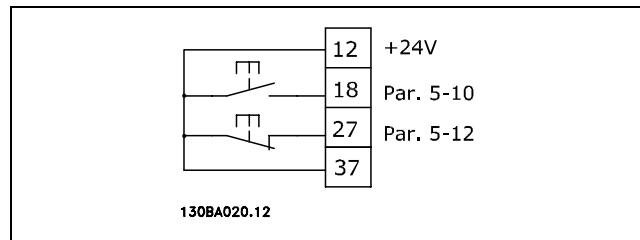

□ **Speed up/slow down**

Terminals 29/32 = Speed up/slow down.

Par. 5 Digital input = Pulse start -10
 Par. 5 Digital input = Freeze reference -12
 Par. 5 Digital input = Speed up -13
 Par. 5-14 Digital input = Slow down

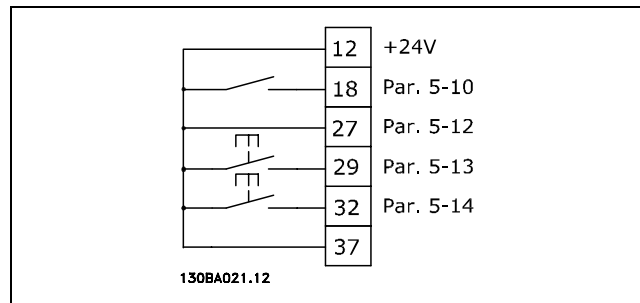

□ **Potentiometer reference**

Voltage reference via a potentiometer.

Par. 3-15 Reference resource 1 = Analog input 53 (default)
 Par. 6-10 Terminal 53, low voltage = 0 Volt (default)
 Par. 6-11 Terminal 53, high voltage = 10 Volt (default)
 Par. 6-14 Terminal 53, low ref./feedb. value = 0 RPM (default)
 Par. 6-15 Terminal 53, high ref./feedb. value = 1.500 RPM
 Switch S201 = OFF (U)

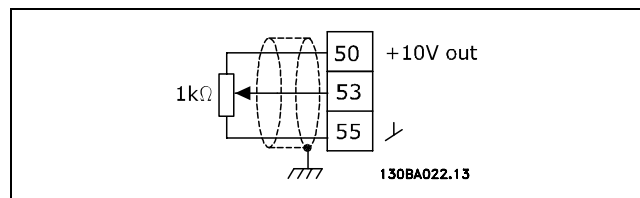

— How to Program —

□ **Basic Parameters**

0-01 Language

Option:

- *English (ENGLISH) [0]
- German (DEUTSCH) [1]
- French (FRANCAIS) [2]
- Danish (DANSK) [3]
- Spanish (ESPAÑOL) [4]
- Italian (ITALIANO) [5]
- Chinese (CHINESE) [10]

Function:

Choose the desired LCP language.

1-20 Motor Power [HP]

Range:

0.50 - 10 HP (0.37-7.5 kW) [Motor type dependent]

Function:

The value should equal the nameplate data on the connected motor. The default value corresponds to the nominal rated output of the unit.

 **NOTE**
Changing the value in this parameter affects the setting of other parameters. Par. 1-20 cannot be changed while the motor is running.

1-22 Motor Voltage

Range:

200-500 V [Motor type dependent]

Function:

The value should equal the nameplate data on the connected motor. The default value corresponds to the nominal rated output of the unit.

 **NOTE**
Changing the value in this parameter affects the setting of other parameters. Par. 1-22 cannot be changed while the motor is running.

1-23 Motor frequency

Option:

- *50 Hz (50 HZ) [50]
- 60 Hz (60 HZ) [60]
- Min - Max motor frequency: 20 - 300 Hz

Function:

Select the stated value from the motor name plate. Alternatively, set the value for motor frequency to be infinitely variable. If a value different from 50 Hz or 60 Hz is selected, it is necessary to correct par. 1-50 to 1-54. For 87 Hz operation with 230/400 V motors, set the name plate data for 230 V/50 Hz. Adapt par. 2-02 *Output speed high limit* and par. 2-05 *Maximum reference* to the 87 Hz application.

 **NOTE**
Changing the value in this parameter affects the setting of other parameters. Par. 1-23 cannot be changed while the motor is running.

 **NOTE**
If a delta connection is used, select the rated motor frequency for the delta connection.

1-24 Motor current

Range:

Motor type dependent.

Function:

The value should equal the nameplate data on the connected motor. Data is used for calculating torque, motor protection, etc.

 **NOTE**
Changing the value in this parameter affects the setting of other parameters. Par. 1-24 cannot be changed while the motor is running.

1-25 Motor nominal speed

Range:

100 - 60000 RPM * RPM

Function:

The value should equal the name plate data on the connected motor. The data is used for calculating motor compensations.

* default setting () display text [] value for use in communication via serial communication port

— How to Program —

1-29 Automatic Motor Adaptation, (AMA)

Option:

- *OFF [0]
- Enable complete AMA [1]
- Enable reduced AMA [2]

Function:

If the AMA function is used, the adjustable frequency drive automatically sets the necessary control parameters (par. 1-30 to par. 1-35) with the motor stationary. AMA ensures optimum use of the motor. For the best possible adaptation of the adjustable frequency drive, run AMA on a cold motor. Select *Enable complete AMA*, if the adjustable frequency drive is to carry out AMA of the stator resistance R_s , the rotor resistance R_r , the stator leakage reactance x_1 , the rotor leakage reactance X_2 and the main reactance X_h . Select *Reduced AMA* if a reduced test is to be carried out, in which only the stator resistance R_s in the system is determined. AMA cannot be carried out while the motor is running.

Activate the AMA function by pressing [Hand on] after selecting [1] or [2]. See also section *Automatic Motor Adaptation*. After a normal sequence, the display will read, "Press [OK] to finish AMA." After pressing the [OK] key, the adjustable frequency drive is now ready for operation.



NOTE

It is important to set motor par. 1-2* correctly, since these form part of the AMA algorithm. For optimum dynamic motor adaptation, an AMA must be carried out. It may take up to 10 min, depending on the power rating of the motor.



NOTE

Avoid externally generating torque during AMA.



NOTE

If one of the settings in par. 1-2* is changed, par. 1-30 to 1-39 will return to default setting.

3-02 Minimum reference

Option:

- 100000.000 - MaxReference (par. 3-03)
- *0.000

Function:

The *Minimum reference* is the minimum value obtained by the sum of all references. *Minimum reference* is only active if Min - Max [0] is set in par. 3-00. Speed control, closed loop: RPM Torque control Speed feedback: Nm

3-03 Maximum reference

Option:

- MinReference (par. 3-02) - 100000.000
- *1500.000

Function:

The *Maximum reference* is the highest value obtained by the sum of all references. The unit follows the choice of configuration in par. 1-00. Speed control, closed loop: RPM Torque control, speed feedback: Nm

3-41 Ramp 1 ramp up time

Range:

- 0.01 - 3600.00 s
- *ExpressionLimit s

Function:

The ramp-up time is the acceleration time from 0 RPM to the rated motor speed $n_{M,N}$ (par. 1-23), provided that the output current does not reach the torque limit (set in par. 4-16). The value 0.00 corresponds to 0.01 s in speed mode.

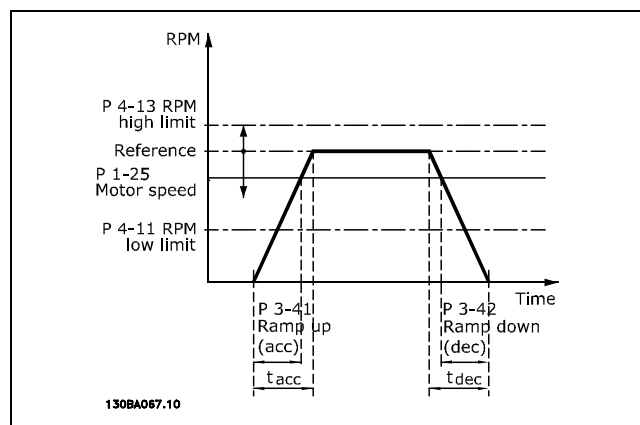

$$Par. 3 - 41 = \frac{t_{acc} * n_{norm} [par. 1 - 25]}{\Delta ref [RPM]} [s]$$

* default setting () display text [] value for use in communication via serial communication port

— How to Program —

3-42 Ramp 1 ramp-down time**Range:**

0.01 - 3600.00 s *ExpressionLimit s

Function:

The ramp-down time is the deceleration time from the rated motor speed $n_{M,N}$ (par. 1-23) to 0 RPM, provided that there is no over-voltage in the inverter due to regenerative operation of the motor, or if the generated current reaches the torque limit (set in par. 4-17). The value 0.00 corresponds to 0.01 s in speed mode. See ramp-up time in par. 3-41

$$Par. 3 - 42 = \frac{t_{acc} * n_{norm} [par. 1 - 25]}{\Delta ref [RPM]} [s]$$



* default setting () display text [] value for use in communication via serial communication port

— How to Program —

Parameter lists

Changes during operation

"TRUE" means that the parameter can be changed while the adjustable frequency drive is in operation and "FALSE" means that the it must be stopped before a change can be made.

4-Set-up

'All set-up': the parameters can be set individually in each of the four set-ups, i.e. one single parameter can have four different data values.

'1 set-up': data value will be the same in all set-ups.

Conversion index

This number refers to a conversion figure used when writing or reading by means of a variable frequency drive.

Conv. index	100	67	6	5	4	3	2	1	0	-1	-2	-3	-4	-5	-6
Conv. factor	1	1/60	1000000	100000	10000	1000	100	10	1	0.1	0.01	0.001	0.0001	0.00001	0.000001

Data type	Description	Type
2	Integer 8	Int8
3	Integer 16	Int16
4	Integer 32	Int32
5	Unsigned 8	Uint8
6	Unsigned 16	Uint16
7	Unsigned 32	Uint32
9	Visible String	VisStr
33	Normalized value 2 bytes	N2
35	Bit sequence of 16 boolean variables	V2
54	Time difference w/o date	TimD

See the *FC 300 Design Guide* for further information about data types 33, 35 and 54.



* default setting () display text [] value for use in communication via serial communication port

— How to Program —

□ **0-** Operation/Display**

Par. No. #	Parameter description	Default value	4-set-up	Change during operation	Conversion index	Type
0-0* Basic settings						
0-01	Language	[0] English	1 set-up	TRUE	-	Uint8
0-04	Operating state at Power-up (Hand)	[1] Forced stop, ref=old	All set-ups	TRUE	-	Uint8
0-1* Set-up handling						
0-10	Active set-up	[1] Setup 1	1 set-up	TRUE	-	Uint8
0-11	Edit set-up	[1] Setup 1	All set-ups	TRUE	-	Uint8
0-12	This set-up linked to	[1] Setup 1	All set-ups	FALSE	-	Uint8
0-13	Readout: Linked set-ups	0	All set-ups	FALSE	0	Uint16
0-14	Readout: Edit set-ups / channel	0	All set-ups	TRUE	0	Uint32
0-2* LCP Display						
0-20	Display line 1.1 small	[1617] Speed (RPM)	All set-ups	TRUE	-	Uint16
0-21	Display line 1.2 small	[1614] Motor current	All set-ups	TRUE	-	Uint16
0-22	Display line 1.3 small	[1610] Power (kW)	All set-ups	TRUE	-	Uint16
0-23	Display line 2 large	[1613] Frequency	All set-ups	TRUE	-	Uint16
0-24	Display line 3 large	[1602] Reference %	All set-ups	TRUE	-	Uint16
0-25	My personal menu	User dependent	1 set-up	TRUE	0	Uint16
0-4* LCP keypad						
0-40	[Hand on] key on LCP	[1] Enabled	All set-ups	TRUE	-	Uint8
0-41	[Off] key on LCP	[1] Enabled	All set-ups	TRUE	-	Uint8
0-42	[Auto on] key on LCP	[1] Enabled	All set-ups	TRUE	-	Uint8
0-43	[Reset] key on LCP	[1] Enabled	All set-ups	TRUE	-	Uint8
0-5* Copy/Save						
0-50	LCP copy	[0] No copy	All set-ups	FALSE	-	Uint8
0-51	Set-up copy	[0] No copy	All set-ups	FALSE	-	Uint8
0-6* Password						
0-60	Main menu password	100	1 set-up	TRUE	0	Uint16
0-62	Access to main menu w/o password	[0] Full access	1 set-up	TRUE	-	Uint8
0-64	Quick menu password	200	1 set-up	TRUE	0	Uint16
0-66	Access to quick menu w/o password	[0] Full access	1 set-up	TRUE	-	Uint8

* default setting () display text [] value for use in communication via serial communication port

— How to Program —

□ **1-** Load/Motor**

Par. No. #	Parameter description	Default value	4-set-up	Change during operation	Conversion index	Type
1-0* General settings						
1-00	Configuration mode	[0] Speed open loop	All set-ups	FALSE	-	Uint8
1-01	Motor control principle	[1] VVCplus	All set-ups	FALSE	-	Uint8
1-2* Motor data						
1-20	Motor power [HP]	Drive dependent	All set-ups	FALSE	1	Uint32
1-22	Motor voltage	Drive dependent	All set-ups	FALSE	0	Uint16
1-23	Motor frequency	Drive dependent	All set-ups	FALSE	0	Uint16
1-24	Motor current	Drive dependent	All set-ups	FALSE	-2	Uint16
1-25	Motor nominal speed	Drive dependent	All set-ups	FALSE	67	Uint16
1-29	Automatic motor adaptation(AMA)	[0] Off	All set-ups	FALSE	-	Uint8
1-3* Advanced motor data						
1-30	Stator resistance (Rs)	Motor dependent	All set-ups	FALSE	-4	Uint32
1-31	Rotor resistance (Rr)	Motor dependent	All set-ups	FALSE	-4	Uint32
1-33	Stator leakage reactance (X1)	Motor dependent	All set-ups	FALSE	-4	Uint32
1-34	Rotor leakage reactance (X2)	Motor dependent	All set-ups	FALSE	-4	Uint32
1-35	Main reactance (Xh)	Motor dependent	All set-ups	FALSE	-4	Uint32
1-36	Iron loss resistance (Rfe)	Motor dependent	All set-ups	FALSE	-3	Uint32
1-39	Motor poles	Motor dependent	All set-ups	FALSE	0	Uint8
1-4* Motor temperature						
1-40	Motor thermal protection	[0] No protection	All set-ups	TRUE	-	Uint8
1-41	Motor external fan	[0] No	All set-ups	TRUE	-	Uint16
1-43	Thermistor source	[0] None	All set-ups	FALSE	-	Uint8
1-5* Load indep. setting						
1-50	Motor magnetizing at zero speed	100 %	All set-ups	TRUE	0	Uint16
1-51	Min speed normal magnetizing [RPM]	1 RPM	All set-ups	TRUE	67	Uint8
1-6* Load depen. setting						
1-60	Low speed load compensation	100 %	All set-ups	TRUE	0	Int16
1-61	High speed load compensation	100 %	All set-ups	TRUE	0	Int16
1-62	Slip compensation	100 %	All set-ups	TRUE	0	Int16
1-63	Slip compensation time constant	0.10 s	All set-ups	TRUE	-2	Uint16
1-64	Resonance dampening	100 %	All set-ups	TRUE	0	Uint16
1-65	Resonance dampening time constant	5 ms	All set-ups	TRUE	-3	Uint8
1-66	Min. current at low speed	100 %	All set-ups	TRUE	0	Uint8
1-67	Load type	[0] Passive load	All set-ups	TRUE	-	Uint8
1-68	Minimum inertia	Drive dependent	All set-ups	FALSE	-4	Uint32
1-69	Maximum inertia	Drive dependent	All set-ups	FALSE	-4	Uint32
1-7* Start adjustments						
1-71	Start delay	0.0 s	All set-ups	TRUE	-1	Uint8
1-72	Start function	[2] Coast/delay time	All set-ups	TRUE	-	Uint8
1-74	Start speed [RPM]	0 RPM	All set-ups	TRUE	67	Uint16
1-76	Start current	0.00 A	All set-ups	TRUE	-2	Uint16
1-8* Stop adjustments						
1-80	Function at stop	[0] Coast	All set-ups	TRUE	-	Uint8
1-81	Min speed for function at stop [RPM]	0 RPM	All set-ups	TRUE	67	Uint16

* default setting () display text [] value for use in communication via serial communication port



— How to Program —

□ **2-** Brakes**

Par. No. #	Parameter description	Default value	4-set-up	Change during operation	Conversion index	Type
2-0* DC-brake						
2-00	DC hold current	50 %	All set-ups	TRUE	0	Uint8
2-01	DC brake current	50 %	All set-ups	TRUE	0	Uint16
2-02	DC braking time	10.0 s	All set-ups	TRUE	-1	Uint16
2-03	DC brake cut-in speed	0 RPM	All set-ups	TRUE	67	Uint16
2-1* Brake energy funct.						
2-10	Brake and over-voltage functions	[0] Off	All set-ups	TRUE	-	Uint8
2-11	Brake resistor (ohm)	Drive dependent	All set-ups	TRUE	0	Uint16
2-12	Brake power limit (kW)	Drive dependent	All set-ups	TRUE	0	Uint32
2-13	Brake power monitoring	[0] Off	All set-ups	TRUE	-	Uint8
2-15	Brake check	[0] Off	All set-ups	TRUE	-	Uint8
2-2* Mechanical brake						
2-20	Release brake current	0.00 A	All set-ups	TRUE	-2	Uint16
2-21	Activate brake speed [RPM]	0 RPM	All set-ups	TRUE	67	Uint16
2-23	Activate brake delay	0.0 s	All set-ups	TRUE	-1	Uint8



* default setting () display text [] value for use in communication via serial communication port

— How to Program —

□ **3-** Reference / Ramps**

Par. No. #	Parameter description	Default value	4-set-up	Change during operation	Conversion index	Type
3-0* Reference limits						
3-00	Reference range	[0] Min - Max	All set-ups	TRUE	-	Uint8
3-03	Maximum reference	1500.000 Unit	All set-ups	TRUE	-3	Int32
3-1* References						
3-10	Preset reference	0.00 %	All set-ups	TRUE	-2	Int16
3-12	Catch up/slow down value	0.00 %	All set-ups	TRUE	-2	Int16
3-13	Reference site	[0] Linked to Hand / Auto	All set-ups	FALSE	-	Uint8
3-14	Preset relative reference	0.00 %	All set-ups	TRUE	-2	Int32
3-15	Reference resource 1	[1] Analog input 53	All set-ups	FALSE	-	Uint8
3-16	Reference resource 2	[2] Analog input 54	All set-ups	FALSE	-	Uint8
3-17	Reference resource 3	[11] Local bus reference	All set-ups	FALSE	-	Uint8
3-18	Relative scaling reference resource	[0] No function	All set-ups	FALSE	-	Uint8
3-19	Jog speed	25 RPM	All set-ups	TRUE	67	Uint16
3-4* Ramp 1						
3-40	Ramp 1 type	[0] Linear	All set-ups	TRUE	-	Uint8
3-41	Ramp 1 ramp up time	Drive dependent	All set-ups	TRUE	-2	Uint32
3-42	Ramp 1 ramp down time	Drive dependent	All set-ups	TRUE	-2	Uint32
3-5* Ramp 2						
3-50	Ramp 2 type	[0] Linear	All set-ups	TRUE	-	Uint8
3-51	Ramp 2 ramp up time	Drive dependent	All set-ups	TRUE	-2	Uint32
3-52	Ramp 2 ramp down time	Drive dependent	All set-ups	TRUE	-2	Uint32
3-6* Ramp 3						
3-60	Ramp 3 type	[0] Linear	All set-ups	TRUE	-	Uint8
3-61	Ramp 3 ramp up time	Drive dependent	All set-ups	TRUE	-2	Uint32
3-62	Ramp 3 ramp down time	Drive dependent	All set-ups	TRUE	-2	Uint32
3-7* Ramp 4						
3-70	Ramp 4 type	[0] Linear	All set-ups	TRUE	-	Uint8
3-71	Ramp 4 ramp up time	Drive dependent	All set-ups	TRUE	-2	Uint32
3-72	Ramp 4 ramp down time	Drive dependent	All set-ups	TRUE	-2	Uint32
3-8* Other ramps						
3-80	Jog ramp time	Drive dependent	All set-ups	TRUE	-2	Uint32
3-81	Quick stop ramp time	Drive dependent	1 set-up	TRUE	-2	Uint32
3-9* Digital Pot.Meter						
3-90	Step Size	0.01 %	All set-ups	FALSE	-2	Uint16
3-91	Ramp Time	1.00 s	All set-ups	FALSE	-2	Uint32
3-92	Power Restore	[0] Off	All set-ups	FALSE	-	Uint8
3-93	Limit	100 %	All set-ups	FALSE	0	Uint16



* default setting () display text [] value for use in communication via serial communication port

— How to Program —

□ **4-** Limits / Warnings**

Par. No. #	Parameter description	Default value	4-set-up	Change during operation	Conversion index	Type
4-1* Motor limits						
4-10	Motor speed direction	[2] Both directions	All set-ups	FALSE	-	Uint8
4-11	Motor speed low limit [RPM]	0 RPM	All set-ups	TRUE	67	Uint16
4-13	Motor speed high limit [RPM]	3600 RPM	All set-ups	TRUE	67	Uint16
4-16	Torque limit motor mode	160.0 %	All set-ups	TRUE	-1	Uint16
4-17	Torque limit generator mode	160.0 %	All set-ups	TRUE	-1	Uint16
4-18	Current limit	160.0 %	All set-ups	TRUE	-1	Uint16
4-19	Max output frequency	132.0 Hz	All set-ups	FALSE	-1	Uint16
4-5* Adj. warnings						
4-50	Warning current low	0.00 A	All set-ups	TRUE	-2	Uint16
4-51	Warning current high	Par. 16-37	All set-ups	TRUE	-2	Uint16
4-52	Warning speed low	0 RPM	All set-ups	TRUE	67	Uint16
4-53	Warning speed high	Par. 4-13	All set-ups	TRUE	67	Uint16
4-56	Warning feedback low	0.000 Unit	All set-ups	TRUE	-3	Int32
4-57	Warning feedback high	1500.000 Unit	All set-ups	TRUE	-3	Int32
4-58	Missing motor phase function	[0] Off	All set-ups	FALSE	-	Uint8
4-6* Speed bypass						
4-60	Bypass speed from [RPM]	0 RPM	All set-ups	TRUE	67	Uint16
4-62	Bypass speed to [RPM]	0 RPM	All set-ups	TRUE	67	Uint16



* default setting () display text [] value for use in communication via serial communication port

— How to Program —

□ **5-** Digital In/Out**

Par. No. #	Parameter description	Default value	4-set-up	Change during operation	Conversion index	Type
5-0* Digital IO mode						
5-00	Digital I/O mode	[0] PNP	All set-ups	FALSE	-	Uint8
5-01	Terminal 27 mode	[0] Input	All set-ups	FALSE	-	Uint8
5-02	Terminal 29 mode	[0] Input	All set-ups	FALSE	-	Uint8
5-1* Digital inputs						
5-10	Terminal 18 digital input	[8] Start	All set-ups	TRUE	-	Uint8
5-11	Terminal 19 digital input	[10] Reverse	All set-ups	TRUE	-	Uint8
5-12	Terminal 27 digital input	[2] Coast inverse	All set-ups	TRUE	-	Uint8
5-13	Terminal 29 digital input	[14] Jog	All set-ups	TRUE	-	Uint8
5-14	Terminal 32 digital input	[24] Set-up select bit 1	All set-ups	TRUE	-	Uint8
5-15	Terminal 33 digital input	[23] Set-up select bit 0	All set-ups	TRUE	-	Uint8
5-3* Digital outputs						
5-30	Terminal 27 digital output	[0] No operation	All set-ups	TRUE	-	Uint8
5-31	Terminal 29 digital output	[0] No operation	All set-ups	TRUE	-	Uint8
5-4* Relays						
5-40	Function relay	[0] No operation	All set-ups	TRUE	-	Uint8
5-41	On delay, relay	0.01 s	All set-ups	TRUE	-2	Uint16
5-42	Off delay, relay	0.01 s	All set-ups	TRUE	-2	Uint16
5-5* Pulse input						
5-50	Term. 29 low frequency	100 Hz	All set-ups	TRUE	0	Uint32
5-51	Term. 29 high frequency	100 Hz	All set-ups	TRUE	0	Uint32
5-52	Term. 29 low ref./feedb. value	0.000 Unit	All set-ups	TRUE	-3	Int32
5-53	Term. 29 high ref./feedb. value	1500.000 Unit	All set-ups	TRUE	-3	Int32
5-54	Pulse filter time constant #29	100 ms	All set-ups	FALSE	-3	Uint16
5-55	Term. 33 low frequency	100 Hz	All set-ups	TRUE	0	Uint32
5-56	Term. 33 high frequency	100 Hz	All set-ups	TRUE	0	Uint32
5-57	Term. 33 low ref./feedb. value	0.000 Unit	All set-ups	TRUE	-3	Int32
5-58	Term. 33 high ref./feedb. value	1500.000 Unit	All set-ups	TRUE	-3	Int32
5-59	Pulse filter time constant #33	100 ms	All set-ups	FALSE	-3	Uint16
5-6* Pulse output						
5-60	Terminal 27 pulse output variable	[0] No operation	All set-ups	FALSE	-	Uint8
5-62	Pulse output maximum frequency #27	5000 Hz	All set-ups	FALSE	0	Uint32
5-63	Terminal 29 pulse output variable	[0] No operation	All set-ups	FALSE	-	Uint8
5-65	Pulse output maximum frequency #29	5000 Hz	All set-ups	FALSE	0	Uint32
5-7* 24V encoder input						
5-70	Term 32/33 encoder resolution	1024	All set-ups	FALSE	0	Uint16
5-71	Term 32/33 encoder direction	[0] Clockwise	All set-ups	FALSE	-	Uint8



* default setting () display text [] value for use in communication via serial communication port

— How to Program —

□ **6-** Analog In/Out**

Par. No. #	Parameter description	Default value	4-set-up	Change during operation	Conversion index	Type
6-0* Analog IO mode						
6-00	Live zero Timeout Time	10 s	All set-ups	TRUE	0	Uint8
6-01	Live zero Timeout Function	[0] Off	All set-ups	TRUE	-	Uint8
6-1* Analog input 1						
6-10	Terminal 53 low voltage	0.07 V	All set-ups	TRUE	-2	Int16
6-11	Terminal 53 high voltage	10.00 V	All set-ups	TRUE	-2	Int16
6-12	Terminal 53 low current	0.14 mA	All set-ups	TRUE	-5	Int16
6-13	Terminal 53 high current	20.00 mA	All set-ups	TRUE	-5	Int16
6-14	Terminal 53 low ref./feedb. value	0.000 Unit	All set-ups	TRUE	-3	Int32
6-15	Terminal 53 high ref./feedb. value	1500.000 Unit	All set-ups	TRUE	-3	Int32
6-16	Terminal 53 filter time constant	0.001 s	All set-ups	FALSE	-3	Uint16
6-2* Analog input 2						
6-20	Terminal 54 low voltage	0.07 V	All set-ups	TRUE	-2	Int16
6-21	Terminal 54 high voltage	10.00 V	All set-ups	TRUE	-2	Int16
6-22	Terminal 54 low current	0.14 mA	All set-ups	TRUE	-5	Int16
6-23	Terminal 54 high current	20.00 mA	All set-ups	TRUE	-5	Int16
6-24	Terminal 54 low ref./feedb. value	0.000 Unit	All set-ups	TRUE	-3	Int32
6-25	Terminal 54 high ref./feedb. value	1500.000 Unit	All set-ups	TRUE	-3	Int32
6-26	Terminal 54 filter time constant	0.001 s	All set-ups	FALSE	-3	Uint16
6-5* Analog output 1						
6-50	Terminal 42 output	[0] No operation	All set-ups	TRUE	-	Uint8
6-51	Terminal 42 output min scale	0.00 %	All set-ups	TRUE	-2	Int16
6-52	Terminal 42 output max scale	100.00 %	All set-ups	TRUE	-2	Int16

□ **7-** Controllers**

Par. No. #	Parameter description	Default value	4-set-up	Change during operation	Conversion index	Type
7-0* Speed PID ctrl.						
7-02	Speed PID proportional gain	0.015	All set-ups	TRUE	-3	Uint16
7-03	Speed PID Integral Time	Drive dependent	All set-ups	TRUE	-4	Uint32
7-04	Speed PID differentiation time	Drive dependent	All set-ups	TRUE	-4	Uint16
7-05	Speed PID diff. gain Limit	5.0	All set-ups	TRUE	-1	Uint16
7-06	Speed PID lowpass filter time	10.0 ms	All set-ups	TRUE	-4	Uint16

* default setting () display text [] value for use in communication via serial communication port

— How to Program —

□ **8-** Comm. and options**

Par. No. #	Parameter description	Default value	4-set-up	Change during operation	Conversion index	Type
8-0* General settings						
8-00	Enabled options	[1] All	All set-ups	FALSE	-	Uint8
8-01	Control site	[0] Digital and ctrl.word	All set-ups	TRUE	-	Uint8
8-02	Controlword source	[0] FC RS485	All set-ups	TRUE	-	Uint8
8-03	Controlword Timeout Time	1.0 s	1 set-up	TRUE	-1	Uint32
8-04	Controlword Timeout Function	[0] Off	1 set-up	FALSE	-	Uint8
8-05	End-of-timeout function	[1] Resume set-up	1 set-up	TRUE	-	Uint8
8-06	Reset Controlword Timeout	[0] Do not reset	All set-ups	TRUE	-	Uint8
8-07	Diagnosis trigger	[0] Disable	2 set-ups	FALSE	-	Uint8
8-1* Ctrl. word settings						
8-10	Control word profile	[0] FC profile	All set-ups	TRUE	-	Uint8
8-3* FC Port settings						
8-30	Protocol	[0] FC	1 set-up	FALSE	-	Uint8
8-31	Address	1	1 set-up	FALSE	0	Uint8
8-32	FC port baudrate	[2] 9600 Baud	1 set-up	FALSE	-	Uint8
8-35	Minimum response delay	10 ms	All set-ups	FALSE	-3	Uint16
8-36	Max response delay	5000 ms	1 set-up	FALSE	-3	Uint16
8-37	Max inter-char delay	25 ms	1 set-up	FALSE	-3	Uint16
8-5* Digital/Bus						
8-50	Coasting select	[3] Logic OR	All set-ups	TRUE	-	Uint8
8-51	Quick stop select	[3] Logic OR	All set-ups	TRUE	-	Uint8
8-52	DC Brake select	[3] Logic OR	All set-ups	TRUE	-	Uint8
8-53	Start select	[3] Logic OR	All set-ups	TRUE	-	Uint8
8-54	Reverse select	[3] Logic OR	All set-ups	TRUE	-	Uint8
8-55	Set-up select	[3] Logic OR	All set-ups	TRUE	-	Uint8
8-56	Preset reference select	[3] Logic OR	All set-ups	TRUE	-	Uint8
8-9* Bus jog						
8-90	Bus Jog 1 Speed	100 RPM	All set-ups	TRUE	67	Uint16
8-91	Bus Jog 2 Speed	200 RPM	All set-ups	TRUE	67	Uint16



* default setting () display text [] value for use in communication via serial communication port

— How to Program —

□ 9-** Profibus

Par. No. #	Parameter description	Default value	4-set-up	Change during operation	Conversion index	Type
9-00	Setpoint	0	All setups	TRUE	0	Uint16
9-07	Actual Value	0	All setups	FALSE	0	Uint16
9-15	PCD write configuration	0	1 setup	TRUE	-	Uint16
9-16	PCD read configuration	0	1 setup	TRUE	-	Uint16
9-18	Node address	126	1 setup	TRUE	0	Uint8
9-22	Telegram selection	[1] Standard telegram 1	1 setup	TRUE	-	Uint8
9-23	Parameters for signals	0	All setups	TRUE	-	Uint16
9-27	Parameter edit	[1] Enabled	1 setup	FALSE	-	Uint16
9-28	Process control	[1] Enable cyclic master	1 setup	FALSE	-	Uint8
9-53	Profibus Warning Word	0	All setups	TRUE	0	V2
9-63	Actual baud rate	[255] No baud rate found	All setups	TRUE	-	Uint8
9-64	Device Identification	0	All setups	TRUE	0	Uint16
9-65	Profile number	0	All setups	TRUE	0	Uint8
9-67	Control word 1	0	All setups	TRUE	0	V2
9-68	Status word 1	0	All setups	TRUE	0	V2
9-71	Save Data Values	[0] Off	All setups	TRUE	-	Uint8
9-72	Drive Reset	[0] No action	1 setup	FALSE	-	Uint8
9-80	Defined parameters (1)	0	All setups	FALSE	0	Uint16
9-81	Defined parameters (2)	0	All setups	FALSE	0	Uint16
9-82	Defined parameters (3)	0	All setups	FALSE	0	Uint16
9-83	Defined parameters (4)	0	All setups	FALSE	0	Uint16
9-90	Changed parameters (1)	0	All setups	FALSE	0	Uint16
9-91	Changed parameters (2)	0	All setups	FALSE	0	Uint16
9-92	Changed parameters (3)	0	All setups	FALSE	0	Uint16
9-93	Changed parameters (4)	0	All setups	FALSE	0	Uint16

* default setting () display text [] value for use in communication via serial communication port

— How to Program —

□ **10-** CAN fieldbus**

Par. No. #	Parameter description	Default value	4-set-up	Change during operation	Conversion index	Type
10-0* Common settings						
10-00	CAN protocol	[1] Device Net	All set-ups	FALSE	-	Uint8
10-01	Baudrate select	[20] 125 Kbps	All set-ups	FALSE	-	Uint8
10-02	MAC ID	63	All set-ups	FALSE	0	Uint8
10-05	Readout Transmit Error Counter	0	All set-ups	TRUE	0	Uint8
10-06	Readout Receive Error Counter	0	All set-ups	TRUE	0	Uint8
10-07	Readout Bus Off Counter	0	All set-ups	TRUE	0	Uint16
10-1* DeviceNet						
10-10	Process data type selection	App. dependent	1 set-up	TRUE	-	Uint8
10-11	Process Data Config Write	0	All set-ups	FALSE	0	Uint8
10-12	Process Data Config Read	0	All set-ups	FALSE	0	Uint8
10-13	Warning Parameter	63	All set-ups	FALSE	0	Uint8
10-14	Net Reference	[0] Off	All set-ups	TRUE	-	Uint8
10-15	Net Control	[0] Off	All set-ups	TRUE	-	Uint8
10-2* COS filters						
10-20	COS Filter 1	65535	All set-ups	FALSE	0	Uint16
10-21	COS Filter 2	65535	All set-ups	FALSE	0	Uint16
10-22	COS Filter 3	65535	All set-ups	FALSE	0	Uint16
10-23	COS Filter 4	65535	All set-ups	FALSE	0	Uint16
10-3* Parameter access						
10-30	Parameter Data Types	[0] Errata 1	All set-ups	TRUE	-	Uint8
10-31	Array index	0	All set-ups	TRUE	0	Uint16
10-39	Devicenet F parameters	0	All set-ups	TRUE	0	Uint32

□ **13-** Smart logic control**

Par. No. #	Parameter description	Default value	4-set-up	Change during operation	Conversion index	Type
13-1* Comparators						
13-10	Comparator Operand	[0] DISABLED	2 set-ups	FALSE	-	Uint8
13-11	Comparator Operator	[1] ≈	2 set-ups	FALSE	-	Uint8
13-12	Comparator Value	0.000	2 set-ups	FALSE	-3	Int32
13-2* Timers						
13-20	SL control timer	0.000 s	1 set-up	FALSE	-3	TimD
13-4* Logic rules						
13-40	Logic Rule Boolean 1	[0] False	2 set-ups	FALSE	-	Uint8
13-41	Logic Rule Operator 1	[0] DISABLED	2 set-ups	FALSE	-	Uint8
13-42	Logic Rule Boolean 2	[0] False	2 set-ups	FALSE	-	Uint8
13-43	Logic Rule Operator 2	[0] DISABLED	2 set-ups	FALSE	-	Uint8
13-44	Logic Rule Boolean 3	[0] False	2 set-ups	FALSE	-	Uint8
13-5* Smart logic ctrl.						
13-50	SL control mode	[0] Off	2 set-ups	FALSE	-	Uint8
13-51	SL control event	[0] False	2 set-ups	FALSE	-	Uint8
13-52	SL control action	[0] DISABLED	2 set-ups	FALSE	-	Uint8

* default setting () display text [] value for use in communication via serial communication port



— How to Program —

□ **14-*** Special functions**

Par. No. #	Parameter description	Default value	4-set-up	Change during operation	Conversion index	Type
14-0* Inverter switching						
14-00	Switching Pattern	[1] SFAVM	All set-ups	FALSE	-	Uint8
14-01	Switching Frequency	[5] 5.0 kHz	All set-ups	FALSE	-	Uint8
14-03	Overmodulation	[0] Off	All set-ups	FALSE	-	Uint8
14-04	PWM random	[0] Off	All set-ups	FALSE	-	Uint8
14-1* Electrical power On/Off						
14-10	Electrical failure	[0] No function	All set-ups	FALSE	-	Uint8
14-11	Electrical Voltage at Electrical Fault	342 V	All set-ups	TRUE	0	Uint16
14-12	Function at Electrical Imbalance	[0] Trip	All set-ups	TRUE	-	Uint8
14-2* Trip reset						
14-20	Reset mode	[0] Manual reset	All set-ups	TRUE	-	Uint8
14-21	Automatic restart time	10 s	All set-ups	TRUE	0	Uint16
14-22	Operation mode	[0] Normal operation	All set-ups	TRUE	-	Uint8
14-25	Trip delay at torque limit	60 s = Off	All set-ups	FALSE	0	Uint8
14-29	Service code	0	All set-ups	FALSE	0	Int32
14-3* Current limit ctrl.						
14-30	Current lim cont, Proportional Gain	100 %	All set-ups	FALSE	0	Uint16
14-31	Current lim contr, Integration Time	0.020 s	All set-ups	FALSE	-3	Uint16
14-5* Environment						
14-50	RFI 1	[1] On	1 set-up	FALSE	-	Uint8



* default setting () display text [] value for use in communication via serial communication port

— How to Program —

□ **15-** Drive information**

Par. No. #	Parameter description	Default value	4-set-up	Change during operation	Conversion index	Type
15-0* Operating Data						
15-00	Operating hours	0 h	All set-ups	FALSE	74	Uint32
15-01	Running hours	0 h	All set-ups	FALSE	74	Uint32
15-02	kWh counter	0. kWh	All set-ups	FALSE	75	Uint32
15-03	Power up's	0	All set-ups	FALSE	0	Uint32
15-04	Over temp's	0	All set-ups	FALSE	0	Uint16
15-05	Over volt's	0	All set-ups	FALSE	0	Uint16
15-06	Reset of kWh counter	[0] Do not reset	All set-ups	FALSE	-	Uint8
15-07	Reset running hours counter	[0] Do not reset	All set-ups	FALSE	-	Uint8
15-2* Historic Log						
15-20	Historic log: Event	0	All set-ups	FALSE	0	Uint8
15-21	Historic log: Value	0	All set-ups	FALSE	0	Uint32
15-22	Historic log: Time	0 ms	All set-ups	FALSE	-3	Uint32
15-3* Fault Log						
15-30	Fault log: Error code	0	All set-ups	FALSE	0	Uint8
15-31	Fault log: Value	0	All set-ups	FALSE	0	Int16
15-32	Fault log: Time	0 s	All set-ups	FALSE	0	Uint32
15-4* Drive identification						
15-40	FC type	0	All set-ups	FALSE	0	VisStr[6]
15-41	Power section	0	All set-ups	FALSE	0	VisStr[20]
15-42	Voltage	0	All set-ups	FALSE	0	VisStr[20]
15-43	Software version	0	All set-ups	FALSE	0	VisStr[5]
15-44	Ordered typecode string	0	All set-ups	FALSE	0	VisStr[40]
15-45	Actual typecode string	0	All set-ups	FALSE	0	VisStr[40]
15-46	Drive ordering no	0	All set-ups	FALSE	0	VisStr[8]
15-47	Power card ordering no	0	All set-ups	FALSE	0	VisStr[8]
15-48	LCP Id no	0	All set-ups	FALSE	0	VisStr[20]
15-49	SW id control card	0	All set-ups	FALSE	0	VisStr[20]
15-50	SW id power card	0	All set-ups	FALSE	0	VisStr[20]
15-51	Drive serial number	0	All set-ups	FALSE	0	VisStr[10]
15-53	Power card serial number	0	All set-ups	FALSE	0	VisStr[19]
15-6* Option ident						
15-60	Option in slot A	0	All set-ups	FALSE	0	VisStr[30]
15-61	Slot A option SWversion	0	All set-ups	FALSE	0	VisStr[20]
15-62	Slot A ordering no	0	All set-ups	FALSE	0	VisStr[8]
15-63	Slot A option serial number	0	All set-ups	FALSE	0	VisStr[10]
15-65	Option in slot B	0	All set-ups	FALSE	0	VisStr[30]
15-66	Slot B option SWversion	0	All set-ups	FALSE	0	VisStr[20]
15-67	Slot B ordering no	0	All set-ups	FALSE	0	VisStr[8]
15-68	Slot B option serial number	0	All set-ups	FALSE	0	VisStr[10]
15-70	Option in slot C	0	All set-ups	FALSE	0	VisStr[30]
15-71	Slot C option SWversion	0	All set-ups	FALSE	0	VisStr[20]
15-72	Slot C ordering no	0	All set-ups	FALSE	0	VisStr[8]
15-73	Slot C option serial number	0	All set-ups	FALSE	0	VisStr[10]
15-75	Option in slot D	0	All set-ups	FALSE	0	VisStr[30]
15-9* Parameter info						
15-92	Defined parameters	0	All set-ups	FALSE	0	Uint16
15-93	Modified parameters	0	All set-ups	FALSE	0	Uint16
15-99	Parameter metadata	0	All set-ups	FALSE	0	Uint16



* default setting () display text [] value for use in communication via serial communication port

— How to Program —

□ 16-** Data readouts

Par. No. #	Parameter description	Default value	4-set-up	Change during operation	Conversion index	Type
16-0* General status						
16-00	Control Word	0	All set-ups	FALSE	0	V2
16-01	Reference [Unit]	0.000 Unit	All set-ups	FALSE	-3	Int32
16-02	Reference %	0.0 %	All set-ups	FALSE	-1	Int16
16-03	Status word	0	All set-ups	FALSE	0	V2
16-05	Main actual value [%]	0	All set-ups	FALSE	0	N2
16-06	Alarm word	0	All set-ups	FALSE	0	Uint32
16-07	Warning word	0	All set-ups	FALSE	0	Uint32
16-08	Extended status word	0	All set-ups	FALSE	0	Uint32
16-1* Motor status						
16-10	Power [kW]	0.0 kW	All set-ups	FALSE	2	Uint32
16-11	Power [hp]	0.00 hp	All set-ups	FALSE	-2	Uint32
16-12	Motor voltage	0.0 V	All set-ups	FALSE	-1	Uint16
16-13	Frequency	0.0 Hz	All set-ups	FALSE	-1	Uint16
16-14	Motor current	0.00 A	All set-ups	FALSE	-2	Uint32
16-16	Torque	0.0 Nm	All set-ups	FALSE	-1	Int16
16-17	Speed [RPM]	0 RPM	All set-ups	FALSE	67	Int32
16-18	Motor thermal	0 %	All set-ups	FALSE	0	Uint8
16-3* Drive status						
16-30	DC link Voltage	0 V	All set-ups	FALSE	0	Uint16
16-32	Brake energy /s	0.0 HP	All set-ups	FALSE	0	Uint32
16-33	Brake energy /2 min	0.0 HP	All set-ups	FALSE	0	Uint32
16-34	Heatsink temp.	0 °C	All set-ups	FALSE	100	Uint8
16-35	Inverter thermal	0 %	All set-ups	FALSE	0	Uint8
16-36	InomVLT	Drive dependent	All set-ups	FALSE	-2	Uint16
16-37	ImaxVLT	Drive dependent	All set-ups	FALSE	-2	Uint16
16-38	SL controller state	0	All set-ups	FALSE	0	Uint8
16-39	Controlcard temp.	0 °C	All set-ups	FALSE	100	Uint8
16-5* Ref. & feedb.						
16-50	External reference	0.0	All set-ups	FALSE	-1	Int16
16-51	Pulse reference	0.0	All set-ups	FALSE	-1	Uint32
16-52	Feedback [Unit]	0.000	All set-ups	FALSE	-3	Int32
16-6* Inputs & outputs						
16-60	Digital input	0	All set-ups	FALSE	0	Uint16
16-61	Terminal 53 switch setting	[0] Current	All set-ups	FALSE	-	Uint8
16-62	Analog input 53	0.000	All set-ups	FALSE	-3	Int32
16-63	Terminal 54 switch setting	[0] Current	All set-ups	FALSE	-	Uint8
16-64	Analog input 54	0.000	All set-ups	FALSE	-3	Int32
16-65	Analog output 42 [mA]	0.000	All set-ups	FALSE	-3	Int16
16-66	Digital output [bin]	0	All set-ups	FALSE	0	Int16
16-67	Freq. input #29 [Hz]	0	All set-ups	FALSE	0	Int32
16-68	Freq. input #33 [Hz]	0	All set-ups	FALSE	0	Int32
16-69	Pulse output #27 [Hz]	0	All set-ups	FALSE	0	Int32
16-70	Pulse output #29 [Hz]	0	All set-ups	FALSE	0	Int32
16-8* Fieldbus & FC port						
16-80	Fieldbus CTW 1	0	All set-ups	FALSE	0	V2
16-82	Fieldbus REF 1	0	All set-ups	FALSE	0	N2
16-84	Comm. option STW	0	All set-ups	FALSE	0	V2
16-85	FC port CTW 1	0	All set-ups	FALSE	0	V2
16-86	FC port REF 1	0	All set-ups	FALSE	0	N2

* default setting () display text [] value for use in communication via serial communication port

General Specifications



Mains supply (L1, L2, L3):

Supply voltage	200-240 V ±10%
Supply voltage	FC 301: 380-480 V / FC 302: 380-500 V ±10%
Supply voltage	FC 302: 525-600 V ±10%
Supply frequency	50/60 Hz
Max. imbalance between mains phases	± 3.0 % of rated supply voltage
True Power Factor (λ)	0.90 nominal at rated load
Displacement Power Factor ($\cos \phi$) near unity	(> 0.98)
Switching on input supply L1, L2, L3	2 times/min.
Environment according to EN60664-1	overvoltage category 111/pollution degree 2
<i>The unit is suitable for use on a circuit capable of delivering not more than 100,000 RMS symmetrical Amperes, 240/500/600 V maximum.</i>	

Motor output (U, V, W):

Output voltage	0 - 100% of supply voltage
Output frequency	FC 301: 0.2 - 1000 Hz / FC 302: 0 - 1000 Hz
Switching on output	Unlimited
Ramp times	0.02 - 3600 sec.

Torque characteristics:

Starting torque (Constant torque)	160% for 1 min.*
Starting torque	180% up to 0.5 sec.*
Overload current (Constant torque)	160% for 1 min.*
<i>*Percentage relates to FC 300's nominal current.</i>	

Digital inputs:

Programmable digital inputs	FC 301: 4 (5) / FC 302: 4 (6)
Terminal number	18, 19, 27 ¹⁾ , 29 ¹⁾ , 32, 33, 37 ²⁾
Logic	PNP or NPN ³⁾
Voltage level	0 - 24 V DC
Voltage level, logic	'0' PNP logic < 5 V DC
Voltage level, logic	'1' PNP logic > 10 V DC



— General Specifications —

Voltage level, logic '0' NPN³) logic > 19 V DC
 Voltage level, logic "1 NPN³) logic < 14 V DC
 Maximum voltage on input 28 V DC
 Input resistance, R_i approx. 4 kΩ
All digital inputs are galvanically isolated from the supply voltage (PELV) and other high-voltage terminals.
 1) Terminal 27 and 29 can also be programmed as output.
 2) Terminal 37 is only available in FC 302. It can only be used as "safe stop" input. Terminal 37 is suitable for category 3 installations according to EN 954-1 (safe stop according to category 0 EN 60204-1).
 3) Exception: Terminal 37 is fixed PNP logic.

Analog inputs:

Number of analog inputs 2
 Terminal number 53, 54
 Modes Voltage or current
 Mode select Switch S201 and switch S202
 Voltage mode Switch S201/switch S202 = OFF (U)
 Voltage level FC 301: 0 to + 10 / FC 302: -10 to +10 V (scalable)
 Input resistance, R_i Approx. 10 kΩ
 Max. voltage ± 20 V
 Current mode Switch S201/switch S202 = ON (I)
 Current level 0/4 to 20 mA (scalable)
 Input resistance, R_i Approx. 200 Ω
 Max. current 30 mA
 Resolution for analog inputs 10 bit (+ sign)
 Accuracy of analog inputs Max. error 0.5% of full scale
 Band width FC 301: 20 Hz / FC 302: 100 Hz
The analog inputs are galvanically isolated from the supply voltage (PELV) and other high-voltage terminals.

Pulse/encoder inputs:

Programmable pulse/encoder inputs 2/1
 Terminal number pulse/encoder 29, 33¹⁾ / 18, 32, 33²⁾
 Max. frequency at terminal 18, 29, 32, 33 110 kHz (Push-pull driven)
 Max. frequency at terminal 18, 29, 32, 33 5 kHz (open collector)
 Min. frequency at terminal 18, 29, 32, 33 4 Hz
 Voltage level see section on digital input
 Maximum voltage on input 28 V DC
 Input resistance, R_i approx. 4 kΩ
 Pulse input accuracy (0.1 - 1 kHz) Max. error: 0.1% of full scale
 Encoder input accuracy (1 - 110 kHz) Max. error: 0.05 % of full scale
The pulse and encoder inputs (terminals 18, 29, 32, 33) are galvanically isolated from the supply voltage (PELV) and other high-voltage terminals.
 1) Pulse inputs are 29 and 33
 2) Encoder inputs: 18 = Z, 32 = A, and 33 = B

Digital output:

Programmable digital/pulse outputs 2
 Terminal number 27, 29 ¹⁾
 Voltage level at digital/frequency output 0 - 24 V
 Max. output current (sink or source) 40 mA
 Max. load at frequency output 1 kΩ
 Max. capacitive load at frequency output 10 nF



— General Specifications —

Minimum output frequency at frequency output 0 Hz
 Maximum output frequency at frequency output 32 kHz
 Accuracy on frequency output Max. error: 0.1 % of full scale
 Resolution on frequency outputs 12 bit
 1) Terminal 27 and 29 can also be programmed as input.

The digital output is galvanically isolated from the supply voltage (PELV) and other high-voltage terminals.

Analog output:

Number of programmable analog outputs 1
 Terminal number 42
 Current range at analog output 0/4 - 20 mA
 Max. load to common at analog output 500 Ω
 Accuracy on analog output Max. error: 0.5% of full scale
 Resolution on analog output 12 bit
The analog output is galvanically isolated from the supply voltage (PELV) and other high-voltage terminals.

Control card, 24 V DC output:

Terminal number 12, 13
 Max. load FC 301: 130 mA / FC 302: 200 mA
The 24 V DC supply is galvanically isolated from the supply voltage (PELV), but has the same potential as the analog and digital inputs and outputs.

Control card, 10 V DC output:

Terminal number 50
 Output voltage 10.5 V ±0.5 V
 Max. load 15 mA
The 10 V DC supply is galvanically isolated from the supply voltage (PELV) and other high-voltage terminals.

Control card, RS-485 serial communication:

Terminal number 68 (P,TX+, RX+), 69 (N,TX-, RX-)
 Terminal number 61 Common for terminals 68 and 69
The RS-485 serial communication circuit is functionally separated from other central circuits and galvanically isolated from the supplier voltage (PELV).

Control card, USB serial communication:

USB standard 2 (low speed)
 USB plug USB type B "device" plug
*Connection to PC is done via a standard host/device USB cable.
 The USB connection is galvanically isolated from the supply voltage (PELV) and other high-voltage terminals.*

Relay outputs:

Programmable relay outputs FC 301: 1 / FC 302: 2
 Terminal number, power card 1-3 (break), 1-2 (make), 4-6 (break), 4-5 (make)
 Max. terminal load (AC) on 1-3 (break), 1-2 (make), 4-6 (break) power card 240 V AC, 2 A
 Max. terminal load (AC) on 4-5 (make) power card 400 V AC, 2 A
 Min. terminal load on 1-3 (break), 1-2 (make), 4-6 (break), 4-5 (make) power card 24 V DC 10 mA, 24 V AC 100 mA
 Environment according to EN 60664-1 overvoltage category 111/pollution degree 2
The relay contacts are galvanically isolated from the rest of the circuit by reinforced isolation (SELV).



— General Specifications —

Cable lengths and cross -sections:

Max. motor cable length, shielded/armored FC 301: 164 ft (50 m) / FC 302: 492 ft (150 m)
 Max. motor cable length, non-shielded/unarmored FC 301: 246 ft (75 m) / FC 302: 984 ft (300 m)
 Max. cross-section to motor, mains, load sharing and brake (see section Electrical Data in the
 FC 300 Design Guide MG.33.BX.YY for more information), (0.34 HP - 10 HP / 0.25 kW - 7.5
 kW) 0.006 in.² (4 mm²) / 10 AWG
 Maximum cross-section to control wires, rigid wire
 0.002 in.² (1.5 mm²)/16 AWG (2 x 0.001 in.² (2 x 0.75 mm²))
 Maximum cross-section to control cables, flexible cable 0.0015 in.² (1 mm²)/18 AWG
 Maximum cross-section to control cables, cable with enclosed core 0.0008 in.² (0.5 mm²)/20 AWG
 Minimum cross-section to control wires 0.0004 in.² (0.25 mm²)

Cable lengths and RFI performance			
FC 30x	Filter	Supply voltage	RFI compliance at max. motor cable lengths
FC 301	With A2 filter	200 - 240 V / 380 - 500 V /	<16 ft (5 m) EN 55011 Group A2
FC 302		400 - 500 V	
FC 301	With A1/B	200 - 240 V / 400 - 500 V	<131 ft (40 m) EN 55011 Group A1
FC 302			<33 ft (10 m) EN 55011 Group B
FC 301	With A1/B	200 - 240 V / 380 - 500 V	<492 ft (150 m) EN 55011 Group A1
FC 302			<131 ft (40 m) EN 55011 Group B
FC 302	No RFI filter	550 - 600 V	Not compliant with EN 55011

In certain instances, shorten the motor cable to comply with EN 55011 A1 and EN 55011 B.
 Copper (140/167°F, 60/75°C) conductors recommended.

Aluminum conductors

Aluminum conductors are not recommended. Terminals can accept aluminum conductors but the conductor surface must be clean and the oxidation must be removed and sealed by neutral acid-free Vaseline grease before the conductor is connected.
 Furthermore, the terminal screw must be retightened after two days due to the softness of the aluminum. It is crucial to keep the connection a gas-tight joint, otherwise the aluminum surface will oxidize again.

Control card performance:

Scan interval FC 301: 10 ms / FC 302: 1 ms

Control characteristics:

Resolution of output frequency at 0 - 1000 Hz FC 301: +/- 0.013 Hz / FC 302: +/- 0.003 Hz
 Repeat accuracy of *Precise start/stop* (terminals 18, 19) FC 301: ≤ ± 1ms / FC 302: ≤ ± 0.1 ms
 System response time (terminals 18, 19, 27, 29, 32, 33) FC 301: ≤ 20 ms / FC 302: ≤ 2 ms
 Speed control range (open loop) 1:100 of synchronous speed
 Speed control range (closed loop) 1:1000 of synchronous speed
 Speed accuracy (open loop) 30 - 4000 rpm: Maximum error of ±8 rpm
 Speed accuracy (closed loop) 0 - 6000 rpm: Maximum error of ±0.15 rpm
All control characteristics are based on a 4-pole asynchronous motor

Hz
V
A
IP
°C
Ω

— General Specifications —

Surroundings:

Enclosure	IP 20
Enclosure kit available	IP21/TYPE 1/IP 4X top
Vibration test	1.0 g
Max. relative humidity	5, 95, 721, -3, -3 Class 3K3 (non-condensing) during operation
Aggressive environment (IEC 721-3-3), uncoated	class 3C2
Aggressive environment (IEC 721-3-3), coated	class 3C3
Ambient temperature	Maximum 122 °F (50 °C)(24-hour average max. 113 °F (45 °C))
<i>Derating for ambient temperature, see special conditions in the Design Guide</i>	
Minimum ambient temperature during full-scale operation	32 °F (0 °C)
Minimum ambient temperature at reduced performance	14 °F (-10 °C)
Temperature during storage/transport	-13 - +150/160 °F (-25 - +65/70 °C)
Maximum altitude above sea level	3300 ft (1000 m)
<i>Derating for ambient temperature, see special conditions in the Design Guide</i>	
EMC standards, Emission	EN 61800-3, EN 61000-6-3/4, EN 55011, (EN 50081-1/2)
EMC standards, Immunity	EN 61800-3, EN 61000-6-1/2, EN 61000-4-2, EN 61000-4-3, EN 61000-4-4, EN 61000-4-5, EN 61000-4-6, (EN 50082-1/2)
<i>See section on special conditions in the Design Guide</i>	

Protection and Features:

-
- Electronic thermal motor protection against overload.
 - Temperature monitoring of the heat sink ensures that the trips if the temperature reaches 203 °F ± 9 °F (95 °C ± 5 °C). An overload temperature cannot be reset until the temperature of the heat sink is below 158 °F ± 9 °F (70 °C ± 5 °C).
 - The adjustable frequency drive is protected against short circuits on motor terminals U, V, W.
 - If a mains phase is missing, the adjustable frequency drive trips or issues a warning.
 - Monitoring of the intermediate circuit voltage ensures that the adjustable frequency drive trips if the intermediate circuit voltage is too low or too high.
 - The adjustable frequency drive is protected against ground faults on motor terminals U, V, W.



— General Specifications —



Troubleshooting



□ Warnings/Alarm Messages

A warning or an alarm icon appears in the display as well as a text string describing the problem. A warning is shown on the display until the fault has been corrected, while an alarm will continue to flash on the LED until you activate the [RESET] key. The table shows the various warnings and alarms, and whether the fault locks the FC 300. After an *Alarm/Trip locked*, cut off the mains supply and correct the fault. Reconnect mains supply. The FC 300 is now reset. An *Alarm/Trip* can be reset manually in three ways:

1. Via the operating key [RESET].
2. Via a digital input.
3. Via serial communication.

You can also choose an automatic reset in parameter 14-20 *Reset mode*. When a cross appears in both warning and alarm, it means that either a warning comes before an alarm or that you can define whether a warning or an alarm appears for a given fault. For example, this is possible in parameter 1-90 *Motor thermal protection*. After an alarm/trip, the motor will coast, and alarm and warning will flash on the FC 300. If the fault disappears, only the alarm will flash.



— Troubleshooting —

No.	Description	Warning	Alarm/Trip	Alarm/Trip locked
1	10 Volts low	X		
2	Live zero error	(X)	(X)	
3	No motor	X		
4	Mains phase loss	X	X	X
5	DC link voltage high	X		
6	DC link voltage low	X		
7	DC overvoltage	X	X	
8	DC undervoltage	X	X	
9	Inverter overloaded	X	X	
10	Motor ETR over temperature	X	X	
11	Motor thermistor over temperature	X	X	
12	Torque limit	X	X	
13	Overcurrent	X	X	X
14	Ground fault	X	X	X
16	Short Circuit		X	X
17	Control word timeout	(X)	(X)	
25	Brake resistor short-circuited	X		
26	Brake resistor power limit	X	X	X
27	Brake chopper fault	X		
28	Brake check	X	X	
29	Drive over temperature	X	X	X
30	Motor phase U missing		X	X
31	Motor phase V missing		X	X
32	Motor phase W missing		X	X
33	Inrush fault		X	X
34	Fieldbus communication fault	X	X	
38	Internal fault		X	X
47	24 V supply low	X	X	X
48	1.8V supply low		X	X
49	Speed limit	X		
50	AMA calibration failed		X	
51	AMA check Unom and Inom		X	
52	AMA low Inom		X	
53	AMA motor too big		X	
54	AMA motor too small		X	
55	AMA parameter out of range		X	
56	AMA interrupted by user		X	
57	AMA timeout		X	
58	AMA internal fault		X	
59	Current limit	X		
61	Encoder loss	(X)	(X)	
62	Output Frequency at Maximum Limit	X		
63	Mechanical Brake Low		X	
64	Voltage Limit	X		
65	Control Card Overheating	X	X	X
66	Heatsink Temperature Low	X		
67	Option Configuration has Changed		X	
68	Safe Stop Activated		X	
80	Drive Initialized to Default Value		X	
(X)	Dependent on parameter			



— Troubleshooting —

LED indication	
Warning	yellow
Alarm	flashing red
Trip locked	yellow and red

WARNING 1

10 Volts low:

The 10 V voltage from terminal 50 on the control card is below 10 V. Remove some of the load from terminal 50, as the 10 V supply is overloaded. Max. 15 mA or minimum 590 Ω.

WARNING/ALARM 2

Live zero error:

The signal on terminal 53 or 54 is less than 50% of the value set in par. 6-10, 6-12, 6-20, or 6-22 respectively.

WARNING/ALARM 3

No motor:

No motor has been connected to the output of the adjustable frequency drive.

WARNING/ALARM 4

Mains phase loss:

A phase is missing on the supply side, or the mains voltage imbalance is too high. This message also appears in case of a fault in the input rectifier on the adjustable frequency drive. Check the supply voltage and supply currents to the adjustable frequency drive.

WARNING 5

DC link voltage high:

The intermediate circuit voltage (DC) is higher than the overvoltage limit of the control system. The adjustable frequency drive is still active.

WARNING 6:

DC link voltage low

The intermediate circuit voltage (DC) is below the undervoltage limit of the control system. The adjustable frequency drive is still active.

WARNING/ALARM 7

DC over voltage:

If the intermediate circuit voltage exceeds the limit, the adjustable frequency drive trips after a time. Possible corrections:

- Connect a brake resistor
- Extend the ramp time
- Activate functions in par. 2-10
- Increase par. 14-26



— Troubleshooting —

Connect a brake resistor. Extend the ramp time

Alarm/warning limits:			
FC 300 Series	3 x 200 - 240 V	3 x 380 - 500 V	3 x 525 - 600 V
	[VDC]	[VDC]	[VDC]
Undervoltage	185	373	532
Voltage warning low	205	410	585
Voltage warning high (w/o brake - w/brake)	390/405	810/840	943/965
Overvoltage	410	855	975

The voltages stated are the intermediate circuit voltage of the FC 300 with a tolerance of ± 5 %. The corresponding mains voltage is the intermediate circuit voltage (DC-link) divided by 1.35

WARNING/ALARM 8

DC under voltage:

If the intermediate circuit voltage (DC) drops below the "voltage warning low" limit (see table above), the adjustable frequency drive checks if 24 V backup supply is connected.

If no 24 V backup supply is connected, the adjustable frequency drive trips after a given time depending on the unit.

To check whether the supply voltage matches the adjustable frequency drive, see *General Specifications*.

WARNING/ALARM 9

Inverter overloaded:

The adjustable frequency drive is about to cut out because of an overload (too high current for too long). The counter for electronic thermal inverter protection gives a warning at 98% and trips at 100%, while giving an alarm. You cannot reset the adjustable frequency drive until the counter is below 90%.

The fault is that the adjustable frequency drive is overloaded by more than 100% for too long.

WARNING/ALARM 10

Motor ETR over temperature:

According to the electronic thermal protection (ETR), the motor is too hot. You can choose if

you want the adjustable frequency drive to give a warning or an alarm when the counter reaches 100% in par. 1-90. The fault is that the motor is overloaded by more than 100% for too long. Check that the motor par. 1-24 is set correctly.

WARNING/ALARM 11

Motor thermistor over temp:

The thermistor or the thermistor connection is disconnected. You can choose if you want the adjustable frequency drive to give a warning or an alarm when the counter reaches 100% in par. 1-90. Check that the thermistor is connected correctly between terminal 53 or 54 (analog voltage input) and terminal 50 (+ 10 Volts supply), or between terminal 18 or 19 (digital input PNP only) and terminal 50. If a KTY sensor is used, check for correct connection between terminal 54 and 55.

WARNING/ALARM 12

Torque limit:

The torque is higher than the value in par. 4-16 (in motor operation) or the torque is higher than the value in par. 4-17 (in regenerative operation).

WARNING/ALARM 13

Over Current:

The inverter peak current limit (approx. 200% of the rated current) is exceeded. The warning will last approx. 8-12 sec., then the adjustable frequency drive trips and issues an alarm. Turn off the adjustable frequency drive and check if the crankshaft can be turned and if the motor size matches the adjustable frequency drive.

If extended mechanical brake control is selected, trip can be reset externally.

ALARM: 14

Ground fault:

There is a discharge from the output phases to ground, either in the cable between the adjustable frequency drive and the motor or in the motor itself. Turn off the adjustable frequency drive and remove the ground fault.

ALARM: 16

Short-circuit:

There is short circuiting in the motor or on the motor terminals. Turn off the adjustable frequency drive and remove the short circuit.



— Troubleshooting —

WARNING/ALARM 17**Control word timeout:**

There is no communication to the adjustable frequency drive.

The warning will only be active when par. 8-04 is NOT set to *OFF*.

If par. 8-04 is set to *Stop* and *Trip*, a warning appears and the adjustable frequency drive ramps down until it trips, while giving an alarm.

par. 8-03 *Control word Timeout Time* could possibly be increased.

WARNING 25**Brake resistor short-circuited:**

The brake resistor is monitored during operation. If it short circuits, the brake function is disconnected and the warning appears. The adjustable frequency drive still works, but without the brake function.

Turn off the adjustable frequency drive and replace the brake resistor (see par. 2-15 *Brake Check*.)

ALARM/WARNING 26**Brake resistor power limit:**

The power transmitted to the brake resistor is calculated as a percentage, as a mean value over the last 120 s, on the basis of the resistance value of the brake resistor (par. 2-11) and the intermediate circuit voltage. The warning is active when the dissipated braking energy is higher than 90%. If *Trip* [2] has been selected in par. 2-13, the adjustable frequency drive cuts out and issues this alarm when the dissipated braking energy is higher than 100%.

WARNING 27**Brake chopper fault:**

The brake transistor is monitored during operation and if it short circuits, the brake function disconnects and the warning comes up. The adjustable frequency drive is still able to run, but since the brake transistor has short circuited, substantial power is transmitted to the brake resistor, even if it is inactive.

Turn off the adjustable frequency drive and remove the brake resistor.



Warning: There is a risk of substantial power being transmitted to the brake resistor if the brake transistor is short circuited.

ALARM/WARNING 28**Brake check failed:**

Brake resistor fault: the brake resistor is not connected/working.

ALARM 29**Drive over temperature:**

If the enclosure is IP 20 or IP 21/TYPE 1, the cut-out temperature of the heat sink is 203 °F ±9 °F (95 °C ±5 °C). The temperature fault cannot be reset until the temperature of the heat sink is below 158 °F ±9 °F (70 °C ±5 °C).

The fault could be:

- Ambient temperature too high
- Too long motor cable

ALARM 30**Motor phase U missing:**

Motor phase U between the adjustable frequency drive and the motor is missing.

Turn off the adjustable frequency drive and check motor phase U.

ALARM 31**Motor phase V missing:**

Motor phase V between the adjustable frequency drive and the motor is missing.

Turn off the adjustable frequency drive and check motor phase V.

ALARM 32**Motor phase W missing:**

Motor phase W between the adjustable frequency drive and the motor is missing.

Turn off the adjustable frequency drive and check motor phase W.

ALARM: 33**Inrush fault:**

Too many power-ups have occurred within a short time period. See the chapter *General Specifications* for the allowed number of power-ups within one minute.

WARNING/ALARM 34**Fieldbus communication fault:**

The fieldbus on the communication option card is not working.



— Troubleshooting —

WARNING 35**Out of frequency range:**

This warning is active if the output frequency has reached its *Warning speed low* (par. 4-52) or *Warning speed high* (par. 4-53). If the adjustable frequency drive is in *Process control, closed loop* (par. 1-00), the warning is active in the display. If the adjustable frequency drive is not in this mode, bit 008000 *Out of frequency range* in extended status word is active but there is no warning in the display.

ALARM 38**Internal fault:**

Contact your Danfoss supplier.

WARNING 47**24 V supply low:**

The external 24 V DC backup power supply may be overloaded, otherwise Contact your Danfoss supplier.

WARNING 48**1.8 V supply low:**

Contact your Danfoss supplier.

WARNING 49**Speed limit:**

Contact your Danfoss supplier.

ALARM 50**AMA calibration failed:**

Contact your Danfoss supplier.

ALARM 51**AMA check Unom and Inom:**

The setting of motor voltage, motor current, and motor power is presumably wrong. Check the settings.

ALARM 52**AMA low Inom:**

The motor current is too low. Check the settings.

ALARM 53**AMA motor too big:**

The motor is too big for the AMA to be carried out.

ALARM 54**AMA motor too small:**

The motor is too small for the AMA to be carried out.

ALARM 55**AMA par. out of range:**

The par. values found from the motor are outside the acceptable range.

ALARM 56**AMA interrupted by user:**

The AMA has been interrupted by the user.

ALARM 57**AMA timeout:**

Try to start the AMA again a number of times, until the AMA is carried out. Please note that repeated runs may heat the motor to a level where the resistance R_s and R_r is increased. In most cases, however, this is not critical.

ALARM 58**AMA internal fault:**

Contact your Danfoss supplier.

WARNING 59**Current limit:**

Contact your Danfoss supplier.

WARNING 61**Encoder loss:**

Contact your Danfoss supplier.

WARNING 62**Output Frequency at Maximum Limit:**

The output frequency is higher than the value set in par. 4-19

ALARM 63**Mechanical Brake Low:**

The actual motor current has not exceeded the "release brake" current within the "Start delay" time window.

WARNING 64**Voltage Limit:**

The load and speed combination demands a motor voltage higher than the actual DC link voltage.

WARNING/ALARM/TRIP 65**Control Card Over Temperature:**

Control card over temperature: The cut-out temperature of the control card is 176 °F (80 °C).

WARNING 66**Heatsink Temperature Low:**

The heat sink temperature is measured as 0° C. This could indicate that the temperature sensor is defect and thus the fan speed is increased to the maximum in case the power part or control card is very hot.

ALARM 67

Option Configuration has Changed:



— Troubleshooting —

One or more options has either been added or removed since the last power-down.

ALARM 68

Safe Stop Activated:

Safe Stop has been activated. To resume normal operation, apply 24 V DC to terminal 37, then send a reset signal (via Bus, Digital I/O, or by pressing [RESET]).

ALARM 80

Drive Initialized to Default Value

Parameter settings are initialized to default setting after a manual (three-finger) reset.





Index

A

Abbreviations	6
Access to Control Terminals	17
Accessory Bag	10
Alarm Messages	55
Alarm/Trip	55
Alarm/Trip locked	55
Analog inputs	50
Analog output	51
Approvals	5
Automatic Motor Adaptation	32
Automatic Motor Adaptation (AMA)	22
Automatic reset	55

B

Brake Connection Option	24
Brake control	58

C

Cable lengths and cross-sections	51
Cable lengths and RFI performance	52
Communication option	59
Connection to Mains	12
Control cables	20
Control card performance	52
Control card, +10 V DC output:	51
Control card, 24 V DC output	51
Control card, RS-485 serial communication	51
Control card, USB serial communication	51
Control characteristics	52
Control of Mechanical Brake	25
Control Terminals	17, 18

D

DC link	57
Decoupling plate	13
Default settings	35
DeviceNet	4
Digital inputs:	49
Digital output	50
Display Contrast	30

E

Electrical Installation	17
Electrical Installation, Control Cables	19
ETR	58
External 24 V DC supply	23

F

Fuses	15
-------------	----

G

General warning	8
Graphical display	27
Ground connection	12
Ground leakage current	7

I

Indicator lights	28
Intermediate circuit	23, 57
IP21 / TYPE 1	4

K

KTY sensor	58
------------------	----

L

Language	32
LC filter	14
LCP	29
LCP 102	27
Leakage Current	8
LEDs	27
Load Sharing	23
Local Control Panel	27

M

Mechanical dimensions	11
motor nameplate	21

— Index —

Main reactance 33
 Mains plug connector 12
 Mains supply (L1, L2, L3)..... 49
 MCT 10 4
 Mechanical Installation..... 11
 Motor cables 14
 Motor Connection 13
 Motor current 32
 Motor frequency..... 32
 Motor nominal speed 32
 Motor output..... 49
 Motor overload protection 7
 Motor Power 32
 Motor protection 53
 Motor Voltage..... 32

N

Nameplate data 21, 21
 Non-UL compliance 16

O

Output data (U, V, W) 49

P

Parallel connection of motors 26
 Potentiometer reference 31
 Profibus 4
 Protection 15
 Protection and Features 53
 Pulse start/stop 31
 Pulse/encoder inputs 50

Q

Quick Menu 28
 Quick Transfer of Parameter Settings 29

R

ramp-down time 33
 Ramp 1 ramp up time 33
 Relay connection 25
 Relay outputs 51
 Repair work 7
 Reset 28

Residual Current Device 8

S

shielded/armored 20
 Safety Instructions 7
 Serial communication 51
 Shaft performance level 3
 Side-by-side installation 12
 Speed up/slow down 31
 Start torque..... 7
 Start/stop 31
 Stator leakage reactance 33
 Status 28
 Status messages 27
 Surroundings 52
 Switches S201, S202, and S801 20
 Symbols 5

T

Thermal motor protection 26
 Tightening Torques 21
 Torque characteristics 49

U

USB Connection 18

V

Voltage level 49

W

Warnings 55

2

24 V Backup Option 23
 24 V DC Backup 4