

■ Contents

Safety and precautions	3
Safety regulations	4
Warning against unintended start	4
Operation modes	6
Cascade Control Operation	6
Standard Cascade Control Mode	7
Lead Pump Alternation	7
Master/Slave Cascade Control Mode	8
Installation and Wiring Instructions	9
Installing the Cascade Controller Option Card	9
Standard cascade control wiring diagram	16
Optional Hand/Off/Auto Switch	17
Lead Pump Alternation Wiring Diagram	18
Master drive in master/slave control wiring diagram	19
Slave drive in master/slave control wiring diagram	20
Changed Drive functions	21
Introduction	21
Changed systemstop functions	22
Serial communications (parameter 500)	22
User Interface	23
How to use the LCP for programming	23
Control keys for parameter setup	23
Indicator lamps	23
Drive Control	23
Display modes	24
Changing data	26
Parameter setting procedure	26
Example of how to change parameter data	26
Manual initialization	27
VLT Drive and Cascade Controller Setup	28
Introduction	28
Quick Menu Summary	29
Language	30
Motor nameplate data	30
Relay outputs	32
Alternate programming	36
Standard Cascade Controller Setup	38
Introduction	38
Initial Setup	39
Alternate programming	47
Master/Slave Cascade Control Setup	48

Introduction	48
Initial Setup	48
Step 1: Master drive programming	48
Step 2: Slave drive programming	51
Alternate programming:	52
System Optimisation	54
System start up and final adjustments	54
Best efficiency frequency	54
Optimization of the process regulator	55
Feedback Transmitter Wiring	56
Connecting feedback transmitters	56
Single 0 - 10 V feedback transmitter connection:	56
Two 0 - 10 V feedback transmitter connections:	56
Two 4 - 20 mA feedback transmitters connection:	57
Two feedback signals and two setpoints:	57
Programming example	57
Parameter group 700, all parameters	59
Parameter group 700 definitions	59
Service parameters	61
Display information	61
Relay status	62

■ Safety and precautions

175ZA677.12

Cascade Controller Option
for
VLT 6000 HVAC
and
VLT 8000 AQUA

Operating Instructions
Software version: 2.0x

These Operating Instructions can be used with all
cascade controller options with software version 2.0x.
The software version can be seen from parameter 624.

Safety and
precautions

When reading through this Operating Instructions,
you will come across various symbols that
require special attention.

The symbols used are the following:



Indicates a general warning.



NB!:

Indicates something to be noted by the reader.



Indicates a high-voltage warning.



The voltage of the frequency converter is dangerous whenever the equipment is connected to mains. Incorrect installation of the motor or the frequency converter may cause damage to the equipment, serious personal injury or death. Consequently, the instructions in this manual, as well as national and local rules and safety regulations, must be complied with.



NB!:

Using the MCT 10 Set-up Software or the FC protocol for serial communication can cause unintended behaviour of motors and plant and must be avoided.

■ Safety regulations

1. The frequency converter must be disconnected from mains if repair work is to be carried out. Check that the mains supply has been disconnected and that the necessary time has passed before removing motor and mains plugs.
2. The [OFF/STOP] key on the control panel of the frequency converter does not disconnect the equipment from mains and is thus not to be used as a safety switch.



NB!:

The IMMEDIATE STOP function will release all slave relays and can not be used as a safety switch. The SEQUENCED STOP will stage off the slave relays and can not be used as a safety switch

3. Correct protective earthing of the equipment must be established, the user must be protected against supply voltage, and the motor must be protected against overload in accordance with applicable national and local regulations.
4. The earth leakage currents are higher than 3.5 mA.
5. Protection against motor overload is included in the factory setting. Parameter 117, Motor thermal protection, default value is ETR trip
 1. For the North American market: The ETR functions ensure overload protection of the motor, Class 20, in accordance with NEC.



NB!:

Motor Thermal Protection is initialised at 1.0 x rated motor current and rated motor frequency (see parameter 117, *Motor thermal protection*).

6. Do not remove the plugs for the motor and mains supply while the frequency converter is connected to mains. Check that the mains supply has been disconnected and that the necessary time has passed before removing motor and mains plugs.

7. Reliable galvanic isolation (PELV) is not complied with if the RFI switch is placed in OFF position. This means that all control in- and outputs can only be considered low-voltage terminals with basic galvanic isolation.
8. Please note that the frequency converter has more voltage inputs than L1, L2, L3 when the DC-bus terminals are used. Check that all voltage inputs have been disconnected and that the necessary time has passed before repair work is commenced.

■ Warning against unintended start

1. The motor can be brought to a stop by means of digital commands, bus commands, references or a local stop, while the frequency converter is connected to mains. If personal safety considerations make it necessary to ensure that no unintended start occurs, these stop functions are not sufficient.
2. While parameters are being changed, the motor may start. Consequently, the stop key [OFF/ STOP] must always be activated, after which data can be modified.



Warning:

Touching the electrical parts may be fatal - even after the equipment has been disconnected from mains.

6002 - 6005, 200-240 V:	wait at least 4 minutes
6006/8006 - 6062/8062, 200-240 V:	wait at least 15 minutes
6002 - 6005, 380-460 V:	wait at least 4 minutes
6006/8006 - 6072/8072, 380-460 V/480 V:	wait at least 15 minutes
6102/8102 - 6352/8352, 380-460 V/480 V:	wait at least 20 minutes
6400/8450 - 6550/8600, 380-460 V/480 V:	wait at least 15 minutes
6002/8002 - 6006/8006, 525-600 V:	wait at least 4 minutes
6008/8008 - 6027/8027, 525-600 V:	wait at least 15 minutes
6032/8032 - 6275/8300, 525-600 V:	wait at least 30 minutes

175ZA678.12

Safety and
precautions

■ Operation modes

■ Cascade Control Operation

With the cascade controller option card, the frequency converter can automatically control up to five motors. Staging motors on or off is done cyclically, in accordance with operating hours. This function assures equal use over time and eliminates concern about starting a seldom used motor. The cascade controller includes four Form C relays having contacts rated 250 V, 2 A (non-inductive) that are used to control the motor contactors. The controller option card installs in the frequency converter control card cassette and can be ordered factory installed. The cascade controller is effective in applications where multiple motors are used to control a common flow, level or pressure involving pumps, fans, and blowers.

Feedback Signals

An important advantage to the cascade controller option is that it is based upon the frequency converter's advanced PID controller. This means that programming is done in selected units of measurement appropriate to the application and that the feedback and setpoints can be displayed. Unlike drives that base staging upon frequency, feedback allows precise control in response to actual system demand. The frequency converter's PID controller accommodates two feedback signals and two setpoints which allows regulating a system with different setpoint zones.

In pumping applications, when a pressure feedback signal is not practical, the feedback signal may be taken near the pump by measuring flow. When the flow rate is low, the pressure needed is low. At increased flow, the pumps need to provide greater pressure to compensate for the increased pressure drop in the piping. The setpoint should be adjusted to match the flow in these cases. While difficult to accomplish with standard PID controllers, the cascade controller provides an easy solution. By programming one setpoint for minimum flow and the other for maximum flow, the frequency converter calculates intermediate setpoints based on the flow required.

Cascade control operation depends on the general system design. Two operational modes are available:

1. *Standard Cascade Control*, with one speed controlled pump/fan and up to four fixed speed pumps/fans. *Lead pump alternation* makes it possible to average out the use of the pumps. This is done by cycling the lead pump in the system. Up to four pumps can be controlled this way. Programming for this mode is described in Chapter 6, *Standard Cascade Control Mode Setup*.
2. *Master / Slave Cascade Control* has all pumps/fans speed controlled through the Master drive. Programming is described in Chapter 7, *Master/Slave Cascade Control Mode Setup*.

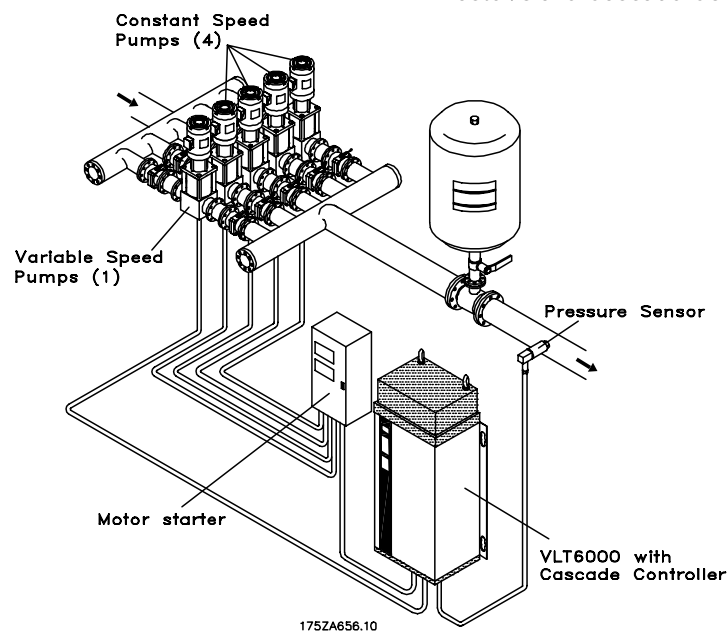

Standard Cascade Control Mode

■ **Standard Cascade Control Mode**

In standard cascade control, a frequency converter with the Cascade Controller option card installed controls a variable speed motor and is used to stage additional constant speed motors on and off. By varying the speed of the initial motor, variable speed control is provided for the system. This maintains constant pressure while eliminating pressure surges, resulting in reduced system stress and quieter operation.

The motors can be of equal or differing sizes. The controller offers a selection of eight pre-defined pump combinations. Selections allow mixing pumps of 100%, 200% and 300% capacity. This provides a dynamic capacity range of 9 to 1. The frequency converter's internal PID controller directs the cascade option card based upon the feedback signal. The cascade controller will continue operation of the constant speed motors to meet demand should the drive trip.

De-stage Timer

A de-stage timer takes effect in standard control when the drive runs continuously at minimum speed with

one or more constant speed motors running. Since a variable speed pump at minimum speed adds no or very limited flow to the system, it is advisable to stop a constant speed motor and allow the drive to provide the required flow. The de-stage timer is programmable to avoid frequent staging of the constant speed motors.

When the master drive is the only one running, the drive's sleep mode can discontinue system operation when not needed while staying ready to start on demand. Variable speed control with fixed speed motors optimizes energy consumption and avoids damaging a pump running at near no flow condition

Level Control

With level control, multiple pumps can be used to keep a constant level in applications such as a buffer tank. Typically, a water level sensor provides a feedback signal for the frequency converter's built-in PID controller. Precise level control is maintained in response to the system setpoint. With a cascade controller, additional fixed speed pumps will be staged on or off, as required, to maintain level control.

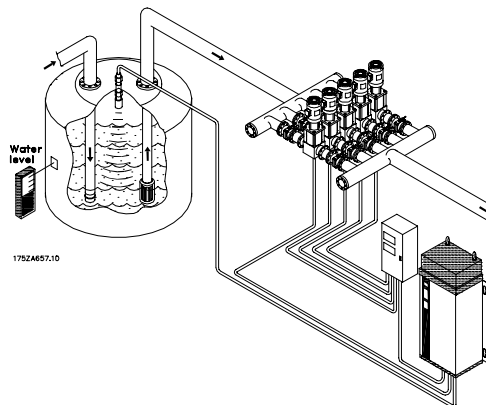

Level Control in Standard Cascade Control Mode

■ **Lead Pump Alternation**

The function makes it possible to cycle the frequency converter between the pumps in the system (max. 4 pumps). In this way the use of all the pumps can be averaged out and there is no risk that a pump gets stuck due to corrosion and lack of operation. This reduces maintenance, increased reliability and increases lifetime of the system. The changeover of the frequency converter from one pump to the other is controlled by means of a timer, so that it is possible to set the desired time interval between a change. Only 100% capacity pumps can be used.

Operation modes

■ Master/Slave Cascade Control Mode

Master/slave systems control multiple pumps in parallel at the same output frequency. Pumps are staged on and off as required to meet the system's demand. The master/slave control mode of operation provides maximum system efficiency.

In master/slave control, each motor has its own frequency converter which responds to control from a master drive which contains the cascade option card. The master drive sends a pulse speed reference signal to the drives under control to ensure that all operate at the same speed. The motors must be of equal size. In some applications, it may be advisable for a second drive with a cascade card to act as an auxiliary controller.

Sequential staging of drives on or off is provided by the master drive in response to system feedback, maintaining precise setpoint control. Pressure surge and water hammer are eliminated. Because all of the operating pumps run at the same speed, the possibility of running a pump continuously into a closed check valve is all but eliminated. This reduces pump maintenance by minimizing the wear on pump seals and bearings.

Danfoss has available the Multiple Unit Staging Efficiency Calculator (MUSEC), a free software program available on the Danfoss website. By entering pump and system data, MUSEC provides the programmer with master drive on and off staging frequencies at optimal efficiency for each pump: for example, three motors providing flow at reduced speed rather than two at full speed. This often results in 10% to 15% additional savings over similar control systems. For a free download, go to www.danfoss.com/drives and go to software download.

Best efficiency is attained when a pressure transmitter is placed at the farthest significant load in the system. If this is not practical and the pressure transmitter is placed close to the discharge of the pumps, or when pump data and system characteristics are not accessible, alternative ways of programming the cascade controller are provided.

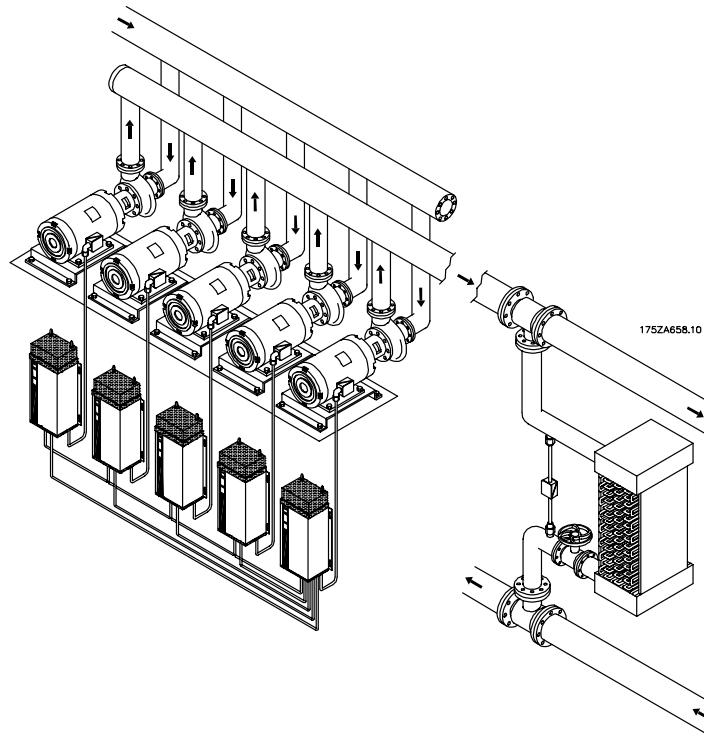

Master/Slave Cascade Control Mode

■ Installation and Wiring Instructions

■ Installing the Cascade Controller Option Card

This chapter provides instructions for installing the cascade controller option card into a frequency converter. In Standard cascade control mode, the option card installs into the frequency converter controlling up to four additional motors. In Master/Slave mode, the option card installs in the Master drive controlling up to four additional slave drives.

Relay output connections vary according to the mode of operation and configuration of the system. Typical wiring diagrams are also provided in this chapter.

Adhere to all safety guidelines provided in the *VLT 6000 Operating Instructions MG.60.AX.YY* and the *VLT*

8000 Operating Instructions MG.80.AX.YY respectively. See the relevant *VLT Operating Instructions* for details and for instructions on drive operation.

Torque tightening requirements

Tighten all fittings described in this chapter to 7.1 in-lbs (0.8 Nm), unless specified otherwise.

Optional transmitter connections

Terminals 12 and 13 provide a 24 V DC, 200 mA power supply. This supply can be used to power remote transmitters without need for an external power supply. See wiring instructions in Chapter 10, *Feedback Transmitter Wiring*.



DANGER

The frequency converter contains dangerous voltages when connected to line voltage. Touching the electrical parts may be fatal - even after the equipment has been disconnected from mains.

6002 - 6005, 200-240 V:	wait at least 4 minutes
6006/8006 - 6062/8062, 200-240 V:	wait at least 15 minutes
6002 - 6005, 380-460 V:	wait at least 4 minutes
6006/8006 - 6072/8072, 380-460/480 V:	wait at least 15 minutes
6102/8102 - 6352/8352, 380-460/480 V:	wait at least 20 minutes
6400/8450 - 6550/8600, 380-460/480 V:	wait at least 15 minutes
6002/8002 - 6006/8006, 525-600 V:	wait at least 4 minutes
6008/8008 - 6027/8027, 525-600 V:	wait at least 15 minutes
6032/8032 - 6275/8300, 525-600 V:	wait at least 30 minutes



WARNING

Only a competent electrician should carry out electrical installation. Improper installation of motor or frequency converter can cause equipment failure, serious injury or death. Follow this manual and National Electrical Code and local safety codes.



CAUTION

Electronic components of the frequency converter are sensitive to electrostatic discharge (ESD). ESD can reduce performance or destroy sensitive electronic components. Follow proper ESD procedures during installation or servicing to prevent damage.

Cascade Controller Option

■ 1. Access to Control Card Cassette

- Remove Local Control Panel (LCP) keypad by pulling out from top by hand. LCP connector on panel back will disconnect.
- Remove terminal protective cover by gently prying with screw driver at top notch and lift cover out of guide pin fittings.
- Open access cover to internal frequency converter components. (Drive configurations vary.)

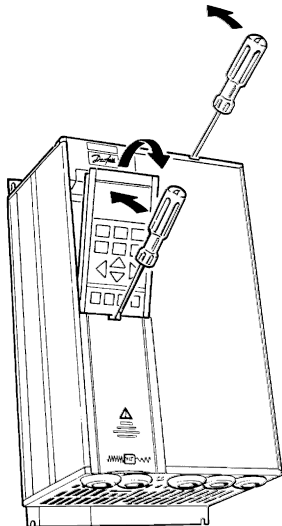

175ZA178.10

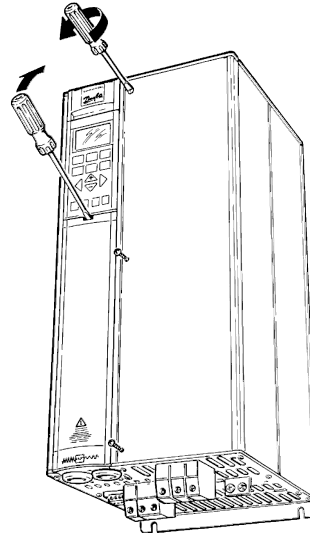

175ZT232.10

■ 2. Disconnect VLT Drive Control Wiring

- Remove control wiring by unplugging connector terminals.
- Remove wiring clamp by removing two screws. Save for reassembly.
- Loosen two captive screws securing control board cassette to the frequency converter's chassis.

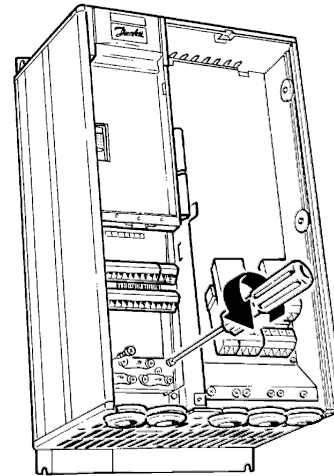

175ZA179.10

Cascade Controller Option

■ 3. Remove VLT Cassette and Ribbon Cables

- Lift control board cassette from bottom.

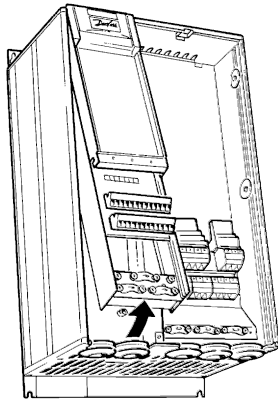

175ZA180.10

- Disconnect two ribbon cables from VLT control board.
- Unhinge cassette at top to remove.

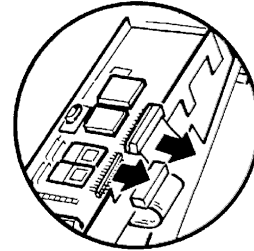

175ZT248.10

■ 4. Remove LCP Keypad Cradle

- Push tabs at side of LCP cradle to release clips.
- Pull out to disengage and lift cradle free.

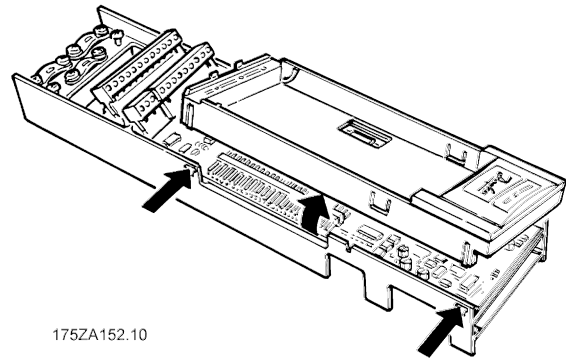

175ZA152.10

Cascade Controller Option

■ 5. Cascade Option Card Ribbon Cable Routing

- Route ribbon cables from cascade controller option card through slot at side of VLT control board cassette. Option card mounts with component side down.
- Feed plastic option card insulation pad through terminal opening in control board cassette.
- Insert edge of option card into slot (A) in side of cassette.
- Align opposite side of card with mounting holes (B) provided.

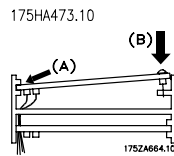
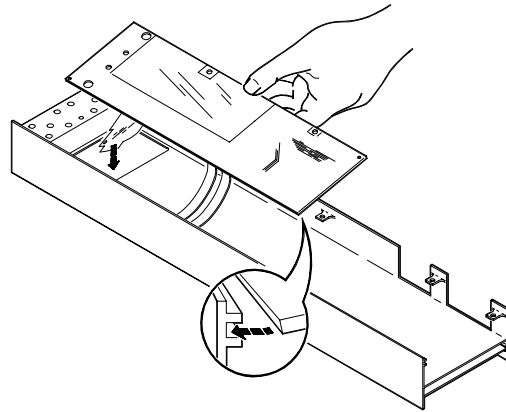

■ 6. Secure Option Card

- Secure option card to control board cassette with 3 self-tapping screws and washers provided. Use a Torx T-10 screw driver.

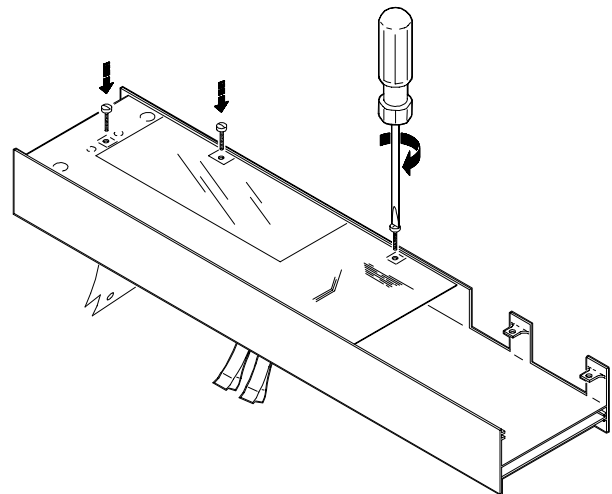

175HA474.10

■ 7. Connect Option Card Ribbon Cable to VLT Control Board

- Pull up collar (A) of control board ribbon cable socket.
- DO NOT remove blue insulation on end of option card ribbon cable. Insert ribbon cable into corresponding socket (B) on VLT control board and push collar closed. Be sure not to crimp ribbon cables.
- Repeat procedure for all ribbon cables.

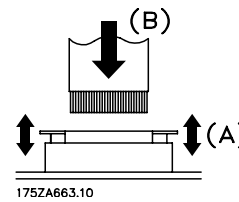
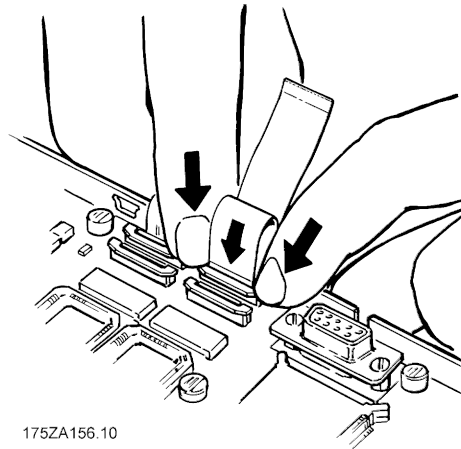

■ 8. Chassis Ground Connection

- Location of holes to mount grounding strips in VLT chassis can vary with drive configuration.
- When applicable, remove mounting screws located in chassis using Torx T-20 screw driver and save for reassembly. Otherwise, grounding strips attach with screws provided.

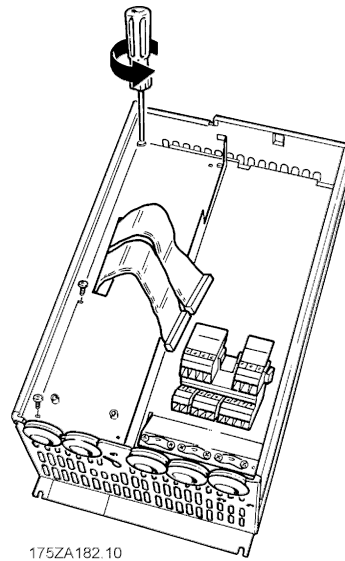

Installation and
Wiring Instructions

■ 9. Install Chassis Ground Connections

- Align ground strips over corresponding screw holes. (Strip with fewest contact points mounts on right side of chassis.)
- Replace screws removed and add additional screws provided, as necessary. Use a Torx T-20 screw driver.

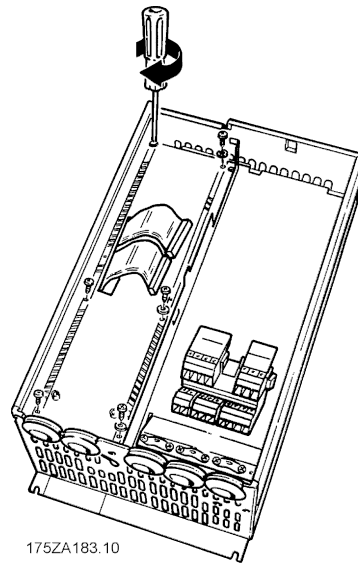

■ 10. Replace VLT Control Board Cassette

- Attach LCP keypad cradle to VLT control board cassette removed in step 4. Ensure not to crimp option card ribbon cables.
- Connect two ribbon cables to control board in corresponding connectors as removed in step 3.
- Hinge VLT cassette at top of VLT chassis and reposition into place. Use Torx T-20 screwdriver to fasten two captive screws. Ensure not to crimp control board ribbon cables.

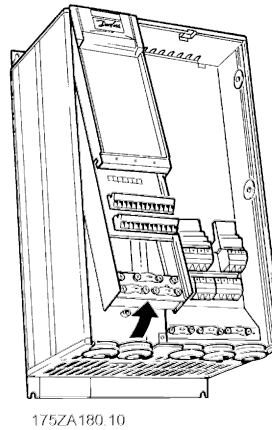

■ 11. Relay Output Connection

- Connect relay output cables to terminal blocks provided as required by application. (See wiring diagrams in this chapter.)
- Insert relay terminal blocks firmly into corresponding terminal sockets on control board.
- Secure relay wiring with bottom right wiring clamp and fasten.

Relay 6-9: A-B make, A-C break
 Max. 240 VAC, 2 A
 Max. cross-section: 1.5 mm² (28-16 AWG)
 Torque: 0.22 - 0.25 Nm

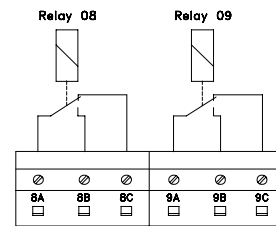
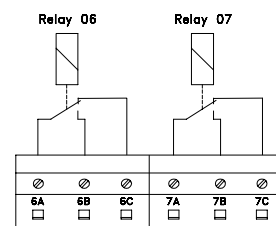

■ 12. Remove Wiring Clamp Mounting Fixture

- Option card insulation pad is designed to use top most cable wiring clamp screw hole for attaching.
- Use screw driver to remove top most wiring clamp.

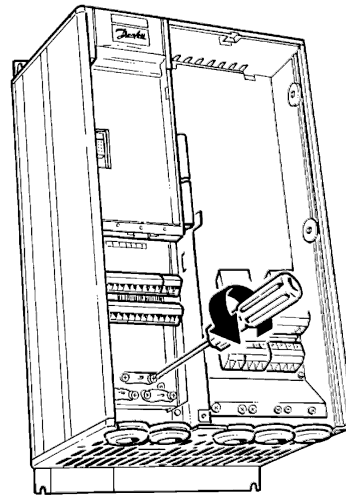

175ZA676.10

■ 13. Reconnect VLT Control Terminals and Secure Option Card Insulation Pad

- Reconnect VLT control terminals removed in step 2 by pressing firmly into corresponding terminal socket.
- Crease option card insulation pad flap and insert into slot in side of control card cassette.
- Attach insulation pad to top most clamp position with one screw from removed wiring clamp.
- Route VLT control terminal wiring through bottom left wiring clamp and fasten.

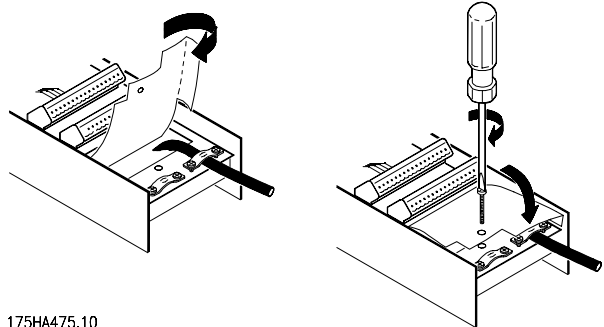

175HA475.10

■ 14. Final Reassembly

- Secure access cover to internal VLT components.
- Replace LCP keypad by positioning guide slots at bottom of cradle and snapping into place.
- Attach terminal protective cover by positioning guide pins at bottom of cover into control card cassette and snapping into place.

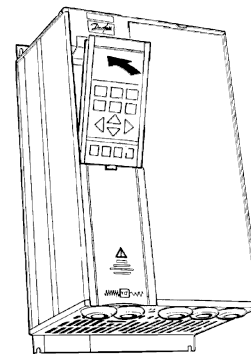

175ZA633.10

■ Transmitter wiring

Please refer to chapter 10, Feedback Transmitter Wiring.

Standard cascade control wiring diagram

The wiring diagram shows an example for a standard cascade control system with 4 fixed speed motors, a 4-20 mA pressure transmitter, and external safety interlock.

Power terminal connections

Control board terminal connections

Option card terminal connections

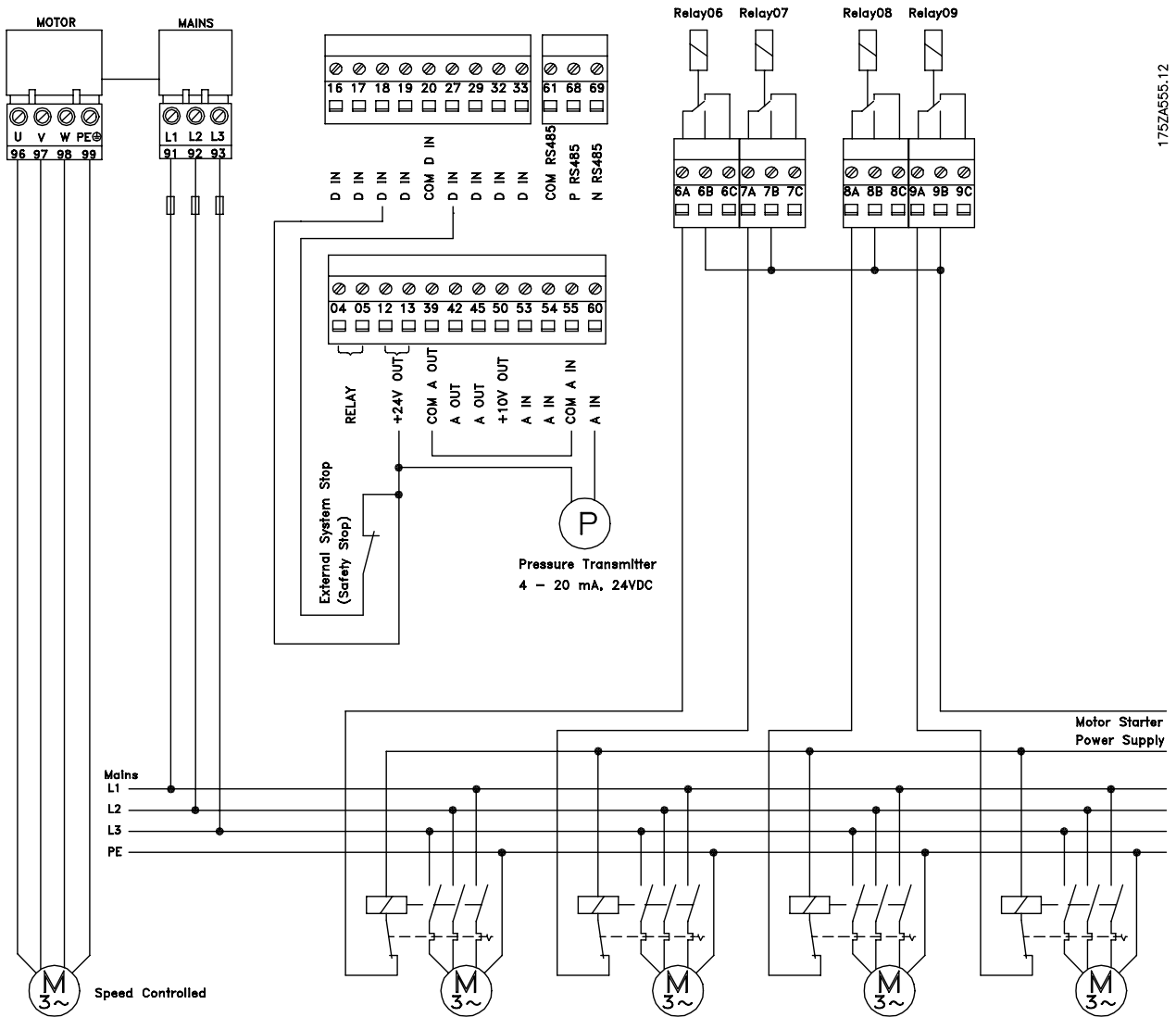

175ZA555.12

■ Optional Hand/Off/Auto Switch

Optional Hand/Off/Auto Switch

In standard cascade control mode, an optional Hand/Off/Auto switch on the constant speed motor starter is common. During normal operation, the switch is set to AUTO and the drive will signal automatic start and stop commands to the motor. The HAND position allows manual operation of the motor. The motor can be disabled by setting the switch to OFF. For a motor in the OFF position, the

cascade controller will try to start it by triggering its relay. Since no contribution will occur, the next pump will be switched on. The relay timer will, however, assume operation for a disabled motor. See Chapter 12, *Service Parameters*.

The diagram below provides wiring instructions for an optional Hand/Off/Auto switch.

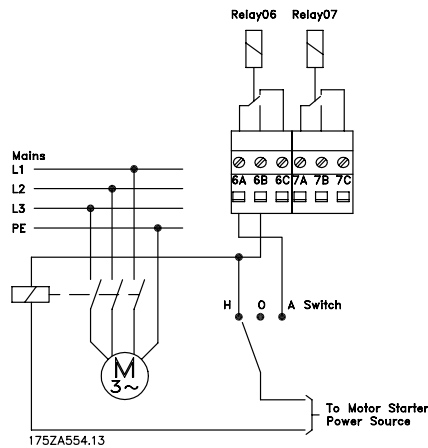

Lead Pump Alternation Wiring Diagram

Every pump must be fitted with a double power contactor with a safety mechanical interlock. The wiring of the system is shown in the diagrams below.

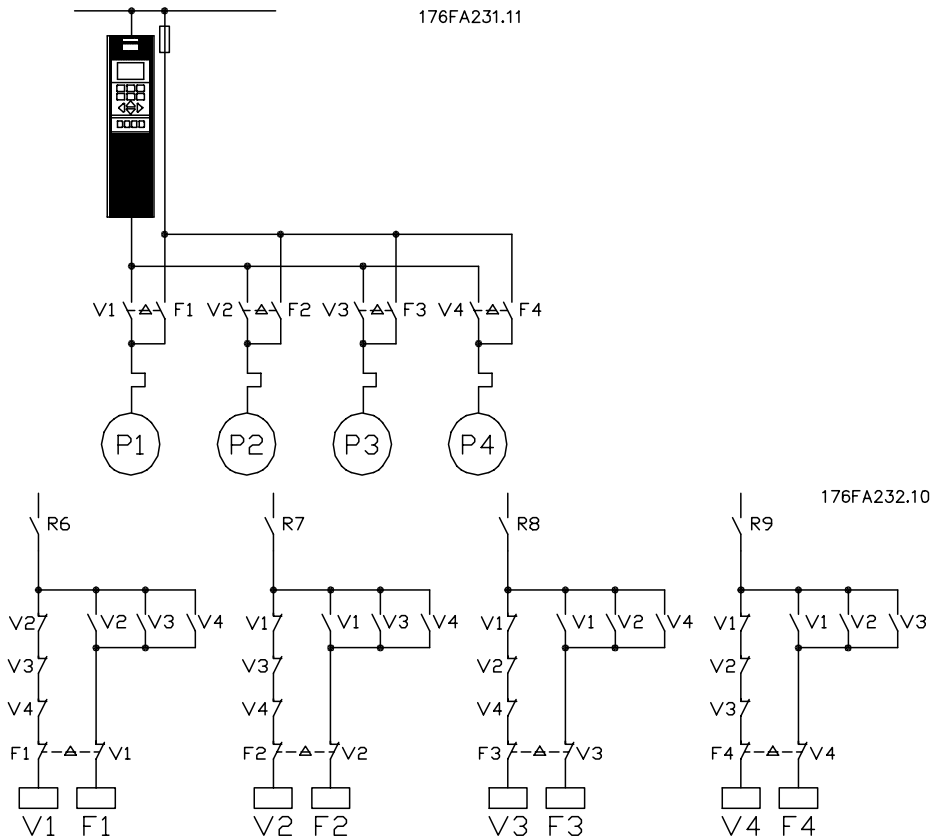

- Relays R6, R7, R8, and R9 are the Cascade Controller card relays
- When all relays are idle (OFF) the first relay ON sets the power switch corresponding to the pump controlled by the frequency converter. For example R6 set V1, i.e. P1 becomes the lead pump.
- V1 block F1 in off position though the mechanical interlock
- Auxiliaries NC contacts of V1 prevent V2, V3 and V4 activation
- The first fixed speed pump is P2 (through F2) by relay R7, then P3 (F3) by R8 and so on.
- When the timer reaches its preset value all pumps are switched off in the same order as switched on i.e. P4, P3, P2 and then P1
- The system restarts with R7 relay on which set pump P2 as the lead pump controlled by the VLT, then R8, R9, R6 (P3, P4, P1 running fixed speed on mains)

Cascade Controller Option

Master drive in master/slave control wiring diagram

The wiring diagram below shows an example of a Master drive in Master/Slave cascade control. The system demonstrates a 4-20 mA pressure transmitter,

an external safety interlock and four slave drives. The slave drive speed reference is provided from terminal 17 as a pulse signal. The relays on the option card are used for the Start/Stop command to the slave drives.

Power terminal connections

Control board terminal connections

Option card terminal connections

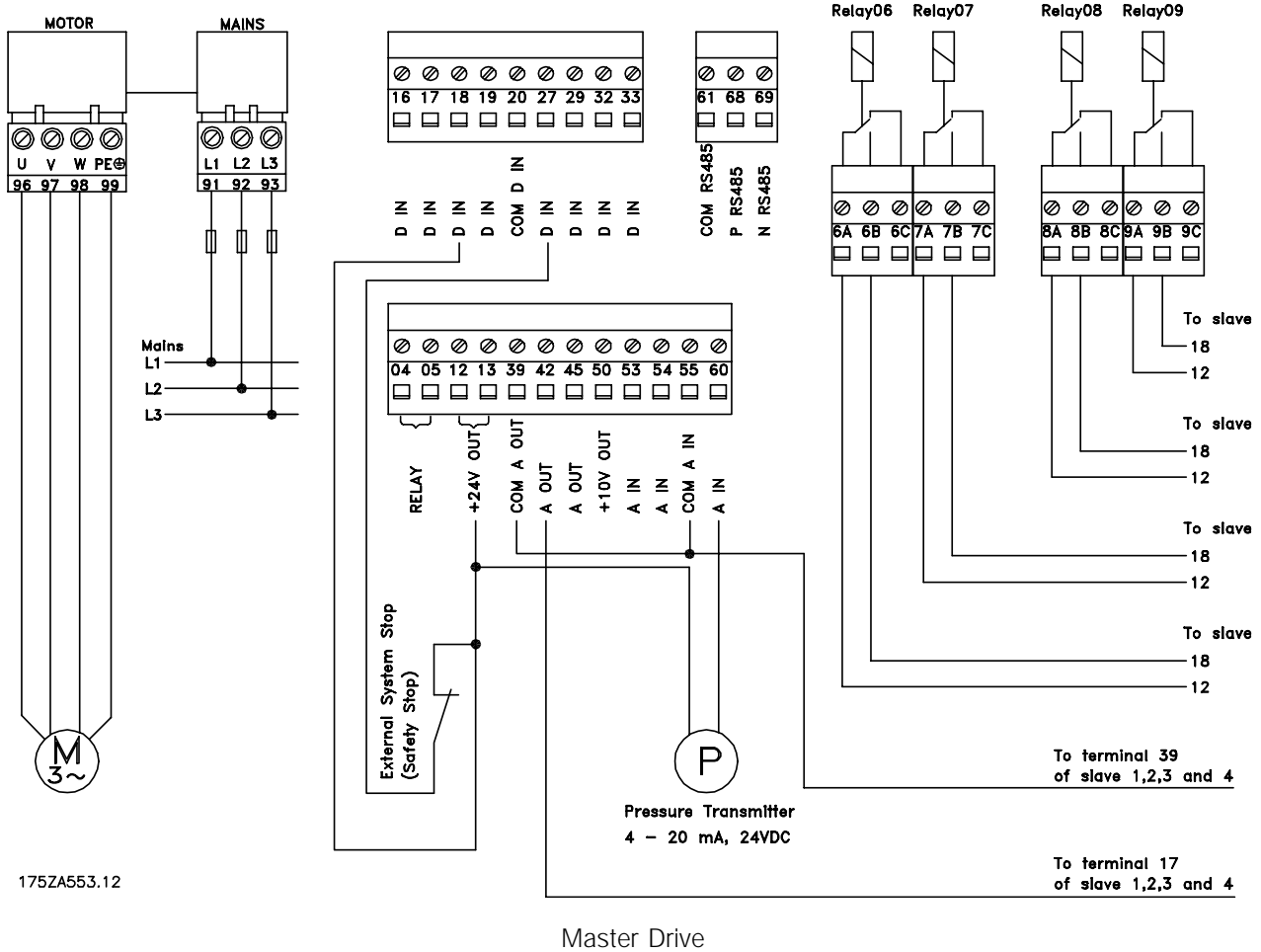

Installation and Wiring Instructions

■ Slave drive in master/slave control wiring diagram

Each slave drive is wired in the same way, receiving the Start/Stop command and a pulse speed reference from the master drive. The speed reference and its common are typically looped from Slave-to-Slave.

Power terminal connections

Control board terminal connections

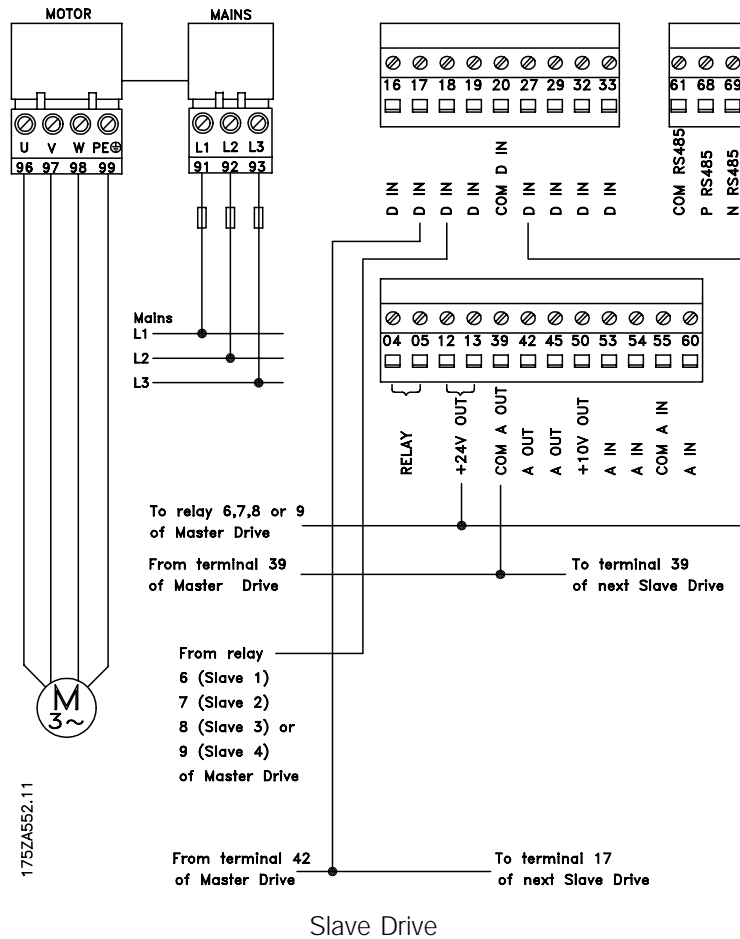

■ Changed Drive functions

■ Introduction

Installation of the Cascade Controller Option card into the frequency converter overrides some existing drive functions. Changes to the default parameter setting are shown in the tables below. Data entered into the drive parameters are used to program the drive and cascade controller for system operation. The modified parameter default settings make programming the cascade controller easier. See Chapter 5, *User Interface*, for instructions on programming drive parameters.

In addition, parameters that need to be programmed for cascade control operation are assembled sequentially in a new and expanded 44 item Quick Menu. Programming is simplified by following the Quick Menu items in sequence for either Standard cascade control or Master/Slave cascade control. The new Quick Menu is described in Chapter 6, *VLT Drive and Cascade Controller Card Setup*.

New options are also available to stop pumps or fans controlled in cascade operation. A summary of VLT changed functionality is presented in this chapter.

Changed Default Settings with the Cascade Controller Option Card

Parameter	Description	Previous default	New default
100	Configuration	Open loop	Closed loop
201	Minimum output freq.	0.0 Hz	40% of nominal frequency
205	Maximum reference	50/60 Hz	100%
206	Ramp-up time	Varies with unit	<i>See table below</i>
207	Ramp-down time	Varies with unit	<i>See table below</i>
304	Terminal 27 (digital input)	Safety interlock ¹ /Coasting stop inverse	Coasting stop, inverse
308	Terminal 53 (analog in V)	Reference	No operation
314	Terminal 60 (analog in A)	Reference	Feedback (4-20 mA)
318	Function after time out	No function	Stop (sequence stop)
417	Feedback Function	Maximum	Virtual Control Curve
427	PID lowpass filter time	0.01 sec.	0.20 sec.

VLT Type		Ramp Up (parameter 206)	Ramp Down(parameter 207)
8005/6002	8011/6011	1 sec.	1 sec.
8016/6016	8062/6062	3 sec.	2 sec.
8072/6072	8302/6272	5 sec.	3 sec.
8352/6352	8600/6550	8 sec.	5 sec.

¹ VLT 8000: Factory setting for US

Cascade Controller Option

■ Changed systemstop functions

Two stop functions are provided by the cascade controller option. One function quickly stops a system. The other stages off pumps in a sequence, allowing for a controlled pressure stop.



Do not use these functions as emergency stops. Some functions do not turn off all pumps.

Standard cascade control mode

Stop functions in Standard cascade control are described in the table below. In a sequenced stop, there is a one ramp-down time delay between each staging off of motors.

Standard Cascade Control	
Function	Description
OFF/STOP key	Provides a sequenced stop for all constant speed motors in opposite order as staged on. Controller decelerates its motor to a stop.
STOP via Terminals 16 and 17 (System Start parameters 300 and 301)	Controller decelerates its motor to a stop. With motor stopped, controller provides sequenced stop for constant speed motors.
STOP via Terminal 18 (Start parameter 302)	Constant speed motors continue to operate normally with feedback signal from drive. Controller decelerates its motor to a stop.
STOP via Terminal 27 (Coast Inverse parameter 304)	Constant speed motors stop immediately. Controller coasts its motor to a stop.
STOP via Terminal 27 (Safety Interlock parameter 304)	Constant speed motors stop immediately. Controller coasts its motor to a stop.



NB!:

Should the frequency converter trip for any reason, the cascade controller can continue operation with the remaining pumps. Only at live zero where par. 315 Live zero functionality is set to [STOP] or [STOP AND TRIP] or at warning 8 [DC UNDERVOLTAGE] all pumps will stop.

Master/Slave cascade control mode

Stop functions in Master/Slave cascade control are described in the table below.

Master/Slave Cascade Control	
Function	Description
OFF/STOP key	Provides a sequenced stop for all slave motors in opposite order as staged on. Master decelerates its motor to a stop.
STOP via Terminal 16 and 17 (System Start parameters 300 and 301)	Slave motors all stop together. Master decelerates its motor to a stop.
STOP via Terminal 18 (Start parameter 302)	Slave motors all stop together. Master decelerates its motor to a stop.
STOP via Terminal 27 (Coast Inverse parameter 304)	Slave motors all stop together. Master coasts its motor to a stop.
STOP via Terminal 27 (Safety Interlock parameter 304)	Slave motors all stop together. Master coasts its motor to a stop.



NB!:

Should the frequency converter trip for any reason, the cascade controller will cause the system to stop.

■ Serial communications (parameter 500)

The Danfoss FC protocol may be used only with MCT 10 software for programming and setting up drive and cascade controller parameters.

■ User Interface

■ How to use the LCP for programming

The combined display and keypad on the front of the frequency converter is called the Local Control Panel (LCP).

The LCP is the user interface to the frequency converter.

The LCP has several user functions: programming the frequency converter; displaying operational data, along with warnings and cautions; to reset the drive after a fault; and, in local control, to start/stop and control the speed of the drive.

■ Control keys for parameter setup

Each parameter determines an operational function the drive. Many parameters are used in combinations with others. The keys shown below are used for programming the drive by selecting from parameter options or entering data in the parameter, as applicable. The LCP keys are also used for selecting the data displayed during normal operation of the drive.

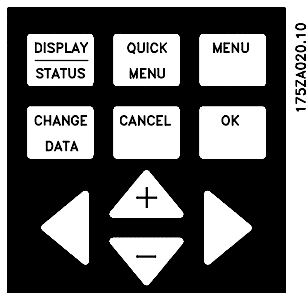

[DISPLAY/MODE] is used to change display modes or to return to the Display mode from either the Quick Menu or the Extend Menu mode.

[QUICK MENU] gives access to the programming parameters in the Quick Menu. These are the most commonly used parameters in setting up the drive functions.

[EXTEND MENU] gives access to all drive parameters, including Quick Menu items.

[CHANGE DATA] is used for changing a parameter setting selected in either the Extend Menu or the Quick Menu mode.

[CANCEL] is used if a change to a selected parameter is not to be carried out.

[OK] is used for confirming a change to a selected parameter.

[+/-] are used to scroll through parameters and for changing a selected parameter. These keys can also be used to change the drive speed as a function of the local reference. In addition, the keys are used in Display mode to switch between readouts.

[<>] are used when selecting a parameter group and for moving the cursor to the desired digit when changing numerical values.

■ Indicator lamps

At the bottom of the control panel are three indicator lamps: a red alarm lamp, a yellow warning lamp, and a green voltage (power on) lamp.

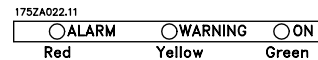

If pre-determined threshold values are exceeded, the alarm and/or warning lamp is activated, and a status or alarm text is displayed. The power-on light is activated when the frequency converter receives voltage.

■ Drive Control

Keys for control of the drive are described below.

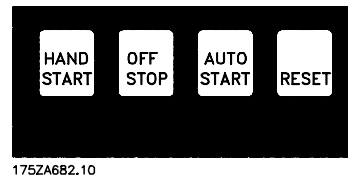

[HAND START] is used if the frequency converter is to be started and controlled from the LCP. The frequency converter will start the motor when [HAND START] is pressed.

NB!
 The motor will start when [HAND START] is activated if parameter 201, *Output frequency low limit*, is set to an output frequency greater than 0 Hz.

On the control terminals, the following control signals will still be active when [HAND START] is activated:

- Hand Start - Off Stop - Auto Start - Reset
- Safety interlock
- Coasting stop inverse
- Reversing

- Setup select lsb - Setup select msb
- Jog
- Run permissive
- Lock for data change
- Stop command from serial communication

[OFF/STOP] is used for stopping the connected motor in Hand or Auto mode. This key can be disabled in parameter 013. If the stop function is activated, the main display will flash.

[AUTO START] is used if the frequency converter is to be controlled through the control terminals. When a start signal is active on the control terminals and/or serial bus, the frequency converter drive will start.



NB!

Drive can start at anytime with a start signal through digital inputs. Digital inputs have higher priority than control keys [HAND START] and [AUTO START].

[RESET] is used for manually resetting the drive after a fault trip (alarm). In this case, the top line of the display will show TRIP (RESET). If the top line of the display shows TRIP (AUTO START), the drive will automatically restart. If the top line of the display shows TRIPLOCK (DISC. MAINS), input power to the drive must be removed before the trip can be reset.

body is removed if a stop command is given or if the output frequency falls below 0.01 Hz.

Warnings and alarms (fault trips) will also be displayed. During an alarm, ALARM and the alarm number is shown on the large display. An explanation is given in line 3 or in lines 3 and 4. For a warning, WARN. and the warning number is shown with an explanation in line 3 and/or 4. Both alarms and warnings cause the display to flash.



The list below gives the operating data options for the first and second line of the LCP display.

■ Display modes

In Auto operational mode, information is displayed in any of three programmable displays. Pressing the [DISPLAY MODE] key enters display mode and toggle between modes I and II. In Display mode, the [+] and [-] keys scroll through all data display options. When in Mode II, holding down the [DISPLAY MODE] key identifies the units the display is showing on the top line. Mode IV is available only in local Hand operation.

In normal operation, three data readouts can be shown on the first (top) line of the display. One readout is available for line 2 (the large display). Parameters 008, 009 and 010 select the data displayed on the top line. Parameter 007, *Large Display Readout*, selects the data displayed on line 2.

The list on the next page defines the operating data that can be selected for the display readouts. Line 4 (bottom line) automatically displays the operating status of the drive.

The active setup number and an arrow indicating the direction of motor rotation is shown on the right side of the large display. Clockwise indicates forward and counterclockwise indicates reverse. The arrow

Data Item:	Unit:
Resulting reference, %	[%]
Resulting reference, unit	[unit]
Frequency	[Hz]
% of maximum output frequency	[%]
Motor current	[A]
Power	[kW]
Power	Power [HP]
Output energy	[kWh]
Hours run	[hours]
User-defined readout	[unit]
Setpoint 1	[unit]
Setpoint 2	[unit]
Feedback 1	[unit]
Feedback 2	[unit]
Feedback	[unit]
Motor voltage	[V]
DC-link voltage	[V]
Thermal load on motor	[%]
Thermal load on VLT	[%]
Input status, digital input terminal 53	[binary code]
Input status, analog terminal 54	[V]
Input status, analog terminal 60	[mA]
Output status, relay status	[binary code]
Pulse reference	[Hz]
External reference	[%]
Heat sink temperature	[°C]
comm. option card warning	[HEX]
LCP display text	[HEX]
Status word	[HEX]
Control word	[HEX]
Alarm word	[HEX]
PID Output	[Hz]
PID Output	[%]

Three operating data values can be shown in the first display line and one in the large display line, programmed via parameters 007, 008, 009, and 010.

Display mode I

In Display mode I, the drive is in Auto mode with reference and control determined via the control terminals. Below is an example in which the drive is running in setup 1, in Auto mode, with a remote reference, and at an output frequency of 40 Hz.

The text in line 1, FREQUENCY, describes the meter shown in the large display. Line 2 (large display) shows the current output frequency (40.0

Hz), direction of rotation (reverse arrow), and active setup (1). Line 3 is blank. Line 4 is the status line and the information is automatically generated for display by the drive in response to its operation. It shows that the drive is in auto mode, with a remote reference, and that the motor is running.

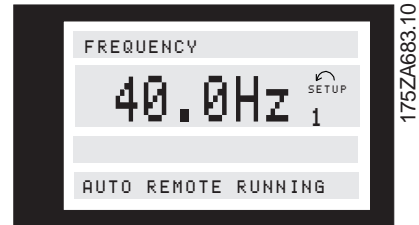

Status line (Line 4): Additional automatic displays for the drive status line are shown below.

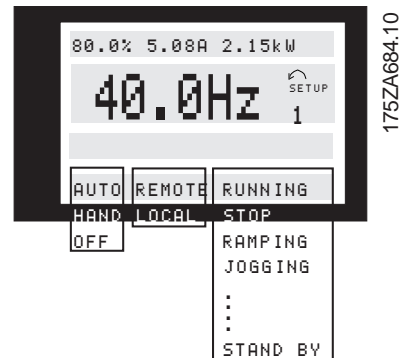

The left indicator on the status line displays the active control mode of the VLT drive. AUTO is displayed when control is via the control terminals. HAND indicates that control is local via the keys on the LCP. OFF indicates that the drive ignores all control commands and will not run.

The center part of the status line indicates the reference element that is active. REMOTE means that reference from the control terminals is active, while LOCAL indicates that the reference is determined via the [+] and [-] keys on the control panel.

The last part of line 4 indicates the drive's operational status, for example: RUNNING, STOP, or ALARM.

Display mode II

This display mode shows three operating data values in the top line programmed via parameters 007, 008, and 009. Pressing the [DISPLAY MODE] key toggles between Display modes I and II.

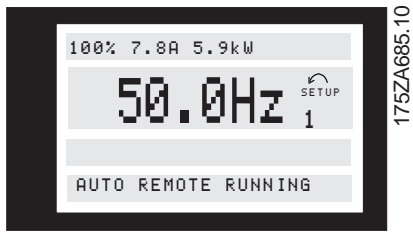

Display mode III

Press and hold the [DISPLAY MODE] key while in Mode II. Mode III is visible as long as the key is depressed. The top line changes to identify the data names and units displayed. Lines 2 and 4 are unchanged. When the key is released, the display returns to Mode II.

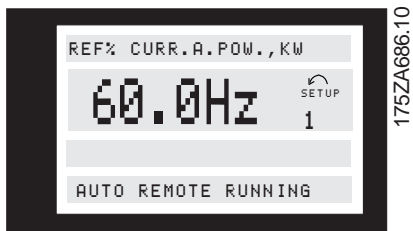

Display mode IV

This display mode is used for local operation, where the local speed reference is given from the keypad. In this display mode, the reference is determined via the [+] and [-] keys. Control is carried out through the bottom keys on the keypad. The first line indicates the required reference. The third line gives the relative value of the output frequency in the form of a bar graph in relation to the maximum frequency.

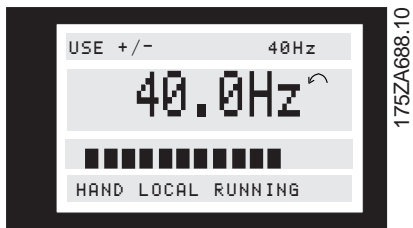

■ Changing data

Regardless of whether a parameter has been selected under the Quick Menu or the Extend Menu, the procedure for changing data is the same. Pressing the [CHANGE DATA] key gives access to changing the selected parameter. Line 3 displays the parameter number and title. The underlined function or number flashing in line 4 on the display is subject to change.

The procedure for changing data depends on whether the selected parameter represents a numerical data value or a function.

Changing numeric values

If the chosen parameter represents a number value, the flashing digit can be changed by means of the [+] and [-]

keys. Position the cursor by using the [<] and [>] keys, then change the data value using the [+] and [-] keys.

The selected digit is indicated by a flashing cursor. The bottom display line gives the data value that will be entered (saved) by pressing the [OK] button. Use [CANCEL] to ignore the change.

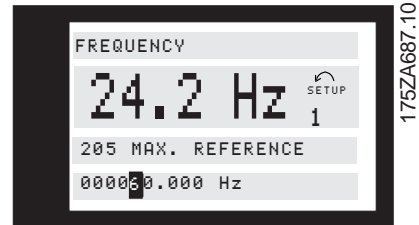

Changing functional values

If the selected parameter is a functional value, the selected text value can be changed by means of the [+] and [-] keys.

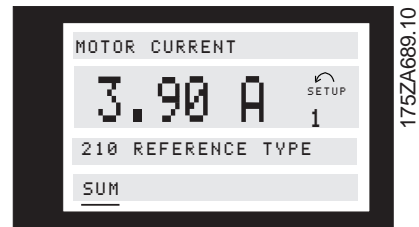

The functional value flashes until signing off by pressing the [OK] button. The functional value has then been selected. Use [CANCEL] to ignore the change.

Changing listed numeric values

A few parameters offer numeric lists of values that can be selected from or changed. This means that if the numeric value is not listed, a value may be entered using the procedure for changing numeric values. This applies to parameter 102, *Motor power*, parameter 103, *Motor voltage*, and parameter 104, *Motor frequency*.

■ Parameter setting procedure

Enter or change parameter data or settings as follows:

1. Press [Quick Menu] or [Extended Menu] key.
2. Use [+] and [-] keys to find parameter you choose to edit.
3. Press [Change Data] key.
4. Use [+] and [-] keys to select correct parameter setting. To move to a different digit within a numeric parameter, use < and > arrows. *Flashing cursor indicates digit selected to change.*
5. Press [Cancel] key to disregard change, or press [OK] key to accept change and enter new setting.

■ Example of how to change parameter data

Assume Quick Menu item 9 (parameter 206, *Ramp Up Time*) is set at 60 seconds. Change the ramp up time to 100 seconds as follows:

1. Press [Quick Menu] key.
2. Press [+] key until you reach Quick Menu item 9 of 35 (parameter 206), *Ramp Up Time*.
3. Press < key twice – hundreds digit will flash.
4. Press [+] key once to change hundreds digit to '1.'
5. Press > key once to move to tens digit.
6. Press [-] key until '6' counts down to '0' and setting for *Ramp Up Time* reads '100 s.'
7. Press [OK] key to enter new value.

■ Manual initialization

The drive can be initialized to return to factory default settings.

NB!  Initializing the drive will remove all values and settings entered into drive. Some factory default settings may be for European applications.

1. Remove AC power to drive.
2. Press and hold [DISPLAY MODE] + [CHANGE DATA] + [OK] keys down while at same time applying AC power to drive.
3. Release keys. The frequency converter reverts to factory setting.

It is also possible to carry out initialization via parameter 620, Operating mode, by selecting Initialize.

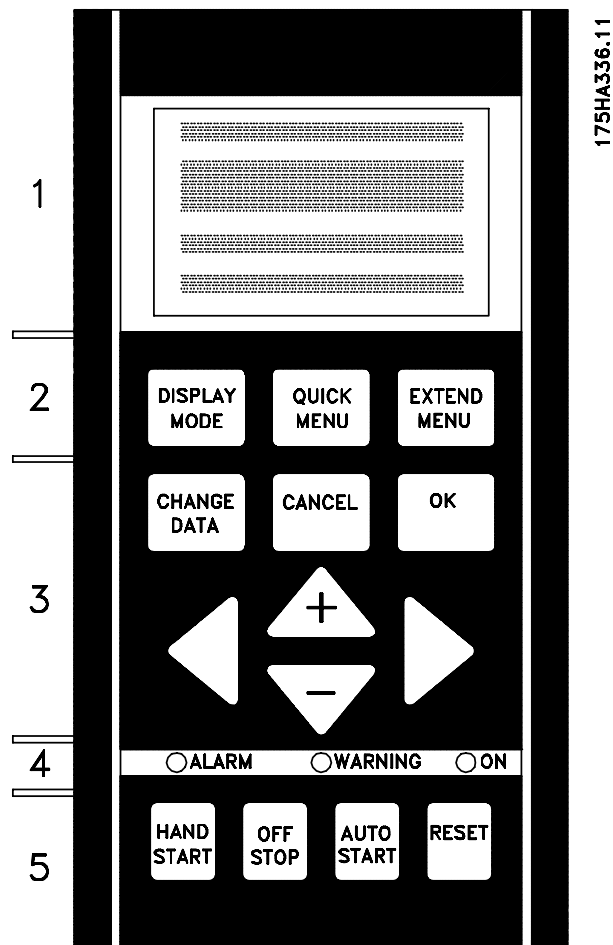

The following parameters are not reset when using manual initialization:

- 500, Protocol
- 600, Operating hours
- 601, Hours run
- 602, kWh counter
- 603, Number of power-ups
- 604, Number of overtemperatures
- 605, Number of overvoltages
- 724 - 737, Operating hours/counters

■ VLT Drive and Cascade Controller Setup

■ Introduction

A new quick menu list is activated when a cascade controller option card is installed in the frequency converter. The original 12 items are expanded to 44 quick menu items that allow programming additional drive and cascade controller functions. See Chapter 4, *Changed Drive Functions*.

The first 20 items on the new quick menu must be programmed in sequence for initial drive and cascade controller setup. (See block diagram.) These 20 items are common to both Standard cascade control mode and Master/Slave control mode. After initial setup is complete, additional quick menu items program the drive for the selected mode of operation. Those instructions are available in Chapter 7, *Standard Cascade Control Mode Setup* and Chapter 8, *Master/ Slave Control Mode Setup*.

Chapter 9, *System Optimization*, provides instructions for final adjustments to reach maximum drive and controller efficiency after system start up.

Items 002 - 006 are motor characteristics. In Standard cascade control mode, only the motor data from the variable speed motor run by the cascade controller are entered. In Master/Slave control, only data from the motor controlled by the Master drive are entered at this time. Items 007 - 019 are basic cascade controller settings used in either mode of operation. Item 20

selects the mode of operation for further setup. The Quick Menu Summary table on the next page describes the menu items.

The frequency converter has four independent setups that can be programmed. The initial programming in this chapter is stored as Setup 1. See *Alternative Programming* at the end of this chapter for instructions on using the drive's multi-setup capability.

Frequency converters delivered with the cascade controller option card already installed, or prepared for field installation, have been programmed with factory settings typical for operation. These settings may be satisfactory for initial start up of the system.

See Chapter 5, *Use Interface*, for instructions on programming the frequency converter.

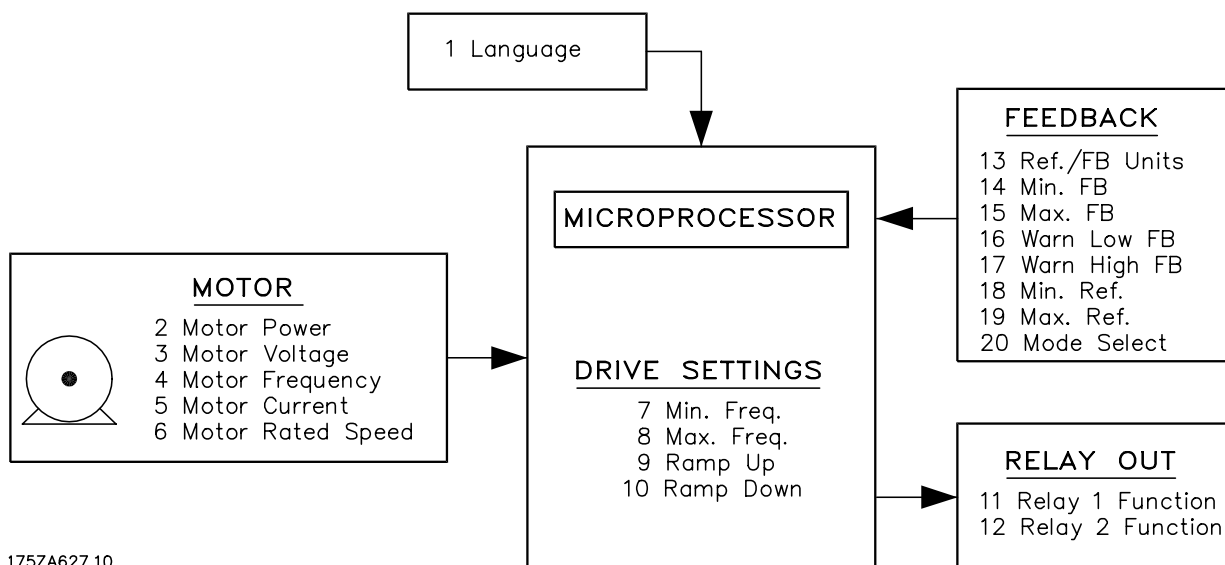

175ZA627.10

Cascade Controller Option

■ Quick Menu Summary

Quick Menu number	Parameter number	Name	Units	Range	Factory setting
Basic Drive Set Up parameters					
001	001	Language		10 languages	See VLT 6000 HVAC or VLT 8000 AQUA manuals.
002	102	Motor Power	KW/HP	1.1-450/1.5-600	
003	103	Motor Voltage	Volts	200 - 480	
004	104	Motor Frequency	Hz	50 / 60	
005	105	Motor Current	Amps	0-IVLT max	
006	106	Rated Motor Speed	RPM	0- f _{m,n} x 60	
007	201	Min. Frequency	Hz	0.0 -f _{max}	2/5 of f _{nom} (NEW)
008	202	Max. Frequency	Hz	F _{min} -120/1000	F _{nom} x 1.1 (NEW)
009	206	Ramp up time	Seconds	1-3600	See table above in 2.4.8
010	207	Ramp down time	Seconds	1-3600	
011	323	Relay 1 Output	Depending on choice		See VLT 6000 HVAC Manual.
012	326	Relay 2 Output			
Basic Set Up for Standard Cascade and Master/Slave.					
013	415	Closed loop units	Selected according to your process.		
014	413	Minimum Feedback			
015	414	Maximum Feedback			
016	227	Warning low Feedback	Units	-999,999.999- FB High	-999,999.999
017	228	Warning high Feedback	Units	FB low- 999,999.999	999,999.999
018	204	Ref.min.	Units	Min. feedback - Ref.max	0
019	205	Ref.max.	Units	Ref.min - Max. feedback	0
020	723	Operational Mode select	-	Standard / M/S	Standard Cascade
021	712	Pump combination		1 - 8	1
022	713	Staging BandW.	%	1.0 - 100.0	10.0
023	714	Destaging Delay	Sec.	0.0 - 3000	15
024	715	Staging Delay	Sec.	0.0 - 3000	15
025	716	Override BW	% of set point	2.0 - 100.0	20.0
026	717	Override Timer	Sec.	0.0 - 300	5
027	718	Staging frequency	% of f _{max}	0 - 100	90
028	741	Destaging frequency	% of f _{max}	0-100	10
029	418	Setpoint 1 (H0)	Bar (or equiv.)	Refmin - Refmax	0.000
030	419	Setpoint 2 (H1)	Bar (or equiv.)	Refmin - Refmax	0.000
031	721	Destage Timer	Timer Sec.	0.0 - 300 (301 = OFF)	15
032	722	Pump cycling		Enabled/Disabled	Enabled
033	319	Analog/digital outputs	-	[1] - [43]	F out 0...20mA
034	739	M/S Stage on frequencies	Hz	F min - F max	F min
035	740	M/S stage off frequencies	Hz	F min - F max	F max
036	750	Alternation time	Hrs	0-999	0
037	751	Elapsed alternation time	Hrs	0 - par. 750	0
038	752	Alternation register		1-4	1
039	753	Alternation restart delay	Sec.	0-60	5
PID Controller tuning					
040	420	Normal/Inverse control		Normal/Inverse	Normal mode
041	422	PID Start up frequency	Hz	F _{min} -f _{max}	0 Hz
042	427	PID Lowpass filter time	Sec.	0.01 – 10.00	1.00
043	423	PID Proportional Gain	Factor	0.00 – 10.0	0.01
044	424	PID Integrator time	Sec.	0.01 – 9999.0	OFF

Cascade Controller Option

■ Language

Quick Menu 001 Par. 001 Language

(LANGUAGE)

Value:

- ★English (ENGLISH)
- German (DEUTSCH)
- French (FRANCAIS)
- Danish (DANSK)
- Spanish (ESPAÑOL)
- Italian (ITALIANO)
- Swedish (SVENSKA)
- Dutch (NEDERLANDS)
- Portuguese (PORTUGUESA)
- Finnish (SUOMI)

Function:

This choice defines the language to be used on the display.

Description of choice:

Select the display language.



NB!:

It is important that the values set in parameters 102-106, *Motor nameplate data*, correspond to the nameplate data of the motor.

■ Motor nameplate data

Quick Menu 002 Par. 102 Motor power

(MOTOR POWER)

Value:

0.1/3 HP (0.25 KW)	[000.25]
0.5 HP (0.37 KW)	[000.37]
0.75 HP (0.55 KW)	[000.55]
1.0 HP (0.75 KW)	[000.75]
1.5 HP (1.10 KW)	[001.10]
2 HP (1.50 KW)	[001.50]
3 HP (2.20 KW)	[002.20]
4 HP (3.00 KW)	[003.00]
5 HP (4.00 KW)	[004.00]
7.5 HP (5.50 KW)	[005.50]
10 HP (7.50 KW)	[007.50]
15 HP (11.00 KW)	[011.00]
20 HP (15.00 KW)	[015.00]
25 HP (18.50 KW)	[018.50]
30 HP (22.00 KW)	[022.00]
40 HP (30.00 KW)	[030.00]
50 HP (37.00 KW)	[037.00]
60 HP (45.00 KW)	[045.00]
75 HP (55.00 KW)	[055.00]
100 HP (75.00 KW)	[075.00]
125 HP (90.00 KW)	[090.00]
150 HP (110.00 KW)	[110.00]
200 HP (132.00 KW)	[132.00]

250 HP (160.00 KW)	[160.00]
300 HP (200.00 KW)	[200.00]
350 HP (250.00 KW)	[250.00]
400 HP (300.00 KW)	[300.00]
450 HP (315.00 KW)	[315.00]
500 HP (355.00 KW)	[355.00]
600 HP (400.00 KW)	[400.00]

★Depends on the unit

Function:

This sets the power value that corresponds to the nameplate power of the motor. The default setting is the full rating of the drive. The drive can operate motors undersized by up to four ratings below the full rating of the drive or oversized by one rating.

Description of choice:

Select a value that equals the nameplate data on the motor. tage

Quick Menu 003 Par. 103 Motor voltage

(MOTOR VOLTAGE)

Value:

200 V	[200]
208 V	[208]
220 V	[220]
230 V	[230]
240 V	[240]
380 V	[380]
400 V	[400]
415 V	[400]
440 V	[440]
460 V	[460]
480 V	[480]
500 V	[500]

★Depends on motor

Function:

This is where the rated motor voltage is selected.

Description of choice:

Select a value that equals the nameplate data on the motor, regardless of the AC input voltage of the frequency converter.

Quick Menu 004 Par. 104 Motor frequency

(MOTOR FREQUENCY)

Value:

50 Hz	★ 60
60 Hz	

Cascade Controller Option

Function:

This is where the rated motor frequency is selected.

Description of choice:

Select a value that equals the nameplate data on the motor.

Quick Menu 005 Par. 105 Motor current (MOTOR CURRENT)

Value:

0.01 - Drive rating ★ Depends on motor

Function:

The rated motor current in amps forms part of the frequency converter calculations for torque and motor thermal protection.

Description of choice:

Set a value that equals the nameplate data on the motor.



NB!:

It is important to enter the correct value, since this forms part of the VVC+ control feature.

Quick Menu 006 Par. 106 Rated motor speed (MOTOR NOM. SPEED)

Value:

100 - 60000 rpm
★ Depends on parameter 102, *Motor power*

Function:

This is where the value is set that corresponds to the rated motor speed found on the nameplate data.

Description of choice:

Set a value that corresponds to the motor nameplate data.



NB!:

It is important to set the correct value, since this forms part of the VVC+ control feature.

The maximum value equals frequency x 60. Frequency is set in parameter 104, *Motor frequency*.

Quick Menu 007 Par. 201 Output frequency low limit (MIN. FREQUENCY)

Value:

0.0 - Parameter 202 setting ★ 0.0 HZ

Function:

This is where to select the minimum output frequency. The drive will be unable to run continuously below this value in any mode.

Description of choice:

Set a value from 0.0 Hz to the *Output frequency high limit* set in Quick Menu item 008 (parameter 202).

Quick Menu 008 Par. 202 Output frequency high limit (MAX. FREQUENCY)

Value:

Para 201 setting - Para 200 limit ★ 60 Hz

Function:

In this parameter, a maximum output frequency can be selected that corresponds with the maximum motor speed. The drive will not be able to run continuously at an output frequency above this value in any mode.



NB!:

Set the output frequency high limit to 60 Hz for US applications. The output frequency of the frequency converter can never assume a value higher than 1/10 of the switching frequency (parameter 407, *Switching frequency*).

Description of choice:

Enter a value between the low frequency limit, set in Quick Menu item 07 (parameter 201), and the frequency range limit, set in parameter 200.

Quick Menu 009 Par. 206 Ramp-up time (RAMP UP TIME)

Value:

1 - 3600 sec. ★ Depends on unit

Function:

The ramp-up time is the acceleration time from 0 Hz to the rated motor frequency (parameter 104, *Motor frequency*). It is assumed that the output current does not reach the current limit (set in parameter 215, *Current limit*). This determines the maximum acceleration rate for all modes of operation.

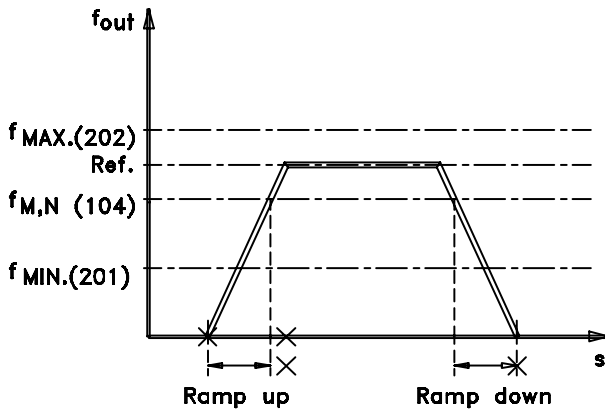

175HA334.10

Description of choice:

Set the desired ramp-up time. Too long of a ramp up time can cause sluggish drive operation. Too short of a ramp up time can cause the drive to go into current limit during acceleration or cause unacceptable torque pulses in the controlled system.

Quick Menu 010 Par. 207 Ramp-down time (RAMP DOWN TIME)

Value:

1 - 3600 sec.. ★ Depends on unit

Function:

The ramp-down time is the deceleration time from the rated motor frequency (parameter 104, *Motor frequency*) to 0 Hz. This ramp-down time may be automatically extended to prevent an overvoltage trip if the load regenerates to the drive. This determines the maximum deceleration rate for all modes of operation.

Description of choice:

Set the desired ramp-down time. Too long of a ramp down can cause sluggish operation. Too short of a ramp down can cause the drive to trip off due to high DC bus voltage or cause unacceptable torque pulses in the controlled system.

Relay outputs

Relay outputs 1 and 2 can be used to give the present drive status or a warning.

If the output is used as a voltage output (0-10 V), a pull-down resistor of 500Ω should be fitted to terminal 39 (common for analogue/digital outputs. See chapter 10 for additional detail).

If the output is used as a current output, the resulting impedance of the connected equipment should not exceed 500 W.

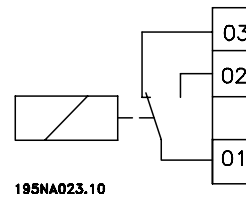

195NA023.10

Relay 1

1 - 3 break, 1 - 2 make Max. 240 VAC, 2 Amp. The relay is with the main and motor terminals.

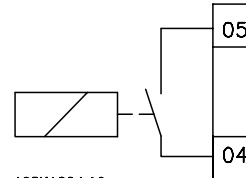

195NA024.10

Relay 2

4 - 5 make Max. 50 VAC, 1 A, 60 VA. Max. 75 VDC, 1 A, 30 W. The relay is on the control card.

Quick Menu 011 Par. 323 Output relay 1 (RELAY 1 FUNCTION)

Value:

29 optional settings ★ NO ALARM

Function:

This output activates relay switch 01. This 240 volt, Form C relay can be used for status and warnings. There are 29 optional settings. It is generally programmed to provide a remote alarm indication.

No Alarm is the default setting. This indicates the drive is operating properly and the contact is closed. The contact opens to indicate an alarm when there is a fault condition or when the drive loses power. Terminal wires 1 and 3 are wired together.

Alarm is selected when a loss of power should not cause an alarm indication. Wire terminals 1 and 2 together.

See the *VLT 6000 Operating Instructions MG60AXYY* or *VLT 8000 Operating Instructions MG80AXYY* respectively, for a detailed list of relay options.

Description of choice:

Select relay 1 function.

Cascade Controller Option

Quick Menu 012 Par. 326 Output relay 2

(RELAY 2 FUNCTION)

Value:

29 optional settings ★ RUNNING

Function:

This output activates relay switch 02. This low voltage relay is generally programmed to provide a remote run indication. There are 29 optional settings.

Running makes this relay close when the drive is running. This is the default setting.

Description of choice:

Select relay 2 function.

Quick Menu 013 Par. 415 Units relating to closed loop

(REF. / FDBK. UNIT)

Value:

No unit	[0]
★%	[1]
rpm	[2]
ppm	[3]
pulse/s	[4]
l/s	[5]
l/min	[6]
l/h	[7]
kg/s	[8]
kg/min	[9]
kg/h	[10]
m ³ /s	[11]
m ³ /min	[12]
m ³ /h	[13]
m/s	[14]
mbar	[15]
bar	[16]
Pa	[17]
kPa	[18]
mVS	[19]
KW	[20]
°C	[21]
GPM	[22]
gal/s	[23]
gal/min	[24]
gal/h	[25]
lb/s	[26]
lb/min	[27]
lb/h	[28]
CFM	[29]
ft ³ /s	[30]
ft ³ /min	[31]

ft ³ /h	[32]
ft/s	[33]
in wg	[34]
ft wg	[35]
PSI	[36]
lb/in ²	[37]
HP	[38]
°F	[39]

Function:

This unit will be used for the reading in the Display mode and as a unit for *Minimum / Maximum Feedback*, *Minimum / Maximum Reference*, *Warning Feedback High/Low* and for the *H1*, *H0* and the calculated *Hmx* parameter settings/readings.

Description of choice:

Select the unit for the reference/feedback signal.

Quick Menu 014 Par. 413 Minimum feedback (MIN. FEEDBACK)

Value:

-999,999.999 - FB_{MAX} ★ 0.000

Function:

Parameters 413, *Minimum feedback* and 414, *Maximum feedback* are used to scale the feedback signal ensuring that it shows the feedback signal proportionally to the signal at the input.

Description of choice:

Set the value to be shown on the display when the feedback signal is at its minimum value.

Quick Menu 015 Par. 414 Maximum feedback (MAX. FEEDBACK)

Value:

FB_{MIN} - 999,999.999 ★ 100.000

Function:

Parameters 413, *Minimum feedback* and 414, *Maximum feedback* are used to scale the feedback signal ensuring that it shows the feedback signal proportionally to the signal at the input.

Description of choice:

Set the value to be shown on the display when the feedback signal is at its maximum value.

Cascade Controller Option

Quick Menu 016 Par. 227 Warning: Low feedback (WARN LOW FDBK)

Value:

-999,999.999 - FB_{HIGH} (parameter 228)
★ -999.999,999

Function:

If the feedback signal is below the limit programmed in this parameter, the display will show a flashing FEEDBACK LOW.

The warning functions in parameters 221-228 are not active during ramp up after a start command, ramp down after a stop command or while stopped. The warning functions are activated when the output frequency has reached the resulting reference. The signal output can be programmed to generate a warning signal via terminal 42 or 45 or via the relay output.

In *Closed loop*, the unit for the feedback is programmed in parameter 415, *Units related to closed loop*.

Description of choice:

Set the desired value within the feedback range between parameter 413, *Minimum Feedback* and parameter 414, *Maximum Feedback*.

Quick Menu 017 Par. 228 Warning High feedback (WARN. HIGH FDBK)

Value:

FB_{Low} (parameter 227) - 999,999.999
★ -999.999,999

Function:

If the feedback signal is above the limit programmed in this parameter, the display will show a flashing FEEDBACK HIGH.

The warning functions in parameters 221-228 are not active during ramp-up after a start command, ramp-down after a stop command or while stop-ped. The warning functions are activated when the output frequency has reached the resulting reference. The signal outputs can be programmed to generate a warning signal via terminal 42 or 45 and via the relay outputs.

In *Closed loop*, the unit for the feedback is programmed in parameter 415 *Units related to closed loop*.

Description of choice:

Set the desired value within the feedback range between parameter 413, *Minimum Feedback*, and parameter 414, *Maximum Feedback*.

Quick Menu 018 Par. 204 Minimum reference (MIN. REFERENCE)

Value:

Parameter 100 *Configuration = Closed loop* [1].
-Par.413 *Minimum feedback*
- par.205 *Ref_{MAX}* ★ -999.999,999

Function:

The *Minimum Reference* sets the minimum value of the sum of all references. If *Closed loop* has been selected in parameter 100, *Configuration*, the minimum reference is limited by parameter 413, *Minimum Feedback*. Minimum reference is ignored when the local reference is active. In this case, minimum reference is determined by parameter 201, *Minimum Frequency*.

Description of choice:

Set the *Minimum Reference*, which is the lowest reference value that can be set for the drive. The unit for this reference is set in parameter 415.

Quick Menu 019 Par. 205 Maximum reference (MAX. REFERENCE)

Value:

Par. 204 *Ref_{MIN}*
- par. 414 *Maximum feedback* ★ 50.000 Hz

Function:

The *Maximum reference* gives the maximum value that can be assumed by the sum of all references. The *Maximum Reference* is limited to be with the settings of Parameter 414 *Maximum Feedback*. The *Maximum reference* is ignored when the local reference is active (parameter 203 *Reference site*).

Description of choice:

Set the *Maximum reference*, which is the highest reference value that can be set for the drive.

Quick Menu 020 Par. 723 Mode Select (MODE SELECT)

Value:

Standard Control ★ Master/Slave
Master/Slave Control

Function:

Standard cascade control mode operation is a system consisting of one adjustable speed pump and up to four constant speed pumps. Master/Slave cascade control mode operation is for a system using variable speed pumps controlled by a Master drive.



NB!:

Set the correct control option. Improper setting may result in system damage, operational errors, or wasted energy.

Description of choice:

Select *Standard Control* for operating the cascade controller option card in Standard control mode.
Select *Master/Slave Control* for operating the cascade controller option card in Master/Slave control mode.

■ Alternate programming

Setup configuration and copying parameters

The frequency converter has four parameter setups that can be programmed. Each setup acts independently in controlling the frequency converter. An example application would be programming different setups for day/night or summer/winter operation. Any of the four setups can be used.

The setup is selected in Extended Menu parameter 002, *Active Setup*, for programming and operation. Setups are changed manually by switching between active setups in parameter 002. It is also possible to change setups through digital inputs or serial communication by selecting *Multi-Setup* in parameter 002 and providing an external signal.

The number of the active setup selected is shown on the keypad display under *Setup* in the second line of the display.

The Extended Menu is accessed by pressing the [EXTEND. MENU] key on the LCP keypad.

A short cut to programming more than one setup is possible by using Extended Menu parameter 003, *Setup Copy*. This enables copying one setup to another. After an active setup has been programmed and copied, just those parameters unique to the other setups need be changed.

All setups can be transferred from one frequency converter to another (in the same frequency converter series) by using the frequency converter's removeable keypad. Extended Menu parameter 004, *LCP Copy*, allows this function. First, upload all parameter values to the keypad. The keypad can then be removed and plugged into another frequency converter where all parameter values can be downloaded. If motor or drive sizes differ, *Download Power-independent Parameters* can be selected in parameter 004 to omit downloading motor and current dependent data.

Extended Menu Par. 002 Active Setup (ACTIVE SETUP)

Value:	
Factory Setup (FACTORY SETUP)	[0]
★Setup 1 (SETUP 1)	[1]
Setup 2 (SETUP 2)	[2]
Setup 3 (SETUP 3)	[3]
Setup 4 (SETUP 4)	[4]
Multi-Setup (MULTI SETUP)	[5]

Function:
This parameter defines the setup number that controls the drive. All parameters can be programmed in four

individual parameter setups: Setup 1, Setup 2, Setup 3 and Setup 4. There is also a pre-programmed read-only setup, called the Factory Setup.

Description of choice:

Factory Setup contains the parameter values preset at the factory. This setup can be used as a data source if the other setups are to be returned to a known state. *Setups 1 through 4* are four individual setups that can be programmed and selected as required. *Multi-Setup* is used if remote switching between different setups is required. Terminals 16, 17, 29, 32, 33 and the serial communication port can be used for switching between setups.

Extended Menu Extended Par. 003 Setup Copy (SETUP COPY)

Value:	
★No copying (NO COPY)	[0]
Copy active Setup to Setup 1 (COPY TO SETUP 1)	[1]
Copy active Setup to Setup 2 (COPY TO SETUP 2)	[2]
Copy active Setup to Setup 3 (COPY TO SETUP 3)	[3]
Copy active Setup to Setup 4 (COPY TO SETUP 4)	[4]
Copy active Setup to All (COPY TO ALL)	[5]

Function:

A copy is made from the active setup selected in parameter 002, *Active Setup*, to the setup or setups selected here.



NB!:

Copying is only possible when drive is stopped.

Description of choice:

The copying starts when the required copying function has been selected and the [OK] key pressed. The display indicates when copying is in progress.

Extended Menu Par. 004 LCP Copy (LCP COPY)

Value:	
★No copying (NO COPY)	[0]
Upload all parameters (UPLOAD ALL PARAMET.)	[1]
Download all parameters	

- (DOWNLOAD ALL PARAM.) [2]
Download power-independent parameters
- (DOWNLOAD SIZE INDEP.) [3]

Function:

This parameter is used to copy all parameter setups to or from the Local Control Panel (LCP) keypad. It can be used to store a backup copy of all parameters in the LCP or to copy all setups from one drive to another.

Description of choice:

Select *Upload all parameters* to copy all parameter values from the drive to the LCP.

Select *Download all parameters* to copy all parameter values from the LCP to the drive on which the keypad is mounted.

Select *Download power-independent parameters* if only the power-independent parameters are to be downloaded. This allows the parameters from one drive to be easily copied to another drive of a different size. Settings in parameters 102, 103, 104, 105, 106, 215, 221, and 222 are not downloaded using this function.

**NB!:**

Copying is only possible when drive is stopped.

■ Standard Cascade Controller Setup

■ Introduction

In standard cascade control, a frequency converter with the cascade option card controls a motor in response to system feedback signals while staging additional constant speed motors on and off. By varying the speed of the initial motor, variable speed control is provided for the system.

The motors can be of equal or differing sizes. The controller offers a selection of eight pre-defined pump combinations (see parameter 712).

A de-stage timer takes effect in standard control mode when the drive runs continuously at minimum speed with one or more constant speed motors running. The de-stage timer is programmable to avoid frequent staging on and off of the constant speed motors.

Although pump applications are highlighted in this chapter, the procedures and settings are nearly identical for other applications. The feedback process setup described, assumes that a pressure feedback signal is measured at the outlet of the pumps.

Programming instructions:

Instructions for programming Quick Menu items 1-20 are presented in Chapter 5, *VLT Drive and Cascade Controller Card Setup*. Parameters 1-20 must be programmed before programming Standard cascade control options.

The instructions in this chapter describe procedures for programming the frequency converter for standard cascade control mode operation. The Quick Menu simplifies setup since the 44 parameters are programmed in sequence. Procedures for programming are in the following order:

Initial Setup: Quick Menu items 1-20

Step 1: Standard control mode programming

Step 2: Optimization of the process regulator

Alternate Programming

Optimizing the process regulator is performed after system start up. The procedures are described in Chapter 9, *System Optimization*.

Sensor placement:

Best efficiency is attained when the pressure transmitter is placed at the farthest significant load in the system. This setup allows measurement of actual system performance. If this is not practical, the pressure transmitter is usually placed close to the discharge of the pumps.

The cascade controller uses the feedback to estimate the setpoint required at various rates of flow. Setpoint 1 is the minimum pressure required when the system is running with only the frequency converter operating at full speed. Setpoint 2 is the maximum pressure required when the system is running with all pumps at full capacity. A theoretical value calculates pressure loss in the system under minimum and maximum loads. The controller adjusts the loading based upon the number of pumps in operation.

When the pressure transmitter is placed at the farthest significant load in the system, common in HVAC applications, see alternative ways of programming the cascade controller described in *Alternate Programming* at the end of this chapter.

General information on how to program the frequency converter through the local control panel keypad are presented in Chapter 4, *User Interface*.

■ Lead Pump Alternation

The programming of the lead pump alternation function is basically done as for the standard cascade controller. A few parameters have been added and a few parameters have been changed. For further information please see section *Programming of lead pump alternation function*.

Cascade Controller Option

Initial Setup

Instructions for programming Quick Menu items 1-20 are presented in Chapter 5, *VLT Drive and Cascade Controller Card Setup*. Parameters 1-20 must be programmed before programming additional options described below.

Quick Menu 021 Par. 712 Motor Pump Combinations (PUMP COMBINATION)

Value:

(See options in table below)

Function:

The combinations of pumps and their rated capacities are selected in this parameter. The lead pump (or fan) with the cascade control option must have a capacity of 100% and its speed is controlled by the frequency converter. This enables the highest accuracy in regulation of the system. In Standard cascade control mode, additional pumps can be either 100%, 200% or 300% relative to the frequency converter driven pump.

Motor Pump Combinations

Value:

Additional Constant Speed Pumps Operated by Cascade Control

Display Option	100% Capacity	200% Capacity	300% Capacity
R6 @100%	1 pump controlled by relay 6		
R6, R7 @100%	2 pumps controlled by relays 6, 7		
R6-R8 @100%	3 pumps controlled by relays 6, 7, 8		
R6-R9 @100%	4 pumps controlled by relays 6, 7, 8, 9		
R6 @100%, R7 @200%	1 pump controlled by relay 6	1 pump controlled by relay 7	
R6 @100%, R7, R8 @200%	1 pump controlled by relay 6	2 pumps controlled by relays 7, 8	
R6, R7 @100%, R8 @300%	2 pumps controlled by relays 6, 7		1 pump controlled by relay 8
R6, R7 @100%, R8, R9 @300%	2 pumps controlled by relays 6, 7		2 pumps controlled by relays 8, 9

Description of choice:

Select the pump combination and capacities from the choices offered.

175ZA644.10

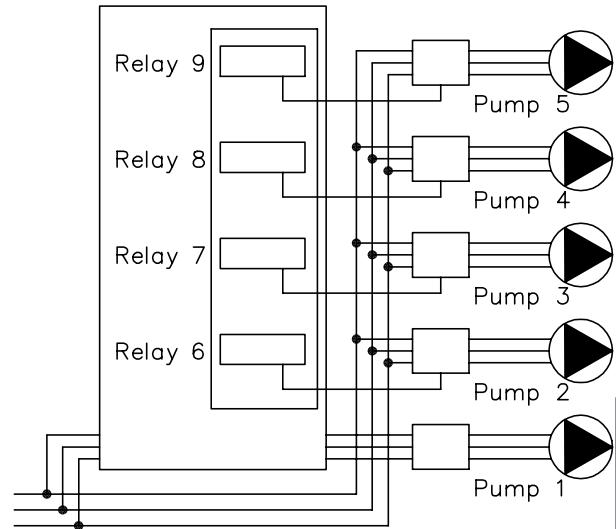

Standard Cascade Controller Setup

Cascade Controller Option

**Quick Menu 022 Par. 713 Staging Bandwidth %
(STAGING BANDW%)**

Value:
1 - 100% ★ 10%

Function:
In cascade control systems, to avoid frequent switching of fixed speed pumps, the desired system pressure is typically kept within a bandwidth rather than at a constant level. The staging bandwidth (SBW) is programmed as a percentage of the setpoint (desired pressure). For example, if the setpoint is 5 bar and the SBW set at 10%, a system pressure between 4.5 and 5.5 bar is tolerated. No staging or destaging will occur within this bandwidth.

Description of choice:
Set the staging bandwidth percentage to accommodate system pressure fluctuation.

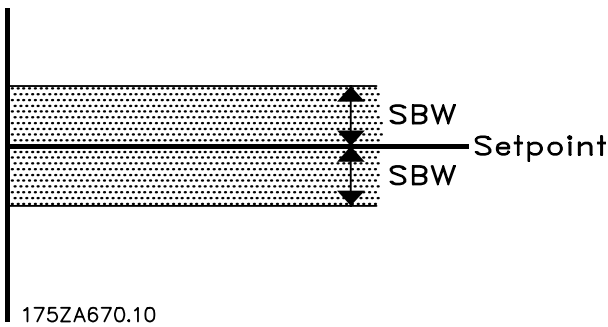

NB!  Should the frequency converter trip for any reason, the cascade controller can continue operation with the remaining C/S pumps or fans. It is recommended, however, that the user considers a wider bandwidth for parameter 716, Override Bandwidth. Otherwise, unnecessary staging could occur.

**Quick Menu 023 Par. 714 SBW staging off time
(DESTAGING DELAY)**

Value:
0 - 3000 sec. ★ 30 sec.

Function:
Immediate destaging of a fixed speed pump is not desirable when a momentary pressure increase in the system that exceeds the staging bandwidth (SBW). Destaging is delayed by the length of time programmed. If the pressure decreases to within the SBW before the timer has elapsed, the timer is reset.

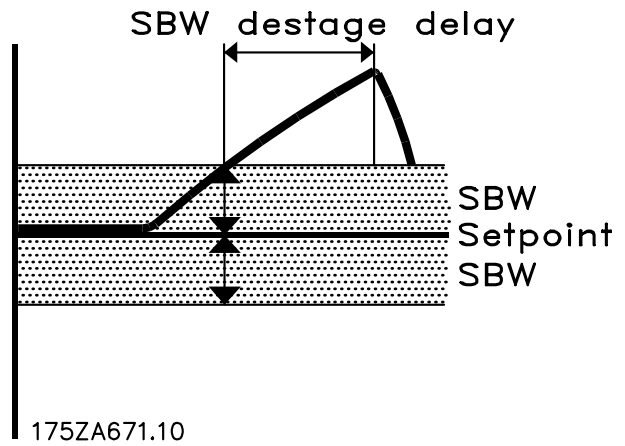

Description of choice:
Set the staging bandwidth off time delay. A delay time of 30 seconds (factory setting) is sufficient in most systems. When encountering frequent staging, add to the delay time.

**Quick Menu 024 Par. 715 SBW staging on time
(STAGING DELAY)**

Value:
0 - 3000 sec. ★ 30 sec.

Function:
Immediate staging of a fixed speed pump is not desirable when a momentary pressure drop in the system that exceeds the staging bandwidth (SBW). Staging on is delayed by the length of time programmed. If the pressure increases to within the SBW before the timer has elapsed, the timer is reset.

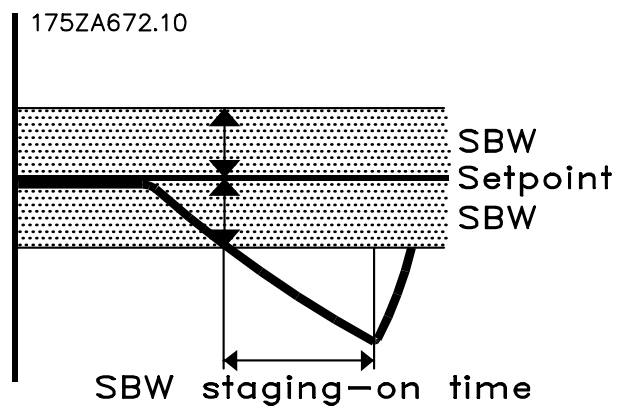

Description of choice:
Set the staging on time delay. A delay time of 30 seconds (factory setting) is sufficient in most systems. When encountering frequent staging, decrease delay time.

Cascade Controller Option

**Quick Menu 025 Par. 716 Override bandwidth
(OVERRIDE BANDW%)**

Value:
2 - 100 % (100 = OFF) ★ 100 = OFF

Function:
When a large and quick change in the system demand (such as a sudden water demand), the system pressure rapidly changes and an immediate staging or destaging of a fixed speed pump becomes necessary to match the requirement. The override bandwidth (OBW) is programmed to override the staging/destaging timer for immediate response. The override bandwidth is a percentage of the setpoint and defines the feedback (pressure) at which the timers (set in parameters 714, 715) are overridden. For example, if the setpoint is 5 bar and the override is set to 20%, the low limit is 4 bar and the high limit 6 bar.

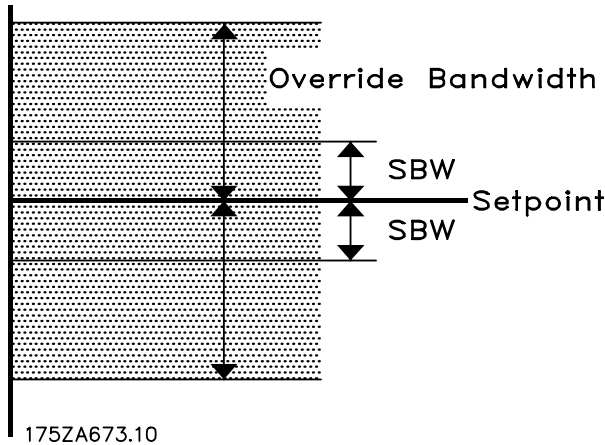

Description of choice:
The OBW must always be programmed to a higher value than the staging bandwidth (SBW) set in parameter 713. Setting the OBW too close to the SBW could defeat the purpose with frequent staging at momentary pressure changes. Setting the OBW too high might lead to unacceptably high or low pressure in the system while the SBW timers are running. The value can be optimized with increased familiarity with the system. See parameter 717, *Override Bandwidth Timer*.

Commissioning the Cascade Controller

To avoid unintended staging during the commissioning phase and fine tuning of the controller, initially leave the OBW at the factory setting of 100%. When the fine tuning is completed, the OBW should be set to the desired value. A good initial value may be 10%.

**Quick Menu 026 Par. 717 Override Bandw. timer
(OVERRIDE TIMER)**

Value:
0 - 300 sec. ★ 10 sec.

Function:
Staging a fixed speed pump creates a momentary pressure peak in the system, which might exceed the override bandwidth (OBW). It is not desirable to destage a pump in response to a staging pressure peak. The override bandwidth timer can be programmed to prevent staging until the system pressure has stabilized and normal control established.

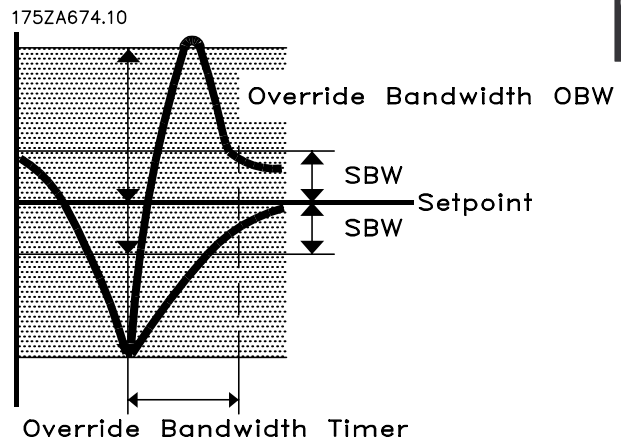

Description of choice:
Set the timer to a value that allows the system to stabilize after staging. The 10 second factory setting is appropriate in most applications. In highly dynamic systems, a shorter time might be desirable.

**Quick Menu 027 Par. 718 Staging frequency
(STD STAGE FRQ %)**

Value:
0 - 100 % of F_{max} ★ 90%

Function:
The adjustable speed pump typically runs at maximum speed when staging on an additional fixed speed pump to match the system demand.

Standard Cascade
Controller Setup

Cascade Controller Option

The instant effect of the fixed speed pump creates a momentary overpressurization until the adjustable speed pump decelerates. This is undesirable in most situations. To avoid this, this drive can be programmed to decelerate to a staging frequency before starting the fixed speed pump.

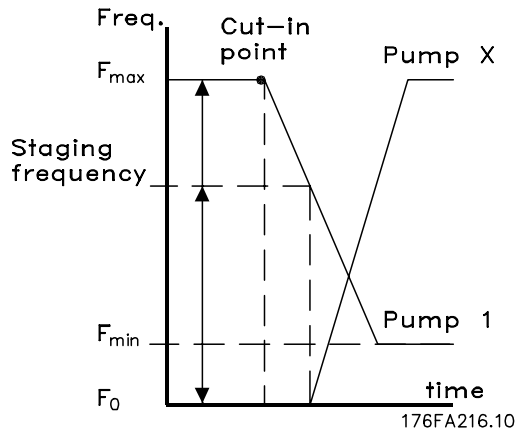

NB!:

Ensure that the staging frequency is set within the minimum frequency and maximum set in parameters 201 and 202.

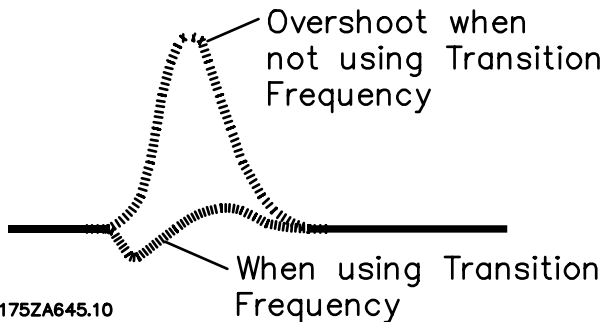

Description of choice:

Adjust the staging frequency to the best compromise to prevent momentary pressure overshoot and a pressure drop during transition. A very low value for the staging frequency might cause the check valve at the discharge of a variable speed pump to close during the transition, which could add pressure in the system. Ensure that the staging frequency setting allows the check valve to remain open.

Quick Menu 028 Par. 741 Destaging frequency (STD DESTAGE FRQ)

Value:
0 - 100 % F_{max} ☆ 10%

Function:
The lead pump (pump 1 in the figure) typically runs at minimum speed when destaging occurs. Turning off a fixed speed pump (pump X in the

figure) creates a momentary pressure drop until the lead pump decelerates. To avoid this, the drive will accelerate to a Destaging frequency before turning off the fixed speed pump.

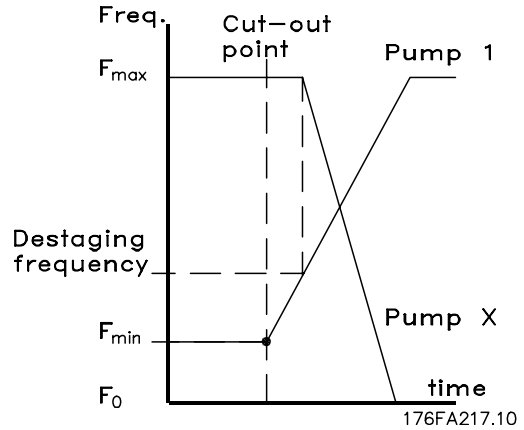

Description of choice:

Adjust the Destaging frequency to the best compromise to prevent momentary pressure drop and over-pressurization during transition. A very low value for the destaging frequency might cause the check valve at the discharge of the lead pump to close during the transition, which could add pressure in the system. Ensure that the Destaging frequency setting allows the check valve to remain open.



NB!:

Ensure that the Destaging frequency is set within the Minimum and Maximum frequency in par. 201 and 202.

Cascade Controller Option

Quick Menu 029 Par. 418 Setpoint 1

(SETPOINT 1)

Value:

Feedback Min. to Feedback Max. ★ 0.000

Function:

The default feedback process is used when a pressure feedback signal is measured at the outlet of the pumps. The cascade controller uses the feedback to estimate the setpoint required at various rates of flow. All other reference signals are ignored. Setpoint 1 is the minimum pressure required when the system is running with only the frequency converter operating at full speed. Setpoint 1 is a theoretical value that the cascade controller uses as an internal reference to calculate pressure loss in the system under minimum load. The controller adjusts the internal reference based upon the number of pumps in operation.

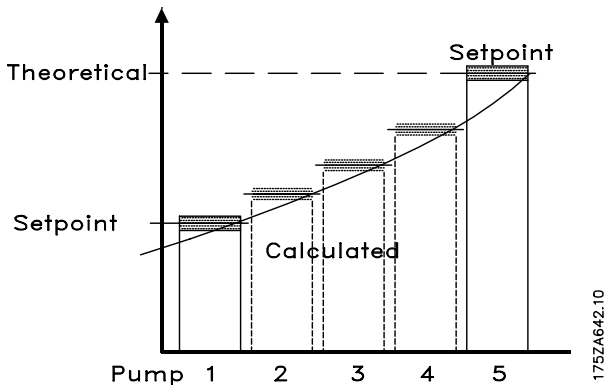

The range is determined by Quick Menu item 14 (parameter 413, *Minimum Feedback*) and Quick Menu item 015 (parameter 414, *Maximum Feedback*). When the pressure feedback signal originates at the far end of the system, the frequency converter does not need to compensate for system pressure changes due to flow. For this system configuration, or for two setpoint PID control, see *Alternative Programming* at the end of this chapter.

Description of choice:

Set the desired feedback minimum within the programmed minimum and maximum in Quick Menu items 014 and 015. The process unit is selected in Quick menu item 013, *Process Units*.



NB!:

Factory setting is for a single 4 - 20 mA current signal transmitter for process feedback. In all other cases, see instructions in Chapter 10, *Feedback Transmitter Wiring*.

Quick Menu 030 Par. 419 Setpoint 2

(SETPOINT 2)

Value:

Feedback Min. to Feedback Max. ★ 0.000

Function:

The default feedback process is used when a pressure feedback signal is measured at the outlet of the pumps. The cascade controller uses the feedback to estimate the setpoint required at various rates of flow. All other reference signals are ignored. Setpoint 2 is the maximum pressure required when the system is running with all pumps at full capacity. A theoretical value calculates pressure loss in the system under maximum load. The controller adjusts the loading based upon the number of pumps in operation.

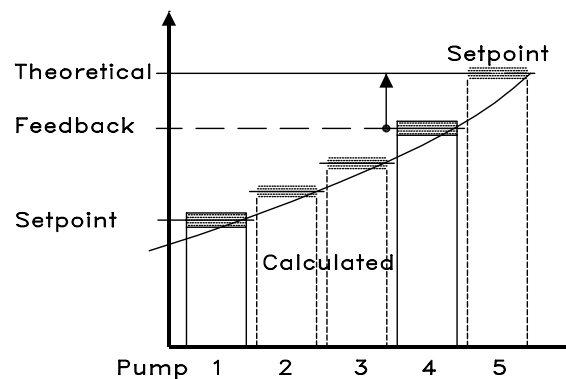

The range is determined by Quick Menu item 014 (parameter 413, *Minimum Feedback*) and Quick Menu item 05 (parameter 414, *Maximum Feedback*).

When the pressure feedback signal originates at the far end of the system, the drive does not need to compensate for system pressure changes due to flow. For this system configuration, or for two setpoint PID control, or for water pumping systems where the feedback signal is measured across the outlet of the pumps, see *Alternative Programming* at the end of this chapter.

Description of choice:

Set the desired feedback maximum within the programmed minimum and maximum in Quick Menu items 014 and 015. The process unit is selected in Quick menu item 013, *Process Units*. In a water supply system with little leakage, the difference between Setpoint 1 (set in Quick Menu item 028) and Setpoint 2 is typically around 10% to 15%.

Cascade Controller Option

Quick Menu 031 Par. 721 De-stage timer

(DESTAGE TIME)

Value:

0 - 300 sec. (301= OFF) ★ 15 sec.

Function:

The de-stage timer starts when the adjustable speed pump is running a minimum speed with one or more constant speed pumps in operation and system requirements satisfied. In this situation, the adjustable speed pump contributes little to the system. When the programmed value of the timer expires, a fixed speed pump is destaged and the adjustable speed pump accelerated to maintain system requirement. This saves energy and avoids dead head water circulation within the adjustable speed pump.

Description of choice:

Set the de-stage timer interval. When sleep mode is activated, ensure the interval is set lower or equal to the value of the sleep mode timer (parameter 403).

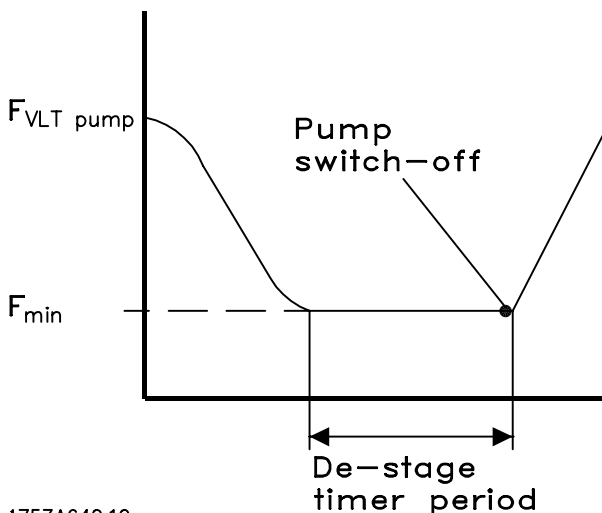

175ZA640.10



NB!:

Sleep mode activates when the adjustable speed pump is the only pump running. To turn off the de-stage timer, turn off sleep mode first. Set parameter 403, *Sleep Mode* to 301 seconds (off), then parameter 721, *De-stage Timer* to 301 seconds (off).

Quick Menu 032 Par. 722 Pump cycling

(PUMPCYCLING)

Value:

Enabled - Disabled ★ Enabled

Function:

To achieve equal hours of operation in the constant speed pumps, pump use can be cycled. Timers on the relay outputs (relays 6, 7, 8, and 9) monitor the running hours of each pump. In staging on, the

relay (pump) with the least hours is switched on. In destaging, the relay (pump) with the most hours is switched off. Not operating a pump over long time periods can create corrosion concerns.

If cycling is disabled, the controller follows the fixed pattern of relay activation (6, 7, 8 and 9) regardless of the running hour counters. Destaging is in the reverse order.

Description of choice:

Choose whether to disable or enable the function.

Quick Menu 040 Par. 420 PID normal/inverse control

(PID NOR/INV. CTRL)

Value:

★ Normal (NORMAL) [0]
Inverse (INVERSE) [1]

Function:

This determines how the drive's PID controller responds to a difference between the setpoint and feedback. *Normal* is when the drive is to reduce the output frequency as the feedback signal increases. *Inverse* is when the drive is to increase the output frequency as the feedback signal increases.

Description of choice:

Select the PID controller response option.

■ Programming of the Lead Pump Alternation Function

The standard cascade controller parameters and the following parameters 750 - 753 are to be programmed.

Select "Standard" in quick menu 020, par. 723 Operational mode select.

Parameter 722 Pump cycling (quick menu 032) now includes Enabled - Indexed alternation, i.e.

- [0] Disabled (DISABLE)
- [1] Enabled - Standard mode (ENABLE)
- [2] Enabled - Indexed alternation (ENABLE INDEXED) where you choose [2].

Parameter 712 Motor pump combinations (quick menu 021) are now limited to:

Cascade Controller Option

Pump combination	Relays used	Comment
2 pumps @ 100%	Relay 6, 7.	PUMP#1 (at R6) and PUMP#2 (at R7).
3 pumps @ 100%	Relay 6, 7, 8.	PUMP#1 (at R6), PUMP#2 (at R7) and PUMP#3 (at R8).
4 pumps @ 100%	Relay 6, 7, 8, 9.	PUMP#1 (at R6), PUMP#2 (at R7), PUMP#3 (at R8) and PUMP#4 (at R9).

And the following parameters are to be set:

Quick Menu 036 Par. 750 Alternation Time (ALTERNATION TIME)

Value:

0-999 ★ 0 Hours

(0 = Only manual)

Function:

This is the time period between automatic alternation of the lead pump, e.g. alternation every 48 hours. When alternation occurs, all pumps shut down and a new lead pump is connected.

Description of choice:

Set the desired value in hours. "0" corresponds to manual operation.

Quick Menu 037 Par. 751 Elapsed Alternation Time (ELAPSED ALT TIME)

Value:

0-par. 750 Alternation time ★ 0 Hours

Function:

The timer counts the elapsed time since last alternation, and can be used during commissioning. E.g. if the time when programming the frequency converter is 9.30 (am) and you want the lead pump alternation to take place at 23.00 (11 pm) counting the hours back to 23.00 (11 pm) gives you the elapsed hours, i.e. 10,5 hours. Lead pump alternation occurs when the "elapsed alternation time" is equal to "alternation time".

Description of choice:

Set the desired time.

Quick Menu 038 Par. 752 Alternation Register (ALT. REGISTER)

Value:

1-4 ★ 1

Function:

It is possible to manually choose the desired lead pump for the next "alternation time" period. When selecting a number between 1 and 4 the elapsed alternation timer will be reset. As soon as the chosen lead-pump has been in operation for the alternation time set in par. 750, automatic alternation will take over. When manually changing lead pump, all pumps will shut down like for automatic alternation before a new lead pump is connected.



NB!

Can only be changed when the system is running.

Description of choice:

Select which pump you want to be the lead pump.

Quick Menu 039 Par. 753 Alternation Restart Delay (ALT. RESTART DEL)

Value:

0-60 ★ 5 sec.

Function:

The controller makes sure, that a "new" lead pump is not started up before the "old" lead pump is stopped. The time in this parameter sets the delay from when the "old" lead pump is completely stopped until the "new" one must be started up.

Description of choice:

Set the desired time.

Sleep mode:

The sleep mode function also works in the indexed alternation mode. If the alternation occurs when the frequency converter is in sleep mode, the lead pump is changed according to the alternation procedure. The frequency converter continues with a new lead pump but stays in the sleep mode.

Cascade Controller Option

■ Alternate programming

In water supply systems, it is often impractical to place a pressure sensor at the far end of the system. In HVAC and other applications, however, it is often possible to place the pressure sensor(s) at the farthest significant load and measure actual pressure in the system. In these cases, the cascade option can use the drive's PID controller to respond to system changes as programmed. Pumps or fans are staged on and off in response to the system feedback signal.

The most common setup for feedback response is with a single transmitter located at the farthest significant load in the system. Programming the cascade controller option in this manner is described below. It is also possible for the PID to accept two feedback signals, making two-zone regulation available. For two feedback control, and for additional setting options, see the *VLT 6000 Operating Instructions MG60AXYY/VLT 8000 Operating Instructions MG80AXYY*, respectively.

Setup for feedback response is with a single transmitter located at the farthest significant load in the system requires programming parameter 417, *Feedback Function*, and parameter 418, *Setpoint 1*. Parameter 417, *Feedback Function*, is only accessible through the Extended Menu. The Extended Menu is accessed by pressing the [EXTEND. MENU] key on the drive control panel. Parameter 418 may be accessed through either the Extended Menu or as item 29 in the Quick Menu.

EXTENDED MENU Par. 417 Feedback Function (2 FEEDBACK, CALC.)

Value:

- Minimum (MINIMUM)
- Maximum (MAXIMUM)
- Sum (SUM)
- Difference (DIFFERENCE)
- Average (AVERAGE)
- Two-zone minimum (2 ZONE MIN)
- Two-zone maximum (2 ZONE MAX)
- ★Virtual Control Curve (VIRTUAL CTRL CURVE)
 - Feedback 1 Only (FEEDBACK 1 ONLY)
 - Feedback 2 Only (FEEDBACK 2 ONLY)

Function:

This parameter sets the calculation method whenever a system feedback signal is used, or when two feedback signals (Setpoint 1 and Setpoint 2) are used.

Description of choice:

Set the feedback function to *Maximum* for the drive to use Setpoint 1 as the maximum reference signal for control.

Quick Menu 029 Par. 418 Setpoint 1 (SETPOINT 1)

Value:

Feedback Min. to Feedback Max. ★ 0.000

Function:

Setpoint 1 is used to provide the setpoint reference for one setpoint PID control or for the setpoint for zone 1 in two setpoint PID control. All other reference signals are ignored.

Description of choice:

Set the required value the system is to maintain during normal operation. The value must be between the minimum and maximum values set in Quick Menu items 14 and 15 (parameter 413, *Minimum Feedback*, and parameter 414, *Maximum Feedback*). Setpoint 2, Quick Menu item 30, is not used in one feedback signal applications.

■ Master/Slave Cascade Control Setup

■ Introduction

In Master/Slave cascade control operation, the frequency converter with the cascade control option card is the Master. The Master drive controls the speed and staging on or off of up to four additional adjustable speed drives. The Master drive exports a pulse signal or analog speed signal through its output relays to the slave drives. It is recommended that a pulse signal be used for minimum electrical noise and for precise drive control.

The Master drive and the slave drives are programmed for different operation, although many parameters are set the same. The Master drive is programmed for closed loop operation and responds to system feedback signals to meet the needs of the system. The slave drives are programmed for open loop operation and receive a variable speed signal and stop/start commands from the Master drive.

Although pump applications are highlighted in this chapter, the procedures and settings are nearly identical for other applications. The feedback process setup described, assumes that a pressure feedback signal is measured at the outlet of the pumps.

Programming instructions:

Instructions for programming Quick Menu items 1-20 are presented in Chapter 6, *VLT Drive and Cascade Controller Card Setup*. Parameters 1-20 must be programmed before programming Master/Slave cascade control options.

The instructions in this chapter describe procedures for programming both the Master and slave drives for Master/Slave cascade control mode. Procedures for programming are in the following order:

Initial Setup: Quick Menu items 1-20

Step 1: Master drive programming

Step 2: Slave drive programming

Step 3: Optimization of the process regulator

Alternate Programming

Optimizing the process regulator is performed after system start up. The procedures are described in Chapter 9, *System Optimization*.

Best efficiency:

Danfoss has available the Multiple Unit Staging Efficiency Calculator (MUSEC), a free software program available on the Danfoss website. By entering pump

and system data, MUSEC provides the programmer with Master drive on and off staging frequencies for each pump at optimal efficiency. For a free download, go to www.danfoss.com/drives.

Sensor placement:

Best efficiency is attained when the pressure transmitter is placed at the farthest significant load in the system. This setup allows measurement of actual system performance. If this is not practical, the pressure transmitter is usually placed close to the discharge of the pumps.

The default feedback process described for setup in this chapter is used when a pressure feedback signal is measured at the outlet of the pumps. The cascade controller uses the feedback to estimate the setpoint required at various rates of flow. Setpoint 1 is the minimum pressure required when the system is running with only the adjustable frequency drive operating at full speed. Setpoint 2 is the maximum pressure required when the system is running with all pumps at full capacity. A theoretical value calculates pressure loss in the system under minimum and maximum loads. The controller adjusts the loading based upon the number of pumps in operation.

When the pressure transmitter is placed at the farthest significant load in the system, common in HVAC applications, see alternative ways of programming the cascade controller described in *Alternate Programming* at the end of this chapter.

Although pump applications are highlighted in this chapter, the procedures and setting are nearly identical for fan applications, such as controlling multiple cooling tower fans. Differences between fan and pump settings are described in the procedures.

General information on how to program the adjustable frequency drive through the local control panel keypad are presented in Chapter 4, *User Interface*.

■ Initial Setup

Instructions for programming Quick Menu items 1-20 are presented in Chapter 5, *VLT Drive and Cascade Controller Card Setup*. Parameters 1-20 must be programmed into the Master drive before programming additional Master/Slave cascade control options described below.

Cascade Controller Option

■ Step 1: Master drive programming

The following drive parameters are used in programming the Master drive. Note that while the menu items are in sequence, not each menu item in the Quick Menu is programmed.

Quick Menu 021 Par. 712 Motor Pump Combinations (PUMP COMBINATION)

Value:

R6 @100% ★ R6 @100%
 R6, R7 @100%
 R6-R8 @100%
 R6-R9 @100%

Function:

The number of slave pumps or fans is selected in this parameter. In Master/Slave operation, all motors are the same size.

R6 @100% = one slave controlled by relay 6.

R6, R7 @100% = two slaves controlled by relays 6 and 7.

R6-R8 @100% = three slaves controlled by relays 6, 7, and 8.

R6-R9 @100% = four slaves controlled by relays 6, 7, 8, and 9.

Description of choice:

Select the number of slave pumps or fans.

Quick Menu 023 Par. 714 SBW staging off time (DESTAGING DELAY)

Value:

0 - 3000 sec. ★ 30 sec.

Function:

Destaging delay time is used to prevent the fast cycling off of the slave pumps or fans. Increase the time if frequent switching is encountered.

Description of choice:

Set staging off delay time. In Master/Slave operation, 3 seconds is a typical value.

Quick Menu 024 Par. 715 SBW staging on time (STAGING DELAY)

Value:

0 - 3000 sec. ★ 30 sec.

Function:

Staging delay time is used to prevent the fast cycling on of the slave pumps or fans. Increase the time if frequent switching is encountered.

Description of choice:

Set staging on delay time. In Master/Slave operation, 3 seconds is a typical value.

Quick Menu 029 Par. 418 Setpoint 1 (SETPOINT 1)

Value:

Feedback Min. to Feedback Max. ★ 0.000

Function:

The default feedback process is used when a pressure feedback signal is measured at the outlet of the pumps. The cascade controller uses the feedback to estimate the setpoint required at various rates of flow. Setpoint 1 is the minimum pressure required when the system is running with only the adjustable frequency drive operating at full speed. Setpoint 1 is a theoretical value that the cascade controller uses as an internal reference to calculate pressure loss in the system under minimum load. The controller adjusts the internal reference based upon the number of pumps in operation.

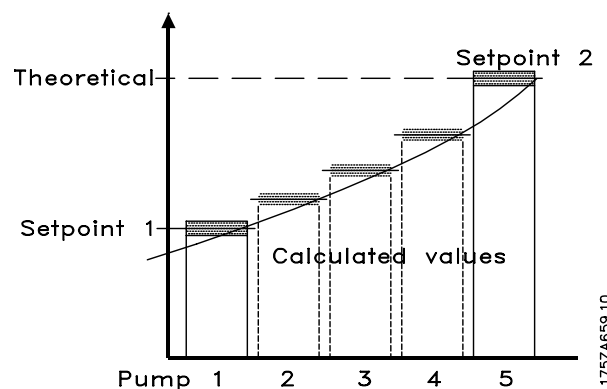

The range is determined by Quick Menu item 14 (parameter 413, *Minimum Feedback*) and Quick Menu item 15 (parameter 414, *Maximum Feedback*). When the pressure feedback signal originates at the far end of the system, the drive does not need to compensate for system pressure changes due to flow. For this system configuration, or for two setpoint PID control, see *Alternative Programming* at the end of this chapter.

Cascade Controller Option

Description of choice:

Set the desired feedback minimum within the programmed minimum and maximum in Quick Menu items 14 and 15. The process unit is selected in Quick menu item 13, *Process Units*.



NB!:

Factory setting is for a single 4 - 20 mA current signal transmitter for process feedback. In all other cases, see instructions in Chapter 10, *Feedback Transmitter Wiring*.

Quick Menu 030 Par. 419 Setpoint 2

(SETPOINT 2)

Value:

Feedback Min. to Feedback Max. ★ 0.000

Function:

The default feedback process is used when a pressure feedback signal is measured at the outlet of the pumps. The cascade controller uses the feedback to estimate the setpoint required at various rates of flow. Setpoint 2 is the maximum pressure required when the system is running with all pumps at full capacity. A theoretical value calculates pressure loss in the system under maximum load. The controller adjusts the loading based upon the number of pumps in operation.

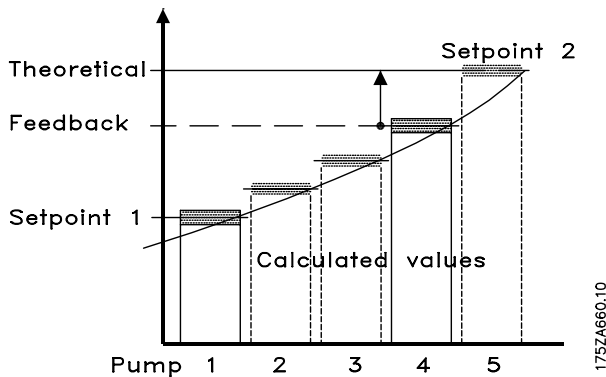

The range is determined by Quick Menu item 14 (parameter 413, *Minimum Feedback*) and Quick Menu item 15 (parameter 414, *Maximum Feedback*).

When the pressure feedback signal originates at the far end of the system, the drive does not need to compensate for system pressure changes due to flow. For this system configuration, or for two setpoint PID control, see *Alternative Programming* at the end of this chapter.

Description of choice:

Set the desired feedback maximum within the programmed minimum and maximum in Quick Menu

items 14 and 15. The process unit is selected in Quick menu item 13, *Process Units*.

Quick Menu 032 Par. 722 Pump cycling

(PUMP CYCLING)

Value:

Enabled - Disabled ★ Enabled

Function:

To achieve equal hours of operation, use of pumps or fans can be cycled. Timers on the relay outputs (relays 6, 7, 8, and 9) monitor the running hours of each pump. In staging on, the relay with the least hours is switched on. In destaging, the relay with the most hours is switched off. Not operating a pump over long time periods can create corrosion concerns.

If cycling is disabled, the controller follows the fixed pattern of relay activation (6, 7, 8 and 9) regardless of the running hours. Destaging is in the reverse order.

Description of choice:

Choose whether to enable or disable the function.

Quick Menu 033 Par. 319 Analog output, terminal 42

(AO 42 FUNCTION)

Value:

Output, terminal 42 ★ Output current 4-20 mA

Function:

An analog/digital output is available through terminal 42 and can be programmed to show a status or an analog value such as frequency. For the analog output, there are three types of output signals: 0 to 20 mA, 4 to 20 mA, or 0 to 32000 pulses. The pulse rate is set by parameter 320, *Terminal 42, Output, Pulse Scaling*.

Description of choice:

Set the output of terminal 42 to *Output Frequency (pulse sequence)*, (OUT.FREQ.PULSE) for Master/Slave operation as shown in the wiring diagram in Chapter 4. Using frequency pulse is a reliable way of providing the same speed reference to all slave drives. Current output is limited to two slave drives.

System pressure and flow requirements can often be generated using parallel pumps at different efficiencies. The cascade controller can automatically configure the number of pumps in operation to achieve the highest system efficiency. Running three pumps at full

Cascade Controller Option

speed, for example, may satisfy system requirements, while running four pumps at a lower speed meets requirements and achieves higher efficiency.

Danfoss has available the Multiple Unit Staging Efficiency Calculator (MUSEC), a free software program available on the Danfoss website. By entering pump and system data, MUSEC provides the programmer with on and off staging frequencies for each pump at optimal efficiency. Enter the data for each pump in Extended Menu parameters 739 and 740. For a free download, go to www.danfoss.com and enter MUSEC in the search box.

Quick Menu 034 Par. 739 Master/Slave staging on frequencies

(M/S STAGE FREQ)

Value:

Min. freq - Max. freq
(Par. 201 - 202) ★ Min. freq.

Function:

Best efficiency staging on frequency can be calculated for the cascade controller based on pump and system curves to meet feedback requirements. Use the MUSEC software program to determine the most efficient staging on frequency for each pump.

Description of choice:

Enter the staging on frequency for each pump. After pressing the CHANGE DATA key in parameter 739, use the (+) and (-) keys to scroll through all four slave settings.

If the pump or system data is unknown, refer to the section *Alternative Programming* at the end of this chapter.

Quick Menu 035 Par. 740 Master/Slave staging off frequencies

(M/S DESTAGE FREQ)

Value:

Min. freq - Max. freq
(Par. 201 - 202) ★ Min. freq.

Function:

Best efficiency staging off frequency can be calculated for the cascade controller based on pump and system curves to meet feedback requirements. Use the MUSEC software program to determine the most efficient staging off frequency for each pump.

Description of choice:

Enter the staging off frequency for each pump. After pressing the CHANGE DATA key in parameter 740, use the (+) and (-) keys to scroll through all four slave settings.

If the pump or system data is unknown, refer to the section *Alternative Programming* at the end of this chapter.

Quick Menu 040 Par. 420 PID normal/inverse control (PID NOR/INV. CTRL)

Value:

★ Normal (NORMAL) [0]
Inverse (INVERSE) [1]

Function:

This determines how the drive's PID controller responds to a difference between the setpoint and feedback. *Normal* is when the drive is to reduce the output frequency as the feedback signal increases. *Inverse* is when the drive is to increase the output frequency as the feedback signal increases.

Description of choice:

Select the PID controller response option.

■ Step 2: Slave drive programming

The slave drives run in open loop mode and receive stop/start and speed reference commands from the Master drive. Each slave drive must be programmed with the nameplate data from the motor it controls. All other applicable parameter settings must match the settings in the Master drive.

All parameter settings can be transferred from one VLT drive to another by using the removeable keypad. Parameter 004, *LCP Copy*, allows this function. First, upload all parameter values to the Local Control Panel (LCP) keypad. The keypad can then be removed and plugged into another VLT drive where all parameter values can be downloaded. If motor or drive sizes differ, *Download Power-independent Parameters* can be selected in parameter 004 to omit downloading motor and current dependent data.

Manual programming of slave drives is also possible following the procedure described for Master drive programming. To copy required Master drive parameter settings manually into each slave drive,

enter Master drive settings for Quick Menu items 7-13 and 18-19 into each slave drive.

Commissioning slave drives is done in the following sequence of events:

Enter Motor Nameplate Data

Enter the nameplate data from each motor into its associated drive in accordance with Quick Menu items 001 - 006 in Chapter 6, *VLT Drive and Cascade Control Card Setup*.

Download master drive programming data

Use the Master LCP to download parameter settings into the slave drives in accordance with procedures in Extended Menu parameter 004, LCP Copy. The Extended Menu is accessed by pressing the [EXTEND. MENU] key on the LCP keypad.

Extended Menu Par. 004 LCP Copy	
(LCP COPY)	
Value:	
★No copying (NO COPY)	[0]
Upload all parameters (UPLOAD ALL PARAMET.)	[1]
Download all parameters (DOWNLOAD ALL PARAM.)	[2]
Download power-independent parameters (DOWNLOAD SIZE INDEP.)	[3]

Function:

This parameter is used to copy all parameter setups to or from the Local Control Panel (LCP) keypad. It can be used to store a backup copy of all parameters in the LCP or to copy all setups from one drive to another.

Description of choice:

Select *Upload all parameters* to copy all parameter values from the drive to the LCP.
 Select *Download all parameters* to copy all parameter values from the LCP to the drive on which the keypad is mounted.
 Select *Download power-independent parameters* if only the power-independent parameters are to be downloaded. This allows the parameters from one drive to be easily copied to another drive of a different size. Settings in parameters 102, 103, 104, 105, 106, 215, 221, and 222 are not downloaded using this function.



NB!:

Copying is only possible when drive is stopped.

■ Alternate programming:

Pump/system data for MUSEC unavailable:

In cases where the pump or system data points are not known, the best efficiency staging and destaging frequencies are difficult to calculate. Operation of the system is possible with an approximation of the best efficiency function.

1. Set staging on frequency in Quick Menu item 34 (parameter 739, *Master/Slave staging on frequency*), to the maximum frequency set in Quick Menu item 08 (parameter 202, *Output frequency high limit*).
2. For an approximation of best efficiency, set the destaging frequencies in Quick Menu item 35 (parameter 740, *Master/Slave staging off frequency*), to half of the frequency set between Quick Menu item 08 (parameter 202) and Quick Menu item 07 (parameter 201, *Output frequency low limit*).

Alternate Feedback Programming:

In water supply systems, it is often impractical to place a pressure sensor at the far end of the system. In HVAC and other applications, however, it is often possible to place the pressure sensor(s) at the farthest significant load and measure actual pressure in the system. In these cases, the cascade option can use the drive's PID controller to respond to system changes as programmed. Pumps or fans are staged on and off in response to the system feedback signal.

The most common setup for feedback response is with a single transmitter located at the farthest significant load in the system. Programming the cascade controller option in this manner is described below. It is also possible for the PID to accept two feedback signals, making two-zone regulation available. For two feedback control, and for additional setting options, see the *VLT Operating Instructions*.

Setup for feedback response is with a single transmitter located at the farthest significant load in the system requires programming parameter 417, *Feedback Function*, and parameter 418, *Setpoint 1*. Parameter 417, *Feedback Function*, is only accessible through the Extended Menu. The Extended Menu is accessed by pressing the [EXTEND. MENU] key on the drive control panel. Parameter 418 may be accessed through either the Extended Menu or as item 29 in the Quick Menu.

Extended Menu Par. 417 Feedback Function

(2 FEEDBACK, CALC.)

Value:

- Minimum (MINIMUM)
- Maximum (MAXIMUM)
- Sum (SUM)
- Difference (DIFFERENCE)
- Average (AVERAGE)
- Two-zone minimum (2 ZONE MIN)
- Two-zone maximum (2 ZONE MAX)

- ★Virtual Control Curve (VIRTUAL CTRL CURVE)
 - Feedback 1 Only (FEEDBACK 1 ONLY)
 - Feedback 2 Only (FEEDBACK 2 ONLY)

Function:

This parameter sets the calculation method whenever a system feedback signal is used, or when two feedback signals (Setpoint 1 and Setpoint 2) are used.

Description of choice:

Select the feedback calculation method required. Maximum uses Setpoint 1 as the maximum reference signal for control. See the *VLT Operating Manual* for additional information.

Quick Menu 029 Par. 418 Setpoint 1

(SETPOINT 1)

Value:

Feedback Min. to Feedback Max. ★ 0.000

Function:

Setpoint 1 is used to provide the setpoint reference for one setpoint PID control or for the setpoint for zone 1 in two setpoint PID control.

Description of choice:

Set the required value the system is to maintain during normal operation. The value must be between the minimum and maximum values set in Quick Menu items 14 and 15 (parameter 413, *Minimum Feedback*, and parameter 414, *Maximum Feedback*). Setpoint 2, Quick Menu item 30, is not used in one feedback signal applications.

■ System Optimisation

■ System start up and final adjustments

After Master drive and slave programming is complete, and after all system safety procedures have been ensured and the system is operational, final adjustments can be made to reach maximum efficiency for drive and cascade controller operation.

Final adjustments involves the following:

- a. Setting the best efficiency frequency in the cascade controller for staging and destaging pumps and fans
- b. Optimization of the process regulator

■ Best efficiency frequency

Quick Menu 041 Par. 422 PID start-up frequency (PID START VALUE)

Value:
 $f_{MIN-fMAX}$ (parameters 201 and 202) ★ 0 Hz

Function:
 Each time the drive is given a start command, the start up frequency is the speed the drive accelerates to before PID control is activated. The drive will follow the acceleration ramp when a start signal is received as if in open loop. When the programmed start frequency is reached, it will change to closed loop operation.

Description of choice:
 Set the required start frequency. A setting near the operating speed will enable the system to stabilize more quickly. For pump applications, set this high enough to ensure flow from the pump.

Quick Menu 042 Par. 427 PID lowpass filter time (PID FILTER TIME)

Value:
 0.01 - 10.00 ★ 1.00

Function:
 Noise on the feedback signal can be reduced with the lowpass filter.

Description of choice:
 Select the desired time constant (t). The cut off frequency equals $1/2\pi t$. For example, if a time constant of 0.1 s is programmed, the cut off frequency for the lowpass filter will be $1/[2\pi (.1)] = 1.6$ Hz.

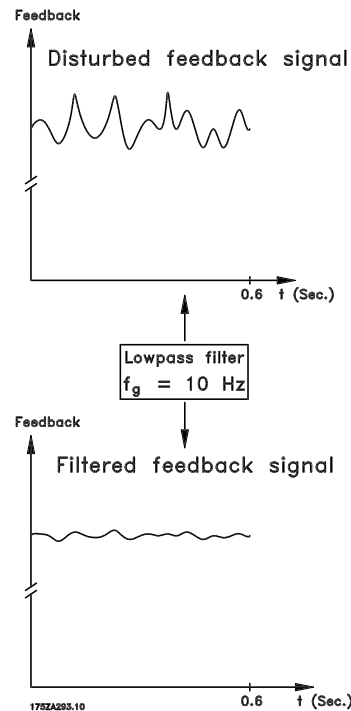

The PID controller will then only respond to changes in the feedback signal whose frequency is less than 1.6 Hz.

■ Optimization of the process regulator

Quick Menu 043 Par. 423 PID proportional gain

(PID PROP. GAIN)

Value:

0.00 - 10.00 ★ 0.01

Function:

Determines how fast the system responds to a change in feedback.

Description of choice:

Quick regulation is obtained by a high gain, but if the gain is too high, the process may become unstable. See *Optimization of the Process Regulator* for information on proper adjustment.

Quick Menu 044 Par. 424 PID integration time

(PID INTEGR. TIME)

Value:

0.01 - 9999.00 sec. (OFF) ★ OFF

Function:

The integrator adds the error signal over time and uses this to correct the speed of the drive. The integration time is the time needed by the integrator to have the same effect as the proportional gain.

Description of choice:

Fast regulation is obtained by setting a short integration time. However, if this time is too short, the process will overcorrect and become unstable. See *Optimization of the Process Regulator* for information on proper adjustment.

Procedure for Optimization of the Process Regulator

The process regulator is set by Quick Menu items 43 and 44 (parameters 423 and 424). To optimize the proportional gain and integration time, in most processes, this can be done as follows:

1. Start the motor.
2. Set parameter 423, *PID Proportional Gain*, to 0.3 and increase it until the feedback signal becomes unstable. Then reduce the value until the feedback signal has stabilized. Now lower the proportional gain by about half (40% to 60%).
3. Set parameter 424, *PID Integration Time*, to 20 seconds and reduce the value until the feedback signal becomes unstable. Increase the integration time until the feedback signal stabilizes. Now increase the integration time from 15% to 50%.

Starting and stopping the drive will produce the necessary error signal in the process to set the PID.

PID equation:

The VLT PID controller operates in accordance to the following equation:

$$\text{PID out} = P[e(t) + 1/ I \int e(t) dt] + D e(t)/dt$$

Feedback Transmitter Wiring

Connecting feedback transmitters

Terminal 12 and 13 of the VLT provide access to a 24 VDC, 200 mA power supply. This can be used to power remote transmitters, so an external power supply is generally not needed. The diagrams below show how to wire two- and three-wire transmitters.

Single 4 - 20 mA feedback transmitter connection:

175ZA665.10

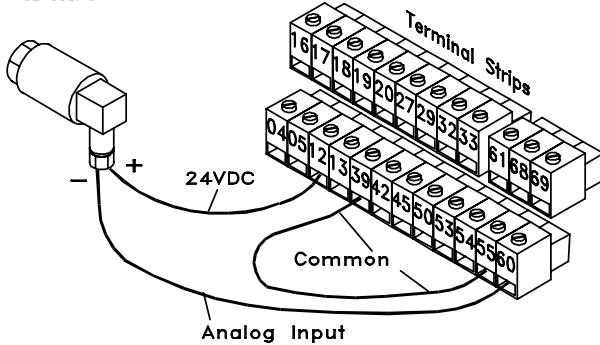

Programming:

Parameter Number	Parameter Description	Parameter Value
415	REF./FDBK UNIT	Process unit
413	MIN. FEEDBACK	Transmitter low limit
414	MAX. FEEDBACK	Transmitter high limit
308	AI [V] 53 FUNCT.	NO OPERATION
311	AI [V] 54 FUNCT.	NO OPERATION
314	AI [mA] 60 FUNCT	FEEDBACK
315	AI 60 SCALE LOW	4 mA
316	AI 60 SCALE HIGH	20 mA

Single 0 - 10 V feedback transmitter connection:

175ZA666.10

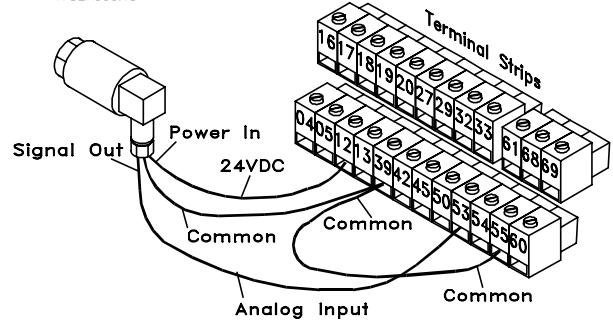

Programming:

Parameter Number	Parameter Description	Parameter Value
415	REF./FDBK UNIT	Process unit
413	MIN. FEEDBACK	Transmitter low limit
414	MAX. FEEDBACK	Transmitter high limit
308	AI [V] 53 FUNCT.	FEEDBACK
309	AI 53 SCALE LOW	0 V
310	AI 53 SCALE HIGH	10 V
314	AI [mA] 60 FUNCT	NO FUNCTION

Two 0 - 10 V feedback transmitter connections:

When two feedback signals are used with the VLT, both signals must be voltage signals. Both transmitters must also have the same range.

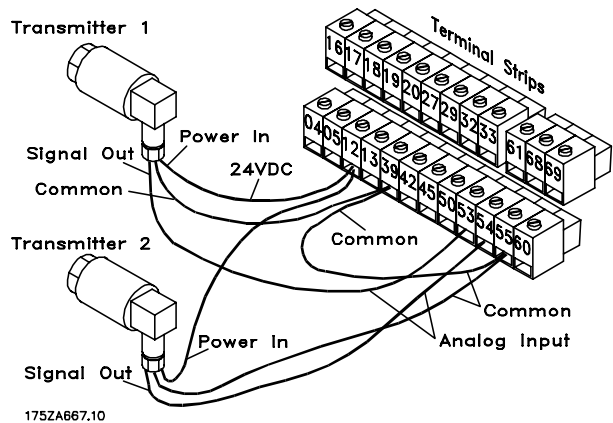

175ZA667.10

Cascade Controller Option

Programming:

Parameter Number	Parameter Description	Parameter Value
415	Ref./FDBK UNIT	Process unit
413	MIN. FEEDBACK	Transmitter low limit
414	MAX. FEEDBACK	Transmitter high limit
417	2 FEEDBACK CALC.	Desired operation
308	AI [V] 53 FUNCT.	FEEDBACK
309	AI 53 SCALE LOW	0V
310	AI 53 SCALE HIGH	10V
311	AI [V] 54 FUNCT.	FEEDBACK
312	AI 54 SCALE LOW	0V
313	AI 54 SCALE HIGH	10V
314	AI [mA] 60 FUNCT.	NO OPERATION

Two 4 - 20 mA feedback transmitters connection:

When two feedback signals are used, the VLT requires that they both be connected to its analog voltage inputs, terminals 53 and 54. Transmitters that produce a current signal can be used by adding two resistors.

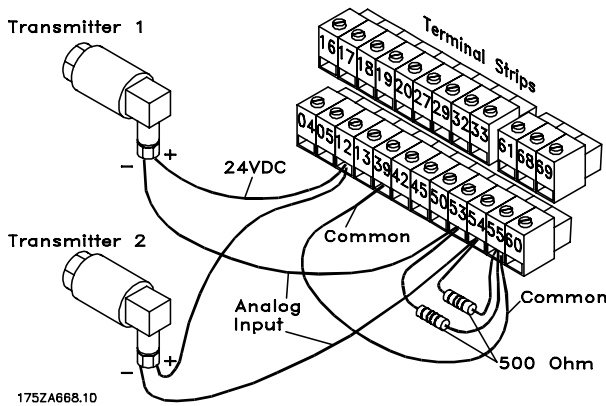

If the transmitter is capable of producing 10V at 20 mA, the value of the resistor to use is:

$$R = \frac{10V}{20mA} = 500\Omega$$

The input scaling of the VLT analog inputs in this case would have to be 2 - 10 Volt.

Programming:

Parameter Number	Parameter Description	Parameter Value
415	Ref./FDBK UNIT	Process unit
413	MIN. FEEDBACK	Transmitter low limit
414	MAX. FEEDBACK	Transmitter high limit
417	FEEDBACK CALC.	Desired operation
308	AI [V] 53 FUNCT.	FEEDBACK
309	AI 53 SCALE LOW	2V
310	AI 53 SCALE HIGH	10V
311	AI [V] 54 FUNCT.	FEEDBACK
312	AI 54 SCALE LOW	2V
313	AI 54 SCALE HIGH	10V
314	AI [mA] 60 FUNCT.	NO OPERATION

Two feedback signals and two setpoints:

Similar to two feedback signals and one setpoint, the need for two feedback signals with two setpoints is frequently encountered. Whenever two critical zones do not have the same setpoint value, two feedback with two setpoint control is required. Many pumping systems require the monitoring and control of two loads that differ in size and pressure drop. Or this can be effective when controlling different temperature zones in cooling or heating applications.

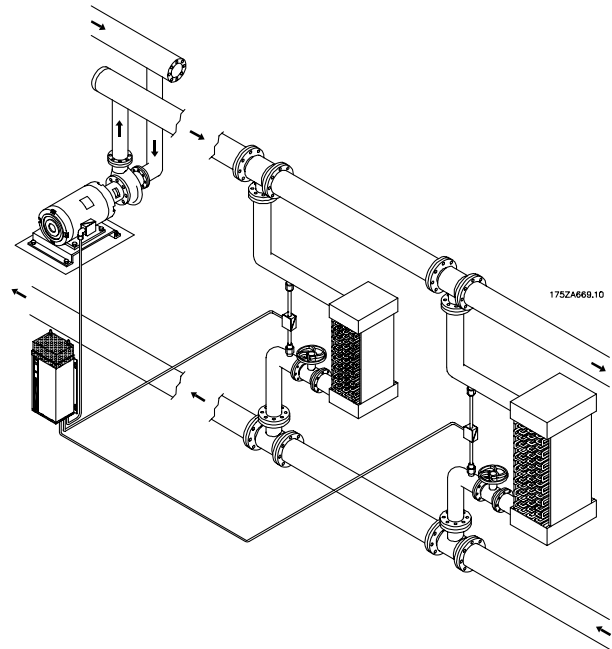

To enable this setup, the feedback function in parameter 417, *Feedback Function*, is selected. When selecting *2-zone Minimum* in parameter 417, the drive will regulate the system so the feedbacks are equal to or greater than their associated setpoints. If *2-zone Maximum* is selected, the feedbacks will be equal to or less than their associated setpoints.

Feedback 1 is associated with Setpoint 1 and Feedback 2 is associated with Setpoint 2. The two independent groupings are continuously monitored to satisfy both zones requirements.

Transmitter connection to the VLT:

The transmitters are connected to the VLT in the same way as shown above with 1 setpoint and 2 feedbacks. The feedback connected to terminal 53 is assigned to setpoint 1 and the one connected to terminal 54 to setpoint 2. Both transmitters must have the same output signal and range.

Programming example for 2 feedback and 2 setpoint controls:

Transmitter ratings:

Supply: 15 - 30 VDC

Output: 0 - 10 V

Range: 0 - 100 Pa

The VLT is programmed to match its input to follow the specification of the transmitter:

Programming:

Parameter	Parameter	Parameter
Number	Description	Value
100	CONFIG. MODE	CLOSED LOOP
415	Ref./FDBK UNIT	Pa
413	MIN. FEEDBACK	0
414	MAX. FEEDBACK	100
308	AI [V] 53 FUNCT.	FEEDBACK
309	AI 53 SCALE LOW	0
310	AI 53 SCALE HIGH	100
311	AI [54] 54 FUNCT.	FEEDBACK
312	AI 54 SCALE LOW	0
313	AI 54 SCALE HIGH	100
314	AI [mA] 60 FUNCT.	NO OPERATION

The reference range is generally set to equal the range of the transmitter. In this way, the setpoint (reference) can be set to any value that the transmitter can produce. If required, the reference range can be set to a range that is narrower than the transmitter's range, but it cannot be set to a wider range.

Parameter	Parameter	Parameter
Number	Description	Value
204	MIN. REFERENCE	0
205	MAX. REFERENCE	100

In this example, load 1 requires a pressure of at least 30 Pa and load 2 at least 60 Pa.

Parameter	Parameter	Parameter
Number	Description	Value
417	2 FEEDBACK CALC.	2 ZONE MIN
418	SETPOINT 1	30
419	SETPOINT 2	60

Cascade Controller Option

■ Parameter group 700 definitions

Para	Name	Description	Unit	Range	Factory Setting	Change During Operation	Data Type	Conversion Index
712	PUMP COMBINATION	Selects number and size of slave pumps	No.	1 - 8	R6@100	No	5	0
713	STAGING BANDW. %	Pump Staging Bandwidth in % of setpoint	%	1.0 - 100.0	5.0%	Yes	6	-1
714	DESTAGING DELAY	Pump Staging Bandwidth off	Sec.	0.0 - 3000.0	10 sec.	Yes	6	-1
715	STAGING DELAY	Pump Staging Bandwidth on	Sec.	0.0 - 3000.0	10 sec.	Yes	6	-1
716	OVERRIDE BANDW.%	Over-ride Bandwidth	%	2.0 - 100.0	100%	Yes	6	-1
717	OVERRIDE TIMER	Over-ride Bandwidth hysteresis time	Sec.	0.0 - 300	10 sec.	Yes	6	-1
718	STAGING FREQ%	Frequency at staging in % of max speed	%	0.0 - 100.0	90%	Yes	6	-1
721	DESTAGE TIME	Destage timer	Sec.	Par. 403 - 600	OFF	Yes	6	0
722	PUMP CYCLING	Enable or disable pump cycling		Enabled/Disabled	Enable	No	5	0
723	OPERATIONAL MODE SELECT	Selects either Standard or Master/Slave control		Standard/Master Slave	Standard	No	5	0
724	PUMP 2 ON TIME	Hour meter for pump 2	Hrs	0 - 130000	0.0	Yes	7	-1
725	PUMP 3 ON TIME	Hour meter for pump 3	Hrs	0 - 130000	0.0	Yes	7	-1
726	PUMP 4 ON TIME	Hour meter for pump 4	Hrs	0 - 130000	0.0	Yes	7	-1
727	PUMP 5 ON TIME	Hour meter for pump 5	Hrs	0 - 130000	0.0	Yes	7	-1
728	PUMP 2 CYCLES	Cycle counter for pump 2	No.	0 - 130000	0.0	Yes	7	0
729	PUMP 3 CYCLES	Cycle counter for pump 3	No.	0 - 130000	0.0	Yes	7	0
730	PUMP 4 CYCLES	Cycle counter for pump 4	No.	0 - 130000	0.0	Yes	7	0
731	PUMP 5 CYCLES	Cycle counter for pump 5	No.	0 - 130000	0.0	Yes	7	0
736	RELAY ON TIME	Relay hour meter, relay R6 - R9	Hrs	0 - 130000	0.0	No	7	-1
737	RELAY CYCLES	Relay Cycle counter, rela	No.	0 - 130000	0.0	No	7	-1
738	SETPOINTS HM 1- 7	Calculated intermediate setpoint, relay (Hm1-Hm7)	Para 415	H0 - H1	0.000	No	4	-3
739	M/S STAGE FREQ	M/S Stage on frequency, relay (1-4)	Hz	Par. 201-202	Par. 202	Yes	6	-1
740	M/S DESTAGE FREQ	M/S Stage off frequency, relay (1-4)	Hz	Par. 201-202	Par. 201	Yes	6	-1
741	DESTAGING FREQ %	Frequency at destaging in % of max. speed	%	0.0-100.0	10	Yes	6	-1
750	ALTERNATION TIME	Lead pump alternation	Hrs.	0-999,9	0	Yes	6	-1
751	ELAPSED ALT. TIME	Time to alternate	Hrs.	0-par. 750	0	Yes	6	-1
752	ALTERNATION REGISTER	Lead pump alternation		1- 4	1	Yes	5	0
753	ALTERNATION RESTART DELAY	Lead pump alternation	sec.	0-60	5	Yes	5	0

Parameter group 700, all parameters

Conversion Index Factors

Conversion Index	Conversion Factor
74	3.6
2	100.0
1	10.0
0	1.0
-1	0.1
-2	0.01
-3	0.001
-4	0.0001

DataType Descriptions

Data type	Description
3	Integer 16
4	Integer 32
5	Unsigned 8
6	Unsigned 16
7	Unsigned 32
9	Text string

■ Service parameters

■ Display information

Parameters 724 through 738 provide operational information including the number of hours run, cycles, and the state of the relay for each pump.

Par. 724 - 727 Pump-on time
(PUMP x ON TIME)

Parameter number	Pump number
724	Pump 2
725	Pump 3
726	Pump 4
727	Pump 5

Value:
h 0 - 130000

Function:
The relay timer accumulates the hours (h) the pump has run (the relay switched on). The counter is updated 10 times per hour which means that cycles less than 6 minutes are not registered. The hours can be reset to zero when a pump is replaced since the cascade controller uses parameter 736, *Relay On Time*, to determine cycling patterns.

Par. 728 - 731 Pump cycles
(PUMP x CYCLES)

Parameter number	Pump number
728	Pump 2
729	Pump 3
730	Pump 4
731	Pump 5

Value:
No. 0 - 130000

Function:
The cascade controller counts the number (No.) of times each relay (pump) is switched on. The cycle counter can be reset to zero when a pump is replaced.

Par. 736 Relay-on time

(RELAY ON TIME)

Value:
h 0 - 130000

Function:

The relay timer accumulates the hours (h) each relay has been switched on and is used by the cascade controller to determine the cycling pattern. This counter cannot be reset. A new pump will not compensate for older pumps. The new pump will cycle in regular rotation.

Par. 737 Relay cycles

(RELAY CYCLES)

Value:
No. 0 - 130000

Function:

The relay timer accumulates the number (No.) of times each relay has been switched on and is used by the cascade controller to determine the cycling pattern. This counter cannot be reset.

Par. 738 Calculated intermediate setpoint

(SETPOINTS HM 1 - 7)

Value:
(set by Par. 415) sp 1 - sp 2

Function:

The intermediate setpoint is used internally by the cascade controller to calculate the system setpoint. This parameter displays the setpoint for information. Setpoint data is entered in parameters 418, *Setpoint 1*, and 419, *Setpoint 2*.

■ Relay status

The display panel on the VLT allows reading the status of the relays.

Press the [DISPLAY MODE] key. Use the [+] and [-] keys to scroll through the list to RELAY STATUS. The relay status readout consists of 8 binary digits. The first digit (starting from left) indicates the status of Relay 01 which is located in the power section of the VLT. The second digit is Relay 02 which is located on the VLT control card. Digits 3 - 6 indicate the four relays of the cascade controller, relays 06, 07, 08 and 09 which are located on the option board. Digits 7-8 are reserved for future use.

The readout can be very useful during commissioning to see how many fixed speed or slave pumps are in operation.

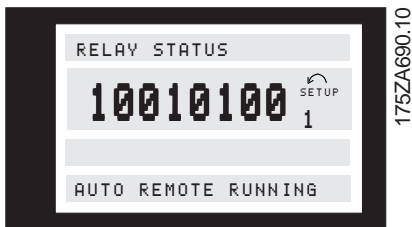

Value:

Relay open	[0]
Relay closed	[1]



NB!:

For readout via serial communication, parameter 537 must be used.

Bit 7 = Relay 01,
Bit 6 = Relay 02,
Bits 5-2 = Relays 06 - 09.