

■ Contents

Safety	3
How to use this manual	3
Safety regulations	4
Warning against unintended start	4
Installation of mechanical brake	4
Introduction	5
Abbreviations and Definitions	5
Technology	8
Technical data	13
Mechanical dimensions	13
Installation	16
Safety earthing	19
Electrical installation - mains supply	19
Motor connection	19
Electrical installation - brake cable	20
Electrical installation - brake resistor temperature switch	20
Electrical installation - loadsharing	20
Electrical installation - 24 Volt external DC supply	22
Electrical installation - relay outputs	22
Extra protection (RCD)	23
Terminal Designation	30
Connection examples	34
Electrical installation - EMC precautions	36
Use of emc-correct cables	39
Electrical installation - earthing of control cables	40
RFI switch	41
Control Panel (LCP)	44
Control panel (LCP)	44
Display	44
LEDs	44
Control keys	44
Quick Setup via Quick menu	47
Menu mode (Parameter setting)	47
Initialisation to factory setting	48
Reference Handling	50
Local and remote control	50
Handling of single references	51
Handling of multi-references	53
Programming of stop at torque limit	54
Dynamic brake function(Brake resistor)	55
Automatic Motor Adaptation, AMA	57
Flying start	59
Normal/high overload torque control	59

Programming	60
Operation and Display	60
Load and motor	67
Functional Stop Delay, par 163 - Flux	77
References and limits	79
.....	89
Special Functions	103
Mains failure, par 407 - Flux	106
Serial communication	110
Technical functions	116
Miscellaneous	121
Trouble-shooting	121
Status messages	122
List of warnings and alarms	125
Warnings	126
Appendix	133
Parameter survey	133
General technical data	140
Electrical data	146
Fuses	156
Index	158

■ **How to use this manual**

This manual provides you with the information necessary to install, start-up and operate the frequency converter. We recommend you to read this manual carefully.



When using a cross reference in text please see contents.

You may also visit Danfoss Drives' homepage: www.danfoss.com/drives

■ **Software version**

VLT 5000 FLUX

Operating Instructions
Software version: 5.5x

These Operating Instructions can be used for VLT 5000 FLUX frequency converters with software version 5.5x. The software version number can be seen from parameter 624.

175ZA735.15

Safety



Warning:

Touching the electrical parts may be fatal - even after the equipment has been disconnected from mains.

Also make sure that other voltage inputs have been disconnected, such as external 24 V DC, load-sharing (linkage of DC intermediate circuit), as well as the motor connection for kinetic back-up.

Using VLT 5001-5006, 200-240 V:	wait at least 4 minutes
Using VLT 5008-5052, 200-240 V:	wait at least 15 minutes
Using VLT 5001-5006, 380-500 V:	wait at least 4 minutes
Using VLT 5008-5062, 380-500 V:	wait at least 15 minutes
Using VLT 5072-5302, 380-500 V:	wait at least 20 minutes
Using VLT 5352-5502, 380-500 V:	wait at least 40 minutes

175ZA901.11



The voltage of the frequency converter is dangerous whenever the equipment is connected to mains. Incorrect installation of the motor or the frequency converter may cause damage to the equipment, serious personal injury or death. Consequently, the instructions in this manual, as well as national and local rules and safety regulations, must be complied with.

■ Safety regulations

1. The frequency converter must be disconnected from mains if repair work is to be carried out. Check that the mains supply has been disconnected and that the necessary time has passed before removing motor and mains plugs.
2. The [STOP/RESET] key on the control panel of the frequency converter does not disconnect the equipment from mains and is thus not to be used as a safety switch.
3. Correct protective earthing of the equipment must be established, the user must be protected against supply voltage, and the motor must be protected against overload in accordance with applicable national and local regulations.
4. The earth leakage currents are higher than 3.5 mA.
5. Protection against motor overload is not included in the factory setting. If this function is desired, set parameter 128 to data value *ETR trip* or data value *ETR warning*.
Note: The function is initialised at 1.16 x rated motor current and rated motor frequency. For the North American market: The ETR functions provide class 20 motor overload protection in accordance with NEC.
6. Do not remove the plugs for the motor and main supply while the frequency converter is connected to mains. Check that the mains supply has been disconnected and that the necessary time has expired before removing motor and mains plugs.
7. Please note that the frequency converter has more voltage inputs than L1, L2 and L3, when loadsharing (linking of DC intermediate circuit) and external 24 V DC have been installed. Check that all voltage inputs have been disconnected and that the necessary time has passed before repair work is commenced.

■ Warning against unintended start

1. The motor can be brought to a stop by means of digital commands, bus commands, references or a local stop, while the frequency converter is connected to mains. If personal safety considerations make it necessary to ensure that no unintended start occurs, these stop functions are not sufficient.
2. While parameters are being changed, the motor may start. Consequently, the stop key [STOP/RESET] must always be activated, following which data can be modified.
3. A motor that has been stopped may start if faults occur in the electronics of the frequency converter, or if a temporary overload or a fault in the supply mains or the motor connection ceases.

■ Installation of mechanical brake

Do not connect a mechanical brake to the output from the frequency converter before the relevant parameters for brake control are parameterised.

(Selection of output in parameter 319, 321, 323 or 326 and cut-in current and frequency in parameter 223 and 225).

■ Use on isolated mains

See section *RFI Switch* regarding use on isolated mains.

It is important to follow the recommendations regarding installation on IT-mains, since sufficient protection of the complete installation must be observed. Not taking care using relevant monitoring devices for IT-mains may result in damage.

■ Abbreviations and Definitions
■ Frequency converter

Abbreviation/Definition	Description
$I_{VLT,MAX}$	The maximum output current of the frequency converter.
$I_{VLT,N}$	The rated output current of the frequency converter.
$U_{VLT,MAX}$	The maximum output voltage.

■ Output

Abbreviation/Definition	Description
Break-away torque	<p style="text-align: center;">175ZA521.11</p>
f_M	The frequency transmitted to the motor
I_M	The current transmitted to the motor
n_{min}	Minimum speed [rpm]
n_{max}	Maximum speed [rpm]
n_{JOG}	Speed by jog operation [rpm]
U_M	The voltage transmitted to the motor
η_{VLT}	The efficiency of the frequency converter is defined as the ratio between the power output and power input

Introduction

■ Switch NO/NC

Abbreviation/Definition	Description
NO	Normally open
NC	Normally closed

■ Input

Abbreviation/Definition	Description
Control command Immediate stop Stop command	By means of LCP and the digital inputs, it is possible to start and stop the connected motor.

■ Motor

Abbreviation/Definition	Description
$f_{M,N}$	The rated motor frequency (nameplate data)
$I_{M,N}$	The rated motor current (nameplate data)
I_0	Idle current
$n_{M,N}$	The rated motor speed (nameplate data)
n_{slip}	Slip in motor speed
$P_{M,N}$	The rated power delivered by the motor (nameplate data)
P_0	Power losses at idle state
R_{Fe}	Iron loss resistance
R_2'	Rotor resistance
R_S	Stator resistance
$T_{M,N}$	The rated torque (motor)
$U_{M,N}$	The rated motor voltage (nameplate data)
$X_{1\sigma}$	Stator Leakage Reactance
$X'_{2\sigma}$	Rotor Leakage Reactance
X_h	Main Reactance

■ References

Abbreviation/Definition	Description
Analogue ref.	A signal transmitted to input 53, 54 or 60. Can be voltage or current
Binary ref.	A signal transmitted to the serial communication port
Ref _{MAX}	The maximum value which the reference signal may have. Set in parameter 205

■ Miscellaneous

Abbreviation/Definition	Description
Analogue inputs	The analogue inputs can be used for controlling various functions of the frequency converter. There are two types of analogue inputs: Current input and voltage input
Analogue outputs	There are two analogue current outputs
AWG	Means American Wire Gauge, ie. the American measuring unit for cable cross-section
Brake resistor	The brake resistor is a module capable of absorbing the brake power that is generated in regenerative braking. This regenerative braking power increases the intermediate circuit voltage and a brake chopper ensures that the power is transmitted to the brake resistor
ccw	Counter Clockwise rotation
CL	Closed Loop
Coast (motor)	The motor is free running to stop
CP	Constant power
CT characteristics	Constant torque characteristics, used for all applications, such as conveyor belts and cranes.
cw	Clockwise rotation
DC Link	Intermediate circuit in the frequency converter
Digital inputs	The digital inputs can be used for controlling various functions of the frequency converter
Digital outputs	There are four digital outputs, two of which activate relay switches.
DSP	Digital Signal Processing. The FLUX processor is defined as a DSP

■ Miscellaneous- continued

Abbreviations/Definitions	Description
ED	Duty cycle
ELCB	Earth Leakage Circuit Breaker
ETR	Electronic thermal relay is a thermal load calculation based on present load and time. Its purpose is to estimate the motor temperature
Flux Vector	If compared with standard voltage/frequency ratio control, Flux Vector improves the dynamics and the stability, both when the speed reference is changed and in relation to the load torque
Incremental encoder	An external, digital pulse transmitter used for feeding back information on motor speed. The encoder is used in applications where high accuracy in speed control is required
Initializing	If initializing is carried out (see parameter 620), the frequency converter returns to the factory setting
KTY	Semiconductor temperature sensor
LCP	The Local Control Panel, which makes up a complete interface for control and programming of the frequency converter. The control panel is detachable and may, as an alternative, be installed up to 3 metres away from the frequency converter, ie. in a front panel, by means of the installation kit option
Manual initialisation	Press the [CHANGE DATA] + [MENU] + [OK] keys at the same time as power-up to carry out manual initialisation. See also Parameter 620. Note that manual initialisation is only to be used if the reset function does not work!
MCM	Stands for Mille Circular Mil, an American measuring unit for cable cross-section 1 MCM=0.5067mm ²
NEC	National Electrical Code
NTC	Negative Temperature Coefficient resistor
On-line/off-line parameters	On-line parameters are activated immediately after the data value is changed. Off-line parameters are not activated until OK has been entered on the control unit
OP	Open Loop
OVC	Over Voltage Control
PELV	Protective Electrical Low Voltage. According to EN 50178
ppr	Puls per revolutions
RPM	Revolutions per minute
Thermistor	A temperature-dependent resistor placed where the temperature is to be monitored (VLT or motor)
Trip	A state which occurs in different situations, eg. if the frequency converter is subject to a live zero warning. A trip can be cancelled by pressing Reset
Trip locked	A state which occurs in different situations, eg. if the frequency converter is subject to an overtemperature. A locked trip can be cancelled by cutting off mains and restarting the frequency converter and pressing Reset

■ **Technology**

The motor is thus supplied with variable voltage and frequency, which enables infinitely variable speed control of three-phased, standard AC motors.

■ **Control Principle**

A frequency converter rectifies AC voltage from mains into DC voltage. This DC voltage is then converted into a AC voltage with a variable amplitude and frequency.

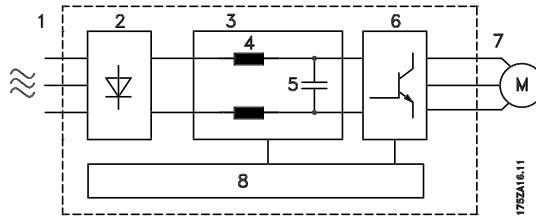

1. Mains voltage

3 x 400 - 500 V AC, 50 / 60 Hz.

2. Rectifier

A three-phase rectifier bridge that rectifies AC voltage into DC voltage.

3. Intermediate circuit

$$\text{DC voltage} = \sqrt{2} \times \text{mains voltage}$$

4. Intermediate circuit coils

Smooth the intermediate circuit current and limit the load on mains and components (mains transformer, wires, fuses and contactors).

5. Intermediate circuit capacitors

Smooth the intermediate circuit voltage.

6. Inverter

Converts DC voltage into variable AC voltage with a variable frequency.

7. Motor voltage

Variable AC voltage, 0-100% of mains supply voltage.
Variable frequency: 0 - 300 Hz.

8. Control circuit

On basis of parameters, reference settings and input signals, pulse patterns are generated for forming the variable motor voltage and frequency.

■ **Flux Vector Control Principle**

The aim of developing the Flux Vector control principle has been to obtain a robust motor control that is tolerant to different motor characteristics without motor derating being required.

The current is split into magnetising and torque-generating parts and provides for much better and quicker estimation of the actual motor loads. It is now possible to compensate for rapid load changes. Full torque as well as extremely accurate speed control can now be obtained even at low speeds or even at standstill.

Good torque control properties and smooth transitions to and from current limit operation are ensured.

Advantages of the Flux Vector control system:

- Accurate speed control down to 0 speed
- Quick response from received signal to full motor shaft torque
- Good compensation for step loads

- Controlled transition from normal operation to current limit operation (and vice versa)
- Torque control, comprising control of both the torque-generating and the magnetising component of the current
- Full holding torque

Programmable signal outputs

The frequency converter uses a digital technique which makes it possible to program the signal outputs.

For the user, it is easy to program the desired functions by means of the control panel on the frequency converter or the RS 485/RS 232 user interfaces.

Protection against mains interference

The frequency converter is protected against the transients that occur in the mains supply, eg. when switching power factor correction or when fuses blow.

The rated motor voltage and full torque can be maintained all the way down to 10% undervoltage in the mains supply.

Minor interference on mains

Since as standard the frequency converter features intermediate circuit coils, there is only a small amount of harmonic mains supply interference. This ensures a good power factor and lower peak current, which reduces the load on the mains installation.

Advanced VLT protection

Current measurement on all three motor phases provides perfect protection of the frequency converter against earthing and short-circuiting faults on the motor connection.

Efficient monitoring of the three mains supply phases ensures that the unit stops in the case of phase failure. This avoids overloading the inverter and the capacitors in the intermediate circuit, which would dramatically reduce the service life of the frequency converter.

As standard, the frequency converter features integral thermal protection. If a situation of thermal overload occurs, this function cuts out the inverter.

Reliable galvanic isolation

In the frequency converter all of the control circuits are separated from mains potential through isolation meeting the PELV requirements.

One set of relay contacts, terminals 01 - 03, is separated from the remaining control circuits through isolation also complying with PELV.

Furthermore, the control circuits are placed in blocks individually separated through functional isolation (< 100 V), see section *General Technical Data*.

Advanced motor protection

The frequency converter features integrated electronic, thermal motor protection.

The frequency converter calculates the motor temperature on the basis of current, frequency and time.

As opposed to the traditional bimetallic protection, electronic protection takes account of the reduction in cooling at low frequencies that comes from reduced fan speed (motors with internal ventilation).

To obtain maximum protection against overheating of the motor if the motor is covered or blocked, or if the fan fails, a thermistor can be integrated and connected to the thermistor input of the frequency converter (terminals 53 or 54), see parameters 128, 308 and 311.

■ Key Diagram for VLT 5001–5027

200-240 V, VLT 5001–5102 380-500 V

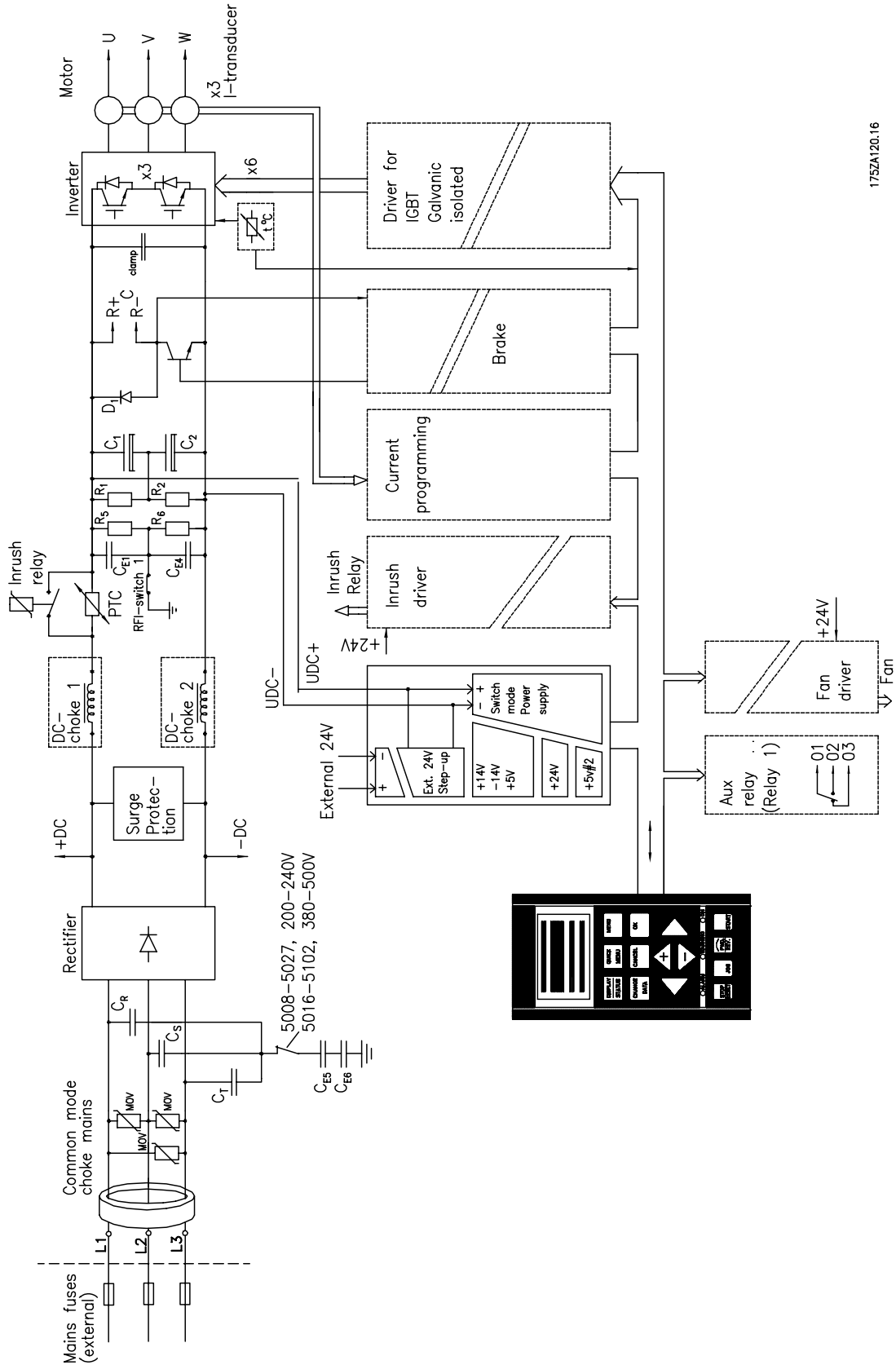

175ZA120.16

■ Key Diagram for VLT 5122-5502 380-500 V

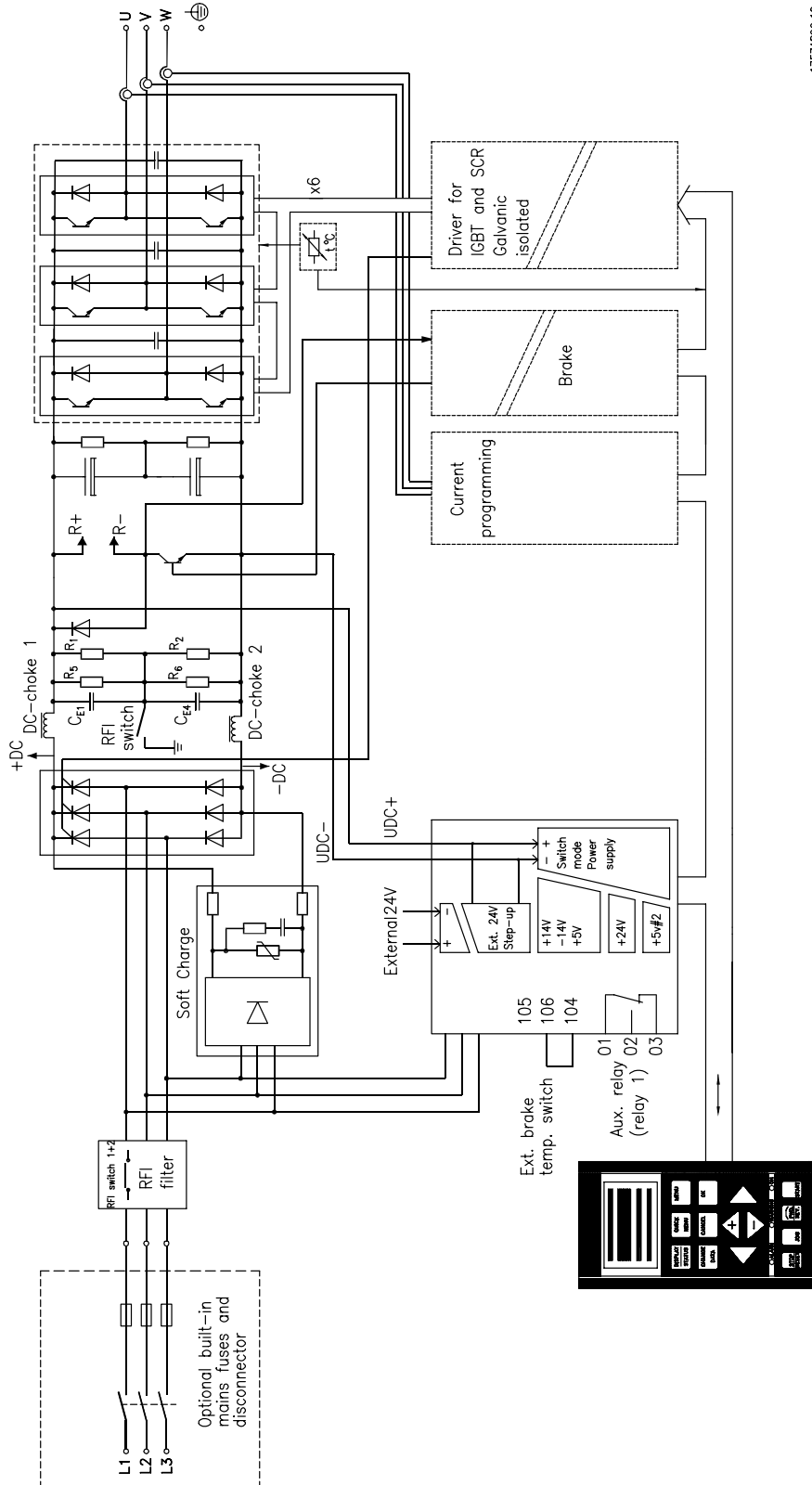

17524699-10

Introduction

■ Key Diagram for VLT 5032–5052 200–240 V

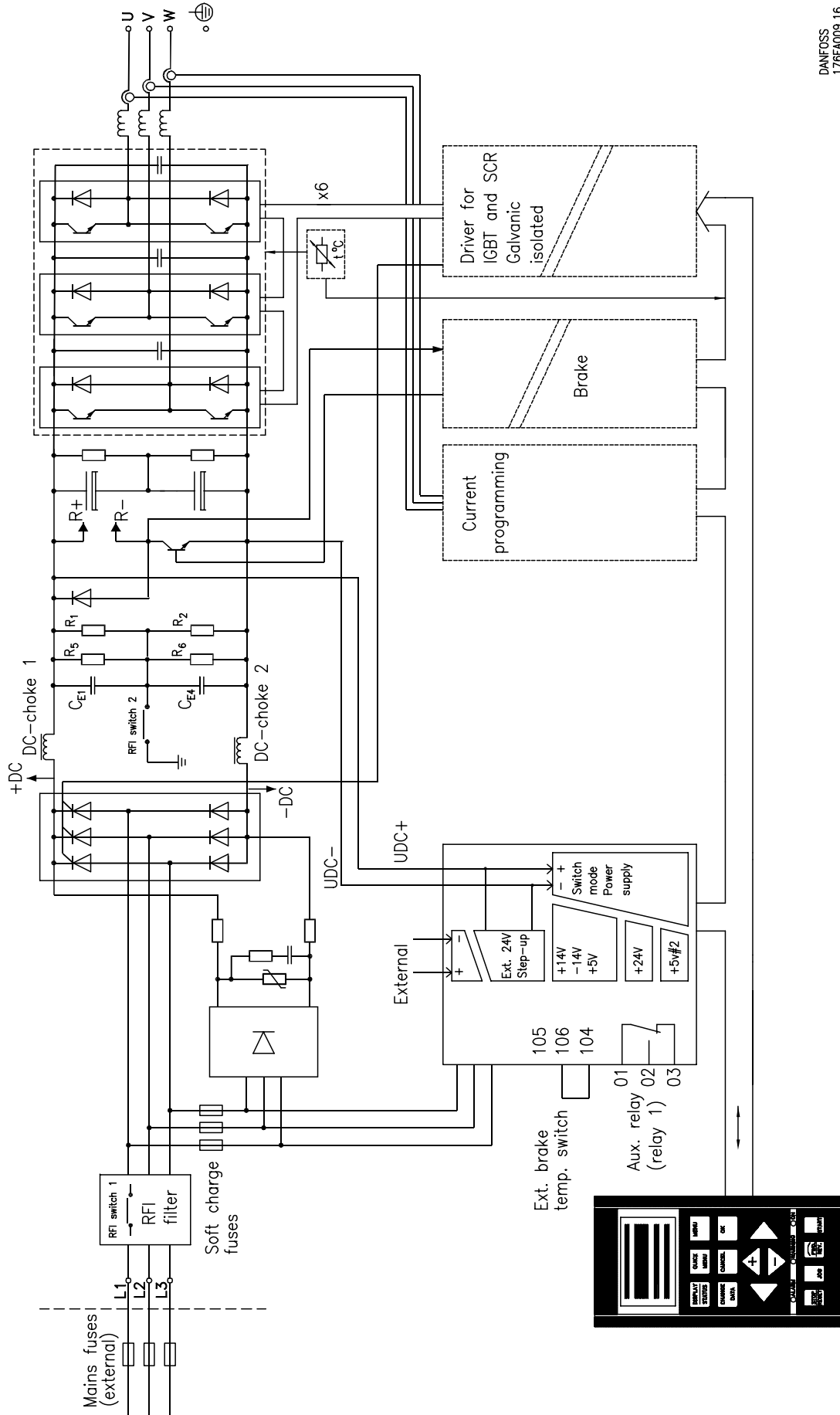

DANFOSS
176FA09.16

■ Mechanical dimensions

All the below listed measurements are in mm.

	A	B	C	D	a	b	ab/be	Type
Bookstyle IP 20								
5001 - 5003 200 - 240 V								
5001 - 5005 380 - 500 V	395	90	260		384	70	100	A
5004 - 5006 200 - 240 V								
5006 - 5011 380 - 500 V	395	130	260		384	70	100	A
Compact IP 00								
5032 - 5052 200 - 240 V	800	370	335		780	270	225	B
5122 - 5152 380 - 500 V	1046	408	375 ²⁾		1001	304	225	J
5202 - 5302 380 - 500 V	1327	408	375 ²⁾		1282	304	225	J
5352 - 5502 380 - 500 V	1896	1099	494		1847	1065	400 ¹⁾	I
Compact IP 20								
5001 - 5003 200 - 240 V								
5001 - 5005 380 - 500 V	395	220	160		384	200	100	C
5004 - 5006 200 - 240 V								
5006 - 5011 380 - 500 V	395	220	200		384	200	100	C
5008 200 - 240 V								
5016 - 5022 380 - 500 V	560	242	260		540	200	200	D
5011 - 5016 200 - 240 V								
5027 - 5032 380 - 500 V	700	242	260		680	200	200	D
5022 - 5027 200 - 240 V								
5042 - 5062 380 - 500 V	800	308	296		780	270	200	D
5072 - 5102 380 - 500 V	800	370	335		780	330	225	D
Compact Nema 1/IP20/IP21								
5032 - 5052 200 - 240 V	954	370	335		780	270	225	E
5122 - 5152 380 - 500 V	1208	420	373 ²⁾		1154	304	225	J
5202 - 5302 380 - 500 V	1588	420	373 ²⁾		1535	304	225	J
5352 - 5502 380 - 500 V	2010	1200	600		-	-	400 ¹⁾	H
Compact IP 54/Nema 12								
5001 - 5003 200 - 240 V								
5001 - 5005 380 - 500 V	460	282	195	85	260	258	100	F
5004 - 5006 200 - 240 V								
5006 - 5011 380 - 500 V	530	282	195	85	330	258	100	F
5008 - 5011 200 - 240 V								
5016 - 5027 380 - 500 V	810	350	280	70	560	326	200	F
5016 - 5027 200 - 240 V								
5032 - 5062 380 - 500 V	940	400	280	70	690	375	200	F
5032 - 5052 200 - 240 V	937	495	421	-	830	374	225	G
5072 - 5102 380 - 500 V	940	400	360	70	690	375	225	F
5122 - 5152 380 - 500 V	1208	420	373 ²⁾	-	1154	304	225	J
5202 - 5302 380 - 500 V	1588	420	373 ²⁾	-	1535	304	225	J
5352 - 5502 380 - 500 V	2010	1200	600	-	-	-	400 ¹⁾	H

ab: Minimum space above enclosure'

be: Minimum space below enclosure

1: Only above enclosure (ab) IP 00 when built in a Rittal cabinet.

2: With disconnect, add 42 mm.

Technical data

■ Mechanical dimensions, cont.

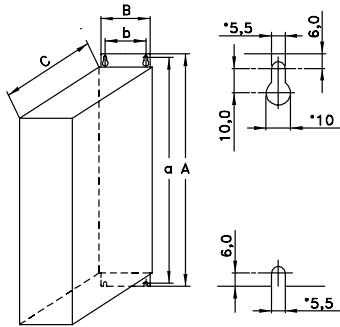

Type A, IP20

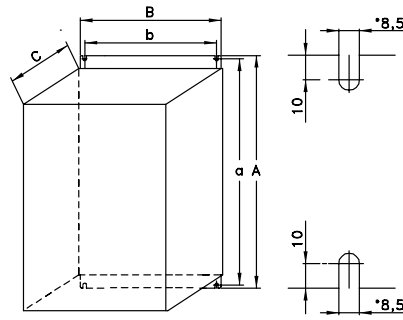

Type D, IP20

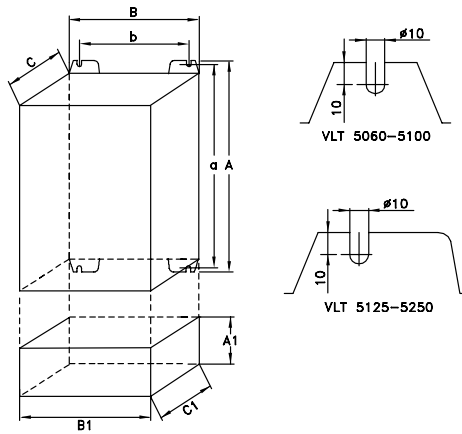

Type B, IP00
With option and enclosure IP20

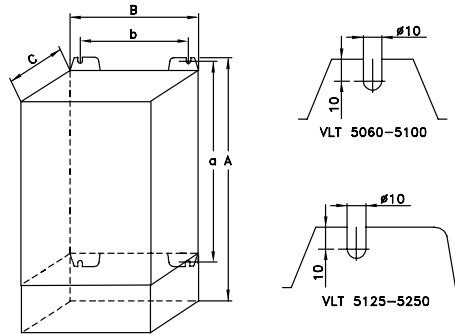

Type E, IP20/NEMA 1 with terminals

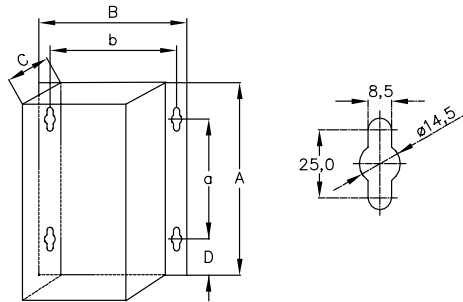

Type F, IP54

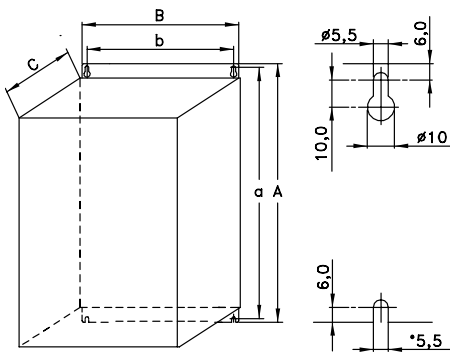

Type C, IP20

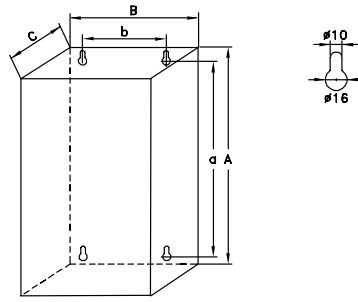

Type G, IP54

175ZA577.12

■ Mechanical dimensions (cont.)

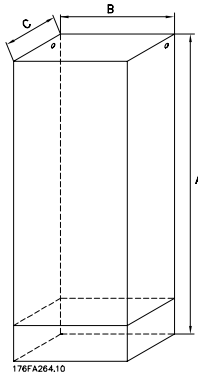

Type H, IP 20, IP 54

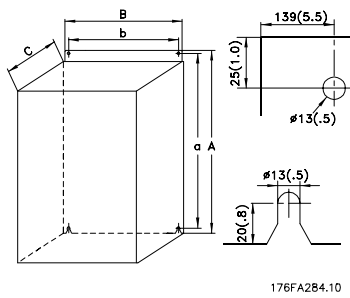

Type I, IP 00

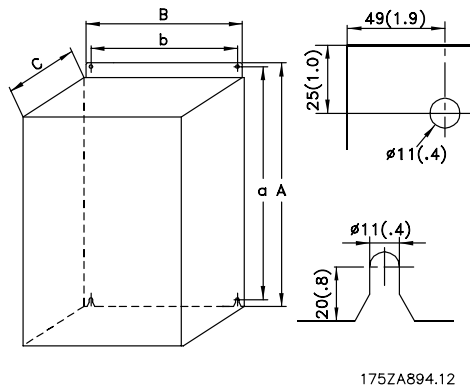

Type J, IP 00, IP 21, IP 54

Technical data



Please pay attention to the requirements that apply to integration and field mounting kit, see the below list. The information given in the list must be observed to avoid serious damage or injury, especially when installing large units.

The frequency converter *must* be installed vertically.

The frequency converter is cooled by means of air circulation. For the unit to be able to release its cooling air, the *minimum* distance over and below the unit must be as shown in the illustration below.

To protect the unit from overheating, it must be ensured that the ambient temperature *does not rise above the max. temperature stated for the frequency converter and that the 24-hour average temperature is not exceeded*. The max. temperature and 24-hour average can be seen from the General Technical section.

Derating of the frequency converter is required by ambient temperature in the range of 45° C - 55° C. See the section *Derating* in the Design Guide. Service Life Time of the frequency converter will be reduced if no derating is carried out in the above ambient temperature range.

All frequency converters can be mounted side by side/flange by flange.

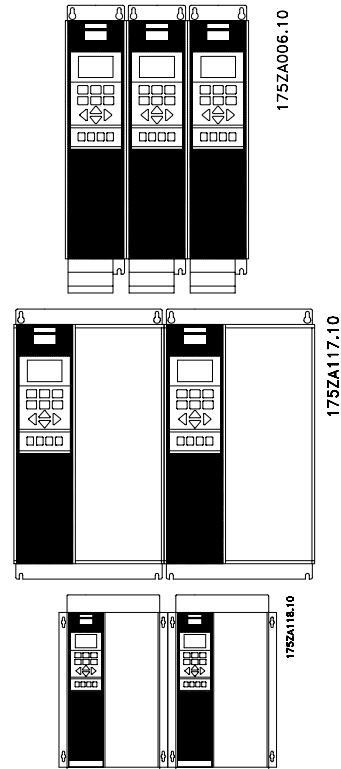

■ Enclosure type

	IP 00	IP 20/Nema 1	IP 54
Bookstyle	-	OK	-
Compact	OK	OK	OK

■ Installation of VLT 5001-5502

All frequency converters must be installed in a way that ensures proper cooling.

Cooling

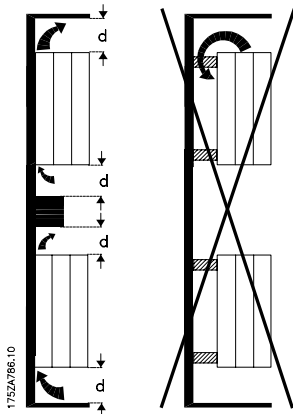

All Bookstyle and Compact units require a minimum space above and below the enclosure.

Side by side/flange by flange

	d [mm]	Comments
Bookstyle		
VLT 5001-5006, 200-240 V	100	Installation on a plane, vertical surface (no spacers)
VLT 5001-5011, 380-500 V	100	
Compact (all enclosure types)		
VLT 5001-5006, 200-240 V	100	Installation on a plane, vertical surface (no spacers)
VLT 5001-5011, 380-500 V	100	
VLT 5008-5027, 200-240 V	200	Installation on a plane, vertical surface (no spacers)
VLT 5016-5062, 380-500 V	200	
VLT 5072-5102, 380-500 V	225	
VLT 5032-5052, 200-240 V	225	Installation on a plane, vertical surface (no spacers)
VLT 5122-5302, 380-500 V	225	IP 54 filter mats must be changed when they are dirty.
VLT 5352-5502, 380-500 V	225	IP 00 above and below enclosure IP 21/IP 54 only above enclosure

■ Installation of VLT 5352-5502 380-500 V Compact
Nema 1 (IP 21) and IP 54
Cooling

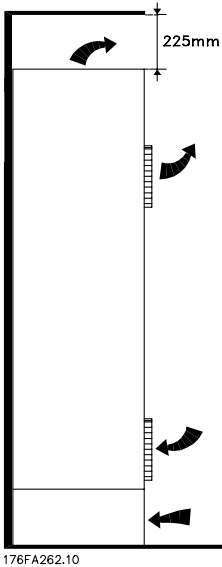

176FA262.10

All units in the above-mentioned series require a minimum space of 225 mm above the enclosure and must be installed on a flat level surface. This applies to both Nema 1 (IP 21) and IP 54 units.

Gaining access to the VLT 5352-5502 requires a minimum space of 579 mm in front of the frequency converter.

Filter mats in IP 54 units have to be changed regularly depending on the operating environment.

Side-by-side

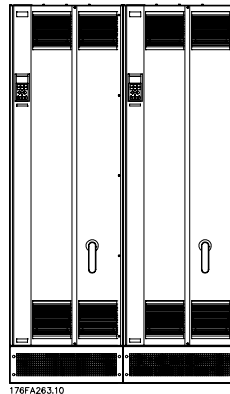

176FA263.10

Compact Nema 1 (IP 21) and IP 54

All Nema 1 (IP 21) and IP 54 units in the above-mentioned series can be installed side by side without any space between them, since these units do not require cooling on the sides.

■ Electrical installation



The voltage on the frequency converter is dangerous when the unit is connected to mains. Incorrect installation of the motor or the frequency converter may lead to material damage or serious injury or it may be fatal. Consequently, the instructions in this manual as well as national and local rules and safety regulations must be complied with. Touching the electrical parts may be fatal, even after the mains supply has been disconnected.

Using VLT 5001-5006, 200-240 V and 380-500

V: wait at least 4 minutes.

Using VLT 5008-5052, 200-240 V: wait at least 15 minutes.

Using VLT 5008-5062, 380-500 V: wait at least 15 minutes.

Using VLT 5072-5302, 380-500 V: wait at least 20 minutes.

Using VLT 5352-5502, 380-500 V: wait at least 40 minutes.



NB!:

It is the user's or certified electrician's responsibility to ensure correct earthing and protection in accordance with applicable national and local norms and standards.

■ High voltage test

A high voltage test can be carried out by short-circuiting terminals U, V, W, L₁, L₂ and L₃ and energizing by max. 2.15 kV DC for one second between this short-circuit and the chassis.



NB!:

The RFI switch must be closed (position ON) when high voltage tests are carried out (see section *RFI Switch*).

The mains and motor connection must be interrupted in the case of high voltage tests of the total installation if the leakage currents are too high.

■ Safety earthing



NB!:

The frequency converter has a high leakage current and must be earthed appropriately for safety reasons. Use earth terminal (see section *Electrical installation, power cables*), which enables reinforced earthing. Apply national safety regulations.

■ Terminal designation

The terminal designations for power connections are equal for all sizes of VLT inverters.

Mains terminals	91 R (L1)	92 S (L2)	93 T (L3)
Motor terminals	96 U	97 V	98 W
Earth terminals	94 ⊕	95 ⊕	99 ⊕
Brake resistor terminals	81 R+	82 R-	
Load sharing	88 -DC	89 +DC	

■ Electrical installation - mains supply

Connect the three mains phases to terminals L₁, L₂, L₃.

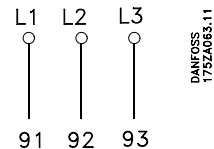

■ Motor connection

All types of 3-phased asynchronous standard motors can be used with the frequency converter.

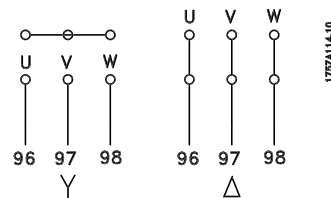

Normally, small motors are star-connected (200/400 V, Δ/Y).

Large motors are delta-connected (400/690 V, Δ/Y). Please be aware, that the motor cable must be screened.

■ Motor thermal protection

The electronic thermal relay in UL-approved frequency converters has received the UL-approval for single motor protection when parameter 128 has been set for *ETR Trip* and parameter 105 has been programmed to the rated motor current (see motor nameplate).

■ Motor shaft direction

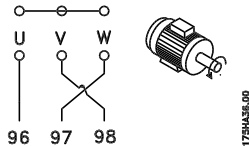
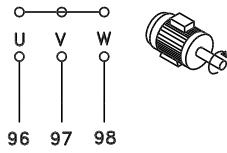

The factory setting is for clockwise rotation with the frequency converter output connected as follows:

CW	U	96	V	97	W	98
CCW	U	96	V	98	W	97

The direction of rotation can be changed by switching two phases in the motor cable.



NB!:

If the application is running in closed loop with an encoder as feedback signal, the encoder signal A,A/B,B/ wires must be swapped or the encoder direction must be changed in parameter 351.



NB!:

Flux vector drives can operate with one motor only. It is not possible to run parallel-connected motors on the output side of the frequency converter.

■ Electrical installation - brake cable

(Only standard with brake and extended with brake. Typecode: SB, EB, DE, PB).

No.	Function
81, 82	Brake resistor terminals

The connection cable to the brake resistor must be screened. Connect the screen by means of cable clamps to the conductive back plate at the frequency converter and to the metal cabinet of the brake resistor. Size the brake cable cross-section to match the brake torque. See also Brake instructions, MI.90.FX.YY and MI.50.SX.YY for further information regarding safe installation.



NB!:

Please note that voltages up to 1099 V DC, depending on the supply voltage, may occur on the terminals.

■ Electrical installation - brake resistor temperature switch

Torque: 0.5-0.6 Nm

Screw size: M3

No.	Function
106, 104, 105	Brake resistor temperature switch.



NB!:

This function is only available on VLT 5032-5052 200-240 V and VLT 5125-5502 380-500 V.

If the temperature of the brake resistor gets too high and the thermal switch drops out, the frequency converter will stop braking. The motor will start coasting.

A KLIXON switch must be installed that is 'normally closed'. If this function is not used, 106 and 104 must be short-circuited together.

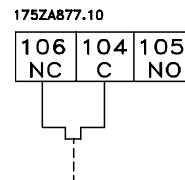

■ Electrical installation - loadsharing

(Only extended with typecode EB, EX, DE, DX).

No.	Function
88, 89	Loadsharing

Terminals for loadsharing

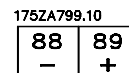

The connection cable must be screened and the max. length from the frequency converter to the DC bar is 25 metres.

Load sharing enables linking of the DC intermediate circuits of several frequency converters.



NB!:

Please note that voltages up to 1099 V DC may occur on the terminals.

Load sharing calls for extra equipment. For further information please consult Loadsharing Instructions MI.50.NX.XX.

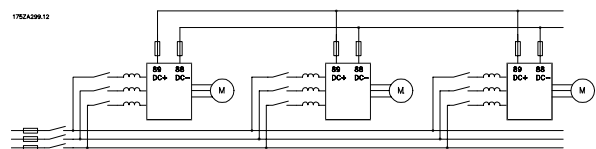

■ Tightening-up torques and screw sizes

The table shows the torque required when fitting terminals to the frequency converter. For VLT 5001-5027 200-240 V and VLT 5001-5102 380-500 V, the cables must be fastened with screws. For VLT 5032-5052 200-240 V and VLT 5122-5502 380-500 V, the cables must be fastened with bolts. These figures apply to the following terminals:

Mains terminals	Nos	91, 92, 93 L1, L2, L3
Motor terminals	Nos	96, 97, 98 U, V, W
Earth terminal	No	94, 95, 99
Brake resistor terminals		81, 82
Loadsharing		88, 89

VLT type		Torque [Nm]	Screw/ Boltsize	Tool
200-240 V				
5001-5006		0,6	M3	Slotted screw
5008	IP20	1,8	M4	Slotted screw
5008-5011	IP54	1,8	M4	Slotted screw
5011-5022	IP20	3	M5	4 mm Allen wrench
5016-5022 ³⁾	IP54	3	M5	4 mm Allen wrench
5027		6	M6	4 mm Allen wrench
5032-5052 ¹⁾		11,3	M8 (bolt and stud)	
380-500 V				
5001-5011		0,6	M3	Slotted screw
5016-5022	IP20	1,8	M4	Slotted screw
5016-5027	IP54	1,8	M4	Slotted screw
5027-5042	IP20	3	M5	4 mm Allen wrench
5032-5042 ³⁾	IP54	3	M5	4 mm Allen wrench
5052-5062		6	M6	5 mm Allen wrench
5072-5102	IP20	15	M6	6 mm Allen wrench
	IP54 ²⁾	24	M8	8 mm Allen wrench
5122-5302 ⁴⁾		19	M10 bolt	
5352-5502 ⁵⁾		42	M12 bolt	

- 1) Brake terminals: 3,0 Nm, Nut: M6
- 2) Brake and loadsharing: 14 Nm, M6 Allen screw
- 3) IP54 with RFI - Line terminals 6Nm, Screw: M6 - 5 mm Allen wrench
- 4) Loadshare and brake terminals: 9,5 Nm; Bolt M8
- 5) Brake terminals: 11,3 Nm; Bolt M8

■ Electrical installation - external fan supply

Torque 0,5-0,6 Nm

Screwsize: M3

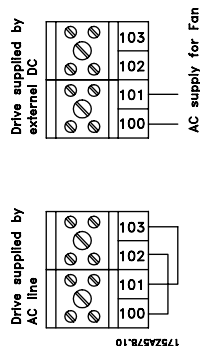

Available in 5122-5502, 380-500 V; 5032-5052, 200-240 V in all enclosure types.

Only for IP54 units in the power range VLT 5016-5102, 380-500 V and VLT 5008-5027, 200-240 V AC. If the drive is supplied by the DC bus (loadsharing), the internal fans are not supplied with AC power. In this case they must be supplied with an external AC supply.

Screw size: M3

No.	Function
1-3	Relay output, 1+3 break, 1+2 make See parameter 323 of the Operating Instructions. See also <i>General technical data</i> .
4, 5	Relay output, 4+5 make See parameter 326 of the Operating Instructions. See also <i>General technical data</i> .

■ Electrical installation - 24 Volt external DC supply

(Only extended versions. Typecode: PS, PB, PD, PF, DE, DX, EB, EX).

Torque: 0.5 - 0.6 Nm

Screw size: M3

No.	Function
35, 36	24 V external DC supply

External 24 V DC supply can be used as low-voltage supply to the control card and any option cards installed. This enables full operation of the LCP (incl. parameter setting) without connection to mains. Please note that a warning of low voltage will be given when 24 V DC has been connected; however, there will be no tripping. If 24 V external DC supply is connected or switched on at the same time as the mains supply, a time of min. 200 msec. must be set in parameter 120 *Start delay*. A pre-fuse of min. 6 Amp, slow-blow, can be fitted to protect the external 24 V DC supply. The power consumption is 15-50 W, depending on the load on the control card.



NB!

Use 24 V DC supply of type PELV to ensure correct galvanic isolation (type PELV) on the control terminals of the frequency converter.

■ Electrical installation - relay outputs

Torque: 0.5 - 0.6 Nm

■ Extra protection (RCD)

ELCB relays, multiple protective earthing or earthing can be used as extra protection, provided that local safety regulations are complied with.

In the case of an earth fault, a DC content may develop in the faulty current.

If ELCB relays are used, local regulations must be observed. Relays must be suitable for protection of 3-phase equipment with a bridge rectifier and for a brief discharge on power-up.

■ Earth leakage current

Earth leakage current is primarily caused by the capacitance between motor phases and the motor cable screen. When an RFI filter is used, this contributes additional leakage current, as the filter circuit is connected to earth through capacitors. The size of the leakage current to the ground depends on the following factors, in order of priority:

1. Length of motor cable
2. Motor cable with or without screen
3. Switching frequency
4. RFI filter used or not
5. Motor grounded on site or not

The leakage current is of importance to safety during handling/operation of the frequency converter if (by mistake) the frequency converter has not been earthed.

**NB!:**

Since the leakage current is >3.5 mA, reinforced earthing must be established, which is required if EN 50178 is to be complied with. For 3-phased frequency converters, only fault current relays which are suitable for protection against DC currents (Din VDE 0664) are to be used. RCD fault current relays type B comply with these requirements according to the norm IEC 755-2.

The following requirements must be complied with:

- Suitable for protecting equipment with a direct current content (DC) in the fault current (3-phase rectifier)
- Suitable for power-up with short pulse-shaped charging current to earth
- Suitable for a high leakage current.

■ Electrical installation, power cables

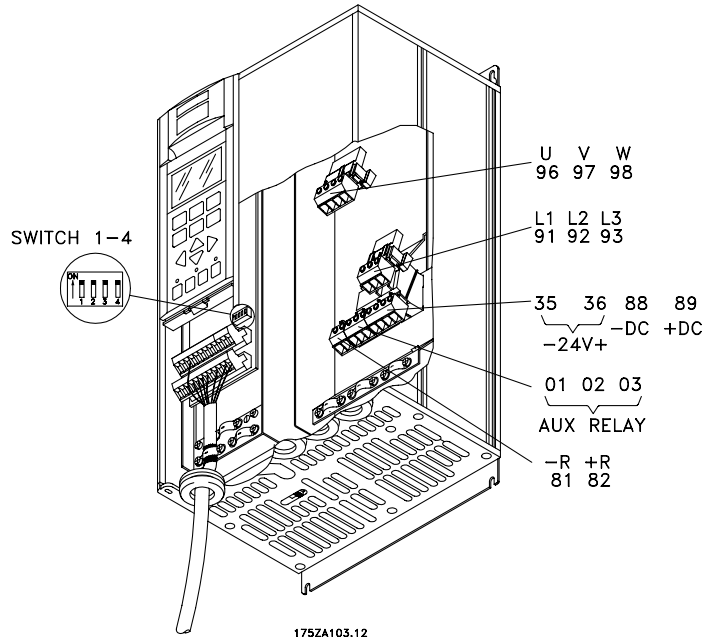
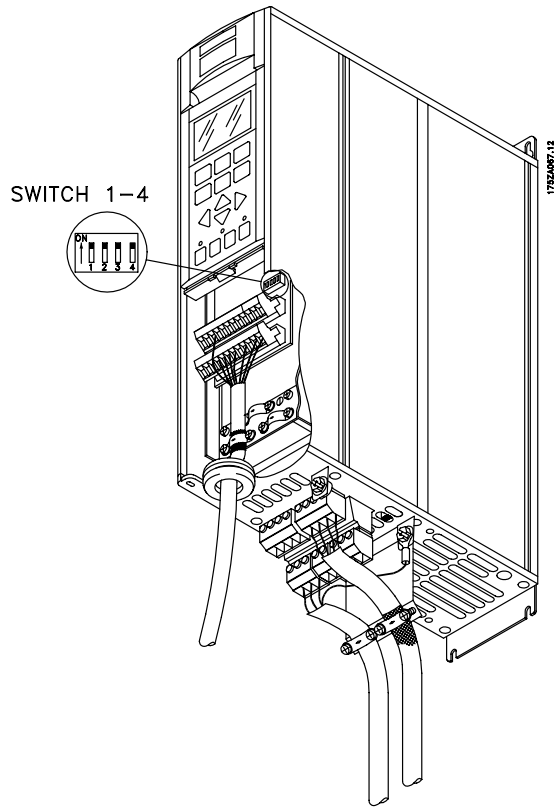

Compact IP 20/Nema 1

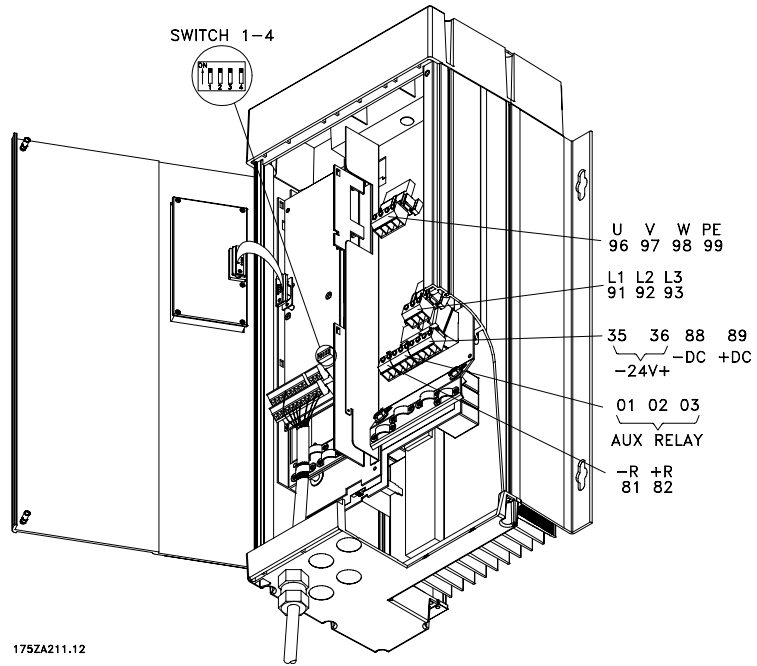
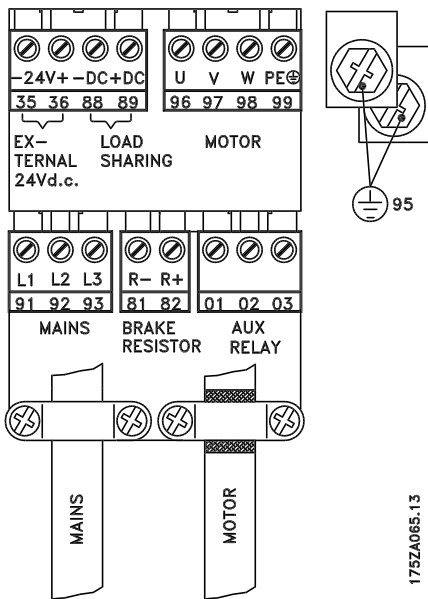

Compact IP 54

Bookstyle

VLT 5001-5006 200-240 V

VLT 5001-5011 380-500 V

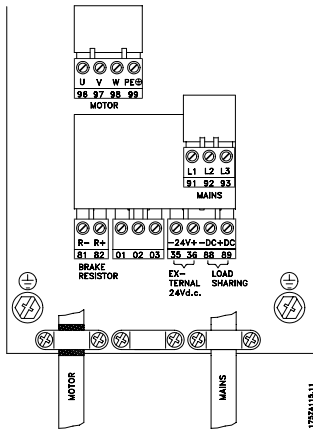

175ZA118.11

Compact

VLT 5001-5006 200-240 V

VLT 5001-5011 380-500 V

■ Electrical installation, power cables

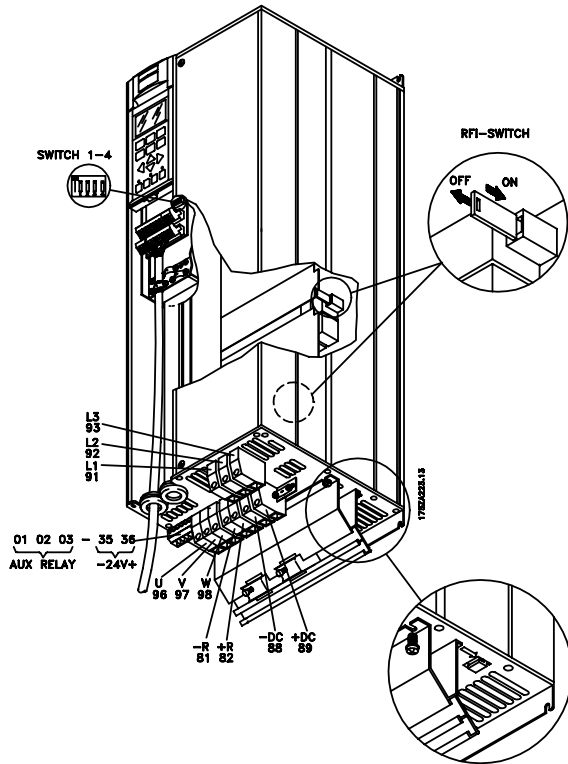

175ZA128.13

Compact IP 20/Nema 1

VLT 5008-5027 200-240 V

VLT 5016-5062 380-500 V

175ZA852.10

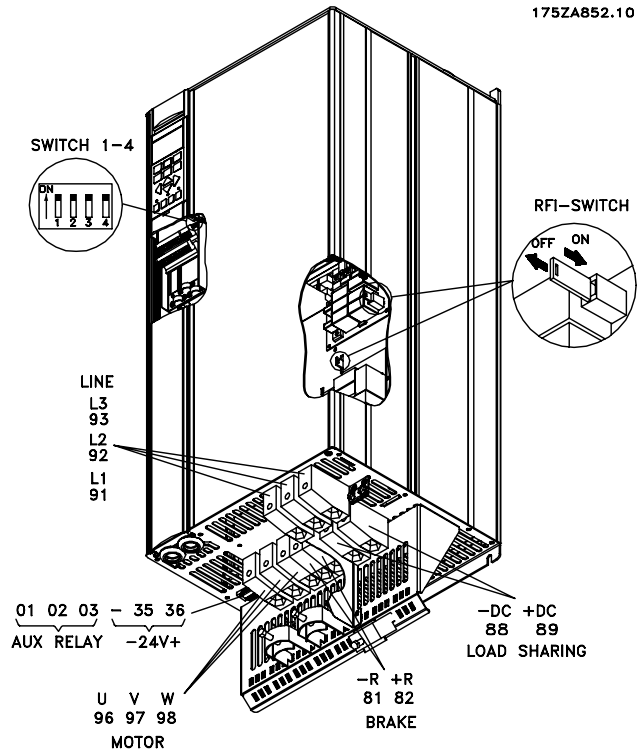

Compact IP 20

VLT 5072-5102 380-500 V

DANFOSS
175ZA121.12

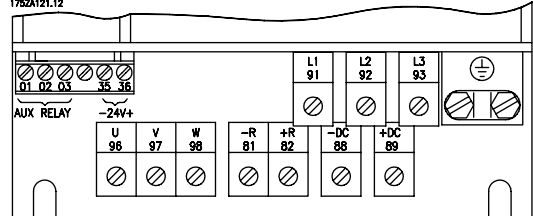

Compact IP 20/Nema 1

VLT 5008-5027 200-240 V

VLT 5016-5102 380-500 V

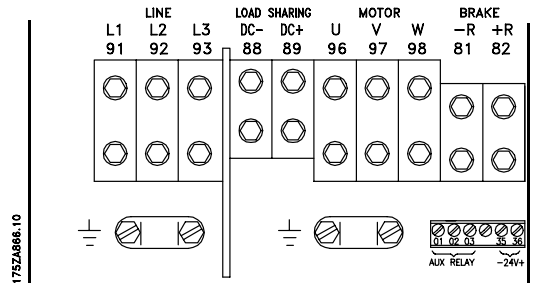
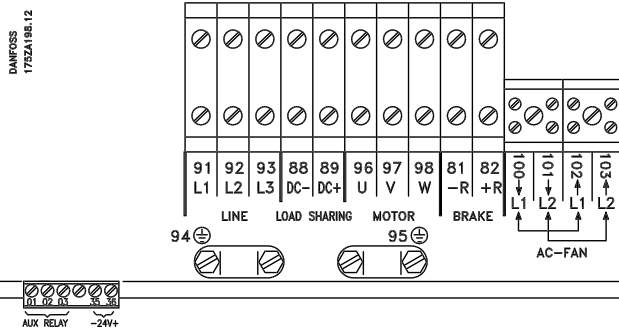
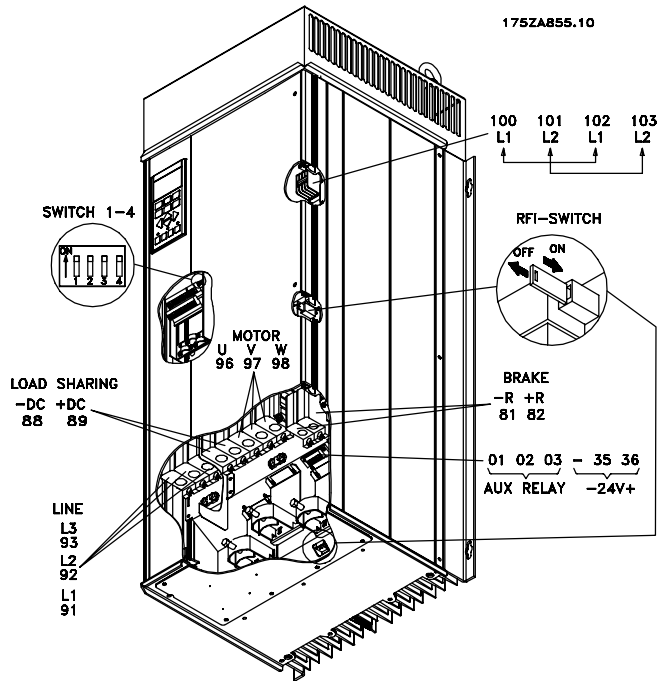
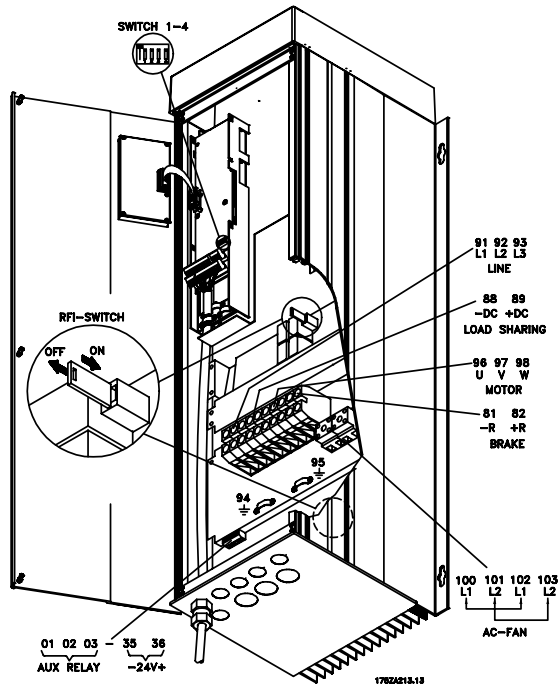

Compact IP 54

VLT 5008-5027 200-240 V

VLT 5016-5062 380-500 V

Compact IP 54

VLT 5072-5102 380-500 V

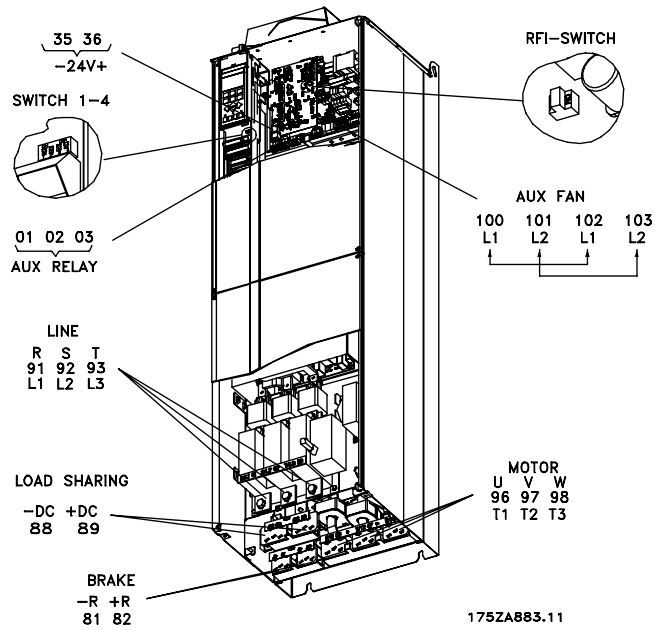
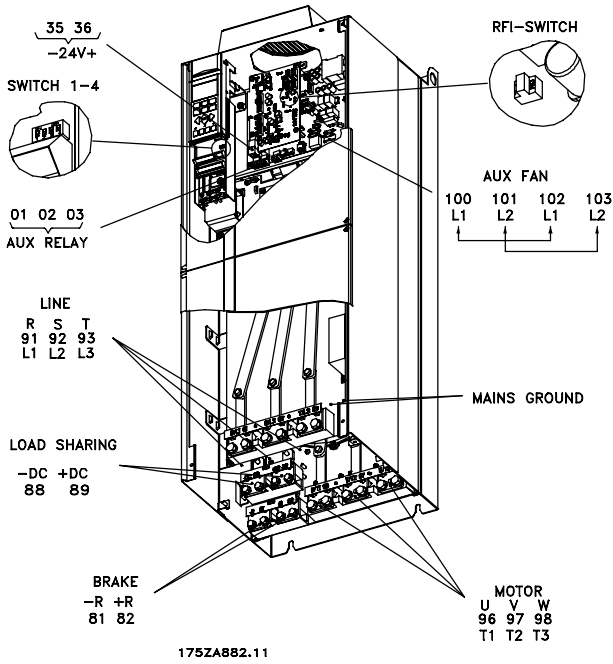

Compact IP 00 without disconnect and fuse
VLT 5122-5152 380-500 V

Compact IP 00 with disconnect and fuse
VLT 5202-5302 380-500 V

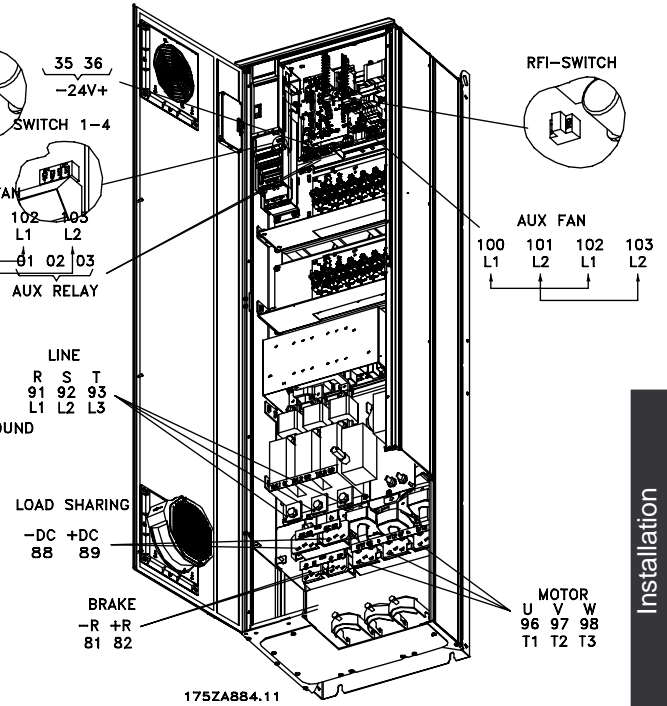
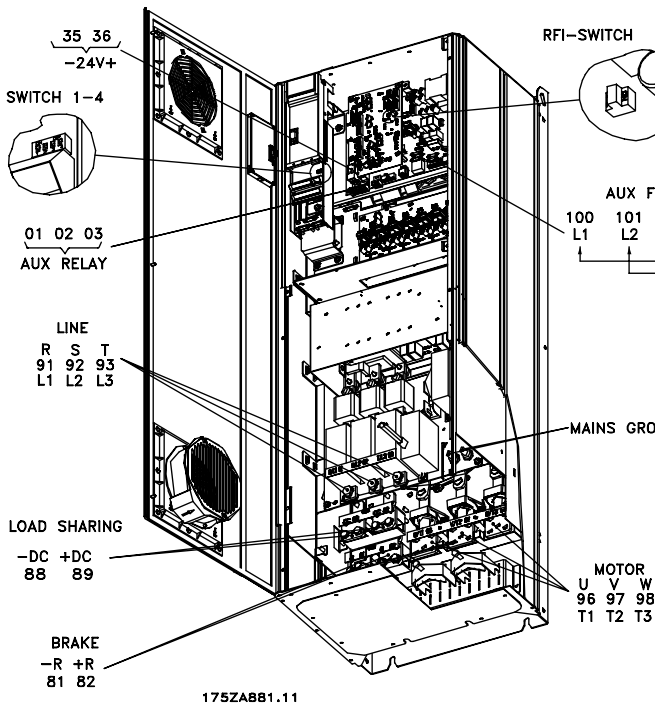

Compact IP 21/IP54 without disconnect and fuse
VLT 5122-5152 380-500 V

Compact IP 21/IP54 with disconnect and fuse
VLT 5202-5302 380-500 V

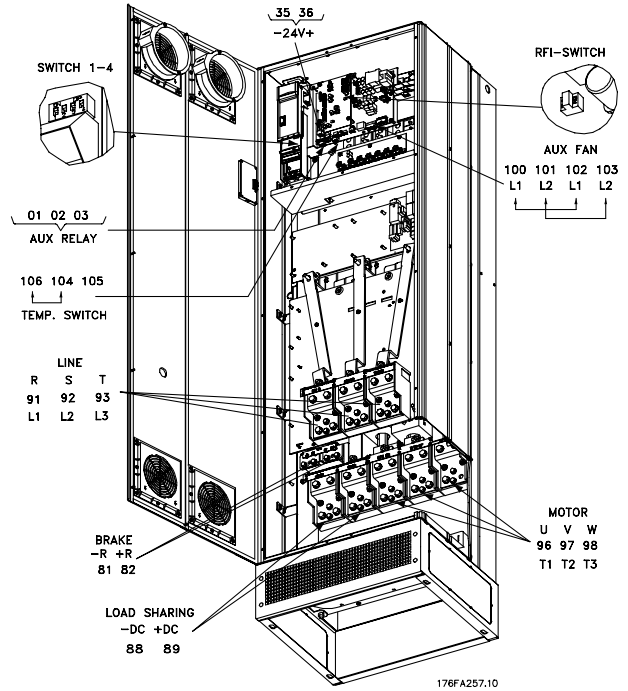
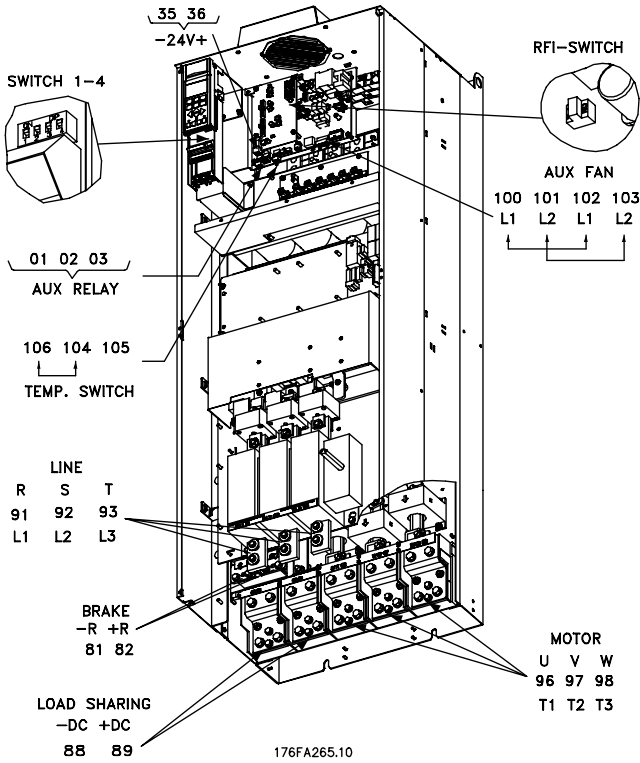

**Compact IP 21 / IP 54 without disconnect and fuse
VLT 5352-5502 380-500 V**

**Compact IP 00 with disconnect and fuse
VLT 5352-5502 380-500 V**

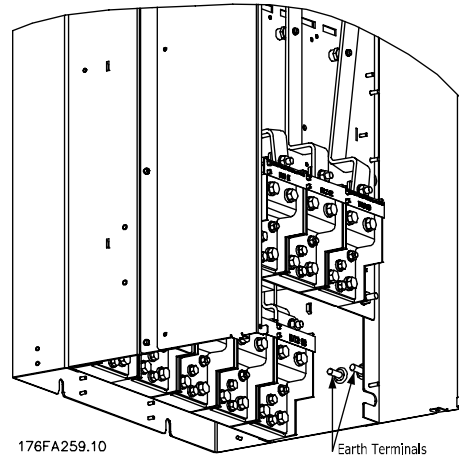
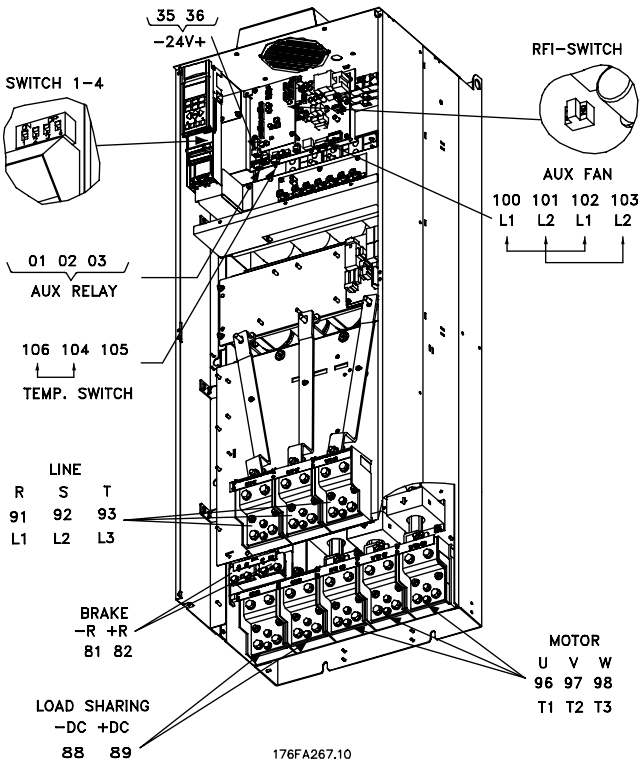

Position of earth terminals, IP 00

**Compact IP 00 without disconnect and fuse
VLT 5352-5502 380-500 V**

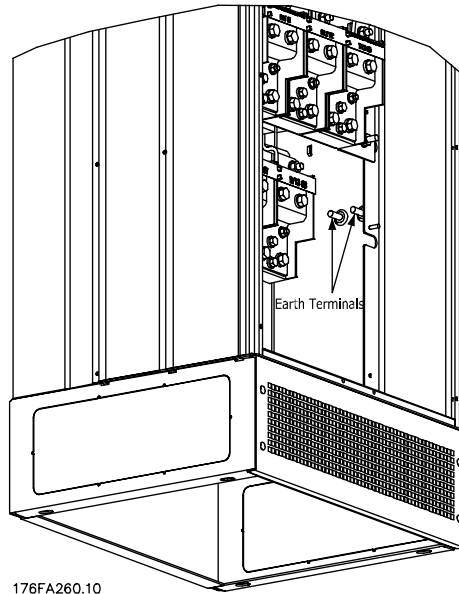

Position of earth terminals, IP 21 / IP 54

■ Electrical installation, power cables

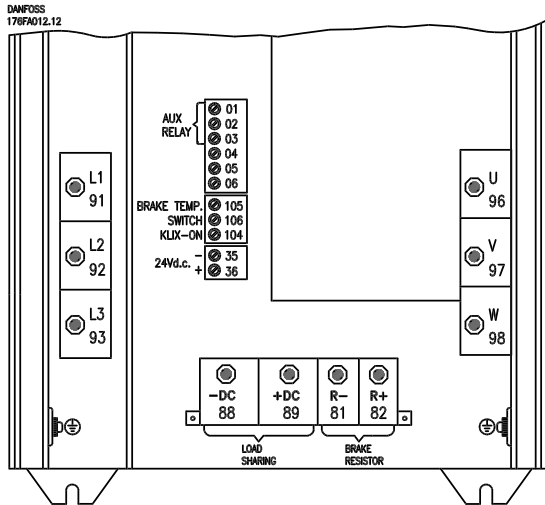
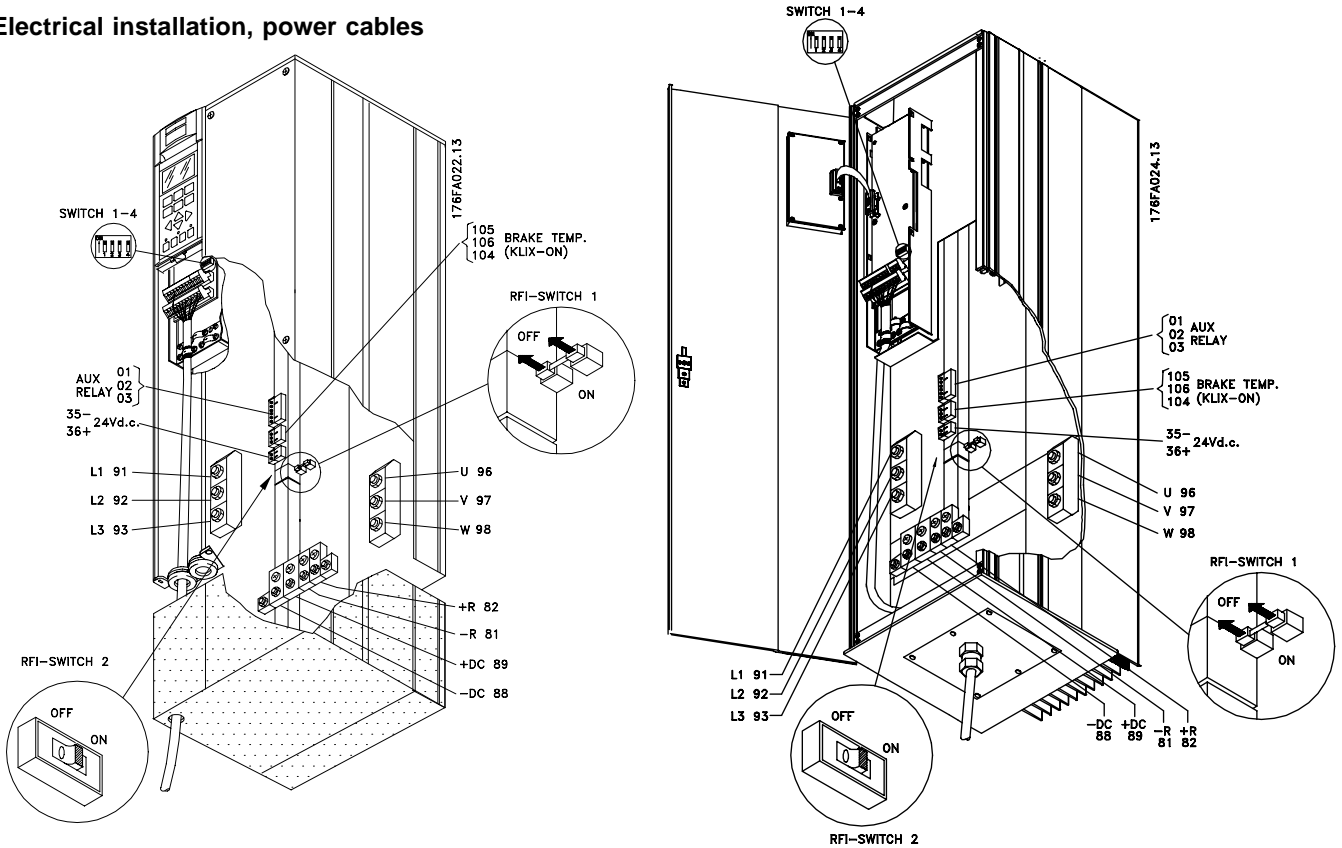

Compact IP 00/NEMA 1 (IP 20)
VLT 5032-5052 200-240 V

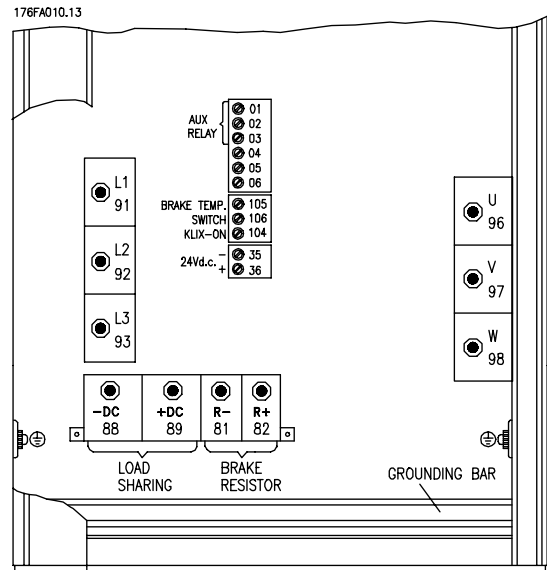

Compact IP 54
VLT 5032-5052 200-240 V

■ Installation of Control Cables

All terminals for the control cables are located under the protective cover of the frequency converter. The protective cover (see drawing) can be removed by means of a pointed object - a screwdriver or similar.

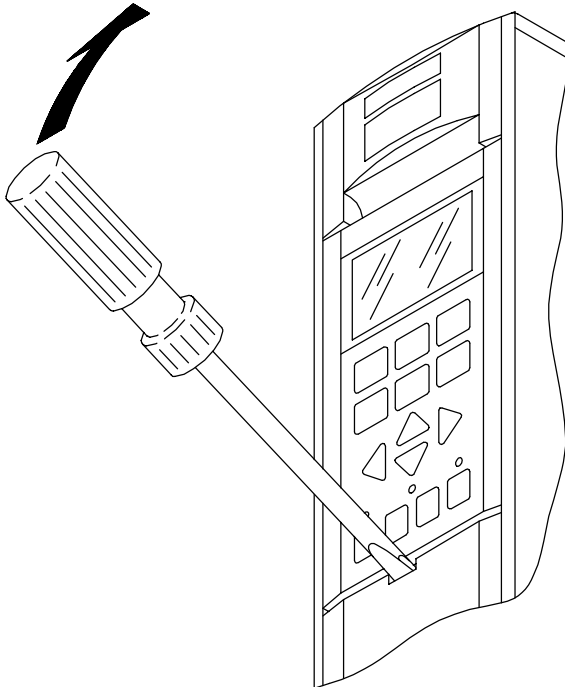

175ZA002.10

Once the protective cover has been removed, the actual EMC-correct installation can start. See drawings in the section, *EMC correct installation*.

Connection of shield:

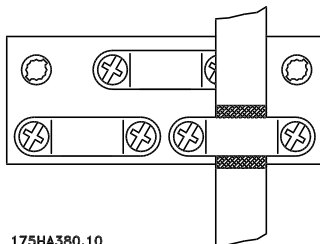

175HA380.10

■ Terminal Designation

No.	Function
04, 05	Relay output
12, 13	+24 VDC. Supply to digital inputs I _{max} : 200 mA.
20	No connection when external 24 VDC supply is used and DIP SW4 off
16	GND for digital inputs (External 24 VDC connection)
17	Digital Input 1. Parameter 300 [1] {RESET} ¹⁾
18	Digital Input 2. Parameter 301 [7] {FREEZE REFERENCE} ¹⁾
19	Digital Input 3. Parameter 302 [1] {START} ¹⁾
27	Digital Input 4. Parameter 303 [1] {REVERSING} ¹⁾
29	Digital Input 5. Parameter 304 [0] {COASTING STOP} ¹⁾
32	Digital Input 6. Parameter 305 [5] {JOG} ¹⁾
33	Digital Input 7. Parameter 306 [11] {Set-up MSB / SPEED UP} ¹⁾
37	Digital Input 8. Parameter 307 [1] {Set-up LSB / SPEED DOWN} ¹⁾
39	Digital Input. Hardware Coast. No parameter influence. Disable output stage.
26, 46	GND for analogue and digital outputs
42, 45	Digital Outputs for readout of speed, reference, current or torque
50	Analogue Outputs for readout of speed, reference, current or torque
55	+10 VDC supply for analogue reference inputs as external potentiometers, thermistor or KTY sensor. I _{max} <12 mA
53	GND for analogue reference inputs
54	Analogue reference input ±10 V
60	Analogue reference input 0/4 - 20 mA.
68, 69	RS 485 Interface, serial communication.
49	+5 VDC supply for encoder.
47	GND for supply for encoder
73	Channel A ²⁾
74	Channel A inverted ²⁾
75	Channel B ²⁾
76	Channel B inverted ²⁾
77	Zero pulse from encoder (Z)
78	Zero pulse from encoder inverted

1) Factory settings. If other functionalities see parameters 300 - 307

2) Usually for clockwise turning of encoder shaft.

Terminal 37 is a "Hardware Coast" input function for disabling the output stages (inverter). Terminal 37 cannot be disabled, handled or adjusted by any parameters. Terminal 37 must be pulled up to 24 V DC for the unit to work.

Installation of Control Cables

Tightening-up torque: 0.22 - 0.25 Nm
 Screw size: M2
 Screw driver type: 0.4 x 2.5 x 80 mm
 See *Earthing of Braided Screened/Armoured Control Cables* for correct earthing.

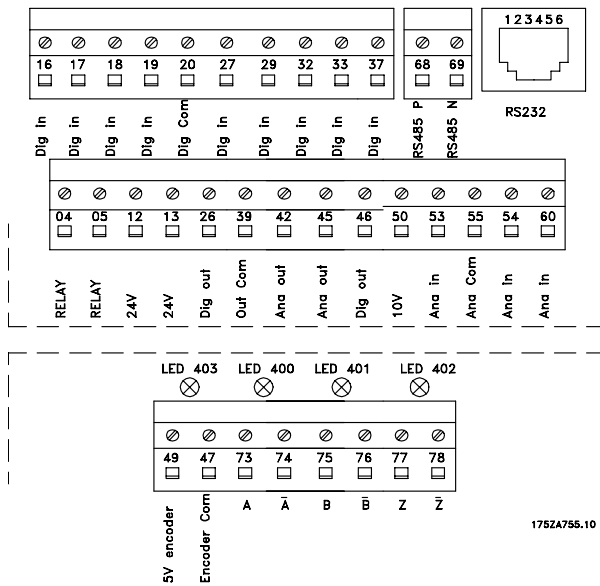

LEDs on encoder board:

- When all LEDs are ON the connection to encoder and encoder condition are OK.
- LED 403 OFF: 5 V supply missing
- LED 400 OFF: Channel A or inv. A missing or shortcircuited
- LED 401 OFF: Channel B or inv. B missing or shortcircuited
- LED 402 OFF: Channel Z or inv. Z missing or shortcircuited.

Feedback System

The feedback system is necessary when the drive is set to closed loop operation (Parameter 100 [1] or [5]). The VLT 5000 Flux accepts incremental encoders as feedback system from motor.

Connection of encoder

VLT 5000 Flux supports most types of 4 channel + zero pulse incremental encoders as feedback device.

Power supply: 5 V DC max 250 mA (Encoder power consumption max 0.75 watt).
 Max cable length (according to RS422 spec) < 150 m. If longer cables are used, please contact Danfoss Drives.

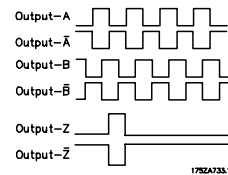

Typical impulse pattern from an incremental encoder

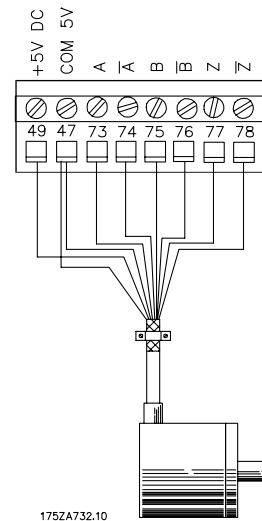

Basic encoder connection

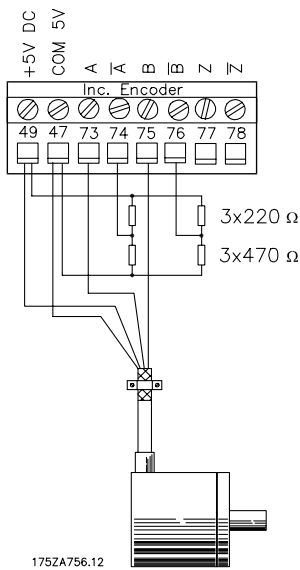

175ZA756.12

If the encoder has no inverted outputs, the encoder cable can only have a length of max 3 meter. The encoder input must then be terminated as shown.

The encoder surveillance circuit must be switched off in parameter 350 [0].

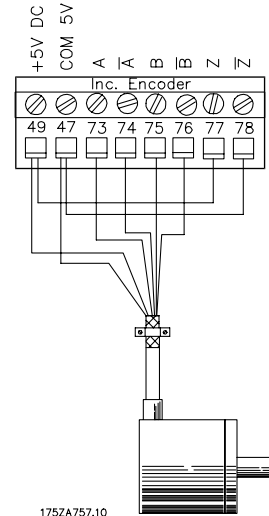

175ZA757.10

If the encoder has no zero pulse, and the encoder monitor is enabled (parameter 350), the inputs 77 and 78 must be terminated.

■ Electrical installation

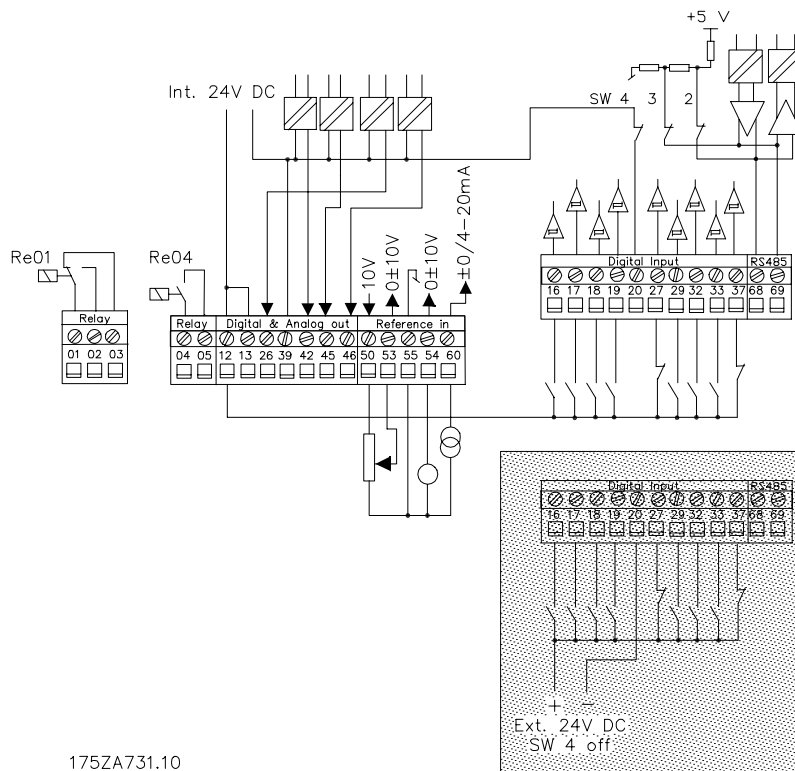

175ZA731.10

Regarding programming of the digital and analog inputs and outputs, see parameter group 300.

■ Bus connection RS 485

The serial bus connection is connected to terminals 68/69 of the frequency converter (signals P and N) in

accordance with the RS 485 (2-wire) norm. Signal P is the positive potential (TX+,RX+), while signal N is the negative potential (TX-,RX-).

If more than one frequency converter is to be connected to a given master, use parallel connections.

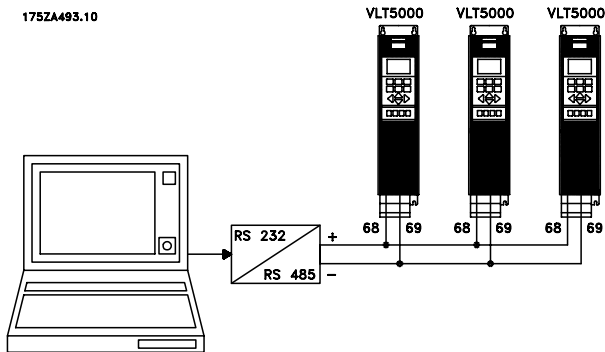

In order to avoid potential equalizing currents the circuit driving terminals 68 and 69 are connected to the VLT chassis ground via a 100Ω resistor.

Bus termination

The bus must be terminated by a resistor network at both ends. For this purpose, set switches 2 and 3 on the control card for "ON", see *Switches 1-4*.

■ DIP Switches 1-4

The DIP switch is located on the control card. It is used for serial communication, terminals 68 and 69. The switching position shown is the factory setting.



Switch 1 must always be open (off).
Switches 2 and 3 are used for terminating an RS 485 interface, serial communication.
Switch 4 is used for separating the common potential for the internal 24 V DC supply from the common potential of the external 24 V DC supply.



NB!

Please note that when Switch 4 is in position "OFF", the external DC supply is galvanically isolated from the frequency converter.

■ Bus Connection RS 232

The purpose of the RS 232 is to enable communication between a PC and a frequency converter. With this communication it is possible to monitor, programme and control the frequency converter.

However, it is not possible to use the RS 232 concurrently with the RS 485. When using one of the buses, the other must be disconnected,

ie. when using eg. the RS 232, the RS 485 plug must be removed from the board.

Hardware connection of the RS 232:

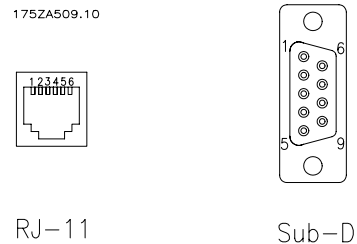

VLT signal		PC signal	
Request to send	1	8	Clear to send
Transmit data	2	2	Receive Data
Signal Ground	3	5	Signal Ground
Chassis Ground	4	NC	Chassis Ground
Receive Data	5	3	Transmit Data
Clear to send	6	7	Request to send

(NC = no connection)

Pin 1 is connected to pin 6 on the control card, which results in the PC receiving a "Clear to Send" when it sends a "Request to Send".

Pin 1 is the left terminal on RJ-11.

Communication cable with an RJ-11 male plug in both ends and an adaptor between RJ-11 and Sub-D 9 connector (for PC connection) (175Z3217).

■ Connection examples

■ 2-wire start/stop

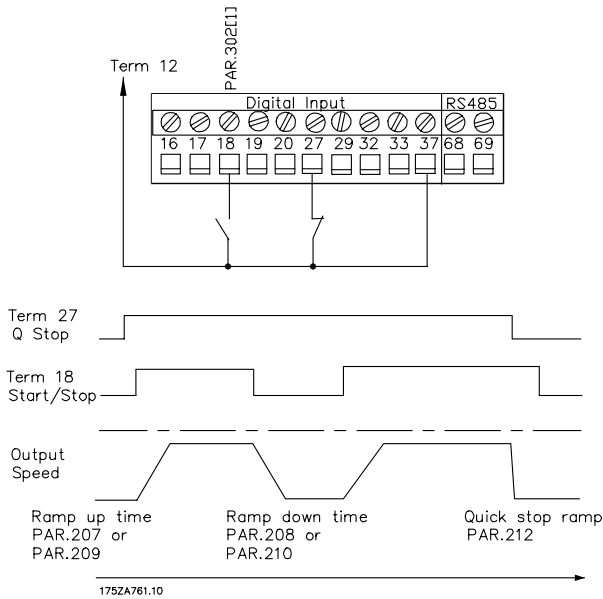

Start - Stop (18) Parameter 302 *Start* [1]
 Quick Stop (27) Parameter 304 *Coasting Stop inverted* [0]
 Ramp up Time Parameter 207/209 [0.01...3600]
 Ramp down Time Parameter 208/210 [0.01...3600]
 Quick Stop Ramp Parameter 212 [0.01...3600]

Start (18) Parameter 302 *Pulse Start* [2]
 Stop (16) Parameter 300 *Stop inverted* [2]
 Jog Parameter 305 *Jog* [5]
 Ramp up Time Parameter 207/209 [0.01...3600]
 Ramp down Parameter 208/210 [0.01...3600]
 Time Parameter 213 [0.0...Parameter 202]
 Jog Speed Parameter 211 [0.01... 3600]
 Jog Ramp Time Parameter 304 *Coasting Stop inverted* [0]

■ Setup change

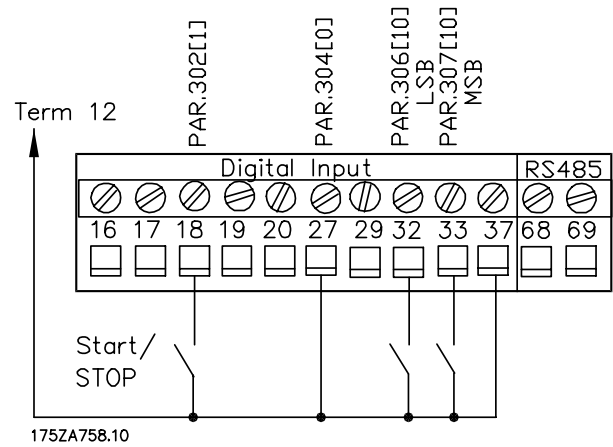

Start - Stop (18) Parameter 302 *Start* [1]
 Active Set-up Parameter 004 *Multi-setup* [5]
 Set-up MSB Parameter 306 [11]
 Set-up LSB Parameter 307 [11]

■ Pulse start/stop

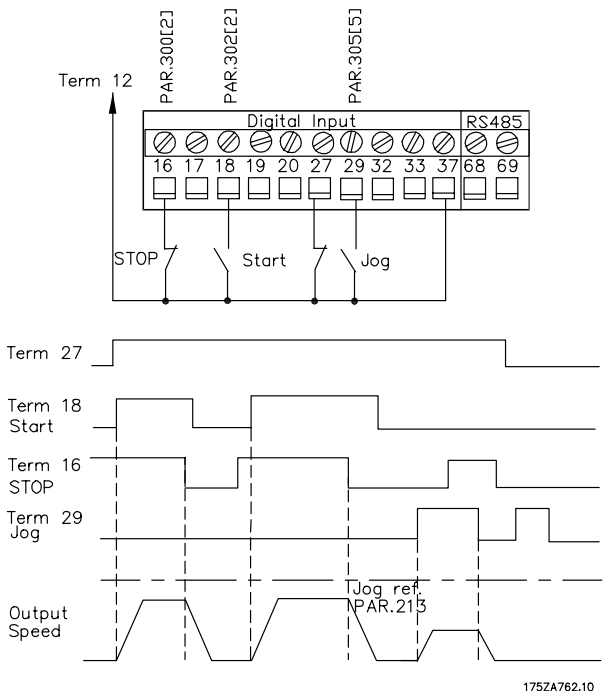

	Term 33	Term 32
Select setup 1	0	0
Select setup 2	1	0
Select setup 3	0	1
Select setup 4	1	1

■ Digital speed up/down

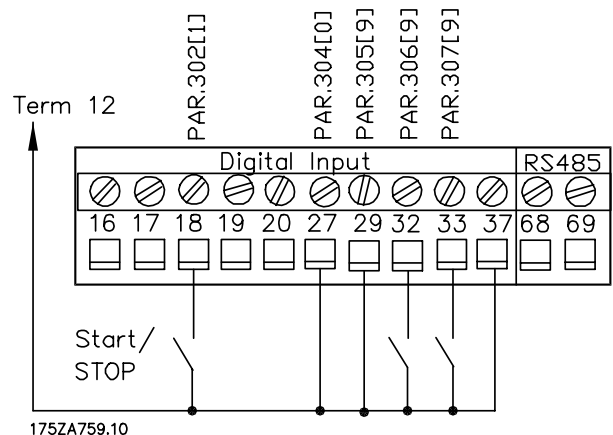

Start - Stop (18) Parameter 302 *Start* [1]
 Freeze reference Parameter 305 *Freeze reference* [9]
 Higher speed Parameter 306 *Speed up* [9]
 Lower speed Parameter 307 *Speed down* [9]
 Ramp up time Parameter 209 [0.01...3600]
 Ramp down time Parameter 210 [0.01...3600]

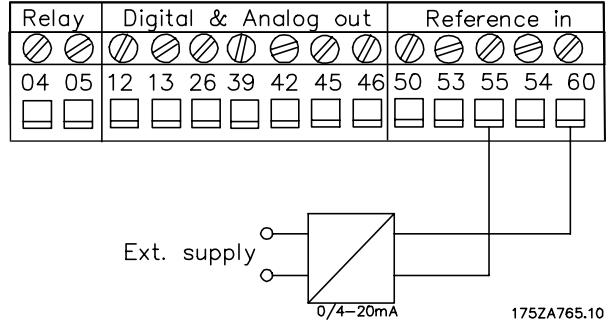

■ Potentiometer reference

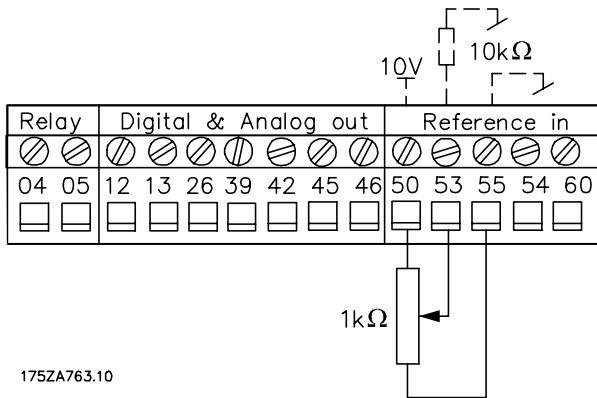

Analogue input (53) Parameter 308 *Reference* [1]
 Min Scaling (53) Parameter 309 [0.0...10.0 V]
 Max Scaling (53) Parameter 310 [Parameter 309...10.0 V]

■ Two-wire transmitter

Input Ref 0/4-20 mA Parameter 314 *Reference* [1]
 Min Scaling (60) Parameter 315 [0.0...20.0 mA]
 Max Scaling (60) Parameter 316 [Parameter 315...20.0 mA]

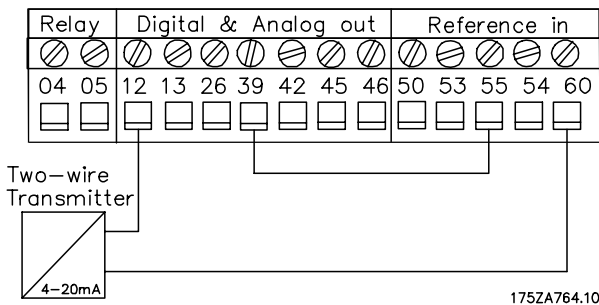

■ Electrical installation - EMC precautions

The following is a guideline to good engineering practice, when installing drives. Following these guidelines is advised, where compliance with EN 61000-6-3, EN 61000-6-4, EN 55011 or EN 61800-3 *First environment* is required. If the installation is in EN 61800-3 *Second environment*, i.e. industrial networks or in an installation that has its own transformer, it is acceptable to deviate from these guidelines. It is however not recommended. See also *CE labelling, Emission and EMC test results* under special conditions in the Design Guide for further details.

Good engineering practice to ensure EMC-correct electrical installation:

- Use only braided screened/armoured motor cables and braided screened/armoured control cables. The screen should provide a minimum coverage of 80%. The screen material must be metal, not limited to but typically copper, aluminium, steel or lead. There are no special requirements for the mains cable.
 - Installations using rigid metal conduits are not required to use screened cable, but the motor cable must be installed in conduit separate from the control and mains cables. Full connection of the conduit from the drive to the motor is required. The EMC performance of flexible conduits varies a lot and information from the manufacturer must be obtained.
 - Connect the screen/armour/conduit to earth at both ends for motor cables as well as for control cables. In some cases, it is not possible to connect the screen in both ends. In these cases, it is important to connect the screen at the frequency converter. See also *Earthing of braided screened/armoured control cables*.
 - Avoid terminating the screen/armour with twisted ends (pigtailed). Such a termination increases the high frequency impedance of the screen, which reduces its effectiveness at high frequencies. Use low impedance cable clamps or EMC cable glands instead.
 - It is important to ensure good electrical contact between the mounting plate on which the frequency converter is installed and the metal chassis of the frequency converter. However, this does not apply to IP 54 units as they are designed for wall-mounting and VLT 5122-5552 380-500 V, 5042-5352 525-690 V and VLT 5032-5052 200-240 V in IP20/NEMA 1 enclosure and IP 54/NEMA 12 enclosure.
 - Use starwashers and galvanically conductive installation plates to secure good electrical connections for IP00 and IP20 installations.
- Avoid using unscreened/unarmoured motor or control cables inside cabinets housing the drive(s), whenever this can be avoided.
 - An uninterrupted high frequency connection between the frequency converter and the motor units is required for IP54 units.

The illustration shows an example of an EMC-correct electrical installation of an IP 20 frequency converter; the frequency converter has been fitted in an installation cabinet with an output contactor and connected to a PLC, which in this example is installed in a separate cabinet. In IP 54 units and VLT 5032-5052, 200-240 V in IP20/IP21/NEMA 1 enclosure screened cables are connected by using EMC conduits to ensure proper EMC performance. See illustration. Other ways of making the installation may have as good an EMC performance, provided the above guidelines to engineering practice are followed.

Please note, that when the installation is not carried through according to the guideline as well as when unscreened cables and control wires are used, some emission requirements are not complied with, although the immunity requirements are fulfilled. See the section *EMC test results* in the Design Guide for further details.

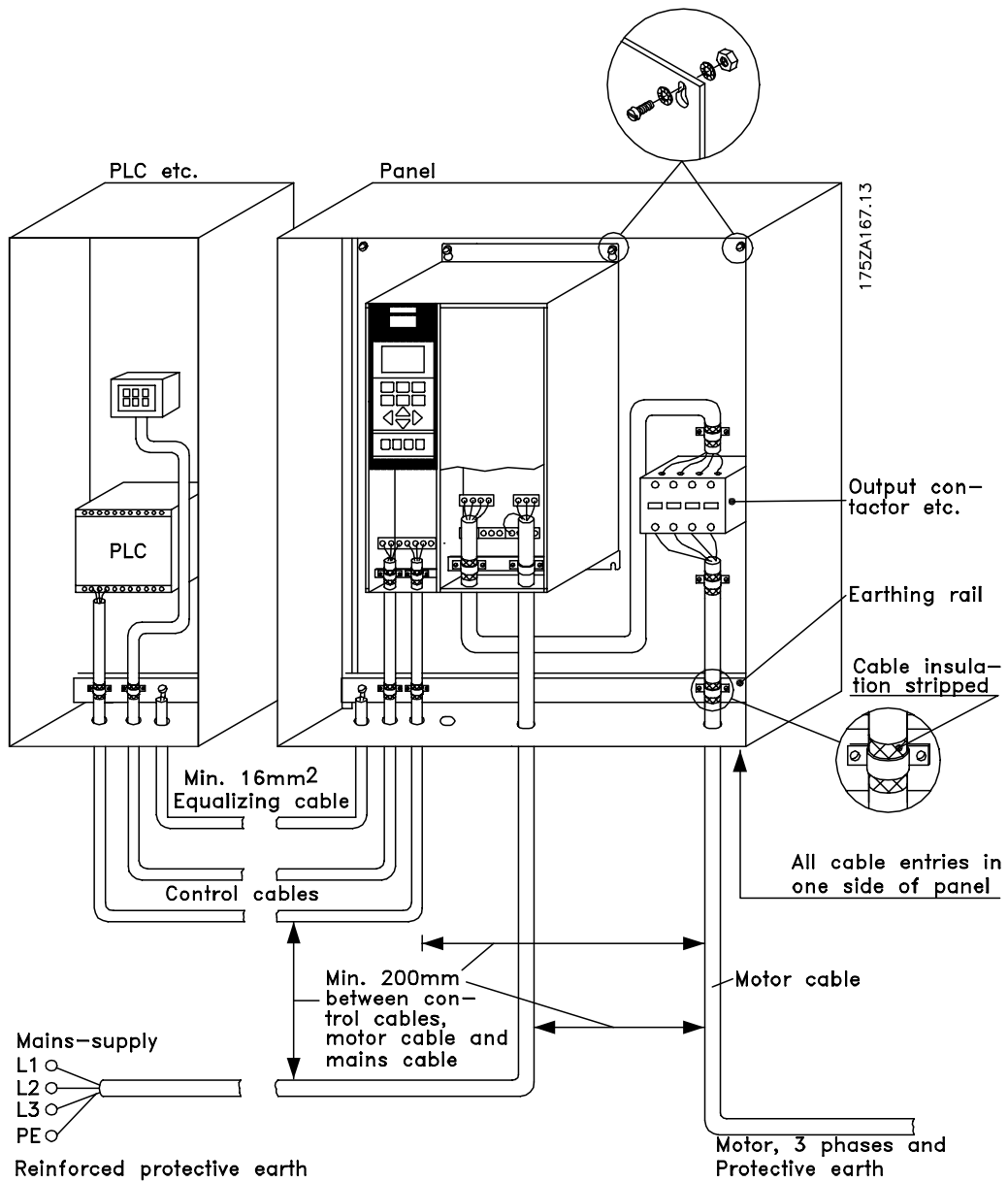

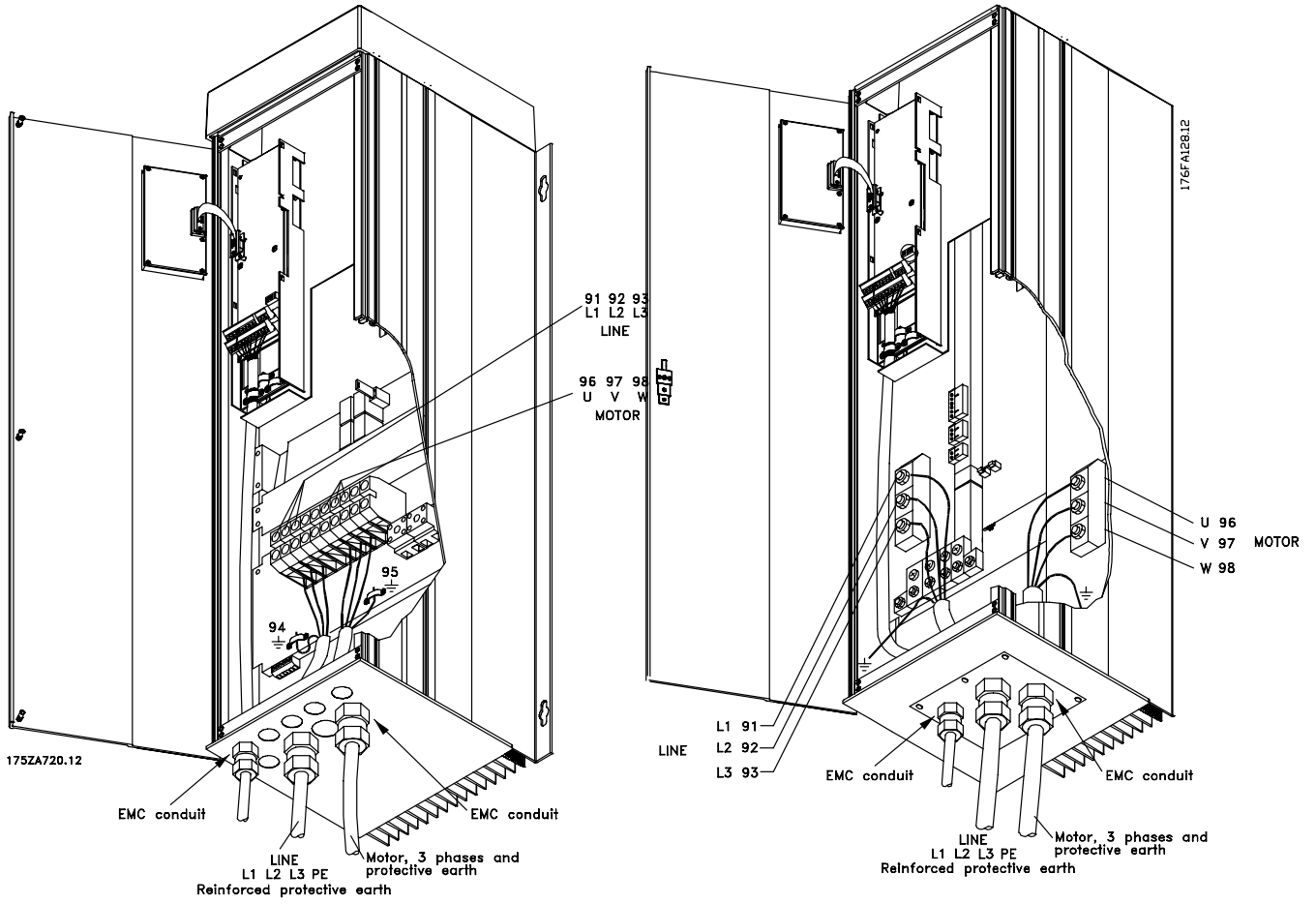

■ Use of emc-correct cables

Braided screened/armoured cables are recommended to optimise EMC immunity of the control cables and the EMC emission from the motor cables.

The ability of a cable to reduce the in- and outgoing radiation of electric noise depends on the transfer impedance (Z_T). The screen of a cable is normally designed to reduce the transfer of electric noise; however, a screen with a lower transfer impedance (Z_T) value is more effective than a screen with a higher transfer impedance (Z_T).

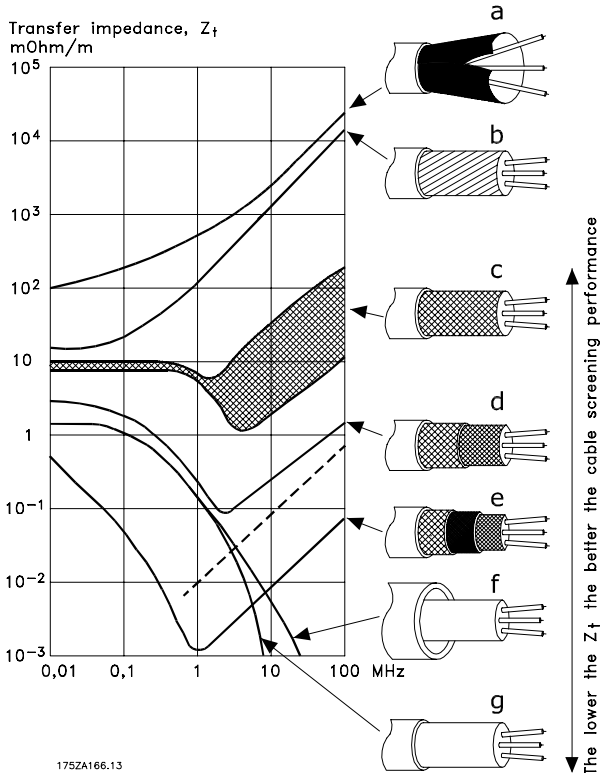

175ZA166.13

Transfer impedance (Z_T) is rarely stated by cable manufacturers, but it is often possible to estimate transfer impedance (Z_T) by assessing the physical design of the cable.

Transfer impedance (Z_T) can be assessed on the basis of the following factors:

- The conductivity of the screen material.
- The contact resistance between the individual screen conductors.
- The screen coverage, i.e. the physical area of the cable covered by the screen - often stated as a percentage value.
- Screen type, i.e. braided or twisted pattern.

Aluminium-clad with copper wire.

Twisted copper wire or armoured steel wire cable.

Single-layer braided copper wire with varying percentage screen coverage.

This is the typical Danfoss reference cable.

Double-layer braided copper wire.

Twin layer of braided copper wire with a magnetic, screened/armoured intermediate layer.

Cable that runs in copper tube or steel tube.

Lead cable with 1.1 mm wall thickness.

The lower the Z_T the better the cable screening performance

■ **Electrical installation - earthing of control cables**

Generally speaking, control cables must be braided screened/armoured and the screen must be connected by means of a cable clamp at both ends to the metal cabinet of the unit.

The drawing below indicates how correct earthing is carried out and what to be done if in doubt.

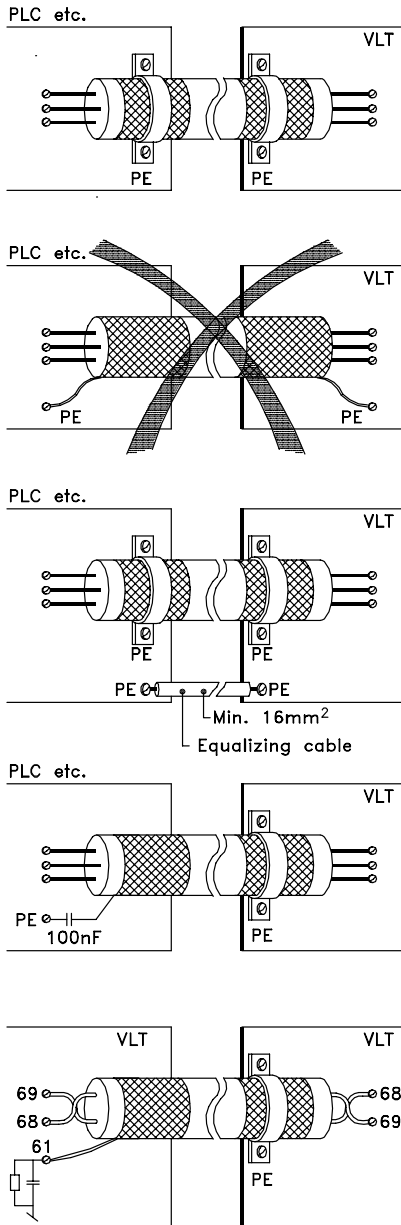

175ZA165.11

Correct earthing

Control cables and cables for serial communication must be fitted with cable clamps at both ends to ensure the best possible electrical contact

Wrong earthing

Do not use twisted cable ends (pigtails), since these increase the screen impedance at high frequencies.

Protection with respect to earth potential between PLC and VLT

If the earth potential between the frequency converter and the PLC (etc.) is different, electric noise may occur that will disturb the whole system. This problem can be solved by fitting an equalising cable, to be placed next to the control cable. Minimum cable cross-section: 16 mm².

For 50/60 Hz earth loops

If very long control cables are used, 50/60 Hz earth loops may occur. This problem can be solved by connecting one end of the screen to earth via a 100nF capacitor (keeping leads short).

Cables for serial communication

Low-frequency noise currents between two frequency converters can be eliminated by connecting one end of the screen to terminal 61. This terminal is connected to earth via an internal RC link. It is recommended to use twisted-pair cables to reduce the differential mode interference between the conductors.

■ RFI switch

Mains supply isolated from earth:

If the frequency converter is supplied from an isolated mains source (IT mains), the RFI switch is recommended to be turned off (OFF). In case optimum EMC performance is needed, parallel motors are connected or the motor cable length is above 25 m, it is recommended to set the switch in ON position. In OFF position, the internal RFI capacities (filter capacitors) between the chassis and the intermediate circuit are cut off to avoid damage to the intermediate circuit and to reduce the earth capacity currents (according to IEC 61800-3).

Please also refer to the application note *VLT on IT mains*, MN.90.CX.02. It is important to use isolation monitors that are capable for use together with power electronics (IEC 61557-8).



NB!:

The RFI switch is not to be operated with mains connected to the unit. Check that the mains supply has been disconnected before operating the RFI switch.



NB!:

Open RFI switch is only allowed at factory set switching frequencies.



NB!:

The RFI switch disconnects the capacitors galvanically to ground.

The red switches are operated by means of e.g. a screwdriver. They are set in the OFF position when they are pulled out and in ON position when they are pushed in. Factory setting is ON.

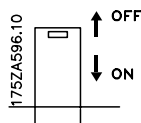

Mains supply connected to earth:

The RFI switch **must** be in ON position in order for the frequency converter to comply with the EMC-standard.

Position of RFI switches

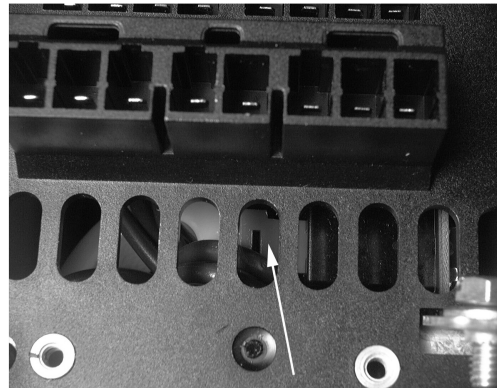

175ZA649.10

Bookstyle IP 20

VLT 5001 - 5006 200 - 240 V

VLT 5001 - 5011 380 - 500 V

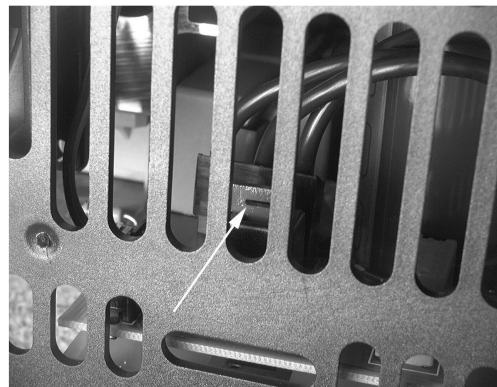

175ZA650.10

Compact IP 20/NEMA 1

VLT 5001 - 5006 200 - 240 V

VLT 5001 - 5011 380 - 500 V



Compact IP 20/NEMA 1
VLT 5008 200 - 240 V
VLT 5016 - 5022 380 - 500 V

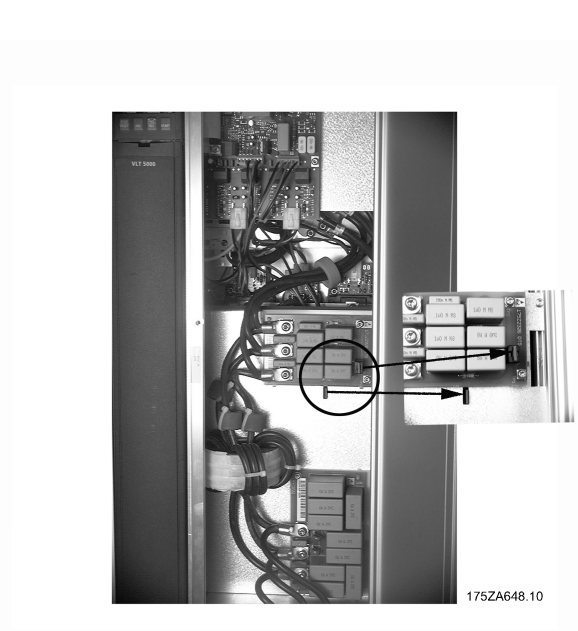

Compact IP 20/NEMA 1
VLT 5022 - 5027 200 - 240 V
VLT 5042 - 5102 380 - 500 V



Compact IP 20/NEMA 1
VLT 5011 - 5016 200 - 240 V
VLT 5027 - 5032 380 - 500 V

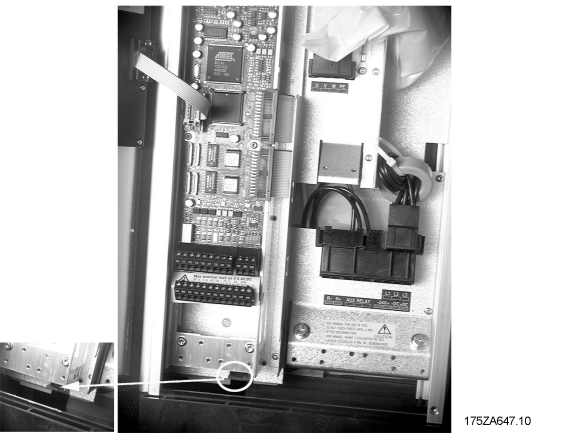

Compact IP 54
VLT 5001 - 5006 200 - 240 V
VLT 5001 - 5011 380 - 500 V



Compact IP 54
VLT 5008 - 5011 200 - 240 V
VLT 5016 - 5027 380 - 500 V

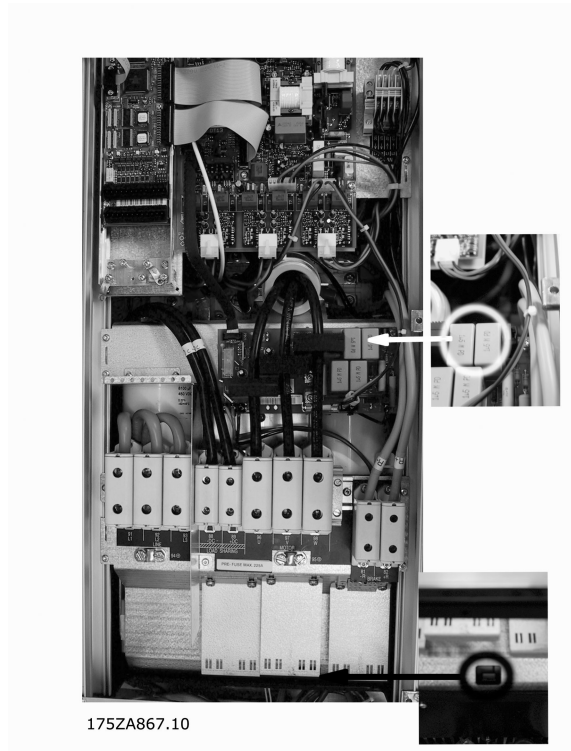

Compact IP 54
VLT 5072 - 5102 380 - 500 V

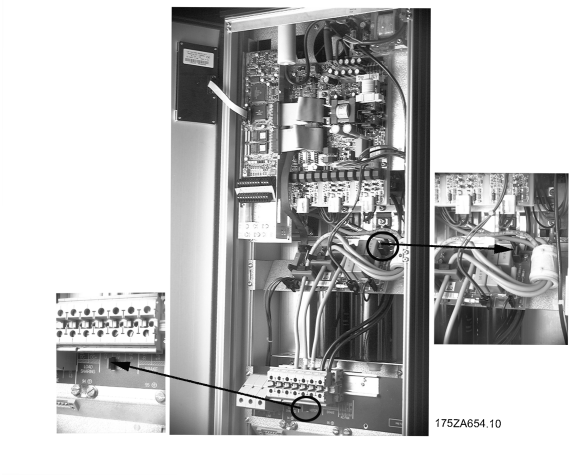

Compact IP 54
VLT 5016 - 5027 200 - 240 V
VLT 5032 - 5062 380 - 500 V

■ **Control panel (LCP)**

The front of the frequency converter features a control panel - LCP(Local Control Panel), which makes up a complete interface for operation and monitoring of the frequency converter.

The control panel is detachable and can - as an alternative - be installed up to 3 metres away from the frequency converter, e.g. on a front panel, by means of a mounting kit option.

The functions of the control panel can be divided into three groups:

- display
- keys for changing program parameters
- keys for local operation

All data are shown in a 4-line alpha-numeric display, which in normal operation is able to show 4 measurements and 3 operating conditions continuously. During programming, all the information required for quick, effective parameter Setup of the frequency converter will be displayed. Additional three LEDs for indicating voltage (power or 24 V external), warning and alarm.

All program parameters can be changed immediately from the control panel, unless this function has been blocked via parameter 018.

selected as the Active Setup in parameter 004 is shown. When programming another Setup than the Active Setup, the number of the Setup which is being programmed will appear to the right. This second Setup number will flash.

■ **LEDs**

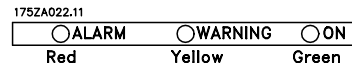

If certain threshold values are exceeded, the red alarm and/or yellow warning LED light(s) up together with a status and alarm text on the control panel.

The ON LED is activated when the frequency converter is connected to mains, or 24 V external supply; at the same time the rear lighting of the display will be on.

■ **Control keys**

The control keys are divided into functions. This means that the keys between display and indicator lamps are used for parameter Setup, including choice of display indication during normal operation.

■ **Display**

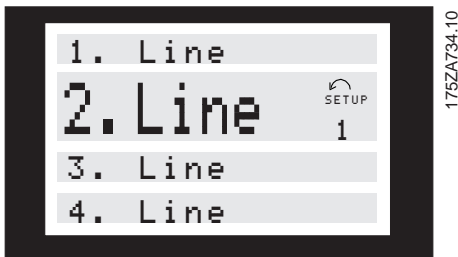

1st line shows up to 3 measurements continuously in normal operating status or a text which explains the 2nd line.

2nd line shows a measurement with related unit continuously, regardless of status (except in the case of alarm/warning).

3rd line is normally blank and is used in the menu mode to show the selected parameter number or parameter group number and name.

4th line is used in operating status for showing a status message text or in data change mode for showing the mode or value of the selected parameter.

An arrow indicates the direction of rotation of the motor. Furthermore, the Setup which has been

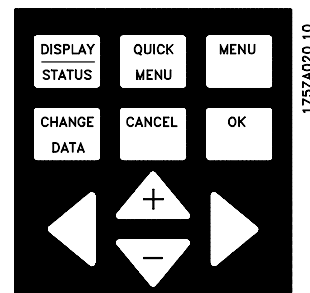

Parameter setup keys:

The frequency converter can be used for practically all assignments and offers a choice between two programming modes - a Menu mode and a Quick menu mode.

Menu mode provides access to all parameters. Quick menu mode takes the user through a few parameters which make it possible to easy start operating the frequency converter.

A change of a parameter will take effect and be visible both in the Menu mode and in the Quick menu mode.

[DISPLAY / STATUS] selects the mode of display or for changing back to Display mode from either the Quick menu mode or the Menu mode.

[QUICK MENU] programs the parameters that belong under the Quick menu mode. It is possible to switch directly between Quick menu mode and Menu mode.

[MENU] programs all parameters. It is possible to switch directly between Menu mode and Quick menu mode.

[CHANGE DATA] changes the parameter selected either in the Menu mode or the Quick menu mode.

[CANCEL] is used if a change of the selected parameter is not to be carried out.

[OK] confirms a change of the parameter selected.

[+/-] selects parameter and for changing the chosen parameter or for changing the read out in line 2.

[<>] is used for selecting group and to move the cursor when changing numerical parameters.

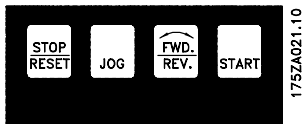

Local control keys:

[STOP / RESET] stops the motor connected or resets the frequency converter after a drop-out (trip). Can be selected via parameter 014 to be active or inactive. If stop is activated, line 2 will flash, and [START] must be activated.

[JOG] overrides the output frequency to a preset frequency while the key is kept down. Can be selected via parameter 015 to be active or inactive.

[FWD / REV] changes the direction of rotation of the motor. Forward or Reverse direction is indicated by means of the arrow on the display although only in Local. Parameter 016 selects the function to be active or inactive, depending on parameter 506.

[START] is used for starting the frequency converter after stop via the "Stop" key. Is always active, but cannot override a stop command given via the terminal strip.

NB!: If the keys for local control have been selected as active, they will remain active both when the speed has been set for *Local Control* and for *Remote Control* via parameter 002. [Fwd/rev] is only active in Local operation.



NB!:

If no external stop function has been selected and the [Stop] key has been selected as inactive, the motor can be started and can only be stopped by disconnecting the voltage to the motor.

■ Display read-out state

The display read-out state can be varied depending on whether the frequency converter is in normal operation or is being programmed.

■ Display mode

In normal operation, up to 4 different operating variables can be indicated continuously: In line 1 and 2 the present operating status or alarms, and warnings in line 4.

■ Display mode - selection of read-outstate

- Read-out state I:

This read-out state is default after starting up or after initialisation.

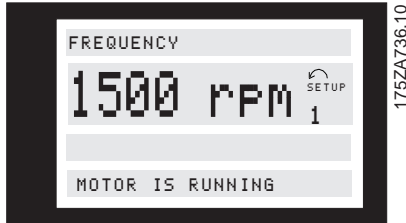

Line 2 shows the data value of an operating variable with related unit. Line 1 provides a text which explains line 2. In the example, the speed has been selected as variable via parameter 009. In normal operation mode variables can be read out by using the [+/-] keys.

- Read-out state II:

Switching between read-out states I and II is effected by pressing the [DISPLAY / STATUS] key in less than 1 sec.

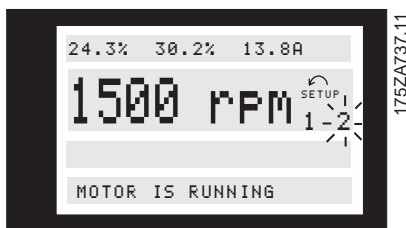

Data values for four operating values are shown at the same time, giving the related unit, cf. table. In the example, Reference, Torque, Current and Speed are selected as variables in the first and second line.

- Read-out state III:

Read-out state III can be shown as long as the [DISPLAY/STATUS] key is pressed. When the key is released, the system switches back to Read-out state II, unless the key is pressed for less than approx. 1 sec., in which case the system always reverts to Read-out state I.

This is where parameter names and units for operating variables in the first and second line are given - operating variable 2 remains unchanged.

Operating values 1.1 and 1.2 and 1.3 in the first line, and operating value 2 in the second line are selected via parameter 009, 010, 011 and 012.

- Display state IV:

This display state can be produced during operation if another setup is to be changed without stopping the frequency converter. This function is activated in parameter 005, *Programming Setup*.

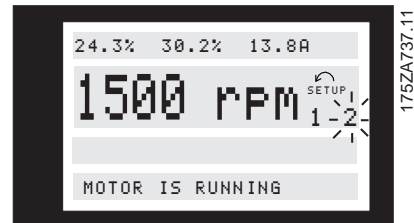

The selected programming setup number will flash to the right of the active setup.

The fourth line is showing status messages.

■ Structure for the Quick menu mode versus the Menu mode

Each named parameter is linked up with a number which is the same regardless of the programming mode. In Menu mode, the parameters are divided into groups, with the left digit of the parameter number indicating the parameter.

- The Quick menu takes the user through a number of parameters that may be enough to get the motor to run nearly optimally, if the factory setting for the other parameters takes the desired control functions into account, as well as the configuration of signal inputs/outputs (control terminals).
- Menu mode makes it possible to select and change all parameters at the user's option. However, some parameters will be "missing", depending on the choice of configuration (parameter 100).

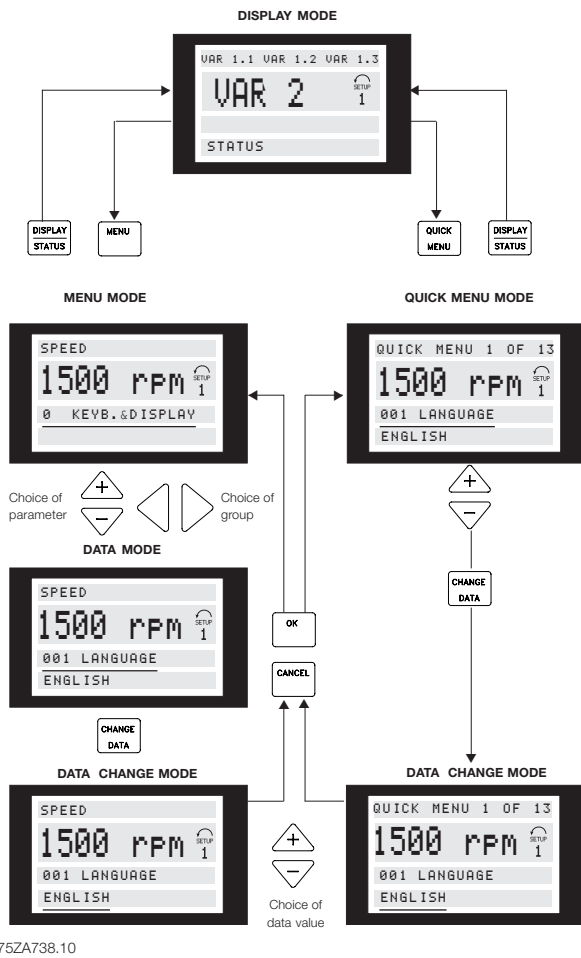

■ Quick Setup via Quick menu

The Quick Menu is used for set-up of closed loop applications.

The Quick Setup starts with pressing the [QUICK MENU] key, which brings out the following read-out on the display:

- Line 3: Parameter number and name
- Line 4: Status/value of the first parameter under Quick Setup

The first time the [Quick Menu] key is pressed after the unit has been switched on, the read-outs always start at pos. 1 - see table below.

The selection of a Quick Menu parameter is effected by means of the [+/-] keys. The following parameters are accessible:

Pos.:	No.:	Parameter:	Unit:
1	001	Language	
2	102	Motor output	[kW]
3	103	Motor Voltage	[V]
4	104	Motor frequency	[Hz]
5	105	Motor current	[A]
6	106	Motor Speed	[rpm]

7	107	Automatic Motor Adaptation AMA	
8	329	Encoder feedback	[ppm] pulses/rev
9	351	Encoder direction	
10	207	Ramp-up time 1	[sec]
11	208	Ramp-down time 1	[sec]
12	205	Max reference	[rpm]
13	417	Speed PID proportional Gain	
14	418	Speed PID integral Time	[ms]
15	221	Torque Limit Motor mode	[%]
16	222	Torque Limit Generating mode	[%]

■ Menu mode (Parameter setting)

The Menu mode is started by pressing the [MENU] key, which produces the following read-out on the display:

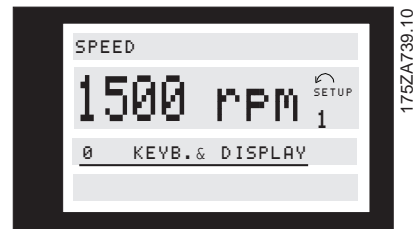

Line 3 shows the parameter group number and name.

Selection of parameter group is effected by means of the [<>] keys.

The following parameter groups are accessible:

Group no.	Parameter group:
0	Operation & Display
1	Load & Motor
2	References & Limits
3	Inputs & Outputs
4	Special functions
5	Serial communication
6	Technical functions
7	Application Options
8	Fieldbus Profile
9	Fieldbus Communication

When the desired parameter group has been selected, each parameter can be chosen by means of the [+/-] keys.

Line 3 shows the parameter number and name, while the status/value of the selected parameter are shown in line 4.

■ Changing data

The procedure for changing data is the same in Quick menu as Menu mode . Pressing the [CHANGE DATA] key gives access to changing the selected parameter, following the flashing underlining in line 4.

■ Changing a text value

If the selected parameter is a text value, the text value is changed by means of the [+/-] keys.



The bottom display line shows the text value that will be entered (saved) when acknowledgement is given [OK].

■ Change of group of numeric data values

If the chosen parameter represents a numeric data value, the chosen data value is changed by means of the [+/-] keys.

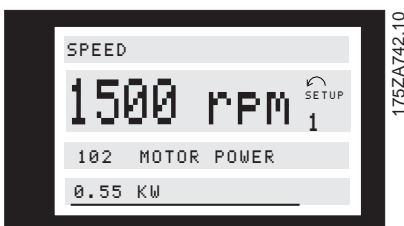
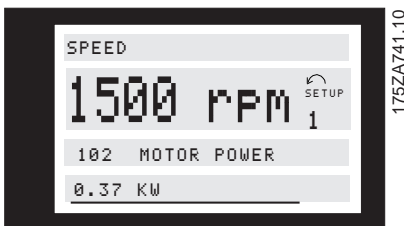

The chosen data value is indicated by the digit flashing. The bottom display line shows the data value that will be entered (saved) when signing off with [OK].

■ Infinitely variable change of numeric data value

If the chosen parameter represents a numeric data value, a digit is first selected by means of the [<->] keys.

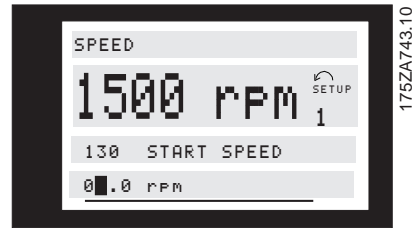

Then the chosen digit is changed infinitely variably by means of the [+/-] keys:



The chosen digit is indicated by the digit flashing. Line 4 shows the data value that will be entered (saved) when signing off with [OK].

■ Changing of data value, step-by-step

Certain parameters can be changed step by step or infinitely variably. This applies to Motor power (parameter 102), Motor voltage (parameter 103) and Motor frequency (parameter 104).

The parameters are changed both as a group of numeric data values and as numeric data values infinitely variably.

■ Read out and programming of indexed parameters

Parameters are indexed when placed in a rolling stack. Parameter 615 - 617 contain a historical log which can be read out. Choose the actual parameter, press the [CHANGE DATA] key and use the [+] and [-] keys to scroll through the log of values. During the read out line 4 of the display will flash.

If a bus option is mounted in the drive, the programming of parameter 915 - 916 needs to be carried through in the following way:

Choose the actual parameter, press the [CHANGE DATA] key and use the [+] and [-] keys to scroll through the different indexed values. To change the value of the parameter, select the indexed value and press the [CHANGE DATA] key. Using the [+] and [-] keys the value to be changed will flash. To accept the new setting, press [OK], to abort, press [CANCEL].

■ Initialisation to factory setting

The frequency converter can be initialised to factory settings in two ways.

Initialisation by parameter 620- Recommended initialisation

- Select parameter 620
- Press [CHANGE]
- Select "Initialisation"
- Press the [OK] key
- Cut off the mains supply and wait until the display turns off.
- Reconnect the mains supply - the frequency converter is now reset.

This parameter initialises all except:

500 Serial communication address
501 Baud rate for serial communication
601-605 Operating data
615-617 Fault logs

Manual initialisation

- Disconnect from mains and wait until the display turns off.
- Press the following keys at the same time:
[Display/status]
[Change data]
[OK]
- Reconnecting the mains supply while pressing the keys.
- Release the keys
- The frequency converter has now been programmed for the factory setting.

This parameter initialises all except:

600-605 Operating data

**NB!:**

Settings for serial communication and fault logs are reset.

Local and remote control

The frequency converter can be operated manually (Local control) or remotely (Remote control). The

following is a list of the functions/commands given via the control panel, the digital inputs or the serial communication port in the two situations (modes).

Control Command	Operation Site		
	Remote FC Profile	Local	Local Local mixed
LCP start/stop	X ¹⁾	X	X
LCP jog	X	X	X
LCP reset	X	X	X
LCP reversing	- ²⁾	X	-
Mains failure inverse	X	X	X
Reset	X	X	X
Ramp 2	X	X	X
Start	X	-	-
Stop inverse	X	-	X
Q stop inverse	X	-	X
DC brake inverse	X	-	X
Coast inverse	X	X (HW) ³⁾	X
Reversing	X	-	X
Jog	X	-	-
Freeze output	X	-	-
Freeze reference	X	-	-
Speed up	X	-	-
Speed down	X	-	-
Preset reference on	X	-	-
Preset reference LSB	X	-	-
Preset reference MSB	X	-	-
Catch up	X	-	-
Slow down	X	-	-
Relay 01/relay 04	X	X	X
Setup select LSB	X	X	X
Setup select MSB	X	X	X
Enable start forward	X	-	X
Enable start reverse	X	-	X
Speed Up/Setup Select LSB	X	X	X
Speed Down/Setup Select MSB	X	X	X
Latched Start	X	-	-
Start Reverse	X	-	X

1)" X" Means that the command is available

2) "-" Means that the command is NOT available

3) Terminal 37

■ Handling of single references

Using a single reference, only one active reference signal is connected, either in the form of an external or in the form of a preset (internal) reference. The external reference can be voltage, current, frequency (pulse) or binary via the serial port. Two examples are given below of the way the single references are handled by the frequency converter.

Relay	Digital & Analog out	Reference in
04 05	12 13 26 39 42 45 46	50 53 55 54 60
<input type="checkbox"/>	<input type="checkbox"/>	<input type="checkbox"/>

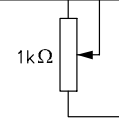

175ZA770.10

Single ref	External	Speed or torque reference term 53 (± 10 V) term 54 (± 10 V) term 60 (0/4 - 20 mA) term 17 or 29 (frequency) RS 485
	Preset references (parameter 215 - 218)	

Reference Handling

Example 1:

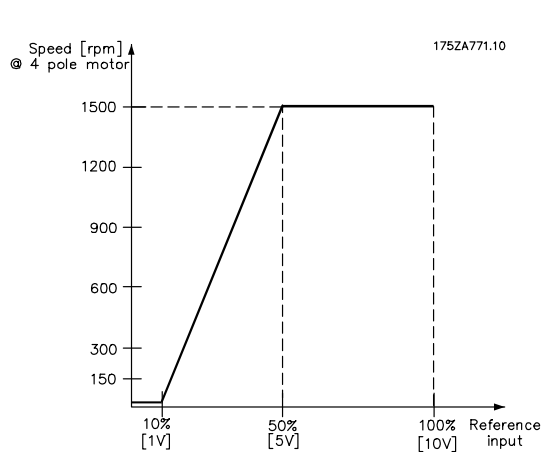

External reference signal = 1 V (min) - 5 V (max)
Reference = 20 - 1500 rpm
Configuration (parameter 100) - Speed control, closed loop.

Example 2:

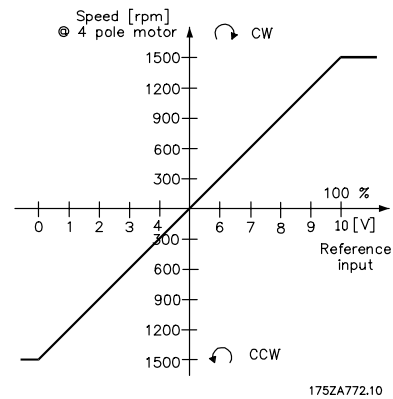

External reference signal = 0 V (min) - 10 V (max)
Reference = 1500 rpm ccw - 1500 rpm cw
Configuration (parameter 100) - Speed control, closed loop.

Example 3:

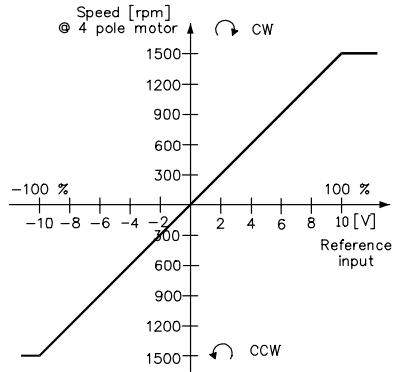

External reference signal from an external source =
 -10 V (1500 rpm ccw) - +10 V (1500 rpm cw)
 Configuration (parameter 100) = *Speed*
 control closed loop.

Ex 1	Configuration	Parameter 100 <i>Config Mode</i> [1]
	Reference term (53)	Parameter 308 [1]
	Min Ref signal (1V)	Parameter 309 [0.0...10.0 V]
	Max Ref signal (5 V)	Parameter 310 [Parameter 309...10.0 V]
	Ref Range	Parameter 203 <i>Min - Max</i> [0]
	Min Ref (20.000 rpm)	Parameter 204 [-100.000.000...Parameter 205]
	Max Ref (1500.000 rpm)	Parameter 205 [Parameter 204...100.000.000]
Ex 2	Configuration	Parameter 100 <i>Config Mode</i> [0 or 5]
	Reference term (53)	Parameter 308 [1]
	Min Ref signal (0V)	Parameter 309 [0.0...10.0 V]
	Max Ref signal (10 V)	Parameter 310 [Parameter 309...10.0 V]
	Ref Range	Parameter 203 <i>-Max - + Max</i> [1]
	Ref Type	Parameter 214 <i>Sum</i> [0]
	Max Ref (3000.000 rpm)	Parameter 205 [Parameter 204...100.000.000]
Ex 3	Preset Ref (-50%)	Parameter 215 [-100.00% -+100.00%]
	Output speed / direction	Parameter 200 <i>4500 rpm Both Direct</i> [1]
	Configuration	Parameter 100 <i>Config Mode</i> [1]
	Reference term (53)	Parameter 308 [1]
	Min Ref signal (0 V)	Parameter 309 [0.0...10.0 V]
	Max Ref signal (10 V)	Parameter 310 [Parameter 309...10.0 V]
	Ref Range	Parameter 203 <i>-Max - + Max</i> [1]
Ref Type	Parameter 214 <i>Sum</i> [0]	
Max Ref (3000.000 rpm)	Parameter 205 [Parameter 204...100.000.000]	
Preset Ref (0%)	Parameter 215 [-100.00% -+100.00%]	
Output speed / direction	Parameter 200 <i>4500 rpm Both Direct</i> [1]	
Catch-up/slow down and freeze reference via digital inputs 16. 17. 29. 32 or 33.		

■ Handling of multi-references

Multi-references are used where two or more reference signals are connected either as external or preset reference signals.

Parameter 214 can be combined in the following functions:

- Sum
- Relative
- External/Preset

List of handling of multi-references

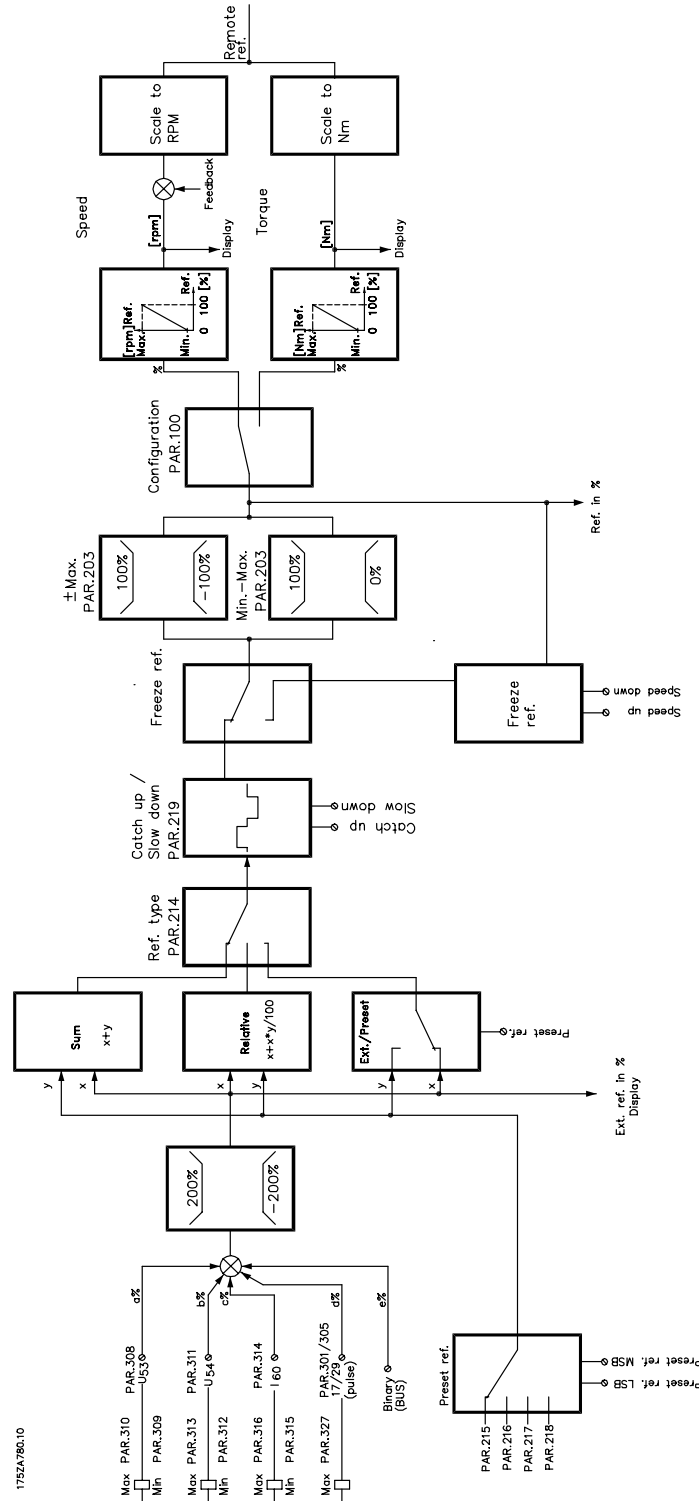

■ Programming of stop at torque limit

In applications with an external electro-mechanical brake, such as hoisting applications, it is possible to stop the frequency converter via a 'standard' stop command, while at the same time activating the external electro-mechanical brake.

The example below illustrates the programming of frequency converter connections.

The external brake can be connected to relay 01 or 04, see *Control of mechanical brake*. Program terminal 27 to *Coasting stop, inverse* [0] or *Reset and coasting stop, inverse* [1], as well as terminal 46 to *Torque limit and stop* [27].

Description:

If a stop command is active via terminal 18 and the frequency converter is not at the torque limit, the motor will ramp down to 0 rpm.

If the frequency converter is at the torque limit and a stop command is activated, terminal 46 *Output* (programmed to *Torque limit and stop* [27]) will be activated. The signal to terminal 27 will change from 'logic 1' to 'logic 0' and the motor will start coasting.

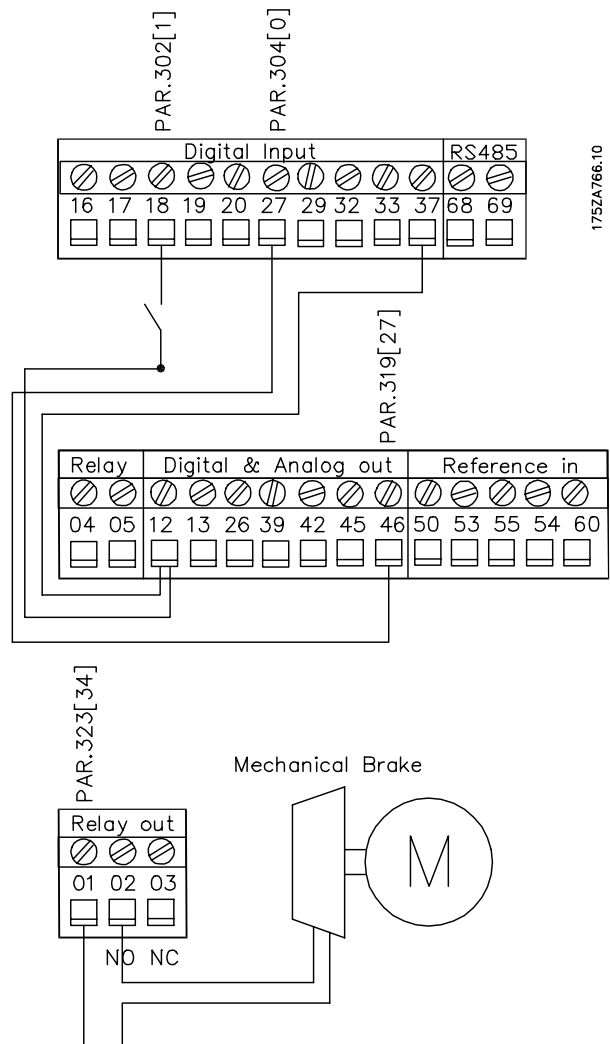

1752A766.10

- Start/stop via terminal 18.
Parameter 302 = *Start* [1].
- Quickstop via terminal 27.
Parameter 304 = *Coasting stop, inverse* [0].
- Terminal 46 Output
Parameter 319 = *Torque limit and stop* [27].
- Terminal 01 Relay output
Parameter 323 = *Mechanical brake control* [32].

■ **Dynamic brake function(Brake resistor)**

The brake function is to limit the voltage in the intermediate circuit when the load drives the motor and the power enters the intermediate circuit. The dynamic brake is a chopper circuit with the connection of an external brake resistor.

The brake is protected against short-circuiting of the brake resistor, and the brake transistor is monitored to ensure that short-circuiting of the transistor is detected. By using a relay/digital output, the latter can be used for protecting the brake resistor against overloading in connection with a fault in the frequency converter. In addition, the brake makes it possible to read out the momentary power and the mean power for the latest 120 seconds, as well as to monitor that the power energizing does not exceed a monitoring limit selected in parameter 402. Parameter 403 selects the function to be carried out when the power transmitted to the brake resistor exceeds the limit set in parameter 402.

NB! Monitoring of the brake power is not a safety function; a thermal switch is required for that purpose. The brake resistor circuit is not earth leakage current protected.

example and formula apply to VLT 5000 only. The peak power can be calculated on the basis of the highest brake resistance required for braking:

$$P_{PEAK} = P_{MOTOR} \times M_{BR(\%)} \times \eta_{MOTOR} \times \eta_{VLT} [W]$$

where $M_{BR(\%)}$ is a percentage of the rated torque. The brake resistance is calculated as follows:

$$R_{REC} = \frac{U^2 DC}{P_{PEAK}} [\Omega]$$

The brake resistance depends on the intermediate circuit voltage (UDC).

With VLT 5000 frequency converters that have a mains voltage of 3 x 380-500 Volts, the brake will be active at 822 Volts (UDC); if the frequency converter has a mains voltage of 3 x 200-240 Volts, the brake will be active at 397 Volts (UDC).

NB! The brake resistor used must be rated to 850 Volts or 430 Volts.

R_{REC} is the resistance recommended by Danfoss, i.e. one that guarantees the user that the frequency converter is able to brake at the highest braking torque (M_{br}) of 160%.

η_{motor} is typically at 0.90, while η_{VLT} is typically at 0.98. For 200 V and 500 V frequency converters, respectively, R_{REC} at 160% braking torque can be written as:

$$R_{REC} = \frac{111.684}{P_{MOTOR}} [\Omega] @200V$$

$$R_{REC} = \frac{478.801}{P_{MOTOR}} [\Omega] @500V$$

$$R_{REC} = \frac{630.137}{P_{MOTOR}} [\Omega] @600V$$

P motor in kW.

NB! The max. brake resistance selected should have an ohmic value max. 10% lower than that recommended by Danfoss. If a brake resistor with a higher ohmic value is selected, the 160% braking torque will not be achieved and there is a risk that the frequency converter will cut out for safety reasons. For further information, please consult Brake Resistor Instruction MI.90.FX.YY.

■ **Selection of Brake Resistor**

In order to select the right brake resistor, it must be known how often to brake and by how much power braking is effected.

The resistor ED is an indication of the duty cycle at which the resistor is working.

The resistor ED is calculated as follows:

$$ED (duty\ cycle) = \frac{t_b}{T_{cycle}}$$

where t_b is the braking time in seconds and T cycle is the total cycle time.

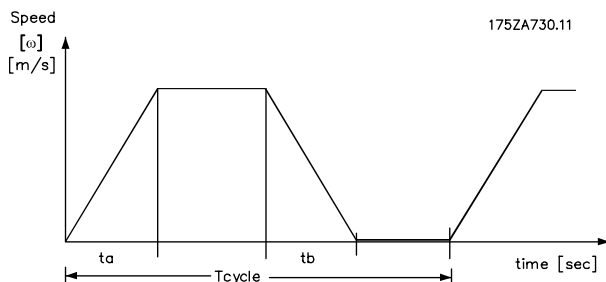

The maximum permissible load on the brake resistor is stated as a peak power at a given ED. The following



NB!:

If a short circuit in the brake transistor occurs, power dissipation in the brake resistor can only be prevented by using a mains switch or contactor to disconnect the mains for the frequency converter. (The contactor can be controlled by the frequency converter).

■ Automatic Motor Adaptation, AMA

Automatic motor adaptation is a test algorithm that measures the electrical motor parameters at a motor standstill. This means that AMA itself does not supply any torque.

AMA is useful when commissioning systems, where the user wants to optimise the adjustment of the frequency converter to the motor applied. This feature is used in particular where the factory setting does not adequately cover the motor in question.

There are five motor parameters (150-154) that are of primary significance in automatic motor adaptation: the stator resistance, R_s , rotor resistance, R_r , stator leakage reactance, X_1 , rotor leakage reactance, X_2 , main reactance X_h . Parameter 107 allows a choice of automatic motor adaptation, with determination of R_s , X_h , X_1 , X_2 , R_r or reduced automatic motor adaptation with determination of only R_s .

The duration of a total automatic motor adaptation varies from a few minutes on small motors to more than 10 minutes on large motors.

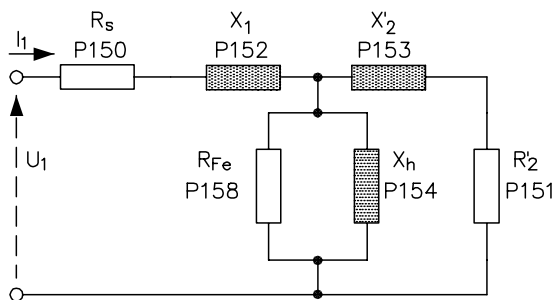

175ZA754.10

Limitations and preconditions:

- For AMA to be able to determine the motor parameters optimally, the correct nameplate data for the motor connected to the frequency converter must be entered in parameters 102 to 106.
- For the best adjustment of the frequency converter, it is recommended to carry out AMA on a cold motor. Repeated AMA runs may lead to a heating of the motor that will result in an increase of the resistance, R_s and R_r .
- AMA can only be carried out if the rated motor current is minimum 35% of the rated output current of the frequency converter. AMA can be carried out up to one oversize motor.
- If a LC filter is inserted between the frequency converter and the motor, a reduced test is preferred. If an overall setting is required, remove the LC filter while running a total AMA. After completion of the AMA reinsert the LC filter.
- Long motor cables can have an effect on the result of the AMA function.

How to perform an AMA

1. Press the [STOP/RESET] key
2. Set motor nameplate data in parameters 102-106
3. Select whether a total [ENABLE COMPLETE AMA] or an [ENABLE REDUCED AMA] is required in parameter 107
4. Connect terminal 12 (24 VDC) to terminal 37 on the control card
5. Connect terminal 12 (24 VDC) to terminal 27 on the control card
6. Connect terminal 12 (24 VDC) to terminal 18 on the control card
7. Press the [START] key to start the automatic motor adaptation.

Now the automatic motor adaptation goes through four tests (for reduced AMA only the first two tests). The process of the test can be followed in the display as dots after the text **WORKING** in parameter 107.



NB!:

AMA can only be carried out successfully if there are no alarms during tuning.

Discontinue AMA

If the automatic motor adaptation is to be discontinued, press the [STOP/RESET] key or disconnect terminal 18 from terminal 12.

The automatic motor adaptation ends up with one of the following messages after the test:

[AMA FINISHED OK]

The AMA was carried out successfully (parameter 107).

or

Warnings and alarm messages

ALARM 22

Auto-optimisation not OK

[AUTO MOTOR ADAPT FAIL]

A fault has been found during automatic motor adaptation. Press the [STOP/RESET] key or disconnect terminal 18 from terminal 12. Check the possible cause to the fault related to the alarm message given. The figure after the text is the error code, which can be seen in the fault log in parameter 615. Automatic motor adaptation has not updated the parameters. You may choose to run a reduced automatic motor adaptation.

CHECK P.103,105 [0]

[AUTO MOT ADAPT FAIL] Parameter 102, 103 or 105 has a wrong setting. Correct the setting and start AMA all over.

LOW P.105 [1]

The motor is too small for AMA to be carried out. If AMA is to be enabled, the rated motor current (parameter 105) must be higher than 35% of the rated output current of the frequency converter.

ASYMMETRICAL IMPEDANCE [2]

AMA has detected an asymmetrical impedance in the motor connected to the system. The motor could be defective.

MOTOR TOO BIG [3]

The motor connected to the system is too big for AMA to be carried out. The setting in parameter 102 does not match the motor used.

MOTOR TOO SMALL [4]

The motor connected to the system is too small for AMA to be carried out. The setting in parameter 102 does not match the motor used.

TIME OUT [5]

AMA fails because of noisy measuring signals. Try to start AMA all over a number of times, until AMA is carried out. Please note that repeated AMA runs may heat the motor to a level where the resistance R_s and R_r are increased. In most cases, however, this is not critical.

INTERRUPTED BY USER [6]

AMA has been interrupted by the user.

INTERNAL FAULT [7]

An internal fault has occurred in the frequency converter. Contact your Danfoss supplier.

LIMIT VALUE FAULT [8]

The parameter values found for the motor are outside the acceptable range within which the frequency converter is able to work.

MOTOR ROTATES [9]

The motor is probably rotating. Make sure that the load is not able to make the motor shaft rotate. Then start the AMA procedure again.

OVER CURRENT [10]

The inverter peak current limit has been exceeded. Check the motor size match the frequency converter size.

OVER VOLTAGE (DC-LINK OVER-VOLTAGE) [11]

The intermediate circuit voltage (DC) exceed the inverter over voltage limit.

UNDER VOLTAGE (DC-LINK UNDER-VOLTAGE) [12]

The intermediate circuit voltage (DC) has exceeded the inverter under-voltage limit.

WARNING 39 - 42

A fault have been encountered during automatic motor adaptation. Check the possible fault causes in accordance with the warning message. Press the [CHANGE DATA key and select "CONTINUE" if AMA is to continue despite the warning or press the [STOP/RESET] key or disconnect terminal 18 from terminal 12 to discontinue AMA.

WARNING: 39**CHECK P.104,106**

The setting of parameter 102, 104 or 106 is probably wrong. Check the setting and choose 'Continue' or 'Stop'.

WARNING: 40**CHECK P.103,105**

The setting of parameter 102, 103 or 105 is probably wrong. Check the setting and choose 'Continue' or 'Stop'.

WARNING: 41**MOTOR TOO BIG**

The motor used is probably too big for AMA to be carried out. The setting in parameter 102 may not match the motor. Check the motor and choose 'Continue' or 'Stop'.

WARNING: 42**MOTOR TOO SMALL**

The motor used is probably too small for AMA to be carried out. The setting in parameter 102 may not match the motor. Check the motor and choose 'Continue' or 'Stop'.

■ Flying start

Flying start function makes it possible to "catch" a motor that is spinning freely and for the frequency converter to take control of the motor speed. This function can be enabled or disabled via parameter 445.

If *flying start* is selected, there will be three situations in which the function is activated:

1. After a coast has been given via terminal 27.
2. After power-up.
3. If the frequency converter is in a trip state and a reset signal has been given.

1. *Flying start* is active (parameter 445 [1]).

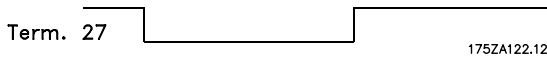
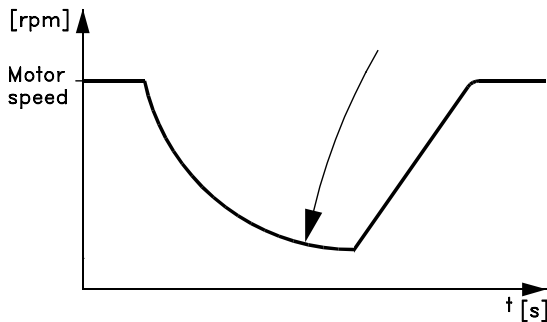

2. *Flying start* is active (parameter 445 [1]).

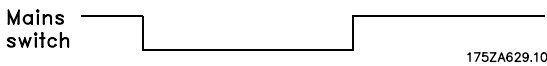
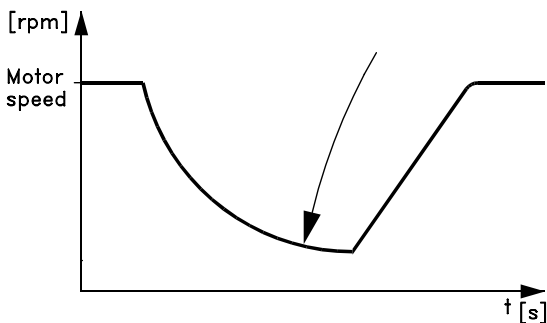

The search sequence for the spinning motor depends on *Rotation, speed/direction* (parameter 200). If only *clockwise* is selected, the frequency converter will start looking from *Maximum speed* (parameter 202) down to 0 rpm. If the frequency converter does not find the spinning motor during the search sequence, it will carry out a DC braking so as to try to bring the speed of the spinning motor down to 0 rpm. This requires that the DC brake is active via parameter 125 and parameter 126. If *Both directions* is selected, the frequency converter will first detect in which direction the motor rotates and then search for the speed. If the motor is not detected, the system assumes

that the motor is at a standstill or is rotating at a low speed, and the frequency converter will start the motor in the normal way after searching.

3. The frequency converter trips and *Flying start* is active.

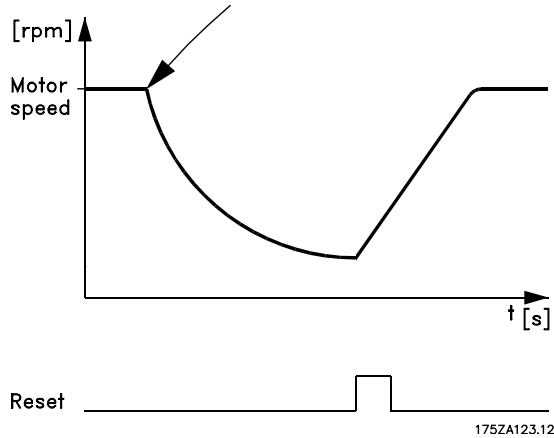

Reference Handling

■ Normal/high overload torque control

This function enables the frequency converter to perform a constant 100% torque, using an oversize motor. The choice between a normal or a high overload torque characteristic is made in parameter 101.

If a *high torque characteristic* is chosen, a rated motor with the frequency converter obtains up to 160% torque for 1 min. If a *normal torque characteristic* is chosen, an oversize motor allows up to 110% torque performance for up to 1 min.

The advantage of choosing a normal torque characteristic for an oversize motor is that the frequency converter will be able constantly to yield 100% torque, without derating as a result of a bigger motor.



NB!:

This function cannot be chosen for VLT 5001-5006, 200-240 Volts, and VLT 5001-5011, 380-500 Volts.

■ Operation and Display
■ Introduction

The parameter group 001 - 099 provides the adjustment and settings for the operation site and for the operation and settings of the LCP (Local Control Panel) display and storing unit.

PNU #	Parameter description	Factory setting	Range	Changes during operation	4-Setup	Conversion index	Data type
001	Language	English		No	No	0	5
002	Local/remote control	Remote control		Yes	Yes	0	5
003	Local reference	000.000		Yes	Yes	-3	4
004	Active setup	Setup 1		Yes	No	0	5
005	Programming setup	Active setup		Yes	No	0	5
006	Copying of setups	No copying		No	No	0	5
007	LCP copy	No copying		No	No	0	5
008	Display scaling speed	1	0.01 - 100.00	Yes	Yes	-2	6
009	Display line 2	Speed [rpm]		Yes	Yes	0	5
010	Display line 1.1	Reference [%]		Yes	Yes	0	5
011	Display line 1.2	Motor current [A]		Yes	Yes	0	5
012	Display line 1.3	Power [kW]		Yes	Yes	0	5
013	Local operation mode	LCP control		Yes	Yes	0	5
014	Local stop	Enable		Yes	Yes	0	5
015	Local jog	Not possible		Yes	Yes	0	5
016	Local reversing	Not possible		Yes	Yes	0	5
017	Local reset of trip	Possible		Yes	Yes	0	5
018	Lock for data change	Not locked		Yes	Yes	0	5
019	Operating state at power-up, local control	Forced stop, use saved ref.		Yes	Yes	0	5
024	Userdefined Quick Menu	Not active		Yes	No	0	5
025	Quick Menu Setup	000	0-999	Yes	No	0	6

Changes during operation:

"Yes" means that the parameter can be changed, while the frequency converter is in operation. "No" means that the frequency converter must be stopped before a change can be made.

4-Setup:

"Yes" means that the parameter can be programmed individually in each of the four setups, i.e. the same parameter can have four different data values. "No" means that the data value will be the same in all four setups.

Conversion index:

This number refers to a conversion figure to be used when writing or reading by means of a frequency converter.

Conversion index	Conversion factor
74	0.1
2	100
1	10
0	1
-1	0.1
-2	0.01
-3	0.001
-4	0.0001

Data type:

Data type shows the type and length of the telegram.

Data type	Description
3	Integer 16
4	Integer 32
5	Unsigned 8
6	Unsigned 16
7	Unsigned 32
9	Text string

★ = factory setting. () = display text [] = value for use in communication via serial communication port

001 Language

(LANGUAGE)

Value:

★English (ENGLISH)	[0]
German (DEUTSCH)	[1]
French (FRANCAIS)	[2]
Danish (DANSK)	[3]
Spanish (ESPAÑOL)	[4]
Italian (ITALIANO)	[5]

Function:

This parameter defines the language to be used on the display.

002 Local/remote control

(OPERATION SITE)

Value:

★Remote control (REMOTE)	[0]
Local control (LOCAL)	[1]

Function:

There is a choice of two methods of controlling the frequency converter.

Description of choice:

If *Remote control* [0] is selected, the frequency converter can be controlled via:

1. The control terminals or the serial communication port.
2. The [START] key. However, this cannot overrule Stop commands (also start-disable) entered via the digital inputs or the serial communication port.
3. The [STOP], [JOG] and [RESET] keys, provided that these are active (see parameter 014, 015 and 017).

If *Local control* [1] is selected, the frequency converter can be controlled via:

1. The [START] key. However, this cannot override Stop commands on the digital terminals (if [4] has been selected in parameter 013).
2. The [STOP], [JOG] and [RESET] keys, provided that these are active (see parameter 014, 015 and 017).
3. The [FWD/REV] key, provided that this has been activated in parameter 016 and that in parameter 013 a choice of [3] has been made.
4. Via parameter 003 the local reference can be controlled by means of the "Arrow up" and "Arrow down" keys.
5. An external control command that can be connected to terminal 16, 17, 19, 27, 29, 32 or 33. However, [4] must be selected in parameter 013.



NBI:

Please be aware that terminal 37 (hardware coast) is always active.

See also section *Shift between local and remote control*.

003 Local reference

(LOCAL REFERENCE)

Value:

Parameter 203 = [0] set for:

Ref_{MIN} - Ref_{MAX} ★ 000.000

Parameter 203 = [1] set for:

-Ref_{MAX} - + Ref_{MAX} ★ 000.000

Function:

This parameter allows manual setting of the desired reference value.

The unit follows the configuration selected in parameter 100, where Speed is measured in RPM, and torque in NM.

Description of choice:

Local [1] must be selected in parameter 002 for this parameter to be used.

The set value is saved in the case of a voltage drop-out, see parameter 019.

In this parameter Data Change Mode is not exited automatically (after time out).

Local reference cannot be set via the serial communication port.



Warning: Since the value set is stored after the power has been cut, the motor may start without warning when the power is reapplied; if parameter 019 is changed to *Auto restart, use saved ref.* [0].

004 Active Setup

(ACTIVE SETUP)

Value:

Factory Setup (FACTORY SETUP)	[0]
★Setup 1 (SETUP 1)	[1]
Setup 2 (SETUP 2)	[2]
Setup 3 (SETUP 3)	[3]
Setup 4 (SETUP 4)	[4]
MultiSetup (MULTI SETUP)	[5]

★ = factory setting. () = display text [] = value for use in communication via serial communication port

Function:

This parameter defines the Setup number to control the functions of the frequency converter. All parameters can be programmed in four individual parameter Setups, Setup 1 - Setup 4. In addition, there is a Factory Setup, which cannot be modified.

Description of choice:

Factory Setup [0] contains the data set at the works. Can be used as a data source if the other Setups are to be returned to a known state. Parameter 005 and 006 allow copying from one Setup to one or all the other Setups. *Setups* 1-4 [1]-[4] are four individual Setups that can be selected individually. *Multi-Setup* [5] is used by remote-switching between Setups. Terminals 16/17/29/32/33 as well as the serial communication port can be used for switching between Setups.



A stop signal must be applied when switching between open loop and closed loop functions.

005 Programming Setup

(EDIT SETUP)

Value:

Factory Setup (FACTORY SETUP)	[0]
Setup 1 (SETUP 1)	[1]
Setup 2 (SETUP 2)	[2]
Setup 3 (SETUP 3)	[3]
Setup 4 (SETUP 4)	[4]
★Active Setup (ACTIVE SETUP)	[5]

Function:

The choice is of the Setup in which programming (change of data) is to occur during operation (applies both via the control panel and via the serial communication port). The 4 Setups can be programmed independently of the Setup selected as the active Setup (selected in parameter 004).

Description of choice:

The *Factory Setup* [0] contains the data set at the works and can be used as a data source if the other Setups are to be returned to a known state. *Setups* 1-4 [1]-[4] are individual Setups which can be used as required. They can be programmed freely, regardless of the Setup selected as the active Setup and thus controlling the functions of the frequency converter.



NB!:

If a general change of data or a copying to the active Setup is effected, this immediately affects the functioning of the unit.

006 Copying of Setups

(SETUP COPY)

Value:

★No copying (NO COPY)	[0]
Copy to Setup 1 from # (COPY TO SETUP 1)	[1]
Copy to Setup 2 from # (COPY TO SETUP 2)	[2]
Copy to Setup 3 from # (COPY TO SETUP 3)	[3]
Copy to Setup 4 from # (COPY TO SETUP 4)	[4]
Copy to Setup all from # (COPY TO ALL)	[5]

= the Setup selected in parameter 005

Function:

A copy is made from the Setup selected in parameter 005 to one of the other Setups or to all the other Setups simultaneously. The setup copying function does not copy parameter 001, 004, 005, 500 and 501.

Copying is only possible in Stop Mode (motor stopped on a Stop command).

Description of choice:

The copying starts when the desired copying function has been entered and confirmed by pressing the [OK] key. The display indicates when copying is in progress.



NB!:

Setup Copy must only be carried out in the Stop mode.

007 LCP copy

(LCP COPY)

Value:

★No copying (NO COPY)	[0]
Upload all parameters (UPLOAD ALL PARAM)	[1]
Download all parameters (DOWNLOAD ALL)	[2]
Download power-independent par. (DOWNLOAD SIZE INDEP.)	[3]

Function:

Parameter 007 is used if it is desired to use the integrated copying function of the control panel. The control panel is detachable. You can therefore easily copy parameter value(s) from one to another.

Description of choice:

Select *Upload all parameters* [1] if all parameter values are to be transmitted to the control panel.
 Select *Download all parameters* [2] if all transmitted parameter values are to be copied to the frequency converter on which the control panel has been mounted.
 Select *Download power-independent par.* [3] if only the power-independent parameters are to be downloaded. This is used if downloading to a frequency converter that has a different rated power than the one from where the parameter Setup originates.
 Please note that the power-dependent parameter 102-106 must be programmed after copying.



NB!:

Uploading/Downloading can only be carried out in the Stop mode.

008 Display scaling speed

(SPEED SCALE)

Value:

0.01 - 100.00 ★ 1

Function:

This parameter chooses the factor to be multiplied by the motor speed, for presentation in the display, when parameter 009-012 have been set for Speed x Scaling [5].

Description of choice:

Set the desired scaling factor.

009 Display line 2

(DISPLAY LINE 2)

Value:

Reference [%] (REFERENCE [%])	[1]
Reference [unit] (REFERENCE [UNIT])	[2]
Frequency [Hz] (FREQUENCY [HZ])	[4]
★Speed [RPM] (SPEED [RPM])	[5]
Motor current [A] (MOTOR CURRENT [A])	[6]
Torque [%] (TORQUE [%])	[7]
Power [kW] (POWER [KW])	[8]
Power [HP] (POWER [HP] [US])	[9]
Output energy [kWh] (OUTPUT ENERGY [KWH])	[10]
Motor voltage [V] (MOTOR VOLTAGE [V])	[11]
DC link voltage [V] (DC LINK VOLTAGE [V])	[12]
Thermal load, motor [%] (MOTOR THERMAL [%])	[13]
Thermal load, VLT [%] (VLT THERMAL [%])	[14]
Hours run [Hours] (RUNNING HOURS)	[15]

Digital input [Binary code] (DIGITAL INPUT [BIN])	[16]
Analogue input 53 [V] (ANALOG INPUT 53 [V])	[17]
Analogue input 54 [V] (ANALOG INPUT 54 [V])	[18]
Analogue input 60 [mA] (ANALOG INPUT 60 [MA])	[19]
Pulse reference [Hz] (PULSE REF. [HZ])	[20]
External reference [%] (EXTERNAL REF [%])	[21]
Status word [Hex] (STATUS WORD [HEX])	[22]
Brake effect/2 min. [kW] (BRAKE ENERGY/2 MIN)	[23]
Brake effect/sec. [kW] (BRAKE ENERGY/S)	[24]
Heat sink temp. [°C] (HEATSINK TEMP [°C])	[25]
Alarm word [Hex] (ALARM WORD [HEX])	[26]
Control word [Hex] (CONTROL WORD [HEX])	[27]
Warning word 1 [Hex] (EXT. STAT. WORD [HEX])	[28]
Warning word 2 [Hex] (WARNING WORD 2 [HEX])	[29]
Digital Output [Bin] (DIGITAL OUTPUT [BIN])	[30]
Communication option card warning (COMM OPT WARN [HEX])	[31]
KTY sensor [°C] (KTY SENSOR TEMP)	[32]

Function:

This parameter allows a choice of the data value to be displayed in line 2 of the display. Parameter 010-012 enable the use of three additional data values to be displayed in line 1.

Description of choice:

Reference [%] corresponds to the total reference (sum of digital/analogue/preset/bus/freeze ref./catch-up and slow-down).

Reference [unit] gives the status value of terminals 17/29/53/54/60 using the unit stated on the basis of configuration in parameter 100 (rpm).

Frequency [Hz] gives the motor frequency, i.e. the output frequency from the frequency converter.

Speed [RPM] Display the speed in RPM (Rounds per Minute) i.e. the motor shaft speed in closed loop.

Motor current [A] states the phase current of the motor measured as effective value.

Torque [%] gives the current motor load in relation to the rated motor torque.

Power [kW] states the actual power consumed by the motor in kW.

Power [HP] states the actual power consumed by the motor in HP.

Output energy [kWh] states the energy consumed by the motor since the latest reset was made in parameter 618.

★ = factory setting. () = display text [] = value for use in communication via serial communication port

Motor voltage [V] states the voltage supplied to the motor.

DC link voltage [V] states the intermediate circuit voltage in the frequency converter.

Thermal load, motor [%] states the calculated/estimated thermal load on the motor. 100% is the cut-out limit.

Thermal load, VLT [%] states the calculated/estimated thermal load on the frequency converter. 100% is the cut-out limit.

Hours run [Hours] states the number of hours that the motor has run since the latest reset in parameter 619.

Digital input [Binary code] states the signal states from the 8 digital terminals (16, 17, 18, 19, 27, 29, 32 and 33) Input 16 corresponds to the bit at the far left. '0' = no signal, '1' = connected signal.

Analogue input 53 [V] states the signal value on terminal 53.

Analogue input 54 [V] states the signal value on terminal 54.

Analogue input 60 [V] states the signal value on terminal 60.

Pulse reference [Hz] states the possible frequency in Hz connected to the terminals 17 or 29.

External reference [%] gives the sum of the external reference as a percentage (the sum of analogue/pulse/bus).

Status word [Hex] gives the status word sent via the serial communication port in Hex code from the frequency converter.

Brake power/2 min [KW] states the brake power transferred to an external brake resistor. The mean power is calculated continuously for the latest 120 seconds.

The resistor value must be entered in parameter 401.

Brake power/sec [kW] states the present brake power transferred to an external brake resistor. Stated as an instantaneous value.

The resistor value must be entered in parameter 401.

Heat sink temp [°C] states the present heat sink temperature of the frequency converter. The cut-out limit is $90 \pm 5^\circ\text{C}$; cutting back in occurs at $60 \pm 5^\circ\text{C}$.

Alarm word [Hex] indicates one or several alarms in a Hex code.

Control word [Hex] indicates the control word for the frequency converter. See *Serial communication* in the Design Guide for VLT 5000 Process.

Warning word [Hex] indicates one or more warnings in a Hex code.

Ext. Status Word [Hex] indicates one or more status states in a Hex code.

Digital Output [Bin] (26, 46)

Communication option card warning [Hex] gives a warning word if there is a fault on the

communication bus. Is only active if communication options have been installed. Without communication options, 0 Hex is displayed.

KTY sensor [°C] states the present temperature of the windings of the motor, when the KTY sensor is connected to analogue input (terminal 54). When the KTY sensor is not connected, it shows 20°C .

010 Display line 1.1 (DISPLAY LINE 1.1)

011 Display line 1.2 (DISPLAY LINE 1.2)

012 Display line 1.3 (DISPLAY LINE 1.3)

Value:

As for parameter 009

Function:

parameter 010 - 012 is a choice of three different data values to be shown on the display, line 1 position 1, line 1 position 2 and line 1 position 3, respectively. For display read-outs, press the [DISPLAY/STATUS] button. See the sections *Control Panel* and *Display Mode*.

Description of choice:

There is a choice of 32 different data values, see parameter 009.

Factory setting for each parameter:

Parameter 010 [1]	Reference [%]
Parameter 011 [6]	Motor current [A]
Parameter 012 [8]	Power [kW]

013 Local operation mode

(LOCAL OPER. MODE)

Value:

Local not active (DISABLE)	[0]
★LCP control (LCP CONTROL)	[3]
LCP digital control (LCP+DIG CONTROL)	[4]

Function:

This is where the desired function is to be selected if Local control has been chosen in parameter 002. See the description of parameter 100.

Description of choice:

If *Local not active* [0] is selected, a possible setting of *Local reference via parameter 003* is blocked. It is only possible to change to *Local not active* [0] from one of the other setting options in parameter

★ = factory setting. () = display text [] = value for use in communication via serial communication port

013, when the frequency converter has been set to *Remote control* [0] in parameter 002.

LCP control [3] is selected if the reference is to be set via parameter 003.

LCP digital control [4] functions as *LCP control* [3], although, when parameter 002 has been set to *Local operation* [1], the motor may be controlled via the digital inputs in accordance with the list in section *Shift between local and remote control*.

Shift from Remote to Local

The present reference will be maintained.

Shift from Local to Remote

The reference will be replaced by the active reference signal from the remote control.

014 Local stop

(LOCAL STOP)

Value:

Disable (DISABLE)	[0]
★Enable (ENABLE)	[1]

Function:

This parameter disables/enables the local stop function from the LCP.

Description of choice:

If *Disable* [0] is selected, the [STOP] key will be inactive.



NB!:

If *Enable* is selected, the [STOP] key overrules all Start commands.

015 Local jog (LOCAL JOGGING)

Value:

★Not possible (DISABLE)	[0]
Possible (ENABLE)	[1]

Function:

This parameter enables/disables the local jog function on the LCP.

The key is used when parameter 002 has been set for *Remote control* [0] or *Local* [1].

Description of choice:

If *Disable* [0] is selected, the [JOG] key will be inactive.

016 Local reversing

(LOCAL REVERSING)

Value:

★Not possible (DISABLE)	[0]
Possible (ENABLE)	[1]

Function:

This parameter enables/disables the reversing function on the LCP.

This key can only be used if parameter 002 has been set to *Local operation* [1] and parameter 013 to *LCP control* [3].

Description of choice:

If *Disable* [0] is selected, the [FWD/REV] key will be inactive.
See parameter 200.

017 Local reset of trip (LOCAL RESET)

Value:

Not possible (DISABLE)	[0]
★Possible (ENABLE)	[1]

Function:

In this parameter, the reset function can be selected/removed from the keyboard.

This key can be used when parameter 002 has been set for *Remote control* [0] or *Local control* [1].

Description of choice:

If *Disable* [0] is selected in this parameter, the [RESET] key will be inactive.



NB!:

Only select *Disable* [0] if an external reset signal has been connected via the digital inputs.

018 Lock for data change

(DATA CHANGE LOCK)

Value:

★Not locked (NOT LOCKED)	[0]
Locked (LOCKED)	[1]

Function:

In this parameter, the software can "lock" the control, which means that data changes cannot be made via LCP (however, this is still possible via the serial communication port).

Description of choice:

If *Locked* [1] is selected, data changes cannot be made.

019 Operating state at Power up, local control (POWER UP ACTION)

Value:

Auto restart, use saved ref. (AUTO RESTART)	[0]
★ Forced stop, use saved ref. (LOCAL=STOP)	[1]
Forced stop, set ref. to 0 (LOCAL=STOP, REF=0)	[2]

Function:

Setting of the operating mode when the mains voltage is reconnected.
This function can only be active in connection with *Local control* [1] in parameter 002.

Description of choice:

Auto restart, use saved ref. [0] is selected if the unit is to start up with the same local reference (set in parameter 003) and the same start/stop conditions (given via the [START/STOP] keys) that the frequency converter had before it was switched off.

Forced stop, use saved ref. [1] is used if the unit is to remain stopped when the mains voltage is connected, until the [START] key is pressed.

After the start command, the local reference used is set in parameter 003.

Forced stop, set ref. to 0 [2] is selected if the unit is to remain stopped when the mains voltage is connected. Local reference (parameter 003) is reset.



NB!:

In remote controlled operation (parameter 002), the start/stop condition at power up will depend on the external control signals.
If *Pulse start* [2] is selected in parameter 302, the motor will remain stopped at power-up.

024 Userdefined Quick Menu (USER QUICKMENU)

Value:

★ Not active (DISABLE)	[0]
Active (ENABLE)	[1]

Function:

In this parameter you can select the standard setup of the Quick menu key on the control panel and the LCP 2 control panel.

Using this function, in parameter 025 *Quick Menu setup* the user can select up to 20 parameters for the Quick Menu key.

Description of choice:

If *not active* [0] is selected, the standard setup of the Quick Menu key is active.

If *Active* [1] is selected, the user-defined Quick Menu is active.

025 Quick Menu setup

(QUICK MENU SETUP)

Value:

[Index 1 - 20] Value: 0 - 999 ★ 000

Function:

In this parameter you define which parameters are required in the Quick Menu when parameter 024 *User-defined Quick Menu* is set to *Active* [1].
Up to 20 parameters can be selected for the user-defined Quick Menu.

Description of choice:

The Quick Menu is set up as follows:

1. Select parameter 025 *Quick Menu setup* and press [CHANGE DATA].
2. Index 1 indicates the first parameter in Quick Menu. You can scroll between the index numbers using the [+ / -] keys. Select Index 1.
3. Using [< >] you can scroll between the three figures. Press the [<] key once and the last number in the parameter number can be selected using the [+ / -] keys. Set Index 1 to 100 for parameter 100 *Configuration*.
4. Press [OK] when Index 1 has been set to 100.
5. Repeat steps 2 - 4 until all parameters required have been set to the Quick Menu key.
6. Press [OK] to complete the Quick Menu setup. If parameter 100 *Configuration* is selected at Index 1, Quick Menu will start with this parameter every time Quick Menu is activated.

Please note that parameter 024 *User-defined Quick Menu* and parameter 025 *Quick Menu setup* are reset to the factory setting during initialisation.

■ Load and motor
■ Introduction

The parameter group 100 - 199 provides the adjustments and settings for load and motor connected to the frequency converter.

PNU #	Parameter description	Factory setting	Range	Changes during operation	4-Setup	Conversion index	Data type
100	Configuration	Speed control, closed loop		No	Yes	0	5
101	Torque characteristics	High - constant torque		No	Yes	0	5
102	Motor power	Depends on the unit	0.18-500 kW	No	Yes	1	6
103	Motor voltage	Depends on the unit	200 - 500 V	No	Yes	0	6
104	Motor frequency	50 Hz		No	Yes	0	6
105	Motor current	Depends on the unit	0.01- $I_{VLT,MAX}$	No	Yes	-2	7
106	Rated motor speed	Depends on the unit	100-60000 rpm	No	Yes	0	6
107	Automatic motor adaptation, AMA	Adaptation off		No	No	0	5
115	Slip Compensating	100%	-400% - +400%	Yes	Yes	0	3
116	Slip compensation time constant	0.50 sec.	0.05-5.00 sec.	Yes	Yes	-2	6
119	High starting torque	0.0 sec.	0.0 - 0.5 sec.	Yes	Yes	-1	5
120	Start delay	0.0 sec.	0.0 - 10.0 sec.	Yes	Yes	-1	5
121	Start function	Coasting in start delay time		Yes	Yes	0	5
122	Function at stop	Coasting		Yes	Yes	0	5
123	Min. speed for activating function at stop	0 rpm	0 - 600 rpm	Yes	Yes	-1	5
124	DC holding current	50 %	0 - 100 %	Yes	Yes	0	6
125	DC braking current	50 %	0 - 160 %	Yes	Yes	0	6
126	DC braking time	10.0 sec.	0.0 - 60.0 sec.	Yes	Yes	-1	6
127	DC brake cut-in speed	Off	0.0-par. 202	Yes	Yes	-1	6
128	Motor thermal protection	No protection		Yes	Yes	0	5
129	External motor fan	No		Yes	Yes	0	5
130	Start speed	0.0 rpm	0.0 - 600 rpm	Yes	Yes	-1	5
131	Initial current	0.0 Amp	0.0-par. 105	Yes	Yes	-1	6
150	Stator resistance	Depends on unit	Ohm	No	Yes	-4	7
151	Rotor resistance	Depends on unit	Ohm	No	Yes	-4	7
152	Stator leakage reactance	Depends on unit	Ohm	No	Yes	-3	7
153	Rotor leakage reactance	Depends on unit	Ohm	No	Yes	-3	7
154	Main reactance	Depends on unit	Ohm	No	Yes	-3	7
156	Pole number	4-pole motor	2-100	No	Yes	0	5
158	Ironloss resistance	10000Ω	1 - 10000Ω	No	Yes	0	6
161	Minimum Inertia	Depends on unit	Kgm ²	No	Yes	-4	7
162	Maximum Inertia	Depends on unit	Kgm ²	No	Yes	-4	7
163	Functional stop delay	0	0 - 5 sec	Yes	Yes	-1	7
164	Mech. brake release delay	0.5 sec	0.01 - 2.00 sec	Yes	Yes	-2	U16
165	Mech. brake initial torque	20%	+/- P221	Yes	Yes	-1	S16
166	Mech. brake initial direction	[0] Clockwise	[0] Clockwise [1] Ref. dir.	Yes	Yes	0	U8
167	Proportional gain boost, during brake release	100%	0-400%	Yes	Yes	0	S16

★ = factory setting. () = display text [] = value for use in communication via serial communication port

See also *Operation and Display* for further information regarding Changes during operation, 4-Setup and Conversion index.

100 Configuration (CONFIG. MODE)

Value:	
Speed control, open loop (SPEED OPEN LOOP)	[0]
★Speed control, closed loop (SPEED CLOSED LOOP)	[1]
Torque control, speed feedback (TORQUE CONTROL SPEED)	[5]

Function:

This parameter is used for selecting the configuration to which the frequency converter is to be adapted. This makes adaptation to a given application simple, because the parameters that are not used in the given configuration are covered up (not active). By changing between the different application configurations, bumpless transfer is ensured.

Description of choice:

If *Speed control, open loop* [0] is selected a normal speed control (without feedback signal) is obtained, but with automatic slip compensation, ensuring a nearly constant speed at varying loads. Compensations are active, but may be disabled as required in the 'Load and motor' parameter group.

If *Speed control, closed loop* [1] is selected, a full holding torque is obtained at 0 rpm, in addition to increased speed accuracy. A feedback signal must be provided and the speed PID regulator must be set.

If *Torque control, speed feedback* [5] is selected, an encoder speed feedback signal must be connected to the encoder input.



Switching between open loop and closed loop can only happen when a stop command has been applied.

101 Torque characteristics (TORQUE CHARACT)

Value:	
★High-constant torque (H-CONSTANT TORQUE)	[1]
Normal-constant torque (N-CONSTANT TORQUE)	[11]

Function:

Selecting of torque characteristics.

Description of choice:

By VLT 5000 Flux it is possible to select High-Constant Torque or Normal-constant torque .

102 Motor power (MOTOR POWER)

Value:	
0.18 kW (0.18 KW)	[18]
0.25 kW (0.25 KW)	[25]
0.37 kW (0.37 KW)	[37]
0.55 kW (0.55 KW)	[55]
0.75 kW (0.75 KW)	[75]
1.1 kW (1.10 KW)	[110]
1.5 kW (1.50 KW)	[150]
2.2 kW (2.20 KW)	[220]
3 kW (3.00 KW)	[300]
4 kW (4.00 KW)	[400]
5.5 kW (5.50 KW)	[550]
7.5 kW (7.50 KW)	[750]
11 kW (11.00 KW)	[1100]
15 kW (15.00 KW)	[1500]
18.5 kW (18.50 KW)	[1850]
22 kW (22.00 KW)	[2200]
30 kW (30.00 KW)	[3000]
37 kW (37.00 KW)	[3700]
45 kW (45.00 KW)	[4500]
55 kW (55.00 KW)	[5500]
75 kW (75.00 KW)	[7500]
90 kW (90.00 KW)	[9000]
110 kW (110.00 KW)	[11000]
132 kW (132.00 KW)	[13200]
160 kW (160.00 KW)	[16000]
200 kW (200.00 KW)	[20000]
250 kW (250.00 KW)	[25000]
280 kW (280.00 KW)	[28000]
315 kW (315.00 KW)	[31500]
355 kW (355.00 KW)	[35500]
400 kW (400.00 KW)	[40000]
450 kW (450.00 KW)	[45000]
500 kW (500.00 KW)	[50000]

Depends on the unit

Function:

Selects the kW value that corresponds to the rated power of the motor.

A rated kW value has been selected as the factory setting that corresponds to the unit size.

Description of choice:

Select a value that equals the nameplate data on the motor. There are 4 possible undersizes or 1 oversize in comparison with the factory setting.

Also, alternatively it is possible to set the value for motor power as an infinitely variable value.

The set value automatically changes the values of the motor parameters in parameter 150-154, 157 and 161.

★ = factory setting. () = display text [] = value for use in communication via serial communication port

103 Motor voltage

(MOTOR VOLTAGE)

Value:

200 V	[200]
208 V	[208]
220 V	[220]
230 V	[230]
240 V	[240]
380 V	[380]
400 V	[400]
415 V	[415]
440 V	[440]
460 V	[460]
480 V	[480]
500 V	[500]

Depends on the unit.

Note: 500 V motor voltages must be manually programmed - pre-sets are not available.

Function:

Select the motor voltage that equals the nameplate data on the motor.



NB!:

The motor will always see the peak voltage, corresponding to the connected supply voltage, in case of regenerative operation, the voltage can be higher.

Description of choice:

Select a value that equals the nameplate data on the motor, regardless of the mains voltage for the frequency converter. Furthermore, alternatively it is possible to set the value of the motor voltage infinitely variably. The value set automatically changes values for the motor parameters in parameter 150-154. For 87 Hz operation with 230/400 V motors, set the nameplate data for 230 V/50 Hz. Adapt parameter 202 *Output speed high limit* and parameter 205 *Maximum reference* to the 87 Hz application.



NB!:

If a delta connection is used, the rated motor speed for the delta connection must be selected.

104 Motor frequency

(MOTOR FREQUENCY)

Value:

★50 Hz (50 HZ)	[50]
60 Hz (60 HZ)	[60]

Max. motor frequency 300 Hz.

★ = factory setting. () = display text [] = value for use in communication via serial communication port

Function:

Selecting the rated motor frequency $f_{M,N}$ (nameplate data).

Description of choice:

Select a value that equals the nameplate data on the motor.

Alternatively it is also possible to set the value for motor frequency infinitely variably.

If a value different from 50 Hz or 60 Hz is selected, it is necessary to correct parameter 150-154.

For 87 Hz operation with 230/400 V motors, set the nameplate data for 230 V/50 Hz. Adapt parameter 202 *Output speed high limit* and Parameter 205 *Maximum reference* to the 87 Hz application.



NB!:

If a delta connection is used, the rated motor frequency for the delta connected must be selected.

105 Motor current (MOTOR CURRENT)

Value:

0.01 - $I_{VLT,MAX}$ [0.01 - XXX.X]

Depends on the unit.

Function:

The rated motor current $I_{M,N}$ forms part of the frequency converter calculations i.a. of torque and motor thermal protection.

Description of choice:

Select the nameplate value from the motor. Enter the value in Ampere.



NB!:

It is important to enter the correct value, since this forms part of the Flux vector control feature.

106 Rated motor speed

(MOTOR NOM. SPEED)

Value:

100 - 60000 rpm (RPM) [100 - 60000]

Depends on the motor type.

Function:

The selected value corresponds to the rated motor speed $n_{M,N}$, from the motor nameplate data.

Description of choice:

The rated motor speed $n_{M,N}$ is used i.a. for calculating the optimal slip compensation.



NB!:

It is important to enter the correct value, since this forms part of the Flux vector control feature. The max. value equals $f_{M,N}$ x 60. Set $f_{M,N}$ in parameter 104.



NB!:

There must not be any externally generating torque during automatic motor adaptation.



NB!:

If the setting in parameter 102-106 is changed, the parameters 150-154 will return to factory setting.

107 Automatic motor adaptation, AMA (AUTO MOTOR ADAPT)

Value:

- ★Adaptation off (OFF) [0]
- Adaptation on Complete, R_S , X_1 , X_2 , X_h , R_r
(ENABLE COMPLETE AMA) [1]
- Adaptation on Reduced, R_S
(ENABLE REDUCED AMA) [2]

Function:

If the AMA function is used, the frequency converter automatically sets the necessary control parameters (parameters 150-154) with the motor stationary. Automatic motor adaptation ensures optimum use of the motor.

For the best possible adaptation of the frequency converter, it is recommended to run AMA on a cold motor.

The AMA function is activated by pressing the [START] key after selecting [1] or [2].

See also section *Automatic motor adaptation*.

After a normal sequence, the display will read "AMA finished OK". Press the [STOP/RESET] key. The frequency converter is now ready for operation.

Description of choice:

Select *Enable complete AMA*, if the frequency converter is to be able to carry out automatic motor adaptation of the stator resistance R_S , the rotor resistance R_r , the stator leakage reactance x_1 , the rotor leakage reactance X_2 and the main reactance X_h .

Select *Optimisation on, Reduced AMA* [2] if a reduced test is to be carried out, in which only the stator resistance in the system is determined.



NB!:

It is important to set motor parameters 102-106 correctly, since these form part of the AMA algorithm. For optimum dynamic motor adaptation, an AMA must be carried out. Motor adaptation may take up to 10 minutes, depending on the power rating of the motor in question.

115 Slip compensation

(SLIP COMPENSAT.)

Value:

-400 - 400 % ★ 100 %

Function:

This function is only active together with *Speed Control Open Loop* (parameter 100) ensuring a nearly constant speed at varying loads. Compensations are active, but may be disabled as required in the 'Load and motor' parameter group. Slip compensation is calculated automatically, i.e. on the basis of the rated motor speed $n_{M,N}$. In parameter 115, slip compensation can be fine adjusted in parameter 115, which compensates for tolerances in the value of $n_{M,N}$.

Slip compensation is not active below the value stated in parameter 237.

Description of choice:

Enter a percentage value of the rated motor frequency (parameter 104).

Slip compensation is only active from 10 Hz in open loop.

116 Slip compensation time constant

(SLIP TIME CONST.)

Value:

0.05 - 5.00 sec. ★ 0.50 sec.

Function:

This function is active together with *Speed Control Open Loop* (parameter 100). This parameter determines the slip compensation reaction speed.

Description of choice:

A high value results in slow reaction. Opposite a low value will result in quick reaction. If low-frequency resonance problems are encountered, the time setting must be longer.

★ = factory setting. () = display text [] = value for use in communication via serial communication port

119 High starting torque
(HIGH START TORQ.)
Value:

 0.0 - 0.5 sec. ★ 0.0 sec.
Function:

This function is active together with *Speed Control Closed Loop* (parameter 100). In order to obtain a high starting torque, approx. $2 \times I_{VLT,N}$ for max. 0.5 sec. However, the current is limited by the protection limit of the frequency converter.

Description of choice:

Set the high starting torque time.

120 Start delay (START DELAY)
Value:

 0.0 - 10.0 sec. ★ 0.0 sec.
Function:

This parameter enables a delay of the starting time. The frequency converter begins with the start function selected in parameter 121.

Description of choice:

Set the start delay time until acceleration is to begin. When Mechanical Brake Release [6] has been chosen in Parameter 121, a minimum time is calculated based on motor data and the time set in Parameter 164.

121 Start function (START FUNCTION)
Value:

- DC hold in start delay time (DC HOLD/DELAY TIME) [0]
- DC brake in start delay time (DC BRAKE/DELAY TIME) [1]
- Coasting in start delay time (COAST/DELAY TIME) [2]
- Start speed/current clockwise. (CLOCKWISE OPERATION) [3]
- Start speed/current in reference direction (HORIZONTAL OPERATION) [4]
- ★Start speed clockwise (START SPEED CLOCKW) [5]
- Mechanical Brake Release (MECH BRAKE RELEASE) [6]

Function:

Selecting the start function during start delay when (parameter 120) is selected.

Description of choice:

Select *DC hold in the start delay time* [0] to energize the motor with a DC holding current (parameter 124) in the start delay time.

Select *DC brake in the start delay time* [1] to energize the motor with a DC braking current (parameter 125) during start delay time.

Select *Coasting in the start delay time* [2] and the motor will not be controlled by the frequency converter during the start delay time (inverter off).

Select *Start speed/current clockwise* [3] to connect the function described in parameter 130 and 131 in the start delay time.

Regardless of the value applied by the reference signal, the output speed will apply the setting of the start speed in parameter 130 and the output current will correspond to the setting of the start current in parameter 131. Select *Start speed/current in reference direction* [4] in order to obtain the function described in parameter 130 and 131 during the start delay time. The motor will always rotate in the reference direction. If the reference signal equals zero (0) parameter 130 *Start speed* will be ignored and the output speed will equal zero (0). The output current will correspond to the setting of the start current in parameter 131 *Start current*.

Select *Start/speed clockwise* [5] to have only the function described in parameter 130 *Start speed* in the start delay time. The start current will automatically be calculated.

Notice: This function only uses the start speed in the start delay time.

Regardless of the value set by the reference signal, the output speed will equal the setting of the start speed in parameter 130.

Mechanical Brake Release is typically used in Crane, Lift and other hoisting applications. Mechanical Brake Release can be used both in closed and open loop.

122 Function at stop
(FUNCTION AT STOP)
Value:

- ★Coasting (COAST) [0]
- DC hold (DC-HOLD) [1]
- Motor check (MOTOR CHECK) [2]
- Pre-magnetizing (PREMAGNETIZING) [3]

★ = factory setting. () = display text [] = value for use in communication via serial communication port

Function:

Selecting the function of the frequency converter after a stop command and the frequency has been ramped down to the settings of parameter 123.

Description of choice:

Select *Coasting* [0] The frequency converter is to leave the motor in free mode.
 Select *DC hold* [1] DC holding current set in parameter 124 is to be activated.
 Select *Motor check* [2] The frequency converter is to check if a motor has been connected.
 Select *Pre-magnetizing* [3]. The magnetic field is built up in the motor while it remains stopped. This ensures that the motor can produce torque as quickly as possible on starting.

123 Min. speed for activating function at stop (MIN.F. FUNC.STOP)

Value:

0 - 600 rpm ★ 0 rpm

Function:

This parameter sets the speed at which the function selected in parameter 122 is to be activated.

Description of choice:

Enter the desired speed.

124 DC holding current (DC-HOLD CURRENT)

Value:

(OFF) - $\frac{I_{VLT,N}}{I_{M,N}} \times 100\%$ ★ 50 %
 0 - 100%

Function:

DC holding current is used to uphold the motor function (holding torque) or to pre-heat the motor.



NB!:

The maximum value depends on the rated motor current.

Description of choice:

This parameter can only be used if *DC hold* [1] has been selected in parameter 121 or 122. Set *Holding current* as a percentage value in relation to the rated motor current $I_{M,N}$ set in parameter 105. 100% DC holding current corresponds to $I_{M,N}$.



Warning: 100 % current for too long may damage the motor.

125 DC braking current

(DC BRAKE CURRENT)

Value:

0 (OFF) - $\frac{I_{VLT,MAX}}{I_{M,N}} \times 100\%$ ★ 50 %
 0 - 160%

Function:

Setting the DC brake current when a stop command is applied. The function is activated when the set speed in parameter 127 has been reached, or the *DC Brake Inverse* is active on terminal 27 and parameter 304, or via the serial communication port. The braking current is active during the time period set in parameter 126.



NB!:

The maximum value depends on the rated motor current.

Description of choice:

To be set as a percentage value of the rated motor current $I_{M,N}$ set in parameter 105. 100% DC braking current corresponds to $I_{M,N}$.



Warning: 100 % current for too long may damage the motor.

126 DC braking time

(DC BRAKING TIME)

Value:

0.0 (OFF) - 60.0 sec. ★ 10.0 sec.

Function:

Setting the DC braking time for which the DC braking current (parameter 125) is active.

Description of choice:

Set the DC braking time.

127 DC brake cut-in speed

(DC BRAKE CUT-IN)

Value:

0.0 - parameter 202 ★ 0.0 rpm (OFF)

Function:

Setting the DC brake cut-in speed at which the DC braking current (parameter 125) is active, in connection with a stop command.

Description of choice:

Set the cut-in speed.

128 Motor thermal protection

(MOT.THERM PROTEC)

Value:

★No protection (NO PROTECTION)	[0]
Thermistor warning (THERMISTOR WARN)	[1]
Thermistor trip (THERMISTOR TRIP)	[2]
ETR Warning 1 (ETR WARNING1)	[3]
ETR Trip 1 (ETR TRIP1)	[4]
ETR Warning 2 (ETR WARNING2)	[5]
ETR Trip 2 (ETR TRIP2)	[6]
ETR Warning 3 (ETR WARNING3)	[7]
ETR Trip 3 (ETR TRIP3)	[8]
ETR Warning 4 (ETR WARNING 4)	[9]
ETR Trip 4 (ETR TRIP4)	[10]

Function:

The frequency converter can detect the motor temperature for motor protection in two different ways:

- Via a thermistor sensor connected to one of the analogue inputs, terminals 53 and 54 (parameter 308 and 311).
- Calculation of the thermal load, based on the actual load and time. This is compared with the rated motor current $I_{M,N}$ and the rated motor frequency $f_{M,N}$. The calculations made take into account the need for a lower load at lower speeds because of less cooling from the fan.

ETR (Electronic Terminal Relay) functions 1-4 do not start calculating the load until there is a switch-over to the Setup in which they were selected. For the North American market: The ETR functions provide class 20 motor overload protection in accordance with NEC.

Description of choice:

Select *No protection* if no warning or tripping is required if the motor is overloaded.

Select *Thermistor warning* if a warning is desired when the connected thermistor in the motor gets too hot.

★ = factory setting. () = display text [] = value for use in communication via serial communication port

Select *Thermistor trip* if cutting out (trip) is desired when the connected thermistor in the motor gets too hot. Select *ETR Warning 1-4*, if a warning is to come up on the display when the motor is overloaded according to the calculations.

Select *ETR Trip 1-4* if tripping is desired when the motor is overloaded according to the calculations. A warning signal can be programmed via one of the digital outputs, in which case the signal is given both for warning and for trip (thermal warning).

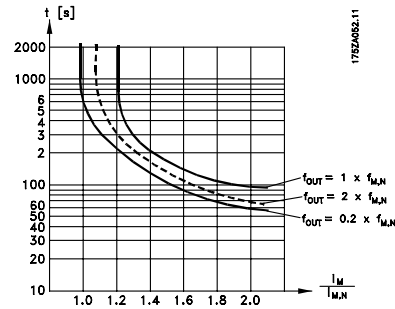

129 External motor fan

(MOTOR EXTERN FAN)

Value:

★No (NO)	[0]
Yes (YES)	[1]

Function:

This parameter informs the frequency converter whether the motor has an external separately supplied fan (external ventilation), indicating that derating at low speed is unnecessary.

Description of choice:

If Yes [1] is selected, the graph below is followed if the motor frequency is lower. If the motor frequency is higher, the time will still derate as if no fan had been installed.

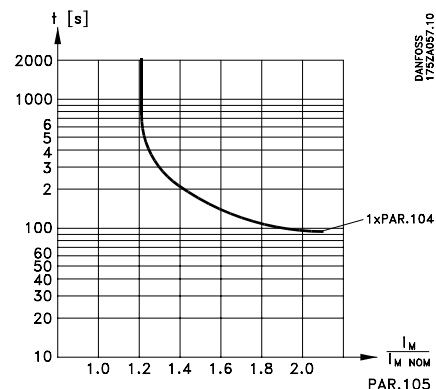

130 Start speed
(START SPEED)
Value:

 0.0 - 600 rpm ★ 0.0 rpm
Function:

This parameter allows setting of the output speed at which the motor is to start.

The output speed 'leaps' to the set value. This parameter can be used e.g. for hoist applications (cone armature motors).

Description of choice:

Set the desired start speed.

It is assumed that the start function in parameter 121 has been set to [3], [4] or [5] and that a start delay time has been set in parameter 120; also, a reference signal must be present.

131 Initial current
(INITIAL CURRENT)
Value:

 0.0 - parameter 105 ★ 0.0 Amp
Function:

Some motors, such as cone rotor motors, need extra current/starting speed (boost) when starting to disengage the mechanical brake.

For this purpose use parameter 130/131.

Description of choice:

Set the desired value required to disengage the mechanical brake.

It is assumed that the start function in parameter 121 has been set to [3] or [4] and that a start delay time has been set in parameter 120; also, a reference signal must be present.

★ = factory setting. () = display text [] = value for use in communication via serial communication port

■ Additional Motor Parameters

The motor data in parameter 150-158 must be matching the specific motor, in order for the motor to run properly. Factory settings are figures based on common motor parameter values from normal standard motors. If the motor parameters are not set correctly, it may cause a malfunction of the drive system. If the motor data is not known it is recommended to perform an AMA (Automatic Motor Adaptation). See section *Automatic Motor Adaptation*. The AMA sequence will adjust all motor parameters except the moment of inertia of the rotor.

Motor equivalent diagram for an asynchronous motor:

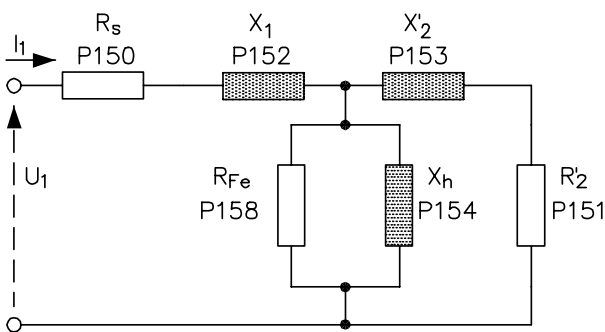

175ZA754.10



NB!

If the settings in parameters 102-106 are changed, parameters 150-158 will return to factory default settings.

150 Stator resistance (STATOR RESIST)

Value:

Ohm ★ Depends on unit

Function:

Sets the value of the motor stator resistance for the Flux Vector control.

151 Rotor resistance (ROTOR RESIST)

Value:

Ohm ★ Depends on unit

Function:

A manually entered Rotor resistance, R_2' must apply to a cold motor. Shaft performance can be improved by fine-tuning R_2' .

Description of choice:

R_2' can be set as follows:

★ = factory setting. () = display text [] = value for use in communication via serial communication port

1. Automatic Motor Adaptation, where the frequency converter measures on the motor to determine the value. All compensations are reset to 100%.
2. The motor supplier states the value.
3. The factory settings of R_2' , selected by the frequency converter itself on the basis of the motor nameplate data, is used.

152 Stator Leakage Reactance

(STATOR LEAKAGE)

Value:

Ohm ★ Depends on unit

Function:

Set the stator leakage reactance of the motor.

Description of choice:

X_1 can be set as follows:

1. Automatic Motor Adaptation, where the frequency converter measures on the motor to determine the value.
2. The motor supplier states the value.
3. The factory setting of X_1 , selected by the frequency converter itself on the basis of the motor nameplate data, is used.

153 Rotor Leakage Reactance

(ROTOR LEAKAGE)

Value:

Ohm ★ Depends on unit

Function:

Set the rotor leakage reactance of the motor.

Description of choice:

X_2 can be set as follows:

1. Automatic Motor Adaptation, where the frequency converter measures on the motor to determine the value.
2. The motor supplier states the value.
3. The factory setting of X_2 , selected by the frequency converter itself on the basis of the motor nameplate data, is used.

154 Main Reactance (MAIN REACTANCE)

Value:

Ohm ★ Depends on unit

Function:

Set the main reactance of the motor.

Description of choice:

X_h can be set as follows:

1. Automatic Motor Adaptation, where the frequency converter measures on the motor to determine the value.
2. The motor supplier states the value.
3. The factory setting of X_h , selected by the frequency converter itself on the basis of the motor nameplate data, is used.

156 Pole Number (POLE NUMBER)

Value:

Depends on motor type
Value 2 - 100 poles ★ 4-pole motor

Function:

Set the pole number of the motor

Description of choice:

Poles	~ n_n @ 50 Hz	~ n_n @ 60Hz
2	2700 - 2880	3250 - 3460
4	1350 - 1450	1625 - 1730
6	700 - 960	840 - 1153

The above table shows the normal speed range for various motor types. Motors designed for other frequencies must be defined separately.

158 Iron loss Resistance (IRONLOSS RES.)

Value:

1 - 10.000Ω ★ 10.000Ω

Function:

Set the equivalents of the R_{Fe} to compensate for iron losses in the motor.

Description of choice:

The function is switched off when the value 10.000 is chosen.

The Iron loss resistance must be less than:

$$R_{Fe} < P_0 / I_0^2$$

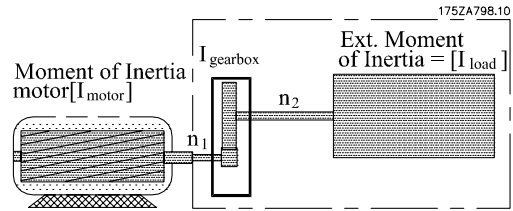

$$\text{Max Moment of Inertia} = I_{motor} + I_{gearbox} + I_{load} * (n_2/n_1)^2$$

161 Minimum Inertia (MINIMUM INERTIA)

Value:

[kgm²] ★ Depends on unit

Function:

Set the minimum moment of Inertia of the mechanical system.

Description of choice:

The frequency converter calculates the proportional gain for the speed controller based on the mean value of minimum and maximum inertia.

Converting factors:

To convert from	To	Multiplication Factor
ft lbs s ²	kgm ²	1.356
lbf in ²	kgm ²	2.926*10 ⁻⁴
kgcm ²	kgm ²	*10 ⁻⁴
GD ²	kgm ²	0.25

162 Maximum Inertia (MAXIMUM INERTIA)

Value:

[kgm²] ★ Depends on the unit

Function:

Set the maximum moment of Inertia of the mechanical system.

Description of choice:

See parameter 161.

★ = factory setting. () = display text [] = value for use in communication via serial communication port

163 Functional Stop Delay
(FUNC. STOP DELAY)

Value:

0-10 sec. ★ 0

Function:

When stopping, this delay postpones the change to the selected stop-function, unless DC-brake is enabled. During this delay, the shaft will be held at zero speed with full holding torque.

Description of choice:

Ensuring that the mechanical brake has locked the load before the motor is in coast mode.
See *Mechanical brake control*.

164 Mechanical Brake Release Delay
(BRAKE REL. DELAY)

Value:

0.01-2.00 sec ★ 0.50 sec

Function:

When Mechanical Brake Release is selected as start-function in Parameter 121, this delay describes the time it takes for the brake to open. During this delay, the motor will be held a 0 RPM.

165 Mechanical Brake Initial Torque
(BRAKE INI TORQUE)

Value:

+/- p221 ★ 20%

Function:

When Mechanical Brake Release is selected as a start-function in Parameter 121, this torque-level will be built up against the closed brake prior to brake release. When using the drive in a crane, lift or hoist application with a mechanical brake, this torque should be set to a value equal to the torque present, when the brake opens.

166 Mechanical Brake Initial Direction
(BRAKE INIT DIR)

Value:

[Clockwise]
[Ref. dir.] ★ [Clockwise]

Function:

When Mechanical Brake Release is selected as a start-function in Parameter 121, this Parameter

★ = factory setting. () = display text [] = value for use in communication via serial communication port

determines the direction of the initial torque applied against the closed brake. In a crane application the load will always be in the same direction, but in other applications it may make sense to apply the torque in the same direction as the reference.

167 Proportional Gain Boost, during Mechanical Brake Release
(BRAKE GAIN BOOST)

Value:

0-400% ★ 100%

Function:

When Mechanical Brake Release is selected as start-function in Parameter 121, this Parameter defines an extra gain on P-part (Par. 417) of speed PI-controller during the Mechanical Release Delay (Par. 164). Boosting the proportional gain, will minimise the small movement on the motorshaft when motor takes over the load from the mechanical brake.

■ References and limits
■ Introduction

The purpose of the parameter group 2xx is selecting and adjusting references, ramping times and setting limits for warnings.

Actual reference	Resulting reference for speed/torque
External reference	Reference on Terminals 53, 54 or 60, and puls and bus references
Preset reference	Reference value from the internal four presets.

PNU #	Parameter description	Factory setting	Range	Changes during operation	4-Setup	Conversion index	Data type
200	Output speed range/direction	Only clockwise, 0-4500 rpm		No	Yes	0	5
202	Output speed high limit	3000 rpm	n _{MIN} - par. 200	No	Yes	-1	6
203	Reference Range	Min - max		Yes	Yes	0	5
204	Minimum reference	0.000	-100,000.000-Ref _{MAX}	Yes	Yes	-3	4
205	Maximum reference	1500.000	Ref _{MIN} -100,000.000	Yes	Yes	-3	4
206	Ramp type	Linear		Yes	Yes	0	5
207	Ramp-up time 1	Depends on unit	0.01 - 3600	Yes	Yes	-2	7
208	Ramp-down time 1	Depends on unit	0.01 - 3600	Yes	Yes	-2	7
209	Ramp-up time 2	Depends on unit	0.01 - 3600	Yes	Yes	-2	7
210	Ramp-down time 2	Depends on unit	0.01 - 3600	Yes	Yes	-2	7
211	Jog ramp time	Depends on unit	0.01 - 3600	Yes	Yes	-2	7
212	Quick stop ramp-down time	Depends on unit	0.01 - 3600	Yes	Yes	-2	7
213	Jog speed	200 rpm	0.0 - par. 202	Yes	Yes	-1	6
214	Reference function	Sum		Yes	Yes	0	5
215	Preset reference 1	0.00 %	- 100.00 - 100.00 %	Yes	Yes	-2	3
216	Preset reference 2	0.00 %	- 100.00 - 100.00 %	Yes	Yes	-2	3
217	Preset reference 3	0.00 %	- 100.00 - 100.00 %	Yes	Yes	-2	3
218	Preset reference 4	0.00 %	- 100.00 - 100.00 %	Yes	Yes	-2	3
219	Catch up/slow down value	0.00 %	0.00 - 100 %	Yes	Yes	-2	6
221	Torque limit for motor mode	160 %	0.0 % - xxx %	Yes	Yes	-1	6
222	Torque limit for generating operation	160 %	0.0 % - xxx %	Yes	Yes	-1	6
223	Warning: Low current	0.0 A	0.0 - par. 224	Yes	Yes	-1	6
224	Warning: High current	lv _{LT,MAX}	Par. 223 - lv _{LT,MAX}	Yes	Yes	-1	6
225	Warning: Low speed	0 rpm	0 - par. 226	Yes	Yes	-1	6
226	Warning: High speed	100.000 rpm	Par. 225 - par. 202	Yes	Yes	-1	6
234	Motor phase monitor	Enable		Yes	Yes	0	5
235	Phase loss monitor	Enable		No	No	0	5
236	Low Speed Current	100%	0 – Motor size depended	Yes	Yes	0	6
237	Model Shift Speed	20% of n _{nom}	10 Hz	Yes	No	0	6
240	Acceleration Jerk 1	33%	0-100%	No	No	0	U16
241	Acceleration Jerk 2	33%	0-100%	No	No	0	U16
242	Deceleration Jerk 1	33%	0-100%	No	No	0	U16
243	Deceleration Jerk 2	33%	0-100%	No	No	0	U16

Programming

★ = factory setting. () = display text [] = value for use in communication via serial communication port

See also *Operation and Display* for further information regarding Changes during operation, 4-Setup and Conversion index.

200 Output speed range/direction (OUT SPEED RNG/ROT)

Value:

- ★Only clockwise, 0-4500 rpm
(4500 RPM CLOCK WISE) [0]
- Both directions, 0-4500 rpm
(4500 RPM BOTH DIRECT.) [1]
- Only clockwise, 0-18000 rpm
(18000 RPM CLOCK WISE) [2]
- Both directions, 0-18000 rpm
(18000 RPM BOTH DIRECT.) [3]

Function:

This parameter prevents unwanted reversing. Furthermore, the maximum output speed can be selected regardless of the settings of other parameters.

Description of choice:

Select the desired direction as well as output speed. Note that if *Clockwise, 0-4500 rpm* [0], *Clockwise, 0-18000 rpm* [2], is selected, the output speed will be limited to the range $n_{MIN} - n_{MAX}$ (parameter 202). If *Both directions, 0-4500 rpm* [1] or *Both directions, 0-18000 rpm* [3] is selected, the output speed will be limited to the range $\pm n_{MAX}$.

Example:

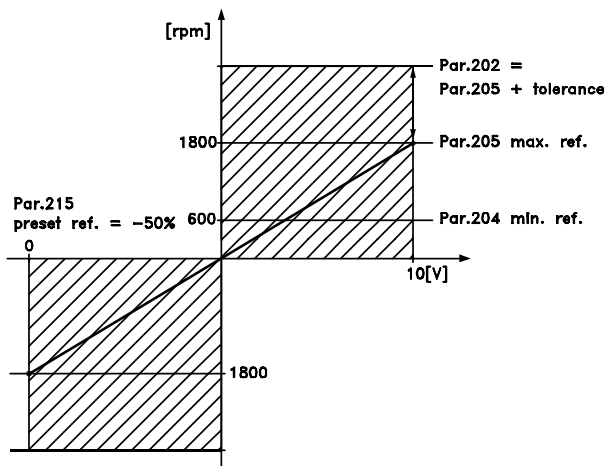

175ZA750.12

Parameter 200 Output speed range/direction = both directions.

202 Output speed high limit (n_{MAX}) (OUT SPEED HI LIM)

Value:

- 0 - 4500/18000 rpm
(parameter 200) ★ 3000

Function:

A max motor speed can be selected that corresponds to the highest speed at which the motor must run.

★ = factory setting. () = display text [] = value for use in communication via serial communication port

See also parameter 205.

Description of choice:

A value from 0 to the choice made in parameter 200 can be selected.

203 Reference/feedback area (REF/FEEDB. RANGE)

Value:

- ★Min - Max (MIN - MAX) [0]
- Max - + Max (-MAX-+MAX) [1]

Function:

This parameter decides whether the reference signal and the feedback signal are to be positive or can be both positive and negative. The minimum limit may be a negative value, unless *Speed control, closed loop* has been selected (parameter 100).

Description of choice:

Choose the desired range.

204 Minimum reference (MIN. REFERENCE)

Value:

- 100,000.000 - Ref_{MAX} ★ 0.000
- Depends on parameter 100.

Function:

The *Minimum reference* gives the minimum value that can be obtained by the sum of all references. *Minimum reference* is only active if *Min - Max* [0] has been set in parameter 203.

Description of choice:

Is only active when parameter 203 has been set to *Min - Max* [0].

Set the desired value.

The unit follows the choice of configuration in parameter 100.

- Speed control, closed loop: rpm
- Torque control, speed feedback: Nm

205 Maximum reference (MAX. REFERENCE)

Value:
Ref_{MIN} - 100,000.000 ☆ 1500.000

Function:
The *Maximum reference* gives the highest value that can be obtained by the sum of all references.

Description of choice:
The unit follows the choice of configuration in parameter 100.

Speed control, closed loop: rpm
Torque control, speed feedback: Nm

206 Ramp type (RAMP TYPE)

Value:
☆Linear (LINEAR) [0]
Sinusoidal (S1) [1]
Sin² (S2) [2]
Jerk Ctrl [3]

Function:
There is a choice of 4 different ramp types.

Description of choice:

Select the desired ramp type, depending on requirements for acceleration/deceleration.

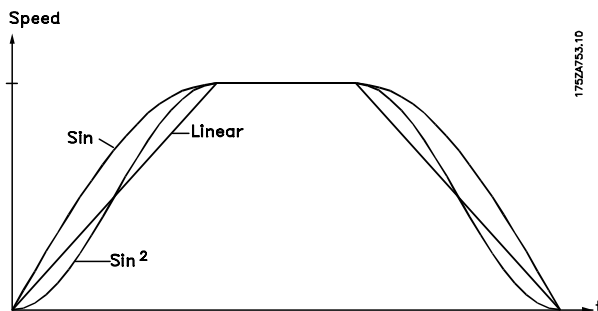

207 Ramp-up time 1 (RAMP UP TIME 1)

Value:

0.00 - 3600 sec. (closed loop)
0.05 - 3600 sec. (open loop) ☆ depends on unit

Function:

The ramp-up time is the acceleration time from 0 rpm to the rated motor speed n_{M,N} (parameter 104). This presupposes that the output current does not reach the torque limit (to be set in parameter

221). Please note, that the value 0.00 corresponds to 0.01 sec. in speed mode.

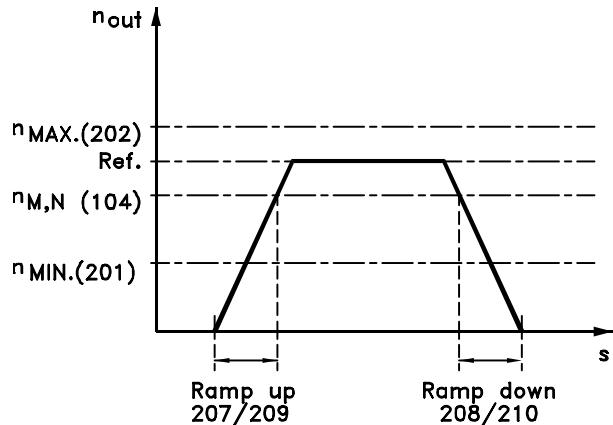

1752A751.10

Description of choice:

Set the desired ramp-up time.

208 Ramp-down time 1 (RAMP DOWN TIME 1)

Value:

0.00 - 3600 sec. (closed loop)
0.05 - 3600 sec. (open loop) ☆ depends on unit

Function:

The ramp-down time is the deceleration time from the rated motor speed n_{M,N} (parameter 104) to 0 rpm, provided there is no over-voltage in the inverter because of regenerative operation of the motor, or if the generated current reaches the torque limit (to be set in parameter 222). Please note, that the value 0.00 corresponds to 0.01 during speed.

Description of choice:

Set the desired ramp-down time.

209 Ramp-up time 2 (RAMP UP TIME 2)

Value:

0.00 - 3600 sec. (closed loop)
0.05 - 3600 sec. (open loop) ☆ depends on unit

Function:

See description of parameter 207. Please note, that the value 0.00 corresponds to 0.01 during speed.

Description of choice:

Set the desired ramp-up time.

☆ = factory setting. () = display text [] = value for use in communication via serial communication port

Switching to ramp 2 may be activated via a signal on digital input terminal 16, 17, 29, 32 or 33. Ramp 1 will then be disabled.

210 Ramp-down time 2 (RAMP DOWN TIME 2)

Value:
0.00 - 3600 sec. (closed loop)
0.05 - 3600 sec. (open loop) ★ depends on unit

Function:
See description of parameter 208. Please note, that the value 0.00 corresponds to 0.01 during speed.

Description of choice:
Set the desired ramp-down time. Switching to ramp 2 is effected via a signal on digital input terminal 16, 17, 29, 32 or 33. Ramp 1 will then be disabled.

211 Jog ramp time (JOG RAMP TIME)

Value:
0.00 - 3600 sec. (closed loop)
0.05 - 3600 sec. (open loop) ★ depends on unit

Function:
The jog ramp time is the acceleration/deceleration time from 0 rpm to the rated motor frequency $n_{M,N}$ (parameter 104). It is assumed that the output current is not higher than the torque limit (set in parameter 221).

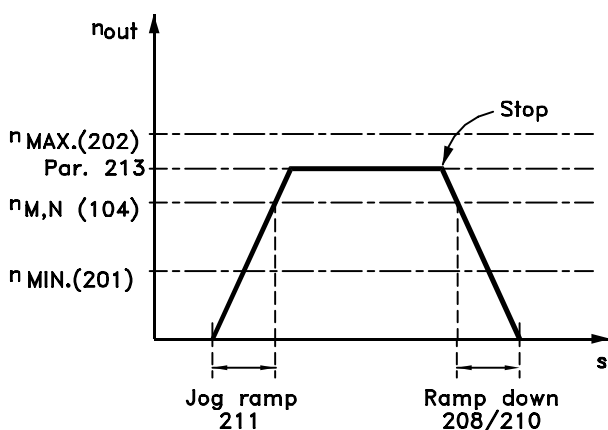

175ZA752.10

The jog ramp time starts when a jog signal is given via the control panel, the digital inputs or the serial communication port.

Description of choice:
Set the desired ramp time.

212 Quick stop ramp-down time (Q STOP RAMP TIME)

Value:
0.00 - 3600 sec. (closed loop)
0.05 - 3600 sec. (open loop) ★ depends on unit

Function:
The ramp-down time is the deceleration time from the rated motor speed to 0 rpm, provided no over-voltage arises in the inverter because of generating operation of the motor or if the generated current becomes higher than the torque limit (set in Parameter 222). Quick-stop is activated by means of a signal on digital input terminal 27 [2], or via the serial communication port.

Description of choice:
Program the desired ramp-down time.

213 Jog speed (JOG SPEED)

Value:
0.0 - Parameter 202 ★ 200 rpm

Function:
The jog speed n_{JOG} is a fixed output speed at which the frequency converter is running when the jog function is activated.

Description of choice:
Set the desired frequency.

214 Reference function (REF FUNCTION)

Value:
★ Sum. (SUM) [0]
Relative (RELATIVE) [1]
External/preset (EXTERNAL/PRESET) [2]

Function:
To define how the preset references are to be added to the other references. For this purpose, *Sum* or *Relative* is used. It is also possible - by using the *External/preset* function - to select whether a shift between external references and preset references is desired.

Description of choice:
If *Sum* [0] is selected, one of the adjusted preset references (parameters 215-218) is added as a percentage of the maximum possible reference.

★ = factory setting. () = display text [] = value for use in communication via serial communication port

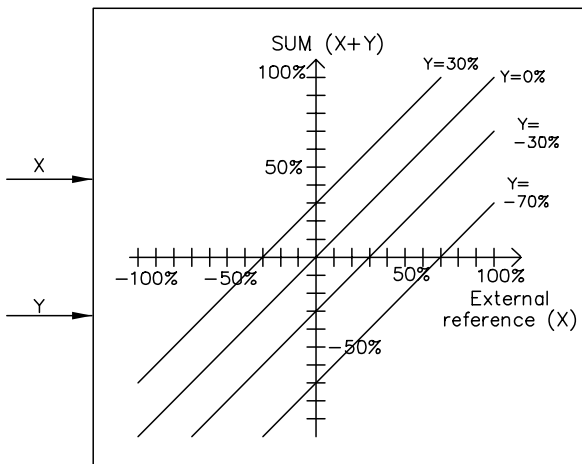

175ZA767.10

If *Relative* [1] is selected, one of the adjusted preset references (parameters 215-218) is added to the external references as a percentage of the actual reference.

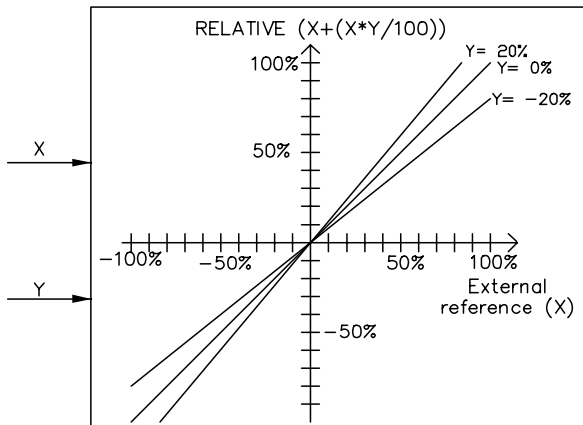

175ZA768.10

If *External/preset* [2] is selected, it is possible to shift between external references or preset references via terminal 16, 17, 29, 32 or 33 (parameter 300, 301, 305, 306 or 307). Preset references will be a percentage value of the reference range. External reference is the sum of the analogue references, pulses and bus references. See also section *Reference Handling*.



NBI:

If *Sum* or *Relative* is selected, one of the preset references will always be active. If the preset references are to be without influence, they must be set to 0 % (factory setting).

The example shows how to calculate the output speed by using *Preset references* together with *Sum* and *Relative* in parameter 214.

Parameter 205 *Maximum reference* has been set to 1500 rpm.

Par. 204 <i>Min. reference</i>	In-crease [rpm/V]	Speed by 4.0 V [rpm]	Par. 215 <i>Preset ref.</i>	Par. 214 Reference type = <i>Sum</i> [0]	Par. 214 Reference type = <i>Relative</i> [1]
1) 0	150	600	15 %	Output speed [rpm] 0+600+225 = 825	Output speed 0+600+90 = 600
2) 300	120	480	15 %	300+480+180=960	300+480+72 = 852
3) 600	90	360	15 %	600+360+135=1095	600+360+54=1014
4) 900	60	240	15 %	900+240+90=1230	900+240+36=1176
5) 1200	30	120	15 %	1200+120+45=1365	1200+120+18=1338

★ = factory setting. () = display text [] = value for use in communication via serial communication port

The values are valid for a 4 pole asynchronous motor.

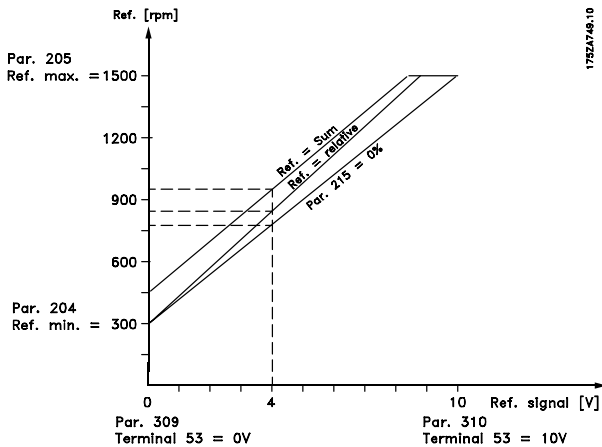

215 Preset reference 1 (PRESET REF. 1)

216 Preset reference 2 (PRESET REF. 2)

217 Preset reference 3 (PRESET REF. 3)

218 Preset reference 4 (PRESET REF. 4)

Value:
-100.00 % - +100.00 % ★ 0.00%
of the reference range/external reference

Function:
Four different preset references can be programmed in parameters 215-218. The preset reference is stated as a percentage of the value Ref_{MAX} or as a percentage of the other external references, depending on the choice made in parameter 214. If a Ref_{MIN} ≠ 0 has been programmed, the preset reference as a percentage will be calculated on the basis of the difference between Ref_{MAX} and Ref_{MIN}, following which the value is added to Ref_{MIN}.

Description of choice:
Set the fixed reference(s) that is/are to be obtained. To use the fixed references, it is necessary to have selected Preset ref. enable on terminal 16, 17, 29, 32 or 33. Choices between fixed references can be made by activating terminal 16, 17, 29, 32 or 33 - see the table below.

Terminals 17/29/33 preset ref. msb	Terminals 16/29/32 preset ref. lsb	
0	0	Preset ref. 1
0	1	Preset ref. 2
1	0	Preset ref. 3
1	1	Preset ref. 4

See drawing in section *Handling of multi-references* .

219 Catch up/slow down value (CATCH UP/SLW DWN)

Value:
0.00-100% of the current reference ★ 0.00%

Function:
This parameter enables the entry of a percentage value (relative) which will either be added to or deducted from the actual reference.

Description of choice:
If *Catch up* has been selected via one of the terminals 16, 29 or 32 (parameters 300, 305 and 306), the percentage (relative) value selected in parameter 219 will be added to the total reference. If *Slow down* has been selected via one of the terminals 17, 29 or 33 (parameters 301, 305 and 307), the percentage (relative) value selected in parameter 219 will be deducted from the total reference.

221 Torque limit for motor mode (TORQ LIMIT MOTOR)

Value:
0.0 % - xxx.x % of T_{M,N} ★ 160 % of T_{M,N}
The max. torque depends on the unit, the selected motor size and parameters.

Function:
This parameter sets the torque limit for motor operation. The torque limiter is active in the speed range up to the rated motor speed (parameter 106).

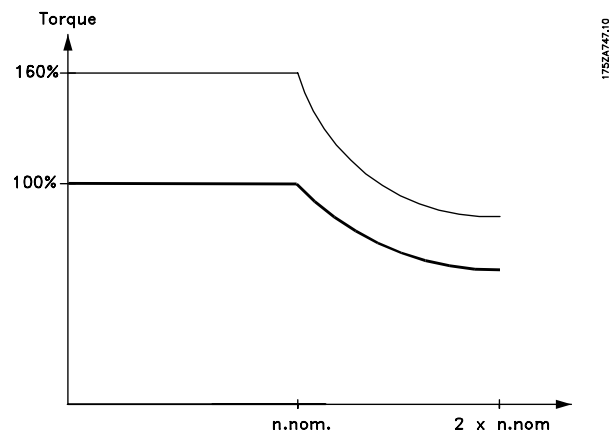

★ = factory setting. () = display text [] = value for use in communication via serial communication port

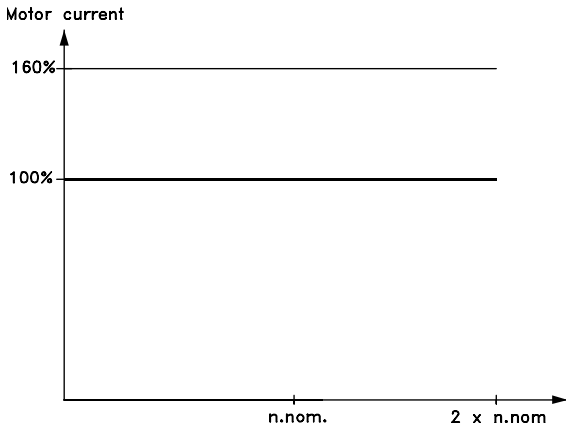

1752A746.10



Changing parameter 222 (TORQ LIMIT GENER) when parameter 100 is set to SPEED OPEN LOOP (0), parameter 236 (LOW SPEED CURRENT) will automatically be readjusted. If parameter 222 > parameter 236, a potential risk for motor stalling occurs.

Description of choice:

See also parameter 409 for further details.
 In order to protect the motor from reaching pull-out torque, the factory setting is 1.6 x the rated motor torque (calculated value).
 If a setting in parameters 101-106 is changed, parameters 221/222 are not automatically reversed to the factory setting.



Changing parameter 221 (TORQ LIMIT MOTOR) when parameter 100 is set to SPEED OPEN LOOP (0), parameter 236 (LOW SPEED CURRENT) will automatically be readjusted. If parameter 221 > parameter 236, a potential risk for motor stalling occurs.

222 Torque limit for generating operation (TORQ LIMIT GENER)

Value:
 0.0 % - xxx.x % of $T_{M,N}$ ★ 160 % of $T_{M,N}$
 The max. torque depends on the unit, the selected motor size and parameters.

Function:

This parameter sets the torque limit for generating operation. The torque limiter is active in the speed range up to the rated motorspeed (parameter 104). See fig. for parameter 221 as well as parameter 409 for further details.

Description of choice:

If Resistor brake [1] has been selected in parameter 400, the torque limit is changed to 1.6 x the rated motor torque.

223 Warning: Low current (WARN. CURRENT LO)

Value:
 0.0 - parameter 224 ★ 0.0 A

Function:

When the motor current is below the limit, I_{LOW} , the display indicates CURRENT LOW, except if mechanical brake control is selected.
 The signal outputs can be programmed to produce a status signal on terminal 26 or 46 as well as on relay output 01 or 04 (parameter 319, 321, 323 or 326).

Description of choice:

The lower signal limit I_{LOW} of the motor current must be programmed within the normal working range of the frequency converter.

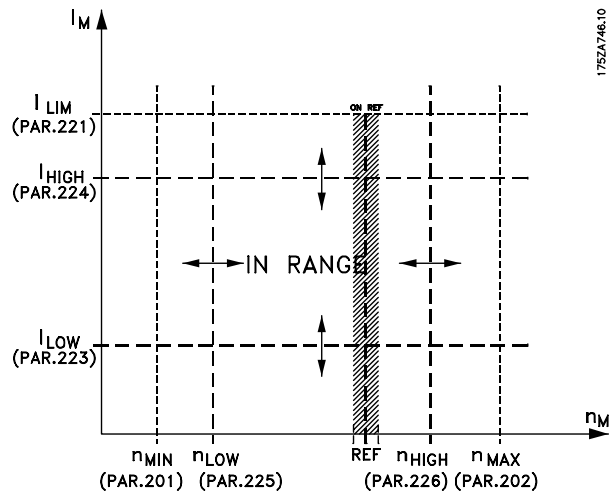

1752A746.10

224 Warning: High current (WARN. CURRENT HI)

Value:
 Parameter 223 - $I_{VLT,MAX}$ ★ $I_{VLT,MAX}$

Function:

If the motor current exceeds the programmed limit, I_{HIGH} , the display will indicate CURRENT HIGH.
 The signal outputs can be programmed to produce a status signal on terminal 26 or 46 and on relay output 01 or 04 (parameter 319, 321, 323 or 326).

★ = factory setting. () = display text [] = value for use in communication via serial communication port

Description of choice:

The upper signal limit of the motor current, I_{HIGH} , must be programmed within the normal working range of the frequency converter. See drawing at parameter 223.

225 Warning: Low speed

(WARN. SPEED LOW)

Value:

0 - parameter 226 ★ 0 rpm

Function:

When the motor speed is below the limit, n_{LOW} , the display indicates SPEED LOW.

The signal outputs can be programmed to produce a status signal on terminal 26 or 46 and on relay output 01 or 04 (parameter 319, 321, 323 or 326).

Description of choice:

The lower signal limit of the motor speed, n_{LOW} , must be programmed within the normal working range of the frequency converter. See drawing at parameter 223.

226 Warning: High speed

(WARN. SPEED HIGH)

Value:

parameter 225 - parameter 202 ★ 20.000 rpm

Function:

When the motor speed is above the limit, n_{HIGH} , the display will indicate SPEED HIGH.

The signal outputs can be programmed to produce a status signal on terminal 26 or 46 and on relay output 01 or 04 (parameter 319, 321, 323 or 326).

Description of choice:

The upper signal limit of the motor speed, n_{HIGH} , must be programmed within the normal working range of the frequency converter. See drawing at parameter 223.

234 Motor phase monitor

(MOTOR PHASE MON)

Value:

★Enable (ENABLE) [0]
Disable (DISABLE) [1]

Function:

In this parameter it is possible to select monitoring of the motor phases.

★ = factory setting. () = display text [] = value for use in communication via serial communication port

Description of choice:

If *Enable* is selected, the frequency converter will react on a missing motor phase which will result in alarm 30, 31 or 32.

If *Disable* is selected, **no** alarm is given if a motor phase is missing. The motor can be damaged/overheated if it runs on only two phases. It is therefore recommended to keep the missing motor phase function ENABLED.

235 Phase Loss Monitor

(PHASE LOSS MON.)

Value:

Disable (DISABLE) [0]
★Enable (ENABLE) [1]

Function:

The input phases are monitored for phase loss by this selection.

Description of choice:

If *Enable* is selected, the frequency converter will react on a missing input phase which will result in alarm 4. If *Disable* is selected, **no** alarm is given if a supply phase is missing. The frequency converter can be damaged when operating with a missing input phase. It is therefore recommended to keep the phase loss monitor ENABLED.

236 Low Speed current

(LOW SPEED CURRENT)

Value:

0 - max 255% of nominal motor current
Parameter 105.

★ 100%

Function:

This function is enabled when parameter 100 = *SPEED OPEN LOOP* only. VLT 5000 FLUX is running with constant current through motor below 10 Hz. When speed is above 10 Hz, the motor flux model in the drive will control the motor. Parameter 236 is automatically adjusted by parameters 221 and / or parameter 222, depending on which of the two parameters has the highest value. The current in parameter 236 is composed of the torque generating current and the magnetizing current.

Ex. Parameter 221 *Torque limit for motor mode* is set to 100% and parameter 222 *Torque limit for generating mode* is set to 60%, parameter 236 will automatically be set to about 127%, depending on the motor size.

Description of choice:



NB!:

If the motor is running below 10 Hz for a longer period than one minute, parameter 236 must be reduced accordingly to avoid that the motor burns out.

237 Model Shift Speed

(MODEL SHIFT SPEED)

Value:

2 Hz .. 80% of n_{norm}

★ 10 Hz (default and n_{norm} dependent)

Function:

With this parameter it is possible to make an adjustment of the shifting point where VLT 5000 FLUX changes the FLUX model in the DSP.

Parameter 100 TORQUE CONTROL SPEED [5] mode:

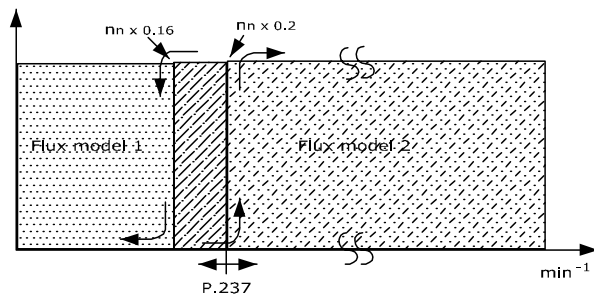

175ZA879.10

Parameter 100 OPEN LOOP [0] mode:

In open loop, the speed must be determined from the current measurement. Below $n_{norm} \times 0.2$, the drive is working from a constant current model. Above $n_{norm} \times 0.2$ the drive is working from the FLUX model in the drive.

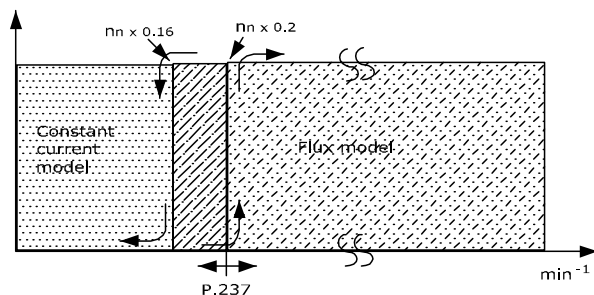

175ZA878.10

Description of choice:

Constant Torque mode: To optimize the torque control it may be necessary to run on one FLUX model only to avoid any bump during the change of FLUX model. Max speed for FLUX model 1 is $n_{norm} - 10\%$.

Open Loop mode: To optimize the switching point from constant current set in parameter 236 and FLUX model 2.

240 Acceleration Jerk 1 (JERK ACCEL. 1)

Value:

0-100%

★ 33%

Function:

If Jerk Control is selected as ramp-type in Parameter 206, this Parameter defines the percentage of the ramp-time used to control the jerk of the initial acceleration.

241 Acceleration Jerk 2 (JERK ACCEL. 2)

Value:

0-100%

★ 33%

Function:

If Jerk Control is selected as ramp-type in Parameter 206, this Parameter defines the percentage of the ramp-time used to control the jerk of the ending acceleration.

242 Deceleration Jerk 1 (JERK DECCL. 2)

Value:

0-100%

★ 33%

Function:

If Jerk Control is selected as ramp-type in Parameter 206, this Parameter defines the percentage of the ramp-time used to control the jerk of the initial deceleration.

243 Deceleration Jerk 2 (JERK DECCL. 2)

Value:

0-100%

★ 33%

Function:

If Jerk Control is selected as ramp-type in Parameter 206, this Parameter defines the percentage of the ramp-time used to control the jerk of the ending deceleration.

■ Introduction

Parameter group 3xx selects the analogue and digital inputs and outputs to the desired function. Also scaling of the inputs and outputs is performed in this group. Inputs: Max frequency on inputs terminal 16, 17, 18, 19, 27, 32, and 33 is 5 kHz. (24Vpp). Max frequency on inputs terminal 29 is 65 kHz (24Vpp).

Max frequency for the encoder inputs terminal 73 - 78 is 250 kHz (5Vpp). Outputs: Analogue outputs terminal 42 and 45 are scaleable current outputs. Max frequency on digital outputs terminal 26 and 46 is 50kHz.

PNU #	Parameter description	Factory setting	Range	Changes during operation	4-Setup	Conversion index	Data type
300	Terminal 16, input	Reset		Yes	Yes	0	5
301	Terminal 17, input	Freeze reference		Yes	Yes	0	5
302	Terminal 18 Start, input	Start		Yes	Yes	0	5
303	Terminal 19, input	Reversing		Yes	Yes	0	5
304	Terminal 27, input	Coasting stop, inverse		Yes	Yes	0	5
305	Terminal 29, input	Jog		Yes	Yes	0	5
306	Terminal 32, input	Choice of setup, msb/speed up		Yes	Yes	0	5
307	Terminal 33, input	Choice of setup, lsb/speed down		Yes	Yes	0	5
308	Terminal 53, analogue input voltage	Reference		Yes	Yes	0	5
309	Terminal 53, min. scaling	0.0 V	0.0 - 10.0 V	Yes	Yes	-1	5
310	Terminal 53, max. scaling	10.0 V	0.0 - 10.0 V	Yes	Yes	-1	5
311	Terminal 54, analogue input voltage	No operation		Yes	Yes	0	5
312	Terminal 54, min. scaling	0.0 V	0.0 - 10.0 V	Yes	Yes	-1	5
313	Terminal 54, max. scaling	10.0 V	0.0 - 10.0 V	Yes	Yes	-1	5
314	Terminal 60, analogue input current	Reference		Yes	Yes	0	5
315	Terminal 60, min. scaling	0.0 mA	0.0 - 20.0 mA	Yes	Yes	-4	5
316	Terminal 60, max. scaling	20.0 mA	0.0 - 20.0 mA	Yes	Yes	-4	5
317	Time out	10 sec.	0 - 99 sec.	Yes	Yes	0	5
318	Function after time out	Off		Yes	Yes	0	5
319	Terminal 42, output	0 - n _{MAX} 0-20 mA		Yes	Yes	0	5
321	Terminal 45, output	0 - n _{MAX} 0-20 mA		Yes	Yes	0	5
323	Relay 01, output	No operation		Yes	Yes	0	5
324	Relay 01, ON delay	0.00 sec.	0.00 - 600.00 sec.	Yes	Yes	-2	6
325	Relay 01, OFF delay	0.00 sec.	0.00 - 600.00 sec.	Yes	Yes	-2	6
326	Relay 04, output	No operation		Yes	Yes	0	5
327	Pulse reference, max. frequency	100 - 65000 Hz	5000 Hz	Yes	Yes	0	6
329	Encoder feedback pulse/rev.	1024 pulses/rev.	500 - 10.000 pulses/rev.	Yes	Yes	0	6
341	Terminal 46, digital output	No operation		Yes	Yes	0	5
342	Terminal 46, output, pulse scaling	5000 Hz	1 - 50000 Hz	Yes	Yes	0	6
350	Encoder monitoring	OFF		No	No	0	5
351	Encoder direction	Normal		No	Yes	0	5
355	Terminal 26, digital output	No operation		Yes	Yes	0	5
356	Terminal 26, output, pulse scaling	5000 Hz	1 - 50000 Hz	Yes	Yes	0	6
357	Terminal 42, Output minimum scaling	0 %	000 - 100%	Yes	Yes	0	6
358	Terminal 42, Output maximum scaling	100%	000 - 500%	Yes	Yes	0	6
359	Terminal 45, Output minimum scaling	0 %	000 - 100%	Yes	Yes	0	6
360	Terminal 45, Output maximum scaling	100%	000 - 500%	Yes	Yes	0	6
361	Max Tracking Error	OFF	000 - 999 rpm	Yes	Yes	0	6
362	KTY Sensor Type	KTY1	KTY 1-3	No	Yes	0	5

See also *Operation and Display* for further information regarding Changes during operation, 4-Setup and Conversion index.

★ = factory setting. () = display text [] = value for use in communication via serial communication port

■ Digital Input Functions

Digital inputs	Terminal no.	16	17	18	19	27	29	32	33
	parameter	300	301	302	303	304	305	306	307
Value:		(Operating Command Group)							
No function	(NO OPERATION)	[0]	[0]	[0]	[0]		[0]	[0]	[0]
Reset	(RESET)	[1]*	[1]				[1]	[1]	[1]
Coasting stop, inverse	(COAST INVERSE)						[0]*		
Reset and coasting stop, inverse	(COAST & RESET INVERS)						[1]		
Quick-stop, inverse	(QSTOP INVERSE)						[2]		
DC-braking, inverse	(DCBRAKE INVERSE)						[3]		
Stop inverse	(STOP INVERSE)	[2]	[2]				[4]	[2]	[2]
Start	(START)						[1]*		
Latched start	(LATCHED START)						[2]		
Reversing	(REVERSING)						[1]*		
Start reversing	(START REVERSE)						[2]		
Only start clockwise, on	(ENABLE START FWD.)	[3]		[3]			[3]	[3]	
Only start anti-clockwise, on	(ENABLE START REV)		[3]		[3]		[4]		[3]
Jog	(JOGGING)	[4]	[4]				[5]*	[4]	[4]
Preset reference, on	(PRESET REF. ON)	[5]	[5]				[6]	[5]	[5]
Preset reference, lsb	(PRESET REF. SEL. LSB)	[6]					[7]	[6]	
Preset reference, msb	(PRESET REF. MSB)		[6]				[8]		[6]
Freeze reference	(FREEZE REFERENCE)	[7]	[7]*				[9]	[7]	[7]
Freeze output	(FREEZE OUTPUT)	[8]	[8]				[10]	[8]	[8]
Speed up	(SPEED UP)	[9]					[11]	[9]	
Speed down	(SPEED DOWN)		[9]				[12]		[9]
Choice of Setup, lsb	(SETUP SELECT LSB)	[10]					[13]	[10]	
Choice of Setup, msb	(SETUP SELECT MSB)		[10]				[14]		[10]
Choice of Setup, msb/speed up	(SETUP MSB/SPEED UP)							[11]*	
Choice of Setup, lsb/speed down	(SETUP LSB/SPEED DOWN)								[11]*
Catch-up	(CATCH UP)	[11]					[15]	[12]	
Slow-down	(SLOW DOWN)		[11]				[16]		[12]
Ramp 2	(RAMP 2)	[12]	[12]				[17]	[13]	[13]
Mains failure inverted	(MAINS FAILURE INVERSE)	[13]	[13]				[18]	[14]	[14]
Pulse reference	(PULSE REFERENCE)						[28]		

Function:
Description of choice:

No function The frequency converter does not react to signals transmitted to the terminal.

Reset Resetting the frequency converter after a TRIP/ALARM; however not all alarms can be reset.

Coasting stop (terminal 27) Inverted input (NC). The frequency converter leaves the motor in free mode. Logic '0' => coasting stop.

Reset and coasting stop (terminal 27) Inverted input (NC). The frequency converter leaves the

motor in free mode and successive resets the drive. Logic '0' => coasting stop and reset.

Quick-stop inverted (terminal 27) Inverted input (NC). Generates stop in accordance with the quick-stop ramp time (Parameter 212). When the motor is stopped the shaft is then in free mode. Logic '0' => Quick-stop.

DC braking inverted (terminal 27) Inverted input (NC). Stopping the motor by energizing it with a DC for a certain time. See parameter 125-127. The function is only active when the value in parameter 126 is different from 0. . Logic '0' => DC braking.

★ = factory setting. () = display text [] = value for use in communication via serial communication port

Stop inverted Inverted function. Generates stop function when the selected terminal goes from logical level '1' to '0'. Stop will be performed according to the selected ramp time (Parameter 207-210).



None of the above-mentioned stop commands (start-disable) are to be used as disconnection switch in connection with repairs. Cut mains instead.



NB!:

Note that when the frequency converter is at the torque limit and has received a stop command, it will only stop if an output terminal (42, 45, 01 or 04) has been connected to terminal 27. The data choice on output terminal 42, 45, 01 or 04 must be *Torque limit* and *stop* [27].

Start is selected if a start/stop (operating command, group 2) command is desired. Logic '1' = start, logic '0' = stop.

Term 12 (+24V)

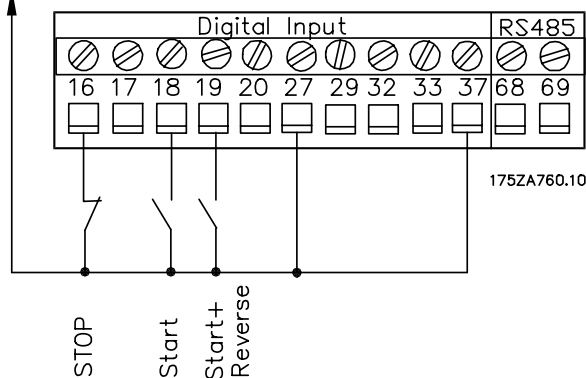

Latched start - if a pulse is applied for min. 3 ms, the motor will start, provided no stop command (operating command, group 2). The motor stops if Stop inverse is activated.

Reversing Changing the direction of rotation of the motor shaft. Logic "1" will lead to reversing. The reversing signal only changes the direction of rotation; it does not activate the start function.

Both directions must be selected in parameter 200. Is not active in *Torque control*, *speed feedback*.

Start reversing, is used for start/stop (operating command, group 2) and for reversing on the same wire. No signal is allowed on terminal 18 at the same time. Acts as latch start reversing, provided latch start has been chosen for terminal 18.

Start clockwise only is used when the motor shaft must rotate clockwise when starting.

Start anti-clockwise only, is used if the motor shaft must rotate counter-clockwise when started.

Jog is used for overriding the output speed to the jog speed set in parameter 213. The ramp time can be set in parameter 211. Jog is not active if a stop command has been given (start-disable). Jog overrides stop (operating command, group 2), see connection example.

Preset reference, on is used for shifting between external reference and preset reference. It is assumed that *External/preset* [2] has been selected in parameter 214. Logic '0' = external references active; logic '1' = one of the four preset references is active in accordance with the table below.

Preset reference, LSB and MSB Selects one of the four preset references, in accordance with the table below.

	Preset ref. msb	Preset ref. lsb
Preset ref. 1	0	0
Preset ref. 2	0	1
Preset ref. 3	1	0
Preset ref. 4	1	1

Freeze reference - freezes the actual reference. The reference is now the point of reference for *Speed up* and *Speed down* to be used. If speed up/down is used, the reference change always follows ramp 2 (parameters 209/210) in the range 0 - Ref_{MAX}.

Freeze output - freezes the actual motor speed (rpm). The frozen motor frequency is now the point of enable/condition for *Speed up* and *Speed down* to be used. If speed up/down is used, the reference change always follows ramp 2 (parameters 209/210) in the range 0 - n_{MAX}.



NB!:

If *Freeze output* is active, the frequency converter cannot be stopped via terminals 18 and 19, but only via terminal 27 (to be programmed for *Coasting stop, inverse* [0] or *Reset and coasting stop, inverse* [1]). However, the frequency converter can always be stopped via the stop signals (*Coasting*, *Quick-stop*, *DC-braking* and *Stop inverse*).

Speed up/Speed down For speed up/down control of speed (motor potentiometer). This function is only active if *Freeze reference* or *Freeze output* has been

★ = factory setting. () = display text [] = value for use in communication via serial communication port

selected. A logic '1' on the terminal selected for speed up, the reference or the output speed will increase.

A logic '1' on the terminal selected for speed down, the reference or the output frequency will be reduced. Pulses (logic '1' minimum high for 3 ms and a minimum pause of 3 ms) will change the speed of 0.1% (reference) or 1 rpm (output speed).

If *Speed up/Speed down* is activated for more than 400 msec., a continuous change using ramp 2 will begin.

Example:

	Terminal		Freeze ref./
	(16)	(17)	Freeze output
No speed change	0	0	1
Speed down	0	1	1
Speed up	1	0	1
Speed down	1	1	1

The speed reference frozen via the control panel can be changed even if the frequency converter has stopped. The frozen reference will be stored in case of a mains cut-out.

Choice of Setup LSB and MSB enables one of the four Setups; however, this depends on the fact that parameter 004 has been set to *Multi Setup*.

Choice of Setup MSB/Speed up and choice of Setup LSB/Speed down - In conjunction with *Freeze reference* or *Freeze output* - enable up/down speed change.

The selection of Setup changes in accordance with the below table:

	Selection of Setup		Freeze ref/
	(32)msb	(33)lsb	Freeze output
Setup 1	0	0	0
Setup 2	0	1	0
Setup 3	1	0	0
Setup 4	1	1	0
No speed change	0	0	1
Speed down	0	1	1
Speed up	1	0	1
Speed down	1	1	1

Catch-up/Slow-down is selected if the reference value is to be increased or reduced by a programmable percentage value set in parameter 219.

	Slow-down	Catch-up
Unchanged speed	0	0
Reduced by %-value	1	0
Increased by %-value	0	1
Reduced by %-value	1	1

Ramp 2 is selected if a change between ramp 1 (parameters 207-208) and ramp 2 (209-210) is desired. Logic '0' ramp 1, while logic '1' ramp 2.

Mains failure inverted is to be selected if parameter 407 *Mains failure* and/or parameter 408 *Quick discharge* is activated. Mains failure inverted is active in the logical '0' situation.



NB!:

The frequency converter can be totally damaged by repeating the Quick discharge function on the digital input with mains voltage connected to the drive.

Pulse reference is selected if a pulse sequence (speed) of 0 rpm is used, corresponding to Ref_{MIN}, parameter 204. The frequency is set in parameter 327, corresponding to Ref_{MAX}.

Parameter no.	Description	Display text	Max frequency to terminal
300	Terminal 16, input	(DIGITAL INPUT 16)	5 kHz.
301	Terminal 17, input	(DIGITAL INPUT 17)	5 kHz.
302	Terminal 18 Start, input	(DIGITAL INPUT 18)	5 kHz.
303	Terminal 19, input	(DIGITAL INPUT 19)	5 kHz.
304	Terminal 27, input	(DIGITAL INPUT 27)	5 kHz.
305	Terminal 29, input	(DIGITAL INPUT 29)	65 kHz.
306	Terminal 32, input	(DIGITAL INPUT 32)	5 kHz.
307	Terminal 33, input	(DIGITAL INPUT 33)	5 kHz.

★ = factory setting. () = display text [] = value for use in communication via serial communication port

Regarding **Value, Function** and **Description of choice**, please see table in section *Digital Input Functions* .

■ Analogue inputs

Analogue inputs	terminal no.	53(voltage)	54(voltage)	60(current)
	parameter	308	311	314
Value:				
No operation	(NO OPERATION)	[0]	[0]★	[0]
Reference	(REFERENCE)	[1] ★	[1]	[1] ★
Torque limit	(TORQUE LIMIT CTRL)	[3]	[2]	[3]
Thermistor	(THERMISTOR INPUT)	[4]	[3]	
KTY Thermistor	(KTY THERMISTOR)		[4]	
Speed limit	(SPEED LIMIT CTRL)		[15]	

Function:

Description of choice:

Analogue Input Functions

No operation Is selected when the signal connected to the terminal is disabled.

Reference Is selected to enable change of reference by means of an analogue reference signal. If other analogue inputs are connected, these are added up, taking account of their signs.

Torque limit Is used if the torque limit value set in parameter 221 is changed by means of an analogue signal.

Thermistor Is selected if a thermistor integrated in the motor for motor protection must stop the frequency converter in case of motor overtemperature. The cut-out value is > 3 kΩ.

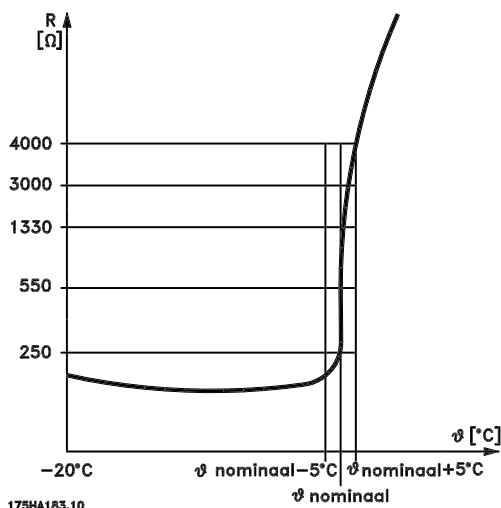

of the temperature and the motor windings. This is carried through by correcting the stator (R_s) and rotor (R_r) resistances as following:

- $R_s = R_s(20^\circ\text{C}) (1 + cu_alfa * (temperature_std_temperature))$
- $R_r = R_r(20^\circ\text{C}) (1 + cu_alfa * (temperature_std_temperature))$,

where

- $cu_alfa = 0.00393$ is copper temperature coefficient
- $std_temperature = 20^\circ\text{C}$ is standard temperature

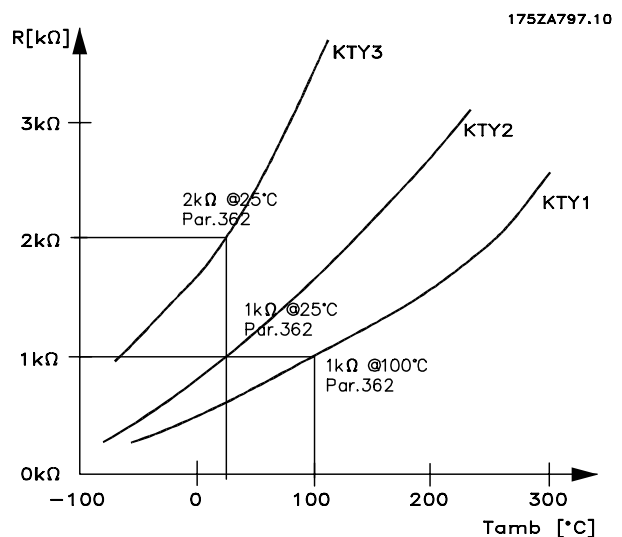

NB!:

If the temperature of the motor is utilized through a thermistor via the frequency converter, the following must be noted:

PELV is not complied with in case of short circuits between motorwinding and thermistor. In order to comply with PELV, the thermistor must be isolated.

KTY Sensor Is selected, when it is demanded to correct the Regulation model according to changes
★ = factory setting. () = display text [] = value for use in communication via serial communication port

If a motor features a thermal switch instead, this can also be connected to the input. Parameter

128 must be programmed for *Thermistor warning* [1] or *Thermistor trip* [2].

Speed limit is used if speed limit value set in Parameter 202 is changed by means of an analogue signal.

308 Terminal 53, analogue input voltage
(AI [V] 53 FUNCT.)

Value:

See the *Analogue Inputs* table.

Function:

Selection of the desired option on terminal 53. Scaling of input signal is selected in parameter 309 and 310.

Description of choice:

See the section *Analogue Input Functions*.

309 Terminal 53, min. scaling
(AI 53 SCALE LOW)

Value:

0.0 - 10.0 Volt ★ 0.0 Volt

Function:

This parameter is used for setting the analogue input scaling value that corresponds to the minimum reference value set in parameter 204.

Description of choice:

Set the desired voltage value.
 See also section *Handling of single references*.

310 Terminal 53, max. scaling
(AI 53 SCALE HIGH)

Value:

Parameter 309 - 10.0 Volt ★ 10.0 Volt

Function:

Is used for setting the scaling value that relates to the maximum reference value set in parameter 205.

Description of choice:

Set the desired voltage value.
 See also section *Handling of single references*.

311 Terminal 54, analogue input voltage
(AI [V] 54 FUNCT.)

Value:

See the *Analogue Inputs* table.

Function:

Selection of the desired option on terminal 54. Scaling of input signal is selected in parameter 312 and 313.

Description of choice:

See the section *Analogue Input Functions*.

312 Terminal 54, min. scaling
(AI 54 SCALE LOW)

Value:

0.0 - 10.0 Volt ★ 0.0 Volt

Function:

This parameter is used for setting the scaling value that corresponds to the minimum reference value set in parameter 204.

Description of choice:

Set the desired voltage value.
 See also section *Handling of single references*.

313 Terminal 54, max. scaling
(AI 54 SCALE HIGH)

Value:

Parameter 312 - 10.0 Volt ★ 10.0 Volt

Function:

This parameter is used for setting the scaling value that corresponds to the maximum reference value set in parameter 205.

Description of choice:

Set the desired voltage value.
 See also section *Handling of single references*.

314 Terminal 60, analogue input current
(AI [MA] 60 FUNCT)

Value:

See the *Analogue Inputs* table.

Function:

Selection of the desired option on terminal 60. Scaling of analogue current input signal is selected in parameter 315 and 316.

★ = factory setting. () = display text [] = value for use in communication via serial communication port

Description of choice:

See the section *Analogue Input Functions*.

315 Terminal 60, min. scaling

(AI 60 SCALE LOW)

Value:

0.0 - 20.0 mA ★ 4 mA

Function:

This parameter determines the value of the reference signal that is to correspond to the minimum reference value set in parameter 204. If the Time-out function of parameter 317 is used, the value must be set at >2 mA.

Description of choice:

Set the desired current value. See also section *Handling of single references*.

316 Terminal 60, max. scaling

(AI 60 SCALE HIGH)

Value:

Parameter 315 - 20.0 mA ★ 20.0 mA

Function:

This parameter sets the value of the reference signal that is to correspond to the maximum reference value set in parameter 205.

Description of choice:

Set the desired current value. See also section *Handling of single references*.

317 Time out

(LIVE ZERO TIME O)

Value:

0 - 99 sec. ★ 10 sec.

Function:

If the signal value of the reference signal connected to the input, terminal 60, falls below 50% of the value set in parameter 315 for a period longer than the time set in parameter 317, the function selected in parameter 318 will be activated.

Description of choice:

Set the desired time.

318 Function after time out

(LIVE ZERO FUNCT.)

Value:

★Off (OFF)	[0]
Freeze output speed (FREEZE OUTPUT SPEED)	[1]
Stop (STOP)	[2]
Jog (JOGGING)	[3]
Max. speed (MAX SPEED)	[4]
Stop and trip (STOP AND TRIP)	[5]

Function:

This parameter allows a choice of the function to be activated if the input signal on terminal 60 drops below 2 mA, provided parameter 315 has been set higher than 2 mA and that the time for time-out (parameter 317) has been exceeded.

If more time-outs occur at the same time the frequency converter will give the following priority to the time-out function:

1. Parameter 318 *Function after time out*
2. Parameter 346 *Function after encoder loss*
3. Parameter 514 *Bus time interval function*

Description of choice:

The output speed of the frequency converter can be:

- frozen at the present value
- overruled to stop
- overruled to jog speed
- overruled to max. speed
- overruled to stop with subsequent trip.

★ = factory setting. () = display text [] = value for use in communication via serial communication port

■ Analogue Outputs

Analogue outputs (terminal 42 and 45).

Analogue outputs are current outputs: 0/4 - 20 mA.

Common terminal (terminal 39) is the same terminal and electrical potential for analogue common and digital common connection.

Outputs	terminal no.	42	45
	parameter	319	321
Value:			
No function	(NO OPERATION)	[0]★	[0]★
0-100 Hz 0-20 mA	(0-100 Hz = 0-20 mA)	[1]	[1]
0-100 Hz 4-20 mA	(0-100 Hz = 4-20 mA)	[2]	[2]
Ref _{MIN} - Ref _{MAX} 0-20 mA	(REF MIN-MAX = 0-20 mA)	[3]	[3]
Ref _{MIN} - Ref _{MAX} 4-20 mA	(REF MIN-MAX = 4-20 mA)	[4]	[4]
0 - I _{MAX} 0-20 mA	(0-IMAX = 0-20 mA)	[7]	[7]
0 - I _{MAX} 4-20 mA	(0-IMAX = 4-20 mA)	[8]	[8]
0 - T _{LIM} 0-20 mA	(0-TLIM = 0-20 mA)	[9]	[9]
0 - T _{LIM} 4-20 mA	(0-TLIM = 4-20 mA)	[10]	[10]
0 - T _{NOM} 0-20 mA	(0-TNOM = 0-20 mA)	[11]	[11]
0 - T _{NOM} 4-20 mA	(0-TNOM = 4-20 mA)	[12]	[12]
0 - P _{NOM} 0-20 mA	(0-PNOM = 0-20 mA)	[13]	[13]
0 - P _{NOM} 4-20 mA	(0-PNOM = 4-20 mA)	[14]	[14]
0 - MAX SPEED 0-20 mA	(0-MAX SPD. = 0-20 mA)	[15]	[15]
0 - MAX SPEED 4-20 mA	(0-MAX SPD. = 4-20 mA)	[16]	[16]
+/-160% TORQ 0-20mA	(+/-160% TORQ= 0-20mA)	[17]	[17]
+/-160% TORQ 4-20mA	(+/-160% TORQ= 4-20mA)	[18]	[18]

319 Terminal 42 Output
(AO 42 FUNCTION)
Value:

See tabel in section *Analogue Outputs*.

Function:

The analogue output function generates an analogue current 0/4-20 mA.

Description of choice:

See description in section *Analogue output*.

321 Terminal 45, output
(AO 45 FUNCTION)
Value:

See table in section *Analogue outputs*.

Function:

The analogue output function generates an analogue current 0/4-20 mA.

Description of choice:

See description in section *Analogue Outputs*.

★ = factory setting. () = display text [] = value for use in communication via serial communication port

■ Digital and relay outputs

Digital outputs (Terminal 26 and 46, relay 01 and 04). Digital outputs are 0/24 V outputs Load : > 600Ω. Common terminal (terminal 39) is the same for analogue common and digital common. Relay 01 is placed on the power board in the frequency converter. Relay 04 is placed on the control board.

Outputs	terminal no.	01(relay)	04 (relay)	46	26
	parameter	323	326	341	355
Value:					
No function	(NO OPERATION)	[0]★	[0]★	[0]★	[0]★
Control ready	(CONTROL READY)	[1]	[1]	[1]	[1]
Ready signal	(UNIT READY)	[2]	[2]	[2]	[2]
Ready - remote control	(UNIT READY/REM CTRL)	[3]	[3]	[3]	[3]
Enable, no warning	(ENABLE/NO WARNING)	[4]	[4]	[4]	[4]
Running	(VLT RUNNING)	[5]	[5]	[5]	[5]
Running, no warning	(RUNNING/NO WARNING)	[6]	[6]	[6]	[6]
Running within range, no warning	(RUN IN RANGE/NO WARN)	[7]	[7]	[7]	[7]
Running at reference value, no warning	(RUN ON REF/NO WARN)	[8]	[8]	[8]	[8]
Fault	(ALARM)	[9]	[9]	[9]	[9]
Fault or warning	(ALARM OR WARNING)	[10]	[10]	[10]	[10]
Torque limit	(TORQUE LIMIT)	[11]	[11]	[11]	[11]
Out of current range	(OUT OF CURRENT RANGE)	[12]	[12]	[12]	[12]
Over I low	(ABOVE CURRENT,LOW)	[13]	[13]	[13]	[13]
Under I high	(BELOW CURRENT,HIGH)	[14]	[14]	[14]	[14]
Out of speed range	(OUT OF SPEED RANGE)	[15]	[15]	[15]	[15]
Over n low	(ABOVE SPEED LOW)	[16]	[16]	[16]	[16]
Under n high	(BELOW SPEED HIGH)	[17]	[17]	[17]	[17]
Thermal warning	(THERMAL WARNING)	[21]	[21]	[21]	[21]
Ready - no thermal warning	(READY & NOTHERM WARN)	[22]	[22]	[22]	[22]
Ready - remote control - no therm. warn.	(REM RDY & NO THERMWAR)	[23]	[23]	[23]	[23]
Ready - mains voltage within range	(RDY NO OVER/UNDERVOL)	[24]	[24]	[24]	[24]
Reversing	(REVERSE)	[25]	[25]	[25]	[25]
Bus ok	(BUS OK)	[26]	[26]	[26]	[26]
Torque limit and stop	(TORQUE LIMIT AND STOP)	[27]	[27]	[27]	[27]
Brake, no brake warning	(BRAKE NO BRAKE WARNING)	[28]	[28]	[28]	[28]
Brake ready, no fault	(BRAKE RDY (NO FAULT))	[29]	[29]	[29]	[29]
Brake fault	(BRAKE FAULT (IGBT))	[30]	[30]	[30]	[30]
Relay 123	(RELAY 123)	[31]	[31]	[31]	[31]
Mechanical brake control	(MECH. BRAKE CONTROL)	[32]	[32]	[32] ¹⁾	[32] ¹⁾
Control word bit 11/12	(CTRL WORD BIT 11/12)	[33]	[33]	[33]	[33]
Ref _{MIN} - Ref _{MAX} 0-50000 p	(REF MIN-MAX = 0-50000P)			[34]	[34]
0 - I _{MAX} 0-50000 p	(0-IMAX = 0-50000P)			[36]	[36]
0 - T _{LIM} 0-50000 p	(0-TLIM = 0-50000P)			[37]	[37]
0 - T _{NOM} 0-50000 p	(0-TNOM = 0-50000P)			[38]	[38]
0 - P _{NOM} 0-50000 p	(0-PNOM = 0-50000P)			[39]	[39]
0 - MAX SPEED 0-50000 p	(0-MAX SPD. = 0-50000P)			[40]	[40]
+/-160% TORQ 0-50000 p	(+/-160% TORQ= 0-50000P)			[41]	[41]

Programming

1) When mechanical brake control is selected, output 46 and 26 are inverted.

Function:
Description of choice:

Control ready, the frequency converter is ready for use; the control board receives supply voltage.

Ready signal, the frequency converter control board is receiving a supply signal and the frequency converter is ready for operation.

Ready, remote control, the frequency converter control board is receiving a supply signal and parameter 002 has been set to *remote control*.

★ = factory setting. () = display text [] = value for use in communication via serial communication port

Enable, no warning, the frequency converter is ready for use; no start or stop command has been given (start/disable). No warning.

Running, a start command has been given.

Running, no warning, the output speed is higher than the speed set in parameter 123. A start command has been given. No warning.

Runs in range, no warning, runs within the programmed current/speed ranges set in parameters 223-226.

Runs on reference, no warning, speed according to reference.

Fault, output is activated by alarm.

Fault or warning, the output is activated by alarm or warning.

Torque limit, the torque limit in parameter 221 has been exceeded.

Out of current range, the motor current is outside the range programmed in parameters 223 and 224.

Over I low, the motor current is higher than set in parameter 223.

Under I high, the motor current is lower than set in parameter 224.

Out of range speed, the output speed is outside the speed range programmed in parameters 225 and 226.

Over n low, the output speed is higher than the value set in parameter 225.

Under n high, the output speed is lower than the value set in parameter 226.

Thermal warning, above the temperature limit in either the motor, the frequency converter, the brake resistor or the thermistor.

Ready - no thermal warning, the frequency converter is ready for use, the control board receives supply voltage and there are no control signals on the inputs. No over-temperature.

Ready - remote control - no thermal warning, the frequency converter is ready for use and set at remote control, the control board receives supply voltage. No over-temperature.

Ready - mains voltage within range, the frequency converter is ready for use, the control board receives supply voltage and there are no control signals on the inputs. The mains voltage is within the permitted voltage range (see section *Technical Data*).

Reversing. Logic '1' = relay activated, 24 V DC on the output when CW rotation of the motor. Logic '0' = relay not activated, no signal on the output, when the CCW rotation of the motor.

Bus-ok, active communication (no time-out) via the serial communication port.

Torque limit and stop is used in connection with coasting stop (terminal 27), also in torque limit condition.

The signal is logic '0' when frequency converter has received a stop signal and is at the torque limit.

Brake, no brake warning, the brake is active and there are no warnings.

Brake ready, no fault, the brake is ready for operation and there are no faults.

Brake fault, the output is a logical "1" when the brake IGBT has short-circuited. This function is used to protect the frequency converter if there is a fault on the brake modules. The output/relay can be used to cut out the main voltage from the frequency converter.

Relay 123, if Fieldbus profile [0] has been selected in parameter 512, the relay is activated. If either OFF1, OFF2 or OFF3 (bit in the control word) is logic '1'.

Mechanical brake control, enables control of an external mechanical brake, see description in the section *Control of Mechanical Brake*.

Control word bits 11/12, relay controlled via bits 11/12 in serial control word. Bit 11 relates to relay 01 and bit 12 to relay 04. If parameter 514 *Bus time interval function* is active, relays 01 and 04 will be open state. See section on Serial communication in the Design Guide.

Ref_{MIN} - Ref_{MAX}, an output signal proportional to the reference value in the interval Ref_{MIN} - Ref_{MAX} (parameters 204/205) is obtained.

0 - I_{VLT,MAX}, an output signal proportional to the output current in the interval 0 - I_{VLT,MAX} is obtained. I_{VLT,MAX} depends on the settings in parameter 101 and 103 and can be seen from the *Technical data* (I_{VLT,MAX} (60 s)).

0 - T_{LIM}, an output proportional to the output torque in the interval 0 - T_{LIM} (parameter 221) is obtained.

0 - T_{NOM}, an output signal proportional to the output torque of the motor.

0 - P_{NOM}, 0 - P_{NOM}, an output signal proportional to the rated motor output is obtained.

0 - MAX SPEED, 0 - MAX SPD., an output signal proportional to the rated motor speed is obtained.

+/-160% TORQ, +/-160% TORQ, an output signal proportional to 160% torque is obtained.

★ = factory setting. () = display text [] = value for use in communication via serial communication port

**323 Relay 01, output
(RELAY 1-3 FUNCT.)**

Value:

See table in section *Digital Outputs*.

Function:

This output activates a two-way relay. Relay information 01 can be used for bringing status and warnings. The relay is activated when the conditions for the relevant data values have been fulfilled. Activation/deactivation can be delayed in parameter 324/325.

Description of choice:

See description in section *Digital and relay outputs*. Connections - see the drawing below.

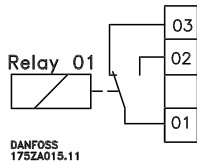

Max. terminal load (AC) on 1-3, 1-2, power card	240 V AC, 2 A, 60 VA
Max. terminal load on 1-3, 1-2, power card	50 V DC, 2 A
Min. terminal load on 1-3, 1-2, power card	24 V DC 10 mA, 24 V AC 100 mA

**324 Relay 01, ON delay
(RELAY 1-3 ON DL)**

Value:

0.00 - 600.00. ★ 0.00 sec.

Function:

This parameter allows a delay of the cut-in time of relay 01 (terminals 01-02).

Description of choice:

Enter the desired value (can be set at intervals of 0.02 sec.).

**325 Relay 01, OFF delay
(RELAY 1-3 OFF DL)**

Value:

0.00 - 600.00 ★ 0.00 sec.

Function:

This parameter makes it possible to delay the cut-out time of relay 01 (terminals 01-03).

Description of choice:

Enter the desired value (can be set at intervals of 0.02 sec.).

**326 Relay 04, output
(RELAY 4-5 FUNCT.)**

Value:

See description of parameter 319.

Function:

This output activates a make relay. Relay switch 04 can be used for bringing status and warnings. The relay is activated when the conditions for the relevant data values have been fulfilled.

Description of choice:

See description in section *Digital and relay outputs*. Connections - see the below drawing.

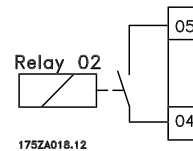

Max. terminal load (AC) on 4-5, control card	50 V AC, 1 A, 60 VA
Max. terminal load (DC) on 4-5, control card	75 V DC, 0.1 A, 30 W
Max. terminal load (DC) on 4-5, control card for UL/cUL applications	30 V AC, 1 A / 42.5 V DC, 1A

**327 Pulse reference, max. frequency
(PULSE REF MAX)**

Value:

100 - 65000 Hz at terminal 29 ★ 5000 Hz

Function:

In this parameter, the signal value is set that corresponds to the maximum reference value set in parameter 205.

Description of choice:

Set the desired pulse reference.

**329 Encoder feedback pulse/rev.
(ENCODER PULSES)**

Value:

512 pulses /rev. (512) [512]
★1024 pulses /rev. (1024) [1024]

Programming

★ = factory setting. () = display text [] = value for use in communication via serial communication port

2048 pulses/rev. (2048) [2048]
 4096 pulses/rev. (4096) [4096]

This value can also be set between 500 - 10.000 ppr.
 The number of pulses per revolution can be set between 500 - 10.000 ppr.

Function:

Set the encoder pulses per revolution on the motor shaft.
 This parameter is disabled in Open loop function. (Parameter 100 = *SPEED OPEN LOOP*)

Description of choice:

Read the correct value from the encoder. Pay attention to the speed limitation (rpm) for a given number of pulses/rpm, see the drawing below:

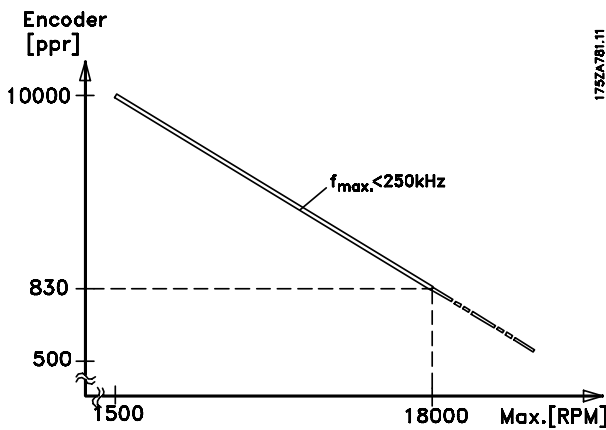

The encoder used is a quadruple 5 volt type.
 Max input frequency: 250 kHz.
 See sections *Feedback Systems*, *General Technical Data* and *Control Board Encoder*.

341 Terminal 46, digital output (DO 46 FUNCTION)

Value:

See table in section *Digital and relay outputs*.

Function:

The output shifts from 0 V to 24 V when the output is true.

Description of choice:

See description in section *Digital relay outputs*.

342 Terminal 46, output, pulse scaling (DO 46 MAX PULS)

Value:

1 - 50000 Hz ★ 5000 Hz

Function:

This parameter allows scaling of the pulse output signal.

Description of choice:

Set the desired value.

350 Encoder monitoring (ENCODER MONITOR)

Value:

★0 (OFF) [0]
 1 (OPTION & STANDARD) [1]

Function:

If failure on encoder lines occur selection of this parameter can generate an alarm (alarm 44) for avoiding unintended start of the motor.
 Encoder feedback pulse/rev function is disabled in open loop (parameter 100 = *Speed open Loop*).

Description of choice:

Select ON when the encoder cables must be supervised.

351 Encoder direction (ENCODER DIR.)

Value:

★0 (NORMAL CW) [0]
 1 (INVERSE CCW) [1]

Function:

Change the detected encoder direction (revolution) without changing the wires to the encoder.
 Encoder monitoring function is disabled in open loop (parameter 100 = *Speed open loop*).

Description of choice:

Select *NORMAL CW* when A channel is 90° (electrical degrees) before channel B by clockwise rotation of the encoder shaft. Select *INVERSE CCW* when A channel is 90° (electrical degrees) after channel B by counter clockwise rotation of the encoder shaft.

★ = factory setting. () = display text [] = value for use in communication via serial communication port

355 Terminal 26, digital output

(DO 26 FUNCTION)

Value:

See table in section *Digital and relay outputs*.

Function:

The digital outputs shift from 0 V to 24 V when the output is true.

Description of choice:

See description in section *Digital relay outputs*.

356 Terminal 26, output, pulse scaling

(DO 26 FUNCTION)

Value:

1 - 50000 Hz ★ 5000 Hz

Function:

This parameter allows scaling of the pulse output signal.

Description of choice:

Set the desired value.

357 Terminal 42, Output minimum scaling

(OUT 42 SCAL MIN)

359 Terminal 45, Output minimum scaling

(OUT 45 SCAL MIN)

Value:

000 - 100% ★ 0%

Function:

These parameters are to scale the minimum output of the selected analogue signal on terminals 42 and 45.

Description of choice:

The minimum value is to be scaled as a percentage of the maximum signal value, i.e. 0mA (or 0 Hz) is desired at 25% of the maximum output value, and then 25% is programmed.
The value can never be higher than the corresponding setting of *Output maximum scaling* if this value is below 100%.

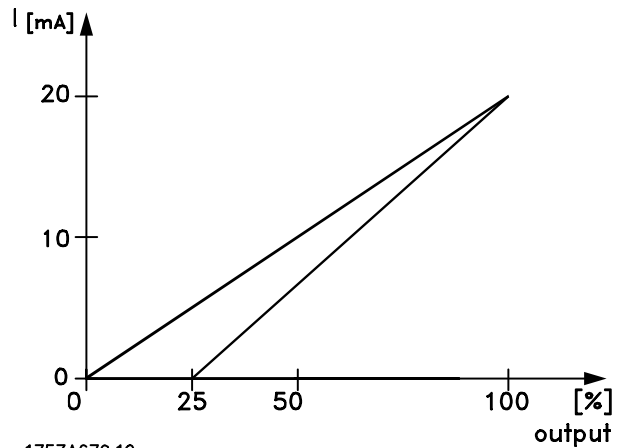

175ZA679.10

358 Terminal 42, Output maximum scaling

(OUT 42 SCAL MAX)

360 Terminal 45, Output maximum scaling

(OUT 45 SCAL MAX)

Value:

000 - 500% ★ 100%

Function:

These parameters are to scale the maximum output of the selected analogue signal on terminals 42 and 45.

Description of choice:

Set the value to the desired maximum value of the current signal output.

Maximum value:

The output can be scaled to give a lower current than 20 mA at full scale or 20 mA at an output below 100% of the maximum signal value. If 20 mA is the desired output current at a value between 0 - 100% of the full-scale output, program the percentage value in the parameter, i.e. 50% = 20 mA. If a current between 4 and 20 mA is desired at maximum output (100%), the percentage value to program in the drive is calculated as:

$$0 \text{ mA} / \text{desired maximum current} * 100\% ,$$

$$\text{i.e. } 0 \text{ mA} = \frac{20}{10} * 100 = 200\%$$

Programming

★ = factory setting. () = display text [] = value for use in communication via serial communication port

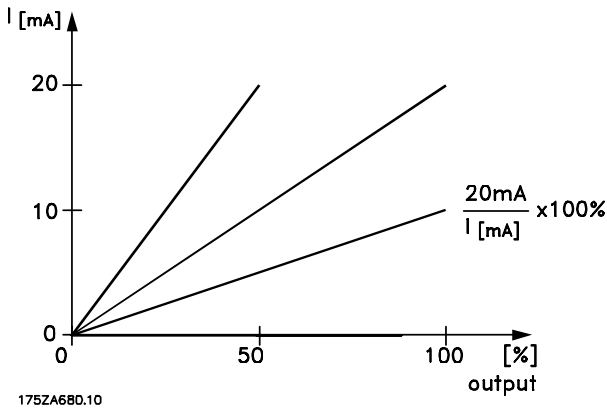

361 Max Tracking Error

(MAX TRACKING ERR)

Value:

000 - 999 rpm ★ OFF (0 rpm)

Function:

Parameter 361 measures the deviation between reference speed (calculated speed) and actual mechanical shaft speed from feedback device (incremental encoder).

Exceeding the value of parameter 361 will generate Alarm 48 and cause a trip.

Description of choice:

Set the desired value. 0 speed will switch off the function.

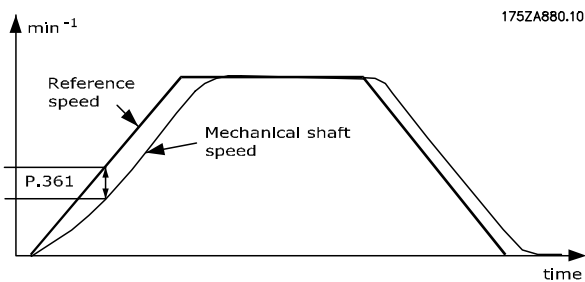

362 KTY Sensor Type

(KTY TYPE)

Value:

- ★KTY Sensor 1 (KTY1) [0]
- KTY Sensor 2 (KTY2) [1]
- KTY Sensor 3 (KTY3) [2]

Function:

Choice of the KTY sensor for temperature compensation.

Description of choice:

The KTY sensor must be selected and enabled in parameter 311 (Terminal 54, Analogue input).

★ = factory setting. () = display text [] = value for use in communication via serial communication port

KTY Sensor 1 selected: 1 kΩ @100°C

KTY Sensor 2 selected: 1 kΩ @25°C

KTY Sensor 3 selected: 1 kΩ @25°C

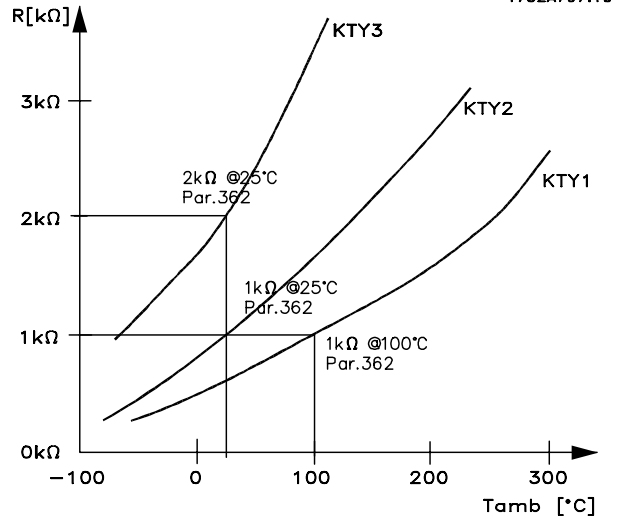

NB!:

This parameter can only be changed, when the motor is stopped.

■ Special Functions
■ Introduction

The purpose of the special functions is to select and adjust special functions for over voltage control, brake resistor and power, brake check, speed controlling parameters, LC filter, mains failure functions and flying start.

PNU #	Parameter description	Factory setting	Range	Changes during operation	4-Setup	Conversion index	Data type
400	Brake function/overvoltage control	Off		Yes	No	0	5
401	Brake resistor, ohm	Depends on the unit		Yes	No	-1	6
402	Brake power limit, kW	Depends on the unit		Yes	No	2	6
403	Power monitoring	Warning		Yes	No	0	5
404	Brake check	Off		Yes	No	0	5
405	Reset function	Manual reset		Yes	Yes	0	5
406	Automatic restart time	5 sec.	0 - 10 sec.	Yes	Yes	0	5
409	Trip delay torque	5 sec.	0 - 60 sec.				
417	Speed PID proportional gain	0.015	0.000 - 5.000	Yes	Yes	-3	6
418	Speed PID integration time	200 ms	2.00 - 20.000 ms	Yes	Yes	-4	7
421	Speed PID low-pass filter	5/20	1-500 ms	Yes	Yes	-4	6
445	Flying start	Disable		Yes	Yes	0	5
458	LC-filter connected	No	0-1	No	Yes	0	5
459	Capacity LC-filter	2 µF	0.1-100 µF	No	Yes	-1	6
460	Inductance LC-filter	7 mH	0.1-100 mH	No	Yes	-1	6
462	Saturation brake	Off	0-100%	Yes	Yes	0	6
463	AEO Cos Phi	0.91 = OFF	0.50-0.91	Yes	Yes	-2	S16
470	Adaptive Gain Scale	100%	20%-500%	Yes	Yes	0	U16
471	Adaptive Gain min speed	50 RPM	0-1500 RPM	Yes	Yes	67	U16
472	Adaptive Gain max speed	50 RPM	0-1500 RPM	Yes	Yes	67	U16

★ = factory setting. () = display text [] = value for use in communication via serial communication port

400 Brake function/overvoltage control

(BRAKE FUNCTION)

Value:

★Off (OFF)	[0]
Resistor brake (RESISTOR)	[1]
Overvoltage control (OVERVOLTAGE CONTROL)	[2]
Overvoltage control and stop (OVERVOLT CTRL. & STOP)	[3]

Function:

The factory setting is *Off* [0] for VLT 5001-5062 380-500 V and 5001-5027 200-240 V. For VLT 5075-5250 380-500 V and 5032-5052 200-240 V the factory setting is *Overvoltage control* [2]. *Resistor brake* [1] is used for programming the frequency converter for connection of a brake resistor. The connection of a brake resistor allows a higher intermediate circuit voltage during braking (generating operation). The *Resistor brake* [1] function is only active in units with an integral dynamic brake (SB and EB units).

Overvoltage control (excl. brake resistor) can be selected as an alternative. This function is active for all units (ST, SB and EB).

The function ensures that a trip can be avoided if the intermediate circuit voltage increases. This is done by increasing the output frequency to limit the voltage from the intermediate circuit. This is a very useful function, e.g. if the ramp-down time is too short, since tripping of the frequency converter is avoided. In this situation, the ramp-down time is extended.



NB!:

Please note that the ramp-down time is extended in the case of overvoltage control, which in some applications may not be appropriate.

Description of choice:

Select *Resistor brake* [1] if a brake resistor is part of the system.
 Select *Overvoltage control* [2] if the overvoltage control function is required in all cases - also if stop is pressed. The frequency converter will stop in the case of a stop command when the overvoltage control is active, but not necessarily follow the deceleration ramp.
 Select *Overvoltage control and stop* [3] if the overvoltage control function is not required during ramp-down after stop has been pressed.



Warning: If *Overvoltage control* [2] is used at the same time as the supply voltage to the frequency converter is close to or above the maximum limit, there is a risk that the motor frequency will increase and that, consequently, the frequency converter will not stop the motor when stop is pressed. If the supply voltage is higher than 264 V for 200-240 V units or higher than 550 V for 380-500 V units, *Overvoltage control and stop*[3] should be selected so that the motor can be stopped.

401 Brake resistor, ohm

(BRAKE RES. (OHM))

Value:

ohm ★ Depends on the unit

Function:

This parameter gives the ohmic value of the brake resistor. This value is used for monitoring the power to the brake resistor provided this function has been selected in parameter 403.

Description of choice:

Set the present resistor value.

402 Brake power limit, kW

(BR.POWER. LIM.KW)

Value:

kW ★ Depends on the unit

Function:

This parameter gives the monitoring limit of the brake power transmitted to the resistor.

Description of choice:

The monitoring limit is determined as a product of the maximum duty cycle (120 sec.) that will occur and the maximum power of the brake resistor at that duty cycle according to the following formula.

For 200 - 240 V units: $P = \frac{397^2 \times t}{R \times 120}$

For 380 - 500 V units: $P = \frac{822^2 \times t}{R \times 120}$

403 Power monitoring

(POWER MONITORING)

Value:

Off (OFF)	[0]
★Warning (WARNING)	[1]
Trip (TRIP)	[2]

★ = factory setting. () = display text [] = value for use in communication via serial communication port

Function:

This parameter allows monitoring of the power transmitted to the brake resistor. The power is calculated on the basis of the resistor ohm value (parameter 401), the intermediate circuit voltage and the resistor running time. If the power transmitted over 120 sec. exceeds 100% of the monitoring limit (parameter 402) and *Warning* [1] has been selected, a warning will come up on the display. The warning will disappear if the power goes below 80%. If the calculated power exceeds 100% of the monitoring limit and *Trip* [2] has been selected in parameter 403 *Power monitoring*, the frequency converter will trip and give an alarm. If power monitoring has been selected *Off* [0] or *Warning* [1], the brake function will remain active, even if the monitoring limit has been exceeded. This may lead to thermal overload of the resistor. It is also possible to have a warning via the relay/digital outputs. The typical measuring accuracy of the power monitoring depends on the accuracy of the resistor ohmic value (better than $\pm 20\%$).

Description of choice:

Select whether this function is to be active (*Warning/Alarm*) or inactive (*Off*).

404 Brake check (BRAKE TEST)

Value:

★Off (OFF)	[0]
Warning (WARNING)	[1]
Trip (TRIP)	[2]

Function:

In this parameter a testing and monitoring function can be integrated which will give a warning or an alarm. On power-up it will be tested whether the brake resistor is disconnected. The test of whether the brake resistor is disconnected is carried out during braking, while the test of whether the IGBT is disconnected is carried out when there is no braking. A warning or trip disconnects the brake function.

The testing sequence is as follows:

1. If the intermediate circuit voltage is higher than the brake starting voltage, discontinue the brake check.
2. If the intermediate circuit voltage is unstable, discontinue the brake check.
3. Carry out a brake test.
4. If the intermediate circuit voltage after the brake test is lower than the starting voltage, discontinue the brake check.
5. If the intermediate circuit voltage is unstable, discontinue the brake check.

★ = factory setting. () = display text [] = value for use in communication via serial communication port

6. If the braking power is higher than 100%, discontinue the brake check.
7. If the intermediate circuit voltage is higher than the intermediate circuit voltage -2% before the brake test, discontinue the brake check and give off a warning or alarm.
8. Brake check OK.

Description of choice:

If *Off* [0] is selected, this function will still monitor whether the brake resistor and the brake IGBT short-circuit during operation, in which case it will give off a warning. If *Warning* [1] is selected, the brake resistor and brake IGBT will be monitored with respect to short-circuiting. In addition, on power-up it will be checked whether the brake resistor has been disconnected.



NB!:

A warning in connection with *Off* [0] or *Warning* [1] can only be removed by disconnecting the mains supply and turning it back on, provided the fault has been corrected. Please note that in connection with *Off* [0] or *Warning* [1] the frequency converter will continue even if a fault has been found.

In the case of *Trip* [2], the frequency converter will cut out while giving an alarm (trip locked) if the brake resistor has short-circuited or been disconnected or if the brake IGBT has short-circuited.

405 Reset function (RESET MODE) (RESET MODE)

Value:

★Manual reset (MANUAL RESET)	[0]
Automatic reset x 1 (AUTOMATIC X 1)	[1]
Automatic reset x 2 (AUTOMATIC X 2)	[2]
Automatic reset x 3 (AUTOMATIC X 3)	[3]
Automatic reset x 4 (AUTOMATIC X 4)	[4]
Automatic reset x 5 (AUTOMATIC X 5)	[5]
Automatic reset x 6 (AUTOMATIC X 6)	[6]
Automatic reset x 7 (AUTOMATIC X 7)	[7]
Automatic reset x 8 (AUTOMATIC X 8)	[8]
Automatic reset x 9 (AUTOMATIC X 9)	[9]
Automatic reset x 10 (AUTOMATIC X 10)	[10]
Reset at power up (RESET POWER UP)	[11]

Function:

This parameter makes it possible to select the reset function desired after tripping. After reset, the frequency converter can be restarted.

Description of choice:

If *Manual reset* [0] is selected, reset must be effected via the [RESET] key or via the digital inputs. If the frequency converter is to carry out an automatic reset (1-10 times) after tripping, select data value [1]-[10].

If *Reset at power-up* [11] is selected, the frequency converter will carry out a reset if there has been a fault in connection with the mains failure.



NB!:

The internal AUTOMATIC RESET counter is reset 10 minutes after the first AUTOMATIC RESET has occurred.



Warning: The motor may start without warning.

406 Automatic restart time (AUT RESTART TIME)

Value:

0 - 10 sec. ★ 5 sec.

Function:

This parameter allows setting of the time from tripping until the automatic reset function begins. It is assumed that automatic reset has been selected in parameter 405.

Description of choice:

Set the desired time.

407 Mains failure (MAINS FAILURE)

Value:

★No function (NO FUNCTION)	[0]
Controlled ramp-down (CONTROL RAMP DOWN)	[1]
Controlled ramp-down and trip (CTRL. RAMP DOWN-TRIP)	[2]
Coasting (COASTING)	[3]
Kinetic back-up (KINETIC BACKUP)	[4]
Kinetic back-up and trip (KINETIC BACKUP-TRIP)	[5]

Function:

Using the mains failure function, it is possible to ramp down the load to 0 speed if the mains supply to the frequency converter fails.

In parameter 450 *Mains voltage during mains fault*, the voltage limit must be set at which the *Mains fault* function is to be active.

★ = factory setting. () = display text [] = value for use in communication via serial communication port

This function can also be activated by selecting *Mains failure inverted* on a digital input.

When *Kinetic back-up* [4] and *Kinetic back-up and trip* [5] is selected, the ramp function in parameter 206-212 is deactivated.

Description of choice:

Select *No function* [0] if this function is not required. If *Controlled ramp-down* [1] is selected, the motor will ramp via the quick-stop ramp set in parameter 212. If the supply voltage is re-established during ramp-down, the frequency converter will start up again. If *Controlled ramp-down and trip* [2] is selected, the motor will ramp via the quick-stop ramp set in parameter 212.

At 0 speed the frequency converter will trip (ALARM 36, mains failure). If the supply voltage is re-established during ramp-down, the frequency converter will continue the quick-stop ramp and trip. If *Coasting* [3] is selected, the frequency converter will turn off the inverters and the motor will start coasting.

Parameter 445 *Flying motor* must be active, so that if the supply voltage is re-established, the frequency converter will be able to catch the motor and start up again.

If *Kinetic back-up* [4] is selected, the frequency converter will try to utilise the energy from the load to maintain a constant intermediate circuit voltage. If the supply voltage is re-established, the frequency converter will start up again.

If *kinetic back-up and trip* [5] is selected, the frequency converter will utilise the energy from the load to maintain a constant intermediate circuit voltage. Selecting kinetic back-up and trip ensures also kinetic back-up even if the start signal is removed. If the supply voltage is re-established, the frequency converter will run a normal stop and trip at 0 RPM.

409 Trip delay torque (TRIP DELAY TORQ.)

Value:

0 - 60 sec. (OFF) ★ OFF

Function:

When the frequency converter registers that the output torque has increased up to the torque limits (parameters 221 and 222) in the set time, cutting out is effected when that time has passed.

Description of choice:

Select how long the frequency converter is to be able to run at the torque limit before cutting out. 60

sec. = OFF means that the time is infinite; however, the thermal monitoring will still be active.

417 Speed PID proportional gain (SPEED PROP GAIN)

Value:
0.000 (OFF) - 0.150 ★ 0.015

Function:
Speed Proportional gain indicates how many times the error (deviation between the feedback signal and the set-point) is to be amplified. Used together with *Speed control, closed loop* and *Speed control, open loop* (parameter 100).

Description of choice:
Quick control is obtained at high amplification, but if the amplification is too high, the process may become unstable in the case of overshoot.

418 Speed PID integral time (SPEED INT. TIME)

Value:
2.00 - 19.999.99 ms (20.000 = OFF) ★ 200 ms

Function:
Speed integral time determines how long time the internal PID controller takes to correct the error. The greater error, the quicker the gain increases. The integral time results in a delay of the signal and therefore a dampening effect. Used together with *Speed control, closed loop* and *Speed control, open loop*(parameter 100).

Description of choice:
Quick control is obtained through a short integral time. However, if this time is too short, it can make the process unstable. If the integral time is long, major deviations from the required reference may occur, since the process regulator will take long to regulate if an error has occurred.

421 SPEED FILT. TIME

Value:
1-500 ms ★ CL: 5 ms / OP: 20 ms

Function:
Oscillations on the feedback signal are dampened by a lowpass filter and the resolution on speed

★ = factory setting. () = display text [] = value for use in communication via serial communication port

measurement is increased. This is necessary for the Flux Vector control to function properly. The *Speed Filter Time* is used with *Speed Control, Closed Loop*.

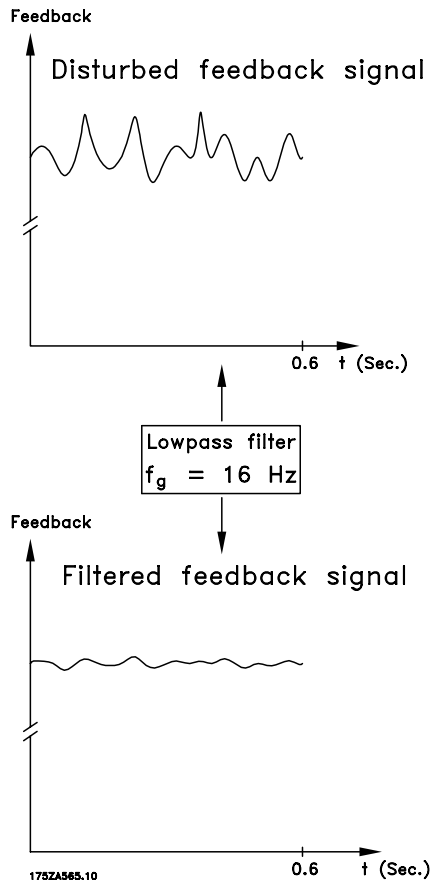

Description of choice:

If a time constant (τ) eg. of 10 ms is programmed, the cut-off frequency for the lowpass filter will be $1/0.01 = 100 \text{ RAD/sec.}$, corresponding to $(100/2 \times \pi) = 16.0 \text{ Hz}$. This means that the PI regulator will only regulate a feedback signal that varies by a frequency of less than 16.0 Hz. If the feedback signal varies by a higher frequency than 16.0 Hz, the PI regulator will not react.

445 Flying start (FLYING START)

Value:
★ Off (DISABLE) [0]
On (ENABLE) [1]

Function:
This function makes it possible to catch spinning motor, which is spinning freely because of a mains drop-out.

Programming

Description of choice:

Select *Disable* if this function is not required. Select *Enable* if the frequency converter is to be able to 'catch' and control a spinning motor.

450 Mains voltage at mains fault (MAINS FAIL VOLT.)

Value:

180-240 V for 200-240 V units ★ 180
342-500 V for 380-500 V units ★ 342

Function:

Set the voltage level at which parameter 407 *Mains fault* is to be activated. The voltage level for activating the mains fault functions must be lower than the rated mains voltage supplied to the frequency converter. As a rule of thumb, parameter 450 can be set to 10% below the rated mains voltage.

Description of choice:

Set the level for activating mains fault functions.



NB!:

If this value is set at too high a level, the mains fault function set in parameter 407 can be activated, even if the mains voltage is present.

458 LC-Filter connected (LC-FILTER ON)

Value:

On (ON) [0]
★ Off (OFF) [1]

Function:

Enables LC-filter compensation in the control system. Voltage drop by the LC-filter is not compensated.

Description of choice:

Enable or disable compensation for LC-filter on VLT output.

459 Capacity LC-Filter (CAP. LC-FILTER)

Value:

0.1-100 µF ★ 2 µF

Function:

Compensation function of the LC-filter requires the per phase equivalent star connected capacitance of the filter (3 times the capacity between two phases when capacitance is 'Delta' connection).

★ = factory setting. () = display text [] = value for use in communication via serial communication port

Description of choice:

Sets the LC-filter capacitance value.

460 Inductance LC-Filter (INDUCT. LC-FILTER)

Value:

0.1-100 mH ★ 7 mH

Function:

Compensation function of the LC-filter requires the per phase inductance of the filter.

Description of choice:

Sets the LC-filter inductance value.

462 Saturation brake (SATURATION BRAKE)

Value:

000 (OFF) - 100 % ★ OFF

Function:

Is selected to improve braking without using a brake resistor. This parameter controls an overmagnetization of the motor when running with a generative load. This function can improve the OVC-function. Increasing the electrical losses in the motor allows the OVC function to increase the braking torque without exceeding the over voltage limit. Please note that *Saturation brake* is not as effective as *Resistor brake*.

Description of choice:

Setting *Saturation brake* to 100% allows 150% magnetisation current when running with a generative load.

463 AEO Cos Phi (AEO COS PHI)

Value:

0.50-0.91 ★ 0.91 = OFF

Function:

CosPhi is usually a part of the nameplate on a motor. It expresses the efficiency of the motor and is here used to adjust motor-currents to give the most energy-efficient use.

Note: The use of AEO can reduce the dynamic performance significantly and should not be used on cranes, lifts, hoists, etc.

470 Adaptive Gain Scale**(ADAPTIVE GAIN)****Value:**20%-500% ★ 100%**Function:**

In many applications there is a need for having a different tuning of the speed controller depending on motor-speed; a high gain at low speeds (precise) and a lower gain at high speed (smooth). This Parameter defines a scaling of the proportional gain of the speed controller (Par. 417) at low speed..

471 Adaptive Gain Min. Speed**(AG MIN SPEED)****Value:**0-1500 RPM ★ 50 RPM**Function:**

In many applications there is a need for having a different turning of the speed controller depending on motor-speed; a high gain at low speeds (precise) and a lower gain at high speed (smooth). This Parameter defines the minimum speed of the speed range where adaptive gain scale is faded towards 100% of the value entered in Parameter 417.

472 Adaptive Gain Max. Speed**(AG MAX SPEED)****Value:**0-1500 RPM ★ 50 RPM**Function:**

In many applications there is a need for having a different tuning of the speed controller depending on motor-speed; a high gain at low speeds (precise) and a lower gain at high speed (smooth). This Parameter defines the maximum speed of the speed range where adaptive gain scale is faded towards 100% of the value entered in Parameter 417.

■ Serial communication
■ Introduction

The purpose of the serial communication parameters is to select and adjust parameters in conjunction with RS 485 field bus. See wiring diagram 'Bus connection' in the installation section.

PNU #	Parameter description	Factory setting	Range	Changes during operation	4-Setup	Conversion index	Data type
500	Address	1	1 - 126	Yes	No	0	6
501	Baudrate	9600 Baud		Yes	No	0	5
502	Coasting	Logic or		Yes	Yes	0	5
503	Quick-stop	Logic or		Yes	Yes	0	5
504	DC-brake	Logic or		Yes	Yes	0	5
505	Start	Logic or		Yes	Yes	0	5
506	Reversing	Digital input		Yes	Yes	0	5
507	Selection of setup	Logic or		Yes	Yes	0	5
508	Selection of speed	Logic or		Yes	Yes	0	5
509	Bus jog 1	200 rpm	0.0 - parameter 202	Yes	Yes	-1	6
510	Bus jog 2	200 rpm	0.0 - parameter 202	Yes	Yes	-1	6
512	Telegram profile	FC Drive		No	Yes	0	5
513	Bus time interval	1 sec.	1 - 99 s	Yes	Yes	0	5
514	Bus time interval function	Off		Yes	Yes	0	5
515	Data read-out: Reference %			No	No	-1	3
516	Data read-out: Reference unit			No	No	-3	4
518	Data read-out: Frequency			No	No	-1	6
520	Data read-out: Current			No	No	-2	7
521	Data read-out: Torque			No	No	-1	3
522	Data read-out: Power, kW			No	No	-1	7
523	Data read-out: Power, HP			No	No	-2	7
524	Data read-out: Motor voltage			No	No	-1	6
525	Data read-out: DC link voltage			No	No	0	6
526	Data read-out: Motor temp.			No	No	0	5
527	Data read-out: VLT temp.			No	No	0	5
528	Data read-out: Digital input			No	No	0	5
529	Data read-out: Terminal 53, analogue input			No	No	-2	3
530	Data read-out: Terminal 54, analogue input			No	No	-2	3
531	Data read-out: Terminal 60, analogue input			No	No	-5	3
532	Data read-out: Pulse reference			No	No	-1	7
533	Data read-out: External reference %			No	No	-1	3
534	Data read-out: Status word, binary			No	No	0	6
535	Data read-out: Brake power/2 min.			No	No	2	6
536	Data read-out: Brake power/sec.			No	No	2	6
537	Data read-out: Heat sink temperature			No	No	0	5
538	Data read-out: Alarm word, binary			No	No	0	7
539	Data read-out: VLT control word, binary			No	No	0	6
540	Data read-out: Warning word, 1			No	No	0	7
541	Data read-out: Extended status word			No	No	0	7
557	Data read-out: Motor RPM			No	No	0	4
558	Data read-out: Motor RPM x scaling			No	No	-2	4

★ = factory setting. () = display text [] = value for use in communication via serial communication port

500 Address
(BUS ADDRESS)

Value:
1 - 126 ☆ 1

Function:
This parameter allows specification of the address of each frequency converter. This feature is used in connection with PLC/PC connection.

Description of choice:
The individual frequency converters can be given an address between 1 and 126. The address 0 is used if a master (PLC or PC) wishes to send a telegram that is to be received by all frequency converters connected to the serial communication port at the same time. In this case, the frequency converter will not acknowledge receipt. If the number of units connected (frequency converters + master) exceeds 31, a repeater is required. Parameter 500 cannot be selected via the serial communication port.

501 Baudrate
(BAUDRATE)

Value:
300 Baud (300 BAUD) [0]
600 Baud (600 BAUD) [1]
1200 Baud (1200 BAUD) [2]
2400 Baud (2400 BAUD) [3]
4800 Baud (4800 BAUD) [4]
☆9600 Baud (9600 BAUD) [5]
19200 (19200 BAUD) [6]

Function:
This parameter is for programming the speed at which data is to be transmitted via the serial connection. Baud rate is defined as the number of bits transferred per second.

Description of choice:
The transmission speed of the frequency converter is to be set at a value that corresponds to the transmission speed of the PLC/PC. Parameter 501 cannot be selected via the serial port, RS 485. The data transmission time proper, which is determined by the set baud rate, is only part of the total communication time.

502 Coasting
(COASTING SELECT)

503 Quick-stop
(Q STOP SELECT)

504 DC-brake
(DC BRAKE SELECT)

505 Start
(START SELECT)

507 Selection of Setup
(SETUP SELECT)

508 Selection of speed
(PRES.REF. SELECT)

Value:
Digital input (DIGITAL INPUT) [0]
Bus (SERIAL PORT) [1]
Logic and (LOGIC AND) [2]
☆Logic or (LOGIC OR) [3]

Function:
Parameters 502-508 allow a choice between controlling the frequency converter via the terminals (digital input) and/or via the bus. If *Logic and or Bus* is selected, the command in question can only be activated if transmitted via the serial communication port. In the case of *Logic and*, the command must additionally be activated via one of the digital inputs.

Description of choice:
Digital input [0] is selected if the control command in question is only to be activated via a digital input. *Bus* [1] is selected if the control command in question is only to be activated via a bit in the control word (serial communication). *Logic and* [2] is selected if the control command in question is only to be activated when a signal is transmitted (active signal = 1) via both a control word and a digital input.

Digital input 505-508	Bus	Control command
0	0	0
0	1	0
1	0	0
1	1	1

Logic or [3] is selected if the control command in question is to be activated when a signal is given (active signal = 1) either via a control word or via a digital input.

Programming

☆ = factory setting. () = display text [] = value for use in communication via serial communication port

Digital input 505-508	Bus	Control command
0	0	0
0	1	1
1	0	1
1	1	1



NB!:

Parameters 502-504 deal with stop functions - see examples regarding 502 (coasting) below. Active stop command "0".

Parameter 502 = *Logic and*

Digital input	Bus	Control command
0	0	1 Coasting
0	1	0 Motor running
1	0	0 Motor running
1	1	0 Motor running

Parameter 502 = *Logic or*

Digital input	Bus	Control command
0	0	1 Coasting
0	1	1 Motor running
1	0	1 Motor running
1	1	0 Motor running

506 Reversing

(REVERSING SELECT)

Value:

★Digital input (DIGITAL INPUT)	[0]
Bus (SERIAL PORT)	[1]
Logic and (LOGIC AND)	[2]
Logic or (LOGIC OR)	[3]

Function:

See description under parameter 502.

Description of choice:

See description under parameter 502.

509 Bus jog 1

(BUS JOG 1 SPEED)

Value:

0.0 - parameter 202 ★ 200 rpm

Function:

This is where to set a fixed speed (jog) that is activated via the serial communication port.

This function is the same as in parameter 213.

Description of choice:

The jog frequency fJOG can be selected in the range between fMIN (parameter 201) and fMAX (parameter 202).

510 Bus jog 2

(BUS JOG 2 SPEED)

Value:

0.0 - parameter 202 ★ 200 rpm

Function:

This is where to set a fixed speed (jog) that is activated via the serial communication port.

This function is the same as in parameter 213.

Description of choice:

The jog speed can be selected in the range between nMIN (parameter 201) and nMAX (parameter 202).

512 Telegram profile

(TELEGRAM PROFILE)

Value:

Fieldbus profile (FIELDBUS PROFILE)	[0]
★FC Drive (FC DRIVE)	[1]

Function:

There is a choice of two different control word profiles.

Description of choice:

Select the desired control word profile.

See *Serial communication*, in the Design Guide for further information about the control word profiles. See also the dedicated fieldbus manuals for further details.

513 Bus time interval

(BUS TIMEOUT TIME)

Value:

1 - 99 sec. ★ 1 sec.

Function:

This parameter sets the maximum time expected to pass between the receipt of two consecutive telegrams. If this time is exceeded, the serial communication is assumed to have stopped and the desired reaction is set in parameter 514.

Description of choice:

Set the desired time.

514 Bus time interval function (BUS TIMEOUT FUNC)

Value:

★Off (OFF)	[0]
Freeze output (FREEZE OUTPUT)	[1]
Stop (STOP)	[2]
Jogging (JOGGING)	[3]
Max. speed (MAX SPEED)	[4]
Stop and trip (STOP AND TRIP)	[5]

Function:

This parameter selects the desired reaction of the frequency converter when the set time for bus timeout (parameter 513) has been exceeded.

If choices [1] to [5] are activated, relay 01 and relay 04 will be de-activated.

If more time-outs occur at the same time the frequency converter will give the following priority to the time-out function:

1. Parameter 318 *Function after time out*
2. Parameter 346 *Function after encoder loss*
3. Parameter 514 *Bus time interval function*.

Description of choice:

The output frequency of the frequency converter can: be frozen at the present value, be frozen at the reference, go to stop, go to jogging speed (parameter 213), go to max. output speed (parameter 202) or stop and activate a trip.

Parameter no.	Description	Display text	Unit	Updating interval
515	Reference %	(REFERENCE)	%	80 msec.
516	Reference Unit	(REFERENCE [UNIT])	Hz, Nm or rpm	80 msec.
518	Frequency	(FREQUENCY)	Hz	80 msec.
520	Current	(MOTOR CURRENT)	Amp	80 msec.
521	Torque	(TORQUE)	%	80 msec.
522	Power, kW	(POWER (KW))	kW	80 msec.
523	Power, HP	(POWER (HP))	HP (US)	80 msec.
524	Motor voltage	(MOTOR VOLTAGE)	V	80 msec.
525	DC link voltage	(DC LNK VOLTAGE)	V	80 msec.
526	Motor temp.	(MOTOR THERMAL)	%	80 msec.
527	VLT temp.	(VLT THERMAL)	%	80 msec.
528	Digital input	(DIGITAL INPUT)	Binary code	2 msec.
529	Terminal 53, analogue input	(ANALOG INPUT 53)	V	20 msec.
530	Terminal 54, analogue input	(ANALOG INPUT 54)	V	20 msec.
531	Terminal 60, analogue input	(ANALOG INPUT 60)	mA	20 msec.
532	Pulse reference	(PULSE REFERENCE)	Hz	20 msec.
533	External reference %	(EXT. REFERENCE)	%	20 msec.
534	Status word	(STATUS WORD [HEX])	Hex code	20 msec.
535	Brake power/2 min.	(BR. ENERGY/2 MIN)	kW	
536	Brake power/sec.	(BRAKE ENERGY/S)	kW	
537	Heat sink temperature	(HEATSINK TEMP.)	°C	1.2 sec.
538	Alarm word	(ALARM WORD [HEX])	Hex code	20 msec.
539	VLT control word	(CONTROLWORD [HEX])	Hex code	2 msec.
540	Warning word, 1	(WARN. WORD 1)	Hex code	20 msec.
541	Extended status word Hex	(EXT. STATUS WORD)	Hex code	20 msec.
557	Motor RPM	(MOTOR RPM)	RPM	80 msec.
558	Motor RPM x scaling	(MOTOR RPM X SCALE)	-	80 msec.

Function:

These parameters can be read out via the serial communication port and via the display in Display mode, see also parameters 009 - 012.

Description of choice:

Reference %, parameter 515:

★ = factory setting. () = display text [] = value for use in communication via serial communication port

The value shown corresponds to the total reference (sum of digital/analogue/preset/bus/freeze ref./catch-up and slow-down).

Reference Unit, parameter 516:

Gives the present value of terminals 17/29/53/54/60 in the unit resulting from the choice of configuration in parameter 100 (Hz, Nm or rpm). See also parameter 205 if required.

Frequency, parameter 518:

The value shown corresponds to the actual motor frequency f_M .

Motor current, parameter 520:

The value shown corresponds to the given motor current measured as a mean value I_{RMS} . The value is filtered, which means that approx. 1.3 seconds may pass from an input value changes until the data read-out changes values.

Torque, parameter 521:

The value shown is the torque, with sign, supplied to the motor shaft. The value is given as a percentage of the rated torque. There is not exact linearity between 160% motor current and torque in relation to the rated torque. Some motors supply more torque than that. Consequently, the min. value and the max. value will depend on the max. motor current as well as the motor used. The value is filtered, which means that approx. 1.3 seconds may pass from an input changes value until the data read-out changes values.

NB!:

If the setting of the motor parameters does not match the motor applied, the read-out values will be inaccurate and may become negative, even if the motor is not running or is producing a positive torque.

Power, (kW), parameter 522:

The value shown is calculated on the basis of the actual motor voltage and motor current. The value is filtered, which means that it may take approx. 1.3 seconds from an input value changes until the data read-out changes values.

Power (HP), parameter 523:

The value shown is calculated on the basis of the actual motor voltage and motor current. The value is indicated in the form of HP. The value is filtered, which means that approx. 1.3 seconds may pass from an input value changes until the data read-out changes values.

Motor voltage, parameter 524:

★ = factory setting. () = display text [] = value for use in communication via serial communication port

The value shown is a calculated value used for controlling the motor.

DC link voltage, parameter 525:

The value shown is a measured value. The value is filtered, which means that approx. 1.3 seconds may pass from an input value changes until the data read-out changes values.

Motor temp., parameter 526:

The value shown is the calculated, estimated percent thermal load on the motor.

VLT temp., parameter 527:

Only whole numbers are displayed.

Digital input, parameter 528:

The value shown indicates the signal status from the 8 digital terminals (16, 17, 18, 19, 27, 29, 32 and 33). The read-out is binary and the digit at the extreme left gives the status of terminal 16, while the digit at the extreme right gives the status of terminal 33.

Terminal 53, analogue input, parameter 529:

The value shown indicates the signal value on terminal 53. The scaling (parameters 309 and 310) does not influence the read-out. Min. and max. are determined by the offset and gain adjustment of the AD-converter.

Terminal 54, analogue input, parameter 530:

The value shown indicates the signal value on terminal 54. The scaling (parameters 312 and 313) does not influence the read-out. Min. and max. are determined by the offset and gain adjustment of the AD-converter.

Terminal 60, analogue input, parameter 531:

The value shown indicates the signal value on terminal 60. The scaling (parameters 315 and 316) does not influence the read-out. Min. and max. are determined by the offset and gain adjustment of the AD-converter.

Pulse reference, parameter 532:

The value shown indicates any pulse reference in Hz connected to one of the digital inputs.

External reference %, parameter 533:

The value stated gives, as a percentage, the sum of external references (sum of analogue/bus/pulse).

Status word, parameter 534:

Indicates the status word transmitted via the serial communication port in Hex code from the frequency converter. See the Design Guide.

Brake power/2min., parameter 535:

Indicates the brake power transmitted to an external brake resistor. The mean power is calculated on an ongoing basis for the latest 120 sec.

Brake power/sec., parameter 536:

Indicates the given brake power transmitted to an external brake resistor. Stated as an instantaneous value.

Heat sink temperature, parameter 537:

States the given heat sink temperature of the frequency converter. The cut-out limit is $90 \pm 5^\circ\text{C}$, while the unit cuts back in at $60 \pm 5^\circ\text{C}$.

Alarm word, parameter 538:

States in Hex format whether there is an alarm on the frequency converter. See section *Warning word 1, Extended status word and Alarm word for further information.*

VLT control word, parameter 539:

Gives the control word sent via the serial communication port in Hex code to the frequency converter. See the *Design Guide* for further information.

Warning word, 1, parameter 540:

States in Hex format whether there is a warning on the frequency converter. See section *Warning word 1, Extended status word and Alarm word for further information.*

Extended status word Hex, parameter 541:

States in Hex format whether there is a warning on the frequency converter.

See section *Warning word 1, Extended status word and Alarm word for further information.*

Motor RPM, parameter 557:

The displayed value corresponds to the actual motor RPM.

Motor RPM x scaling, parameter 558:

The displayed value corresponds to the actual motor RPM multiplied by a factor (scaling) set in parameter 008.

★ = factory setting. () = display text [] = value for use in communication via serial communication port

■ Technical functions
■ Introduction

The purpose of Technical function parameters is reading out technical status and conditions of the drive. The selection of read outs of warnings and alarms is also included in this parameter group.

PNU #	Parameter description	Factory setting	Range	Changes during operation	4-Setup	Conversion index	Data type
600	Operating data: Operating hours			No	No	74	7
601	Operating data: Hours run			No	No	74	7
602	Operating data: kWh counter			No	No	1	7
603	Operating data: Number of power-up's			No	No	0	6
604	Operating data: Number of overtemperatures			No	No	0	6
605	Operating data: Number of overvoltages			No	No	0	6
606	Data log: Digital input			No	No	0	5
607	Data log: Bus commands			No	No	0	6
608	Data log: Bus status word			No	No	0	6
609	Data log: Reference			No	No	-1	3
611	Data log: Motor frequency			No	No	-1	3
612	Data log: Motor voltage			No	No	-1	6
613	Data log: Motor current			No	No	-2	3
614	Data log: DC link voltage			No	No	0	6
615	Fault log: Error code			No	No	0	5
616	Fault log: Time			No	No	-1	7
617	Fault log: Value			No	No	0	3
618	Reset of kWh counter	No reset		Yes	No	0	5
619	Reset of hours-run counter	No reset		Yes	No	0	5
620	Operating mode Normal function	Normal function		No	No	0	5
621	Nameplate: VLT type			No	No	0	9
622	Nameplate: Power section			No	No	0	9
623	Nameplate: VLT ordering number			No	No	0	9
624	Nameplate: Software version no.			No	No	0	9
625	Nameplate: LCP identification no.			No	No	0	9
626	Nameplate: Database identification no.			No	No	-2	9
627	Nameplate: Power section identification no.			No	No	0	9
628	Nameplate: Application option type			No	No	0	9
629	Nameplate: Application option ordering no.			No	No	0	9
630	Nameplate: Communication option type			No	No	0	9
631	Nameplate: Communication option ordering no.			No	No	0	9
639	Flash Test	Off		Yes	No	0	5

See also *Operation and Display* for further information regarding Changes during operation, 4-Setup and Conversion index.

★ = factory setting. () = display text [] = value for use in communication via serial communication port

Parameter no.	Description	Display text	Unit	Range
Operating data				
600	Operating hours	(OPERATING HOURS)	Hours	0 - 130,000.0
601	Hours run	(RUNNING HOURS)	Hours	0 - 130,000.0
602	kWh counter	(KWH COUNTER)	kWh	0 - 9999
603	No. of cut-ins	(POWER UP's)	Nos.	0 - 9999
604	No. of overtemps	(OVER TEMP's)	Nos.	0 - 9999
605	No. of overvoltages	(OVER VOLT'S)	Nos.	0 - 9999

Function:

These parameters can be read out via the serial communication port and via the display in the parameters.

Description of choice:

Operating hours, parameter 600:

Indicates the number of hours in which the frequency converter has been in operation.

The value is updated in the frequency converter every hour and saved when the unit is turned off.

Hours run, parameter 601:

Indicates the number of hours in which the frequency converter has been in operation since reset in parameter 619.

The value is updated in the frequency converter every hour and saved when the unit is turned off.

kWh counter, parameter 602:

States the power consumption from mains in kWh as a mean value over one hour. Reset counter: Parameter 618.

No. of cut-ins, parameter 603:

States the number of power-ups of the supply voltage to the frequency converter.

No. of overtemps, parameter 604:

States the number of temperature faults there has been on the frequency converter.

No. of overvoltages, parameter 605:

States the number of overvoltages there has been on the frequency converter.

Parameter no.	Description	Display text	Unit	Range
Data log				
606	Digital inputs	(LOG: DIGITAL INP)	Decimal	0 - 255
607	Control word	(LOG: CONTROL WORD)	Decimal	0 - 65535
608	Status word	(LOG: BUS STAT WD)	Decimal	0 - 65535
609	Reference	(LOG: REFERENCE)	%	0 - 100
611	Output frequency	(LOG: MOTOR FREQ.)	Hz.	0.0 - 999.9
612	Output voltage	(LOG: MOTOR VOLT)	Volt	50 - 1000
613	Output current	(LOG: MOTOR CURR.)	Amp	0.0 - 999.9
614	DC link voltage	(LOG: DC LINK VOLT)	Volt	0.0 - 999.9

Function:

Via this parameter it is possible to see up to 20 data-logs, where [0] is the latest log and [19] the oldest. Each data-log is made every 160 ms as long as a start signal has been given. If a stop signal is given, the latest 20 data-logs will be saved and the values will be available on the display. This is useful, e.g. when carrying out service after a trip.

This parameter can be read out via the serial communication port or via the display.

Description of choice:

The data-log number is stated in square brackets: [1]. Data-logs are frozen if there is a trip and released when the frequency converter is subsequently reset. Data-logging is active while the motor is running.

Digital inputs, parameter 606:

The value for the digital inputs is given as a decimal figure within the range of 0-255.

The data-log number is stated in square brackets: [1]

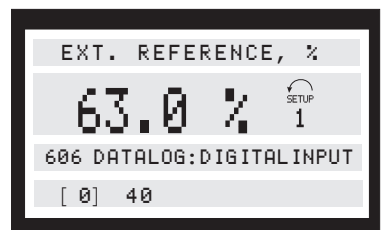

Control word, parameter 607:

The value for the control word is given as a decimal figure within the range of 0-65535.

★ = factory setting. () = display text [] = value for use in communication via serial communication port

Status word, parameter 608:

The value for the bus status word is given as a decimal figure within the range of 0-65535.

Reference, parameter 609:

The value of the reference is stated as a % in the interval 0 - 100%.

Output frequency, parameter 611:

The value of the motor frequency is stated as a frequency in the interval 0.0 - 999.9 Hz.

Output voltage, parameter 612:

The value of the motor voltage is stated as Volts in the interval 50 - 1000 V.

Output current, parameter 613:

The value for the motor current is stated as Amps in the interval 0.0 - 999.9 A.

DC link voltage, parameter 614:

The value of the DC link voltage is stated as Volts in the interval 0.0 - 999.9 V.

615 Fault log: Error code

(F.LOG: ERROR COD)

Value:

[Index 1 - 10] Error code 0 - 44

Function:

This parameter makes it possible to see the reason why a trip occurs.

10 (0-10) log values are stored.

The lowest log number [1] contains the latest/most recently saved data value; the highest log number [10] contains the oldest data value.

Description of choice:

Given as a number code, in which the trip number refers to an alarm code that can be seen from the table in section *List of warnings and alarms*.

Reset the fault log after manual initialisation.

616 Fault log: Time

(F.LOG: TIME)

Value:

[Index 1 - 10]

Function:

This parameter makes it possible to see the total number of operating hours before the trip occurred.

10 (0-10) log values are stored.

The lowest log number [1] contains the latest/most recently saved data value, while the highest log number [10] contains the oldest data value.

Description of choice:

Read out as an option.

Indication range: 0.0 - 9999.9.

Reset the fault log after manual initialisation.

617 Fault log: Value

(F.LOG: VALUE)

Value:

[Index 1 - 10]

Function:

This parameter makes it possible to see at what current or voltage a given trip occurred.

Description of choice:

Read out as one value.

Indication range: 0.0 - 999.9.

Reset the fault log after manual initialisation.

618 Reset of kWh counter

(RESET KWH COUNT)

Value:

No reset (DO NOT RESET)	[0]
Reset (RESET COUNTER)	[1]

Function:

Reset to zero of kWh hour counter (parameter 602).

Description of choice:

If *Reset* [1] has been selected and when the [OK] key is pressed, the kWh counter of the frequency converter is reset. This parameter cannot be selected via the serial port, RS 485.



NB!:

When the [OK] key has been activated, the reset has been carried out.

619 Reset of hours-run counter

(RESET RUN. HOUR)

Value:

No reset (DO NOT RESET)	[0]
Reset (RESET COUNTER)	[1]

Function:

Reset to zero of hours-run counter (parameter 601).

★ = factory setting. () = display text [] = value for use in communication via serial communication port

Description of choice:

If *Reset* [1] has been selected and when the [OK] key is pressed, the hours-run counter of the frequency converter is reset. This parameter cannot be selected via the serial port, RS 485.



NB!:

When the [OK] key has been activated, the reset has been carried out.

620 OPERATION MODE

Value:

★Normal function (NORMAL OPERATION)	[0]
Initialisation (INITIALIZE)	[3]

Function:

Operation mode In addition to its normal function, this parameter can be used for two different tests. Also, all parameters (except parameters 603-605) can be initialized. This function will not become active until the mains supply to the frequency converter has been turned off and then turned on again.

Description of choice:

Normal function [0] is selected for normal operation with the motor in the selected application.

Initialisation [3] is selected if the factory setting of the unit is desired without resetting parameters 500, 501 + 600 - 605 + 615 - 617.

The motor must be stopped before initialisation can be carried out.

Procedure for initializing:

1. Select Initialisation.
2. Press the [OK] key.
3. Cut off the mains supply and wait for the light in the display to go out.
4. Connect to mains.

Manual initialisation can be carried out by holding down three keys at the same time as the mains voltage is connected. Manual initialisation sets all parameters to the factory setting, except 600-605. The procedure for manual initialisation is as follows:

1. Disconnect the mains voltage and wait for the light in the display to disappear.
2. Hold down [DISPLAY/STATUS]+[MENU]+[OK] while at the same time connecting the mains supply. The display will now read MANUAL INITIALIZE.
3. When the display reads UNIT READY, the frequency converter has been initialized.

Parameter no.	Description Nameplate	Display text
621	VLT type	(VLT TYPE)
622	Power section	(POWER SECTION)
623	VLT ordering number	(VLT ORDERING NO)
624	Software version number	(SOFTWARE VERSION)
625	LCP identification number	(LCP ID NO)
626	Database identification number	(PARAM DB ID)
627	Power section identification number	(POWER UNIT DB ID)
628	Application option type	(APP. OPTION)
629	Application option ordering number	(APP. ORDER NO)
630	Communication option type	(COM. OPTION)
631	Communication option ordering number	(COM. ORDER NO)

Function:

The key data of the unit can be read out via the display or the serial communication port.

Description of choice:

VLT type, parameter 621:

VLT Type indicates the unit size and basic function concerned.

For example: VLT 5008 380-500 V.

Power section, parameter 622:

The power section states the given power section being used.

★ = factory setting. () = display text [] = value for use in communication via serial communication port

For example: Extended with brake.

VLT ordering number, parameter 623:

Ordering number gives the ordering number of the VLT type in question.

For example: 175Z0072.

Software version number, parameter 624:

Software version gives the version number.

For example: V 3,10.

LCP identification number, parameter 625:

The key data of the unit can be read out via the display or the serial communication port.

For example: ID 1,42 2 kB.

Database identification number, parameter 626:

The key data of the unit can be read out via the display or the serial communication port.

For example: ID 1,14.

Power section identification number, parameter 627:

The key data of the unit can be read out via the display or the serial communication port.

For example: ID 1,15.

Application option type, parameter 628:

This gives the type of application options fitted with the frequency converter.

Application option ordering number, parameter 629:

This gives the ordering number for the application option.

Communication option type, parameter 630:

This gives the type of communication options fitted with the frequency converter

Communication option ordering number, parameter 631:

This gives the ordering number for the communication option.

639 FLASH TEST

Value:

★Off (OFF)	[0]
On (ON)	[1]

Function:

Checks the consistency of the program in flash prompts during every power-up.

■ Trouble-shooting

Symptom

How to handle

1. Motor runs unevenly

If the motor runs unevenly, but no fault is given, this may be because the frequency converter has been wrongly set.
Adjust the motor data settings or run an AMA.
Contact Danfoss if the new setting does not make the motor run evenly

2. Motor does not run

Check if there is a backlight in the display.
If there is a backlight, please check if a fault message is displayed. If yes, please consult the Warnings-section, if no, please refer to symptom 5.
If there is no backlight, check if the frequency converter is connected to mains supply. If yes, please refer to symptom 4.

3. Motor does not brake

Please refer to section *Control with brake function* .

4. No message or backlight in display

Check if the prefuses for the VLT have blown.
If yes, call Danfoss for assistance.
If no, check if the control card is overloaded.
If so, disconnect all control signal plugs on the control card and check if the fault disappears.
If yes, make sure that the 24 V supply is not short-circuited.
If no, call Danfoss for assistance.

5. Motor stopped, light in display, but no fault report

Start the frequency converter by pressing [START] on the control panel.
Check if the display is frozen, ie. the display cannot be changed or is undefineable.
If yes, check if screened cables have been used and are connected correctly.
If no, check that the motor is connected and that all motor phases are OK.
The frequency converter must be set to run using local references:
Connect 24 V DC to terminal 27, 37 and 18
Parameter 002 = Local operation
Parameter 003 = desired reference value
The reference is changed by pressing '+' or '-'.
Is the motor running?
If yes, check whether control signals to the control card are OK.
If no, call Danfoss for assistance.

Miscellaneous

■ Status messages

Status messages appear in the 4th line of the display, see the below example. The status message will be on the display for approx. 3 seconds.

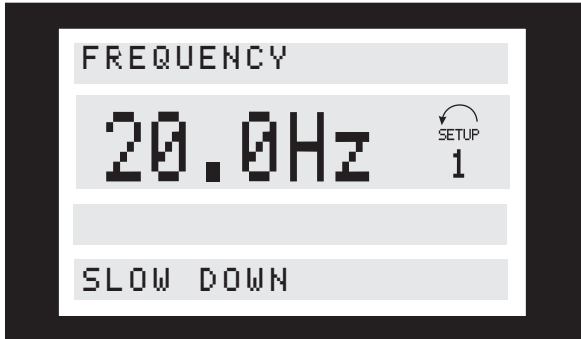
Start clockwise/anti-clockwise (REM. START FORW./REV):

Input on digital inputs and parameter data are in conflict.

(MIXED START FORW./REV):

Input on digital inputs and parameter data are in conflict.

Slow-down (REM. SLOW DOWN):

The output frequency of the frequency converter is reduced by the percentage value chosen in parameter 219.

Catch-up (REM. CATCH UP):

The output frequency of the frequency converter is increased by the percentage value chosen in parameter 219.

Output speed high (REM. SPEED HIGH):

The output frequency is higher than the value set in parameter 226. This message is only shown when the motor is running.

Output speed high (LOCAL SPEED HIGH):

The output frequency is higher than the value set in parameter 226. This message is only shown when the motor is running.

Output speed high (MIXED SPEED HIGH):

The output frequency is higher than the value set in parameter 226. This message is only shown when the motor is running.

Output speed low (REM. SPEED LOW):

The output frequency is lower than the value set in parameter 225. This message is only shown when the motor is running.

Output speed low (LOCAL SPEED LOW):

The output frequency is lower than the value set in parameter 225. This message is only shown when the motor is running.

Output speed low (MIXED SPEED LOW):

The output frequency is lower than the value set in parameter 225. This message is only shown when the motor is running.

Output current high (REM. CURRENT HIGH):

The output current is higher than the value set in parameter 224. This message is only shown when the motor is running.

Output current high (LOCAL CURRENT HIGH):

The output current is higher than the value set in parameter 224. This message is only shown when the motor is running.

Output current high (MIXED CURRENT HIGH):

The output current is higher than the value set in parameter 224. This message is only shown when the motor is running.

Output current low (REM. CURRENT LOW):

The output current is lower than the value set in parameter 223. This message is only shown when the motor is running.

Output current low (LOCAL CURRENT LOW):

The output current is lower than the value set in parameter 223. This message is only shown when the motor is running.

Output current low (MIXED CURRENT LOW):

The output current is lower than the value set in parameter 223. This message is only shown when the motor is running.

Braking max. (REM. BRAKING MAX):

The brake is functioning. Optimum braking is effected when the value in parameter 402 *Braking power limit, KW* is exceeded.

Braking max. (LOCAL BRAKING MAX):

The brake is functioning. Optimum braking is effected when the value in parameter 402 *Braking power limit, KW* is exceeded.

Braking max. (MIXED BRAKING MAX):

The brake is functioning. Optimum braking is effected when the value in parameter 402 *Braking power limit, KW* is exceeded.

Braking (REM. BRAKING):

The brake is functioning.

Braking (LOCAL BRAKING):

The brake is functioning.

Braking (MIXED BRAKING):

The brake is functioning.

Ramp operation (REM. RAMPING):

Remote has been selected in parameter 002 and the output speed is changed in accordance with the ramps set.

Ramp operation (LOCAL RAMPING):

Local has been selected in parameter 002 and the output speed is changed in accordance with the ramps set.

Ramp operation (MIXED RAMPING):

Local has been selected in parameter 002 and the output speed is changed in accordance with the ramps set.

Running, remote control (REM. RUN OK):

Remote control has been selected in parameter 002 and a start command is given on either terminal 18 (START or LATCHED START in parameter 302), terminal 19 (START REVERSE parameter 303) or via the serial bus.

Running, local control (LOCAL RUN OK):

Local control has been selected in parameter 002 and a LCP start command has been given

Running, local control (MIXED RUN OK):

Local control has been selected in parameter 002 and a start command is given on terminal 19 (START REVERSE parameter 303).

VLT ready, remote control (REM. UNIT READY):

Remote control has been selected in parameter 002 and *Coasting stop* inverse in parameter 304, and there is 0 V on terminal 27.

VLT ready, local control (LOCAL UNIT READY):

Local has been selected in parameter 002 and Hardware coast on terminal 37 is 0 V.

VLT ready, local control (MIXED UNIT READY):

Local has been selected in parameter 002 and *Coasting inverse* in parameter 304, and there is 0 V on terminal 27.

Quick-stop, remote control (REM. QSTOP):

Remote control has been selected in parameter 002 and the frequency converter has stopped via a quick-stop signal on terminal 27 (or possibly via the serial communication port).

Quick-stop, local (MIXED QSTOP):

Local has been selected in parameter 002 and the frequency converter has stopped via a quick-stop signal on terminal 27.

DC stop, remote control (REM. DC STOP):

Remote control has been selected in parameter 002 and the frequency converter has stopped via a DC stop signal on a digital input (or possibly via the serial communication port).

DC braking, local (MIXED DC STOP):

Local has been selected in parameter 002 and the frequency converter has stopped via a DC braking signal on terminal 27.

Stop, remote controlled (REM. STOP):

Remote control has been selected in parameter 002 and the frequency converter has stopped via the control panel or a digital input (or possibly via the serial communication port).

Stop, local (LOCAL STOP):

Local has been selected in parameter 002 and the frequency converter has stopped via the control panel.

Stop, local (MIXED STOP):

Local has been selected in parameter 002 and the frequency converter has stopped via the control panel or the digital input (or possibly via the serial communication port).

Stand by (REM. STAND BY):

Remote control has been selected in parameter 002. The frequency converter will start when it receives a start signal via a digital input (or the serial communication port).

Freeze output (REM. FREEZE OUTPUT):

Remote control has been selected in parameter 002 together with *Freeze reference* in parameter 300, 301, 305, 306 or 307, and the terminal in question (16, 17, 29, 32 or 33) has been activated (or possibly via the serial communication port).

Jog operation, remote controlled

(REM.RUN JOG):

Remote control has been selected in parameter 002 and *Jog* in parameter 300, 301, 305, 306 or 307, and the terminal in question (16, 17, 29, 32 or 33) has been activated (or possibly via the serial communication port).

Jog operation, local (LOCAL RUN JOG):

Local has been selected in parameter 002 and *LCP Jog* enabled and activated.

Jog operation, local (MIXED RUN JOG):

Local has been selected in parameter 002 and *LCP Jog* enabled and activated.

Overvoltage control (REM. OVER VOLTAGE CONTROL):

Miscellaneous

Remote has been selected in parameter 002 and the intermediate circuit voltage of the frequency converter is too high. The frequency converter is trying to avoid a trip by increasing the output frequency. This function is activated in parameter 400.

Overvoltage control (LOCAL OVER VOLTAGE CONTROL):

Local has been selected in parameter 002 and the intermediate circuit voltage of the frequency converter is too high. The frequency converter is trying to avoid a trip by increasing the output frequency. This function is activated in parameter 400.

Overvoltage control (MIXED OVER VOLTAGE CONTROL):

Local has been selected in parameter 002 and the intermediate circuit voltage of the frequency converter is too high. The frequency converter is trying to avoid a trip by increasing the output frequency. This function is activated in parameter 400.

Automatic Motor Adaptation (REM. AUTO MOTOR ADAPT):

Remote has been selected in parameter 002.
AMA READY: Automatic Motor adaptation is waiting for start.
AMA RUNNING: Automatic Motor adaptation is running.
AMA FINISHED: Automatic Motor adaptation has finished.

Automatic Motor Adaptation (LOCAL AUTO MOTOR ADAPT):

Local has been selected in parameter 002.
AMA READY: Automatic Motor adaptation is waiting for start.
AMA RUNNING: Automatic Motor adaptation is running.
AMA FINISHED: Automatic Motor adaptation has finished.

Automatic Motor Adaptation (MIXED AUTO MOTOR ADAPT):

Local has been selected in parameter 002.
AMA READY: Automatic Motor adaptation is waiting for start.
AMA RUNNING: Automatic Motor adaptation is running.
AMA FINISHED: Automatic Motor adaptation has finished.

Brake check finished (REM. BRAKECHECK OK):

Remote has been selected in parameter 002. Brake check of brake resistor and brake transistor tested successfully.

Brake check finished (LOCAL BRAKECHECK OK):

Local has been selected in parameter 002.

Brake check of brake resistor and brake transistor tested successfully.

Brake check finished (MIXED BRAKECHECK OK):

Local has been selected in parameter 002. Brake check of brake resistor and brake transistor tested successfully.

Exceptions XXXX (EXCEPTIONS XXXX):

The microprocessor of the control card has stopped and the frequency converter is out of operation. The cause may be noise on the mains, motor or control cables, leading to a stop of the control card microprocessor. Check for EMC-correct connection of these cables.

Ramp stop in fieldbus mode (REM. OFF1):

OFF1 means that the drive is stopped by ramp down. The command to stop has been given over a fieldbus or the RS485 serial port (select fieldbus in parameter 512).

Quick stop in fieldbus mode (REM. OFF3):

OFF3 means that the drive is stopped by quick stop. The command to stop has been given over a fieldbus or the RS485 serial port (select fieldbus in parameter 512).

Start not possible (REM. START INHIBIT):

The drive is in fieldbus profile mode. OFF1, OFF2 or OFF3 have been activated. OFF1 must be toggled to be able to start (OFF1 set from 1 to 0 to 1)

Not ready for operation (REM. UNIT NOT READY):

The drive is in Fieldbus profile mode (parameter 512). The drive is not ready for operation as bit 00, 01 or 02 in the control word is "0", the drive has tripped or there is no mains supply (only seen on units with 24 V DC supply).

Ready for operation (REM. CONTROL READY) :

The drive is ready for operation. For extended units supplied with a 24 V DC supply the message also comes up when there is no mains supply.

Bus jog, remote controlled (REM. RUN BUS JOG1):

Remote control has been selected in parameter 002 and the Fieldbus has been selected in parameter 512. Bus Jog has been selected by the fieldbus or serial bus.

Bus jog, remote controlled (REM. RUN BUS JOG2):

Remote control has been selected in parameter 002 and Fieldbus has been selected in parameter 512. Bus Jog has been selected by the fieldbus or serial bus.

■ List of warnings and alarms

The table gives the different warnings and alarms and indicates whether the fault locks the frequency converter. After Trip locked, the mains supply must be cut and the fault must be corrected. Reconnect the mains supply and reset the frequency converter before being ready.

Wherever a cross is placed under both Warning and Alarm, this can mean that a warning precedes the alarm. It can also mean that it is possible to program whether a given fault is to result in a warning or an alarm. This is possible, e.g. in parameter 404 *Brake check*. After a trip, alarm and warning will flash, but if the fault is removed, only alarm will flash. After a reset, the frequency converter will be ready to start operation again.

No.	Description	Warning	Alarm	Trip lockeds
1	10 Volts low (10 VOLT LOW)	X		
2	Live zero fault (LIVE ZERO ERROR)	X	X	
3	No motor (NO MOTOR)	X		
4	Phase fault (MAINS PHASE LOSS)	X	X	X
5	Voltage warning high (DC LINK VOLTAGE HIGH)	X		
6	Voltage warning low (DC LINK VOLTAGE LOW)	X		
7	Overvoltage (DC LINK OVERVOLT)	X	X	
8	Undervoltage (DC LINK UNDERVOLT)	X	X	
9	Inverter overladed (INVERTER TIME)	X	X	
10	Motor overloaded (MOTOR TIME)	X	X	
11	Motor thermistor (MOTOR THERMISTOR)	X	X	
12	Torque limit (TORQUE LIMIT)	X	X	
13	Overcurrent (OVERCURRENT)	X	X	X
14	Earth fault (EARTH FAULT)		X	X
15	Switch mode fault (SWITCH MODE FAULT)		X	X
16	Short-circuit (CURR.SHORT CIRCUIT)		X	X
17	Standard bus timeout (STD BUS TIMEOUT)	X	X	
18	HPFB bus timeout (HPFB TIMEOUT)	X	X	
19	Fault in EEprom on power card (EE ERROR POWER CARD)	X		
20	Fault in EEprom on conrol card (EE ERROR CTRL. CARD)	X		
22	Auto-optimisation not OK (AUTO MOT ADAPT FAIL)		X	
23	Brake test failed (BRAKE TEST FAILED)	X	X	
25	Brake resistor short-circuited (BRAKE RESISTOR FAULT)	X		
26	Brake resistor power 100% (BRAKE POWER 100%)	X	X	
27	Brake transistor short-circuited (BRAKE IGBT FAULT)	X		
29	Heat-sink temperature too high (HEAT SINK OVER TEMP.)		X	X
30	Motor phase U missing (MISSING MOT.PHASE U)		X	
31	Motor phase V missing (MISSING MOT.PHASE V)		X	
32	Motor phase W missing (MISSING MOT.PHASE W)		X	
34	Profibus communication fault (PROFIBUS COMM. FAULT)	X	X	
35	Out of frequency range (OUT FREQ RNG/ROT LIM)	X		
36	Mains failure (MAINS FAILURE)	X	X	
37	Inverter fault (INVERTER FAULT)		X	X
39	Check parameters 104 and 106 (CHECK P.104 & P.106)	X		
40	Check parameters 103 and 105 (CHECK P.103 & P.105)	X		
41	Motor too big (Motor too big)	X		
42	Motor too small (Motor too small)	X		
43	Brake fault (BRAKE FAULT)		X	X
44	Encoder loss (ENCODER FAULT)	X	X	
46	Watch dog			X
48	Tracking fault		X	

Miscellaneous

■ Warnings

The display flashes between normal state and warning. A warning comes up on the first and second line of the display. See examples below:

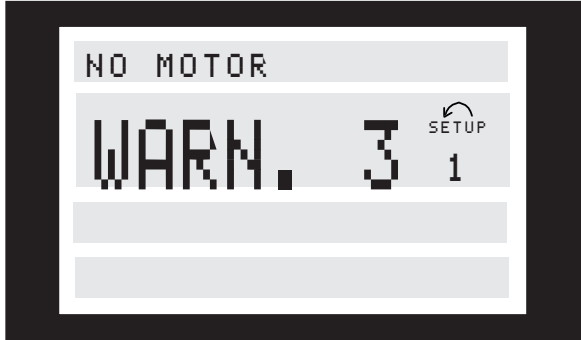

Alarm messages

The alarm comes up in the 2. and 3. line of the display, see example below:



WARNING 1

Under 10 Volts (10 VOLT LOW):

The 10 Volts voltage from terminal 50 on the control card is below 10 Volts. Remove some of the load from terminal 50, as the 10 Volts supply is overloaded. Max. 17 mA/min. 590 Ω.

WARNING/ALARM 2

Live zero fault (LIVE ZERO ERROR):

The current signal on terminal 60 is less than 50% of the value set in parameter 315 *Terminal 60, min. scaling*.

WARNING/ALARM 3

No motor (NO MOTOR):

The motor check function (see parameter 122) indicates that no motor has been connected to the output of the frequency converter.

WARNING/ALARM 4

Phase fault (MAINS PHASE LOSS):

A phase is missing on the supply side or the mains voltage imbalance is too high. This message can also appear if there is a fault in the input rectifier on the frequency converter. Check the supply voltage and supply currents to the frequency converter.

WARNING 5

Voltage warning high (DC LINK VOLTAGE HIGH):

The intermediate circuit voltage (DC) is higher than the overvoltage limit of the control system. The frequency converter is still active.

WARNING 6

Voltage warning low (DC LINK VOLTAGE LOW):

The intermediate circuit voltage (DC) is below the undervoltage limit of the control system. The frequency converter is still active.

WARNING/ALARM 7

Overvoltage (DC LINK OVERVOLT):

If the intermediate circuit voltage (DC) exceeds the inverter overvoltage limit (see table), the frequency converter will trip. Furthermore, the voltage will be stated in the display. The fault can be eliminated by connecting a brake resistor (if the frequency converter has an integral brake chopper, EB or SB). In addition, *Brake function/overvoltage control* can be activated in parameter 400.

Alarm/warning

limits:

	3 x 200 - 240 V	3 x 380 - 500 V
	[VDC]	[VDC]
Undervoltage	211	402
Voltage warning low	222	423
Voltage warning high (w/o brake - w/brake)	384/405	801/840
Overvoltage	425	855

The voltages stated are the intermediate circuit voltage of the frequency converter with a tolerance of ± 5 %. The corresponding mains voltage is the intermediate circuit voltage divided by 1.35

WARNING/ALARM 8

Undervoltage (DC LINK UNDERVOLT):

If the intermediate circuit voltage (DC) drops below the inverter lower voltage limit (see table on previous page), it will be checked whether 24 V power supply is connected.

If no 24 V power supply is connected, the frequency converter will trip after a given time that depends on the unit.

Furthermore, the voltage will be stated in the display. Check whether the supply voltage matches the frequency converter, see technical data.

WARNING/ALARM 9

Inverter overload (INVERTER TIME):

The electronic, thermal inverter protection reports that the frequency converter is about to cut out because of an overload (too high current for too long). The counter for electronic, thermal inverter protection gives a warning at 98% and trips at 100%, while giving an alarm. The frequency converter cannot be reset until the counter is below 90%.

The fault is that the frequency converter is overloaded by more than 100% for too long.

WARNING/ALARM 10

Motor overtemperature (MOTOR TIME):

According to the electronic thermal protection (ETR), the motor is too hot. Parameter 128 allows a choice of whether the frequency converter is to give a warning or an alarm when the counter reaches 100%. The fault is that the motor is overloaded by more than 100% for too long. Check that motor parameters 102-106 have been set correctly.

WARNING/ALARM 11

Motor thermistor (MOTOR THERMISTOR):

The thermistor or the thermistor connection has been disconnected. Parameter 128 allows a choice of whether the frequency converter is to give a warning or an alarm. Check that the thermistor has been correctly connected between terminal 53 or 54 (analogue voltage input) and terminal 50 (+ 10 Volts supply).

WARNING/ALARM 12

Torque limit (TORQUE LIMIT):

The torque is higher than the value in parameter 221 (in motor operation) or the torque is higher than the value in parameter 222 (in regenerative operation).

WARNING/ALARM 13

Overcurrent (OVERCURRENT):

The inverter peak current limit (approx. 200% of the rated current) has been exceeded. The warning will last approx. 1-2 seconds, following which the frequency converter will trip, while giving an alarm. Turn off the frequency converter and check whether

the motor shaft can be turned and whether the motor size matches the frequency converter.

ALARM: 14

Earth fault (Earth fault):

There is a discharge from the output phases to earth, either in the cable between the frequency converter and the motor or in the motor itself.

Turn off the frequency converter and remove the earth fault.

ALARM: 15

Switch mode fault (SWITCH MODE FAULT):

Fault in the switch mode power supply (internal ± 15 V supply).

Contact your Danfoss supplier.

ALARM: 16

Short-circuiting (CURR.SHORT CIRCUIT):

There is short-circuiting on the motor terminals or in the motor itself.

Turn off the frequency converter and remove the short-circuit.

WARNING/ALARM 17

Standard bus timeout (STD BUS TIMEOUT)

There is no communication to the frequency converter. The warning will only be active when parameter 514 has been set to another value than *OFF*.

If parameter 514 has been set to stop and *trip*, it will first give a warning and then ramp down until it trips, while giving an alarm.

Parameter 513 *Bus time interval* could possibly be increased.

WARNING/ALARM 18

HPFB bus timeout (HPFB BUS TIMEOUT)

There is no communication with the frequency converter. The warning will only be active when parameter 804 has been set to another value than *OFF*.

If parameter 804 has been set to *Stop and trip*, it will first give a warning and then ramp down until it trips, while giving an alarm.

Parameter 803 *Bus time interval* could possibly be increased.

WARNING 19

Fault in the EEprom on the power card (EE ERROR POWER CARD)

There is a fault on the power card EEPROM. The frequency converter will continue to function, but is likely to fail at the next power-up. Contact your Danfoss supplier.

WARNING 20

Miscellaneous

**Fault in the EEprom on the control card
(EE ERROR CTRL CARD)**

There is a fault in the EEPROM on the control card. The frequency converter will continue to function, but is likely to fail at the next power-up. Contact your Danfoss supplier.

ALARM: 22
**Auto-optimisation not OK
(AUTO MOT ADAPT FAIL)**

A fault has been found during automatic motor adaptation. The text shown in the display indicates a fault message. The figure after the text is the error code, which can be seen in the fault log in parameter 615.

CHECK P.103,105 [0]

See section *Automatic motor adaptation, AMA*.

LOW P.105 [1]

See section *Automatic motor adaptation, AMA*.

ASYMMETRICAL IMPEDANCE [2]

See section *Automatic motor adaptation, AMA*.

MOTOR TOO BIG [3]

See section *Automatic motor adaptation, AMA*.

MOTOR TOO SMALL [4]

See section *Automatic motor adaptation, AMA*.

TIME OUT [5]

See section *Automatic motor adaptation, AMA*.

INTERRUPTED BY USER [6]

See section *Automatic motor adaptation, AMA*.

INTERNAL FAULT [7]

See section *Automatic motor adaptation, AMA*.

LIMIT VALUE FAULT [8]

See section *Automatic motor adaptation, AMA*.

MOTOR ROTATES [9]

See section *Automatic motor adaptation, AMA*.

OVER CURRENT [10]

See section *Automatic motor adaptation, AMA*.

OVER VOLTAGE (DC-LINK OVER-VOLTAGE) [11]

See section *Automatic motor adaptation, AMA*.

UNDER VOLTAGE (DC-LINK UNDER-VOLTAGE) [12]

See section *Automatic motor adaptation, AMA*.

NB!:

AMA can only be carried out if there are no alarms during tuning.

Fault during brake test (BRAKE TEST FAILED):

The brake test is only run after power-up. If *Warning* has been selected in parameter 404, the warning will come when the brake test finds a fault.

The brake test may fail for the following reasons:

No brake resistor connected or fault in the connections; defective brake resistor or defective brake transistor. A warning or alarm will mean that the brake function is still active.

WARNING 25
Brake resistor fault
(BRAKE RESISTOR FAULT):

The brake resistor is monitored during operation and if it short-circuits, the brake function is disconnected and the warning comes up. The frequency converter will still be able to work, although without the brake function. Turn off the frequency converter and replace the brake resistor.

ALARM/WARNING 26
Brake resistor power 100%
(BRAKE PWR WARN 100%):

The power transmitted to the brake resistor is calculated as a percentage, as a mean value over the last 120 sec., on the basis of the resistance value of the brake resistor (parameter 401) and the intermediate circuit voltage. The warning is active when the dissipated braking power is higher than 100%. If *Trip* [2] has been selected in parameter 403, the frequency converter will cut out while giving this alarm.

WARNING 27
Brake transistor fault
(BRAKE IGBT FAULT):

The brake transistor is monitored during operation and if it short-circuits, the brake function is disconnected and the warning comes up. The frequency converter will still be able to run, but since the brake transistor has short-circuited, substantial power will be transmitted to the brake resistor, even if it is inactive.

Turn off the frequency converter and remove the brake resistor.



Warning: There is a risk of substantial power being transmitted to the brake resistor if the brake transistor has short-circuited.

ALARM: 29
**Heat sink temperature too high
(HEAT SINK OVER TEMP.):**

If the enclosure is IP 00 or IP 20, the cut-out temperature of the heat-sink is 90°C. If IP 54 is used, the cut-out temperature is 80°C.

WARNING 23

The tolerance is $\pm 5^{\circ}\text{C}$. The temperature fault cannot be reset, until the temperature of the heat-sink is below 60°C .

The fault could be the following:

- Ambient temperature too high
- Too long motor cable

ALARM: 30

Motor phase U missing (MISSING MOT.PHASE U):

Motor phase U between frequency converter and motor is missing.

Turn off the frequency converter and check motor phase U.

ALARM: 31

Motor phase V missing (MISSING MOT.PHASE V):

Motor phase V between frequency converter and motor is missing.

Turn off the frequency converter and check motor phase V.

ALARM: 32

Motor phase W missing (MISSING MOT.PHASE W):

Motor phase W between frequency converter and motor is missing.

Turn off the frequency converter and check motor phase W.

WARNING/ALARM: 34

Profibus communication fault (PROFIBUS COMMUNICATION FAULT):

The profibus on the communication option card is not working.

WARNING: 35

Out of speed range (OUT OF SPEED RANGE):

This warning is active if the output frequency has reached its *Output speed low limit* (parameter 201) or *Output speed high limit* (parameter 202).

WARNING/ALARM: 36

Mains failure (MAINS FAILURE):

This warning/alarm is only active if the supply voltage to the frequency converter is lost and if parameter 407 *Mains fault* has been set to another value than *OFF*.

If parameter 407 has been set to *Contr. ramp-down trip* [2], the frequency converter will first give a warning and then ramp down and trip, while giving an alarm.

Check the fuses to the frequency converter.

ALARM: 37

Inverter fault (Inverter fault):

IGBT or the power card is defective. Contact your Danfoss supplier.

Auto-optimisation warnings

Automatic motor adaptation has stopped, since some parameters have probably been set wrongly, or the motor used is too big/small for AMA to be carried out.

A choice must thus be made by pressing [CHANGE DATA] and choosing 'Continue' + [OK] or 'Stop' + [OK].

If parameters need to be changed, select 'Stop'; start up AMA all over.

WARNING: 39

CHECK P.104,106

The setting of parameter 102, 104 or 106 is probably wrong. Check the setting and choose 'Continue' or 'Stop'.

WARNING: 40

CHECK P.103,105

The setting of parameter 102, 103 or 105 is probably wrong. Check the setting and choose 'Continue' or 'Stop'.

WARNING: 41

MOTOR TOO BIG

The motor used is probably too big for AMA to be carried out. The setting in parameter 102 may not match the motor. Check the motor and choose 'Continue' or 'Stop'.

WARNING: 42

MOTOR TOO SMALL

The motor used is probably too small for AMA to be carried out. The setting in parameter 102 may not match the motor. Check the motor and choose 'Continue' or 'Stop'.

ALARM: 43

Brake fault (BRAKE FAULT)

A fault has arisen on the brake. The text shown in the display indicates a fault message. The figure after the text is the fault code that can be seen in the fault log, parameter 615.

Brake check failed (BRAKE CHECK FAILED) [0]

The brake check carried out during power-up indicates that the brake has been disconnected. Check whether the brake has been connected correctly and that it has not been disconnected.

Brake resistor short-circuited (BRAKE RESISTOR FAULT) [1]

The brake output has short-circuited. Replace the brake resistor.

Brake IGBT short-circuited

(BRAKE IGBT FAULT) [2]

The brake IGBT has short-circuited. This fault means that the unit is not able to stop the brake and that, consequently, the resistor is constant being energized.

WARNING/ALARM: 44**Encoder loss (ENCODER FAULT)**

The encoder signal is interrupted from terminal 32 or 33. Check the connections.

LEDs on encoder board:

When all LEDs are ON the connection to encoder and encoder condition are OK.

LED 403 OFF: 5 V supply missing

LED 400 OFF: Channel A or inv. A missing or shortcircuited

LED 401 OFF: Channel B or inv. B missing or shortcircuited

LED 402 OFF: Channel Z or inv. Z missing or shortcircuited.

ALARM 48:**Tracking fault**

The following events can generate Alarm 48:

- Parameter 361 set too low: Extend the range
- Wrong encoder direction: Motor goes one way, the encoder goes the other way
- Running in torque limit: Insufficient torque to follow the ramp, hitting an obstruction, etc.
- Bad PID settings: Oscillations can produce large errors. Readjust the PID control (Parameters 417 and 418)

■ Warning word 1, Extended status word and Alarm word

Warning word 1, extended status word and alarm word are shown on the display in Hex format. If there are more than one warning or alarm, a sum of all warnings or alarms will be shown.

Warning word 1, extended status word and alarm word can also be displayed using the serial bus in parameter 540, 541 and 538.

Bit (Hex)	Warning word 1 (parameter 540)
000001	Fault during brake test
000002	EE-prom power card fault
000004	EE-prom control card
000008	HPFP bus timeout
000010	Standard bus timeout
000020	Overcurrent
000040	Torque limit
000080	Motor thermistor
000100	Motor overload
000200	Inverter overload
000400	Undervoltage
000800	Overvoltage
001000	Voltage warning low
002000	Voltage warning high
004000	Phase fault
008000	No motor
010000	Live zero fault (4-20 mA current signal low)
020000	10 Volts low
040000	Brake resistor power 100%
080000	Brake resistor fault
100000	Brake transistor fault
200000	Out of frequency range
400000	Fieldbus communication fault
800000	Encoder loss
1000000	Mains failure
2000000	Motor too small
4000000	Motor too big
8000000	Check P. 103 and P. 105
10000000	Check P. 104 and P. 106
20000000	Application high
40000000	Application low
80000000	Warning word 2

Bit (Hex)	Extended status word (parameter 541)
000001	Ramping
000002	Automatic motor adaptation
000004	Start clockwise/anti-clockwise
000008	Slow down
000010	Catch-up
000020	Feedback high
000040	Feedback low
000080	Output current high
000100	Output current low
000200	Output speed high
000400	Output speed low
000800	Brake test ok
001000	Braking max.
002000	Braking
008000	Out of speed range
010000	Over voltage control active

Bit (Hex)	Alarm word 1 (parameter 538)
000001	Brake test failed
000002	Trip locked
000004	AMA tuning not OK
000008	Flash fault
000010	Power-up fault
000020	ASIC fault
000040	HPFP bus timeout
000080	Standard bus timeout
000100	Short-circuiting
000200	Switchmode fault
000400	Earth fault
000800	Overcurrent
001000	Torque limit
002000	Motor thermistor
004000	Motor overload
008000	Inverter overload
010000	Undervoltage
020000	Overvoltage
040000	Phase fault
080000	Live zero fault (4 - 20 mA current signal low)
100000	Heat sink temperature too high
200000	Motor phase W missing
400000	Motor phase V missing
800000	Motor phase U missing
1000000	Fieldbus communication fault
2000000	Mains failure
4000000	Inverter fault
8000000	Brake power fault
10000000	Encoder fault
20000000	Watch dog fault
40000000	Application High
80000000	Application Low

Parameter survey

PNU #	Parameter description	Factory setting	Range	Changes during operation	4-Setup	Conversion index	Data type
001	Language	English		No	No	0	5
002	Local/remote control	Remote control		Yes	Yes	0	5
003	Local reference	000.000		Yes	Yes	-3	4
004	Active setup	Setup 1		Yes	No	0	5
005	Programming setup	Active setup		Yes	No	0	5
006	Copying of setups	No copying		No	No	0	5
007	LCP copy	No copying		No	No	0	5
008	Display scaling speed	1	0.01 - 100.00	Yes	Yes	-2	6
009	Display line 2	Speed [rpm]		Yes	Yes	0	5
010	Display line 1.1	Reference [%]		Yes	Yes	0	5
011	Display line 1.2	Motor current [A]		Yes	Yes	0	5
012	Display line 1.3	Power [kW]		Yes	Yes	0	5
013	Local operation mode	LCP control		Yes	Yes	0	5
014	Local stop	Enable		Yes	Yes	0	5
015	Local jog	Not possible		Yes	Yes	0	5
016	Local reversing	Not possible		Yes	Yes	0	5
017	Local reset of trip	Possible		Yes	Yes	0	5
018	Lock for data change	Not locked		Yes	Yes	0	5
019	Operating state at power-up, local control	Forced stop, use saved ref.		Yes	Yes	0	5
024	Userdefined Quick Menu	Not active		Yes	No	0	5
025	Quick Menu Setup	000	0-999	Yes	No	0	6

Changes during operation:

"Yes" means that the parameter can be changed, while the frequency converter is in operation. "No" means that the frequency converter must be stopped before a change can be made.

4-Setup:

"Yes" means that the parameter can be programmed individually in each of the four setups, i.e. the same parameter can have four different data values. "No" means that the data value will be the same in all four setups.

Conversion index:

This number refers to a conversion figure to be used when writing or reading by means of a frequency converter.

Conversion index	Conversion factor
74	0.1
2	100
1	10
0	1
-1	0.1
-2	0.01
-3	0.001
-4	0.0001

Data type:

Data type shows the type and length of the telegram.

Data type	Description
3	Integer 16
4	Integer 32
5	Unsigned 8
6	Unsigned 16
7	Unsigned 32
9	Text string

PNU #	Parameter description	Factory setting	Range	Changes during operation	4-Setup	Conversion index	Data type
100	Configuration	Speed control, closed loop		No	Yes	0	5
101	Torque characteristics	High - constant torque		No	Yes	0	5
102	Motor power	Depends on the unit	0.18-500 kW	No	Yes	1	6
103	Motor voltage	Depends on the unit	200 - 500 V	No	Yes	0	6
104	Motor frequency	50 Hz		No	Yes	0	6
105	Motor current	Depends on the unit	0.01- $I_{VLT,MAX}$	No	Yes	-2	7
106	Rated motor speed	Depends on the unit	100-60000 rpm	No	Yes	0	6
107	Automatic motor adaptation, AMA	Adaptation off		No	No	0	5
115	Slip Compensating	100%	-400% - +400%	Yes	Yes	0	3
116	Slip compensation time constant	0.50 sec.	0.05-5.00 sec.	Yes	Yes	-2	6
119	High starting torque	0.0 sec.	0.0 - 0.5 sec.	Yes	Yes	-1	5
120	Start delay	0.0 sec.	0.0 - 10.0 sec.	Yes	Yes	-1	5
121	Start function	Coasting in start delay time		Yes	Yes	0	5
122	Function at stop	Coasting		Yes	Yes	0	5
123	Min. speed for activating function at stop	0 rpm	0 - 600 rpm	Yes	Yes	-1	5
124	DC holding current	50 %	0 - 100 %	Yes	Yes	0	6
125	DC braking current	50 %	0 - 160 %	Yes	Yes	0	6
126	DC braking time	10.0 sec.	0.0 - 60.0 sec.	Yes	Yes	-1	6
127	DC brake cut-in speed	Off	0.0-par. 202	Yes	Yes	-1	6
128	Motor thermal protection	No protection		Yes	Yes	0	5
129	External motor fan	No		Yes	Yes	0	5
130	Start speed	0.0 rpm	0.0 - 600 rpm	Yes	Yes	-1	5
131	Initial current	0.0 Amp	0.0-par. 105	Yes	Yes	-1	6
150	Stator resistance	Depends on unit	Ohm	No	Yes	-4	7
151	Rotor resistance	Depends on unit	Ohm	No	Yes	-4	7
152	Stator leakage reactance	Depends on unit	Ohm	No	Yes	-3	7
153	Rotor leakage reactance	Depends on unit	Ohm	No	Yes	-3	7
154	Main reactance	Depends on unit	Ohm	No	Yes	-3	7
156	Pole number	4-pole motor	2-100	No	Yes	0	5
158	Ironloss resistance	10000 Ω	1 - 10000 Ω	No	Yes	0	6
161	Minimum Inertia	Depends on unit	Kgm ²	No	Yes	-4	7
162	Maximum Inertia	Depends on unit	Kgm ²	No	Yes	-4	7
163	Functional stop delay	0	0 - 5 sec	Yes	Yes	-1	7
164	Mech. brake release delay	0.5 sec	0.01 - 2.00 sec	Yes	Yes	-2	U16
165	Mech. brake initial torque	20%	+/- P221	Yes	Yes	-1	S16
166	Mech. brake initial direction	[0] Clockwise	[0] Clockwise [1] Ref. dir.	Yes	Yes	0	U8
167	Proportional gain boost, during brake release	100%	0-400%	Yes	Yes	0	S16

See also *Operation and Display* for further information regarding Changes during operation, 4-Setup and Conversion index.

PNU #	Parameter description	Factory setting	Range	Changes during operation	4-Setup	Conversion index	Data type
200	Output speed range/direction	Only clockwise, 0-4500 rpm		No	Yes	0	5
202	Output speed high limit	3000 rpm	n_{MIN} - par. 200	No	Yes	-1	6
203	Reference Range	Min - max		Yes	Yes	0	5
204	Minimum reference	0.000	-100,000.000-Ref _{MAX}	Yes	Yes	-3	4
205	Maximum reference	1500.000	Ref _{MIN} -100,000.000	Yes	Yes	-3	4
206	Ramp type	Linear		Yes	Yes	0	5
207	Ramp-up time 1	Depends on unit	0.01 - 3600	Yes	Yes	-2	7
208	Ramp-down time 1	Depends on unit	0.01 - 3600	Yes	Yes	-2	7
209	Ramp-up time 2	Depends on unit	0.01 - 3600	Yes	Yes	-2	7
210	Ramp-down time 2	Depends on unit	0.01 - 3600	Yes	Yes	-2	7
211	Jog ramp time	Depends on unit	0.01 - 3600	Yes	Yes	-2	7
212	Quick stop ramp-down time	Depends on unit	0.01 - 3600	Yes	Yes	-2	7
213	Jog speed	200 rpm	0.0 - par. 202	Yes	Yes	-1	6
214	Reference function	Sum		Yes	Yes	0	5
215	Preset reference 1	0.00 %	- 100.00 - 100.00 %	Yes	Yes	-2	3
216	Preset reference 2	0.00 %	- 100.00 - 100.00 %	Yes	Yes	-2	3
217	Preset reference 3	0.00 %	- 100.00 - 100.00 %	Yes	Yes	-2	3
218	Preset reference 4	0.00 %	- 100.00 - 100.00 %	Yes	Yes	-2	3
219	Catch up/slow down value	0.00 %	0.00 - 100 %	Yes	Yes	-2	6
221	Torque limit for motor mode	160 %	0.0 % - xxx %	Yes	Yes	-1	6
222	Torque limit for generating operation	160 %	0.0 % - xxx %	Yes	Yes	-1	6
223	Warning: Low current	0.0 A	0.0 - par. 224	Yes	Yes	-1	6
224	Warning: High current	$I_{VLT,MAX}$	Par. 223 - $I_{VLT,MAX}$	Yes	Yes	-1	6
225	Warning: Low speed	0 rpm	0 - par. 226	Yes	Yes	-1	6
226	Warning: High speed	100.000 rpm	Par. 225 - par. 202	Yes	Yes	-1	6
234	Motor phase monitor	Enable		Yes	Yes	0	5
235	Phase loss monitor	Enable		No	No	0	5
236	Low Speed Current	100%	0 – Motor size depended	Yes	Yes	0	6
237	Model Shift Speed	20% of n_{nom}	10 Hz	Yes	No	0	6
240	Acceleration Jerk 1	33%	0-100%	No	No	0	U16
241	Acceleration Jerk 2	33%	0-100%	No	No	0	U16
242	Deceleration Jerk 1	33%	0-100%	No	No	0	U16
243	Deceleration Jerk 2	33%	0-100%	No	No	0	U16

See also *Operation and Display* for further information regarding Changes during operation, 4-Setup and Conversion index.

PNU #	Parameter description	Factory setting	Range	Changes during operation	4-Setup	Conversion index	Data type
300	Terminal 16, input	Reset		Yes	Yes	0	5
301	Terminal 17, input	Freeze reference		Yes	Yes	0	5
302	Terminal 18 Start, input	Start		Yes	Yes	0	5
303	Terminal 19, input	Reversing		Yes	Yes	0	5
304	Terminal 27, input	Coasting stop, inverse		Yes	Yes	0	5
305	Terminal 29, input	Jog		Yes	Yes	0	5
306	Terminal 32, input	Choice of setup, msb/speed up		Yes	Yes	0	5
307	Terminal 33, input	Choice of setup, lsb/speed down		Yes	Yes	0	5
308	Terminal 53, analogue input voltage	Reference		Yes	Yes	0	5
309	Terminal 53, min. scaling	0.0 V	0.0 - 10.0 V	Yes	Yes	-1	5
310	Terminal 53, max. scaling	10.0 V	0.0 - 10.0 V	Yes	Yes	-1	5
311	Terminal 54, analogue input voltage	No operation		Yes	Yes	0	5
312	Terminal 54, min. scaling	0.0 V	0.0 - 10.0 V	Yes	Yes	-1	5
313	Terminal 54, max. scaling	10.0 V	0.0 - 10.0 V	Yes	Yes	-1	5
314	Terminal 60, analogue input current	Reference		Yes	Yes	0	5
315	Terminal 60, min. scaling	0.0 mA	0.0 - 20.0 mA	Yes	Yes	-4	5
316	Terminal 60, max. scaling	20.0 mA	0.0 - 20.0 mA	Yes	Yes	-4	5
317	Time out	10 sec.	0 - 99 sec.	Yes	Yes	0	5
318	Function after time out	Off		Yes	Yes	0	5
319	Terminal 42, output	0 - n _{MAX} 0-20 mA		Yes	Yes	0	5
321	Terminal 45, output	0 - n _{MAX} 0-20 mA		Yes	Yes	0	5
323	Relay 01, output	No operation		Yes	Yes	0	5
324	Relay 01, ON delay	0.00 sec.	0.00 - 600.00 sec.	Yes	Yes	-2	6
325	Relay 01, OFF delay	0.00 sec.	0.00 - 600.00 sec.	Yes	Yes	-2	6
326	Relay 04, output	No operation		Yes	Yes	0	5
327	Pulse reference, max. frequency	100 - 65000 Hz	5000 Hz	Yes	Yes	0	6
329	Encoder feedback pulse/rev.	1024 pulses/rev.	500 - 10.000 pulses/rev.	Yes	Yes	0	6
341	Terminal 46, digital output	No operation		Yes	Yes	0	5
342	Terminal 46, output, pulse scaling	5000 Hz	1 - 50000 Hz	Yes	Yes	0	6
350	Encoder monitoring	OFF		No	No	0	5
351	Encoder direction	Normal		No	Yes	0	5
355	Terminal 26, digital output	No operation		Yes	Yes	0	5
356	Terminal 26, output, pulse scaling	5000 Hz	1 - 50000 Hz	Yes	Yes	0	6
357	Terminal 42, Output minimum scaling	0 %	000 - 100%	Yes	Yes	0	6
358	Terminal 42, Output maximum scaling	100%	000 - 500%	Yes	Yes	0	6
359	Terminal 45, Output minimum scaling	0 %	000 - 100%	Yes	Yes	0	6
360	Terminal 45, Output maximum scaling	100%	000 - 500%	Yes	Yes	0	6
361	Max Tracking Error	OFF	000 - 999 rpm	Yes	Yes	0	6
362	KTY Sensor Type	KTY1	KTY 1-3	No	Yes	0	5

See also *Operation and Display* for further information regarding Changes during operation, 4-Setup and Conversion index.

PNU #	Parameter description	Factory setting	Range	Changes during operation	4-Setup	Conversion index	Data type
400	Brake function/overvoltage control	Off		Yes	No	0	5
401	Brake resistor, ohm	Depends on the unit		Yes	No	-1	6
402	Brake power limit, kW	Depends on the unit		Yes	No	2	6
403	Power monitoring	Warning		Yes	No	0	5
404	Brake check	Off		Yes	No	0	5
405	Reset function	Manual reset		Yes	Yes	0	5
406	Automatic restart time	5 sec.	0 - 10 sec.	Yes	Yes	0	5
409	Trip delay torque	5 sec.	0 - 60 sec.				
417	Speed PID proportional gain	0.015	0.000 - 5.000	Yes	Yes	-3	6
418	Speed PID integration time	200 ms	2.00 - 20.000 ms	Yes	Yes	-4	7
421	Speed PID low-pass filter	5/20	1-500 ms	Yes	Yes	-4	6
445	Flying start	Disable		Yes	Yes	0	5
458	LC-filter connected	No	0-1	No	Yes	0	5
459	Capacity LC-filter	2 µF	0.1-100 µF	No	Yes	-1	6
460	Inductance LC-filter	7 mH	0.1-100 mH	No	Yes	-1	6
462	Saturation brake	Off	0-100%	Yes	Yes	0	6
463	AEO Cos Phi	0.91 = OFF	0.50-0.91	Yes	Yes	-2	S16
470	Adaptive Gain Scale	100%	20%-500%	Yes	Yes	0	U16
471	Adaptive Gain min speed	50 RPM	0-1500 RPM	Yes	Yes	67	U16
472	Adaptive Gain max speed	50 RPM	0-1500 RPM	Yes	Yes	67	U16

PNU #	Parameter description	Factory setting	Range	Changes during operation	4-Setup	Conversion index	Data type
500	Address	1	1 - 126	Yes	No	0	6
501	Baudrate	9600 Baud		Yes	No	0	5
502	Coasting	Logic or		Yes	Yes	0	5
503	Quick-stop	Logic or		Yes	Yes	0	5
504	DC-brake	Logic or		Yes	Yes	0	5
505	Start	Logic or		Yes	Yes	0	5
506	Reversing	Digital input		Yes	Yes	0	5
507	Selection of setup	Logic or		Yes	Yes	0	5
508	Selection of speed	Logic or		Yes	Yes	0	5
509	Bus jog 1	200 rpm	0.0 - parameter 202	Yes	Yes	-1	6
510	Bus jog 2	200 rpm	0.0 - parameter 202	Yes	Yes	-1	6
512	Telegram profile	FC Drive		No	Yes	0	5
513	Bus time interval	1 sec.	1 - 99 s	Yes	Yes	0	5
514	Bus time interval function	Off		Yes	Yes	0	5
515	Data read-out: Reference %			No	No	-1	3
516	Data read-out: Reference unit			No	No	-3	4
518	Data read-out: Frequency			No	No	-1	6
520	Data read-out: Current			No	No	-2	7
521	Data read-out: Torque			No	No	-1	3
522	Data read-out: Power, kW			No	No	-1	7
523	Data read-out: Power, HP			No	No	-2	7
524	Data read-out: Motor voltage			No	No	-1	6
525	Data read-out: DC link voltage			No	No	0	6
526	Data read-out: Motor temp.			No	No	0	5
527	Data read-out: VLT temp.			No	No	0	5
528	Data read-out: Digital input			No	No	0	5
529	Data read-out: Terminal 53, analogue input			No	No	-2	3
530	Data read-out: Terminal 54, analogue input			No	No	-2	3
531	Data read-out: Terminal 60, analogue input			No	No	-5	3
532	Data read-out: Pulse reference			No	No	-1	7
533	Data read-out: External reference %			No	No	-1	3
534	Data read-out: Status word, binary			No	No	0	6
535	Data read-out: Brake power/2 min.			No	No	2	6
536	Data read-out: Brake power/sec.			No	No	2	6
537	Data read-out: Heat sink temperature			No	No	0	5
538	Data read-out: Alarm word, binary			No	No	0	7
539	Data read-out: VLT control word, binary			No	No	0	6
540	Data read-out: Warning word, 1			No	No	0	7
541	Data read-out: Extended status word			No	No	0	7
557	Data read-out: Motor RPM			No	No	0	4
558	Data read-out: Motor RPM x scaling			No	No	-2	4

PNU #	Parameter description	Factory setting	Range	Changes during operation	4-Setup	Conversion index	Data type
600	Operating data: Operating hours			No	No	74	7
601	Operating data: Hours run			No	No	74	7
602	Operating data: kWh counter			No	No	1	7
603	Operating data: Number of power-up's			No	No	0	6
604	Operating data: Number of overtemperatures			No	No	0	6
605	Operating data: Number of overvoltages			No	No	0	6
606	Data log: Digital input			No	No	0	5
607	Data log: Bus commands			No	No	0	6
608	Data log: Bus status word			No	No	0	6
609	Data log: Reference			No	No	-1	3
611	Data log: Motor frequency			No	No	-1	3
612	Data log: Motor voltage			No	No	-1	6
613	Data log: Motor current			No	No	-2	3
614	Data log: DC link voltage			No	No	0	6
615	Fault log: Error code			No	No	0	5
616	Fault log: Time			No	No	-1	7
617	Fault log: Value			No	No	0	3
618	Reset of kWh counter	No reset		Yes	No	0	5
619	Reset of hours-run counter	No reset		Yes	No	0	5
620	Operating mode Normal function	Normal function		No	No	0	5
621	Nameplate: VLT type			No	No	0	9
622	Nameplate: Power section			No	No	0	9
623	Nameplate: VLT ordering number			No	No	0	9
624	Nameplate: Software version no.			No	No	0	9
625	Nameplate: LCP identification no.			No	No	0	9
626	Nameplate: Database identification no.			No	No	-2	9
627	Nameplate: Power section identification no.			No	No	0	9
628	Nameplate: Application option type			No	No	0	9
629	Nameplate: Application option ordering no.			No	No	0	9
630	Nameplate: Communication option type			No	No	0	9
631	Nameplate: Communication option ordering no.			No	No	0	9
639	Flash Test	Off		Yes	No	0	5

See also *Operation and Display* for further information regarding Changes during operation, 4-Setup and Conversion index.

■ General technical data

Mains supply (L1, L2, L3):

Supply voltage 200-240 V units	3 x 200/208/220/230/240 V ±10%
Supply voltage 380-500 V units	3 x 380/400/415/440/460/500 V ±10%
Supply frequency	48-62 Hz +/- 1%

Max imbalance of supply voltage:

VLT 5001-5011, 380-500 V and VLT 5001-5006, 200-240 V	±2.0% of rated supply voltage
VLT 5016-5062, 380-500 V and VLT 5008-5027, 200-240 V	±1.5% of rated supply voltage
VLT 5072-5502, 380-500 V and VLT 5032-5052, 200-240 V	±3.0% of rated supply voltage
True Power factor (λ)	0.90 nominal at rated load
Displacement Power Factor ($\cos \phi$)	near unity (>0.98)
No. of switchings on supply input L1, L2, L3	approx. 1 time/min.

VLT output data (U, V, W):

Output voltage	0-100% of supply voltage
Output frequency	0 - 132 Hz, 0 - 300 Hz
Rated motor voltage, 200-240 V units	200/208/220/230/240 V
Rated motor voltage, 380-500 V units	380/400/415/440/460/480/500 V
Rated motor frequency	50/60 Hz
Switching on output	Unlimited
Ramp times	0.01-3600 sec.

Torque characteristics:

Starting torque, VLT 5001-5027, 200-240 V and VLT 5001-5302, 380-500 V	160% for 1 min.
Starting torque, VLT 5032-5052, 200-240 V and VLT 5352-5502, 380-500 V	150% for 1 min.
Starting torque	180% for 0.5 sec.
Acceleration torque	100%
Overload torque, VLT 5001-5027, 200-240 V and VLT 5001-5302, 380-500 V	160%
Overload torque, VLT 5032-5052, 200-240 V and VLT 5352-5502, 380-500 V	150%
Arresting torque at 0 rpm (closed loop)	100%

The torque characteristics given are for the frequency converter at the high overload torque level (160%). At the normal overload torque (110%), the values are lower.

Braking at high overload torque level

	Cycle time (s)	Braking duty cycle at 100% torque	Braking duty cycle at over torque (150/160%)
200-240 V			
5001-5027	120	Continuous	40%
5032-5052	300	10%	10%
380-500 V			
5001-5102	120	Continuous	40%
5122-5252	600	Continuous	10%
5302	600	40%	10%
5352-5502	300	10%	10%

Control card, digital inputs:

Number of programmable digital inputs	8
Terminal nos.	16, 17, 18, 19, 27, 29, 32, 33
Terminal number for none programmable digital input	37
Voltage level	0-24 V DC (PNP positive logics)
Voltage level, logical '0'	< 5 V DC

Voltage level, logical '1'	>10 V DC
Maximum voltage on input	28 V DC
Input resistance, R _i (terminals 16, 17, 18, 19, 27, 32, 33)	4 kΩ
Input resistance, R _i (terminal 29)	2 kΩ
Scanning time per input	3 msec.

Reliable galvanic isolation: All digital inputs are galvanically isolated from the supply voltage (PELV). In addition, the digital inputs can be isolated from the other terminals on the control card by connecting an external 24 V DC supply and opening switch 4. See section on Installation of control cables.

Control card, analogue inputs:

No. of programmable analogue voltage inputs/thermistor inputs	2
Terminal nos.	53, 54
Voltage level	0 - ±10 V DC (scalable)
Input resistance, R _i	10 kΩ
No. of programmable analogue current inputs	1
Terminal no.	60
Current range	0/4 - ±20 mA (scalable)
Input resistance, R _i	200 Ω
Resolution	10 bit + sign
Accuracy on input	Max. error 1% of full scale
Scanning time per input	3 msec.
Terminal no. ground	55

Reliable galvanic isolation: All analogue inputs are galvanically isolated from the supply voltage (PELV) as well as other inputs and outputs.

Control card, pulse input:

No. of programmable pulse inputs	1
Terminal no.	29
Max. frequency on terminal 29 (PNP open collector)	20 kHz
Max. frequency on terminal 29 (Push-pull)	65 kHz
Voltage level	0-24 V DC (PNP positive logics)
Voltage level, logical '0'	< 5 V DC
Voltage level, logical '1'	>10 V DC
Maximum voltage on input	28 V DC
Input resistance, R _i	2 kΩ
Scanning time per input	3 msec.
Resolution	10 bit + sign
Accuracy (100-1 kHz), terminal 29	Max. error: 0.5% of full scale
Accuracy (1-65 kHz), terminal 29	Max. error: 0.1% of full scale

Reliable galvanic isolation: All pulse inputs are galvanically isolated from the supply voltage (PELV). In addition, pulse inputs can be isolated from the other terminals on the control card by connecting an external 24 V DC supply and opening switch 4. See section on Control cables.

Control card, encoder input:

No. of programmable encoder input connector	1
Input terminal nos.	73, 74, 75, 76, 77, 78
Voltage level	RS 422/485
Maximum voltage on input	±7 V DC
Input resistance, R _i	140 Ω
Max. input frequency	250 kHz
Supply terminal nos.	47, 49
Supply voltage	5 V
Max. supply current	250 mA

Reliable galvanic isolation: All encoder inputs are galvanically isolated from the supply voltage (PELV). In addition, encoder inputs can be isolated from the other terminals on the control card by connecting an external 24 V DC supply and opening switch 4. See section on Control cables.

Control card, digital/pulse outputs:

No. of programmable digital outputs	2
Terminal nos.	26, 46
Voltage level at digital/pulse output	0 - 24 V DC
Minimum load to ground (terminal 39) at digital/pulse output	600 Ω
Frequency ranges (digital output used as pulse output)	100HZ-50 kHz
Refresh time	3 ms
Accuracy	±0.1% of full range

Galvanic isolation: All digital outputs are galvanically isolated from the supply voltage (PELV) as well as other inputs and outputs.

Control card, analogue outputs:

No. of programmable digital outputs	2
Terminal nos.	42, 45
Current range at analogue output	0/4 - 20 mA
Maximum load to ground (terminal 39) at analogue output	500 Ω
Accuracy of analogue output	Max. error: 1% of full scale
Resolution on analogue output	8 bit

Galvanic isolation: All analogue outputs are galvanically isolated from the supply voltage (PELV) as well as other inputs and outputs.

Control card, 24 V DC supply:

Terminal nos.	12, 13
Max. load (short-circuit protection)	200 mA
Terminal nos. ground	20, 39

Reliable galvanic isolation: The 24 V DC supply is galvanically isolated from the supply voltage (PELV), but has the same potential as the analogue outputs.

Control card, RS 232 / RS 485 serial communication:

RS 232	RJ-11 connector
Terminal nos.	68 (TX+, RX+), 69 (TX-, RX-)

Full galvanic isolation.

Relay outputs:

No. of programmable relay outputs	2
Terminal nos., control card	4-5 (make)
Max. terminal load (AC) on 4-5, control card	50 V AC, 1 A, 60 VA
Max. terminal load (DC-1, IEC847) on 4-5, control card	75 V DC, 0.1 A, 30 W
Max. terminal load (DC-1, IEC947) on 4-5, control card for UL/cUL applications	30 V AC, 1 A / 42.5 V DC, 1 A
Terminal nos., power card	1-3 (break), 1-2 (make)
Max. terminal load (AC) on 1-3, 1-2, power card	240 V AC, 2 A, 60 VA
Max. terminal load (DC-1, IEC947) on 1-3, 1-2, power card	50 V DC, 2 A
Min. terminal load on 1-3, 1-2, power card	24 V DC 10 mA, 24 V AC 100 mA

Brake resistor terminals (only SB, EB, DE and PB units):

Terminal nos.	81, 82
--------------------	--------

External 24 Volt DC supply:

Terminal nos.	35, 36
Voltage range	24 V DC ±15% (max. 37 V DC for 10 sec.)

Max. voltage ripple 2 V DC
 Power consumption 15 W - 50 W (50 W for start-up, 20 msec.)
 Min. pre-fuse 6 Amp
Reliable galvanic isolation: Full galvanic isolation if the external 24 V DC supply is also of the PELV type.

Cable lengths, cross-sections and connectors:

Max. motor cable length, screened cable 150 m
 Max. motor cable length, unscreened cable 300 m
 Max. motor cable length, screened cable VLT 5011 380-500 V 100 m
 Max. brake cable length, screened cable 20 m
 Max. loadsharing cable length, screened cable 25 m from frequency converter to DC bar.
Max. cable cross-section for motor, brake and loadsharing, see Electrical data
 Max. cable cross-section for 24 V external DC supply
 - VLT 5001-5027 200-240 V; VLT 5001-5102 380-500 V 4 mm² /10 AWG
 - VLT 5032-5052 200-240 V; VLT 5122-5502 380-500 V 2.5 mm² /12 AWG
 Max. cross-section for control cables 1.5 mm² /16 AWG
 Max. cross-section for serial communication 1.5 mm² /16 AWG
If UL/cUL is to be complied with, cable with temperature class 60/75°C must be used (VLT 5001 - 5062 380 - 500 V and VLT 5001 - 5027 200 - 240V).
If UL/cUL is to be complied with, cable with temperature class 75°C must be used (VLT 5072 - 5502 380 - 500 V, VLT 5032 - 5052 200 - 240 V).
Connectors are for use of both copper and aluminium cables, unless other is specified.

Accuracy of display readout (parameters 009-012):

Motor current [6] 0-140% load Max. error: ±2.0% of rated output current
 Torque % [7], -100 - 140% load Max. error: ±5% of rated motor size
 Output [8], power HP [9], 0-90% load Max. error: ±5% of rated output

Control characteristics:

Frequency range	0 - 300 Hz
Resolution on output frequency	±0.003 Hz
System response time	3 msec.
Speed, control range (closed loop)	1:1000 of synchro. speed
Speed, accuracy (closed loop)	0,001%
Torque control accuracy (speed feedback)	Max. error ±5% of rated torque

All control characteristics are based on a 4-pole asynchronous motor

Externals:

Enclosure (dependent on power size)	IP 00, IP 20, IP 21, Nema 1, IP 54
Vibration test	0.7 g RMS 18-1000 Hz random. 3 directions for 2 hours (IEC 68-2-34/35/36)
Max. relative humidity	93 % (IEC 68-2-3) for storage/transport
Max. relative humidity	95 % non condensing (IEC 721-3-3; class 3K3) for operation
Aggressive environment (IEC 721 - 3 - 3)	Uncoated class 3C2
Aggressive environment (IEC 721 - 3 - 3)	Coated class 3C3
Ambient temperature IP 20/Nema 1(high overload torque 160%)	Max. 45°C (24-hour average max. 40°C)
Ambient temperature IP 20/Nema 1(normal overload torque 110%)	Max. 40°C (24-hour average max. 35°C)
Ambient temperature IP 54 (high overload torque 160%)	Max. 40°C (24-hour average max. 35°C)
Ambient temperature IP 54 (normal overload torque 110%)	Max. 40°C (24-hour average max. 35°C)
Ambient temperature IP 20/54 VLT 5011 500 V	Max. 40°C (24-hour average max. 35°C)

Derating for high ambient temperature, see the Design Guide

Min. ambient temperature in full operation	0°C
Min. ambient temperature at reduced performance	-10°C
Temperature during storage/transport	-25 - +65/70°C
Max. altitude above sea level	1000 m

Derating for altitude over 1000 m above sealevel, see the Design Guide

EMC standards applied, Emission	EN 61000-6-3, EN 61000-6-4, EN 61800-3, EN 55011
EMC standards applied, Immunity	EN 61000-6-2, EN 61000-4-2, EN 61000-4-3, EN 61000-4-4 EN 61000-4-5, EN 61000-4-6, VDE 0160/1990.12

VLT 5000 Series protection:

- Electronic motor thermal protection against overload.
- Temperature monitoring of heat-sink ensures that the frequency converter cuts out if the temperature reaches 90°C for IP 00, IP 20 and Nema 1. For IP 54, the cut-out temperature is 80°C. An overtemperature can only be reset when the temperature of the heat-sink has fallen below 60°C.

For the units mentioned below, the limits are as follows:

- VLT 5122, 380-500 V, cuts out at 75°C and can be reset if the temperature has fallen below 60°C.
- VLT 5152, 380-500 V, cuts out at 80°C and can be reset if the temperature has fallen below 60°C.
- VLT 5202, 380-500 V, cuts out at 95°C and can be reset if the temperature has fallen below 65°C.
- VLT 5252, 380-500 V, cuts out at 95°C and can be reset if the temperature has fallen below 65°C.
- VLT 5302, 380-500 V, cuts out at 105°C and can be reset if the temperature has fallen below 75°C.
- VLT 5352-5502, 380-500 V, cut out at 85°C and can be reset if the temperature has fallen below 60°C.

- The frequency converter is protected against short-circuiting on motor terminals U, V, W.
- The frequency converter is protected against earth fault on motor terminals U, V, W.
- Monitoring of the intermediate circuit voltage ensures that the frequency converter cuts out if the intermediate circuit voltage becomes too high or too low.
- If a motor phase is missing, the frequency converter cuts out, see parameter *234 Motor phase monitor*.
- If there is a mains fault, the frequency converter is able to carry out a controlled deceleration.
- If a mains phase is missing, the frequency converter will cut out when a load is placed on the motor.

■ Electrical data

■ Bookstyle and Compact, Mains supply 3 x 200 - 240 V

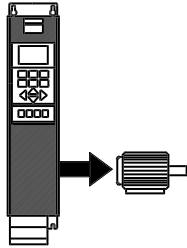
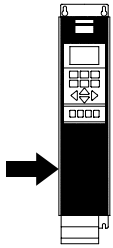
According to international requirements		VLT type	5001	5002	5003	5004	5005	5006
	Output current	I_{MTN} [A]	3.7	5.4	7.8	10.6	12.5	15.2
		$I_{MT MAX}$ (60 s) [A]	5.9	8.6	12.5	17	20	24.3
	Output (240 V)	S_{MTN} [kVA]	1.5	2.2	3.2	4.4	5.2	6.3
	Typical shaft output	P_{VITN} [kW]	0.75	1.1	1.5	2.2	3.0	3.7
	Typical shaft output	P_{VITN} [HP]	1	1.5	2	3	4	5
	Max. cable cross-section to motor, brake and loadsharing [mm ²]/[AWG] ²)		4/10	4/10	4/10	4/10	4/10	4/10
	Rated input current (200 V) I_{IN} [A]		3.4	4.8	7.1	9.5	11.5	14.5
	Max. cable cross-section power [mm ²]/[AWG] ²)		4/10	4/10	4/10	4/10	4/10	4/10
	Max. pre-fuses [-]/UL ¹⁾ [A]		16/10	16/10	16/15	25/20	25/25	35/30
	Efficiency ³⁾		0.95	0.95	0.95	0.95	0.95	0.95
	Weight IP 20 EB	[kg]	7	7	7	9	9	9.5
	Bookstyle							
	Weight IP 20 EB Compact	[kg]	8	8	8	10	10	10
	Weight IP 54 Compact	[kg]	11.5	11.5	11.5	13.5	13.5	13.5
	Power loss at max. load.	[W]	58	76	95	126	172	194
	Enclosure		IP 20/	IP 20/	IP 20/	IP 20/	IP 20/	IP 20/
			IP54	IP54	IP54	IP54	IP54	IP54

1. For type of fuse see section *Fuses*.

2. American Wire Gauge.

3. Measured using 30 m screened motor cables at rated load and rated frequency.

■ Compact, Mains supply 3 x 200 - 240 V

According to international requirements		VLT type	5008	5011	5016	5022	5027
Normal overload torque (110 %):							
Output current	$I_{M,TN}$ [A]		32	46	61.2	73	88
	$I_{VLT, MAX}$ (60 s) [A]		35.2	50.6	67.3	80.3	96.8
Output (240 V)	$S_{VLT,N}$ [kVA]		13.3	19.1	25.4	30.3	36.6
Typical shaft output	$P_{VLT,N}$ [kW]		7.5	11	15	18.5	22
Typical shaft output	$P_{VLT,N}$ [HP]		10	15	20	25	30
High overload torque (160 %):							
Output current	$I_{M,TN}$ [A]		25	32	46	61.2	73
	$I_{VLT, MAX}$ (60 s) [A]		40	51.2	73.6	97.9	116.8
Output (240 V)	$S_{VLT,N}$ [kVA]		10	13	19	25	30
Typical shaft output	$P_{VLT,N}$ [kW]		5.5	7.5	11	15	18.5
Typical shaft output	$P_{VLT,N}$ [HP]		7.5	10	15	20	25
Max. cable cross-section to motor, brake and loadsharing [mm ² /AWG] ²⁾⁵⁾	IP 54		16/6	16/6	35/2	35/2	50/0
Min. cable cross-section to motor, brake and loadsharing ⁴⁾ [mm ² /AWG] ²⁾	IP 20		16/6	35/2	35/2	35/2	50/0
			10/8	10/8	10/8	10/8	16/6
<hr/>							
Rated input current (200 V) $I_{i,N}$ [A]			32	46	61	73	88
Max. cable cross-section, power [mm ² /AWG] ²⁾⁵⁾	IP 54		16/6	16/6	35/2	35/2	50/0
Max. pre-fuses [-]/UL ¹⁾ [A]	IP 20		16/6	35/2	35/2	35/2	50/0
Efficiency ³⁾			0.95	0.95	0.95	0.95	0.95
Weight IP 20 EB [kg]			21	25	27	34	36
Weight IP 54 [kg]			38	40	53	55	56
Power loss at max. load.							
- high overload torque (160 %)	[W]		340	426	626	833	994
- normal overload torque (110 %)	[W]		426	545	783	1042	1243
Enclosure			IP 20/ IP 54	IP 20/ IP 54	IP 20/ IP 54	IP 20/ IP 54	IP 20/ IP 54

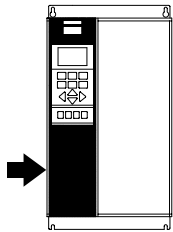
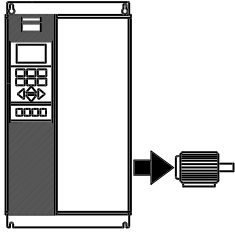

1. For type of fuse see section *Fuses*
2. American Wire Gauge.
3. Measured using 30 m screened motor cables at rated load and rated frequency.
4. Min. cable cross-section is the smallest cable cross-section allowed to be fitted on the terminals to comply with IP 20. Always comply with national and local regulations on min. cable cross-section.
5. Aluminium cables with cross-section above 35 mm² must be connected by use of a Al-Cu connector.

■ Compact, Mains supply 3 x 200 - 240 V

According to international requirements		VLT type	5032	5042	5052
Normal overload torque (110 %):					
Output current	I_{MTN} [A] (200-230 V)		115	143	170
	$I_{MT,MAX}$ (60 s) [A] (200-230 V)		127	158	187
	I_{MTN} [A] (231-240 V)		104	130	154
	$I_{MT,MAX}$ (60 s) [A] (231-240 V)		115	143	170
Output	S_{MTN} [kVA] (208 V)		41	52	61
	S_{MTN} [kVA] (230 V)		46	57	68
	S_{MTN} [kVA] (240 V)		43	54	64
Typical shaft output	[HP] (208 V)		40	50	60
Typical shaft output	[kW] (230 V)		30	37	45
High overload torque (160 %):					
Output current	I_{MTN} [A] (200-230 V)		88	115	143
	$I_{MT,MAX}$ [A] (200-230 V)		132	173	215
	I_{MTN} [A] (231-240 V)		80	104	130
	$I_{MT,MAX}$ [A] (231-240 V)		120	285	195
Output	S_{MTN} [kVA] (208 V)		32	41	52
	S_{MTN} [kVA] (230 V)		35	46	57
	S_{MTN} [kVA] (240 V)		33	43	54
Typical shaft output	[HP] (208 V)		30	40	50
	[kW] (230 V)		22	30	37
Max. cable cross-section to motor and loadsharing	[mm ²] ^{4,6}			120	
	[AWG] ^{2,4,6}			300 mcm	
Max. cable cross-section to brake	[mm ²] ^{4,6}			25	
	[AWG] ^{2,4,6}			4	
Normal overload torque (110 %):					
Rated input current	I_{IN} [A] (230 V)		101.3	126.6	149.9
Normal overload torque (150 %):					
Rated input current	I_{IN} [A] (230 V)		77.9	101.3	126.6
Max. cable cross-section	[mm ²] ^{4,6}			120	
	[AWG] ^{2,4,6}			300 mcm	
power supply	[AWG] ^{2,4,6}			6	
Min. cable cross-section to motor, power	[AWG] ^{2,4,6}			8	
supply, brake and loadsharing					
Max. pre-fuses (mains) [-]/UL	[A] ¹		150/150	200/200	250/250
Efficiency ³			0.96-0.97		
Power loss	Normal overload [W]		1089	1361	1612
	High overload [W]		838	1089	1361
Weight	IP 00 [kg]		101	101	101
Weight	IP 20 Nema1 [kg]		101	101	101
Weight	IP 54 Nema12 [kg]		104	104	104
Enclosure	IP 00 / Nema 1 (IP 20) / IP 54				

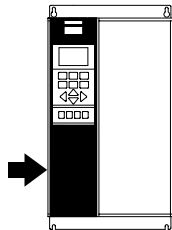
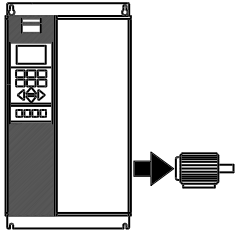

- For type of fuse see section *Fuses*
- American Wire Gauge.
- Measured using 30 m screened motor cables at rated load and rated frequency.
- Max. cable cross-section is the maximum possible cable cross-section allowed to be fitted on the terminals. Min. cable cross-section is the minimum allowed cross-section. Always comply with national and local regulations on min. cable cross-section.
- Weight without shipping container.
- Connection stud: M8 Brake: M6.

■ Bookstyle and Compact, Mains supply 3 x 380 - 500 V

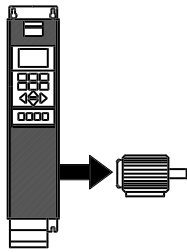
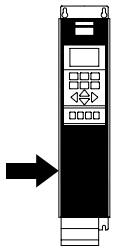
According to international requirements		VLT type	5001	5002	5003	5004	
	Output current	I_{MTN} [A] (380-440 V)	2.2	2.8	4.1	5.6	
		$I_{MT,MAX}$ (60 s) [A] (380-440 V)	3.5	4.5	6.5	9	
	Output	I_{MTN} [A] (441-500 V)	1.9	2.6	3.4	4.8	
		$I_{MT,MAX}$ (60 s) [A] (441-500 V)	3	4.2	5.5	7.7	
		S_{VITN} [kVA] (380-440 V)	1.7	2.1	3.1	4.3	
		S_{VITN} [kVA] (441-500 V)	1.6	2.3	2.9	4.2	
		Typical shaft output	P_{VITN} [kW]	0.75	1.1	1.5	2.2
		Typical shaft output	P_{VITN} [HP]	1	1.5	2	3
	Max. cable cross-section to motor, brake and loadsharing [mm ²]/[AWG] ²)			4/10	4/10	4/10	4/10
		Rated input current	I_{LN} [A] (380 V)	2.3	2.6	3.8	5.3
I_{LN} [A] (460 V)			1.9	2.5	3.4	4.8	
Max. cable cross-section, power [mm ²]/[AWG] ²)			4/10	4/10	4/10	4/10	
Max. pre-fuses [-]/UL ¹) [A]			16/6	16/6	16/10	16/10	
Efficiency ³)			0.96	0.96	0.96	0.96	
Weight IP 20 EB Bookstyle [kg]			7	7	7	7.5	
Weight IP 20 EB Compact [kg]			8	8	8	8.5	
Weight IP 54 Compact [kg]			11.5	11.5	11.5	12	
Power loss at max. load [W]			55	67	92	110	
Enclosure			IP 20/ IP 54	IP 20/ IP 54	IP 20/ IP 54	IP 20/ IP 54	

1. For type of fuse see section *Fuses*.
2. American Wire Gauge.
3. Measured using 30 m screened motor cables at rated load and rated frequency.

Bookstyle and Compact, Mains supply 3 x 380 - 500 V

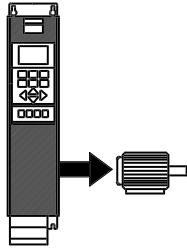
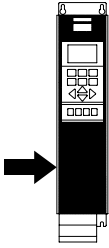
According to international requirements		VLT type	5005	5006	5008	5011	
	Output current	I_{MTN} [A] (380-440 V)	7.2	10	13	16	
		$I_{MT,MAX}$ (60 s) [A] (380-440 V)	11.5	16	20.8	25.6	
	Output	I_{MTN} [A] (441-500 V)	6.3	8.2	11	14.5	
		$I_{MT,MAX}$ (60 s) [A] (441-500 V)	10.1	13.1	17.6	23.2	
		S_{VITN} [kVA] (380-440 V)	5.5	7.6	9.9	12.2	
		S_{VITN} [kVA] (441-500 V)	5.5	7.1	9.5	12.6	
		Typical shaft output	P_{VITN} [kW]	3.0	4.0	5.5	7.5
		Typical shaft output	P_{VITN} [HP]	4	5	7.5	10
		Max. cable cross-section to motor, brake and loadsharing [mm ²]/[AWG] ²)		4/10	4/10	4/10	4/10
			Rated input current	I_{LN} [A] (380 V)	7	9.1	12.2
I_{LN} [A] (460 V)	6			8.3	10.6	14.0	
Max. cable cross-section power [mm ²]/[AWG] ²)			4/10	4/10	4/10	4/10	
Max. pre-fuses [-]/UL ¹) [A]			16/15	25/20	25/25	35/30	
Efficiency ³)			0.96	0.96	0.96	0.96	
Weight IP 20 EB Bookstyle [kg]			7.5	9.5	9.5	9.5	
Weight IP 20 EB Compact [kg]			8.5	10.5	10.5	10.5	
Weight IP 54 EB Compact [kg]			12	14	14	14	
Power loss at max. load.	[W]		139	198	250	295	
Enclosure			IP 20/	IP 20/	IP 20/	IP 20/	
		IP 54	IP 54	IP 54	IP 54		

1. For type of fuse see section *Fuses*.
2. American Wire Gauge.
3. Measured using 30 m screened motor cables at rated load and rated frequency.

■ Compact, Mains supply 3 x 380 - 500 V

According to international requirements		VLT type	5016	5022	5027
Normal overload torque (110 %):					
Output current	I_{MTN} [A] (380-440 V)		32	37.5	44
	$I_{VLT, MAX}$ (60 s) [A] (380-440 V)		35.2	41.3	48.4
Output	$I_{VLT, N}$ [A] (441-500 V)		27.9	34	41.4
	$I_{VLT, MAX}$ (60 s) [A] (441-500 V)		30.7	37.4	45.5
Typical shaft output	S_{MTN} [kVA] (380-440 V)		24.4	28.6	33.5
	$S_{VLT, N}$ [kVA] (441-500 V)		24.2	29.4	35.8
Typical shaft output	$P_{VLT, N}$ [kW]		15	18.5	22
	$P_{VLT, N}$ [HP]		20	25	30
High overload torque (160 %):					
Output current	I_{MTN} [A] (380-440 V)		24	32	37.5
	$I_{VLT, MAX}$ (60 s) [A] (380-440 V)		38.4	51.2	60
Output	$I_{VLT, N}$ [A] (441-500 V)		21.7	27.9	34
	$I_{VLT, MAX}$ (60 s) [A] (441-500 V)		34.7	44.6	54.4
Typical shaft output	S_{MTN} [kVA] (380-440 V)		18.3	24.4	28.6
	$S_{VLT, N}$ [kVA] (441-500 V)		18.8	24.2	29.4
Typical shaft output	$P_{VLT, N}$ [kW]		11	15	18.5
	$P_{VLT, N}$ [HP]		15	20	25
Max. cable cross-section to motor, brake and loadsharing [mm ²]/[AWG] ²	IP 54		16/6	16/6	16/6
	IP 20		16/6	16/6	35/2
Min. cable cross-section to motor, brake and loadsharing [mm ²]/[AWG] ^{2 4}			10/8	10/8	10/8
Rated input current	I_{LN} [A] (380 V)		32	37.5	44
	I_{LN} [A] (460 V)		27.6	34	41
Max. cable cross-section, power [mm ²]/[AWG]	IP 54		16/6	16/6	16/6
	IP 20		16/6	16/6	35/2
Max. pre-fuses	[-]/[UL ¹] [A]		63/40	63/50	63/60
Efficiency ³			0.96	0.96	0.96
Weight IP 20 EB	[kg]		21	22	27
Weight IP 54	[kg]		41	41	42
Power loss at max. load.					
	- high overload torque (160 %)	[W]	419	559	655
	- normal overload torque (110 %)	[W]	559	655	768
Enclosure			IP 20/	IP 20/	IP 20/
			IP 54	IP 54	IP 54

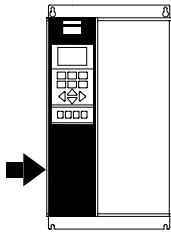
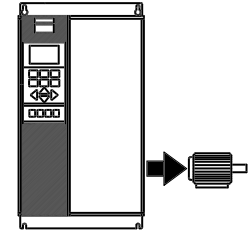

1. For type of fuse see section *Fuses*.
2. American Wire Gauge.
3. Measured using 30 m screened motor cables at rated load and rated frequency.
4. Min. cable cross-section is the smallest cable cross-section allowed to be fitted on the terminals to comply with IP 20. Always comply with national and local regulations on min. cable cross-section.

Compact, Mains supply 3 x 380 - 500 V

According to international requirements

		VLT type	5032	5042	5052
Normal overload torque (110 %):					
Output current	I_{MTN} [A] (380-440 V)		61	73	90
	$I_{VLT, MAX}$ (60 s) [A] (380-440 V)		67.1	80.3	99
Output	$I_{VLT, N}$ [A] (441-500 V)		54	65	78
	$I_{VLT, MAX}$ (60 s) [A] (441-500 V)		59.4	71.5	85.8
Output	S_{MTN} [kVA] (380-440 V)		46.5	55.6	68.6
	$S_{VLT, N}$ [kVA] (441-500 V)		46.8	56.3	67.5
Typical shaft output	$P_{VLT, N}$ [kW]		30	37	45
Typical shaft output	$P_{VLT, N}$ [HP]		40	50	60
High overload torque (160 %):					
Output current	I_{MTN} [A] (380-440 V)		44	61	73
	$I_{VLT, MAX}$ (60 s) [A] (380-440 V)		70.4	97.6	116.8
Output	$I_{VLT, N}$ [A] (441-500 V)		41.4	54	65
	$I_{VLT, MAX}$ (60 s) [A] (441-500 V)		66.2	86	104
Output	S_{MTN} [kVA] (380-440 V)		33.5	46.5	55.6
	$S_{VLT, N}$ [kVA] (441-500 V)		35.9	46.8	56.3
Typical shaft output	$P_{VLT, N}$ [kW]		22	30	37
Typical shaft output	$P_{VLT, N}$ [HP]		30	40	50
Max. cable cross-section to motor, brake and loadsharing [mm ²] / [AWG] ²⁾⁵⁾		IP 54	35/2	35/2	50/0
		IP20	35/2	35/2	50/0
Min. cable cross-section to motor, brake and loadsharing [mm ²] / [AWG] ²⁾⁴⁾			10/8	10/8	16/6
Rated input current	$I_{L, N}$ [A] (380 V)		60	72	89
	$I_{L, N}$ [A] (460 V)		53	64	77
Max. cable cross-section power [mm ²] / [AWG] ²⁾⁵⁾		IP 54	35/2	35/2	50/0
		IP 20	35/2	35/2	50/0
Max. pre-fuses	[-] / UL ¹⁾ [A]		80/80	100/100	125/125
Efficiency ³⁾			0.96	0.96	0.96
Weight IP 20 EB	[kg]		28	41	42
Weight IP 54	[kg]		54	56	56
Power loss at max. load.					
- high overload torque (160 %)	[W]		768	1065	1275
- normal overload torque (110 %)	[W]		1065	1275	1571
Enclosure			IP 20/	IP 20/	IP 20/
			IP 54	IP 54	IP 54

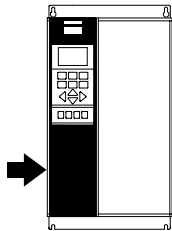
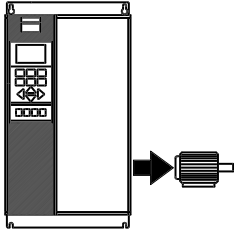

1. For type of fuse see section *Fuses*.

2. American Wire Gauge.

3. Measured using 30 m screened motor cables at rated load and rated frequency.

4. Min. cable cross-section is the smallest cable cross-section allowed to be fitted on the terminals to comply with IP 20. Always comply with national and local regulations on min. cable cross-section.

5. Aluminium cables with cross-section above 35 mm² must be connected by use of a Al-Cu connector.

Compact, Mains supply 3 x 380 - 500 V

According to international requirements		VLT type	5062	5072	5102
Normal overload torque (110 %):					
Output current	$I_{M,T,N}$ [A] (380-440 V)		106	147	177
	$I_{VLT, MAX}$ (60 s) [A] (380-440 V)		117	162	195
Output	$I_{M,T,N}$ [A] (441-500 V)		106	130	160
	$I_{VLT, MAX}$ (60 s) [A] (441-500 V)		117	143	176
	$S_{M,T,N}$ [kVA] (380-440 V)		80.8	102	123
	$S_{VLT,N}$ [kVA] (441-500 V)		91.8	113	139
Typical shaft output	$P_{VLT,N}$ [kW] (400 V)		55	75	90
	$P_{VLT,N}$ [HP] (460 V)		75	100	125
	$P_{VLT,N}$ [kW] (500 V)		75	90	110
High overload torque (160 %):					
Output current	$I_{M,T,N}$ [A] (380-440 V)		90	106	147
	$I_{VLT, MAX}$ (60 s) [A] (380-440 V)		135	159	221
Output	$I_{M,T,N}$ [A] (441-500 V)		80	106	130
	$I_{VLT, MAX}$ (60 s) [A] (441-500 V)		120	159	195
	$S_{M,T,N}$ [kVA] (380-440 V)		68.6	73.0	102
	$S_{VLT,N}$ [kVA] (441-500 V)		69.3	92.0	113
Typical shaft output	$P_{VLT,N}$ [kW] (400 V)		45	55	75
	$P_{VLT,N}$ [HP] (460 V)		60	75	100
	$P_{VLT,N}$ [kW] (500 V)		55	75	90
Max. cable cross-section to motor,	IP 54	50/0 ⁵⁾	150/300	150/300	
brake and loadsharing [mm ²] / [AWG] ²⁾	IP20	50/0 ⁵⁾	mcm ⁶⁾ 120/250	mcm ⁶⁾ 120/250	
Min. cable cross-section to motor,					
brake and loadsharing [mm ²] / [AWG] ⁴⁾			16/6	25/4	25/4
Rated input current	$I_{I, N}$ [A] (380 V)		104	145	174
	$I_{I, N}$ [A] (460 V)		104	128	158
Max. cable cross-section	IP 54	50/0 ⁵⁾	150/300	150/300	
power [mm ²] / [AWG] ²⁾	IP 20	50/0 ⁵⁾	mcm 120/250	mcm 120/250	
Max. pre-fuses	[-] / [UL ¹⁾] [A]		160/150	225/225	250/250
Efficiency ³⁾			>0.97	>0.97	>0.97
Weight IP 20 EB	[kg]		43	54	54
Weight IP 54	[kg]		60	77	77
Power loss at max. load.					
- high overload torque (160 %)	[W]		1122	1058	1467
- normal overload torque (110 %)	[W]		1322	1467	1766
Enclosure			IP20/	IP20/	IP20/
			IP 54	IP 54	IP 54

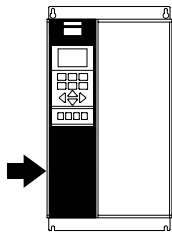
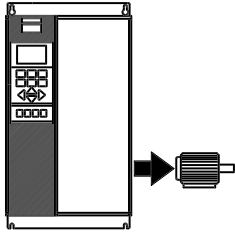

1. For type of fuse see section *Fuses*.
2. American Wire Gauge.
3. Measured using 30 m screened motor cables at rated load and rated frequency.
4. Min. cable cross-section is the smallest cable cross-section allowed to be fitted on the terminals to comply with IP 20. Always comply with national and local regulations on min. cable cross-section.
5. Aluminium cables with cross-section above 35 mm² must be connected by use of a Al-Cu connector used.
6. Brake and loadsharing: 95 mm² / AWG 3/0

■ Compact, Mains supply 3 x 380 - 500 V

According to international requirements		VLT type	5122	5152	5202	5252	5302
Normal overload current (110 %):							
Output current	$I_{M,TN}$ [A] (380-440 V)		212	260	315	395	480
	$I_{VLT, MAX}$ (60 s) [A] (380-440 V)		233	286	347	434	528
	$I_{M,TN}$ [A] (441-500 V)		190	240	302	361	443
	$I_{VLT, MAX}$ (60 s) [A] (441-500 V)		209	264	332	397	487
Output	$S_{M,TN}$ [kVA] (400 V)		147	180	218	274	333
	$S_{M,TN}$ [kVA] (460 V)		151	191	241	288	353
	$S_{M,TN}$ [kVA] (500 V)		165	208	262	313	384
Typical shaft output	[kW] (400 V)		110	132	160	200	250
	[HP] (460 V)		150	200	250	300	350
	[kW] (500 V)		132	160	200	250	315
High overload torque (160 %):							
Output current	$I_{M,TN}$ [A] (380-440 V)		177	212	260	315	395
	$I_{VLT, MAX}$ (60 s) [A] (380-440 V)		266	318	390	473	593
	$I_{M,TN}$ [A] (441-500 V)		160	190	240	302	361
	$I_{VLT, MAX}$ (60 s) [A] (441-500 V)		240	285	360	453	542
Output	$S_{M,TN}$ [kVA] (400 V)		123	147	180	218	274
	$S_{M,TN}$ [kVA] (460 V)		127	151	191	241	288
	$S_{M,TN}$ [kVA] (500 V)		139	165	208	262	313
Typical shaft output	[kW] (400 V)		90	110	132	160	200
	[HP] (460 V)		125	150	200	250	300
	[kW] (500 V)		110	132	160	200	250
Max. cable cross-section to motor	[mm ²] ^{4,6}		2 x 70		2 x 185		
	[AWG] ^{2,4,6}		2 x 2/0		2 x 350 mcm		
Max. cable cross-section to loadsharing and brake	[mm ²] ^{4,6}		2 x 70		2 x 185		
	[AWG] ^{2,4,6}		2 x 2/0		2 x 350 mcm		
Normal overload current (110 %):							
Rated input current	$I_{I,N}$ [A] (380-440 V)		208	256	317	385	467
	$I_{I,N}$ [A] (441-500 V)		185	236	304	356	431
High overload torque (160 %):							
Rated input current	$I_{I,N}$ [A] (380-440 V)		174	206	256	318	389
	$I_{I,N}$ [A] (441-500 V)		158	185	236	304	356
Max. cable cross-section power supply	[mm ²] ^{4,6}		2 x 70		2 x 185		
	[AWG] ^{2,4,6}		2 x 2/0		2 x 350 mcm		
Max. pre-fuses (mains) [-]/UL	[A] ¹		300/	350/	450/	500/	630/
			300	350	400	500	600
Efficiency ³			0,98				
Power loss	Normal overload [W]		2619	3309	4163	4977	6107
	High overload [W]		2206	2619	3309	4163	4977
Weight	IP 00 [kg]		82	91	112	123	138
Weight	IP 21/Nema1 [kg]		96	104	125	136	151
Weight	IP 54/Nema12 [kg]		96	104	125	136	151
Enclosure			IP 00, IP 21/Nema 1 and IP 54/Nema12				

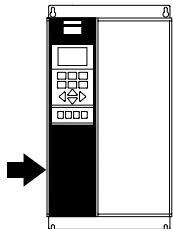
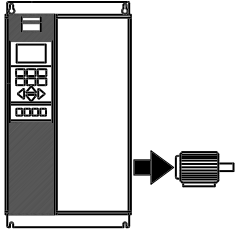

1. For type of fuse see section *Fuses*
2. American Wire Gauge.
3. Measured using 30 m screened motor cables at rated load and rated frequency.
4. Max. cable cross-section is the maximum possible cable cross-section allowed to be fitted on the terminals. Always comply with national and local regulations on min. cable cross-section.
5. Weight without shipping container.
6. Connection bolt power supply and motor: M10; Brake and loadsharing: M8

■ Compact, Mains supply 3 x 380 - 500 V

According to international requirements		VLT type	5352	5452	5502
Normal overload current (110 %):					
Output current	I_{MTN} [A] (380-440 V)		600	658	745
	$I_{MT,MAX}$ (60 s) [A] (380-440 V)		660	724	820
	I_{MTN} [A] (441-500 V)		540	590	678
	$I_{MT,MAX}$ (60 s) [A] (441-500 V)		594	649	746
Output	S_{VITN} [kVA] (400 V)		416	456	516
	S_{VITN} [kVA] (460 V)		430	470	540
	S_{VITN} [kVA] (500 V)		468	511	587
Typical shaft output	[kW] (400 V)		315	355	400
	[HP] (460 V)		450	500	550/600
	[kW] (500 V)		355	400	500
High overload torque (160 %):					
Output current	I_{MTN} [A] (380-440 V)		480	600	658
	$I_{MT,MAX}$ (60 s) [A] (380-440 V)		720	900	987
	I_{MTN} [A] (441-500 V)		443	540	590
	$I_{MT,MAX}$ (60 s) [A] (441-500 V)		665	810	885
Output	S_{VITN} [kVA] (400 V)		333	416	456
	S_{VITN} [kVA] (460 V)		353	430	470
	S_{VITN} [kVA] (500 V)		384	468	511
Typical shaft output	[kW] (400 V)		250	315	355
	[HP] (460 V)		350	450	500
	[kW] (500 V)		315	355	400
Max. cable cross-section	[mm ²] ^{4,6}		4x240		
to motor and loadsharing	[AWG] ^{2,4,6}		4x500 mcm		
Max. cable cross-section	[mm ²] ^{4,6}		2x185		
to brake	[AWG] ^{2,4,6}		2x350 mcm		
Normal overload current (110 %):					
Rated input current	I_{IN} [A] (380-440 V)		590	647	733
	I_{IN} [A] (441-500 V)		531	580	667
High overload torque (160 %):					
Rated input current	I_{IN} [A] (380-440 V)		472	590	647
	I_{IN} [A] (441-500 V)		436	531	580
Max. cable cross-section	[mm ²] ^{4,6}		4x240		
power supply	[AWG] ^{2,4,6}		4x500 mcm		
Max. pre-fuses (mains)	[A] ¹	700/700	900/900	900/900	900/900
[-]/UL					
Efficiency ³			0,98		
Power loss	Normal overload [W]	7630	7701	8879	
	High overload [W]	6005	6960	7691	
Weight	IP 00 [kg]	221	234	236	
Weight	IP 21/Nema1 [kg]	263	270	272	
Weight	IP 54/Nema12 [kg]	263	270	272	
Enclosure	IP 00, IP 21/Nema 1 and IP 54/Nema12				

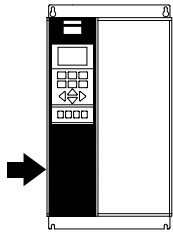
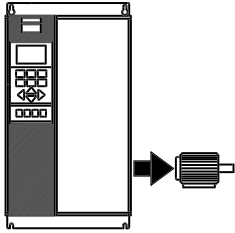

1. For type of fuse see section *Fuses*
2. American Wire Gauge.
3. Measured using 30 m screened motor cables at rated load and rated frequency.
4. Max. cable cross-section is the maximum possible cable cross-section allowed to be fitted on the terminals. Always comply with national and local regulations on min. cable cross-section.
5. Weight without shipping container.
6. Connection bolt power supply, motor and loadsharing: M10 (compression lug), 2xM8 (box lug), M8 (brake)

■ Fuses
UL compliance

To comply with UL/cUL approvals, pre-fuses according to the table below must be used.

200-240 V

VLT	Bussmann	SIBA	Littel fuse	Ferraz-Shawmut
5001	KTN-R10	5017906-010	KLN-R10	ATM-R10 or A2K-10R
5002	KTN-R10	5017906-010	KLN-R10	ATM-R10 or A2K-10R
5003	KTN-R25	5017906-016	KLN-R15	ATM-R15 or A2K-15R
5004	KTN-R20	5017906-020	KLN-R20	ATM-R20 or A2K-20R
5005	KTN-R25	5017906-025	KLN-R25	ATM-R25 or A2K-25R
5006	KTN-R30	5012406-032	KLN-R30	ATM-R30 or A2K-30R
5008	KTN-R50	5014006-050	KLN-R50	A2K-50R
5011	KTN-R60	5014006-063	KLN-R60	A2K-60R
5016	KTN-R85	5014006-080	KLN-R80	A2K-80R
5022	KTN-R125	2028220-125	KLN-R125	A2K-125R
5027	KTN-R125	2028220-125	KLN-R125	A2K-125R
5032	KTN-R150	2028220-160	L25S-150	A25X-150
5042	KTN-R200	2028220-200	L25S-200	A25X-200
5052	KTN-R250	2028220-250	L25S-250	A25X-250

380-500 V

	Bussmann	SIBA	Littel fuse	Ferraz-Shawmut
5001	KTS-R6	5017906-006	KLS-R6	ATM-R6 or A6K-6R
5002	KTS-R6	5017906-006	KLS-R6	ATM-R6 or A6K-6R
5003	KTS-R10	5017906-010	KLS-R10	ATM-R10 or A6K-10R
5004	KTS-R10	5017906-010	KLS-R10	ATM-R10 or A6K-10R
5005	KTS-R15	5017906-016	KLS-R16	ATM-R16 or A6K-16R
5006	KTS-R20	5017906-020	KLS-R20	ATM-R20 or A6K-20R
5008	KTS-R25	5017906-025	KLS-R25	ATM-R25 or A6K-25R
5011	KTS-R30	5012406-032	KLS-R30	A6K-30R
5016	KTS-R40	5012406-040	KLS-R40	A6K-40R
5022	KTS-R50	5014006-050	KLS-R50	A6K-50R
5027	KTS-R60	5014006-063	KLS-R60	A6K-60R
5032	KTS-R80	2028220-100	KLS-R80	A6K-180R
5042	KTS-R100	2028220-125	KLS-R100	A6K-100R
5052	KTS-R125	2028220-125	KLS-R125	A6K-125R
5062	KTS-R150	2028220-160	KLS-R150	A6K-150R
5072	FWH-220	2028220-200	L50S-225	A50-P225
5102	FWH-250	2028220-250	L50S-250	A50-P250
5122*	FWH-300	2028220-315	L50S-300	A50-P300
5152*	FWH-350	2028220-315	L50S-350	A50-P350
5202*	FWH-400	206xx32-400	L50S-400	A50-P400
5252*	FWH-500	206xx32-500	L50S-500	A50-P500
5302*	FWH-600	206xx32-600	L50S-600	A50-P600
5352	170M4017			
5452	170M6013			
5502	170M6013			

* Circuit Breakers manufactured by General Electric, Cat. No. SKHA36AT0800, with rating plugs listed below can be used to meet UL-requirements:

5122	rating plug No.	SRPK800 A 300
5152	rating plug No.	SRPK800 A 400
5202	rating plug No.	SRPK800 A 400
5252	rating plug No.	SRPK800 A 500
5302	rating plug No.	SRPK800 A 600

KTS-fuses from Bussmann may substitute KTN for 240 V drives.
 FWH-fuses from Bussmann may substitute FWX for 240 V drives.

KLSR fuses from LITTEL FUSE may substitute KLNK fuses for 240 V drives.
 L50S fuses from LITTEL FUSE may substitute L50S fuses for 240 V drives.

A6KR fuses from FERRAZ SHAWMUT may substitute A2KR for 240 V drives.
 A50X fuses from FERRAZ SHAWMUT may substitute A25X for 240 V drives.

Non UL compliance

If UL/cUL is not to be complied with, we recommend the above mentioned fuses or:

VLT 5001-5027	200-240 V	type gG
VLT 5032-5052	200-240 V	type gR
VLT 5001-5062	380-500 V	type gG
VLT 5072-5102	380-500 V	type gR
VLT 5122-5302	380-500 V	type gG
VLT 5352-5502	380-500 V	type gR
VLT 5001-5062	525-600 V	type gG

Not following the recommendation may result in unnecessary damage of the drive in case of malfunction. Fuses must be designed for protection in a circuit capable of supplying a maximum of 100000 A_{rms} (symmetrical), 500/600 V maximum.

■ Index
A

Automatic motor adaptation	71
Accuracy of display readout (parameters 009-012)	143
Address	111
Advanced VLT Protection	9
Alarm word	64
AMA	71
Analogue Input	93, 94, 95
Analogue input 53	64
Analogue input 54	64
Analogue input 60	64
Analogue inputs	93
Analogue Outputs	96
Application option	120
Automatic Motor Adaptation, AMA	57
Automatic reset	106

B

Baudrate	111
Both directions,	81
Brake check	105
Brake power	55
Brake power/sec	64
Brake resistor	104, 142
Braking time	55
Bus time interval	112

C

cable clamps	36
control cables	36
Cable clamp	40
Cable lengths	143
Capacity LC-Filter	108
Catch spinning motor,	107
Catch up	85, 85
Change of group of numeric data values	48
Change of numeric data value	48
Changing a text value	48
Changing data	48
Clockwise,	81
Coasting	73, 90, 111
Coasting	72
Communication option	120
Communication option card warning	64
Configuration	69
Configuration	69
Control Cables	30
Control card, 24 V DC supply	142
Control card, analogue inputs	141
Control card, analogue outputs:	142, 142

Control card, digital inputs:	140, 140
Control card, digital/pulse outputs:	142
Control card, digital/pulse outputs:	142
Control card, encoder input:	141, 141
Control card, pulse input:	141
Control card, pulse/encoder input:	141
Control card, RS 232 / RS 485 serial communication:	142
Control card, RS 232/RS 485 serial communication	142
Control characteristics	144
Control keys	44
Control Principle	8
Control word	64
Controlled ramp-down	106
Cooling	16, 18

D

Data change	65
Data value, step-by-step	48
DC brake	73
DC brake	72
DC brake current	73
DC brake cut-in speed	74
DC braking	90, 90
DC braking time	73
DC hold	72
DC holding	73
DC link voltage	64
DC-brake	111
Digital and relay outputs	97
Digital input	64
Digital Input Functions	90
Digital Output	64
DIP Switches 1-4	33
Direction	81
Display	44
Display line 2	63
Display mode	45
Display read-out state	45
Display scaling speed	63
Dynamic brake	104
Dynamic brake function	55

E

Earth leakage current	23
earthing	40
Electrical installation	19, 32
Electrical installation - 24 Volt external DC supply	22
Electrical installation - brake cable	20
Electrical installation - brake resistor temperature switch	20
Electrical installation - earthing of control cables	40
Electrical installation - EMC precautions	36
Electrical installation - external fan supply	22

Electrical installation - mains supply	19
Electrical installation - relay outputs	22
Electrical installation, power cables	24, 25
Enclosure type	16
Encoder direction.....	100
Encoder feedback.....	99
Encoder monitor.....	100
Encoder pulses	100
Equalising cable.....	40
ETR	74
ETR (Electronic Terminal Relay)	74
Ext. Status Word	64
External 24 V DC supply.....	22, 142
External motor fan.....	74
External reference	64
Externals.....	144

F

Fault log: Error code.....	118
Fault log: Time	118
Fault log: Value.....	118
Feedback System	31
Fixed references	85
Flash Test.....	120
Flux Vector	8
Flux Vector Control Principle.....	8
Flying start	59, 107
Freeze output.....	91
Freeze reference	91
Frequency.....	63
Frequency converter	5
Function after time out	95
Function at stop	72
Fuses.....	156

G

Galvanic Isolation	9
General technical data	140
General warning	4

H

Heat sink temp.....	64
High current.....	86
high starting torque	72
Hours run.....	64
High voltage test.....	19
High-Constant Torque.....	69

I

IT mains.....	41
---------------	----

Incremental encoder	31
Indexed parameters	48
Inductance LC-Filter	108
Initial current	75
Initialisation.....	119
Initialisation to factory setting	48
Input	5
Installation of mechanical brake.....	4
Intermediate circuit	8
Iron loss Resistance	77

J

Jog.....	91
Jog ramp time.....	83, 83
Jog speed.....	83, 83

K

KTY sensor	64
Key Diagram.....	10, 11, 12
Kinetic back-up	106
Kinetic back-up and trip	106
KTY Sensor	93
KWh counter	118
kWh counter,	117

L

LCP.....	44
Low current	86
Language.....	61
Latched start	91
LC-filter	108
LC-Filter connected.....	108
LCP copy.....	62
LCP identification.....	119
LEDs.....	44
List of warnings and alarms.....	125
Loadsharing	20
Local and remote control	50
Local jog	65
Local Operation Mode	64
Local reference.....	61
Local reversing	65
Local stop	65
Local/remote control.....	61
Low current	86

M

motor phases.....	87
Main Reactance	76
Mains failure	106

Mains failure	92
Mains fault	108
Mains Interference.....	8
Mains supply	146
Mains supply (L1, L2, L3):	140
Max motor speed	81
Maximum Inertia	77
Maximum reference.....	82, 82
Mechanical brake.....	86
Mechanical dimensions	13
Mechanical installation	16
Menu mode	47
Minimum Intertia	77
Minimum reference.....	81, 81
Minor Interference on Mains	8
Miscellaneous	6
Moment of inertia.....	76
Motor.....	6
Motor cables	36
Motor connection	19
Motor current.....	86, 87
Motor current	63
Motor frequency	70
Motor Parameters.....	76
Motor power.....	69
Motor Protection.....	9, 19
Motor shaft direction.....	19
Motor thermal protection	19
Motor voltage.....	64
Multi-references.....	53

N

Nameplate data.....	69, 70
Normal-constant torque	69
Normal/high overload torque control.....	59

O

Operating hours.....	117
Operating mode	119
Operation mode	119
Output	5
Output speed range/Direction.....	81
Output speed.....	81
Overvoltage control	104

P

proportional gain.....	107
Parameter groups	47
Parameter setup keys:	44
Phase loss	87
Phase Loss Monitor.....	87
PLC.....	40

Pole number	77, 77
Potentiometer reference	35
Power	63, 63
Power monitoring.....	105
Power up	66
Pre-heat	73
Pre-magnetizing	72
Preset reference	85
Preset reference, on	91
Programmable Signal Outputs	8
Programming Setup	62
Pulse reference	64, 92
Pulse start/stop	34

Q

Quick menu mode	46
Quick Menu parameter.....	47
Quick menu, userdefined	66
Quick Setup via Quick menu	47
Quick stop	83
Quick-stop	90, 90, 111

R

ramp-up time	82
Reference	63, 81
reset	105
Ramp 2	92
Ramp type	82
Ramp type,	82
Ramp-down time.....	82, 82
Ramp-down time.	83
Ramp-up time.....	82
Rated motor speed	70
RCD	23
Read-outstate	46
Reference	63, 93
Reference function	83
References	6, 83, 85
Relay outputs:.....	142, 142
Reset	90, 90
Reversing.....	91, 112
RFI switch	41
Rotor Leakage Reactance	76
Rotor resistance	76
RS 232.....	33
RS 485.....	32

S

Safety earthing	19
Safety regulations	4
Saturation brake	108
Scaling	100

Selection of 55
 Selection of Setup.....111
 Selection of speed111
 serial communication 40
 Setup 62, 92
 Setup change 34
 Setup LSB and MSB 92
 single references. 94, 95
 Single references 51
 Slow down 85
 Software version 3, 119
 Speed 63, 87
 Speed control, closed loop 69
 Speed Filter Time.....107
 Speed integral time107
 Speed PI lowpass filter time107
 Speed PID107
 Speed Proportional gain107
 Speed up/down 34
 Start91, 111
 Start delay..... 72
 Start function 72
 Start speed 74
 Starting torque 71
 Stator Leakage Reactance..... 76
 Stator resistance..... 76
 Status messages122
 Status messages. 46
 Stop 91
 Stop at torque limit..... 54
 Switch NO/NC 5

T

Thermal load, VLT 64
 thermistor 74
 Telegram profile112
 Terminal 37..... 31
 Terminal designation 19
 Thermal load, motor 64
 Thermistor..... 93
 Tightening-up torques and screw sizes 20
 Time out 95
 Time-out..... 95
 Torque..... 63
 Torque characteristics69, 140
 Torque control, speed feedback 69
 Torque limit..... 93
 Torque limit 85
 Torque limit for generating operation 86
 Torque limit for motor mode 85
 Trouble-shooting.....121
 Two-wire transmitter 35

U

Unintended start 4
 Unit data.....119
 Use of emc-correct cables 39

V

VLT 5000 Series protection: 144, 144
 VLT ordering number,119
 VLT output data (U, V, W).....140
 VLT type,119
 Voltage level108

W

Warning 86
 Warning against unintended start..... 4
 Warning word 64
 Warning word 1, Extended status word and Alarm word131
 Warnings126

2

2-wire start/stop 34