

■ Contents

Introduction	4
Software version	4
Definitions	5
Safety regulations	7
Warning against unintended start	7
Introduction to Operating Instructions	9
Control principle	10
AEO - Automatic Energy Optimization	11
Example of application - Constant pressure regulation in water supply system	12
PC software and serial communication	13
PC Software tools	13
Fieldbus options	13
Profibus	13
LON - Local Operating Network	13
DeviceNet	14
Modbus RTU	14
Cascade Controller Option	17
Unpacking and ordering a VLT frequency converter	25
Type code ordering number string	25
TYPE CODE Table/Ordering form	29
Installation	30
General technical data	30
Technical data, mains supply 3 x 200 - 240 V	35
Technical data, mains supply 3 x 380 - 480 V	37
Technical data, mains supply 3 x 525 - 600 V	42
Fuses	46
Mechanical dimensions	49
Mechanical installation	52
IP 00 VLT 8450-8600 380-480 V	53
General information about electrical installation	54
High voltage warning	54
Earthing	54
Cables	54
Screened/armoured cables	54
Extra protection with regard to indirect contact	55
RFI switch	56
High voltage test	58
Heat emission from VLT 8000 AQUA	58
EMC-correct electrical installation	59
Earthing/Grounding of screened/armoured control cables	61
Electrical installation, enclosures	62
Use of emc-correct cables	70
Tightening torque and screw sizes	71
Mains connection	72
Motor connection	72
DC bus connection	73
High-voltage relay	74
Electrical installation, control cables	74
Switches 1-4	75
Connection example VLT 8000 AQUA	77

Control unit LCP	80
Control keys for parameter setup	80
Indicator lamps	81
Local control	81
Display mode	81
Navigation between display modes	84
Changing data	85
Manual initialisation	85
Quick Menu	86
Programming	88
Operation and Display 001-017	88
The Setup configuration	88
Setup of user-defined readout	89
Load and motor 100-124	95
Configuration	95
Motor power factor (Cos ϕ)	101
References and limits 200-228	104
Reference handling	105
Reference type	108
Initial ramp parameter 229	112
Fill Mode	112
Fill Rate parameter 230	113
Filled Setpoint parameter 231	113
Inputs and outputs 300-328	114
Analogue inputs	117
Analogue/digital outputs	120
Relay outputs	123
Application functions 400-434	126
Sleep mode	127
PID for process control	132
PID overview	134
Feedback handling	134
Serial communication for FC protocol	140
Protocols	140
Telegram communication	140
Telegram build-up under FC protocol	140
Data character (byte)	141
Process word	144
Control word according to FC protocol	145
Status word according to FC protocol	146
Serial communication 500-556	149
Warning words 1+2 and Alarm word	158
Service functions 600-631	159
Electrical installation of the relay card	164
All about VLT 8000 AQUA	165
Status messages	165
List of warnings and alarms	167
Special conditions	172
Aggressive environments	172
Calculation of resulting reference	173
Extreme running conditions	175
Peak voltage on motor	176

Derating for ambient temperature	178
Switching on the input	178
Efficiency	180
Mains supply interference/harmonics	181
CE labelling	182
EMC test results (Emission, Immunity)	183
EMC Immunity	185
Factory settings	187
Index	195

VLT 8000 AQUA

Operating Instructions
Software version: 1.5x



These Operating Instructions can be used for all VLT 8000 AQUA frequency converters with software version 1.5x.
The software version number can be seen from parameter 624 *Software version no.*

176FA145.13

■ Definitions

Definitions are given in alphabetical order.

AEO:

Automatic Energy Optimization - function that dynamically adjusts the current supplied to a variable torque load to optimize motor power factor and motor efficiency.

Analogue inputs:

The analogue inputs can be used for controlling various functions of the frequency converter.

There are two types of analogue inputs:

Current input, 0-20 mA

Voltage input, 0-10 V DC.

Analogue ref.

A signal transmitted to input 53, 54 or 60.

Can be voltage or current.

Analogue outputs:

There are two analogue outputs, which are able to supply a signal of 0-20 mA, 4-20 mA or a digital signal.

Automatic motor adjustment, AMA:

Automatic motor adjustment algorithm, which determines the electrical parameters for the connected motor, at standstill.

AWG:

AWG means American Wire Gauge, i.e. the American measuring unit for cable cross-section.

Control command:

By means of the control unit and the digital inputs, it is possible to start and stop the connected motor.

Functions are divided into two groups, with the following priorities:

- Group 1 Reset, Coasting stop, Reset and Coasting stop, DC braking, Stop and the [OFF/ STOP] key.
- Group 2 Start, Pulse start, Reversing, Start reversing, Jog and Freeze output

Group 1 functions are called Start-disable commands. The difference between group 1 and group 2 is that in group 1 all stop signals must be cancelled for the motor to start. The motor can then be started by means of a single start signal in group 2.

A stop command given as a group 1 command results in the display indication STOP.

A missing stop command given as a group 2 command results in the display indication STAND BY.

CT:

Constant torque: used for e.g. heavy, solid sludge pumps and centrifuges.

Digital inputs:

The digital inputs can be used for controlling various functions of the frequency converter.

Digital outputs:

There are four digital outputs, two of which activate a relay switch. The outputs are able to supply a 24 V DC (max. 40 mA) signal.

f_{JOG}

The output frequency from the frequency converter transmitted to the motor when the jog function is activated (via digital terminals or serial communication).

f_M

The output frequency from the frequency converter transmitted to the motor.

f_{M,N}

The rated motor frequency (nameplate data).

f_{MAX}

Maximum output frequency transmitted to the motor.

f_{MIN}

Minimum output frequency transmitted to the motor.

I_M

The current transmitted to the motor.

I_{M,N}

The rated motor current (nameplate data).

Initializing:

If initializing is carried out (see parameter 620 *Operating mode*), the frequency converter returns to the factory setting.

I_{VLT,MAX}

The maximum output current.

I_{VLT,N}

The rated output current supplied by the frequency converter.

LCP:

The control panel, which makes up a complete interface for control and programming of VLT 8000 AQUA. The control panel is detachable and may, as an alternative, be installed up to 3 metres away

from the frequency converter, i.e. in a front panel, by means of the installation kit option.

LSB:

Least significant bit.

Used in serial communication.

MCM:

Stands for Mille Circular Mil, an American measuring unit for cable cross-section.

MSB:

Most significant bit.

Used in serial communication.

$n_{M,N}$

The rated motor speed (nameplate data).

η_{VLT}

The efficiency of the frequency converter is defined as the ratio between the power output and the power input.

On-line/off-line parameters:

On-line parameters are activated immediately after the data value is changed. Off-line parameters are not activated until OK has been entered on the control unit.

PID:

The PID regulator maintains the desired speed (pressure, temperature, etc.) by adjusting the output frequency to match the varying load.

$P_{M,N}$

The rated power delivered by the motor (nameplate data).

Preset ref.

A permanently defined reference, which can be set from -100% to +100% of the reference range.

There are four preset references, which can be selected via the digital terminals.

Ref_{MAX}

The maximum value which the reference signal may have. Set in parameter 205 *Maximum reference*, Ref_{MAX} .

Ref_{MIN}

The smallest value which the reference signal may have. Set in parameter 204 *Minimum reference*, Ref_{MIN} .

Setup:

There are four Setups, in which it is possible to save parameter settings. It is possible to change between the four parameter Setups and to edit one Setup, while another Setup is active.

Start-disable command:

A stop command that belongs to group 1 of the control commands - see this group.

Stop command:

See Control commands.

Thermistor:

A temperature-dependent resistor placed where the temperature is to be monitored (VLT or motor).

Trip:

A state which occurs in different situations, e.g. if the frequency converter is subjected to an over-temperature. A trip can be cancelled by pressing reset or, in some cases, automatically.

Trip locked:

Trip locked is a state which occurs in different situations, e.g. if the frequency converter is subject to an over-temperature. A locked trip can be cancelled by cutting off mains and restarting the frequency converter.

U_M

The voltage transmitted to the motor.

$U_{M,N}$

The rated motor voltage (nameplate data).

$U_{VLT, MAX}$

The maximum output voltage.

VT characteristics:

Variable torque characteristics, used for pumps and fans.



The voltage of the frequency converter is dangerous whenever the equipment is connected to mains. Incorrect installation of the motor or the frequency converter may cause damage to the equipment, serious personal injury or death. Consequently, the instructions in this manual, as well as national and local rules and safety regulations, must be complied with.

■ Safety regulations

1. The frequency converter must be disconnected from the mains if repair work is to be carried out. Check that the mains supply has been disconnected and that the necessary time has passed before removing motor and mains plugs.
2. The [OFF/STOP] key on the control panel of the frequency converter does not disconnect the equipment from mains and is thus not to be used as a safety switch.
3. Correct protective earthing/grounding of the equipment must be established, the user must be protected against supply voltage, and the motor must be protected against overload in accordance with the National Electrical Code and local codes.
4. The earth leakage currents are higher than 3.5mA.
5. Protection against motor overload is not included in the factory setting. If this function is required, set parameter 117, *Motor thermal protection*, to data value ETR trip or data value ETR warning.
Note: The function is initialised at 1.0 x rated motor current and rated motor frequency (see parameter 117, *Motor thermal protection*). In UL/cUL

applications ETR provides Class 20, over-load protection in accordance with the NEC®.

6. Do not remove the plugs for the motor and mains supply while the frequency converter is connected to mains. Check that the mains supply has been disconnected and that the necessary time has passed before removing motor and mains plugs.
7. Please note that the frequency converter has more voltage inputs than L1, L2, L3 when the DC-bus terminals or AUX 24 V option are used. Check that all voltage inputs have been disconnected and that the necessary time has passed before repair work is commenced.

■ Warning against unintended start

1. The motor can be brought to a stop by means of digital commands, bus commands, references or a local stop, while the frequency converter is connected to mains. If personal safety considerations make it necessary to ensure that no unintended start occurs, these stop functions are not sufficient.
2. While parameters are being changed, the motor may start. Consequently, the stop key [OFF/STOP] must always be activated, following which data can be modified.
3. A stopped motor may start if a fault occurs in the electronics of the frequency converter, or if a temporary overload or a fault in the supply mains or the motor connection ceases.

Warning:

Touching the electrical parts may be fatal - even after the equipment has been disconnected from line.

VLT 8006-8062, 200-240 V:	wait at least 15 minutes
VLT 8006-8072, 380-480 V:	wait at least 15 minutes
VLT 8102-8352, 380-480 V:	wait at least 20 minutes
VLT 8450-8600, 380-480 V:	wait at least 15 minutes
VLT 8002-8006, 525-600 V:	wait at least 4 minutes
VLT 8008-8027, 525-600 V:	wait at least 15 minutes
VLT 8032-8072, 525-600 V:	wait at least 30 minutes
VLT 8052-8402, 525-690 V:	wait at least 20 minutes

176FA159.13

■ Use on isolated mains

See section *RFI Switch* regarding use on isolated mains.

It is important to follow the recommendations regarding installation on IT-mains, since sufficient protection of the complete installation must be

observed. Not taking care using relevant monitoring devices for IT-mains may result in damage.



It is the responsibility of the user or the person installing the VLT to provide proper earthing/grounding, as well as motor overload and branch circuit protection according to local codes such as the Nation Electrical Code (NEC).



NB!:

Electrostatic Precaution; Electrostatic discharge (ESD). Many electronic components are sensitive to static electricity. Voltages so low that they cannot be felt, seen or heard, can reduce the life, affect performance, or completely destroy sensitive electronic components. When performing service, proper ESD equipment should be used to prevent possible damage from occurring.



The frequency converter contains dangerous voltages when connected to mains voltage. After disconnecting from mains wait at least

- 15 minutes for VLT 8006-8062, 200-240 V
- 15 minutes for VLT 8006-8072, 380-480 V
- 20 minutes for VLT 8102-8352, 380-480 V
- 15 minutes for VLT 8450-8600, 380-480 V
- 4 minutes for VLT 8002-8006, 525-600 V
- 15 minutes for VLT 8008-8027, 525-600 V
- 30 minutes for VLT 8032-8072, 525-600 V
- 20 minutes for VLT 8052-8402, 525-690 V

before touching any electrical components. Also make sure that other voltage inputs have been disconnected, such as external 24 VDC and load-sharing (linkage of DC intermediate circuit). Only a competent electrician should carry out the electrical installation. Improper installation of the motor or the VLT may cause equipment failure, serious injury or death. Follow this manual and National Electrical Codes (NEC) and local safety codes.

■ Introduction to Operating Instructions

These Operating Instructions are divided into four sections with information about VLT 8000 AQUA.

- Introduction to AQUA: This section tells you the advantages you can obtain by using a VLT 8000 AQUA - such as Automatic Energy Optimization, Constant Torque or Variable Torque and other AQUA relevant functions. This section also contains examples of applications as well as information about Danfoss.
- Installation: This section tells you how to carry out a mechanically correct installation of the VLT 8000 AQUA. Furthermore, a list is given of mains and motor connections, together with a description of the control card terminals.
- Programming: This section describes the control unit and the software parameters for the VLT 8000 AQUA. Also included is a guide to the Quick Setup menu, which allows you to get started on your application very quickly.
- All about VLT 8000 AQUA: This section gives information about status, warning and error messages from the VLT 8000 AQUA. Additionally, information is given on technical data, ser-vice, factory settings and special conditions.



NB!:

Indicates something to be noted by the reader.



Indicates a general warning



Indicates a high-voltage warning

■ Control principle

A frequency converter rectifies AC voltage from mains into DC voltage, after which this DC voltage is converted into a AC current with a variable amplitude and frequency.

The motor is thus supplied with variable voltage and frequency, which enables infinitely variable speed control of three-phased, standard AC motors.

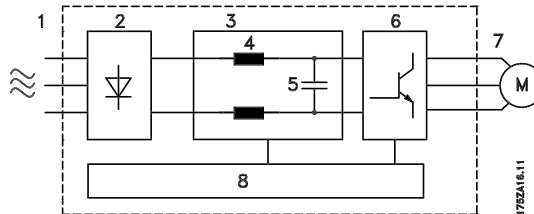

1. Mains voltage

- 3 x 200 - 240 V AC, 50 / 60 Hz.
- 3 x 380 - 480 V AC, 50 / 60 Hz.
- 3 x 525 - 600 V AC, 50 / 60 Hz.
- 3 x 525 - 690 V AC, 50 / 60 Hz.

2. Rectifier

A three-phase rectifier bridge that rectifies AC current into DC current.

3. Intermediate circuit

DC voltage = 1.35 x mains voltage [V].

4. Intermediate circuit coils

Even out the intermediate circuit voltage and reduce the harmonic current feedback to the mains supply.

5. Intermediate circuit capacitors

Even out the intermediate circuit voltage.

6. Inverter

Converts DC voltage into variable AC voltage with a variable frequency.

7. Motor voltage

Variable AC voltage, 0-100% of mains supply voltage.

8. Control card

This is where to find the computer that controls the inverter which generates the pulse pattern by which the DC voltage is converted into variable AC voltage with a variable frequency.

■ **AEO - Automatic Energy Optimization**

Normally, the U/f characteristics have to be set on the basis of the expected load at different frequencies. However, knowing the load at a given frequency in an installation is often a problem. This problem can be solved by using a VLT 8000 AQUA with its integral Automatic Energy Optimization (AEO), which ensures optimum energy utilization. All VLT 8000 AQUA units feature this function as a factory setting, i.e. it is not necessary to adjust the frequency converter U/f ratio in order to obtain maximum energy savings. In other frequency converters, the given load and voltage/frequency ratio (U/f) must be assessed to carry out correct setting of the frequency converter. Using Automatic Energy Optimization (AEO), you no longer need to calculate or assess the system characteristics of the installation, since Danfoss VLT 8000 AQUA units guarantee optimum, load-dependent energy consumption by the motor at all times.

The figure on the right illustrates the working range of the AEO function, within which energy optimization is enabled.

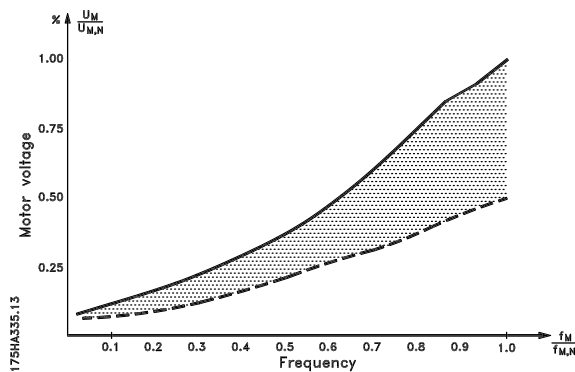

If the AEO function has been selected in parameter 101, *Torque characteristics*, this function will be constantly active. If there is a major deviation from the optimum U/f ratio, the frequency converter will quickly adjust itself.

Advantages of the AEO function

- Automatic energy optimization
- Compensation if an oversize motor is used
- AEO matches operations to daily or seasonal fluctuations
- Energy savings in a constant air volume system
- Compensation in the oversynchronous working range
- Reduces acoustic motor noise

■ Example of application - Constant pressure regulation in water supply system

The demand for water from waterworks varies considerably during the course of a day. In the night, practically no water is used, while in the morning and in the evening the consumption is high. In order to maintain a suitable pressure in the water supply lines in relation to the current demand, the water supply pumps are equipped with speed control. The use of a frequency converter enables the energy consumed by the pumps to be kept at a minimum, while optimizing the water supply to consumers.

A VLT 8000 AQUA with its integral PID controller ensures simple and quick installation. For example, an IP54/NEMA 12 unit can be mounted close to the pump on the wall and the existing mains cables can be used as mains supply to the frequency converter. A Pressure transmitter (e.g. Danfoss MBS 33 or MBS 3000) can be fitted a few meters (feet) from the joint outlet point from the waterworks to obtain closed loop regulation. Danfoss MBS 33 and MBS 3000 is a two-wire transmitter (4-20 mA) that can be powered directly from a VLT 8000 AQUA. The required setpoint (e.g. 5 bar) can be set locally in parameter 418 *Setpoint 1*.

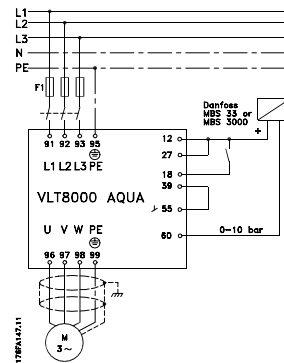
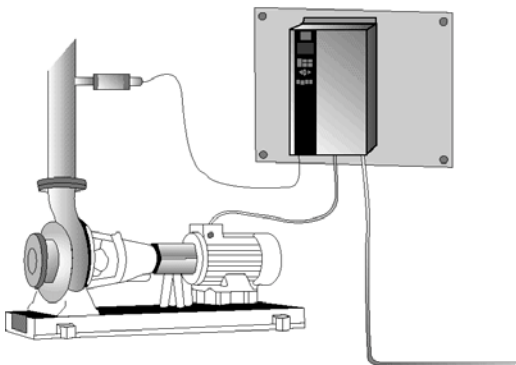

Assume:

Transmitter is scaled 0-10 Bar, minimum flow is achieved at 30 Hz. An increase in motor speed increases the pressure.

Set the following parameters:

Par. 100	Configuration	Closed loop [1]
Par. 201	Minimum Output Frequency	30 Hz
Par. 202	Maximum Output Frequency	50 Hz (or 60 Hz)
Par. 204	Minimum Reference	0 Bar
Par. 205	Maximum Reference	10 Bar
Par. 302	Terminal 18 Digital inputs	Start [1]
Par. 314	Terminal 60, analog input current	Feedback signal [2]
Par. 315	Terminal 60, min. scaling	4 mA
Par. 316	Terminal 60, max. scaling	20 mA
Par. 403	Sleep mode timer	10 sec.
Par. 404	Sleep frequency	35 Hz
Par. 405	Wake-up frequency	45 Hz
Par. 406	Boost setpoint	125%
Par. 413	Minimum Feedback	0 Bar
Par. 414	Maximum Feedback	10 Bar
Par. 415	Process units	Bar [16]
Par. 418	Setpoint 1	5 bar
Par. 420	PID control action	Normal
Par. 423	PID Proportional gain	0.3*
Par. 424	PID Integral time	30 sec.*

* The PID tuning parameters depend on the actual system dynamics.

■ PC software and serial communication

Danfoss offers various options for serial communication. Using serial communication, it is possible to monitor, program and control one or several frequency converters from a centrally located computer. All VLT 8000 AQUA units have an RS 485 port as standard with a choice of two protocols. The protocols selectable in parameter 500 protocols are:

- FC Protocol
- Modbus RTU

A bus option card allows higher transmission speed than RS 485. In addition, a higher number of units can be linked to the bus and alternative transmission media can be used. Danfoss offers the following option cards for communication:

- Profibus
- LonWorks
- DeviceNet

Information on the installation of various options is not included in these operating instructions.

Using the RS 485 port enables communication, e.g. with a PC. A Windows™ program, called *MCT 10*, is available for this purpose. It can be used to monitor, program and control one or several VLT 8000 AQUA units.

MCT 10 Set-up Software

MCT 10 has been designed as an easy to use interactive tool for setting parameters in our frequency converters.

The MCT 10 Set-up Software will be useful for:

- Planning a communication network off-line. MCT 10 contains a complete frequency converter database
- Commissioning frequency converters on line
- Saving settings for all frequency converters
- Replacing a drive in a network
- Expanding an existing network
- Future developed drives will be supported

MCT 10 Set-up Software support Profibus DP-V1 via a Master class 2 connection. It makes it possible to on line read/write parameters in a frequency converter via the Profibus network. This will eliminate the need for an extra communication network.

The MCT 10 Set-up Software Modules

The following modules are included in the software package:

MCT 10 Set-up Software

Setting parameters
Copy to and from frequency converters
Documentation and print out of parameter settings incl. diagrams

SyncPos

Creating SyncPos programme

Ordering number:

Please order your CD containing MCT 10 Set-up Software using code number 130B1000.

■ PC Software tools
PC Software - MCT 10

All drives are equipped with a serial communication port. We provide a PC tool for communication between PC and frequency converter, VLT Motion Control Tool MCT 10 Set-up Software.

■ Fieldbus options

The increasing need for information in building management systems makes it necessary to collect or visualise many different types of process data. Important process data can help the system technician in the day to day monitoring of the system, which means that a negative development, e. g. an increase in energy consumption, can be rectified in time.

The substantial amount of data in large buildings may generate a need for a higher transmission speed than 9600 baud.

■ Profibus

Profibus is a fieldbus system with FMS and DP, which can be used for linking automation units,

such as sensors and actuators, to the controls by means of a two-conductor cable.

Profibus **FMS** is used if major communication tasks are to be solved at cell and system level by means of large volumes of data.

Profibus **DP** is an extremely fast communication protocol, made specially for communication between the automation system and various units.

VLT 8000 AQUA only supports DP.

■ LON - Local Operating Network

LonWorks is an intelligent fieldbus system which improves the possibility of decentralising control,

as communication is enabled between individual units in the same system (Peer-to-Peer). This means that there is no need for a big main station for handling all the signals of the system (Master-Slave). Signals are sent direct to the unit that needs them via a common network medium. This makes communication much more flexible and the central building state control and monitoring system can be changed into a dedicated building state monitoring system whose task is to ensure that everything is running as planned. If the potential of LonWorks is fully utilised, sensors will also be connected to the bus, which means that a sensor signal can quickly be moved to another controller. If room dividers are mobile, this is a particularly useful feature.

■ DeviceNet

DeviceNet is a digital, multi-drop network, based on the CAN protocol, that connects and serves as a communication network between industrial controllers and I/O devices. Each device and/or controller is a node on the network. DeviceNet is a producer-consumer network that supports multiple communication hierarchies and message prioritization. DeviceNet systems can be configured to operate in a master-slave or a distributed control architecture using peer-to-peer communication. This system offers a single point of connection for configuration and control by supporting both I/O and explicit messaging. DeviceNet also has the feature of having power on the network. This allows devices with limited power requirements to be powered directly from the network via the 5-conductor cable.

■ Modbus RTU

MODBUS RTU (Remote Terminal Unit) Protocol is a messaging structure developed by Modicon in 1979, used to establish master-slave/client-server communication between intelligent devices. MODBUS is used to monitor and program devices; to communicate intelligent devices with sensors and instruments; to monitor field devices using PCs and HMIs. MODBUS is often applied in Gas and Oil applications, but also in building, infrastructure, transportation and energy, applications are making use of its benefits.

■ Accessories

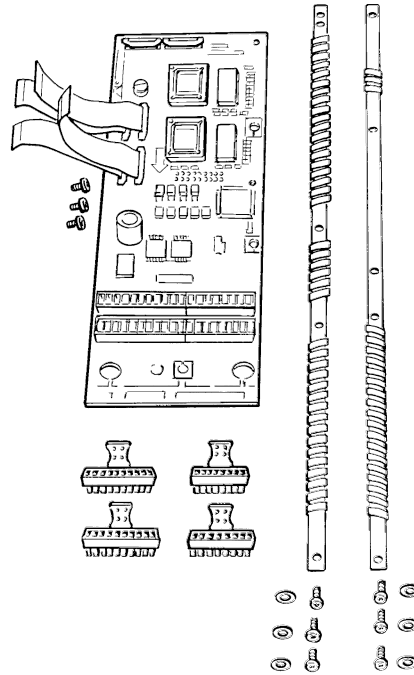
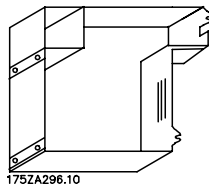
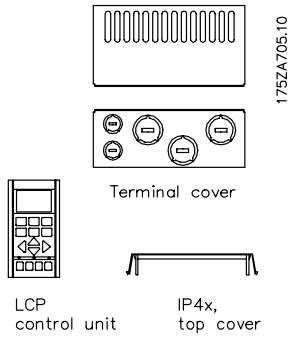

IP 20 bottom cover

Application option

Introduction

Type	Description	Order no.
IP 4x top cover IP ¹⁾	Option, VLT type 8006-8011 380-480 V compact	175Z0928
IP 4 x top cover ¹⁾	Option, VLT type 8002-8011 525-600 V compact	175Z0928
NEMA 12 bonding plate ²⁾	Option, VLT type 8006-8011 380-480 V	175H4195
IP 20 terminal cover	Option, VLT type 8006-8022 200-240 V	175Z4622
IP 20 terminal cover	Option, VLT type 8027-8032 200-240 V	175Z4623
IP 20 terminal cover	Option, VLT type 8016-8042 380-480 V	175Z4622
IP 20 terminal cover	Option, VLT type 8016-8042 525-600 V	175Z4622
IP 20 terminal cover	Option, VLT type 8052-8072 380-480 V	175Z4623
IP 20 terminal cover	Option, VLT type 8102-8122 380-480 V	175Z4280
IP 20 terminal cover	Option, VLT type 8052-8072 525-600 V	175Z4623
IP 20 bottom cover	Option, VLT type 8042-8062 200-240 V	176F1800
IP 20 bottom cover	Option, VLT type 8100-8150 525-600 V	176F1800
IP 20 bottom cover	Option, VLT type 8200-8300 525-600 V	176F1801
Terminal adaptor kit	VLT type 8042-8062 200-240 V, IP 54	176F1808
Terminal adaptor kit	VLT type 8042-8062 200-240 V, IP 00/NEMA 1	176F1805
Terminal adaptor kit	VLT type 8100-8150 525-600 V, IP 00/NEMA 1	176F1805
Terminal adaptor kit	VLT type 8200-8300 525-600 V, IP 00/NEMA 1	176F1811
Terminal adaptor kit	VLT type 8450-8600, 380-480 V, EX	176F1815
Control panel LCP	Separate LCP	175Z7804
LCP remote-mounting kit IP 00 & 20 ³⁾	Remote-mounting kit, incl. 3 m cable	175Z0850
LCP remote-mounting kit IP 54 ⁴⁾	Remote-mounting kit, incl. 3 m cable	175Z7802
LCP blind cover	for all IP00/IP20 drives	175Z7806
Cable for LCP	Separate cable (3 m)	175Z0929
Relay card	Application card with four relay outputs	175Z3691
Cascade controller card	With conformal coating	175Z3692
Profibus option	Without/with conformal coating	175Z3685/175Z3686
LonWorks option, Free topology	Without conformal coating	176F0225
Modbus RTU option	Without conformal coating	175Z3362
DeviceNet option	Without conformal coating	176F0224
MCT 10 Set-up software	CD-Rom	130B1000
MCT 31 Harmonic calculation	CD-Rom	130B1031

Rittal Installation Kit

Type	Description	Order No.
Rittal TS8 enclosure for IP00 ⁵⁾	Installation kit for 1800mm high enclosure, VLT8152-8202, 380-480V; VLT8052-8202, 525-690V	176F1824
Rittal TS8 enclosure for IP00 ⁵⁾	Installation kit for 2000mm high enclosure, VLT8152-8202, 380-480V; VLT8052-8202, 525-690V	176F1826
Rittal TS8 enclosure for IP00 ⁵⁾	Installation kit for 1800mm high enclosure, VLT8252-8352, 380-480V; VLT8252-8402, 525-690V	176F1823
Rittal TS8 enclosure for IP00 ⁵⁾	Installation kit for 2000mm high enclosure, VLT8252-8352, 380-480V; VLT8252-8402, 525-690V	176F1825
Floor stand for IP21 and IP54 enclosure ⁵⁾	Option, VLT8152-8352, 380-480V; VLT 8052-8402, 525-690V	176F1827

- 1) IP 4x/NEMA 1 top cover is for IP 20 units only and only horizontal surfaces comply with IP 4x. The kit also contains a bonding plate (UL).
- 2) NEMA 12 bonding plate (UL) is only for IP 54 units.
- 3) The remote-mounting kit is only for IP 00 and IP 20 units. Enclosure of the remote-mounting kit is IP 65.
- 4) The remote-mounting kit is only for IP 54 units. Enclosure of the remote-mounting kit is IP 65.
- 5) For details: See VLT 5000 / 6000 HVAC / 8000 AQUA Installation Instruction, MI.90.JX.YY.

VLT 8000 AQUA is available with an integral fieldbus option or application option. Ordering numbers for the individual VLT types with integrated options can be seen from the relevant manuals or instructions. In addition, the ordering number system can be used for ordering a frequency converter with an option.

■ Cascade Controller Option

In "Standard Mode", one motor is controlled by the drive that has the Cascade Controller Option card installed in it. Up to four additional fixed speed motors can be sequenced on & off, as required by the process, in lead-lag mode.

In "Master/Slave Mode", the drive that has the Cascade Controller option card installed in it, along with its associated motor, is designated as the master. Up to four additional motors, each with its own drive, can be operated in slave mode. The Cascade Controller functions to stage the slave drives/motors - on & off (as required), as a function of "best system operating efficiency".

In "Lead Pump Alternation Mode", it is possible to average out the usage of the pumps. This is done by making the frequency converter switch between the pumps (max. 4) by means of a timer. Please note that this mode requires an external relay setup.

Consult your Danfoss Sales Office for additional information.

This filter reduces the voltage rise time, the peak voltage U_{PEAK} and the ripple current ΔI to the motor, thereby making current and voltage almost sinusoidal. The acoustic motor noise is therefore reduced to a minimum.

Because of the ripple current in the coils, there will be some noise from the coils. This problem can be solved entirely by integrating the filter in a cabinet or similar.

■ LC filters for VLT 8000 AQUA

When a motor is controlled by a frequency converter, resonance noise will be heard from the motor. This noise, which is caused by the design of the motor, occurs each time one of the inverter switches in the frequency converter is activated. Consequently, the resonance noise frequency corresponds to the switching frequency of the frequency converter.

For the VLT 8000 AQUA, Danfoss offers a LC filter to dampen the acoustic motor noise.

■ Examples of the use of LC filtersSubmersible pumps

For small motors with up to and including 5.5 kW rated motor power, use an LC filter, unless the motor is equipped with phase separation paper. This applies e.g. to all wet running motors. If these motors are used without LC filter in connection with a frequency converter, the motor windings will short-circuit. If in doubt, ask the motor manufacturer whether the motor in question is equipped with phase separation paper.

Well pumps

If immersion pumps are used, e.g. submerged pumps or well pumps, the supplier should be contacted for clarification of requirements. It is recommended to use a LC filter if a frequency converter is used for well pump applications.

■ Ordering numbers, LC filter modules
Mains supply 3 x 200 - 240 V

LC filter for VLT type	LC filter enclosure	Rated current at 200 V	Max. output frequency	Power loss	Order no.
8006-8008	IP 00	25.0 A	60 Hz	85 W	175Z4600
8011	IP 00	32 A	60 Hz	90 W	175Z4601
8016	IP 00	46 A	60 Hz	110 W	175Z4602
8022	IP 00	61 A	60 Hz	170 W	175Z4603
8027	IP 00	73 A	60 Hz	250 W	175Z4604
8032	IP 00	88 A	60 Hz	320 W	175Z4605
8042	IP 00	115 A	60 Hz		175Z4702
8052	IP 00	143 A	60 Hz		175Z4702
8062	IP 00	170 A	60 Hz		175Z4703

Mains supply 3 x 380 - 480

LC filter for VLT type	LC filter enclosure	Rated current at 400/480 V	Max. output frequency	Power loss	Order no.
8006-8011	IP 20	16 A / 16 A	120 Hz		175Z0832
8016	IP 00	24 A / 21.7 A	60 Hz	125 W	175Z4606
8022	IP 00	32 A / 27.9 A	60 Hz	130 W	175Z4607
8027	IP 00	37.5 A / 32 A	60 Hz	140 W	175Z4608
8032	IP 00	44 A / 41.4 A	60 Hz	170 W	175Z4609
8042	IP 00	61 A / 54 A	60 Hz	250 W	175Z4610
8052	IP 00	73 A / 65 A	60 Hz	360 W	175Z4611
8062	IP 00	90 A / 78 A	60 Hz	450 W	175Z4612
8072	IP 20	106 A / 106 A	60 Hz		175Z4701
8102	IP 20	147 A / 130 A	60 Hz		175Z4702
8122	IP 20	177 A / 160 A	60 Hz		175Z4703
8152	IP 20	212 A / 190 A	60 Hz		175Z4704
8202	IP 20	260 A / 240 A	60 Hz		175Z4705
8252	IP 20	315 A / 302 A	60 Hz		175Z4706
8302	IP 20	395 A / 361 A	60 Hz		175Z4707
8352	IP 20	480 A / 443 A	60 Hz		175Z3139
8450	IP 20	600 A / 540 A	60 Hz		175Z3140
8500	IP 20	658 A / 590 A	60 Hz		175Z3141
8600	IP 20	745 A / 678 A	60 Hz		175Z3142

Regarding LC filters for 525 - 600 V, please contact Danfoss.

NB!:

When using LC filters, the switching frequency must be 4.5 kHz (see parameter 407).

Mains supply 3 x 690 V

VLT	Rated Current at 690 V	Max. output frequency (Hz)	Power dissipation (W)	Ordering no. IP00	Ordering no. IP20
8052	54	60	290	130B2223	130B2258
8062	73	60	390	130B2225	130B2260
8072	86	60	480	130B2225	130B2260
8102	108	60	600	130B2226	130B2261
8122	131	60	550	130B2228	130B2263
8152	155	60	680	130B2228	130B2263
8202	192	60	920	130B2229	130B2264
8252	242	60	750	130B2231	130B2266
8302	290	60	1000	130B2231	130B2266
8352	344	60	1050	130B2232	130B2267
8402	400	60	1150	130B2234	130B2269

dU/dt filters

The dU/dt filters reduce dU/dt to approx. 500 V / μ sec. These filters do not reduce noise or Upeak.



NB!:

When using dU/dt filters, the switching frequency must be 1.5 kHz (see parameter 411)

Mains supply 3 x 690 V

VLT	Rated Current at 690 V	Max. output frequency (Hz)	Power dissipation (W)	Ordering no. IP 00	Ordering no. IP20
8052	54	60	90	130B2154	130B2188
8062	73	60	100	130B2155	130B2189
8072	86	60	110	130B2156	130B2190
8102	108	60	120	130B2157	130B2191
8122	131	60	150	130B2158	130B2192
8152	155	60	180	130B2159	130B2193
8202	192	60	190	130B2160	130B2194
8252	242	60	210	130B2161	130B2195
8302	290	60	350	130B2162	130B2196
8352	344	60	480	130B2163	130B2197
8402	400	60	540	130B2165	130B2199

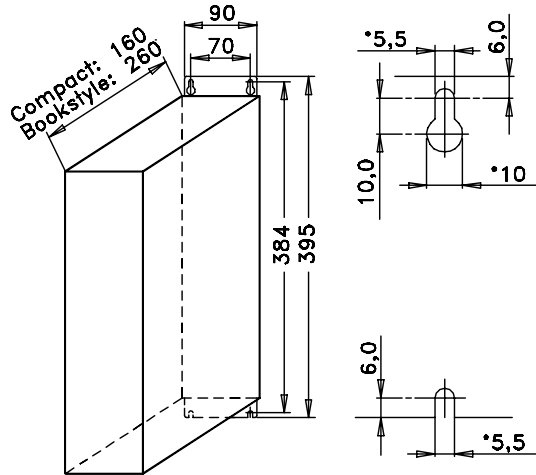
■ LC filters VLT 8006-8011 380 - 480 V



175ZA106.11

The drawing on the left gives the measurements of IP 20 LC filters for the above-mentioned power range. Min. space above and under enclosure: 100 mm.

IP 20 LC filters have been designed for side-by-side installation without any space between enclosures.

Max. motor cable length:

- 150 m screened/armoured cable
- 300 m unscreened/unarmoured cable

If EMC standards are to be complied with:

EN 55011-1B: Max. 50 screened/armoured cable

EN 55011-1A: Max. 150 m screened/armoured cable

Weight: 175Z0832

9.5 kg

■ Installation of LC filter IP 20

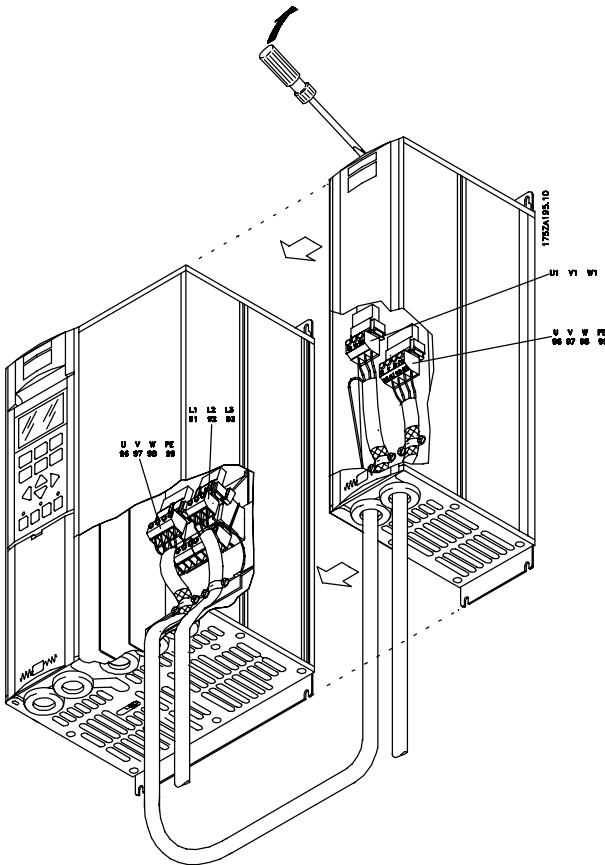

■ LC filters VLT 8006-8032, 200 - 240 V /
8016-8062 380 - 480 V

The table and the drawing give the measurements of IP 00 LC filters for Compact units.

IP 00 LC filters must be integrated and protected against dust, water and corrosive gases.

Max. motor cable length:

- 150 m screened/armoured cable
- 300 m unscreened/unarmoured cable

If EMC standards are to be complied with:

- EN 55011-1B: Max. 50 screened/armoured cable
- EN 55011-1A: Max. 150 m screened/armoured cable

LC filter IP 00

LC type	A [mm]	B [mm]	C [mm]	D [mm]	E [mm]	F [mm]	G [mm]	Weight [kg]
175Z4600	220	135	92	190	68	170	8	10
175Z4601	220	145	102	190	78	170	8	13
175Z4602	250	165	117	210	92	180	8	17
175Z4603	295	200	151	240	126	190	11	29
175Z4604	355	205	152	300	121	240	11	38
175Z4605	360	215	165	300	134	240	11	49
175Z4606	280	170	121	240	96	190	11	18
175Z4607	280	175	125	240	100	190	11	20
175Z4608	280	180	131	240	106	190	11	23
175Z4609	295	200	151	240	126	190	11	29
175Z4610	355	205	152	300	121	240	11	38
175Z4611	355	235	177	300	146	240	11	50
175Z4612	405	230	163	360	126	310	11	65

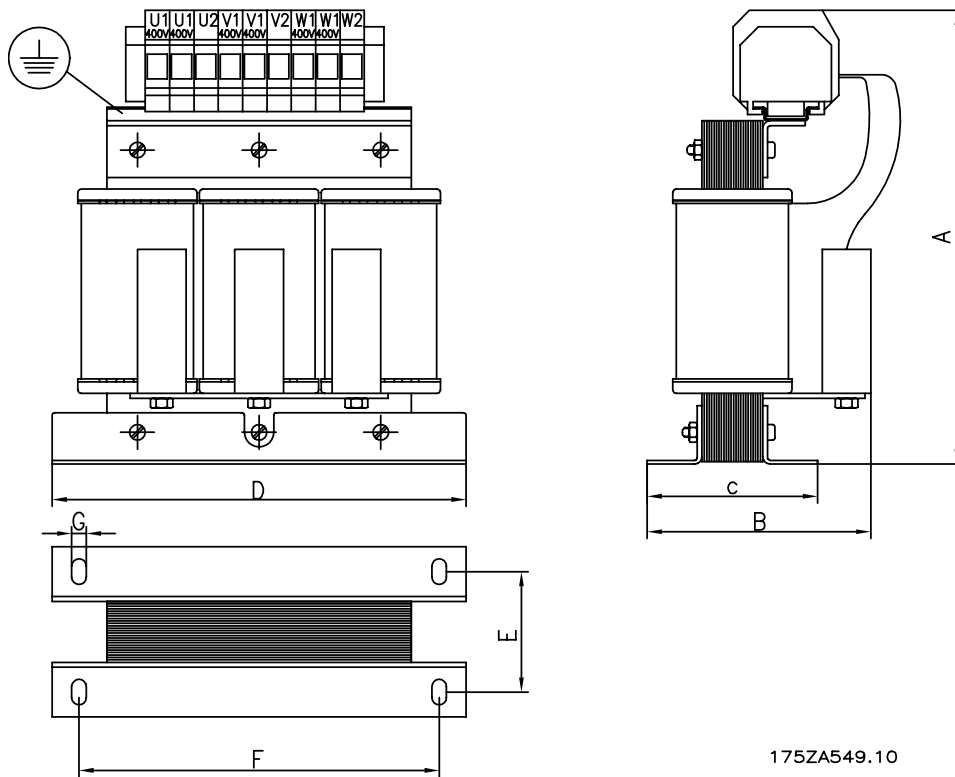

■ LC filter VLT 8042-8062 200-240 V /
8072-8600 380 - 480 V

The table and the drawing give the measurements of IP 20 LC filters. IP 20 LC filters must be integrated and protected against dust, water and aggressive gases.

Max. motor cable length:

- 150 m screened/armoured cable
- 300 m unscreened/unarmoured cable

If EMC standards are to be complied with:

- EN 55011-1B: Max. 50 m screened/armoured cable
- EN 55011-1A: Max. 150 m screened/armoured cable

LC-filter IP 20

LC type	A [mm]	B [mm]	C [mm]	D [mm]	E [mm]	F [mm]	G [mm]	Weight [kg]
175Z4701	740	550	600					70
175Z4702	740	550	600					70
175Z4703	740	550	600					110
175Z4704	740	550	600					120
175Z4705	830	630	650					220
175Z4706	830	630 </td <td>650</td> <td></td> <td></td> <td></td> <td></td> <td>250</td>	650					250
175Z4707	830	630	650					250
175Z3139	1350	800	1000					350
175Z3140	1350	800	1000					400
175Z3141	1350	800	1000					400
175Z3142	1350	800	1000					470

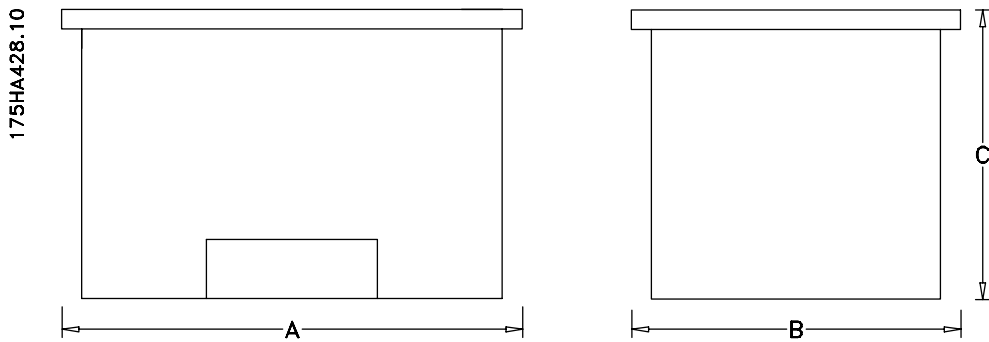

■ Harmonic filter

Harmonic currents do not directly affect the electricity consumption but has an impact on following conditions:

- Higher total current to be handled by the installations
- Increases load on transformer (sometimes it will require a larger transformer, particular at retrofit)
 - Increases heat losses in transformer and installation
 - In some cases demands larger cables, switches and fuses
- Higher voltage distortion due to higher current
- Increase risk for disturbing electronic equipment connected to same grid

A high percentage of rectifier load from eg frequency converters, will increase the harmonic current, which must be reduced to avoid the above consequences. Therefore the frequency converter has as standard, built in DC coils reducing the total current with about 40% (compared to devices without any arrangement for harmonic suppression), down to 40-45% ThiD.

In some cases there is a need for further suppression (eg retrofit with frequency converters). For this purpose Danfoss can offer two advanced harmonic filters AHF05 and AHF10, bringing the harmonic current down to around 5% and 10% respectively. For further details see instruction MG.80.BX.YY.

MCT 31

The MCT 31 harmonic calculation PC tool enables easy estimation of the harmonic distortion in a given application. Both the harmonic distortion of Danfoss frequency converters as well as non-Danfoss frequency converters with different additional harmonic reduction measurements, such as Danfoss AHF filters and 12-18-pulse rectifiers, can be calculated.

Ordering number:

Please order your CD containing the MCT 31 PC tool using code number 130B1031.

■ Ordering numbers, Harmonic filters

Harmonic filters are used to reduce mains harmonics

- AHF 010: 10% current distortion
- AHF 005: 5% current distortion

380-415 V, 50 Hz

I _{AHF,N}	Typical Motor Used [kW]	Danfoss ordering number		VLT 8000
		AHF 005	AHF 010	
10 A	4, 5.5	175G6600	175G6622	8006, 8008
19 A	7.5	175G6601	175G6623	8011, 8016
26 A	11	175G6602	175G6624	8022
35 A	15, 18.5	175G6603	175G6625	8027
43 A	22	175G6604	175G6626	8032
72 A	30, 37	175G6605	175G6627	8042, 8052
101 A	45, 55	175G6606	175G6628	8062, 8072
144 A	75	175G6607	175G6629	8102
180 A	90	175G6608	175G6630	8122
217 A	110	175G6609	175G6631	8152
289 A	132, 160	175G6610	175G6632	8202, 8252
324 A		175G6611	175G6633	
370 A	200	175G6688	175G6691	8302
Higher ratings can be achieved by paralleling the filter units				
434 A	250	Two 217 A units		8352
578 A	315	Two 289 A units		8450
613 A	355	289 A and 324 A units		8600

Please note that the matching of the typical Danfoss frequency converter and filter is pre-calculated based on 400 V and assuming typical motor load (4 or 2 pole motor). VLT 8000 is based on a max. 110% torque application.

The pre-calculated filter current may be different than the input current ratings of VLT 8000 as stated in the respective operating instructions, as these numbers are based on different operating conditions.

440-480 V, 60 Hz

I _{AHF,N}	Typical Motor Used [HP]	Danfoss ordering number		VLT 8000
		AHF 005	AHF 010	
19 A	10, 15	175G6612	175G6634	8011, 8016
26 A	20	175G6613	175G6635	8022
35 A	25, 30	175G6614	175G6636	8027, 8032
43 A	40	175G6615	175G6637	8042
72 A	50, 60	175G6616	175G6638	8052, 8062
101 A	75	175G6617	175G6639	8072
144 A	100, 125	175G6618	175G6640	8102, 8122
180 A	150	175G6619	175G6641	8152
217 A	200	175G6620	175G6642	8202
289 A	250	175G6621	175G6643	8252
324 A	300	175G6689	175G6692	8302
370 A	350	175G6690	175G6693	8352
Higher ratings can be achieved by paralleling the filter units				
506 A	450	217 A and 289 A units		8450
578 A	500	Two 289 A units		8500
648 A	600	Two 324 A units		8600

Please note that the matching of the Danfoss frequency converter and filter is pre-calculated based on 480 V and assuming typical motor load. VLT 8000 is based on 110 % torque application.

The pre-calculated filter current may be varying from the input current ratings of VLT 8000 as stated in the respective operating instructions, as these numbers are based on different operating conditions.

690 V, 50 Hz

I _{AHF,N}	Typical motor used	Ordering no. AHF 005	Ordering no. AHF 010	VLT 8000 110%
43	37, 45	130B2328	130B2293	8052
72	55, 75	130B2330	130B2295	8062, 8072
101	90	130B2331	130B2296	8102
144	110, 132	130B2333	130B2298	8122, 8152
180	160	130B2334	130B2299	8202
217	200	130B2335	130B2300	8252
289	250	130B2331 & 130B2333	130B2301	8302
324	315	130B2333 & 130B2334	130B2302	8352
370	400	130B2334 & 130B2335	130B2304	8402

■ Unpacking and ordering a VLT frequency converter

If you are in doubt as to which frequency converter you have received and which options it contains, use the following to find out.

■ Type code ordering number string

On the basis of your order, the frequency converter is given an ordering number that can be seen from the nameplate on the unit. The number may look as follows:

VLT-8008-A-T4-C20-R3-DL-F10-A00-C0

This means that the frequency converter ordered is a VLT 8008 for three-phase mains voltage of 380-480 V (**T4**) in Compact enclosure IP 20 (**C20**). The hardware variant is with integral RFI filter, classes A & B (**R3**). The frequency converter features a control unit (**DL**) with a PROFIBUS option card (**F10**). No option card (A00) and no conformal coating (C0) Character no. 8 (**A**) indicates the application range of the unit: **A** = AQUA.

IP 00: This enclosure is only available for the larger power sizes of the VLT 8000 AQUA series. It is recommended for installation in standard cabinets.

IP 20/NEMA 1: This enclosure is used as standard enclosure for VLT 8000 AQUA. It is ideal for cabinet installation in areas where a high degree of protection is required. This enclosure also permits side-by-side installation.

IP 54: This enclosure can be fitted direct to the wall. Cabinets are not required. IP 54 units can also be installed side-by-side.

Hardware variant

The units in the programme are available in the following hardware variants:

- ST: Standard unit with or without control unit. Without DC terminals, except for VLT 8042-8062, 200-240 V
VLT 8016-8300, 525-600 V
- SL: Standard unit with DC terminals.
- EX: Extended unit with control unit, DC terminals, connection of external 24 V DC supply for back-up of control PCB.
- DX: Extended unit with control unit, DC terminals, built-in mains fuses and disconnect, connection of external 24 V DC supply for back-up of control PCB.
- PF: Standard unit with 24 V DC supply for back-up of control PCB and built-in main fuses. No DC terminals.
- PS: Standard unit with 24 V DC supply for back-up of control PCB. No DC terminals.
- PD: Standard unit with 24 V DC supply for back-up of control PCB, built-in main fuses and disconnect. No DC terminals.

RFI filter

Units for a mains voltage of 380-480 V and a motor power of up to 7.5 kW (VLT 8011) are always supplied with an integral class A1 & B filter. Units for higher motor power than these can be ordered either with or without an RFI filter. RFI filters are not available for 525-600 V units.

Control unit (keypad and display)

All types of units in the programme, except for IP 54 units, can be ordered either with or without the control unit. IP 54 units always come *with* a control unit.

All types of units in the programme are available with built-in application options including a relay card with four relays or a cascade controller card.

Conformal Coating

All types of units in the programme are available with or without conformal coating of the PCB.

200-240 V

Typecode	T2	C00	C20	CN1	C54	ST	SL	R0	R1	R3
Position in string	9-10	11-13	11-13	11-13	11-13	14-15	14-15	16-17	16-17	16-17
4.0 kW/5.0 HP	8006		X		X	X	X	X		X
5.5 kW/7.5 HP	8008		X		X	X	X	X		X
7.5 kW/10 HP	8011		X		X	X	X	X		X
11 kW/15 HP	8016		X		X	X	X	X		X
15 kW/20 HP	8022		X		X	X	X	X		X
18.5 kW/25 HP	8027		X		X	X	X	X		X
22 kW/30 HP	8032		X		X	X	X	X		X
30 kW/40 HP	8042	X		X	X	X		X	X	
37 kW/50 HP	8052	X		X	X	X		X	X	
45 kW/60 HP	8062	X		X	X	X		X	X	

380-480 V

Typecode	T4	C00	C20	CN1	C54	ST	SL	EX	DX	PS	PD	PF	R0	R1	R3
Position in string	9-10	11-13	11-13	11-13	11-13	14-15	14-15	14-15	14-15	14-15	14-15	14-15	16-17	16-17	16-17
4.0 kW/5.0 HP	8006		X		X	X				X					X
5.5 kW/7.5 HP	8008		X		X	X				X					X
7.5 kW/10 HP	8011		X		X	X				X				X	
11 kW/15 HP	8016		X		X	X	X			X			X		X
15 kW/20 HP	8022		X		X	X	X			X			X		X
18.5 kW/25 HP	8027		X		X	X	X			X			X		X
22 kW/30 HP	8032		X		X	X	X			X			X		X
30 kW/40 HP	8042		X		X	X	X			X			X		X
37 kW/50 HP	8052		X		X	X	X			X			X		X
45 kW/60 HP	8062		X		X	X	X			X			X		X
55 kW/75 HP	8072		X		X	X	X			X			X		X
75 kW/100 HP	8102		X		X	X	X			X			X		X
90 kW/125 HP	8122		X		X	X	X			X			X		X
110 kW/150 HP	8152	X		X	X	X		X	X	X	X	X	X	X	
132 kW/200 HP	8202	X		X	X	X		X	X	X	X	X	X	X	
160 kW/250 HP	8252	X		X	X	X		X	X	X	X	X	X	X	
200 kW/300 HP	8302	X		X	X	X		X	X	X	X	X	X	X	
250 kW/350 HP	8352	X		X	X	X		X	X	X	X	X	X	X	
315 kW/450 HP	8450	(X)		X	X			X	(X)				X	X	
355 kW/500 HP	8500	(X)		X	X			X	(X)				X	X	
400 kW/600 HP	8550	(X)		X	X			X	(X)				X	X	

(X): Compact IP 00 enclosure not available with DX

Voltage

T2: 200-240 VAC

T4: 380-480 VAC

Enclosure

C00: Compact IP 00

C20: Compact IP 20

CN1: Compact NEMA 1

C54: Compact IP 54

Hardware variant

ST: Standard

SL: Standard with DC terminals

EX: Extended with 24 V supply and DC terminals

DX: Extended with 24 V supply, DC terminals, disconnect and fuse

PS: Standard with 24 V supply

PD: Standard with 24 V supply, fuse and disconnect

PF: Standard with 24 V supply and fuse

RFI filter

R0: Without filter

R1: Class A1 filter

R3: Class A1 and B filter

NB!:

NEMA 1 exceeds IP 20

525-600 V

Typecode	T6	C00	C20	CN1	ST	R0
Position in string	9-10	11-13	11-13	11-13	14-15	16-17
1.1 kW/1.5 HP	8002		X	X	X	X
1.5 kW/2.0 HP	8003		X	X	X	X
2.2 kW/3.0 HP	8004		X	X	X	X
3.0 kW/4.0 HP	8005		X	X	X	X
4.0 kW/5.0 HP	8006		X	X	X	X
5.5 kW/7.5 HP	8008		X	X	X	X
7.5 kW/10 HP	8011		X	X	X	X
11 kW/15 HP	8016			X	X	X
15 kW/20 HP	8022			X	X	X
18.5 kW/25 HP	8027			X	X	X
22 kW/30 HP	8032			X	X	X
30 kW/40 HP	8042			X	X	X
37 kW/50 HP	8052			X	X	X
45 kW/60 HP	8062			X	X	X
55 kW/75 HP	8072			X	X	X

525-690 V

Typecode	T6	C00	CN1	C54	ST	EX	DX	PS	PD	PF	R0
Position in string	9-10	11-13	11-13	11-13	11-13	11-13	14-15	14-15	14-15	14-15	16-17
45 kW/50 HP	8052	X	X	X	X	X	X	X	X	X	X
55 kW/60 HP	8062	X	X	X	X	X	X	X	X	X	X
75 kW/75 HP	8072	X	X	X	X	X	X	X	X	X	X
90 kW/100 HP	8102	X	X	X	X	X	X	X	X	X	X
110 kW/125 HP	8122	X	X	X	X	X	X	X	X	X	X
132 kW/150 HP	8152	X	X	X	X	X	X	X	X	X	X
160 kW/200 HP	8202	X	X	X	X	X	X	X	X	X	X
200 kW/250 HP	8252	X	X	X	X	X	X	X	X	X	X
250 kW/300 HP	8302	X	X	X	X	X	X	X	X	X	X
315 kW/350 HP	8352	X	X	X	X	X	X	X	X	X	X
400 kW/400 HP	8402	X	X	X	X	X	X	X	X	X	X

T6: 525-600 VAC
 C00: Compact IP 00
 C20: Compact IP 20
 CN1: Compact NEMA 1
 ST: Standard
 R0: Without filter

 **NB!:**
 NEMA 1 exceeds IP 20

Optional selections, 200-600 V

Display	Position: 18-19
D0 ¹⁾	Without LCP
DL	With LCP
Fieldbus option	Position: 20-22
F00	No options
F10	Profibus DP V1
F30	DeviceNet
F40	LonWorks free topology
Application option	Position: 23-25
A00	No options
A31 ²⁾	Relay card 4 relays
A32	Cascade Controller
Coating	Position: 26-27
C0 ³⁾	No coating
C1	With coating

1) Not available with enclosure compact IP 54

2) Not available with fieldbus options (Fxx)

3) Not available for power sizes from 8450 to 8600

■ General technical data

Mains supply (L1, L2, L3):

Supply voltage 200-240 V units	3 x 200/208/220/230/240 V ±10%
Supply voltage 380-480 V units	3 x 380/400/415/440/460/480 V ±10%
Supply voltage 525-600 V units	3 x 525/550/575/600 V ±10%
Supply voltage 525-690 V units	3 x 525/550/575/600/690 V ±10%
Supply frequency	50/60 Hz +/- 1%
Max. imbalance of supply voltage:	
VLT 8006-8011/380-480 V and VLT 8002-8011/525-600 V	±2.0% of rated supply voltage
VLT 8016-8072/525-600 V, 380-480 V and VLT 8006-8032/200-240 V	±1.5% of rated supply voltage
VLT 8102-8600/380-480 V and VLT 8042-8062/200-240 V	±3.0% of rated supply voltage
VLT 8052-8402/525-690 V	±3.0% of rated supply voltage
Displacement factor / cos. ϕ	near unity (> 0.98)
True Power Factor (λ)	nominal 0.90 at rated load
Input Mains (L1, L2, L3) Allowable On-OFF Switching Sequences	approx. 1 time/2 min.
Max. short-circuit current	100 kA

VLT output data (U, V, W):

Output voltage	0-100% of supply voltage
Output frequency 8006-8032, 200-240V	0 - 120 Hz, 0-1000 Hz
Output frequency 8042-8062, 200-240V	0 - 120 Hz, 0-450 Hz
Output frequency 8072-8600, 380-460V	0 - 120 Hz, 0-450 Hz
Output frequency 8002-8016, 525-600V	0 - 120 Hz, 0-1000 Hz
Output frequency 8022-8062, 525-600V	0 - 120 Hz, 0-450 Hz
Output frequency 8072, 525-600V	0 - 120 Hz, 0-450 Hz
Output frequency 8052-8352, 525-690V	0 - 132 Hz, 0-200 Hz
Output frequency 8402, 525-600V	0 - 132 Hz, 0-150 Hz
Rated motor voltage, 200-240 V units	200/208/220/230/240 V
Rated motor voltage, 380-480 V units	380/400/415/440/460/480 V
Rated motor voltage, 525-600 V units	525/550/575 V
Rated motor voltage, 525-690 V units	525/550/575/690 V
Rated motor frequency	50/60 Hz
Switching on output	Unlimited
Ramp times	1- 3600 sec.

Torque characteristics:

Starting torque	110% for 1 min.
Starting torque (parameter 110 <i>High break-away torque</i>)	Max. torque: 130% for 0.5 sec.
Acceleration torque	100%
Overload torque	110%

Control card, digital inputs:

Number of programmable digital inputs	8
Terminal nos.	16, 17, 18, 19, 27, 29, 32, 33
Voltage level	0-24 V DC (PNP positive logics)
Voltage level, logical "0"	< 5 V DC
Voltage level, logical "1"	> 10 V DC
Maximum voltage on input	28 V DC
Input resistance, R_i	approx. 2 k Ω
Scanning time per input	3 msec.

Reliable galvanic isolation: All digital inputs are galvanically isolated from the supply voltage (PELV). In addition, the digital inputs can be isolated from the other terminals on the control card by connecting an external 24 V DC supply and opening switch 4. See switches 1-4.

Control card, analogue inputs:

No. of programmable analogue voltage inputs/thermistor inputs	2
Terminal nos.	53, 54
Voltage level	0 - 10 V DC (scalable)
Input resistance, R_i	approx. 10 Ω
No. of programmable analogue current inputs	1
Terminal no. earth	55
Current range	0/4 - 20 mA (scalable)
Input resistance, R_i	approx. 200 Ω
Resolution	10 bit + sign
Accuracy on input	Max. error 1% of full scale
Scanning time per input	3 msec.

Reliable galvanic isolation: All analogue inputs are galvanically isolated from the supply voltage (PELV) and other high-voltage terminals.

Control card, pulse input:

No. of programmable pulse inputs	3
Terminal nos.	17, 29, 33
Max. frequency on terminal 17	5 kHz
Max. frequency on terminals 29, 33	20 kHz (PNP open collector)
Max. frequency on terminals 29, 33	65 kHz (Push-pull)
Voltage level	0-24 V DC (PNP positive logics)
Voltage level, logic "0"	< 5 V DC
Voltage level, logic "1"	> 10 V DC
Maximum voltage on input	28 V DC
Input resistance, R_i	approx. 2 k Ω
Scanning time per input	3 msec.
Resolution	10 bit + sign
Accuracy (100-1 kHz), terminals 17, 29, 33	Max. error: 0.5% of full scale
Accuracy (1-5 kHz), terminal 17	Max. error: 0.1% of full scale
Accuracy (1-65 kHz), terminals 29, 33	Max. error: 0.1% of full scale

Reliable galvanic isolation: All pulse inputs are galvanically isolated from the supply voltage (PELV).

In addition, pulse inputs can be isolated from the other terminals on the control card by connecting an external 24 V DC supply and opening switch 4. See switches 1-4.

Control card, digital/pulse and analogue outputs:

No. of programmable digital and analogue outputs	2
Terminal nos.	42, 45
Voltage level at digital/pulse output	0 - 24 V DC
Minimum load to frame (terminal 39) at digital/pulse output	600 Ω
Frequency ranges (digital output used as pulse output)	0-32 kHz
Current range at analogue output	0/4 - 20 mA
Maximum load to frame (terminal 39) at analog output	500 Ω
Accuracy of analogue output	Max. error: 1.5% of full scale
Resolution on analogue output.	8 bit

Reliable galvanic isolation: All digital and analog outputs are galvanically isolated from the supply voltage (PELV) and other high-voltage terminals.

Installation

Control card, 24 V DC supply:

Terminal nos.	12, 13
Max. load	200 mA
Terminal nos. earth	20, 39

Reliable galvanic isolation: The 24 V DC supply is galvanically isolated from the supply voltage (PELV), but has the same potential as the analogue outputs.

Control card, RS 485 serial communication :

Terminal nos.	68 (TX+, RX+), 69 (TX-, RX-)
--------------------	------------------------------

Reliable galvanic isolation: Full galvanic isolation (PELV).

Relay outputs:¹⁾

No. of programmable relay outputs	2
Terminal nos., control card (resistive load only)	4-5 (make)
Max. terminal load (AC1) on 4-5, control card	50 V AC, 1 A, 50 VA
Max. terminal load (DC1 (IEC 947)) on 4-5, control card	25 V DC, 2 A / 50 V DC, 1 A, 50 W
Max. terminal load (DC1) on 4-5, control card for UL/cUL applications	30 V AC, 1 A / 42.5 V DC, 1A
Terminal nos., power card (resistive and inductive load)	1-3 (break), 1-2 (make)
Max. terminal load (AC1) on 1-3, 1-2, power card	250 V AC, 2 A, 500 VA
Max. terminal load (DC1 (IEC 947)) on 1-3, 1-2, power card	25 V DC, 2 A / 50 V DC, 1A, 50 W
Min. terminal load (AC/DC) on 1-3, 1-2, power card	24 V DC, 10 mA / 24 V AC, 100 mA

1) Rated values for up to 300,000 operations.

At inductive loads the number of operations are reduced by 50%, alternatively the current can be reduced by 50%, thus the 300,000 operations are maintained.

External 24 Volt DC supply :

Terminal nos.	35, 36
Voltage range	24 V DC ±15% (max. 37 V DC for 10 sec.)
Max. voltage ripple	2 V DC
Power consumption	15 W - 50 W (50 W for start-up, 20 msec.)
Min. pre-fuse	6 Amp

Reliable galvanic isolation: Full galvanic isolation if the external 24 V DC supply is also of the PELV type.

Cable lengths and cross-sections:

Max. motor cable length, screened cable	150m/500 ft
Max. motor cable length, unscreened cable	300m/1000 ft
Max. motor cable length, screened cable VLT 8011 380-480 V	100m/330 ft
Max. motor cable length, screened cable VLT 8011 525-600 V	50m/164 ft
Max. DC-bus cable length, screened cable	25m/82 ft from frequency converter to DC bar.
<i>Max. cable cross-section to motor, see next section</i>	
Max. cross-section for 24 V external DC supply	2.5 mm ² /12 AWG
Max. cross-section for control cables	1.5 mm ² /16 AWG
Max. cross-section for serial communication	1.5 mm ² /16 AWG

If UL/cUL is to be complied with, copper cable with temperature class 60/75°C / 140/167°F must be used (VLT 8002 - 8072 (525 - 600 V), VLT 8006 - 8072 (380 - 480 V) and VLT 8002 - 8032 (200 - 240V). If UL/cUL is to be complied with, copper cable with temperature class 75°C/167°F must be used (VLT 8102 - 8600 (380 - 480 V), VLT 8042 - 8062 (200 - 240 V), VLT 8052 - 8402 (525-690 V)).

Connectors are for use of both copper and aluminium cables, unless other is specified.

Control characteristics:

Frequency range	0 - 120 Hz
Resolution on output frequency	±0.003 Hz

System response time 3 msec.
 Speed, control range (open loop) 1:100 of synchro. speed
 Speed, accuracy (open loop) < 1500 rpm: max. error \pm 7.5 rpm
 > 1500 rpm: max. error of 0.5% of actual speed
 Process, accuracy (closed loop) < 1500 rpm: max. error \pm 1.5 rpm
 > 1500 rpm: max. error of 0.1% of actual speed

All control characteristics are based on a 4-pole asynchronous motor

Accuracy of display readout (parameters 009-012 *Display readout*):

Motor current, 0 - 140% load Max. error: \pm 2.0% of rated output current
 Power kW, Power HP, 0 - 90% load Max. error: \pm 5.0% of rated output power

Externals:

Enclosure IP00/Chassis, IP20/IP21/NEMA 1, IP54/NEMA 12
 Vibration test 0.7 g RMS 18-1000 Hz random. 3 directions for 2 hours (IEC 68-2-34/35/36)
 Max. relative humidity 93 % +2 %, -3 % (IEC 68-2-3) for storage/transport
 Max. relative humidity 95% non condensing (IEC 721-3-3; class 3K3) for operation
 Aggressive environment (IEC 721-3-3) Uncoated class 3C2
 Aggressive environment (IEC 721-3-3) Coated class 3C3
 Ambient temperature, VLT 8006-8011 380-480 V, 8002-8011 525-600 V, IP 20//NEMA 1
 Max. 45°C (117°F) (24-hour average max. 40°C (104°F))
 Ambient temperature IP00/Chassis, IP20/NEMA 1, IP54/NEMA 12 Max.
 40°C/104°F (24-hour average max. 35°C/95°F)
see Derating for high ambient temperature
 Min. ambient temperature in full operation 0°C (32°F)
 Min. ambient temperature at reduced performance -10°C (14°F)
 Temperature during storage/transport -25° - +65°/70°C (-13° - +149°/158°F)
 Max. altitude above sea level 1000 m (3300 ft)
see Derating for high air pressure

Installation

NB!:



VLT 8002-8072, 525-600 V units do not comply with EMC, Low Voltage or PELV directives.

VLT 8000 AQUA protection:

- Electronic motor thermal protection against overload.
- Temperature monitoring of heat-sink ensures that the frequency converter cuts out if the temperature reaches 90°C (194 °F) for IP00, IP20 and NEMA 1. For IP54, the cut-out temperature is 80°C (176 °F). An overtemperature can only be reset when the temperature of the heat-sink has fallen below 60°C (140 °F).

For the units mentioned below, the limits are as follows:

- VLT 8152, 380-480 V, cuts out at 75 °C (167 °F) and can be reset if the temperature is below 60 °C (140 °F).
- VLT 8202, 380-480 V, cuts out at 80 °C (176 °F) and can be reset if the temperature has fallen below 60° C (140 °F).
- VLT 8252, 380-480 V, cuts out at 95 °C (203 °F) and can be reset if the temperature has fallen below 65° C (149 °F).
- VLT 8302, 380-480 V, cuts out at 95 °C (203 °F) and can be reset if the temperature has fallen below 65° C (149 °F).
- VLT 8352, 380-480 V, cuts out at 105 °C (221 °F) and can be reset if the temperature has fallen below 75° C (167 °F).
- VLT 8052-8152, 525-690 V, cuts out at 75 °C (167 °F) and can be reset if the temperature has fallen below 60° C (140 °F).
- VLT 8202-8402, 525-690 V, cuts out at 100°C (212 °F) and can be reset if the temperature has fallen below 70° C (158 °F).

- The frequency converter is protected against short-circuiting on motor terminals U, V, W.
- The frequency converter is protected against earth fault on motor terminals U, V, W.
- Monitoring of the intermediate circuit voltage ensures that the frequency converter cuts out if the intermediate circuit voltage gets too high or too low.
- If a motor phase is missing, the frequency converter cuts out.
- If there is a mains fault, the frequency converter is able to carry out a controlled deceleration.
- If a mains phase is missing, the frequency converter will cut out or autoderate when a load is placed on the motor.

■ Technical data, mains supply 3 x 200 - 240 V

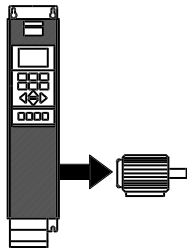
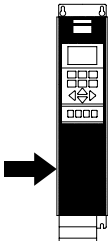
According to international requirements		VLT type	8006	8008	8011	
	Output current ⁴⁾	$I_{VLT,N}$ [A]	16.7	24.2	30.8	
		$I_{VLT,MAX}$ (60 s) [A]	18.4	26.6	33.9	
	Output power (240 V)	$S_{VLT,N}$ [kVA]	6.9	10.1	12.8	
	Typical shaft output	$P_{VLT,N}$ [kW]	4.0	5.5	7.5	
	Typical shaft output	$P_{VLT,N}$ [HP]	5	7.5	10	
	Max. cable cross-section to motor and DC-bus	[mm ²] / [AWG]		10/8	16/6	16/6
	Max. input current	(200 V) (RMS) $I_{L,N}$ [A]	16.0	23.0	30.0	
	Max. cable cross-section power	[mm ²] / [AWG] ²⁾	4/10	16/6	16/6	
	Max. pre-fuses	[-] / UL ¹⁾ [A]	35/30	50	60	
	Mains contactor	[Danfoss type]	CI 6	CI 9	CI 16	
	Efficiency ³⁾		0.95	0.95	0.95	
	Weight IP 20	[kg/lbs]	23/51	23/51	23/51	
	Weight IP 54	[kg/lbs]	35/77	35/77	38/84	
	Power loss at max. load. [W]	Total	194	426	545	
	Enclosure	VLT type	IP 20/ NEMA 1, IP 54/NEMA 12			

1. For type of fuse, see section *Fuses*.
2. American Wire Gauge.
3. Measured using 30 m/100 ft screened motor cables at rated load and rated frequency.
4. Current ratings fulfill UL requirements for 208-240 V.

■ Technical data, mains supply 3 x 200 - 240 V

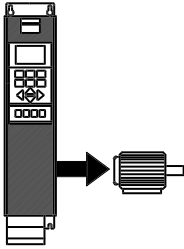
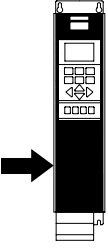
According to international requirements	VLT type	8016	8022	8027	8032	8042	8052	8062	
 Output current ⁴⁾	$I_{VLT,N}$ [A] (200-230 V)	46.2	59.4	74.8	88.0	115	143	170	
	$I_{VLT,MAX}$ (60 s) [A] (200-230 V)	50.6	65.3	82.3	96.8	127	158	187	
	$I_{VLT,N}$ [A] (240 V)	46.0	59.4	74.8	88.0	104	130	154	
	$I_{VLT,MAX}$ (60 s) [A] (240 V)	50.6	65.3	82.3	96.8	115	143	170	
 Output power	$S_{VLT,N}$ [kVA] (240 V)	19.1	24.7	31.1	36.6	41.0	52.0	61.0	
	Typical shaft output	$P_{VLT,N}$ [kW]	11	15	18.5	22	30	37	45
	Typical shaft output	$P_{VLT,N}$ [HP]	15	20	25	30	40	50	60
Max. cable cross-section to motor and DC-bus [mm ²]/[AWG] ^{2) 5)}	Copper	16/6	35/2	35/2	50/0	70/1/0	95/3/0	120/4/0	
	Aluminium ⁶⁾	16/6	35/2	35/2	50/0	95/3/0 ⁵⁾	90/250 mcm ⁵⁾	120/300 mcm ⁵⁾	
Min. cable cross-section to motor and DC-bus [mm ²]/[AWG] ²⁾		10/8	10/8	10/8	16/6	10/8	10/8	10/8	
Max. input current (200 V) (RMS) $I_{L,N}$ [A]		46.0	59.2	74.8	88.0	101.3	126.6	149.9	
Max. cable cross-section power [mm ²]/[AWG] ^{2) 5)}	Copper	16/6	35/2	35/2	50/0	70/1/0	95/3/0	120/4/0	
	Aluminium ⁶⁾	16/6	35/2	35/2	50/0	95/3/0 ⁵⁾	90/250 mcm ⁵⁾	120/300 mcm ⁵⁾	
Max. pre-fuses [-]/UL ¹⁾ [A]		60	80	125	125	150	200	250	
Mains contactor [Danfoss type] [AC value]	CI 32	CI 32	CI 32	CI 37	CI 61	CI 85	CI 85	CI 141	
	AC-1	AC-1	AC-1	AC-1	AC-1				
Efficiency ³⁾		0.95	0.95	0.95	0.95	0.95	0.95	0.95	
Weight IP 00/Chassis		[kg/lbs]	-	-	-	90/198	90/198	90/198	
Weight IP 20/NEMA 1		[kg/lbs]	23/51	30/66	30/66	48/106	101/223	101/223	
Weight IP 54		[kg/lbs]	38/84	49/108	50/110	55/121	104/229	104/229	
Power loss at max. load.		[W]	545	783	1042	1243	1089	1361	
Enclosure		IP 00/IP 20/NEMA 1/IP 54/NEMA 12							

1. For type of fuse, see section *Fuses*.

2. American Wire Gauge.

3. Measured using 30 m/100 ft screened motor cables at rated load and rated frequency.

4. Current ratings fulfill UL requirements for 208-240 V.

5. Connection stud 1 x M8 / 2 x M8.

6. Aluminium cables with cross section above 35 mm² must be connected by use of an Al-Cu connector.

■ Technical data, mains supply 3 x 380 - 480 V

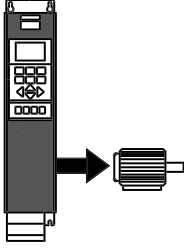
According to international requirements		VLT type	8006	8008	8011
	Output current	$I_{VLT,N}$ [A] (380-440 V)	10.0	13.0	16.0
		$I_{VLT, MAX}$ (60 s) [A] (380-440 V)	11.0	14.3	17.6
	Output power	$I_{VLT, N}$ [A] (441-480 V)	8.2	11.0	14.0
		$I_{VLT, MAX}$ (60 s) [A] (441-480 V)	9.0	12.1	15.4
Typical shaft output	$S_{VLT,N}$ [kVA] (400 V)	7.2	9.3	11.5	
	$S_{VLT,N}$ [kVA] (460 V)	6.5	8.8	11.2	
Typical shaft output	$P_{VLT,N}$ [kW]	4.0	5.5	7.5	
Typical shaft output	$P_{VLT,N}$ [HP]	5	7.5	10	
Max. cable cross-section to motor	$[mm^2] / [AWG]^{2) 4)}$	4/10	4/10	4/10	
Max. input current (RMS)	$I_{L,N}$ [A] (380 V)	9.1	12.2	15.0	
	$I_{L,N}$ [A] (480 V)	8.3	10.6	14.0	
Max. cable cross-section power	$[mm^2] / [AWG]^{2) 4)}$	4/10	4/10	4/10	
Max. pre-fuses	$[-] / [UL^1] [A]$	25/20	25/25	35/30	
Mains contactor	[Danfoss type]	CI 6	CI 6	CI 6	
Efficiency ³⁾		0.96	0.96	0.96	
Weight IP 20/NEMA 1	[kg/lbs]	10.5/23	10.5/23	10.5/23	
Weight IP 54/NEMA 12	[kg/lbs]	14/31	14/31	14/31	
Power loss at max. load. [W]	Total	198	250	295	
	Enclosure	VLT type	IP 20/NEMA 1/IP 54/NEMA 12		

Installation

1. For type of fuse, see section *Fuses*.
 2. American Wire Gauge.
 3. Measured using 30 m/100 ft screened motor cables at rated load and rated frequency.
 4. Max. cable cross section is the maximum possible cable cross section that can be fitted on the terminals.
 Always comply with national and local regulations on min. cable cross-section.

■ Technical data, mains supply 3 x 380 - 480 V

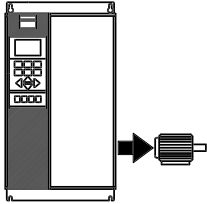
According to international requirements	VLT type	8016	8022	8027	8032	8042	
 Output current	$I_{VLT,N}$ [A] (380-440 V)	24.0	32.0	37.5	44.0	61.0	
	$I_{VLT,MAX}$ (60 s) [A] (380-440 V)	26.4	35.2	41.3	48.4	67.1	
	$I_{VLT,N}$ [A] (441-480 V)	21.0	27.0	34.0	40.0	52.0	
	$I_{VLT,MAX}$ (60 s) [A] (441-480 V)	23.1	29.7	37.4	44.0	57.2	
	Output power	$S_{VLT,N}$ [kVA] (400 V)	17.3	23.0	27.0	31.6	43.8
		$S_{VLT,N}$ [kVA] (460 V)	16.7	21.5	27.1	31.9	41.4
Typical shaft output	$P_{VLT,N}$ [kW]	11	15	18.5	22	30	
Typical shaft output	$P_{VLT,N}$ [HP]	15	20	25	30	40	
Max. cable cross-section to motor and DC-bus, IP 20	[mm ²]/[AWG] ^{2) 4)}	16/6	16/6	16/6	35/2	35/2	
Max. cable cross-section to motor and DC-bus, IP 54		16/6	16/6	16/6	16/6	35/2	
Min. cable cross-section to motor and DC-bus	[mm ²]/[AWG] ^{2) 4)}	10/8	10/8	10/8	10/8	10/8	
Max. input current (RMS)	$I_{L,N}$ [A] (380 V)	24.0	32.0	37.5	44.0	60.0	
	$I_{L,N}$ [A] (480 V)	21.0	27.6	34.0	41.0	53.0	
Max. cable cross-section power, IP 20	[mm ²]/[AWG] ^{2) 4)}	16/6	16/6	16/6	35/2	35/2	
		Max. cable cross-section power, IP 54	16/6	16/6	16/6	16/6	35/2
Max. pre-fuses	[-]/UL ¹⁾ [A]	63/40	63/40	63/50	63/60	80/80	
Mains contactor	[Danfoss type]	CI 9	CI 16	CI 16	CI 32	CI 32	
Efficiency at rated frequency		0.96	0.96	0.96	0.96	0.96	
Weight IP 20/NEMA 1	[kg/lbs]	21/46	21/46	22/49	27/60	28/62	
Weight IP 54/NEMA 12	[kg/lbs]	41/90	41/90	42/93	42/93	54/119	
Power loss at max. load.	[W]	419	559	655	768	1065	
Enclosure		IP 20/NEMA 1/ IP 54/NEMA 12					

1. For type of fuse, see section *Fuses*.

2. American Wire Gauge.

3. Measured using 30 m/100 ft screened motor cables at rated load and rated frequency.

4. Min. cable cross-section is the smallest cable cross-section allowed to be fitted on the terminals. Max. cable cross section is the maximum possible cable cross section that can be fitted on the terminals.

Always comply with national and local regulations on min. cable cross-section.

■ Technical data, mains supply 3 x 380 - 480 V

According to international requirements		VLT type	8052	8062	8072	8102	8122
Output current	$I_{VLT,N}$ [A] (380-440 V)		73.0	90.0	106	147	177
	$I_{VLT, MAX}$ (60 s) [A] (380-440 V)		80.3	99.0	117	162	195
	$I_{VLT,N}$ [A] (441-480 V)		65.0	77.0	106	130	160
	$I_{VLT, MAX}$ (60 s) [A] (441-480 V)		71.5	84.7	117	143	176
Output power	$S_{VLT,N}$ [kVA] (400 V)		52.5	64.7	73.4	102	123
	$S_{VLT,N}$ [kVA] (460 V)		51.8	61.3	84.5	104	127
Typical shaft output	$P_{VLT,N}$ [kW]		37	45	55	75	90
Typical shaft output	$P_{VLT,N}$ [HP]		50	60	75	100	125
Max. cable cross-section to motor and DC-bus, IP 20	$[mm^2]/[AWG]^{2) 4) 6)}$		35/2	50/0	50/0	/ 250	/ 250
						mcm ⁵⁾	mcm ⁵⁾
Max. cable cross-section to motor and DC-bus, IP 54	$[mm^2]/[AWG]^{2) 4) 6)}$		35/2	50/0	50/0	/ 300	/ 300
						mcm ⁵⁾	mcm ⁵⁾
Min. cable cross-section to motor and DC-bus	$[mm^2]/[AWG]^{2) 4)}$		10/8	16/6	16/6	25/4	25/4
Max. input current (RMS)	$I_{L,N}$ [A] (380 V)		72.0	89.0	104	145	174
	$I_{L,N}$ [A] (480 V)		64.0	77.0	104	128	158
Max. cable cross-section power, IP 20	$[mm^2]/[AWG]^{2) 4) 6)}$		35/2	50/0	50/0	/ 250	/ 250
						mcm	mcm
Max. cable cross-section power, IP 54	$[mm^2]/[AWG]^{2) 4) 6)}$		35/2	50/0	50/0	/ 300	/ 300
						mcm	mcm
Max. pre-fuses	$[-]/[UL^1)$ [A]		100/100	125/125	150/150	225/225	250/250
Mains contactor	[Danfoss type]		CI 37	CI 61	CI 85	CI 85	CI 141
Efficiency at rated frequency			0.96	0.96	0.96	0.98	0.98
Weight IP 20/NEMA 1	[kg/lbs]		41/90	42/93	43/96	54/119	54/119
Weight IP 54/NEMA 12	[kg/lbs]		56/123	56/123	60/132	77/170	77/170
Power loss at max. load.	[W]		1275	1571	1322	1467	1766
Enclosure			IP 20/NEMA 1/IP 54/NEMA 12				

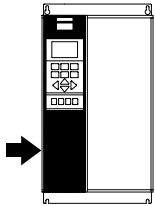
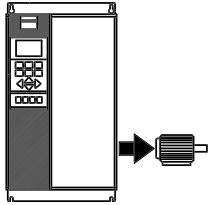

1. For type of fuse, see section *Fuses*.
2. American Wire Gauge.
3. Measured using 30 m/100 ft screened motor cables at rated load and rated frequency.
4. Min. cable cross-section is the smallest cable cross-section allowed to be fitted on the terminals.
Max. cable cross section is the maximum possible cable cross section that can be fitted on the terminals.
Always comply with national and local regulations on min. cable cross-section.
5. DC connection 95 mm²/AWG 3/0.
6. Aluminium cables with cross-section above 35 mm² must be connected by use of an Al-Cu connector.

■ Technical data, mains supply 3 x 380 - 480 V

According to international requirements		VLT type	8152	8202	8252	8302	8352
Output current	$I_{VLT,N}$ [A] (380-440 V)		212	260	315	395	480
	$I_{VLT,MAX}$ (60 s) [A] (380-440 V)		233	286	347	435	528
	$I_{VLT,N}$ [A] (441-480 V)		190	240	302	361	443
	$I_{VLT,MAX}$ (60 s) [A] (441-480 V)		209	264	332	397	487
Output power	$S_{VLT,N}$ [kVA] (400 V)		147	180	218	274	333
	$S_{VLT,N}$ [kVA] (460 V)		151	191	241	288	353
Typical shaft output (380-440 V) $P_{VLT,N}$ [kW]			110	132	160	200	250
Typical shaft output (441-480 V) $P_{VLT,N}$ [HP]			150	200	250	300	350
Max. cable cross-section to motor and DC-bus [mm ²] 2) 4) 5)			2x70	2x70	2x185	2x185	2x185
Max. cable cross-section to motor and DC-bus [AWG] 2) 4) 5)			2x2/0	2x2/0	2x350	2x350	2x350
Min. cable cross-section to motor and DC-bus [mm ² /AWG] 2) 4) 5)			35/2	35/2	35/2	35/2	35/2
Max. input current (RMS)	$I_{L,N}$ [A] (380 V)		208	256	317	385	467
	$I_{L,N}$ [A] (480 V)		185	236	304	356	431
Max. cable cross-section to power [mm ²] 4) 5)			2x70	2x70	2x185	2x185	2x185
Max. cable cross-section to power [AWG] 2) 4) 5)			2x2/0	2x2/0	2x350	2x350	2x350
Max. pre-fuses [-]/UL ¹⁾ [A]			300/300	350/350	450/400	500/500	630/600
Mains contactor [Danfoss type]			CI 141	CI 250EL	CI 250EL	CI 300EL	CI 300EL
Weight IP 00/ Chassis [kg/lbs]			82/181	91/201	112/247	123/271	138/304
Weight IP 20/ NEMA 1 [kg/lbs]			96/212	104/229	125/276	136/300	151/333
Weight IP 54/ NEMA 12 [kg/lbs]			96/212	104/229	125/276	136/300	151/333
Efficiency at rated frequency			0.98				
Power loss at max. load. [W]			2619	3309	4163	4977	6107
Enclosure			IP 00/Chassis/IP 21/NEMA 1/IP 54/NEMA 12				

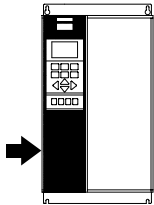
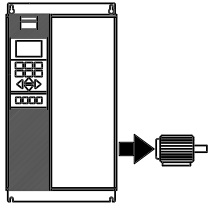

1. For type of fuse, see section *Fuses*.
2. American Wire Gauge.
3. Measured using 30 m/100 ft screened motor cables at rated load and rated frequency.
4. Min. cable cross-section is the smallest cable cross-section allowed to be fitted on the terminals. Max. cable cross section is the maximum possible cable cross section that can be fitted on the terminals.
Always comply with national and local regulations on min. cable cross-section.
5. Connection bolt 1 x M10 / 2 x M10 (mains and motor), connection bolt 1 x M8 / 2 x M8 (DC-bus).

■ Technical data, mains supply 3 x 380 - 480 V

According to international requirements	VLT type	8450	8500	8600
Output current	$I_{VLT,N}$ [A] (380-440 V)	600	658	745
	$I_{VLT,MAX}$ (60 s) [A] (380-440 V)	660	724	820
	$I_{VLT,N}$ [A] (441-480 V)	540	590	678
	$I_{VLT,MAX}$ (60 s) [A] (441-480 V)	594	649	746
Output power	$S_{VLT,N}$ [kVA] (400 V)	416	456	516
	$S_{VLT,N}$ [kVA] (480 V)	430	470	540
Typical shaft output (380-440 V)	$P_{VLT,N}$ [kW]	315	355	400
Typical shaft output (441-480 V)	$P_{VLT,N}$ [HP]	450	500	600
Max. cable cross-section to motor and DC-bus [mm ²] ^{4) 5)}		2 x 400	2 x 400	2 x 400
		3 x 150	3 x 150	3 x 150
Max. cable cross-section to motor and DC-bus [AWG] ^{2) 4) 5)}		2 x 750 mcm	2 x 750 mcm	2 x 750 mcm
		3 x 350 mcm	3 x 350 mcm	3 x 350 mcm
Min. cable cross-section to motor and DC-bus [mm ²] ^{4) 5)}		70	70	70
Min. cable cross-section to motor and DC-bus [AWG] ^{2) 4) 5)}		3/0	3/0	3/0
Max. input current (RMS)	$I_{L,MAX}$ [A] (380 V)	584	648	734
	$I_{L,MAX}$ [A] (480 V)	526	581	668
Max. cable cross-section to power [mm ²] ^{4) 5)}		2 x 400	2 x 400	2 x 400
		3 x 150	3 x 150	3 x 150
Max. cable cross-section to power [AWG] ^{2) 4) 5)}		2 x 750	2 x 750	2 x 750
		3 x 350	3 x 350	3 x 350
Min. cable cross-section to power [mm ²] ^{4) 5)}		70	70	70
Min. cable cross-section to power [AWG] ^{2) 4) 5)}		3/0	3/0	3/0
Max. pre-fuses (mains)	[]/UL [A] ¹⁾	700/700	800/800	800/800
Efficiency ³⁾		0.97	0.97	0.97
Mains contactor	[Danfoss type]	CI 300EL	-	-
Weight IP 00/ Chassis	[kg/lbs]	515/1136	560/1235	585/1290
Weight IP 20/ NEMA 1	[kg/lbs]	630/1389	675/1488	700/1544
Weight IP 54/ NEMA 12	[kg/lbs]	640/1411	685/1510	710/1566
Power loss at max. load	[W]	9450	10650	12000
Enclosure		IP 00/Chassis/IP 20/NEMA 1/IP 54/NEMA 12		

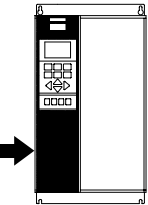
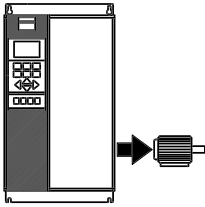

Installation

1. For type of fuse, see section *Fuses*.
2. American Wire Gauge.
3. Measured using 30 m/100 ft screened motor cables at rated load and rated frequency.
4. Min. cable cross-section is the smallest cable cross-section allowed to be fitted on the terminals. Always comply with national and local regulations on min. cable cross-section. Max. cable cross section is the maximum possible cable cross section that can be fitted on the terminals.
5. Connection stud 2 x M12/3 x M12.

■ Technical data, mains supply 3 x 525 - 600 V

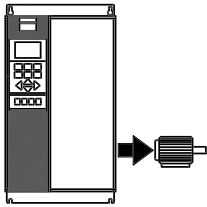
According to international requirements		VLT type	8002	8003	8004	8005	8006	8008	8011	
	Output current $I_{VLT,N}$ [A] (550 V)		2.6	2.9	4.1	5.2	6.4	9.5	11.5	
	$I_{VLT, MAX}$ (60 s) [A] (550 V)		2.9	3.2	4.5	5.7	7.0	10.5	12.7	
	$I_{VLT,N}$ [A] (575 V)		2.4	2.7	3.9	4.9	6.1	9.0	11.0	
	$I_{VLT, MAX}$ (60 s) [A] (575 V)		2.6	3.0	4.3	5.4	6.7	9.9	12.1	
	Output $S_{VLT,N}$ [kVA] (550 V)		2.5	2.8	3.9	5.0	6.1	9.0	11.0	
	$S_{VLT,N}$ [kVA] (575 V)		2.4	2.7	3.9	4.9	6.1	9.0	11.0	
	Typical shaft output $P_{VLT,N}$ [kW]		1.1	1.5	2.2	3	4	5.5	7.5	
	Typical shaft output $P_{VLT,N}$ [HP]		1.5	2	3	4	5	7.5	10	
	Max. copper cable cross-section to motor and loadsharing									
		[mm ²]	4	4	4	4	4	4	4	4
	[AWG] ²⁾	10	10	10	10	10	10	10	10	
Rated Input	$I_{VLT,N}$ [A] (550 V)	2.5	2.8	4.0	5.1	6.2	9.2	11.2		
Current	$I_{VLT,N}$ [A] (600 V)	2.2	2.5	3.6	4.6	5.7	8.4	10.3		
Max.copper cable cross-section, power										
	[mm ²]	4	4	4	4	4	4	4	4	
	[AWG] ²⁾	10	10	10	10	10	10	10	10	
Max. prefuses (mains) ¹⁾ [-]/UL [A]		3	4	5	6	8	10	15		
Efficiency		0.96								
Weight IP 20 / NEMA 1	[kg/lbs]	10.5/ 23	10.5/ 23	10.5/ 23	10.5/ 23	10.5/ 23	10.5/ 23	10.5/ 23	10.5/ 23	
Estimated power loss at max. load (550 V) [W]		65	73	103	131	161	238	288		
Estimated power loss at max. load (600V) [W]		63	71	102	129	160	236	288		
Enclosure		IP 20/NEMA 1								

1. For type of fuse, see section *Fuses*.

2. American Wire Gauge (AWG).

3. Min. cable cross-section is the smallest cable cross-section allowed to be fitted into the terminals to comply with IP20. Always comply with national and local regulations on min. cable cross-section.

■ Technical data, mains supply 3 x 525 - 600 V

According to international requirements		8016	8022	8027	8032	8042	8052	8062	8072
Output current $I_{VLT,N}$ [A] (550 V)		18	23	28	34	43	54	65	81
$I_{VLT,MAX}$ (60 s) [A] (550V)		20	25	31	37	47	59	72	89
$I_{VLT,N}$ [A] (575 V)		17	22	27	32	41	52	62	77
$I_{VLT,MAX}$ (60 s) [A] (575 V)		19	24	30	35	45	57	68	85
Output	$S_{VLT,N}$ [kVA] (550 V)	17	22	27	32	41	51	62	77
	$S_{VLT,N}$ [kVA] (575 V)	17	22	27	32	41	52	62	77
Typical shaft output $P_{VLT,N}$ [kW]		11	15	18.5	22	30	37	45	55
Typical shaft output $P_{VLT,N}$ [HP]		15	20	25	30	40	50	60	75
Max. copper cable									
cross-section to motor	[mm ²]	16	16	16	35	35	50	50	50
and loadsharing ⁴⁾	[AWG] ²⁾	6	6	6	2	2	1/0	1/0	1/0
Min. cable									
cross-section to motor	[mm ²]	0.5	0.5	0.5	10	10	16	16	16
and loadsharing ³⁾	[AWG] ²⁾	20	20	20	8	8	6	6	6
Rated Input Current									
$I_{VLT,N}$ [A] (550 V)		18	22	27	33	42	53	63	79
$I_{VLT,N}$ [A] (600 V)		16	21	25	30	38	49	58	72
Max copper cable	[mm ²]	16	16	16	35	35	50	50	50
cross section, power ⁴⁾	[AWG] ²⁾	6	6	6	2	2	1/0	1/0	1/0
Max. prefuses (mains) ¹⁾ [-]/UL [A]		20	30	35	45	60	75	90	100
Efficiency		0.96							
Weight IP 20/NEMA 1	[kg/lbs]	23/	23/	23/	30/	30/	48/	48/	48/
		51	51	51	66	66	106	106	106
Estimated power loss at max. load (550 V) [W]		451	576	702	852	1077	1353	1628	2029
Estimated power loss at max. load (600 V) [W]		446	576	707	838	1074	1362	1624	2016
Enclosure		IP 20/NEMA 1							

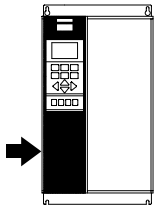
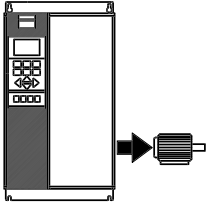

Installation

1. For type of fuse, see section *Fuses*.
2. American Wire Gauge (AWG).
3. Min. cable cross-section is the smallest cable cross-section allowed to be fitted into the terminals to comply with IP 20. Always comply with national and local regulations on min. cable cross-section.
4. Aluminium cables with cross-section above 35 mm² must be connected by use of an Al-Cu connector.

■ Technical data, mains supply 3 x 525-690 V

According to international requirements		VLT type	8052	8062	8072	8102	8122
Output current	$I_{M.T.N.}$ [A] (525-550 V)		56	76	90	113	137
	$I_{VLT,MAX}$ (60 s) [A] (525-550 V)		62	84	99	124	151
	$I_{M.T.N.}$ [A] (551-690 V)		54	73	86	108	131
	$I_{VLT,MAX}$ (60 s) [A] (551-690 V)		59	80	95	119	144
Output	$S_{M.T.N.}$ [kVA] (550 V)		53	72	86	108	131
	$S_{M.T.N.}$ [kVA] (575 V)		54	73	86	108	130
	$S_{M.T.N.}$ [kVA] (690 V)		65	87	103	129	157
Typical shaft output	[kW] (550 V)		37	45	55	75	90
	[HP] (575 V)		50	60	75	100	125
	[kW] (690 V)		45	55	75	90	110
Max. cable cross-section to motor	[mm ²] ^{4,5}		2 x 70				
	[AWG] ^{2,4,5}		2 x 2/0				
Max. cable cross-section to loadsharing and brake	[mm ²] ^{4,5}		2 x 70				
	[AWG] ^{2,4,5}		2 x 2/0				
Rated input current	$I_{L,N}$ [A] (550 V)	60	77	89	110	130	
	$I_{L,N}$ [A] (575 V)	58	74	85	106	124	
	$I_{L,N}$ [A] (690 V)	58	77	87	109	128	
Max. cable cross-section power supply	[mm ²] ^{4,5}		2 x 70				
	[AWG] ^{2,4,5}		2 x 2/0				
Min. cable cross-section to motor and power supply	[mm ²] ^{4,5}		35				
	[AWG] ^{2,4,5}		2				
Min. cable cross-section to brake and loadsharing	[mm ²] ^{4,5}		10				
	[AWG] ^{2,4,5}		8				
Max. pre-fuses (mains) [-]/UL	[A] ¹	125	160	200	200	250	
Efficiency ³		0.97	0.97	0.98	0.98	0.98	
Power loss	[W]	1458	1717	1913	2262	2662	
Weight	IP 00 [kg]			82			
Weight	IP 21/Nema1 [kg]			96			
Weight	IP 54/Nema12 [kg]			96			
Enclosure		IP 00, IP 21/Nema 1 and IP 54/Nema12					

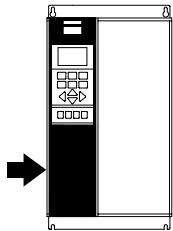
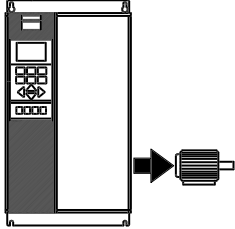

1. For type of fuse see section *Fuses*
2. American Wire Gauge.
3. Measured using 30 m screened motor cables at rated load and rated frequency.
4. Max. cable cross-section is the maximum possible cable cross-section allowed to be fitted on the terminals. Min. cable cross-section is the minimum allowed cross-section. Always comply with national and local regulations on min. cable cross-section.
5. Connection bolt 1 x M10 / 2 x M10 (mains and motor), connection bolt 1 x M8 / 2 x M8 (DC-bus).

■ Technical data, mains supply 3 x 525-690 V

According to international requirements		VLT type	8152	8202	8252	8302	8352	8402
Output current	$I_{M,T,N}$ [A] (525-550 V)		162	201	253	303	360	418
	$I_{VLT, MAX}$ (60 s) [A] (525-550 V)		178	221	278	333	396	460
	$I_{M,T,N}$ [A] (551-690 V)		155	192	242	290	344	400
	$I_{VLT, MAX}$ (60 s) [A] (551-690 V)		171	211	266	319	378	440
Output	$S_{VLT,N}$ [kVA] (550 V)		154	191	241	289	343	398
	$S_{VLT,N}$ [kVA] (575 V)		154	191	241	289	343	398
	$S_{VLT,N}$ [kVA] (690 V)		185	229	289	347	411	478
Typical shaft output	[kW] (550 V)		110	132	160	200	250	315
	[HP] (575 V)		150	200	250	300	350	400
	[kW] (690 V)		132	160	200	250	315	400
Max. cable cross-section to motor	[mm ²] ^{4,6}		2 x 70		2 x 185			
	[AWG] ^{2,4,5}		2 x 2/0		2 x 350 mcm			
Max. cable cross-section to loadsharing and brake	[mm ²] ^{4,6}		2 x 70		2 x 185			
	[AWG] ^{2,4,5}		2 x 2/0		2 x 350 mcm			
Rated input current	$I_{L,N}$ [A] (550 V)		158	198	245	299	355	408
	$I_{L,N}$ [A] (575 V)		151	189	234	286	339	390
	$I_{L,N}$ [A] (690 V)		155	197	240	296	352	400
Max. cable cross-section power supply	[mm ²] ^{4,6}		2 x 70		2 x 185			
	[AWG] ^{2,4,5}		2 x 2/0		2 x 350 mcm			
Min. cable cross-section to motor and power supply	[mm ²] ^{4,6}				35			
	[AWG] ^{2,4,5}				2			
Min. cable cross-section to brake and loadsharing	[mm ²] ^{4,6}				10			
	[AWG] ^{2,4,5}				8			
Max. pre-fuses (mains)	[A] ¹	315	350	350	400	500	550	
[-]/UL								
Efficiency ³					0,98			
Power loss	[W]	3114	3612	4293	5156	5821	6149	
Weight	IP 00 [kg]	82	91	112	123	138	151	
Weight	IP 21/Nema1 [kg]	96	104	125	136	151	165	
Weight	IP 54/Nema12 [kg]	96	104	125	136	151	165	
Enclosure		IP 00, IP 21/Nema 1 and IP 54/Nema12						

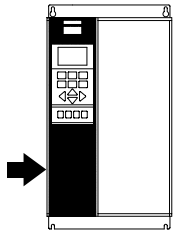
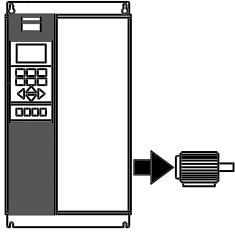

Installation

1. For type of fuse see section *Fuses*
2. American Wire Gauge.
3. Measured using 30 m screened motor cables at rated load and rated frequency.
4. Max. cable cross-section is the maximum possible cable cross-section allowed to be fitted on the terminals. Min. cable cross-section is the minimum allowed cross-section. Always comply with national and local regulations on min. cable cross-section.
5. Connection bolt 1 x M10 / 2 x M10 (mains and motor), connection bolt 1 x M8 / 2 x M8 (DC-bus).

■ Fuses
UL compliance

To comply with UL/cUL approvals, pre-fuses according to the table below must be used.

200-240 V

VLT	Bussmann	SIBA	Littel fuse	Ferraz-Shawmut
8006	KTN-R30	5017906-032	KLN-R30	ATM-R30 or A2K-30R
8008	KTN-R50	5012406-050	KLN-R50	A2K-50R
8011, 8016	KTN-R60	5014006-063	KLN-R60	A2K-60R
8022	KTN-R80	5014006-080	KLN-R80	A2K-80R
8027, 8032	KTN-R125	2028220-125	KLN-R125	A2K-125R
8042	FWX-150	2028220-150	L25S-150	A25X-150
8052	FWX-200	2028220-200	L25S-200	A25X-200
8062	FWX-250	2028220-250	L25S-250	A25X-250

380-480 V

	Bussmann	SIBA	Littel fuse	Ferraz-Shawmut
8006	KTS-R20	5017906-020	KLS-R20	ATM-R20 or A6K-20R
8008	KTS-R25	5017906-025	KLS-R25	ATM-R25 or A6K-25R
8011	KTS-R30	5012406-032	KLS-R30	ATM-R30 or A6K-30R
8016, 8022	KTS-R40	5014006-040	KLS-R40	A6K-40R
8027	KTS-R50	5014006-050	KLS-R50	A6K-50R
8032	KTS-R60	5014006-063	KLS-R60	A6K-60R
8042	KTS-R80	2028220-100	KLS-R80	A6K-80R
8052	KTS-R100	2028220-125	KLS-R100	A6K-100R
8062	KTS-R125	2028220-125	KLS-R125	A6K-125R
8072	KTS-R150	2028220-160	KLS-R150	A6K-150R
8102	FWH-220	2028220-200	L50S-225	A50-P225
8122	FWH-250	2028220-250	L50S-250	A50-P250
8152*	FWH-300	2028220-315	L50S-300	A50-P300
8202*	FWH-350	2028220-315	L50S-350	A50-P350
8252*	FWH-400	206xx32-400	L50S-400	A50-P400
8302*	FWH-500	206xx32-500	L50S-500	A50-P500
8352*	FWH-600	206xx32-600	L50S-600	A50-P600
8450	FWH-700	206xx32-700	L50S-700	A50-P700
8500	FWH-800	206xx32-800	L50S-800	A50-P800
8600	FWH-800	206xx32-800	L50S-800	A50-P800

* Circuit Breakers manufactured by General Electric, Cat. No. SKHA36AT0800 with the rating plug listed below can be used to meet UL requirement.

8152	rating plug No.	SRPK800 A 300
8202	rating plug No.	SRPK800 A 400
8252	rating plug No.	SRPK800 A 400
8302	rating plug No.	SRPK800 A 500
8352	rating plug No.	SRPK800 A 600

525-600 V

	Bussmann	SIBA	Littel fuse	Ferraz-Shawmut
8002	KTS-R3	5017906-004	KLS-R003	A6K-3R
8003	KTS-R4	5017906-004	KLS-R004	A6K-4R
8004	KTS-R5	5017906-005	KLS-R005	A6K-5R
8005	KTS-R6	5017906-006	KLS-R006	A6K-6R
8006	KTS-R8	5017906-008	KLS-R008	A6K-8R
8008	KTS-R10	5017906-010	KLS-R010	A6K-10R
8011	KTS-R15	5017906-016	KLS-R015	A6K-15R
8016	KTS-R20	5017906-020	KLS-R020	A6K-20R
8022	KTS-R30	5017906-030	KLS-R030	A6K-30R
8027	KTS-R35	5014006-040	KLS-R035	A6K-35R
8032	KTS-R45	5014006-050	KLS-R045	A6K-45R
8042	KTS-R60	5014006-063	KLS-R060	A6K-60R
8052	KTS-R75	5014006-080	KLS-R075	A6K-80R
8062	KTS-R90	5014006-100	KLS-R090	A6K-90R
8072	KTS-R100	5014006-100	KLS-R100	A6K-100R

525-600 V (UL) and 525-690 V (CE) drives

	Bussmann	SIBA	FERRAZ-SHAWMUT
8052	170M3013	2061032,125	6.6URD30D08A0125
8062	170M3014	2061032,16	6.6URD30D08A0160
8072	170M3015	2061032,2	6.6URD30D08A0200
8102	170M3015	2061032,2	6.6URD30D08A0200
8122	170M3016	2061032,25	6.6URD30D08A0250
8152	170M3017	2061032,315	6.6URD30D08A0315
8202	170M3018	2061032,35	6.6URD30D08A0350
8252	170M4011	2061032,35	6.6URD30D08A0350
8302	170M4012	2061032,4	6.6URD30D08A0400
8352	170M4014	2061032,5	6.6URD30D08A0500
8402	170M5011	2062032,55	6.6URD32D08A550

KTS-fuses from Bussmann may substitute KTN for 240 V drives.

FWH-fuses from Bussmann may substitute FWX for 240 V drives.

KLSR fuses from LITTEL FUSE may substitute KLNR fuses for 240 V drives.

L50S fuses from LITTEL FUSE may substitute L25S fuses for 240 V drives.

A6KR fuses from FERRAZ SHAWMUT may substitute A2KR for 240 V drives.

A50X fuses from FERRAZ SHAWMUT may substitute A25X for 240 V drives.

Non UL compliance

If UL/cUL is not to be complied with, we recommend the above mentioned fuses or:

VLT 8006-8032	200-240 V	type gG
VLT 8042-8062	200-240 V	type gR
VLT 8006-8072	380-480 V	type gG
VLT 8102-8122	380-480 V	type gR
VLT 8152-8352	380-480 V	type gG
VLT 8450-8600	380-480 V	type gR
VLT 8002-8072	525-600 V	type gG

Not following the recommendation may result in damage of the drive in case of malfunction. Fuses must be designed for protection in a circuit capable of supplying a maximum of 100000 A_{rms} (symmetrical), 500 V /600 V maximum.

■ Mechanical dimensions

All the below listed measurements are in mm./in

VLT type	A	B	C	a	b	aa/bb	Type	
IP 00/Chassis 200 - 240 V								
8042 - 8062	800/31.5	370/14.6	335/13.2	780/30.7	270/10.6	225/8.9	B	
IP 00 380 - 480 V								
8152 - 8202	1046/41.2	408/16.1	373/14.7 ¹⁾	1001/39.4	304/12.0	225/8.9	J	
8252 - 8352	1327/52.2	408/16.1	373/14.7 ¹⁾	1282/50.5	304/12.0	225/8.9	J	
8450 - 8600	1896/74.6	1099/43.3	490/19.3	1847/72.7	1065/41.9	400/15.7 (aa)	I	
IP 00 525 - 690 V								
8052 - 8202	1046/41.1	408/16	373 ¹⁾ /14.7	1001/39.4	304/12	225/8.7	J	
8252 - 8402	1327/52.2	408/16	373 ¹⁾ /14.7	1282/50.4	304/12	225/8.7	J	
IP 20/NEMA 1 200 - 240 V								
8006 - 8011	560/22.0	242/9.5	260/10.2	540/21.3	200/7.9	200/7.9	D	
8016 - 8022	700/27.6	242/9.5	260/10.2	680/26.8	200/7.9	200/7.9	D	
8027 - 8032	800/31.5	308/12.1	296/11.7	780/30.7	270/10.6	200/7.9	D	
8042 - 8062	954/37.6	370/14.6	335/13.2	780/30.7	270/10.6	225/8.9	E	
IP 20/NEMA 1 380 - 480 V								
8006 - 8011	395/15.6	220/8.7	200/7.9	384/15.1	200/7.9	100/3.9	C	
8016 - 8027	560/22.0	242/9.5	260/10.2	540/21.3	200/7.9	200/7.9	D	
8032 - 8042	700/27.6	242/9.5	260/10.2	680/26.8	200/7.9	200/7.9	D	
8052 - 8072	800/31.5	308/12.1	296/11.7	780/30.7	270/10.6	200/7.9	D	
8102 - 8122	800/31.5	370/14.6	335/13.2	780/30.7	330/13.0	225/8.9	D	
8450 - 8600	2010/79.1	1200/47.2	600/23.6	-	-	400/15.7 (aa)	H	
IP 21/NEMA 1 380-480 V								
8152 - 8202	1208/47.5	420/16.5	373/14.7 ¹⁾	1154/45.4	304/12.0	225/8.9	J	
8252 - 8352	1588/62.5	420/16.5	373/14.7 ¹⁾	1535/60.4	304/12.0	225/8.9	J	
IP 20/NEMA 1 525 - 600 V								
8002 - 8011	395/15.55	220/8.66	200/7.87	384/15.12	200/7.87	100/3.94	C	
8016 - 8027	560/22.05	242/9.53	260/10.23	540/21.26	200/7.87	200/7.87	D	
8032 - 8042	700/27.56	242/9.53	260/10.23	680/26.77	200/7.87	200/7.87	D	
8052 - 8072	800/31.50	308/12.13	296/11.65	780/30.71	270/10.63	200/7.87	D	
IP 21/NEMA 1 525- 690 V								
8052 - 8202	1208/47.5	420/16.5	373 ¹⁾ /14.7	1154/45.4	304/12	225/8.7	J	
8252 - 8402	1588/62.5	420/16.5	373 ¹⁾ /14.7	1535/60.4	304/12	225/8.7	J	
IP 54/NEMA 12 200 - 240 V								
8006 - 8011	810/31.9	350/13.8	280/11.0	70/2.8	560/22.0	326/12.8	200/7.9	F
8016 - 8032	940/37.0	400/15.7	280/11.0	70/2.8	690/27.2	375/14.8	200/7.9	F
8042 - 8062	937/36.9	495/9.5	421/16.6	-	830/32.7	374/14.8	225/8.9	G
IP 54/NEMA 12 380 - 480 V								
8006 - 8011	530/20.9	282/11.1	195/7.7	85/3.3	330/13.0	258/10.2	100/3.9	F
8016 - 8032	810/31.9	350/13.8	280/11.0	70/2.8	560/22.0	326/12.8	200/7.9	F
8042 - 8072	940/37.0	400/15.7	280/11.0	70/2.8	690/27.2	375/14.8	200/7.9	F
8102 - 8122	940/37.0	400/15.7	360/14.2	70/2.8	690/27.2	375/14.8	225/8.9	F
8152 - 8202	1208/47.5	420/16.3	373/14.7 ¹⁾	-	1154/45.4	304/12.0	225/8.9	J
8252 - 8352	1588/62.5	420/16.3	373/14.7 ¹⁾	-	1535/60.4	304/12.0	225/8.9	J
8450 - 8600	2010/79.1	1200/47.2	600/23.6	-	-	-	400/15.7 (aa)	H
IP 54/NEMA 12 525 - 690 V								
8052 - 8202	1208/47.5	420/16.5	373 ¹⁾ /14.7	1154/45.4	304/12	225/8.7	J	
8252 - 8402	1588/62.5	420/16.5	373 ¹⁾ /14.7	1535/60.4	304/12	225/8.7	J	

Installation

1. With disconnect add 44 mm/1.7 in

 aa: Minimum space above enclosure
 bb: Minimum space below enclosure

■ Mechanical dimensions

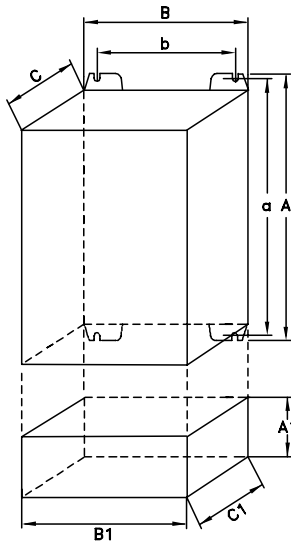

Type B, IP00
With option and enclosure IP20

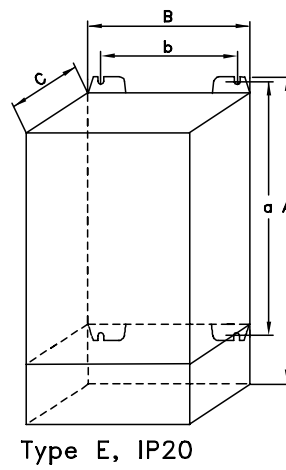
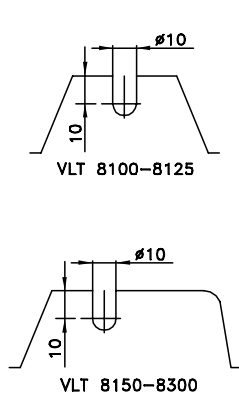

Type E, IP20

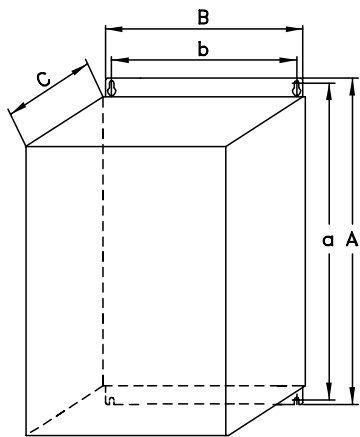
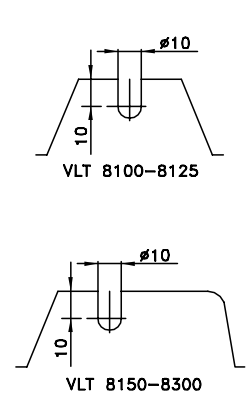

Type C, IP20

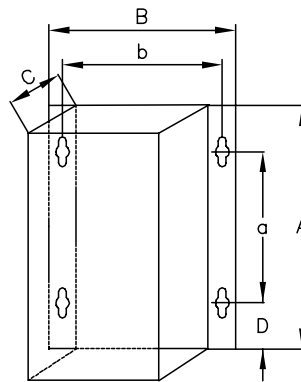
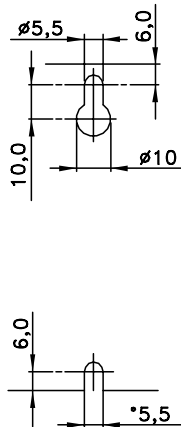

Type F, IP54

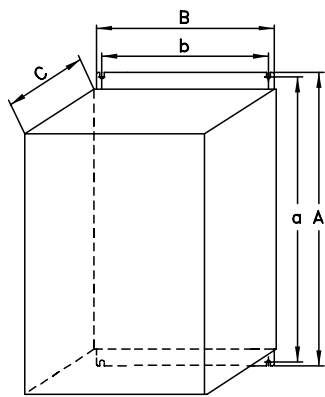
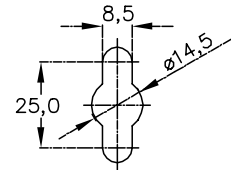

Type D, IP20

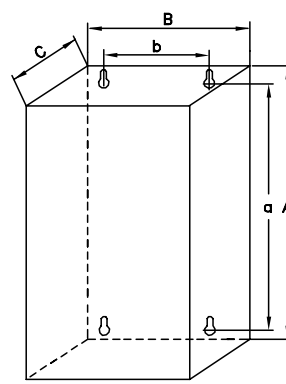
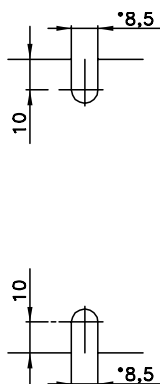

Type G, IP54

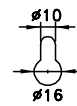

176FA224.10

■ Mechanical dimensions (cont.)

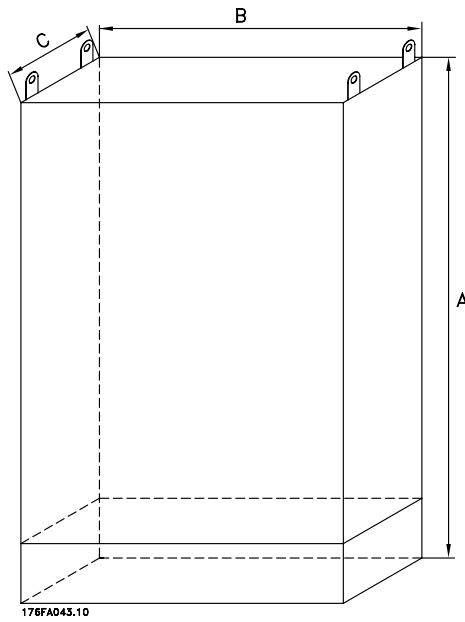

Type H, IP 20, IP 54

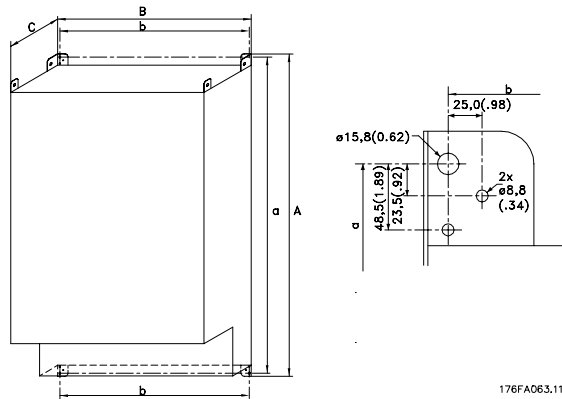

Type I, IP 00

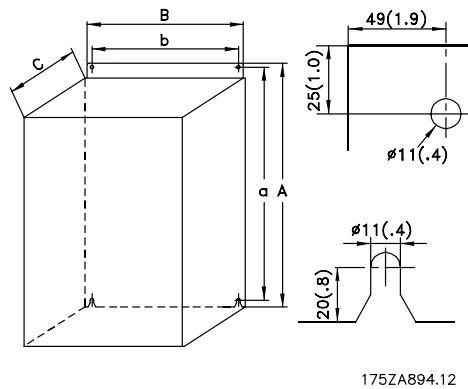

Type J, IP 00, IP 21, IP 54

Installation

■ Mechanical installation



Please pay attention to the requirements that apply to integration and field mounting kit, see the below list. The information given in the list must be observed to avoid serious damage or injury, especially when installing large units.

The frequency converter *must* be installed vertically.

The frequency converter is cooled by means of air circulation. For the unit to be able to release its cooling air, the *minimum* distance over and below the unit must be as shown in the illustration below.

To protect the unit from overheating, it must be ensured that the ambient temperature *does not rise above the max. temperature stated for the frequency converter* and that the 24-hour average temperature *is not exceeded*. The max. temperature and 24-hour average can be seen from the *General Technical Data*. If the ambient temperature is in the range of 45°C -55° C, derating of the frequency converter will become relevant, see *Derating for ambient temperature*. The service life of the frequency converter will be reduced if derating for ambient temperature is not taken into account.

■ Installation of VLT 8006-8352

All frequency converters must be installed in a way that ensures proper cooling.

Cooling

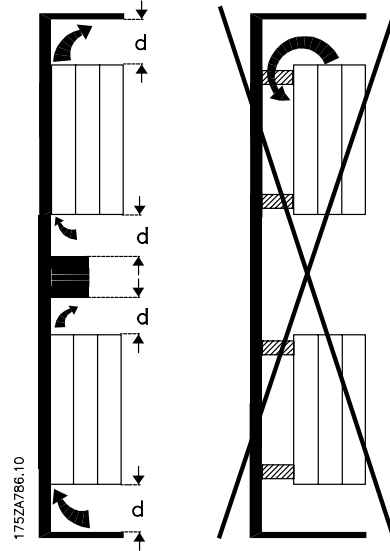

All units require a minimum space above and below the enclosure.

Side by side/flange by flange

All frequency converters can be mounted side by side/flange by flange.

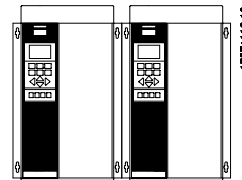
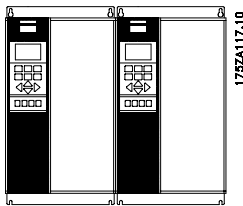

	d [mm/in]	Comments
Compact (all enclosure types)		
VLT 8006-8011, 380-480 V	100/3.9	Installation on a plane, vertical surface (no spacers)
VLT 8002-8011, 525-600 V	100/3.9	
VLT 8006-8032, 200-240 V	200/7.9	Installation on a plane, vertical surface (no spacers)
VLT 8016-8072 380-480 V	200/7.9	
VLT 8102-8122 380-480 V	225/8.9	
VLT 8016-8072 525-600 V	200/7.9	
VLT 8042-8062, 200-240 V	225/8.9	Installation on a plane, vertical surface (no spacers) IP 54 filter mats must be changed when they are dirty.
VLT 8152-8352, 380-480 V	225/8.9	
VLT 8052-8402, 525-690 V	225/8.9	

■ Installation of VLT 8450-8600 380-480 V Compact IP 00/Chassis, IP 20/NEMA 1 and IP 54/NEMA 12

Cooling

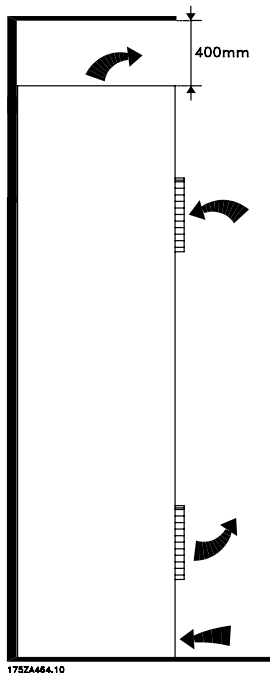

All units in the above-mentioned series require a minimum space of 400 mm (15.8 in) above the enclosure and must be installed on a plane floor. This applies to both IP 00/Chassis, IP 20/NEMA 1 and IP 54/NEMA 12 units. Gaining access to VLT 84500-8600 requires a minimum space of 605 mm (23.8 in) in front of the frequency converter.

Side-by-side

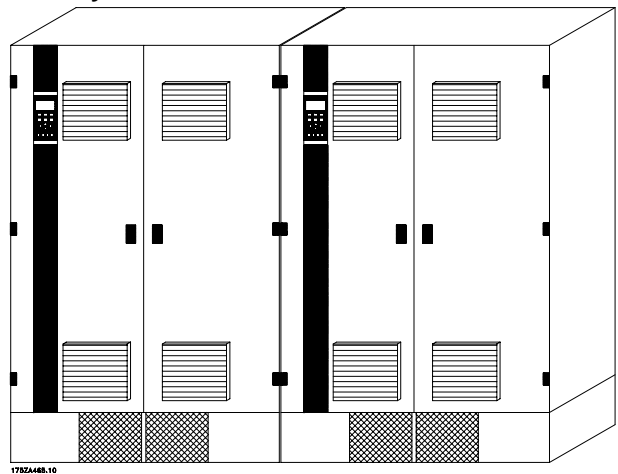

All IP 00/Chassis, IP 20/NEMA 1 and IP 54/NEMA 12 units in the above-mentioned series can be installed side by side without any space between them, since these units do not require cooling on the sides.

Installation

■ IP 00 VLT 8450-8600 380-480 V

The IP 00/Chassis unit is designed for installation in a cabinet when installed according to the instructions

in the Installation Guide MG.56.AX.YY. Please note, that the same conditions as for NEMA 1/ IP20 and IP54/NEMA 12 must be fulfilled.

■ General information about electrical installation

■ High voltage warning



The voltage of the frequency converter is dangerous whenever the equipment is connected to mains. Incorrect installation of the motor or the frequency converter may cause damage to the equipment, serious personal injury or death. Consequently, the instructions in these Operating Instructions, as well as national and local safety regulations, must be complied with. Touching the electrical parts may be fatal - even after disconnection from mains:

Using VLT 8006-8062, 200-240 V wait at least 15 minutes

Using VLT 8006-8072, 380-480 V wait at least 15 minutes

Using VLT 8102-8352, 380-480 V wait at least 20 minutes

Using VLT 8450-8600, 380-480 V wait at least 15 minutes

Using VLT 8002-8006, 525-600 V wait at least 4 minutes

Using VLT 8008-8027, 525-600 V wait at least 15 minutes

Using VLT 8032-8300, 525-600 V wait at least 30 minutes

Using VLT 8052-8402, 525-690 V wait at least 20 minutes



NB!:

It is the user's or certified electrician's responsibility to ensure correct earthing and protection in accordance with applicable national and local norms and standards.

■ Earthing

The following basic issues need to be considered when installing a frequency converter, so as to obtain electromagnetic compatibility (EMC).

- Safety earthing: Please note that the frequency converter has a high leakage current and must be earthed appropriately for safety reasons. Apply local safety regulations.
- High-frequency earthing: Keep the earth wire connections as short as possible.

Connect the different earth systems at the lowest possible conductor impedance. The lowest possible conductor impedance is obtained by keeping the conductor as short as possible and by using the greatest possible surface area. A flat conductor, for example, has a lower HF impedance than a round

conductor for the same conductor cross-section C_{VESS} . If more than one device is installed in cabinets, the cabinet rear plate, which must be made of metal, should be used as a common earth reference plate. The metal cabinets of the different devices are mounted on the cabinet rear plate using the lowest possible HF impedance. This avoids having different HF voltages for the individual devices and avoids the risk of radio interference currents running in connection cables that may be used between the devices. The radio interference will have been reduced. In order to obtain a low HF impedance, use the fastening bolts of the devices as HF connection to the rear plate. It is necessary to remove insulating paint or similar from the fastening points.

■ Cables

Control cables and the filtered mains cable should be installed separate from the motor cables so as to avoid interference overcoupling. Normally, a distance of 204mm (8 in) will be sufficient, but it is recommended to keep the greatest possible distance wherever possible, especially where cables are installed in parallel over a substantial distance.

With respect to sensitive signal cables, such as telephone cables and data cables, the greatest possible distance is recommended with a minimum of 1m (3 ft) per 5m (15 ft) of power cable (mains and motor cable). It must be pointed out that the necessary distance depends on the sensitivity of the installation and the signal cables, and that therefore no precise values can be stated.

If cable jaws are used, sensitive signal cables are not to be placed in the same cable jaws as the motor cable or brake cable.

If signal cables are to cross power cables, this should be done at an angle of 90 degrees.

Remember that all interference-filled in- or outgoing cables to/from a cabinet should be screened/armoured or filtered.

■ Screened/armoured cables

The screen must be a low HF-impedance screen. This is ensured by using a braided screen of copper, aluminium or iron. Screen armour intended for mechanical protection, for example, is not suitable for an EMC-correct installation. See also *Use of EMC-correct cables*.

■ Extra protection with regard to indirect contact

ELCB relays, multiple protective earthing or earthing can be used as extra protection, provided that local safety regulations are complied with. In the case of an earth fault, a DC content may develop in the faulty current.

Never use ELCB relays, type A, since such relays are not suitable for DC fault currents.

If ELCB relays are used, this must be:

- Suitable for protecting equipment with a direct current content (DC) in the faulty current (3-phase bridge rectifier)
- Suitable for power-up with short charging current to earth
- Suitable for a high leakage current

■ RFI switch

Mains supply isolated from earth:

If the frequency converter is supplied from an isolated mains source (IT mains) or TT/TN-S mains with grounded leg, the RFI switch is recommended to be turned off (OFF)¹⁾. For further reference, see IEC 364-3. In case optimum EMC performance is needed, parallel motors are connected or the motor cable length is above 25 m, it is recommended to set the switch in ON position.

In OFF position, the internal RFI capacities (filter capacitors) between the chassis and the intermediate circuit are cut off to avoid damage to the intermediate circuit and to reduce the earth capacity currents (according to IEC 61800-3).

Please also refer to the application note *VLT on IT mains*, MN.90.CX.02. It is important to use isolation monitors that are capable for use together with power electronics (IEC 61557-8).



NB!:

The RFI switch is not to be operated with mains connected to the unit. Check that the mains supply has been disconnected before operating the RFI switch.



NB!:

Open RFI switch is only allowed at factory set switching frequencies.



NB!:

The RFI switch connects the capacitors galvanically to earth.

The red switches are operated by means of e.g. a screwdriver. They are set in the OFF position when they are pulled out and in ON position when they are pushed in. Factory setting is ON.

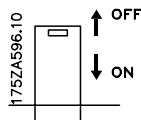

Mains supply connected to earth:

The RFI switch must be in ON position in order for the frequency converter to comply with the EMC standard.

1) Not possible with VLT 8052-8402, 525-690 V.

Position of RFI switches



Compact IP 20/NEMA 1

VLT 8006 - 8011 380 - 480 V

VLT 8002 - 8011 525 - 600 V



Compact IP 20/NEMA 1

VLT 8016 - 8027 380 - 480 V

VLT 8006 - 8011 200 - 240 V

VLT 8016 - 8027 525 - 600 V



Compact IP 20/NEMA 1

VLT 8032 - 8042 380 - 480 V

VLT 8016 - 8022 200 - 240 V

VLT 8032 - 8042 525 - 600 V



Compact IP 20/NEMA 1
VLT 8052 - 8122 380 - 480 V
VLT 8027 - 8032 200 - 240 V
VLT 8052 - 8072 525 - 600 V

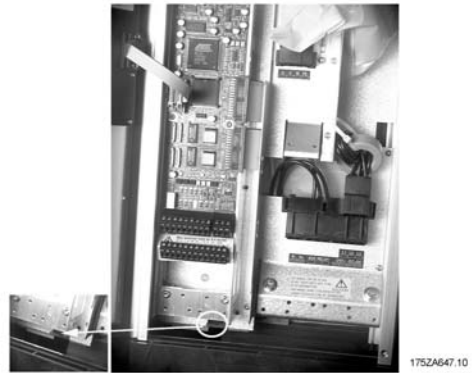

Compact IP 54/NEMA 12
VLT 8006 - 8011 380 - 480 V

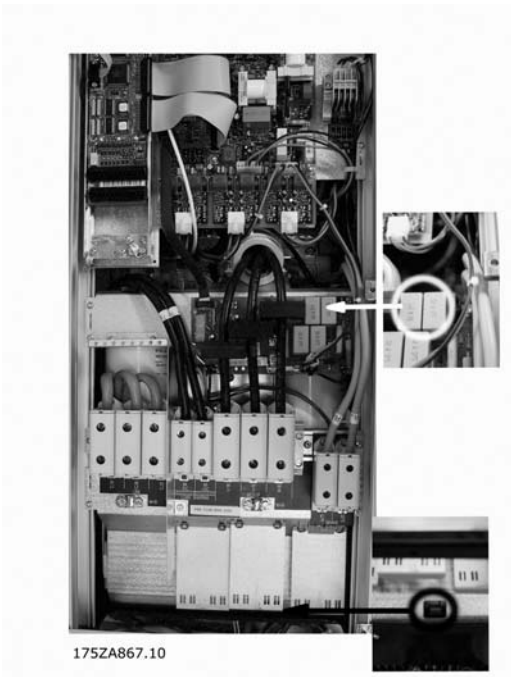

Compact IP 54/NEMA 12
VLT 8102 - 8122 380 - 480 V



Compact IP 54/NEMA 12
VLT 8016 - 8032 380 - 480 V
VLT 8006 - 8011 200 - 240 V



Compact IP 54/NEMA 12
VLT 8042 - 8072 380 - 480 V
VLT 8016 - 8032 200 - 240 V

Installation

■ **High voltage test**

A high voltage test can be carried out by short-circuiting terminals U, V, W, L₁, L₂ and L₃ and energizing by max. 2.5 kV DC for one second between this short-circuit and the chassis.



NB!:

The RFI switch must be closed (position ON) when high voltage tests are carried out .

The mains and motor connection must be interrupted in the case of high voltage tests of the total installation if the leakage currents are too high.

■ **Heat emission from VLT 8000 AQUA**

The tables in *General technical data* show the power loss P_φ (W) from VLT 8000 AQUA. The maximum cooling air temperature t_{IN, MAX} is 40° C (104° F) at 100% load (of rated value).

■ **Ventilation of integrated VLT 8000 AQUA**

The quantity of air required for cooling frequency converter can be calculated as follows:

1. Add up the values of P for all the frequency converters to be integrated in the same panel.
The highest cooling air temperature (t_{IN}) present must be lower than t_{IN, MAX} 40° C (104° F).
The day/night average must be 5°C (9° F) lower.
The outlet temperature of the cooling air must not exceed: t_{OUT, MAX} 45° C (113° F).
2. Calculate the permissible difference between the temperature of the cooling air (t_{IN}) and its outlet temperature (t_{OUT}):
Δ t= 45° C (113° F) -t_{IN}.
3. Calculate the required

$$quantity\ of\ air = \frac{\sum P_{\phi} \times 3.1}{\Delta t} m^3/h$$

Insert Δ t in Kelvin

The outlet from the ventilation must be placed above the highest-mounted frequency converter.
Allowance must be made for the pressure loss across the filters and for the fact that the pressure is going to drop as the filters are choked.

■ **EMC-correct electrical installation**

525-600 V units do not comply with European EMC and Low Voltage Directives.

The following is a guideline to good engineering practice, when installing drives. Following these guidelines is advised, where compliance with EN 50081, EN 55011 or EN 61800-3 *First environment* is required. If the installation is in EN 61800-3 *Second environment*, then it is acceptable to deviate from these guidelines. It is however not recommended. See also *CE labelling, Emission and EMC test results* in this manual.

Good engineering practice to ensure EMC-correct electrical installation:

- Use only braided screened/armoured motor cables and braided screened/armoured control cables. The screen should provide a minimum coverage of 80%. The screen material must be metal, not limited to but typically copper, aluminium, steel or lead. There are no special requirements for the mains cable.
- Installations using rigid metal conduits are not required to use screened cable, but the motor cable must be installed in conduit separate from the control and mains cables. Full connection of the conduit from the drive to the motor is required. The EMC performance of flexible conduits varies a lot and information from the manufacturer must be obtained.
- Connect the screen/armour/conduit to earth at both ends for motor cables as well as for control cables. See also *Earthing of braided screened/armoured control cables*.
- Avoid terminating the screen/armour with twisted ends (pigtailed). Such a termination increases the high frequency impedance of the screen, which reduces its effectiveness at high frequencies. Use low impedance cable clamps or EMC cable glands instead.
- It is important to have good electrical contact between the mounting plate on which the frequency converter is installed and the metal chassis of the frequency converter unit.

Exception:

- IP54/NEMA 12 units designed for wall mounting
- VLT 8152-8600 (380-480 V) IP20/NEMA 1
- VLT 8042-8062 (200-240 V) IP20/NEMA 1

This however does not apply to IP54/NEMA 12 units as they are designed for wall mounting and VLT 8152-8600, 380-480 VAC and VLT 8042-8062, 200-240 VAC in IP20/NEMA 1 enclosure.

- Use starwashers and galvanically conductive installation plates to secure good electrical connections for IP00/Chassis and IP20/NEMA 1 installations.
- Avoid using unscreened/unarmoured motor or control cables inside cabinets housing the drive(s), whenever this can be avoided.
- An uninterrupted high frequency connection between the frequency converter and the motor is required for IP54/NEMA 12 units.

The next illustration shows an example of an EMC-correct electrical installation of an IP 20/NEMA 1 frequency converter; the frequency converter has been installed in a cabinet (enclosure) together with an output contactor and is connected to a PLC which, in this example, is installed in a separate cabinet. For IP 54/NEMA 12 units, VLT 8152-8600 (380-480 V) and VLT 8042-8062 (200-240 V) units in IP20/NEMA 1 enclosures; screened cables are connected by using EMC conduits to assure proper EMC performance. (See next illustration.)

Other ways of making the installation may give as good an EMC performance, provided the above engineering practice guidelines are followed.

Please note, that when the installation is not made according to these guidelines as well as when unscreened cables and control wires are used, some emission requirements are not complied with, although the immunity requirements are fulfilled.

Installation

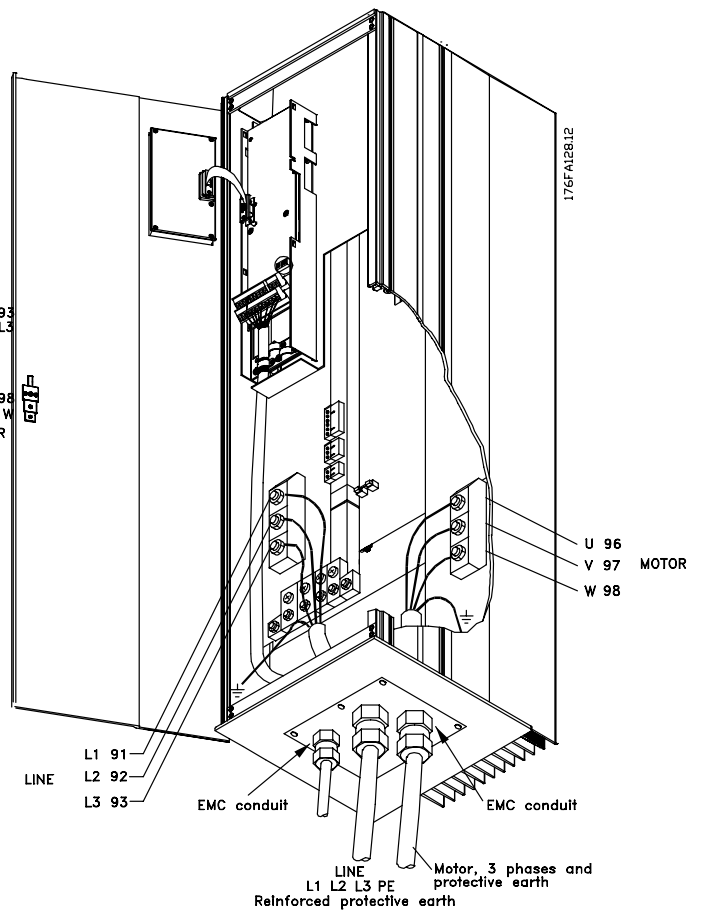
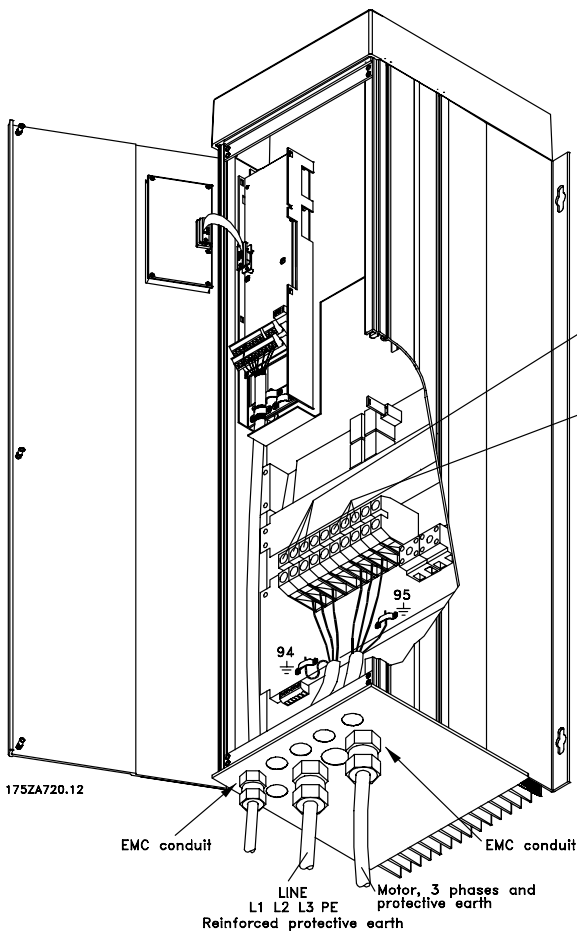
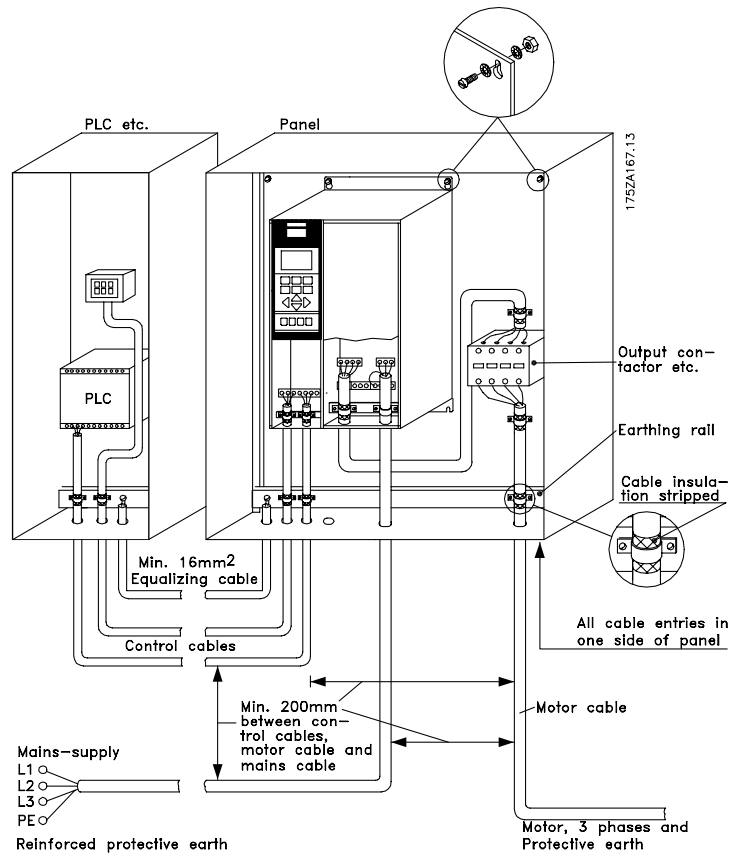

■ **Earthing/Grounding of screened/armoured control cables**

Generally speaking, control cables must be screened/ armoured and the screen must be connected by means of a cable clamp at both ends to the metal cabinet of the unit.

The drawing below indicates how correct earthing/grounding is carried out.

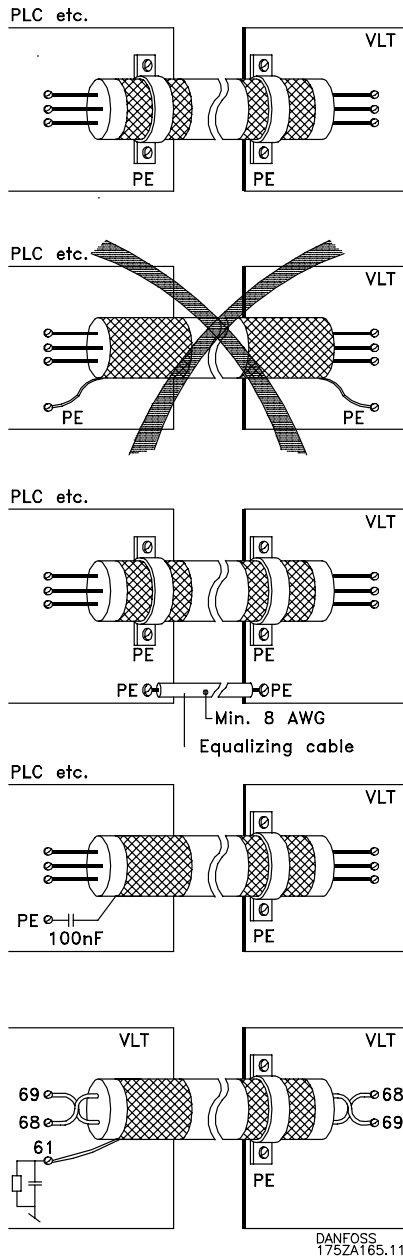

Correct earthing/grounding

Control cables and cables for serial communication must be fitted with cable clamps at both ends to ensure the best possible electrical contact.

Wrong earthing/grounding

Do not use twisted cable ends (pigtails), since these increase the screen impedance at high frequencies.

Protection with respect to earth potential between PLC and frequency converter

If the earth potential between the frequency converter and the PLC (etc.) is different, electric noise may occur that will disturb the whole system. This problem can be solved by fitting an equalizing cable, to be placed next to the control cable. Minimum cable cross-section: 8 AWG.

For 50/60 Hz earth loops

If very long control cables are used, 50/60 Hz earth loops may occur that will disturb the whole system. This problem can be solved by connecting one end of the screen to earth via an earth 100nF capacitor (keeping leads short).

Cables for serial communication

Low-frequency noise currents between two frequency converter can be eliminated by connecting one end of the screen to terminal 61. This terminal is connected to earth via an internal RC link. It is recommended to use twisted-pair cables to reduce the differential mode interference between the conductors.

Installation

■ Electrical installation, enclosures

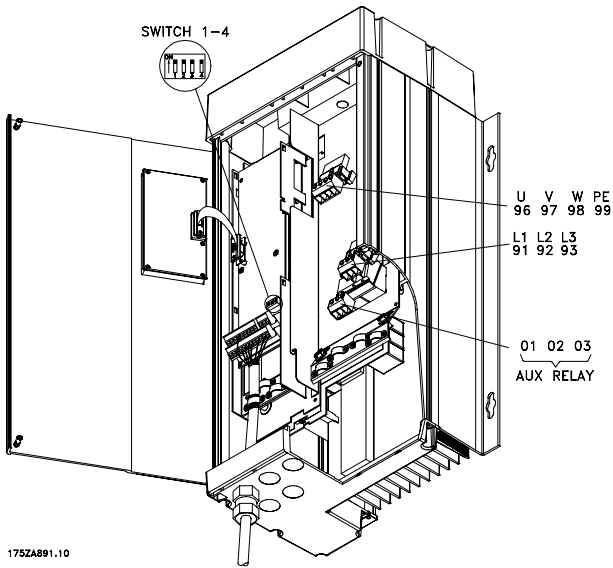

Compact IP 54/NEMA 12
VLT 8006-8011, 380-480 V

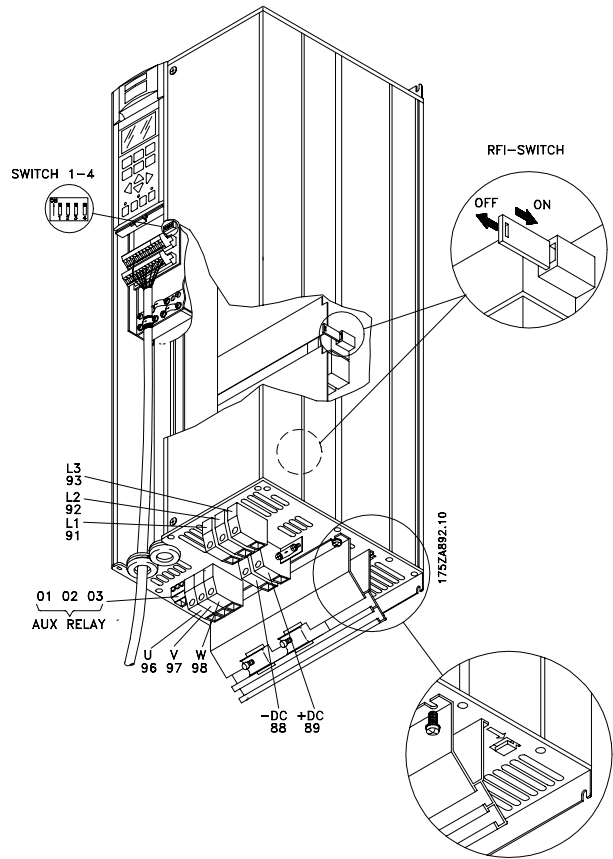

Compact IP 20/NEMA 1
VLT 8006-8032, 200-240 V
VLT 8016-8072, 380-480 V
VLT 8016-8072, 525-600 V

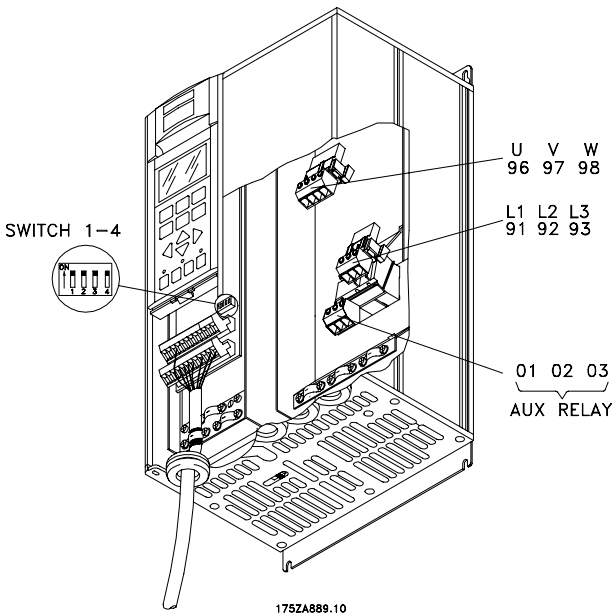

Compact IP 20/NEMA 1
VLT 8006-8011, 380-480 V
VLT 8002-8011, 525-600 V

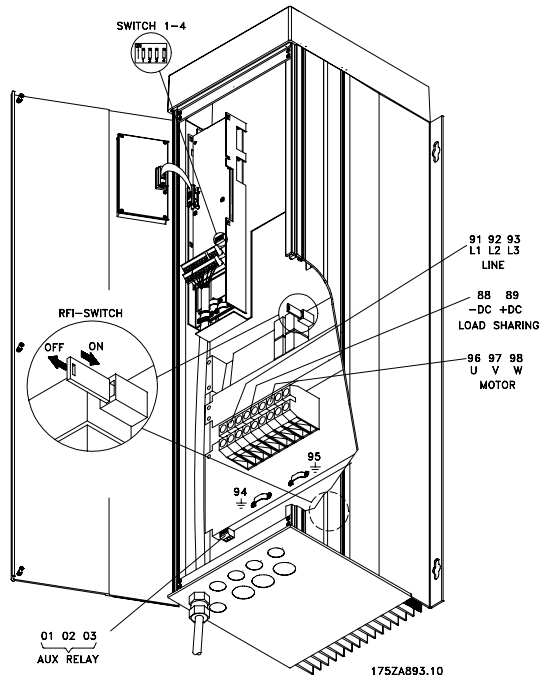

Compact IP 00/Chassis
VLT 8042-8062, 200-240 V

Compact IP 54/NEMA 12
VLT 8006-8032, 200-240 V
VLT 8016-8072, 380-480 V

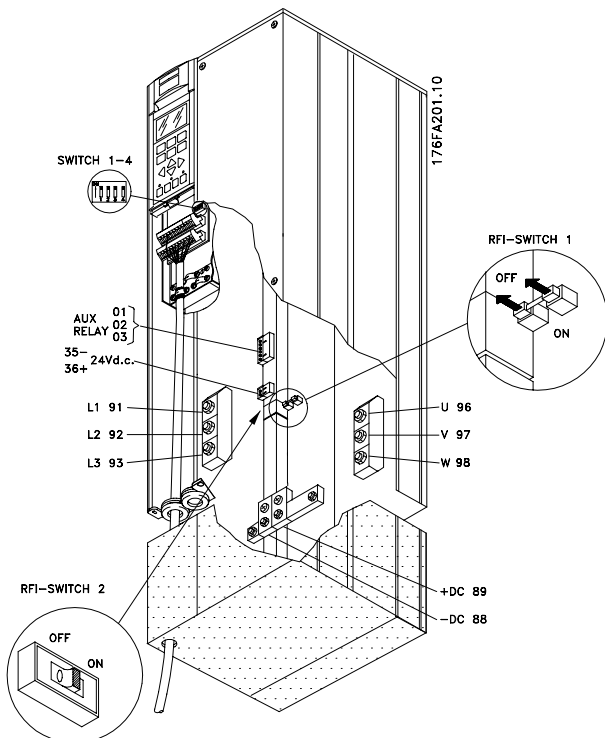

Compact IP 20/NEMA 1
VLT 8042-8062, 200-240 V

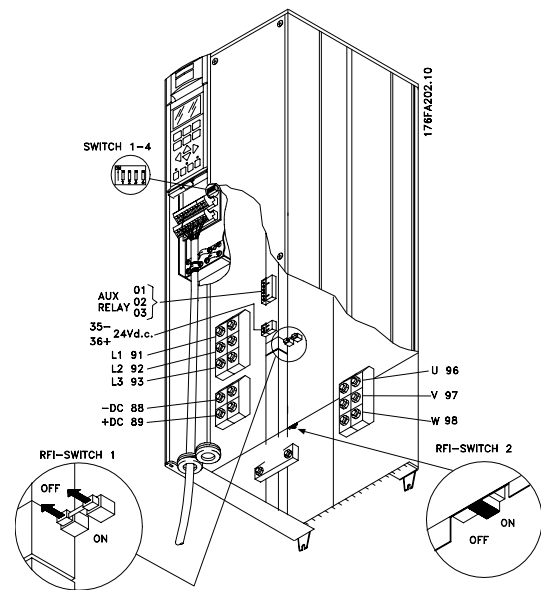

Compact IP 54/NEMA 12
VLT 8042-8062, 200-240 V

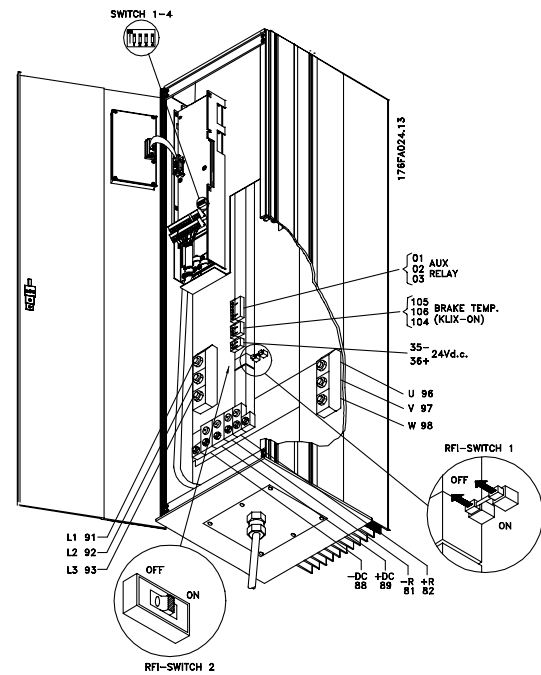

Compact IP 54/NEMA 12
VLT 8042-8062, 200-240 V

Installation

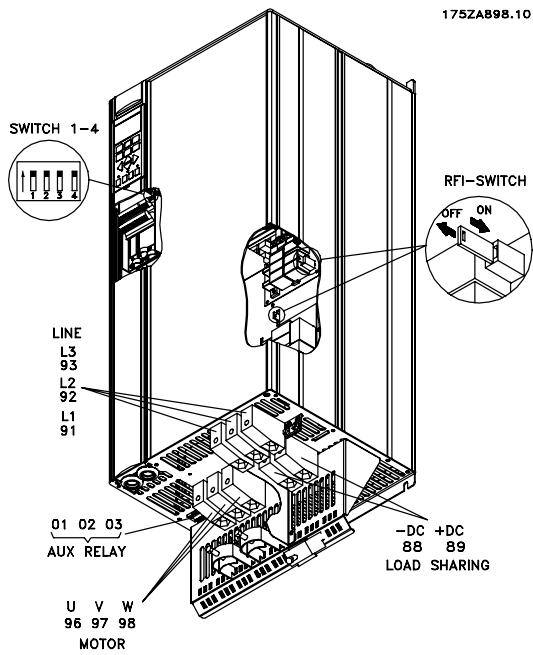

Compact IP 20/NEMA 1
VLT 8102-8122, 380-480 V

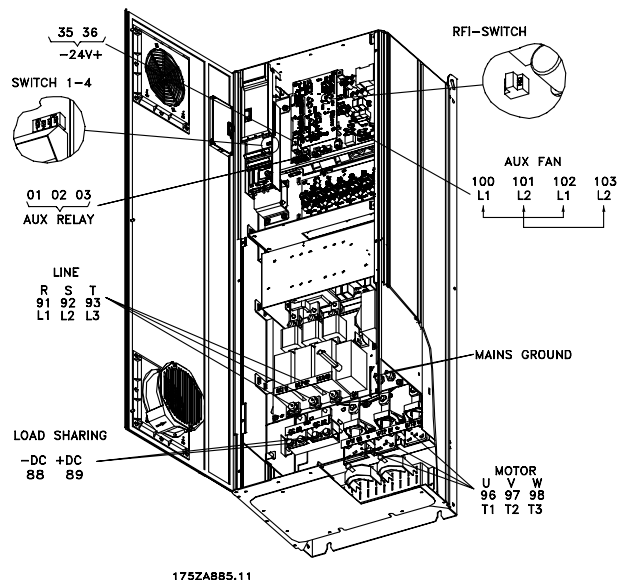

IP 54/NEMA 12, IP 21/NEMA 1
VLT 8152-8202, 380-480 V
VLT 8052-8202, 525-690 V

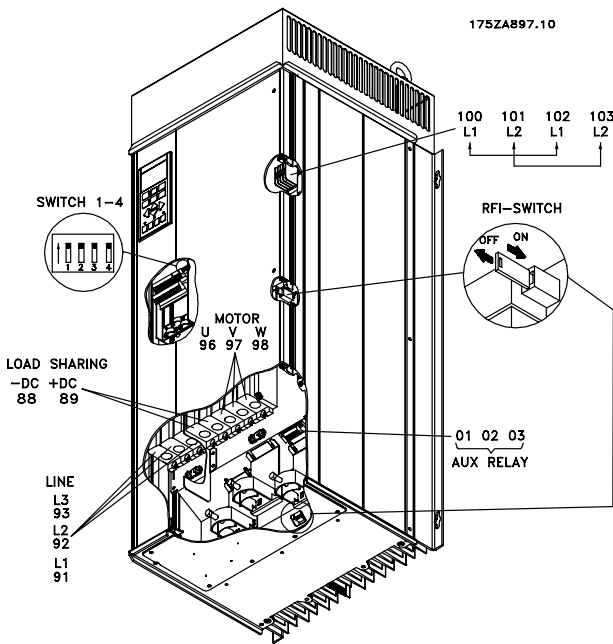

Compact IP 54/NEMA 12
VLT 8102-8122, 380-480 V

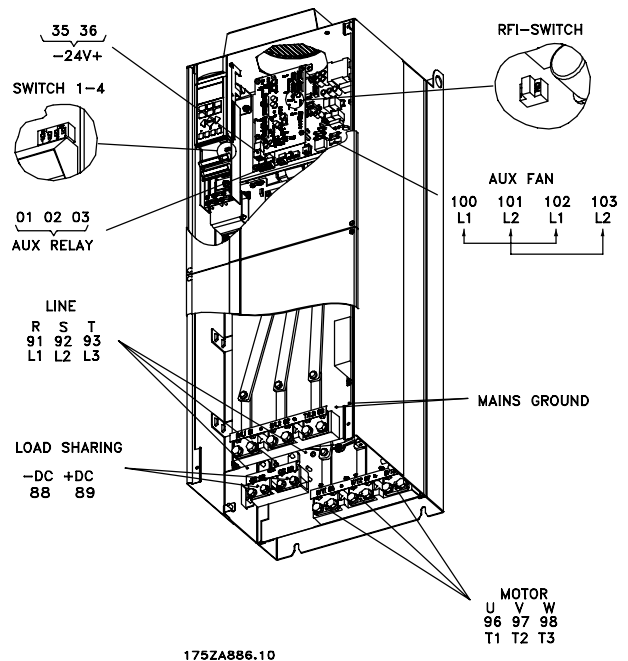

IP 00/Chassis
VLT 8152-8202, 380-480 V
VLT 8052-8202, 525-690 V

Note: The RFI switch has no function in the 525-690 V drives.

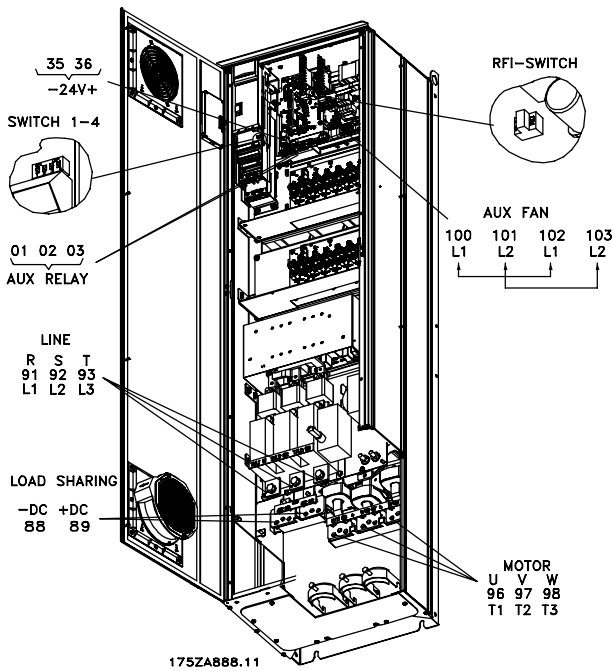

IP 54/NEMA 12, IP 21/NEMA 1 with disconnect and main fuse
VLT 8252-8352, 380-480 V
VLT 8252-8402, 525-690 V

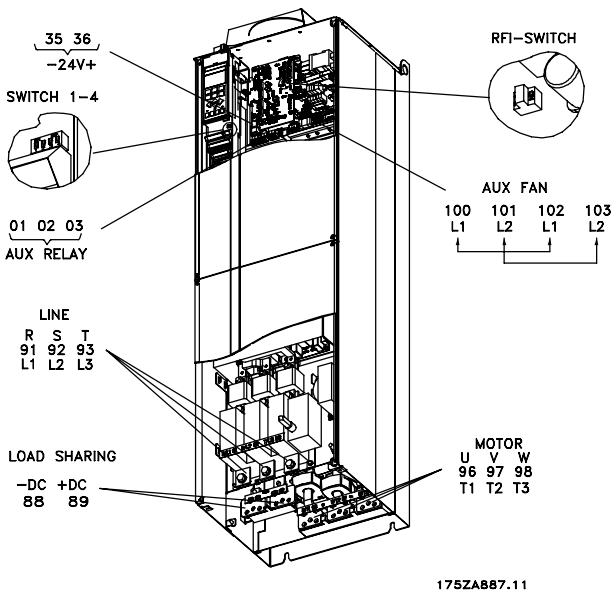

IP 00/Chassis with disconnect and main fuse
VLT 8252-8352, 380-480 V
VLT 8252-8402, 525-690 V

Note: The RFI switch has no function in the 525-690 V drives.

Installation

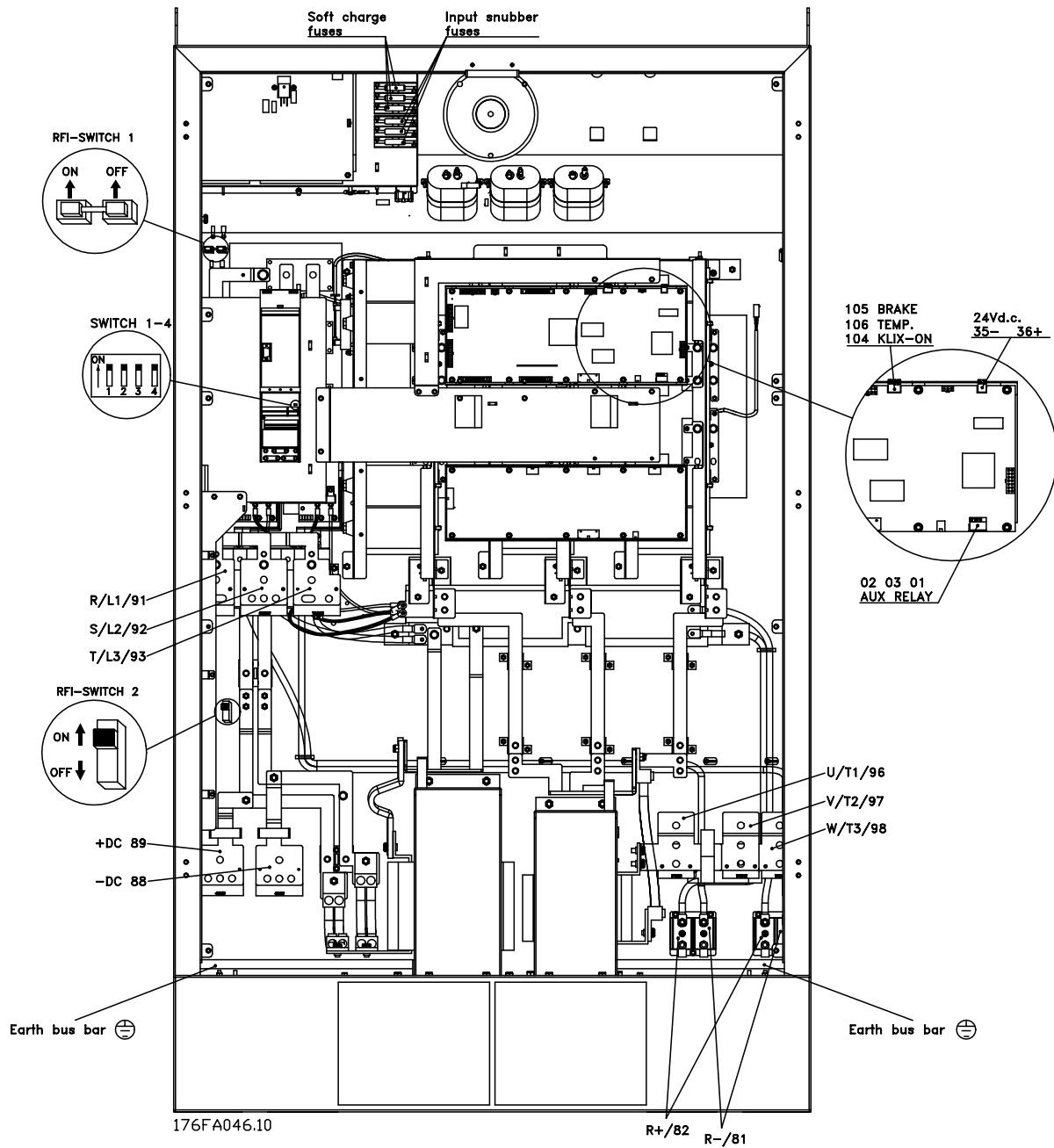

Compact IP 00/Chassis, IP 20/NEMA 1,
and IP 54/NEMA 12
VLT 8450-8600, 380-480 V

■ Electrical installation, power cables

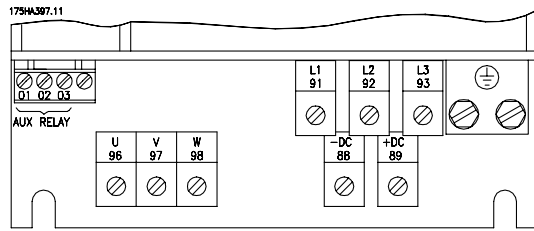

IP 20/NEMA 1

VLT 8006-8032, 200-240 V

VLT 8016-8122, 380-480 V

VLT 8016-8072, 525-600 V

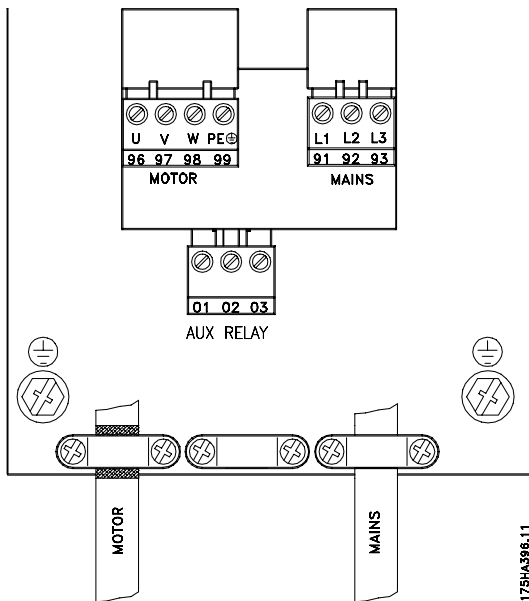

Installation

Compact IP 20/NEMA 1, and IP 54/NEMA 12

VLT 8006-8011, 380-480 V

VLT 8002-8011, 525-600 V

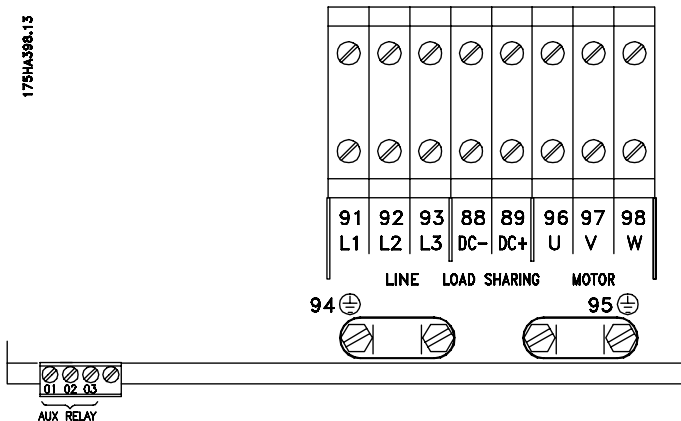

IP 54/NEMA 12

VLT 8006-8032, 200-240 V

VLT 8016-8072, 380-480 V

■ Electrical installation, power cables

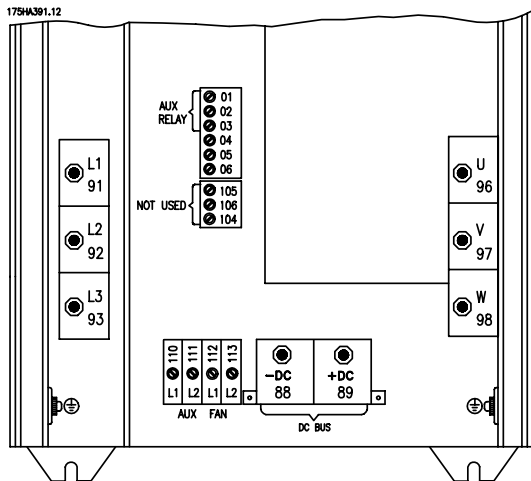

IP 00/Chassis and IP 20/NEMA 1
VLT 8042-8062, 200-240 V

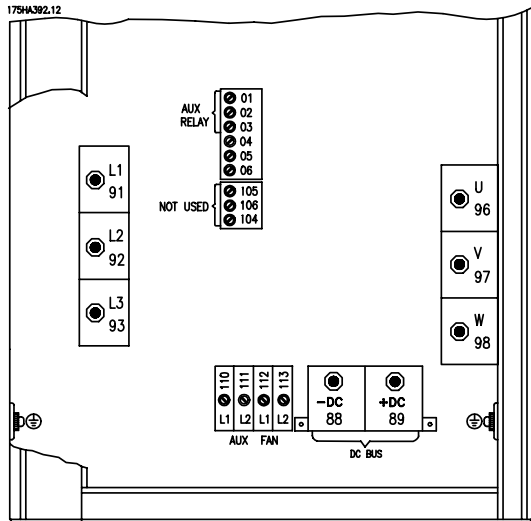

IP 54/NEMA 12
VLT 8042-8062, 200-240 V

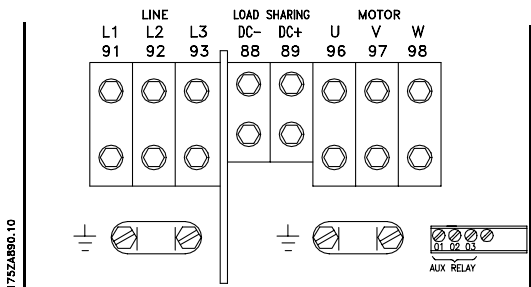

Compact IP 54 /NEMA 12
VLT 8102-8122, 380-480 V

■ Electrical installation, power cables

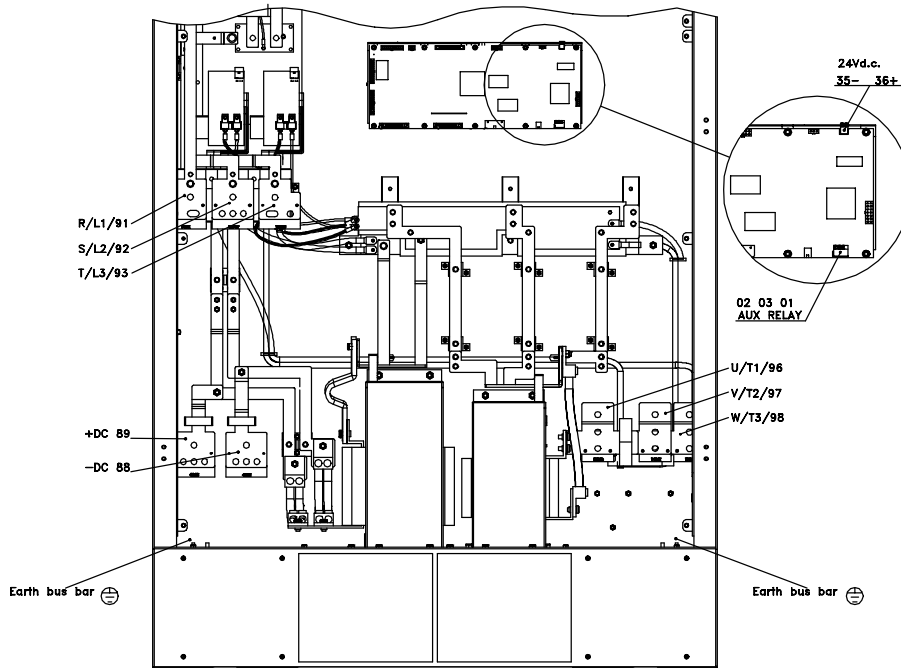

176FA203.10

Compact IP 00/Chassis, IP 20/NEMA 1, and IP 54/NEMA 12
 VLT 8450-8600 380-480 V without disconnectors and mains fuses

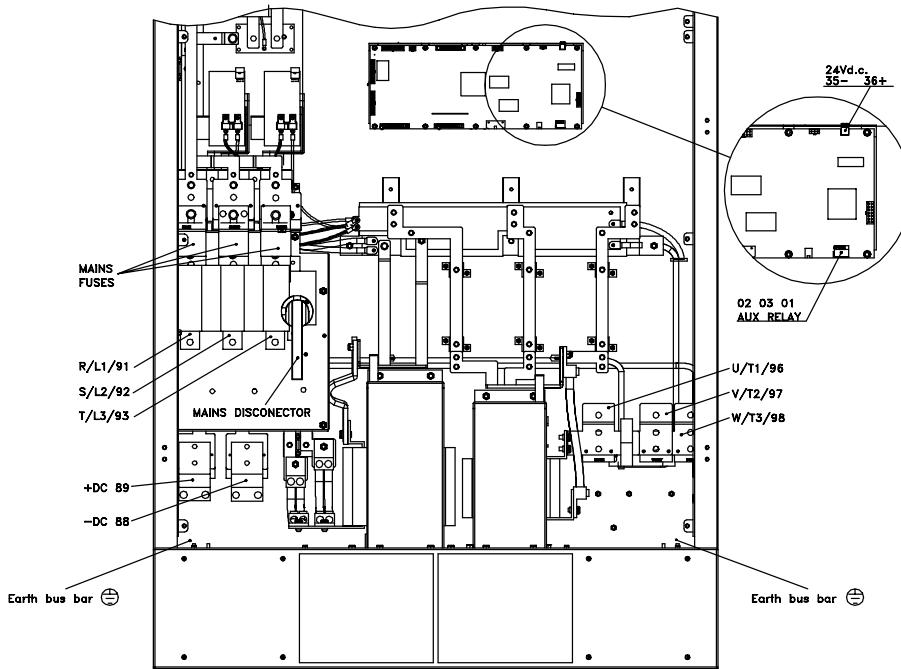

176FA204.10

Compact IP 00/Chassis, IP 20/NEMA 1, and IP 54/NEMA 12
 VLT 8450-8600 380-480 V with disconnectors and mains fuses

Installation

■ Use of emc-correct cables

Braided screened/armoured cables are recommended to optimise EMC immunity of the control cables and the EMC emission from the motor cables.

The ability of a cable to reduce the in- and outgoing radiation of electric noise depends on the transfer impedance (Z_T). The screen of a cable is normally designed to reduce the transfer of electric noise; however, a screen with a lower transfer impedance (Z_T) value is more effective than a screen with a higher transfer impedance (Z_T).

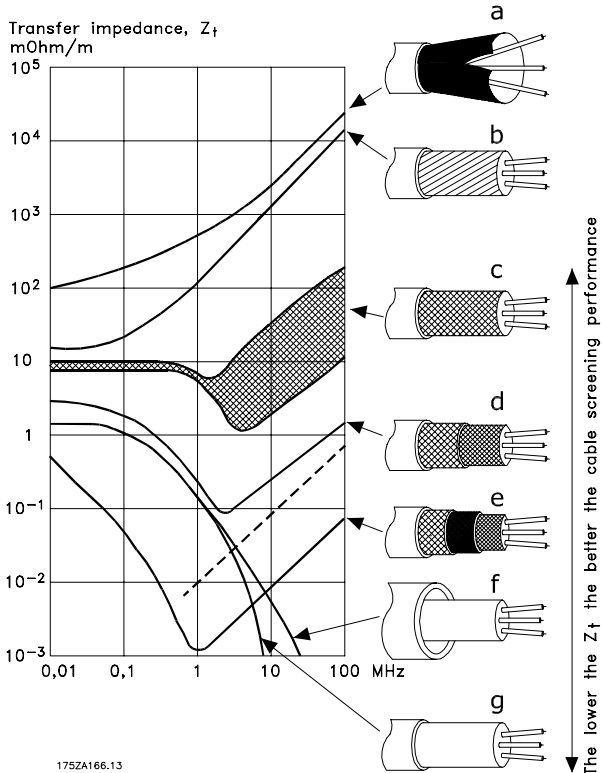

Transfer impedance (Z_T) is rarely stated by cable manufacturers, but it is often possible to estimate transfer impedance (Z_T) by assessing the physical design of the cable.

Transfer impedance (Z_T) can be assessed on the basis of the following factors:

- The conductivity of the screen material.
- The contact resistance between the individual screen conductors.
- The screen coverage, i.e. the physical area of the cable covered by the screen - often stated as a percentage value.
- Screen type, i.e. braided or twisted pattern.

Aluminium-clad with copper wire.

Twisted copper wire or armoured steel wire cable.

Single-layer braided copper wire with varying percentage screen coverage.
This is the typical Danfoss reference cable.

Double-layer braided copper wire.

Twin layer of braided copper wire with a magnetic, screened/armoured intermediate layer.

Cable that runs in copper tube or steel tube.

Lead cable with 1.1 mm wall thickness.

■ Tightening torque and screw sizes

The table shows the torque required when fitting terminals to the frequency converter. For VLT 8006-8032, 200-240 V; VLT 8006-8122, 380-480 and 525-600 V the cables must be fastened with screws. For VLT 8042-8062, 200-240 V; VLT 8152-8600, 380-480 V and VLT 8052-8402, 525-690 V, the cables must be fastened with bolts.

These figures apply to the following terminals:

Mains terminals (Nos.)	91, 92, 93 L1, L2, L3
Motor terminals (Nos.)	96, 97, 98 U, V, W
Earth terminal (Nos.)	94, 95, 99

VLT type	Tightening-up torque	Screw/bolt size	Allen key size
3 x 200-240 V			
VLT 8006-8011	16 in-lbs/1.8 Nm (IP 20)	M4	
VLT 8006-8016	16 in-lbs/1.8 Nm (IP 54)	M4	
VLT 8016-8027	26.6 in-lbs/3.0 Nm (IP 20)	M5 ³⁾	4 mm/0.16 in
VLT 8022-8027	26.6 in-lbs/3.0 Nm (IP 54) ²⁾	M5 ³⁾	4 mm/0.16 in
VLT 8032	53 in-lbs/6.0 Nm	M6 ³⁾	5 mm/0.20 in
VLT 8042-8062	100 in-lbs/11.3 Nm	M8 (bolt)	

VLT type	Tightening-up torque	Screw/bolt size	Allen key size
3 x 380-480 V			
VLT 8006-8011	5.3 in-lbs/0.5-0.6 Nm	M3	
VLT 8016-8027	16 in-lbs/1.8 Nm (IP 20)	M4	
VLT 8016-8032	16 in-lbs/1.8 Nm (IP 54)	M4	
VLT 8032-8052	26.6 in-lbs/3.0 Nm (IP 20)	M5 ³⁾	4 mm/0.16 in
VLT 8042-8052	26.6 in-lbs/3.0 Nm (IP 54) ²⁾	M5 ³⁾	4 mm/0.16 in
VLT 8062-8072	53 in-lbs/6.0 Nm	M6 ³⁾	5 mm/0.20 in
VLT 8102-8122	133 in-lbs/15 Nm (IP 20)	M8 ³⁾	6 mm/0.24 in
	213 in-lbs/24 Nm (IP 54) ¹⁾	³⁾	8 mm/0.31 in
VLT 8152-8352	168 in-lbs/19 Nm ⁴⁾	M10 (bolt)	
VLT 8450-8600	372 in-lbs/42 Nm	M12 (bolt)	

VLT type	Tightening-up torque	Screw/bolt size	Allen key size
3 x 525-600 V			
VLT 8002-8011	5.3 in-lbs/0.5-0.6 Nm	M3	
VLT 8016-8027	16 in-lbs/1.8 Nm	M4	
VLT 8032-8042	26.6 in-lbs/3.0 Nm ²⁾	M5 ³⁾	4 mm/0.16 in
VLT 8052-8072	53 in-lbs/6.0 Nm	M6 ³⁾	5 mm/0.20 in

VLT type	Tightening-up torque	Screw/bolt size	Allen key size
3 x 525-690 V			
VLT 8052-8402	168 in-lbs/19 Nm ⁴⁾	M10 (bolt)	

1. Loadsharing terminals 14 Nm/M6, 5 mm/0.20 in Allen key
2. IP 54 units with RFI filter mains terminals 6 Nm
3. Allen screws (hexagon)
4. Loadsharing terminals 84 in-lbs/9.5 Nm/M8 (bolt)

Installation

■ Mains connection

Mains must be connected to terminals 91, 92, 93.

Nos. 91, 92, 93	Mains voltage 3 x 200-240 V
L1, L2, L3	Mains voltage 3 x 380-480 V
	Mains voltage 3 x 525-600 V
	Mains voltage 3 x 525-690 V

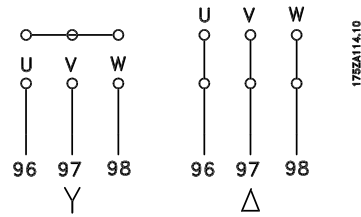

NB!:

Check that the mains voltage corresponds to the mains voltage of the frequency converter, which can be seen from the nameplate.

See *Technical data* for correct sizing of cable cross-sections.



NB!:

It is the responsibility of the user or installer to ensure that proper earthing, branch circuit, and motor overload protection is in accordance with national and local electrical and safety regulations and codes.

■ Motor connection

The motor must be connected to terminals 96, 97, 98. Earth to terminal 94/95/99.

Nos.	
96, 97, 98	Motor voltage 0-100 % of mains voltage
U, V, W	
No. 94/95/99	Earth connection

See *Technical data* for correct sizing of cable cross-sections.

All types of three-phase asynchronous standard motors can be used with a VLT 8000 AQUA unit.

Small-size motors are normally star-connected. (220/380 V, Δ/Y). Large-size motors are delta-connected (380/660 V, Δ/Y). The correct connection and voltage can be read from the motor nameplate.



NB!:

In older motors without phase coil insulation, a LC filter should be fitted to the frequency converter output.

■ Direction of IEC motor rotation

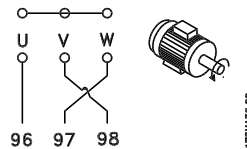
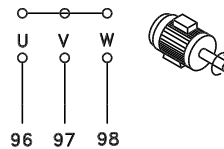

The factory setting is for clockwise rotation with the VLT frequency transformer output connected as follows.

Terminal 96 connected to U-phase
Terminal 97 connected to V-phase
Terminal 98 connected to W-phase

The direction of rotation can be changed by switching two phases in the motor cable.

■ Parallel coupling of motors

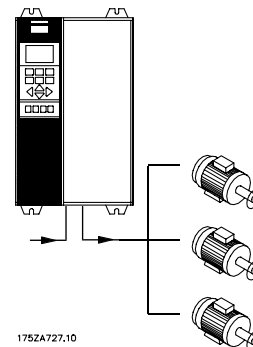

VLT 8000 AQUA is able to control several motors connected in parallel. If the motors are to have different rpm values, the motors must have different rated rpm values. Motor rpm is changed simultaneously, which means that the ratio between the rated rpm values is maintained across the range.

The total current consumption of the motors is not to exceed the maximum rated output current $I_{VLT,N}$ for the frequency converter.

Problems may arise at the start and at low rpm values if the motor sizes are widely different. This is because

the relatively high ohmic resistance in small motors calls for a higher voltage at the start and at low rpm values.

In systems with motors connected in parallel, the electronic thermal relay (ETR) of the frequency converter cannot be used as motor protection for the individual motor. Consequently, additional motor protection is required, such as thermistors in earth motor (or individual thermal relays).

NB!
 Parameter 107 *Automatic Motor Adaptation*, *AMA* and *Automatic Energy Optimization*, *AEO* in parameter 101 *Torque characteristics* cannot be used motors are connected in parallel.

■ Motor cables

See *Technical data* for correct sizing of motor cable cross-section and length. Always comply with national and local regulations on cable cross-sections.

NB!
 If an unscreened cable is used, some EMC requirements are not complied with, see *EMC test results*.

If the EMC specifications regarding emission are to be complied with, the motor cable must be screened, unless otherwise stated for the RFI filter in question. It is important to keep the motor cable as short as possible so as to reduce the noise level and leakage currents to a minimum. The motor cable screen must be connected to the metal cabinet of the frequency converter and to the metal cabinet of the motor. The screen connections are to be made with the biggest possible surface (cable clamp). This is enabled by different installation devices in the different frequency converters. Mounting with twisted screen ends (pigtails) is to be avoided, since these spoil the screening effect at higher frequencies. If it is necessary to break the screen to install a motor isolator or motor contactor, the screen must be continued at the lowest possible HF impedance.

■ Motor thermal protection

The electronic thermal relay in UL-approved frequency converter has received UL-approval for single motor protection, as long as parameter 117 *Motor thermal protection* has been set to ETR Trip and parameter 105 *Motor current*, $I_{VLT,N}$ has been

programmed for the rated motor current (can be read from the motor nameplate).

■ Earth connection

Since the leakage currents to earth may be higher than 3.5 mA, the frequency converter must always be earthed in accordance with applicable national and local regulations. In order to ensure good mechanical connection of the earth cable, its cable cross-section must be at least 8 AWG/10mm². For added security, an RCD (Residual Current Device) may be installed. This ensures that the frequency converter will cut out if the leakage currents get too high. See RCD Instructions MI.66.AX.02.

■ Installation of 24 Volt external DC supply

Torque: 0.5 - 0.6 Nm
 Screw size:

M3

No.	Function
35(-), 36 (+)	24 V External DC supply (Available with VLT 8016-8600 380-480 V and VLT 8052-8402 525-690 V only)

24 V external DC supply can be used as low-voltage supply to the control card and any option cards installed. This enables full operation of the LCP (incl. parameter setting) without connection to mains. Please note that a warning of low voltage will be given when 24 V DC has been connected; however, there will be no tripping. If 24 V external DC supply is connected or switched on at the same time as the mains supply, a time of min. 200 msec. must be set in parameter 111, *Start delay*. A pre-fuse of min. 6 Amp, slow-blow, can be fitted to protect the external 24 V DC supply. The power consumption is 15-50 W, depending on the load on the control card.

NB!
 Use 24 V DC supply of type PELV to ensure correct galvanic isolation (type PELV) on the control terminals of the frequency converter.

■ DC bus connection

The DC bus terminal is used for DC back-up, with the intermediate circuit being supplied from an external DC source.

Terminal nos.

Nos. 88, 89

Contact Danfoss if you require further information.

■ High-voltage relay

The cable for the high-voltage relay must be connected to terminals 01, 02, 03. The high-voltage relay is programmed in parameter 323, *Relay 1, output*.

No. 1	Relay output 1 1+3 break, 1+2 make. Max. 240 V AC, 2 Amp. Min. 24 V DC, 10 mA or 24 V AC, 100 mA.
-------	---

Max. cross-section: 4 mm² /10 AWG.
Torque: 0.5 Nm/5 in-lbs
Screw size: M3

■ Control card

All terminals for the control cables are located under the protective cover of the frequency converter. The protective cover (see drawing below) can be removed by means of a pointed object (except IP54/NEMA 12 units) - a screwdriver or similar.

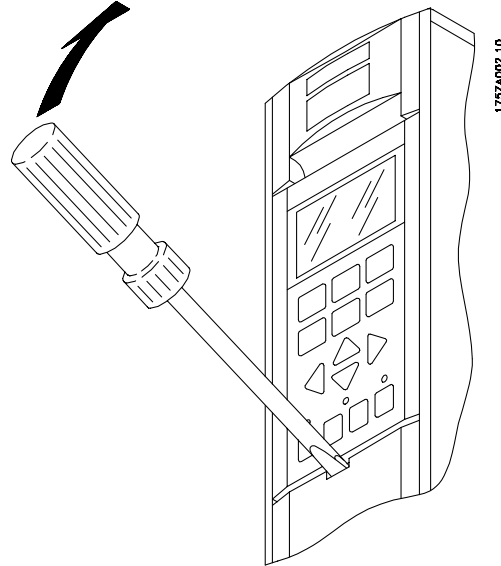

■ Electrical installation, control cables

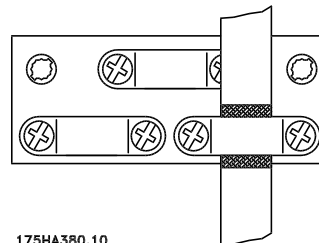

Torque: 0.5 Nm (5 in-lbs)
Screw size: M3.

Generally speaking, control cables must be screened/armoured and the screen must be connected by means of a cable clamp at both ends to the metal cabinet of the unit (see *Earthing/Grounding of screened (armoured control cables)*).

Normally, the screen must also be connected to the body of the controlling unit (follow the instructions for installation given for the unit in question).

If very long control cables are used, 50/60 Hz earth loops may occur that will disturb the whole system. This problem can be solved by connecting one end of the screen to earth via a 100nF capacitor (keeping leads short).

■ Electrical installation, control cables

Torque: 0.5 Nm/5 in-lbs

Screw size: M3

See *Earthing/Grounding of screened (armoured control cables)* for correct termination of control cables.

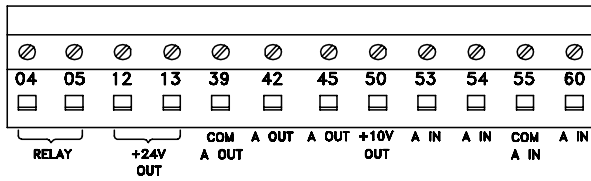
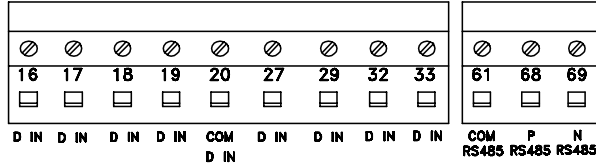

175HA379.10

No.	Function
04, 05	Relay output 2 can be used for indicating status and warnings.
12, 13	Voltage supply to digital inputs. For the 24 V DC to be used for digital inputs, switch 4 on the control card must be closed, position "on".
16-33	Digital inputs. See parameters 300-307 <i>Digital inputs</i> .
20	Common for digital inputs.
39	Common for analog/digital outputs. See <i>Examples of connection</i> .
42, 45	Analog/digital outputs for indicating frequency, reference, current and torque. See parameters 319-322 <i>Analog/digital outputs</i> .
50	Supply voltage to potentiometer and thermistor 10 V DC.
53, 54	Analog voltage input, 0 - 10 V DC.
55	Common for analog inputs.
60	Analog current input 0/4-20 mA. See parameters 314-316 <i>Terminal 60</i> .
61	Termination of serial communication. See <i>Earthing/Grounding of screened (armoured control cables)</i> . This terminal is not normally to be used.

68, 69

RS 485 interface, serial communication. When multiple frequency converters are connected to a communication bus, switches 2 and 3 on control card in the first and last units must be closed (position ON). For the remaining frequency converters, switches 2 and 3 must be open (OFF). The factory setting is closed (position ON).

■ Switches 1-4

The dipswitch is located on the control card. It is used for serial communication and external DC supply. The switching position shown is the factory setting.



Switch 1 has no function.

Switches 2 and 3 are used for terminating an RS 485 interface, serial communication. In the first and the last frequency converter, switches 2 and 3 must be ON. In the other frequency converter, switches 2 and 3 must be OFF.

Switch 4 is used if an external 24 V DC supply is required for the control terminals. Switch 4 separates the common potential for the internal 24 V DC supply from the common potential of the external 24 V DC supply.



NB!:

Please note that when Switch 4 is in position "OFF", the external 24 V DC supply is galvanically isolated from the frequency converter.

Installation

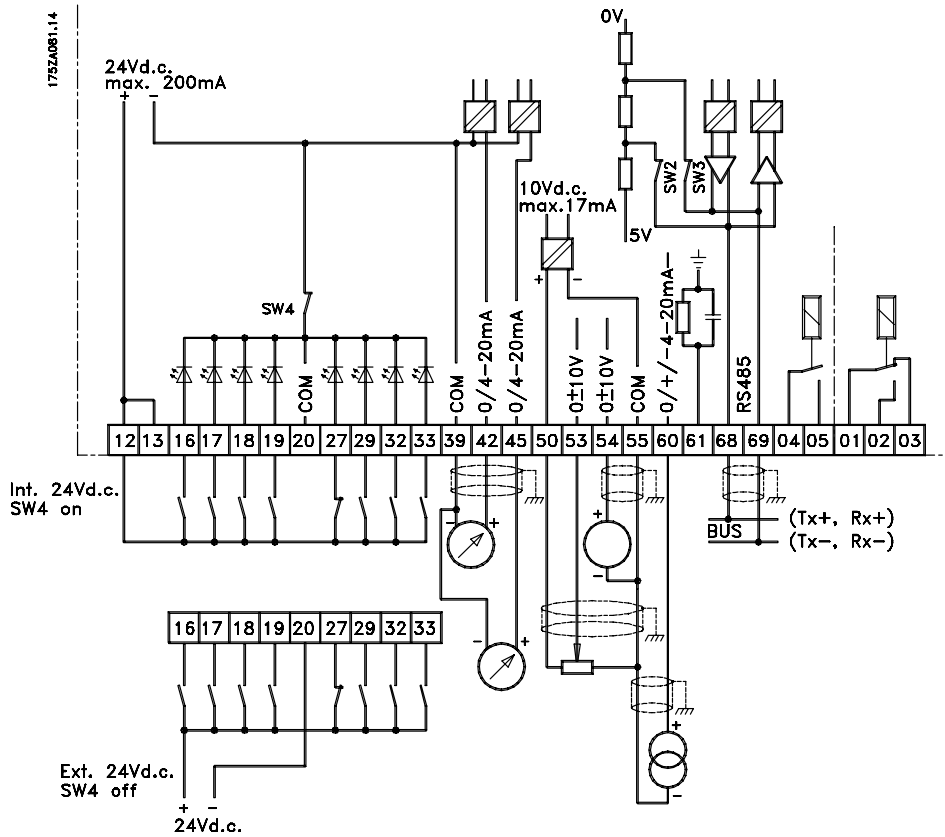

■ Bus connection

The serial bus connection in accordance with the RS 485 (2-conductor) norm is connected to terminals 68/69 of the frequency converter (signals P and N). Signal P is the positive potential (TX+,RX+), while signal N is the negative potential (TX-,RX-).

If more than one frequency converter is to be connected to a given master, use parallel connections.

In order to avoid potential equalizing currents in the screen, the cable screen can be earthed via terminal 61, which is connected to the frame via an RC-link.

Bus termination

The bus must be terminated by a resistor network at both ends. For this purpose, set switches 2 and 3 on the control card for "ON".

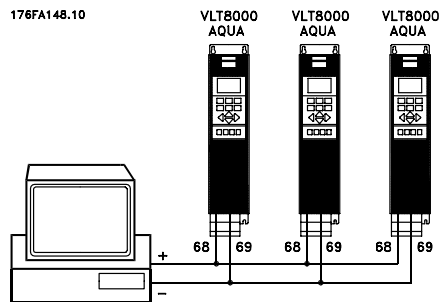

■ Connection example VLT 8000 AQUA

The diagram below gives an example of a typical VLT 8000 AQUA installation.

The mains supply is connected to terminals 91 (L1), 92 (L2) and 93 (L3), while the motor is connected to 96 (U), 97 (V) and 98 (W). These numbers can also be seen from the terminals of the frequency converter.

An external DC supply can be connected to terminals 88 and 89.

Analogue inputs can be connected to terminals 53 [V], 54 [V] and 60 [mA]. These inputs can be programmed for either reference, feedback or thermistor. See *Analogue inputs* in parameter group 300.

There are 8 digital inputs, which are controlled with 24 V DC. Terminals 16-19, 27, 29, 32, 33. These inputs can be programmed in accordance with the table in *Inputs and outputs 300-328*.

There are two analogue/digital outputs (terminals 42 and 45), which can be programmed to show the present status or a process value, such as 0- f_{MAX} . Relay outputs 1 and 2 can be used for giving the present status or a warning.

On terminals 68 (P+) and 69 (N-) RS 485 interface, the frequency converter can be controlled and monitored via serial communication.

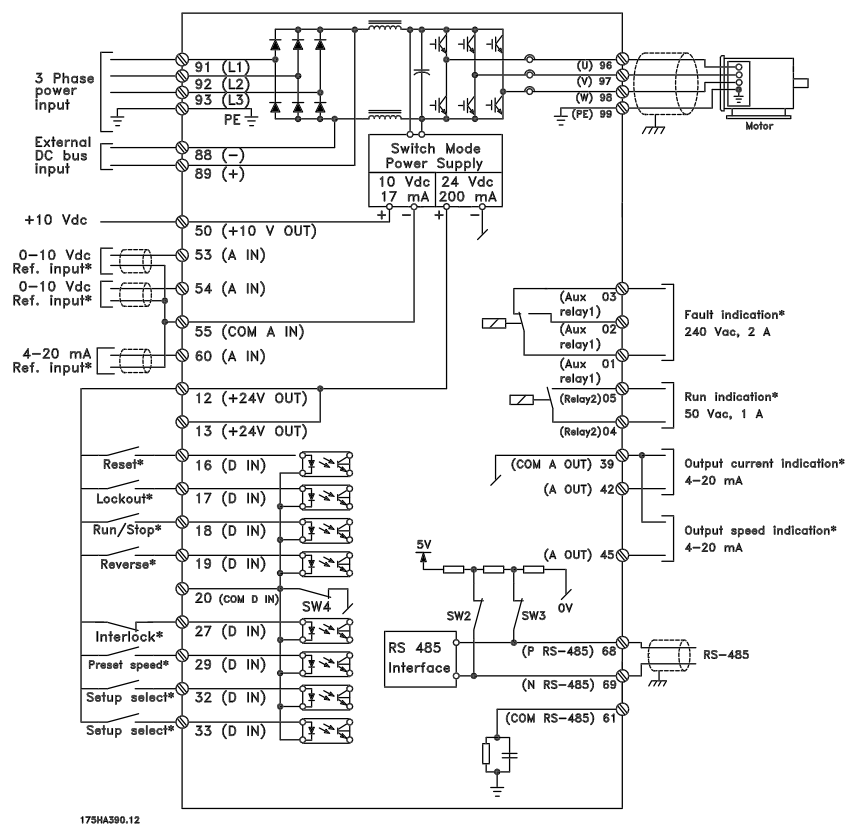

* These terminals can be programmed for other functions.

■ Connection examples

■ Single-pole start/stop

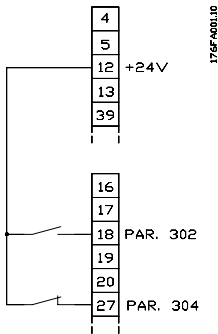

- Start/stop using terminal 18.
Parameter 302 = *Start* [1]
- Quick-stop using terminal 27.
Parameter 304 = *Coasting stop, inverse* [0]

■ Run permissive

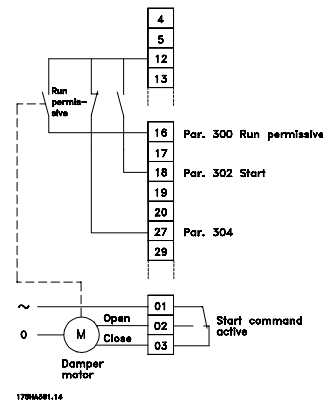

- Start permitted with terminal 16.
Parameter 300 = *Run permissive* [8].
- Start/stop with terminal 18.
Parameter 302 = *Start* [1].
- Quickstop with terminal 27.
Parameter 304 = *Coasting stop, inverse* [0].
- Activated peripheral equip
Parameter 323 = *Start command active* [13].

■ Digital speed up/down

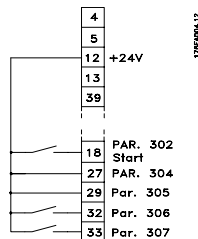

- Speed up and down using terminals 32 and 33.
Parameter 306 = *Speed up* [7]
Parameter 307 = *Speed down* [7]
Parameter 305 = *Freeze reference* [2]

■ 2-zone regulation

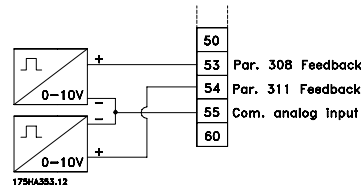

- Parameter 308 = *Feedback* [2].
- Parameter 311 = *Feedback* [2].

■ Potentiometer reference

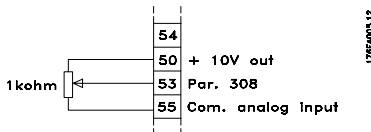

- Parameter 308 = *Reference* [1]
Parameter 309 = *Terminal 53, min. scaling*
Parameter 310 = *Terminal 53, max. scaling*

■ Transmitter connection

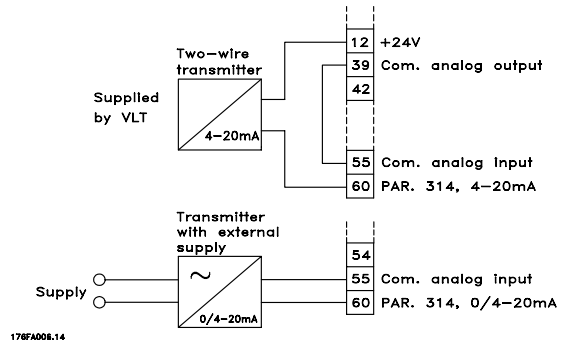

- Parameter 314 = *Reference* [1]
- Parameter 315 = *Terminal 60, min. scaling*
- Parameter 316 = *Terminal 60, max. scaling*

■ 3-wire start/stop

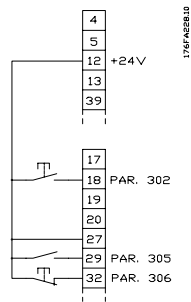

- Stop inverse by means of terminal 32.
Parameter 306 = *Stop inverse*[14]
- Latched start using terminal 18.
Parameter 302 = *Latched start* [2]
- Jog by means of terminal 29.
Parameter 305 = *Jog* [12]

■ Control unit LCP

The front of the frequency converter features a control panel - LCP (Local Control Panel). This is a complete interface for operation and programming of the VLT 8000 AQUA. The control panel is detachable and can - as an alternative - be installed up to 3m/10 ft away from the frequency converter, e.g. on the front panel, by means of a mounting kit option.

The functions of the control panel can be divided into five groups:

1. Display
2. Keys for changing display mode
3. Keys for changing program parameters
4. Indicator lamps
5. Keys for local operation.

All data are indicated by means of a 4-line alpha-numeric display, which, in normal operation, is able to show 4 operating data values and 3 operating condition values continuously. During programming, all the information required for quick, effective parameter Setup of the frequency converter will be displayed. As a supplement to the display, there are three indicator lamps for voltage (ON),

warning (WARNING) and alarm (ALARM), respectively. All frequency converter parameter Setups can be changed immediately via the control panel, unless this function has been programmed to be *Locked* [1] via parameter 016 *Lock for data change* or via a digital input, parameters 300-307 *Lock for data change*.

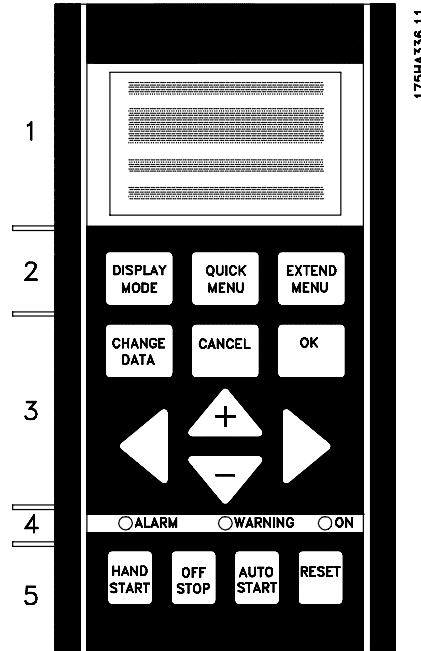

■ Control keys for parameter setup

The control keys are divided into functions. This means that the keys between display and indicator lamps are used for parameter Setup, including selecting the display indication during normal operation.

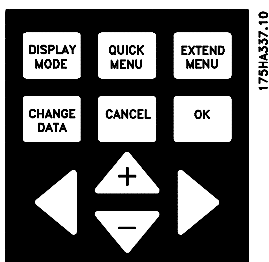

DISPLAY MODE

[DISPLAY MODE] is used for selecting the indication mode of the display or when returning to the Display mode from either the Quick menu or the Extend menu mode.

QUICK MENU

[QUICK MENU] gives access to the parameters used for the Quick menu. It is possible to switch between the Quick menu and the Extend menu modes.

EXTEND MENU

[EXTEND MENU] gives access to all parameters. It is possible to switch between the Extend menu and the Quick menu modes.

CHANGE DATA

[CHANGE DATA] is used for changing a setting selected either in the Extend menu or the Quick menu mode.

CANCEL

[CANCEL] is used if a change of the selected parameter is not to be carried out.

OK

[OK] is used for confirming a change of the parameter selected.

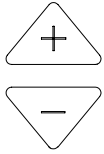

[+/-] is used for selecting parameters and for changing a chosen parameter. These keys are also used to change the local reference. In addition, the keys are used in Display mode to switch between operation variable readouts.

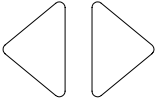

[<>] is used when selecting a parameter group and for moving the cursor when changing numerical values.

Indicator lamps

At the bottom of the control panel is a red alarm lamp and a yellow warning lamp, as well as a green voltage LED.

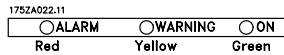

If certain threshold values are exceeded, the alarm and/ or warning lamp is activated, and a status or alarm text is displayed.



NB!

The voltage indicator lamp is activated when the frequency converter receives voltage.

Local control

Underneath the indicator lamps are keys for local control.

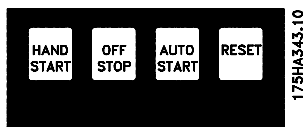

[HAND START] is used if the frequency converter is to be controlled via the control unit. The frequency converter will start the motor, since a start command is given by means of [HAND START].

On the control terminals, the following control signals will still be active when [HAND START] is activated:

- Hand start - Off stop - Auto start
- Safety Interlock
- Reset
- Coasting stop inverse
- Reversing
- Setup select lsb - Setup select msb
- Jog
- Run permissive
- Lock for data change
- Stop command from serial communication



NB!

If parameter 201 *Output frequency low limit* f_{MIN} is set to an output frequency greater than 0 Hz, the motor will start and ramp up to this frequency when [HAND START] is activated.



[OFF/STOP] is used for stopping the connected motor. Can be selected as Enable [1] or Disable [0] via parameter 013. If the stop function is activated, line 2 will flash.



[AUTO START] is used if the frequency converter is to be controlled via the control terminals and/or serial communication. When a start signal is active on the control terminals and/or the bus, the frequency converter will start.



NB!

An active HAND-OFF-AUTO signal via the digital inputs will have higher priority than the control keys [HAND START]-[AUTO START].



[RESET] is used for resetting the frequency converter after an alarm (trip). Can be selected as *Enable* [1] or *Disable* [0] via parameter 015 *Reset on LCP*.

See also *List of warnings and alarms*.

■ Display mode

In normal operation, any 4 different operating variables can be indicated continuously: 1.1 and 1.2 and 1.3 and 2. The present operating status or alarms and warnings that have arisen are shown in line 2 in the form of a number. In the case of alarms, the alarm in question will be shown in lines 3 and 4, accompanied by an explanatory note. Warnings will flash in line 2, with an explanatory note in line 1. In addition, the display shows the active Setup. The arrow indicates the direction of rotation; here the frequency converter has an active reversing signal. The arrow body disappears if a stop command is given or if the output frequency falls below 0.01 Hz. The bottom line gives the status of the frequency converter. The scroll list on the next page gives the operating data that can be shown for variable 2 in display mode. Changes are made via the [+/-] keys.



■ Display mode, cont.

Three operating data values can be shown in the first display line, while one operating variable can be shown in the second display line. To be programmed via parameters 007, 008, 009 and 010 *Display read-out*.

- Status line (4th line):

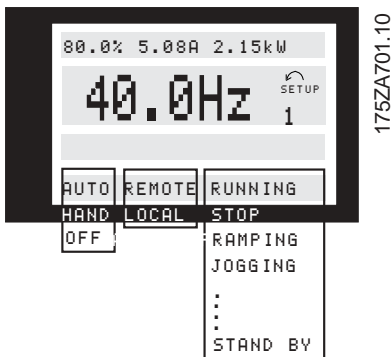

The left part of the status line indicates the control element of the frequency converter that is active. AUTO means that control is via the control terminals, while HAND indicates that control is via the local keys on the control unit.

OFF means that the frequency converter ignores all control commands and stops the motor.

The centre part of the status line indicates the reference element that is active. REMOTE means that the reference from the control terminals is active, while LOCAL indicates that the reference is determined via the [+/-] keys on the control panel.

The last part of the status line indicates the current status, for example "Running", "Stop" or "Alarm".

■ Display mode I

VLT 8000 AQUA offers different display modes depending on the mode selected for the frequency converter.

Below is a display mode, in which the frequency converter is in Auto mode with remote reference at an output frequency of 40 Hz.

In this display mode, reference and control are determined via the control terminals.

The text in line 1 gives the operating variable shown in line 2.

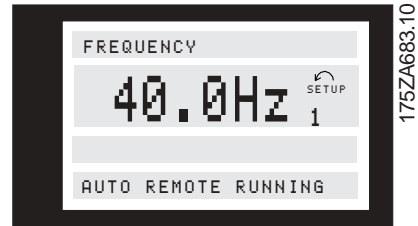

Line 2 gives the current output frequency and the active Setup.

Line 4 says that the frequency converter is in Auto mode with remote reference, and that the motor is running.

■ Display mode II:

This display mode makes it possible to have three operating data values displayed at the same time in line 1. The operating data values are determined in parameters 007-010 *Display readout*.

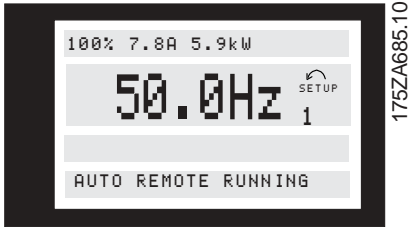

■ Display mode III:

This display mode is active as long as the [DISPLAY MODE] key is kept depressed. In the first line, operating data names and units of operating data are displayed. In the second line, operating data 2 remains unchanged. When the key is released, the different operating data values are shown.

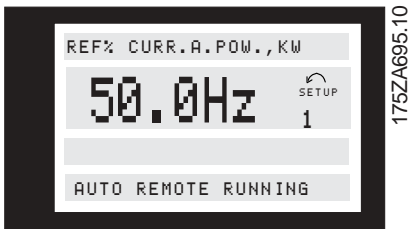

■ Display mode IV:

This display mode is only active in connection with local reference, see also *Reference handling*. In this display mode, the reference is determined via the [+/-] keys and control is carried out by means of the keys underneath the indicator lamps. The first line indicates the required reference. The third line gives the relative value of the present output frequency at any given time in relation to the maximum frequency. The display is in the form of a bar graph.

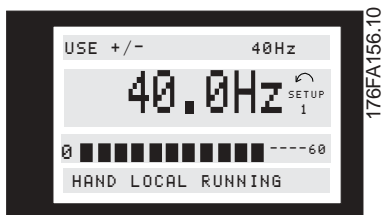

Installation

■ Navigation between display modes

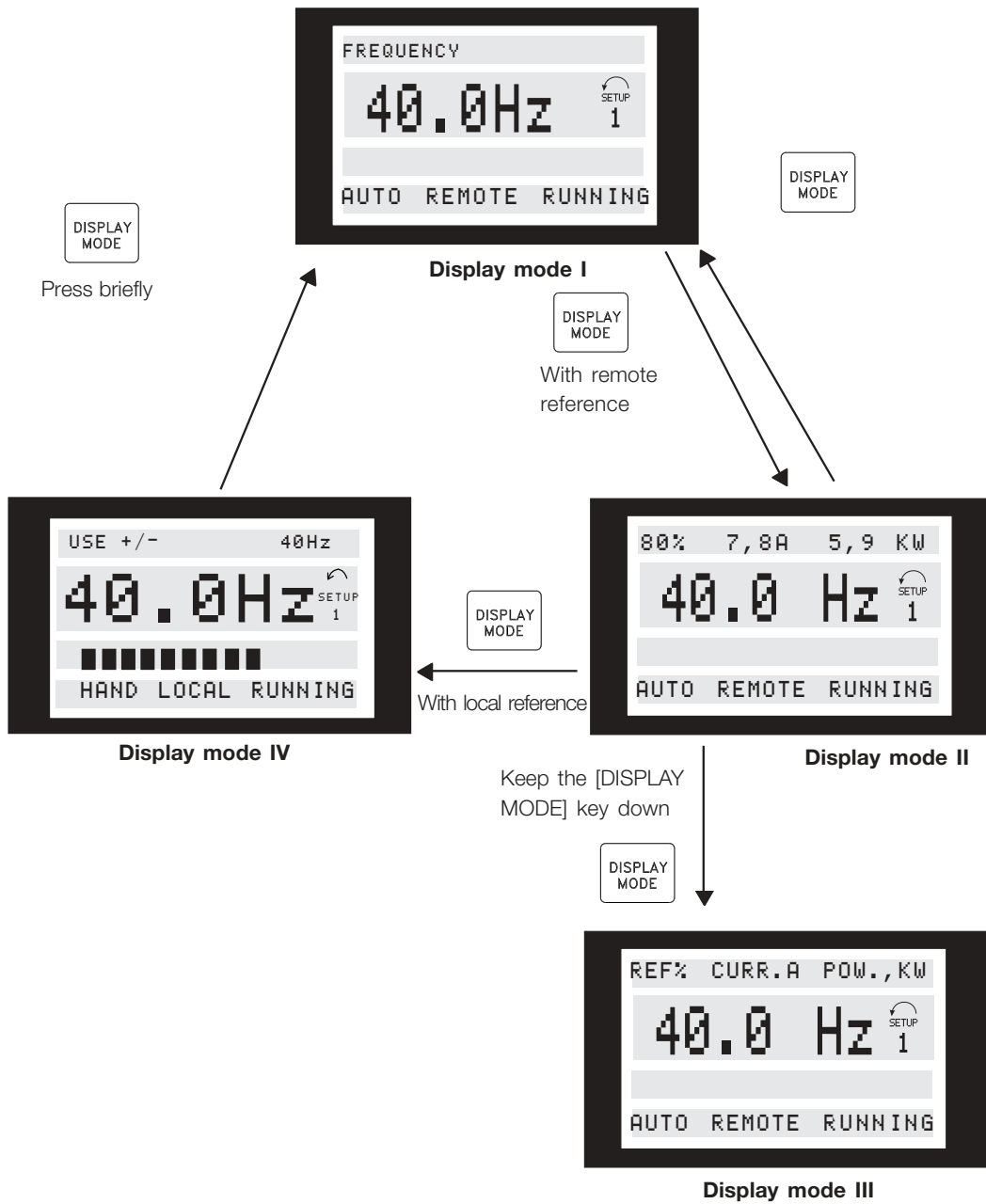

175ZA697.10

■ Changing data

Regardless of whether a parameter has been selected under the Quick menu or the Extended menu, the procedure for changing data is the same. Pressing the [CHANGE DATA] key allows change of the selected parameter, and the underlining in line 4 will flash on the display.

The procedure for changing data depends on whether the selected parameter represents a numerical data value or a functional value.

If the chosen parameter represents a numeric data value, the first digit can be changed by means of the [+/-] keys. If the second digit is to be changed, first move the cursor by using the [<>] keys, then change the data value using the [+/-] keys.

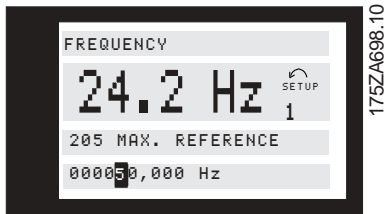

The selected digit is indicated by a flashing cursor. The bottom display line gives the data value that will be entered (saved) when signing off by pressing the [OK] button. Use [CANCEL] to cancel the change.

If the selected parameter is a functional value, the selected text value can be changed by means of the [+/-] keys.

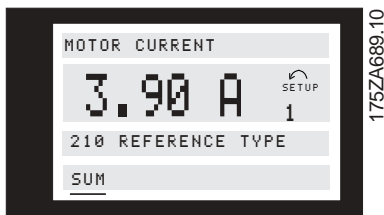

The functional value flashes until signing off by pressing the [OK] button. The functional value has now been selected. Use [CANCEL] to cancel the change.

■ Infinitely variable change of numeric data value

If the chosen parameter represents a numeric data value, a digit is first selected by means of the [<>] keys.

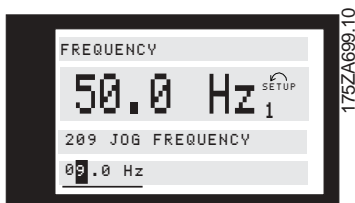

Then the chosen digit is changed infinitely by means of the [+/-] keys:

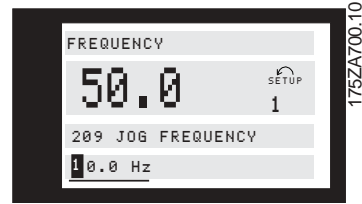

The chosen digit flashes. The bottom display line shows the data value that will be entered (saved) when signing off with [OK].

■ Changing of data value, step-by-step

Certain parameters can be changed both step by step and infinitely variably. This applies to *Motor power* (parameter 102), *Motor voltage* (parameter 103) and *Motor frequency* (parameter 104).

This means that the parameters are changed both as a group of numeric data values and as numeric data values infinitely variably.

■ Manual initialisation

Disconnect from mains and hold the [DISPLAY MODE] + [CHANGE DATA] + [OK] keys down while at the same time reconnecting the mains supply. Release the keys; the frequency converter has now been programmed for the factory setting.

The following parameters are not zeroed by means of manual initialisation:

Parameter	500, <i>Protocol</i>
	600, <i>Operating hours</i>
	601, <i>hours run</i>
	602, <i>kWh counter</i>
	603, <i>Number of power-ups</i>
	604, <i>Number of overtemperatures</i>
	605, <i>Number of overvoltages</i>

It is also possible to carry out initialisation via parameter 620 *Operating mode*.

■ Quick Menu

The QUICK MENU key gives access to 12 of the most important setup parameters of the drive. After programming, the drive will, in many cases, be ready for operation. The 12 Quick Menu parameters are

shown in the table below. A complete description of the function is given in the parameter sections of this manual.

Quick Menu Item Number	Parameter Name	Description
1	001 Language	Selects language used for all displays.
2	102 Motor Power	Sets output characteristics of drive based on kW size of motor.
3	103 Motor Voltage	Sets output characteristics of drive based on voltage of motor.
4	104 Motor Frequency	Sets output characteristics of drive based on nominal frequency of motor. This is typically equal to line frequency.
5	105 Motor Current	Sets output characteristics of drive based on nominal current in amps of motor.
6	106 Motor Nominal Speed	Sets output characteristics of drive based on nominal full load speed of motor.
7	201 Minimum Frequency	Sets minimum controlled frequency at which motor will run.
8	202 Maximum Frequency	Sets maximum controlled frequency at which motor will run.
9	206 Ramp Up Time	Sets time to accelerate motor from 0 Hz to nominal motor frequency set in Quick Menu Item 4.
10	207 Ramp Down Time	Sets time to decelerate motor from nominal motor frequency set in Quick Menu Item 4 to 0 Hz.
11	323 Relay1 Function	Sets function of high voltage Form C relay.
12	326 Relay 2 Function	Sets function of low voltage Form A relay.

■ Parameter Data

Enter or change parameter data or settings in accordance with the following procedure.

1. Press Quick Menu key.
2. Use '+' and '-' keys to find parameter you choose to edit.
3. Press Change Data key.
4. Use '+' and '-' keys to select correct parameter setting. To move to a different digit within parameter, use < and > arrows. *Flashing cursor indicates digit selected to change.*
5. Press Cancel key to disregard change, or press OK key to accept change and enter new setting.
3. Press Change Data key.
4. Press < key twice – hundreds digit will flash.
5. Press '+' key once to change hundreds digit to '1.'
6. Press > key to change to tens digit.
7. Press '-' key until '6' counts down to '0' and setting for *Ramp Up Time* reads '100 s.'
8. Press OK key to enter new value into drive controller.

Example of Changing Parameter Data

Assume parameter 206, *Ramp Up Time*, is set at 60 seconds. Change the ramp up time to 100 seconds in accordance with the following procedure.

1. Press Quick Menu key.
2. Press '+' key until you reach Parameter 206, *Ramp Up Time*.

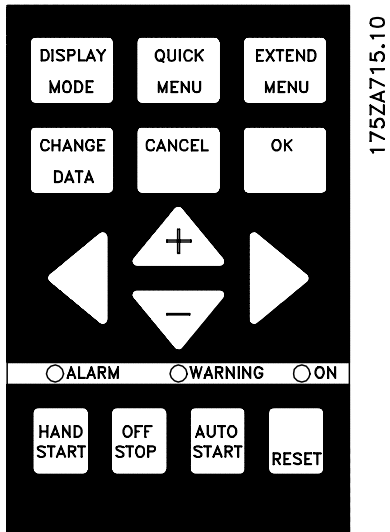

NB!:

Programming of extended parameters functions available through EXTENDED MENU key is done in accordance with same procedure as described for Quick Menu functions.

■ Programming

EXTEND
MENU

Using the [EXTEND MENU] key, it is possible to have access to all the parameters for the frequency converter.

■ Operation and Display 001-017

This parameter group allows to set up parameters such as language, display readout and the possibility of making the function keys on the control unit inactive.

001 Language

(LANGUAGE)

Value:

★English (ENGLISH)	[0]
German (DEUTSCH)	[1]
French (FRANCAIS)	[2]
Danish (DANSK)	[3]
Spanish (ESPAÑOL)	[4]
Italian (ITALIANO)	[5]
Swedish (SVENSKA)	[6]
Dutch (NEDERLANDS)	[7]
Portuguese (PORTUGUESA)	[8]
Finnish (SUOMI)	[9]

State when delivered may vary from factory setting.

Function:

The choice in this parameter defines the language to be used on the display.

Description of choice:

There is a choice of the languages indicated.

■ The Setup configuration

The frequency converter has four Setups (parameter Setups) that can be programmed independently of each other. The active Setup can be selected in parameter 002 *Active Setup*. The active Setup number will be shown in the display under "Setup". It is also possible to set the frequency converter to Multi-Setup to allow switching of Setups with the digital inputs or serial communication.

Setup shifts can be used in systems where, one Setup is used during the day and another at night.

Parameter 003 *Copying of Setups* enables copying from one Setup to another.

★ = factory setting. () = display text [] = value for use in communication via serial communication port

By means of parameter 004 *LCP copy*, all Setups can be transferred from one frequency converter to another by moving the control panel. First all parameter values are copied to the control panel. This can then be moved to another frequency converter, where all parameter values can be copied from the control unit to the frequency converter.

002 Active Setup

(ACTIVE SETUP)

Value:

Factory Setup (FACTORY SETUP)	[0]
★Setup 1 (SETUP 1)	[1]
Setup 2 (SETUP 2)	[2]
Setup 3 (SETUP 3)	[3]
Setup 4 (SETUP 4)	[4]
MultiSetup (MULTI SETUP)	[5]

Function:

The choice in this parameter defines the Setup number you want to control the functions of the frequency converter. All parameters can be programmed in four individual parameter Setups, Setup 1 - Setup 4. In addition, a pre-programmed Setup called the Factory Setup exists. This only allows specific parameters to be changed.

Description of choice:

Factory Setup [0] contains the parameter values pre-set at the factory. Can be used as a data source if the other Setups are to be returned to a common state. In this case Factory Setup is selected as the active Setup. *Setups 1-4* [1]-[4] are four individual Setups that can be selected as required.

MultiSetup [5] is used if remote switching between different Setups is required. Terminals 16/17/29/32/33 and the serial communication port can be used for switching between Setups.

Connection examples Setup change

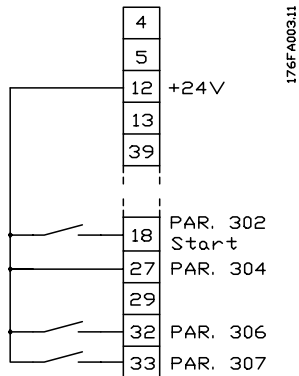

- Selection of Setup using terminals 32 and 33.
Parameter 306 = Selection of Setup, lsb [4]
Parameter 307 = Selection of Setup, msb [4]
Parameter 002 = MultiSetup [5].

- (UPLOAD ALL PARAMET.) [1]
Download all parameters
- (DOWNLOAD ALL PARAM.) [2]
Download power-independent par.
- (DOWNLOAD SIZE INDEP.) [3]

Function:

Parameter 004 *LCP copy* is used if the integrated copying function of the control panel is to be used. This function is used if all parameter Setups are to be copied from one frequency converter to another by moving the control panel.

Description of choice:

Select *Upload all parameters* [1] if all parameter values are to be transmitted to the control panel.
Select *Download all parameters* [2] if all transmitted parameter values are to be copied to the frequency converter on which the control panel has been mounted.
Select *Download power-independent par.* [3] if only the power-independent parameters are to be downloaded. This is used if downloading to a frequency converter that has a different rated power than the one from where the parameter Setup originates.



NB!:

Uploading/Downloading can only be carried out in the Stop mode.

003 Copying of Setups (SETUP COPY)

Value:	
★No copying (NO COPY)	[0]
Copy active Setup to Setup 1 (COPY TO SETUP 1)	[1]
Copy active Setup to Setup 2 (COPY TO SETUP 2)	[2]
Copy active Setup to Setup 3 (COPY TO SETUP 3)	[3]
Copy active Setup to Setup 4 (COPY TO SETUP 4)	[4]
Copy active Setup to all (COPY TO ALL)	[5]

Function:
A copy is made from the active Setup selected in parameter 002 *Active Setup* to the Setup or Setups selected in parameter 003 *Copying of Setups*.

NB!:
Copying is only possible in Stop mode (motor stopped on a Stop command).

Description of choice:
The copying starts when the required copying function has been selected and the [OK] key has been pressed. The display indicates when copying is in progress.

004 LCP copy (LCP COPY)

Value:	
★No copying (NO COPY)	[0]

- Upload all parameters
- ★ = factory setting. () = display text [] = value for use in communication via serial communication port

■ Setup of user-defined readout

Parameter 005 *Max. value of user-defined readout* and 006 *Unit for user-defined readout* allow users to design their own readout which can be seen if user-defined readout has been selected under display readout. The range is set in parameter 005 *Max. value of user-defined readout* and the unit is determined in parameter 006 *Unit for user-defined readout*. The choice of unit decides whether the ratio between the output frequency and the readout is a linear, square or cubed ratio.

005 Max. value of user-defined readout (CUSTOM READOUT)

Value:

0.01 - 999,999.99 ★ 100.00

Function:

This parameter allows a choice of the max. value of the user-defined readout. The value is calculated on the basis of the present motor frequency and the unit selected in parameter 006 *Unit for user-defined readout*. The programmed value is reached when the output frequency in parameter 202 *Output frequency high limit*, f_{MAX} is reached. The unit also decides whether the ratio between output frequency and readout is linear, square or cubed.

Description of choice:

Set the required value for max. output frequency.

006 Unit for user-defined readout (CUST. READ. UNIT)

★No unit ¹	[0]	GPM ¹	[21]
% ¹	[1]	gal/s ¹	[22]
rpm ¹	[2]	gal/min ¹	[23]
ppm ¹	[3]	gal/h ¹	[24]
pulse/s ¹	[4]	lb/s ¹	[25]
l/s ¹	[5]	lb/min ¹	[26]
l/min ¹	[6]	lb/h ¹	[27]
l/h ¹	[7]	CFM ¹	[28]
kg/s ¹	[8]	ft ³ /s ¹	[29]
kg/min ¹	[9]	ft ³ /min ¹	[30]
kg/h ¹	[10]	ft ³ /h ¹	[31]
m ³ /s ¹	[11]	ft ³ /min ¹	[32]
m ³ /min ¹	[12]	ft/s ¹	[33]
m ³ /h ¹	[13]	in wg ²	[34]
m/s ¹	[14]	ft wg ²	[35]
mbar ²	[15]	PSI ²	[36]
bar ²	[16]	lb/in ²	[37]
Pa ²	[17]	HP ³	[38]
kPa ²	[18]		
MWG ²	[19]		
kW ³	[20]		

Flow and speed units are marked with 1.
Pressure units with 2, and power units with 3. See figure in next column.

Function:

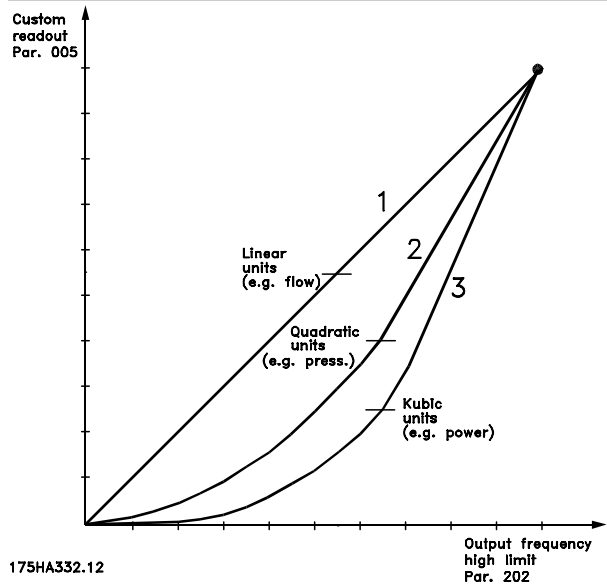

175HA332.12

Select a unit to be shown in the display in connection with parameter 005 *Max. value of user-defined readout*. If units such as flow or speed units are selected, the ratio between readout and output frequency will be a linear one.

If pressure units are selected (bar, Pa, MWG, PSI, etc.), the ratio will be square. If power units (HP, kW) are selected, the ratio will be cubed.

The value and the unit are shown in display mode whenever *User-defined readout* [10] has been selected in one of parameters 007-010 *Display readout*.

Description of choice:

Select the required unit for *User-defined readout*.

007 Large display readout

(LARGE READOUT)

Value:

Resulting reference [%] (REFERENCE [%])	[1]
Resulting reference [unit] (REFERENCE [UNIT])	[2]
★Frequency [Hz] (FREQUENCY [HZ])	[3]
% of maximum output frequency [%] (FREQUENCY [%])	[4]
Motor current [A] (MOTOR CURRENT [A])	[5]
Power [kW] (POWER [KW])	[6]
Power [HP] (POWER [HP])	[7]
Output energy [kWh] (ENERGI [UNIT])	[8]
Hours run [Hours] (OURS RUN [H])	[9]
User-defined readout [-] (CUSTOM READ.[UNITS])	[10]
Setpoint 1 [unit] (SETPOINT 1 [UNITS])	[11]
Setpoint 2 [unit] (SETPOINT 2 [UNITS])	[12]
Feedback 1 (FEEDBACK 1 [UNITS])	[13]
Feedback 2 (FEEDBACK 2 [UNITS])	[14]

★ = factory setting. () = display text [] = value for use in communication via serial communication port

Feedback [unit] (FEEDBACK [UNITS])	[15]
Motor voltage [V] (MOTOR VOLTAGE [V])	[16]
DC link voltage [V] (DC VOLTAGE [V])	[17]
Thermal load, motor [%] (THERM.MOTOR LOAD [%])	[18]
Thermal load, VLT [%] (THERM.DRIVE LOAD [%])	[19]
Digital input [Binary code] (DIGITAL INPUT [BIN])	[20]
Analogue input 53 [V] (ANALOG INPUT 53 [V])	[21]
Analogue input 54 [V] (ANALOG INPUT 54 [V])	[22]
Analogue input 60 [mA] (ANALOG INPUT 60 [MA])	[23]
Relay status [binary code] (RELAY STATUS)	[24]
Pulse reference [Hz] (PULSE REFERENCE [HZ])	[25]
External reference [%] (EXT. REFERENCE [%])	[26]
Heat sink temp. [°C] (HEATSINK TEMP [°C])	[27]
Communication option card warning (COMM OPT WARN [HEX])	[28]
LCP display text (FREE PROG.ARRAY)	[29]
Status word (STATUS WORD [HEX])	[30]
Control word (CONTROL WORD [HEX])	[31]
Alarm word (ALARM WORD [HEX])	[32]
PID output [Hz] (PID OUTPUT [HZ])	[33]
PID output [%] (PID OUTPUT [%])	[34]

Function:

This parameter allows a choice of the data value to be shown in the display, line 2, when the frequency converter is turned on. The data values will also be included in the display mode scroll-list. Parameters 008-010 *Small display readout* allow a choice of another three data values, shown in line 1. See the description of the *control unit*.

Description of choice:

No readout can only be selected in parameters 008-010 *Small display readout*.

Resulting reference [%] gives a percentage for the resulting reference in the range from *Minimum reference*, Ref_{MIN} to *Maximum reference*, Ref_{MAX}. See also *reference handling*.

Reference [unit] gives the resulting reference in Hz in *Open loop*. In *Closed loop*, the reference unit is selected in parameter 415 *Process units*.

Frequency [Hz] gives the output frequency from the frequency converter.

% of maximum output frequency [%] is the present output frequency as a percentage value of parameter 202 *Output frequency high limit*, f_{MAX} .

Motor current [A] states the phase current of the motor measured as effective value.

Power [kW] states the actual power consumed by the motor in kW.

Power [HP] states the actual power consumed by the motor in HP.

Output energy [kWh] states the energy consumed by the motor since the latest reset was made in parameter 618 *Reset of kWh counter*.

Hours run [Hours] states the number of hours that the motor has run since the latest reset in parameter 619 *Reset of hours-run counter*.

User -defined readout [-] is a user-defined value, calculated on the basis of the present output frequency and unit, as well as the scaling in parameter 005 *Max. value of user-defined readout*. Select unit in parameter 006 *Unit for user-defined readout*.

Setpoint 1 [unit] is the programmed setpoint value in parameter 418 *Setpoint 1*. The unit is decided in parameter 415 *Process units*. See also *Feedback handling*.

Setpoint 2 [unit] is the programmed setpoint value in parameter 419 *Setpoint 2*. The unit is decided in parameter 415 *Process units*.

Feedback 1 [unit] gives the signal value of the resulting feedback 1 (Term. 53). The unit is decided in parameter 415 *Process units*. See also *Feedback handling*.

Feedback 2 [unit] gives the signal value of the resulting feedback 2 (Term. 53). The unit is decided in parameter 415 *Process units*.

Feedback [unit] gives the resulting signal value using the unit/scaling selected in parameter 413 *Minimum feedback*, FB_{MIN}, 414 *Maximum feedback*, FB_{MAX} and 415 *Process units*.

Motor voltage [V] states the voltage supplied to the motor.

DC link voltage [V] states the intermediate circuit voltage in the frequency converter.

Thermal load, motor [%] states the calculated/estimated thermal load on the motor. 100% is the cut-out limit. See also parameter 117 *Motor thermal protection*.

Thermal load, VLT [%] states the calculated/estimated thermal load on the frequency converter. 100% is the cut-out limit.

Digital input [Binary code] states the signal status from the 8 digital inputs (16, 17, 18, 19, 27, 29, 32 and 33). Terminal 16 corresponds to the bit at the far left. '0' = no signal, '1' = connected signal.

Analogue input 53 [V] states the voltage value on terminal 53.

Analogue input 54 [V] states the voltage value on terminal 54.

Analogue input 60 [mA] states the voltage value on terminal 60.

Relay status [binary code] indicates the status of each relay. The left (most significant) bit indicates relay

★ = factory setting. () = display text [] = value for use in communication via serial communication port

1 followed by 2 and 6 through 9. A "1" indicates the relay is active, a "0" indicates inactive. Parameter 007 uses an 8-bit word with the last two positions not used. Relays 6-9 are provided with the cascade controller and four relay option cards

Pulse reference [Hz] states a pulse frequency in Hz connected to terminal 17 or terminal 29.

External reference [%] gives the sum of the external references as a percentage (the sum of analogue/pulse/serial communication) in the range from *Minimum reference*, Ref_{MIN} to *Maximum reference*, Ref_{MAX}.

Heat sink temp. [°C] states the present heat sink temperature of the frequency converter. The cut-out limit is 90 ± 5°C; cutting back in occurs at 60 ± 5°C.

Communication option card warning [Hex] gives a warning word if there is a fault on the communication bus. This is only active if communication options have been installed. Without communication options, 0 Hex is displayed.

LCP display text shows the text programmed in parameter 533 *Display text 1* and 534 *Display text 2* via LCP or the serial communication port.

LCP procedure for entering text

After selecting *Display Text* in parameter 007, select display line parameter (533 or 534) and press the **CHANGE DATA** key. Enter text directly into the selected line by using **UP, DN & LEFT, RIGHT** arrow keys on the LCP. The UP and DN arrow keys scroll through the available characters. The Left and Right arrow keys move the cursor through the line of text. To lock in the text, press the **OK** key when the line of text is completed. The **CANCEL** key will cancel the text.

The available characters are:

A B C D E F G H I J K L M N O P Q R S T U V W X Y Z

Æ Ø Å Ä Ö Ü È Ì Ù è . / - () 0 1 2 3 4 5 6 7 8 9 'space'

'space' is the default value of parameter 533 &

534. To erase a character that has been entered, it must be replaced with 'space'.

Status word displays the actual drive status word (see parameter 608).

Control word displays the actual control word (see parameter 607).

Alarm word displays the actual alarm word.

PID output shows the calculated PID output in the display in either Hz [33] or percentage of max frequency [34].

008 Small display readout 1.1

(SMALL READOUT 1)

Value:

See parameter 007 *Large display readout*

★ Reference [Unit] [2]

Function:

This parameter enables a choice of the first of three data values to be shown on the display, line 1, position 1.

This is a useful function, i.a. when setting the PID regulator, in order to see how the process reacts to a change of reference.

For display read-outs, press the [DISPLAY MODE] button. Data option *LCP display text* [29] cannot be selected with *Small display readout* .

Description of choice:

There is a choice of 33 different data values, see parameter 007 *Large display readout*.

★ = factory setting. () = display text [] = value for use in communication via serial communication port

009 Small display readout 1.2

(SMALL READOUT 2)

Value:

See parameter 007 *Large display readout*

★Motorcurrent [A] [5]

Function:

See the functional description for parameter 008 *Small display readout*. Data option *LCP display text* [29] cannot be selected with *Small display readout*.

Description of choice:

There is a choice of 33 different data values, see parameter 007 *Large display readout*.

010 Small display readout 1.3

(SMALL READOUT 3)

Value:

See parameter 007 *Large display readout*

★Power [kW] [6]

Function:

See the functional description for parameter 008 *Small data readout*. Data option *LCP display text* [29] cannot be selected with *Small display readout*.

Description of choice:

There is a choice of 33 different data values, see parameter 007 *Large display readout*.

011 Unit of local reference

(UNIT OF LOC REF)

Value:

Hz (HZ) [0]

★% of output frequency range (%) (% OF FMAX) [1]

Function:

This parameter decides the local reference unit.

Description of choice:

Choose the required unit for local reference.

012 Hand start on LCP

(HAND START BTTN)

Value:

Disable (DISABLE) [0]

★Enable (ENABLE) [1]

Function:

This parameter allows selection/deselection of the Hand start key on the control panel.

Description of choice:

If *Disable* [0] is selected in this parameter, the [HAND START] key will be inactive.

013 OFF/STOP on LCP

(STOP BUTTON)

Value:

Disable (DISABLE) [0]

★Enable (ENABLE) [1]

Function:

This parameter allows selection/deselection of the local stop key on the control panel.

Description of choice:

If *Disable* [0] is selected in this parameter, the [OFF/ STOP] key will be inactive.



NB!:

If *Disable* is selected, the motor cannot be stopped by means of the [OFF/STOP] key.

014 Auto start on LCP

(AUTO START BTTN)

Value:

Disable (DISABLE) [0]

★Enable (ENABLE) [1]

Function:

This parameter allows selection/deselection of the auto start key on the control panel.

Description of choice:

If *Disable* [0] is selected in this parameter, the [AUTO START] key will be inactive.

015 Reset on LCP

(RESET BUTTON)

Value:

Disable (DISABLE) [0]

★Enable (ENABLE) [1]

Function:

This parameter allows selection/deselection of the reset key on the control panel.

★ = factory setting. () = display text [] = value for use in communication via serial communication port

Description of choice:

If *Disable* [0] is selected in this parameter, the [RESET] key will be inactive.



NB!:

Only select *Disable* [0] if an external reset signal has been connected via the digital inputs.



NB!:

If [HAND START] or [AUTO START] cannot be activated by the keys on the control panel (see parameter 012/014 *Hand/Auto start on LCP*) the motor will not be able to restart if *OFF/Stop* [1] is selected. If Handstart or Autostart has been programmed for activation via the digital inputs, the motor will not be able to restart if *OFF/Stop* [1] is selected.

016 Lock for data change

(DATA CHANGE LOCK)

Value:

★Not locked (NOT LOCKED)	[0]
Locked (LOCKED)	[1]

Function:

This parameter allows the control panel to be "locked", which means that it is not possible to carry out data modifications via the control unit.

Description of choice:

If *Locked* [1] is selected, data modifications in the parameters cannot be made, although it will still be possible to carry out data modifications via the bus. Parameters 007-010 *Display readout* can be changed via the control panel.

It is also possible to lock for data modifications in these parameters by means of a digital input, see parameters 300-307 *Digital inputs*.

017 Operating state at power up, local control

(POWER UP ACTION)

Value:

★Auto restart (AUTO RESTART)	[0]
OFF/Stop (OFF/STOP)	[1]

Function:

Setting of the desired operating mode when the mains voltage is reconnected.

Description of choice:

Auto restart [0] is selected if the frequency converter is to start up in the same start/stop condition as immediately before power to the frequency converter is cut off. *OFF/Stop* [1] is selected if the frequency converter is to remain stopped when the mains voltage is connected, until a start command is active. To restart, activate the key [HAND START] or [AUTO START] by using the control panel.

★ = factory setting. () = display text [] = value for use in communication via serial communication port

■ **Load and motor 100-124**

This parameter group allows the configuration of regulation parameters and the choice of torque characteristics to which the frequency converter is to be adapted.

The motor nameplate data must be set and automatic motor adaptation can be carried out. In addition, DC brake parameters can be set and the motor thermal protection can be activated.

■ **Configuration**

The selection of configuration and torque characteristics influences the parameters that can be seen in the display. If *Open loop* [0] is selected, all parameters relating to PID regulation will be hidden.

Consequently, the user is only able to see the parameters that are of significance for a given application.

100 Configuration
(CONFIG. MODE)

Value:

★Open loop (OPEN LOOP)	[0]
Closed loop (CLOSED LOOP)	[1]

Function:
This parameter is used for selecting the configuration to which the frequency converter is to be adapted.

Description of choice:
If *Open loop* [0] is selected, normal speed control is obtained (without feedback signal), i.e. if the reference is changed, the motor speed will change.
If *Closed loop* [1] is selected, the internal process regulator is activated to enable accurate regulation in relation to a given process signal.
The reference (setpoint) and the process signal (feedback) can be set to a process unit as programmed in parameter 415 *Process units*. See *Feedback handling*.

101 Torque characteristics
(VT CHARACT)

Value:

★Automatic Energy Optimization (AEO FUNCTION)	[0]
Constant Torque (CONSTANT TORQUE)	[1]
Variable Torque Low (VT LOW)	[2]
Variable Torque Medium (VT MED)	[3]
Variable Torque High (VT HIGH)	[4]

Function:
This parameter allows a choice of whether the frequency converter operates with the controller adjusting the U/f curve automatically in response to the load, or whether variable or constant torque operation is selected.

Description of choice:
For variable torque loads such as centrifugal pumps and fans, the drive provides two operational modes. Automatic Energy Optimization enables the controller to dynamically adjust the U/f ratio in response to the motor load or speed changes to maximize motor and drive efficiency while reducing motor heat and noise. Parameter 118 makes it possible to set the power factor (Cos φ) which is used by the AEO function.

The Variable Torque option provides low, medium and high levels of voltage as shown in the figure below (as a percentage of nominal motor voltage.) VT may be used with more than one motor connected to the output in parallel. Select the torque characteristic with the most reliable operation and the least energy consumption, motor heat and noise. The starting voltage can be selected in parameter 108, *VT Start Voltage*.

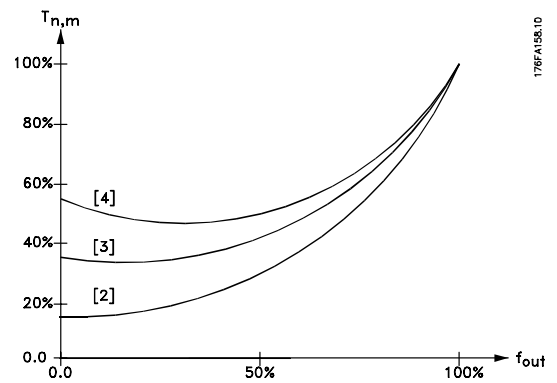

For constant torque loads such as conveyor belts, presses, mixers, screws and so forth, select *Constant Torque*. CT operation is achieved by maintaining a constant U/f ratio over the operating range.

Programming

★ = factory setting. () = display text [] = value for use in communication via serial communication port



NB!:

It is important that the values set in parameters 102-106 Nameplate data correspond to the nameplate data of the motor with respect to either star coupling Y or delta coupling Δ .

102 Motor power, $P_{M,N,M,N}$

(MOTOR POWER)

Value:

0.25 HP (0.25 KW)	[25]
0.5 HP (0.37 KW)	[37]
0.75 HP (0.55 KW)	[55]
1 HP (0.75 KW)	[75]
1.5 HP (1.10 KW)	[110]
2 HP (1.50 KW)	[150]
3 HP (2.20 KW)	[220]
4 HP (3.00 KW)	[300]
5 HP (4.00 KW)	[400]
7.5 HP (5.50 KW)	[550]
10 HP (7.50 KW)	[750]
15 HP (11.00 KW)	[1100]
20 HP (15.00 KW)	[1500]
25 HP (18.50 KW)	[1850]
30 HP (22.00 KW)	[2200]
40 HP (30.00 KW)	[3000]
50 HP (37.00 KW)	[3700]
60 HP (45.00 KW)	[4500]
75 HP (55.00 KW)	[5500]
100 HP (75.00 KW)	[7500]
125 HP (90.00 KW)	[9000]
150 HP (110.00 KW)	[11000]
200 HP (132.00 KW)	[13200]
250 HP (160.00 KW)	[16000]
300 HP (200.00 KW)	[20000]
350 HP (250.00 KW)	[25000]
400 HP (300.00 KW)	[30000]
450 HP (315.00 KW)	[31500]
500 HP (355.00 KW)	[35500]
600 HP (400.00 KW)	[40000]

★Depends on the unit

Function:

This is where to select the kW value $P_{M,N}$ that corresponds to the rated power of the motor. At the works, a rated kW value $P_{M,N}$ has been selected that depends on the type of unit.

Description of choice:

Select a value that equals the nameplate data on the motor. There are 4 possible undersizes or 1 oversize in comparison with the factory setting.

Also, alternatively it is possible to set the value of the motor power infinitely variable value, see the procedure for infinitely variable change of numeric data value.

103 Motor voltage, $U_{M,N}$

(MOTOR VOLTAGE)

Value:

200 V	[200]
208 V	[208]
220 V	[220]
230 V	[230]
240 V	[240]
380 V	[380]
400 V	[400]
415 V	[415]
440 V	[440]
460 V	[460]
480 V	[480]
500 V	[500]
550 V	[550]
575 V	[575]
690 V	[690]

★Depends on the unit

Function:

This is where the rated motor voltage $U_{M,N}$ is set for either star Y or delta Δ .

Description of choice:

Select a value that equals the nameplate data on the motor, regardless of the mains voltage of the frequency converter. Furthermore, alternatively it is possible to set the value of the motor voltage infinitely variably. Also refer to the procedure for infinitely variable change of numeric data value.

104 Motor frequency, $f_{M,N}$

(MOTOR FREQUENCY)

Value:

- ▼ 50 Hz (50 HZ) [50]
- ★60 Hz (60 HZ) [60]

▼) Global factory setting different from North American factory setting.

Function:

Select the rated motor frequency $f_{M,N}$.

Description of choice:

Select a value that equals the nameplate data on the motor.

105 Motor current, $I_{M,N}$

(MOTOR CURRENT)

Value:

0.01 - $I_{VLT,MAX}$ A

★ Depends on the choice of motor.

Function:

The rated motor current $I_{M,N}$ forms part of the frequency converter calculations of torque and motor thermal protection. Set the motor current $I_{VLT,N}$, taking into account the star Y or delta Δ connected motor.

Description of choice:

Set a value that equals the nameplate data on the motor.



NB!:

It is important to enter the correct value, since this forms part of the V V C PLUS control feature.

106 Rated motor speed, $n_{M,N}$

(MOTOR NOM. SPEED)

Value:

100 - $f_{M,N} \times 60$ (max. 60000 rpm)

★ Depends on parameter 102 *Motor power*, $P_{M,N}$.

Function:

This sets the value that corresponds to the rated motor speed $n_{M,N}$, from the nameplate data.

Description of choice:

Choose a value that corresponds to the motor nameplate data.



NB!:

It is important to set the correct value, since this forms part of the V V C PLUS control feature.

The max. value equals $f_{M,N} \times 60$. $f_{M,N}$ is set in parameter 104 *Motor frequency*, $f_{M,N}$.

107 Automatic motor adaptation, AMA

(AUTO MOTOR ADAPT)

Value:

- ★Optimization disable (NO AMA) [0]
- Automatic adaptation (RUN AMA) [1]
- Limited AMA (RUN LIMITED AMA) [2]

Function:

Automatic motor adaptation is a test algorithm that measures the electrical motor parameters at motor standstill. This means that AMA itself does not supply any torque.

AMA is useful when commissioning systems, where the user wants to optimise the adjustment of the frequency converter to the motor applied. This feature is used where the factory setting does not match requirements of the motor.

For the best adjustment of the frequency converter, it is recommended to carry out AMA on a cold motor. It must be noted that repeated AMA runs may lead to a heating of the motor that will result in an increase of the stator resistance R_s . However, this is not normally critical.

It is possible via parameter 107 *Automatic motor adaptation*, AMA to choose whether a complete automatic motor adaptation *Automatic adaptation* [1] is to be carried out, or whether reduced automatic motor adaptation *Limited AMA* [2] is to be made. It is possible to carry out the reduced test if a LC-filter has been placed between the frequency converter and the motor. If a total setting is required, the LC-filter can be removed and, after completion of the AMA, it can be reinstalled. In *Limited AMA* [2] there is no test of motor symmetry and of whether all motor phases have been connected. The following must be noted when the AMA function is used:

- For AMA to be able to determine the motor parameters optimally, the correct nameplate data for the motor connected to the frequency converter must be entered in parameters 102 to 106.
- The duration of a total automatic motor adaptation varies from a few minutes to approx. 10 minutes for small motors, depending on the rating of

the motor used (the time for a 7.5 HP motor, for example, is approx. 4 minutes).

- Alarms and warnings will be shown in the display if faults occur during motor adaptation.
- AMA can only be carried out if the rated motor current of the motor is min. 35% of the rated out-put current of the frequency converter.



NB!

Some motors (such as motors with 6 or more poles) may be unable to run Automatic Adaptation. Limited AMA or use of parameters 123 and 124 is a procedure which can be effective in such cases since procedure measures motor's stator and effects of cable length. Multiple motor applications cannot use any form of AMA.

Description of choice:

Select *Automatic adaptation* [1] if the frequency converter is to carry out a complete automatic motor adaptation. Select *Limited AMA* [2] if an LC-filter has been placed between the frequency converter and the motor, or for six or more pole motors.

Procedure for automatic motor adaptation:

1. Set the motor parameters in accordance with the motor nameplate data given in parameters 102-106 *Nameplate data*.
2. Connect 24 V DC (possibly from terminal 12) to terminal 27 on the control card.
3. Select Automatic adaptation [1] or Limited AMA [2] in parameter 107 *Automatic motor adaptation*, AMA.
4. Start up the frequency converter or connect terminal 18 (start) to 24 V DC (possibly from terminal 12).

If the automatic motor adaptation is to be stopped:

1. Press the [OFF/STOP] key.

After a normal sequence, the display reads: AMA STOP

1. The frequency converter is now ready for operation.



NB!

[RESET] key must be pressed after AMA is completed to save results into drive.

If there is a fault, the display reads: ALARM 22

1. Check for possible causes of the fault in accordance with the alarm message. See *list of warnings and alarms*.
2. Press the [RESET] key to clear fault.

If there is a warning, the display reads: WARNING 39-42

1. Check for possible causes of the fault in accordance with the warning. See *list of warnings and alarms*.
2. Press the [CHANGE DATA] key and select "Continue" if AMA is to continue despite the warning, or press the [OFF/STOP] key to stop the automatic motor adaptation.

108 Variable Torque Starting Voltage (VT START VOLT)

Value:

0.0 - parameter 103 *Motor voltage*, $U_{M,N}$

★ depends on par. 103 *Motor voltage*, $U_{M,N}$

Function:

This parameter specifies the start-up voltage for VT characteristics at 0 Hz. It is also used for motors connected in parallel.

The start-up voltage represents a supplementary voltage input to the motor. By increasing the start-up voltage, motors receive a higher start-up torque. This is used especially for small motors (< 4.0 kW/5 HP) connected in parallel, as they have a higher stator resistance than motors above 5.5 kW/7.5 HP. This function is only active if *Variable torque* [1], [2] or [3] has been selected in parameter 101 *Torque characteristics*.

Description of choice:

Set the start-up voltage at 0 Hz. The maximum voltage depends on parameter 103 *Motor voltage*, $U_{M,N}$.

109 Resonance damping (RESONANCE DAMP.)

Value:

0 - 500 %

★ 100 %

Function:

High-frequency electric resonance problems between the frequency converter and the motor can be eliminated by adjusting the resonance damping.

Description of choice:

Adjust the damping percentage until the motor resonance has disappeared.

**110 High break-away torque
(HIGH START TORQ.)**

Value:

0.0 - 0.5 sec. ★ 0.0 sec.

Function:

In order to secure a high starting torque, the maximum torque for max. 0.5 sec. is allowed. However, the current is limited by the protection limit of the frequency converter. 0 sec. corresponds to no high break-away torque.

Description of choice:

Set the necessary time in which a high starting torque is desired.

111 Start delay

(START DELAY)

Value:

0.0 - 120.0 sec. ★ 0.0 sec.

Function:

This parameter enables a delay of the starting time after the conditions for start have been fulfilled. When the time has passed, the output frequency will start by ramping up to the reference.

Description of choice:

Set the desired time until acceleration is to begin.

112 Motor preheater

(MOTOR PREHEAT)

Value:

★Disable (DISABLE) [0]
Enable (ENABLE) [1]

Function:

The motor preheater ensures that no condensate develops in the motor at stop. This function can also be used to evaporate condensed water in the motor. The motor preheater is only active during stop.

Description of choice:

Select *Disable* [0] if this function is not required. Select *Enable* [1] to activate motor preheating. The DC current is set in parameter 113 *Motor preheater DC current*.

**113 Motor preheater DC current
(PREHEAT DC-CURR.)**

Value:

0 - 100 % ★ 50 %

The maximum value depends on the rated motor current, parameter 105 *Motor current*, $I_{M,N}$.

Function:

The motor can be preheated at stop by means of a DC current to prevent moisture from entering the motor.

Description of choice:

The motor can be preheated by means of a DC current. At 0%, the function is inactive; at a value higher than 0%, a DC current will be supplied to the motor at stop (0 Hz). This function can also be used to generate a holding torque.



If too high a DC current is supplied for too long, the motor can be damaged.

★ = factory setting. () = display text [] = value for use in communication via serial communication port

■ DC braking

In DC braking, the motor receives a DC current that brings the shaft to a halt. Parameter 114 *DC braking current*, decides the DC braking current as a percentage of the rated motor current $I_{M,N}$. In parameter 115 *DC braking time*, the DC braking time is selected, and in parameter 116 *DC brake cut-in frequency*, the frequency is selected at which DC braking becomes active. If terminal 19 or 27 (parameter 303/304 *Digital input*) has been programmed to *DC braking inverse* and shifts from logic "1" to logic "0", the DC braking will be activated. When the start signal on terminal 18 changes from logic "1" to logic "0", the DC braking will be activated when the output frequency becomes lower than the brake coupling frequency.



NB!:

The DC brake is not to be used if the inertia of the motor shaft is more than 20 times the inertia of the motor itself.

114 DC braking current

(DC BRAKE CURRENT)

Value:

$0 - \frac{I_{VLT,MAX}}{I_{M,N}} \times 100$ [%] ★ 50 %

The maximum value depends on the rated motor current. If the DC braking current is active, the frequency converter has a switching frequency of 4 kHz.

Function:

This parameter is used for setting the DC braking current that is activated upon a stop when the DC brake frequency set in parameter 116, *DC brake cut-in frequency* has been reached, or if DC brake inverse is active via terminal 27 or via the serial communication port. The DC braking current will be active for the duration of the DC braking time set in parameter 115 *DC braking time*.

Description of choice:

To be set as a percentage value of the rated motor current $I_{M,N}$ set in parameter 105 Motor current, $I_{VLT,N}$. 100% DC braking current corresponds to $I_{M,N}$.



Make sure not to supply too high a braking current for too long. The motor will be damaged because of mechanical overload or the heat generated in the motor.

115 DC braking time

(DC BRAKE TIME)

Value:

0.0 - 60.0 sec. ★ 10 sec.

Function:

This parameter is for setting the DC braking time for which the DC braking current (parameter 113) is to be active.

Description of choice:

Set the desired time.

116 DC brake cut-in frequency

(DC BRAKE CUT-IN)

Value:

0.0 (OFF) - par. 202
Output frequency high limit, f_{MAX} ★ OFF

Function:

This parameter is used for setting the DC brake cut-in frequency at which DC braking is to be activated in connection with a stop command.

Description of choice:

Set the desired frequency.

117 Motor thermal protection

(MOT. THERM PROTEC)

Value:

- No protection (NO PROTECTION) [0]
- Thermistor warning (THERMISTOR WARNING) [1]
- Thermistor trip (THERMISTOR FAULT) [2]
- ETR Warning 1 (ETR WARNING 1) [3]
- ★ETR Trip 1 (ETR TRIP 1) [4]
- ETR Warning 2 (ETR WARNING 2) [5]
- ETR Trip 2 (ETR TRIP 2) [6]
- ETR Warning 3 (ETR WARNING 3) [7]
- ETR Trip 3 (ETR TRIP 3) [8]
- ETR Warning 4 (ETR WARNING 4) [9]
- ETR Trip 4 (ETR TRIP 4) [10]

Function:

The frequency converter is able to monitor the motor temperature in two different ways:

- Via a thermistor sensor fitted to the motor. The thermistor is connected to one of the analog input terminals 53 and 54.

★ = factory setting. () = display text [] = value for use in communication via serial communication port

- Calculation of the thermal load (ETR - Electronic Thermal Relay), based on the current load and the time. This is compared with the rated motor current $I_{M,N}$ and the rated motor frequency $f_{M,N}$. The calculations made take into account the need for a lower load at lower speeds because of less cooling in the motor itself.

ETR functions 1-4 do not start calculating the load until there is a switch-over to the Setup in which they were selected. This enables the use of the ETR function, even where two or several motors alternate.

Description of choice:

Select *No protection* [0] if no warning or tripping is required when the motor is overloaded.
 Select *Thermistor warning* [1] if a warning is desired when the connected thermistor gets too hot.
 Select *Thermistor trip* [2] if cutting out (trip) is desired when the connected thermistor overheats.
 Select *ETR Warning 1-4*, if a warning is to come up on the display when the motor is overloaded according to the calculations.
 The frequency converter can also be programmed to give off a warning signal via one of the digital outputs. Select *ETR Trip 1-4* if tripping is desired when the motor is overloaded according to the calculations.

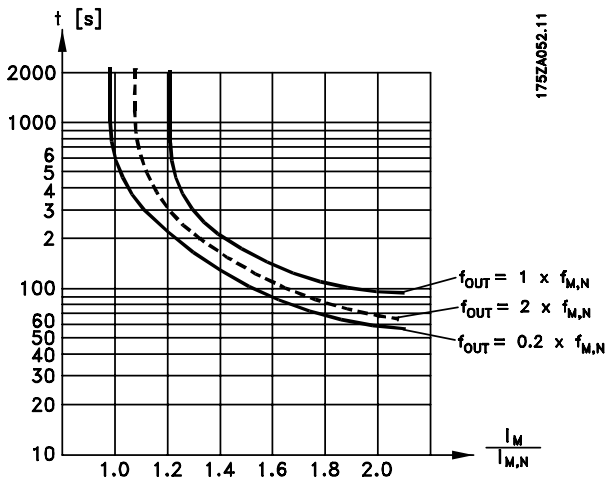

NB!:

In UL / cUL applications ETR provides class 20 motor overload protection in accordance with National Electrical Code.

118 Motor power factor (Cos φ)

(MOTOR PWR FACT)

Value:

0.50 - 0.99

★ 0.75

Function:

This parameter calibrates and optimizes the AEO function for motors of different power factor (Cos φ).

Description of choice:

Motors having > 4 poles have a lower power factor which would restrict or prevent use of the AEO function for energy savings. This parameter allows the user to calibrate the AEO function to the power factor of the motor so that AEO can be used with motors of 6, 8, and 12 poles as well as 4 and 2 poles.



NB!:

The default value is 0.75 and should **NOT** be changed unless the specific motor has power factor lower than 0.75. This is typically the case for motors having more than 4 poles or low efficiency motors.

119 Load compensation at low speed

(LOAD COMP LO SPD)

Value:

0 - 300 %

★ 100 %

Function:

This parameter enables compensation of voltage in relation to load when the motor is running at low speed.

Description of choice:

Optimum U/f characteristics are obtained, i.e. compensation for the load at low speed. The frequency range within which *Load compensation at low speed* is active, depends on the motor size. This function is active for:

Motor size	Change-over
0.5 kW (.75 HP) - 7.5 kW (10 HP)	< 10 Hz
11 kW (15 HP) - 45 kW (60 HP)	< 5 Hz
55 kW (75 HP) - 355 kW (600 HP)	< 3-4 Hz

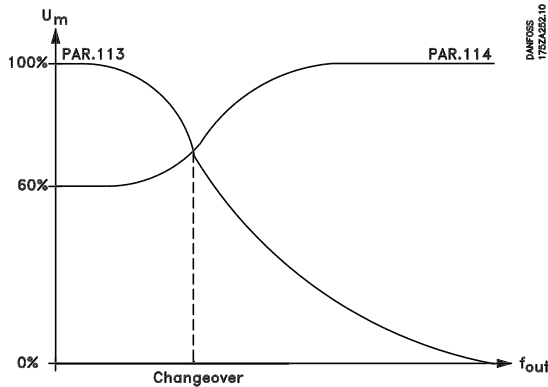

120 Load compensation at high speed (LOAD COMP HI SPD)

Value:

0 - 300 % ★ 100 %

Function:

This parameter enables compensation of voltage in relation to load when the motor is running at high speed.

Description of choice:

In *Load compensation at high speed* it is possible to compensate for the load from the frequency where *Load compensation at low speed* stopped working to max.frequency.

This function is active for:

Motor size	Change-over
0.5 kW - 7.5 kW	>10 Hz
11 kW - 45 kW	>5 Hz
55 kW - 355 kW	>3-4 Hz

121 Slip compensation (SLIP COMPENSAT.)

Value:

-500 - 500 % ★ 100 %

Function:

Slip compensation is calculated automatically, i.e. on the basis of the rated motor speed $n_{M,N}$.

In parameter 121, slip compensation can be adjusted in detail, which compensates for tolerances in the value of $n_{M,N}$.

This function is not active together with *Variable torque* (parameter 101 - variable torque graphs), *Torque control*, *Speed feedback* and *Special motor characteristics*.

Description of choice:

Enter a %-value of the rated motor frequency (parameter 104).

122 Slip compensation time constant (SLIP TIME CONST.)

Value:

0.05 - 5.00 sec. ★ 0.50 sec.

Function:

This parameter determines the slip compensation reaction speed.

Description of choice:

A high value results in slow reaction. Conversely, a low value results in quick reaction.

If low-frequency resonance problems are encountered, the time set must be longer.

123 Stator resistance (STATOR RESIST)

Value:

★Depends on the choice of motor

Function:

After setting motor data in parameters 102-106, a number of adjustments of various parameters are made automatically, including the stator resistance R_S . A manually entered R_S must apply to a cold motor. The shaft performance can be improved by fine-tuning R_S and X_S , see procedure below.

Description of choice:

R_S can be set as follows:

1. Automatic motor adaptation, where the frequency converter actually tests the motor to determine this value. All compensations are reset to 100%.
2. The values are stated by the motor supplier.
3. The values are obtained by means of manual measurements:
 - R_S can be calculated by measuring the resistance $R_{PHASE-to-PHASE}$ between two phase terminals. If $R_{PHASE-to-PHASE}$ is lower than 1-2 ohm (typically motors > 4 (5.4 HP) - 5.5 kW (7.4 HP), 400 V), a special ohm-meter should be used (Thomson bridge or similar). $R_S = 0.5 \times R_{PHASE-to-PHASE}$
4. The factory settings of R_S , selected by the frequency converter itself on the basis of the motor nameplate data, are used.

★ = factory setting. () = display text [] = value for use in communication via serial communication port

124 Stator reactance

(STATOR REACT.)

Value:

★depends on the choice of motor

Function:

After setting motor data in parameters 102-106, a number of adjustments of various parameters are made automatically, including the stator resistance X_S . The shaft performance can be improved by fine-tuning R_S and X_S , see procedure below.

Description of choice:

X_S can be set as follows:

1. Automatic motor adaptation, where the frequency converter actually tests the motor to determine this value. All compensations are reset to 100%.
2. The values are stated by the motor supplier.
3. These values are obtained by means of manual measurements:
 - X_S can be calculated by connecting a motor to mains and measuring the phase-to-phase voltage U_L as well as the idling current I . Alternatively, these values can be recorded during operation in idle running state at the rated motor frequency $f_{M,N}$, slip compensation (par. 115) = 0% and load compensation at high speed (par. 114) = 100%.

$$X_S = \frac{U_L}{\sqrt{3} \times I \Phi}$$

4. The factory settings of X_S , selected by the frequency converter itself on the basis of the motor nameplate data, are used.

★ = factory setting. () = display text [] = value for use in communication via serial communication port

■ References and Limits 200-228

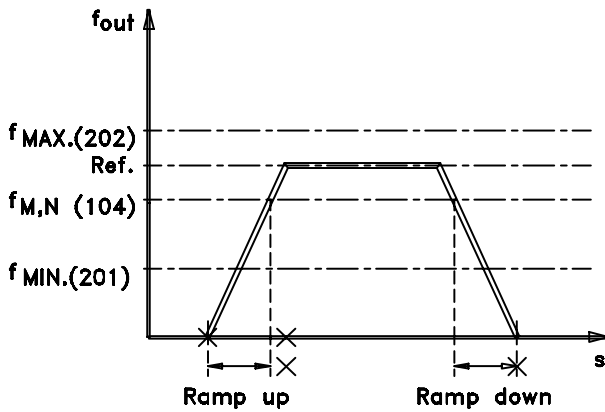

175HA334.10

In this parameter group, the frequency and reference range of the frequency converter are established.

This parameter group also includes:

- Setting of ramp times
- Choice of four preset references
- Possibility of programming four bypass frequencies.
- Setting of maximum current to motor.
- Setting of warning limits for current, frequency, reference and feedback.



NB!:

The output frequency of the frequency converter can never assume a value higher than 1/10 of the switching frequency (parameter 407 *Switching frequency*).

Description of choice:

A value from f_{MIN} to the choice made in parameter 200 *Output frequency range* can be selected.

201 Output frequency low limit, f_{MIN}

(MIN. FREQUENCY)

Value:

0.0 - f_{MAX} ★ 0.0 HZ

Function:

This is where to select the minimum output frequency.

Description of choice:

A value from 0.0 Hz to the *Output frequency high limit*, f_{MAX} frequency set in parameter 202 can be selected.

202 Output frequency high limit, f_{MAX}

(MAX. FREQUENCY)

Value:

f_{MIN} - 120 Hz
(par. 200 *Output frequency range*)
★ 60 Hz/▼ 50 Hz

▼) Global factory setting different from North American factory setting.)

Function:

In this parameter, a maximum output frequency can be selected that corresponds to the highest speed at which the motor can be.

★ = factory setting. () = display text [] = value for use in communication via serial communication port

Reference handling

Reference handling is shown in the block diagram underneath.

The block diagram shows how a change in a parameter can affect the resulting reference.

Parameters 203 to 205 *Reference handling, minimum and maximum reference* and parameter 210 *Reference type* define the way reference handling can be carried out. The mentioned parameters are active both in a closed and in an open loop.

Remote references are defined as:

- External references, such as analog inputs 53, 54 and 60, pulse reference via terminal 17/29 and reference from serial communication.
- Preset references.

The resulting reference can be shown in the display by selecting *Reference [%]* in parameters 007-010 *Display readout* and in the form of a unit by selecting *Resulting reference [unit]*. See the section on *Feedback handling* in connection with a closed loop.

The sum of the external references can be shown in the display as a percentage of the range from *Minimum reference, Ref_{MIN}* to *Maximum reference, Ref_{MAX}*. Select *External reference, % [25]* in parameters 007-010 *Display readout* if a readout is required.

It is possible to have both preset references and external references at the same time. In parameter 210 *Reference type* a choice is made of how the preset references are to be added to the external references.

Furthermore, an independent local reference exists, where the resulting reference is set by means of the [+/-] keys. If local reference has been selected, the output frequency range is limited by parameter 201 *Output frequency low limit, f_{MIN}* and parameter 202 *Output frequency high limit, f_{MAX}*.



NB!

If the local reference is active, the frequency converter will always be in *Open loop* [0], regardless of the choice made in parameter 100 *Configuration*.

The unit of the local reference can be set either as Hz or as a percentage of the output frequency range. The unit is selected in parameter 011 *Unit of local reference*.

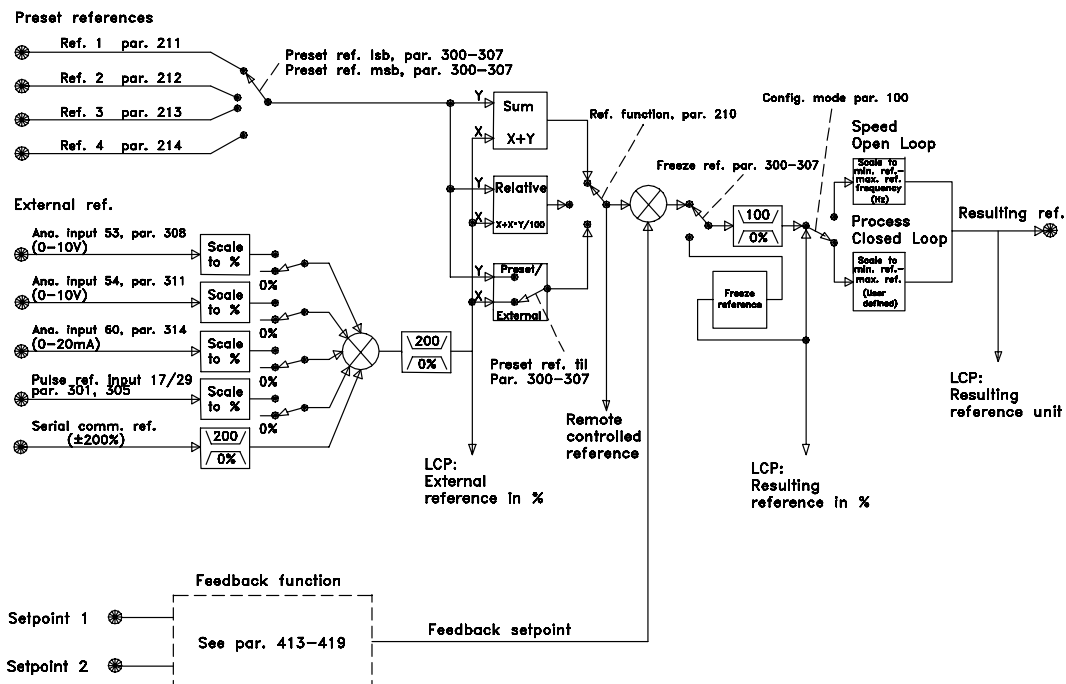

175HA375.14

★ = factory setting. () = display text [] = value for use in communication via serial communication port

203 Reference site

(REFERENCE SITE)

Value:

★Hand/Auto linked reference (LINKED TO HAND/AUTO)	[0]
Remote reference (REMOTE)	[1]
Local reference (LOCAL)	[2]

Function:

This parameter determines the location of the active reference. If *Hand/Auto linked reference* [0] is selected, the resulting reference will depend on whether the frequency converter is in Hand or Auto mode.

The table shows which references are active when *Hand/Auto linked reference* [0], *Remote reference* [1] or *Local reference* [2] has been selected. The Hand mode or Auto mode can be selected via the control keys or via a digital input, parameters 300-307 *Digital inputs*.

Reference handling	Reference	
	Hand mode	Auto mode
Hand/Auto [0]	Local ref. active	Remote ref. active
Remote [1]	Remote ref. active	Remote ref. active
Local [2]	Local ref. active	Local ref. active

Description of choice:

If *Hand/Auto linked reference* [0] is chosen, the motor speed in Hand mode will be decided by the local reference, while in Auto mode it depends on remote references and any setpoints selected.

If *Remote reference* [1] is selected, the motor speed will depend on remote references, regardless of whether Hand mode or Auto mode has been chosen. If *Local reference* [2] is selected, the motor speed will only depend on the local reference set via the control panel, regardless of whether Hand mode or Auto mode has been selected.

204 Minimum reference, Ref_{MIN}

(MIN. REFERENCE)

Value:

Parameter 100 *Configuration = Open loop* [0].
0.000 - parameter 205 Ref_{MAX} ★ 0.000 Hz
Parameter 100 *Configuration = Closed loop* [1].
-Par. 413 *Minimum feedback*
- par. 205 Ref_{MAX} ★ 0.000

Function:

The *Minimum reference* gives the minimum value that can be assumed by the sum of all references. If *Closed loop* has been selected in parameter 100 *Configuration*, the minimum reference is limited by parameter 413 *Minimum feedback*.

Minimum reference is ignored when the local reference is active (parameter 203 *Reference site*). The unit for the reference can be seen from the following table:

	Unit
Par. 100 <i>Configuration = Open loop</i>	Hz
Par. 100 <i>Configuration = Closed loop</i>	Par. 415

Description of choice:

Minimum reference is set if the motor is to run at a minimum speed, regardless of whether the resulting reference is 0.

205 Maximum reference, Ref_{MAX}

(MAX. REFERENCE)

Value:

Parameter 100 *Configuration = Open loop* [0]
Parameter 204 Ref_{MIN} - 1000.000 Hz
★ 60 Hz/50 Hz
Parameter 100 *Configuration = Closed loop* [1]
Par. 204 Ref_{MIN}
- par. 414 *Maximum feedback* ★ 60 Hz/▼ 50 Hz
▼) Global factory setting different from North American factory setting).

Function:

The *Maximum reference* gives the maximum value that can be assumed by the sum of all references. If *Closed loop* [1] has been selected in parameter 100 *Configuration*, the maximum reference cannot be set above parameter 414 *Maximum feedback*. The *Maximum reference* is ignored when the local reference is active (parameter 203 *Reference site*).

The reference unit can be determined on the basis of the following table:

	Unit
Par. 100 <i>Configuration = Open loop</i>	Hz
Par. 100 <i>Configuration = Closed loop</i>	Par. 415

Description of choice:

Maximum reference is set if the motor speed is not to exceed the set value, regardless of whether the resulting reference is higher than *Maximum reference*.

206 Ramp-up time

(RAMP UP TIME)

Value:

1 - 3600 sec. ★ Depends on the unit

Function:

The ramp-up time is the acceleration time from 0 Hz to the rated motor frequency $f_{M,N}$ (parameter 104 *Motor frequency, $f_{M,N}$*). It is assumed that the output current does not reach the current limit (set in parameter 215 *Current limit I_{LIM}*).

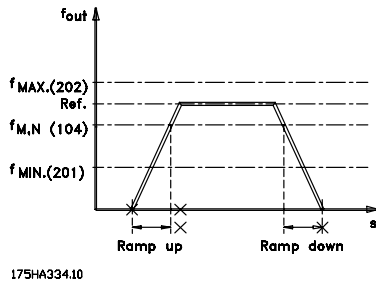

Description of choice:

Program the desired ramp-up time.

207 Ramp-down time

(RAMP DOWN TIME)

Value:

1 - 3600 sec. ★ Depends on the unit

Function:

The ramp-down time is the deceleration time from the rated motor frequency $f_{M,N}$ (parameter 104 *Motor frequency, $f_{M,N}$*) to 0 Hz, provided there is no overvoltage in the inverter because of the motor acting as a generator.

Description of choice:

Program the desired ramp-down time.

208 Automatic ramp-down

(AUTO RAMPING)

Value:

Disable (DISABLE) [0]
 ★Enable (ENABLE) [1]

Function:

This function ensures that the frequency converter does not trip during deceleration if the ramp-down time set is too short. If, during deceleration, the frequency converter registers that the intermediate circuit voltage is higher than the max. value (see *list*

of warnings and alarms), the frequency converter automatically extends the ramp-down time.



NBI:

If the function is chosen as *Enable* [1], the ramp time may be considerably extended in relation to the time set in parameter 207 *Ramp-down time*.

Description of choice:

Program this function as *Enable* [1] if the frequency converter periodically trips during ramp-down. If a quick ramp-down time has been programmed that may lead to a trip under special conditions, the function can be set to *Enable* [1] to avoid trips.

209 Jog frequency

(JOG FREQUENCY)

Value:

Par. 201 *Output frequency Low limit* - par.
 202 *Output frequency high limit* ★ 10.0 HZ

Function:

The jog frequency f_{JOG} is the fixed output frequency at which the frequency converter is running when the jog function is activated. Jog can be activated via the digital inputs.

Description of choice:

Set the desired frequency.

★ = factory setting. () = display text [] = value for use in communication via serial communication port

■ Reference type

The example shows how the resulting reference is calculated when Preset references are used together with Sum and Relative in parameter 210 Reference type. See *Calculation of resulting reference*. See also the drawing in *Reference handling*.

The following parameters have been set:

Par. 204 <i>Minimum reference</i> :	10 Hz
Par. 205 <i>Maximum reference</i> :	50 Hz
Par. 211 <i>Preset reference</i> :	15%
Par. 308 <i>Terminal 53, analog input</i> :	Reference [1]
Par. 309 <i>Terminal 53, min. scaling</i> :	0 V
Par. 310 <i>Terminal 53, max. scaling</i> :	10 V

When parameter 210 *Reference type* is set to Sum [0], one of the adjusted *Preset references* (par. 211-214) will be added to the external references as a percentage of the reference range. If terminal 53 is energized by an analog input voltage of 4 V, the resulting reference will be as follows:

Par. 210 <i>Reference type</i> = Sum [0]	
Par. 204 <i>Minimum reference</i>	= 10.0 Hz
Reference contribution at 4 V	= 16.0 Hz
Par. 211 <i>Preset reference</i>	= 6.0 Hz
Resulting reference	= 32.0 Hz

If parameter 210 *Reference type* is set to *Relative* [1], one of the adjusted *Preset references* (par. 211-214) will be totaled as a percentage of the sum of the present external references. If terminal 53 is energized by an analog input voltage of 4 V, the resulting reference will be as follows:

Par. 210 <i>Reference type</i> = <i>Relative</i> [1]	
Par. 204 <i>Minimum reference</i>	= 10.0 Hz
Reference contribution at 4 V	= 16.0 Hz
Par. 211 <i>Preset reference</i>	= 2.4 Hz
Resulting reference	= 28.4 Hz

The graph in the next column shows the resulting reference in relation to the external reference varied from 0-10 V. Parameter 210 *Reference type* has been programmed for *Sum* [0] and *Relative* [1], respectively. In addition, a graph is shown in which parameter 211 *Preset reference* 1 is programmed for 0%.

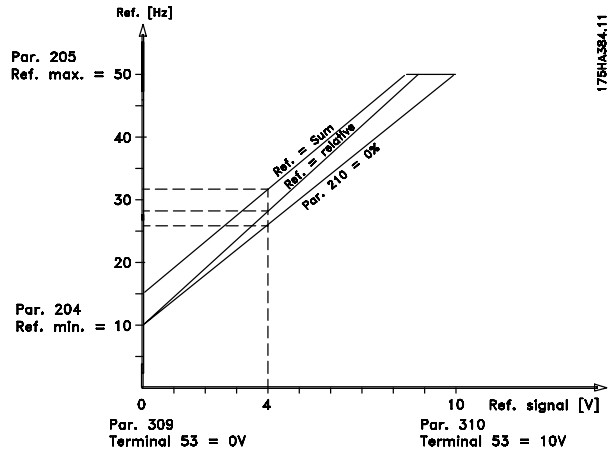

210 Reference type

(REF. FUNCTION)

Value:

★Sum (SUM)	[0]
Relative (RELATIVE)	[1]
External/preset (EXTERNAL/PRESET)	[2]

Function:

It is possible to define how the preset references are to be added to the other references. For this purpose, *Sum* or *Relative* is used. It is also possible - by using the *External/preset* function - to select whether a shift between external references and preset references is wanted. See *Reference handling* .

Description of choice:

If *Sum* [0] is selected, one of the adjusted preset references (parameters 211-214 *Preset reference*) is added to the other external references as a percentage of the reference range (Ref_{MIN}-Ref_{MAX}).

If *Relative* [1] is selected, one of the adjusted preset references (parameters 211-214 *Preset reference*) is totaled as a percentage of the sum of the present external references.

If *External/preset* [2] is selected, it is possible to shift between external references and preset references via terminal 16, 17, 29, 32 or 33 (parameter 300, 301, 305, 306 or 307 *Digital inputs*). Preset references will be a percentage value of the reference range. External reference is the sum of the analog references, pulse references and any references from serial communication.

★ = factory setting. () = display text [] = value for use in communication via serial communication port



NB!:

If *Sum* or *Relative* is selected, one of the preset references will always be active. If the preset references are to be without influence, they should be set to 0% (as in the factory setting) via the serial communication port.

211 Preset reference 1 (PRESET REF. 1)

212 Preset reference 2 (PRESET REF. 2)

213 Preset reference 3 (PRESET REF. 3)

214 Preset reference 4 (PRESET REF. 4)

Value:

-100.00 % - +100.00 % ★ 0.00%
of the reference range/external reference

Function:

Four different preset references can be programmed in parameters 211-214 *Preset reference*. The preset reference is stated as a percentage value of the reference range (Ref_{MIN} - Ref_{MAX}) or as a percentage of the other external references, depending on the choice made in parameter 210 *Reference type*. The choice between the preset references can be made by activating terminal 16, 17, 29, 32 or 33, cf. the table below.

Terminal 17/29/33 preset ref. msb	Terminal 16/29/32 preset ref. lsb	
0	0	Preset ref. 1
0	1	Preset ref. 2
1	0	Preset ref. 3
1	1	Preset ref. 4

Description of choice:

Set the required preset reference(s) that is/are to be the options.

215 Current limit, I_{LIM} (CURRENT LIMIT)

Value:

0.1 - 1.1 x I_{VLT,N} ★ 1.0 x I_{VLT,N} [A]

Function:

This is where the maximum output current I_{LIM} is set. The factory setting corresponds to the rated output current. If the current limit is to be used as motor protection, the rated motor current must be set. If

★ = factory setting. () = display text [] = value for use in communication via serial communication port

the current limit is set within the range of 1.0-1.1 x I_{VLT,N} (the rated output current of the frequency converter), the frequency converter can only handle a load intermittently, i.e. for short periods at a time. After the load has been higher than I_{VLT,N}, it must be ensured that for a period the load is lower than I_{VLT,N}. Please note that if the current limit is set to less than I_{VLT,N}, the acceleration torque will be reduced correspondingly.

Description of choice:

Set the required maximum output current I_{LIM}.

216 Frequency bypass, bandwidth (FREQUENCY BYPASS B.W)

Value:

0 (OFF) - 100 Hz ★ Disable

Function:

Some systems call for some output frequencies to be avoided because of mechanical resonance problems in the system. These output frequencies can be programmed in parameters 217-220 *Frequency bypass*. In this parameter (216 *Frequency bypass, bandwidth*), a definition can be given of a bandwidth around each of these frequencies.

Description of choice:

The bypass bandwidth is equal to the programmed bandwidth frequency. This bandwidth will be centered around each bypass frequency.

217 Frequency bypass 1 (BYPASS FREQ. 1)

218 Frequency bypass 2 (BYPASS FREQ. 2)

219 Frequency bypass 3 (BYPASS FREQ. 3)

220 Frequency bypass 4 (BYPASS FREQ. 4)

Value:

0 - 120 HZ ★ 120.0 Hz

Function:

Some systems call for some output frequencies to be avoided because of mechanical resonance problems in the system.

Description of choice:

Enter the frequencies to be avoided.

See also parameter 216 *Frequency bypass, bandwidth*.

221 Warning: Low current, I_{LOW}

(WARN. LOW CURR.)

Value:

0.0 - par. 222 *Warning: High current I_{HIGH}* , ★ 0.0A

Function:

When the motor current is below the limit, I_{LOW} , programmed in this parameter, the display shows a flashing CURRENT LOW, provided *Warning [1]* has been selected in parameter 409 *Function in case of no load*. The frequency converter will trip if parameter 409 *Function in case of no load* has been selected as *Trip [0]*.

The warning functions in parameters 221-228 are not active during ramp-up after a start command, ramp-down after a stop command or while stopped. The warning functions are activated when the output frequency has reached the resulting reference. The signal outputs can be programmed to generate a warning signal via terminal 42 or 45 and via the relay outputs.

Description of choice:

The lower signal limit I_{LOW} must be programmed within the normal working range of the frequency converter.

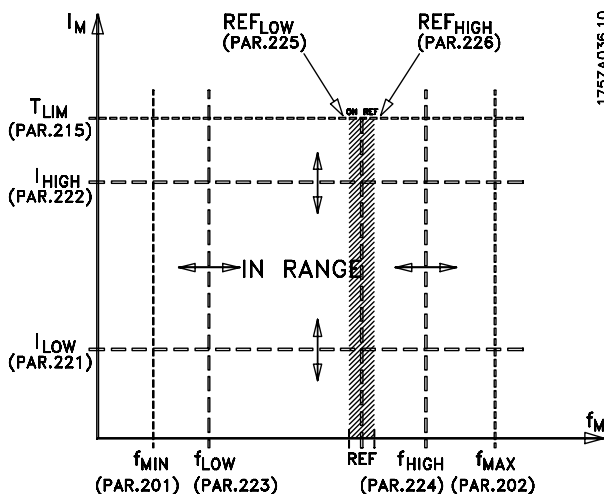

222 Warning: High current, I_{HIGH}

(WARN. HIGH CURR.)

Value:

Parameter 221 - $I_{VLT,MAX}$ ★ $I_{VLT,MAX}$

Function:

If the motor current is above the limit, I_{HIGH} , programmed in this parameter, the display shows a flashing CURRENT HIGH.

★ = factory setting. () = display text [] = value for use in communication via serial communication port

The warning functions in parameters 221-228 are not active during ramp-up after a start command, ramp-down after a stop command or while stopped. The warning functions are activated when the output frequency has reached the resulting reference. The signal outputs can be programmed to generate a warning signal via terminal 42 or 45 and via the relay outputs.

Description of choice:

The upper signal limit of the motor frequency, f_{HIGH} , must be programmed within the normal working range of the frequency converter. See drawing at parameter 221 *Warning: Low current, I_{LOW}* .

223 Warning: Low frequency, f_{LOW}

(WARN. LOW FREQ.)

Value:

0.0 - parameter 224 ★ 0.0 Hz

Function:

If the output frequency is below the limit, f_{LOW} , programmed in this parameter, the display will show a flashing FREQUENCY LOW.

The warning functions in parameters 221-228 are not active during ramp-up after a start command, ramp-down after a stop command or while stopped. The warning functions are activated when the output frequency has reached the selected reference. The signal outputs can be programmed to generate a warning signal via terminal 42 or 45 and via the relay outputs.

Description of choice:

The lower signal limit of the motor frequency, f_{LOW} , must be programmed within the normal working range of the frequency converter. See drawing at parameter 221 *Warning: Low current, I_{LOW}* .

224 Warning: High frequency, f_{HIGH}

(WARN. HIGH FREQ.)

Value:

Par. 200 *Output frequency range* = 0-120 Hz [0].
parameter 223 - 120 Hz ★ 120.0 Hz

Function:

If the output frequency is above the limit, f_{HIGH} , programmed in this parameter, the display will show a flashing FREQUENCY HIGH.

The warning functions in parameters 221-228 are not active during ramp-up after a start command,

ramp-down after a stop command or while stopped. The warning functions are activated when the output frequency has reached the selected reference. The signal outputs can be programmed to generate a warning signal via terminal 42 or 45 and via the relay outputs.

Description of choice:

The higher signal limit of the motor frequency, f_{HIGH} , must be programmed within the normal working range of the frequency converter. See drawing at parameter 221 *Warning: Low current, I_{LOW}* .

**225 Warning: Low reference, REF_{LOW}
(WARN. LOW REF.)**

Value:

-999,999.999 - REF_{HIGH} (par.226) ★ -999,999.999

Function:

When the remote reference lies under the limit, Ref_{LOW} , programmed in this parameter, the display shows a flashing REFERENCE LOW.

The warning functions in parameters 221-228 are not active during ramp-up after a start command, ramp-down after a stop command or while stopped. The warning functions are activated when the output frequency has reached the selected reference. The signal outputs can be programmed to generate a warning signal via terminal 42 or 45 and via the relay outputs.

The reference limits in parameter 226 *Warning: High reference, Ref_{HIGH}* , and in parameter 225 *Warning: Low reference, Ref_{LOW}* , are only active when remote reference has been selected. In *Open loop mode* the unit for the reference is Hz, while in *Closed loop mode* the unit is programmed in parameter 415 *Process units*.

Description of choice:

The lower signal limit, Ref_{LOW} , of the reference must be programmed within the normal working range of the frequency converter, provided parameter 100 *Configuration* has been programmed for *Open loop* [0]. In *Closed loop* [1] (parameter 100), Ref_{LOW} must be within the reference range programmed in parameters 204 and 205.

**226 Warning: High reference , REF_{HIGH}
(WARN. HIGH REF.)**

Value:

REF_{LOW} (par. 225) - 999,999.999 ★ 999,999.999

Function:

If the resulting reference is above the limit, Ref_{HIGH} , programmed in this parameter, the display shows a flashing REFERENCE HIGH.

The warning functions in parameters 221-228 are not active during ramp-up after a start command, ramp-down after a stop command or while stopped. The warning functions are activated when the output frequency has reached the resulting reference.

The signal outputs can be programmed to generate a warning signal via terminal 42 or 45 and via the relay outputs.

The reference limits in parameter 226 *Warning: High reference, Ref_{HIGH}* , and in parameter 225 *Warning: Low reference, Ref_{LOW}* , are only active when remote reference has been selected.

In *Open loop* the unit for the reference is Hz, while in *Closed loop* the unit is programmed in parameter 415 *Process units*.

Description of choice:

The upper signal limit, Ref_{HIGH} , of the reference must be programmed within the normal working range of the frequency converter, provided parameter 100 *Configuration* has been programmed for *Open loop* [0]. In *Closed loop* [1] (parameter 100), Ref_{HIGH} must be within the reference range programmed in parameters 204 and 205.

**227 Warning: Low feedback, FB_{LOW}
(WARN LOW FDBK)**

Value:

-999,999.999 - FB_{HIGH}
(parameter 228) ★ -999.999,999

Function:

If the feedback signal is below the limit, FB_{LOW} , programmed in this parameter, the display will show a flashing FEEDBACK LOW.

The warning functions in parameters 221-228 are not active during ramp-up after a start command, ramp-down after a stop command or while stopped. The warning functions are activated when the output frequency has reached the selected reference. The signal outputs can be programmed to generate a warning signal via terminal 42 or 45 and via the relay outputs.

Programming

★ = factory setting. () = display text [] = value for use in communication via serial communication port

In *Closed loop*, the unit for the feedback is programmed in parameter 415 *Process units*.

Description of choice:

Set the required value within the feedback range (parameter 413 *Minimum feedback*, FB_{MIN} , and 414 *Maximum feedback*, FB_{MAX}).

228 Warning: High feedback, FB_{HIGH}
(WARN. HIGH FDBK)

Value:

FB_{Low}
(parameter 227) - 999,999.999 ★ 999.999,999

Function:

If the feedback signal is above the limit, FB_{HIGH} , programmed in this parameter, the display will show a flashing FEEDBACK HIGH. The warning functions in parameters 221-228 are not active during ramp-up after a start command, ramp-down after a stop command or while stopped. The warning functions are activated when the output frequency has reached the selected reference. The signal outputs can be programmed to generate a warning signal via terminal 42 or 45 and via the relay outputs. In *Closed loop*, the unit for the feedback is programmed in parameter 415 *Process units*.

Description of choice:

Set the required value within the feedback range (parameter 413 *Minimum feedback*, FB_{MIN} , and 414 *Maximum feedback*, FB_{MAX}).

229 Initial ramp
(INITIAL RAMP)

Value:

OFF/000.1s - 360.0 s ★ OFF

Function:

Allows the motor/equipment to be brought up to minimum speed (frequency) at a rate different than the normal Ramp-Up rate (param. 206).

Description of choice:

As an example, vertical pumps and other equipment often have a requirement to not operate below a minimum speed any longer than necessary. Damage and excessive wear can occur when operating below minimum speed (frequency) for too long a period of time. The Initial Ramp is used to quickly accelerate the

motor/equipment to minimum speed at which point, the normal Ramp-Up rate (parameter 206) is made active. The range of adjustment of the Initial Ramp is from 000.1 second to 360.0 seconds; adjustable in 0.1 second increments. If this parameter is set to 000.0, OFF is displayed in this parameter, the Initial Ramp is not active, and the normal Ramp-Up is active.

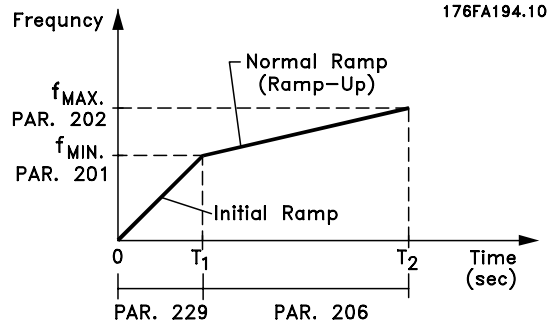

■ Fill Mode

Fill Mode eliminates the occurrence of water hammer associated with the rapid exhausting of air from piping systems (such as Irrigation systems).

The frequency converter, set for Closed Loop operation uses an adjustable Fill Rate, a "Filled Pressure" setpoint, an operating pressure setpoint, and a pressure feedback.

Fill Mode is available when:

- The VLT 8000 AQUA drive is in **Closed Loop** mode (parameter 100).
- Parameter 230 is **not 0**
- Parameter 420 is set to **NORMAL**

After a start command, Fill Mode operation begins when the frequency converter reaches minimum frequency - set in parameter 201.

The "Filled" Setpoint - parameter 231 - is actually a setpoint limit. When minimum speed is reached, the pressure feedback is looked at, and the frequency converter begins to ramp to the "Filled" pressure setpoint at the rate established by Fill Rate parameter 230.

The Fill Rate - parameter 230 - is dimensioned in Units/Second. The Units will be the units selected in parameter 415.

When the pressure feedback equals the "Filled" Setpoint, the control transitions to the operating setpoint (Setpoint 1 - param. 418 or Setpoint 2 - param. 419) and continues operation in standard (normal) "closed loop" mode.

★ = factory setting. () = display text [] = value for use in communication via serial communication port

The value to use for the "Filled" Setpoint parameter 231, can be determined by:

1. Use the DISPLAY MODE key on the LCP to display **FEEDBACK 1**.
IMPORTANT! Be sure that you have selected the UNITS in parameter 415 before this step.
2. Operate the VLT 8000 AQUA in **HAND** mode and slowly advance the speed to fill the pipe while being careful not to create a water hammer.
3. An observer at the end of the pipe must be able to report when the pipe is filled.
4. At that instant, stop the motor, and observe the value of pressure feedback (have the LCP display set to observe the feedback before starting).
5. The value of feedback in step 4) is the value to use in parameter 231 - "Filled" Setpoint.

The value to set in parameter 230 - Fill Rate can be supplied by the system engineer from proper calculation or from experience, or it can be determined experimentally by performing numerous fill mode sequences and either increasing or decreasing the value of this parameter to obtain the fastest fill without causing a water hammer.

The **Fill Mode** is also beneficial when bringing the motor to a stop as it prevents sudden changes in pressure and flow which could also cause a water hammer.

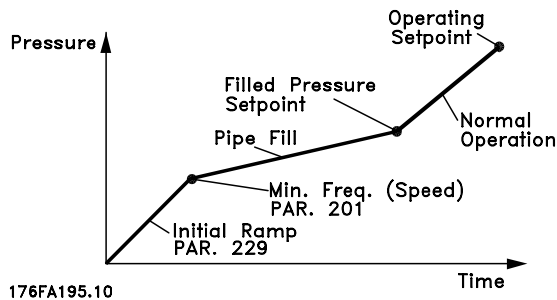

230 Fill Rate

(FILL RATE)

Value:

OFF/000000.001 - 999999.999 (units/s) - ★ OFF

Function:

Establishes the rate at which the pipe is filled.

Description of choice:

The dimension of this parameter is Units/Second. The Units will be the value selected in parameter 415.

As an example, the Units could be Bar, or MPa, or PSI, etc. If Bar is the selected unit in parameter 415, then the number set in this parameter (230) would

be dimensioned as Bar/Second. Changes to this parameter can be made in steps of .001 units.

231 Filled Setpoint

(FILLED SETPOINT)

Value:

Param. 413 - Param. 205 - ★ Param. 413

Function:

The value set in this parameter corresponds to the pressure that exists at the pressure sensor when the pipe is filled.

Description of choice:

The Units of this parameter correspond to the units selected in Parameter 415. The minimum value of this parameter is Fb_{min} (param. 413). The maximum value for this parameter is Ref_{max} (param. 205). The setpoint can be changed in .01 steps.

Inputs and outputs 300-328

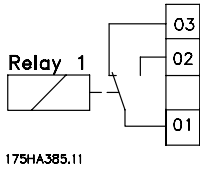

In this parameter group, the functions that relate to the input and output terminals of the frequency converter are defined. The digital inputs (terminals 16, 17, 18, 19, 27, 29, 32 and 33) are programmed in parameters 300-307.

The table below gives the options for programming the inputs. The digital inputs require a signal of 0 or 24 V DC. A signal lower than 5 V DC is a logic '0', while a signal higher than 10 V DC is a logic '1'. The terminals for the digital inputs can be connected to the internal 24 V DC supply, or an external 24 V DC supply can be connected. The drawings in the next column show one Setup using the internal 24 V DC supply and one Setup using an external 24 V DC supply.

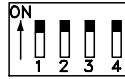
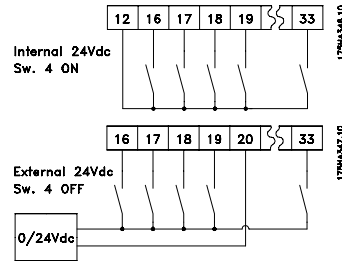

Switch 4, which is located on the Dip switch control card,

is used for separating the common potential of the internal 24 V DC supply from the common potential of the external 24 V DC supply. See *Electrical installation*.

Please note that when Switch 4 is in the OFF position, the external 24 V DC supply is galvanically isolated from the frequency converter.

Digital inputs	Terminal no.	16	17	18	19	27	29	32	33
	parameter	300	301	302	303	304	305	306	307
Value:									
No function	(NO OPERATION)	[0]	[0]	[0]	[0]		[0]	[0]★	[0]★
Reset	(RESET)	[1]★	[1]				[1]	[1]	[1]
Coasting stop, inverse	(COAST INVERSE)						[0]▼		
Reset and coasting stop, inverse	(RESET & COAST INVERS)					[1]			
Start	(START)			[1]★					
Reversing	(REVERSE)				[1]★				
Reverse and start	(START INVERSE)				[2]				
DC-braking, inverse	(DC BRAKE INVERSE)				[3]	[2]			
Safety interlock	(SAFETY INTERLOCK)					[3]★			
Freeze reference	(FREEZE REFERENCE)	[2]	[2]★				[2]	[2]	[2]
Freeze output	(FREEZE OUTPUT)	[3]	[3]				[3]	[3]	[3]
Selection of Setup, lsb	(SETUP SELECT LSB)	[4]					[4]	[4]	
Selection of Setup, msb	(SETUP SELECT MSB)		[4]				[5]		[4]
Preset reference, on	(PRESET REF. ON)	[5]	[5]				[6]	[5]	[5]
Preset reference, lsb	(PRESET REF. LSB)	[6]					[7]	[6]	
Preset reference, msb	(PRESET REF. MSB)		[6]				[8]		[6]
Speed down	(SPEED DOWN)		[7]				[9]		[7]
Speed up	(SPEED UP)	[7]					[10]	[7]	
Run permissive	(RUN PERMISSIVE)	[8]	[8]				[11]	[8]	[8]
Jog	(JOG)	[9]	[9]				[12]★	[9]	[9]
Data change lock	(PROGRAMMING LOCK)	[10]	[10]				[13]	[10]	[10]
Pulse reference	(PULSE REFERENCE)		[11]				[14]		
Pulse feedback	(PULSE FEEDBACK)								[11]
Hand start	(HAND START)	[11]	[12]				[15]	[11]	[12]
Auto start	(AUTO START)	[12]	[13]				[16]	[12]	[13]
Latched start	(LATCHED START)			[2]					
Off stop	(OFF STOP)						[17]	[13]	[14]
Stop inverse	(STOP INVERSE)						[19]	[14]	[15]
Motor alternation	(MOTOR ALTERNATION)	[15]	[16]				[20]	[15]	[16]

▼ Global default setting

Function:

In parameters 300-307 *Digital inputs* it is possible to choose between the different possible functions related

to the digital inputs (terminals 16-33). The functional options are given in the table on the previous page.

Description of choice:

No function is selected if the frequency converter is not to react to signals transmitted to the terminal.

★ = factory setting. () = display text [] = value for use in communication via serial communication port

Reset resets the frequency converter after an alarm; however, not all alarms can be reset (trip locked) cycling mains power supply. See table in *List of warnings and alarms*. Reset will be activated on the rising edge of the signal.

Coasting stop, inverse is used to force the frequency converter to "release" the motor immediately. the output transistors are "turned off" to remove power to the motor, allowing it to coast to stop. Logic "0" implements this mode.

Reset and coasting stop, inverse is used for activating coasting stop at the same time as reset. Logic "0" implements coasting stop and reset. Reset will be activated on the falling edge of the signal.

DC braking, inverse is used for stopping the motor by energizing it with a DC current for a given time, see parameters 114-116 *DC brake*. Please note that this function is only active if the value of parameters 114 *DC brake current* and 115 *DC braking time* is different from 0. Logic '0' implements DC braking. See *DC braking*.

Safety interlock has the same function as *Coasting stop, inverse*, but *Safety interlock* generates the alarm message EXTERNAL FAULT on the display when terminal 27 is logic '0'. The alarm message will also be active via digital outputs 42/45 and relay outputs 1/2, if programmed for *Safety interlock*. The alarm can be reset using a digital input or the [OFF/STOP] key.

Start is selected if a start/stop command is required. Logic "1" = start, logic "0" = stop.

Reversing is used for changing the direction of rotation of the motor shaft. Logic "0" will not implement reversing. Logic "1" will implement reversing. The reversing signal only changes the direction of rotation; it does not activate the start function. It can not be used in *Closed loop*.

Reversing and start is used for start/stop and reversing using the same signal. A start signal via terminal 18 at the same time is not allowed. Is not active together with *Closed loop*.

Freeze reference freezes the present reference. The frozen reference can now only be changed by means of *Speed up* or *Speed down*. The frozen reference is saved after a stop command and in case of mains failure.

Freeze output freezes the present output frequency (in Hz). The frozen output frequency can now only be changed by *Speed up* or *Speed down*.



NB!:

If Freeze output is active, the frequency converter cannot be stopped via terminal 18. The frequency converter can only be stopped when terminal 27 or terminal 19 has been programmed for *DC braking, inverse*.

Selection of Setup, Isb or **Selection of Setup, msb** enables a choice of one of the four Setups. However, this assumes that parameter 002 *Active Setup* has been set at *Multi Setup* [5].

	Setup, msb	Setup, Isb
Setup 1	0	0
Setup 2	0	1
Setup 3	1	0
Setup 4	1	1

Preset reference, on is used for switching between remote reference and preset reference. This assumes that *Remote/preset* [2] has been selected in parameter 210 *Reference type*. Logic "0" = remote references active; logic "1" = one of the four preset references is active in accordance with the table on the next page.

Preset reference, Isb and **Preset reference, msb** enables a choice of one of the four preset references, in accordance with the table below.

	Preset ref., msb	Preset ref., Isb
Preset ref. 1	0	0
Preset ref. 2	0	1
Preset ref. 3	1	0
Preset ref. 4	1	1

Speed up and **Speed down** are selected if digital control of the up/down speed is desired. This function is only active if *Freeze reference* or *Freeze output* has been selected.

As long as there is a logic "1" on the terminal selected for *Speed up*, the reference or the output frequency will increase by the *Ramp-up time* set in parameter 206.

As long as there is a logic "1" on the terminal selected for *Speed down*, the reference or the output frequency will decrease by the *Ramp-down time* set in parameter 207.

Pulses (logic "1" minimum high for 3 ms and a minimum pause of 3 ms) will lead to a change of speed of 0.1% (reference) or 0.1 Hz (output frequency).

★ = factory setting. () = display text [] = value for use in communication via serial communication port

Example:

	Terminal (16)	Terminal (17)	Freeze ref./ Freeze output
No speed change	0	0	1
Speed down	0	1	1
Speed up	1	0	1
Speed down	1	1	1

The speed reference, frozen via the control panel, can be changed even if the frequency converter has stopped. In addition, the frozen reference will be remembered in case of a mains failure.

Run permissive. There must be an active start signal via the terminal, where *Run permissive* has been programmed, before a start command can be accepted. *Run permissive* has a logic 'AND' function related to Start (terminal 18, parameter 302 *Terminal 18, Digital input*), which means that in order to start the motor, both conditions must be fulfilled. If *Run permissive* is programmed on several terminals, *Run permissive* must only be logic "1" on one of the terminals for the function to be carried out.

Jog is used to override the output frequency to the frequency set in parameter 209 *Jog frequency* and issue a start command. If local reference is active, the frequency converter will always be in *Open loop* [0], regardless of the selection made in parameter 100 *Configuration*.

Jog is not active if a stop command has been given via terminal 27.

Data change lock is selected if data changes to parameters are not to be made via the control unit; however, it will still be possible to carry out data changes via the bus.

Pulse reference is selected if a pulse sequence (frequency) is selected as a reference signal. 0 Hz corresponds to Ref_{MIN} , parameter 204 *Minimum reference, Ref_{MIN}*. The frequency set in parameter 327 *Pulse reference, max. frequency* corresponds to parameter 205 *Maximum reference, Ref_{MAX}*.

Pulse feedback is selected if a pulse sequence (frequency) is selected as a feedback signal. Parameter 328 *Pulse feedback, max. frequency* is where the maximum frequency for pulse feedback is set.

Hand start is selected if the frequency converter is to be controlled by means of an external hand/off or H-O-A switch. A logic '1' (Hand start active) will mean that the frequency converter starts the motor. A logic "0" means that the connected motor stops.

The frequency converter will then be in OFF/STOP mode, unless there is an active *Auto start signal*. See also the description in *Local control*.



NB!:

An active Hand and Auto signal via the digital inputs will have higher priority than the [HAND START]-[AUTO START] control keys.

Auto start is selected if the frequency converter is to be controlled via an external auto/off or H-O-A switch. A logic '1' will place the frequency converter in auto mode allowing a start signal on the control terminals or the serial communication port. If *Auto start* and *Hand start* are active at the same time on the control terminals, *Auto start* will have the highest priority. If *Auto start* and *Hand start* are not active, the connected motor will stop and the frequency converter will then be in OFF/STOP mode. See also the description in *Local control*.

Latched start will start the motor if a pulse is applied for a minimum of 3 ms, provided there is no stop command active. The motor will stop if *Stop Inverse* is briefly activated.

Off stop is used for stopping the connected motor. The stop will be effected in accordance with the selected ramp (par. 206 and 207).

Stop inverse is activated by interrupting the voltage to the terminal. This means that if the terminal has no voltage, the motor cannot run. The stop will be effected in accordance with the selected ramp (parameters 206 and 207).



None of the above-mentioned stop commands (start-disable) are to be used as disconnection switch in connection with repairs. Cut mains instead.

Motor alternation is used with the motor alternation function, see parameters 433 and 434 for further information. A signal will overrule the timer, and a forced alternation of the motor will take place. The timer resets after completion of the alternation sequence.

★ = factory setting. () = display text [] = value for use in communication via serial communication port

■ Analogue inputs

Two analogue inputs for voltage signals (terminals 53 and 54) are provided for reference and feedback signals. Furthermore, an analogue input is available for a current signal (terminal 60). A thermistor can be connected to voltage input 53 or 54. The two analogue voltage inputs can be scaled in the range of 0-10 V DC; the current input in the range of 0-20 mA.

The table below gives the possibilities for programming the analogue inputs. Parameter 317 *Time out* and 318 *Function after time out* allow activation of a time-out function on all analogue inputs. If the signal value of the reference or feedback signal connected to one of the analogue in-put terminals drops to below 50% of the minimum scaling, a function will be activated after the time out determined in parameter 318, *Function after time out*.

Analog inputs	terminal no.	53(voltage)	54(voltage)	60(current)
	parameter	308	311	314
Value:				
No operation	(NO OPERATION)	[0]	[0]★	[0]
Reference	(REFERENCE)	[1]★	[1]	[1] ★
Feedback	(FEEDBACK)	[2]	[2]	[2]
Thermistor	(THERMISTOR)	[3]	[3]	

308 Terminal 53, analog input voltage

(AI [V] 53 FUNCT.)

Function:

This parameter is used to select the required function to be linked to terminal 53.

Description of choice:

No operation Is selected if the frequency converter is not to react to signals connected to the terminal.

Reference Is selected to enable change of reference by means of an analog reference signal. If reference signals are connected to several inputs, these reference signals must be added up.

Feedback If a feedback signal is connected, there is a choice of a voltage input (terminal 53 or 54) or a current input (terminal 60) as feedback. In the case of zone regulation, feedback signals must be selected as voltage inputs (terminals 53 and 54). See *Feedback handling*.

Thermistor Is selected if a motor integrated thermistor (according to DIN44080/81) should stop the frequency converter in case of motor overtemperature. The cut-out value is 3 kohm. If a motor features a thermal switch instead, this can also be connected to the input. If motors run in parallel, the thermistors/thermal switches can be connected in series (total resistance < 3 kohm). Parameter 117 *Motor thermal protection* must be programmed for *Thermal warning* [1] or *Thermistor trip* [2], and the thermistor must be inserted between terminal 53 or 54 (analog voltage input) and terminal 50 (+10 V supply).

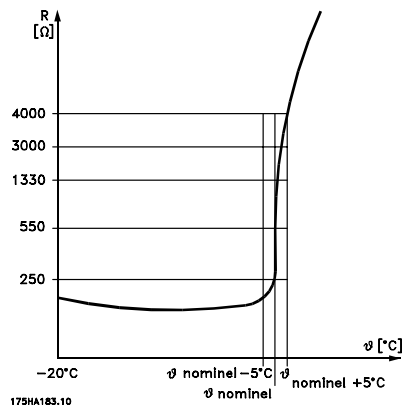

A motor thermistor connected to terminals 53/54 must be double isolated to obtain PELV.

★ = factory setting. () = display text [] = value for use in communication via serial communication port

309 Terminal 53, min. scaling
(AI 53 SCALE LOW)
Value:

 0.0 - 10.0 V ★ 0.0 V
Function:

This parameter is used for setting the signal value that has to correspond to the minimum reference or the minimum feedback, parameter 204 *Minimum reference*, Ref_{MIN} /413 *Minimum feedback*, FB_{MIN} . See *Reference handling* or *Feedback handling*.

Description of choice:

Set the required voltage value.
 For reasons of accuracy, voltage losses in long signal lines can be compensated for.
 If the time-out function is to be applied (parameters 317 *Time out* and 318 *Function after time out*), the value must be set to > 1 V.

310 Terminal 53, max. scaling
(AI 53 SCALE HIGH)
Value:

 0.0 - 10.0 V ★ 10.0 V
Function:

This parameter is used for setting the signal value that has to correspond to the maximum reference value or the maximum feedback, parameter 205 *Maximum reference*, Ref_{MAX} /414 *Maximum feedback*, FB_{MAX} . See *Reference handling* or *Feedback handling*.

Description of choice:

Set the required voltage value.
 For reasons of accuracy, voltage losses in long signal lines can be compensated for.

311 Terminal 54, analog input voltage
(AI [V] 54 FUNCT.)
Value:

See description of parameter 308. ★ No operation

Function:

This parameter chooses between the different functions available for the input, terminal 54. Scaling of the input signal is done in parameter 312 *Terminal 54, min. scaling* and in parameter 313 *Terminal 54, max. scaling*.

Description of choice:

See description of parameter 308.

For reasons of accuracy, voltage losses in long signal lines should be compensated for.

312 Terminal 54, min. scaling
(AI 54 SCALE LOW)
Value:

 0.0 - 10.0 V ★ 0.0 V
Function:

This parameter is used for setting the signal value that corresponds to the minimum reference value or the minimum feedback, parameter 204 *Minimum reference*, Ref_{MIN} /413 *Minimum feedback*, FB_{MIN} . See *Reference handling* or *Feedback handling*.

Description of choice:

Set the required voltage value.
 For reasons of accuracy, voltage losses in long signal lines can be compensated for.
 If the time-out function is to be applied (parameters 317 *Time out* and 318 *Function after time out*), the value must be set to > 1 V.

313 Terminal 54, max. scaling
(AI 54 SCALE HIGH)
Value:

 0.0 - 10.0 V ★ 10.0 V
Function:

This parameter is used for setting the signal value that corresponds to the maximum reference value or the maximum feedback, parameter 204 *Minimum reference*, Ref_{MIN} /414 *Maximum feedback*, FB_{MAX} . See *Reference handling* or *Feedback handling*.

Description of choice:

Set the required voltage value.
 For reasons of accuracy, voltage losses in long signal lines can be compensated for.

314 Terminal 60, analog input current
(AI [MA] 60 FUNCT.)
Value:

See description of parameter 308. ★ Reference

Function:

This parameter allows a choice between the different functions available for the input, terminal 60. Scaling of the input signal is done in parameter

★ = factory setting. () = display text [] = value for use in communication via serial communication port

315 *Terminal 60, min. scaling* and in parameter
316 *Terminal 60, max. scaling*.

315 Terminal 60, min. scaling

(AI 60 SCALE LOW)

Value:

0.0 - 20.0 mA ★ 4.0 mA

Function:

This parameter determines the signal value that corresponds to the minimum reference or the minimum feedback, parameter 204 *Minimum reference*, $Ref_{MIN}/413$ *Minimum feedback*, FB_{MIN} . See *Reference handling* or *Feedback handling*.

Description of choice:

Set the required current value.
The time-out function is to be used (parameters 317 *Time out* and 318 *Function after time out*), the value must be set to > 2 mA.

316 Terminal 60, max. scaling

(AI 60 SCALE HIGH)

Value:

0.0 - 20.0 mA ★ 20.0 mA

Function:

This parameter determines the signal value that corresponds to the maximum reference value, parameter 205 *Maximum reference value*, Ref_{MAX} . See *Reference handling* or *Feedback handling*.

Description of choice:

Set the desired current value.

317 Time out

(LIVE ZERO TIME)

Value:

1 - 99 sec. ★ 10 sec.

Function:

If the signal value of the reference or feedback signal connected to one of the input terminals 53, 54 or 60 drops to below 50% of the minimum scaling during a period longer than the preset time, the function selected in parameter 318 *Function after time out* will be activated.

This function will only be active if, in parameter 309 or 312, a value has been selected for *terminals 53 and 54, min. scaling* that exceeds 1 V, or if, in

★ = factory setting. () = display text [] = value for use in communication via serial communication port

parameter 315 *Terminal 60, min. scaling*, a value has been selected that exceeds 2 mA.

Description of choice:

Set the desired time.

318 Function after time out

(LIVE ZERO FUNCT.)

Value:

★Off (NO FUNCTION) [0]
Freeze output frequency (FREEZE OUTPUT FREQ.) [1]
Stop (STOP) [2]
Jog (JOG FREQUENCY) [3]
Max. output frequency (MAX FREQUENCY) [4]
Stop and trip (STOP AND TRIP) [5]

Function:

This is where to select the function to be activated after the end of the time-out period (parameter 317 *Time out*).

If a time-out function occurs at the same time as a bus time-out function (parameter 556 *Bus time interval function*), the time-out function in parameter 318 will be activated.

Description of choice:

The output frequency of the frequency converter can be:

- frozen at the present value [1]
- overruled to stop [2]
- overruled to jog frequency [3]
- overruled to max. output frequency [4]
- overruled to stop with subsequent trip [5].

■ Analogue/digital outputs

The two analogue/digital outputs (terminals 42 and 45) can be programmed to show the present status or a process value such as 0 - f_{MAX} .

If the frequency converter is used as a digital output, it gives the present status by means of 0 or 24 V DC.

If the analogue output is used for giving a process value, there is a choice of three types of output signals: 0-20 mA, 4-20 mA or 0-32000 pulses

(depending on the value set in parameter 322 *Terminal 45, output, pulse scaling*. If the output is used as a voltage output (0-10 V), a pull-down resistor of 470 Ω (max. 500 Ω) should be fitted to terminal 39 (common for analogue/digital outputs). If the output is used as a current output, the resulting impedance of the connected equipment should not exceed 500 Ω .

Outputs	terminal no.	42	45
	parameter	319	321
Value:			
No function (NO FUNCTION)		[0]	[0]
Drive ready (READY)		[1]	[1]
Standby (ENABLED & NO WARNING)		[2]	[2]
Running (RUNNING)		[3]	[3]
Running at ref. value (RUNNING AT REFERENCE)		[4]	[4]
Running, no warning (RUNNING NO WARNING)		[5]	[5]
Local reference active (DRIVE IN LOCAL REF.)		[6]	[6]
Remote references active (DRIVE IN REMOTE REF.)		[7]	[7]
Alarm (ALARM)		[8]	[8]
Alarm or warning (ALARM OR WARNING)		[9]	[9]
No alarm (NO ALARM)		[10]	[10]
Current limit (CURRENT LIMIT)		[11]	[11]
Safety interlock (SAFETY INTERLOCK)		[12]	[12]
Start command active (START SIGNAL APPLIED)		[13]	[13]
Reversing (REVERSE OPERATION)		[14]	[14]
Thermal warning (THERMAL WARNING)		[15]	[15]
Hand mode active (DRIVE IN HAND MODE)		[16]	[16]
Auto mode active (DRIVE IN AUTO MODE)		[17]	[17]
Sleep mode (SLEEP MODE)		[18]	[18]
Output frequency lower than f_{LOW} parameter 223 (F OUT < F LOW)		[19]	[19]
Output frequency higher than f_{HIGH} parameter 224 (F OUT > F HIGH)		[20]	[20]
Out of frequency range (FREQ. RANGE WARN.)		[21]	[21]
Output current lower than I_{LOW} parameter 221 (I OUT < I LOW)		[22]	[22]
Output current higher than I_{HIGH} parameter 222 (I OUT > I HIGH)		[23]	[23]
Out of current range (CURRENT RANGE WARN)		[24]	[24]
Out of feedback range (FEEDBACK RANGE WARN.)		[25]	[25]
Out of reference range (REFERENCE RANGE WARN)		[26]	[26]
Relay 123 (RELAY 123)		[27]	[27]
Mains imbalance (MAINS IMBALANCE)		[28]	[28]
Output frequency, 0 - $f_{MAX} \Rightarrow$ 0-20 mA (OUT. FREQ. 0-20 mA)		[29]	[29]
Output frequency, 0 - $f_{MAX} \Rightarrow$ 4-20 mA (OUT. FREQ. 4-20 mA)		[30]	★[30]
Output frequency (pulse sequence), 0 - $f_{MAX} \Rightarrow$ 0-32000 p (OUT. FREQ. PULSE)		[31]	[31]
External reference, Ref_{MIN} - $Ref_{MAX} \Rightarrow$ 0-20 mA (EXT. REF. 0-20 mA)		[32]	[32]
External reference, Ref_{MIN} - $Ref_{MAX} \Rightarrow$ 4-20 mA (EXTERNAL REF. 4-20 mA)		[33]	[33]
External reference (pulse sequence), Ref_{MIN} - $Ref_{MAX} \Rightarrow$ 0-32000 p (EXTERNAL REF. PULSE)		[34]	[34]
Feedback, FB_{MIN} - $FB_{MAX} \Rightarrow$ 0-20 mA (FEEDBACK 0-20 mA)		[35]	[35]
Feedback, FB_{MIN} - $FB_{MAX} \Rightarrow$ 4-20 mA (FEEDBACK 4-20 mA)		[36]	[36]
Feedback (pulse sequence), FB_{MIN} - $FB_{MAX} \Rightarrow$ 0 - 32000 p (FEEDBACK PULSE)		[37]	[37]
Output current, 0 - $I_{MAX} \Rightarrow$ 0-20 mA (MOTOR CUR. 0- 20 mA)		[38]	[38]
Output current, 0 - $I_{MAX} \Rightarrow$ 4-20 mA (MOTOR CUR. 4- 20 mA)		★[39]	[39]
Output current (pulse sequence), 0 - $I_{MAX} \Rightarrow$ 0 - 32000 p (MOTOR CUR. PULSE)		[40]	[40]
Output power, 0 - $P_{NOM} \Rightarrow$ 0-20 mA (MOTOR POWER 0-20 mA)		[41]	[41]
Output power, 0 - $P_{NOM} \Rightarrow$ 4-20 mA (MOTOR POWER 4-20 mA)		[42]	[42]
Output power (pulse sequence), 0 - $P_{NOM} \Rightarrow$ 0- 32000 p (MOTOR POWER PULSE)		[43]	[43]
Bus control, 0.0-100.0% \Rightarrow 0-20 mA (BUS CONTROL 0-20 MA)		[44]	[44]
Bus control, 0.0-100.0% \Rightarrow 4-20 mA (BUS CONTROL 4-20 MA)		[45]	[45]
Bus control (pulse sequence), 0.0-100.0% \Rightarrow 0 - 32.000 Pulses (BUS CONTROL PULS)		[46]	[46]
Motor alteration (MOTOR ALTERATION)		[50]	[50]

Function:

This output can act both as a digital or an analog output. If used as a digital output (data value [0]-[59]),

a 0/24 V DC signal is transmitted; if used as an analogue output, either a 0-20 mA signal, a 4-20 mA signal or a pulse sequence of 0-32000 pulses is transmitted.

★ = factory setting. () = display text [] = value for use in communication via serial communication port

Description of choice:

No function Selected if the frequency converter is not to react to signals.

Drive ready The frequency converter control card receives a supply voltage and the frequency converter is ready for operation.

Stand by The frequency converter is ready for operation, but no start command has been given. No warning.

Running Is active when there is a start command or the output frequency is above 0.1 Hz.

Running at ref. value Speed according to reference.

Running, no warning A start command has been given. No warning.

Local reference active The output is active when the motor is controlled by means of the local reference via the control unit.

Remote references active The output is active when the frequency converter is controlled by means of the remote references.

Alarm The output is activated by an alarm.

Alarm or warning The output is activated by an alarm or a warning.

No alarm The output is active when there is no alarm.

Current limit The output current is greater than the value programmed in parameter 215 *Current limit* I_{LIM} .

Safety interlock The output is active when terminal 27 is a logic '1' and Safety interlock has been selected on the input.

Start command active A start command has been given.

Reversing There is 24 V DC on the output when the motor rotates counter-clockwise. When the motor rotates clockwise, the value is 0 V DC.

Thermal warning The temperature limit in either the motor, the frequency converter or a thermistor connected to an analogue input has been exceeded.

Hand mode active The output is active when the frequency converter is in Hand mode.

Auto mode active The output is active when the frequency converter is in Auto mode.

Sleep mode Active when the frequency converter is in Sleep mode.

Output frequency lower than f_{LOW} The output frequency is lower than the value set in parameter 223 *Warning: Low frequency, f_{LOW}* .

Output frequency higher than f_{HIGH} The output frequency is higher than the value set in parameter 224 *Warning: High frequency, f_{HIGH}* .

Out of frequency range The output frequency is outside the frequency range programmed in parameter 223 *Warning: Low frequency, f_{LOW}* and 224 *Warning: High frequency, f_{HIGH}* .

Output current lower I_{LOW} The output current is lower than the value set in parameter 221 *Warning: Low current, I_{LOW}* .

Output current higher than I_{HIGH} The output current is higher than the value set in parameter 222 *Warning: High current, I_{HIGH}* .

Out of current range The output current is outside the range programmed in parameter 221 *Warning: Low current, I_{LOW}* and 222 *Warning: High current, I_{HIGH}* .

Out of feedback range The feedback signal is outside the range programmed in parameter 227 *Warning: Low feedback, FB_{LOW}* and 228 *Warning: High feedback, FB_{HIGH}* .

Out of reference range The reference lies outside the range programmed in parameter 225 *Warning: Low reference, Ref_{LOW}* and 226 *Warning: High reference, Ref_{HIGH}* .

Relay 123 This function is only used when a profibus option card is installed.

Mains imbalance This output is activated at too high mains imbalance or when a phase is missing in the mains supply. Check the mains voltage to the frequency converter.

0- f_{MAX} \Rightarrow 0-20 mA and

0- f_{MAX} \Rightarrow 4-20 mA and

0- f_{MAX} \Rightarrow 0-32000 p, which generates an output signal proportional to the output frequency in the interval 0 - f_{MAX} (parameter 202 *Output frequency, high limit, f_{MAX}*).

External Ref_{MIN} - Ref_{MAX} \Rightarrow 0-20 mA and

External Ref_{MIN} - Ref_{MAX} \Rightarrow 4-20 mA and

External Ref_{MIN} - Ref_{MAX} \Rightarrow 0-32000 p which generates an output signal proportional to the

★ = factory setting. () = display text [] = value for use in communication via serial communication port

resulting reference value in the interval *Minimum reference*, Ref_{MIN} - *Maximum reference*, Ref_{MAX} (parameters 204/205).

$FB_{MIN}-FB_{MAX} \Rightarrow 0-20 \text{ mA}$ and
 $FB_{MIN}-FB_{MAX} \Rightarrow 4-20 \text{ mA}$ and
 $FB_{MIN}-FB_{MAX} \Rightarrow 0-32000 \text{ p}$ an output signal proportional to the reference value in the interval *Minimum feedback*, FB_{MIN} - *Maximum feedback*, FB_{MAX} (parameters 413/414) is obtained.

$0 - I_{VLT,MAX} \Rightarrow 0-20 \text{ mA}$ and
 $0 - I_{VLT,MAX} \Rightarrow 4-20 \text{ mA}$ and
 $0 - I_{VLT,MAX} \Rightarrow 0-32000 \text{ p}$, an output signal proportional to the output current in the interval $0 - I_{VLT,MAX}$ is obtained.

$0 - p_{NOM} \Rightarrow 0-20 \text{ mA}$ and
 $0 - p_{NOM} \Rightarrow 4-20 \text{ mA}$ and
 $0 - p_{NOM} \Rightarrow 0-32000 \text{ p}$, which generates an output signal proportional to the present output power. 20 mA corresponds to the value set in parameter 102 *Motor power*, $P_{M,N}$.

$0.0 - 100.0\% \Rightarrow 0 - 20 \text{ mA}$ and

$0.0 - 100.0\% \Rightarrow 4 - 20 \text{ mA}$ and

$0.0 - 100.0\% \Rightarrow 0 - 32.000$ pulses which generates an output signal proportional to the value (0.0-100.0%) received by serial communication. Writing from Serial communication is done to parameter 364 (terminal 42) and 365 (terminal 45). This function is limited to the following protocols: FC bus, Profibus, LonWorks FTP, DeviceNet, and Modbus RTU.

Motor alternation A relay or digital output can be used in conjunction with output contactors to alternate the frequency converter's output between motors based on an internal timer. See parameters 433 and 434 for further information and programming information.

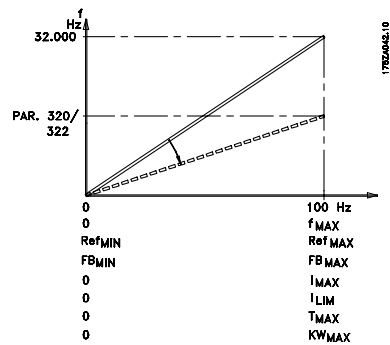

**321 Terminal 45, output
(AO 45 FUNCTION)**

Value:

See description of parameter 319 *Terminal 42, Output*.

Function:

This output can function both as a digital or an analog output. When used as a digital output (data value [0]-[26]) it generates a 24 V (max. 40 mA) signal. For the analog outputs (data value [27] - [41]) there is a choice of 0-20 mA, 4-20 mA or a pulse sequence.

Description of choice:

See description of parameter 319 *Terminal 42, Output*.

**322 Terminal 45, output, pulse scaling
(AO 45 PULS SCALE)**

Value:

1 - 32000 Hz ★ 5000 Hz

Function:

This parameter allows scaling of the pulse output signal.

Description of choice:

Set the desired value.

**320 Terminal 42, output, pulse scaling
(AO 42 PULS SCALE)**

Value:

1 - 32000 Hz ★ 5000 Hz

Function:

This parameter allows scaling of the pulse output signal.

Description of choice:

Set the desired value.

★ = factory setting. () = display text [] = value for use in communication via serial communication port

■ Relay outputs

Relay outputs Relay outputs 1 and 2 can be used to give the present status or a warning.

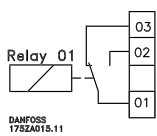

Relay 1
1 - 3 break, 1 - 2 make
Max. 240 V AC, 2 Amp.
The relay is placed with
mains and motor terminals.

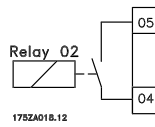

Relay 2
4 - 5 make
Max. 50 V AC, 1 A, 60 VA.
Max. 75 V DC, 1 A 30 W.
The relay is placed on the control card, see
Electrical installation, control cables.

Relay Outputs	terminal no.	1	2
	parameter	323	326
Value:			
No function (NO FUNCTION)		[0]	[0]
Ready signal (READY)		[1]	[1]
Standby (STAND BY)		[2]	[2]
Running (RUNNING)		[3]	★[3]
Running at ref. value (RUNNING AT REFERENCE)		[4]	[4]
Running, no warning (RUNNING NO WARNING)		[5]	[5]
Local reference active (DRIVE IN LOCAL REF)		[6]	[6]
Remote references active (DRIVE IN REMOTE REF.)		[7]	[7]
Alarm (ALARM)		[8]	[8]
Alarm or warning (ALARM OR WARNING)		[9]	[9]
No alarm (NO ALARM)		★[10]	[10]
Current limit (CURRENT LIMIT)		[11]	[11]
Safety interlock (SAFETY INTERLOCK)		[12]	[12]
Start command active (START SIGNAL APPLIED)		[13]	[13]
Reversing (RUNNING IN REVERSE)		[14]	[14]
Thermal warning (THERMAL WARNING)		[15]	[15]
Hand mode active (DRIVE IN HAND MODE)		[16]	[16]
Auto mode active (DRIVE IN AUTO MODE)		[17]	[17]
Sleep mode (SLEEP MODE)		[18]	[18]
Output frequency lower than f_{LOW} parameter 223 (F OUT < F LOW)		[19]	[19]
Output frequency higher than f_{HIGH} parameter 224 (F OUT > F HIGH)		[20]	[20]
Out of frequency range (FREQ RANGE WARN.)		[21]	[21]
Output current lower than I_{LOW} parameter 221 (I OUT < I LOW)		[22]	[22]
Output current higher than I_{HIGH} parameter 222 (I OUT > I HIGH)		[23]	[23]
Out of current range (CURRENT RANGE WARN.)		[24]	[24]
Out of feedback range (FEEDBACK RANGE WARN.)		[25]	[25]
Out of reference range (REFERENCE RANGE WARN.)		[26]	[26]
Relay 123 (RELAY 123)		[27]	[27]
Mains imbalance (MAINS IMBALANCE)		[28]	[28]
Control word 11/12 (CONTROL WORD 11/12)		[29]	[29]
Motor alteration (MOTOR ALTERATION)		[30]	[30]

Function:

Description of choice:

See description of [0] - [28] in *Analog/digital outputs*.

Control word bit 11/12. Relay 1 and relay 2 can be activated via the serial communication. Bit 11 activates relay 1 and bit 12 activates relay 2.

If the parameter 556 *Bus time interval function* becomes active, relay 1 and relay 2 will become cut off if they are activated via the serial communication.

Motor Alteration. The output is controlled by a timer to activate alternate available run time between multiple motors.

★ = factory setting. () = display text [] = value for use in communication via serial communication port

323 Relay 1, output function
(RELAY1 FUNCTION)
Function:

This output activates a relay switch. Relay switch 01 can be used for indicating status and warnings. The relay is activated when the conditions for the relevant data values have been fulfilled.

Activation/deactivation can be programmed in parameter 324 *Relay 1, ON delay* and parameter 325 *Relay 1, OFF delay*.

See *General technical data*.

Description of choice:

See data choice and connections in *Relay outputs*.

324 Relay 01, ON delay
(RELAY1 ON DELAY)
Value:

0 - 600 sec. ★ 0 sec.

Function:

This parameter allows a delay of the cut-in time of relay 1 (terminals 1-2).

Description of choice:

Enter the desired value.

325 Relay 01, OFF delay
(RELAY1 OFF DELAY)
Value:

0 - 600 sec. ★ 2 sec.

Function:

This parameter makes it possible to delay the cut-out time of relay 01 (terminals 1-2).

Description of choice:

Enter the desired value.

326 Relay 2, output function
(RELAY2 FUNCTION)
Value:

See functions of relay 2 on previous page.

Function:

This output activates a relay switch. Relay switch 2 can be used for indicating status and warnings. The relay is activated when the conditions for the relevant data values have been fulfilled.

See *General technical data*.

★ = factory setting. () = display text [] = value for use in communication via serial communication port

Description of choice:

See data choice and connections in *Relay outputs*.

327 Pulse reference, max. frequency
(PULSE REF. MAX)
Value:

100 - 65000 Hz at terminal 29 ★ 5000 Hz
100 - 5000 Hz at terminal 17

Function:

This parameter is used to set the pulse value that must correspond to the maximum reference, parameter 205 *Maximum reference, Ref_{MAX}*.

The pulse reference signal can be connected via terminal 17 or 29.

Description of choice:

Set the required maximum pulse reference.

328 Pulse feedback, max. frequency
(PULSE FDBK MAX.)
Value:

100 - 65000 Hz at terminal 33 ★ 25000 Hz

Function:

This is where the pulse value that must correspond to the maximum feedback value is set. The pulse feedback signal is connected via terminal 33.

Description of choice:

Set the desired feedback value.

364 Terminal 42, bus control**(CONTROL OUTPUT 42)****365 Terminal 45, bus control****(CONTROL OUTPUT 45)****Value:**

0.0 - 100 %

★ 0

Function:

Through serial communication, a value between 0.1 and 100.0 is written to the parameter.

The parameter is hidden and cannot be seen from the LCP.

■ Application functions 400-434

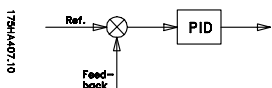

Includes this parameter group, the special functions of the frequency converter PID regulation, setting of the feedback range and the Setup of the Sleep mode function. Additionally, this parameter group includes:

- Reset function.
- Flying start.
- Option of interference reduction method.
- Setup of any function upon loss of load, e.g. because of a damaged V-belt.
- Setting of switching frequency.
- Selection of process units.

400 Reset function (RESET FUNCTION)

Value:

★ Manual reset (MANUAL RESET)	[0]
Automatic reset x 1 (AUTOMATIC X 1)	[1]
Automatic reset x 2 (AUTOMATIC X 2)	[2]
Automatic reset x 3 (AUTOMATIC X 3)	[3]
Automatic reset x 4 (AUTOMATIC X 4)	[4]
Automatic reset x 5 (AUTOMATIC X 5)	[5]
Automatic reset x 10 (AUTOMATIC X 10)	[6]
Automatic reset x 15 (AUTOMATIC X 15)	[7]
Automatic reset x 20 (AUTOMATIC X 20)	[8]
Infinite automatic reset (INFINITE AUTOMATIC)	[9]

Function:

This parameter allows a choice of whether to reset and restart manually after a trip, or whether the frequency converter is to be reset and restarted automatically. In addition, there is a choice of the number of times the unit is to attempt a restart. The time between each reset attempt is set in parameter 401 *Automatic restart time*.

Description of choice:

If *Manual reset* [0] is selected, resetting must be effected via the "Reset" key or via a digital input. If the frequency converter is to carry out an automatic reset and restart after a trip, select data value [1]-[9].



The motor may start without warning.

401 Automatic restart time (AUTORESTART TIME)

Value:

0 - 600 sec.

★ 10 sec.

Function:

This parameter allows setting of the time from tripping until the automatic reset function begins. It is assumed that automatic reset has been selected in parameter 400 *Reset* function.

Description of choice:

Set the desired time.

402 Flying start (FLYING START)

Value:

★ Disable (DISABLE)	[0]
Enable (ENABLE)	[1]
DC brake and start (DC BRAKE AND START)	[3]

Function:

This function makes it possible for the frequency converter to "catch" a spinning motor, which - e.g. because of a mains failure - is no longer controlled by the frequency converter. This function is activated whenever a start command is active.

For the VLT frequency converter to be able to "catch" the spinning motor, the motor speed must be lower than the frequency that corresponds to the frequency in parameter 202 *Output frequency high limit, f_{MAX}*.

Description of choice:

Select *Disable* [0] if this function is not required. Select *Enable*[1] if the VLT frequency converter is to be able to "catch" and control a spinning motor. Select *DC brake and start* [2] if the VLT frequency converter is to brake the motor with DC braking, and then restart the motor. It is assumed that parameters 114-116 *DC braking* are enabled. In the case of a substantial "windmilling" effect (spinning motor), the VLT frequency converter will not "catch" a spinning motor unless *DC brake and start* has been selected.

★ = factory setting. () = display text [] = value for use in communication via serial communication port

■ Sleep mode

Sleep mode makes it possible to stop the motor when it is running at low speed, similar to a no load situation. If consumption in the system goes back up, the frequency converter will start the motor and supply the power required.



NB!:

Energy can be saved with this function, since the motor is only in operation when the system needs it.

Sleep mode is not active if *Local reference* or *Jog* has been selected

The function is active in both *Open loop* and *Closed loop*.

In parameter 403 *Sleep mode timer*, the Sleep mode is activated. In parameter 403 *Sleep mode timer*, a timer is set that determines how long the output frequency can be lower than the frequency set in parameter 404 *Sleep frequency*. When the timer runs out, the frequency converter will ramp down the motor to stop via parameter 207 *Ramp-down time*. If the output frequency rises above the frequency set in parameter 404 *Sleep frequency*, the timer is reset.

While the frequency converter has stopped the motor in sleep mode, a theoretical output frequency is calculated on the basis of the reference signal. When the theoretical output frequency rises above the frequency in parameter 405 *Wake up frequency*, the frequency converter will restart the motor and the output frequency will ramp up to the reference.

In systems with constant pressure regulation, it is advantageous to provide extra pressure to the system before the frequency converter stops the motor. This extends the time during which the frequency converter has stopped the motor and helps to avoid frequent starting and stopping of the motor, e.g. in the case of system leaks.

If 25% more pressure is required before the frequency converter stops the motor, parameter 406 *Boost setpoint* is set to 125%.

Parameter 406 *Boost setpoint* is only active in *Closed loop*.



NB!:

In highly dynamic pumping processes, it is recommended to switch off the *Flying Start* function (parameter 402).

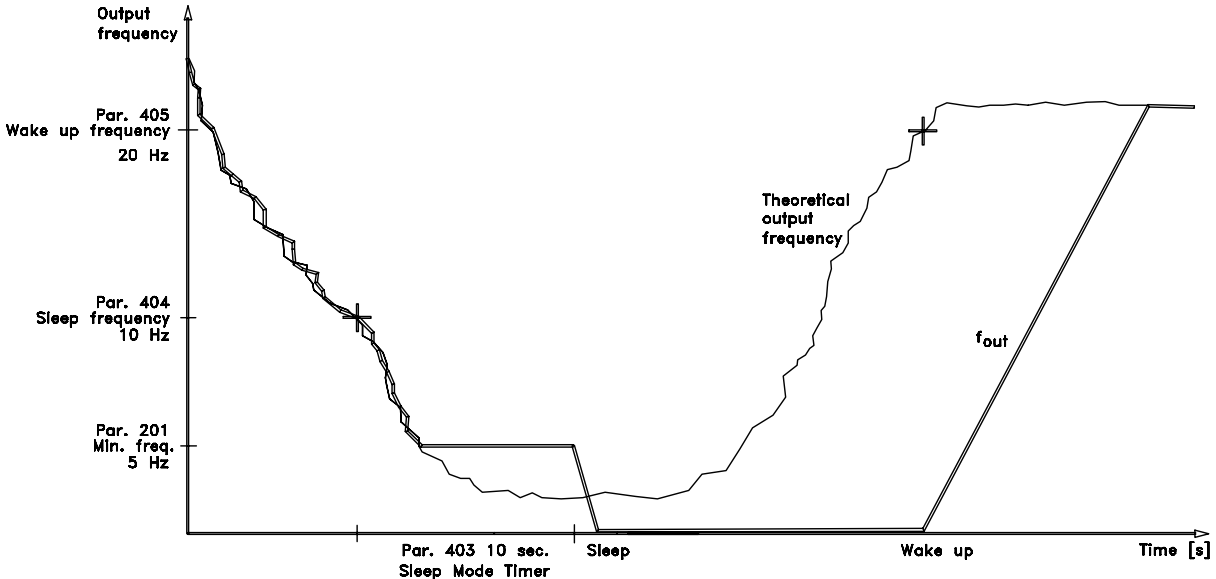

175H4346.14

Programming

★ = factory setting. () = display text [] = value for use in communication via serial communication port

403 Sleep mode timer

(SLEEP MODE TIMER)

Value:

0 - 300 sec.(OFF) ★ OFF

Function:

This parameter enables the frequency converter to stop the motor if the load on the motor is minimal. The timer in parameter 403 *Sleep mode timer* starts when the output frequency drops below the frequency set in parameter 404 *Sleep frequency*. When the time set in the timer has expired, the frequency converter will turn off the motor. The frequency converter will restart the motor, when the theoretical output frequency exceeds the frequency in parameter 405 *Wake up frequency*.

Description of choice:

Select OFF if this function is not wanted. Set the threshold value that is to activate Sleep mode after the output frequency has fallen below parameter 404 *Sleep frequency*.

404 Sleep frequency

(SLEEP FREQUENCY)

Value:

000,0 - par. 405 *Wake up frequency* ★ 0.0 Hz

Function:

When the output frequency falls below the preset value, the timer will start the time count set in parameter 403 *Sleep mode*. The present output frequency will follow the theoretical output frequency until f_{MIN} is reached.

Description of choice:

Set the required frequency.

405 Wake up frequency

(WAKEUP FREQUENCY)

Value:

Par 404 *Sleep frequency* - par. 202 f_{MAX} ★ 50 Hz

Function:

When the theoretical output frequency exceeds the preset value, the frequency converter restarts the motor.

Description of choice:

Set the required frequency.

406 Boost setpoint

(BOOST SETPOINT)

Value:

1 - 200 % ★ 100 % of setpoint

Function:

This function can only be used if *Closed loop* has been selected in parameter 100. In systems with constant pressure regulation, it is advantageous to increase the pressure in the system before the frequency converter stops the motor. This extends the time during which the frequency converter stops the motor and helps to avoid frequent starting and stopping of the motor, e.g. in the case of leaks in the water supply system.

Description of choice:

Set the required *Boost setpoint* as a percentage of the resulting reference under normal operation. 100% corresponds to the reference without boost (supplement).

407 Switching frequency

(SWITCHING FREQ.)

Value:

Depends on the size of the unit.

Function:

The preset value determines the switching frequency of the inverter, provided *Fixed switching frequency* [1] has been selected in parameter 408 *Interference reduction method*. If the switching frequency is changed, this may help to minimise possible acoustic noise from the motor.



NB!:

The output frequency of the frequency converter can never assume a value higher than 1/10 of the switching frequency.

Description of choice:

When the motor is running, the switching frequency is adjusted in parameter 407 *Switching frequency*, until the frequency has been achieved at which the motor is as quiet as possible.



NB!:

Switching frequencies higher than 4.5 kHz implement automatic derating of the maximum output of the frequency converter. See *Derating of high switching frequency*.

★ = factory setting. () = display text [] = value for use in communication via serial communication port

408 Interference reduction method (NOISE REDUCTION)

Value:

★ASFM (ASFM)	[0]
Fixed switching frequency (FIXED SWITCHING FREQ.)	[1]
LC filter fitted (LC-FILTER CONNECTED)	[2]

Function:

Used to select different methods for reducing the amount of acoustic interference from the motor.

Description of choice:

ASFM [0] guarantees that the maximum switching frequency, determined by parameter 407, is used at all times without derating of the frequency converter. This is done by monitoring the load.

Fixed switching frequency [1] makes it possible to set a fixed high/low switching frequency. This can generate the best result, as the switching frequency can be set to reduce acoustic noise in the motor. The switching frequency is adjusted in parameter 407 *Switching frequency*. *LC-filter fitted* [2] is to be used if an LC-filter is fitted between the frequency converter and the motor, as the frequency converter will otherwise not be able to protect the LC-filter.

Note: *ASFM* has no function for VLT 8052-8402, 525-690 V.

409 Function in case of no load (FUNCT. LOW CURR.)

Value:

Trip (TRIP)	[0]
★Warning (WARNING)	[1]

Function:

This function is activated when the output current goes below parameter 221 *Warning: Low current*.

Description of choice:

In the case of a *Trip* [1], the frequency converter will stop the motor.

If *Warning* [2] is selected, the frequency converter will give a warning if the output current drops below the threshold value in parameter 221 *Warning: Low current, I_{Low}*.

410 Function at mains failure (MAINS FAILURE)

Value:

★Trip (TRIP)	[0]
Autoderate & warning (AUTODERATE & WARNING)	[1]
Warning (WARNING)	[2]

Function:

Select the function which is to be activated if the mains imbalance becomes too high or if a phase is missing.

Description of choice:

At *Trip* [0] the frequency converter will stop the motor within a few seconds (depending on drive size).

If *Autoderate & warning* [1] is selected, the drive will export a warning and reduce the output current to 30 % of $I_{VLT,N}$ to maintain operation.

At *Warning* [2] only a warning will be exported when a mains failure occurs, but in severe cases, other extreme conditions might result in a trip.



NB!:

If *Warning* has been selected, the life expectancy of the drive will be reduced when the mains failure persists.



NB!:

At phase loss the cooling fans cannot be powered and the frequency converter might trip on overheating. This applies to

IP 00/IP 20/Nema 1

- VLT 8042-8062, 200-240 V
- VLT 8152-8600, 380-480 V
- VLT 8052-8402, 525-690 V

IP 54

- VLT 8006-8062, 200-240 V
- VLT 8016-8600, 380-480 V
- VLT 8016-8072, 525-600 V
- VLT 8052-8402, 525-690 V

411 Function at overtemperature (FUNCT. OVERTEMP)

Value:

★Trip (TRIP)	[0]
Autoderate & warning (AUTODERATE & WARNING)	[1]

Function:

Select the function which is to be activated when the frequency converter is exposed to an overtemperature condition.

Description of choice:

At *Trip* [0] the frequency converter will stop the motor and export an alarm.

At *Autoderate & warning* [1] the frequency converter will first reduce the switching frequency to minimize internal losses. If the overtemperature condition persists, the frequency converter will reduce the output current until the heat sink temperature stabilizes. When the function is active, a warning will be exported.

412 Trip delay overcurrent, I_{LIM} ()
(OVERLOAD DELAY)
Value:

0 - 60 sec. (61=OFF) ★ 61 sec. (OFF)

Function:

When the frequency converter registers that the output current has reached the current limit I_{LIM} (parameter 215 *Current limit*) and stays there for the duration selected, a cut-out will be performed.

Description of choice:

Select for how long the frequency converter is to be able to keep up with the output current at the current limit I_{LIM} before it cuts out.

In OFF mode, parameter 412 *Trip delay overcurrent*, I_{LIM} is inactive, i.e. cut-outs are not performed.

■ Feedback signals in open loop

Normally, feedback signals and thus feedback parameters are only used in *Closed loop operation*; in VLT 8000 AQUA units, however, the feedback parameters are also active in *Open loop* operation. In *Open loop mode*, the feedback parameters can be used to show a process value in the display. If the present temperature is to be displayed, the temperature range can be scaled in parameters 413/414 *Minimum/Maximum feedback*, and the unit (°C, °F) in parameter 415 *Process units*.

413 Minimum feedback, FB_{MIN}
(MIN. FEEDBACK)
Value:

-999,999.999 - FB_{MAX} ★ 0.000

Function:

Parameters 413 *Minimum feedback*, FB_{MIN} and 414 *Maximum feedback*, FB_{MAX} are used to scale the display indication, thereby ensuring that

it shows the feedback signal in a process unit proportionally to the signal at the input.

Description of choice:

Set the value to be shown on the display at minimum feedback signal value (par. 309, 312, 315 *Min. scaling*) on the selected feedback input (parameters 308/311/314 *Analog inputs*).

414 Maximum feedback, FB_{MAX}
(MAX. FEEDBACK)
Value:

FB_{MIN} - 999,999.999 ★ 100.000

Function:

See the description of par. 413 *Minimum feedback*, FB_{MIN}.

Description of choice:

Set the value to be shown on the display when maximum feedback (par. 310, 313, 316 *Max. scaling*) has been achieved at the selected feedback input (parameters 308/311/314 *Analog inputs*).

415 Units relating to closed loop
(REF. / FDBK. UNIT)

No unit	[0]	°C	[21]
★%	[1]	GPM	[22]
rpm	[2]	gal/s	[23]
ppm	[3]	gal/min	[24]
pulse/s	[4]	gal/h	[25]
l/s	[5]	lb/s	[26]
l/min	[6]	lb/min	[27]
l/h	[7]	lb/h	[28]
kg/s	[8]	CFM	[29]
kg/min	[9]	ft ³ /s	[30]
kg/h	[10]	ft ³ /min	[31]
m ³ /s	[11]	ft ³ /h	[32]
m ³ /min	[12]	ft/s	[33]
m ³ /h	[13]	in wg	[34]
m/s	[14]	ft wg	[35]
mbar	[15]	PSI	[36]
bar	[16]	lb/in ²	[37]
Pa	[17]	HP	[38]
KPa	[18]	°F	[39]
mWG	[19]		
kW	[20]		

Function:

Selection of unit to be shown on the display. This unit will be used if *Reference [unit]* [2] or *Feedback [unit]* [3] has been selected in one of the parameters 007-010, as well as in the Display mode. In *Closed loop*, the unit is also used as a unit for

★ = factory setting. () = display text [] = value for use in communication via serial communication port

Minimum/Maximum reference and Minimum/ Maximum feedback, as well as Setpoint 1 and Setpoint 2.

Description of choice:

Select the required unit for the reference/feed-back signal.

■ PID for process control

The PID controller maintains a constant process condition (pressure, temperature, flow, etc.) and adjusts motor speed on the basis of a reference/setpoint and the feedback signal.

A transmitter supplies the PID controller with a feedback signal from the process to indicate its actual state. The feedback signal varies with the process load. This means that deviations occur between the reference/setpoint and the actual process state. Such deviations are evened out by the PID regulator, in that it regulates the output frequency up or down in relation to the deviation between the reference/setpoint and the feedback signal.

The integral PID regulator in VLT 8000 AQUA units have been optimised for use in water applications. This means that a number of specialised functions are available in VLT 8000 AQUA units.

Using the VLT 8000 AQUA, there is no need for extra modules to be installed. For example, only one required reference/setpoint and the handling of feedback need to be programmed.

There is a built in option for connecting two feed-back signals to the system.

Correction for voltage losses in long signal cables can be carried out when using a transmitter with a voltage output. This is done in parameter group 300 *Min./Max.scaling*.

Feedback

The feedback signal must be connected to a terminal on the frequency converter. Use the list below to decide which terminal to use and which parameters to program.

Feedback type	Terminal	Parameters
Pulse	33	307
Voltage	53, 54	308, 309, 310 or 311, 312, 313
Current	60	314, 315, 316
Bus feedback 1	68+69	535
Bus feedback 2	68+69	536

Please note that the feedback value in parameter 535/536 Bus feedback 1 and 2 can only be set via serial communication (not via the control unit).

Furthermore, the minimum and maximum feedback (parameters 413 and 414) must be set to a value in the process unit that corresponds to the minimum and maximum scaling value for signals connected to the terminal. The process unit is selected in parameter 415 *Process units*.

Reference

In parameter 205 *Maximum reference*, Ref_{MAX} , a maximum reference that scales the sum of all references, i.e. the resulting reference, can be set. The *minimum reference* in parameter 204 indicates the smallest value that the resulting reference can assume. The reference range cannot exceed the feedback range.

If *Preset references* are required, set these in parameters 211 to 214 *Preset reference*. See *Reference type*.

See also *Reference handling*.

If a current signal is used as a feedback signal, voltage can be used as analog reference. Use the list below to decide which terminal to use and which parameters to program.

Reference type	Terminal	Parameters
Pulse	17 or 29	301 or 305
Voltage	53 or 54	308, 309, 310 or 311, 312, 313
Current	60	314, 315, 316
Preset reference		211, 212, 213, 214
Setpoints		418, 419
Bus reference	68+69	

Please note that the bus reference can only be set via serial communication.



NB!:

Terminals that are not in use may preferably be set to *No function* [0].

Inverse regulation

Normal regulation means that the motor speed increases when the reference/setpoint is higher than the feedback signal. If there is a need for inverse regulation, in which the speed is reduced when the reference/setpoint is higher than the feedback signal, inverse must be programmed in parameter 420 *PID normal/inverse control*.

Anti Windup

The process regulator is factory preset with an active anti-windup function. This function ensures that when either a frequency limit, current limit or voltage limit is reached, the integrator will be initialised for a frequency that corresponds to the present output frequency. This avoids integration on a deviation between the reference/setpoint and the actual state of the process, the controller of which is not possible by means of a speed change. This function can be disabled in parameter 421 *PID anti windup*.

Start-up conditions

In some applications, optimum setting of the process regulator will mean that it takes an excessive time for the required process state to be reached. In such applications it might be an advantage to fix an output frequency to which the frequency converter is to bring the motor before the process regulator is activated. This is done by programming a *PID start-up frequency* in parameter 422.

Differentiator gain limit

If there are very quick variations in a given application with respect to the reference/setpoint signal or the feedback signal, the deviation between reference/setpoint and the actual process state will quickly change. The differentiator may thus become too dominant. This is because it reacts to the deviation between the reference/setpoint and the actual process state. The quicker the deviation changes, the stronger the resulting differentiator frequency contribution. The differentiator frequency contribution can thus be limited to allow the setting of a reasonable differentiation time for slow changes and a suitable frequency contribution for quick changes. This is done in parameter 426, *PID Differentiator gain limit*.

Lowpass filter

If there are ripple currents/voltages on the feedback signal, these can be dampened by means of a built-in lowpass filter. Set a suitable lowpass filter time constant. This time constant represents the limit frequency of the ripples occurring on the feedback signal.

If the lowpass filter has been set to 0.1s, the limit frequency will be 10 RAD/sec., corresponding to $(10 / 2 \times \pi) = 1.6$ Hz. This means that all currents/voltages that vary by more than 1.6 oscillations per second will be removed by the filter.

In other words, regulation will only be carried out on a feedback signal that varies by a frequency of less than 1.6 Hz. Choose a suitable time constant in parameter 427, *PID Lowpass filter time*.

Optimisation of the process regulator

The basic settings have now been made; all that remains to be done is to optimize the proportional gain, the integration time and the differentiation time (parameters 423, 424 and 425). In most processes, this can be done by following the guidelines given below.

1. Start the motor.
2. Set parameter 423 *PID proportional gain* to 0.3 and increase it until the process shows that the feedback signal is unstable. Then reduce the

value until the feedback signal has stabilised. Now lower the proportional gain by 40-60%.

3. Set parameter 424 *PID integration time* to 20 s and reduce the value until the process shows that the feedback signal is unstable. Increase the integration time until the feedback signal stabilizes, followed by an increase of 15-50%.
4. Parameter 425 *PID differentiation time* is only used in very fast-acting systems. The typical value is 1/4 of the value set in parameter 424 *PID Integration time*. The differentiator should only be used when the setting of the proportional gain and the integration time have been fully optimized.



NB!:

If necessary, start/stop can be activated a number of times in order to provoke an unstable feedback signal.

■ PID overview

The block diagram below shows reference and setpoint in relation to the feedback signal.

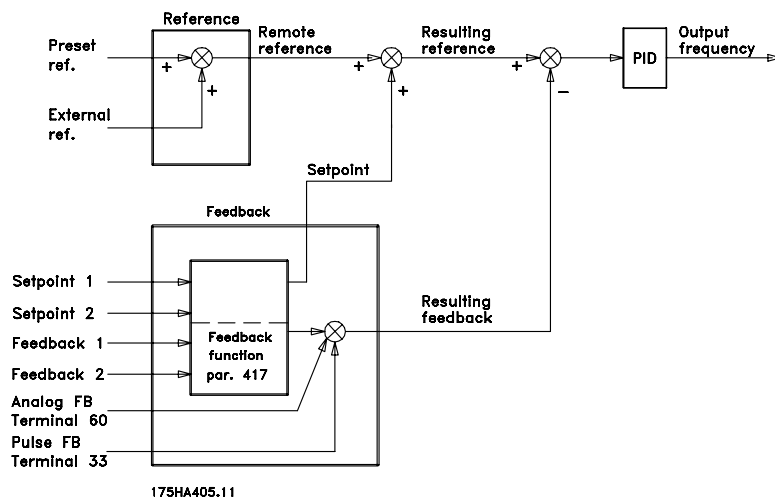

As can be seen, the remote reference is totalled with setpoint 1 or setpoint 2. See also *Reference handling*. Which setpoint is to be totalled with the

remote reference depends on the selection made in parameter 417 *Feedback function*.

■ Feedback handling

The feedback handling can be seen from the block diagram on the next page. The block diagram shows how and by which parameters the feedback handling can be affected. Options as feedback signals are: voltage, current, pulse and bus feedback signals. In zone regulation, feedback signals must be selected as voltage inputs (terminals 53 and 54). Please note that *Feedback 1* consists of bus feedback 1 (parameter 535) totalled with the feedback signal value of terminal 53. *Feedback 2* consists of bus feedback 2 (parameter 536) totalled with the feedback signal value of terminal 54.

In addition, the frequency converter has an integral calculator capable of converting a pressure signal into a "linear flow" feedback signal. This function is activated in parameter 416 *Feedback conversion*.

The parameters for feedback handling are active both in closed and open loop modes. In *open loop*, the present temperature can be displayed by connecting a temperature transmitter to a feedback input.

In a closed loop, there are - roughly speaking - three possibilities of using the integral PID regulator and set-point/ feedback handling:

1. 1 setpoint and 1 feedback
2. 1 setpoint and 2 feedbacks

3. 2 Setpoints and 2 feedbacks

★ = factory setting. () = display text [] = value for use in communication via serial communication port

1 setpoint and 1 feedback

If only 1 setpoint and 1 feedback signal are used, parameter 418 *Setpoint 1* will be added to the remote reference. The sum of the remote reference and *Setpoint 1* becomes the resulting reference, which will then be compared with the feedback signal.

1 setpoint and 2 feedbacks

Just like in the above situation, the remote reference is added to *Setpoint 1* in parameter 418. Depending

on the feedback function selected in parameter 417 *Feedback function*, a calculation will be made of the feedback signal with which the sum of the references and the setpoint is to be compared. A description of the individual feedback functions is given in parameter 417 *Feedback function*.

2 Setpoints and 2 feedbacks

Used in 2-zone regulation, where the function selected in parameter 417 *Feedback function* calculates the setpoint to be added to the remote reference.

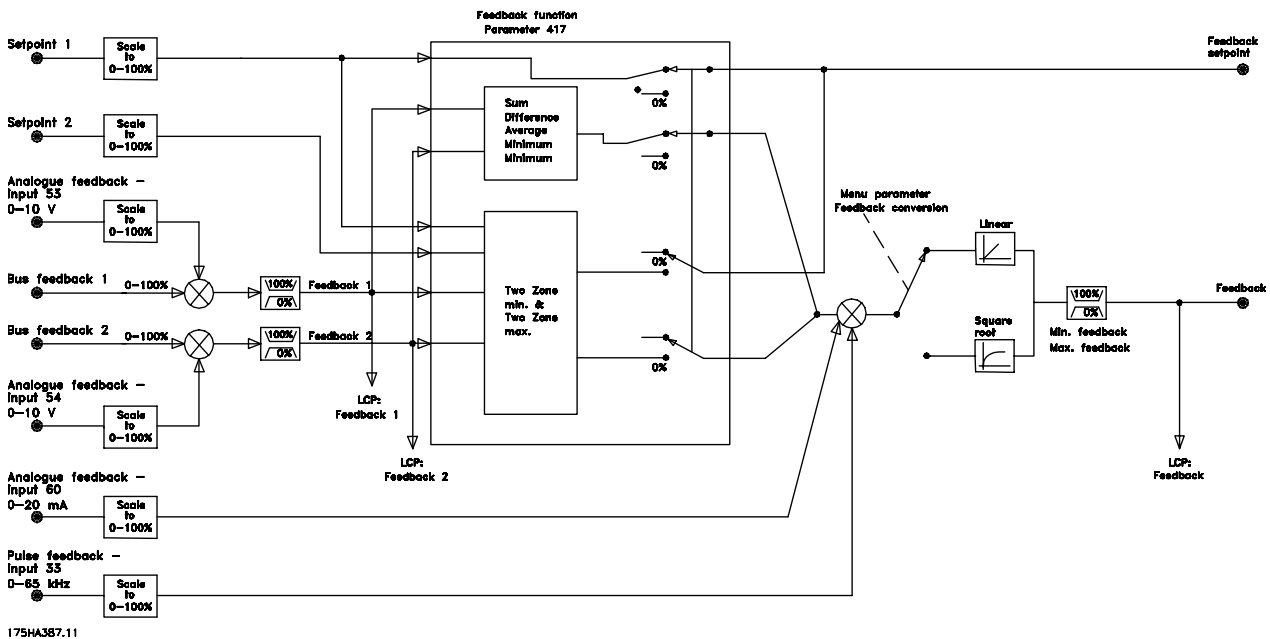

175HA387.11

416 Feedback conversion (FEEDBACK CONV.)

- Value:**
- ★Linear (LINEAR) [0]
 - Square root (SQUARE ROOT) [1]

Function:

In this parameter, a function is selected which converts a connected feedback signal from the process to a feedback value that equals the square root of the connected signal. This is used, e.g. where regulation of a flow (volume) is required on the basis of pressure as feedback signal (flow = constant x $\sqrt{\text{pressure}}$). This conversion makes it possible to set the reference in such a way that there is a linear connection between the reference and the flow required. See drawing in next column. Feedback conversion should not be used if 2-zone regulation in parameter 417 *Feedback function* has been selected.

Description of choice:

If *Linear* [0] is selected, the feedback signal and the feedback value will be proportional. If *Square root* [1] is selected, the frequency converter translates the feedback signal to a square root value.

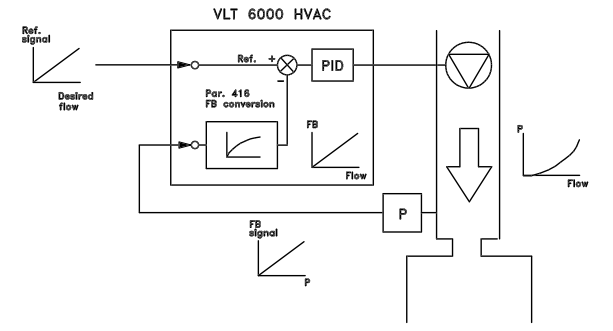

417 Feedback function (2 FEEDBACK, CALC.)

- Value:**
- Minimum (MINIMUM) [0]
 - ★Maximum (MAXIMUM) [1]

★ = factory setting. () = display text [] = value for use in communication via serial communication port

Sum (SUM)	[2]
Difference (DIFFERENCE)	[3]
Average (AVERAGE)	[4]
2-zone minimum (2 ZONE MIN)	[5]
2-zone maximum (2 ZONE MAX)	[6]
Feedback 1 only (FEEDBACK 1 ONLY)	[7]
Feedback 2 only (FEEDBACK 2 ONLY)	[8]

Function:

This parameter allows a choice between different calculation methods whenever two feedback signals are used.

Description of choice:

If *Minimum* [0] is selected, the frequency converter will compare *feedback 1* with *feedback 2* and regulate on the basis of the lower feedback value.

Feedback 1 = Sum of parameter 535 *Bus feedback 1* and the feedback signal value of terminal 53.

Feedback 2 = Sum of parameter 536 *Bus feedback 2* and the feedback signal value of terminal 54.

If *Maximum* [1] is selected, the frequency converter will compare *feedback 1* with *feedback 2* and regulate on the basis of the higher feedback value.

If *Sum* [2] is selected, the frequency converter will total *feedback 1* with *feedback 2*. Please note that the remote reference will be added to Setpoint 1.

If *Difference* [3] is selected, the frequency converter will subtract *feedback 1* from *feedback 2*.

If *Average* [4] is selected, the frequency converter will calculate the average of *feedback 1* and *feedback 2*. Please note that the remote reference will be added to the Setpoint 1.

If *2-zone minimum* [5] is selected, the frequency converter will calculate the difference between *Setpoint 1* and *feedback 1* as well as *Setpoint 2* and *feedback 2*. After this calculation, the frequency converter will use the larger difference. A positive difference, i.e. a setpoint higher than the feedback, is always larger than a negative difference.

If the difference between *Setpoint 1* and *feedback 1* is the larger of the two, parameter 418 *Setpoint 1* will be added to the remote reference.

If the difference between *Setpoint 2* and *feedback 2* is the larger of the two, the remote reference will be added to the parameter 419 *Setpoint 2*.

If *2-zone maximum* [6] is selected, the frequency converter will calculate the difference between *Setpoint 1* and *feedback 1* as well as *Setpoint 2* and *feedback 2*. After the calculation, the frequency converter will use the smaller difference. A negative difference, i.e.

one where the setpoint is lower than the feedback, is always smaller than a positive difference.

If the difference between *Setpoint 1* and *feedback 1* is the smaller of the two, the remote reference will be added to the parameter 418 *Setpoint 1*.

If the difference between *Setpoint 2* and *feedback 2* is the smaller of the two, the remote reference will be added to parameter 419 *Setpoint 2*.

If *Feedback 1 only* is selected, terminal 53 is read as the feedback signal and terminal 54 is ignored. The feedback from terminal 53 is directly associated with Setpoint 1.

If *Feedback 2 only* is selected, terminal 54 is read as the feedback signal and terminal 53 is ignored. The feedback from terminal 54 is directly associated with Setpoint 2.

418 Setpoint 1

(SETPOINT 1)

Value:

Ref_{MIN} - Ref_{MAX}

★ 0.000

Function:

Setpoint 1 is used in closed loop as the reference to compare the feedback values with. See description of parameter 417 *Feedback function*. The setpoint can be offset with digital, analog or bus references, see *Reference handling*. Used in *Closed loop* [1] parameter 100 *Configuration*.

Description of choice:

Set the required value. The process unit is selected in parameter 415 *Process units*.

419 Setpoint 2

(SETPOINT 2)

Value:

Ref_{MIN} - Ref_{MAX}

★ 0.000

Function:

Setpoint 2 is used in closed loop as the reference to compare the feedback values with. See description of parameter 417 *Feedbackfunction*.

The setpoint can be offset with digital, analog or bus signals, see *reference handling*.

Used in *Closed loop* [1] parameter 100 *Configuration* and only if *2-zone minimum/maximum* is selected in parameter 417 *Feedbackfunction*.

Description of choice:

Set the required value. The process unit is selected in parameter 415 *Process units*.

420 PID normal/inverse control (PID NOR/INV. CTRL)

Value:

★Normal (NORMAL) [0]
Inverse (INVERSE) [1]

Function:

It is possible to choose whether the process regulator is to increase/reduce the output frequency if there is a deviation between reference/setpoint and the actual process state.

Used in *Closed loop* [1] (parameter 100).

Description of choice:

If the frequency converter is to reduce the output frequency in case the feedback signal increases, select *Normal* [0].

If the frequency converter is to increase the output frequency in case the feedback signal increases, select *Inverse* [1].

421 PID anti windup (PID ANTI WINDUP)

Value:

Off (DISABLE) [0]
★On (ENABLE) [1]

Function:

It is possible to choose whether the process regulator is to continue regulating on a deviation even if it is not possible to increase/reduce the output frequency.

Used in *Closed loop* [1] (parameter 100).

Description of choice:

The factory setting is *On* [1], which means that the integration link is adjusted to the actual output frequency if either the current limit, the voltage limit or the max./min. frequency has been reached. The process regulator will not be engaged again, until either the deviation is zero or its prefix has changed. Select *Off* [0] if the integrator is to continue integrating to the deviation even if it is not possible to remove the deviation by regulation.



NB!

If *Off* [0] is selected, it will mean that when the deviation changes its prefix, the integrator will first have to integrate down from the level obtained as a result of the former error, before any change to the output frequency occurs.

422 PID start-up frequency (PID START VALUE)

Value:

$f_{MIN}-f_{MAX}$ (parameter 201 and 202) ★ 0 Hz

Function:

When the start signal comes, the frequency converter will react in the form of *Open loop* [0] following the ramp. Only when the programmed start frequency has been obtained, will it change over to *Closed loop* [1]. In addition, it is possible to set a frequency that corresponds to the speed at which the process normally runs, which will enable the required process conditions to be reached sooner.

Used in *Closed loop* [1] (parameter 100).

Description of choice:

Set the required start frequency.



NB!

If the frequency converter is running at the current limit before the desired start frequency is obtained, the process regulator will not be activated. For the regulator to be activated anyway, the start frequency must be lowered to the required output frequency. This can be done during operation.



NB!

PID start frequency is always applied in clockwise direction.

423 PID proportional gain (PID PROP. GAIN)

Value:

0.00 - 10.00 ★ 0.01

Function:

The proportional gain indicates the number of times the deviation between the reference/setpoint and the feedback signal is to be applied.

Used in *Closed loop* [1] (parameter 100).

Description of choice:

Quick regulation is obtained by a high gain, but if the gain is too high, the process may become unstable.

424 PID integration time
(PID INTEGR.TIME)
Value:

0.01 - 9999.00 sec. (OFF) ★ OFF

Function:

The integrator provides a constant change of the output frequency during constant error between the reference/setpoint and the feedback signal. The greater the error, the quicker the integrator frequency contribution will increase. The integration time is the time needed by the integrator to reach the same gain as the proportional gain for a given deviation. Used in *Closed loop* [1] (parameter 100).

Description of choice:

Fast regulation is obtained in connection with a short integration time. However, this time may be too short, which means that the process may be destabilised as a result of overshings. If the integral time is long, major deviations from the required set point may occur, since the process regulator will take a long time to regulate in relation to a given error.

425 PID differentiation time
(PID DIFF. TIME)
Value:

0.00 (OFF) - 10.00 sec. ★ OFF

Function:

The differentiator does not react to a constant error. It only contributes when the error changes. The quicker the error changes, the stronger the contribution from the differentiator will be. This influence is proportional to the speed by which the deviation changes. Used in *Closed loop* [1] (parameter 100).

Description of choice:

Fast regulation can be obtained by means of a long differentiation time. However, this time may be too long, which means that the process may be destabilised as a result of overshings.

426 PID differentiator gain limit
(PID DIFF. GAIN)
Value:

5.0 - 50.0 ★ 5.0

Function:

It is possible to set a limit for the differentiator gain. The differentiator gain will increase if there are fast changes, which is why it can be beneficial to limit this gain, thereby obtaining a pure differentiator gain at slow changes and a constant differentiator gain where quick changes to the deviation are made. Used in *Closed loop* [1] (parameter 100).

Description of choice:

Select a limit to differentiator gain as required.

427 PID lowpass filter time
(PID FILTER TIME)
Value:

0.01 - 10.00 ★ 0.01

Function:

Oscillations on the feedback signal are dampened by the lowpass filter in order to reduce their impact on the process regulation. This can be an advantage if there is a lot of noise on the signal. Used in *Closed loop* [1] (parameter 100).

Description of choice:

Select the desired time constant (τ). If a time constant (τ) of 0.1 s is programmed, the break frequency for the lowpass filter will be $1/0.1 = 10 \text{ RAD/sec.}$, corresponding to $(10/(2 \times \pi)) = 1.6 \text{ Hz.}$ The process regulator will thus only regulate a feedback signal that varies by a frequency lower than 1.6 Hz. If the feedback signal varies by a higher frequency than 1.6 Hz, the Process regulator will not react.

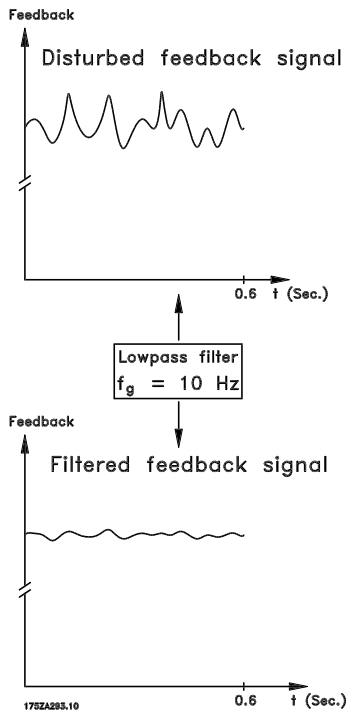

433 Motor Alternation Time (MOTOR ALT. TIME)

Value:

0 (OFF) - 999 hrs ★ OFF

Function:

This is the time that sets the length of time between motor alternation events. When the time elapses, the relay selected in parameter 323 or 326 changes state and initiates the external control devices that disconnect the active motor and connect the alternate motor. (Contactors or Starters used to connect and disconnect the motors are supplied by others.)

The timer resets after completion of the alteration sequence.

Parameter 434 - Motor Alteration Function, selects the type of stop - Ramp or Coast.

Description of choice:

Sets the time between motor alternation events.

434 Motor Alteration Function (MOTOR ALT. FUNCTION)

Value:

- ★ Ramp (RAMP) [0]
- Coast (COAST) [1]

Function:

When a motor is stopped after the duration set in parameter 433, *Motor alternation time* expires, the motor is commanded to either coast or ramp to a stop. If the motor is not running at the time of alteration, the relay simply changes state. If the motor is running at the time of alteration, a start command is sent following alteration. Motor Alteration is displayed on the drive control panel during alternation.

When *Coast* is selected, after coasting is initiated, a delay of 2 seconds occurs prior to the relay changing state. Ramp-down time is set in parameter 207.

Description of choice:

Set the desired stop function.

483 Dynamic DC link compensation (DC LINK COMP.)

Value:

- Off [0]
- ★ On [1]

Function:

The frequency converter includes a feature, which ensures that the output voltage is independent of any voltage fluctuation in the DC link, e.g. caused by fast fluctuation in the mains supply voltage. The benefit is a very steady torque on motor shaft (low torque ripple) under most mains conditions.

Description of choice:

In some cases this dynamic compensation can cause resonance's in the DC link and should then be disabled. Typical cases are where a line choke or a passive harmonic filter (e.g. filters AHF005/010) is mounted in the mains supply to the frequency converter to suppress harmonics. Can also occur on mains with low short circuit ratio.



NB!:

This is a hidden parameter. The only access is with the MCT 10 software tool.

Programming

★ = factory setting. () = display text [] = value for use in communication via serial communication port

Serial communication for FC protocol

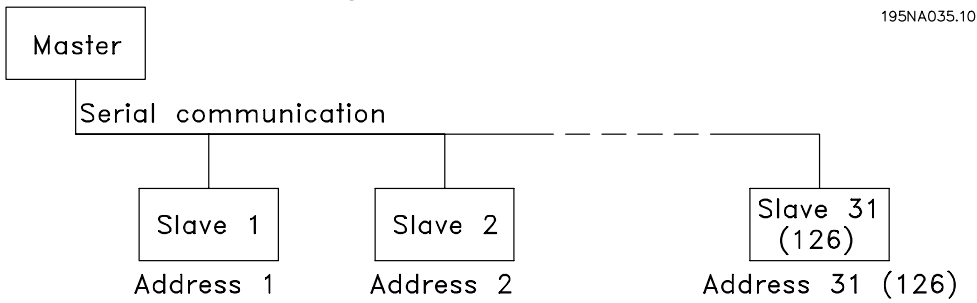

Protocols

As standard, all VLT 8000 AQUA units have a RS 485 port which enables a choice among four protocols.

- FC
- Profibus*
- Modbus RTU*
- DeviceNet*
- LonWorks*

* Please note that these are option cards with separate input terminals.

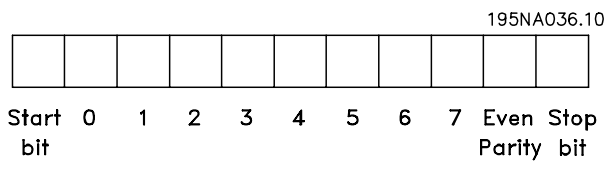

Telegram communication

Control and reply telegrams

The telegram communication in a master/slave system is controlled by the master. A maximum of 31 slaves can be connected to one master, unless a repeater is used. If a repeater is used, a maximum of 126 slaves can be connected to one master.

The master continuously sends telegrams addressed to the slaves and awaits reply telegrams from these. The response time of the slaves is max. 50 ms.

Only a slave that has received a faultless telegram addressed to that slave will respond by sending a reply telegram.

Broadcast

A master can send the same telegram at the same time to all slaves connected to the bus. In such *broadcast* communication, the slave does not send a reply telegram to the master, provided the telegram has been correctly received. *Broadcast* communication is set up in the address format (ADR), see the next page. Contents of a character (byte)

Each transferred character begins with a start bit. Subsequently, 8 data-bits are transferred, corresponding to one byte. Each character is secured via a parity bit set to "1" when there is even parity (i.e. an even number of binary 1's in the 8 data-bits and the parity bit combined). A character ends with a stop bite and thus consists of a total of 11 bits.

Telegram build-up under FC protocol

Each telegram begins with a start character (STX) = 02 Hex, followed by a byte that gives the telegram length (LGE) and a byte that gives the VLT address (ADR). Then follows a number of data bytes (variable, depending on telegram type). The telegram ends with a data control byte (BCC).

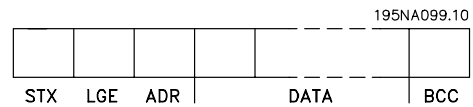

Telegram times

The speed of communication between a master and a slave depends on the baud rate. The baud rate of the frequency converter must be the same as the baud rate of the master and is selected in parameter 502 *Baudrate*.

After a reply telegram from the slave, there must be a minimum pause of 2 characters (22 bits) before the master is able to send another telegram. At a baudrate of 9600 kbaud, there must be a minimum pause of 2.3 msec. After the master has completed the telegram, the response time of the slave back to the master will be max. 20 msec. and there will be a minimum pause of 2 characters.

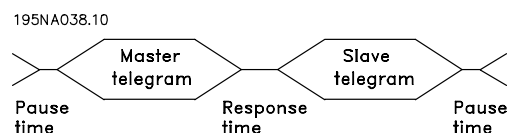

Pause time, min.:	2 characters
Response time, min.:	2 characters
Response time, max.:	20 msec.

The time between individual characters in a telegram is not to exceed 2 characters and the telegram must be completed within 1.5 times the rated telegram time.

If the baudrate is 9600 kbaud and the telegram length is 16 baud, the telegram must be completed within 27.5 msec.

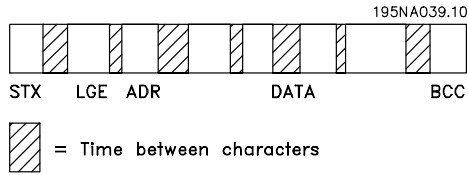

Telegram length (LGE)

The telegram length is the number of data bytes plus address byte ADR plus data control byte BCC.

Telegrams with 4 data bytes have a length of:

$$LGE = 4 + 1 + 1 = 6 \text{ bytes}$$

Telegrams with 12 data bytes have a length of:

$$LGE = 12 + 1 + 1 = 14 \text{ bytes}$$

Telegrams that contain text have a length of 10+n bytes. 10 is the fixed characters, while 'n' is variable (depending on the length of the text).

Frequency converter address (ADR)

Two different address formats are used, in which the address range of the frequency converter is either from 1-31 or from 1-126.

1. Address format 1-31

The byte for this address range has the following profile:

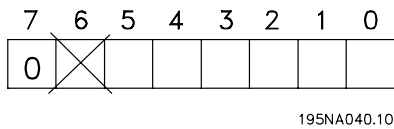

Bit 7 = 0 (address format 1-31 active)

Bit 6 is not used

Bit 5 = 1: Broadcast, address bits (0-4), not used

Bit 5 = 0: No Broadcast

Bit 0-4 = frequency converter address 1-31

2. Address format 1-126

The byte for the 1-126 address range has the following profile:

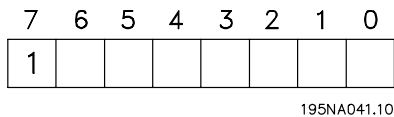

Bit 7 = 1 (address format 1-126 active)

Bit 0-6 = frequency converter address 1-126

Bit 0-6 = 0 Broadcast

The slave sends the address byte back to the master in the reply telegram in unchanged form.

Example:

A telegram is sent to frequency converter address 22 using address format 1-31:

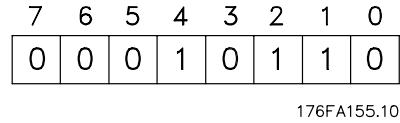

Data control byte (BCC)

The data control byte can be explained by means of an example: Before the first byte of the telegram is received, the calculated check sum (BCS) is 0.

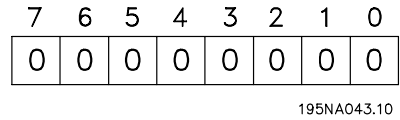

After the first byte (02H) has been received:

$$\begin{aligned} \text{BCS} &= \text{BCC EXOR "first byte"} \\ &\quad (\text{EXOR} = \text{exclusive-or gate}) \\ \text{BCS} &= 00000000 \text{ (00H)} \\ \text{"first byte"} &= 00000100 \text{ (02H)} \\ \hline \text{BCC} &= 00000100 \end{aligned}$$

Each additional, subsequent byte is gated with BCS EXOR and results in a new BCC, such as:

$$\begin{aligned} \text{BCS} &= 00000100 \text{ (02H)} \\ \text{"second byte"} &= 11010110 \text{ (D6H)} \\ \hline \text{BCC} &= 11010100 \end{aligned}$$

■ Data character (byte)

The build-up of data blocks depends on the type of telegram. There are three types of telegram and the telegram type applies to both control telegram (master ⇒ slave) and reply telegram (slave ⇒ master). The three types of telegram are the following:

1. Parameter block, used for transferring parameters between master and slave. The data block has 12 bytes (6 words) and also contains the process block. 195NA044.10

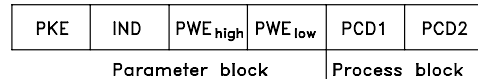

2. Process block, built up as a data block with four bytes (2 words), covering:

- Control word and reference value (from master to slave)
- Status word and present output frequency (from slave to master).

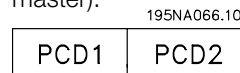

3. Text block, used for reading or writing texts via the data block.

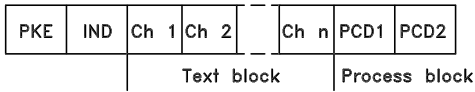

1. Parameter bytes

195NA046.10

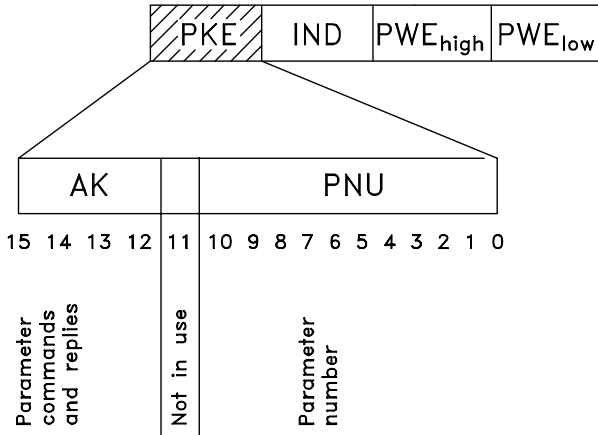

Parameter commands and replies (AK) Bits no. 12-15 are used for transferring parameter commands from master to slave and the slave's processed reply back to the master.

Parameter commands → master slave:

Bit no.	15	14	13	12	Parameter command
0	0	0	0	0	No command
0	0	0	1	0	Read parameter value
0	0	1	0	0	Write parameter value in RAM (word)
0	0	1	1	0	Write parameter value in RAM (double word)
1	1	0	1	0	Write parameter value in RAM and EEPROM (double word)
1	1	1	0	0	Write parameter value in RAM and EEPROM (word)
1	1	1	1	0	Read/write text

Reply slave → master:

Bit no.	15	14	13	12	Reply
0	0	0	0	0	No reply
0	0	0	1	0	Parameter value transferred (word)
0	0	1	0	0	Parameter value transferred (double word)
0	1	1	1	1	Command cannot be executed
1	1	1	1	1	Text transferred

If the command cannot be carried out, the slave will send this reply (0111) *Command cannot be executed* and give the following error message in the parameter value (PWE):

(reply 0111)	Error message
0	The parameter number used does not exist
1	There is no write access to the parameter called
2	The data value exceeds the parameter limits
3	The used sub-index does not exist
4	The parameter is not of the array type
5	The data type does not match the parameter called
17	Data change in the parameter called is not possible in the present mode of the frequency converter. E.g. some parameters can only be changed when the motor has stopped
130	There is no bus access to the parameter called
131	Data change is not possible because factory Setup has been selected

Parameter number (PNU)

Bits no. 0-10 are used for transmitting parameter numbers. The function of a given parameter is defined in the parameter description in the *Programming* section.

Index



Index is used together with the parameter number for read/write access to parameters with an index, such as parameter 615 *Error code*. Index has 2 bytes - a lowbyte and a highbyte. However, only the lowbyte is used. See example below.

Example - Index:

The first error code (index [1]) in parameter 615 *Error code* must be read.

PKE = 1267 Hex (read parameter 615 *Error code*). IND = 0001 Hex - Index no. 1.

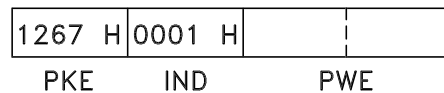

The frequency converter will respond in the parameter value (PWE) block by means of an error code

with a value from 1-99. See *List of warnings and alarms* to identify the error code.

Parameter value (PWE)

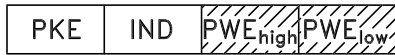

The parameter value block consists of 2 words (4 bytes) and its value depends on the command given (AK). If the master enquires about a parameter value, the PWE block contains no value.

If a parameter value is to be changed by the master (write), the new value is entered in the PWE block and sent to the slave.

If the slave responds to a parameter requirement (read command), the present parameter value is transferred in the PWE block and returned to the master.

If a parameter does not contain a numerical value, but several data selection options, e.g. parameter 001 *Language*, where [0] is *English* and [1] is *Danish*, the data value is selected by writing the value in the PWE block. See example on the following page.

Via the serial communication it is only possible to read parameters with data type 9 (text string). In VLT 8000 AQUA, parameters 621-631 *Nameplate data* have data type 9. For example, it is possible in parameter 621 (Unit Type) to read the unit size and mains voltage range.

When a text string is transferred (read), the telegram length is variable, since the texts have different lengths. The telegram length is stated in the 2nd byte of the telegram, called LGE.

In order to read a text via the PWE block, the parameter command (AK) must be set to 'F' Hex.

The index character is used to indicate whether the command in question is a read or write command. For a read command, the index must have the following format:

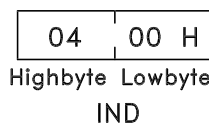

VLT 8000 AQUA has two parameters for which a text can be written: parameters 533 and 534 *Display text*, see the description of these under the parameter

description. In order to write a text via the PWE block, the parameter command (AK) must be set to 'F' Hex.

For a write command, the index must have the following format:

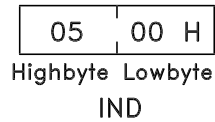

Data types supported by the frequency converter

Datatype	Description
3	Integer 16
4	Integer 32
5	Unsigned 8
6	Unsigned 16
7	Unsigned 32
9	Text string

Unsigned means there is no sign included in the telegram.

Example - Write a parameter value:

Parameter 202 *Output frequency high limit, f_{MAX}* is to be changed to 100 Hz. This value must be remembered after a power failure, so it is written in EEPROM.

PKE = E0CA Hex - Write to parameter 202
Output frequency high limit, f_{MAX}
 IND = 0000 Hex
 PWE_{HIGH} = 0000 Hex
 PWE_{LOW} = 03E8 Hex - Data value 1000, corresponding to 100 Hz, see *Conversion*.

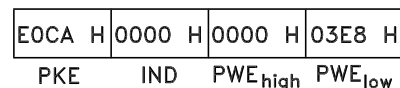

The reply from the slave to the master will be:

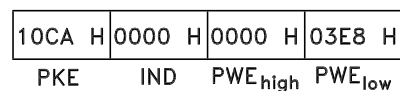

Example - Choice of a data value:

kW [20] is to be selected in parameter 415 *Process units*. This value must be remembered after a power failure, so it is written in EEPROM.

PKE = E19F Hex - Write to parameter 415
Process units
 IND = 0000 Hex
 PWE_{HIGH} = 0000 Hex
 PWE_{LOW} = 0014 Hex - Choose data choice kW [20]

<small>176FA198.10</small>			
E19F H	0000 H	0000 H	0014 H
PKE	IND	PWE _{high}	PWE _{low}

The reply from the slave to the master will be:

<small>176FA199.10</small>			
119F H	0000 H	0000 H	0014 H
PKE	IND	PWE _{high}	PWE _{low}

Example - Read a parameter value:

The value in parameter 206 *Ramp-up time* is required. The master sends the following inquiry:

PKE = 10CE Hex - read parameter 206
Ramp-up time
 IND = 0000 Hex
 PWE_{HIGH} = 0000 Hex
 PWE_{LOW} = 0000 Hex

<small>175ZA708.10</small>			
10CE H	0000 H	0000 H	0000 H
PKE	IND	PWE _{high}	PWE _{low}

If the parameter value in parameter 206 *Ramp-up time* is 10 seconds, the reply from the slave to the master will be as follows:

<small>175ZA709.10</small>			
10CE H	0000 H	0000 H	000A H
PKE	IND	PWE _{high}	PWE _{low}

Conversion:

The different attributes for each parameter can be seen in the section on *factory settings*. Since a parameter value can only be transferred as a whole number, a conversion factor must be used to transfer decimals.

Example:

Parameter 201: minimum frequency, conversion factor 0.1. If parameter 201 is to be set to 10 Hz, a value of 100 must be transferred, since a conversion factor of 0.1 means that the transferred value will be multiplied by 0.1. A value of 100 will thus be understood as 10.0.

Conversion table:

Conversion index	Conversion factor
74	3.6
2	100
1	10
0	1
-1	0.1
-2	0.01
-3	0.001
-4	0.0001

■ **Process word**

The process word block is divided into two blocks each of 16 bits, which always come in the sequence stated.

<small>195NA066.10</small>	
PCD1	PCD2

	PCD1	PCD 2
Control telegram (master → slave)	Control word	Reference value
Reply telegram (slave → master)	Status word	Given output frequency

■ Control word according to FC protocol

The control word is used for transmitting commands from a master (e.g. a PC) to a slave.

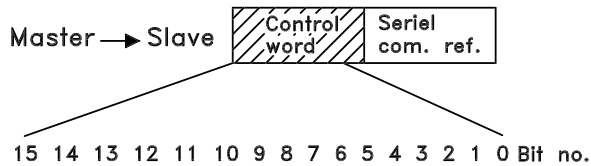

Bit	Bit = 0	Bit = 1
00		Preset ref. lsb
01		Preset ref. msb
02	DC braking	
03	Coasting stop	
04	Quick stop	
05	Freeze output frequency	
06	Ramp stop	Start
07		Reset
08		Jog
09	No function	No function
10	Data not valid	Data valid
11		Activate relay 1
12		Activate relay 2
13		Choice of setup lsb
14		Choice of setup msb
15		Reversing

Bit 00/01:

Bits 00 and 01 are used for choosing between the four pre-programmed references (parameters 211- 214 *Preset reference*) in accordance with the following table:

Preset ref.	Parameter	Bit 01	Bit 00
1	211	0	0
2	212	0	1
3	213	1	0
4	214	1	1



NB!:

Parameter 508 *Choice of preset reference* is used to choose how bits 00/01 are to be gated with the corresponding functions of the digital inputs.

Bit 02, DC BRAKE:

Bit 02 = 0 leads to DC braking and stop. Set braking current and duration in parameter 114 *DC braking current* and in parameter 115 *DC braking time*. Note: Parameter 504 *DC brake* is used for selecting how bit 02 is to be gated with the corresponding function of terminal 27.

Bit 03, Coasting stop:

Bit 03 = "0" means that the frequency converter immediately "lets go" of the motor (the output transistors are "turned off"), which means that the motor runs freely until it stops.
Bit 03 = "1" means that the frequency converter is able to start the motor, provided the other conditions for

starting are fulfilled. Note: In parameter 503 *Coasting stop* the choice is made of how bit 03 is to be gated with the corresponding function of terminal 27.

Bit 04, Quick stop:

Bit 04 = "0" leads to a stop in which the motor speed is ramped down to stop via parameter 207 *Ramp-down time*.

Bit 05, Freeze output frequency:

Bit 05 = "0" means that the given output frequency (in Hz) is frozen. The frozen output frequency can now only be changed via the digital inputs programmed for *Speed up* and *Speed down*.



NB!:

If *Freeze output* is active, the frequency converter cannot be stopped via Bit 06 *Start* or via terminal 18. The frequency converter can only be stopped in the following ways:

- Bit 03 *Coasting stop*
- Terminal 27
- Bit 02 *DC braking*
- Terminal 19 programmed for *DC braking*

Bit 06, Ramp stop/start:

Bit 04 = "0" leads to a stop in which the motor speed is ramped down to stop via parameter 207 *Ramp-down time*.

Bit 06 = "1" means that the frequency converter is able to start the motor, provided the other conditions for starting are fulfilled. Note: In parameter 505 *Start a choice* is made of the way bit 06 *Ramp stop/start* is to be gated with the corresponding function of terminal 18.

Bit 07, Reset:

Bit 07 = "0" leads to no reset.

Bit 07 = "1" means that a trip is reset.

Reset is activated on the leading edge of the signal, i.e. at the change from logic '0' to logic '1'.

Bit 08, Jog:

Bit 08 = "1" means that the output frequency is determined by parameter 209 *Jog frequency*.

Bit 09, No function:

Bit 09 has no function.

Bit 10, Data not valid/Data valid:

Used for telling the frequency converter whether the control is to be used or ignored. Bit 10 = "0" means that the control word is ignored. Bit 10 = "1" means that the control word is used. This function is relevant because the control word is always

contained in the telegram, regardless of the type of telegram used, i.e. it is possible to disconnect the control word if it is not to be used in connection with updating or reading of parameters.

Bit 11, Relay 1:

Bit 11 = "0": Relay 1 is not activated.

Bit 11 = "1": Relay 1 is activated, provided *Control word bits 11/12* has been selected in parameter 323 *Relay outputs*.

Bit 12, Relay 2:

Bit 12 = "0": Relay 2 is not activated.

Bit 12 = "1": Relay 2 is activated, provided *Control word bits 11/12* has been selected in parameter 326 *Relay outputs*.

NB!:

If the time-out period set in parameter 556 *Bus time interval function* is exceeded, relays 1 and 2 will lose their voltage if they have been activated via serial communication.

Bits 13/14, Choice of Setup:

Bits 13 and 14 are used to choose among the four menu Setups in accordance with the following table:

Setup	Bit 14	Bit 13
1	0	0
2	0	1
3	1	0
4	1	1

This function is only possible if *Multi-setups* has been selected in parameter 004.

Note: In parameter 507 *Choice of Setup* a choice is made of the way bits 13/14 are to be gated with the corresponding function of the digital inputs.

Bit 15, No function/reversing:

Bit 15 = "0" leads to no reversing.

Bit 15 = "1" leads to reversing.

Please note that, in the factory setting, reversing has been selected as digital in parameter 506 *Reversing*, which means that bit 15 only leads to reversing, if *bus, logic or orlogic* and has been selected (however, *logic* and only together with terminal 19).

■ Status word according to FC protocol

The status word is used to inform the master (e.g. a PC) of the condition of the slave (VLT 8000 AQUA).

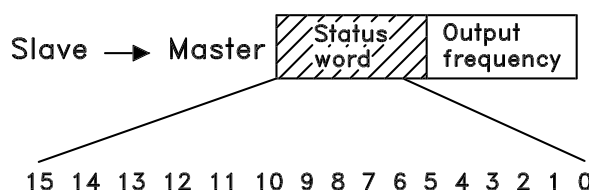

Bit	Bit = 0	Bit = 1
00	Trip	Control ready
01		Drive ready
02		Stand by
03	No trip	Trip
04	Not in use	
05	Not in use	
06	Not in use	
07	No warning	Warning
08	Speed ≠ ref.	Speed = ref.
09	Local operation	Serial com. control
10	Out of frequency range	
11		Running
12	No function	No function
13		Voltage warning high/low
14		Current limit
15		Thermal warning

Bit 00, Control ready:

Bit 00 = "1". The frequency converter is ready for operation.

Bit 00 = "0". The frequency converter has tripped.

Bit 01, Drive ready:

Bit 01 = "1". The frequency converter is ready for operation, but terminal 27 is a logic '0' and/or a *coasting command* has been received via serial communication.

Bit 02, Stand by:

Bit 02 = "1". The frequency converter is able to start the motor when a start command is given.

Bit 03, No trip/trip:

Bit 03 = "0" means that the VLT 8000 AQUA is not in an error state.

Bit 03 = "1" means that the VLT 8000 AQUA has tripped and needs a reset signal in order for operation to be resumed.

Bit 04, Not in use:

Bit 04 is not used in the status word.

Bit 05, Not in use:

Bit 05 is not used in the status word.

Bit 06, trip lock:

Bit 06 = "1" means that there is a trip lock.

Bit 07, No warning/warning:

Bit 07 = "0" means there is no warning. Bit 07 = "1" means a warning has occurred.

Bit 08, Speed ≠ ref./speed = ref.:

Bit 08 = "0" means that the motor is running, but that the present speed is different from the preset speed reference. This may be the case, i.a. when the speed is ramped up/down at start/stop.

Bit 08 = "1" means that the present motor speed equals the preset speed reference.

Bit 09, Local operation/serial communication control:

Bit 09 = "0" means that OFF/STOP has been activated on the control unit, or that the VLT 8000 AQUA is in Hand mode. It is not possible to control the frequency converter via serial communication.

Bit 09 = "1" means that it is possible to control the frequency converter via serial communication.

Bit 10, Out of frequency range:

Bit 10 = "0" if the output frequency has reached the value in parameter 201 *Output frequency low limit* or parameter 202 *Output frequency high limit*. Bit 10 = "1" means that the output frequency is within the limits stated.

Bit 11, Not running/running:

Bit 11 = "0" means that the motor is not running.

Bit 11 = "1" means that the VLT 8000 AQUA has a start signal, or that the output frequency is greater than 0 Hz.

Bit 12, No function:

Bit 12 has no function.

Bit 13, Voltage warning high/low:

Bit 13 = "0" means that there is no voltage warning.

Bit 13 = "1" means that the DC voltage of the VLT 8000 AQUA intermediate circuit is too low or too high.

See the voltage limits in *Warnings and alarms*.

Bit 14, Current limit:

Bit 14 = "0" means that the output current is smaller than the value in parameter 215 *Current limit I_{LIM}*.

Bit 14 = "1" means that the output current is higher than the value in parameter 215 *Current limit I_{LIM}* and the frequency converter will trip after the time set in parameter 412 *Trip delay overcurrent*, *I_{LIM}* has passed.

Bit 15, Thermal warning:

Bit 15 = "0" means there is no thermal warning. Bit 15 = "1" means that the temperature limit has been exceeded either in the motor, in the frequency converter or from a thermistor connected to an analogue input.

■ **Serial communication reference**

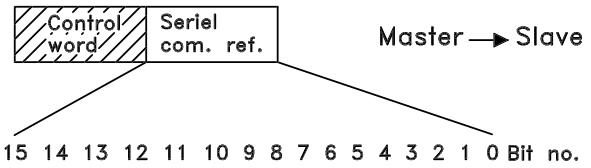

The serial communication reference is transmitted to the frequency converter in the form of a 16-bit word. The value is transmitted as whole numbers 0 - ±32767 (±200 %). 16384 (4000 Hex) corresponds to 100 %.

The serial communication reference has the following format:

0-16384 (4000 Hex) - 0-100 % (par. 204 *Minimum ref.* - Par. 205 *Maximum ref.*).

It is possible to change the direction of rotation via the serial reference. This is done by converting the binary reference value to 2's complement. See example.

Example - control word and serial communication ref.:

The frequency converter must receive a start command, and the reference is to be set to 50 % (2000 Hex) of the reference range.

Control word = 047F Hex. Start command
Reference = 2000 Hex. 50 % reference

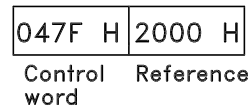

The frequency converter is to receive a start command, and the reference is to be set to -50 % (-2000 Hex) of the reference range.

The reference value is first converted to the first complement; then 1 binary is added to get 2's complement:

2000 Hex = 0010 0000 0000 0000 binary
1 1101 1111 1111 1111 binary
komplement

=
+ 1 binary
2 1110 0000 0000 0000 binary
komplement

=

Control word = 047F Hex. Start command
Reference = E000 Hex. -50 % reference

047F H	E000 H
Control word	Reference

■ Present output frequency

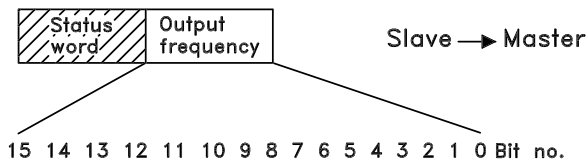

The value of the present output frequency of the frequency converter at any given time is transmitted as a 16-bit word. The value is transmitted in the form of whole numbers 0 -± 32767 (±200 %). 16384 (4000 Hex) corresponds to 100 %.

The output frequency has the following format:

0-16384 (4000 Hex) \cong 0-100 % (Par. 201 *Output frequency low limit* - Par. 202 *Output frequency high limit*).

Example - Status word and present output frequency:

The master receives a status message from the frequency converter saying that the present output frequency is 50 % of the output frequency range.

Par. 201 *Output frequency low limit* = 0 Hz
 Par. 202 *Output frequency high limit* = 50 Hz

Status word = 0F03 Hex. Status message
 Output frequency = 2000 Hex. 50 % of the frequency range, corresponding to 25 Hz.

0F03 H	2000 H
Status word	Output frequency

Serial communication 500-556

In this parameter group, the serial communication of the frequency converter is set up. In order to use serial communication, address and baudrate must always be set. In addition, such present operational data as reference, feedback and motor temperature can be read via serial communication.

500 Protocol (PROTOCOL)

Value:

★FC protocol (FC PROTOKOL)	[0]
Modbus RTU (MODBUS RTU)	[1]

501 Address (ADDRESS)

Value:

Parameter 500 Protocol = FC protocol [0]	
0 - 126	★ 1
Parameter 500 Protocol = MODBUS RTU [1]	★ 1

Function:
In this parameter it is possible to allocate an address in a serial communication network to each frequency converter.

Description of choice:
The individual frequency converter must be given a unique address. If the number of units connected (frequency converter + master) exceeds 31, an amplifier (repeater) must be used. Parameter 501 Address cannot be chosen via serial communication, but must be set via the LCP control unit.

502 Baudrate (BAUDRATE)

Value:

300 Baud (300 BAUD)	[0]
600 Baud (600 BAUD)	[1]
1200 Baud (1200 BAUD)	[2]
2400 Baud (2400 BAUD)	[3]
4800 Baud (4800 BAUD)	[4]
★9600 Baud (9600 BAUD)	[5]

Function:
In this parameter, the speed is programmed at which data is transmitted via serial communication. Baudrate is defined as the number of bits transmitted per second.

Description of choice:

The transmission speed of the frequency converter must be set at a value that corresponds to the transmission speed of the master. Parameter 502 Baudrate cannot be selected via serial communication; it must be set via the LCP control unit. The data transmission time itself, which is determined by the baudrate selected, is only part of the total communication time.

503 Coasting stop (COASTING)

Value:

Digital input (DIGITAL INPUT)	[0]
Serial communication (SERIAL PORT)	[1]
Logic and (LOGIC AND)	[2]
★Logic or (LOGIC OR)	[3]

Function:

In parameters 503-508, a choice can be made to control the frequency converter via the digital inputs and/ or via serial communication. If *Serial communication* [1] is selected, the command in question can only be activated if a command is given via serial communication. If *Logic and* [2] is selected, the function must in addition be activated via a digital input.

Description of choice:

The table below shows when the motor is running and is coasting when *Digital input* [0], *Serial communication* [1], *Logic and* [2] or *Logic or* [3] has been selected.

NB!
 Please note that terminal 27 and bit 03 of the control word are active in the case of logic '0'.

Digital input [0]			Serial communication [1]		
Serial			Serial		
Kl. 27	com.	Function	Kl. 27	com.	Function
0	0	Coasting	0	0	Coasting
0	1	Coasting	0	1	Motor run.
1	0	Motor run.	1	0	Coasting
1	1	Motor run.	1	1	Motor run.
Logic and[2]			Logic or[3]		
Serial			Serial		
Kl. 27	com.	Function	Kl. 27	com.	Function
0	0	Coasting	0	0	Coasting
0	1	Motor run.	0	1	Coasting
1	0	Motor run.	1	0	Coasting
1	1	Motor run.	1	1	Motor run.

★ = factory setting. () = display text [] = value for use in communication via serial communication port

504 DC brake

(DC BRAKE)

Value:

Digital input (DIGITAL INPUT)	[0]
Serial communication (SERIAL PORT)	[1]
Logic and (LOGIC AND)	[2]
★Logic or (LOGIC OR)	[3]

Function:

See functional description under parameter 503 *Coasting*.

Description of choice:

The table below shows when the motor is running and is DC-braking when *Digital input* [0], *Serial communication* [1], *Logic and* [2] or *Logic or* [3] has been selected.



NB!:

Please note that *DC braking inverse* [3] via terminal 19, terminal 27 and bit 03 of the control word is active in the case of logic '0'.

<i>Digital input</i> [0]			<i>Serial communication</i> [1]		
Term.	Serial		Term.	Serial	
19/27	com.	Function	19/27	com.	Function
0	0	DC-brake	0	0	DC-brake
0	1	DC-brake	0	1	Motor run.
1	0	Motor run.	1	0	DC-brake
1	1	Motor run.	1	1	Motor run.
<i>Logic and</i> [2]			<i>Logic or</i> [3]		
Term.	Serial		Term.	Serial	
19/27	com.	Function	19/27	com.	Function
0	0	DC-brake	0	0	DC-brake
0	1	Motor run.	0	1	DC-brake
1	0	Motor run.	1	0	DC-brake
1	1	Motor run.	1	1	Motor run.

505 Start

(START)

Value:

Digital input (DIGITAL INPUT)	[0]
Serial communication (SERIAL PORT)	[1]
Logic and (LOGIC AND)	[2]
★Logic or (LOGIC OR)	[3]

Function:

See functional description under parameter 503 *Coasting*.

Description of choice:

The table below shows when the motor has stopped and gives the situations in which the frequency converter has a start command when *Digital input*

[0], *Serial communication* [1], *Logic and* [2] or *Logic or* [3] has been selected.

<i>Digital input</i> [0]			<i>Serial communication</i> [1]		
Kl.18	Serial		Kl.18	Serial	
	com.	Function		com.	Function
0	0	Stop	0	0	Stop
0	1	Stop	0	1	Start
1	0	Start	1	0	Stop
1	1	Start	1	1	Start
<i>Logic and</i> [2]			<i>Logic or</i> [3]		
Kl.18	Serial		Kl.18	Serial	
	com.	Function		com.	Function
0	0	Stop	0	0	Stop
0	1	Stop	0	1	Start
1	0	Stop	1	0	Start
1	1	Start	1	1	Start

506 Reversing

(REVERSING)

Value:

★Digital input (DIGITAL INPUT)	[0]
Serial communication (SERIAL PORT)	[1]
Logic and (LOGIC AND)	[2]
Logic or (LOGIC OR)	[3]

Function:

See functional description under parameter 503 *Coasting*.

Description of choice:

The table below shows when the motor is running clockwise and anti-clockwise when *Digital input* [0], *Serial communication* [1], *Logic and* [2] or *Logic or* [3] has been selected.

Digital input [0]			Serial communication [1]		
Kl.19	com.Function		Kl.19	com.Function	
0	0	Clockwise	0	0	Clockwise
0	1	Clockwise	0	1	Counter-clock
1	0	Counter-clock.	1	0	Clockwise
1	1	Counter-clock.	1	1	Counter-clock.
Logic and [2]			Logic or [3]		
Kl.19	com.Function		Kl.19	com.Function	
0	0	Clockwise	0	0	Clockwise
0	1	Clockwise	0	1	Counter-clock.
1	0	Clockwise	1	0	Counter-clock.
1	1	Counter-clock.	1	1	Counter-clock.

507 Selection of Setup

(SELECTING OF SETUP)

508 Selection of preset reference

(SELECTING OF SPEED)

Value:

Digital input (DIGITAL INPUT)	[0]
Serial communication (SERIAL PORT)	[1]
Logic and (LOGIC AND)	[2]
★Logic or (LOGIC OR)	[3]

Function:

See functional description under parameter 503 *Coasting*.

Description of choice:

The table below shows the Setup (parameter 002 *Active Setup*) that has been selected via *Digital input* [0], *Serial communication* [1], *Logic and* [2] or *Logic or* [3].
The table also shows the preset reference (parameters 211-214 *Preset reference*) that has been selected via *Digital input* [0], *Serial communication* [1], *Logic and* [2] or *Logic or* [3].

Digital input [0]				
Bus msb	Bus lsb	Setup/Pre-set msb	Setup/Pre-set lsb	Setup no. Preset ref. no.
0	0	0	0	1
0	0	0	1	2
0	0	1	0	3
0	0	1	1	4
0	1	0	0	1
0	1	0	1	2
0	1	1	0	3
0	1	1	1	4
1	0	0	0	1
1	0	0	1	2
1	0	1	0	3
1	0	1	1	4
1	1	0	0	1
1	1	0	1	2
1	1	1	0	3
1	1	1	1	4

Serial communication [1]				
Bus msb	Bus sb	Setup/Pre-set msb	Setup/Pre-set lsb	Setup no. Preset ref. no.
0	0	0	0	1
0	0	0	1	1
0	0	1	0	1
0	0	1	1	1
0	1	0	0	2
0	1	0	1	2
0	1	1	0	2
0	1	1	1	2
1	0	0	0	3
1	0	0	1	3
1	0	1	0	3
1	0	1	1	3
1	1	0	0	4
1	1	0	1	4
1	1	1	0	4
1	1	1	1	4

Logic and [2]				
Bus msb	Bus lsb	Setup/Pre-set msb	Setup/Pre-set lsb	Setup no. Preset ref. no.
0	0	0	0	1
0	0	0	1	1
0	0	1	0	1
0	0	1	1	1
0	1	0	0	1
0	1	0	1	2
0	1	1	0	1
0	1	1	1	2
1	0	0	0	1
1	0	0	1	1
1	0	1	0	3
1	0	1	1	3
1	1	0	0	1
1	1	0	1	2
1	1	1	0	3
1	1	1	1	4

★ = factory setting. () = display text [] = value for use in communication via serial communication port

<i>Logic or [3]</i>				
Bus msb	Bus lsb	Setup/Pre- set msb	Setup/Pre- set lsb	Setup no. Preset ref. no.
0	0	0	0	1
0	0	0	1	2
0	0	1	0	3
0	0	1	1	4
0	1	0	0	2
0	1	0	1	2
0	1	1	0	4
0	1	1	1	4
1	0	0	0	3
1	0	0	1	4
1	0	1	0	3
1	0	1	1	4
1	1	0	0	4
1	1	0	1	4
1	1	1	0	4
1	1	1	1	4

★ = factory setting. () = display text [] = value for use in communication via serial communication port

509 - 532 Data read-out

Value:				
Parameter no.	Description	Display text	Unit	Updating interval
509	Resulting reference	(REFERENCE %)	%	80 msec.
510	Resulting reference [unit]	(REFERENCE [UNIT])	Hz, rpm	80 msec.
511	Feedback [unit]	(FEEDBACK)	Par. 415	80 msec.
512	Frequency [Hz]	(FREQUENCY)	Hz	80 msec.
513	User-defined read-out	(CUSTOM READOUT)	Hz x scaling	80 msec.
514	Motor current [A]	(CURRENT)	Amp	80 msec.
515	Power [kW]	(POWER KW)	kW	80 msec.
516	Motor voltage [V]	(POWER HK)	HP	80 msec.
517	Motor voltage [V]	(MOTOR VOLT)	V _{AC}	80 msec.
518	DC link voltage [V]	(DC LINK VOLTAGE)	V _{DC}	80 msec.
519	Thermal load, motor [%]	(MOTOR TEMPERATURE)	%	80 msec.
520	Thermal load, VLT [%]	(VLT TEMPERATURE)	%	80 msec.
521	Digital input	(DIGITAL INPUT)	Binary	80 msec.
522	Terminal 53, analog input [V]	(TERMINAL 53, ANALOG INPUT)	Volt	20 msec.
523	Terminal 54, analog input [V]	(TERMINAL 54, ANALOG INPUT)	Volt	20 msec.
524	Terminal 60, analogue input [mA]	(TERMINAL 60, ANALOG INPUT)	mA	20 msec.
525	Pulse reference [Hz]	(PULSE REFERENCE)	Hz	20 msec.
526	External reference [%]	(EXTERNAL REFERENCE)	%	20 msec.
527	Status word	(STATUS WORD HEX)	Hex	20 msec.
528	Heat sink temperature [°C]	(HEAT SINK TEMP.)	°C	1.2 sec.
529	Alarm word	(ALARM WORD, HEX)	Hex	20 msec.
530	Control word	(VLT CONTROL WORD, HEX)	Hex	2 msec.
531	Warning word	(WARN. WORD)	Hex	20 msec.
532	Extended status word	(STATUS WORD)	Hex	20 msec.
537	Relay status	(RELAY STATUS)	Binary	80 msec.

Function:

These parameters can be read out via the serial communication port and via the display. See also parameters 007-010 *Display read-out*.

gives the output frequency from the frequency converter.

Description of choice:

Resulting reference, parameter 509:

gives a percentage for the resulting reference in the range from *Minimum reference, Ref_{MIN}* to *Maximum reference, Ref_{MAX}*. See also *Reference handling*.

Resulting reference [unit], parameter 510:

gives the resulting reference by means of the unit Hz in *Open loop* (parameter 100). In *Closed loop*, the reference unit is selected in parameter 415 *Units with closed loop*.

Feedback [unit], parameter 511:

gives the resulting feedback value by means of the unit/scaling selected in parameters 413, 414 and 415. See also *Feedback handling*.

Frequency [Hz], parameter 512:

★ = factory setting. () = display text [] = value for use in communication via serial communication port

User-defined read-out, parameter 513:

gives a user-defined value calculated on the basis of the present output frequency and unit, as well as the scaling in selected in parameter 005 *Max. value of user-defined read-out*. The unit is selected in parameter 006 *Unit for user-defined read-out*.

Motor current [A], parameter 514:

Gives the motor phase current measured as an effective value.

Power [kW], parameter 515:

Gives the present power absorption of the motor in kW.

Power [HP], parameter 516:

Gives the present power absorption of the motor in HP.

Motor voltage, parameter 517:

Gives the voltage fed to the motor.

DC link voltage, parameter 518:

Gives the intermediate circuit voltage of the frequency converter.

Thermal load, motor [%], parameter 519:

Gives the calculated/estimated thermal load on the motor. 100 % is the cut-out limit. See also parameter 117 *Motor thermal protection*.

Thermal protection, VLT [%], parameter 520:

Gives the calculated/estimated thermal load on the frequency converter. 100 % is the cut-out limit.

Digital input, parameter 521:

Gives the signal status of the 8 inputs (16, 17, 18, 19, 27, 29, 32 and 33). Input 16 corresponds to the bit to the extreme left.
'0' = no signal, '1' = signal connected.

Terminal 53, analogue input [V], parameter 522:

Gives the voltage value of the signal on terminal 53.

Terminal 54, analogue input [V], parameter 523:

Gives the voltage value of the signal on terminal 54.

Terminal 60, analogue input [mA], parameter 524:

Gives the current value of the signal on terminal 60.

Pulse reference [Hz], parameter 525:

Gives a pulse frequency in Hz connected to one of the terminals 17 and 29.

External reference, parameter 526:

Gives the sum of external references as a percentage (sum of analog/pulse/serial communication) in

the range from *Minimum reference, Ref_{MIN}* to *Maximum reference, Ref_{MAX}*.

Status word, parameter 527:

Gives the present status word of the frequency converter in Hex.

Heat sink temperature, parameter 528:

Gives the present heat sink temperature of the frequency converter. The cut-out limit is 90 ± 5 °C/41 F, while cutting back in is effected at 60 ± 5 °C/41 F.

Alarm word, parameter 529:

Gives a Hex code for the alarm on the frequency converter. See *Warning words 1+2 and Alarm word*.

Control word, parameter 530:

Gives the present control word of the frequency converter in Hex.

Warning word, parameter 531:

Indicates in Hex whether there is a warning on the frequency converter. See *Warning words 1+2 and Alarm word*.

Extended status word, parameter 532:

Indicates in Hex code whether there is a warning on the frequency converter. See *Warning words 1+2 and Alarm word*.

Relay status, parameter 537:

Indicates in binary code whether the output relays of the frequency converter are triggered or not.

533 Display text 1

(DISPLAY TEXT ARRAY 1)

Value:

Max. 20 characters [XXXXXXXXXXXXXXXXXXXXXX]

Function:

Here, a text of max. 20 characters can be written that will be shown in display line 1, provided *LCP display text* [27] has been selected in parameter 007 *Large display read-out*. Example of display text.

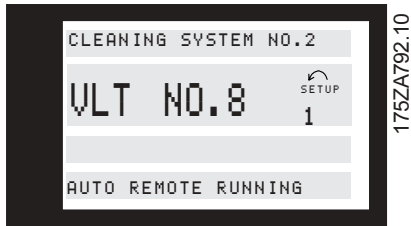

Description of choice:

Write the required text via serial communication.

534 Display text 2

(DISPLAY TEXT ARRAY 2)

Value:

Max. 8 characters [XXXXXXXX]

Function:

Here, a text of max. 8 characters can be written that will be shown in display line 2, provided *LCP display text* [27] has been selected in parameter 007 *Large display read-out*.

Description of choice:

Write the required text via serial communication.

535 Bus feedback 1 Bus feedback 1

(BUS FEEDBACK1)

Value:

0 - 16384 decimal (0 - 4000 Hex) ★ 0

Function:

Via the serial communication port, this parameter allows writing of a bus feedback value which will then form part of the feedback handling (see Feedback handling). Bus feedback 1 will be added to any feedback value registered on terminal 53.

Description of choice:

Write the required bus feedback value via serial communication.

536 Bus feedback 2

(BUS FEEDBACK2)

Value:

0 - 16384 decimal (0 - 4000 Hex) ★ 0

Function:

Via serial communication, a bus feedback value could be written in this parameter that would subsequently become part of the feedback handling system (see *Feedback handling*). Bus feedback 2 will be added to any feedback value on terminal 54.

Description of choice:

Write the required bus feedback value via the serial communication.



NB!:

Parameters 555 *Bus time interval* and 556 *Bus time interval function* are only active when *FC protocol* [0] has been selected in parameter 500 *Protocol*.

555 Bus time interval

(BUS TIME INTERVAL)

Value:

1 - 65534 sec. ★ 60 sec.

Function:

In this parameter, the time is set which is expected to pass as a maximum between the receipt of two telegrams in a row. If this time is exceeded, the serial communication is assumed to have stopped and the required reaction is set in parameter 556 *Bus time interval function*.

Description of choice:

Set the required time.

556 Bus time interval function

(BUS TIME INTERVAL FUNCTION)

Value:

★Off (OFF)	[0]
Freeze output (FREEZE OUTPUT)	[1]
Stop (STOP)	[2]
Jogging (JOG FREQUENCY)	[3]
Max. output frequency (MAX FREQUENCY)	[4]
Stop and trip (STOP AND TRIP)	[5]

Function:

In this parameter, the required reaction from the frequency converter is selected when the time set in parameter 555 *Bus time interval* has been exceeded.

★ = factory setting. () = display text [] = value for use in communication via serial communication port

Description of choice:

The output frequency of the frequency converter can be frozen at the present value at any given time, frozen at parameter 211 *Preset reference 1*, frozen at parameter 202 *Max. output frequency*, or stop and activate a cut-out.

message. The resulting retransmissions of messages will slow communications on the network. If this value is set too long, the drive will wait longer than necessary to determine that the message is completed. This will delay the drive's response to the message and possibly cause the master controller to time out. The resulting retransmissions of messages will slow communications on the network.

570 Modbus parity and message framing

(M.BUS PAR./FRAME)

Value:

(EVEN/1 STOPBIT)	[0]
(ODD/1 STOPBIT)	[1]
★ (NO PARITY/1 STOPBIT)	[2]
(NO PARITY/2 STOPBIT)	[3]

Function:

This parameter sets up the drive's Modbus RTU interface to communicate properly with the master controller. The parity (EVEN, ODD, or NO PARITY) must be set to match the setting of the master controller.

Description of choice:

Select the parity that matches the setting for the Modbus master controller. Even or odd parity is sometimes used to allow a transmitted word to be checked for errors. Because Modbus RTU uses the more efficient CRC (Cyclic Redundancy Check) method of checking for errors, parity checking is seldom used in Modbus RTU networks.

571 Modbus communications timeout

(M.BUS COM.TIME.)

Value:

10 ms - 2000 ms ★ 100 ms

Function:

This parameter determines the maximum amount of time that the drive's Modbus RTU will wait between characters that are sent by the master controller. When this amount of time expires, the drive's Modbus RTU interface will assume that it has received the entire message.

Description of choice:

Generally, the value of 100 ms is sufficient for Modbus RTU networks, although some Modbus RTU networks may operate on a timeout value as short as 35 ms. If this value is set too short, the drive's Modbus RTU interface may miss a part of the message. Since the CRC check will not be valid, the drive will ignore the

★ = factory setting. () = display text [] = value for use in communication via serial communication port

■ Warning words 1+2 and Alarm word

Warning word, extended status word and alarm word are shown in Hex format on the display. If there is more than one warning or alarm, a sum of the total warnings or alarms will be shown. The descriptions relating to the extended status word can be seen from in *Status word as per FC protocol*, and with respect to warning word, extended status word and alarm word, the descriptions can also be read out via the serial bus in parameter 531 *Warning word*, 532 *Extended status word* and 529 *Alarm word*.

Hex code	Extended status word
00000001	Overvoltage control active
00000002	Start delay
00000004	Sleep boost active
00000008	Sleep mode active
00000010	Automatic motor adaptation completed
00000020	Automatic motor adaptation running
00000040	Reversing and start
00000080	Ramp operation
00000100	Reversing
00000200	Speed = reference
00000400	Running
00000800	Local ref. = 0, Remote controlled ref. = 1
00001000	OFF mode = 1
00002000	Auto mode = 0, Hand mode = 1
00004000	Start blocked
00008000	Start blocked signal missing
00010000	Freeze output
00020000	Freeze output blocked
00040000	Jogging
00080000	Jog blocked
00100000	Stand by
00200000	Stop
00400000	DC stop
00800000	Drive ready
01000000	Relay 123 active
02000000	Drive ready
04000000	Control ready
08000000	Start prevented
10000000	Profibus OFF3 active
20000000	Profibus OFF2 active
40000000	Profibus OFF1 active
80000000	Reserved

Hex code	Warning word
00000001	Reference high
00000002	Fault in EEprom on control card
00000004	Fault in EEprom on power card
00000008	HPFB bus timeout
00000010	Serial communication timeout
00000020	Overcurrent
00000040	Current limit
00000080	Motor thermistor
00000100	Motor overtemperature
00000200	Inverter overtemperature
00000400	Undervoltage
00000800	Overvoltage
00001000	Voltage warning low
00002000	Voltage warning high
00004000	Mains failure
00008000	Live zero fault
00010000	Under 10 Volt (terminal 50)
00020000	Reference low
00040000	Feedback high
00080000	Feedback low
00100000	Output current high
00200000	Out of frequency range
00400000	Profibus communication fault
00800000	Output current low
01000000	Output frequency high
02000000	Output frequency low
04000000	AMA - motor too small
08000000	AMA - motor too big
10000000	AMA - check par. 102, 103, 105
20000000	AMA - check par. 102, 104, 106
40000000	Reserved
80000000	Reserved

Bit (Hex)	Alarm word
00000001	Unknown fault
00000002	Trip locked
00000004	Auto-optimisation not OK
00000008	HPFB bus timeout
00000010	Serial communication timeout
00000020	ASIC fault
00000040	HPFP bus timeout
00000080	Standard bus timeout
00000100	Short-circuiting
00000200	Switchmode fault
00000400	Earth fault
00000800	Current limit
00001000	Overcurrent
00002000	Motor thermistor
00004000	Motor overheated
00008000	Inverter overheated
00010000	Undervoltage
00020000	Overvoltage
00040000	Mains failure
00080000	Live zero fault
00100000	Heat sink temperature too high
00200000	Motor phase W missing
00400000	Motor phase V missing
00800000	Motor phase U missing
01000000	Profibus communication fault
02000000	Inverter fault
04000000	Output current low
08000000	Safety stop
10000000	Reserved

■ Service functions 600-631

This parameter group contains functions such as operating data, data log and fault log.

It also has information on the nameplate data of the frequency converter.

These service functions are very useful in connection with operating and fault analysis in an installation.

600-605 Operating data

Value:

Parameter no.	Description	Display text	Unit	Range
Operating data:				
600	Operating hours	(OPERATING HOURS)	Hours	0 - 130,000.0
601	Hours run	(RUNNING HOURS)	Hours	0 - 130,000.0
602	kWh counter	(KWH COUNTER)	kWh	-
603	No. of cut-ins	(POWER UP'S)	Nos.	0 - 9999
604	No. of overtemps.	(OVER TEMP'S)	Nos.	0 - 9999
605	No. of overvoltages	(OVER VOLT'S)	Nos.	0 - 9999

Function:

These parameters can be read out via the serial communication port, as well as via the display in the parameters.

Description of choice:

Parameter 600 *Operating hours:*

Gives the number of hours in which the frequency converter has been in operation. The value is saved every hour and when the power supply to the unit is cut off. This value cannot be reset.

Parameter 601 *Hours run:*

Gives the number of hours in which the motor has been in operation since being reset in parameter 619 *Reset of hours-run counter*. The value is saved every hour and when the power supply to the unit is cut off.

Parameter 602 *kWh counter:*

Gives the output power of the frequency converter. The calculation is based on the mean value in kWh over one hour. This value can be reset using parameter 618 *Reset of kWh counter*.

Parameter 603 *No. of cut-ins:*

Gives the number of cut-ins of supply voltage to the frequency converter.

Parameter 604 *No. of overtemps:*

Gives the number of overtemperature errors on the heat-sink of the frequency converter.

Parameter 605 *No. of overvoltages:*

Gives the number of overvoltages on the intermediate circuit voltage of the frequency converter. The count is only taken when Alarm 7 *Overvoltage* is active.

★ = factory setting. () = display text [] = value for use in communication via serial communication port

606 - 614 Data log

Value:

Parameter no.	Description Data log:	Display text	Unit	Range
606	Digital input	(LOG: DIGITAL INP)	Decimal	0 - 255
607	Control word	(LOG: BUS COMMAND)	Decimal	0 - 65535
608	Status word	(LOG: BUS STAT WD)	Decimal	0 - 65535
609	Reference	(LOG: REFERENCE)	%	0 - 100
610	Feedback	(LOG: FEEDBACK)	Par. 414	-999,999.999 - 999,999.999
611	Output frequency	(LOG: MOTOR FREQ.)	Hz	0.0 - 999.9
612	Output voltage	(LOG: MOTOR VOLT)	Volt	50 - 1000
613	Output current	(LOG: MOTOR CURR.)	Amp	0.0 - 999.9
614	DC link voltage	(LOG: DC LINK VOLT)	Volt	0.0 - 999.9

Function:

With these parameters, it is possible to see up to 20 saved values (data logs) - [1] being the most recent and [20] the oldest log. When a start command has been given, a new entry to the data log is made every 160 ms. If there is a trip or if the motor has stopped, the 20 latest data log entries will be saved and the values will be visible in the display. This is useful, in the case of service after a trip. The data log number is given in square brackets; [1]

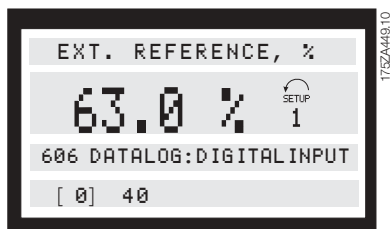

Data logs [1]-[20] can be read by first pressing [CHANGE DATA], followed by the [+/-] keys to change data log numbers. Parameters 606-614 *Data log* can also be read out via the serial communication port.

Description of choice:

Parameter 606 Data log: Digital input:

This is where the latest log data are shown in decimal code, representing the status of the digital inputs. Translated into binary code, terminal 16 corresponds to the bit to the extreme left and to decimal code 128. Terminal 33 corresponds to the bit to the extreme right and to decimal code 1. The table can be used, e.g., for converting a decimal number into a binary code. For example, digital 40 corresponds to binary 00101000. The nearest smaller decimal number is 32, corresponding to a signal on terminal 18. 40-32 = 8, corresponds to the signal on terminal 27.

Terminal	16	17	18	19	27	29	32	33
Decimal number	128	64	32	16	8	4	2	1

Parameter 607 Data log: Control word:

This is where the latest log data are given in decimal code for the control word of the frequency converter. The control word read can only be changed via serial communication. The control work is read as a decimal number which is to be converted into hex.

Parameter 608 Data log: Status word:

This gives the latest log data in decimal code for the status word. The status word is read as a decimal number which is to be converted into hex.

Parameter 609 Data log: Reference:

This gives the latest log data for the resulting reference.

Parameter 610 Data log: Feedback:

This gives the latest log data for the feedback signal.

Parameter 611 Data log: Output frequency:

This gives the latest log data for the output frequency.

Parameter 612 Data log: Output voltage:

This gives the latest log data for the output voltage.

Parameter 613 Data log: Output current:

This gives the latest log data for the output current.

Parameter 614 Data log: DC-link voltage:

This gives the latest log data for the intermediate circuit voltage.

★ = factory setting. () = display text [] = value for use in communication via serial communication port

615 Fault log: Error code

(F. LOG: ERROR CODE)

Value:

[Index 1-10] Error Code: 0 - 99

Function:

This parameter makes it possible to see the reason why a trip (cut-out of the frequency converter) occurs. 10 [1-10] log values are stored.

The lowest log number [1] contains the latest/most recently saved data value; the highest log number [10] contains the oldest data value.

If there is a trip on the frequency converter, it is possible to see its cause, the time and possibly the values for output current or output voltage.

Description of choice:

Stated as an error code in which the number refers to a table in *List of warnings and alarms*.

The fault log is only reset after manual initialization. (See *Manual initialization*).

616 Fault log: Time

(F. LOG: TIME)

Value:

[Index 1-10] Hours: 0 - 130,000.0

Function:

This parameter makes it possible to see the total number of hours run in connection with the 10 latest trips.

10 [1-10] log values are stored. The lowest log number [1] contains the latest/most recently saved data value, while the highest log number [10] contains the oldest data value.

Description of choice:

The fault log is only reset after manual initialization. (See *Manual initialization*).

617 Fault log: Value

(F. LOG: VALUE)

Value:

[Index 1 - 10] Value: 0 - 9999

Function:

This parameter makes it possible to see the value at which a trip occurred. The unit of the value depends on the alarm active in parameter 615 *Fault log: Error code*.

Description of choice:

The fault log is only reset after manual initialization. (See *Manual initialization*).

618 Reset of kWh counter

(RESET KWH COUNT)

Value:

★No reset (DO NOT RESET)	[0]
Reset (RESET COUNTER)	[1]

Function:

Reset to zero of parameter 602 *kWh counter*.

Description of choice:

If Reset [1] has been selected and when the [OK] key is pressed, the kWh counter of the frequency converter is reset. This parameter cannot be selected via the serial port, RS 485.



NB!:

When the [OK] key has been activated, the reset has been carried out.

619 Reset of hours-run counter

(RESET RUN. HOUR)

Value:

★No reset (DO NOT RESET)	[0]
Reset (RESET COUNTER)	[1]

Function:

Reset to zero of parameter 601 *Hours-run*.

Description of choice:

If Reset [1] has been selected and when the [OK] key is pressed, parameter 601 *Hours-run* is reset. This parameter cannot be selected via the serial port, RS 485.



NB!:

When the [OK] key has been activated, the reset has been carried out.

620 Operating mode

(OPERATION MODE)

Value:

★Normal function (NORMAL OPERATION)	[0]
Function with de-activated inverter (OPER. W/INVERT.DISAB)	[1]
Control card test (CONTROL CARD TEST)	[2]
Initialisation (INITIALIZE)	[3]

★ = factory setting. () = display text [] = value for use in communication via serial communication port

Function:

In addition to its normal function, this parameter can be used for two different tests.

Furthermore, it is possible to reset to the default factory settings for all Setups, except parameters 501 *Address*, 502 *Baud rate*, 600-605 *Operating data* and 615-617 *Fault log*.

Description of choice:

Normal function [0] is used for normal operation of the motor.

Function with de-activated inverter [1] is selected if control is desired over the influence of the control signal on the control card and its functions - without the motor shaft running.

Control card [2] is selected if control of the analog and digital inputs, analog and digital outputs, relay outputs and the control voltage of +10 V is desired. A test connector with internal connections is required for this test.

The test connector for the *Control card* [2] is set up as follows:

connect 4-16-17-18-19-27-29-32-33;
 connect 5-12;
 connect 39-20-55;
 connect 42 - 60;
 connect 45-53-54.

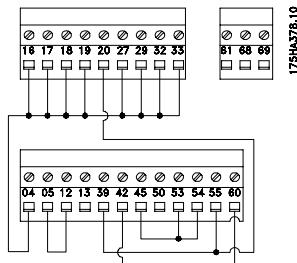

Use the following procedure for the control card test:

1. Select *Control card test*.
2. Cut off the mains supply and wait for the light in the display to go out.
3. Insert the test plug (see preceding column).
4. Connect to mains.
5. The frequency converter expects the [OK] key to be pressed (the test cannot be run without LCP).
6. The frequency converter automatically tests the control card.
7. Remove the test connector and press the [OK] key when the frequency converter displays "TEST COMPLETED".
8. Parameter 620 *Operating mode* is automatically set to Normal function.

If the control card test fails, the frequency converter will display "TEST FAILED". Replace the control card.

★ = factory setting. () = display text [] = value for use in communication via serial communication port

Initialisation [3] is selected if the factory setting of the unit is to be generated without resetting parameters 501 *Address*, 502 *Baud rate*, 600-605 *Operating data* and 615-617 *Fault log*.

Procedure for initialisation:

1. Select *Initialisation*.
2. Press the [OK] key.
3. Cut off the mains supply and wait for the light in the display to go out.
4. Connect to mains.
5. Initialisation of all parameters will be carried out in all Setups with the exception of parameters 501 *Address*, 502 *Baud rate*, 600-605 *Operating data* and 615-617 *Fault log*.

Manual initialisation is another option.(See *Manual initialization*).

621 - 631 Nameplate
Value:

Parameter nr.	Description Nameplate:	Display text
621	Unit type	(DRIVE TYPE)
622	Power component	(POWER SECTION)
623	VLT ordering no.	(ORDERING NO)
624	Software version no.	(SOFTWARE VERSION)
625	LCP identification no.	(LCP ID NO.)
626	Database identification no.	(PARAM DB ID)
627	Power component identification no.	(POWER UNIT DB ID)
628	Application option type	(APPLIC. OPTION)
629	Application option ordering no.	(APPLIC. ORDER NO)
630	Communication option type	(COM. OPTION)
631	Communication option ordering no.	(COM. ORDER NO)

Function:

The main data for the unit can be read from parameters 621 to 631 *Nameplate* via the display or the serial communication port.

Description of choice:
Parameter 621 Nameplate: Unit type:

VLT type gives the unit size and mains voltage. Example: VLT 8008 380-480 V.

Parameter 622 Nameplate: Power component:

This gives the type of power card fitted to the frequency converter. Example: STANDARD.

Parameter 623 Nameplate: VLT ordering no.:

This gives the ordering number for the VLT type in question. Example: 175Z7805.

Parameter 624 Nameplate: Software version no.:

This gives the present software version number of the unit. Example: V 1.00.

Parameter 625 Nameplate: LCP identification no.:

This gives the identification number of the LCP of the unit. Example: ID 1.42 2 kB.

Parameter 626 Nameplate: Database identification no.:

This gives the identification number of the software's database. Example: ID 1.14.

Parameter 627 Nameplate: Power Nameplate: identification no.:

This gives the identification number of the database of the unit. Example: ID 1.15.

Parameter 628 Nameplate: Application option type:

This gives the type of application options fitted with the frequency converter.

Parameter 629 Nameplate: Application option ordering no.:

This gives the ordering number for the application option.

Parameter 630 Nameplate: Communication option type:

This gives the type of communication options fitted with the frequency converter.

Parameter 631 Nameplate: Communication option ordering no.:

This gives the ordering number for the communication option.

★ = factory setting. () = display text [] = value for use in communication via serial communication port



NB!:

Parameters 700-711 for the relay card are only activated if a relay option card is installed in the VLT 8000 AQUA.

- 700 Relay 6, function**
(RELAY6 FUNCTION)
- 703 Relay 7, function**
(RELAY7 FUNCTION)
- 706 Relay 8, function**
(RELAY8 FUNCTION)
- 709 Relay 9, function**
(RELAY9 FUNCTION)

Function:

This output activates a relay switch. Relay outputs 6/7/8/9 can be used for showing status and warnings. The relay is activated when the conditions for the relevant data values have been fulfilled. Relays 6, 7, 8, and 9 can be programmed with the same option as Relay 1. See parameter 323, Relay 1 *Output Functions*, for a description of functions to choose from.

Description of choice:

See data choice and connections in *Relay outputs*.

- 701 Relay 6, ON delay**
(RELAY6 ON DELAY)
- 704 Relay 7, ON delay**
(RELAY7 ON DELAY)
- 707 Relay 8, ON delay**
(RELAY8 ON DELAY)
- 710 Relay 9, ON delay**
(RELAY9 ON DELAY)

Value:
0 - 600 sec. ★ 0 sec.

Function:

This parameter allows a delay of the cut-in time of relays 6/7/8/9 (terminals 1-2).

Description of choice:

Enter the required value.

- 702 Relay 6, OFF delay**
(RELAY6 OFF DELAY)
- 705 Relay 7, OFF delay**
(RELAY7 OFF DELAY)
- 708 Relay 8, OFF delay**
(RELAY8 OFF DELAY)
- 711 Relay 9, OFF delay**
(RELAY9 OFF DELAY)

Value:
0 - 600 sec. ★ 0 sec.

Function:

This parameter is used to delay the cut-out time of relays 6/7/8/9 (terminals 1-2).

Description of choice:

Enter the required value.

■ Electrical installation of the relay card

The relays are connected as shown below.

Relay 6-9:
A-B make, A-C break
Max. 240 V AC, 2 Amp.
Max. cross-section: 1.5 mm² (AWG 28-16)
Torque: 0.22 - 0.25 Nm / 4.5 - 5 In lb
Screw size: M2

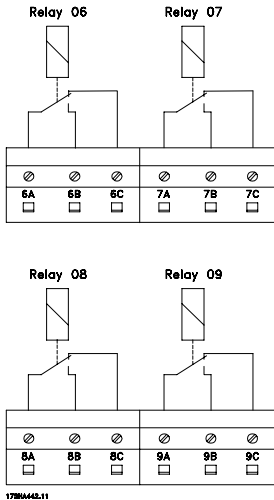

To achieve double isolation, the plastic foil must be mounted as shown in the drawing below.

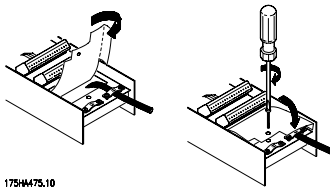

★ = factory setting. () = display text [] = value for use in communication via serial communication port

■ Status messages

Status messages appear in the 4th line of the display - see example below.

The left part of the status line indicates the active type of control of the frequency converter.

The centre part of the status line indicates the active reference.

The last part of the status line gives the present status, e.g. "Running", "Stop" or "Stand by".

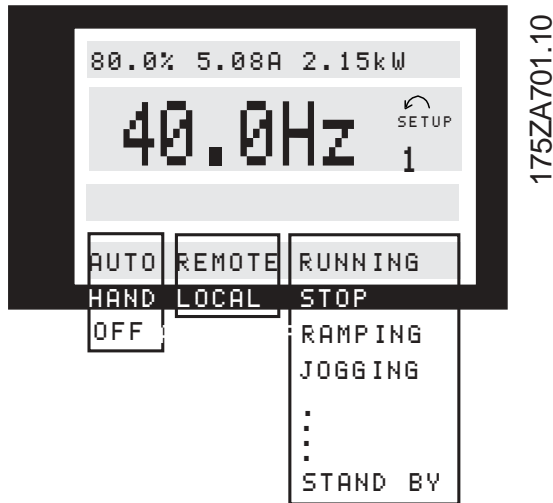

Auto mode (AUTO)

The frequency converter is in Auto mode, i.e. control is carried out via the control terminals and/or serial communication. See also *Auto start*.

Hand mode (HAND)

The frequency converter is in Hand mode, i.e. control is carried out via the control keys. See *Hand start*.

OFF (OFF)

OFF/STOP is activated either by means of the control key, or by the digital inputs *Hand start* and *Auto start* both being a logic "0". See also *OFF/STOP*

Local reference (LOCAL)

If LOCAL has been selected, the reference is set via the [+/-] keys on the control panel. See also *Display modes*.

Remote reference (REM.)

If REMOTE has been selected, the reference is set via the control terminals or via serial communication. See also *Display modes*.

Running (RUNNING)

The motor speed now corresponds to the resulting reference.

Ramp operation (RAMPING)

The output frequency is now changed in accordance with the preset ramps.

Auto-ramp (AUTO RAMP)

Parameter 208 *Automatic ramp-up/down* is enabled, i.e. the frequency converter is trying to avoid a trip from overvoltage by increasing its output frequency.

Sleep Boost (SLEEP .BST)

The boost function in parameter 406 *Boost setpoint* is enabled. This function is only possible in *Closed loop* operation.

Sleep mode (SLEEP)

The energy saving function in parameter 403 *Sleep mode timer* is enabled. This means that at present the motor has stopped, but that it will restart automatically when required.

Start delay (START DEL)

A start delay time has been programmed in parameter 111 *Start delay*. When the delay has passed, the output frequency will start by ramping up to the reference.

Run request (RUN REQ.)

A start command has been given, but the motor will be stopped until a Run permissive signal is received via a digital input.

Jogging (JOG)

Jog has been enabled via a digital input or via serial communication.

Jog request (JOG REQ.)

A JOG command has been given, but the motor will remain stopped until a *Run permissive* signal is received via a digital input.

Freeze output (FRZ.OUT.)

Freeze output has been enabled via a digital input.

Freeze output request (FRZ.REQ.)

A freeze output command has been given, but the motor will remain stopped until a Run permissive signal is received via a digital input.

Reversing and start (START F/R)

Reversing and start [2] on terminal 19 (parameter 303 *Digital inputs*) and *Start* [1] on terminal 18 (parameter 302 *Digital inputs*) are enabled at the

All about VLT 8000 AQUA

same time. The motor will remain stopped until one of the signals becomes a logic '0'.

Automatic Motor Adaptation running (AMA RUN)

Automatic motor adaptation has been enabled in parameter 107 *Automatic Motor Adaptation, AMA*.

Automatic Motor Adaptation completed (AMA STOP)

Automatic motor adaptation has been completed. The frequency converter is now ready for operation after the *Reset* signal has been enabled. Please note that the motor will start after the frequency converter has received the *Reset* signal.

Stand by (STANDBY)

The frequency converter is able to start the motor when a start command is received.

Stop (STOP)

The motor has been stopped via a stop signal from a digital input, [OFF/STOP]-button or serial communication.

DC stop (DC STOP)

The DC brake in parameter 114-116 has been enabled.

DRIVE ready (UN. READY)

The frequency converter is ready for operation, but terminal 27 is a logic "0" and/or a *Coasting command* has been received via the serial communication.

Not ready (NOT READY)

The frequency converter is not ready for operation, because of a trip or because OFF1, OFF2 or OFF3 is a logic '0'.

Start disabled (START IN.)

This status will only be displayed if, in parameter 599 *Statemachine, Profidrive* [1] has been selected and OFF2 or OFF3 is a logic '0'.

Exceptions XXXX (EXCEPTIONS XXXX)

The microprocessor of the control card has stopped and the frequency converter is out of operation. The cause may be noise on the mains, motor or control cables, leading to a stop of the control card microprocessor. Check for EMC-correct connection of these cables.

■ List of warnings and alarms

The table gives the different warnings and alarms and indicates whether the fault locks the frequency converter. After Trip locked, mains supply must be cut and the fault must be corrected. Reconnect mains supply and reset the frequency converter before being ready. A Trip can be reset manually in three ways

1. Via the control key [RESET]
2. Via a digital input
3. Via serial communication

In addition, an automatic reset may be selected in parameter 400 *Reset function*.

Wherever a cross is placed under both Warning and Alarm, this can mean that a warning precedes the alarm. It can also mean that it is possible to program whether a given fault is to result in a warning or an alarm. This is possible, e.g. in parameter 117 *Motor thermal protection*. After a trip, the motor will be coasting and on the frequency converter alarm and warning will flash. If the fault is removed, only the alarm will flash. After a reset, the frequency converter will be ready to start operation again.

No.	Description	Warning	Alarm	Trip locked
1	10 Volts low (10 VOLT LOW)	X		
2	Live zero fault (LIVE ZERO ERROR)	X	X	X
4	Mains imbalance (MAINS IMBALANCE)	X		
5	Voltage warning high (DC LINK VOLTAGE HIGH)	X		
6	Voltage warning low (DC LINK VOLTAGE LOW)	X		
7	Overvoltage (DC LINK OVERVOLT)	X	X	
8	Undervoltage (DC LINK UNDERVOLT)	X	X	
9	Inverter overloaded (INVERTER TIME)	X	X	
10	Motor overloaded (MOTOR TIME)	X	X	
11	Motor thermistor (MOTOR THERMISTOR)	X	X	
12	Current limit (CURRENT LIMIT)	X	X	
13	Overcurrent (OVERCURRENT)	X	X	X
14	Ground fault (GROUND FAULT)		X	X
15	Switch mode fault (SWITCH MODE FAULT)		X	X
16	Short-circuit (CURR.SHORT CIRCUIT)		X	X
17	Serial communication timeout (STD BUSTIMEOUT)	X	X	
18	HPFB bus timeout (HPFB TIMEOUT)	X	X	
19	Fault in EEprom on power card (EE ERROR POWER)	X		
20	Fault in EEprom on control card (EE ERROR CONTROL)	X		
22	Auto-optimisation not OK (AMA FAULT)		X	
29	Heat-sink temperature too high (HEAT SINK OVERTEMP.)		X	X
30	Motor phase U missing (MISSING MOT.PHASE U)		X	
31	Motor phase V missing (MISSING MOT.PHASE V)		X	
32	Motor phase W missing (MISSING MOT.PHASE W)		X	
34	HBFB communication fault (HBFB COMM. FAULT)	X	X	
37	Inverter fault (GATE DRIVE FAULT)		X	X
39	Check parameters 104 and 106 (CHECK P.104 & P.106)	X		
40	Check parameters 103 and 105 (CHECK P.103 & P.106)	X		
41	Motor too big (MOTOR TOO BIG)	X		
42	Motor too small (MOTOR TOO SMALL)	X		
60	Safety stop (EXTERNAL FAULT)		X	
61	Output frequency low (FOUT < FLOW)	X		
62	Output frequency high (FOUT > FHIGH)	X		
63	Output current low (I MOTOR < I LOW)	X	X	
64	Output current high (I MOTOR > I HIGH)	X		
65	Feedback low (FEEDBACK < FDB LOW)	X		
66	Feedback high (FEEDBACK > FDB HIGH)	X		
67	Reference low (REF. < REF. LOW)	X		
68	Reference high (REF. > REF. HIGH)	X		
69	Temperature auto derate (TEMP.AUTO DERATE)	X		
99	Unknown fault (UNKNOWN ALARM)		X	X

■ Warnings

A warning will flash in line 2, while an explanation is given in line 1.

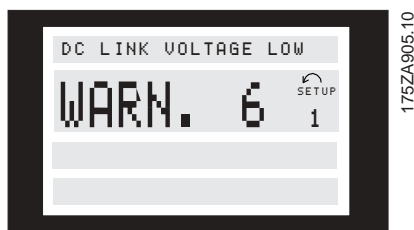

■ Alarms

If an alarm is given, the present alarm number will be shown in line 2. Lines 3 and 4 of the display will offer an explanation.



■ Warnings and alarms

WARNING 1

Under 10 V (10 VOLT LOW)

The 10 V voltage from terminal 50 on the control card is below 10 V.
Remove some of the load from terminal 50, as the 10 Volts supply is overloaded. Max. 17 mA/min. 590 Ω.

WARNING/ALARM 2

Live zero fault (LIVE ZERO ERROR)

The current or voltage signal on terminal 53, 54 or 60 is below 50% of the value preset in parameter 309, 312 and 315 *Terminal, min. scaling*.

WARNING/ALARM 4

Mains imbalance (MAINS IMBALANCE)

High imbalance or phase missing on the supply side.
Check the supply voltage to the frequency converter.

WARNING 5

Voltage warning high (DC LINK VOLTAGE HIGH)

The intermediate circuit voltage (DC) is higher than *Voltage warning high*, see table below. The controls of the frequency converter are still enabled.

WARNING 6

Voltage warning low (DC LINK VOLTAGE LOW)

The intermediate circuit voltage (DC) is lower than *Voltage warning low*, see table below. The controls of the frequency converter are still enabled.

WARNING/ALARM 7

Overvoltage (DC LINK OVERVOLT)

If the intermediate circuit voltage (DC) is higher than the Overvoltage limit of the inverter (see table below), the frequency converter will trip after a fixed period. The length of this period depends on the unit.

Alarm/warning limits:

Alarm/warning limits:	3 x 200 - 240 V	3 x 380 - 480 V	3 x 525 - 600 V	3 x 525 - 690 V
	[VDC]	[VDC]	[VDC]	[VDC]
Undervoltage	211	402	557	553
Voltage warning low	222	423	585	585
Voltage warning high	384	769	943	1084
Overvoltage	425	855	975	1120

The voltages stated are the intermediate circuit voltage of the frequency converter with a tolerance of ± 5 %. The corresponding mains voltage is the intermediate circuit voltage divided by 1.35.

WARNING/ALARM 8

Undervoltage (DC LINK UNDERVOLT)

If the intermediate circuit voltage (DC) drops below the *undervoltage limit* of the inverter, the frequency converter will trip after a fixed period, the length of the period depending on the unit.
Furthermore, the voltage will be stated in the display.
Check whether the supply voltage matches the frequency converter, see *Technical data*.

WARNING/ALARM 9

Inverter overload (INVERTER TIME)

The electronic, thermal inverter protection reports that the frequency converter is about to cut out because of an over-load (too high current for too long). The counter for electronic, thermal inverter protection gives a warning at 98% and trips at 100%, while giving an alarm. The frequency converter cannot be reset until the counter is below 90%.
The fault is that the frequency converter is overloaded by more than 100% for too long.

WARNING/ALARM 10
Motor overtemperature (MOTOR TIME)

According to the electronic thermal protection (ETR), the motor is too hot. Parameter 117 *Motor thermal protection* allows a choice of whether the frequency converter is to give a warning or an alarm when the *Motor thermal projection* reaches 100%. The fault is that the motor is overloaded by more than 100% of the preset, rated motor current for too long. Check that the motor parameters 102-106 have been set correctly.

WARNING/ALARM 11
Motor thermistor (MOTOR THERMISTOR)

The thermistor or the thermistor connection has been disconnected. Parameter 117 *Motor thermal protection* allows a choice of whether the frequency converter is to give a warning or an alarm. Check that the thermistor has been correctly connected between terminal 53 or 54 (analog voltage input) and terminal 50 (+ 10 V supply).

WARNING/ALARM 12
Current limit (CURRENT LIMIT)

The current is higher than the value in parameter 215 *Current limit* I_{LIM} and the frequency converter trips after the time set in parameter 412 *Trip delay overcurrent*, I_{LIM} has passed.

WARNING/ALARM 13
Overcurrent (OVER CURRENT)

The inverter peak current limit (approx. 200% of the rated current) has been exceeded. The warning will last approx. 1-2 seconds, following which the frequency converter will trip and give off an alarm. Turn off the frequency converter and check whether the motor shaft can be turned and whether the motor size matches the frequency converter.

ALARM: 14
Ground fault (GROUND FAULT)(GROUND FAULT)

There is a discharge from the output phases to ground, either in the cable between the frequency converter and the motor or in the motor itself. Turn off the frequency converter and remove the earth fault.

ALARM: 15
Switch mode fault (SWITCH MODE FAULT)

Fault in the switch mode power supply (internal ± 15 V supply).
Contact your Danfoss supplier.

ALARM: 16
Short-circuiting (CURR. SHORT CIRCUIT)

There is short-circuiting on the motor terminals or in the motor itself.

Cut off the mains supply to the frequency converter and remove the short-circuit.

WARNING/ALARM 17
Serial communication timeout (STD BUSTIMEOUT)

There is no serial communication with the frequency converter. This warning will only be enabled if parameter 556 *Bus time interval function* has been set to a value different from OFF.
If parameter 556 *Bus time interval function* has been set to Stop and trip [5], the frequency converter will first give off an alarm, then ramp down and finally trip while giving off an alarm. It is possible to increase parameter 555 *Bus time interval*.

WARNING/ALARM 18
HPFB bus timeout (HPFB TIMEOUT)

There is no serial communication with the communication option card of the frequency converter. The warning will only be enabled if parameter 804 *Bus time interval function* has been set to anything but OFF. If parameter 804 *Bus time interval function* has been set to *Stop and trip*, the frequency converter will first give off an alarm, then ramp down and finally trip while giving off an alarm.
Parameter 803 *Bus time interval* could possibly be increased.

WARNING 19
Fault in the EEPROM on the power card (EE ERROR POWER)

There is a fault on the power card EEPROM. The frequency converter will continue to function, but is likely to fail at the next power-up. Contact your Danfoss supplier.

WARNING 20
Fault in the EEPROM on the control card (EE ERROR CONTROL)

There is a fault in the EEPROM on the control card. The frequency converter will continue to function, but is likely to fail at the next power-up. Contact your Danfoss supplier.

ALARM: 22
Auto-optimisation not OK (AMA FAULT)

A fault has been found during automatic motor adaptation. The text shown in the display indicates a fault message.

NB!:

AMA can only be carried out if there are no alarms during tuning.

CHECK 103, 105 [0]

Parameter 103 or 105 has a wrong setting. Correct the setting and start AMA all over.

LOW P.105 [1]

The motor is too small for AMA to be carried out. If AMA is to be enabled, the rated motor current (parameter 105) must be higher than 35% of the rated output current of the frequency converter.

ASYMMETRICAL IMPEDANCE [2]

AMA has detected an asymmetrical impedance in the motor connected to the system. The motor could be defective.

MOTOR TOO BIG [3]

The motor connected to the system is too big for AMA to be carried out. The setting in parameter 102 does not match the motor used.

MOTOR TOO SMALL [4]

The motor connected to the system is too small for AMA to be carried out. The setting in parameter 102 does not match the motor used.

TIME OUT [5]

AMA fails because of noisy measuring signals. Try to start AMA all over a number of times, until AMA is carried out. Please note that repeated AMA runs may heat the motor to a level where the stator resistance RS is increased. In most cases, however, this is not critical.

INTERRUPTED BY USER [6]

AMA has been interrupted by the user.

INTERNAL FAULT [7]

An internal fault has occurred in the frequency converter. Contact your Danfoss supplier.

LIMIT VALUE FAULT [8]

The parameter values found for the motor are outside the acceptable range within which the frequency converter is able to work.

MOTOR ROTATES [9]

The motor shaft rotates. Make sure that the load is not able to make the motor shaft rotate. Then start AMA all over.

ALARM 29**Heat sink temperature too high (HEAT SINK OVER TEMP.):**

If the enclosure is Chassis or NEMA 1, the cut-out temperature of the heat-sink is 90°C. If NEMA 12 is used, the cut-out temperature is 80°C.

The tolerance is $\pm 5^\circ\text{C}$. The temperature fault cannot be reset, until the temperature of the heat-sink is below 60°C.

The fault could be the following:

- Ambient temperature too high
- Too long motor cable
- Too high switching frequency.

ALARM: 30**Motor phase U missing (MISSING MOT.PHASE U):**

Motor phase U between frequency converter and motor is missing.

Turn off the frequency converter and check motor phase U.

ALARM: 31**Motor phase V missing (MISSING MOT.PHASE V):**

Motor phase V between frequency converter and motor is missing.

Turn off the frequency converter and check motor phase V.

ALARM: 32**Motor phase W missing (MISSING MOT.PHASE U):**

Motor phase W between frequency converter and motor is missing.

Turn off the frequency converter and check motor phase W.

WARNING/ALARM: 34**HPFB communication fault (HPFB COMM. FAULT)**

The serial communication on the communication option card is not working.

ALARM: 37**Inverter fault (GATE DRIVE FAULT):**

IGBT or the power card is defective. Contact your Danfoss supplier.

Auto-optimization warnings 39-42

Automatic motor adaptation has stopped, since some parameters have probably been set wrongly, or the motor used is too big/small for AMA to be carried out. A choice must thus be made by pressing [CHANGE DATA] and choosing "Continue" + [OK] or "Stop" + [OK].

If parameters need to be changed, select "Stop"; start up AMA all over.

WARNING: 39
CHECK PAR. 104, 106

Parameters 104 *Motor frequency* $f_{M,N}$, or 106 *Rated motor speed* $n_{M,N}$, have probably not been set correctly. Check the setting and select "Continue" or [STOP].

WARNING: 40
CHECK PAR. 103, 105

Parameter 103 *Motor voltage*, $U_{M,N}$ or 105 *Motor current*, $I_{M,N}$ has not been set correctly. Correct the setting and restart AMA.

WARNING: 41
MOTOR TOO BIG (MOTOR TOO BIG)

The motor used is probably too big for AMA to be carried out. The setting in parameter 102 *Motor power*, $P_{M,N}$ may not match the motor. Check the motor and choose 'Continue' or [STOP].

WARNING: 42
MOTOR TOO SMALL (MOTOR TOO SMALL)

The motor used is probably too small for AMA to be carried out. The setting in parameter 102 *Motor power*, $P_{M,N}$ may not match the motor. Check the motor and select "Continue" or [STOP].

ALARM: 60
Safety stop (EXTERNAL FAULT)

Terminal 27 (parameter 304 *Digital inputs*) has been programmed for a *Safety interlock* [3] and is a logic "0".

WARNING: 61
Output frequency low (FOUT < FLOW)

The output frequency is lower than parameter 223 *Warning: Low frequency*, f_{LOW} .

WARNING: 62
Output frequency high (FOUT > FHIGH)

The output frequency is higher than parameter 224 *Warning: High frequency*, f_{HIGH} .

WARNING/ALARM: 63
Output current low (I MOTOR < I LOW)

The output current is lower than parameter 221 *Warning: Low current*, I_{LOW} . Select the required function in parameter 409 *Function in case of no load*.

WARNING: 64
Output current high (I MOTOR > I HIGH)

The output current is higher than parameter 222 *Warning: High current*, I_{HIGH} .

WARNING: 65
Feedback low (FEEDBACK < FDB LOW)

The resulting feedback value is lower than parameter 227 *Warning: Low feedback*, FB_{LOW} .

WARNING: 66
Feedback high (FEEDBACK > FDB HIGH)

The resulting feedback value is higher than parameter 228 *Warning: High feedback*, FB_{HIGH} .

WARNING: 67
Remote reference low (REF. < REF LOW)

The remote reference is lower than parameter 225 *Warning: Low reference*, REF_{LOW} .

WARNING: 68
Remote reference high (REF. > REF HIGH)

The remote reference is higher than parameter 226 *Warning: High reference*, REF_{HIGH} .

WARNING: 69
Temperature auto derate (TEMP.AUTO DERATE)

The heat sink temperature has exceeded the maximum value and the auto derating function (par. 411) is active. *Warning: Temp. Auto derate*.

WARNING: 99
Unknown fault (UNKNOWN ALARM)

An unknown fault has occurred that cannot be processed by the software. Contact your Danfoss supplier.

■ Special conditions

■ Aggressive environments

In common with all electronic equipment, a frequency converter contains a large number of mechanical and electronic components, all of which are vulnerable to environmental effects to some extent.



The frequency converter should not therefore be installed in environments with airborne liquids, particles or gasses capable of affecting and damaging the electronic components. Failure to take the necessary protective measures increases the risk of stoppages, thus reducing the life of the frequency converter.

Liquids can be carried through the air and condense in the frequency converter. In addition to this, liquids may cause corrosion of components and metal parts. Steam, oil and salt water may cause corrosion of components and metal parts. In such environments, equipment with enclosure rating IP54/NEMA 12 is recommended.

Airborne particles such as dust particles may cause mechanical, electrical or thermal failure in the frequency converter.

A typical indicator of excessive levels of airborne particles is dust particles around the frequency converter fan. In very dusty environments, equipment with enclosure rating IP54/NEMA 12 or a cabinet for IP00/Chassis and IP20/NEMA 1 equipment is recommended.

In environments with high temperatures and humidity, corrosive gasses such as sulphur, nitrogen and chlorine compounds will cause chemical processes on the frequency converter components. Such chemical reactions will rapidly affect and damage the electronic components.

In such environments, it is recommended that equipment is mounted in a cabinet with fresh air ventilation, keeping aggressive gases away from the frequency converter.



NB!:

Mounting frequency converter in aggressive environments will increase the risk of stoppages and furthermore considerably reduce the life of the drive.

Before the installation of the frequency converter, the ambient air should be checked for liquids, particles and gasses. This may be done by observing existing installations in this environment. Typical indicators of harmful airborne liquids are water or oil on metal parts, or corrosion of metal parts.

Excessive dust particle levels are often found on installation cabinets and existing electrical installations. One indicator of aggressive airborne gasses is blackening of copper rails and cable ends on existing installations.

■ Calculation of resulting reference

The calculation made below gives the resulting reference when parameter 210 *Reference type* is programmed for *Sum* [0] and *Relative* [1], respectively.

External reference is the sum of references from terminals 53, 54, 60 and serial communication. The sum of these can never exceed parameter 205 *Max. reference*. External reference can be calculated as follows:

$$\begin{aligned} \text{Ext. ref.} &= \frac{(\text{Par. 205 Max. ref.} - \text{Par. 204 Min. ref.}) \times \text{Ana. signal Term. 53 [V]}}{\text{Par. 310 Term. 53 Max. scaling} - \text{Par. 309 Term. 53 Min. scaling}} + \frac{(\text{Par. 205 Max. ref.} - \text{Par. 204 Min. ref.}) \times \text{Ana. signal Term. 54 [V]}}{\text{Par. 313 Term. 54 Max. scaling} - \text{Par. 312 Term. 54 Min. scaling}} + \\ &+ \frac{(\text{Par. 205 Max. ref.} - \text{Par. 204 Min. ref.}) \times \text{Par. 314 Term. 60 [mA]}}{\text{Par. 316 Term. 60 Max. scaling} - \text{Par. 315 Term. 60 Min. scaling}} + \frac{\text{serial com. reference} \times (\text{Par. 205 Max. ref.} - \text{Par. 204 Min. ref.})}{16384 \text{ (4000 Hex)}} \end{aligned}$$

Par. 210 *Reference type* is programmed = *Sum* [0].

$$\text{Res. ref.} = \frac{(\text{Par. 205 Max. ref.} - \text{Par. 204 Min. ref.}) \times \text{Par. 211-214 Preset ref.}}{100} + \text{External ref.} + \text{Par. 204 Min. ref.} + \text{Par. 418/419 Setpoint}$$

(only in closed loop)

Par. 210 *Reference type* is programmed = *Relative* [1].

$$\text{Res.ref.} = \frac{\text{External reference} \times \text{Par. 211-214 Preset ref.}}{100} + \text{Par. 204 Min. ref.} + \text{Par. 418/419 Setpoint (only in closed loop)}$$

■ Galvanic isolation (PELV)*

PELV offers protection by way of extra low voltage. Protection against electric shock is considered to be ensured when the electrical supply is of the PELV type and the installation is made as described in local/national regulations on PELV supplies.

In VLT 8000 AQUA all control terminals as well as terminals 1-3 (AUX relay) are supplied from or in connection with extra low voltage (PELV).

Galvanic (ensured) isolation is obtained by fulfilling requirements concerning higher isolation and by providing the relevant creepage/clearance distances. These requirements are described in the EN 50178 standard.

The components that make up the electrical isolation, as described below, also comply with the requirements concerning higher isolation and the relevant test as described in EN 50178.

The galvanic isolation can be shown in three locations (see drawing below), namely:

1. Power supply (SMPS) incl. signal isolation of U_{DC} , indicating the intermediate current voltage.
2. Gate drive that runs the IGBTs (trigger transformers/opto-couplers).
3. Current transducers (Hall effect current transducers).

*) 525-600 V units do not meet PELV requirements.

A motor thermistor connected to terminals 53/54 must be double isolated to obtain PELV.

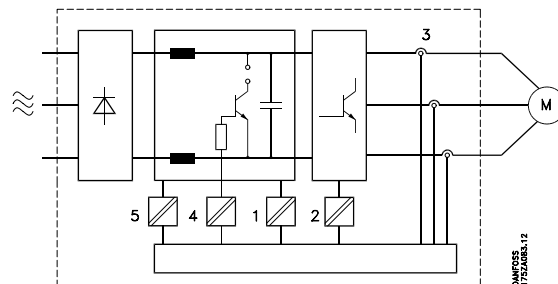

■ Earth leakage current

Earth leakage current is primarily caused by the capacitance between motor phases and the motor cable screen. See drawing on the following page. The size of the leakage current to the earth depends on the following factors, in order of priority:

1. Length of motor cable
2. Motor cable with or without screen
3. Switching frequency
4. RFI filter used or not
5. Motor earthed on site or not

The leakage current is of importance to safety during handling/operation of the frequency converter if (by mistake) the frequency converter has not been earthed.



**NB!:
RCD**

Since the leakage current is > 3.5 mA, reinforced earthing/grounding must be established, which is required if EN 50178 is to be complied with. Never use ELCB relays (type A) that are not suitable for DC fault currents from three-phase rectifier loads.

If ELCB relays are used, they must be:

- Suitable for protecting equipment with a direct current content (DC) in the fault current (3-phase bridge rectifier)
- Suitable for power-up with short pulse-shaped charging current to earth
- Suitable for a high leakage current (300 mA)

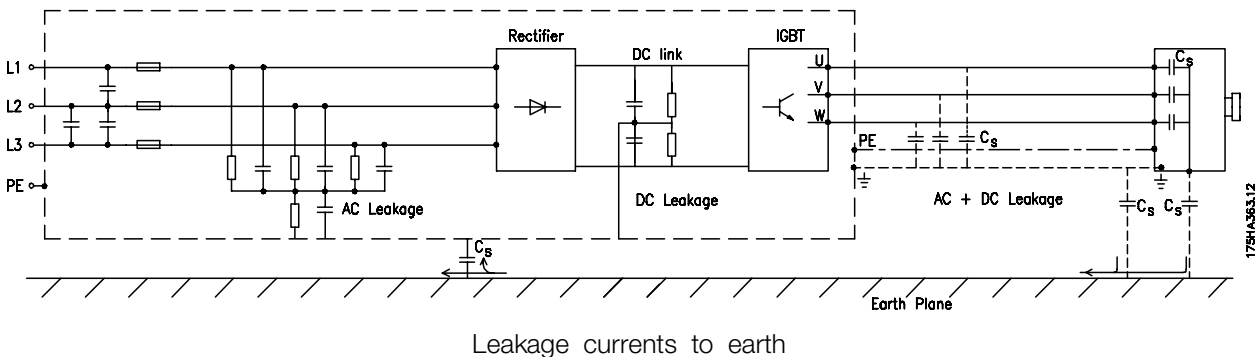

■ Extreme running conditionsShort circuit

VLT 8000 AQUA is protected against short circuits by means of current measurement in each of the three motor phases. A short circuit between two output phases will cause an overcurrent in the inverter. However, each transistor of the inverter will be turned off individually when the short circuit current exceeds the permitted value.

After 5-10 ms the driver card turns off the inverter and the frequency converter will display a fault code, although depending on impedance and motor frequency.

Earth fault

The inverter cuts out within 100 ms in case of an earth fault on a motor phase, although depending on impedance and motor frequency.

Switching on the output

Switching on the output between the motor and the frequency converter is fully permitted. It is not possible to damage VLT 8000 AQUA in any way by switching on the output. However, fault messages may appear.

Motor-generated overvoltage

The voltage in the intermediate circuit is increased when the motor acts as a generator. This occurs in two cases:

1. The load drives the motor (at constant output frequency from the frequency converter), i.e. the load generates energy.
2. During deceleration ("ramp-down") if the moment of inertia is high, the load is low and the ramp-down time is too short for the energy to be dissipated as a loss in the frequency converter, the motor and the installation.

The control unit attempts to correct the ramp if possible. The inverter turns off to protect the transistors and the intermediate circuit capacitors when a certain voltage level is reached.

Mains drop-out

During a mains drop-out, VLT 8000 AQUA continues until the intermediate circuit voltage drops below the minimum stop level, which is typically 15% below VLT 8000 AQUA's lowest rated supply voltage.

The time before the inverter stops depends on the mains voltage before the drop-out and on the motor load.

Static overload

When VLT 8000 AQUA is overloaded (the current limit in parameter 215 *Current limit*, I_{LIM} has been reached), the controls will reduce the output frequency in an attempt to reduce the load.

If the overload is excessive, a current may occur that makes the frequency converter cut out after approx. 1.5 sec.

Operation within the current limit can be limited in time (0- 60 s) in parameter 412 *Trip delay overcurrent*, I_{LIM} .

■ Peak voltage on motor

When a transistor in the inverter is opened, the voltage across the motor increases by a dU/dt ratio that depends on:

- the motor cable (type, cross-section, length screened or unscreened)
- inductance

The natural induction causes an overshoot U_{PEAK} in the motor voltage before it stabilises itself at a level which depends on the voltage in the intermediate circuit. The rise time and the peak voltage U_{PEAK} affect the service life of the motor. If the peak voltage is too high, motors without phase coil insulation are the ones that will primarily be affected. If the motor cable is short (a few metres), the rise time and peak voltage are lower. If the motor cable is long (100 m), the rise time and peak voltage will increase.

If very small motors are used without phase coil insulation, it is recommended to fit a LC filter after the frequency converter. Typical values for the rise time and peak voltage U_{PEAK} are measured on the motor terminals between two phases.

To obtain approximate values for cable lengths and voltages not mentioned below, use the following rules of thumb:

1. Rise time increases/decreases proportionally with cable length.
2. $U_{PEAK} = \text{DC link voltage} \times 1.9$
(DC link voltage = Mains voltage \times 1.35).

$$3. \frac{dU}{dt} = \frac{0.8 \times U_{PEAK}}{\text{Rise time}}$$

Data are measured according to IEC 60034-17. Cable lengths are in metres/feet.

VLT 8006-8011 / 380-480 V

Cable length	Mains		Peak voltage	dU/dt
	volt-age	Rise time		
50m/164ft	500 V	0.5 μ sec.	1230 V	1968 V/ μ sec.
150m/492ft	500 V	1 μ sec.	1270 V	1270 V/ μ sec.
50m/164ft	380 V	0.6 μ sec.	1000 V	1333 V/ μ sec.
150m/492ft	380 V	1.33 μ sec.	1000 V	602 V/ μ sec.

VLT 8016-8122 / 380-480 V

Cable length	Mains		Peak voltage	dU/dt
	volt-age	Rise time		
32m/105ft	380 V	0.27 μ sec.	950 V	2794 V/ μ sec.
70m/230ft	380 V	0.60 μ sec.	950 V	1267 V/ μ sec.
132m/433ft	380 V	1.11 μ sec.	950 V	685 V/ μ sec.

VLT 8152-8352 / 380-480 V

Cable length	Mains		Peak voltage	dU/dt
	volt-age	Rise time		
70m/230ft	400 V	0.34 μ sec.	1040 V	2447 V/ μ sec.

VLT 8450-8600 / 380-480 V

Cable length	Mains		Peak voltage	dU/dt
	voltage	Rise time		
20m/66ft	460 V	1.41 μ sec.	730 V	415 V/ μ sec.

VLT 8002-8011 / 525-600 V

Cable length	Mains		Peak voltage	dU/dt
	volt-age	Rise time		
35m/115ft	600 V	0.36 μ sec.	1360 V	3022 V/ μ sec.

VLT 8016-8072 / 525-600 V

Cable length	Mains		Peak voltage	dU/dt
	volt-age	Rise time		
35m/115ft	575 V	0.38 μ sec.	1430 V	3011 V/ μ sec.

VLT 8052-8402 / 525-690 V

Cable length	Mains		Peak voltage	dU/dt
	voltage	Rise time		
25m/82ft	690 V	0.59 μ sec.	1425 V	1983 V/ μ sec.
25m/82ft	575 V	0.66 μ sec.	1159 V	1428 V/ μ sec.
25m/82ft	690 V ¹⁾	1.72 μ sec.	1329 V	640 V/ μ sec.

1) With Danfoss dU/dt filter.

■ Acoustic noise

The acoustic interference from the frequency converter comes from two sources:

1. DC intermediate circuit coils
2. Integral fan.

Below are the typical values measured at a distance of 1 meter/3 feet from the unit at full load:

VLT 8006-200 V, VLT 8006-8011 400 V

IP20/NEMA 1 units:	50 dB(A)
IP54/NEMA 12 units:	62 dB(A)

VLT 8008-8027 200 V, VLT 8016-8122 400 V

IP20/NEMA 1 units:	61 dB(A)
IP54/NEMA 12 units:	66 dB(A)

VLT 8042-8062 200-240 V

IP20/NEMA 1 units:	70 dB(A)
IP54/NEMA 12 units:	65 dB(A)

VLT 8152-8352 380-480 V

IP00/Chassis/IP21/NEMA 1/IP54/NEMA 12 units:	74 dB(A)
--	----------

VLT 8450-8600 380-480 V

IP00/Chassis units:	71 dB(A)
IP20/NEMA 1/IP54/NEMA 12	82 dB(A)

VLT 8002-8011 525-600 V

IP20/NEMA 1 units:	62 dB(A)
--------------------	----------

VLT 8016-8072 525-600 V

IP20/NEMA 1 units:	66 dB(A)
--------------------	----------

VLT 8052-8402 525-690 V

IP20/NEMA 1/IP54 units:	74 dB(A)
-------------------------	----------

Derating for ambient temperature

The ambient temperature ($T_{AMB,MAX}$) is the maximum temperature allowed. The average ($T_{AMB,MAX}$) measured over 24 hours must be at least 5°C (9°F) lower.

If VLT 8000 AQUA is operated at temperatures above 45°C (113°F), a derating of the continuous output current is necessary.

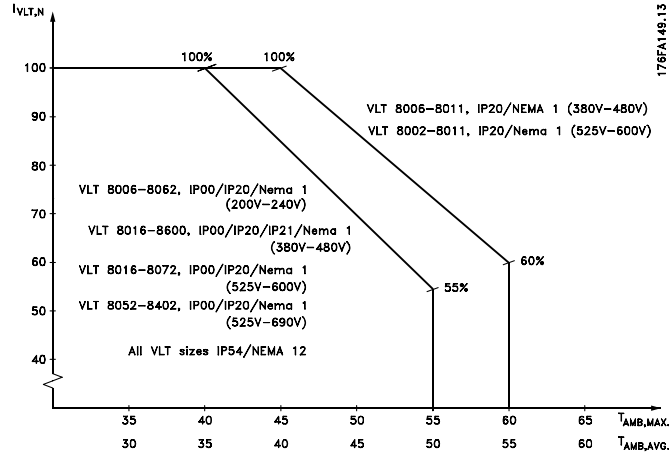

The current of VLT 8152-8352, 380-480 V, is to be derated 1%/°C above 40°C maximum.

Derating for air pressure

Below 1000m/3300 ft altitude no derating is necessary.

Above 1000m/3300 ft the ambient temperature (T_{AMB}) or max. output current ($I_{VLT,MAX}$) must be derated in accordance with the diagram below:

1. Derating of output current versus altitude at $T_{AMB} = \max. 40^{\circ}\text{C}$ (113°F)
2. Derating of max. T_{AMB} versus altitude at 100% output current.

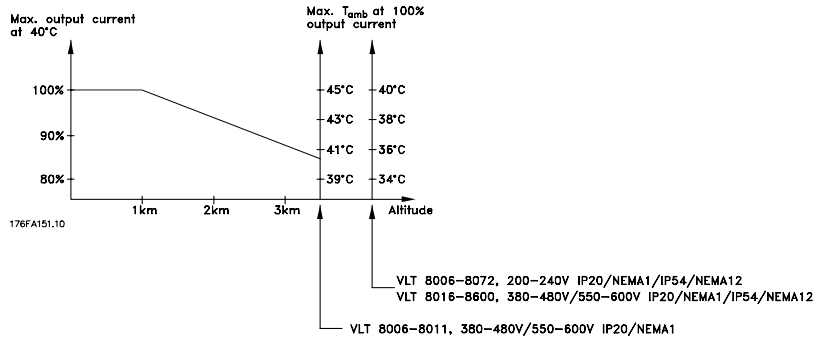

Switching on the input

Switching on the input depends on the mains voltage in question.

The table states the waiting time between cut-ins.

Mains voltage	380 V	415 V	460 V
Waiting time	48 s	65 s	89 s

■ Derating for running at low speed

When a centrifugal pump or a fan is controlled by a VLT 8000 AQUA frequency converter, it is not necessary to reduce the output current at low speed because the load characteristic of the centrifugal pumps/fans, automatically ensures the necessary reduction.

For CT (Constant Torque) applications, consult motor manufacturer for motor derating guideline based upon operating load and duty cycle.

Switching frequency [kHz]	Min.	Max.	Fact.
VLT 8006-8032, 200 V	3.0	14.0	4.5
VLT 8042-8062, 200 V	3.0	4.5	4.5
VLT 8006-8011, 480 V	3.0	10.0	4.5
VLT 8016-8062, 480 V	3.0	14.0	4.5
VLT 8072-8122, 480 V	3.0	4.5	4.5
VLT 8152-8352, 480 V	4.5	4.5	4.5
VLT 8450-8600 480 V	3.0	4.5	4.5
VLT 8002-8011, 600 V	4.5	7.0	4.5
VLT 8016-8032, 600 V	3.0	14.0	4.5
VLT 8042-8062, 600 V	3.0	10.0	4.5
VLT 8072, 600 V	3.0	4.5	4.5
VLT 8052-8352, 690 V	1.5	3.0	3.0
VLT 8402, 690 V	1.5	2.0	2.0

■ Derating for long motor cables or cables with larger cross-section

VLT 8000 AQUA has been tested using 300m (1000 ft) unscreened/unarmoured cable and 150m (~500 feet) screened/armoured cable.

VLT 8000 AQUA has been designed to work using a motor cable with a rated cross-section. Using motor cables with cross-section area greater than required for rated motor amps can increase cable capacitive leakage current to earth (ground). Total output current (motor amps + leakage amps) must not be allowed to exceed the rated frequency converter output current value.

■ Derating for high switching frequency

A higher switching frequency (to be set in parameter 407 - *Switching frequency*) leads to higher losses in the electronics of the frequency converter.

VLT 8000 AQUA has a pulse pattern in which it is possible to set the switching frequency from 3.0- 10.0/14.0 kHz.

The frequency converter will automatically derate the rated output current $I_{VLT,N}$, when the switching frequency exceeds 4.5 kHz.

In both cases, the reduction is carried out linearly, down to 60% of $I_{VLT,N}$.

The table gives the min., max. and factory-set switching frequencies for VLT 8000 AQUA units.

■ Motor thermal protection

The motor temperature is calculated on the basis of motor current, output frequency and time. See parameter 117, *Motor thermal protection*.

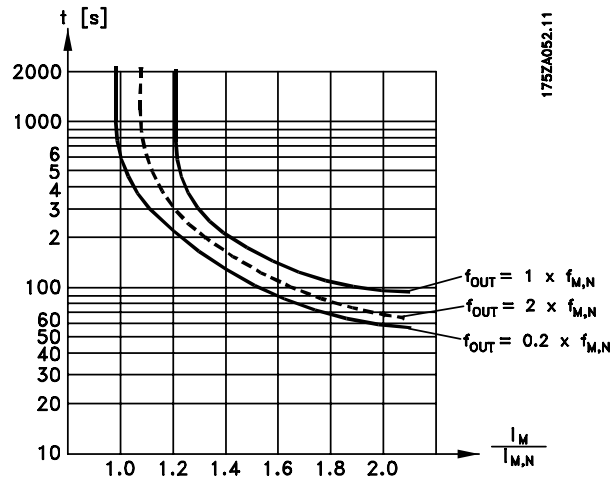

■ Vibration and shock

VLT 8000 AQUA has been tested according to a procedure based on the following standards:

IEC 68-2-6:	Vibration (sinusoidal) - 1970
IEC 68-2-34:	Random vibration broad-band - general requirements
IEC 68-2-35:	Random vibration broad-band - high reproducibility
IEC 68-2-36:	Random vibration broad-band - medium reproducibility

VLT 8000 AQUA complies with requirements that correspond to conditions when the unit is mounted on the walls and floors of production premises, as well as in panels bolted to walls or floors.

■ Air humidity

VLT 8000 AQUA has been designed to meet the IEC 68-2-3 standard, EN 50178 pkt. 9.4.2.2/DIN 40040, class E, at 40°C.

See specifications under *General technical data*.

■ Efficiency

To reduce energy consumption it is very important to optimize the efficiency of a system. The

efficiency of each single element in the system should be as high as possible.

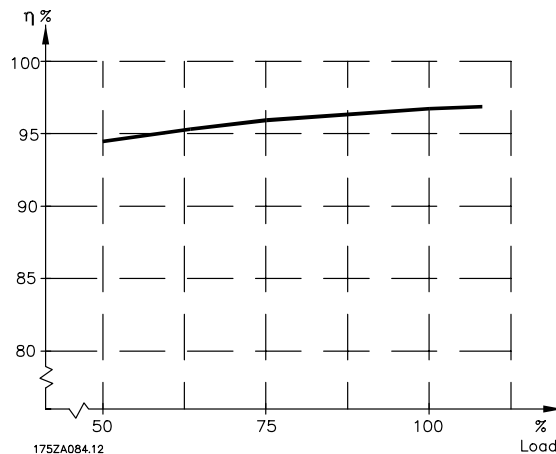

Efficiency of VLT 8000 AQUA (η_{VLT})

The load on the frequency converter has little effect on its efficiency. In general, the efficiency is the same at the rated motor frequency $f_{M,N}$, regardless of whether the motor supplies 100% of the rated shaft torque or only 75%, i.e. in case of part loads.

The efficiency declines a little when the switching frequency is set to a value of above 4 kHz (parameter 407 *Switching frequency*).

Efficiency of the motor (η_{MOTOR})

The efficiency of a motor connected to the frequency converter depends on the sine shape of the current. In general, the efficiency is just as good as with mains operation. The efficiency of the motor depends on the type of motor.

In the range of 75-100% of the rated torque, the efficiency of the motor is practically constant, both when it is controlled by the frequency converter and when it runs directly on mains.

In small motors, the influence from the U/f characteristic on efficiency is marginal; however, in motors from 15 HP and up, the advantages are significant.

In general, the switching frequency does not affect the efficiency of small motors. Motors from 15 HP

and up have their efficiency improved (1-2%). This is because the sine shape of the motor current is almost perfect at high switching frequency.

Efficiency of the system (η_{SYSTEM})

To calculate the system efficiency, the efficiency of VLT 8000 AQUA (VLT) is multiplied by the efficiency of the motor (η_{MOTOR}):

$$\eta_{SYSTEM} = \eta_{VLT} \times \eta_{MOTOR}$$

Based on the graph outlined above, it is possible to calculate the system efficiency at different speeds.

■ Mains supply interference/harmonics

A frequency converter takes up a non-sinusoidal current from mains, which increases the input current I_{RMS} . A non-sinusoidal current can be transformed by means of a Fourier analysis and split up into sine wave currents with different frequencies, i.e. different harmonic currents I_N with 50 Hz as the basic frequency:

Harmonic currents	I_1	I_5	I_7
Hz	50 Hz	250 Hz	350 Hz

The harmonics do not affect the power consumption directly, but increase the heat losses in the installation (transformer, cables). Consequently, in plants with a rather high percentage of rectifier load, it is important to maintain harmonic currents at a low level to avoid overload of the transformer and high temperature in the cables.

Harmonic currents compared to the RMS input current:

	Input current
I_{RMS}	1.0
I_1	0.9
I_5	0.4
I_7	0.3
I_{11-49}	<0.1

To ensure low, harmonic currents, VLT 8000 AQUA has intermediate circuit coils as standard. This normally reduces the input current I_{RMS} by 40%, down to 40-45% THiD.

In some cases, there is a need for further suppression (e.g. retrofit with frequency converters). For this purpose Danfoss can offer two advanced harmonic filters AHF05 and AHF10, bringing the harmonic current down to around 5% and 10% respectively. For further details, see the operating instructions MG.80.BX.YY. For calculation of harmonic, Danfoss offers the software tool MCT31.

Some of the harmonic currents might disturb communication equipment connected to the same transformer or cause resonance in connection with power-factor correction batteries. VLT 8000 AQUA has been designed in accordance with the following standards:

- IEC 1000-3-2
- IEEE 519-1992
- IEC 22G/WG4
- EN 50178
- VDE 160, 5.3.1.1.2

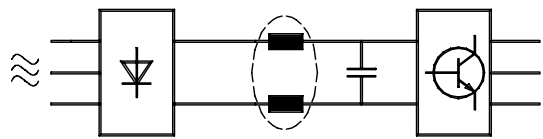

The voltage distortion on the mains supply depends on the size of the harmonic currents multiplied by the mains impedance for the frequency in question. The total voltage distortion THD is calculated on the basis of the individual voltage harmonics using the following formula:

$$THD\% = \frac{\sqrt{U_3^2 + U_7^2 + \dots + U_N^2}}{U_1} \quad (U_N\% \text{ of } U)$$

■ Power factor

The power factor is the relation between I_1 and I_{RMS} .

The power factor for 3-phase control

$$= \frac{\sqrt{3} \times U \times I_1 \times \cos \varphi_1}{\sqrt{3} \times U \times I_{RMS}}$$

$$\text{Power factor} = \frac{I_1 \times \cos \varphi_1}{I_{RMS}} = \frac{I_1}{I_{RMS}} \quad \text{since } \cos \varphi = 1$$

The power factor indicates the extent to which the frequency converter imposes a load on the mains supply.

The lower the power factor, the higher the I_{RMS} for the same kW performance.

In addition, a high power factor indicates that the different harmonic currents are low.

$$I_{RMS} = \sqrt{I_1^2 + I_3^2 + I_7^2 + \dots + I_n^2}$$

■ CE labelling

What is CE labelling?

The purpose of CE labelling is to avoid technical obstacles to trade within EFTA and the EU. The EU has introduced the CE label as a simple way of showing whether a product complies with the relevant EU directives. The CE label says nothing about the specifications or quality of the product. frequency converters are regulated by three EU directives:

The machinery directive (98/37/EEC)

All machines with critical moving parts are covered by the machinery directive, which came into force on 1 January 1995. Since a frequency converter is largely electrical, it does not fall under the machinery directive. However, if a frequency converter is supplied for use in a machine, we provide information on safety aspects relating to the frequency converter. We do this by means of a manufacturer's declaration.

The low-voltage directive (73/23/EEC)

frequency converters must be CE labelled in accordance with the low-voltage directive, which came into force on 1 January 1997. The directive applies to all electrical equipment and appliances used in the 50 - 1000 Volt AC and the 75 - 1500 Volt DC voltage ranges. Danfoss CE labels in accordance with the directive and issues a declaration of conformity upon request.

The EMC directive (89/336/EEC)

EMC is short for electromagnetic compatibility. The presence of electromagnetic compatibility means that the mutual interference between different components/appliances is so small that the functioning of the appliances is not affected.

The EMC directive came into force on 1 January 1996. Danfoss CE labels in accordance with the directive and issues a declaration of conformity upon request. In order that EMC-correct installation can be carried out, this manual gives detailed instructions for installation. In addition, we specify the standards which our different products comply with. We offer the filters that can be seen from the specifications and provide other types of assistance to ensure the optimum EMC result.

In the great majority of cases, the frequency converter is used by professionals of the trade as a complex component forming part of a larger appliance, system or installation. It must be noted that the responsibility for the final EMC properties of the appliance, system or installation rests with the installer.

situations, explanations are offered as to whether the situation in question is covered by the EMC directive and must be CE labelled.

1. The frequency converter is sold directly to the end-consumer. The frequency converter is for example sold to a DIY market. The end-consumer is a layman. He installs the frequency converter himself for use with a hobby machine, a kitchen appliance, etc. For such applications, the frequency converter must be CE labelled in accordance with the EMC directive.
2. The frequency converter is sold for installation in a plant. The plant is built up by professionals of the trade. It could be a production plant or a heating/ventilation plant designed and installed by professionals of the trade. Neither the frequency converter nor the finished plant has to be CE labelled under the EMC directive. However, the unit must comply with the basic EMC requirements of the directive. The installer can ensure this by using components, appliances and systems that are CE labelled under the EMC directive.
3. The frequency converter is sold as part of a complete system. The system is being marketed as complete. It could be e.g. an air-conditioning system. The complete system must be CE labelled in accordance with the EMC directive. The manufacturer who supplies the system can ensure CE labelling under the EMC directive either by using CE labelled components or by testing the EMC of the system. If he chooses to use only CE labelled components, he does not have to test the entire system.

■ What is covered

The EU "Guidelines on the Application of Council Directive 89/336/EEC" outline three typical situations of using a frequency converter. For each of these

■ Danfoss frequency converter and CE labeling

CE labelling is a positive feature when used for its original purpose, i.e. to facilitate trade within the EU and EFTA.

However, CE labelling may cover many different specifications. This means that it has to be checked what a given CE label specifically covers.

The specifications covered can in fact be widely different. That is why a CE label can give the installer a false feeling of security when using a frequency converter as a component in a system or an appliance.

We CE label our frequency converter in accordance with the low-voltage directive. This means that as long as the frequency converter is installed correctly, we guarantee that it complies with the low-voltage directive. We issue a declaration of conformity that confirms our CE labelling in accordance with the low-voltage directive.

The CE label also applies to the EMC directive, on condition that the instructions given in this manual for EMC-correct installation and filtering have been followed. On this basis, a declaration of conformity in accordance with the EMC directive is issued.

The manual gives detailed instructions for installation to ensure that your installation is EMC-correct. Furthermore, we specify which norms that are complied with by our different products.

We offer the filters that can be seen from the specifications and gladly provide other types of assistance that can help you obtain the best EMC result.

■ Compliance with EMC directive 89/336/EEC

In the great majority of cases, the frequency converter is used by professionals of the trade as a complex component forming part of a larger appliance, system or installation. It must be noted that the responsibility for the final EMC properties of the appliance, system or installation rests with the installer. As an aid to the installer, Danfoss has prepared EMC installation guidelines for the Power Drive System. The standards and test levels stated for Power Drive Systems are complied with, provided the right EMC-correct instructions for installation have been followed, see electrical installation.

EMC test results (Emission, Immunity)

The following test results have been obtained using a system with a frequency converter (with options if relevant), a screened control cable, a control box with potentiometer, as well as a motor and motor cable.

VLT 8006- 8011/ 380- 480V	Emission					
	Environment	Industrial environment		Housing, trades and light industries		
	Basic standard	EN 55011 Class A1		EN 55011 Class B		EN 61800- 3
Setup	Motor cable	Conducted 150 kHz- 30 MHz	Radiated 30 MHz- 1 GHz	Conducted 150 kHz- 30 MHz	Radiated 30 MHz- 1 GHz	Conducted/ radiated 150 kHz- 30 MHz
VLT 8000 with RFI filter option	300 m unscreened/ unarmoured	Yes ²⁾	No	No	No	Yes/ No
	50 m br. screened/ armoured	Yes	Yes	Yes ⁴⁾	No	Yes/ Yes
	150m br. screened/ armoured	Yes	Yes	No	No	Yes/ Yes
VLT 8000 with RFI- filter option (+ LC filter)	300 m unscreened/ unarmoured	Yes	No	No	No	Yes/ No
	50 m br. screened/ armoured	Yes	Yes	Yes ⁴⁾	No	Yes/ Yes
	150m br. screened/ armoured	Yes	Yes	No	No	Yes/ Yes

VLT 8016- 8600/ 380- 480 V VLT 8006- 8062/ 200- 240 V VLT 8052-8402/ 525-690 V	Emission				
	Environment	Industrial environment		Housing, trades and light industries	
	Basic standard	EN 55011 Class A1		EN 55011 Class B	
Setup	Motor cable	Conducted 150 kHz- 30 MHz	Radiated 30 MHz- 1 GHz	Conducted 150 kHz- 30 MHz	Radiated 30 MHz- 1 GHz
VLT 8000 w/ o RFI filter option ^{5) 6)}	300 unscreened/ unarmoured	No	No	No	No
	150 m br. screened/ armoured	No	Yes ⁷⁾	No	No
VLT 8000 with RFI filter option	300 m unscreened / unarmoured	Yes ^{1) 2) 7)}	No	No	No
	50 m br. screened/ armoured	Yes	Yes ⁷⁾	Yes ^{1) 3) 7)}	No
	150 m br. screened/ armoured	Yes	Yes ⁷⁾	No	No

1) Does not apply to VLT 8450-8600

2) Depending on installation conditions

3) VLT 8042- 8062, 200- 240 V with external filter

4) Does not apply to VLT 8011 (380-480 V)

5) VLT 8152-8352, 380-480 V, fulfils class A2 of 50 m unscreened cable without RFI filter (Typecode R0)

6) VLT 8052-8402, 525-690 V fulfils Class A2 at 150 m screened cable without RFI filter (R0)

7) Does not apply to VLT 8052-8402, 525-690 V

In order to minimise the conducted noise to the mains supply and the radiated noise from the frequency converter system, the motor cables should be as short as possible and the screen ends should be made in accordance with the section on electrical installation.



VLT® 8000 AQUA

■ EMC Immunity

In order to confirm immunity against interference from electrical phenomena, the following immunity test has been made on a system consisting of a frequency converter (with options, if relevant), a screened/armoured control cable and control box with potentiometer, motor cable and motor.

The tests were made in accordance with the following basic standards:

EN 61000-4-2 (IEC 1000-4-2): Electrostatic discharges (ESD)

Simulation of electrostatic discharges from human beings.

EN 61000-4-3 (IEC 1000-4-3): Incoming electromagnetic field radiation, amplitude modulated

Simulation of the effects of radar and radio communication equipment as well as mobile communications equipment.

EN 61000-4-4 (IEC 1000-4-4): Burst transients

Simulation of interference brought about by switching with a contactor, relays or similar devices.

EN 61000-4-5 (IEC 1000-4-5): Surge transients

Simulation of transients brought about e.g. by lightning that strikes near installations.

ENV 50204: Incoming electromagnetic field, pulse modulated

Simulation of the impact from GSM telephones.

ENV 61000-4-6: Cable-borne HF

Simulation of the effect of radio transmission equipment connected to supply cables.

VDE 0160 class W2 test pulse: Mains transients

Simulation of high-energy transients brought about by main fuse breakage, switching of power factor-correction capacitors, etc.

■ Immunity, continued

VLT 8006-8600 380-480 V, VLT 8006-8027 200-240 V

Basic standard	Burst IEC 1000-4-4	Surge IEC 1000-4-5		ESD 1000-4-2	Radiated			Radiated radio freq.elect.field ENV 50140	
					electro- magnetic field IEC 1000-4-3	Mains distortion VDE 0160	RF common mode voltage ENV 50141		
									Acceptance criterion
Acceptance criterion	B	B	B	B	A	A	A	A	
Port connection	CM	DM	CM	-	-	CM	CM	-	
Line	OK	OK	-	-	-	OK	OK	-	
Motor	OK	-	-	-	-	-	OK	-	
Control lines	OK	-	OK	-	-	-	OK	-	
PROFIBUS option	OK	-	OK	-	-	-	OK	-	
Signal Interface<3 m	OK	-	-	-	-	-	-	-	
Enclosure	-	-	-	OK	OK	-	-	OK	
Load sharing	OK	-	-	-	-	-	OK	-	
Standard bus	OK	-	OK	-	-	-	OK	-	
Basic specifications				-	-	-	-	-	
Line	4 kV/5kHz/DCN	2 kV/2Ω	4 kV/12Ω	-	-	2,3 x U _N ²⁾	10 V _{RMS}	-	
Motor	4 kV/5kHz/CCC	-	-	-	-	-	10 V _{RMS}	-	
Control lines	2 kV/5kHz/CCC	-	2 kV/2Ω ¹⁾	-	-	-	10 V _{RMS}	-	
PROFIBUS option	2 kV/5kHz/CCC	-	2 kV/2Ω ¹⁾	-	-	-	10 V _{RMS}	-	
Signal interface<3 m	1 kV/5kHz/CCC	-	-	-	-	-	10 V _{RMS}	-	
Enclosure	-	-	-	8 kV AD 6 kV CD	10 V/m	-	-	-	
Load sharing	4 kV/5kHz/CCC	-	-	-	-	-	10 V _{RMS}	-	
Standard bus	2 kV/5kHz/CCC	-	4 kV/2 ¹⁾	-	-	-	10 V _{RMS}	-	

DM: Differential mode

CM: Common mode

CCC: Capacitive clamp coupling

DCN: Direct coupling network

1) Injection on cable shield

 2) 2.3 x U_N: max. test pulse 380 V_{AC}: Class 2/1250 V_{PEAK}, 415 V_{AC}: Class 1/1350 V_{PEAK}

■ Factory settings

PNU #	Parameter description	Factory setting	Range	Changes during operation	4-setup	Con-version index	Data type
001	Language	English		Yes	No	0	5
002	Active Setup	Setup 1		Yes	No	0	5
003	Copying of Setup	No copying		No	No	0	5
004	LCP copy	No copying		No	No	0	5
005	Max value of user-defined readout	100.00	0 - 999.999,99	Yes	Yes	-2	4
006	Unit for user-defined readout	No unit		Yes	Yes	0	5
007	Big display readout	Frequency, % of max.		Yes	Yes	0	5
008	Small display readout 1.1	Reference , Unit		Yes	Yes	0	5
009	Small display readout 1.2	Motor current, A		Yes	Yes	0	5
010	Small display readout 1.3	Power, HP		Yes	Yes	0	5
011	Unit of local reference	Hz		Yes	Yes	0	5
012	Hand start on LCP	Enable		Yes	Yes	0	5
013	OFF/STOP on LCP	Enable		Yes	Yes	0	5
014	Auto start on LCP	Enable		Yes	Yes	0	5
015	Reset on LCP	Enable		Yes	Yes	0	5
016	Lock for data change	Not locked		Yes	Yes	0	5
017	Operating state at power-up, local control	Auto restart		Yes	Yes	0	5
100	Configuration	Open loop		No	Yes	0	5
101	Torque characteristics	Automatic Energy Optimisation		No	Yes	0	5
102	Motor power P_{M,N}	Depends on the unit	1.1-400 kW (1.5-600 HP)	No	Yes	1	6
103	Motor voltage, U_{M,N}	Depends on the unit	208/480/575 V	No	Yes	0	6
104	Motor frequency, f_{M,N}	60 Hz▼ 50 Hz	24-120 Hz	No	Yes	0	6
105	Motor current, I_{M,N}	Depends on the unit	0.01 - I _{MLT,MAX}	No	Yes	-2	7
106	Rated motor speed, n_{M,N}	Depends on par. 102 Motor power	100-60000 rpm	No	Yes	0	6
107	Automatic motor adaptation,AMA	Optimisation disable		No	No	0	5
108	VT start voltage	Depends on par. 103	0.0 - par. 103	Yes	Yes	-1	6
109	Resonance dampening	100 %	0 - 500 %	Yes	Yes	0	6
110	High brake-away torque	0.0 sec.	0.0 - 0.5 sec.	Yes	Yes	-1	5
111	Start delay	0.0 sec.	0.0 - 120.0 sec.	Yes	Yes	-1	6
112	Motor preheater	Disable		Yes	Yes	0	5
113	Motor preheater DC current	50 %	0 - 100 %	Yes	Yes	0	6
114	DC braking current	50 %	0 - 100 %	Yes	Yes	0	6
115	DC braking time	10 sec.	0.0 - 60.0 sec.	Yes	Yes	-1	6
116	DC brake cut-in frequency	OFF	0.0-par. 202	Yes	Yes	-1	6
118	Motor power factor	0.75	0.50-0.99	No	Yes	0	6
117	Motor thermal protection	ETR trip 1		Yes	Yes	0	5
119	Load compensation at low speed	100 %	0 - 300 %	Yes	Yes	0	6
120	Load compensation at high speed	100 %	0 - 300 %	Yes	Yes	0	6
121	Slip compensation	100 %	-500 - 500 %	Yes	Yes	0	3
122	Slip compensation time constant	0.50 sec.	0.05 - 5.00 sec.	Yes	Yes	- 2	6
123	Stator resistance	Depends on the choice of motor		No	Yes	- 4	7
124	Stator reactance	Depends on the choice of motor		No	Yes	- 2	7

▼) Global factory setting different from North American factory setting.

■ Factory settings

PNU #	Parameter description	Factory setting	Range	Changes during operation	4-setup	Conversion index	Data type
201	Output frequency low limit, f_{MIN}	0.0 Hz	0.0 - f_{MAX}	Yes	Yes	-1	6
202	Output frequency, f_{MAX}	60 Hz/▼ 50 Hz	f_{MIN} -120 Hz	Yes	Yes	-1	6
203	Reference site	Hand/Auto linked reference		Yes	Yes	0	5
204	Minimum Reference, Ref_{MIN}	0.000	0.000-par. 100	Yes	Yes	-3	4
205	Maximum Reference, Ref_{MAX}	60 Hz/▼ 50 Hz	par. 100-999.999.999	Yes	Yes	-3	4
206	Ramp-up time	Depends on the unit	1 - 3600	Yes	Yes	0	7
207	Ramp-down time	Depends on the unit	1 - 3600	Yes	Yes	0	7
208	Automatic ramp-up/down	Enable		Yes	Yes	0	5
209	Jog frequency	10.0 Hz	0.0 - par. 100	Yes	Yes	-1	6
210	Reference type	Preset reference/▼ Sum		Yes	Yes	0	5
211	Preset Reference 1	0.00 %	-100.00 - 100.00 %	Yes	Yes	-2	3
212	Preset Reference 2	0.00 %	-100.00 - 100.00 %	Yes	Yes	-2	3
213	Preset Reference 3	0.00 %	-100.00 - 100.00 %	Yes	Yes	-2	3
214	Preset Reference 4	0.00 %	-100.00 - 100.00 %	Yes	Yes	-2	3
215	Current limit, I_{LM}	1.0 x $I_{LT}[A]$	0,1-1,1 x $I_{LT}[A]$	Yes	Yes	-1	6
216	Frequency bypass, bandwidth	0 Hz	0 - 100 Hz	Yes	Yes	0	6
217	Frequency bypass 1	120 Hz	f_{MIN} -120 Hz	Yes	Yes	-1	6
218	Frequency bypass 2	120 Hz	f_{MIN} -120 Hz	Yes	Yes	-1	6
219	Frequency bypass 3	120 Hz	f_{MIN} -120 Hz	Yes	Yes	-1	6
220	Frequency bypass 4	120 Hz	f_{MIN} -120 Hz	Yes	Yes	-1	6
221	Warning: Low current, I_{LOW}	0.0 A	0.0 - par. 222	Yes	Yes	-1	6
222	Warning: High current, I_{HIGH}	$I_{LT,MAX}$	Par. 221 - $I_{LT,MAX}$	Yes	Yes	-1	6
223	Warning: Low frequency f_{LOW}	0.0 Hz	0.0 - par. 224	Yes	Yes	-1	6
224	Warning: High frequency f_{HIGH}	120.0 Hz	Par. 223 - par. 202 (f_{MAX})	Yes	Yes	-1	6
225	Warning: Low reference Ref_{LOW}	-999,999.999	-999,999.999 - par. 226	Yes	Yes	-3	4
226	Warning: Low reference High $High_{HIGH}$	999,999.999	Par. 225 - 999,999.999	Yes	Yes	-3	4
227	Warning: Low feedback FB_{LOW}	-999,999.999	-999,999.999 - par. 228	Yes	Yes	-3	4
228	Warning: High feedback FB_{HIGH}	999,999.999	Par. 227 - 999,999.999	Yes	Yes	-3	4
229	Initial ramp	OFF	000.1-360.0 s	No	Yes	-1	6
230	Fill rate	OFF	000000.001-999999.999	Yes	Yes	-3	7
231	Filled setpoint	Par. 413	Par. 413 to par. 205	Yes	Yes	-3	4

▼) Global factory setting different from North American factory setting.

Changes during operation:

"Yes" means that the parameter can be changed, while the frequency converter is in operation. "No" means that the frequency converter must be stopped before a change can be made.

4-Setup:

"Yes" means that the parameter can be programmed individually in each of the four setups, i.e. the same parameter can have four different data values. "No" means that the data value will be the same in all four setups.

Conversion index:

This number refers to a conversion figure to be used when writing or reading to or from a frequency converter by means of serial communication.

Conversion index	Conversion factor
74	0.1
2	100
1	10
0	1
-1	0.1
-2	0.01
-3	0.001
-4	0.0001

Data type

Data type shows the type and length of the telegram.

Data type	Description
3	Integer 16
4	Integer 32
5	Unsigned 8
6	Unsigned 16
7	Unsigned 32
9	Text string

■ Factory settings

PNU #	Parameter description	Factory setting	Range	Changes during operation	4-setup	Conversion index	Data type
300	Terminal 16 Digital input	Reset		Yes	Yes	0	5
301	Terminal 17 Digital input	No operation		Yes	Yes	0	5
302	Terminal 18 Digital input	Start		Yes	Yes	0	5
303	Terminal 19 Digital input	Reversing		Yes	Yes	0	5
304	Terminal 27 Digital input	Safety interlock/ ▼ Coasting stop, inverse		Yes	Yes	0	5
305	Terminal 29 Digital input	Jog		Yes	Yes	0	5
306	Terminal 32 Digital input	No operation		Yes	Yes	0	5
307	Terminal 33 Digital input	No operation		Yes	Yes	0	5
308	Terminal 53, analog input voltage	No operation		Yes	Yes	0	5
309	Terminal 53, min. scaling	0.0 V	0.0 - 10.0 V	Yes	Yes	-1	5
310	Terminal 53, max. scaling	10.0 V	0.0 - 10.0 V	Yes	Yes	-1	5
311	Terminal 54, analog input voltage	No operation		Yes	Yes	0	5
312	Terminal 54, min. scaling	0.0 V	0.0 - 10.0 V	Yes	Yes	-1	5
313	Terminal 54, max. scaling	10.0 V	0.0 - 10.0 V	Yes	Yes	-1	5
314	Terminal 60, analog input voltage	Reference		Yes	Yes	0	5
315	Terminal 60, min. scaling	4.0 mA	0.0 - 20.0 mA	Yes	Yes	-4	5
316	Terminal 60, max. scaling	20.0 mA	0.0 - 20.0 mA	Yes	Yes	-4	5
317	Time out	10 sec.	1 - 99 sec.	Yes	Yes	0	5
318	Function after time out	Off		Yes	Yes	0	5
319	Terminal 42, output	0 - I _{MAX} ⇒4-20 mA		Yes	Yes	0	5
320	Terminal 42, output pulse scaling			Yes	Yes	0	6
321	Terminal 42, output	0 - f _{MAX} ⇒0-20 mA		Yes	Yes	0	5
322	Terminal 45, output, pulse scaling			Yes	Yes	0	6
323	Relay 1, output function	No alarm		Yes	Yes	0	5
324	Relay 01, ON delay	0.00 sec.	0 - 600 sec.	Yes	Yes	0	6
325	Relay 01, OFF delay	2.00 sec.	0 - 600 sec.	Yes	Yes	0	6
326	Relay 2, output function	Running		Yes	Yes	0	5
327	Pulse reference, max frequency	5000 Hz	Depends on input terminal	Yes	Yes	0	6
328	Pulse feedback, max. frequency	25000 Hz	0 - 65000 Hz	Yes	Yes	0	6
364	Terminal 42, bus control	0	0.0 - 100 %	Yes	Yes	-1	6
365	Terminal 45, bus control	0	0.0 - 100 %	Yes	Yes	-1	6

▼ Coasting stop, inverse is global factory setting different from North American factory setting.

Changes during operation:

"Yes" means that the parameter can be changed, while the frequency converter is in operation. "No" means that the frequency converter must be stopped before a change can be made.

4-Setup:

"Yes" means that the parameter can be programmed individually in each of the four setups, i.e. the same parameter can have four different data values. "No" means that the data value will be the same in all four setups.

Conversion index:

This number refers to a conversion figure to be used when writing or reading to or from a frequency converter by means of serial communication.

Conversion index	Conversion factor
74	0.1
2	100
1	10
0	1
-1	0.1
-2	0.01
-3	0.001
-4	0.0001

Data type:

Data type shows the type and length of the telegram.

Data type	Description
3	Integer 16
4	Integer 32
5	Unsigned 8
6	Unsigned 16
7	Unsigned 32
9	Text string

■ Factory settings

PNU #	Parameter description	Factory setting	Range	Changes during operation	4-setup	Conversion index	Data type
400	Reset function	Infinite Automatic		Yes	Yes	0	5
401	Automatic restart time	10 sec.	0 - 600 sec.	Yes	Yes	0	6
402	Flying start	Enable		Yes	Yes	-1	5
403	Sleep mode timer	Off	0 - 300 sec.	Yes	Yes	0	6
404	Sleep frequency	0 Hz	f_{MIN} - Par. 405	Yes	Yes	-1	6
405	Wake up frequency	60 Hz/▼ 50 Hz	Par. 404 - f_{MAX}	Yes	Yes	-1	6
406	Boost setpoint	100%	1 - 200 %	Yes	Yes	0	6
407	Switching frequency	Depends on the unit	3.0 - 14.0 kHz	Yes	Yes	2	5
408	Interference reduction method	ASFM		Yes	Yes	0	5
409	Function in case of no load	Warning		Yes	Yes	0	5
410	Function at mains failure	Trip		Yes	Yes	0	5
411	Function at overtemperature	Trip		Yes	Yes	0	5
412	Trip delay overcurrent, I_{LM}	60 sec	0 - 60 sec.	Yes	Yes	0	5
413	Minimum feedback, FB_{MIN}	0.000	-999,999.999 - FB_{MIN}	Yes	Yes	-3	4
414	Maximum feedback, FB_{MAX}	100.000	FB_{MIN} - 999,999.999	Yes	Yes	-3	4
415	Units relating to closed loop	%		Yes	Yes	-1	5
416	Feedback conversion	Linear		Yes	Yes	0	5
417	Feedback calculation	Maximum		Yes	Yes	0	5
418	Setpoint 1	0.000	FB_{MIN} - FB_{MAX}	Yes	Yes	-3	4
419	Setpoint 2	0.000	FB_{MIN} - FB_{MAX}	Yes	Yes	-3	4
420	PID normal/inverse control	Normal		Yes	Yes	0	5
421	PID anti windup	On		Yes	Yes	0	5
422	PID start-up frequency	0 Hz	f_{MIN} - f_{MAX}	Yes	Yes	-1	6
423	PID proportional gain	0.01	0.00 - 10.00	Yes	Yes	-2	6
424	PID start-up frequency	Off	0.01 - 9999.00 s. (Off)	Yes	Yes	-2	7
425	PID differentiation time	Off	0.0 (Off) - 10.00 sec.	Yes	Yes	-2	6
426	PID differentiator gain limit	5.0	5.0 - 50.0	Yes	Yes	-1	6
427	PID lowpass filter time	0.01	0.01 - 10.00	Yes	Yes	-2	6
433	Motor alternation time	0 (OFF)	0 - 999 hrs	Yes	Yes	0	6
434	Motor alteration function	Ramp	Ramp/Coast	Yes	Yes	0	6
483	Dynamic DC link compensation	On		No	No	0	5

▼) Global factory setting different from North American factory setting

■ Factory settings

PNU #	Parameter description	Factory setting	Range	Changes during operation	4-setup	Con-ver-sion index	Data type
500	Protocol	FC		Yes	Yes	0	5
501	Address	001	Depends on par.500	Yes	No	0	5
502	Baudrate	9600 BAUD		Yes	No	0	5
503	Coasting	LOGIC OR		Yes	Yes	0	5
504	DC-brake	LOGIC OR		Yes	Yes	0	5
506	Start	LOGIC OR		Yes	Yes	0	5
506	Reversing	DIGITAL INPUT		Yes	Yes	0	5
507	Selection of Setup	LOGIC OR		Yes	Yes	0	5
508	Selection of Preset Reference	LOGIC OR		Yes	Yes	0	5
509	Data Read-out: Reference %			No	No	-1	3
510	Data Read-out: Reference Unit			No	No	-3	4
511	Data Read-out: Feedback			No	No	-3	4
512	Data Read-out: Frequency			No	No	-1	6
513	User Defined Read-out			No	No	-2	7
514	Data Read-out: Current			No	No	-2	7
515	Data Read-out: Power, kW			No	No	1	7
516	Data Read-out: Power, HP			No	No	-2	7
517	Data Read-out: Motor Voltage			No	No	-1	6
518	Data Read-out: DC Link Voltage			No	No	0	6
519	Data Read-out: Motor temp.			No	No	0	5
520	Data Read-out: VLT Temp.			No	No	0	5
521	Data Read-out: Digital Input			No	No	0	5
522	Data Read-out: Terminal 53, Analog Input			No	No	-1	3
523	Data Read-out: Terminal 54, Analog Input			No	No	-1	3
524	Data Read-out: Terminal 60 Analog Input			No	No	-4	3
525	Data Read-out: Pulse reference			No	No	-1	7
526	Data Read-out: External Reference %			No	No	-1	3
527	Data Read-out: Status Word, Hex			No	No	0	6
528	Data Read-out: Heat Sink Temperatur			No	No	0	5
529	Data Read-out: Alarm Word, Hex			No	No	0	7
530	Data Read-out: Control Word, Hex			No	No	0	6
531	Data Read-out: Warning Word, Hex			No	No	0	7
532	Data Read-out: Extended Status Word, Hex			No	No	0	7
533	Display Text 1			No	No	0	9
534	Display Text 2			No	No	0	9
535	Bus Feedback 1	00000		No	No	0	3
536	Bus Feedback 2	00000		No	No	0	3
537	Data Read-out: Relay Status			No	No	0	5
555	Bus Time Interval	60 sec.	1 to 99 sec.	Yes	Yes	0	5
556	Bus Time Interval Function	NO FUNCTION		Yes	Yes	0	5
570	Modbus parity and message framing	No parity	1 stopbit	Yes	Yes	0	5
571	Modbus communications timeout	100 ms	10-2000 ms	Yes	Yes	-3	6

■ Factory settings

PNU #	Parameter description	Factory setting	Range	Changes during operation	4-setup	Conversion index	Data type
600	Operating data: Operating hours			No	No	74	7
601	Operating data: Hours run			No	No	74	7
602	Operating data: kWh counter			No	No	1	7
603	Operating data: No. of cut-ins			No	No	0	6
604	Operating data: No. of overtemps			No	No	0	6
606	Operating data: No. of overvoltages			No	No	0	6
606	Data log: Digital input			No	No	0	5
607	Data log: Control word			No	No	0	5
608	Data log: Status word			No	No	0	6
609	Data log: Reference			No	No	-1	3
610	Data log: Feedback			No	No	-3	4
611	Data log: Output frequency			No	No	-1	3
612	Data log: Output voltage			No	No	-1	6
613	Data log: r Output current			No	No	-2	3
614	Data log: DC link voltage			No	No	0	6
615	Fault log: Error code			No	No	0	5
616	Fault log: Time			No	No	0	7
617	Fault log: Value			No	No	0	3
618	Reset of kWh counter	No reset		Yes	No	0	5
619	Reset of hours-run counter	No reset		Yes	No	0	5
620	Operating mode	Normal function		Yes	No	0	5
621	Nameplate: Unit type			No	No	0	9
622	Nameplate: Power component			No	No	0	9
623	Nameplate: VLT ordering no.			No	No	0	9
624	Nameplate: Software version no.			No	No	0	9
625	Nameplate: LCP identification no.			No	No	0	9
626	Nameplate: Database identification no.			No	No	-2	9
627	Nameplate: Power component identification no.			No	No	0	9
628	Nameplate: Application option type			No	No	0	9
629	Nameplate: Application option ordering no.			No	No	0	9
630	Nameplate: Communication option type			No	No	0	9
631	Nameplate: Communication option ordering no.			No	No	0	9

Changes during operation:

"Yes" means that the parameter can be changed, while the frequency converter is in operation. "No" means that the frequency converter must be stopped before a change can be made.

4-Setup:

"Yes" means that the parameter can be programmed individually in each of the four setups, i.e. the same parameter can have four different data values. "No" means that the data value will be the same in all four setups.

Conversion index:

This number refers to a conversion figure to be used when writing or reading to or from a frequency converter by means of serial communication.

Conversion index	Conversion factor
74	0.1
2	100
1	10
0	1
-1	0.1
-2	0.01
-3	0.001
-4	0.0001

Data type:

Data type shows the type and length of the telegram.

Data type	Description
3	Integer 16
4	Integer 32
5	Unsigned 8
6	Unsigned 16
7	Unsigned 32
9	Text string

■ Option Card (for the four relay option card)

PNU #	Parameter description	Factory setting	Range	Changes during operation	4-setup	Con- ver- sion index	Data type
700	Relay 6, Output Function	Running		Yes	Yes	0	5
701	Relay 6, On Delay	000 sec.	0 to 600 sec.	Yes	Yes	-2	6
702	Relay 6, Off Delay	000 sec.	0 to 600 sec.	Yes	Yes	-2	6
703	Relay 7, Output Function	NO FUNCTION		Yes	Yes	0	5
704	Relay 7, On Delay	000 sec.	0 to 600 sec.	Yes	Yes	-2	6
705	Relay 7, Off Delay	000 sec.	0 to 600 sec.	Yes	Yes	-2	6
706	Relay 8, Output Function	NO FUNCTION		Yes	Yes	0	5
707	Relay 8, On Delay	000 sec.	0 to 600 sec.	Yes	Yes	-2	6
708	Relay 8, Off Delay	000 sec.	0 to 600 sec.	Yes	Yes	-2	6
709	Relay 9, Output Function	NO FUNCTION		Yes	Yes	0	5
710	Relay 9, On Delay	000 sec.	0 to 600 sec.	Yes	Yes	-2	6
711	Relay 9, Off Delay	000 sec.	0 to 600 sec.	Yes	Yes	-2	6

Index
A

analogue inputs.....	31
analogue outputs:.....	31
AWG.....	5
Address.....	149
AEO - Automatic Energy Optimization	30
AEO:.....	5
Aggressive environments	172
Air humidity	179
Alarm word	158
Alarms.....	167
Analogue inputs	117
Anti windup	137
Application functions	126
Auto start on LCP.....	93

B

baud rate.....	140
Baudrate.....	149
Broadcast	140
Bus connection.....	73
Bus feedback 1	156

C

Cable lengths and cross-sections:	32
Cables	54
CE labelling	182
Change parameter data	86
Changing data	85
Connection example.....	77
Control and reply telegrams	140
Control characteristics	33
Control keys	80
Control principle	30
Cooling.....	52
Copying of Setups.....	89
Correct earthing/grounding	61

D

Data character	141
Data control byte.....	141
Data log	160
Dataread-out	153
DC braking.....	100
Derating for air pressure.....	178
Derating for ambient temperature.....	178
Derating for high switching frequency.....	179
Digital inputs.....	114

Digital inputs:.....	30
Digital speed up/down	78
Direction of IEC motor rotation	110
Display mode.....	81
Display mode I	82
Display readout	160
Displaytext.....	156

E

EMC test results.....	183
Earth fault	175
Earth leakage current.....	174
earth potential	61
Earthing	54
Earthing/Grounding of screened/armoured control cables	61
Efficiency	180
Electrical installation,.....	65
Electrical installation, Control cables.....	74
Electrical installation, enclosures	62
EMC Immunity	185
EMC-correct electrical installation.....	59
Enclosures	106
External 24 Volt DC supply :	32
Externals:	33
Extra protection.....	55
Extreme running conditions.....	175

F

Factory settings.....	187
Faultlog	160
FC protocol.....	140
Feedback	130
Feedback handling.....	134
Flyingstart	126
Frequencybypass.....	109
Function at mains failure	129
Function at overtemperature	129
Fuses.....	46

G

Galvanic isolation (PELV)*	173
General technical data	30
Ground fault (GROUND FAULT).....	169

H

Hand start.....	116
Hand start on LCP.....	93
Hand/Auto linked reference.....	106
Harmonic filter.....	23, 139

Harmonic filters	32
Heat emission	58
High voltage test	58

I

IT mains	56
Indicator lamps	81
Initialisation	85
Inputs and outputs.....	114
Installation of 24 Volt external DC supply	73

L

Low current.....	110
Language.....	88
LCP copy	89
Load and motor	95
Local control	81
Lock for data change	94
Lowpass.....	138

M

Mains drop-out	175
Mains supply	33
MCT 10.....	31
Mechanical installation	52
Motor Alternation Time.....	139
Motor frequency	97
Motor thermal protection.....	100
Motor-generated overvoltage	175
Motorcurrent.....	97
Motorpower.....	95
Motorvoltage	96

O

OFF/STOP on LCP	93
Output data.....	33

P

Profibus DP-V1	32
Parallel coupling of motors.....	72
Parameter Data	86
PC software	13
PC Software tools.....	31
Peak voltage on motor.....	176
Potentiometer reference	130
Power factor.....	181
Preset reference	109
Programming.....	88
Protection	33
Protocols	140

Pulse feedback.....	116
Pulse input	31
Pulse reference	116
Pulse scaling	122

Q

Quick Menu.....	86
-----------------	----

R

Ramp-down time.....	107
Ramp-uptime.....	106
RCD	174
Reference handling	105
Reference type.....	108
References and Limits	104
Relay outputs:.....	32
Relay01	124
Reset on LCP	93
Resetfunction.....	126
Resulting reference	173
RFI switch	56
Rise time.....	176
Rotation.....	72
RS 485 serial communication	32

S

screw sizes	71
Safety regulations	30
Screened/armoured cables	54
Serial communication	140
Service functions	159
Setpoint.....	136
Setup.....	156
Setup configuration	88
Setup of user-defined readout	89
Short circuit.....	175
Single-pole start/stop	78
Sleep mode.....	127
Software version.....	4
Static overload	175
Status messages	165
Switches 1-4	75
Switching frequency	128
Switching on the input	178
Switching on the output	175

T

Trip locked	6
Technical data, mains supply 3 x 200 - 240 V	35, 36
Technical data, mains supply 3 x 380 - 480 V	37, 39, 40

Technical data, mains supply 3 x 525 - 600 V 42, 43
Telegram build-up.....140
Telegram communication140
Telegram length141
Tightening torque..... 71
Time out119
Torque characteristics 95
Transmitter connection..... 78
Type code ordering number string..... 32

U

Use of emc-correct cables107

V

Ventilation 58

W

Warning words.....158
Warning: High reference111
Warnings167
Warnings and alarms.....167
Wrong earthing/grounding 61

2

2-zone regulation..... 78

5

50/60 Hz earth loops..... 61