

Contents

■ How to Read these Operating Instructions	3
□ Approvals	4
□ Symbols	5
□ Abbreviations	5
■ Safety Instructions and General Warning	7
□ Software Version	7
□ High Voltage Warning	8
□ Safety Instructions	8
□ Avoid Unintended Start	8
□ Safe Stop of FC 302	8
□ IT Mains	9
■ How to Install	11
□ How to Get Started	11
□ Accessory Bag ≤ 7.5 kW	12
□ Mechanical Installation	13
□ Electrical Installation	15
□ Removal of Knockouts for Extra Cables	15
□ Connection to Mains and Earthing	15
□ Motor Connection	17
□ Motor Cables	19
□ Fuses	20
□ Access to Control Terminals	22
□ Electrical Installation, Control Terminals	22
□ Basic Wiring Example	23
□ Electrical Installation, Control Cables	24
□ Switches S201, S202, and S801	25
□ Tightening Torque	25
□ Final Set-Up and Test	26
□ Additional Connections	28
□ 24 V Back-up Option	28
□ Mounting of Option Modules in Slot B (MCB 101 and MCB 102)	29
□ General Purpose Input Output Module MCB 101	29
□ Encoder Option MCB 102	31
□ Load Sharing	32
□ Relay Option MCB 105	33
□ Brake Connection Option	36
□ Relay Connection	36
□ Control of Mechanical Brake	37
□ Motor Thermal Protection	37
■ How to Programme	39
□ The Local Control Panel	39
□ How to Programme on the Graphical Local Control Panel	39
□ Quick Transfer of Parameter Settings	42
□ Reset to Default Setting	43
□ Adjust Display Contrast	43
□ Connection Examples	44
□ Start/Stop	44
□ Pulse Start/Stop	44

- Speed Up/Down 44
 - Potentiometer Reference 44
 - Basic Parameters 45
 - Parameter Lists 47
- **General Specifications** 63
- **Troubleshooting** 69
 - Warnings/Alarm Messages 69
- **Index** 77

How to Read these Operating Instructions

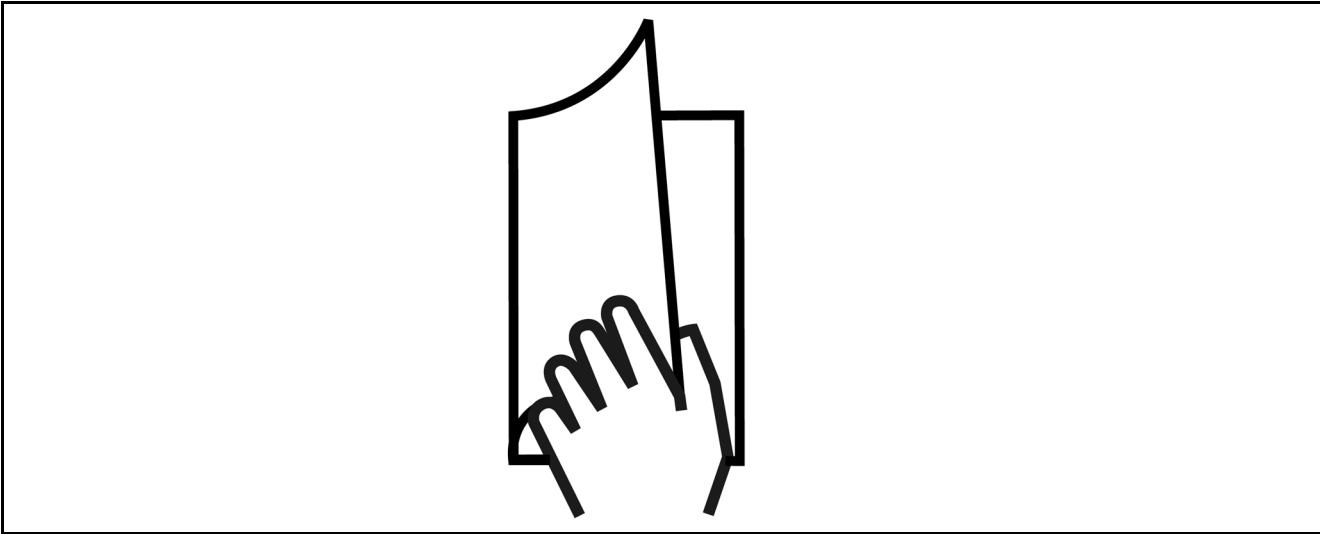

□ **How to Read these Operating Instructions**

These Operating Instructions will help you get started, install, program, and troubleshoot your VLT® AutomationDrive FC 300.

The FC 300 comes in two shaft performance levels. FC 301 ranges from scalar (U/f) to VVC+, and FC 302 ranges from scalar (U/f) to servo performance.

These Operating Instructions cover both FC 301 and FC 302. Where information covers both series, we refer to FC 300. Otherwise, we refer specifically to either FC 301 or FC 302.

Chapter 1, **How to Read these Operating Instructions**, introduces the manual and informs you about the approvals, symbols, and abbreviations used in this literature.

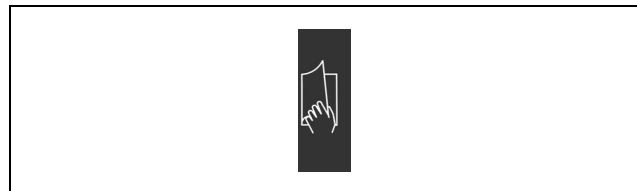

Page divider for How to Read these Operating Instructions.

Chapter 2, **Safety Instructions and General Warnings**, entails instructions on how to handle the FC 300 correctly.

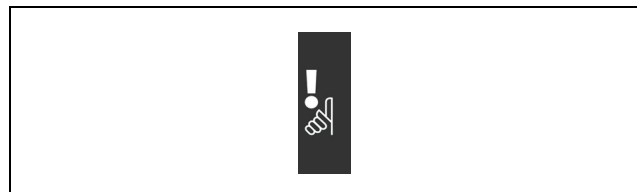

Page divider for Safety Instructions and General Warnings.

Chapter 3, **How to Install**, guides you through mechanical and technical installation.

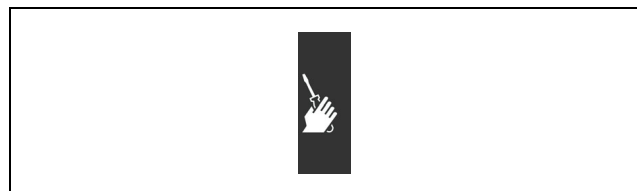

Page divider for How to Install

— How to Read these Operating Instructions —



Chapter 4, **How to Programme**, shows you how to operate and programme the FC 300 via the Local Control Panel.

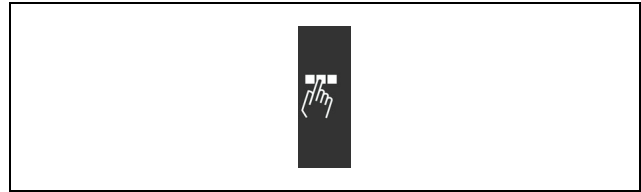

Page divider for How to Programme.

Chapter 5, **General Specifications**, entails technical data about FC 300.



Page divider for General Specifications.

Chapter 6, **Troubleshooting**, assists you in solving problems that may occur when using FC 300.

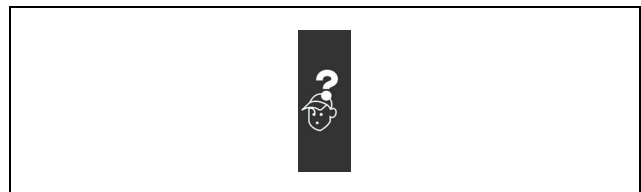

Page divider for Troubleshooting.

Available literature for FC 300

- The VLT® AutomationDrive FC 300 Operating Instructions provide the necessary information for getting the drive up and running.
- The VLT® AutomationDrive FC 300 Design Guide entails all technical information about the drive and customer design and applications.
- The VLT® AutomationDrive FC 300 Profibus Operating Instructions provide the information required for controlling, monitoring and programming the drive via a Profibus fieldbus.
- The VLT® AutomationDrive FC 300 DeviceNet Operating Instructions provide the information required for controlling, monitoring and programming the drive via a DeviceNet fieldbus.
- The VLT® AutomationDrive FC 300 MCT 10 Operating Instructions provide information for installation and use of the software on a PC.
- The VLT® AutomationDrive FC 300 IP21 / TYPE 1 Instruction provides information for installing the IP21 / TYPE 1 option.
- The VLT® AutomationDrive FC 300 24 V DC Backup Instruction provides information for installing the 24 V DC Backup option.

Danfoss Drives technical literature is also available online at www.danfoss.com/drives.

Approvals



— How to Read these Operating Instructions —

□ **Symbols**

Symbols used in these Operating Instructions.



NB!:
Indicates something to be noted by the reader.



Indicates a general warning.



Indicates a high-voltage warning.

* Indicates default setting

□ **Abbreviations**

Alternating current	AC
American wire gauge	AWG
Ampere/AMP	A
Automatic Motor Adaptation	AMA
Current limit	I_{LIM}
Degrees celcius	°C
Direct current	DC
Drive Dependent	D-TYPE
Electronic Thermistor Relay	ETR
Frequency Converter	FC
Gram	g
Hertz	Hz
Kilohertz	kHz
Local Control Panel	LCP
Meter	m
Milliampere	mA
Millisecond	ms
Minute	min
Motion Control Tool	MCT
Motor Type Dependent	M-TYPE
Nanofarad	nF
Newton Meters	Nm
Nominal motor current	$I_{M,N}$
Nominal motor frequency	$f_{M,N}$
Nominal motor power	$P_{M,N}$
Nominal motor voltage	$U_{M,N}$
Parameter	par.
Rated Inverter Output Current	I_{INV}
Revolutions Per Minute	RPM
Second	s
Torque limit	T_{LIM}
Volts	V



— How to Read these Operating Instructions —



Safety Instructions and General Warning

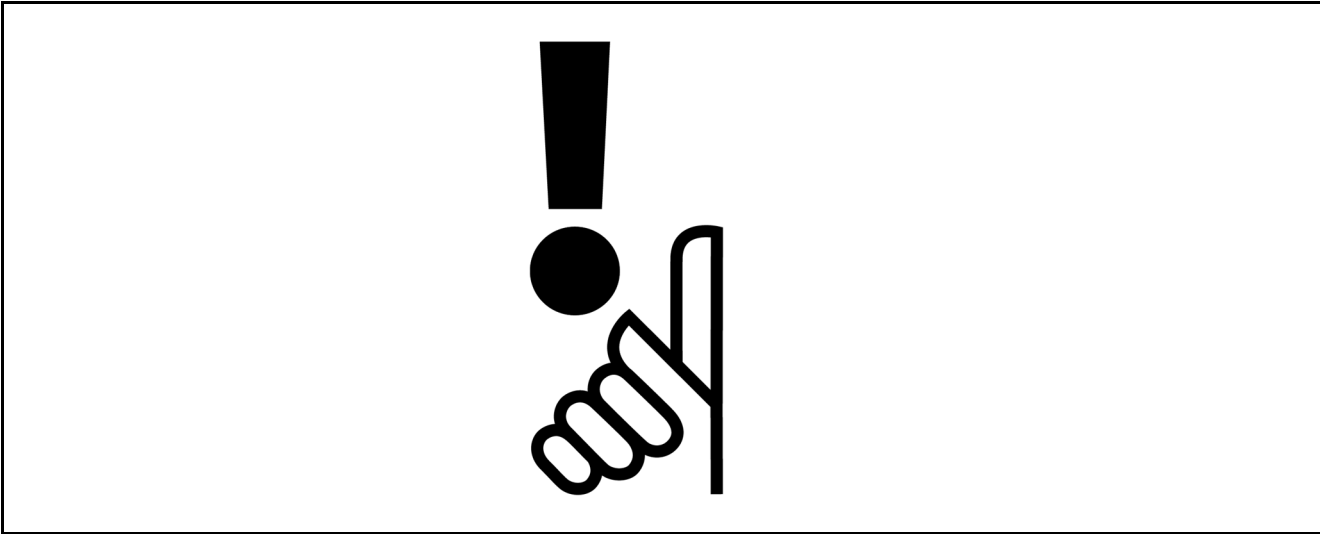

130BA141.12

FC 300

Operating Instructions

Software version: 3.xx

These Operating Instructions can be used for all FC 300 frequency converters with software version 3.xx. The software version number can be seen from parameter 15-43.

— Safety Instructions and General Warning —

□ High Voltage Warning



The voltage of the FC 300 is dangerous whenever the converter is connected to mains. Incorrect fitting of the motor or VLT may cause damage to the equipment, serious injury or death. Consequently, it is essential to comply with the instructions in this manual as well as local and national rules and safety regulations.

□ Safety Instructions

- Make sure the FC 300 is properly connected to earth.
- Do not remove mains plugs or motor plugs while the FC 300 is connected to mains.
- Protect users against supply voltage.
- Protect the motor against overloading according to national and local regulations.
- Motor overload protection is not included in the default settings. To add this function, set parameter 1-90 *Motor thermal protection* to value *ETR trip* or *ETR warning*. For the North American market: ETR functions provide class 20 motor overload protection, in accordance with NEC.
- The earth leakage current exceeds 3.5 mA.
- The [OFF] key is not a safety switch. It does not disconnect the FC 300 from mains.

□ Before Commencing Repair Work

1. Disconnect FC 300 from mains
2. Disconnect DC bus terminals 88 and 89
3. Wait at least 15 minutes
4. Remove motor cable

□ Avoid Unintended Start

While FC 300 is connected to mains, the motor can be started/stopped using digital commands, bus commands, references or via the LCP.

- Disconnect the FC 300 from mains whenever personal safety considerations make it necessary to avoid unintended start.
- To avoid unintended start, always activate the [OFF] key before changing parameters.
- Unless terminal 37 is turned off, an electronic fault, temporary overload, a fault in the mains supply, or lost motor connection may cause a stopped motor to start.

□ Safe Stop of FC 302

The FC 302 can perform the Designated Safety Function *Uncontrolled Stopping* by removal of power. (as defined by draft IEC 61800-5-2) or *Stop Category 0* (as defined in EN 60204-1). It is designed and approved suitable for the requirements of Safety Category 3 in EN 954-1. This functionality is called Safe Stop.

Prior to integration and use of FC 302 Safe Stop in an installation, a thorough risk analysis on the installation must be carried out in order to determine whether the FC 302 Safe Stop functionality and safety category are appropriate and sufficient.

In order to install and use the Safe Stop function in accordance with the requirements of Safety Category 3 in EN 954-1, the related information and instructions of the FC 300 Design Guide MG.33.BX.YY must be followed ! The information and instructions of the Operating Instructions are not sufficient for a correct and safe use of the Safe Stop functionality!

— Safety Instructions and General Warning —

General warning**Warning:**

Touching the electrical parts may be fatal - even after the equipment has been disconnected from mains.

Also make sure that other voltage inputs have been disconnected, such as load-sharing (linkage of DC intermediate circuit), as well as the motor connection for kinetic back-up.

Using VLT AutomationDrive FC 300: wait at least 15 minutes.

Shorter time is allowed only if indicated on the nameplate for the specific unit.

**Leakage Current**

The earth leakage current from the FC 300 exceeds 3.5 mA. To ensure that the earth cable has a good mechanical connection to the earth connection (terminal 95), the cable cross section must be at least 10 mm² or 2 rated earth wires terminated separately.

Residual Current Device

This product can cause a D.C. current in the protective conductor. Where a residual current device (RCD) is used for extra protection, only an RCD of Type B (time delayed) shall be used on the supply side of this product. See also RCD Application Note MN.90.GX.02.

Protective earthing of the FC 300 and the use of RCD's must always follow national and local regulations.

**IT Mains**

Do not connect 400 V frequency converters with RFI-filters to mains supplies with a voltage between phase and earth of more than 440 V.

For IT mains and delta earth (grounded leg), mains voltage may exceed 440 V between phase and earth.

Par. 14-50 *RFI 1* can on FC 302 be used to disconnect the internal RFI capacitors from the RFI filter to ground. If this is done it will reduce the RFI performance to A2 level.



— Safety Instructions and General Warning —



How to Install

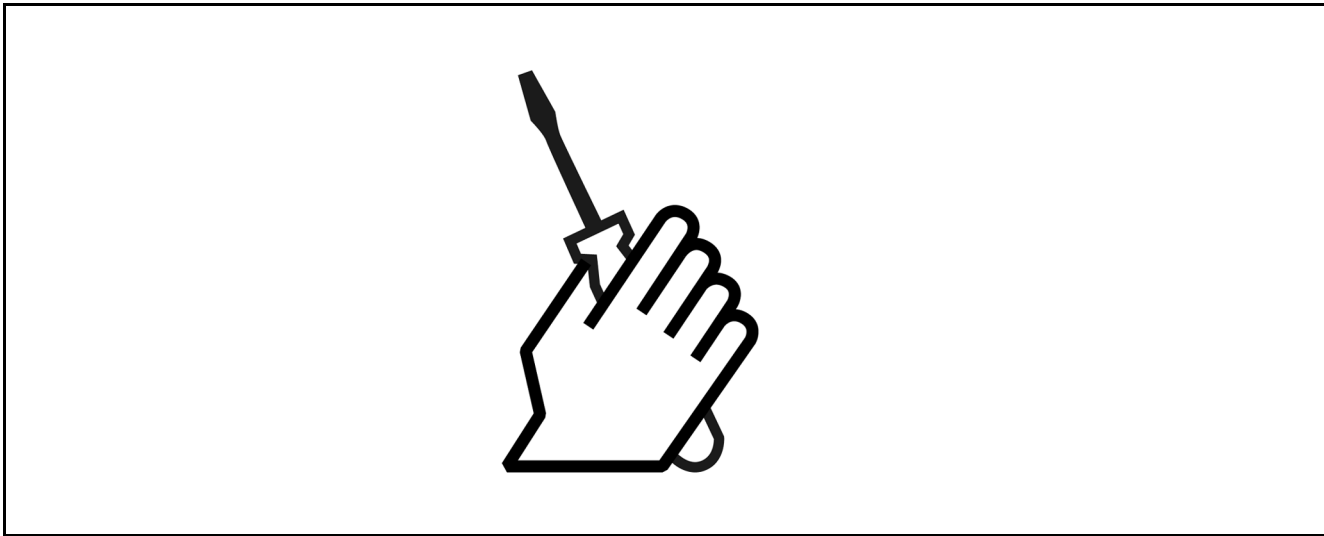

□ **About How to Install**

This chapter covers mechanical and electrical installations to and from power terminals and control card terminals. Electrical installation of *options* is described in the corresponding Instructions.

□ **How to Get Started**

You can carry out a quick and EMC-correct installation of the FC 300 by following the steps described below.



Read the safety instructions before installing the unit.

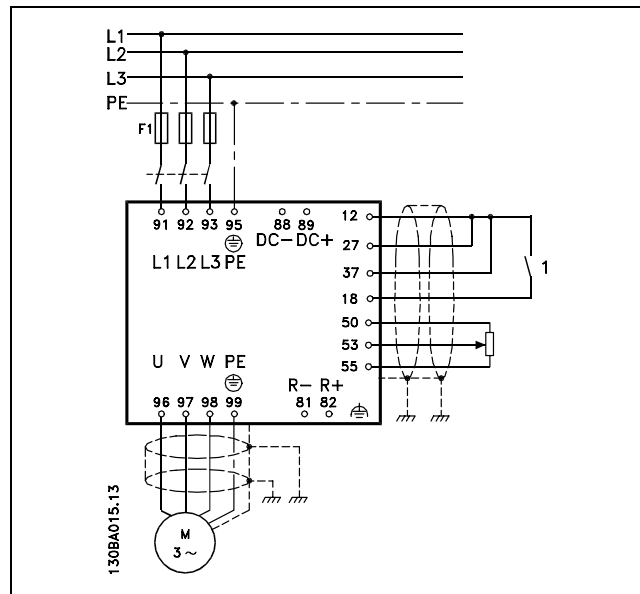

Diagram showing basic installation including mains, motor, start/stop key, and potentiometer for speed adjustment.



— How to Install —

□ **Accessory Bag ≤ 7.5 kW**

Find the following parts included in the FC 300 Accessory Bag.

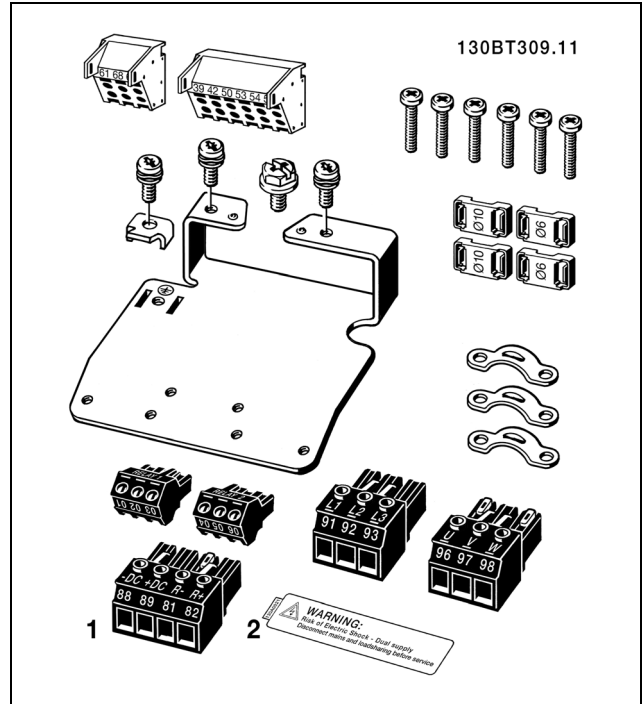

1 + 2 only available in units with brake chopper.
There is only one relay connector for FC 301. (≤ 7.5 kW)

Accessory Bag ≤ 7.5 kW, IP 55

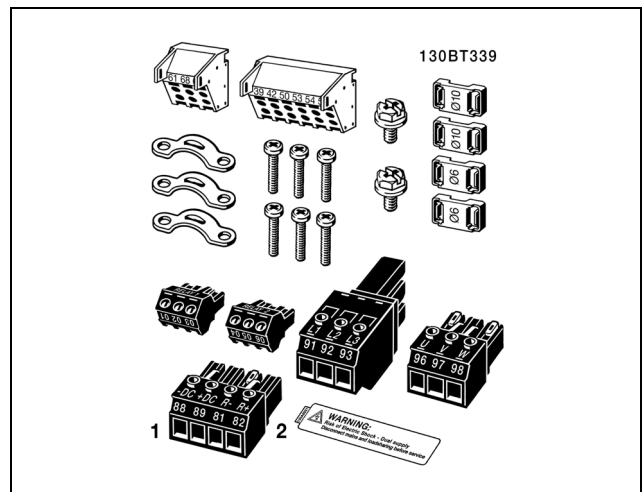

1 + 2 only available in units with brake chopper.
There is only one relay connector for FC 301.
(≤ 7.5 kW, IP55)



— How to Install —

Accessory Bag 11-22 kW

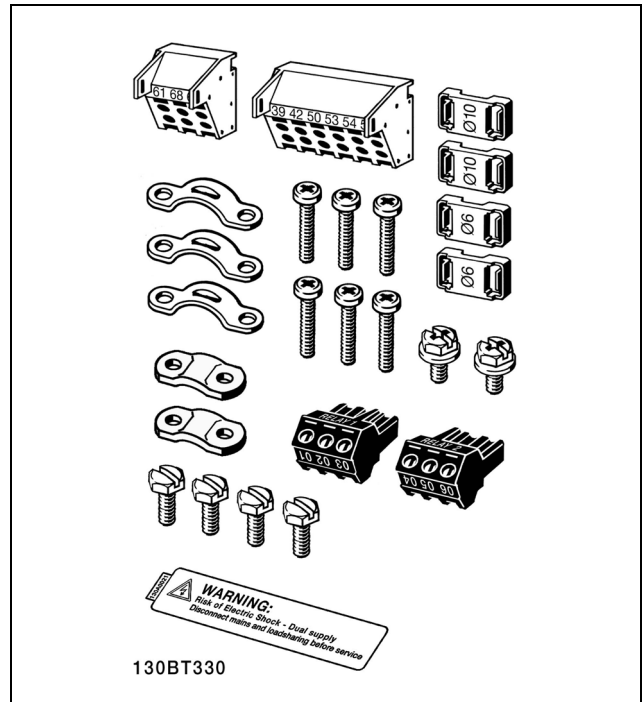

There is only one relay connector for FC 301. (11-22 kW)

□ **Mechanical Installation**

□ **Basic Enclosures**

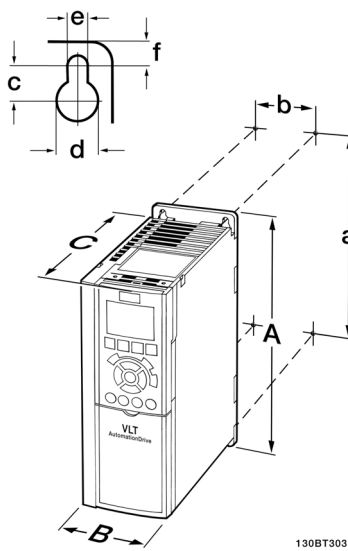

FC 300 IP20 - see table for mechanical dimensions

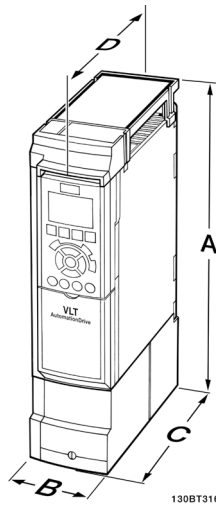

Mechanical dimensions of the IP 21/IP 4x/ TYPE 1 enclosure kit (≤ 7.5 kW)

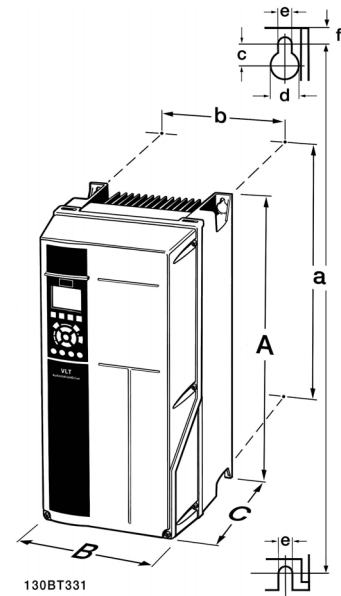

Mechanical dimensions of the IP 21/IP 4x/ TYPE 1/IP55/TYPE 12 (11-22 kW)



— How to Install —

Mechanical dimensions								
		Frame size A2 0.25-2.2 kW (200-240 V) 0.37-4.0 kW (380-500 V)		Frame size A3 3.0-3.7 kW (200-240 V) 5.5-7.5 kW (380-500 V) 0.75-7.5 kW (550-600 V)		Frame size A5 0.25-3.7 kW (200-500 V) 0.37-7.5 kW (380-500 V)	Frame size B1 11-15 kW (380-500 V)	Frame size B2 18.5-22 kW (380-500 V)
		IP20	IP21/Type 1	IP20	IP21/Type 1	IP55	IP21	IP21
Height								
Height of back plate	A	268 mm	375 mm	268 mm	375 mm	420 mm	480 mm	650 mm
Distance between mounting holes	a	257 mm	350 mm	257 mm	350 mm	402 mm	454 mm	624 mm
Width								
Width of back plate	B	90 mm	90 mm		130 mm	242 mm	242 mm	242 mm
Distance between mounting holes	b	70 mm	70 mm	110 mm	110 mm	215 mm	210 mm	210 mm
Depth								
Depth without option A/B	C	205 mm	205 mm	205 mm	205 mm	195 mm	260 mm	260 mm
With option A/B		220 mm		220 mm		195 mm		260 mm
Without option A/B	D		207 mm					
With option A/B	D		222 mm					
Screw holes								
	c	8.0 mm	8.0 mm	8.0 mm	8.0 mm	8.25 mm	12 mm	12 mm
	d	ø11 mm	ø11 mm	ø11 mm	ø11 mm	ø12 mm	ø19 mm	ø19 mm
	e	ø5.5 mm	ø5.5 mm	ø5.5 mm	ø5.5 mm	ø6.5 mm	ø9 mm	ø9 mm
	f	9 mm	9 mm	9 mm	9 mm	9 mm	9 mm	9 mm
Max weight		4.9 kg	5.3 kg	6.6 kg	7.0 kg		23 kg	27 kg



Mechanical mounting

1. Drill holes in accordance with the measurements given.
2. You must provide screws suitable for the surface on which you want to mount the FC 300. Retighten all four screws.

FC 300 IP20 allows side-by-side installation. Because of the need for cooling, there must be a minimum of 100 mm free air passage above and below the FC 300.

The back wall must always be solid.

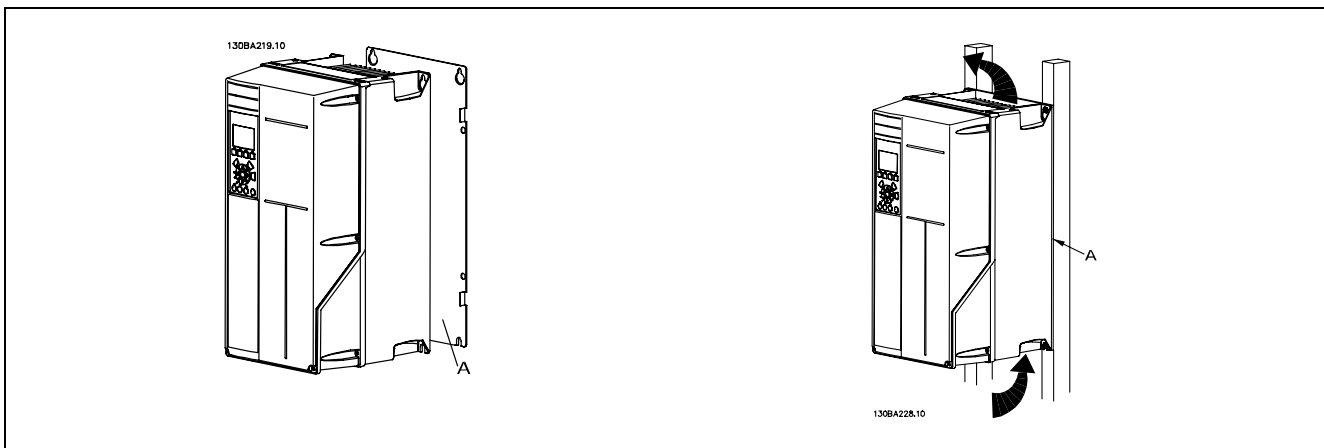

□ Electrical Installation



NB!:
Cables General

Always comply with national and local regulations on cable cross-sections.

Tightening-up Torque		
FC size	Cable for:	Tightening up torque
0.25-7.5 kW	Line, Brake resistor, load sharing Motor cable	0.5-0.6 Nm
		1.8 Nm
11-15 kW	Line, Brake resistor, load sharing Motor cable	1.8 Nm
11-15 kW	Motor cable	1.8 Nm
	Relay	0.5-0.6 Nm
	Earth	2-3 Nm

□ Removal of Knockouts for Extra Cables

1. Remove cable entry from the frequency converter (Avoiding foreign parts in the frequency converter when removing knockouts)
2. Cable entry has to be supported around the knockout you intend to remove.
3. The knockout can now be removed with a strong mandrel and a hammer.
4. Remove burrs from the hole.
5. Mount Cable entry on frequency converter.



□ Connection to Mains and Earthing



NB!:
The plug connector for power can be removed.

1. Make sure the FC 300 is properly earthed. Connect to earth connection (terminal 95). Use screw from the accessory bag.
2. Place plug connector 91, 92, 93 from the accessory bag onto the terminals labelled MAINS at the bottom of FC 300.
3. Connect mains wires to the mains plug connector.



The earth connection cable cross section must be at least 10 mm² or 2 rated mains wires terminated separately according to EN 50178.

The mains connection is fitted to the main switch if this is included.

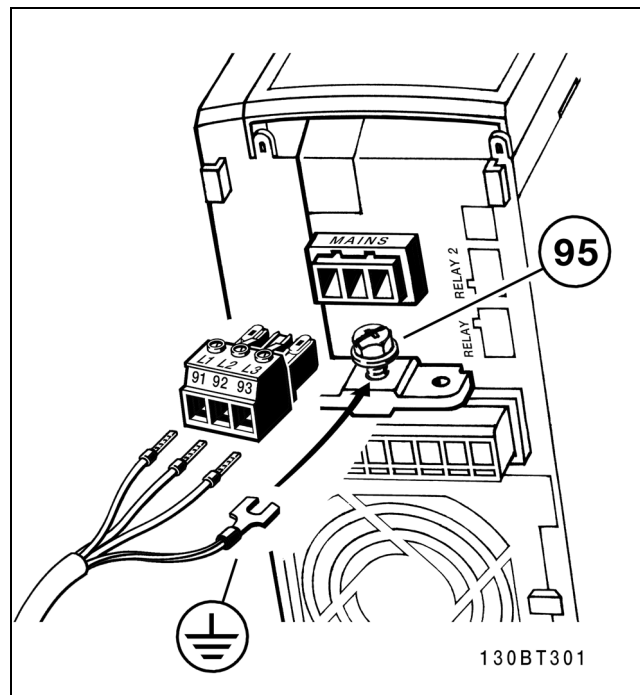

How to connect to mains and earthing (A2 and A3 enclosure).

— How to Install —

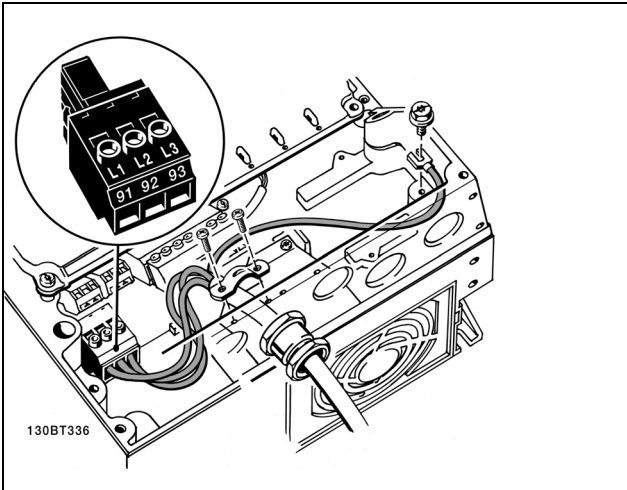

How to connect to mains and earthing (A5 enclosure).

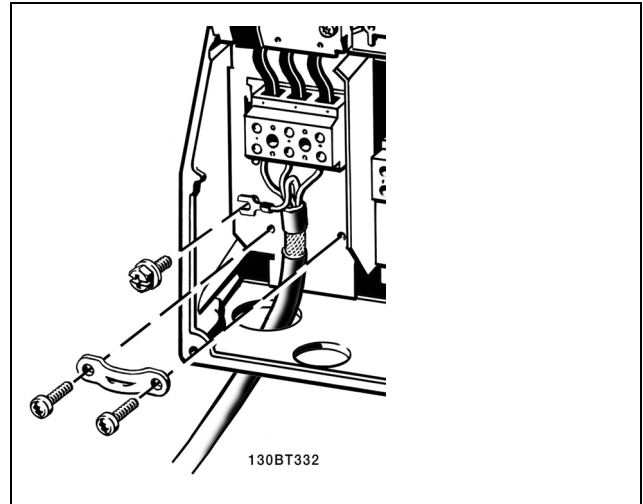

How to connect to mains and earthing (B1 and B2 enclosure).



NB!:

Check that mains voltage corresponds to the mains voltage of the FC 300 name plate.



IT Mains

Do not connect 400 V frequency converters with RFI-filters to mains supplies with a voltage between phase and earth of more than 440 V.

For IT mains and delta earth (grounded leg), mains voltage may exceed 440 V between phase and earth.

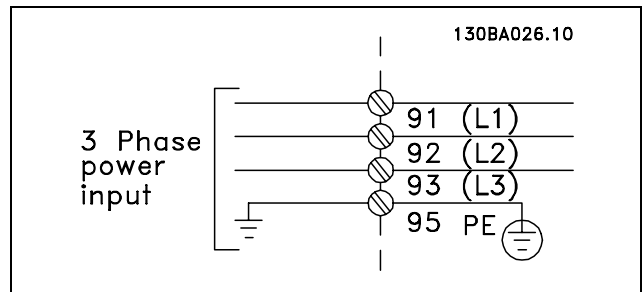

Terminals for mains and earthing.

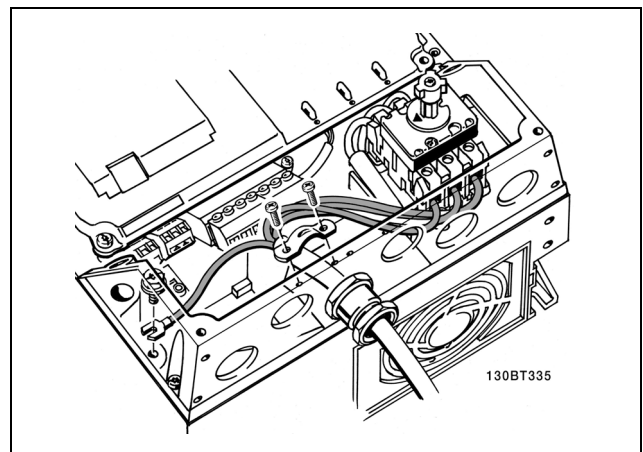

How to connect to mains and earthing with disconnector (A5 enclosure).

— How to Install —

□ **Motor Connection****NB!:**

Motor cable must be screened/armoured.

If an unscreened/unarmoured cable is used, some EMC requirements are

not complied with. For more information, see *EMC specifications* in the *VLT AutomationDrive FC 300 Design Guide*.

1. Fasten decoupling plate to the bottom of FC 300 with screws and washers from the accessory bag.

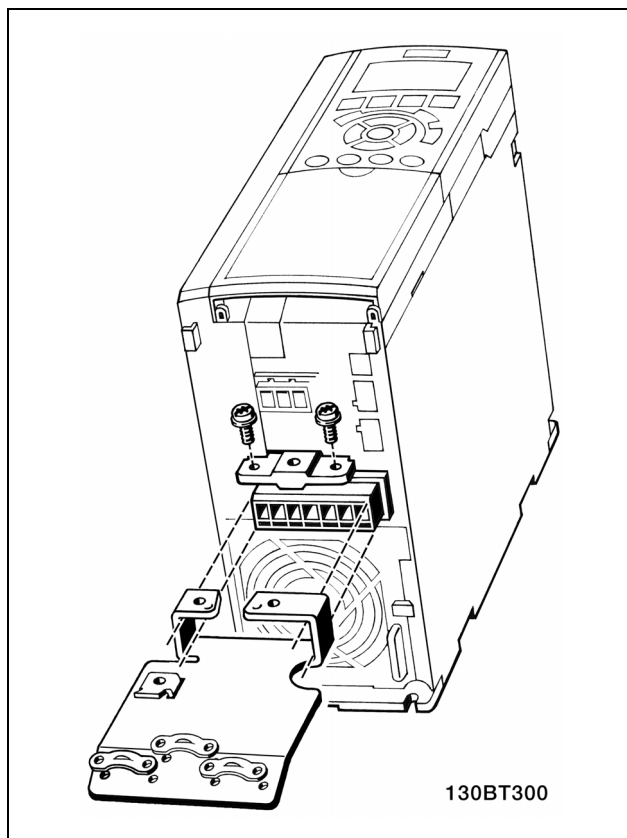

2. Attach motor cable to terminals 96 (U), 97 (V), 98 (W).
3. Connect to earth connection (terminal 99) on decoupling plate with screws from the accessory bag.
4. Insert plug connectors 96 (U), 97 (V), 98 (W) and motor cable to terminals labelled MOTOR.
5. Fasten screened cable to decoupling plate with screws and washers from the accessory bag.

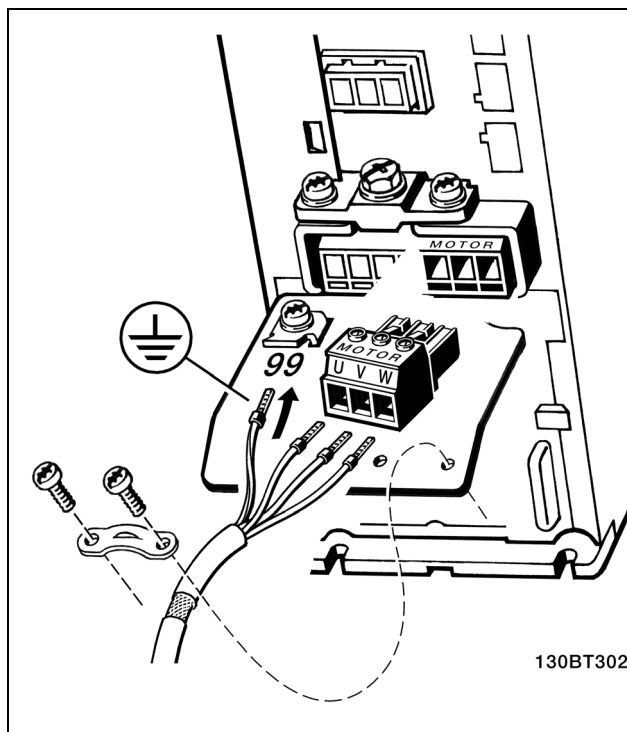

≤ 7.5 kW

— How to Install —

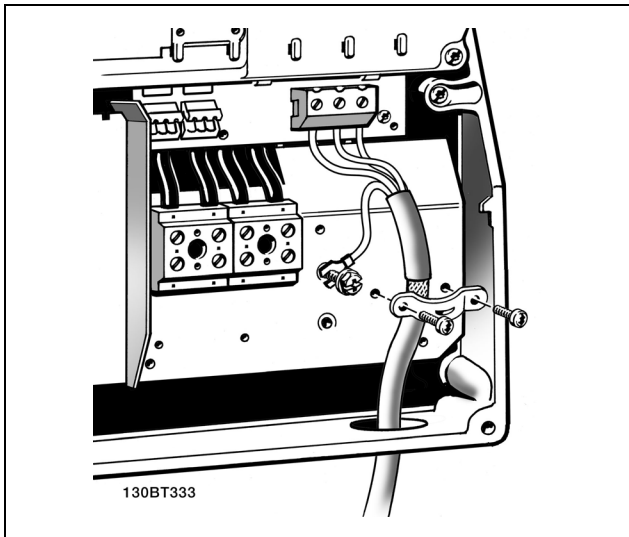

11-22 kW



No.	96	97	98	Motor voltage 0-100% of mains voltage. 3 wires out of motor
	U	V	W	
	U1	V1	W1	6 wires out of motor, Delta-connected
	W2	U2	V2	
	U1	V1	W1	6 wires out of motor, Star-connected U2, V2, W2 to be interconnected separately
No.	99			
	PE			Earth connection

All types of three-phase asynchronous standard motors can be connected to the FC 300. Normally, small motors are star-connected (230/400 V, Δ/Y). Large motors are normally delta-connected (400/690 V, Δ/Y). Refer to the motor name plate for correct connection mode and voltage.

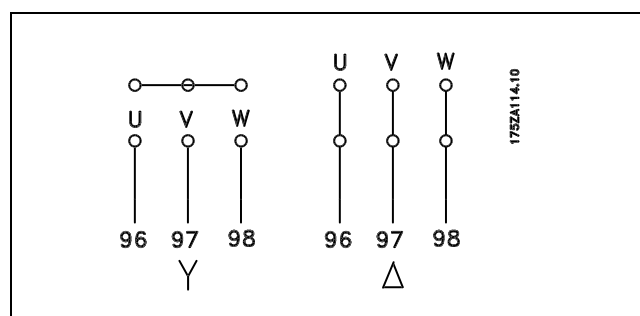

NB!:

In motors without phase insulation paper or other insulation reinforcement suitable for operation with voltage supply (such as a frequency converter), fit an LC filter on the output of the FC 300.

— How to Install —

□ **Motor Cables**

See chapter *General Specifications* for correct dimensioning of motor cable cross-section and length.

- Use a screened/armoured motor cable to comply with EMC emission specifications unless otherwise stated for the RFI filter used.
- Keep the motor cable as short as possible to reduce the noise level and leakage currents.
- Connect the motor cable screen to the decoupling plate of the FC 300 and to the metal cabinet of the motor.
- Make the screen connections with the largest possible surface area (cable clamp). This is done by using the supplied installation devices in the FC 300.
- Avoid mounting with twisted screen ends (pigtailed), which will spoil high frequency screening effects.
- If it is necessary to split the screen to install a motor isolator or motor relay, the screen must be continued with the lowest possible high frequency impedance.



— How to Install —

□ **Fuses**

Branch circuit protection:

In order to protect the installation against electrical and fire hazard, all branch circuits in an installation, switch gear, machines etc., must be shortcircuit and overcurrent protected according to the national/international regulations.

Short circuit protection:

The frequency converter must be protected against short-circuit to avoid electrical or fire hazard. Danfoss recommends using the fuses mentioned below to protect service personnel or other equipment in case of an internal failure in the drive. The frequency converter provides full short circuit protection in case of a short-circuit on the motor output.

Over current protection:

Provide overload protection to avoid fire hazard due to overheating of the cables in the installation. The frequency converter is equipped with an internal over current protection that can be used for upstream overload protection (UL-applications excluded). See par. 4-18. Moreover, fuses or circuit breakers can be used to provide the over current protection in the installation. Over current protection must always be carried out according to national regulations.

Fuses must be designed for protection in a circuit capable of supplying a maximum of 100,000 A_{rms} (symmetrical), 500 V maximum.

Non UL compliance

If UL/cUL is not to be complied with, we recommend using the following fuses, which will ensure compliance with EN50178:

In case of malfunction, not following the recommendation may result in unnecessary damage of the frequency converter.

FC 30X	Max. fuse size	Voltage	Type
K25-K75	10A ¹⁾	200-240 V	type gG
1K1-2K2	20A ¹⁾	200-240 V	type gG
3K0-3K7	32A ¹⁾	200-240 V	type gG
K37-1K5	10A ¹⁾	380-500 V	type gG
2K2-4K0	20A ¹⁾	380-500 V	type gG
5K5-7K5	32A ¹⁾	380-500 V	type gG
11K	63A ¹⁾	380-500 V	type gG
15K	63A ¹⁾	380-500 V	type gG
18K	63A ¹⁾	380-500 V	type gG
22K	80A ¹⁾	380-500 V	type gG

1) Max. fuses - see national/international regulations for selecting an applicable fuse size.

UL Compliance

200-240 V

FC 30X	Bussmann	Bussmann	Bussmann	SIBA	Littel fuse	Ferraz-Shawmut	Ferraz-Shawmut
kW	Type RK1	Type J	Type T	Type RK1	Type RK1	Type CC	Type RK1
2-7.5	KTN-R10	JKS-10	JJN-10	5017906-010	KLN-R10	ATM-R10	A2K-10R
1.1-2.2	KTN-R20	JKS-20	JJN-20	5017906-020	KLN-R20	ATM-R20	A2K-20R
3.0-3.7	KTN-R30	JKS-30	JJN-30	5012406-032	KLN-R30	ATM-R30	A2K-30R

— How to Install —

380-500 V, 525-600 V

FC 30X	Bussmann	Bussmann	Bussmann	SIBA	Littel fuse	Ferraz-Shawmut	Ferraz-Shawmut
kW	Type RK1	Type J	Type T	Type RK1	Type RK1	Type CC	Type RK1
3.7-1.5	KTS-R10	JKS-10	JJS-10	5017906-010	KLS-R10	ATM-R10	A6K-10R
2.2-4.0	KTS-R20	JKS-20	JJS-20	5017906-020	KLS-R20	ATM-R20	A6K-20R
5.5-7.5	KTS-R30	JKS-30	JJS-30	5012406-032	KLS-R30	ATM-R30	A6K-30R
11.0	KTS-R40	JKS-40	JJS-40	5014006-040	KLS-R40		A6K-40R
15.0	KTS-R50	JKS-50	JJS-50	5014006-050	KLS-R50		A6K-50R
18.0	KTS-R60	JKS-60	JJS-60	5014006-063	KLS-R60		A6K-60R
22.0	KTS-R80	JKS-80	JJS-80	5014006-100	KLS-R80		A6K-80R

KTS-fuses from Bussmann may substitute KTN for 240 V frequency converters.
 FWH-fuses from Bussmann may substitute FWX for 240 V frequency converters.
 KLSR fuses from LITTEL FUSE may substitute KLNR fuses for 240 V frequency converters.
 L50S fuses from LITTEL FUSE may substitute L50S fuses for 240 V frequency converters.
 A6KR fuses from FERRAZ SHAWMUT may substitute A2KR for 240 V frequency converters.
 A50X fuses from FERRAZ SHAWMUT may substitute A25X for 240 V frequency converters.



— How to Install —

□ **Access to Control Terminals**

All terminals to the control cables are located underneath the terminal cover on the front of the frequency converter. Remove the terminal cover by means of a screwdriver (see illustration).

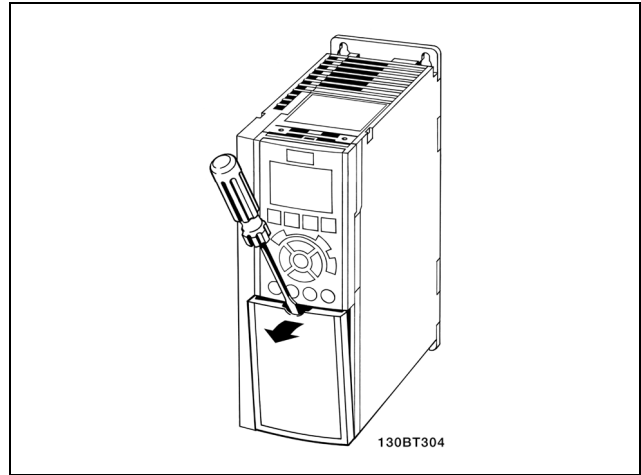

≤ 7.5 kW

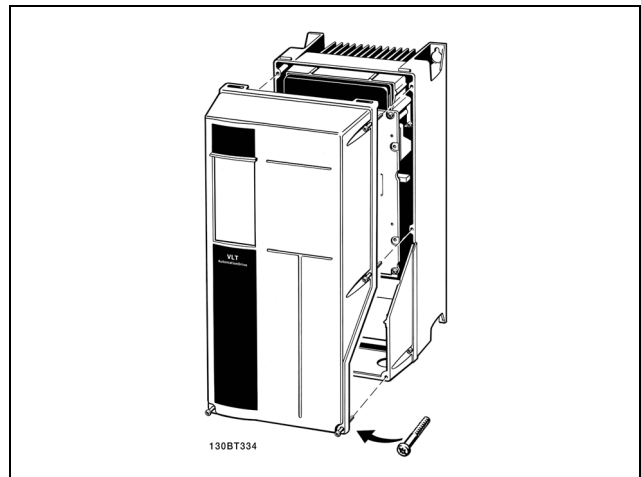

A5, B1 and B2 enclosures

□ **Electrical Installation, Control Terminals**

To mount the cable to the terminal:

1. Strip isolation of 9-10 mm
2. Insert a screw driver in the square hole.
3. Insert the cable in the adjacent circular hole.
4. Remove the screw driver. The cable is now mounted to the terminal.

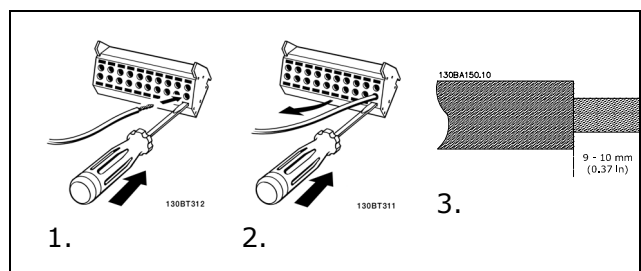

To remove the cable from the terminal:

1. Insert a screw driver in the square hole.
2. Pull out the cable.

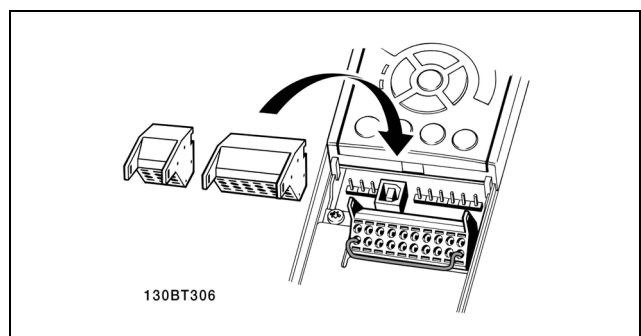

— How to Install —

Assembling of IP55 / NEMA TYPE 12 (A5 housing) with mains disconnect

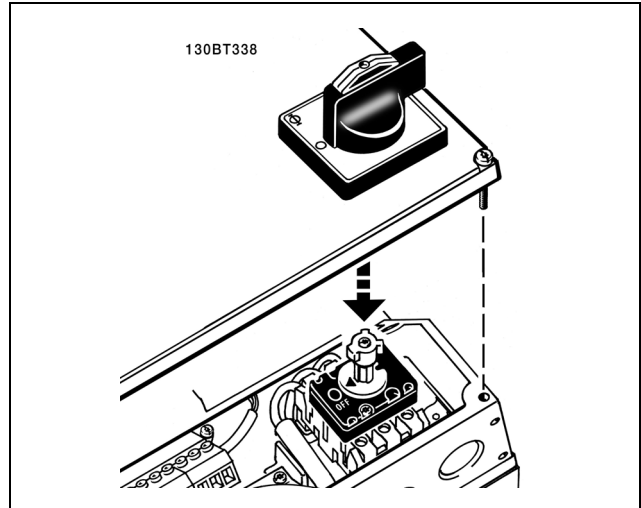

□ **Basic Wiring Example**

1. Mount terminals from the accessory bag to the front of the FC 300.
2. Connect terminals 18, 27 and 37 (FC 302 only) to +24 V (terminal 12/13)

Default settings:

18 = start

27 = coast inverse

37 = safe stop inverse

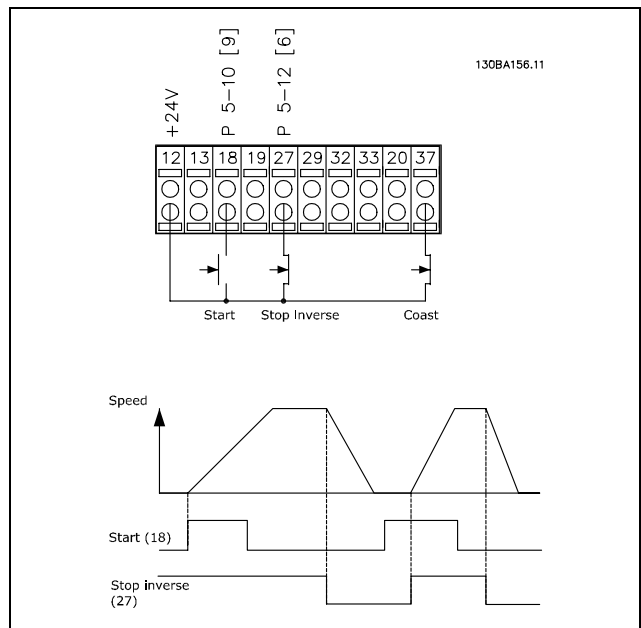

— How to Install —

□ Electrical Installation, Control Cables

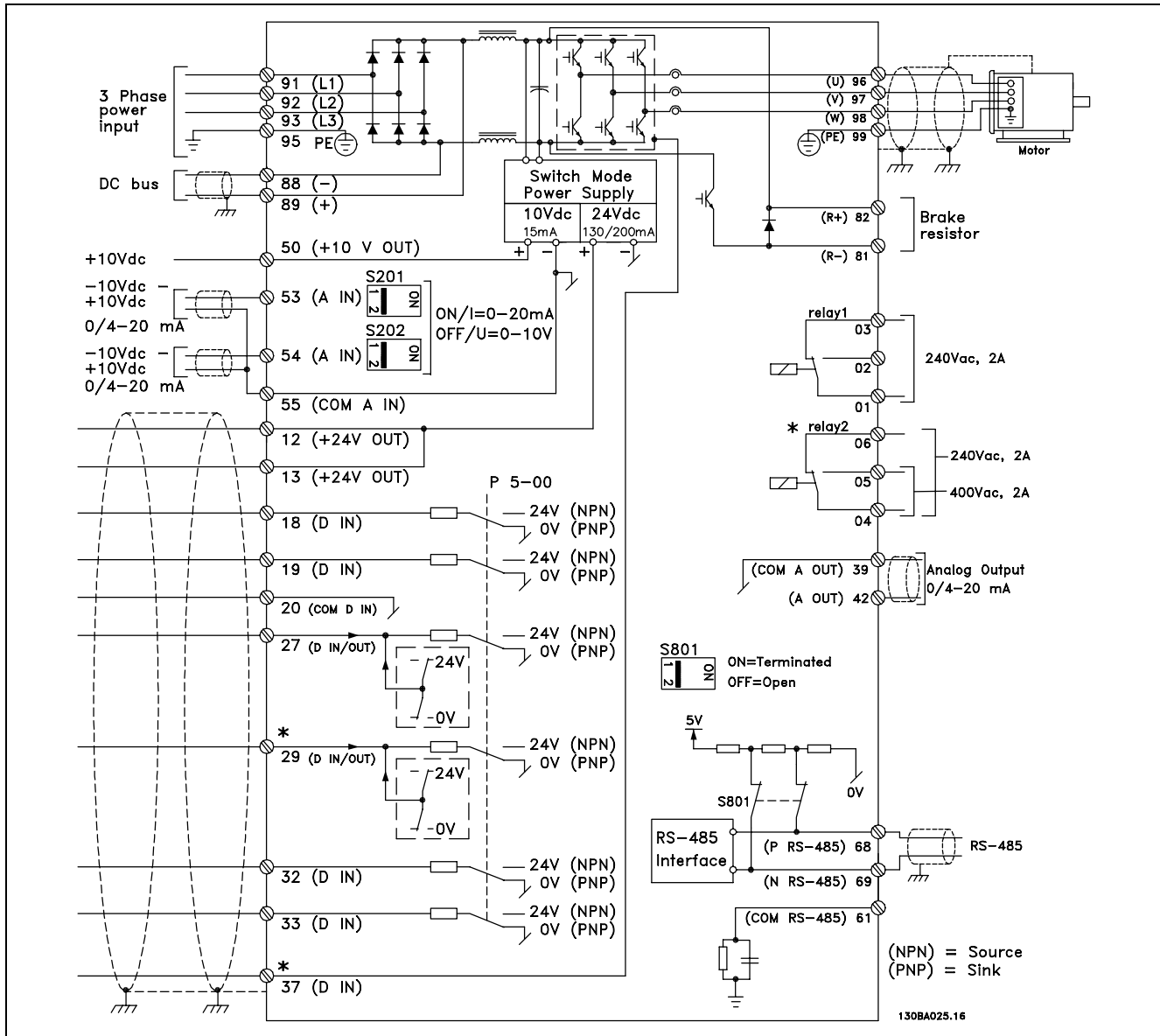

Very long control cables and analog signals may in rare cases and depending on installation result in 50/60 Hz earth loops due to noise from mains supply cables.

If this occurs, you may have to break the screen or insert a 100 nF capacitor between screen and chassis.

Common for the digital and analog in- and outputs must be connected separately to avoid common mode currents from one group (i.e. the digital inputs) to affect other groups (i.e. the analog inputs).

— How to Install —



NB!:
Control cables must be screened/armoured.

1. Use a clamp from the accessory bag to connect the screen to the decoupling plate for control cables.

See section entitled *Earthing of screened/armoured control cables* in the *VLT AutomationDrive FC 300 Design Guide* for the correct termination of control cables.

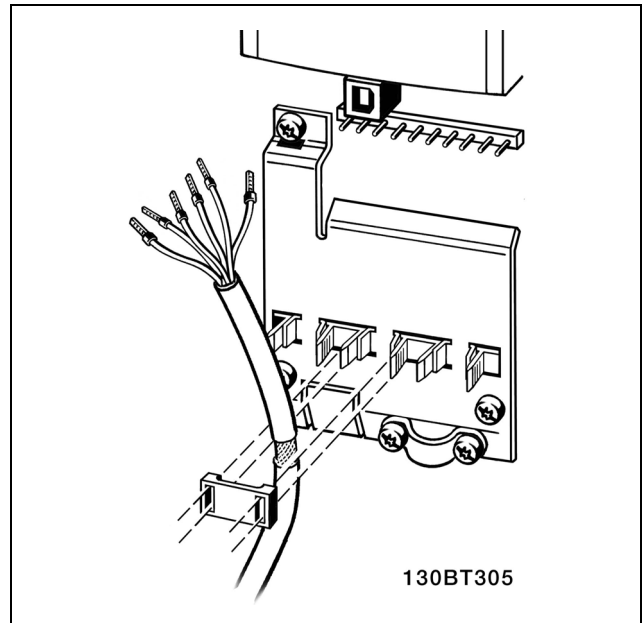

□ **Switches S201, S202, and S801**

Switches S201 (A53) and S202 (A54) are used to select a current (0-20 mA) or a voltage (-10 to 10 V) configuration of the analog input terminals 53 and 54 respectively.

Switch S801 (BUS TER.) can be used to enable termination on the RS-485 port (terminals 68 and 69).

See drawing *Diagram showing all electrical terminals* in section *Electrical Installation*.

Default setting:

- S201 (A53) = OFF (voltage input)
- S202 (A54) = OFF (voltage input)
- S801 (Bus termination) = OFF

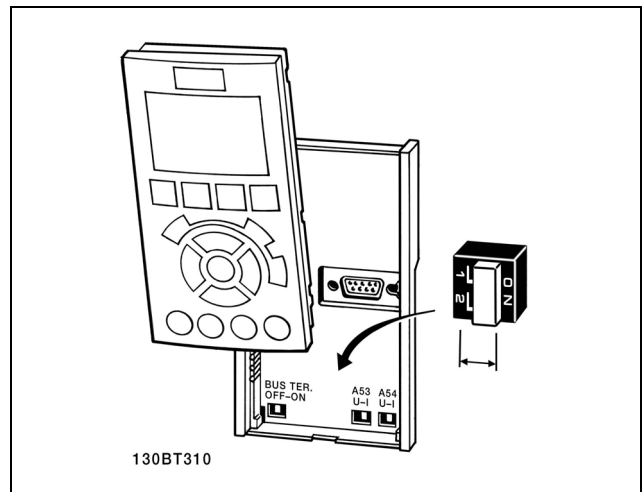

□ **Tightening Torques**

Tighten connected terminals with the following torques:

FC 300	Connections	Torque (Nm)
	Motor, mains, brake, DC Bus, Decoupling Plate screws	0.5-0.6
	Earth, 24 V DC	2-3
	Relay	0.5-0.6

— How to Install —

□ **Final Set-Up and Test**

To test the set-up and ensure that the frequency converter is running, follow these steps.

Step 1. Locate the motor name plate.



NB!:
The motor is either star- (Y) or delta-connected (Δ). This information is located on the motor name plate data.

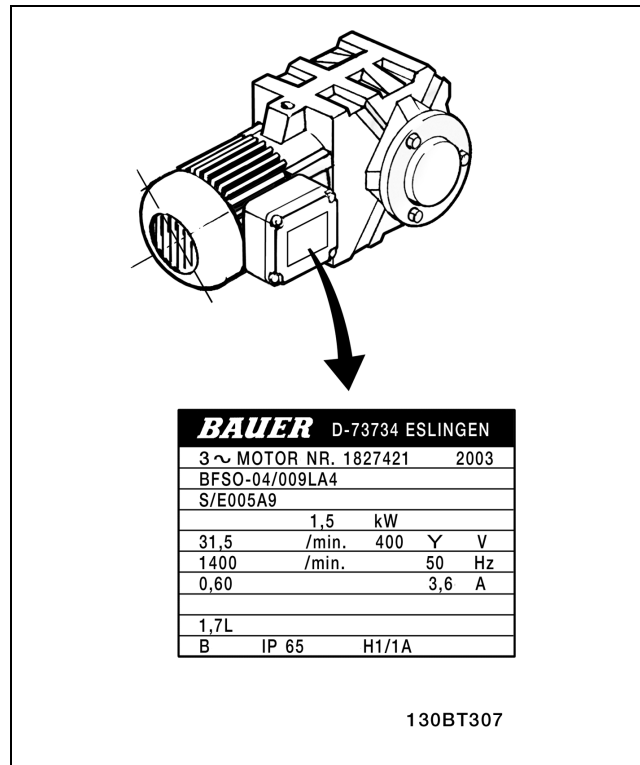

Step 2. Enter the motor name plate data in this parameter list.

To access this list first press the [QUICK MENU] key then select "Q2 Quick Setup".

1.	Motor Power [kW] or Motor Power [HP]	par. 1-20 par. 1-21
2.	Motor Voltage	par. 1-22
3.	Motor Frequency	par. 1-23
4.	Motor Current	par. 1-24
5.	Motor Nominal Speed	par. 1-25

Step 3. Activate the Automatic Motor Adaptation (AMA)

Performing an AMA will ensure optimum performance. The AMA measures the values from the motor model equivalent diagram.

1. Connect terminal 37 to terminal 12 (FC 302).
2. Connect terminal 27 to terminal 12 or set par. 5-12 to 'No function' (par. 5-12 [0]).
3. Activate the AMA par. 1-29.
4. Choose between complete or reduced AMA. If an LC filter is mounted, run only the reduced AMA, or remove the LC filter during the AMA procedure.
5. Press the [OK] key. The display shows "Press [Hand on] to start".
6. Press the [Hand on] key. A progress bar indicates if the AMA is in progress.

— How to Install —

Stop the AMA during operation

1. Press the [OFF] key - the frequency converter enters into alarm mode and the display shows that the AMA was terminated by the user.

Successful AMA

1. The display shows "Press [OK] to finish AMA".
2. Press the [OK] key to exit the AMA state.

Unsuccessful AMA

1. The frequency converter enters into alarm mode. A description of the alarm can be found in the *Troubleshooting* section.
2. "Report Value" in the [Alarm Log] shows the last measuring sequence carried out by the AMA, before the frequency converter entered alarm mode. This number along with the description of the alarm will assist you in troubleshooting. If you contact Danfoss Service, make sure to mention number and alarm description.



NB!:

Unsuccessful AMA is often caused by incorrectly registered motor name plate data or too big difference between the motor power size and the FC 300 power size.



Step 4. Set speed limit and ramp time

Set up the desired limits for speed and ramp time.

Minimum Reference	par. 3-02
Maximum Reference	par. 3-03

Motor Speed Low Limit	par. 4-11 or 4-12
Motor Speed High Limit	par. 4-13 or 4-14

Ramp-up Time 1 [s]	par. 3-41
Ramp-down Time 1 [s]	par. 3-42

□ Additional Connections

□ 24 V Back-up Option

Terminal numbers:

Terminal 35: - external 24 V DC supply.

Terminal 36: + external 24 V DC supply.

1. Attach 24 V DC cable to the 24 V plug connector.
2. Insert plug connector into terminals labelled 35, 36.

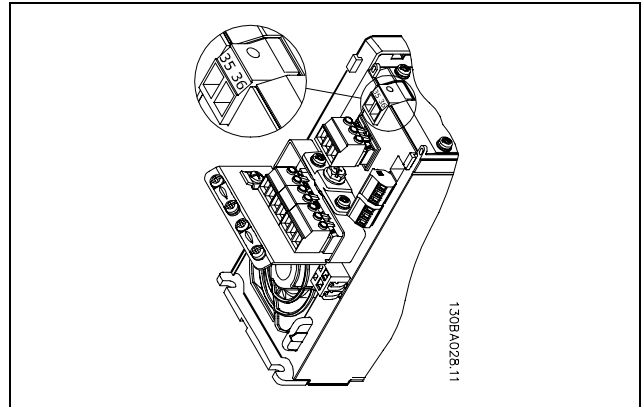

Connection to 24 V back-up supply (≤ 7.5 kW).

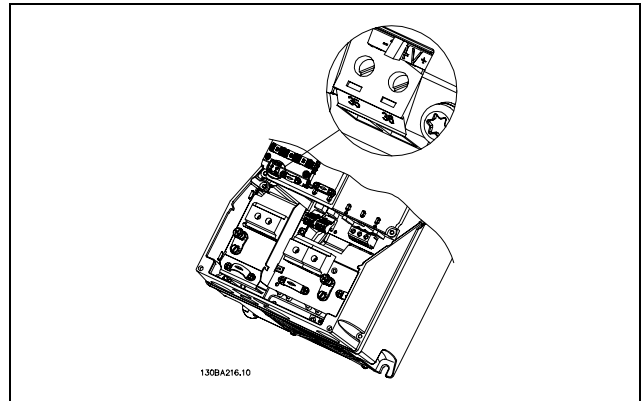

Connection to 24 V back-up supply (11-22 kW).



— How to Install —

□ **Mounting of Option Modules in Slot B (MCB 101 and MCB 102)**

The power to the frequency converter must be disconnected.

- Remove the LCP (Local Control Panel), the terminal cover, and the LCP frame from the frequency converter.
- Fit the MCB10x option card into slot B.
- Connect the control cables and relieve the cable by the enclosed cable strips.
* Remove the knock out in the extended LCP frame, so that the option will fit under the extended LCP frame.
- Fit the extended LCP frame and terminal cover.
- Fit the LCP or blind cover in the extended LCP frame.
- Connect power to the frequency converter.
- Set up the input/output functions in the corresponding parameters, as mentioned in the section *General Technical Data*.

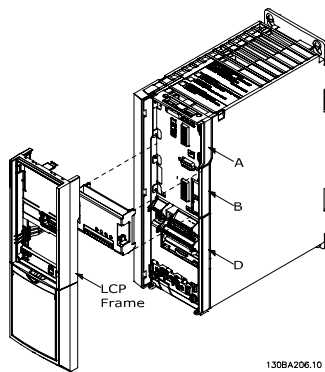

0.25 - 7.5 kW IP20

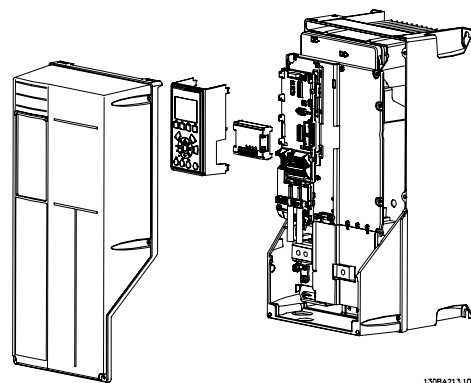

0.25 - 7.5 kW IP 55
and
11 - 22 kW IP21



□ **General Purpose Input Output Module MCB 101**

MCB 101 is used for extension of digital and analog inputs and outputs of FC 301 and FC 302 AutomationDrive.

Contents: MCB 101 must be fitted into slot B in the AutomationDrive.

- MCB 101 option module
- Extended fixture for LCP
- Terminal cover

130BA208.10	MCB 101											FC Series
	General Purpose I/O											B slot
	SW, ver. XX,XX											Code No. 130BXXXX
	COM	DIN	DIN7	DIN8	DIN9	GND(1)	DOUT3	DOUT4	AOUT2	24V	GND(2)	AIN3
X30/	1	2	3	4	5	6	7	8	9	10	11	12

— How to Install —

□ **Galvanic Isolation In the MCB 101**

Digital/analog inputs are galvanically isolated from other inputs/outputs on the MCB 101 and in the control card of the drive. Digital/analog outputs in the MCB 101 are galvanically isolated from other inputs/outputs on the MCB 101, but not from these on the control card of the drive.

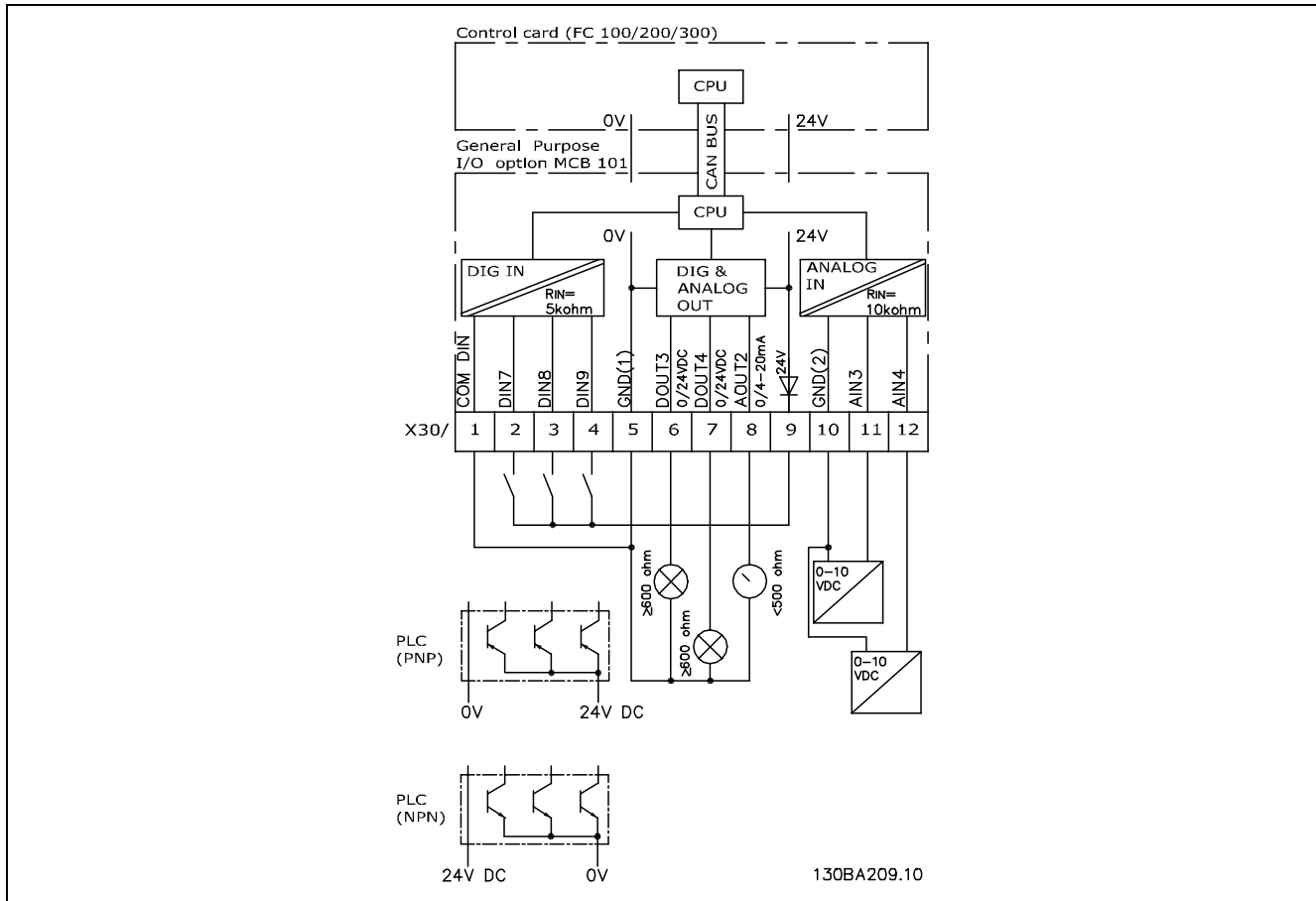

Principle Diagram

□ **Digital inputs - Terminal X30/1-4**

Parameters for set-up: 5-16, 5-17 and 5-18

Number of digital inputs	Voltage level	Voltage levels	Input impedance	Max. load
3	0-24 V DC	PNP type: Common = 0 V Logic "0": Input < 5 V DC Logic "1": Input > 10 V DC NPN type: Common = 24 V Logic "0": Input > 19 V DC Logic "1": Input < 14 V DC	Approx. 5 K ohm	± 28 V continuous ± 37 V in minimum 10 sec.

— How to Install —

□ **Encoder Option MCB 102**

The encoder module is used for interfacing feedback from motor or process. Parameter settings in group 17-xx

Used for:

- VVC plus closed loop
- Flux Vector Speed control
- Flux Vector Torque control
- Permanent magnet motor with SinCos feedback (Hyperface®)

Incremental encoder: 5 V TTL type

SinCos Encoder: Stegmann/SICK (Hyperface®)

Selection of parameters in par. 17-1* and par. 1-02

When the encoder option kit is ordered separately the kit includes:

- Encoder module MCB 102
- Enlarged LCP fixture and enlarged terminal cover

The encoder option does not support FC 302 frequency converters manufactured before week 50/2004.

Min. software version: 2.03 (par. 15-43)

Connector Designation	Incremental Encoder	SinCos Encoder Hyperface®	Description
X31			
1	NC		24 V Output
2	NC		8 V Output
3	5 VCC		5 V Output
4	GND		GND
5	A input	+COS	A input
6	A inv input	REFCOS	A inv input
7	B input	+SIN	B input
8	B inv input	REFSIN	B inv input
9	Z input	+Data RS485	Z input OR +Data RS485
10	Z inv input	-Data RS485	Z input OR -Data RS485
11	NC	NC	Future use
12	NC	NC	Future use

Max. 5V on X31.5-12

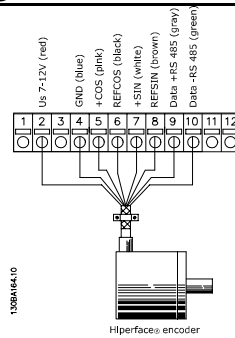
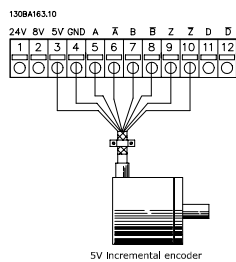

— How to Install —

□ **Load Sharing**

With load sharing you can connect several FC 300's DC intermediate circuits if you extend the installation using extra fuses and AC coils (see illustration).

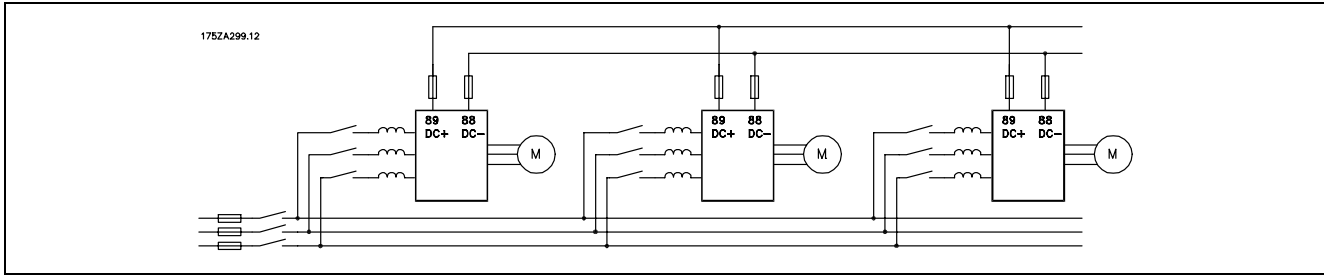

NB!:

Load sharing cables must be screened/armoured. If an unscreened/unarmoured cable is used, some EMC requirements are not complied with. For more information, see *EMC specifications* in the *VLT AutomationDrive FC 300 Design Guide*.



NB!:

Load sharing calls for extra equipment and safety considerations. For further information, see the Instruction *Load Sharing VLT 5000, MI50NXYY*.



Voltage levels of up to 975 V DC may occur between terminals 88 and 89.

No.	88	89	Loadsharing / DC link
	DC -	DC +	Terminals

— How to Install —

□ **Relay Option MCB 105**

The MCB 105 option includes 3 pieces of SPDT contacts and must be fitted into option slot B.

Electrical Data:

Max terminal load (AC-1) ¹⁾ (Resistive load)	240 V AC 2A
Max terminal load (AC-15) ¹⁾ (Inductive load @ cosφ 0.4)	240 V AC 0.2 A
Max terminal load (DC-1) ¹⁾ (Resistive load)	24 V DC 1 A
Max terminal load (DC-13) ¹⁾ (Inductive load)	24 V DC 0.1 A
Min terminal load (DC)	5 V 10 mA
Max switching rate at rated load/min load	6 min ⁻¹ /20 sec ⁻¹

1) IEC 947 part 4 and 5

When the relay option kit is ordered separately the kit includes:

- Relay Module MCB 105
- Enlarged LCP fixture and enlarged terminal cover
- Label for covering access to switches S201, S202 and S801
- Cable strips for fastening cables to relay module

The relay option does not support FC 302 frequency converters manufactured before week 50/2004.
Min. software version: 2.03 (par. 15-43).

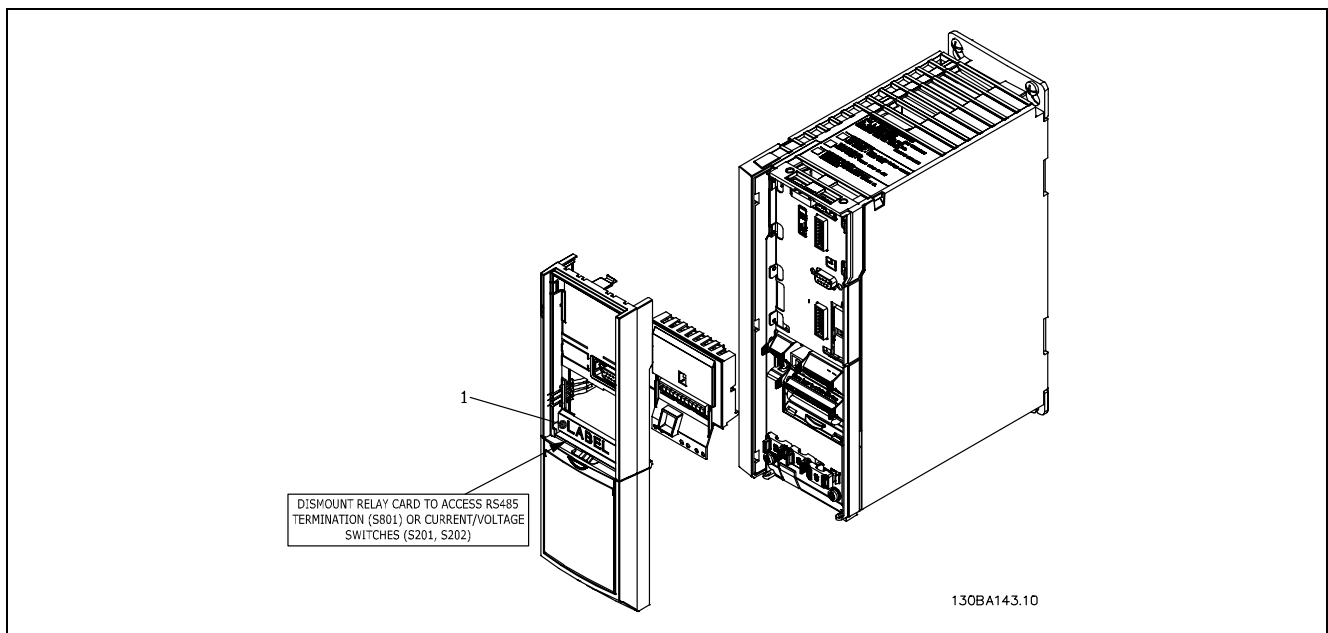

≤ 7.5 kW

IMPORTANT

1. The label **MUST** be placed on the LCP frame as shown (UL approved).



— How to Install —

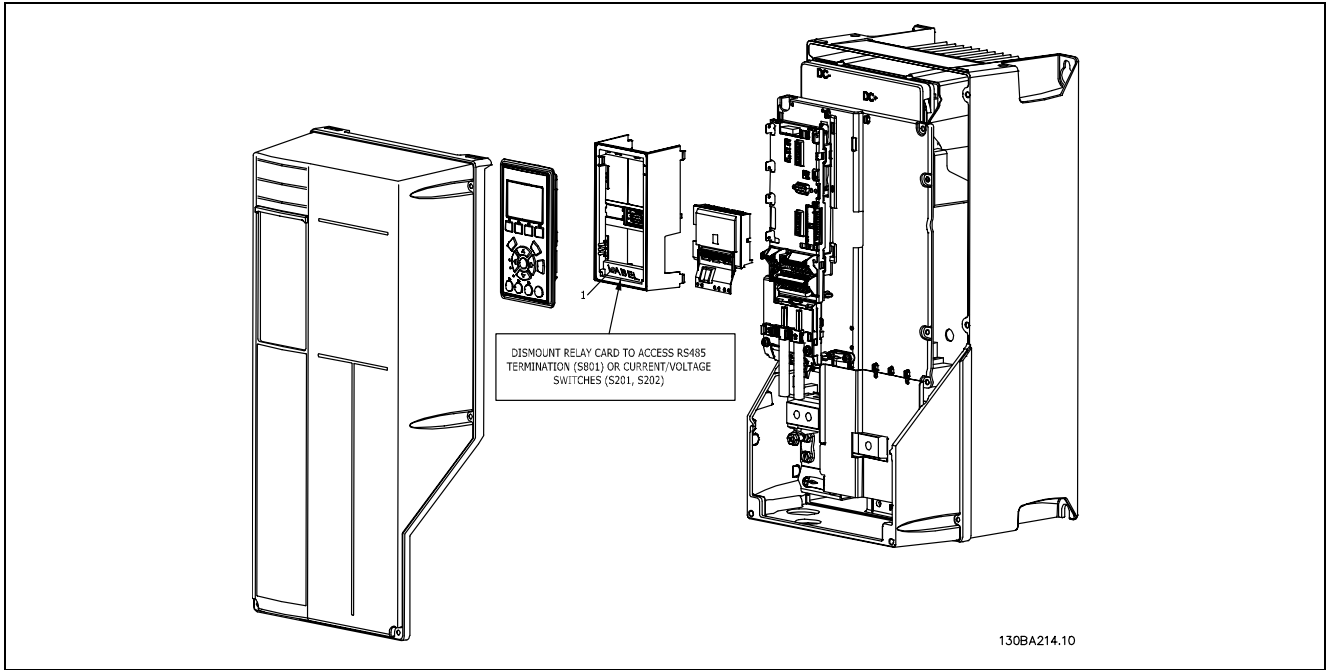

11-22 kW

IMPORTANT

1. The label **MUST** be placed on the LCP frame as shown (UL approved).



Warning Dual supply

— How to Install —

How to add the MCB 105 option:

- The power to the frequency converter must be disconnected.
- The power to the live part connections on relay terminals must be disconnected.
- Remove the LCP, the terminal cover and the LCP fixture from the FC 300x.
- Fit the MCB 105 option in slot B.
- Connect the control cables and fasten the cables with the enclosed cable strips.
- Make sure the length of the stripped wire is correct (see the following drawing).
- Do not mix live parts (high voltage) with control signals (PELV).
- Fit the enlarged LCP fixture and enlarged terminal cover.
- Replace the LCP.
- Connect power to the frequency converter.
- Select the relay functions in par. 5-40 [6-8], 5-41 [6-8] and 5-42 [6-8].

NB (Array [6] is relay 7, array [7] is relay 8, and array [8] is relay 9)

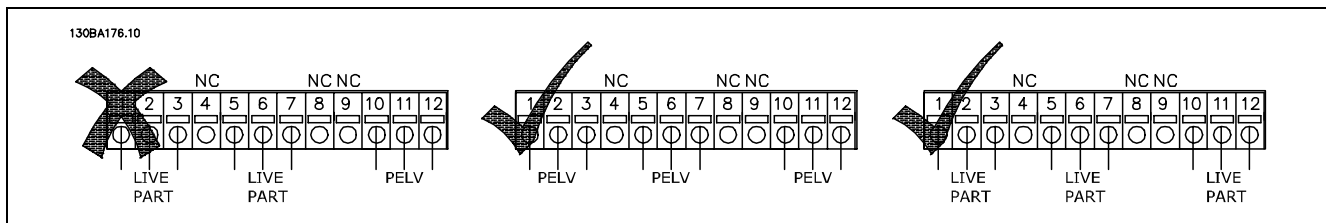
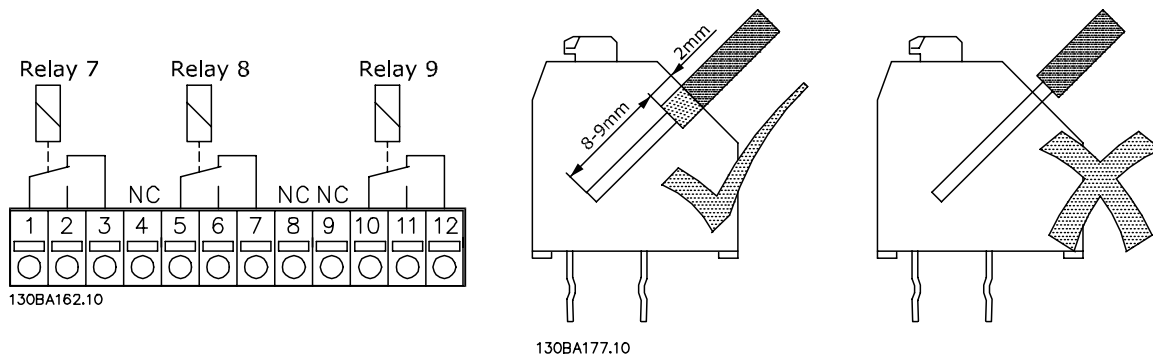

Do not combine low voltage parts and PELV systems.

— How to Install —

□ **Brake Connection Option**

The connection cable to the brake resistor must be screened/armoured.

No.	81	82	Brake resistor
	R-	R+	terminals



NB!:

Dynamic brake calls for extra equipment and safety considerations. For further information, see the Instruction *Brake Resistors for Horizontal Applications*, MI50SXYY.

1. Use cable clamps to connect the screen to the metal cabinet of the frequency converter and to the decoupling plate of the brake resistor.
2. Dimension the cross-section of the brake cable to match the brake current.



NB!:

Voltages up to 975 V DC (@ 600 V AC) may occur between the terminals.



NB!:

If a short circuit in the brake IGBT occurs, prevent power dissipation in the brake resistor by using a mains switch or contactor to disconnect the mains for the frequency converter. Only the frequency converter shall control the contactor.

□ **Relay Connection**

To set relay output, see par. group 5-4* Relays.

No.	01 - 02	make (normally open)
	01 - 03	break (normally closed)
	04 - 05	make (normally open)
	04 - 06	break (normally closed)

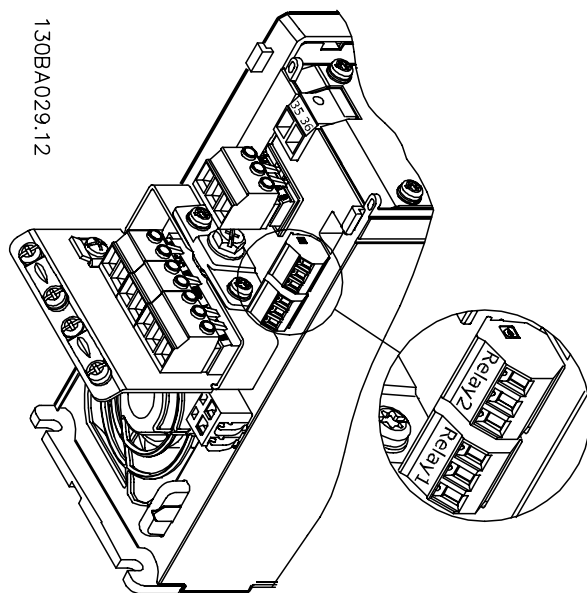

Terminals for relay connection (≤ 7.5 kW).

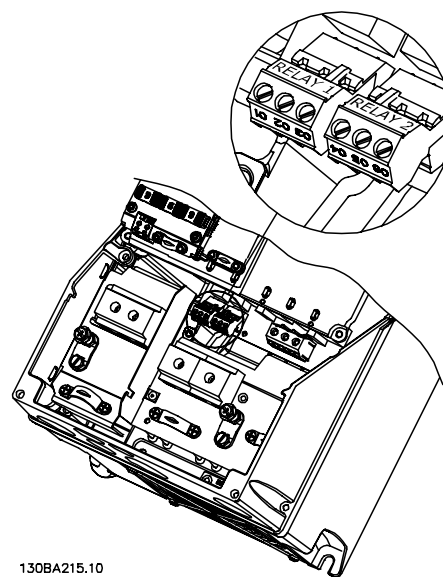

Terminals for relay connection (11-22 kW).

— How to Install —

□ Control of Mechanical Brake

In hoisting/lowering applications, you need to be able to control an electro-mechanical brake.

- Control the brake using any relay output or digital output (terminal 27 or 29).
- Keep the output closed (voltage-free) as long as the frequency converter is unable to 'support' the motor, for example due to the load being too heavy.
- Select *Mechanical brake control* [32] in par. 5-4* for applications with an electro-mechanical brake.
- The brake is released when the motor current exceeds the preset value in par. 2-20.
- The brake is engaged when the output frequency is less than the frequency set in par. 2-21 or 2-22, and only if the frequency converter carries out a stop command.

If the frequency converter is in alarm mode or in an overvoltage situation, the mechanical immediately brake cuts in.

□ Parallel Connection of Motors

The FC 300 is able to control several parallel-connected motors. The total current consumption of the motors must not exceed the rated output current I_{INV} for the FC 300.

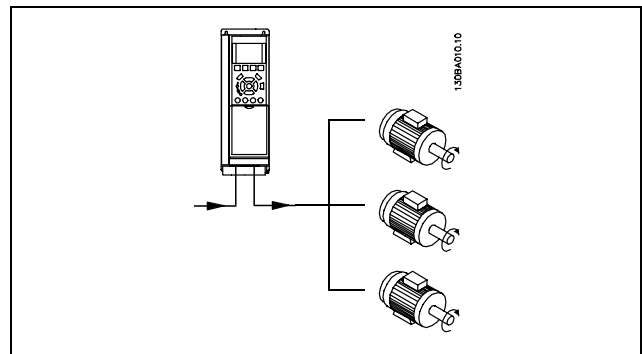

Problems may arise at start and at low RPM values if motor sizes are widely different because small motors' relatively high ohmic resistance in the stator calls for a higher voltage at start and at low RPM values.

The electronic thermal relay (ETR) of the FC 300 cannot be used as motor protection for the individual motor in systems with motors connected in parallel. Further motor protection must be provided, e.g. thermistors in each motor or individual thermal relays. (Circuit breakers are not suitable as protection).



NB!:

When motors are connected in parallel, parameter 1-29 *Automatic motor adaptation (AMA)* cannot be used.

For more information, see *VLT AutomationDrive FC 300 Design Guide*.

□ Motor Thermal Protection

The electronic thermal relay in FC 300 has received the UL-approval for single motor protection, when par. 1-90 *Motor Thermal Protection* is set for *ETR Trip* and par. 1-24 *Motor current*, $I_{M,N}$ is set to the rated motor current (see motor name plate).

— How to Install —



How to Programme

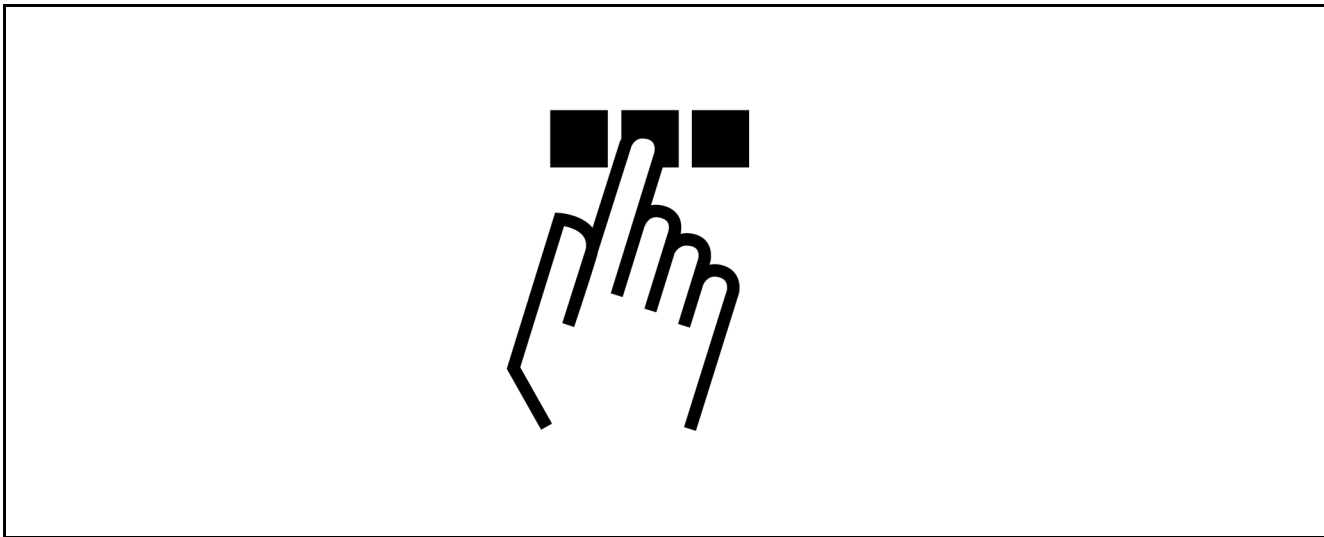

□ **How to Programme on the Graphical Local Control Panel**

The following instructions are valid for the graphical LCP (LCP 102):

The control panel is divided into four functional groups:

1. Graphical display with Status lines.
2. Menu keys and indicator lights - changing parameters and switching between display functions.
3. Navigation keys and indicator lights (LEDs).
4. Operation keys and indicator lights (LEDs).

All data is displayed in a graphical LCP display, which can show up to five items of operating data while displaying [Status].

Display lines:

- a. **Status line:** Status messages displaying icons and graphic.
- b. **Line 1-2:** Operator data lines displaying data defined or chosen by the user. By pressing the [Status] key, up to one extra line can be added.
- c. **Status line:** Status messages displaying text.

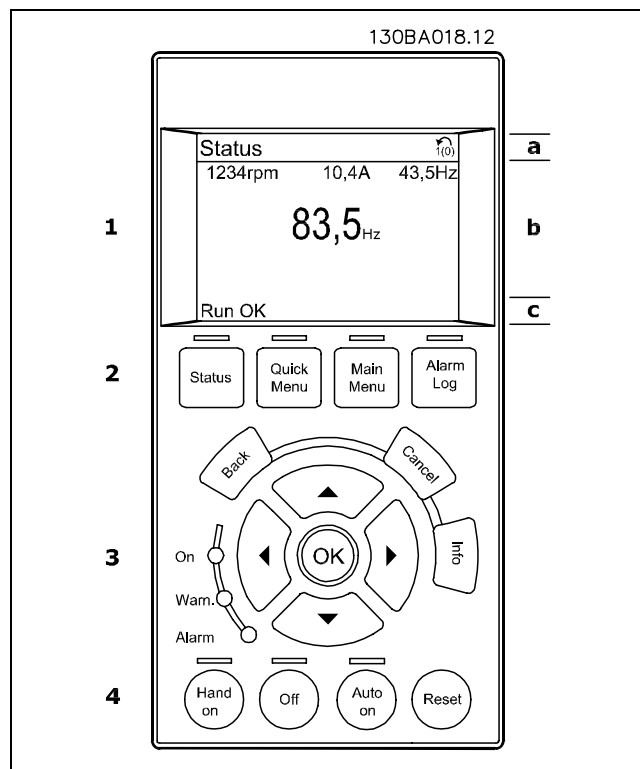

The LCD-display has back light and a total of 6 alpha-numeric lines. The display lines show the direction of rotation (arrow), the chosen Set-up as well as the programming Set-up. The display is divided into 3 sections:

— How to Programme —

Top section shows up to 2 measurements in normal operating status.

The top line in the **Middle section** shows up to 5 measurements with related unit, regardless of status (except in the case of alarm/warning).

Bottom section always shows the state of the frequency converter in Status mode.

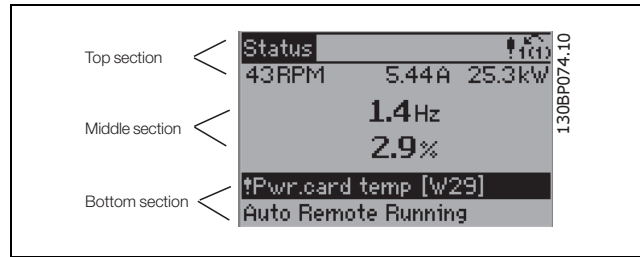

The Active Set-up (selected as the Active Set-up in par. 0-10) is shown. When programming another Set-up than the Active Set-up, the number of the programmed Set-up appears to the right.

Display Contrast Adjustment

Press [status] and [▲] for darker display
 Press [status] and [▼] for brighter display

Most FC 300 parameter set-ups can be changed immediately via the control panel, unless a password has been created via par. 0-60 *Main Menu Password* or via par. 0-65 *Quick Menu Password*.

Indicator lights (LEDs):

If certain threshold values are exceeded, the alarm and/or warning LED lights up. A status and alarm text appear on the control panel. The on LED is activated when the frequency converter receives mains voltage or via a DC bus terminal or 24 V external supply. At the same time, the back light is on.

- Green LED/On: Control section is working.
- Yellow LED/Warn.: Indicates a warning.
- Flashing Red LED/Alarm: Indicates an alarm.



LCP keys

The control keys are divided into functions. The keys below the display and indicator lamps are used for parameter Set-up, including choice of display indication during normal operation.

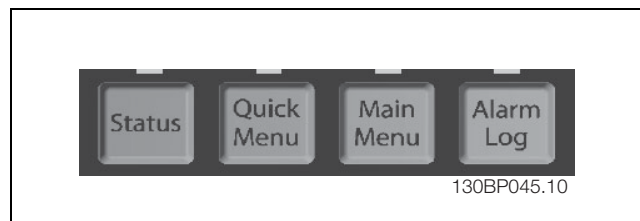

[Status] indicates the status of the frequency converter and/or the motor. You can choose between 3 different readouts by pressing the [Status] key:
 5 line readouts, 4 line readouts or Smart Logic Control.
 Use **[Status]** for selecting the mode of display or for changing back to Display mode from either the Quick Menu mode, the Main Menu mode or Alarm mode. Also use the [Status] key to toggle single or double read-out mode.

— How to Programme —

[Quick Menu] allows quick access to different Quick Menus such as:

- My Personal Menu
- Quick Set-up
- Changes Made
- Loggings

Use **[Quick Menu]** for programming the parameters belonging to the Quick Menu. It is possible to switch directly between Quick Menu mode and Main Menu mode.

[Main Menu] is used for programming all parameters.

It is possible to switch directly between Main Menu mode and Quick Menu mode.

Parameter shortcut can be carried out by pressing down the **[Main Menu]** key for 3 seconds.

The parameter shortcut allows direct access to any parameter.

[Alarm Log] displays an Alarm list of the five latest alarms (numbered A1-A5). To obtain additional details about an alarm, use the arrow keys to manoeuvre to the alarm number and press [OK]. You will now receive information about the condition of your frequency converter right before entering the alarm mode.

[Back] takes you to the previous step or layer in the navigation structure.

[Cancel] annuls your last change or command as long as the display has not been changed.

[Info] supplies information about a command, parameter, or function in any display window. [Info] provides detailed information whenever help is needed.

Exit info mode by pressing either [Info], [Back], or [Cancel].



Navigation Keys

The four navigation arrows are used to navigate between the different choices available in **[Quick Menu]**, **[Main Menu]** and **[Alarm Log]**. Use the keys to move the cursor.

[OK] is used for choosing a parameter marked by the cursor and for enabling the change of a parameter.

Local Control Key for local control are found at the bottom of the control panel.

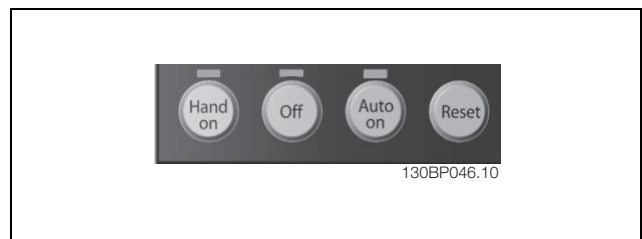

[Hand On] enables control of the frequency converter via the LCP. [Hand on] also starts the motor, and it is now possible to enter the motor speed data by means of the arrow keys. The key can be selected as Enable [1] or Disable [0] via par. 0-40 [Hand on] key on LCP.

External stop signals activated by means of control signals or a serial bus will override a "start" command via the LCP.

— How to Programme —

The following control signals will still be active when [Hand on] is activated:

- [Hand on] - [Off] - [Auto on]
- Reset
- Coasting stop inverse
- Reversing
- Set-up select lsb - Set-up select msb
- Stop command from serial communication
- Quick stop
- DC brake

[Off] stops the connected motor. The key can be selected as Enable [1] or Disable [0] via par. 0-41 [Off] key on LCP. If no external stop function is selected and the [Off] key is inactive the motor can be stopped by disconnecting the voltage.

[Auto On] enables the frequency converter is to be controlled via the control terminals and/or serial communication. When a start signal is applied on the control terminals and/or the bus, the frequency converter will start. The key can be selected as Enable [1] or Disable [0] via par. 0-42 [Auto on] key on LCP.



NB!:

An active HAND-OFF-AUTO signal via the digital inputs has higher priority than the control keys [Hand on] – [Auto on].

[Reset] is used for resetting the frequency converter after an alarm (trip). It can be selected as Enable [1] or Disable [0] via par. 0-43 Reset Keys on LCP.

The parameter shortcut can be carried out by holding down the [Main Menu] key for 3 seconds. The parameter shortcut allows direct access to any parameter.

□ **Quick Transfer of Parameter Settings**

Once the set-up of a drive is complete, we recommend that you store the data in the LCP or on a PC via MCT 10 Set-up Software Tool.

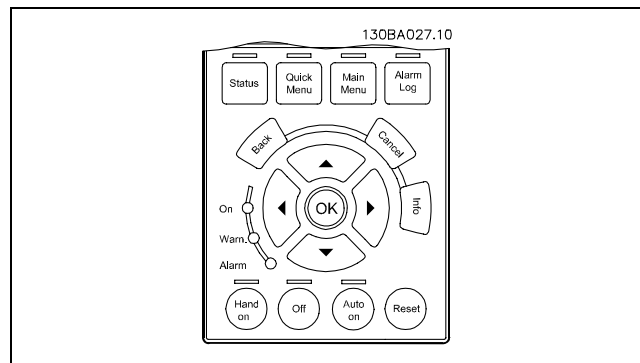

Data storage in LCP:

1. Go to par. 0-50 LCP Copy
2. Press the [OK] key
3. Select "All to LCP"
4. Press the [OK] key

All parameter settings are now stored in the LCP indicated by the progress bar. When 100% is reached, press [OK].



NB!:

Stop the motor before performing this operation.

— How to Programme —

You can now connect the LCP to another frequency converter and copy the parameter settings to this frequency converter as well.

Data transfer from LCP to drive:

1. Go to par. 0-50 *LCP Copy*
2. Press the [OK] key
3. Select "All from LCP"
4. Press the [OK] key

The parameter settings stored in the LCP are now transferred to the drive indicated by the progress bar. When 100% is reached, press [OK].

**NB!:**

Stop the motor before performing this operation.

□ **Reset to Default Setting**

To restore all parameter values to their default setting go to par. 14-22 *Operating Mode* and select Initialisation. Power down the frequency converter. The frequency converter will automatically restore to default settings during the next power up.

□ **Adjust Display Contrast**

Hold down [STATUS] and use the up or down navigation arrow to adjust the display contrast



□ Connection Examples

□ Start/Stop

Terminal 18 = start/stop par. 5-10 [8] *Start*
 Terminal 27 = No operation par. 5-12 [0] *No operation* (Default *coast inverse*)
 Terminal 37 = Safe stop (FC 302 only)

Par. 5-10 *Digital Input* = *Start* (default)
 Par. 5-12 *Digital Input* = *coast inverse* (default)

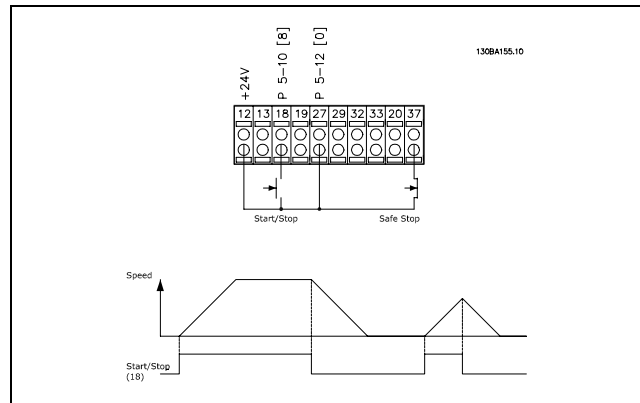

□ Pulse Start/Stop

Terminal 18 = start/stop par. 5-10 [9] *Latched start*
 Terminal 27 = Stop par. 5-12 [6] *Stop inverse*
 Terminal 37 = Coasting stop (safe)

Par. 5-10 *Digital Input* = *Latched start*
 Par. 5-12 *Digital Input* = *Stop inverse*

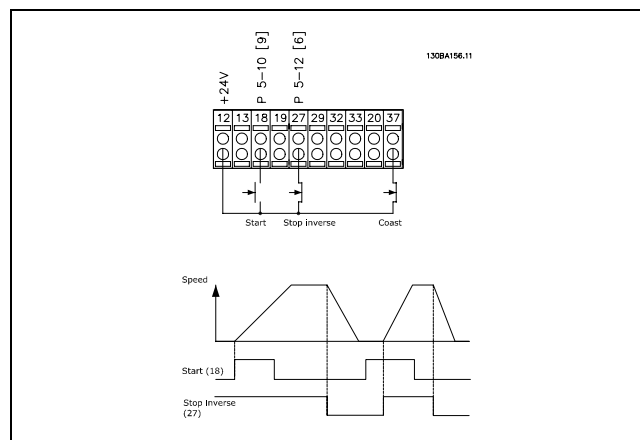

□ Speed Up/Down

Terminals 29/32 = Speed up/down.

Par. 5-10 *Digital Input* = *Start*(default)
 Par. 5-12 *Digital input* = *Freeze reference*
 Par. 5-13 *Digital input* = *Speed up*
 Par. 5-14 *Digital input* = *Speed down*

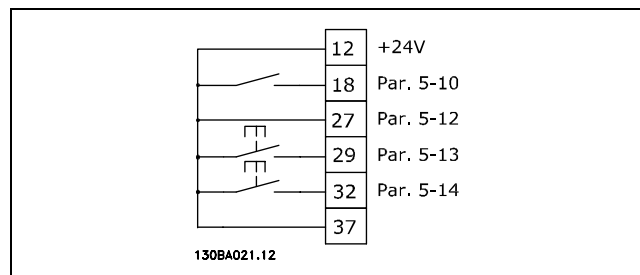

□ Potentiometer Reference

Voltage reference via a potentiometer.

Par. 3-15 *Reference Resource 1* [1]
 = *Analog Input 53*
 Par. 6-10 *Terminal 53, Low Voltage* = 0 Volt
 Par. 6-11 *Terminal 53, High Voltage* = 10 Volt
 Par. 6-14 *Terminal 53, Low Ref./Feedb. Value* = 0 RPM
 Par. 6-15 *Terminal 53, High Ref./Feedb. Value* = 1.500 RPM
 Switch S201 = OFF (U)

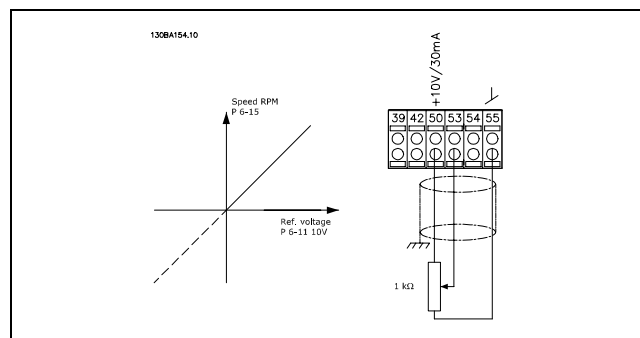

□ **Basic Parameters**

0-01 Language

Option:

*English (ENGLISH)	[0]
German (DEUTSCH)	[1]
French (FRANCAIS)	[2]
Danish (DANSK)	[3]
Spanish (ESPAÑOL)	[4]
Italian (ITALIANO)	[5]
Chinese (CHINESE)	[10]
Finnish (FINNISH)	[20]
English US (ENGLISH US)	[22]
Greek (GREEK)	[27]
Portuguese (PORTUGUESE)	[28]
Slovenian (SLOVENIAN)	[36]
Korean (KOREAN)	[39]
Japanese (JAPANESE)	[40]
Turkish (TURKISH)	[41]
Traditional Chinese	[42]
Bulgarian	[43]
Serbian	[44]
Romanian (ROMANIAN)	[45]
Hungarian (HUNGARIAN)	[46]
Czech	[47]
Polish (POLISH)	[48]
Russian	[49]
Thai	[50]
Bahasa Indonesian (BAHASA INDONESIAN)	[51]

Function:

Defines the language to be used in display.

The frequency converter can be delivered with 4 various language packages. English and German are included in all packages. English cannot be erased or manipulated.

1-20 Motor Power [kW]

Range:

0.37-7.5 kW [M-TYPE]

Function:

The value should equal the nameplate data on the connected motor. The default value corresponds to the nominal rated output of the unit.

1-22 Motor Voltage

Range:

200-600 V [M-TYPE]

Function:

The value should equal the nameplate data on the connected motor. The default value corresponds to the nominal rated output of the unit.

1-23 Motor Frequency

Option:

*50 Hz (50 HZ)	[50]
60 Hz (60 HZ)	[60]
Min - Max motor frequency: 20 - 300 Hz	

Function:

Select the stated value from the motor name plate. Alternatively, set the value for motor frequency to be infinitely variable. If a value different from 50 Hz or 60 Hz is selected, it is necessary to correct par. 1-50 to 1-53. For 87 Hz operation with 230/400 V motors, set the nameplate data for 230 V/50 Hz. Adapt par. 4-13 *Motor Speed High Limit [RPM]* and par. 3-03 *Maximum Reference* to the 87 Hz application.

1-24 Motor Current

Range:

Motor type dependent.

Function:

The value should equal the nameplate data on the connected motor. Data is used for calculating torque, motor protection etc.

1-25 Motor Nominal Speed

Range:

100 - 60000 RPM * RPM

Function:

The value should equal the name plate data on the connected motor. The data is used for calculating motor compensations.

1-29 Automatic Motor Adaptation (AMA)

Option:

*OFF	[0]
Enable complete AMA	[1]
Enable reduced AMA	[2]

Function:

If the AMA function is used, the frequency converter automatically sets the necessary motor parameters (par. 1-30 to par. 1-35) with the motor stationary. AMA ensures optimum use of the motor. For the best adaptation of the frequency converter, run AMA on a cold motor. Select *Enable complete AMA*, if the frequency converter is to carry out AMA of the stator



* default setting () display text [] value for use in communication via serial communication port

— How to Programme —

resistance R_s , the rotor resistance R_r , the stator leakage reactance x_1 , the rotor leakage reactance X_2 and the main reactance X_h .

FC 301: The Complete AMA does not include X_h measurement, but the X_h value is determined from the motor database. Par. 1-35 may be adjusted to obtain optimal start performance. Select *Reduced AMA* if a reduced test is to be carried out, in which only the stator resistance R_s in the system is determined. AMA cannot be carried out while the motor is running.

AMA cannot be carried out on permanent magnet motors.

Activate the AMA function by pressing [Hand on] after selecting [1] or [2]. See also section *Automatic Motor Adaptation*. After a normal sequence, the display will read, "Press [OK] to finish AMA". After pressing the [OK] key the frequency converter is now ready for operation.



NB!:

It is important to set motor par. 1-2* correctly, since these form part of the AMA algorithm. For optimum dynamic motor performance, an AMA must be carried out. It may take up to 10 min, depending on the power rating of the motor.



NB!:

Avoid externally generating torque during AMA.



NB!:

If one of the settings in par. 1-2* is changed, par. 1-30 to 1-39 will return to default setting.

3-02 Minimum Reference

Range:

-100000.000 - par. 3-03 *0.000 Unit

Function:

The *Minimum reference* is the minimum value obtained by the sum of all references. *Minimum reference* is only active if *Min - Max* [0] is set in par. 3-00. Speed control, closed loop: RPM Torque control, speed feedback: Nm

3-03 Maximum Reference

Range:

Par. 3-02 - 100000.000 *1500.000 Unit

Function:

The *Maximum reference* is the highest value obtained by the sum of all references. The unit follows the choice of configuration in par. 1-00. Speed control, closed loop: RPM Torque control, speed feedback: Nm.

3-41 Ramp 1 Ramp up Time

Range:

0.01 - 3600.00 s * s

Function:

The ramp-up time is the acceleration time from 0 RPM to the rated motor speed $n_{M,N}$ (par. 1-25), provided that the output current does not reach the torque limit (set in par. 4-16). The value 0.00 corresponds to 0.01 s in speed mode.

$$Par. 3 - 41 = \frac{t_{acc} * n_{norm} [par. 1 - 25]}{\Delta ref [RPM]} [s]$$

3-42 Ramp 1 Ramp Down Time

Range:

0.01 - 3600.00 s * s

Function:

The ramp-down time is the deceleration time from the rated motor speed $n_{M,N}$ (par. 1-25) to 0 RPM, provided that there is no over-voltage in the inverter due to regenerative operation of the motor, or if the generated current reaches the torque limit (set in par. 4-17). The value 0.00 corresponds to 0.01 s in speed mode. See ramp-up time in par. 3-41.

$$Par. 3 - 42 = \frac{t_{acc} * n_{norm} [par. 1 - 25]}{\Delta ref [RPM]} [s]$$

* default setting () display text [] value for use in communication via serial communication port

Parameter Lists

Changes during operation

“TRUE” means that the parameter can be changed while the frequency converter is in operation and “FALSE” means that the it must be stopped before a change can be made.

4-Set-up

‘All set-up’: the parameters can be set individually in each of the four set-ups, i.e. one single parameter can have four different data values.

‘1 set-up’: data value will be the same in all set-ups.

Conversion index

This number refers to a conversion figure used when writing or reading by means of a frequency converter.

Conv. index	100	67	6	5	4	3	2	1	0	-1	-2	-3	-4	-5	-6
Conv. factor	1	1/60	1000000	100000	10000	1000	100	10	1	0.1	0.01	0.001	0.0001	0.00001	0.000001

Data type	Description	Type
2	Integer 8	Int8
3	Integer 16	Int16
4	Integer 32	Int32
5	Unsigned 8	UInt8
6	Unsigned 16	UInt16
7	Unsigned 32	UInt32
9	Visible String	VisStr
33	Normalized value 2 bytes	N2
35	Bit sequence of 16 boolean variables	V2
54	Time difference w/o date	TimD

See the *FC 300 Design Guide* for further information about data types 33, 35 and 54.



— How to Programme —

□ 0-*** Operation/Display

Par. No. #	Parameter description	Default value	4-set-up	FC 302 series	Change during operation	Conversion index	Type
0-0* Basic Settings							
0-01	Language	[0] English	1 set-up		TRUE	-	Uint8
0-02	Motor Speed Unit	[0] RPM	2 set-ups		FALSE	-	Uint8
0-03	Regional Settings	[0] International	2 set-ups		FALSE	-	Uint8
0-04	Operating State at Power-up (Hand)	[1] Forced stop, ref=old	All set-ups		TRUE	-	Uint8
0-1* Set-up Handling							
0-10	Active Set-up	[1] Setup 1	1 set-up		TRUE	-	Uint8
0-11	Edit Set-up	[1] Setup 1	All set-ups		TRUE	-	Uint8
0-12	This Set-up Linked to	[0] Not linked	All set-ups		FALSE	-	Uint8
0-13	Readout: Linked Set-ups	0 N/A	All set-ups		FALSE	0	Uint16
0-14	Readout: Edit Set-ups / Channel	0 N/A	All set-ups		TRUE	0	Int32
0-2* LCP Display							
0-20	Display Line 1.1 Small	1617	All set-ups		TRUE	-	Uint16
0-21	Display Line 1.2 Small	1614	All set-ups		TRUE	-	Uint16
0-22	Display Line 1.3 Small	1610	All set-ups		TRUE	-	Uint16
0-23	Display Line 2 Large	1613	All set-ups		TRUE	-	Uint16
0-24	Display Line 3 Large	1602	All set-ups		TRUE	-	Uint16
0-25	My Personal Menu	ExpressionLimit	1 set-up		TRUE	0	Uint16
0-4* LCP Keypad							
0-40	[Hand on] Key on LCP	[1] Enabled	All set-ups		TRUE	-	Uint8
0-41	[Off] Key on LCP	[1] Enabled	All set-ups		TRUE	-	Uint8
0-42	[Auto on] Key on LCP	[1] Enabled	All set-ups		TRUE	-	Uint8
0-43	[Reset] Key on LCP	[1] Enabled	All set-ups		TRUE	-	Uint8
0-5* Copy/Save							
0-50	LCP Copy	[0] No copy	All set-ups		FALSE	-	Uint8
0-51	Set-up Copy	[0] No copy	All set-ups		FALSE	-	Uint8
0-6* Password							
0-60	Main Menu Password	100 N/A	1 set-up		TRUE	0	Uint16
0-61	Access to Main Menu w/o Password	[0] Full access	1 set-up		TRUE	-	Uint8
0-65	Quick Menu Password	200 N/A	1 set-up		TRUE	0	Uint16
0-66	Access to Quick Menu w/o Password	[0] Full access	1 set-up		TRUE	-	Uint8

* default setting () display text [] value for use in communication via serial communication port

— How to Programme —

□ 1-** Load/Motor

Par. No. #	Parameter description	Default value	4-set-up	FC 302 series	Change during operation	Conversion index	Type
1-0* General Settings							
1-00	Configuration Mode	null	All set-ups		TRUE	-	Uint8
1-01	Motor Control Principle	null	All set-ups		FALSE	-	Uint8
1-02	Flux Motor Feedback Source	[1] 24V encoder	All set-ups	x	FALSE	-	Uint8
1-03	Torque Characteristics	[0] Constant torque	All set-ups		TRUE	-	Uint8
1-04	Overload Mode	[0] High torque	All set-ups		FALSE	-	Uint8
1-05	Local Mode Configuration	[2] As conf. mode P.1-00	All set-ups		TRUE	-	Uint8
1-1* Motor Selection							
1-10	Motor Construction	[0] Asynchron	All set-ups		FALSE	-	Uint8
1-2* Motor Data							
1-20	Motor Power [kW]	ExpressionLimit	All set-ups		FALSE	1	Uint32
1-21	Motor Power [HP]	ExpressionLimit	All set-ups		FALSE	-2	Uint32
1-22	Motor Voltage	ExpressionLimit	All set-ups		FALSE	0	Uint16
1-23	Motor Frequency	ExpressionLimit	All set-ups		FALSE	0	Uint16
1-24	Motor Current	ExpressionLimit	All set-ups		FALSE	-2	Uint32
1-25	Motor Nominal Speed	ExpressionLimit	All set-ups		FALSE	67	Uint16
1-26	Motor Cont. Rated Torque	ExpressionLimit	All set-ups		FALSE	-1	Uint32
1-29	Automatic Motor Adaptation (AMA)	[0] Off	All set-ups		FALSE	-	Uint8
1-3* Adv. Motor Data							
1-30	Stator Resistance (Rs)	ExpressionLimit	All set-ups		FALSE	-4	Uint32
1-31	Rotor Resistance (Rr)	ExpressionLimit	All set-ups		FALSE	-4	Uint32
1-33	Stator Leakage Reactance (X1)	ExpressionLimit	All set-ups		FALSE	-4	Uint32
1-34	Rotor Leakage Reactance (X2)	ExpressionLimit	All set-ups		FALSE	-4	Uint32
1-35	Main Reactance (Xh)	ExpressionLimit	All set-ups		FALSE	-4	Uint32
1-36	Iron Loss Resistance (Rfe)	ExpressionLimit	All set-ups		FALSE	-3	Uint32
1-37	d-axis Inductance (Ld)	ExpressionLimit	All set-ups	x	FALSE	-4	Int32
1-39	Motor Poles	ExpressionLimit	All set-ups		FALSE	0	Uint8
1-40	Back EMF at 1000 RPM	ExpressionLimit	All set-ups	x	FALSE	0	Uint16
1-41	Motor Angle Offset	0 N/A	All set-ups		FALSE	0	Int16
1-5* Load Indep. Setting							
1-50	Motor Magnetisation at Zero Speed	100 %	All set-ups		TRUE	0	Uint16
1-51	Min Speed Normal Magnetising [RPM]	ExpressionLimit	All set-ups		TRUE	67	Uint16
1-52	Min Speed Normal Magnetising [Hz]	ExpressionLimit	All set-ups		TRUE	-1	Uint16
1-53	Model Shift Frequency	ExpressionLimit	All set-ups	x	FALSE	-1	Uint16
1-55	U/f Characteristic - U	ExpressionLimit	All set-ups		TRUE	-1	Uint16
1-56	U/f Characteristic - F	ExpressionLimit	All set-ups		TRUE	-1	Uint16
1-6* Load Depen. Setting							
1-60	Low Speed Load Compensation	100 %	All set-ups		TRUE	0	Int16
1-61	High Speed Load Compensation	100 %	All set-ups		TRUE	0	Int16
1-62	Slip Compensation	100 %	All set-ups		TRUE	0	Int16
1-63	Slip Compensation Time Constant	0.10 s	All set-ups		TRUE	-2	Uint16
1-64	Resonance Dampening	100 %	All set-ups		TRUE	0	Uint16
1-65	Resonance Dampening Time Constant	5 ms	All set-ups		TRUE	-3	Uint8
1-66	Min. Current at Low Speed	100 %	All set-ups	x	TRUE	0	Uint8
1-67	Load Type	[0] Passive load	All set-ups	x	TRUE	-	Uint8
1-68	Minimum Inertia	ExpressionLimit	All set-ups	x	FALSE	-4	Uint32
1-69	Maximum Inertia	ExpressionLimit	All set-ups	x	FALSE	-4	Uint32
1-7* Start Adjustments							
1-71	Start Delay	0.0 s	All set-ups		TRUE	-1	Uint8
1-72	Start Function	[2] Coast/delay time	All set-ups		TRUE	-	Uint8
1-73	Flying Start	[0] Disabled	All set-ups		FALSE	-	Uint8
1-74	Start Speed [RPM]	ExpressionLimit	All set-ups		TRUE	67	Uint16
1-75	Start Speed [Hz]	ExpressionLimit	All set-ups		TRUE	-1	Uint16
1-76	Start Current	0.00 A	All set-ups		TRUE	-2	Uint32
1-8* Stop Adjustments							
1-80	Function at Stop	[0] Coast	All set-ups		TRUE	-	Uint8
1-81	Min Speed for Function at Stop [RPM]	ExpressionLimit	All set-ups		TRUE	67	Uint16
1-82	Min Speed for Function at Stop [Hz]	ExpressionLimit	All set-ups		TRUE	-1	Uint16
1-83	Precise Stop Function	[0] Precise ramp stop	All set-ups		FALSE	-	Uint8
1-84	Precise Stop Counter Value	100000 N/A	All set-ups		TRUE	0	Uint32
1-85	Precise Stop Speed Comp. Delay	10 ms	All set-ups		TRUE	-3	Uint8
1-9* Motor Temperature							
1-90	Motor Thermal Protection	[0] No protection	All set-ups		TRUE	-	Uint8
1-91	Motor External Fan	[0] No	All set-ups		TRUE	-	Uint16
1-93	Thermistor Resource	[0] None	All set-ups		FALSE	-	Uint8

* default setting () display text [] value for use in communication via serial communication port



— How to Programme —

□ **2-*** Brakes**

Par. No. #	Parameter description	Default value	4-set-up	FC 302 series	Change during operation	Conversion index	Type
2-0* DC-Brake							
2-00	DC Hold Current	50 %	All set-ups		TRUE	0	Uint8
2-01	DC Brake Current	50 %	All set-ups		TRUE	0	Uint16
2-02	DC Braking Time	10.0 s	All set-ups		TRUE	-1	Uint16
2-03	DC Brake Cut In Speed	0 RPM	All set-ups		TRUE	67	Uint16
2-1* Brake Energy Funct.							
2-10	Brake Function	null	All set-ups		TRUE	-	Uint8
2-11	Brake Resistor (ohm)	ExpressionLimit	All set-ups		TRUE	0	Uint16
2-12	Brake Power Limit (kW)	ExpressionLimit	All set-ups		TRUE	0	Uint32
2-13	Brake Power Monitoring	[0] Off	All set-ups		TRUE	-	Uint8
2-15	Brake Check	[0] Off	All set-ups		TRUE	-	Uint8
2-16	AC-brake Max. Current	100.0 %	All set-ups		TRUE	-1	Uint32
2-17	Over-voltage Control	[0] Disabled	All set-ups		TRUE	-	Uint8
2-2* Mechanical Brake							
2-20	Release Brake Current	ExpressionLimit	All set-ups		TRUE	-2	Uint32
2-21	Activate Brake Speed [RPM]	ExpressionLimit	All set-ups		TRUE	67	Uint16
2-22	Activate Brake Speed [Hz]	ExpressionLimit	All set-ups		TRUE	-1	Uint16
2-23	Activate Brake Delay	0.0 s	All set-ups		TRUE	-1	Uint8



* default setting () display text [] value for use in communication via serial communication port

— How to Programme —

□ 3-** Reference / Ramps

Par. No.	Parameter description	Default value	4-set-up	FC 302 series	Change during operation	Conversion index	Type
3-0* Reference Limits							
3-00	Reference Range	null	All set-ups		TRUE	-	Uint8
3-01	Reference/Feedback Unit	null	All set-ups		TRUE	-	Uint8
3-02	Minimum Reference	ExpressionLimit	All set-ups		TRUE	-3	Int32
3-03	Maximum Reference	ExpressionLimit	All set-ups		TRUE	-3	Int32
3-04	Reference Function	[0] Sum	All set-ups		TRUE	-	Uint8
3-1* References							
3-10	Preset Reference	0.00 %	All set-ups		TRUE	-2	Int16
3-11	Jog Speed [Hz]	ExpressionLimit	All set-ups		TRUE	-1	Uint16
3-12	Catch up/slow Down Value	0.00 %	All set-ups		TRUE	-2	Int16
3-13	Reference Site	[0] Linked to Hand / Auto	All set-ups		TRUE	-	Uint8
3-14	Preset Relative Reference	0.00 %	All set-ups		TRUE	-2	Int32
3-15	Reference Resource 1	[1] Analog input 53	All set-ups		TRUE	-	Uint8
3-16	Reference Resource 2	[20] Digital pot.meter	All set-ups		TRUE	-	Uint8
3-17	Reference Resource 3	[11] Local bus reference	All set-ups		TRUE	-	Uint8
3-18	Relative Scaling Reference Resource	[0] No function	All set-ups		TRUE	-	Uint8
3-19	Jog Speed [RPM]	ExpressionLimit	All set-ups		TRUE	67	Uint16
3-4* Ramp 1							
3-40	Ramp 1 Type	[0] Linear	All set-ups		TRUE	-	Uint8
3-41	Ramp 1 Ramp up Time	ExpressionLimit	All set-ups		TRUE	-2	Uint32
3-42	Ramp 1 Ramp Down Time	ExpressionLimit	All set-ups		TRUE	-2	Uint32
3-45	Ramp 1 S-ramp Ratio at Accel. Start	50 %	All set-ups		TRUE	0	Uint8
3-46	Ramp 1 S-ramp Ratio at Accel. End	50 %	All set-ups		TRUE	0	Uint8
3-47	Ramp 1 S-ramp Ratio at Decel. Start	50 %	All set-ups		TRUE	0	Uint8
3-48	Ramp 1 S-ramp Ratio at Decel. End	50 %	All set-ups		TRUE	0	Uint8
3-5* Ramp 2							
3-50	Ramp 2 Type	[0] Linear	All set-ups		TRUE	-	Uint8
3-51	Ramp 2 Ramp up Time	ExpressionLimit	All set-ups		TRUE	-2	Uint32
3-52	Ramp 2 Ramp down Time	ExpressionLimit	All set-ups		TRUE	-2	Uint32
3-55	Ramp 2 S-ramp Ratio at Accel. Start	50 %	All set-ups		TRUE	0	Uint8
3-56	Ramp 2 S-ramp Ratio at Accel. End	50 %	All set-ups		TRUE	0	Uint8
3-57	Ramp 2 S-ramp Ratio at Decel. Start	50 %	All set-ups		TRUE	0	Uint8
3-58	Ramp 2 S-ramp Ratio at Decel. End	50 %	All set-ups		TRUE	0	Uint8
3-6* Ramp 3							
3-60	Ramp 3 Type	[0] Linear	All set-ups		TRUE	-	Uint8
3-61	Ramp 3 Ramp up Time	ExpressionLimit	All set-ups		TRUE	-2	Uint32
3-62	Ramp 3 Ramp down Time	ExpressionLimit	All set-ups		TRUE	-2	Uint32
3-65	Ramp 3 S-ramp Ratio at Accel. Start	50 %	All set-ups		TRUE	0	Uint8
3-66	Ramp 3 S-ramp Ratio at Accel. End	50 %	All set-ups		TRUE	0	Uint8
3-67	Ramp 3 S-ramp Ratio at Decel. Start	50 %	All set-ups		TRUE	0	Uint8
3-68	Ramp 3 S-ramp Ratio at Decel. End	50 %	All set-ups		TRUE	0	Uint8
3-7* Ramp 4							
3-70	Ramp 4 Type	[0] Linear	All set-ups		TRUE	-	Uint8
3-71	Ramp 4 Ramp up Time	ExpressionLimit	All set-ups		TRUE	-2	Uint32
3-72	Ramp 4 Ramp Down Time	ExpressionLimit	All set-ups		TRUE	-2	Uint32
3-75	Ramp 4 S-ramp Ratio at Accel. Start	50 %	All set-ups		TRUE	0	Uint8
3-76	Ramp 4 S-ramp Ratio at Accel. End	50 %	All set-ups		TRUE	0	Uint8
3-77	Ramp 4 S-ramp Ratio at Decel. Start	50 %	All set-ups		TRUE	0	Uint8
3-78	Ramp 4 S-ramp Ratio at Decel. End	50 %	All set-ups		TRUE	0	Uint8
3-8* Other Ramps							
3-80	Jog Ramp Time	ExpressionLimit	All set-ups		TRUE	-2	Uint32
3-81	Quick Stop Ramp Time	ExpressionLimit	2 set-ups		TRUE	-2	Uint32
3-9* Digital Pot.Meter							
3-90	Step Size	0.10 %	All set-ups		TRUE	-2	Uint16
3-91	Ramp Time	1.00 s	All set-ups		TRUE	-2	Uint32
3-92	Power Restore	[0] Off	All set-ups		TRUE	-	Uint8
3-93	Maximum Limit	100 %	All set-ups		TRUE	0	Int16
3-94	Minimum Limit	-100 %	All set-ups		TRUE	0	Int16
3-95	Ramp Delay	1.000 N/A	All set-ups		TRUE	-3	TimD



* default setting () display text [] value for use in communication via serial communication port

— How to Programme —

□ **4-** Limits / Warnings**

Par. No. #	Parameter description	Default value	4-set-up	FC 302 series	Change during operation	Conversion index	Type
4-1* Motor Limits							
4-10	Motor Speed Direction	[0] Clockwise	All set-ups		FALSE	-	Uint8
4-11	Motor Speed Low Limit [RPM]	ExpressionLimit	All set-ups		TRUE	67	Uint16
4-12	Motor Speed Low Limit [Hz]	ExpressionLimit	All set-ups		TRUE	-1	Uint16
4-13	Motor Speed High Limit [RPM]	ExpressionLimit	All set-ups		TRUE	67	Uint16
4-14	Motor Speed High Limit [Hz]	ExpressionLimit	All set-ups		TRUE	-1	Uint16
4-16	Torque Limit Motor Mode	160.0 %	All set-ups		TRUE	-1	Uint16
4-17	Torque Limit Generator Mode	160.0 %	All set-ups		TRUE	-1	Uint16
4-18	Current Limit	ExpressionLimit	All set-ups		TRUE	-1	Uint32
4-19	Max Output Frequency	132.0 Hz	All set-ups		FALSE	-1	Uint16
4-3* Motor Feedb Monitor							
4-30	Motor Feedback Loss Function	[2] Trip	All set-ups		TRUE	-	Uint8
4-31	Motor Feedback Speed Error	300 RPM	All set-ups		TRUE	67	Uint16
4-32	Motor Feedback Loss Timeout	0.05 s	All set-ups		TRUE	-2	Uint16
4-5* Adj. Warnings							
4-50	Warning Current Low	0.00 A	All set-ups		TRUE	-2	Uint32
4-51	Warning Current High	ImaxVLT (P1637)	All set-ups		TRUE	-2	Uint32
4-52	Warning Speed Low	0 RPM	All set-ups		TRUE	67	Uint16
4-53	Warning Speed High	outputSpeedHighLimit (P413)	All set-ups		TRUE	67	Uint16
4-54	Warning Reference Low	-999999.999 N/A	All set-ups		TRUE	-3	Int32
4-55	Warning Reference High	999999.999 N/A	All set-ups		TRUE	-3	Int32
4-56	Warning Feedback Low	ReferenceFeedbackUnit 999999.999 Reference-	All set-ups		TRUE	-3	Int32
4-57	Warning Feedback High	FeedbackUnit	All set-ups		TRUE	-3	Int32
4-58	Missing Motor Phase Function	[1] On	All set-ups		TRUE	-	Uint8
4-6* Speed Bypass							
4-60	Bypass Speed From [RPM]	ExpressionLimit	All set-ups		TRUE	67	Uint16
4-61	Bypass Speed From [Hz]	ExpressionLimit	All set-ups		TRUE	-1	Uint16
4-62	Bypass Speed To [RPM]	ExpressionLimit	All set-ups		TRUE	67	Uint16
4-63	Bypass Speed To [Hz]	ExpressionLimit	All set-ups		TRUE	-1	Uint16



* default setting () display text [] value for use in communication via serial communication port

— How to Programme —

□ **5-** Digital In/Out**

Par. No. #	Parameter description	Default value	4-set-up	FC 302 only	Change during operation	Conversion index	Type
5-0* Digital I/O mode							
5-00	Digital I/O Mode	[0] PNP	All set-ups		FALSE	-	Uint8
5-01	Terminal 27 Mode	[0] Input	All set-ups		TRUE	-	Uint8
5-02	Terminal 29 Mode	[0] Input	All set-ups	x	TRUE	-	Uint8
5-1* Digital Inputs							
5-10	Terminal 18 Digital Input	[8] Start	All set-ups		TRUE	-	Uint8
5-11	Terminal 19 Digital Input	[10] Reversing	All set-ups		TRUE	-	Uint8
5-12	Terminal 27 Digital Input	[2] Coast inverse	All set-ups		TRUE	-	Uint8
5-13	Terminal 29 Digital Input	[14] Joq	All set-ups	x	TRUE	-	Uint8
5-14	Terminal 32 Digital Input	[0] No operation	All set-ups		TRUE	-	Uint8
5-15	Terminal 33 Digital Input	[0] No operation	All set-ups		TRUE	-	Uint8
5-16	Terminal X30/2 Digital Input	[0] No operation	All set-ups		TRUE	-	Uint8
5-17	Terminal X30/3 Digital Input	[0] No operation	All set-ups		TRUE	-	Uint8
5-18	Terminal X30/4 Digital Input	[0] No operation	All set-ups		TRUE	-	Uint8
5-3* Digital Outputs							
5-30	Terminal 27 Digital Output	[0] No operation	All set-ups		TRUE	-	Uint8
5-31	Terminal 29 Digital Output	[0] No operation	All set-ups	x	TRUE	-	Uint8
5-32	Terminal X30/6 Digital Output	[0] No operation	All set-ups		TRUE	-	Uint8
5-33	Terminal X30/7 Digital Output	[0] No operation	All set-ups		TRUE	-	Uint8
5-4* Relays							
5-40	Function Relay	[0] No operation	All set-ups		TRUE	-	Uint8
5-41	On Delay, Relay	0.01 s	All set-ups		TRUE	-2	Uint16
5-42	Off Delay, Relay	0.01 s	All set-ups		TRUE	-2	Uint16
5-5* Pulse Input							
5-50	Term. 29 Low Frequency	100 Hz	All set-ups	x	TRUE	0	Uint32
5-51	Term. 29 High Frequency	100 Hz	All set-ups	x	TRUE	0	Uint32
		0.000 ReferenceFeed-					
5-52	Term. 29 Low Ref./Feedb. Value	backUnit	All set-ups	x	TRUE	-3	Int32
5-53	Term. 29 High Ref./Feedb. Value	ExpressionLimit	All set-ups	x	TRUE	-3	Int32
5-54	Pulse Filter Time Constant #29	100 ms	All set-ups	x	FALSE	-3	Uint16
5-55	Term. 33 Low Frequency	100 Hz	All set-ups		TRUE	0	Uint32
5-56	Term. 33 High Frequency	100 Hz	All set-ups		TRUE	0	Uint32
		0.000 ReferenceFeed-					
5-57	Term. 33 Low Ref./Feedb. Value	backUnit	All set-ups		TRUE	-3	Int32
5-58	Term. 33 High Ref./Feedb. Value	ExpressionLimit	All set-ups		TRUE	-3	Int32
5-59	Pulse Filter Time Constant #33	100 ms	All set-ups		FALSE	-3	Uint16
5-6* Pulse Output							
5-60	Terminal 27 Pulse Output Variable	[0] No operation	All set-ups		TRUE	-	Uint8
5-62	Pulse Output Max Freq #27	5000 Hz	All set-ups		TRUE	0	Uint32
5-63	Terminal 29 Pulse Output Variable	[0] No operation	All set-ups	x	TRUE	-	Uint8
5-65	Pulse Output Max Freq #29	5000 Hz	All set-ups	x	TRUE	0	Uint32
5-66	Terminal X30/6 Pulse Output Variable	[0] No operation	All set-ups		TRUE	-	Uint8
5-68	Pulse Output Max Freq #X30/6	5000 Hz	All set-ups		TRUE	0	Uint32
5-7* 24V Encoder Input							
5-70	Term 32/33 Pulses per Revolution	1024 N/A	All set-ups		FALSE	0	Uint16
5-71	Term 32/33 Encoder Direction	[0] Clockwise	All set-ups		FALSE	-	Uint8
5-72	Term 32/33 Gear Numerator	1 N/A	All set-ups		FALSE	0	Uint16
5-73	Term 32/33 Gear Denominator	1 N/A	All set-ups		FALSE	0	Uint16
5-9* Bus Controlled							
5-90	Digital & Relay Bus Control	0 N/A	All set-ups		TRUE	0	Uint32
5-93	Pulse Out #27 Bus Control	0.00 %	All set-ups		TRUE	-2	N2
5-94	Pulse Out #27 Timeout Preset	0.00 %	1 set-up		TRUE	-2	Uint16
5-95	Pulse Out #29 Bus Control	0.00 %	All set-ups	x	TRUE	-2	N2
5-96	Pulse Out #29 Timeout Preset	0.00 %	1 set-up	x	TRUE	-2	Uint16



* default setting () display text [] value for use in communication via serial communication port

— How to Programme —

□ **6-** Analog In/Out**

Par. No. #	Parameter description	Default value	4-set-up	FC 300 series	Change during operation	Conversion index	Type
6-0* Analog I/O Mode							
6-00	Live Zero Timeout Time	10 s	All set-ups		TRUE	0	Uint8
6-01	Live Zero Timeout Function	[0] Off	All set-ups		TRUE	-	Uint8
6-1* Analog Input 1							
6-10	Terminal 53 Low Voltage	0.07 V	All set-ups		TRUE	-2	Int16
6-11	Terminal 53 High Voltage	10.00 V	All set-ups		TRUE	-2	Int16
6-12	Terminal 53 Low Current	0.14 mA	All set-ups		TRUE	-5	Int16
6-13	Terminal 53 High Current	20.00 mA	All set-ups		TRUE	-5	Int16
		0.000 ReferenceFeed-					
6-14	Terminal 53 Low Ref./Feedb. Value	backUnit	All set-ups		TRUE	-3	Int32
6-15	Terminal 53 High Ref./Feedb. Value	ExpressionLimit	All set-ups		TRUE	-3	Int32
6-16	Terminal 53 Filter Time Constant	0.001 s	All set-ups		TRUE	-3	Uint16
6-2* Analog Input 2							
6-20	Terminal 54 Low Voltage	0.07 V	All set-ups		TRUE	-2	Int16
6-21	Terminal 54 High Voltage	10.00 V	All set-ups		TRUE	-2	Int16
6-22	Terminal 54 Low Current	0.14 mA	All set-ups		TRUE	-5	Int16
6-23	Terminal 54 High Current	20.00 mA	All set-ups		TRUE	-5	Int16
		0.000 ReferenceFeed-					
6-24	Terminal 54 Low Ref./Feedb. Value	backUnit	All set-ups		TRUE	-3	Int32
6-25	Terminal 54 High Ref./Feedb. Value	ExpressionLimit	All set-ups		TRUE	-3	Int32
6-26	Terminal 54 Filter Time Constant	0.001 s	All set-ups		TRUE	-3	Uint16
6-3* Analog Input 3							
6-30	Terminal X30/11 Low Voltage	0.07 V	All set-ups		TRUE	-2	Int16
6-31	Terminal X30/11 High Voltage	10.00 V	All set-ups		TRUE	-2	Int16
		0.000 ReferenceFeed-					
6-34	Term. X30/11 Low Ref./Feedb. Value	backUnit	All set-ups		TRUE	-3	Int32
6-35	Term. X30/11 High Ref./Feedb. Value	ExpressionLimit	All set-ups		TRUE	-3	Int32
6-36	Term. X30/11 Filter Time Constant	0.001 s	All set-ups		TRUE	-3	Uint16
6-4* Analog Input 4							
6-40	Terminal X30/12 Low Voltage	0.07 V	All set-ups		TRUE	-2	Int16
6-41	Terminal X30/12 High Voltage	10.00 V	All set-ups		TRUE	-2	Int16
		0.000 ReferenceFeed-					
6-44	Term. X30/12 Low Ref./Feedb. Value	backUnit	All set-ups		TRUE	-3	Int32
6-45	Term. X30/12 High Ref./Feedb. Value	ExpressionLimit	All set-ups		TRUE	-3	Int32
6-46	Term. X30/12 Filter Time Constant	0.001 s	All set-ups		TRUE	-3	Uint16
6-5* Analog Output 1							
6-50	Terminal 42 Output	[0] No operation	All set-ups		TRUE	-	Uint8
6-51	Terminal 42 Output Min Scale	0.00 %	All set-ups		TRUE	-2	Int16
6-52	Terminal 42 Output Max Scale	100.00 %	All set-ups		TRUE	-2	Int16
6-53	Terminal 42 Output Bus Control	0.00 %	All set-ups		TRUE	-2	N2
6-54	Terminal 42 Output Timeout Preset	0.00 %	1 set-up		TRUE	-2	Uint16
6-6* Analog Output 2							
6-60	Terminal X30/8 Output	[0] No operation	All set-ups		TRUE	-	Uint8
6-61	Terminal X30/8 Min. Scale	0.00 %	All set-ups		TRUE	-2	Int16
6-62	Terminal X30/8 Max. Scale	100.00 %	All set-ups		TRUE	-2	Int16



* default setting () display text [] value for use in communication via serial communication port

— How to Programme —

□ **7-*** Controllers**

Par. No. #	Parameter description	Default value	4-set-up	FC 300 series	Change during operation	Conversion index	Type
7-0* Speed PID Ctrl.							
7-00	Speed PID Feedback Source	null	All set-ups		FALSE	-	Uint8
7-02	Speed PID Proportional Gain	ExpressionLimit	All set-ups		TRUE	-3	Uint16
7-03	Speed PID Integral Time	ExpressionLimit	All set-ups		TRUE	-4	Uint32
7-04	Speed PID Differentiation Time	ExpressionLimit	All set-ups		TRUE	-4	Uint16
7-05	Speed PID Diff. Gain Limit	5.0 N/A	All set-ups		TRUE	-1	Uint16
7-06	Speed PID Lowpass Filter Time	10.0 ms	All set-ups		TRUE	-4	Uint16
7-2* Process Ctrl. Feedb							
7-20	Process CL Feedback 1 Resource	[0] No function	All set-ups		TRUE	-	Uint8
7-22	Process CL Feedback 2 Resource	[0] No function	All set-ups		TRUE	-	Uint8
7-3* Process PID Ctrl.							
7-30	Process PID Normal/ Inverse Control	[0] Normal	All set-ups		TRUE	-	Uint8
7-31	Process PID Anti Windup	[1] On	All set-ups		TRUE	-	Uint8
7-32	Process PID Start Speed	0 RPM	All set-ups		TRUE	67	Uint16
7-33	Process PID Proportional Gain	0.01 N/A	All set-ups		TRUE	-2	Uint16
7-34	Process PID Integral Time	10000.00 s	All set-ups		TRUE	-2	Uint32
7-35	Process PID Differentiation Time	0.00 s	All set-ups		TRUE	-2	Uint16
7-36	Process PID Diff. Gain Limit	5.0 N/A	All set-ups		TRUE	-1	Uint16
7-38	Process PID Feed Forward Factor	0 %	All set-ups		TRUE	0	Uint16
7-39	On Reference Bandwidth	5 %	All set-ups		TRUE	0	Uint8

□ **8-*** Comm. and Options**

Par. No. #	Parameter description	Default value	4-set-up	FC 300 series	Change during operation	Conversion index	Type
8-0* General Settings							
8-01	Control Site	[0] Digital and ctrl.word	All set-ups		TRUE	-	Uint8
8-02	Control Word Source	null	All set-ups		TRUE	-	Uint8
8-03	Control Word Timeout Time	1.0 s	1 set-up		TRUE	-1	Uint32
8-04	Control Word Timeout Function	[0] Off	1 set-up		TRUE	-	Uint8
8-05	End-of-Timeout Function	[1] Resume set-up	1 set-up		TRUE	-	Uint8
8-06	Reset Control Word Timeout	[0] Do not reset	All set-ups		TRUE	-	Uint8
8-07	Diagnosis Trigger	[0] Disable	2 set-ups		TRUE	-	Uint8
8-1* Ctrl. Word Settings							
8-10	Control Word Profile	[0] FC profile	All set-ups		TRUE	-	Uint8
8-13	Configurable Status Word STW	[1] Profile Default	All set-ups		TRUE	-	Uint8
8-3* FC Port Settings							
8-30	Protocol	[0] FC	1 set-up		TRUE	-	Uint8
8-31	Address	1 N/A	1 set-up		TRUE	0	Uint8
8-32	FC Port Baud Rate	[2] 9600 Baud	1 set-up		TRUE	-	Uint8
8-35	Minimum Response Delay	10 ms	All set-ups		TRUE	-3	Uint16
8-36	Max Response Delay	5000 ms	1 set-up		TRUE	-3	Uint16
8-37	Max Inter-Char Delay	25 ms	1 set-up		TRUE	-3	Uint16
8-4* FC MC protocol set							
8-40	Telegram selection	[1] Standard telegram 1	2 set-ups		TRUE	-	Uint8
8-5* Digital/Bus							
8-50	Coasting Select	[3] Logic OR	All set-ups		TRUE	-	Uint8
8-51	Quick Stop Select	[3] Logic OR	All set-ups		TRUE	-	Uint8
8-52	DC Brake Select	[3] Logic OR	All set-ups		TRUE	-	Uint8
8-53	Start Select	[3] Logic OR	All set-ups		TRUE	-	Uint8
8-54	Reversing Select	[3] Logic OR	All set-ups		TRUE	-	Uint8
8-55	Set-up Select	[3] Logic OR	All set-ups		TRUE	-	Uint8
8-56	Preset Reference Select	[3] Logic OR	All set-ups		TRUE	-	Uint8
8-9* Bus Jog							
8-90	Bus Jog 1 Speed	100 RPM	All set-ups		TRUE	67	Uint16
8-91	Bus Jog 2 Speed	200 RPM	All set-ups		TRUE	67	Uint16



* default setting () display text [] value for use in communication via serial communication port

— How to Programme —

□ 9-*** Profibus

Par. No. #	Parameter description	Default value	4-set-up	FC 300 series	Change during operation	Conversion index	Type
9-00	Setpoint	0 N/A	All set-ups		TRUE	0	Uint16
9-07	Actual Value	0 N/A	All set-ups		FALSE	0	Uint16
9-15	PCD Write Configuration	ExpressionLimit	2 set-ups		TRUE	-	Uint16
9-16	PCD Read Configuration	ExpressionLimit	2 set-ups		TRUE	-	Uint16
9-18	Node Address	126 N/A	1 set-up		TRUE	0	Uint8
9-22	Telegram Selection	[108] PPO 8	1 set-up		TRUE	-	Uint8
9-23	Parameters for Signals	0	All set-ups		TRUE	-	Uint16
9-27	Parameter Edit	[1] Enabled	2 set-ups		FALSE	-	Uint16
9-28	Process Control	[1] Enable cyclic master	2 set-ups		FALSE	-	Uint8
9-44	Fault Message Counter	0 N/A	All set-ups		TRUE	0	Uint16
9-45	Fault Code	0 N/A	All set-ups		TRUE	0	Uint16
9-47	Fault Number	0 N/A	All set-ups		TRUE	0	Uint16
9-52	Fault Situation Counter	0 N/A	All set-ups		TRUE	0	Uint16
9-53	Profibus Warning Word	0 N/A	All set-ups		TRUE	0	V2
9-63	Actual Baud Rate	[255] No baudrate found	All set-ups		TRUE	-	Uint8
9-64	Device Identification	0 N/A	All set-ups		TRUE	0	Uint16
							Oct-
9-65	Profile Number	0 N/A	All set-ups		TRUE	0	Str[2]
9-67	Control Word 1	0 N/A	All set-ups		TRUE	0	V2
9-68	Status Word 1	0 N/A	All set-ups		TRUE	0	V2
9-71	Save Data Values	[0] Off	All set-ups		TRUE	-	Uint8
9-72	Drive Reset	[0] No action	1 set-up		FALSE	-	Uint8
9-80	Defined Parameters (1)	0 N/A	All set-ups		FALSE	0	Uint16
9-81	Defined Parameters (2)	0 N/A	All set-ups		FALSE	0	Uint16
9-82	Defined Parameters (3)	0 N/A	All set-ups		FALSE	0	Uint16
9-83	Defined Parameters (4)	0 N/A	All set-ups		FALSE	0	Uint16
9-90	Changed Parameters (1)	0 N/A	All set-ups		FALSE	0	Uint16
9-91	Changed Parameters (2)	0 N/A	All set-ups		FALSE	0	Uint16
9-92	Changed Parameters (3)	0 N/A	All set-ups		FALSE	0	Uint16
9-93	Changed parameters (4)	0 N/A	All set-ups		FALSE	0	Uint16



* default setting () display text [] value for use in communication via serial communication port

— How to Programme —

□ **10-** CAN Fieldbus**

Par. No. #	Parameter description	Default value	4-set-up	FC 300 series	Change during operation	Conversion index	Type
10-0* Common Settings							
10-00	CAN Protocol	null	2 set-ups		FALSE	-	Uint8
10-01	Baud Rate Select	null	2 set-ups		TRUE	-	Uint8
10-02	MAC ID	ExpressionLimit	2 set-ups		TRUE	0	Uint8
10-05	Readout Transmit Error Counter	0 N/A	All set-ups		TRUE	0	Uint8
10-06	Readout Receive Error Counter	0 N/A	All set-ups		TRUE	0	Uint8
10-07	Readout Bus Off Counter	0 N/A	All set-ups		TRUE	0	Uint8
10-1* DeviceNet							
10-10	Process Data Type Selection	null	All set-ups		TRUE	-	Uint8
10-11	Process Data Config Write	ExpressionLimit	2 set-ups		TRUE	-	Uint16
10-12	Process Data Config Read	ExpressionLimit	2 set-ups		TRUE	-	Uint16
10-13	Warning Parameter	0 N/A	All set-ups		TRUE	0	Uint16
10-14	Net Reference	[0] Off	2 set-ups		TRUE	-	Uint8
10-15	Net Control	[0] Off	2 set-ups		TRUE	-	Uint8
10-2* COS Filters							
10-20	COS Filter 1	0 N/A	All set-ups		FALSE	0	Uint16
10-21	COS Filter 2	0 N/A	All set-ups		FALSE	0	Uint16
10-22	COS Filter 3	0 N/A	All set-ups		FALSE	0	Uint16
10-23	COS Filter 4	0 N/A	All set-ups		FALSE	0	Uint16
10-3* Parameter Access							
10-30	Array Index	0 N/A	2 set-ups		TRUE	0	Uint8
10-31	Store Data Values	[0] Off	All set-ups		TRUE	-	Uint8
10-32	Devicenet Revision	ExpressionLimit	All set-ups		TRUE	0	Uint16
10-33	Store Always	[0] Off	1 set-up		TRUE	-	Uint8
10-39	Devicenet F Parameters	0 N/A	All set-ups		TRUE	0	Uint32
10-5* CANopen							
10-50	Process Data Config Write.	ExpressionLimit	2 set-ups		TRUE	-	Uint16
10-51	Process Data Config Read.	ExpressionLimit	2 set-ups		TRUE	-	Uint16



* default setting () display text [] value for use in communication via serial communication port

— How to Programme —

□ **13-** Smart Logic**

Par. No. #	Parameter description	Default value	4-set-up	FC 300 series	Change during operation	Conversion index	Type
13-0* SLC Settings							
13-00	SL Controller Mode	null	2 set-ups		TRUE	-	Uint8
13-01	Start Event	null	2 set-ups		TRUE	-	Uint8
13-02	Stop Event	null	2 set-ups		TRUE	-	Uint8
13-03	Reset SLC	[0] Do not reset SLC	All set-ups		TRUE	-	Uint8
13-1* Comparators							
13-10	Comparator Operand	null	2 set-ups		TRUE	-	Uint8
13-11	Comparator Operator	null	2 set-ups		TRUE	-	Uint8
13-12	Comparator Value	ExpressionLimit	2 set-ups		TRUE	-3	Int32
13-2* Timers							
13-20	SL Controller Timer	ExpressionLimit	1 set-up		TRUE	-3	TimD
13-4* Logic Rules							
13-40	Logic Rule Boolean 1	null	2 set-ups		TRUE	-	Uint8
13-41	Logic Rule Operator 1	null	2 set-ups		TRUE	-	Uint8
13-42	Logic Rule Boolean 2	null	2 set-ups		TRUE	-	Uint8
13-43	Logic Rule Operator 2	null	2 set-ups		TRUE	-	Uint8
13-44	Logic Rule Boolean 3	null	2 set-ups		TRUE	-	Uint8
13-5* States							
13-51	SL Controller Event	null	2 set-ups		TRUE	-	Uint8
13-52	SL Controller Action	null	2 set-ups		TRUE	-	Uint8

□ **14-** Special Functions**

Par. No. #	Parameter description	Default value	4-set-up	FC 302 only	Change during operation	Conversion index	Type
14-0* Inverter Switching							
14-00	Switching Pattern	[1] SFAVM	All set-ups		TRUE	-	Uint8
14-01	Switching Frequency	null	All set-ups		TRUE	-	Uint8
14-03	Overmodulation	[1] On	All set-ups		FALSE	-	Uint8
14-04	PWM Random	[0] Off	All set-ups		TRUE	-	Uint8
14-1* Mains On/Off							
14-12	Function at Mains Imbalance	[0] Trip	All set-ups		TRUE	-	Uint8
14-2* Trip Reset							
14-20	Reset Mode	[0] Manual reset	All set-ups		TRUE	-	Uint8
14-21	Automatic Restart Time	10 s	All set-ups		TRUE	0	Uint16
14-22	Operation Mode	[0] Normal operation	All set-ups		TRUE	-	Uint8
14-25	Trip Delay at Torque Limit	60 s	All set-ups		TRUE	0	Uint8
14-26	Trip Delay at Inverter Fault	ExpressionLimit	All set-ups		TRUE	0	Uint8
14-28	Production Settings	[0] No action	All set-ups		TRUE	-	Uint8
14-29	Service Code	0 N/A	All set-ups		TRUE	0	Int32
14-3* Current Limit Ctrl.							
14-30	Current Lim Cont, Proportional Gain	100 %	All set-ups		FALSE	0	Uint16
14-31	Current Lim Contr, Integration Time	0.020 s	All set-ups		FALSE	-3	Uint16
14-4* Energy Optimising							
14-40	VT Level	66 %	All set-ups		FALSE	0	Uint8
14-41	AEO Minimum Magnetisation	40 %	All set-ups		TRUE	0	Uint8
14-42	Minimum AEO Frequency	10 Hz	All set-ups		TRUE	0	Uint8
14-43	Motor Cosphi	ExpressionLimit	All set-ups		TRUE	-2	Uint16
14-5* Environment							
14-50	RFI Filter	[1] On	1 set-up	x	FALSE	-	Uint8
14-52	Fan Control	[0] Auto	All set-ups		TRUE	-	Uint8

* default setting () display text [] value for use in communication via serial communication port

— How to Programme —

□ **15-** Drive Information**

Par. No. #	Parameter description	Default value	4-set-up	Change during operation	Conversion index	Type
15-0* Operating Data						
15-00	Operating Hours	0 h	All set-ups	FALSE	74	Uin32
15-01	Running Hours	0 h	All set-ups	FALSE	74	Uin32
15-02	kWh Counter	0 kWh	All set-ups	FALSE	75	Uin32
15-03	Power Up's	0 N/A	All set-ups	FALSE	0	Uin32
15-04	Over Temp's	0 N/A	All set-ups	FALSE	0	Uin16
15-05	Over Volt's	0 N/A	All set-ups	FALSE	0	Uin16
15-06	Reset kWh Counter	[0] Do not reset	All set-ups	TRUE	-	Uin8
15-07	Reset Running Hours Counter	[0] Do not reset	All set-ups	TRUE	-	Uin8
15-1* Data Log Settings						
15-10	Logging Source	0	2 set-ups	TRUE	-	Uin16
15-11	Logging Interval	ExpressionLimit	2 set-ups	TRUE	-3	TimD
15-12	Trigger Event	[0] False	1 set-up	TRUE	-	Uin8
15-13	Logging Mode	[0] Log always	2 set-ups	TRUE	-	Uin8
15-14	Samples Before Trigger	50 N/A	2 set-ups	TRUE	0	Uin8
15-2* Historic Log						
15-20	Historic Log: Event	0 N/A	All set-ups	FALSE	0	Uin8
15-21	Historic Log: Value	0 N/A	All set-ups	FALSE	0	Uin32
15-22	Historic Log: Time	0 ms	All set-ups	FALSE	-3	Uin32
15-3* Fault Log						
15-30	Fault Log: Error Code	0 N/A	All set-ups	FALSE	0	Uin8
15-31	Fault Log: Value	0 N/A	All set-ups	FALSE	0	Uin16
15-32	Fault Log: Time	0 s	All set-ups	FALSE	0	Uin32
15-4* Drive Identification						
15-40	FC Type	0 N/A	All set-ups	FALSE	0	VisStr[6]
15-41	Power Section	0 N/A	All set-ups	FALSE	0	VisStr[20]
15-42	Voltage	0 N/A	All set-ups	FALSE	0	VisStr[20]
15-43	Software Version	0 N/A	All set-ups	FALSE	0	VisStr[5]
15-44	Ordered Typecode String	0 N/A	All set-ups	FALSE	0	VisStr[40]
15-45	Actual Typecode String	0 N/A	All set-ups	FALSE	0	VisStr[40]
15-46	Frequency Converter Ordering No	0 N/A	All set-ups	FALSE	0	VisStr[8]
15-47	Power Card Ordering No	0 N/A	All set-ups	FALSE	0	VisStr[8]
15-48	LCP Id No	0 N/A	All set-ups	FALSE	0	VisStr[20]
15-49	SW ID Control Card	0 N/A	All set-ups	FALSE	0	VisStr[20]
15-50	SW ID Power Card	0 N/A	All set-ups	FALSE	0	VisStr[20]
15-51	Frequency Converter Serial Number	0 N/A	All set-ups	FALSE	0	VisStr[10]
15-53	Power Card Serial Number	0 N/A	All set-ups	FALSE	0	VisStr[19]
15-6* Option Ident						
15-60	Option Mounted	0 N/A	All set-ups	FALSE	0	VisStr[30]
15-61	Option SW Version	0 N/A	All set-ups	FALSE	0	VisStr[20]
15-62	Option Ordering No	0 N/A	All set-ups	FALSE	0	VisStr[8]
15-63	Option Serial No	0 N/A	All set-ups	FALSE	0	VisStr[18]
15-70	Option in Slot A	0 N/A	All set-ups	FALSE	0	VisStr[30]
15-71	Slot A Option SW Version	0 N/A	All set-ups	FALSE	0	VisStr[20]
15-72	Option in Slot B	0 N/A	All set-ups	FALSE	0	VisStr[30]
15-73	Slot B Option SW Version	0 N/A	All set-ups	FALSE	0	VisStr[20]
15-74	Option in Slot C0	0 N/A	All set-ups	FALSE	0	VisStr[30]
15-75	Slot C0 Option SW Version	0 N/A	All set-ups	FALSE	0	VisStr[20]
15-76	Option in Slot C1	0 N/A	All set-ups	FALSE	0	VisStr[30]
15-77	Slot C1 Option SW Version	0 N/A	All set-ups	FALSE	0	VisStr[20]
15-9* Parameter Info						
15-92	Defined Parameters	0 N/A	All set-ups	FALSE	0	Uin16
15-93	Modified Parameters	0 N/A	All set-ups	FALSE	0	Uin16
15-99	Parameter Metadata	0 N/A	All set-ups	FALSE	0	Uin16



* default setting () display text [] value for use in communication via serial communication port

— How to Programme —

□ **16-** Data Readouts**

Par. No. #	Parameter description	Default value	4-set-up	FC 302 only	Change during operation	Conversion index	Type
16-0* General Status							
16-00	Control Word	0 N/A	All set-ups		FALSE	0	V2
		0.000 ReferenceFeed-					
16-01	Reference [Unit]	backUnit	All set-ups		FALSE	-3	Int32
16-02	Reference %	0.0 %	All set-ups		FALSE	-1	Int16
16-03	Status Word	0 N/A	All set-ups		FALSE	0	V2
16-05	Main Actual Value [%]	0.00 %	All set-ups		FALSE	-2	N2
16-1* Motor Status							
16-10	Power [kW]	0.00 kW	All set-ups		FALSE	1	Int32
16-11	Power [hp]	0.00 hp	All set-ups		FALSE	-2	Int32
16-12	Motor Voltage	0.0 V	All set-ups		FALSE	-1	Uint16
16-13	Frequency	0.0 Hz	All set-ups		FALSE	-1	Uint16
16-14	Motor Current	0.00 A	All set-ups		FALSE	-2	Int32
16-15	Frequency [%]	0.00 %	All set-ups		FALSE	-2	N2
16-16	Torque	0.0 Nm	All set-ups		FALSE	-1	Int16
16-17	Speed [RPM]	0 RPM	All set-ups		FALSE	67	Int32
16-18	Motor Thermal	0 %	All set-ups		FALSE	0	Uint8
16-20	Motor Angle	0 N/A	All set-ups		TRUE	0	Uint16
16-3* Drive Status							
16-30	DC Link Voltage	0 V	All set-ups		FALSE	0	Uint16
16-32	Brake Energy /s	0.000 kW	All set-ups		FALSE	0	Uint32
16-33	Brake Energy /2 min	0.000 kW	All set-ups		FALSE	0	Uint32
16-34	Heatsink Temp.	0 °C	All set-ups		FALSE	100	Uint8
16-35	Inverter Thermal	0 %	All set-ups		FALSE	0	Uint8
16-36	Inv. Nom. Current	ExpressionLimit	All set-ups		FALSE	-2	Uint32
16-37	Inv. Max. Current	ExpressionLimit	All set-ups		FALSE	-2	Uint32
16-38	SL Controller State	0 N/A	All set-ups		FALSE	0	Uint8
16-39	Control Card Temp.	0 °C	All set-ups		FALSE	100	Uint8
16-40	Logging Buffer Full	[0] No	All set-ups		TRUE	-	Uint8
16-5* Ref. & Feedb.							
16-50	External Reference	0.0 N/A	All set-ups		FALSE	-1	Int16
16-51	Pulse Reference	0.0 N/A	All set-ups		FALSE	-1	Int16
		0.000 ReferenceFeed-					
16-52	Feedback [Unit]	backUnit	All set-ups		FALSE	-3	Int32
16-53	Digi Pot Reference	0.00 N/A	All set-ups		FALSE	-2	Int16
16-6* Inputs & Outputs							
16-60	Digital Input	0 N/A	All set-ups		FALSE	0	Uint16
16-61	Terminal 53 Switch Setting	[0] Current	All set-ups		FALSE	-	Uint8
16-62	Analog Input 53	0.000 N/A	All set-ups		FALSE	-3	Int32
16-63	Terminal 54 Switch Setting	[0] Current	All set-ups		FALSE	-	Uint8
16-64	Analog Input 54	0.000 N/A	All set-ups		FALSE	-3	Int32
16-65	Analog Output 42 [mA]	0.000 N/A	All set-ups		FALSE	-3	Int16
16-66	Digital Output [bin]	0 N/A	All set-ups		FALSE	0	Int16
16-67	Freq. Input #29 [Hz]	0 N/A	All set-ups	x	FALSE	0	Int32
16-68	Freq. Input #33 [Hz]	0 N/A	All set-ups		FALSE	0	Int32
16-69	Pulse Output #27 [Hz]	0 N/A	All set-ups		FALSE	0	Int32
16-70	Pulse Output #29 [Hz]	0 N/A	All set-ups	x	FALSE	0	Int32
16-71	Relay Output [bin]	0 N/A	All set-ups		FALSE	0	Int16
16-72	Counter A	0 N/A	All set-ups		TRUE	0	Int32
16-73	Counter B	0 N/A	All set-ups		TRUE	0	Int32
16-74	Prec. Stop Counter	0 N/A	All set-ups		TRUE	0	Uint32
16-75	Analog In X30/11	0.000 N/A	All set-ups		FALSE	-3	Int32
16-76	Analog In X30/12	0.000 N/A	All set-ups		FALSE	-3	Int32
16-77	Analog Out X30/8 [mA]	0.000 N/A	All set-ups		FALSE	-3	Int16
16-8* Fieldbus & FC Port							
16-80	Fieldbus CTW 1	0 N/A	All set-ups		FALSE	0	V2
16-82	Fieldbus REF 1	0 N/A	All set-ups		FALSE	0	N2
16-84	Comm. Option STW	0 N/A	All set-ups		FALSE	0	V2
16-85	FC Port CTW 1	0 N/A	All set-ups		FALSE	0	V2
16-86	FC Port REF 1	0 N/A	All set-ups		FALSE	0	N2
16-9* Diagnosis Readouts							
16-90	Alarm Word	0 N/A	All set-ups		FALSE	0	Uint32
16-92	Warning Word	0 N/A	All set-ups		FALSE	0	Uint32
16-94	Ext. Status Word	0 N/A	All set-ups		FALSE	0	Uint32

* default setting () display text [] value for use in communication via serial communication port

— How to Programme —

□ **17-** Motor Feedb.Option**

Par. No. #	Parameter description	Default value	4-set-up	Change during operation	Conversion index	Type
17-1* Inc. Enc. Interface						
17-10	Signal Type	[1] RS422 (5V TTL/linedrv.)	All set-ups	FALSE	-	Uint8
17-11	Resolution (PPR)	1024 N/A	All set-ups	FALSE	0	Uint16
17-2* Abs. Enc. Interface						
17-20	Protocol Selection	[0] None	All set-ups	FALSE	-	Uint8
17-21	Resolution (Positions/Rev)	[32768] 32768	All set-ups	FALSE	-	Uint16
17-34	HIPERFACE® Baudrate	[4] 9600	All set-ups	FALSE	-	Uint8
17-6* Monitoring and App.						
17-60	Encoder Positive Direction	[0] Clockwise	All set-ups	FALSE	-	Uint8



* default setting () display text [] value for use in communication via serial communication port

— How to Programme —



* default setting () display text [] value for use in communication via serial communication port

General Specifications



Mains supply (L1, L2, L3):

Supply voltage	200-240 V ±10%
Supply voltage	FC 301: 380-480 V / FC 302: 380-500 V ±10%
Supply voltage	FC 302: 525-600 V ±10%
Supply frequency	50/60 Hz
Max. imbalance between mains phases	± 3.0 % of rated supply voltage
True Power Factor (λ)	≥ 0.9 nominal at rated load
Displacement Power Factor (cos φ) near unity	(> 0.98)
Switching on input supply L1, L2, L3 (power-ups) ≤ 7.5 kW	maximum 2 times/min.
Switching on input supply L1, L2, L3 (power-ups) ≥ 11 kW	maximum 1 time/min.
Environment according to EN60664-1	overvoltage category III/pollution degree 2

The unit is suitable for use on a circuit capable of delivering not more than 100.000 RMS symmetrical Amperes, 240/500/600 V maximum.

Motor output (U, V, W):

Output voltage	0 - 100% of supply voltage
Output frequency	FC 301: 0.2 - 1000 Hz / FC 302: 0 - 1000 Hz
Switching on output	Unlimited
Ramp times	0.01 - 3600 sec.

Torque characteristics:

Starting torque (Constant torque)	maximum 160% for 1 min.*
Starting torque	maximum 180% up to 0.5 sec.*
Overload torque (Constant torque)	maximum 160% for 1 min.*

**Percentage relates to FC 300's nominal current.*

Digital inputs:

Programmable digital inputs	FC 301: 4 (5) / FC 302: 4 (6)
Terminal number	18, 19, 27 ¹⁾ , 29 ⁴⁾ , 32, 33,
Logic	PNP or NPN
Voltage level	0 - 24 V DC
Voltage level, logic '0' PNP	< 5 V DC
Voltage level, logic '1' PNP	> 10 V DC
Voltage level, logic '0' NPN ²⁾	> 19 V DC
Voltage level, logic '1' NPN ²⁾	< 14 V DC



— General Specifications —

Maximum voltage on input 28 V DC
 Input resistance, R_i approx. 4 k Ω

Safe stop Terminal 37⁴⁾:
 Terminal 37 is fixed PNP logic

Voltage level 0 - 24 V DC
 Voltage level, logic'0' PNP < 4 V DC
 Voltage level, logic'1' PNP >20 V DC
 Nominal input current at 24 V 50 mA rms
 Nominal input current at 20 V 60 mA rms
 Input capacitance 400 nF

All digital inputs are galvanically isolated from the supply voltage (PELV) and other high-voltage terminals.

- 1) Terminals 27 and 29 can also be programmed as output.
- 2) Except safe stop input Terminal 37.
- 3) Terminal 37 is only available in FC 302. It can only be used as safe stop input. Terminal 37 is suitable for category 3 installations according to EN 954-1 (safe stop according to category 0 EN 60204-1) as required by the EU Machinery Directive 98/37/EC. Terminal 37 and the Safe Stop function are designed in conformance with EN 60204-1, EN 50178, EN 61800-2, EN 61800-3, and EN 954-1. For correct and safe use of the Safe Stop function follow the related information and instructions in the Design Guide.
- 4) FC 302 only.

Analog inputs:

Number of analog inputs 2
 Terminal number 53, 54
 Modes Voltage or current
 Mode select Switch S201 and switch S202
 Voltage mode Switch S201/switch S202 = OFF (U)
 Voltage level FC 301: 0 to + 10 / FC 302: -10 to +10 V (scaleable)
 Input resistance, R_i approx. 10 k Ω
 Max. voltage \pm 20 V
 Current mode Switch S201/switch S202 = ON (I)
 Current level 0/4 to 20 mA (scaleable)
 Input resistance, R_i approx. 200 Ω
 Max. current 30 mA
 Resolution for analog inputs 10 bit (+ sign)
 Accuracy of analog inputs Max. error 0.5% of full scale
 Bandwidth FC 301: 20 Hz / FC 302: 100 Hz

The analog inputs are galvanically isolated from the supply voltage (PELV) and other high-voltage terminals.

Hz
V
A
IP
°C
Ω

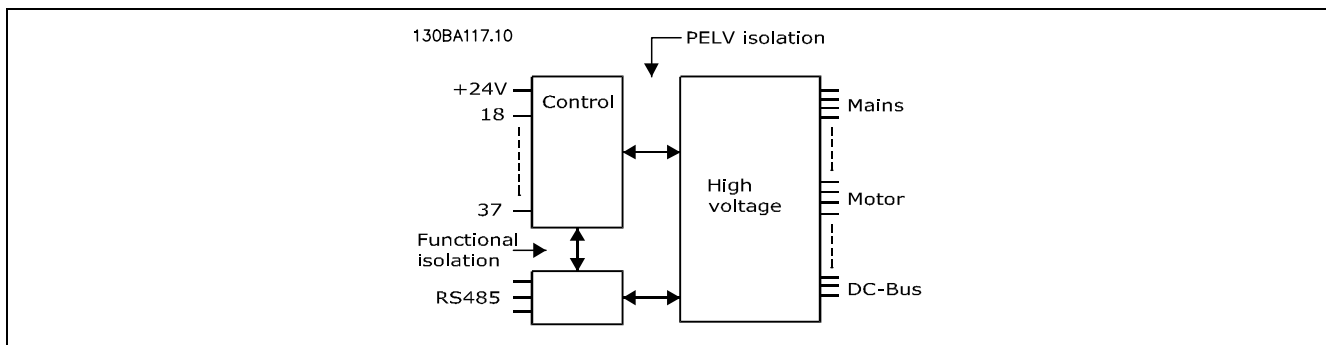

— General Specifications —

Pulse/encoder inputs:

Programmable pulse/encoder inputs	2/1
Terminal number pulse/encoder	29, 33 ¹⁾ / 18, 32, 33 ²⁾
Max. frequency at terminal 18, 29, 32, 33	110 kHz (Push-pull driven)
Max. frequency at terminal 18, 29, 32, 33	5 kHz (open collector)
Min. frequency at terminal 18, 29, 32, 33	4 Hz
Voltage level	see section on Digital input
Maximum voltage on input	28 V DC
Input resistance, R _i	approx. 4 kΩ
Pulse input accuracy (0.1 - 1 kHz)	Max. error: 0.1% of full scale
Encoder input accuracy (1 - 110 kHz)	Max. error: 0.05 % of full scale

The pulse and encoder inputs (terminals 18, 29, 32, 33) are galvanically isolated from the supply voltage (PELV) and other high-voltage terminals.

1) Pulse inputs are 29 and 33
 2) Encoder inputs: 32 = A, and 33 = B

Digital output:

Programmable digital/pulse outputs	2
Terminal number	27, 29 ¹⁾
Voltage level at digital/frequency output	0 - 24 V
Max. output current (sink or source)	40 mA
Max. load at frequency output	1 kΩ
Max. capacitive load at frequency output	10 nF
Minimum output frequency at frequency output	0 Hz
Maximum output frequency at frequency output	32 kHz
Accuracy of frequency output	Max. error: 0.1 % of full scale
Resolution of frequency outputs	12 bit

1) Terminal 27 and 29 can also be programmed as input.

The digital output is galvanically isolated from the supply voltage (PELV) and other high-voltage terminals.

Analog output:

Number of programmable analog outputs	1
Terminal number	42
Current range at analog output	0/4 - 20 mA
Max. load to common at analog output	500 Ω
Accuracy on analog output	Max. error: 0.5 % of full scale
Resolution on analog output	12 bit

The analog output is galvanically isolated from the supply voltage (PELV) and other high-voltage terminals.

Control card, 24 V DC output:

Terminal number	12, 13
Max. load	FC 301: 130 mA / FC 302: 200 mA

The 24 V DC supply is galvanically isolated from the supply voltage (PELV), but has the same potential as the analog and digital inputs and outputs.

Control card, 10 V DC output:

Terminal number	50
Output voltage	10.5 V ±0.5 V
Max. load	15 mA

The 10 V DC supply is galvanically isolated from the supply voltage (PELV) and other high-voltage terminals.



— General Specifications —

Control card, RS 485 serial communication:

Terminal number 68 (P,TX+, RX+), 69 (N,TX-, RX-)
 Terminal number 61 Common for terminals 68 and 69
The RS 485 serial communication circuit is functionally separated from other central circuits and galvanically isolated from the supplier voltage (PELV).

Control card, USB serial communication:

USB standard 1.1 (Full speed)
 USB plug USB type B "device" plug
*Connection to PC is carried out via a standard host/device USB cable.
 The USB connection is galvanically isolated from the supply voltage (PELV) and other high-voltage terminals.
 The USB connection is not galvanically isolated from protection earth. Use only isolated laptop as PC connection to the USB connector on FC 300 drive.*

Relay outputs:

Programmable relay outputs FC 301 ≤ 7.5 kW: 1 / FC 301 ≥ 11 kW: 2 / FC 302 all kW: 2
 Relay 01 Terminal number 1-3 (break), 1-2 (make)
 Max. terminal load (AC-1)¹⁾ on 1-3 (NC), 1-2 (NO) (Resistive load) 240 V AC, 2 A
 Max. terminal load (AC-15)¹⁾ (Inductive load @ cosφ 0.4) 240 V AC, 0.2 A
 Max. terminal load (DC-1)¹⁾ on 1-2 (NO), 1-3 (NC) (Resistive load) 60 V DC, 1A
 Max. terminal load (DC-13)¹⁾ (Inductive load) 24 V DC, 0.1A
 Relay 02 (FC 302 only) Terminal number 4-6 (break), 4-5 (make)
 Max. terminal load (AC-1)¹⁾ on 4-5 (NO) (Resistive load) 400 V AC, 2 A
 Max. terminal load (AC-15)¹⁾ (Inductive load @ cosφ 0.4) 240 V AC, 0.2 A
 Max. terminal load (DC-1)¹⁾ on 4-5 (NC) (Resistive load) 80 V DC, 2 A
 Max. terminal load (DC-13)¹⁾ (Inductive load) 24 V DC, 0.1A
 Max. terminal load (DC-1)¹⁾ on 4-6 (NC) (Resistive load) 50 V DC, 2 A
 Max. terminal load (DC-13)¹⁾ (Inductive load) 24 V DC, 0.1 A
 Min. terminal load on 1-3 (NC), 1-2 (NO), 4-6 (NC), 4-5 (NO) 24 V DC 10 mA, 24 V AC 20 mA
 Environment according to EN 60664-1 overvoltage category III/pollution degree 2
 1) IEC part 4 and 5
The relay contacts are galvanically isolated from the rest of the circuit by reinforced isolation (PELV).

Cable lengths and cross sections:

Max. motor cable length, screened/armoured FC 301: 50 m / FC 302: 150 m
 Max. motor cable length, unscreened/unarmoured FC 301: 75 m / FC 302: 300 m
 Max. cross section to motor, mains, load sharing and brake (see section Electrical Data in the FC 300 Design Guide MG.33.BX.YY for more information), (0.25 kW - 7.5 kW) 4 mm² / 10 AWG
 Max. cross section to motor, mains, load sharing and brake (see section Electrical Data in the FC 300 Design Guide MG.33.BX.YY for more information), (11-15 kW) 16 mm² / 6 AWG
 Max. cross section to motor, mains, load sharing and brake (see section Electrical Data in the FC 300 Design Guide MG.33.BX.YY for more information), (18.5-22 kW) 35 mm² / 2 AWG
 Maximum cross section to control terminals, rigid wire 1.5 mm²/16 AWG (2 x 0.75 mm²)
 Maximum cross section to control terminals, flexible cable 1 mm²/18 AWG
 Maximum cross section to control terminals, cable with enclosed core 0.5 mm²/20 AWG
 Minimum cross section to control terminals 0.25 mm²

Hz V A IP °C

— General Specifications —

Cable lengths and RFI performance			
FC 30x	Filter	Supply voltage	RFI compliance at max. motor cable lengths
FC 301 FC 302	With A2 filter	200 - 240 V / 380 - 480 V / 380 - 500 V	<75 m. EN 55011 Group A2
FC 301	With A1/B	200 - 240 V / 380 - 480 V	<40 m. EN 55011 Group A1 <10 m. EN 55011 Group B
FC 302	With A1/B	200 - 240 V / 380 - 500 V	<150 m. EN 55011 Group A1 <40 m. EN 55011 Group B
FC 302	No RFI filter	550 - 600 V	Not compliant with EN 55011

In certain instances, shorten the motor cable to comply with EN 55011 A1 and EN 55011 B.
Copper (60/75°C) conductors recommended.

Control card performance:

Scan interval FC 301: 5 ms / FC 302: 1 ms

Control characteristics:

Resolution of output frequency at 0 - 1000 Hz FC 301: +/- 0.013 Hz / FC 302: +/- 0.003 Hz
 Repeat accuracy of *Precise start/stop* (terminals 18, 19) FC 301: ≤ ± 1ms / FC 302: ≤ ± 0.1 msec
 System response time (terminals 18, 19, 27, 29, 32, 33) FC 301: ≤ 10 ms / FC 302: ≤ 2 ms
 Speed control range (open loop) 1:100 of synchronous speed
 Speed control range (closed loop) 1:1000 of synchronous speed
 Speed accuracy (open loop) 30 - 4000 rpm: Maximum error of ±8 rpm
 Speed accuracy (closed loop) 0 - 6000 rpm: Maximum error of ±0.15 rpm
All control characteristics are based on a 4-pole asynchronous motor

Surroundings:

Enclosure ≤ 7.5 kW IP 20, IP 55
 Enclosure ≥ 11 kW IP 21, IP 55
 Enclosure kit available ≤ 7.5 kW IP21/TYPE 1/IP 4X top
 Vibration test 1.0 g
 Max. relative humidity 5% - 95%(IEC 721-3-3; Class 3K3 (non-condensing) during operation
 Aggressive environment (IEC 721-3-3), uncoated class 3C2
 Aggressive environment (IEC 721-3-3), coated class 3C3
 Ambient temperature Max. 50 °C (24-hour average maximum 45 °C)
Derating for high ambient temperature, see special conditions in the Design Guide
 Minimum ambient temperature during full-scale operation 0 °C
 Minimum ambient temperature at reduced performance - 10 °C
 Temperature during storage/transport -25 - +65/70 °C
 Maximum altitude above sea level 1000 m
Derating for high altitude, see special conditions in the Design Guide
 EMC standards, Emission EN 61800-3, EN 61000-6-3/4, EN 55011
 EMC standards, Immunity EN 61800-3, EN 61000-6-1/2,
 EN 61000-4-2, EN 61000-4-3, EN 61000-4-4, EN 61000-4-5, EN 61000-4-6
See section on special conditions in the Design Guide



— General Specifications —

Protection and Features:

- Electronic thermal motor protection against overload.
- Temperature monitoring of the heatsink ensures that the frequency converter trips if the temperature reaches $95\text{ °C} \pm 5\text{°C}$. An overload temperature cannot be reset until the temperature of the heatsink is below $70\text{ °C} \pm 5\text{°C}$ (Guideline - these temperatures may vary for different power sizes, enclosures etc.).
- The frequency converter is protected against short-circuits on motor terminals U, V, W.
- If a mains phase is missing, the frequency converter trips or issues a warning (depending on the load).
- Monitoring of the intermediate circuit voltage ensures that the frequency converter trips if the intermediate circuit voltage is too low or too high.
- The frequency converter is protected against earth faults on motor terminals U, V, W.

Troubleshooting



□ Warnings/Alarm Messages

A warning or an alarm icon appears in the display as well as a text string describing the problem. A warning is shown on the display until the fault has been corrected, while an alarm will continue to flash on the LED until you activate the [RESET] key. The table (next page) shows the various warnings and alarms, and whether the fault locks the FC 300. After an *Alarm/Trip locked*, cut off the mains supply and correct the fault. Reconnect mains supply. The FC 300 is now unlocked. The *Alarm/Trip* can be reset manually in three ways:

1. Via the operating key [RESET] on the LCP.
2. Via a digital input.
3. Via serial communication/optional Fieldbus.

You can also choose an automatic reset in par. 14-20 *Reset Mode*. When an X appears in both warning and alarm, it means that either a warning comes before an alarm or that you can define whether a warning or an alarm appears for a given fault. For example, this is possible in par. 1-90 *Motor Thermal Protection*. After an alarm/trip, the motor will remain coasted, and alarm and warning will flash on the FC 300. If the fault disappears, only the alarm will flash.



NB!:

After a manual reset via the [RESET] key on the LCP, it is necessary to push the [AUTO ON] key to restart the motor!



— Troubleshooting —

Alarm/Warning code list				
No.	Description	Warning	Alarm/Trip	Alarm/Trip locked
1	10 Volts low	X		
2	Live zero error	(X)	(X)	
3	No motor	X		
4	Mains phase loss	X	X	X
5	DC link voltage high	X		
6	DC link voltage low	X		
7	DC over voltage	X	X	
8	DC under voltage	X	X	
9	Inverter overloaded	X	X	
10	Motor ETR over temperature	X	X	
11	Motor thermistor over temperature	X	X	
12	Torque limit	X	X	
13	Over Current	X	X	X
14	Earth fault	X	X	X
16	Short Circuit		X	X
17	Control word timeout	(X)	(X)	
25	Brake resistor short-circuited	X		
26	Brake resistor power limit	X	X	
27	Brake chopper fault	X	X	
28	Brake check	X	X	
29	Power card over temp	X	X	X
30	Motor phase U missing		X	X
31	Motor phase V missing		X	X
32	Motor phase W missing		X	X
33	Inrush fault		X	X
34	Fieldbus communication fault	X	X	
38	Internal fault		X	X
47	24 V supply low	X	X	X
48	1.8V supply low		X	X
49	Speed limit	X		
50	AMA calibration failed		X	
51	AMA check Unom and Inom		X	
52	AMA low Inom		X	
53	AMA motor too big		X	
54	AMA motor too small		X	
55	AMA parameter out of range		X	
56	AMA interrupted by user		X	
57	AMA timeout		X	
58	AMA internal fault	X	X	
59	Current limit	X		
61	Encoder loss	(X)	(X)	
62	Output Frequency at Maximum Limit	X		
63	Mechanical Brake Low		X	
64	Voltage Limit	X		
65	Control Card Overtemperature	X	X	X
66	Heatsink Temperature Low	X		
67	Option Configuration has Changed		X	
68	Safe Stop Activated		X	
80	Drive Initialised to Default Value		X	

(X) Dependent on parameter



LED indication	
Warning	yellow
Alarm	flashing red
Trip locked	yellow and red

— Troubleshooting —

Description of Alarm Word, Warning Word and extended Status Word

Alarm Word	Extended Status Word				
Bit	Hex	Dec	AlarmWord	WarningWord	ExtendedStatusWord
0	00000001	1	Brake Check	Brake Check	Ramping
1	00000002	2	Pwr. Card Temp	Pwr. Card Temp	AMA Running
2	00000004	4	Earth Fault	Earth Fault	Start CW/CCW
3	00000008	8	Ctrl.Card Temp	Ctrl.Card Temp	Slow Down
4	00000010	16	Ctrl. Word TO	Ctrl. Word TO	Catch Up
5	00000020	32	Over Current	Over Current	Feedback High
6	00000040	64	Torque Limit	Torque Limit	Feedback Low
7	00000080	128	Motor Th Over	Motor Th Over	Output Current High
8	00000100	256	Motor ETR Over	Motor ETR Over	Output Current Low
9	00000200	512	Inverter Overld.	Inverter Overld.	Output Freq High
10	00000400	1024	DC under Volt	DC under Volt	Output Freq Low
11	00000800	2048	DC over Volt	DC over Volt	Brake Check OK
12	00001000	4096	Short Circuit	DC Voltage Low	Braking Max
13	00002000	8192	Inrush Fault	DC Voltage High	Braking
14	00004000	16384	Mains ph. Loss	Mains ph. Loss	Out of Speed Range
15	00008000	32768	AMA Not OK	No Motor	OVC Active
16	00010000	65536	Live Zero Error	Live Zero Error	
17	00020000	131072	Internal Fault	10V Low	
18	00040000	262144	Brake Overload	Brake Overload	
19	00080000	524288	U phase Loss	Brake Resistor	
20	00100000	1048576	V phase Loss	Brake IGBT	
21	00200000	2097152	W phase Loss	Speed Limit	
22	00400000	4194304	Fieldbus Fault	Fieldbus Fault	
23	00800000	8388608	24 V Supply Low	24V Supply Low	
24	01000000	16777216	Mains Failure	Mains Failure	
25	02000000	33554432	1.8V Supply Low	Current Limit	
26	04000000	67108864	Brake Resistor	Low Temp	
27	08000000	134217728	Brake IGBT	Voltage Limit	
28	10000000	268435456	Option Change	Unused	
29	20000000	536870912	Drive Initialised	Unused	
30	40000000	1073741824	Safe Stop	Unused	
31	80000000	2147483648	Mech. brake low	Warning Word 2	(Extended Status Word)

The alarm words, warning words and extended status words can be read out via serial bus or optional fieldbus for diagnose. See also par. 16-90, 16-92 and 16-94.

WARNING 1**10 Volts low:**

The 10 V voltage from terminal 50 on the control card is below 10 V.
Remove some of the load from terminal 50, as the 10 V supply is overloaded. Max. 15 mA or minimum 590 Ω.

WARNING/ALARM 2**Live zero error:**

The signal on terminal 53 or 54 is less than 50% of the value set in par. 6-10, 6-12, 6-20, or 6-22 respectively.

WARNING/ALARM 3**WARNING/ALARM 3****No motor:**

No motor has been connected to the output of the frequency converter.

WARNING/ALARM 4**Mains phase loss:**

A phase is missing on the supply side, or the mains voltage imbalance is too high.
This message also appears in case of a fault in the input rectifier on the frequency converter.
Check the supply voltage and supply currents to the frequency converter.



— Troubleshooting —

WARNING 5

DC link voltage high:

The intermediate circuit voltage (DC) is higher than the overvoltage limit of the control system. The frequency converter is still active.

WARNING 6

DC link voltage low

The intermediate circuit voltage (DC) is below the undervoltage limit of the control system. The frequency converter is still active.

WARNING/ALARM 7

DC over voltage:

If the intermediate circuit voltage exceeds the limit, the frequency converter trips after a time.

Possible corrections:

- Connect a brake resistor
- Extend the ramp time
- Activate functions in par. 2-10
- Increase par. 14-26

Connect a brake resistor. Extend the ramp time

Alarm/warning limits:			
FC 300 Series	3 x 200 - 240 V [VDC]	3 x 380 - 500 V [VDC]	3 x 525 - 600 V [VDC]
Undervoltage	185	373	532
Voltage warning low	205	410	585
Voltage warning high (w/o brake - w/brake)	390/405	810/840	943/965
Overvoltage	410	855	975

The voltages stated are the intermediate circuit voltage of the FC 300 with a tolerance of ± 5 %. The corresponding mains voltage is the intermediate circuit voltage (DC-link) divided by 1.35

WARNING/ALARM 8

DC under voltage:

If the intermediate circuit voltage (DC) drops below the "voltage warning low" limit (see table above), the frequency converter checks if 24 V backup supply is connected.

If no 24 V backup supply is connected, the frequency converter trips after a given time depending on the unit.

To check whether the supply voltage matches the frequency converter, see *General Specifications*.

WARNING/ALARM 9

Inverter overloaded:

The frequency converter is about to cut out because of an overload (too high current for too long). The counter for electronic, thermal inverter protection gives a warning at 98% and trips at 100%, while giving an alarm. You cannot reset the frequency converter until the counter is below 90%. The fault is that the frequency converter is overloaded by more than 100% for too long.

WARNING/ALARM 10

Motor ETR over temperature:

According to the electronic thermal protection (ETR), the motor is too hot. You can choose if you want the frequency converter to give a warning or an alarm when the counter reaches 100% in par. 1-90. The fault is that the motor is overloaded by more than 100% for too long. Check that the motor par. 1-24 is set correctly.

WARNING/ALARM 11

Motor thermistor over temp:

The thermistor or the thermistor connection is disconnected. You can choose if you want the frequency converter to give a warning or an alarm when the counter reaches 100% in par. 1-90. Check that the thermistor is connected correctly between terminal 53 or 54 (analog voltage input) and terminal 50 (+ 10 Volts supply), or between terminal 18 or 19 (digital input PNP only) and terminal 50. If a KTY sensor is used, check for correct connection between terminal 54 and 55.

WARNING/ALARM 12

Torque limit:

The torque is higher than the value in par. 4-16 (in motor operation) or the torque is higher than the value in par. 4-17 (in regenerative operation).

WARNING/ALARM 13

Over Current:

The inverter peak current limit (approx. 200% of the rated current) is exceeded. The warning will last approx. 8-12 sec., then the frequency converter trips and issues an alarm. Turn off the frequency converter and check if the motor shaft can be turned and if the motor size matches the frequency converter.

If extended mechanical brake control is selected, trip can be reset externally.



— Troubleshooting —

ALARM 14

Earth fault:

There is a discharge from the output phases to earth, either in the cable between the frequency converter and the motor or in the motor itself. Turn off the frequency converter and remove the earth fault.

ALARM 15

In-complete hardware:

A fitted option is not handled by the present control board (hardware or software).

ALARM 16

Short-circuit:

There is short-circuiting in the motor or on the motor terminals. Turn off the frequency converter and remove the short-circuit.

WARNING/ALARM 17

Control word timeout:

There is no communication to the frequency converter. The warning will only be active when par. 8-04 is NOT set to *OFF*. If par. 8-04 is set to *Stop* and *Trip*, a warning appears and the frequency converter ramps down until it trips, while giving an alarm. par. 8-03 *Control word Timeout Time* could possibly be increased.

WARNING 25

Brake resistor short-circuited:

The brake resistor is monitored during operation. If it short-circuits, the brake function is disconnected and the warning appears. The frequency converter still works, but without the brake function. Turn off the frequency converter and replace the brake resistor (see par. 2-15 *Brake Check*).

ALARM/WARNING 26

Brake resistor power limit:

The power transmitted to the brake resistor is calculated as a percentage, as a mean value over the last 120 s, on the basis of the resistance value of the brake resistor (par. 2-11) and the intermediate circuit voltage. The warning is active when the dissipated braking power is higher than 90%. If *Trip* [2] has been selected in par. 2-13, the frequency converter cuts out and issues this alarm, when the dissipated braking power is higher than 100%.

WARNING 27

Brake chopper fault:

The brake transistor is monitored during operation and if it short-circuits, the brake function disconnects

and the warning comes up. The frequency converter is still able to run, but since the brake transistor has short-circuited, substantial power is transmitted to the brake resistor, even if it is inactive. Turn off the frequency converter and remove the brake resistor.

 Warning: There is a risk of substantial power being transmitted to the brake resistor if the brake transistor is short-circuited.

ALARM/WARNING 28

Brake check failed:

Brake resistor fault: the brake resistor is not connected/working.

ALARM 29

Drive over temperature:

If the enclosure is IP 20 or IP 21/TYPE 1, the cut-out temperature of the heat-sink is 95 °C \pm 5 °C. The temperature fault cannot be reset, until the temperature of the heatsink is below 70 °C \pm 5 °C. The fault could be:

- Ambient temperature too high
- Too long motor cable

ALARM 30

Motor phase U missing:

Motor phase U between the frequency converter and the the motor is missing. Turn off the frequency converter and check motor phase U.

ALARM 31

Motor phase V missing:

Motor phase V between the frequency converter and the motor is missing. Turn off the frequency converter and check motor phase V.

ALARM 32

Motor phase W missing:

Motor phase W between the frequency converter and the motor is missing. Turn off the frequency converter and check motor phase W.

ALARM 33

Inrush fault:

Too many powerups have occurred within a short time period. See the chapter *General Specifications* for the allowed number of powerups within one minute.



— Troubleshooting —

WARNING/ALARM 34**Fieldbus communication fault:**

The fieldbus on the communication option card is not working.

WARNING 35**Out of frequency range:**

This warning is active if the output frequency has reached its *Warning speed low* (par. 4-52) or *Warning speed high* (par. 4-53). If the frequency converter is in *Process control, closed loop* (par. 1-00), the warning is active in the display. If the frequency converter is not in this mode bit 008000 *Out of frequency range* in extended status word is active but there is no warning in the display.

ALARM 38**Internal fault:**

Contact your Danfoss supplier.

WARNING 47**24 V supply low:**

The external 24 V DC backup power supply may be overloaded, otherwise Contact your Danfoss supplier.

WARNING 48**1.8 V supply low:**

Contact your Danfoss supplier.

WARNING 49**Speed limit:**

The speed is not within the specified range in par. 4-11 and par. 4-13..

ALARM 50**AMA calibration failed:**

Contact your Danfoss supplier.

ALARM 51**AMA check Unom and Inom:**

The setting of motor voltage, motor current, and motor power is presumably wrong. Check the settings.

ALARM 52**AMA low Inom:**

The motor current is too low. Check the settings.

ALARM 53**AMA motor too big:**

The motor is too big for the AMA to be carried out.

ALARM 54**AMA motor too small:**

The motor is too big for the AMA to be carried out.

ALARM 55**AMA par. out of range:**

The par. values found from the motor are outside acceptable range.

ALARM 56**AMA interrupted by user:**

The AMA has been interrupted by the user.

ALARM 57**AMA timeout:**

Try to start the AMA again a number of times, until the AMA is carried out. Please note that repeated runs may heat the motor to a level where the resistance R_s and R_r are increased. In most cases, however, this is not critical.

ALARM 58**AMA internal fault:**

Contact your Danfoss supplier.

WARNING 59**Current limit:**

Contact your Danfoss supplier.

WARNING 61**Encoder loss:**

Contact your Danfoss supplier.

WARNING 62**Output Frequency at Maximum Limit:**

The output frequency is higher than the value set in par. 4-19

ALARM 63**Mechanical Brake Low:**

The actual motor current has not exceeded the "release brake" current within the "Start delay" time window.

WARNING 64**Voltage Limit:**

The load and speed combination demands a motor voltage higher than the actual DC link voltage.

WARNING/ALARM/TRIP 65**Control Card Over Temperature:**

Control card over temperature: The cut-out temperature of the control card is 80° C.

WARNING 66**Heatsink Temperature Low:**

The heat sink temperature is measured as 0° C. This could indicate that the temperature sensor is defect and thus the fan speed is increased to the maximum in case the power part or control card is very hot.



ALARM 67**Option Configuration has Changed:**

One or more options has either been added or removed since the last power-down.

ALARM 68**Safe Stop Activated:**

Safe Stop has been activated. To resume normal operation, apply 24 V DC to terminal 37, then send a reset signal (via Bus, Digital I/O, or by pressing [RESET]). For correct and safe use of the Safe Stop function follow the related information and instructions in the Design Guide

ALARM 70**Illegal Frequency Configuration:**

Actual combination of control board and power board is illegal.

ALARM 80**Drive Initialised to Default Value:**

Parameter settings are initialised to default setting after a manual (three-finger) reset.





Index

A

Abbreviations	5
Access to Control Terminals	22
Accessory Bag	12
Alarm Messages	69
Alarm/Trip	69
Alarm/Trip locked	69
Analog inputs	64
Analog output	65
Approvals	4
Automatic Motor Adaptation (AMA)	26, 45
Automatic reset	69

B

Basic Enclosures	13
Basic Wiring Example	23
Brake Connection Option	36
Brake control	72

C

Cable lengths and cross sections	66
Cable lengths and RFI performance	67
Coasting	42
Communication option	74
Connection to Mains	15
Control cables	25
Control card performance	67
Control card, +10 V DC output	65
Control card, 24 V DC output	65
Control card, RS 485 serial communication	66
Control card, USB serial communication	66
Control characteristics	67
Control of Mechanical Brake	37
Control Terminals	22
Cooling	14

D

DC link	72
Decoupling plate	17
Default settings	47
DeviceNet	4
Digital inputs:	63
Digital output	65
Display Contrast	43

E

Earth connection	15
Earth leakage current	8
Electrical Installation	22
Electrical Installation, Control Cables	24
ETR	72
External 24 V DC supply	28

F

Fuses	20
-------------	----

G

General warning	9
Graphical display	39

I

Indicator lights	40
Intermediate circuit	32, 72
IP21 / TYPE 1	4

K

KTY sensor	72
------------------	----

L

Local Control Panel	39
Language	45
LC filter	18
LCP	42
LCP 102	39
Leakage Current	9
LEDs	39
Load Sharing	32

M

Mechanical dimensions	14
motor name plate	26
Main Menu mode	41
Main reactance	46
Mains plug connector	15
Mains supply (L1, L2, L3)	63
Maximum Reference	46
MCT 10	4

— Index —

Minimum Reference 46
 Motor Cables..... 19
 Motor Connection 17
 Motor Current 45
 Motor Frequency 45
 Motor Nominal Speed 45
 Motor output..... 63
 Motor overload protection 8
 Motor Power [kW] 45
 Motor protection 68
 Motor Thermal Protection 37
 Motor Voltage..... 45

N

Name plate data26, 26
 Non UL compliance 20

O

Output performance (U, V, W)..... 63

P

Parallel Connection of Motors 37
 Potentiometer Reference 44
 Profibus..... 4
 Protection 20
 Protection and Features 68
 Pulse Start/Stop 44
 Pulse/encoder inputs 65

Q

Quick Menu41, 41
 Quick Menu mode..... 41
 Quick Transfer of Parameter Settings 42

R

Ramp 1 Ramp Down Time..... 46
 Ramp 1 Ramp up Time..... 46
 Relay Connection 36
 Relay outputs..... 66
 Removal of Knockouts for Extra Cables 15
 Repair Work..... 8
 Reset..... 42
 Residual Current Device 9

S

screened/armoured 25

Safe stop 44
 Safety Instructions 8
 Serial communication 66
 Shaft performance level 3
 Side-by-side installation 14
 Speed Up/Down..... 44
 Start/Stop..... 44
 Stator leakage reactance..... 46
 Status..... 40
 Status messages..... 39
 Surroundings 67
 Switches S201, S202, and S801 25
 Symbols 5

T

Tightening Torques 25
 Torque characteristics..... 63

U

Unintended Start..... 8

V

Voltage level 63

W

Warnings 69

2

24 V Back-up Option 28
 24 V DC Backup..... 4