

## Contents

■ <b>How to Read this Design Guide</b> .....	5
□ How to Read this Design Guide .....	5
□ Approvals .....	5
□ Symbols .....	5
□ Abbreviations .....	6
□ Definitions .....	6
□ Power Factor .....	11
■ <b>Introduction to FC 300</b> .....	13
□ Disposal Instruction .....	13
□ Software Version .....	13
□ CE Conformity and Labelling .....	14
□ What Is Covered .....	14
□ Danfoss VLT Frequency Converter and CE Labelling .....	15
□ Compliance with EMC Directive 89/336/EEC .....	15
□ Air Humidity .....	15
□ Aggressive Environments .....	15
□ Vibration and Shock .....	16
□ Control Principle .....	16
□ FC 300 Controls .....	16
□ FC 301 vs. FC 302 Control Principle .....	17
□ Control Structure in VVC <sup>plus</sup> .....	18
□ Control Structure in Flux Sensorless (FC 302 only) .....	19
□ Control Structure in Flux with Motor Feedback .....	20
□ Internal Current Control in VVC+ Mode .....	20
□ Local (Hand On) and Remote (Auto On) Control .....	21
□ Reference Handling .....	24
□ Scaling of References and Feedback .....	25
□ Dead Band Around Zero .....	25
□ Speed PID Control .....	30
□ The following parameters are relevant for the Speed Control .....	30
□ Process PID Control .....	34
□ Ziegler Nichols Tuning Method .....	38
□ General Aspects of EMC Emissions .....	40
□ EMC Test Results (Emission, Immunity) .....	41
□ Required Compliance Levels .....	42
□ EMC Immunity .....	42
□ Galvanic Isolation (PELV) .....	44
□ Earth Leakage Current .....	45
□ Selection of Brake Resistor .....	46
□ Control with Brake Function .....	48
□ Control of Mechanical Brake .....	49
□ Smart Logic Control .....	50
□ Extreme Running Conditions .....	51
□ Motor Thermal Protection .....	51
□ Safe Stop Operation (FC 302 Only) .....	52
■ <b>FC 300 Selection</b> .....	53
□ Electrical Data .....	53
□ General Specifications .....	58
□ Efficiency .....	63

□ Acoustic Noise .....	64
□ Peak Voltage on Motor .....	64
□ Derating for Ambient Temperature - data valid for ≤ 7.5 kW .....	65
□ Derating for Low Air Pressure .....	65
□ Derating for Running at Low Speed .....	65
□ Derating for Installing Long Motor Cables or Cables with Larger Cross-Section .....	66
□ Temperature-Dependent Switch Frequency .....	66
□ Mechanical Dimension .....	67
□ Options and Accessories .....	68
□ Mounting of Option Modules in Slot B .....	68
□ General Purpose Input Output Module MCB 101 .....	68
□ Encoder Option MCB 102 .....	70
□ Resolver Option MCB 103 .....	72
□ Relay Option MCB 105 .....	74
□ 24 V Back-Up Option MCB 107 (Option D) .....	77
□ Brake Resistors .....	78
□ Remote mounting Kit for LCP .....	78
□ IP 21/IP 4X/ TYPE 1 Enclosure Kit .....	78
□ IP 21/Type 1 Enclosure Kit .....	78
□ LC Filters .....	79
■ <b>How to Order</b> .....	81
□ Drive Configurator .....	81
□ Ordering Form Type Code .....	81
□ Ordering Numbers .....	83
■ <b>How to Install</b> .....	89
□ Mechanical Installation .....	89
□ Accessory Bag ≤ 7.5 kW .....	89
□ Safety Requirements of Mechanical Installation .....	91
□ Field Mounting .....	91
□ Electrical Installation .....	92
□ Removal of Knockouts for Extra Cables .....	92
□ Connection to Mains and Earthing .....	92
□ Motor Connection .....	94
□ Motor Cables .....	96
□ Electrical Installation of Motor Cables .....	96
□ Fuses .....	97
□ Access to Control Terminals .....	99
□ Control Terminals (FC 301) .....	99
□ Electrical Installation, Control Terminals .....	100
□ Basic Wiring Example .....	100
□ Electrical Installation, Control Cables .....	101
□ Switches S201, S202, and S801 .....	102
□ Final Set-Up and Test .....	103
□ Safe Stop Installation (FC 302 only) .....	105
□ Safe Stop Commissioning Test .....	106
□ Additional Connections .....	107
□ Load Sharing .....	107
□ Installation of Loadsharing .....	107
□ Brake Connection Option .....	107
□ Relay Connection .....	108
□ Relay Output .....	109
□ Parallel Connection of Motors .....	109

- Direction of Motor Rotation ..... 110
- Motor Thermal Protection ..... 110
- Installation of Brake Cable ..... 110
- RS 485 Bus Connection ..... 110
- How to Connect a PC to the FC 300 ..... 111
- The FC 300 Software Dialog ..... 111
- High Voltage Test ..... 112
- Safety Eart Connection ..... 112
- Electrical Installation - EMC Precautions ..... 112
- Use of EMC-Correct Cables ..... 114
- Earthing of Screened/Armoured Control Cables ..... 115
- Mains Supply Interference/Harmonics ..... 116
- Residual Current Device ..... 116
  
- **Application Examples** ..... 117
  - Start/Stop ..... 117
  - Pulse Start/Stop ..... 117
  - Potentiometer Reference ..... 117
  - Encoder Connection ..... 118
  - Encoder Direction ..... 118
  - Closed Loop Drive System ..... 119
  - Programming of Torque Limit and Stop ..... 120
  - Automatic Motor Adaptation (AMA) ..... 121
  - Smart Logic Control Programming ..... 122
  
- **How to Programme** ..... 125
  - The Graphical and Numerical FC 300 Local ..... 125
  - How to Programme on the Graphical Local Control Panel ..... 125
  - Quick Transfer of Parameter Settings ..... 129
  - Display Mode ..... 130
  - Display Mode - Selection of Read-Outs ..... 130
  - Parameter Set-Up ..... 131
  - Quick Menu Key Functions ..... 131
  - Main Menu Mode ..... 132
  - Parameter Selection ..... 133
  - Changing Data ..... 133
  - Changing a Text Value ..... 133
  - Changing a Group of Numeric Data Values ..... 134
  - Infinitely Variable Change of Numeric Data Value ..... 134
  - Changing of Data Value, Step-by-Step ..... 135
  - Read-out and Programming of Indexed Parameters ..... 135
  - How to Programme on the Numerical Local Control Panel ..... 136
  - Local Control Keys ..... 137
  - Initialisation to Default Settings ..... 139
  - Parameter Selection - FC 300 ..... 140
  - Parameters: Operation and Display ..... 141
  - Parameters: Load and Motor ..... 148
  - Parameters: Brakes ..... 161
  - Parameters: Reference/Ramps ..... 165
  - Parameters: Limits/Warnings ..... 174
  - Parameters: Digital In/Out ..... 179
  - Parameters: Analog In/Out ..... 191
  - Parameters: Controllers ..... 196
  - Parameters: Communications and Options ..... 199

- Parameters: Profibus ..... 204
- Parameters: DeviceNet CAN Fieldbus ..... 210
- Parameters: Smart Logic Control ..... 214
- Parameters: Special Functions ..... 224
- Parameters: Drive Information ..... 228
- Parameters: Data Read-outs ..... 233
- Parameters: EncoderInput ..... 239
- Parameter Lists ..... 241
- Protocols ..... 261
- Telegram Traffic ..... 261
- Telegram Structure ..... 261
- Data Character (byte) ..... 263
- Process Words ..... 268
- Control Word According to FC Profile (CTW) ..... 268
- Status Word According to FC Profile (STW) ..... 271
- Control Word according to PROFIdrive Profile (CTW) ..... 273
- Status Word According to PROFIdrive Profile (STW) ..... 276
- Serial Communication Reference ..... 278
- Present Output Frequency ..... 279
- Example 1: For Controlling the Drive and Reading Parameters ..... 279
- Example 2: Only for Controlling the Drive ..... 280
- Read Parameter Description Elements ..... 280
- Additional Text ..... 285
  
- **Troubleshooting** ..... 287
  - Warnings/Alarm Messages ..... 287
  
- **Index** ..... 295

## How to Read this Design Guide

### □ How to Read this Design Guide

This Design Guide will introduce all aspects of your FC 300.

#### Available literature for FC 300

- The VLT® AutomationDrive FC 300 Operating Instructions MG.33.AX.YY provide the necessary information for getting the drive up and running.
- The VLT® AutomationDrive FC 300 Design Guide MG.33.BX.YY entails all technical information about the drive and customer design and applications.
- The VLT® AutomationDrive FC 300 Profibus Operating Instructions MG.33.CX.YY provide the information required for controlling, monitoring and programming the drive via a Profibus fieldbus.
- The VLT® AutomationDrive FC 300 DeviceNet Operating Instructions MG.33.DX.YY provide the information required for controlling, monitoring and programming the drive via a DeviceNet fieldbus.

X = Revision number

YY = Language code

Danfoss Drives technical literature is also available online at [www.danfoss.com/BusinessAreas/DrivesSolutions/Documentations/Technical+Documentation](http://www.danfoss.com/BusinessAreas/DrivesSolutions/Documentations/Technical+Documentation).

### □ Approvals



### □ Symbols

Symbols used in this Design Guide.



**NB!:**

Indicates something to be noted by the reader.



Indicates a general warning.



Indicates a high-voltage warning.

\* Indicates default setting

□ **Abbreviations**

Alternating current	AC
American wire gauge	AWG
Ampere/AMP	A
Automatic Motor Adaptation	AMA
Current limit	$I_{LIM}$
Degrees Celcius	°C
Direct current	DC
Drive Dependent	D-TYPE
Electro Magnetic Compellability	EMC
Electronic TherMAL Relay	ETR
Frequency Converter	FC
Gram	g
Hertz	Hz
Kilohertz	kHz
Local Control Panel	LCP
Meter	m
Milli Henry Inductance	mH
Milliampere	mA
Millisecond, Second	ms, s
Minute	min
Motion Control Tool	MCT
Motor Type Dependent	M-TYPE
Nanofarad	nF
Newton Meters	Nm
Nominal motor current	$I_{M,N}$
Nominal motor frequency	$f_{M,N}$
Nominal motor power	$P_{M,N}$
Nominal motor voltage	$U_{M,N}$
Parameter	par.
Protective Extra Low Voltage	PELV
Printed Circuit Board	PCB
Rated Inverter Output Current	$I_{INV}$
Revolutions Per Minute	RPM
Second	s
Torque limit	$T_{LIM}$
Volts	V

□ **Definitions**

**Drive:**

D-TYPE

Size and type of the connected drive (dependencies).

$I_{VLT,MAX}$

The maximum output current.

$I_{VLT,N}$

The rated output current supplied by the frequency converter.

$U_{VLT, MAX}$

The maximum output voltage.

— How to Read this Design Guide —

**Input:**Control command

You can start and stop the connected motor by means of LCP and the digital inputs. Functions are divided into two groups.

Functions in group 1 have higher priority than functions in group 2.

Group 1	Reset, Coasting stop, Reset and Coasting stop, Quick-stop, DC braking, Stop and the "Off" key.
Group 2	Start, Pulse start, Reversing, Start reversing, Jog and Freeze output

**Motor:** $f_{JOG}$ 

The motor frequency when the jog function is activated (via digital terminals).

 $f_M$ 

The motor frequency.

 $f_{MAX}$ 

The maximum motor frequency.

 $f_{MIN}$ 

The minimum motor frequency.

 $f_{M,N}$ 

The rated motor frequency (nameplate data).

 $I_M$ 

The motor current.

 $I_{M,N}$ 

The rated motor current (nameplate data).

M-TYPE

Size and type of the connected motor (dependencies).

 $n_{M,N}$ 

The rated motor speed (nameplate data).

 $P_{M,N}$ 

The rated motor power (nameplate data).

 $T_{M,N}$ 

The rated torque (motor).

 $U_M$ 

The instantaneous motor voltage.

 $U_{M,N}$ 

The rated motor voltage (nameplate data).

— How to Read this Design Guide —

Break-away torque

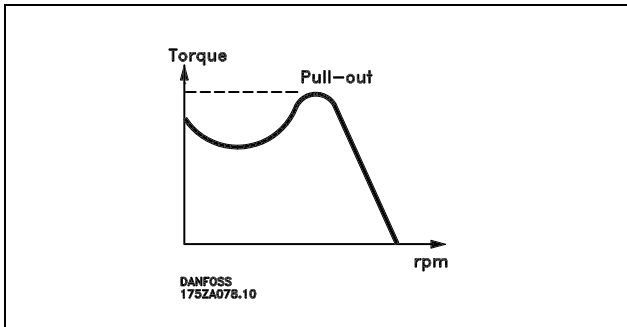

$\eta_{VLT}$

The efficiency of the frequency converter is defined as the ratio between the power output and the power input.

Start-disable command

A stop command belonging to the group 1 control commands - see this group.

Stop command

See Control commands.

**References:**

Analog Reference

A signal transmitted to the analog inputs 53 or 54, can be voltage or current.

Binary Reference

A signal transmitted to the serial communication port.

Preset Reference

A defined preset reference to be set from -100% to +100% of the reference range. Selection of eight preset references via the digital terminals.

Pulse Reference

A pulse frequency signal transmitted to the digital inputs (terminal 29 or 33).

Ref<sub>MAX</sub>

Determines the relationship between the reference input at 100% full scale value (typically 10 V, 20mA) and the resulting reference. The maximum reference value set in par. 3-03.

Ref<sub>MIN</sub>

Determines the relationship between the reference input at 0% value (typically 0V, 0mA, 4mA) and the resulting reference. The minimum reference value set in par. 3-02.

**Miscellaneous:**

Analog Inputs

The analog inputs are used for controlling various functions of the frequency converter.

There are two types of analog inputs:

Current input, 0-20 mA and 4-20 mA

Voltage input, 0-10 V DC (FC 301)

Voltage input, -10 - +10 V DC (FC 302).

Analog Outputs

The analog outputs can supply a signal of 0-20 mA, 4-20 mA, or a digital signal.



## — How to Read this Design Guide —

### Automatic Motor Adaptation, AMA

AMA algorithm determines the electrical parameters for the connected motor at standstill.

### Brake Resistor

The brake resistor is a module capable of absorbing the brake power generated in regenerative braking. This regenerative braking power increases the intermediate circuit voltage and a brake chopper ensures that the power is transmitted to the brake resistor.

### CT Characteristics

Constant torque characteristics used for all applications such as conveyor belts, displacement pumps and cranes.

### Digital Inputs

The digital inputs can be used for controlling various functions of the frequency converter.

### Digital Outputs

The drive features two Solid State outputs that can supply a 24 V DC (max. 40 mA) signal.

### DSP

Digital Signal Processor.

### **Relay Outputs:**

The FC 301 drive features one programmable Relay Output.

The FC 302 drive features two programmable Relay Outputs.

### ETR

Electronic Thermal Relay is a thermal load calculation based on present load and time. Its purpose is to estimate the motor temperature.

### Hiperface®

Hiperface® is a registered trademark by Stegmann.

### Initialising

If initialising is carried out (par. 14-22), the frequency converter returns to the default setting.

### Intermittent Duty Cycle

An intermittent duty rating refers to a sequence of duty cycles. Each cycle consists of an on-load and an off-load period. The operation can be either periodic duty or none-periodic duty.

### LCP

The Local Control Panel (LCP) makes up a complete interface for control and programming of the FC 300 Series. The control panel is detachable and can be installed up to 3 metres from the frequency converter, i.e. in a front panel by means of the installation kit option.

### lsb

Least significant bit.

### MCM

Short for Mille Circular Mil, an American measuring unit for cable cross-section.  $1 \text{ MCM} \equiv 0.5067 \text{ mm}^2$ .

### msb

Most significant bit.

### On-line/Off-line Parameters

Changes to on-line parameters are activated immediately after the data value is changed. Changes to off-line parameters are not activated until you enter [OK] on the LCP.

### Process PID

The PID regulator maintains the desired speed, pressure, temperature, etc. by adjusting the output frequency to match the varying load.

## — How to Read this Design Guide —

### Pulse Input/Incremental Encoder

An external, digital pulse transmitter used for feeding back information on motor speed. The encoder is used in applications where great accuracy in speed control is required.

### RCD

Residual Current Device.

### Set-up

You can save parameter settings in four Set-ups. Change between the four parameter Set-ups and edit one Set-up, while another Set-up is active.

### SFAVM

Switching pattern called S tator F lux oriented A synchronous V ector M odulation (par. 14-00).

### Slip Compensation

The frequency converter compensates for the motor slip by giving the frequency a supplement that follows the measured motor load keeping the motor speed almost constant..

### Smart Logic Control (SLC)

The SLC is a sequence of user defined actions executed when the associated user defined events are evaluated as true by the SLC.

### Thermistor:

A temperature-dependent resistor placed where the temperature is to be monitored (frequency converter or motor).

### Trip

A state entered in fault situations, e.g. if the frequency converter is subject to an over-temperature or when the frequency converter is protecting the motor, process or mechanism. Restart is prevented until the cause of the fault has disappeared and the trip state is cancelled by activating reset or, in some cases, by being programmed to reset automatically. Trip may not be used for personal safety.

### Trip Locked

A state entered in fault situations when the frequency converter is protecting itself and requiring physical intervention, e.g. if the frequency converter is subject to a short circuit on the output. A locked trip can only be cancelled by cutting off mains, removing the cause of the fault, and reconnecting the frequency converter. Restart is prevented until the trip state is cancelled by activating reset or, in some cases, by being programmed to reset automatically. Trip may not be used for personal safety.

### VT Characteristics

Variable torque characteristics used for pumps and fans.

### VVC<sup>plus</sup>

If compared with standard voltage/frequency ratio control, Voltage Vector Control (VVC<sup>plus</sup>) improves the dynamics and the stability, both when the speed reference is changed and in relation to the load torque.

### 60° AVM

Switching pattern called 60° A synchronous V ector M odulation (par. 14-00).

— How to Read this Design Guide —

□ **Power Factor**

The power factor is the relation between  $I_1$  and  $I_{RMS}$ .

$$\text{Power factor} = \frac{\sqrt{3} \times U \times I_1 \times \cos \varphi}{\sqrt{3} \times U \times I_{RMS}}$$

The power factor for 3-phase control:

$$= \frac{I_1 \times \cos \varphi_1}{I_{RMS}} = \frac{I_1}{I_{RMS}} \text{ since } \cos \varphi_1 = 1$$

The power factor indicates to which extent the frequency converter imposes a load on the mains supply.

$$I_{RMS} = \sqrt{I_1^2 + I_5^2 + I_7^2 + \dots + I_n^2}$$

The lower the power factor, the higher the  $I_{RMS}$  for the same kW performance.

In addition, a high power factor indicates that the different harmonic currents are low. The FC 300 frequency converters' built-in DC coils produce a high power factor, which minimises the imposed load on the mains supply.

— How to Read this Design Guide —

## Introduction to FC 300

### □ Disposal Instruction



Equipment containing electrical components may not be disposed together with domestic waste. It must be separate collected with Electrical and Electronic waste according to local and currently valid legislation.



### Caution

The FC 300 AutomationDrive DC link capacitors remain charged after power has been disconnected. To avoid an electrical shock hazard, disconnect the FC 300 from the mains before carrying out maintenance. Wait at least as follows before doing service on the frequency converter:

FC 300: 0.25 – 7.5 kW 4 minutes

FC 300: 11 – 22 kW 15 minutes

Be aware that there may be high voltage on the DC link even when the LEDs are turned off.

**FC 300**  
**Design Guide**  
**Software version: 3.5x**



This Design Guide can be used for all FC 300 frequency converters with software version 3.5x. The software version number can be seen from parameter 15-43.

## □ CE Conformity and Labelling

### What is CE Conformity and Labelling?

The purpose of CE labelling is to avoid technical trade obstacles within EFTA and the EU. The EU has introduced the CE label as a simple way of showing whether a product complies with the relevant EU directives. The CE label says nothing about the specifications or quality of the product. Frequency converters are regulated by three EU directives:

#### The machinery directive (98/37/EEC)

All machines with critical moving parts are covered by the machinery directive of January 1, 1995. Since a frequency converter is largely electrical, it does not fall under the machinery directive. However, if a frequency converter is supplied for use in a machine, we provide information on safety aspects relating to the frequency converter. We do this by means of a manufacturer's declaration.

#### The low-voltage directive (73/23/EEC)

Frequency converters must be CE labelled in accordance with the low-voltage directive of January 1, 1997. The directive applies to all electrical equipment and appliances used in the 50 - 1000 V AC and the 75 - 1500 V DC voltage ranges. Danfoss CE-labels in accordance with the directive and issues a declaration of conformity upon request.

#### The EMC directive (89/336/EEC)

EMC is short for electromagnetic compatibility. The presence of electromagnetic compatibility means that the mutual interference between different components/appliances does not affect the way the appliances work. The EMC directive came into effect January 1, 1996. Danfoss CE-labels in accordance with the directive and issues a declaration of conformity upon request. To carry out EMC-correct installation, see the instructions in this Design Guide. In addition, we specify which standards our products comply with. We offer the filters presented in the specifications and provide other types of assistance to ensure the optimum EMC result.

The frequency converter is most often used by professionals of the trade as a complex component forming part of a larger appliance, system or installation. It must be noted that the responsibility for the final EMC properties of the appliance, system or installation rests with the installer.

## □ What Is Covered

The EU "Guidelines on the Application of Council Directive 89/336/EEC" outline three typical situations of using a frequency converter. See below for EMC coverage and CE labelling.

1. The frequency converter is sold directly to the end-consumer. The frequency converter is for example sold to a DIY market. The end-consumer is a layman. He installs the frequency converter himself for use with a hobby machine, a kitchen appliance, etc. For such applications, the frequency converter must be CE labelled in accordance with the EMC directive.
2. The frequency converter is sold for installation in a plant. The plant is built up by professionals of the trade. It could be a production plant or a heating/ventilation plant designed and installed by professionals of the trade. Neither the frequency converter nor the finished plant has to be CE labelled under the EMC directive. However, the unit must comply with the basic EMC requirements of the directive. This is ensured by using components, appliances, and systems that are CE labelled under the EMC directive.
3. The frequency converter is sold as part of a complete system. The system is being marketed as complete and could e.g. be an air-conditioning system. The complete system must be CE labelled in accordance with the EMC directive. The manufacturer can ensure CE labelling under the EMC directive either by using CE labelled components or by testing the EMC of the system. If he chooses to use only CE labelled components, he does not have to test the entire system.

## — Introduction to FC 300 —

**□ Danfoss VLT Frequency Converter and CE Labelling**

CE labelling is a positive feature when used for its original purpose, i.e. to facilitate trade within the EU and EFTA.

However, CE labelling may cover many different specifications. Thus, you have to check what a given CE label specifically covers.

The covered specifications can be very different and a CE label may therefore give the installer a false feeling of security when using a frequency converter as a component in a system or an appliance.

Danfoss CE labels the frequency converters in accordance with the low-voltage directive. This means that if the frequency converter is installed correctly, we guarantee compliance with the low-voltage directive. Danfoss issues a declaration of conformity that confirms our CE labelling in accordance with the low-voltage directive.

The CE label also applies to the EMC directive provided that the instructions for EMC-correct installation and filtering are followed. On this basis, a declaration of conformity in accordance with the EMC directive is issued.

The Design Guide offers detailed instructions for installation to ensure EMC-correct installation. Furthermore, Danfoss specifies which our different products comply with.

Danfoss gladly provides other types of assistance that can help you obtain the best EMC result.

**□ Compliance with EMC Directive 89/336/EEC**

As mentioned, the frequency converter is mostly used by professionals of the trade as a complex component forming part of a larger appliance, system, or installation. It must be noted that the responsibility for the final EMC properties of the appliance, system or installation rests with the installer. As an aid to the installer, Danfoss has prepared EMC installation guidelines for the Power Drive System. The standards and test levels stated for Power Drive Systems are complied with, provided that the EMC-correct instructions for installation are followed, see section *Electrical Installation*.

**□ Air Humidity**

The frequency converter has been designed to meet the IEC/EN 60068-2-3 standard, EN 50178 pkt. 9.4.2.2 at 50°C.

**□ Aggressive Environments**

A frequency converter contains a large number of mechanical and electronic components. All are to some extent vulnerable to environmental effects.

 The frequency converter should not be installed in environments with airborne liquids, particles, or gases capable of affecting and damaging the electronic components. Failure to take the necessary protective measures increases the risk of stoppages, thus reducing the life of the frequency converter.

Liquids can be carried through the air and condense in the frequency converter and may cause corrosion of components and metal parts. Steam, oil, and salt water may cause corrosion of components and metal parts. In such environments, use equipment with enclosure rating IP 55. As an extra protection, coated printed circuit boards can be ordered as an option.

Airborne Particles such as dust may cause mechanical, electrical, or thermal failure in the frequency converter. A typical indicator of excessive levels of airborne particles is dust particles around the frequency converter fan. In very dusty environments, use equipment with enclosure rating IP 55 or a cabinet for IP 00/IP 20/TYPE 1 equipment.

## — Introduction to FC 300 —

In environments with high temperatures and humidity, corrosive gases such as sulphur, nitrogen, and chlorine compounds will cause chemical processes on the frequency converter components.

Such chemical reactions will rapidly affect and damage the electronic components. In such environments, mount the equipment in a cabinet with fresh air ventilation, keeping aggressive gases away from the frequency converter.

An extra protection in such areas is a coating of the printed circuit boards, which can be ordered as an option.



### **NB!:**

Mounting frequency converters in aggressive environments increases the risk of stoppages and considerably reduces the life of the converter.

Before installing the frequency converter, check the ambient air for liquids, particles, and gases. This is done by observing existing installations in this environment. Typical indicators of harmful airborne liquids are water or oil on metal parts, or corrosion of metal parts.

Excessive dust particle levels are often found on installation cabinets and existing electrical installations. One indicator of aggressive airborne gases is blackening of copper rails and cable ends on existing installations.

### □ **Vibration and Shock**

The frequency converter has been tested according to a procedure based on the shown standards:

The frequency converter complies with requirements that exist for units mounted on the walls and floors of production premises, as well as in panels bolted to walls or floors.

IEC/EN 60068-2-6:	Vibration (sinusoidal) - 1970
IEC/EN 60068-2-64:	Vibration, broad-band random

### □ **Control Principle**

A frequency converter rectifies AC voltage from mains into DC voltage, after which this DC voltage is converted into a AC current with a variable amplitude and frequency.

The motor is supplied with variable voltage / current and frequency, which enables infinitely variable speed control of three-phased, standard AC motors and permanent magnet synchronous motors.

### □ **FC 300 Controls**

The frequency converter is capable of controlling either the speed or the torque on the motor shaft. Setting par. 1-00 determines the type of control.

#### Speed control:

There are two types of speed control:

- Speed open loop control which does not require any feedback (sensorless).
- Speed closed loop control in the form of a PID control that requires a speed feedback to an input. A properly optimised speed closed loop control will have higher accuracy than a speed open loop control.

Selects which input to use as speed PID feedback in par. 7-00.

#### Torque control (FC 302 only):

Torque control is part of the motor control and correct settings of motor parameters are very important. The accuracy and settling time of the torque control are determined from *Flux with motor feedback* (par. 1-01 *Motor Control Principle*).

- Flux sensorless offers superior performance in all four quadrants at motor frequencies above 10 Hz.
- Flux with encoder feedback offers superior performance in all four quadrants and at all motor speeds.



— Introduction to FC 300 —

Speed / torque reference:

The reference to these controls can either be a single reference or be the sum of various references including relatively scaled references. The handling of references is explained in detail later in this section.

□ **FC 301 vs. FC 302 Control Principle**

FC 301 is a general purpose frequency converter for variable speed applications. The control principle is based on Voltage Vector Control (VVC<sup>plus</sup>).

FC 301 can handle asynchronous motors only.

The current sensing principle in FC 301 is based on current measurement in the DC link or motor phase. The ground fault protection on the motor side is solved by a de-saturation circuit in the IGBTs connected to the control board.

Short circuit behaviour on FC 301 depends on the current transducer in the positive DC link and the desaturation protection with feedback from the 3 lower IGBT's and the brake.

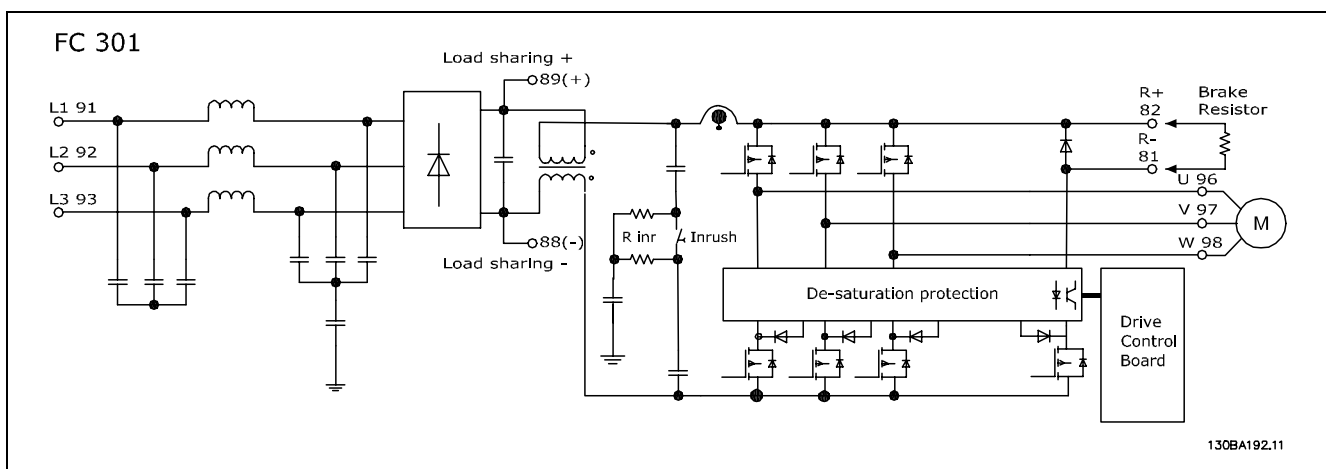

FC 302 is a high performance frequency converter for demanding applications. The frequency converter can handle various kinds of motor control principles such as U/f special motor mode, VVC<sup>plus</sup> or Flux Vector motor control.

FC 302 is able to handle Permanent Magnet Synchronous Motors (Brushless servo motors) as well as normal squirrel cage asynchronous motors.

Short circuit behaviour on FC 302 depends on the 3 current transducers in the motor phases and the desaturation protection with feedback from the brake.

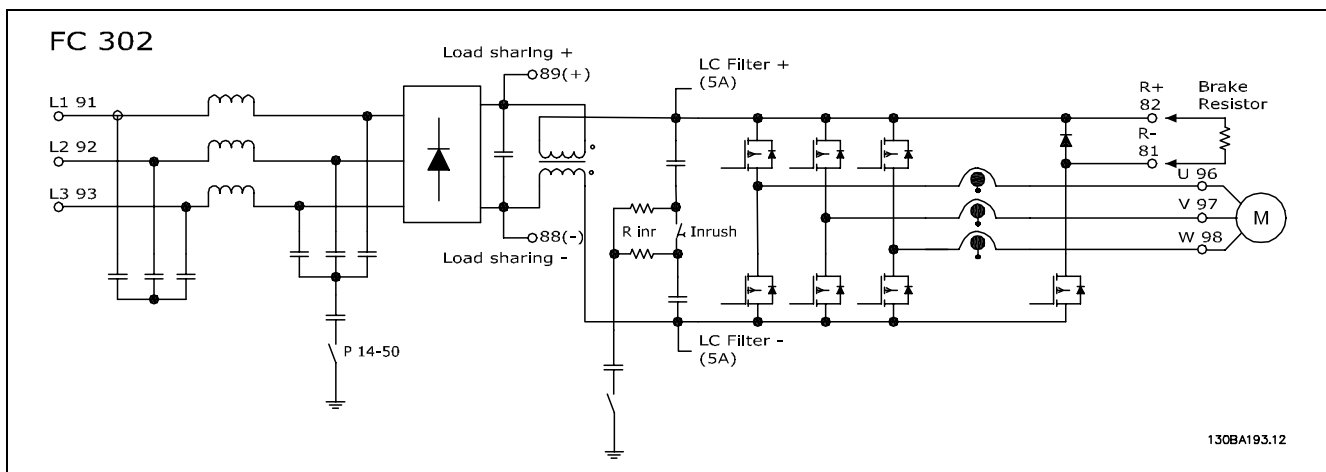

— Introduction to FC 300 —

□ **Control Structure in VVC<sup>plus</sup>**

Control structure in VVC<sup>plus</sup> open loop and closed loop configurations:

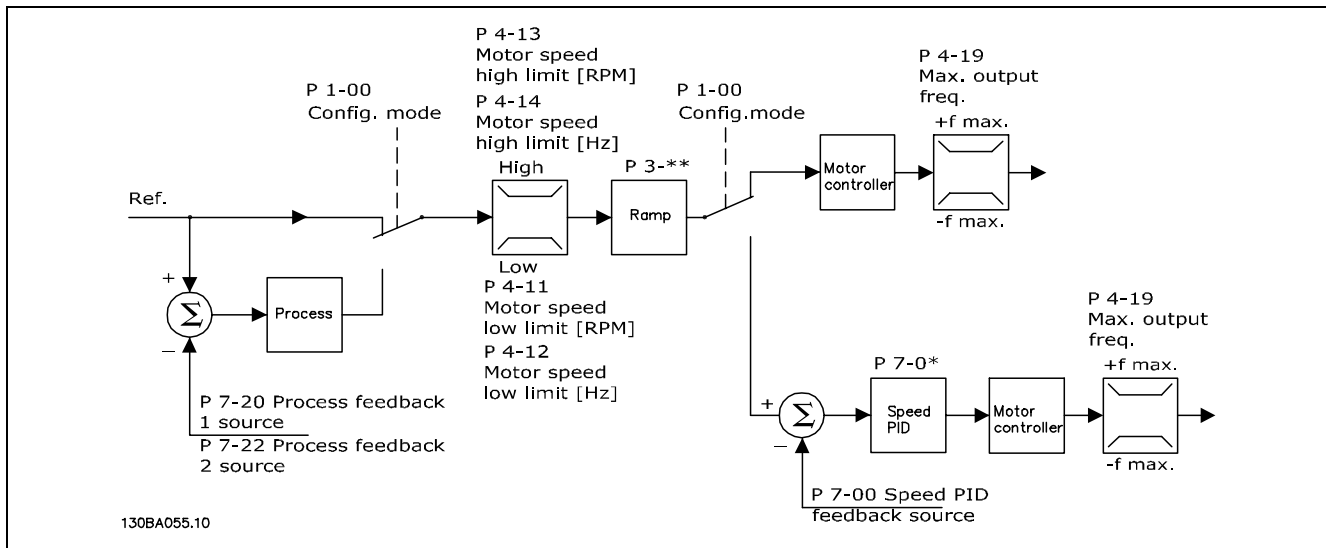

In the configuration shown in the illustration above, par. 1-01 *Motor Control Principle* is set to “VVC<sup>plus</sup> [1]” and par. 1-00 is set to “Speed open loop [0]”. The resulting reference from the reference handling system is received and fed through the ramp limitation and speed limitation before being sent to the motor control. The output of the motor control is then limited by the maximum frequency limit.

If par. 1-00 is set to “Speed closed loop [1]” the resulting reference will be passed from the ramp limitation and speed limitation into a speed PID control. The Speed PID control parameters are located in the par. group 7-0\*. The resulting reference from the Speed PID control is sent to the motor control limited by the frequency limit.

Select “Process [3]” in par. 1-00 to use the process PID control for closed loop control of e.g. speed or pressure in the controlled application. The Process PID parameters are located in par. group 7-2\* and 7-3\*.

□ **Control Structure in Flux Sensorless (FC 302 only)**

Control structure in Flux sensorless open loop and closed loop configurations.

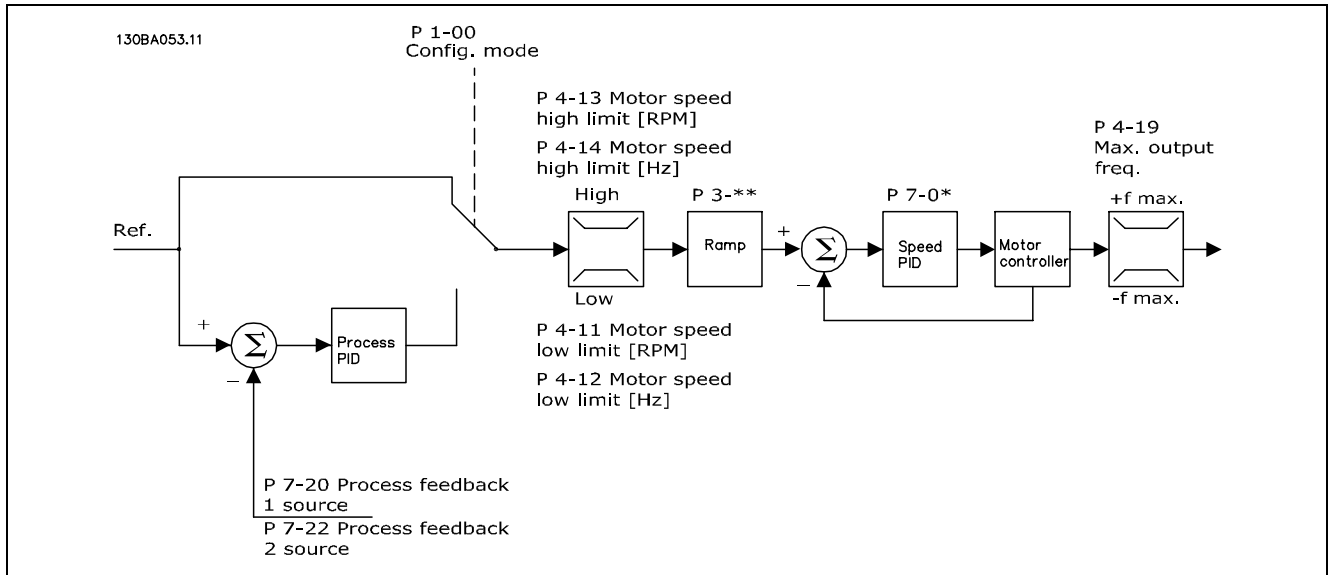

In the shown configuration, par. 1-01 *Motor Control Principle* is set to “Flux sensorless [2]” and par. 1-00 is set to “Speed open loop [0]”. The resulting reference from the reference handling system is fed through the ramp and speed limitations as determined by the parameter settings indicated.

An estimated speed feedback is generated to the Speed PID to control the output frequency. The Speed PID must be set with its P,I, and D parameters (par. group 7-0\*).

Select “Process [3]” in par. 1-00 to use the process PID control for closed loop control of i.e. speed or pressure in the controlled application. The Process PID parameters are found in par. group 7-2\* and 7-3\*.

— Introduction to FC 300 —

□ **Control Structure in Flux with Motor Feedback**

Control structure in Flux with motor feedback configuration (only available in FC 302):

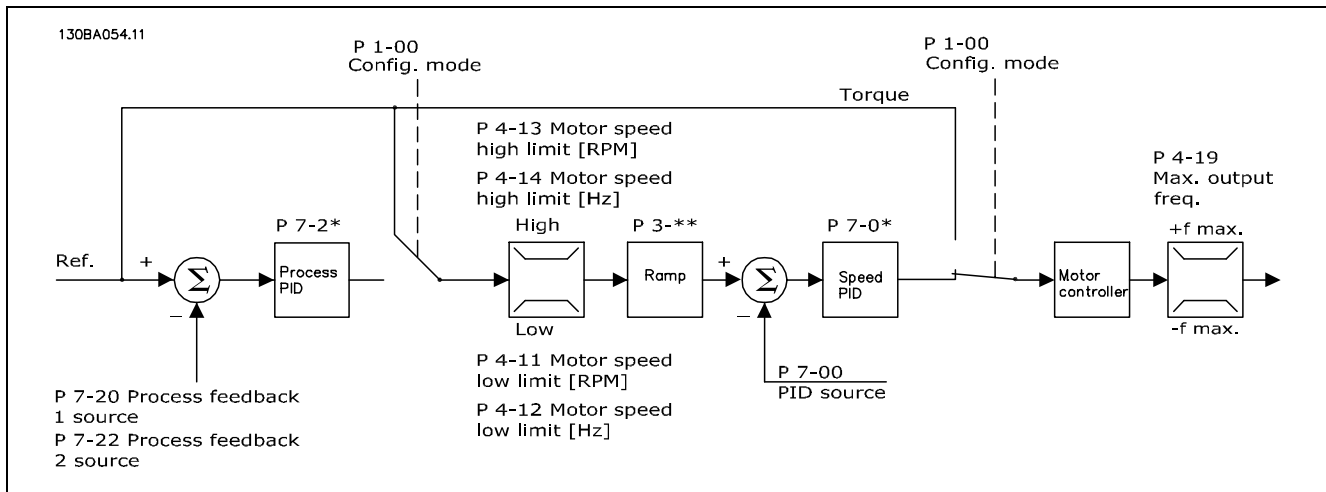

In the shown configuration, par. 1-01 *Motor Control Principle* is set to “Flux w motor feedb [3]” and par. 1-00 is set to “Speed closed loop [1]”.

The motor control in this configuration relies on a feedback signal from an encoder mounted directly on the motor (set in par. 1-02 *Motor Shaft Encoder Source*).

Select “Speed closed loop [1]” in par. 1-00 to use the resulting reference as an input for the Speed PID control. The Speed PID control parameters are located in par. group 7-0\*.

Select “Torque [2]” in par. 1-00 to use the resulting reference directly as a torque reference. Torque control can only be selected in the *Flux with motor feedback* (par. 1-01 *Motor Control Principle*) configuration. When this mode has been selected, the reference will use the Nm unit. It requires no torque feedback, since the actual torque is calculated on the basis of the current measurement of the frequency converter.

Select “Process [3]” in par. 1-00 to use the process PID control for closed loop control of e.g. speed or a process variable in the controlled application.

□ **Internal Current Control in VVC+ Mode**

The frequency converter features an integral current limit control which is activated when the motor current, and thus the torque, is higher than the torque limits set in par. 4-16, 4-17 and 4-18. When the frequency converter is at the current limit during motor operation or regenerative operation, the frequency converter will try to get below the preset torque limits as quickly as possible without losing control of the motor.

— Introduction to FC 300 —

□ **Local (Hand On) and Remote (Auto On) Control**

The frequency converter can be operated manually via the local control panel (LCP) or remotely via analog and digital inputs and serial bus.

If allowed in par. 0-40, 0-41, 0-42, and 0-43, it is possible to start and stop the frequency converter via the LCP using the [Hand ON] and [Off] keys. Alarms can be reset via the [RESET] key. After pressing the [Hand On] key, the frequency converter goes into Hand mode and follows (as default) the Local reference that can be set using arrow key on the LCP.

After pressing the [Auto On] key, the frequency converter goes into Auto mode and follows (as default) the Remote reference. In this mode, it is possible to control the frequency converter via the digital inputs and various serial interfaces (RS-485, USB, or an optional fieldbus). See more about starting, stopping, changing ramps and parameter set-ups etc. in par. group 5-1\* (digital inputs) or par. group 8-5\* (serial communication).

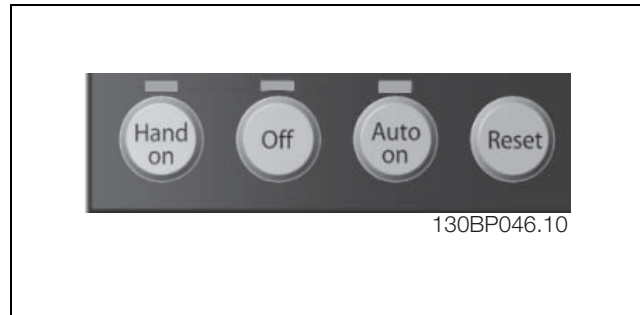

**Active Reference and Configuration Mode**

The active reference can be either the local reference or the remote reference.

In par. 3-13 *Reference Site* the local reference can be permanently selected by selecting *Local* [2]. To permanently select the remote reference select *Remote* [1]. By selecting *Linked to Hand/Auto* [0] (default) the reference site will depend on which mode is active. (Hand Mode or Auto Mode).

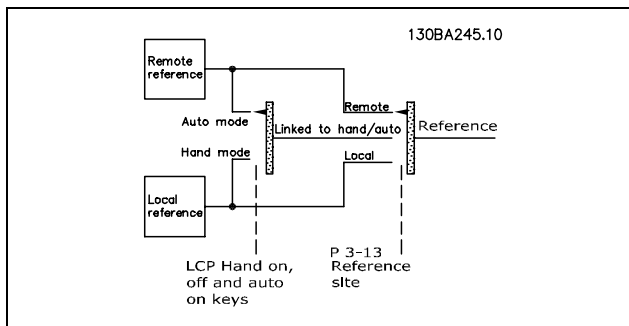

Hand Off Auto LCP Keys	Reference Site Par. 3-13	Active Reference
Hand	Linked to Hand / Auto	Local
Hand -> Off	Linked to Hand / Auto	Local
Auto	Linked to Hand / Auto	Remote
Auto -> Off	Linked to Hand / Auto	Remote
All keys	Local	Local
All keys	Remote	Remote

The table shows under which conditions either the Local reference or the Remote reference is active. One of them is always active, but both can not be active at the same time.

— Introduction to FC 300 —

Par. 1-00 *Configuration Mode* determines what kind of application control principle (i.e. Speed, Torque or Process Control) is used when the Remote reference is active (see table above for the conditions).

Par. 1-05 *Local Mode Configuration* determines the kind of application control principle that is used when the Local reference is made activate.

**Reference Handling**

**Local Reference**

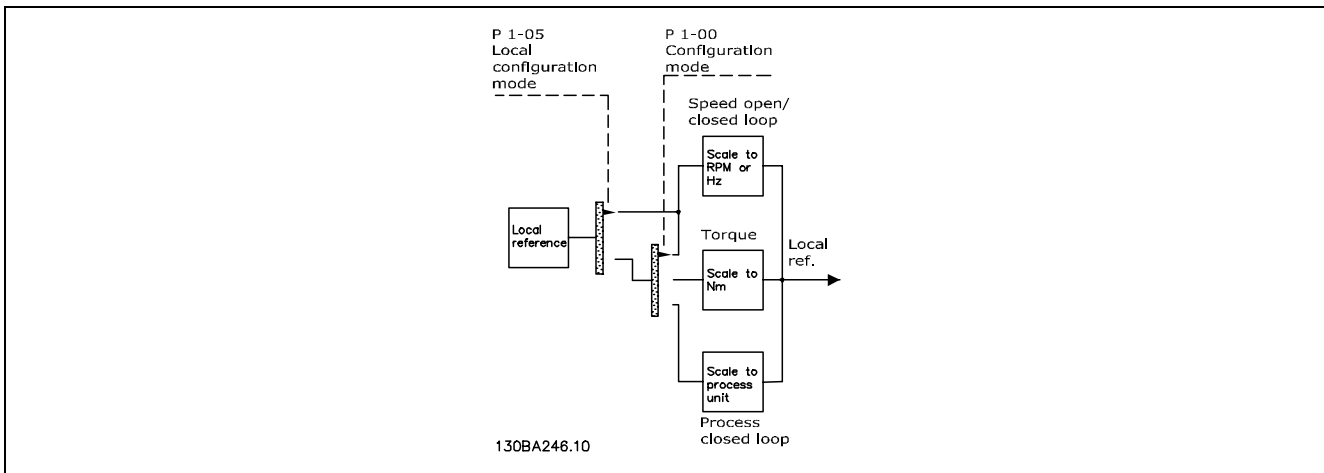

**Remote Reference**

The reference handling system for calculating the Remote reference is shown in the illustration below.

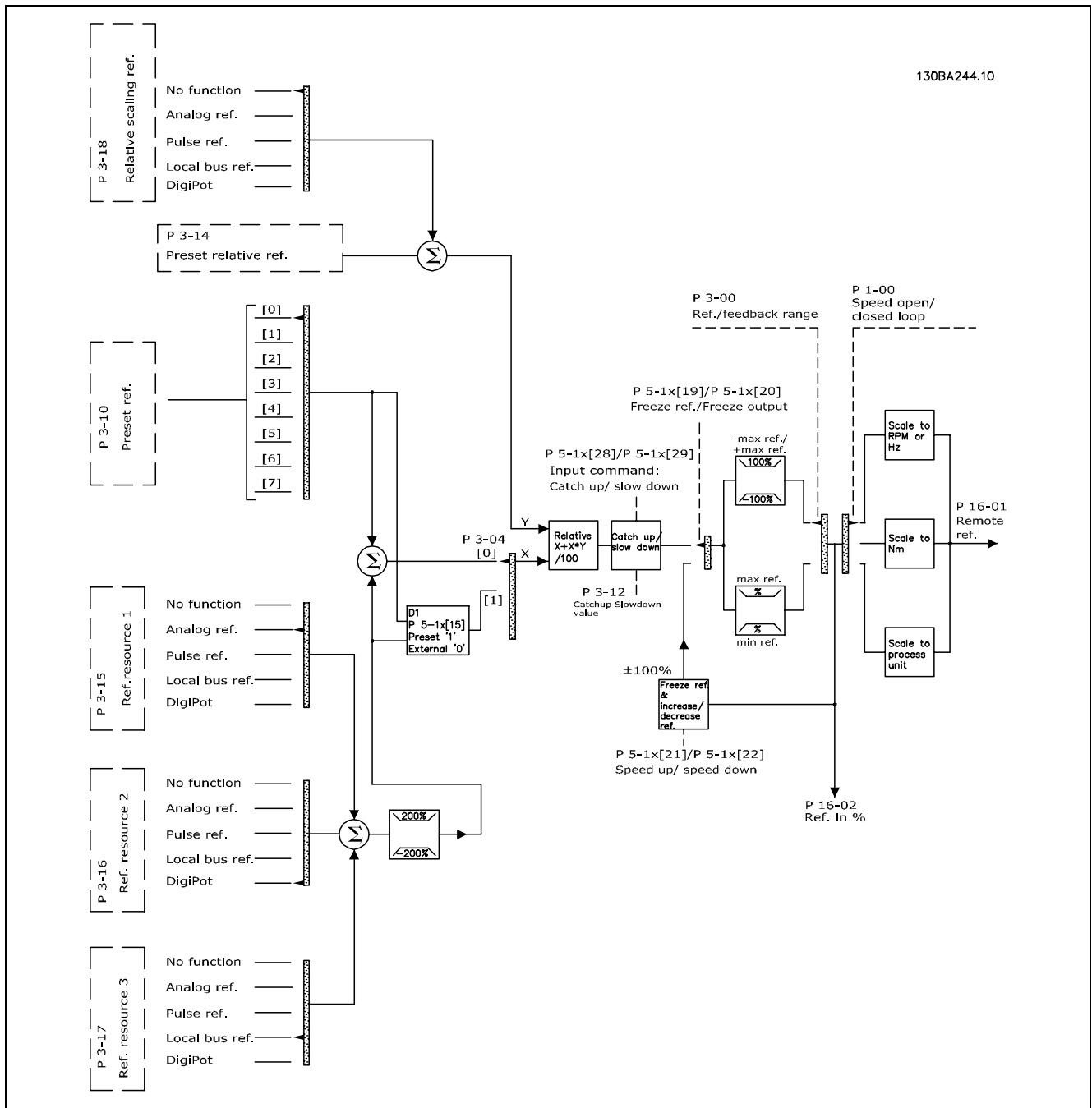

— Introduction to FC 300 —

The Remote reference is calculated once every scan interval and initially consists of two parts:

1. X (the external reference) : A sum (see par. 3-04) of up to four externally selected references, comprising any combination (determined by the setting of par. 3-15, 3-16 and 3-17) of a fixed preset reference (par. 3-10), variable analog references, variable digital pulse references, and various serial bus references in whatever unit frequency converter are controlled ([Hz], [RPM], [Nm] etc.).
2. Y- (the relative reference): A sum of one fixed preset reference (par. 3-14) and one variable analog reference (par. 3-18) in [%].

The two parts are combined in the following calculation: Remote reference =  $X + X * Y / 100\%$ .  
 The *catch up / slow down* function and the *freeze reference* function can both be activated by digital inputs on the frequency converter. They are described in par. group 5-1\*.  
 The scaling of analog references are described in par. groups 6-1\* and 6-2\*, and the scaling of digital pulse references are described in par. group 5-5\*.  
 Reference limits and ranges are set in par. group 3-0\*.

References and feedback can be scaled in physical units (i.e. RPM, Hz, °C) or simply in % relating to the values of par. 3-02 *Minimum Reference* and par. 3-03 *Maximum Reference*.

In that case all analog and pulse inputs are scaled according to the following rules:

- When par. 3-00 *Reference Range* is [0] Min - Max 0% reference equals 0 [unit] where unit can be any unit e.g. rpm, m/s, bar etc. 100% reference equals the Max (abs (par. 3-03 *Maximum Reference*), abs (par. 3-02 *Minimum Reference*)).
- When par. 3-00 *Reference Range*: [1] -Max - +Max 0% reference equals 0 [unit] -100% reference equals -Max Reference 100% reference equals Max Reference.

Bus references are scaled according to the following rules:

- When par. 3-00 *Reference Range* is [0] Min - Max. To obtain max resolution on the bus reference the scaling on the bus is: 0% reference equals Min Reference and 100% reference equals Max reference.
- When par. 3-00 *Reference Range*: [1] -Max - +Max -100% reference equals -Max Reference 100% reference equals Max Reference.

Par. 3-00 *Reference Range*, 3-02 *Minimum Reference* and 3-03 *Maximum Reference* together define the allowed range of the sum of all references. The sum of all references are clamped when necessary. The relation between the resulting reference (after clamping) and the sum of all references is shown below.

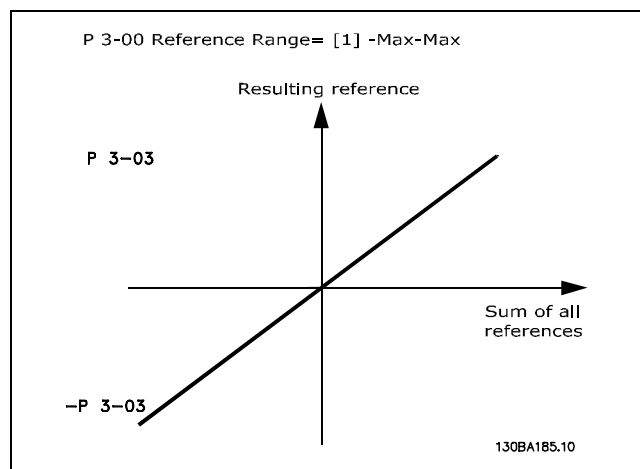
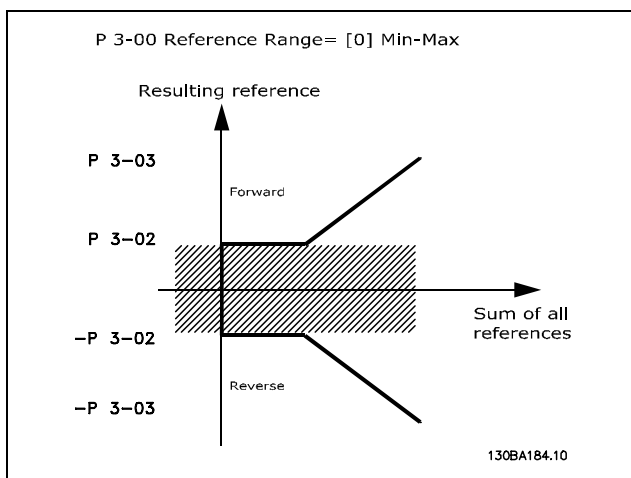



— Introduction to FC 300 —

The value of par. 3-02 *Minimum Reference* can not be set to less than 0, unless the par. 1-00 *Configuration Mode* is set to [3] *Process*. In that case the following relations between the resulting reference (after clamping) and the sum of all references is as shown to the right.

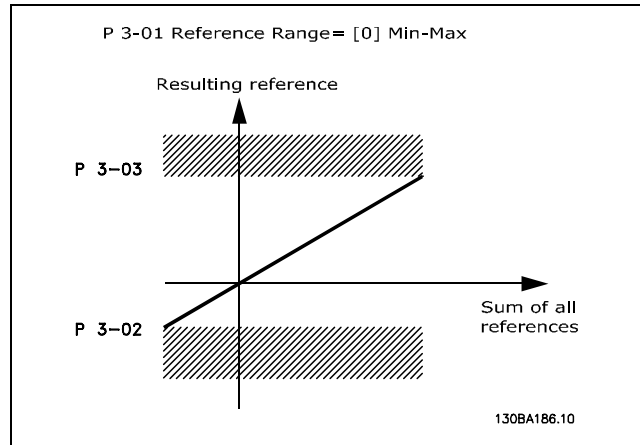

References and feedback are scaled from analog and pulse inputs in the same way. The only difference is that a reference above or below the specified minimum and maximum "endpoints" (P1 and P2 in the graph below) are clamped whereas a feedback above or below is not.

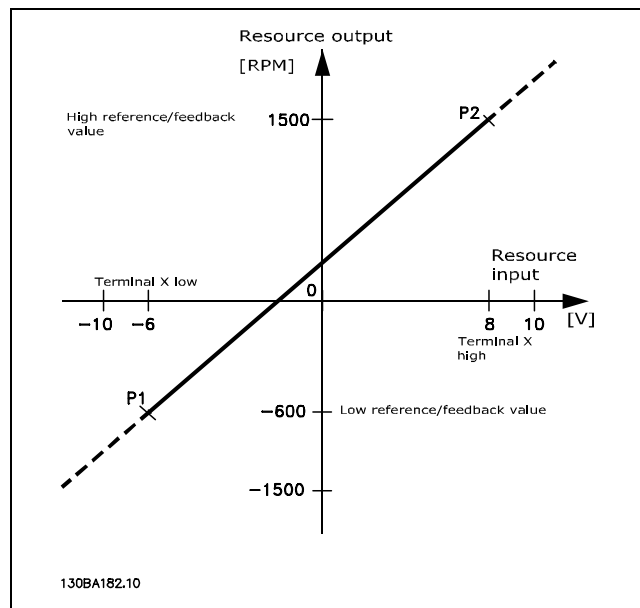
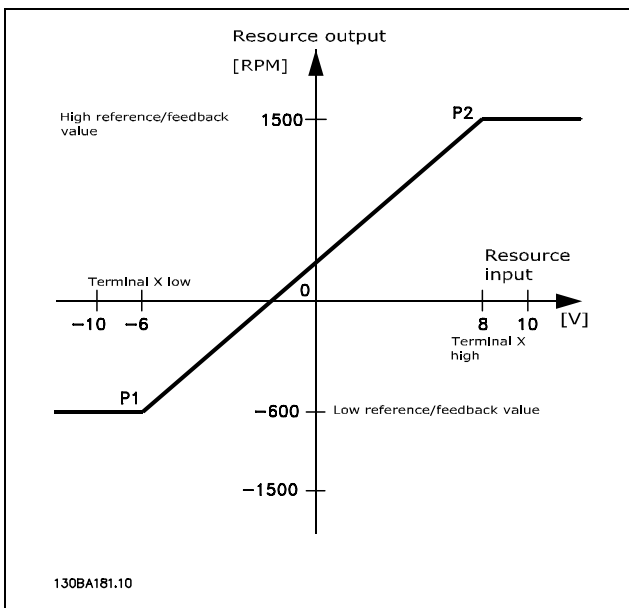

The endpoints P1 and P2 are defined by the following parameters depending on which analog or pulse input is used

	Analog 53 S201=OFF	Analog 53 S201=ON	Analog 54 S202=OFF	Analog 54 S202=ON	Pulse Input 29	Pulse Input 33
<b>P1 = (Minimum input value, Minimum reference value)</b>						
Minimum reference value	Par. 6-14	Par. 6-14	Par. 6-24	Par. 6-24	Par. 5-52	Par. 5-57
Minimum input value	Par. 6-10	Par. 6-12	Par. 6-20	Par. 6-22	Par. 5-50	Par. 5-55
	[V]	[mA]	[V]	[mA]	[Hz]	[Hz]
<b>P2 = (Maximum input value, Maximum reference value)</b>						
Maximum reference value	Par. 6-15	Par. 6-15	Par. 6-25	Par. 6-25	Par. 5-53	Par. 5-58
Maximum input value	Par. 6-11	Par. 6-13	Par. 6-21	Par. 6-23	Par. 5-51	Par. 5-56
	[V]	[mA]	[V]	[mA]	[Hz]	[Hz]

— Introduction to FC 300 —

In some cases the reference (in rare cases also the feedback) should have a Dead Band around zero (i.e. to make sure the machine is stopped when the reference is “near zero”). To make the dead band active and to set the amount of dead band, the following settings must be done:

- Either Minimum Reference Value (see table above for relevant parameter) or Maximum Reference Value must be zero. In other words; Either P1 or P2 must be on the X-axis in the graph below.
- And both points defining the scaling graph are in the same quadrant.

The size of the Dead Band is defined by either P1 or P2 as shown in the graph below.

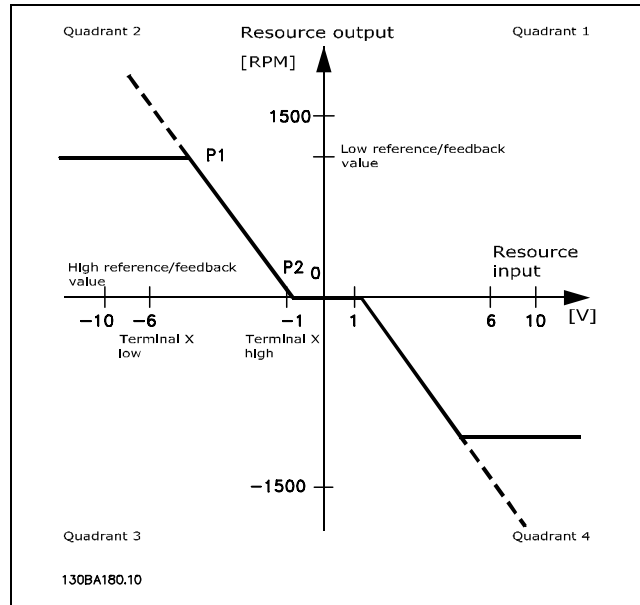
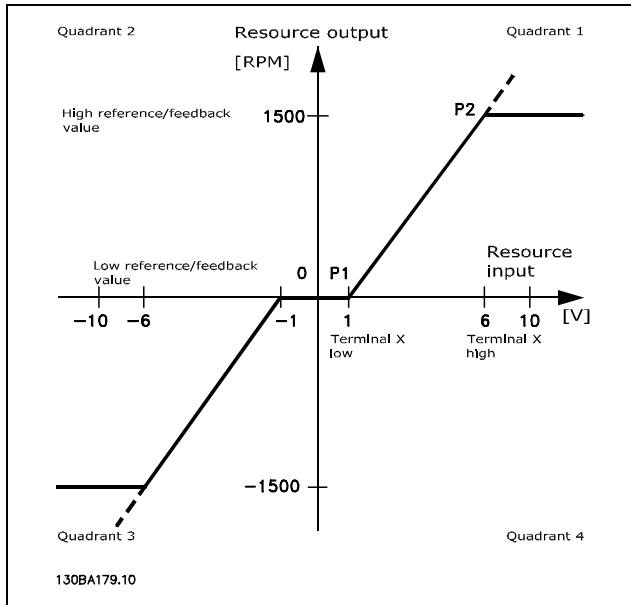

Thus a reference endpoint of  $P1 = (0 \text{ V}, 0 \text{ RPM})$  will not result in any dead band, but a reference endpoint of e.g.  $P1 = (1 \text{ V}, 0 \text{ RPM})$  will result in a -1V to +1V dead band in this case provided that the end point P2 is placed in either Quadrant 1 or Quadrant 4.

— Introduction to FC 300 —

**Case 1: Positive Reference with Dead band, Digital input to trigger reverse**

This Case shows how Reference input with limits inside Min - Max limits clamps.

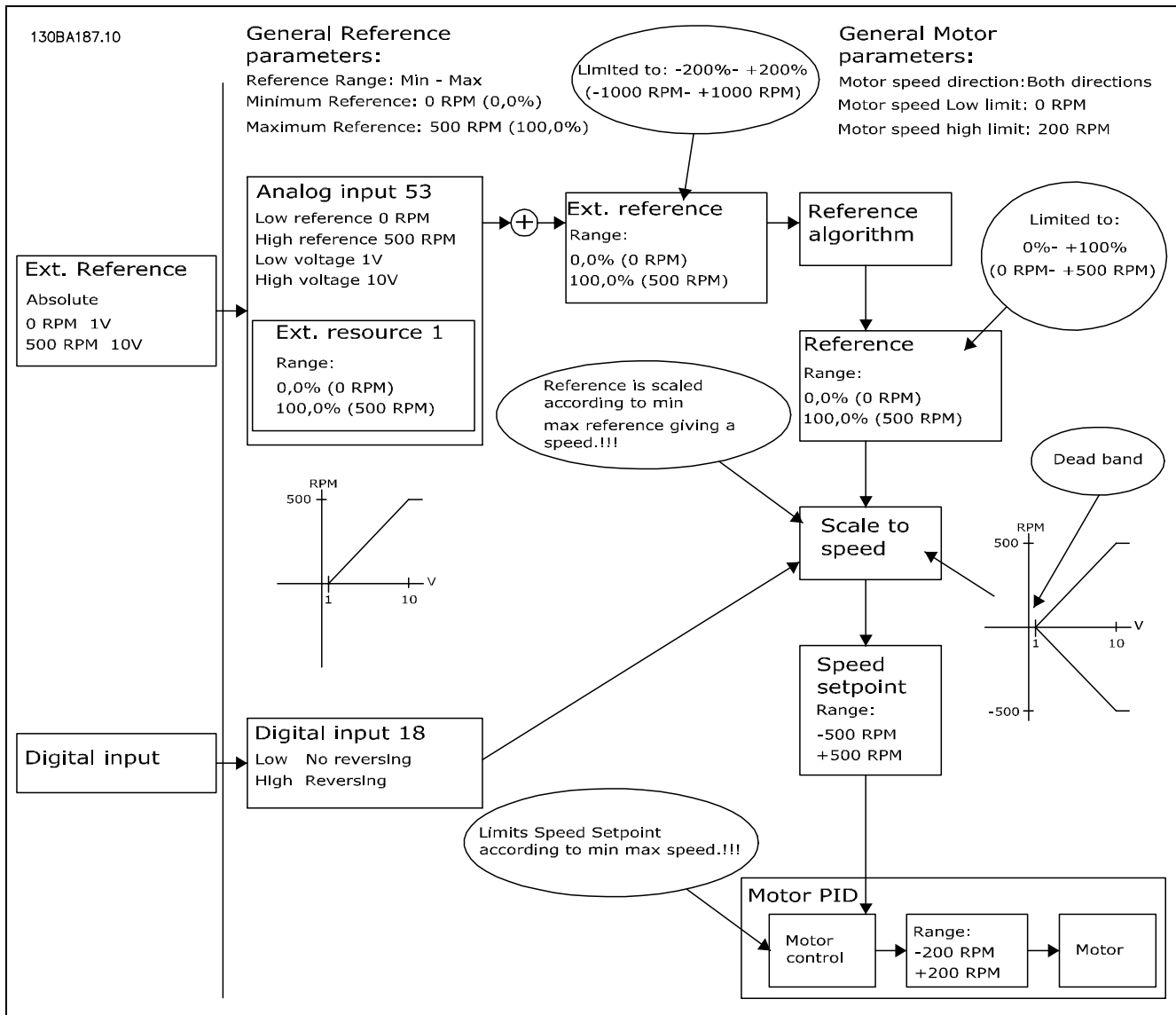

— Introduction to FC 300 —

**Case 2: Positive Reference with Dead band, Digital input to trigger reverse. Clamping rules.**

This Case shows how Reference input with limits outside -Max - +Max limits clamps to the inputs low and high limits before addition to External reference. And how the External reference is clamped to -Max - +Max by the Reference algorithm.

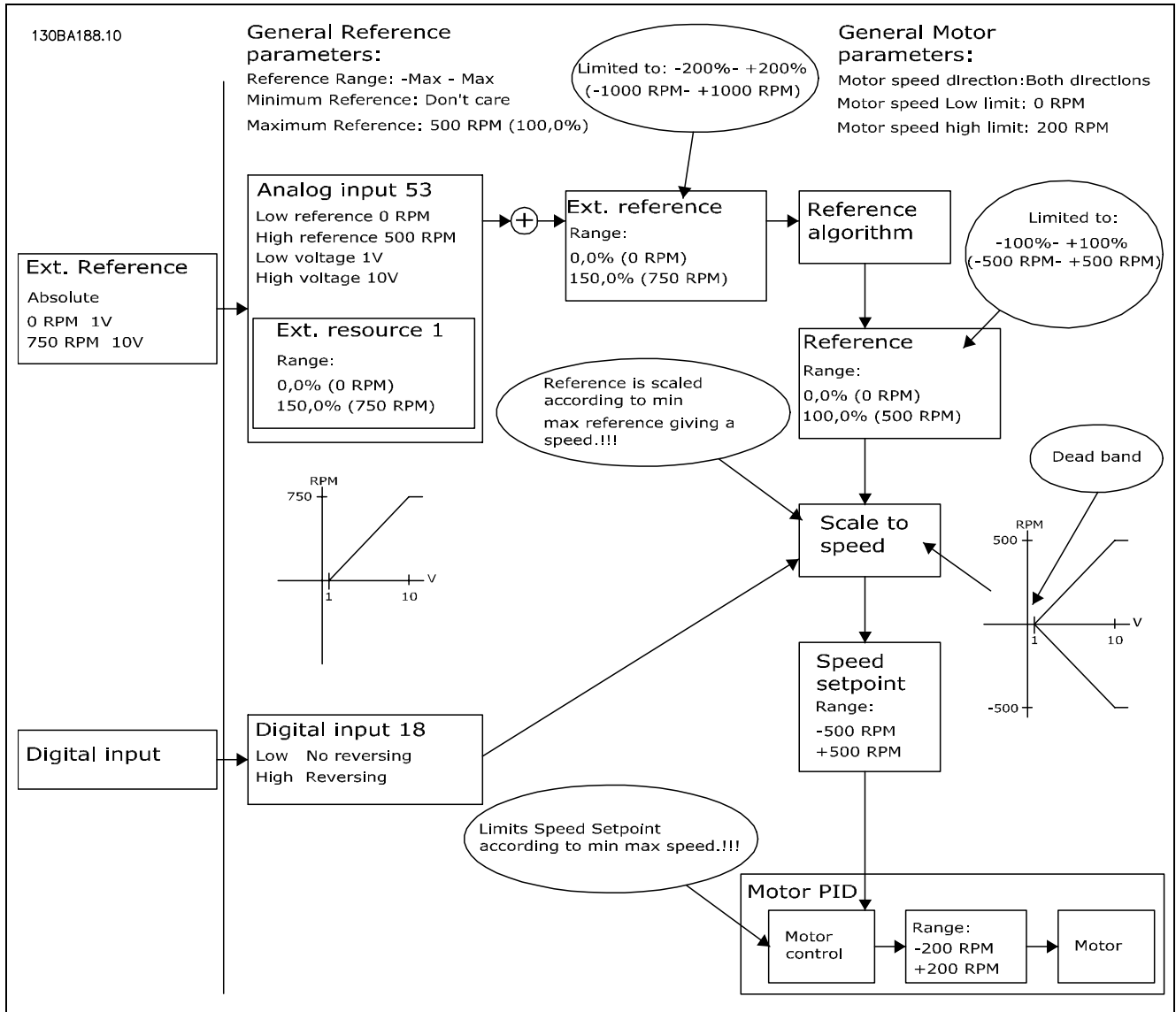

— Introduction to FC 300 —

**Case 3: Negative to positive reference with dead band, Sign determines the direction, -Max - +Max**

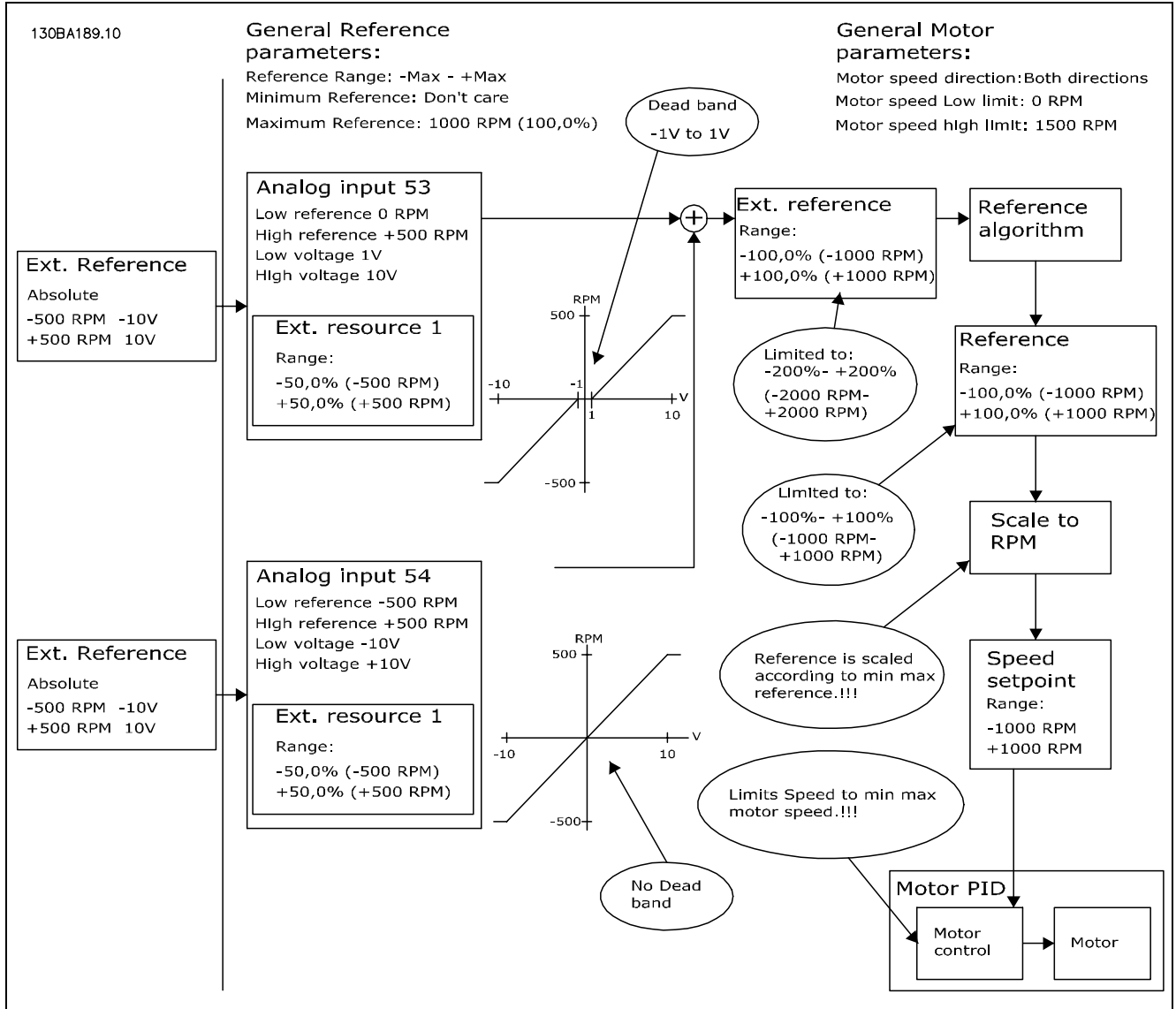

— Introduction to FC 300 —

□ **Speed PID Control**

The table shows the control configurations where the Speed Control is active.

Par. 1-00 Configuration Mode	Par. 1-01 Motor Control Principle			
	U/f	VVCplus	Flux Sensorless	Flux w/ enc. feedb
[0] Speed open loop	Not Active	Not Active	ACTIVE	N.A.
[1] Speed closed loop	N.A.	ACTIVE	N.A.	ACTIVE
[2] Torque	N.A.	N.A.	N.A.	Not Active
[3] Process		Not Active	ACTIVE	ACTIVE

Note: "N.A." means that the specific mode is not available at all. "Not Active" means that the specific mode is available but the Speed Control is not active in that mode.

Note: The Speed Control PID will work under the default parameter setting, but tuning the parameters is highly recommended to optimize the motor control performance. The two Flux motor control principles are specially dependant on proper tuning to yield their full potential.

The following parameters are relevant for the Speed Control:

Parameter	Description of function	
Feedback Par. 7-00	Select from which input the Speed PID should get its feedback.	
Proportional Gain Par. 7-02	The higher the value - the quicker the control. However, too high value may lead to oscillations.	
Integral Time Par. 7-03	Eliminates steady state speed error. Lower value means quick reaction. However, too low value may lead to oscillations.	
Differentiation Time Par. 7-04	Provides a gain proportional to the rate of change of the feedback. A setting of zero disables the differentiator.	
Differentiator Gain Limit Par. 7-05	If there are quick changes in reference or feedback in a given application - which means that the error changes swiftly - the differentiator may soon become too dominant. This is because it reacts to changes in the error. The quicker the error changes, the stronger the differentiator gain is. The differentiator gain can thus be limited to allow setting of the reasonable differentiation time for slow changes and a suitably quick gain for quick changes.	
Lowpass Filter Time Par. 7-06	A low-pass filter that dampens oscillations on the feedback signal and improves steady state performance. However, too large filter time will deteriorate the dynamic performance of the Speed PID control. Practical settings of Par 7-06 taken from the number of pulses per revolution on from encoder (PPR):	
	<b>Encoder PPR</b>	<b>Par. 7-06</b>
	512	10 ms
	1024	5 ms
	2048	2 ms
	4096	1 ms

— Introduction to FC 300 —

Below is given an example of how to programme the Speed Control:

In this case the Speed PID Control is used to maintain a constant motor speed regardless of the changing load on the motor.

The required motor speed is set via a potentiometer connected to terminal 53. The speed range is 0 - 1500 RPM corresponding to 0 - 10V over the potentiometer.

Starting and stopping is controlled by a switch connected to terminal 18.

The Speed PID monitors the actual RPM of the motor by using a 24V (HTL) incremental encoder as feedback. The feedback sensor is an encoder (1024 pulses per. revolution) connected to terminals 32 and 33.

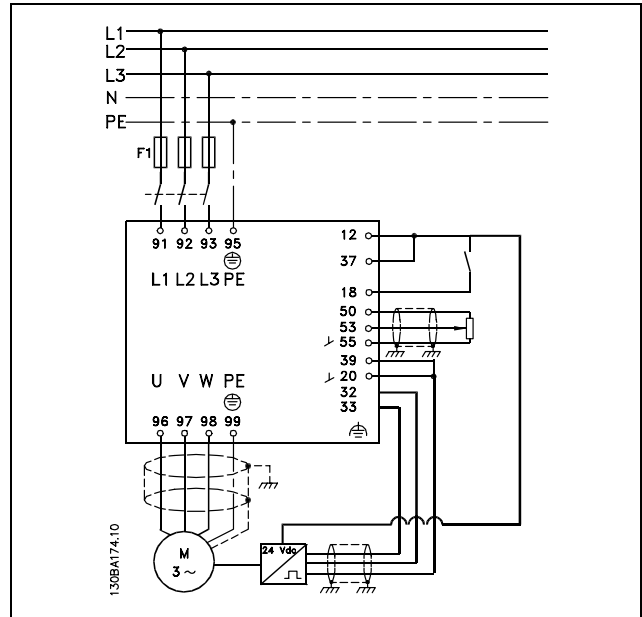

## — Introduction to FC 300 —

In the parameter list below it is assumed that all other parameters and switches remain at their default setting.

The following must be programmed in order shown - see explanation of settings in the section "How to programme".

Function	Par. no.	Setting
<b>1) Make sure the motor runs properly. Do the following:</b>		
Set the motor parameters using name plate data	1-2*	As specified by motor name plate
Have the VLT make an Automatic Motor Adaptation	1-29	[1] Enable complete AMA
<b>2) Check the motor is running and the encoder is attached properly. Do the following:</b>		
Press the "Hand On" LCP key. Check that the motor is running and note in which direction it is turning (henceforth referred to as the "positive direction").		Set a positive reference.
Go to par. 16-20. Turn the motor slowly in the positive direction. It must be turned so slowly (only a few RPM) that it can be determined if the value in par. 16-20 is increasing or decreasing.	16-20	N.A. (read-only parameter) Note: An increasing value overflows at 65535 and starts again at 0.
If par. 16-20 is decreasing then change the encoder direction in par. 5-71.	5-71	[1] Counter clockwise (if par. 16-20 is decreasing)
<b>3) Make sure the drive limits are set to safe values</b>		
Set acceptable limits for the references.	3-02 3-03	0 RPM (default) 1500 RPM (default)
Check that the ramp settings are within drive capabilities and allowed application operating specifications.	3-41 3-42	default setting default setting
Set acceptable limits for the motor speed and frequency.	4-11 4-13 4-19	0 RPM (default) 1500 RPM (default) 60 Hz (default 132 Hz)
Press the "Hand On" LCP key. Check that the motor runs and note in which direction it is turning.		Set a positive reference.
If the motor was turning in the wrong direction, remove the motor plug and switch two of the motor phases.		
<b>4) Configure the Speed Control and select the Motor Control principle</b>		
Activation of Speed Control	1-00	[1] Speed closed loop
Selection of Motor Control Principle	1-01	[3] Flux w motor feedb
<b>5) Configure and scale the reference to the Speed Control</b>		
Set up Analog Input 53 as a reference resource	3-15	Not necessary (default)
Scale Analog Input 53 0 RPM (0 V) to 1500 RPM (10V)	6-1*	Not necessary (default)
<b>6) Configure the 24V HTL encoder signal as feedback for the Motor Control and the Speed Control</b>		
Set up digital input 32 and 33 as encoder inputs	5-14 5-15	[0] No operation (default)
Choose terminal 32/33 as motor feedback	1-02	Not necessary (default)
Choose terminal 32/33 as Speed PID feedback	7-00	Not necessary (default)
<b>7) Tune the Speed Control PID parameters</b>		
Use the tuning guidelines when relevant or tune manually	7-0*	See the guidelines below
<b>8) Finished!</b>		
Save the parameter setting to the LCP for safe keeping	0-50	[1] All to LCP



## — Introduction to FC 300 —

□ **Tuning PID Speed Control**

The following tuning guidelines are relevant when using one of the Flux motor control principles in applications where the load is mainly inertial (with a low amount of friction).

The value of par. 7-02 Proportional Gain is dependent on the combined inertia of the motor and load, and the selected bandwidth can be calculated using the following formula:

$$Par.7-02 = \frac{Total\ inertia\ [kgm^2] \times Par.1 - 25}{Par. 1 - 20 \times 9550} \times Bandwidth\ [rad/s]$$

Note: Par. 1-20 is the motor power in [kW] (i.e. enter '4' kW instead of '4000' W in the formula). A practical value for the Bandwidth is 20 rad/s. Check the result of the par. 7-02 calculation against the following formula (not required if you are using a high resolution feedback such as a SinCos feedback):

$$Par.7-02_{MAXIMUM} = \frac{0.01 \times 4 \times Encoder\ Resolution \times par. 7 - 06}{2 \times \pi} \times MaxTorqueRipple\ [%]$$

A good start value for par. 7-06 *Speed Filter Time* is 5 ms (lower encoder resolution calls for a higher filter value). Typically a Max Torque Ripple of 3 % is acceptable. For incremental encoders the Encoder Resolution is found in either par. 5-70 (24V HTL on standard drive) or par. 17-11 (5V TTL on MCB102 Option).

Generally the practical maximum limit of par. 7-02 is determined by the encoder resolution and the feedback filter time but other factors in the application might limit the par. 7-02 *Proportional Gain* to a lower value.

To minimize the overshoot, par. 7-03 *Integral Time* could be set to approx. 2.5 s (varies with the application).

Par. 7-04 *Differential Time* should be set to 0 until everything else is tuned. If necessary finish the tuning by experimenting with small increments of this setting.

— Introduction to FC 300 —

□ **Process PID Control**

The Process PID Control can be used to control application parameters that can be measured by a sensor (i.e. pressure, temperature, flow) and be affected by the connected motor through a pump, fan or otherwise.

The table shows the control configurations where the Process Control is possible. When a Flux Vector motor control principle is used, take care also to tune the Speed Control PID parameters. Refer to the section about the Control Structure to see where the Speed Control is active.

Par. 1-00	Par. 1-01 Motor Control Principle			
Configuration Mode	U/f	VVCplus	Flux Sensorless	Flux w/ enc. feedb
[3] Process	N.A.	Process	Process & Speed	Process & Speed

Note: The Process Control PID will work under the default parameter setting, but tuning the parameters is highly recommended to optimise the application control performance. The two Flux motor control principles are specially dependant on proper Speed Control PID tuning (prior to tuning the Process Control PID) to yield their full potential.

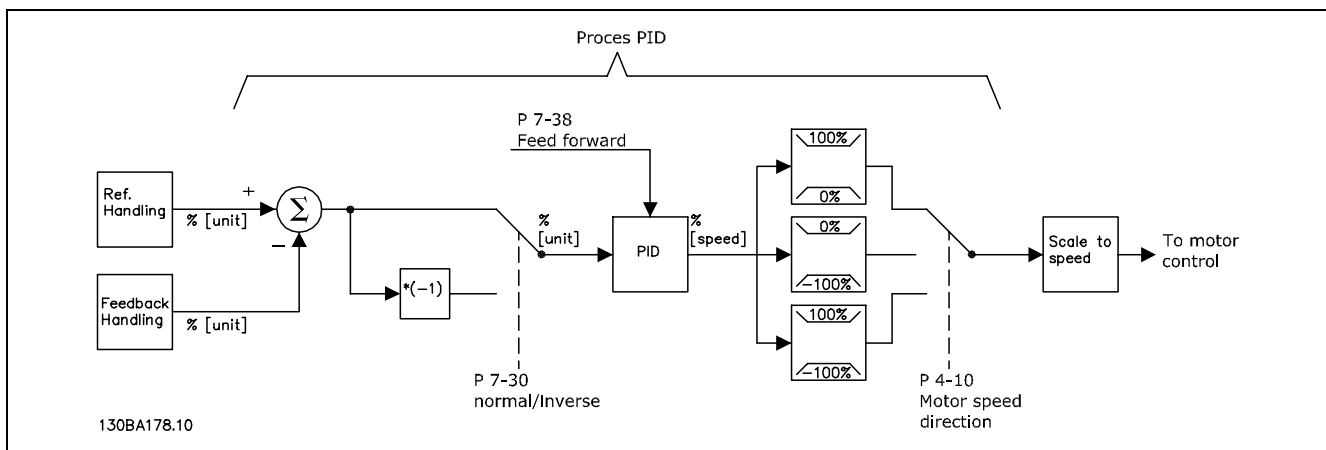

**Process PID Control diagram**

## — Introduction to FC 300 —

The following parameters are relevant for the Process Control

Parameter	Description of function
Feedback 1 Resource Par. 7-20	Select from which resource (i.e. analog or pulse input) the Process PID should get its feedback
Feedback 2 Resource Par. 7-22	Optional: Determine if (and from where) the Process PID should get an additional feedback signal. If an additional feedback source is selected the two feedback signals will be added together before being used in the Process PID Control.
Normal/inverse control Par. 7-30	Under [0] Normal operation the Process Control will respond with an increase of the motor speed if the feedback is getting lower than the reference. In the same situation, but under [1] Inverse operation, the Process Control will respond with a decreasing motor speed instead.
Anti Windup Par. 7-31	The anti windup function ensures that when either a frequency limit or a torque limit is reached, the integrator will be set to a gain that corresponds to the actual frequency. This avoids integrating on an error that cannot in any case be compensated for by means of a speed change. This function can be disabled by selecting [0] "Off".
Control Start Value Par. 7-32	In some applications, reaching the required speed/set point can take a very long time. In such applications it might be an advantage to set a fixed motor speed from the frequency converter before the process control is activated. This is done by setting a Process PID Start Value (speed) in par. 7-32.
Proportional Gain Par. 7-33	The higher the value - the quicker the control. However, too large value may lead to oscillations.
Integral Time Par. 7-34	Eliminates steady state speed error. Lower value means quick reaction. However, too small value may lead to oscillations.
Differentiation Time Par. 7-35	Provides a gain proportional to the rate of change of the feedback. A setting of zero disables the differentiator.
Differentiator Gain Limit Par. 7-36	If there are quick changes in reference or feedback in a given application - which means that the error changes swiftly - the differentiator may soon become too dominant. This is because it reacts to changes in the error. The quicker the error changes, the stronger the differentiator gain is. The differentiator gain can thus be limited to allow setting of the reasonable differentiation time for slow changes.
Feed Forward Factor Par. 7-38	In application where there is a good (and approximately linear) correlation between the process reference and the motor speed necessary for obtaining that reference, the Feed Forward Factor can be used to achieve better dynamic performance of the Process PID Control.
Lowpass Filter Time Par. 5-54 (Pulse term. 29), Par. 5-59 (Pulse term. 33), Par. 6-16 (Analog term 53), Par. 6-26 (Analog term. 54)	<p>If there are oscillations of the current/voltage feedback signal, these can be dampened by means of a low-pass filter. This time constant represents the speed limit of the ripples occurring on the feedback signal.</p> <p>Example: If the low-pass filter has been set to 0.1s, the limit speed will be 10 RAD/sec. (the reciprocal of 0.1 s), corresponding to <math>(10/(2 \times \pi)) = 1.6</math> Hz. This means that all currents/voltages that vary by more than 1.6 oscillations per second will be damped by the filter. The control will only be carried out on a feedback signal that varies by a frequency (speed) of less than 1.6 Hz.</p> <p>The low-pass filter improves steady state performance but selecting a too large filter time will deteriorate the dynamic performance of the Process PID Control.</p>

— Introduction to FC 300 —

The following is an example of a Process PID Control used in a ventilation system:

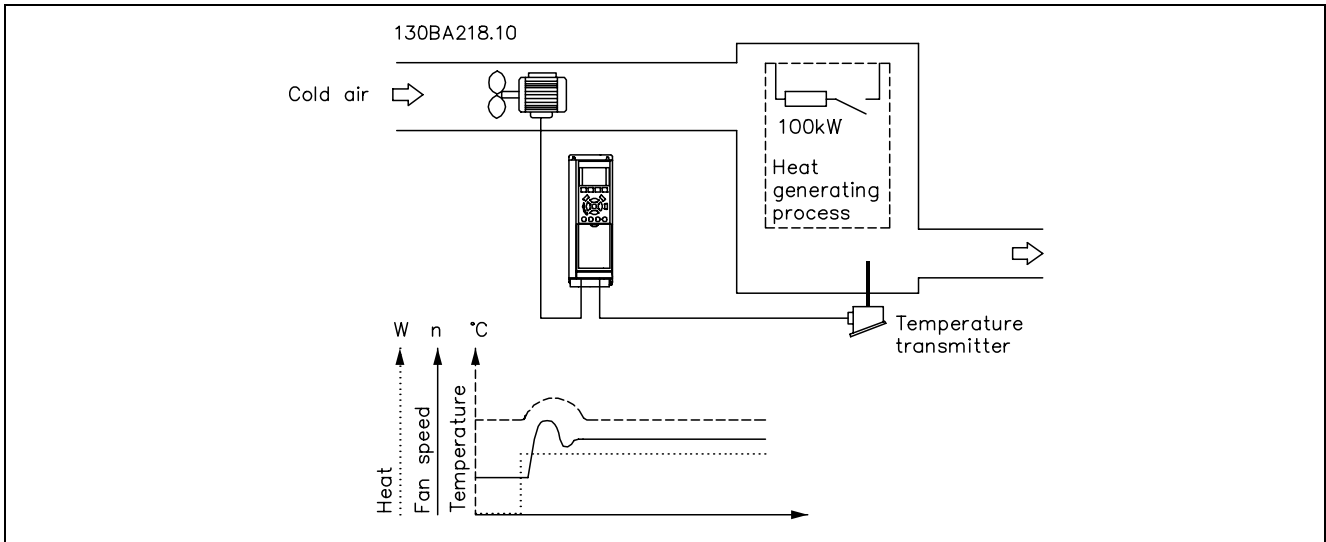

In a ventilation system, the temperature is to be settable from - 5 - 35°C with a potentiometer of 0-10 Volt. The set temperature must be kept constant, for which purpose the Process Control is to be used.

The control is of the inverse type, which means that when the temperature increases, the ventilation speed is increased as well, so as to generate more air. When the temperature drops, the speed is reduced. The transmitter used is a temperature sensor with a working range of -10-40°C, 4-20 mA. Min. / Max. speed 300 / 1500 RPM.



**NB!:**  
The example shows a two-wire transmitter.

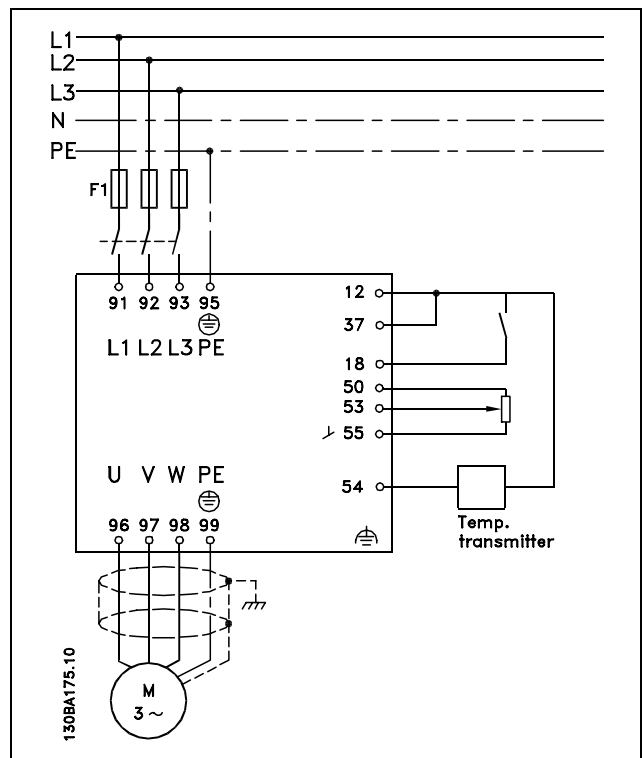

1. Start/Stop via switch connected to terminal 18.
2. Temperature reference via potentiometer (-5-35°C, 0-10 VDC) connected to terminal 53.
3. Temperature feedback via transmitter (-10-40°C, 4-20 mA) connected to terminal 54.
54. Switch S202 set to ON (current input).

## — Introduction to FC 300 —

Function	Par. no.	Setting
<b>1) Make sure the motor runs properly. Do the following:</b>		
Set the motor parameters using name plate data	1-2*	As specified by motor name plate
Have the frequency converter make an Automatic Motor Adaptation	1-29	[1] Enable complete AMA
<b>2) Check that the motor is running in the right direction.</b>		
Press the "Hand On" LCP key. Check that the motor runs and note in which direction it is turning.		Set a positive reference.
If the motor was turning in the wrong direction, remove the motor plug and switch two of the motor phases.		
<b>3) Make sure the frequency converter limits are set to safe values</b>		
Check that the ramp settings are within capabilities of the frequency converter and allowed application operating specifications.	3-41	60 sec.
	3-42	60 sec. Depends on motor/load size! Also active in Hand mode.
Prohibit the motor from reversing if necessary	4-10	[0] Clockwise
Set acceptable limits for the motor speed and frequency	4-11	300 RPM
	4-13	1500 RPM (default)
	4-19	60 Hz (default 132 Hz)
<b>4) Configure the reference to the Process Control</b>		
Allow for an "asymmetrical" reference range by selecting the "Min - Max" Reference Range	3-00	[0] Min - Max
Select the appropriate reference unit	3-01	[13] °C
Set acceptable limits for the sum of all references	3-02	-5 °C
	3-03	35 °C
Set up Analog Input 53 as a reference resource	3-15	Not necessary (default)
<b>5) Scale the analog inputs used for reference and feedback</b>		
Scale the Analog Input 1 (terminal 53) that is used for the temperature reference via potentiometer (-5-35°C, 0-10 VDC).	6-10	0 VDC
	6-11	10 VDC
	6-14	-5 °C
	6-15	35 °C
Scale the Analog Input 2 (terminal 54) that is used for the temperature feedback via transmitter (-10-40°C, 4-20 mA)	6-22	4 mA
	6-23	20 mA
	6-24	-10 °C
	6-25	40 °C
	6-26	50 ms - 100 ms
<b>6) Configure the feedback to the Process Control</b>		
Set up Analog Input 54 as a feedback resource	7-20	[2] Analog input 54
<b>7) Tune the Process Control PID parameters</b>		
Select inverse control.	7-30	[1] Inverse
Use the tuning guidelines when relevant or tune manually	7-3*	See the guidelines below
<b>8) Finished!</b>		
Save the parameter setting to the LCP for safe keeping	0-50	[1] All to LCP

— Introduction to FC 300 —

Optimisation of the process regulator

The basic settings have now been made; all that needs to be done is to optimise the proportional gain, the integration time and the differentiation time (par. 7-33, 7-34, 7-35). In most processes, this can be done by following the guidelines given below.

1. Start the motor
2. Set par. 7-33 (*Proportional Gain*) to 0.3 and increase it until the feedback signal again begins to vary continuously. Then reduce the value until the feedback signal has stabilised. Now lower the proportional gain by 40-60%.
3. Set par. 7-34 (*Integration Time*) to 20 sec. and reduce the value until the feedback signal again begins to vary continuously. Increase the integration time until the feedback signal stabilises, followed by an increase of 15-50%.
4. Only use par. 7-35 for very fast-acting systems only (*differentiation time*). The typical value is four times the set integration time. The differentiator should only be used when the setting of the proportional gain and the integration time has been fully optimised. Make sure that oscillations on the feedback signal is sufficiently dampened by the lowpass filter on the feedback signal.



**NB!:**

If necessary, start/stop can be activated a number of times in order to provoke a variation of the feedback signal.

□ **Ziegler Nichols Tuning Method**

In order to tune the PID controls of the frequency converter, several tuning methods can be used. One approach is to use a technique which was developed in the 1950s but which has stood the test of time and is still used today. This method is known as the Ziegler Nichols tuning.



**NB!:**

The method described must not be used on applications that could be damaged by the oscillations created by marginally stable control settings.

The criteria for adjusting the parameters are based on evaluating the system at the limit of stability rather than on taking a step response. We increase the proportional gain until we observe continuous oscillations (as measured on the feedback), that is, until the system becomes marginally stable. The corresponding gain ( $K_u$ ) (called the ultimate gain) and the period of the oscillation ( $P_u$ ) (also called the ultimate period) are determined as shown in Figure 1.

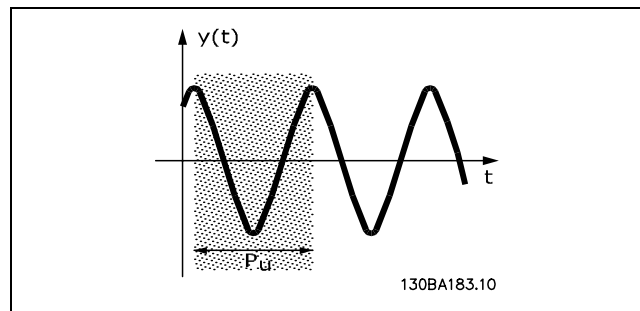

Figure 1: Marginally stable system

$P_u$  should be measured when the amplitude of oscillation is quite small. Then we “back off” from this gain again, as shown in Table 1.

$K_u$  is the gain at which the oscillation is obtained.

Type of Control	Proportional Gain	Integral Time	Differentiation Time
PI-control	$0.45 * K_u$	$0.833 * P_u$	-
PID tight control	$0.6 * K_u$	$0.5 * P_u$	$0.125 * P_u$
PID some overshoot	$0.33 * K_u$	$0.5 * P_u$	$0.33 * P_u$

Table 1: Ziegler Nichols tuning for regulator, based on a stability boundary.

## — Introduction to FC 300 —

Experience has shown that the control setting according to Ziegler Nichols rule provides a good closed loop response for many systems. The process operator can do the final tuning of the control iteratively to yield satisfactory control.

**Step-by-step Description:**

**Step 1:** Select only Proportional Control, meaning that the Integral time is selected to the maximum value, while the differentiation time is selected to zero.

**Step 2:** Increase the value of the proportional gain until the point of instability is reached (sustained oscillations) and the critical value of gain,  $K_u$ , is reached.

**Step 3:** Measure the period of oscillation to obtain the critical time constant,  $P_u$ .

**Step 4:** Use the table above to calculate the necessary PID control parameters.

— Introduction to FC 300 —

□ **General Aspects of EMC Emissions**

Electrical interference is usually conducted at frequencies in the range 150 kHz to 30 MHz. Airborne interference from the drive system in the range 30 MHz to 1 GHz is generated from the inverter, motor cable, and the motor. As shown in the illustration below, capacitive currents in the motor cable coupled with a high  $dV/dt$  from the motor voltage generate leakage currents.

The use of a screened motor cable increases the leakage current (see illustration below) because screened cables have higher capacitance to earth than unscreened cables. If the leakage current is not filtered, it will cause greater interference on the mains in the radio frequency range below approx. 5 MHz. Since the leakage current ( $I_1$ ) is carried back to the unit through the screen ( $I_3$ ), there will in principle only be a small electro-magnetic field ( $I_4$ ) from the screened motor cable according to the below figure.

The screen reduces the radiated interference but increases the low-frequency interference on the mains. The motor cable screen must be connected to the frequency converter enclosure as well as on the motor enclosure. This is best done by using integrated screen clamps so as to avoid twisted screen ends (pigtailed). These increase the screen impedance at higher frequencies, which reduces the screen effect and increases the leakage current ( $I_4$ ).

If a screened cable is used for Profibus, standard bus, relay, control cable, signal interface, and brake, the screen must be mounted on the enclosure at both ends. In some situations, however, it will be necessary to break the screen to avoid current loops.

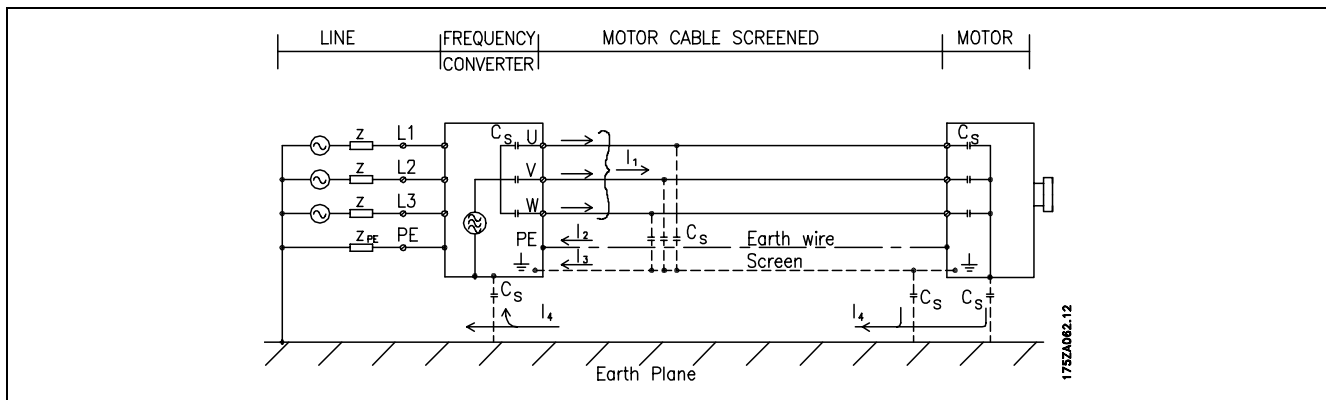

If the screen is to be placed on a mounting plate for the frequency converter, the mounting plate must be made of metal, because the screen currents have to be conveyed back to the unit. Moreover, ensure good electrical contact from the mounting plate through the mounting screws to the frequency converter chassis.



**NB!:**

When unscreened cables are used, some emission requirements are not complied with, although the immunity requirements are observed.

In order to reduce the interference level from the entire system (unit + installation), make motor and brake cables as short as possible. Avoid placing cables with a sensitive signal level alongside motor and brake cables. Radio interference higher than 50 MHz (airborne) is especially generated by the control electronics.



<b>EMC Test Results (Emission, Immunity)</b>					
The following test results have been obtained using a system with a frequency converter (with options if relevant), a screened control cable, a control box with potentiometer, as well as a motor and motor screened cable.					
FC 301/FC 302 200-240 V 380-500 V 600 V no filter	Conducted emission			Radiated emission	
	Industrial environment		Housing, trades and light industries	Industrial environment	Housing, trades and light industries
Setup	EN 55011 Class A2	EN 55011 Class A1	EN 55011 Class B	EN 55011 Class A1	EN 55011 Class B
FC 301/FC 302 H2 0-3.7 kW 200-240 V	5 m	No	No	No	No
0-7.5 kW 380-500 V	5 m	No	No	No	No
FC 301 with integrated filter H1 0-3.7 kW 200-240 V	75 m	50 m	10 m	Yes	No
0-7.5 kW 380-480 V	75 m	50 m	10 m	Yes	No
FC 302 with integrated filter H1 0-3.7 kW 200-240 V	150 m	150 m	40 m	Yes	No
0-7.5 kW 380-500 V	150 m	150 m	40 m	Yes	No
FC 301 11-22 kW 380-500 V	25 m	No	No	No	No
FC 302 11-22 kW 380-500 V	25 m	No	No	No	No
FC 301 with integrated filter H1 11-22 kW 380-500 V	75 m	50 m	10 m	Yes	No
FC 302 with integrated filter H2 11-22 kW 380-500 V	150 m	150 m	40 m	Yes	No

Hx is without filter

□ **Required Compliance Levels**

Standard / environment	Housing, trades, and light industries		Industrial environment	
	Conducted	Radiated	Conducted	Radiated
IEC 61000-6-3 (generic)	Class B	Class B		
IEC 61000-6-4			Class A1	Class A1
EN 61800-3 (restricted)	Class A1	Class A1	Class A1	Class A1
EN 61800-3 (unrestricted)	Class B	Class B	Class A2	Class A2

EN 55011: Threshold values and measuring methods for radio interference from industrial, scientific and medical (ISM) high-frequency equipment.

Class A1: Equipment used in a public supply network. Restricted distribution.

Class A2: Equipment used in a public supply network.

Class B1: Equipment used in areas with a public supply network (dwellings, commerce, and light industries). Unrestricted distribution.

□ **EMC Immunity**

In order to document immunity against electrical interference from electrical phenomena, the following immunity tests have been made on a system consisting of a frequency converter (with options, if relevant), a screened control cable, and a control box with potentiometer, motor cable, and motor.

The tests were performed in accordance with the following basic standards:

- **EN 61000-4-2 (IEC 61000-4-2): Electrostatic discharges (ESD)**  
Simulation of electrostatic discharges from human beings.
- **EN 61000-4-3 (IEC 61000-4-3): Incoming electromagnetic field radiation, amplitude modulated**  
Simulation of the effects of radar and radio communication equipment as well as mobile communications.
- **EN 61000-4-4 (IEC 61000-4-4): Burst transients**  
Simulation of interference brought about by switching with a contactor, relays, or similar devices.
- **EN 61000-4-5 (IEC 61000-4-5): Surge transients**  
Simulation of transients brought e.g. by lightning that strikes near installations.
- **EN 61000-4-6 (IEC 61000-4-6): RF Common mode**  
Simulation of the effect from radio-transmitting equipment connected to connection cables.

See following EMC immunity form.

— Introduction to FC 300 —

**Immunity continued**

FC 301/FC 302; 200-240 V, 380-500 V

Basic standard	Burst IEC 61000-4-4	Surge IEC 61000-4-5	ESD IEC 61000-4-2	Radiated electromagnetic field IEC 61000-4-3	RF common mode voltage IEC 61000-4-6
Acceptance criterion	B	B	B	A	A
Line	4 kV CM	2 kV/2 Ω DM 4 kV/12 Ω CM	—	—	10 V <sub>RMS</sub>
Motor	4 kV CM	4 kV/2 Ω <sup>1)</sup>	—	—	10 V <sub>RMS</sub>
Brake	4 kV CM	4 kV/2 Ω <sup>1)</sup>	—	—	10 V <sub>RMS</sub>
Load sharing	4 kV CM	4 kV/2 Ω <sup>1)</sup>	—	—	10 V <sub>RMS</sub>
Control wires	2 kV CM	2 kV/2 Ω <sup>1)</sup>	—	—	10 V <sub>RMS</sub>
Standard bus	2 kV CM	2 kV/2 Ω <sup>1)</sup>	—	—	10 V <sub>RMS</sub>
Relay wires	2 kV CM	2 kV/2 Ω <sup>1)</sup>	—	—	10 V <sub>RMS</sub>
Application and Fieldbus options	2 kV CM	2 kV/2 Ω <sup>1)</sup>	—	—	10 V <sub>RMS</sub>
LCP cable	2 kV CM	2 kV/2 Ω <sup>1)</sup>	—	—	10 V <sub>RMS</sub>
External 24 V DC	2 kV CM	0.5 kV/2 Ω DM 1 kV/12 Ω CM	—	—	10 V <sub>RMS</sub>
Enclosure	—	—	8 kV AD 6 kV CD	10 V/m	—

AD: Air Discharge  
 CD: Contact Discharge  
 CM: Common mode  
 DM: Differential mode

1. Injection on cable shield.

— Introduction to FC 300 —

□ **Galvanic Isolation (PELV)**

PELV offers protection by way of extra low voltage. Protection against electric shock is ensured when the electrical supply is of the PELV type and the installation is made as described in local/national regulations on PELV supplies.

All control terminals and relay terminals 01-03/04-06 comply with PELV (Protective Extra Low Voltage) (Does not apply to 525-600 V units and at grounded Delta leg above 300 V).

Galvanic (ensured) isolation is obtained by fulfilling requirements for higher isolation and by providing the relevant creepage/clearance distances. These requirements are described in the EN 61800-5-1 standard.

The components that make up the electrical isolation, as described below, also comply with the requirements for higher isolation and the relevant test as described in EN 61800-5-1.

The PELV galvanic isolation can be shown in six locations (see illustration):

In order to maintain PELV all connections made to the control terminals must be PELV, e.g. thermistor must be reinforced/double insulated.

1. Power supply (SMPS) incl. signal isolation of  $U_{DC}$ , indicating the intermediate current voltage.
2. Gate drive that runs the IGBTs (trigger transformers/opto-couplers).
3. Current transducers.
4. Opto-coupler, brake module.
5. Internal inrush, RFI, and temperature measurement circuits.
6. Custom relays.

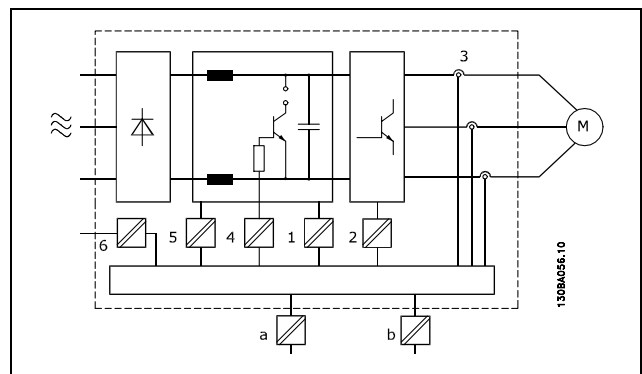

Galvanic isolation

The functional galvanic isolation (a and b on drawing) is for the 24 V back-up option and for the RS 485 standard bus interface.

## □ Earth Leakage Current



### **Warning:**

Touching the electrical parts may be fatal - even after the equipment has been disconnected from mains.

Also make sure that other voltage inputs have been disconnected, such as load-sharing (linkage of DC intermediate circuit), as well as the motor connection for kinetic back-up.

Using VLT AutomationDrive FC 300: wait at least 15 minutes.

Shorter time is allowed only if indicated on the nameplate for the specific unit.



### **Leakage Current**

The earth leakage current from the FC 300 exceeds 3.5 mA. To ensure that the earth cable has a good mechanical connection to the earth connection (terminal 95), the cable cross section must be at least 10 mm<sup>2</sup> or 2 rated earth wires terminated separately.

### **Residual Current Device**

This product can cause a d.c. current in the protective conductor. Where a residual current device (RCD) is used for extra protection, only an RCD of Type B (time delayed) shall be used on the supply side of this product. See also RCD Application Note MN.90.GX.02.

Protective earthing of the frequency converter and the use of RCD's must always follow national and local regulations.

— Introduction to FC 300 —

□ **Selection of Brake Resistor**

To handle higher demands by generative braking a brake resistor is necessary. Using a brake resistor ensures that the energy is absorbed in the brake resistor and not in the frequency converter.

If the amount of kinetic energy transferred to the resistor in each braking period is not known, the average power can be calculated on the basis of the cycle time and braking time also called intermittent duty cycle. The resistor intermittent duty cycle is an indication of the duty cycle at which the resistor is active. The below figure shows a typical braking cycle.



**NB!:**

Motor suppliers often use S5 when stating the permissible load which is an expression of intermittent duty cycle.

The intermittent duty cycle for the resistor is calculated as follows:

$$\text{Duty cycle} = t_b/T$$

T = cycle time in seconds

t<sub>b</sub> is the braking time in seconds (of the cycle time)

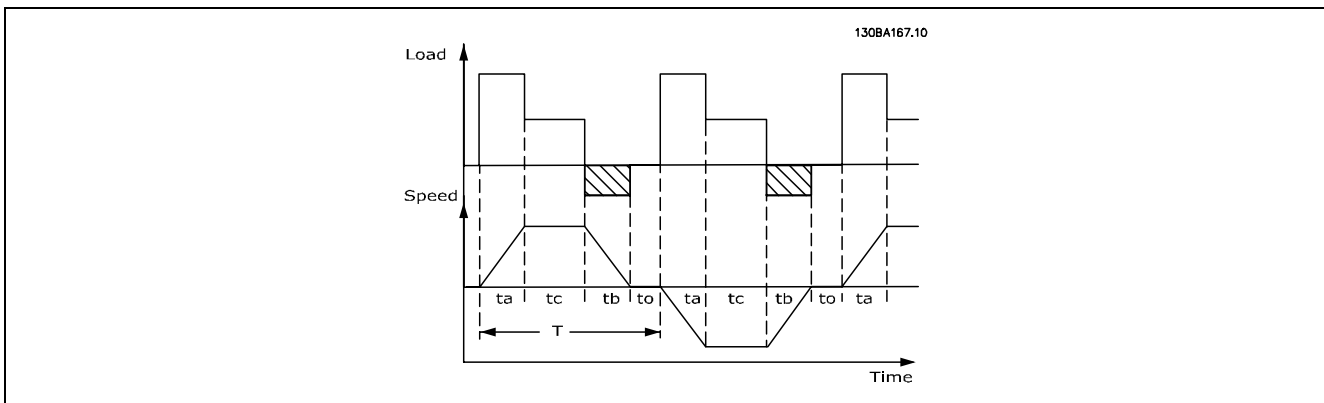

Danfoss offers brake resistors with duty cycle of 5%, 10% and 40%. If a 10% duty cycle is applied, the brake resistors are able to absorb brake power for 10% of the cycle time. The remaining 90% of the cycle time will be used on deflecting excess heat.

The max. permissible load on the brake resistor is stated as a peak power at a given intermittent duty cycle and can be calculated as:

$$P_{PEAK} = P_{MOTOR} \times M_{BR(\%)} \times \eta_{MOTOR} \times \eta_{VLT} [W]$$

The brake resistance is calculated as shown:

$$R_{br} = \frac{U_{dc}^2}{P_{peak}} = [\Omega]$$

As can be seen, the brake resistance depends on the intermediate circuit voltage (UDC).

The FC 301 and FC 302 brake function is settled in 3 areas of mains:

Size	Brake active	Warning before cut out	Cut out (trip)
FC 301 / 302 3 x 200-240 V	390 V (UDC)	405 V	410 V
FC 301 3 x 380-480 V	778 V	810 V	820 V
FC 302 3 x 380-500 V	810 V	840 V	850 V
FC 302 3 x 525-600 V	943 V	965 V	975 V

## — Introduction to FC 300 —

**NB!:**

Check that the brake resistor can cope with a voltage of 410 V, 820 V, 850 V or 975 V - unless Danfoss brake resistors are used.

Danfoss recommends the brake resistance  $R_{REC}$ , i.e. one that guarantees that the frequency converter is able to brake at the highest braking torque ( $M_{br}$ ) of 160%. The formula can be written as:

$$R_{rec} = \frac{U_{dc}^2 \times 100}{P_{motor} \times M_{BR}(\%) \times \eta_{vlt} \times \eta_{motor}} = [\Omega]$$

$\eta_{motor}$  is typically at 0.90

$\eta_{VLT}$  is typically at 0.98

For 200 V, 480 V, 500 V and 600 V frequency converters,  $R_{REC}$  at 160% braking torque is written as:

$$200V : R_{REC} = \frac{107780}{P_{MOTOR}} \quad [\Omega]$$

$$1. \quad 480 V : R = \frac{375300}{P_{MOTOR}} \quad [\Omega]$$

$$2. \quad 480 V : R = \frac{428914}{P_{MOTOR}} \quad [\Omega]$$

$$500 V : R_{REC} = \frac{464923}{P_{MOTOR}} \quad [\Omega]$$

$$600 V : R_{REC} = \frac{630137}{P_{MOTOR}} \quad [\Omega]$$

1. For FC 300 frequency converters  $\leq 7.5$  kW shaft output
2. For FC 300 frequency converters  $> 7.5$  kW shaft output

**NB!:**

The resistor brake circuit resistance selected should not be higher than that recommended by Danfoss. If a brake resistor with a higher ohmic value is selected, the 160% braking torque may not be achieved because there is a risk that the frequency converter cuts out for safety reasons.

**NB!:**

If a short circuit in the brake transistor occurs, power dissipation in the brake resistor is only prevented by using a mains switch or contactor to disconnect the mains for the frequency converter. (The contactor can be controlled by the frequency converter).

## — Introduction to FC 300 —

**□ Control with Brake Function**

The brake is to limit the voltage in the intermediate circuit when the motor acts as a generator. This occurs, for example, when the load drives the motor and the power accumulates on the DC link. The brake is built up as a chopper circuit with the connection of an external brake resistor. Placing the brake resistor externally offers the following advantages:

- The brake resistor can be selected on the basis of the application in question.
- The brake energy can be dissipated outside the control panel, i.e. where the energy can be utilized.
- The electronics of the frequency converter will not be overheated if the brake resistor is overloaded.

The brake is protected against short-circuiting of the brake resistor, and the brake transistor is monitored to ensure that short-circuiting of the transistor is detected. A relay/digital output can be used for protecting the brake resistor against overloading in connection with a fault in the frequency converter.

In addition, the brake makes it possible to read out the momentary power and the mean power for the latest 120 seconds. The brake can also monitor the power energizing and make sure it does not exceed a limit selected in par. 2-12. In par. 2-13, select the function to carry out when the power transmitted to the brake resistor exceeds the limit set in par. 2-12.

**NB!:**

Monitoring the brake power is not a safety function; a thermal switch is required for that purpose. The brake resistor circuit is not earth leakage protected.

*Over voltage control (OVC)* (exclusive brake resistor) can be selected as an alternative brake function in par. 2-17. This function is active for all units. The function ensures that a trip can be avoided if the DC link voltage increases. This is done by increasing the output frequency to limit the voltage from the DC link. It is a very useful function, e.g. if the ramp-down time is too short since tripping of the frequency converter is avoided. In this situation the ramp-down time is extended.



□ **Control of Mechanical Brake**

For hoisting applications, it is necessary to be able to control an electro-magnetic brake. For controlling the brake, a relay output (relay1 or relay2) or a programmed digital output (terminal 27 or 29) is required. Normally, this output must be closed for as long as the frequency converter is unable to 'hold' the motor, e.g. because of too big load. In par. 5-40 (Array parameter), par. 5-30, or par. 5-31 (digital output 27 or 29), select *mechanical brake control* [32] for applications with an electro-magnetic brake.

When *mechanical brake control* [32] is selected, the mechanical brake relay stays closed during start until the output current is above the level selected in par. 2-20 *Release Brake Current*. During stop, the mechanical brake will close when the speed is below the level selected in par. 2-21 *Activate Brake Speed [RPM]*. If the frequency converter is brought into an alarm condition, i.e. over-voltage situation, the mechanical brake immediately cuts in. This is also the case during safe stop.

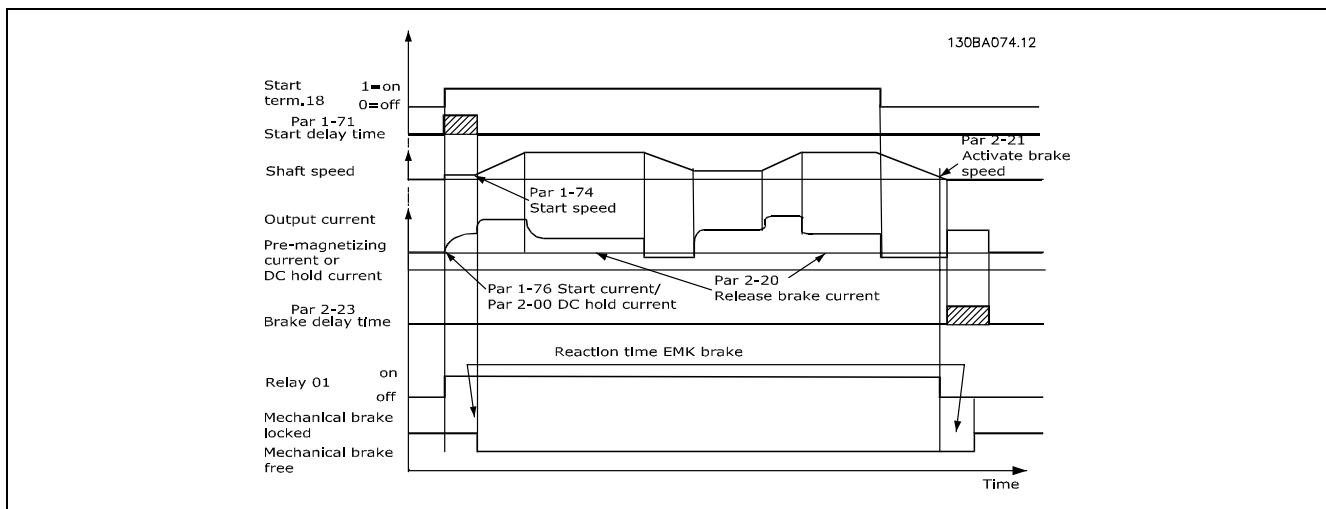

**Step-by-step Description**

In hoisting/lowering applications, it must be possible to control an electro-mechanical brake.

- To control the mechanical brake any relay output or digital output (terminal 27 or 29) can be used, if necessary use a suitable magnetic contactor.
- Ensure that the output stays voltage-free as long as the frequency converter is unable to drive the motor, for example due to the load being too heavy or due to the fact that the motor has not been dismantled yet.
- Select *Mechanical brake control* [32] in par. 5-4\* (or in par. 5-3\*) before connecting the mechanical brake.
- The brake is released when the motor current exceeds the preset value in par. 2-20.
- The brake is engaged when the output frequency is less than the frequency set in par. 2-21 or 2-22 and only if the frequency converter carries out a stop command.



**NB!:**

Check that the brake resistor is rated for 410 V (240 V units), 820 V (480 V units), 850 V (500 V units) or 975 V (600 V units) - unless Danfoss brake resistors are used.



**NB!:**

Do not touch the brake resistor as it can get very hot whilst/after braking.



**NB!:**

For vertical lifting or hoisting applications it is strongly recommended to ensure that the load can be stopped in case of an emergency or a malfunction of a single part such as a contactor, etc.

If the frequency converter is in alarm mode or in an over voltage situation, the mechanical brake cuts in.

□ **Cabelling**

EMC (twisted cables/shielding)

To reduce the electrical noise from the wires between the brake resistor and the frequency converter, the wires must be twisted.

For enhanced EMC performance a metal screen can be used.

□ **Smart Logic Control**

The Smart Logic Control (SLC) is essentially a sequence of user defined actions (see par. 13-52) executed by the SLC when the associated user defined *event* (see par. 13-51) is evaluated as TRUE by the SLC.

*Events* and *actions* are each numbered and are linked together in pairs. This means that when *event [1]* is fulfilled (attains the value TRUE), *action [1]* is executed. After this, the conditions of *event [2]* will be evaluated and if evaluated TRUE, *action [2]* will be executed and so on. Events and actions are placed in array parameters.

Only one *event* will be evaluated at any time. If an *event* is evaluated as FALSE, nothing happens (in the SLC) during the present scan interval and no other *events* will be evaluated. This means that when the SLC starts, it evaluates *event [1]* (and only *event [1]*) each scan interval. Only when *event [1]* is evaluated TRUE, the SLC executes *action [1]* and starts evaluating *event [2]*.

It is possible to program from 0 to 20 *events* and *actions*. When the last *event / action* has been executed, the sequence starts over again from *event [1] / action [1]*. The illustration shows an example with three *events / actions*:

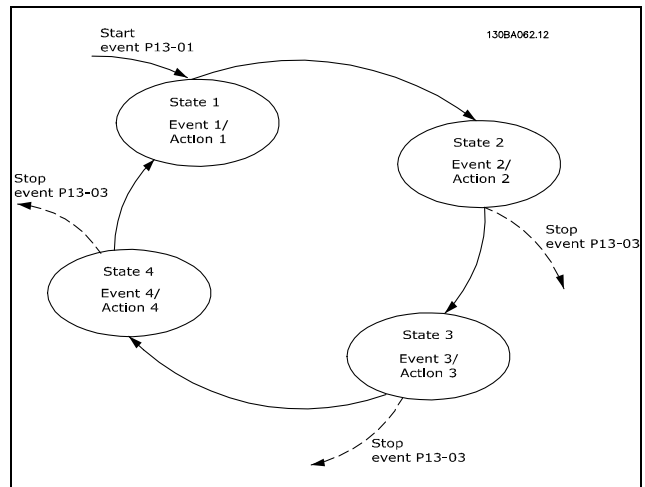

□ **Extreme Running Conditions**

**Short Circuit (Motor Phase – Phase)**

The frequency converter is protected against short circuits by means of current measurement in each of the three motor phases or in the DC link. A short circuit between two output phases will cause an overcurrent in the inverter. The inverter will be turned off individually when the short circuit current exceeds the permitted value (Alarm 16 Trip Lock).

To protect the drive against a short circuit at the load sharing and brake outputs please see the design guidelines.

**Switching on the Output**

Switching on the output between the motor and the frequency converter is fully permitted. You cannot damage the frequency converter in any way by switching on the output. However, fault messages may appear.

**Motor-generated Overvoltage**

The voltage in the intermediate circuit is increased when the motor acts as a generator. This occurs in following cases:

1. The load drives the motor (at constant output frequency from the frequency converter), ie. the load generates energy.
2. During deceleration ("ramp-down") if the moment of inertia is high, the friction is low and the ramp-down time is too short for the energy to be dissipated as a loss in the frequency converter, the motor and the installation.
3. In-correct slip compensation setting may cause higher DC link voltage.

The control unit may attempt to correct the ramp if possible (par. 2-17 *Over-voltage Control*).

The inverter turns off to protect the transistors and the intermediate circuit capacitors when a certain voltage level is reached.

See par. 2-10 and par. 2-17 to select the method used for controlling the intermediate circuit voltage level.

**Mains Drop-out**

During a mains drop-out, the frequency converter keeps running until the intermediate circuit voltage drops below the minimum stop level, which is typically 15% below the frequency converter's lowest rated supply voltage.

The mains voltage before the drop-out and the motor load determines how long it takes for the inverter to coast.

**Static Overload in VVC<sup>plus</sup> mode**

When the frequency converter is overloaded (the torque limit in par. 4-16/4-17 is reached), the controls reduces the output frequency to reduce the load.

If the overload is excessive, a current may occur that makes the frequency converter cut out after approx. 5-10 s.

Operation within the torque limit is limited in time (0-60 s) in par. 14-25.

□ **Motor Thermal Protection**

The motor temperature is calculated on the basis of motor current, output frequency, and time or thermistor. See par. 1-90 in the chapter *How to Programme*.

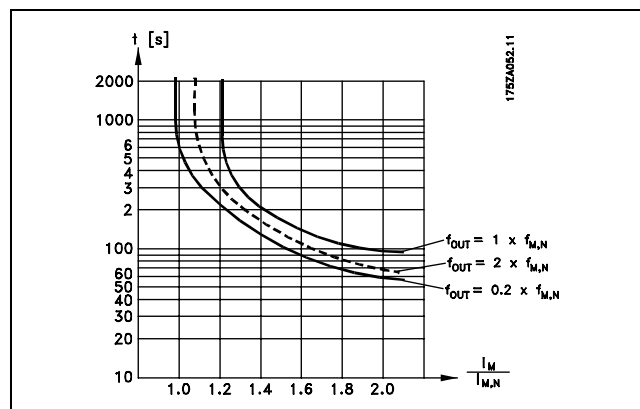

— Introduction to FC 300 —

□ **Safe Stop Operation (FC 302 Only)**

The FC 302 can perform the Safety Function “Uncontrolled Stopping by removal of power” (as defined by draft IEC 61800-5-2) or Stop Category 0 (as defined in EN 60204-1).

It is designed and approved suitable for the requirements of Safety Category 3 in EN 954-1. This functionality is called Safe Stop.

Prior to integration and use of FC 302 Safe Stop in an installation, a thorough risk analysis on the installation must be carried out in order to determine whether the FC 302 Safe Stop functionality and safety category are appropriate and sufficient.

The Safe Stop function is activated by removing the voltage at Terminal 37 of the Safe Inverter. By connecting the Safe Inverter to external safety devices providing a safe relay, an installation for a safe Stop Category 1 can be obtained. The Safe Stop function of FC 302 can be used for asynchronous and synchronous motors.



Safe Stop activation (i.e. removal of 24 V DC voltage supply to terminal 37) does not provide electrical safety.

1. Activate the Safe Stop function by removing the 24 V DC voltage supply to the terminal 37.
2. After activation of Safe Stop (i.e. after the response time), the frequency converter coasts (stops creating a rotational field in the motor). The response time is shorter than 10 ms for the complete performance range of FC 302. For FC 302 up to 7.5 kW it is even shorter than 5 ms.

The frequency converter is guaranteed not to restart creation of a rotational field by an internal fault (in accordance with Cat. 3 of EN 954-1).

After activation of Safe Stop, the FC 302 display will show the text “Safe Stop activated”. The associated help text says “Safe Stop has been activated. This means that the Safe Stop has been activated, or that normal operation has not been resumed yet after Safe Stop activation. NB: The requirements of EN 945-1 Category 3 are only fulfilled while 24 V DC supply to terminal 37 is removed or low.

In order to resume operation after activation of Safe Stop, first 24 V DC voltage must be reapplied to terminal 37 (text “Safe Stop activated” is still displayed), second a Reset signal must be created (via bus, Digital I/O, or [Reset] key on inverter).



**NB!:**

The Safe Stop function of FC 302 can be used for asynchronous and synchronous motors. It may happen that two faults occur in the frequency converter’s power semiconductor. When using synchronous motors this may cause a residual rotation. The rotation can be calculated to  $\text{Angle} = 360 / (\text{Number of Poles})$ . The application using synchronous motors must take this into consideration and ensure that this is not a safety critical issue. This situation is not relevant for asynchronous motors.



**NB!:**

In order to use the Safe Stop functionality in conformance with the requirements of EN-954-1 Category 3, a number of conditions must be fulfilled by the installation of Safe Stop. Please see section *Safe Stop Installation* for further information.



**NB!:**

The frequency converter does not provide a safety-related protection against unintended or malicious voltage supply to terminal 37 and subsequent reset. Provide this protection via the interrupt device, at the application level, or organisational level.

For more information - see section *Safe Stop Installation*.

# FC 300 Selection

## □ Electrical Data

### □ Mains Supply 3 x 200 - 240 VAC

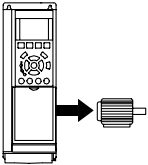
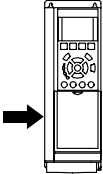
FC 301/FC 302		0.25	0.37	0.55	0.75	1.1	1.5	2.2	3	3.7	4	5.5	7.5	
Typical Shaft Output [kW]														
<b>Output current</b>														
	Continuous (3 x 200-240 V ) [A]	1.8	2.4	3.5	4.6	6.6	7.5	10.6	12.5	16.7	-	-	-	
	Intermittent (3 x 200-240 V ) [A]	2.9	3.8	5.6	7.4	10.6	12.0	17.0	20.0	26.7	-	-	-	
	Continuous KVA (208 V AC) [KVA]	0.65	0.86	1.26	1.66	2.38	2.70	3.82	4.50	6.00	-	-	-	
	Max. cable size (mains, motor, brake) [AWG] <sup>2)</sup> [mm <sup>2</sup> ]					24 - 10 AWG 0.2 - 4 mm <sup>2</sup>						-	-	-
<b>Max. input current</b>														
	Continuous (3 x 200-240 V ) [A]	1.6	2.2	3.2	4.1	5.9	6.8	9.5	11.3	15.0	-	-	-	
	Intermittent (3 x 200-240 V ) [A]	2.6	3.5	5.1	6.6	9.4	10.9	15.2	18.1	24.0	-	-	-	
	Max. pre-fuses <sup>1)</sup> [A]	10	10	10	10	20	20	20	32	32	-	-	-	
	Environment													
	Estimated power loss at rated max. load [W] <sup>4)</sup>	21	29	42	54	63	82	116	155	185	-	-	-	
<b>Enclosure IP 20</b>														
	Weight, enclosure IP20 [kg]	4.7	4.7	4.8	4.8	4.9	4.9	4.9	6.6	6.6	-	-	-	
	Efficiency <sup>4)</sup>	0.94	0.94	0.95	0.95	0.96	0.96	0.96	0.96	0.96	-	-	-	

— FC 300 Selection —

- **Mains Supply 3 x 380 - 500 VAC (FC 302)**
- 3 x 380 - 480 VAC (FC 301)**

FC 301/FC 302		0,25	0,37	0,55	0,75	1,1	1,5	2,2	3	3,7	4	5,5	7,5	
Typical Shaft Output [kW]														
<b>Output current</b>														
	Continuous (3 x 380-440 V) [A]	-	1.3	1.8	2.4	3	4.1	5.6	7.2	-	10	13	16	
	Intermittent (3 x 380-440 V) [A]	-	2.1	2.9	3.8	4.8	6.6	9.0	11.5	-	16	20.8	25.6	
	Continuous (3 x 440-500 V) [A]	-	1.2	1.6	2.1	2.7	3.4	4.8	6.3	-	8.2	11	14.5	
	Intermittent (3 x 440-500 V) [A]	-	1.9	2.6	3.4	4.3	5.4	7.7	10.1	-	13.1	17.6	23.2	
	Continuous KVA (400 V AC) [KVA]	-	0.9	1.3	1.7	2.1	2.8	3.9	5.0	-	6.9	9.0	11.0	
	Continuous KVA (460 V AC) [KVA]	-	0.9	1.3	1.7	2.4	2.7	3.8	5.0	-	6.5	8.8	11.6	
	Max. cable size (mains, motor, brake) [AWG] <sup>2)</sup> [mm <sup>2</sup> ]	-	24 - 10 AWG 0.2 - 4 mm <sup>2</sup>						-	24 - 10 AWG 0.2 - 4 mm <sup>2</sup>				
	<b>Max. input current</b>													
		Continuous (3 x 380-440 V) [A]	-	1.2	1.6	2.2	2.7	3.7	5.0	6.5	-	9.0	11.7	14.4
		Intermittent (3 x 380-440 V) [A]	-	1.9	2.6	3.5	4.3	5.9	8.0	10.4	-	14.4	18.7	23.0
Continuous (3 x 440-500 V) [A]		-	1.0	1.4	1.9	2.7	3.1	4.3	5.7	-	7.4	9.9	13.0	
Intermittent (3 x 440-500 V) [A]		-	1.6	2.2	3.0	4.3	5.0	6.9	9.1	-	11.8	15.8	20.8	
Max. pre-fuses <sup>1)</sup> [A]		-	10	10	10	10	10	20	20	-	20	32	32	
<b>Environment</b>														
Estimated power loss at rated max. load [W] <sup>4)</sup>		-	35	42	46	58	62	88	116	-	124	187	255	
<b>Enclosure IP 20</b>														
Weight, enclosure IP20 [kg]		-	4.7	4.7	4.8	4.8	4.9	4.9	4.9	-	4.9	6.6	6.6	
Efficiency <sup>4)</sup>		-	0.93	0.95	0.96	0.96	0.97	0.97	0.97	-	0.97	0.97	0.97	

— FC 300 Selection —

**Mains Supply 3 x 380 - 500 VAC**

**High Overload 160% for 1 minute**

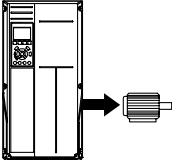
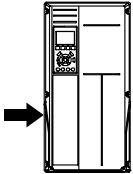
FC 302					
Typical Shaft Output [kW]		11	15	18.5	22
<b>Output current</b>					
	Continuous (3 x 380-440 V) [A]	24	32	37.5	44
	Intermittent (3 x 380-440 V) [A]	38.4	51.2	60	70.4
	Continuous (3 x 440-500 V) [A]	21	27	34	40
	Intermittent (3 x 440-500 V) [A]	33.6	43.2	54.4	64
	Continuous KVA (400 V AC) [KVA]	16.6	22.2	26	30.5
	<b>Max. input current</b>				
	Continuous (3 x 380-440 V) [A]	22	30	35	42
	Intermittent (3 x 380-440 V) [A]	35.2	48	56	67.2
	Continuous (3 x 440-500 V) [A]	20	25	32	38
	Intermittent (3 x 440-500 V) [A]	32	40	51.2	60.8
	Max. cable size [mm <sup>2</sup> / AWG] <sup>2)</sup>	16/6	16/6	35/2	35/2
	Max. pre-fuses [A] <sup>1)</sup>	63	63	63	80
	Estimated power loss at rated max. load [W] <sup>4)</sup>	272	382	454	513
	<b>Enclosure IP 21, IP 55</b>				
Weight, enclosure IP21, IP 55 [kg]	23	23	28	28	
Efficiency <sup>4)</sup>	0.98	0.98	0.98	0.98	

— FC 300 Selection —

**Mains Supply 3 x 380 - 500 VAC**

**Normal Overload 110% for 1 minute**

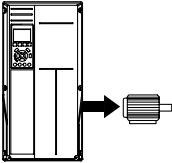
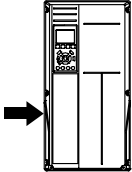
FC 302		15	18.5	22	30	
Typical Shaft Output [kW]		15	18.5	22	30	
<b>Output current</b>						
	Continuous (3 x 380-440 V) [A]	32	37.5	44	61	
	Intermittent (3 x 380-440 V) [A]	35.2	41.3	48.4	67.1	
	Continuous (3 x 440-500 V) [A]	27	34	40	52	
	Intermittent (3 x 440-500 V) [A]	29.7	37.4	44	57.2	
	Continuous kVA (400 V AC) [kVA]	22.2	26	30.5	42.3	
	Continuous kVA (460 V AC) [kVA]	21.5	27.1	31.9	41.4	
<b>Max. input current</b>						
	Continuous (3 x 380-440 V) [A]	30	35	42	58	
	Intermittent (3 x 380-440 V) [A]	33	38.5	46.2	63.8	
	Continuous (3 x 440-500 V) [A]	25	32	38	49	
	Intermittent (3 x 440-500 V) [A]	27.5	35.2	41.8	53.9	
	Max. cable size [mm <sup>2</sup> / AWG] <sup>2)</sup>	16/6	16/6	35/2	35/2	
	Max. pre-fuses [A] <sup>1)</sup>	63	63	63	80	
	Estimated power loss at rated max. load [W] <sup>4)</sup>	382	454	513	721	
	Enclosure IP 21, IP 55					
	Weight, enclosure IP21, IP 55 [kg]	23	23	28	28	
	Efficiency <sup>4)</sup>	0.98	0.98	0.98	0.98	



— FC 300 Selection —

□ **Mains Supply 3 x 525 - 600 VAC (FC 302 only)**

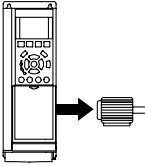
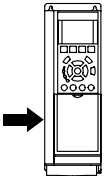
FC 302	0.25	0.37	0.55	0.75	1.1	1.5	2.2	3	3.7	4	5.5	7.5		
Typical Shaft Output [kW]														
<b>Output current</b>														
	Continuous (3 x 525-550 V ) [A]	-	-	-	1.8	2.6	2.9	4.1	5.2	-	6.4	9.5	11.5	
	Intermittent (3 x 525-550 V ) [A]	-	-	-	2.9	4.2	4.6	6.6	8.3	-	10.2	15.2	18.4	
	Continuous (3 x 525-600 V ) [A]	-	-	-	1.7	2.4	2.7	3.9	4.9	-	6.1	9.0	11.0	
	Intermittent (3 x 525-600 V ) [A]	-	-	-	2.7	3.8	4.3	6.2	7.8	-	9.8	14.4	17.6	
	Continuous kVA (525 V AC) [kVA]	-	-	-	1.7	2.5	2.8	3.9	5.0	-	6.1	9.0	11.0	
	Continuous kVA (575 V AC) [kVA]	-	-	-	1.7	2.4	2.7	3.9	4.9	-	6.1	9.0	11.0	
	Max. cable size (mains, motor, brake) [AWG] <sup>2)</sup> [mm <sup>2</sup> ]	-	-	-			24 - 10 AWG 0.2 - 4 mm <sup>2</sup>			-		24 - 10 AWG 0.2 - 4 mm <sup>2</sup>		
	<b>Max. input current</b>													
		Continuous (3 x 525-600 V ) [A]	-	-	-	1.7	2.4	2.7	4.1	5.2	-	5.8	8.6	10.4
		Intermittent (3 x 525-600 V ) [A]	-	-	-	2.7	3.8	4.3	6.6	8.3	-	9.3	13.8	16.6
Max. pre-fuses <sup>1)</sup> [A]		-	-	-	10	10	10	20	20	-	20	32	32	
<b>Environment</b>														
Estimated power loss at rated max. load [W] <sup>4)</sup>		-	-	-	35	50	65	92	122	-	145	195	261	
<b>Enclosure IP 20</b>														
Weight, enclosure IP20 [kg]		-	-	-	6.5	6.5	6.5	6.5	6.5	-	6.5	6.6	6.6	
Efficiency <sup>4)</sup>	-	-	-	0.97	0.97	0.97	0.97	0.97	-	0.97	0.97	0.97		

1) For type of fuse see section *Fuses*.

2) American Wire Gauge.

3) Measured using 5 m screened motor cables at rated load and rated frequency.

4) The typical power loss is at nominal load conditions and expected to be within +/-15% (tolerance relates to variety in voltage and cable conditions).

Values are based on a typical motor efficiency (eff2/eff3 border line). Lower efficient motors will also add to the power loss in the frequency converter and opposite.

If the switching frequency is raised from nominal the power losses may rise significantly.

LCP and typical control card power consumptions are included. Further options and customer load may add up to 30W to the losses. (Though typical only 4W extra for a fully loaded control card, or options for slot A or slot B, each).

Although measurements are made with state of the art equipment, some measurement inaccuracy must be allowed for (+/-5%).

## □ General Specifications

### Protection and Features:

---

- Electronic thermal motor protection against overload.
- Temperature monitoring of the heatsink ensures that the frequency converter trips if the temperature reaches  $95\text{ °C} \pm 5\text{ °C}$ . An overload temperature cannot be reset until the temperature of the heatsink is below  $70\text{ °C} \pm 5\text{ °C}$  (Guideline - these temperatures may vary for different power sizes, enclosures etc.).
- The frequency converter is protected against short-circuits on motor terminals U, V, W.
- If a mains phase is missing, the frequency converter trips or issues a warning (depending on the load).
- Monitoring of the intermediate circuit voltage ensures that the frequency converter trips if the intermediate circuit voltage is too low or too high.
- The frequency converter is protected against earth faults on motor terminals U, V, W.

### Mains supply (L1, L2, L3):

---

Supply voltage .....	200-240 V $\pm 10\%$
Supply voltage .....	FC 301: 380-480 V / FC 302: 380-500 V $\pm 10\%$
Supply voltage .....	FC 302: 525-600 V $\pm 10\%$
Supply frequency .....	50/60 Hz
Max. imbalance temporary between mains phases .....	3.0 % of rated supply voltage
True Power Factor ( $\lambda$ ) .....	$\geq 0.9$ nominal at rated load
Displacement Power Factor ( $\cos \phi$ ) near unity .....	(> 0.98)
Switching on input supply L1, L2, L3 (power-ups) $\leq 7.5$ kW .....	maximum 2 times/min.
Switching on input supply L1, L2, L3 (power-ups) $\geq 11$ kW .....	maximum 1 time/min.
Environment according to EN60664-1 .....	overvoltage category III/pollution degree 2

*The unit is suitable for use on a circuit capable of delivering not more than 100.000 RMS symmetrical Amperes, 240/500/600 V maximum.*

### Motor output (U, V, W):

---

Output voltage .....	0 - 100% of supply voltage
Output frequency .....	FC 301: 0.2 - 1000 Hz / FC 302: 0 - 1000 Hz
Switching on output .....	Unlimited
Ramp times .....	0.01 - 3600 sec.

### Torque characteristics:

---

Starting torque (Constant torque) .....	maximum 160% for 1 min.*
Starting torque .....	maximum 180% up to 0.5 sec.*
Overload torque (Constant torque) .....	maximum 160% for 1 min.*

*\*Percentage relates to FC 300's nominal torque.*

### Cable lengths and cross sections:

---

Max. motor cable length, screened/armoured .....	FC 301: 50 m / FC 302: 150 m
Max. motor cable length, unscreened/unarmoured .....	FC 301: 75 m / FC 302: 300 m
Max. cross section to motor, mains, load sharing and brake (see section Electrical Data in the FC 300 Design Guide MG.33.BX.YY for more information), (0.25 kW - 7.5 kW) .....	4 mm <sup>2</sup> / 10 AWG
Max. cross section to motor, mains, load sharing and brake (see section Electrical Data in the FC 300 Design Guide MG.33.BX.YY for more information), (11-15 kW) .....	16 mm <sup>2</sup> / 6 AWG
Max. cross section to motor, mains, load sharing and brake (see section Electrical Data in the FC 300 Design Guide MG.33.BX.YY for more information), (18.5-22 kW) .....	35 mm <sup>2</sup> / 2 AWG
Maximum cross section to control terminals, rigid wire .....	1.5 mm <sup>2</sup> /16 AWG (2 x 0.75 mm <sup>2</sup> )
Maximum cross section to control terminals, flexible cable .....	1 mm <sup>2</sup> /18 AWG
Maximum cross section to control terminals, cable with enclosed core .....	0.5 mm <sup>2</sup> /20 AWG
Minimum cross section to control terminals .....	0.25 mm <sup>2</sup>

## — FC 300 Selection —

## Digital inputs:

Programmable digital inputs .....	FC 301: 4 (5) / FC 302: 4 (6)
Terminal number .....	18, 19, 27 <sup>1)</sup> , 29 <sup>4)</sup> , 32, 33,
Logic .....	PNP or NPN
Voltage level .....	0 - 24 V DC
Voltage level, logic '0' PNP .....	< 5 V DC
Voltage level, logic '1' PNP .....	> 10 V DC
Voltage level, logic '0' NPN <sup>2)</sup> .....	> 19 V DC
Voltage level, logic '1' NPN <sup>2)</sup> .....	< 14 V DC
Maximum voltage on input .....	28 V DC
Input resistance, R <sub>i</sub> .....	approx. 4 kΩ

Safe stop Terminal 37<sup>4)</sup>:

Terminal 37 is fixed PNP logic

Voltage level .....	0 - 24 V DC
Voltage level, logic '0' PNP .....	< 4 V DC
Voltage level, logic '1' PNP .....	> 20 V DC
Nominal input current at 24 V .....	50 mA rms
Nominal input current at 20 V .....	60 mA rms
Input capacitance .....	400 nF

*All digital inputs are galvanically isolated from the supply voltage (PELV) and other high-voltage terminals.*

*1) Terminals 27 and 29 can also be programmed as output.*

*2) Except safe stop input Terminal 37.*

*3) Terminal 37 is only available in FC 302. It can only be used as safe stop input. Terminal 37 is suitable for category 3 installations according to EN 954-1 (safe stop according to category 0 EN 60204-1) as required by the EU Machinery Directive 98/37/EC. Terminal 37 and the Safe Stop function are designed in conformance with EN 60204-1, EN 50178, EN 61800-2, EN 61800-3, and EN 954-1. For correct and safe use of the Safe Stop function follow the related information and instructions in the Design Guide.*

*4) FC 302 only.*

— FC 300 Selection —

Analog inputs:

Number of analog inputs .....	2
Terminal number .....	53, 54
Modes .....	Voltage or current
Mode select .....	Switch S201 and switch S202
Voltage mode .....	Switch S201/switch S202 = OFF (U)
Voltage level .....	FC 301: 0 to + 10 / FC 302: -10 to +10 V (scaleable)
Input resistance, $R_i$ .....	approx. 10 k $\Omega$
Max. voltage .....	$\pm$ 20 V
Current mode .....	Switch S201/switch S202 = ON (I)
Current level .....	0/4 to 20 mA (scaleable)
Input resistance, $R_i$ .....	approx. 200 $\Omega$
Max. current .....	30 mA
Resolution for analog inputs .....	10 bit (+ sign)
Accuracy of analog inputs .....	Max. error 0.5% of full scale
Bandwidth .....	FC 301: 20 Hz / FC 302: 100 Hz

*The analog inputs are galvanically isolated from the supply voltage (PELV) and other high-voltage terminals.*

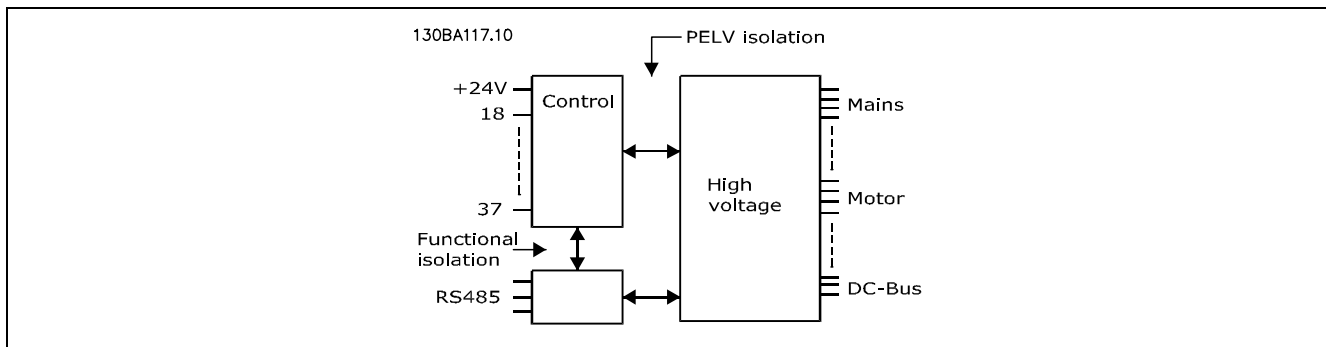

Pulse/encoder inputs:

Programmable pulse/encoder inputs .....	2/1
Terminal number pulse/encoder .....	29, 33 <sup>1)</sup> / 18, 32, 33 <sup>2)</sup>
Max. frequency at terminal 18, 29, 32, 33 .....	110 kHz (Push-pull driven)
Max. frequency at terminal 18, 29, 32, 33 .....	5 kHz (open collector)
Min. frequency at terminal 18, 29, 32, 33 .....	4 Hz
Voltage level .....	see section on Digital input
Maximum voltage on input .....	28 V DC
Input resistance, $R_i$ .....	approx. 4 k $\Omega$
Pulse input accuracy (0.1 - 1 kHz) .....	Max. error: 0.1% of full scale
Encoder input accuracy (1 - 110 kHz) .....	Max. error: 0.05 % of full scale

*The pulse and encoder inputs (terminals 18, 29, 32, 33) are galvanically isolated from the supply voltage (PELV) and other high-voltage terminals.*

- 1) Pulse inputs are 29 and 33
- 2) Encoder inputs: 32 = A, and 33 = B

## — FC 300 Selection —

## Analog output:

---

Number of programmable analog outputs .....	1
Terminal number .....	42
Current range at analog output .....	0/4 - 20 mA
Max. load to common at analog output .....	500 Ω
Accuracy on analog output .....	Max. error: 0.5 % of full scale
Resolution on analog output .....	12 bit

*The analog output is galvanically isolated from the supply voltage (PELV) and other high-voltage terminals.*

## Control card, RS 485 serial communication:

---

Terminal number .....	68 (P,TX+, RX+), 69 (N,TX-, RX-)
Terminal number 61 .....	Common for terminals 68 and 69

*The RS 485 serial communication circuit is functionally separated from other central circuits and galvanically isolated from the supplier voltage (PELV).*

## Digital output:

---

Programmable digital/pulse outputs .....	2
Terminal number .....	27, 29 <sup>1)</sup>
Voltage level at digital/frequency output .....	0 - 24 V
Max. output current (sink or source) .....	40 mA
Max. load at frequency output .....	1 kΩ
Max. capacitive load at frequency output .....	10 nF
Minimum output frequency at frequency output .....	0 Hz
Maximum output frequency at frequency output .....	32 kHz
Accuracy of frequency output .....	Max. error: 0.1 % of full scale
Resolution of frequency outputs .....	12 bit

*1) Terminal 27 and 29 can also be programmed as input.*

*The digital output is galvanically isolated from the supply voltage (PELV) and other high-voltage terminals.*

## Control card, 24 V DC output:

---

Terminal number .....	12, 13
Max. load .....	FC 301: 130 mA / FC 302: 200 mA

*The 24 V DC supply is galvanically isolated from the supply voltage (PELV), but has the same potential as the analog and digital inputs and outputs.*

## Relay outputs:

---

Programmable relay outputs .....	FC 301 ≤ 7.5 kW: 1 / FC 301 ≥ 11 kW: 2 / FC 302 all kW: 2
Relay 01 Terminal number .....	1-3 (break), 1-2 (make)
Max. terminal load (AC-1) <sup>1)</sup> on 1-3 (NC), 1-2 (NO) (Resistive load) .....	240 V AC, 2 A
Max. terminal load (AC-15) <sup>1)</sup> (Inductive load @ cosφ 0.4) .....	240 V AC, 0.2 A
Max. terminal load (DC-1) <sup>1)</sup> on 1-2 (NO), 1-3 (NC) (Resistive load) .....	60 V DC, 1A
Max. terminal load (DC-13) <sup>1)</sup> (Inductive load) .....	24 V DC, 0.1A
Relay 02 (FC 302 only) Terminal number .....	4-6 (break), 4-5 (make)
Max. terminal load (AC-1) <sup>1)</sup> on 4-5 (NO) (Resistive load) .....	400 V AC, 2 A
Max. terminal load (AC-15) <sup>1)</sup> on 4-5 (NO) (Inductive load @ cosφ 0.4) .....	240 V AC, 0.2 A
Max. terminal load (DC-1) <sup>1)</sup> on 4-5 (NO) (Resistive load) .....	80 V DC, 2 A
Max. terminal load (DC-13) <sup>1)</sup> on 4-5 (NO) (Inductive load) .....	24 V DC, 0.1A
Max. terminal load (AC-1) <sup>1)</sup> on 4-6 (NC) (Resistive load) .....	240 V AC, 2 A
Max. terminal load (AC-15) <sup>1)</sup> on 4-6 (NC) (Inductive load @ cosφ 0.4) .....	240 V AC, 0.2A
Max. terminal load (DC-1) <sup>1)</sup> on 4-6 (NC) (Resistive load) .....	50 V DC, 2 A
Max. terminal load (DC-13) <sup>1)</sup> on 4-6 (NC) (Inductive load) .....	24 V DC, 0.1 A
Min. terminal load on 1-3 (NC), 1-2 (NO), 4-6 (NC), 4-5 (NO) .....	24 V DC 10 mA, 24 V AC 20 mA

— FC 300 Selection —

Environment according to EN 60664-1 ..... overvoltage category III/pollution degree 2  
 1) IEC 60947 part 4 and 5

*The relay contacts are galvanically isolated from the rest of the circuit by reinforced isolation (PELV).*

Control card, 10 V DC output:

Terminal number ..... 50  
 Output voltage ..... 10.5 V ±0.5 V  
 Max. load ..... 15 mA

*The 10 V DC supply is galvanically isolated from the supply voltage (PELV) and other high-voltage terminals.*

Control characteristics:

Resolution of output frequency at 0 - 1000 Hz ..... FC 301: +/- 0.013 Hz / FC 302: +/- 0.003 Hz  
 Repeat accuracy of *Precise start/stop* (terminals 18, 19) ..... FC 301: ≤ ± 1ms / FC 302: ≤ ± 0.1 msec  
 System response time (terminals 18, 19, 27, 29, 32, 33) ..... FC 301: ≤ 10 ms / FC 302: ≤ 2 ms  
 Speed control range (open loop) ..... 1:100 of synchronous speed  
 Speed control range (closed loop) ..... 1:1000 of synchronous speed  
 Speed accuracy (open loop) ..... 30 - 4000 rpm: Maximum error of ±8 rpm  
 Speed accuracy (closed loop) ..... 0 - 6000 rpm: Maximum error of ±0.15 rpm

*All control characteristics are based on a 4-pole asynchronous motor*

Surroundings:

Enclosure ≤ 7.5 kW ..... IP 20, IP 55  
 Enclosure ≥ 11 kW ..... IP 21, IP 55  
 Enclosure kit available ≤ 7.5 kW ..... IP21/TYPE 1/IP 4X top  
 Vibration test ..... 1.0 g  
 Max. relative humidity ..... 5% - 95%(IEC 721-3-3; Class 3K3 (non-condensing) during operation  
 Aggressive environment (IEC 721-3-3), uncoated ..... class 3C2  
 Aggressive environment (IEC 721-3-3), coated ..... class 3C3  
 Ambient temperature ..... Max. 50 °C (24-hour average maximum 45 °C)  
*Derating for high ambient temperature, see section on special conditions*  
 Minimum ambient temperature during full-scale operation ..... 0 °C  
 Minimum ambient temperature at reduced performance ..... - 10 °C  
 Temperature during storage/transport ..... -25 - +65/70 °C  
 Maximum altitude above sea level ..... 1000 m  
*Derating for high altitude, see section on special conditions*

EMC standards, Emission ..... EN 61800-3, EN 61000-6-3/4, EN 55011  
 EMC standards, Immunity ..... EN 61800-3, EN 61000-6-1/2,  
 EN 61000-4-2, EN 61000-4-3, EN 61000-4-4, EN 61000-4-5, EN 61000-4-6

*See section on special conditions*

Control card performance:

Scan interval ..... FC 301: 5 ms / FC 302: 1 ms

Control card, USB serial communication:

USB standard ..... 1.1 (Full speed)  
 USB plug ..... USB type B "device" plug

*Connection to PC is carried out via a standard host/device USB cable.*

*The USB connection is galvanically isolated from the supply voltage (PELV) and other high-voltage terminals.*

*The USB connection is not galvanically isolated from protection earth. Use only isolated laptop as PC connection to the USB connector on FC 300 drive.*

## □ Efficiency

### Efficiency of FC 300 Series ( $\eta_{VLT}$ )

The load on the frequency converter has little effect on its efficiency. In general, the efficiency is the same at the rated motor frequency  $f_{M,N}$ , even if the motor supplies 100% of the rated shaft torque or only 75%, i.e. in case of part loads.

This also means that the efficiency of the frequency converter does not change even if other U/f characteristics are chosen.

However, the U/f characteristics influence the efficiency of the motor.

The efficiency declines a little when the switching frequency is set to a value of above 5 kHz. The efficiency will also be slightly reduced if the mains voltage is 500 V, or if the motor cable is longer than 30 m.

### Efficiency of the motor ( $\eta_{MOTOR}$ )

The efficiency of a motor connected to the frequency converter depends on magnetising level. In general, the efficiency is just as good as with mains operation. The efficiency of the motor depends on the type of motor.

In the range of 75-100% of the rated torque, the efficiency of the motor is practically constant, both when it is controlled by the frequency converter and when it runs directly on mains.

In small motors, the influence from the U/f characteristic on efficiency is marginal. However, in motors from 11 kW and up, the advantages are significant.

In general, the switching frequency does not affect the efficiency of small motors. Motors from 11 kW and up have their efficiency improved (1-2%). This is because the sine shape of the motor current is almost perfect at high switching frequency.

### Efficiency of the system ( $\eta_{SYSTEM}$ )

To calculate the system efficiency, the efficiency of FC 300 Series ( $\eta_{VLT}$ ) is multiplied by the efficiency of the motor ( $\eta_{MOTOR}$ ):

$$\eta_{SYSTEM} = \eta_{VLT} \times \eta_{MOTOR}$$

Calculate the efficiency of the system at different loads based on the graph above.

— FC 300 Selection —

□ **Acoustic Noise**

The acoustic noise from the frequency converter comes from three sources:

1. DC intermediate circuit coils.
2. Integral fan.
3. RFI filter choke.

The typical values measured at a distance of 1 m from the unit:

<b>FC 301/ FC 302</b>	
PK25-P7K5: @ 400 V	IP20/IP21/NEMA TYPE 1
PK25-P7K5	IP55/NEMA TYPE 12
Reduced fan speed	51 dB(A)
Full fan speed	60 dB(A)

□ **Peak Voltage on Motor**

When a transistor in the inverter bridge switches, the voltage across the motor increases by a  $dV/dt$  ratio depending on:

- the motor cable (type, cross-section, length screened or unscreened)
- inductance

The natural induction causes an overshoot  $U_{PEAK}$  in the motor voltage before it stabilises itself at a level depending on the voltage in the intermediate circuit. The rise time and the peak voltage  $U_{PEAK}$  affect the service life of the motor. If the peak voltage is too high, especially motors without phase coil insulation are affected. If the motor cable is short (a few metres), the rise time and peak voltage are lower.

If the motor cable is long (100 m), the rise time and peak voltage increases.

If very small motors are used without phase coil insulation, connect an LC filter to the frequency converter.



## □ Special Conditions

### □ Derating for Ambient Temperature - data valid for ≤ 7.5 kW

The ambient temperature ( $T_{AMB,MAX}$ ) is the maximum temperature allowed. The average ( $T_{AMB,AVG}$ ) measured over 24 hours must be at least 5 °C lower.

If the frequency converter is operated at temperatures above 50 °C, the continuous output current should be decreased according to following diagram:

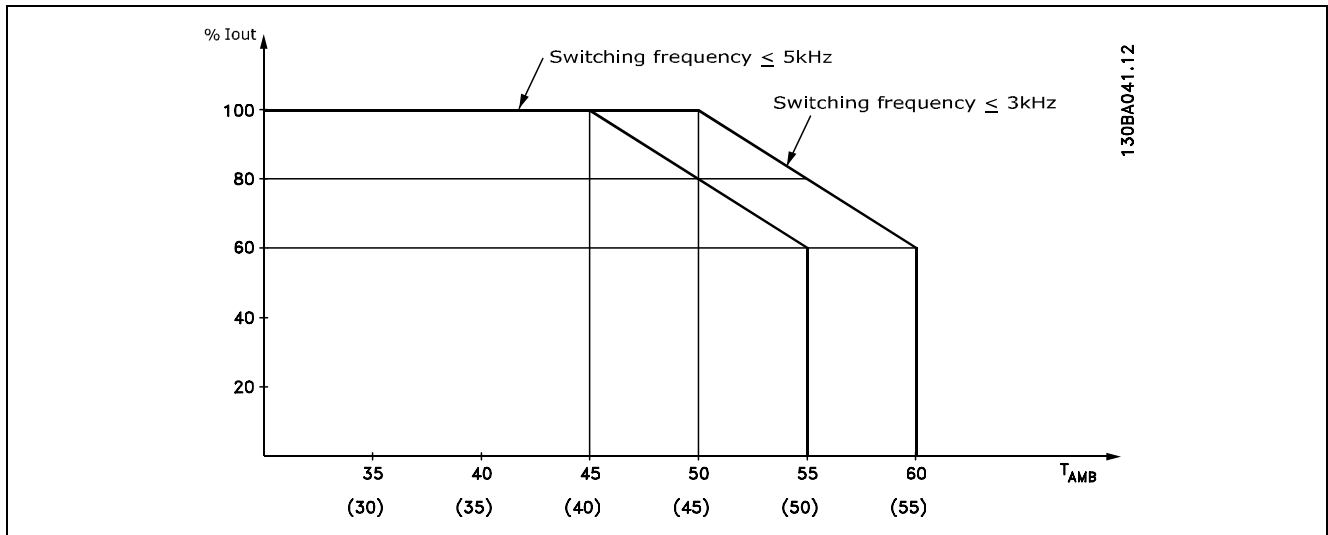

### □ Derating for Low Air Pressure

In case of lower air pressure the cooling capability of air is decreased.

Below 1000 m altitude no derating is necessary.

Above 1000 m the ambient temperature ( $T_{AMB}$ ) or max. output current ( $I_{VLT,MAX}$ ) should be derated in accordance with the shown diagram:

1. Derating of output current versus altitude at  $T_{AMB} = \text{max. } 50^{\circ}\text{C}$
2. Derating of max.  $T_{AMB}$  versus altitude at 100% output current.

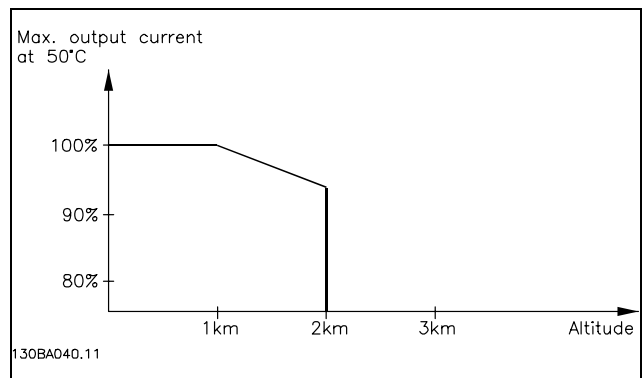

### □ Derating for Running at Low Speed

When a motor is connected to a frequency converter, it is necessary to check that the cooling of the motor is adequate.

At low RPM values, the motor fan is not able to supply the required volume of air for cooling. This problem occurs when the load torque is constant (e.g. a conveyor belt) across the regulating range. The reduced ventilation available determines the size of the torque that can be permitted under a continuous load.

If the motor is to run continuously at an RPM value lower than half the rated value, the motor must be supplied with additional air for cooling (or use a motor designed for this type of operation).

Instead of such extra cooling, the load level of the motor can be reduced e.g. by choosing a bigger motor. However, the design of the frequency converter sets a limit to the motor size.

— FC 300 Selection —

□ **Derating for Installing Long Motor Cables or Cables with Larger Cross-Section**

The max. cable length for FC 301 is 150 m unscreened cable and 50 m screened cable, respective for FC 302 is 300 m unscreened and 150 m screened cable.

The frequency converter has been tested using 300 m unscreened cable and 150 m screened cable.

The frequency converter has been designed to work using a motor cable with a rated cross-section. If a cable with a larger cross-section is used, reduce the output current by 5% for every step the cross-section is increased.

(Increased cable cross-section leads to increased capacity to earth, and thus an increased earth leakage current).

□ **Temperature-Dependent Switch Frequency**

This function ensures the highest possible switch frequency without causing a thermal overload of the frequency converter. The internal temperature indicates whether the switch frequency can be based on the load, the ambient temperature, the supply voltage, or the cable length.

The switch frequency is set in par. 14-01.

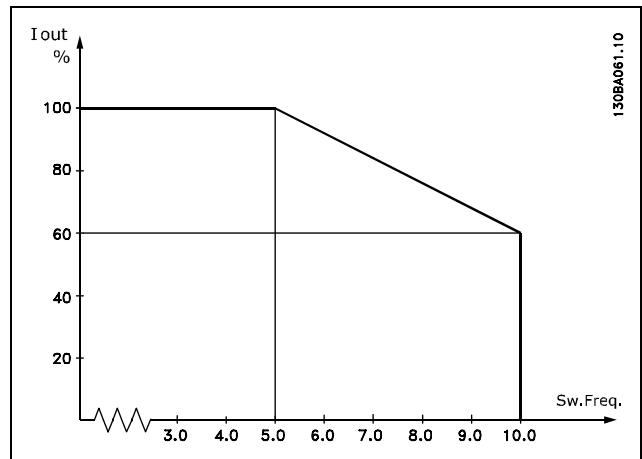

□ **Mechanical Dimension**

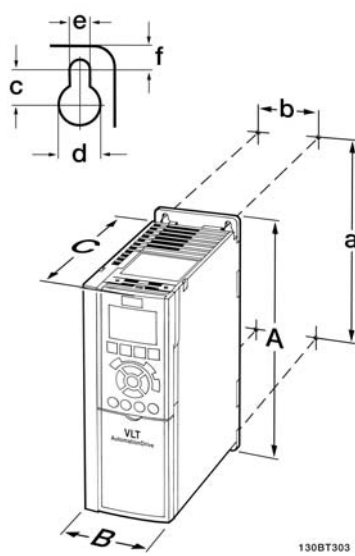

FC 300 IP20 - see table for mechanical dimensions  
A2 + A3 (IP20)

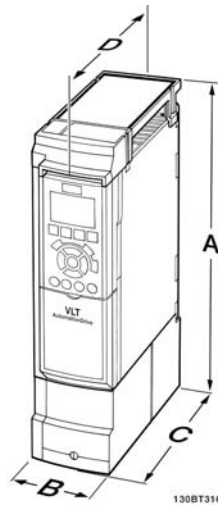

Mechanical dimensions of the IP 21/IP 4x/ TYPE 1 enclosure kit ( $\leq 7.5$  kW)  
A2 + A3 (IP21)

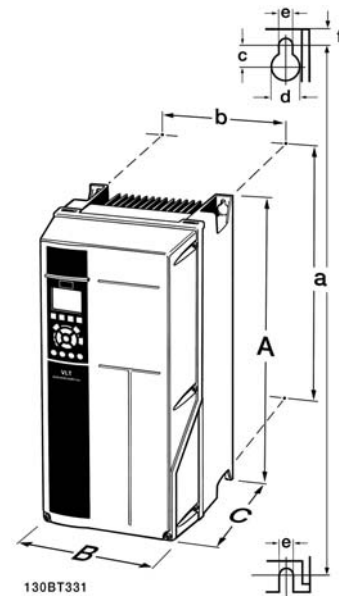

Mechanical dimensions of the IP 21/IP 4x/ TYPE 1/IP55/TYP 12 (11-22 kW)  
A5 + B1 + B2

Mechanical dimensions								
		Frame size A2 0.25-2.2 kW (200-240 V) 0.37-4.0 kW (380-500 V)		Frame size A3 3.0-3.7 kW (200-240 V) 5.5-7.5 kW (380-500 V) 0.75-7.5 kW (525-600 V)		Frame size A5 0.25-3.7 kW (200-500 V) 0.37-7.5 kW (380-500 V)	Frame size B1 11-15 kW (380-500 V)	Frame size B2 18.5-22 kW (380-500 V)
		IP20	IP21/Type 1	IP20	IP21/Type 1	IP55	IP21	IP21
<b>Height</b>								
Height of back plate	A	268 mm	375 mm	268 mm	375 mm	420 mm	480 mm	650 mm
Distance between mounting holes	a	257 mm	350 mm	257 mm	350 mm	402 mm	454 mm	624 mm
<b>Width</b>								
Width of back plate	B	90 mm	90 mm	130 mm	130 mm	242 mm	242 mm	242 mm
Distance between mounting holes	b	70 mm	70 mm	110 mm	110 mm	215 mm	210 mm	210 mm
<b>Depth</b>								
Depth without option A/B	C	205 mm	205 mm	205 mm	205 mm	195 mm	260 mm	260 mm
With option A/B	C	220 mm	220 mm	220 mm	220 mm	195 mm	260 mm	260 mm
Without option A/B	D		207 mm		207 mm			
With option A/B	D		222 mm		222 mm			
<b>Screw holes</b>								
	c	8.0 mm	8.0 mm	8.0 mm	8.0 mm	8.25 mm	12 mm	12 mm
	d	ø11 mm	ø11 mm	ø11 mm	ø11 mm	ø12 mm	ø19 mm	ø19 mm
	e	ø5.5 mm	ø5.5 mm	ø5.5 mm	ø5.5 mm	ø6.5 mm	ø9 mm	ø9 mm
	f	9 mm	9 mm	9 mm	9 mm	9 mm	9 mm	9 mm
<b>Max weight</b>								
		4.9 kg	5.3 kg	6.6 kg	7.0 kg		23 kg	27 kg

## Options and Accessories

Danfoss offers a wide range of options and accessories for VLT AutomationDrive FC 300 Series.

### Mounting of Option Modules in Slot B

The power to the frequency converter must be disconnected.

- Remove the LCP (Local Control Panel), the terminal cover, and the LCP frame from the frequency converter.
- Fit the MCB10x option card into slot B.
- Connect the control cables and relieve the cable by the enclosed cable strips.  
\* Remove the knock out in the extended LCP frame, so that the option will fit under the extended LCP frame.
- Fit the extended LCP frame and terminal cover.
- Fit the LCP or blind cover in the extended LCP frame.
- Connect power to the frequency converter.
- Set up the input/output functions in the corresponding parameters, as mentioned in the section *General Technical Data*.

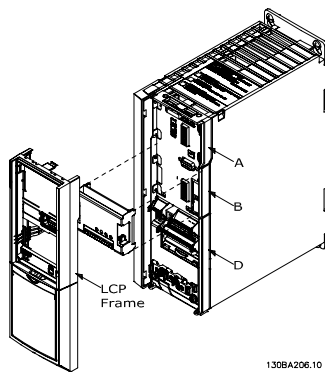

0.25 - 7.5 kW IP20

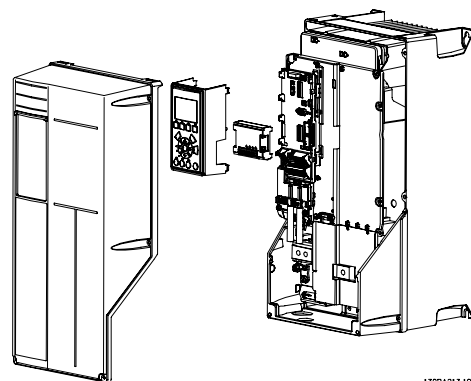

0.25 - 7.5 kW IP 55  
and  
11 - 22 kW IP21

### General Purpose Input Output Module MCB 101

MCB 101 is used for extension of digital and analog inputs and outputs of FC 301 and FC 302 AutomationDrive.

Contents: MCB 101 must be fitted into slot B in the AutomationDrive.

- MCB 101 option module
- Extended fixture for LCP
- Terminal cover

130BA208.10		MCB 101 General Purpose I/O						FC Series B slot				
SW. ver. XX.XX								Code No. 130BXXXX				
COM	DIN7	DIN8	DIN9	GND(1)	DOU3	DOU4	AOUT2	24V	GND(2)	AIN3	AIN4	
X30/	1	2	3	4	5	6	7	8	9	10	11	12

— FC 300 Selection —

□ **Galvanic Isolation In The MCB 101**

Digital/analog inputs are galvanically isolated from other inputs/outputs on the MCB 101 and in the control card of the drive. Digital/analog outputs in the MCB 101 are galvanically isolated from other inputs/outputs on the MCB 101, but not from these on the control card of the drive.

If the digital inputs 7, 8 or 9 are to be switched by use of the internal 24 V power supply (terminal 9) the connection between terminal 1 and 5 which is illustrated in the drawing has to be established.

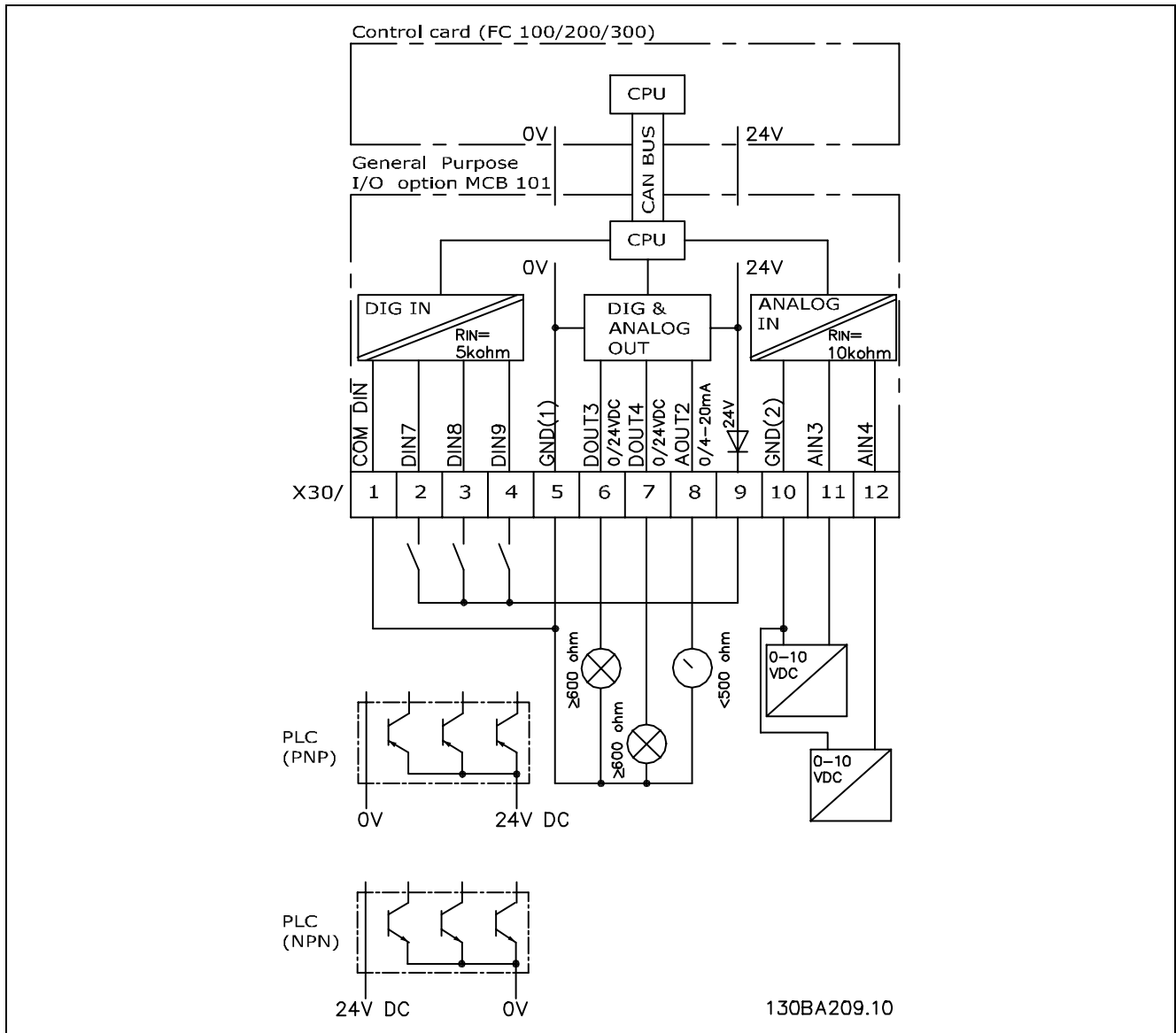

Principle Diagram

— FC 300 Selection —

□ **Digital inputs - Terminal X30/1-4**

Parameters for set-up: 5-16, 5-17 and 5-18

Number of digital inputs	Voltage level	Voltage levels	Input impedance	Max. load
3	0-24 V DC	PNP type: Common = 0 V Logic "0": Input < 5 V DC Logic "1": Input > 10 V DC NPN type: Common = 24 V Logic "0": Input > 19 V DC Logic "1": Input < 14 V DC	Approx. 5 k ohm	± 28 V continuous ± 37 V in minimum 10 sec.

□ **Encoder Option MCB 102**

The encoder module is used for interfacing feedback from motor or process. Parameter settings in group 17-xx

Used for:

- VVC plus closed loop
- Flux Vector Speed control
- Flux Vector Torque control
- Permanent magnet motor with SinCos feedback (Hiperface®)

Incremental encoder: 5 V TTL type

SinCos Encoder: Stegmann/SICK (Hiperface®)

Selection of parameters in par. 17-1\* and par. 1-02

When the encoder option kit is ordered separately the kit includes:

- Encoder module MCB 102
- Enlarged LCP fixture and enlarged terminal cover

The encoder option does not support FC 302 frequency converters manufactured before week 50/2004.

Min. software version: 2.03 (par. 15-43)

Connector Designation	Incremental Encoder (please refer to Graphic A)	SinCos Encoder Hiperface® (please refer to Graphic B)	SinCos Encoder EnDat	Description
X31				
1	NC			24 V Output
2	NC	8 Vcc		8 V Output
3	5 VCC		5 Vcc	5 V Output
4	GND		GND	GND
5	A input	+COS	+COS	A input
6	A inv input	REFCOS	REFCOS	A inv input
7	B input	+SIN	+SIN	B input
8	B inv input	REFSIN	REFSIN	B inv input
9	Z input	+Data RS485	Clock out	Z input OR +Data RS485
10	Z inv input	-Data RS485	Clock in	Z input OR -Data RS485
11	NC	NC	Data+	Future use
12	NC	NC	Data-	Future use

Max. 5V on X31.5-12

— FC 300 Selection —

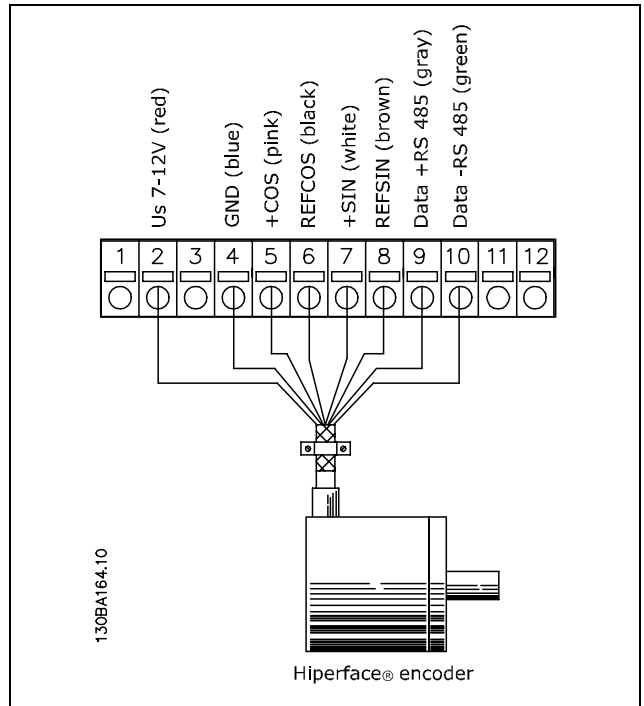
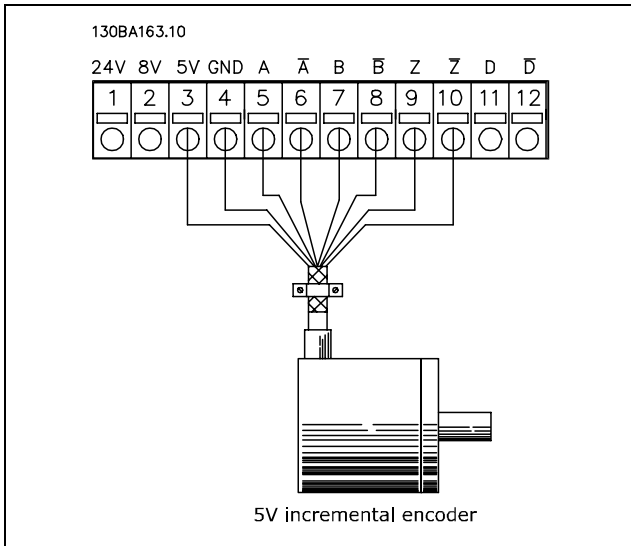

— FC 300 Selection —

□ **Resolver Option MCB 103**

MCB 103 Resolver option is used for interfacing resolver motor feedback to FC 300 AutomationDrive. Resolvers are used basically as motor feedback device for Permanent Magnet brushless synchronous motors. When the Resolver option is ordered separately the kit includes:

- Resolver option MCB 103
- Enlarged LCP fixture and enlarged terminal cover

Selection of parameters: 17-5x resolver Interface.

The resolver interface must support one resolver with the following specifications:

**Resolver specifications:**

MCB 103 Resolver Option supports a various number of resolver types.

Number of poles on resolver	Par 17-50: 2 or 4 *2
Resolver input voltage	Par 17-51: 2.0 – 8.0 V *7.0V
Carrier frequency (Ref. voltage)	Par 17-52: 2.5 – 15 kHz *10.0 kHz
Transformation ratio	Par 17-53: 0.1 – 1.1 *0.5
Primary voltage	2-8 Vrms
Primary frequency	2 kHz - 15 kHz
Primary current	Max. 50 mArms
Secondary input voltage	Max 8 Vrms
Resolution	10 bit @ max input amplitude
Secondary load	App. 10 kΩ
Cable length	Up to 150 m

*Note: Cables MUST be shielded and separated from the motor cables.*

**LED indicators**

LED 1 is on when the reference signal is OK to resolver  
 LED 2 is on when Cosinus signal is OK from resolver  
 LED 3 is on when Sinus signal is OK from resolver

The LEDs are active when par. 17-61 is set to *Warning* or *Trip*.

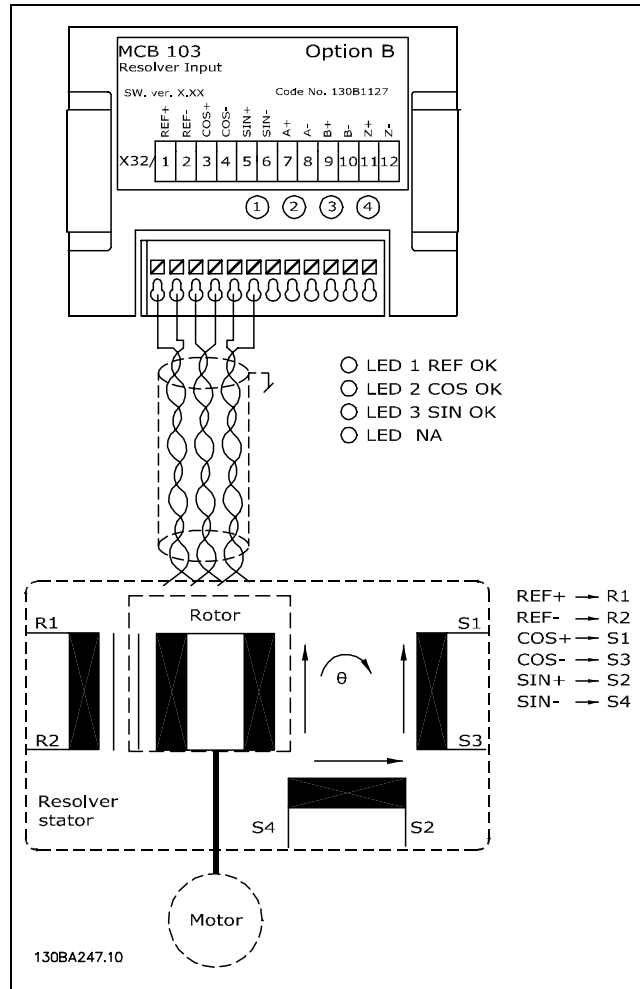



— FC 300 Selection —

**Set-up example**

In this example a Permanent Magnet (PM) Motor is used with resolver as speed feedback. A PM motor must usually operate in flux mode.

**Wiring:**

The max cable length is 150 m when a twisted pair type of cable is used.



**NB!:**

The screen of the resolver cable must be correct connected to the de-coupling plate and connected to chassis (earth) on the motor side.



**NB!:**

Always use screened motor cables and brake chopper cables.

<b>Adjust following parameters:</b>		
Par. 1-00	Configuration Mode	Speed closed loop [1]
Par. 1-01	Motor Control Principle	Flux with feedback [3]
Par. 1-10	Motor Construction	PM, non salient SPM [1]
Par. 1-24	Motor Current	Nameplate
Par. 1-25	Motor Nominal Speed	Nameplate
Par. 1-26	Motor Cont. Rated Torque	Nameplate
AMA is not possible on PM motors		
Par. 1-30	Stator Resistance	Motor data sheet
Par. 1-37	d-axis Inductance (Ld)	Motor data sheet (mH)
Par. 1-39	Motor Poles	Motor data sheet
Par. 1-40	Back EMF at 1000 RPM	Motor data sheet
Par. 1-41	Motor Angle Offset	Motor data sheet (Usually zero)
Par. 17-50	Poles	Resolver data sheet
Par. 17-51	Input Voltage	Resolver data sheet
Par. 17-52	Input Frequency	Resolver data sheet
Par. 17-53	Transformation Ratio	Resolver data sheet
Par. 17-60	Feedback Direction	
Par. 17-61	Feedback Signal Monitoring	Hardware check of resolver connections

— FC 300 Selection —

□ **Relay Option MCB 105**

The MCB 105 option includes 3 pieces of SPDT contacts and must be fitted into option slot B.

Electrical Data:

Max terminal load (AC-1) <sup>1)</sup> (Resistive load)	240 V AC 2A
Max terminal load (AC-15) <sup>1)</sup> (Inductive load @ cosφ 0.4)	240 V AC 0.2 A
Max terminal load (DC-1) <sup>1)</sup> (Resistive load)	24 V DC 1 A
Max terminal load (DC-13) <sup>1)</sup> (Inductive load)	24 V DC 0.1 A
Min terminal load (DC)	5 V 10 mA
Max switching rate at rated load/min load	6 min <sup>-1</sup> /20 sec <sup>-1</sup>

1) IEC 947 part 4 and 5

When the relay option kit is ordered separately the kit includes:

- Relay Module MCB 105
- Enlarged LCP fixture and enlarged terminal cover
- Label for covering access to switches S201, S202 and S801
- Cable strips for fastening cables to relay module

The relay option does not support FC 302 frequency converters manufactured before week 50/2004.  
Min. software version: 2.03 (par. 15-43).

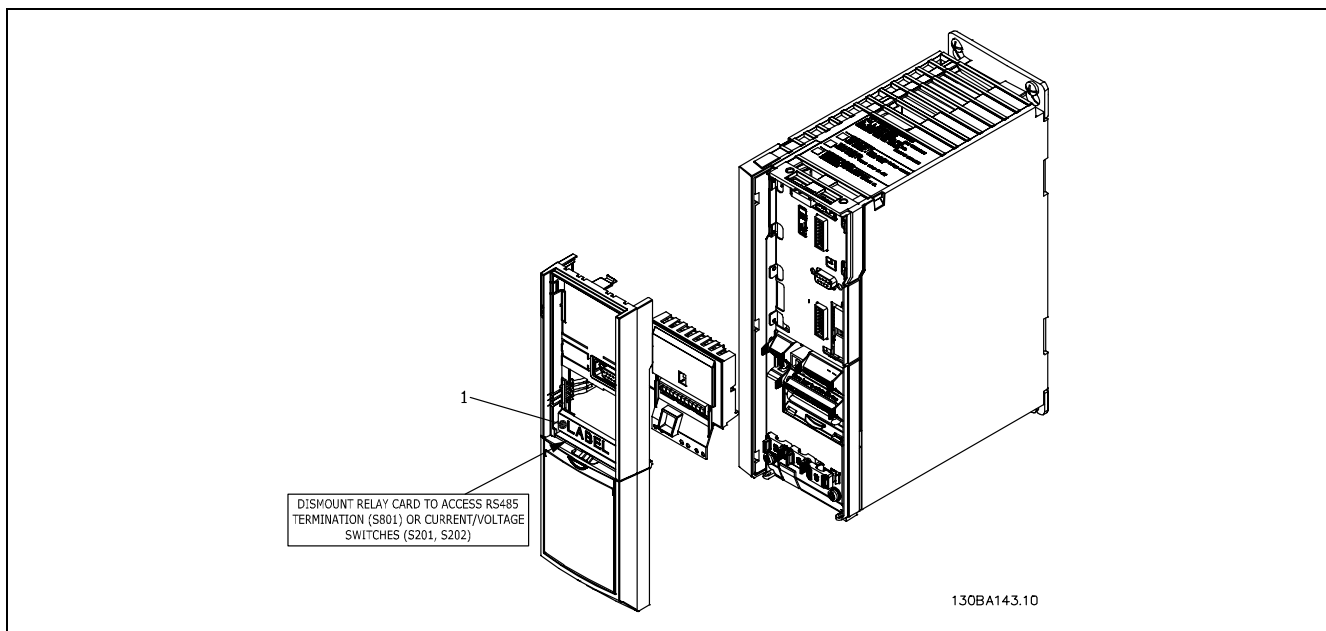

≤ 7.5 kW

**IMPORTANT**

1. The label **MUST** be placed on the LCP frame as shown (UL approved).

— FC 300 Selection —

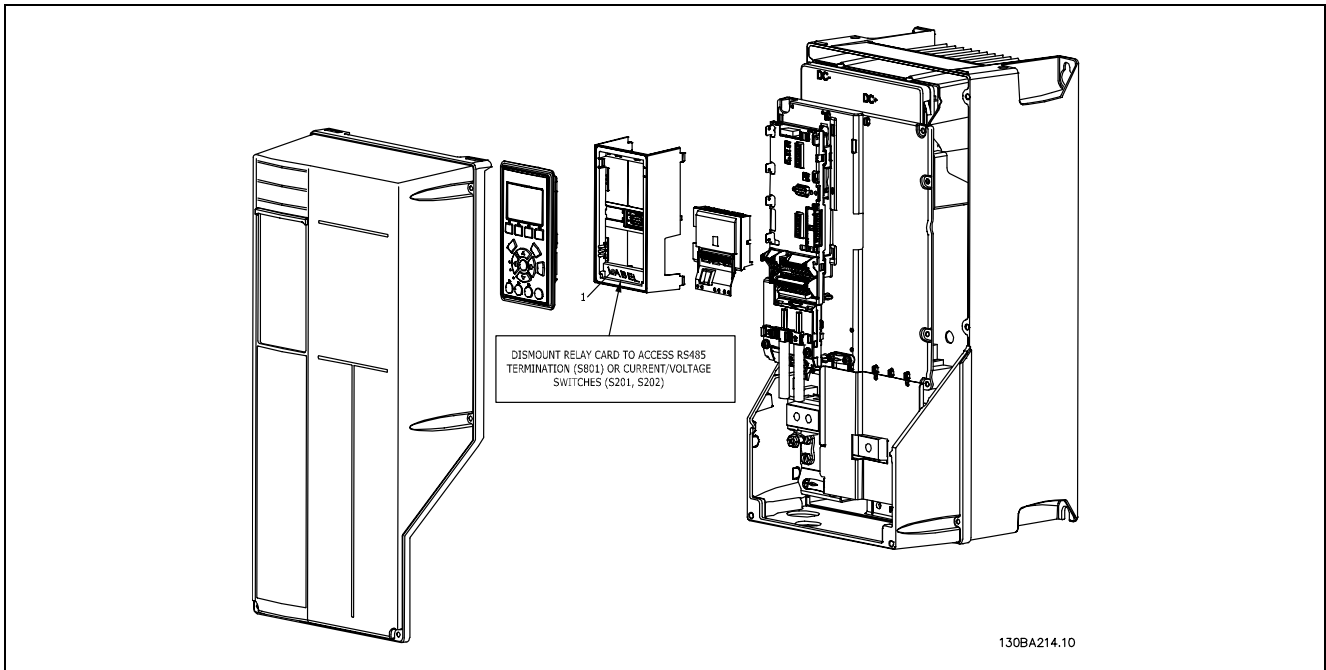

11-22 kW

**IMPORTANT**

1. The label MUST be placed on the LCP frame as shown (UL approved).



Warning Dual supply

How to add the MCB 105 option:

- The power to the frequency converter must be disconnected.
- The power to the live part connections on relay terminals must be disconnected.
- Remove the LCP, the terminal cover and the LCP fixture from the FC 30x.
- Fit the MCB 105 option in slot B.
- Connect the control cables and fasten the cables with the enclosed cable strips.
- Make sure the length of the stripped wire is correct (see the following drawing).
- Do not mix live parts (high voltage) with control signals (PELV).
- Fit the enlarged LCP fixture and enlarged terminal cover.
- Replace the LCP.
- Connect power to the frequency converter.
- Select the relay functions in par. 5-40 [6-8], 5-41 [6-8] and 5-42 [6-8].

NB (Array [6] is relay 7, array [7] is relay 8, and array [8] is relay 9)

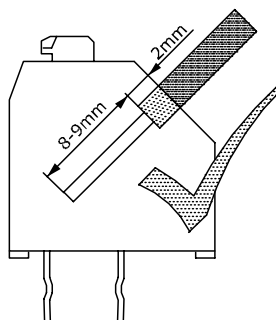
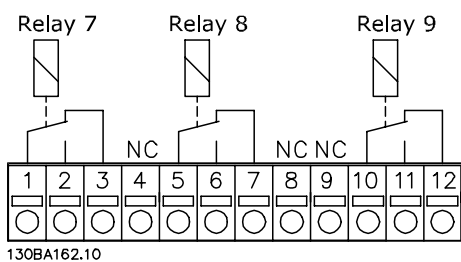

130BA177.10

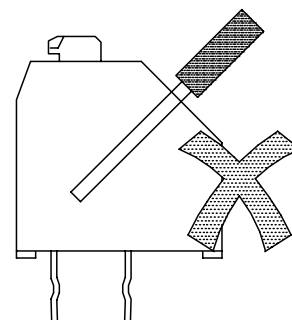

— FC 300 Selection —

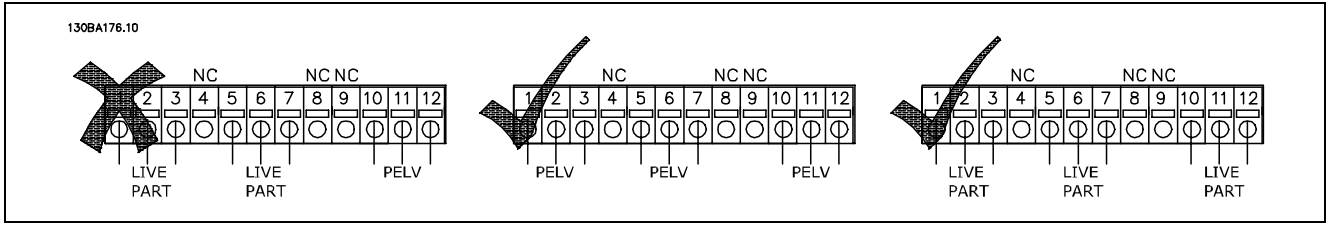

Do not combine low voltage parts and PELV systems.

— FC 300 Selection —

□ **24 V Back-Up Option MCB 107 (Option D)**

External 24 V DC Supply

An external 24 V DC supply can be installed for low-voltage supply to the control card and any option card installed. This enables full operation of the LCP (including the parameter setting) without connection to mains.

External 24 V DC supply specification:

Input voltage range .....	24 V DC $\pm$ 15 % (max. 37 V in 10 s)
Max. input current .....	2.2 A
Average input current for FC 302 .....	0.9 A
Max cable length .....	75 m
Input capacitance load .....	< 10 $\mu$ F
Power-up delay .....	< 0.6 s

The inputs are protected.

Terminal numbers:

- Terminal 35: - external 24 V DC supply.
- Terminal 36: + external 24 V DC supply.

Follow these steps:

1. Remove the LCP or Blind Cover
2. Remove the Terminal Cover
3. Remove the Cable Decoupling Plate and the plastic cover underneath
4. Insert the 24 V DC Back-up External Supply Option in the Option Slot
5. Mount the Cable Decoupling Plate
6. Attach the Terminal Cover and the LCP or Blind Cover.

When MCB 107, 24 V back-up option is supplying the control circuit, the internal 24 V supply is automatically disconnected.

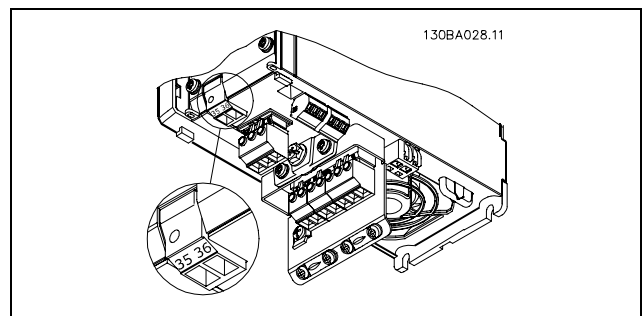

Connection to 24 V back-up supplier ( $\leq$  7.5 kW).

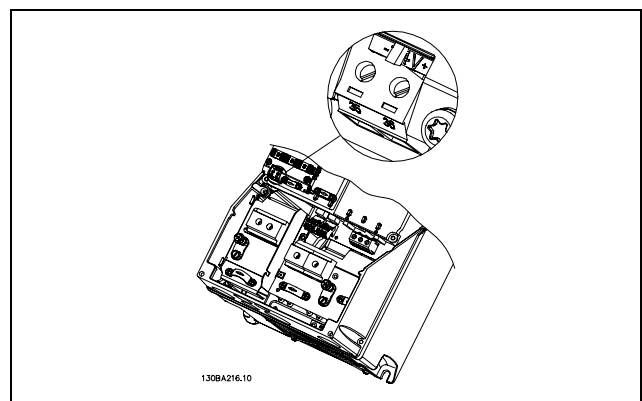

Connection to 24 V back-up supplier (11-22 kW).

□ **Brake Resistors**

Brake resistors are used in applications where high dynamics are needed or a high inertia load has to be stopped. The brake resistor is used to remove the energy from the DC link in the frequency converter.

Code numbers for brake resistors: See section *How to Order*.

□ **Remote mounting Kit for LCP**

The Local Control Panel can be moved to the front of a cabinet by using the remote build in kit. The enclosure is the IP65. The fastening screws must be tightened with a torque of max. 1 Nm.

Technical data	
Enclosure:	IP 65 front
Max. cable length between VLT and unit:	3 m
Communication std:	RS 485

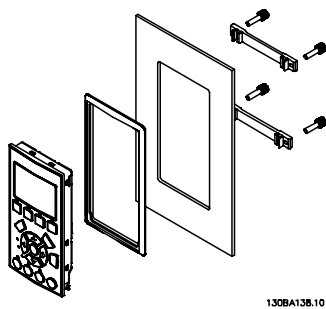

130BA138.10

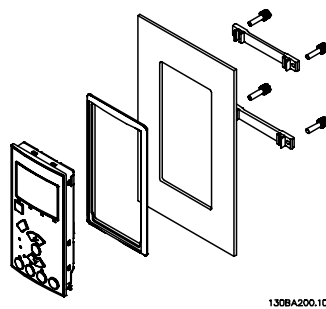

130BA200.10

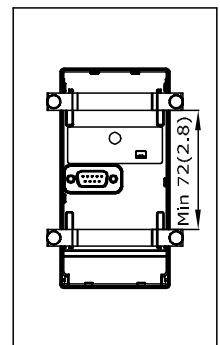
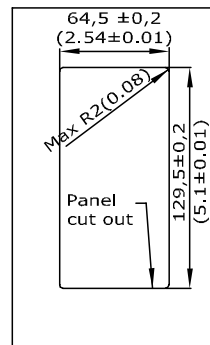

130BA139.11

□ **IP 21/IP 4X/ TYPE 1 Enclosure Kit**

IP 20/IP 4X top/ TYPE 1 is an optional enclosure element available for IP 20 Compact units. If the enclosure kit is used, an IP 20 unit is upgraded to comply with enclosure IP 21/ 4X top/TYPE 1.

The IP 4X top can be applied to all standard IP 20 FC 30X variants.

□ **IP 21/Type 1 Enclosure Kit**

- A – Top cover
- B – Brim
- C – Base part
- D – Base cover
- E – Screw(s)

Place the top cover as shown. If an A or B option is used the brim must be fitted to cover the top inlet. Place the base part C at the bottom of the drive and use the clamps from the accessory bag to correctly fasten the cables. Holes for cable glands:

Size A2: 2x PG16 (1/2") 3xPG21 (3/4")

Size A3: 3xPG16 (1/2") 3xPG21 (3/4")

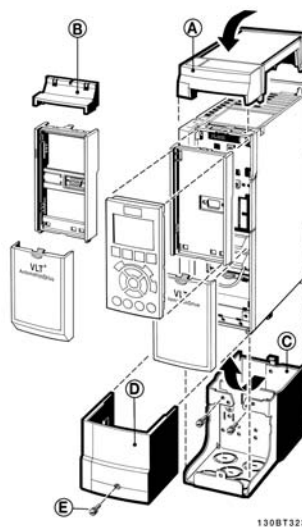

130BT323

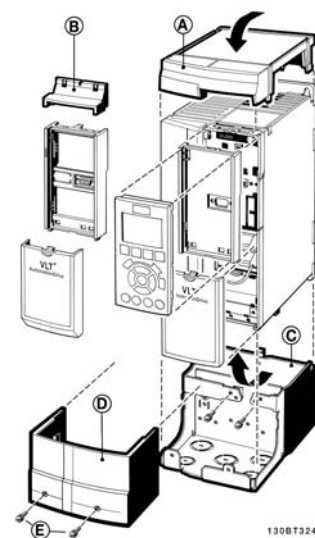

130BT324

## — FC 300 Selection —

□ **LC Filters**

When a motor is controlled by a frequency converter, resonance noise will be heard from the motor. This noise, which is the result of the design of the motor, arises every time an inverter switch in the frequency converter is activated. The frequency of the resonance noise thus corresponds to the switching frequency of the frequency converter.

For the FC 300 Series, Danfoss can supply an LC filter to dampen the acoustic motor noise.

The filter reduces the ramp-up time of the voltage, the peak load voltage  $U_{PEAK}$  and the ripple current  $\Delta I$  to the motor, which means that current and voltage become almost sinusoidal. Consequently, the acoustic motor noise is reduced to a minimum.

The ripple current in the LC Filter coils, will also cause some noise. Solve the problem by integrating the filter in a cabinet or similar.





# How to Order

**Drive Configurator**

It is possible to design an FC 300 frequency converter according to the application requirements by using the ordering number system.

For the FC 300 Series, you can order standard drives and drives with integral options by sending a type code string describing the product to the local Danfoss sales office, i.e.:

FC-302PK75T5E20H1BGCXXXSXXXXA0BXCXXXD0

The meaning of the characters in the string can be located in the pages containing the ordering numbers in the chapter *How to Select Your VLT*. In the example above, a Profibus DP V1 and a 24 V back-up option is included in the drive.

Ordering numbers for FC 300 standard variants can also be located in the chapter *How to Select Your VLT*.

From the Internet based Drive Configurator, you can configure the right drive for the right application and generate the type code string. The Drive Configurator will automatically generate an eight-digit sales number to be delivered to your local sales office.

Furthermore, you can establish a project list with several products and send it to a Danfoss sales representative.

The Drive Configurator can be found on the global Internet site: [www.danfoss.com/drives](http://www.danfoss.com/drives).

**Ordering Form Type Code**

1	2	3	4	5	6	7	8	9	10	11	12	13	14	15	16	17	18	19	20	21	22	23	24	25	26	27	28	29	30	31	32	33	34	35	36	37	38	39	
FC-30					P			T	E		H											X	X	S	X	X	X	A		B		C							D
130BA052.12																																							

Product groups	1-3	▼
VLT series	4-6	▼
Power rating	8-10	▼
Dedicated Application	7	▼
Phases	11	▼
Mains Voltage	12	▼
Enclosure	14-15	▼
<b>Enclosure type</b>		▼
<b>Enclosure class</b>		▼
<b>Control supply voltage</b>		▼
<b>Hardware configuration</b>		▼
RFI filter	16-17	▼
Brake	18	▼

Display (LCP)	19	▼
Coating PCB	20	▼
Mains option	21	▼
Adaptation A	22	▼
Adaptation B	23	▼
Software release	24-27	▼
Software language	28	▼
A options	29-30	▼
B options	31-32	▼
C0 options, MCO	33-34	▼
<b>C1 options</b>	35	▼
<b>C option software</b>	36-37	▼
D options	38-39	▼

— How to Order —

Description	Pos	Possible choice
Product group	1-3	FC 30x
Drive series	4-6	FC 301 FC 302
Power rating	8-10	0.25-22 kW
Dedicated application		
Phases	11	Three phases (T)
Mains voltage	11-12	T 2: 200-240 V AC T 4: 380-480 V AC T 5: 380-500 V AC T 6: 525-600 V AC
Enclosure	14-15	E20: IP20 E21: IP 21/NEMA Type 1 E55: IP 55/NEMA Type 12 Z20: IP 20 No C and D options Z21: IP 21 No C and D options
RFI filter	16-17	H1: RFI filter class A1/B1 H2: No RFI filter, observes class A2
Brake	18	B: Brake chopper included X: No brake chopper included T: Safe Stop No brake (FC 301 in Z enclosure only) U: Safe stop brake chopper (FC 301 in Z enclosure only)
Display	19	G: Graphical Local Control Panel (LCP) N: Numerical Local Control Panel (LCP) X: No Local Control Panel
Coating PCB	20	C: Coated PCB X. No coated PCB
Mains option	21	X: No mains option 1: Mains disconnect
Adaptation	22	Reserved
Adaptation	23	Reserved
Software release	24-27	Actual software
Software language	28	
A options	29-30	A0: MCA 101 Profibus DP V1 A4: MCA 104 DeviceNet A6: MCA 105 CANOpen AX: No fieldbus

B options	31-32	BX: No option BK: MCB 101 General purpose I/O option BR: MCB 102 Encoder option BU: MCB 103 Resolver option BP: MCB 105 Relay option BZ: MCB 108 Safety PLC Interface
C0 options MCO	33-34	
C1 options	35	
C option software	36-37	
D options	38-39	DX: No option D0: DC back-up

## □ Ordering Numbers

### □ Ordering Numbers: Options and Accessories

Type	Description	Ordering no.	
<b>Miscellaneous hardware</b>			
DC link connector	Terminal block for DC link connection on frame size A2/A3	130B1064	
IP 21/4X top/TYPE 1 kit	Enclosure, frame size A2: IP21/IP 4X Top/TYPE 1	130B1122	
IP 21/4X top/TYPE 1 kit	Enclosure, frame size A3: IP21/IP 4X Top/TYPE 1	130B1123	
Profibus D-Sub 9	Connector kit for IP20	130B1112	
Profibus top entry kit	Top entry kit for Profibus connection	130B0524 <sup>1)</sup>	
Terminal blocks	Screw terminal blocks for replacing spring loaded terminals 1 pc 10 pin 1 pc 6 pin and 1 pc 3 pin connectors	130B1116	
<b>LCP</b>			
LCP 101	Numerical Local Control Panel (NLCP)	130B1124	
LCP 102	Graphical Local Control Panel (GLCP)	130B1107	
LCP cable	Separate LCP cable, 3 m	175Z0929	
LCP kit	Panel mounting kit including graphical LCP, fasteners, 3 m cable and gasket	130B1113	
LCP kit	Panel mounting kit including numerical LCP, fasteners and gasket	130B1114	
LCP kit	Panel mounting kit for all LCPs including fasteners, 3 m cable and gasket	130B1117	
<b>Options for Slot A Uncoated / Coated</b>		<b>Uncoated</b>	<b>Coated</b>
MCA 101	Profibus option DP V0/V1	130B1100	130B1200
MCA 104	DeviceNet option	130B1102	130B1202
MCA 105	CANopen	130B1103	
<b>Options for Slot B</b>			
MCB 101	General purpose Input Output option	130B1125	
MCB 102	Encoder option	130B1115	
MCB 103	Resolver option	130B1127	130B1227
MCB 105	Relay option	130B1110	
MCB 108	Safety PLC interface (DC/DC Converter)	130B1120	
<b>Option for Slot D</b>			
MCB 107	24 V DC back-up	130B1108	130B1208
<b>External Options</b>			
Ethernet IP	Ethernet master	175N2584	
<b>Spare Parts</b>			
Control board FC 302	Coated version	130B1109	
Control board FC 301	Coated version	130B1126	
Fan A2	Fan, frame size A2	130B1009	
Fan A3	Fan, frame size A3	130B1010	
Accessory bag B	Accessory bag, frame size A2	130B0509	
Accessory bag C	Accessory bag, frame size A3	130B0510	

1) Only IP21 / > 11 kW

Options can be ordered as factory built-in options, see ordering information. For information on fieldbus and application option compatibility with older software versions, please contact your Danfoss supplier.

**Ordering Numbers: Brake Resistors**

**Mains 200-240 V**

FC 301/302															
Selected resistor															
Standard IP 20										Aluminium Housed (Flatpack) IP65			Max. torque load <sup>b</sup>		
FC 301/ FC 302	P <sub>motor</sub>	R <sub>min</sub>	Duty Cycle 10%				Duty Cycle 40%				R <sub>rec</sub> per item	Duty cycle	Order no.	FC 301	FC 302
			R <sub>br,nom</sub> <sup>c</sup>	R <sub>rec</sub>	P <sub>br max</sub>	Order no.	R <sub>rec</sub>	P <sub>br max</sub>	Order no.	Order no.					
	[kW]	[Ω]	[Ω]	[Ω]	[kW]	175Uxxxx	[Ω]	[kW]	175Uxxxx	[Ω]	%	175Uxxxx			
PK25	0.25	420	466.7	425	0.095	1841	425	0.430	1941	430Ω/100W	8	1002	145%	160%	
PK37	0.37	284	315.3	310	0.250	1842	310	0.800	1942	310Ω/200W	16	0984	145%	160%	
PK55	0.55	190	211.0	210	0.285	1843	210	1.350	1943	210Ω/200W	9	0987	145%	160%	
PK75	0.75	139	154.0	145	0.065	1820	145	0.260	1920	150Ω/100W	14	1005	145%	160%	
PK75	0.75	139	154.0	-	-	-	-	-	-	150Ω/200W	40	0989	145%	160%	
P1K1	1.1	90	104.4	90	0.095	1821	90	0.430	1921	100Ω/100W	8	1006	145%	160%	
P1K1	1.1	90	104.4	-	-	-	-	-	-	100Ω/200W	20	0991	145%	160%	
P1K5	1.5	68	75.7	65	0.250	1822	65	0.800	1922	75Ω/200W	16	0992	145%	160%	
P2K2	2.2	46	51.0	50	0.285	1823	50	1.00	1923	50Ω/200W	9	0993	145%	160%	
P3K0	3	33	37.0	35	0.430	1824	35	1.35	1924	35Ω/200W	5.5	0994	145%	160%	
P3K0	3	33	37.0	-	-	-	-	-	-	72Ω/200W	12	2X0992 <sup>a</sup>	145%	160%	
P3K7	3.7	25	29.6	25	0.800	1825	25	3.00	1925	27Ω/200W	4	0995	145%	160%	

<sup>a</sup> Order two pieces, resistors must be connected in parallel.

<sup>b</sup> Max. load with the resistor in Danfoss standard program.

<sup>c</sup> R<sub>br,nom</sub> is the nominal (recommended) resistor value that ensures a brake power on motor shaft of 137% / 145% / 160% for 1 minute.

**Ordering Numbers: Brake Resistors**

**Mains 380-500 V / 380-480 V**

		FC 301/302												
		Selected resistor												
		Standard IP 20						Aluminium Housed (Flatpack) IP65					Max. torque load <sup>b</sup>	
FC 301/ FC 302	P <sub>motor</sub> [kW]	R <sub>min</sub> [Ω]	Duty Cycle 10%			Duty Cycle 40%			R <sub>rec</sub> per item [Ω]	Duty cycle %	Order no. 175Uxxxx	FC 301	FC 302	
			R <sub>br,nom</sub> <sup>c</sup> [Ω]	R <sub>rec</sub> [Ω]	P <sub>br max</sub> [kW]	Order no. 175Uxxxx	R <sub>rec</sub> [Ω]	P <sub>br max</sub> [kW]						Order no. 175Uxxxx
PK37	0.37	620	1360.2	620	0.065	1840	830	0.450	1976	830Ω/100V	20	1000	137%	160%
PK55	0.55	620	915.0	620	0.065	1840	830	0.450	1976	830Ω/100V	20	1000	137%	160%
PK75	0.75	601	667.6	620	0.065	1840	620	0.260	1940	620Ω/100V	14	1001	137%	160%
PK75	0.75	601	667.6	-	-	-	-	-	-	620Ω/200V	40	0982	137%	160%
P1K1	1.1	408	452.8	425	0.095	1841	425	0.430	1941	430Ω/100V	8	1002	137%	160%
P1K1	1.1	408	452.8	-	-	-	-	-	-	430Ω/200V	20	0983	137%	160%
P1K5	1.5	297	330.4	310	0.250	1842	310	0.800	1942	310Ω/200V	16	0984	137%	160%
P2K2	2.2	200	222.6	210	0.285	1843	210	1.35	1943	210Ω/200V	9	0987	137%	160%
P3K0	3	145	161.4	150	0.430	1844	150	2.00	1944	150Ω/200V	5.5	0989	137%	160%
P3K0	3	145	161.4	-	-	-	-	-	-	300Ω/200V	12	2X0985 <sup>a</sup>	137%	160%
P4K0	4	108	119.6	110	0.600	1845	110	2.40	1945	240Ω/200V	11	2X0986 <sup>a</sup>	137%	160%
P5K5	5.5	77	86.0	80	0.850	1846	80	3.00	1946	160Ω/200V	6.5	2X0988 <sup>a</sup>	137%	160%
P7K5	7.5	56	62.4	65	1.0	1847	65	4.50	1947	130Ω/200V	4	2X0990 <sup>a</sup>	137%	160%
P11K	11	38	42.1	40	1.8	1848	40	5.00	1948	50Ω/200W	9	0993	137%	160%
P15K	15	27	30.5	30	2.8	1849	30	9.30	1949	35Ω/200W	5.5	0994	137%	160%
P15K	15	27	30.5	-	-	-	-	-	-	72Ω/200W	12	2X0992 <sup>a</sup>	137%	160%
P18K	18.5	22	24.5	25	3.5	1850	25	12.70	1950	50Ω/200W	11	2X0993 <sup>a</sup>	137%	160%
P22K	22	18	20.3	20	4.0	1851	20	13.00	1951	40Ω/200W	6.5	2X0996 <sup>a</sup>	137%	160%

<sup>a</sup> Order two pieces, resistors must be connected in parallel.

<sup>b</sup> Max. load with the resistor in Danfoss standard program.

<sup>c</sup> R<sub>br,nom</sub> is the nominal (recommended) resistor value that ensures a brake power on motor shaft of 137% / 145% / 160% for 1 minute.

— How to Order —

□ **Ordering Numbers: Harmonic Filters**

Harmonic filters are used to reduce mains harmonics.

- AHF 010: 10% current distortion
- AHF 005: 5% current distortion

380-415V, 50Hz				
I <sub>AHF,N</sub>	Typical Motor Used [kW]	Danfoss ordering number		FC 301/ FC 302
		AHF 005	AHF 010	
10 A	4, 5.5	175G6600	175G6622	P4K0, P5K5
19 A	7.5	175G6601	175G6623	P7K5
46 A	11	175G6602	175G6624	P11K
35 A	15, 18.5	175G6603	175G6625	P15K, P18K
43 A	22	175G6604	175G6626	P22K

440-480V, 60Hz				
I <sub>AHF,N</sub>	Typical Motor Used [HP]	Danfoss ordering number		FC 301/ FC 302
		AHF 005	AHF 010	
19 A	10, 15	175G6612	175G6634	P7K5
26 A	20	175G6613	175G6635	P15K
35 A	25, 30	175G6614	175G6636	P18K, P22K

500V, 50Hz				
I <sub>AHF,N</sub>	Typical Motor Used [kW]	Danfoss ordering number		FC 301/ FC 302
		AHF 005	AHF 010	
10 A	4, 5.5	175G6644	175G6656	P4K0, P5K5
19 A	7.5, 11	175G6645	175G6634	P7K5, P11K
26 A	15, 18.5	175G6646	175G6635	P15K, P18K
35 A	22	175G6647	175G6636	P22K

Matching the frequency converter and filter is pre-calculated based on 400V/480V and on a typical motor load (4 pole) and 160 % torque.

□ **Ordering Numbers: LC Filter Modules, 200-240 VAC**

Mains supply 3 x 200-240 V					
FC 301/ FC 302	LC filter enclosure	Rated current	Max. torque	Max. output	Ordering no.
		at 200 V	at CT/VT	frequency	
PK25 - P1K5	Bookstyle IP 20	7.8 A	160%	120 Hz	175Z0825
P2K2 - P3K7	Bookstyle IP 20	15.2 A	160%	120 Hz	175Z0826
PK25 - P3K7	Compact IP 20	15.2 A	160%	120 Hz	175Z0832



**NB!:**

When using LC filters, the switching frequency must be minimum 4.5 kHz (see par. 14-01).

## — How to Order —

□ **Ordering Numbers: LC Filter Modules,  
380-500 VAC**

Mains supply 3 x 380 - 500 V						
FC 301/ FC 302	LC filter enclosure	Rated current at 400/500 V	Max. torque at CT/VT	Max. output frequency	Power dissipation	Ordering no.
PK37-P3K0	Bookstyle IP20	7.2 A / 6.3 A	160%	120 Hz	-	175Z0825
P4K0-P7K5	Bookstyle IP20	16 A / 14.5 A	160%	120 Hz	-	175Z0826
PK37-P7K5	Compact IP20	16 A / 14.5 A	160%	120 Hz	-	175Z0832
<b>High overload torque</b>						
P11K	Compact IP20	24 A / 21.7 A	160%	60 Hz	125 W	175Z4606
P15K	Compact IP20	32 A / 27.9 A	160%	60 Hz	130 W	175Z4607
P18K	Compact IP20	37.5 A / 32 A	160%	60 Hz	140 W	175Z4608
P22K	Compact IP20	44 A / 41.4 A	160%	60 Hz	170 W	175Z4609
<b>Normal overload torque</b>						
P11K	Compact IP20	32 A / 27.9 A	110%	60 Hz	130 W	175Z4607
P15K	Compact IP20	37.5 A / 32 A	110%	60 Hz	140 W	175Z4608
P18K	Compact IP20	44 A / 41.4 A	110%	60 Hz	170 W	175Z4609
P22K	Compact IP20	61 A / 54 A	110%	60 Hz	250 W	175Z4610

LC filters for FC 300, 525 - 600 V, please contact Danfoss.

**NB!:**

When using LC filters, the switching frequency must be minimum 4.5 kHz (see par. 14-01).

— How to Order —



# How to Install

## □ Mechanical Installation

### □ Accessory Bag ≤ 7.5 kW

Find the following parts included in the FC 300 Accessory Bag.

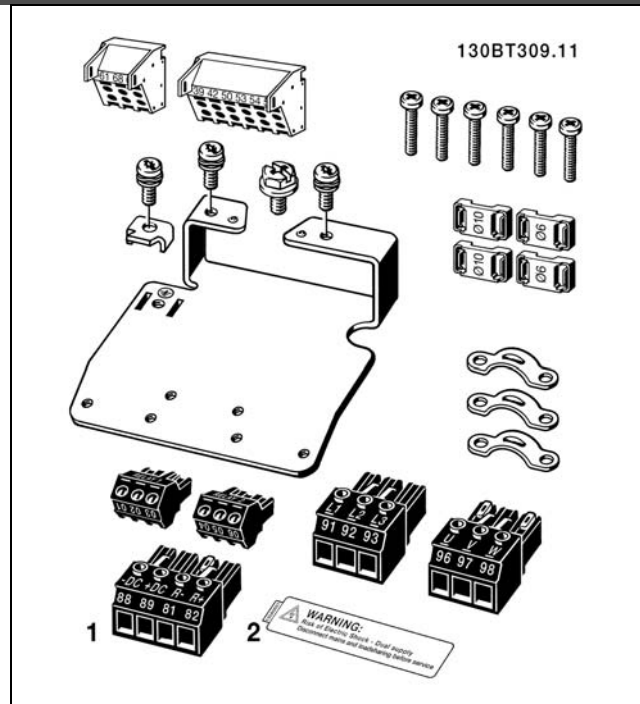

1 + 2 only available in units with brake chopper.  
There is only one relay connector for FC 301. (≤ 7.5 kW)  
For DC link connection (loadsharing) the connector 1 can be ordered separately (order number 130B1064).

— How to Install —

**Accessory Bag ≤ 7.5 kW, IP 55**

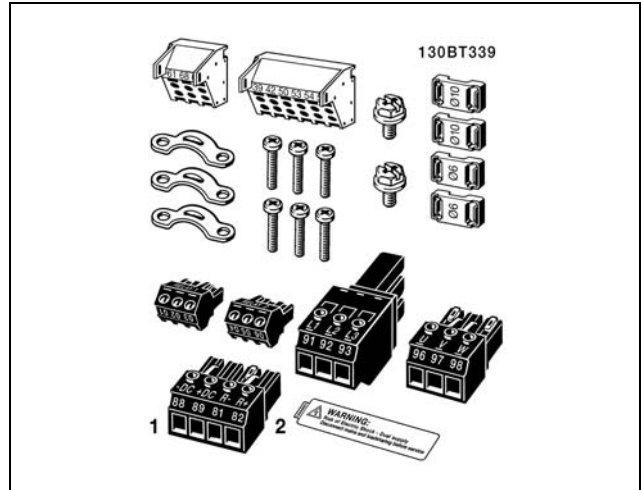

1 + 2 only available in units with brake chopper.  
 There is only one relay connector for FC 301.  
 (≤ 7.5 kW, IP55)

**Accessory Bag 11-22 kW**

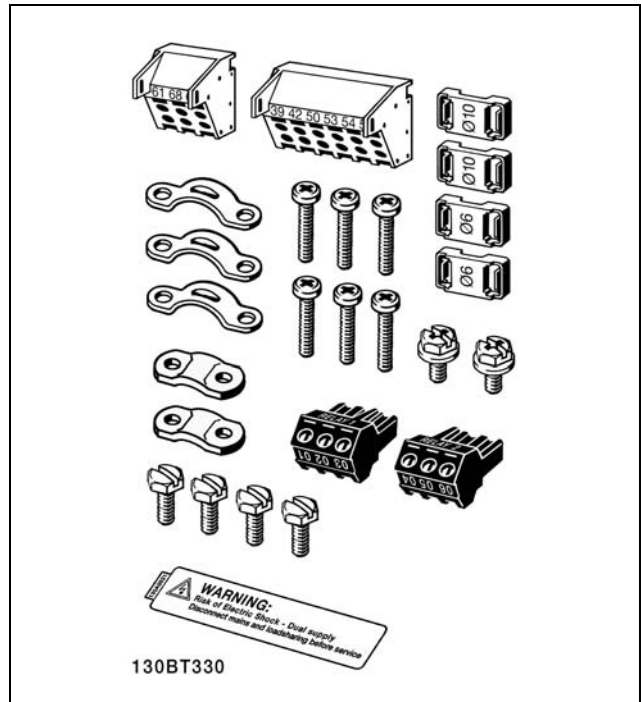

There is only one relay connector for FC 301. (11-22 kW)

## — How to Install —

### □ Mechanical mounting

1. Drill holes in accordance with the measurements given.
2. You must provide screws suitable for the surface on which you want to mount the FC 300. Retighten all four screws.

FC 300 IP20 allows side-by-side installation. Because of the need for cooling, there must be a minimum of 100 mm free air passage above and below the FC 300.

The back wall must always be solid.

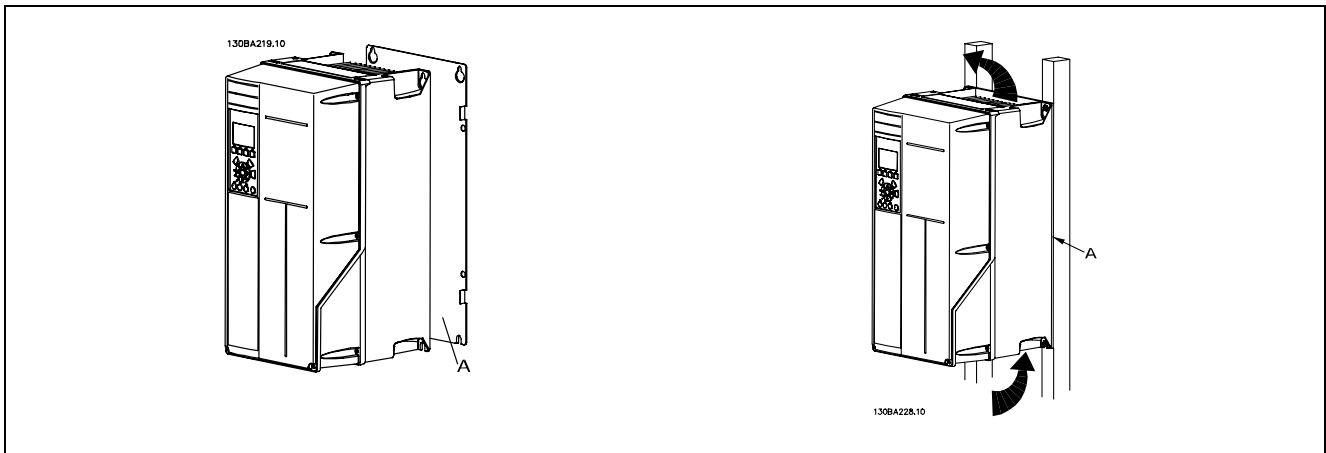

### □ Safety Requirements of Mechanical Installation



Pay attention to the requirements that apply to integration and field mounting kit. Observe the information in the list to avoid serious damage or injury, especially when installing large units.

The frequency converter is cooled by means of air circulation.

To protect the unit from overheating, it must be ensured that the ambient temperature *does not exceed the maximum temperature stated for the frequency converter* and that the 24-hour average temperature *is not exceeded*. Locate the maximum temperature and 24-hour average in the paragraph *Derating for Ambient Temperature*.

If the ambient temperature is in the range of 45 °C - 55 ° C, derating of the frequency converter will become relevant, see *Derating for Ambient Temperature*.

The service life of the frequency converter is reduced if derating for ambient temperature is not taken into account.

### □ Field Mounting

For field mounting the IP 21/IP 4X top/TYPE 1 kits or IP 54/55 units (planned) are recommended.

## □ Electrical Installation



**NB!:**  
**Cables General**

Always comply with national and local regulations on cable cross-sections.

Tightening-up Torque		
FC size	Cable for:	Tightening up torque
0.25-7.5 kW	Line, Brake resistor, load sharing Motor cable	0.5-0.6 Nm 1.8 Nm
11-15 kW	Line, Brake resistor, load sharing Motor cable	1.8 Nm
11-15 kW	Motor cable	1.8 Nm
	Relay	0.5-0.6 Nm
	Earth	2-3 Nm

### □ Removal of Knockouts for Extra Cables

1. Remove cable entry from the frequency converter (Avoiding foreign parts in the frequency converter when removing knockouts)
2. Cable entry has to be supported around the knockout you intend to remove.
3. The knockout can now be removed with a strong mandrel and a hammer.
4. Remove burrs from the hole.
5. Mount Cable entry on frequency converter.

### □ Connection to Mains and Earthing



**NB!:**  
The plug connector for power can be removed.

1. Make sure the FC 300 is properly earthed. Connect to earth connection (terminal 95). Use screw from the accessory bag.
2. Place plug connector 91, 92, 93 from the accessory bag onto the terminals labelled MAINS at the bottom of FC 300.
3. Connect mains wires to the mains plug connector.



The earth connection cable cross section must be at least 10 mm<sup>2</sup> or 2 rated mains wires terminated separately according to EN 50178.

The mains connection is fitted to the main switch if this is included.

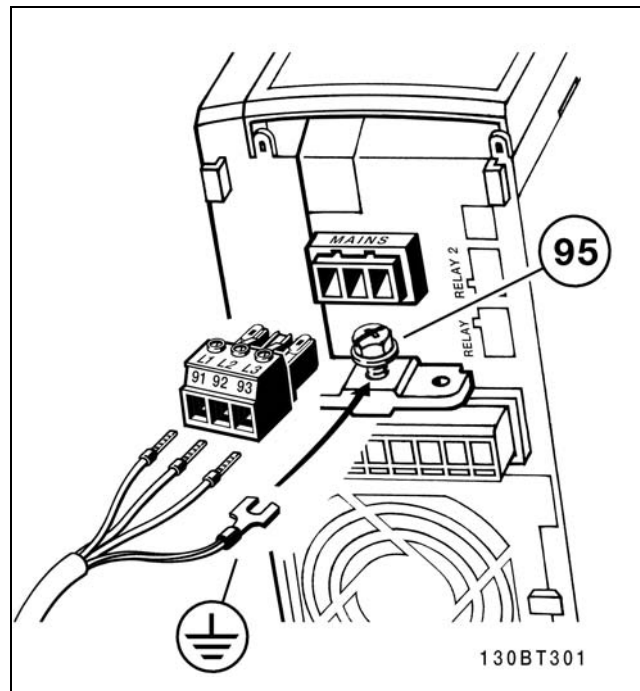

How to connect to mains and earthing (A2 and A3 enclosure).

— How to Install —

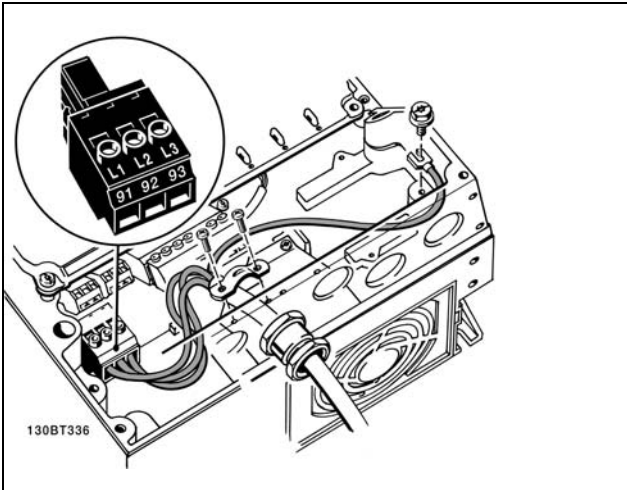

How to connect to mains and earthing (A5 enclosure).

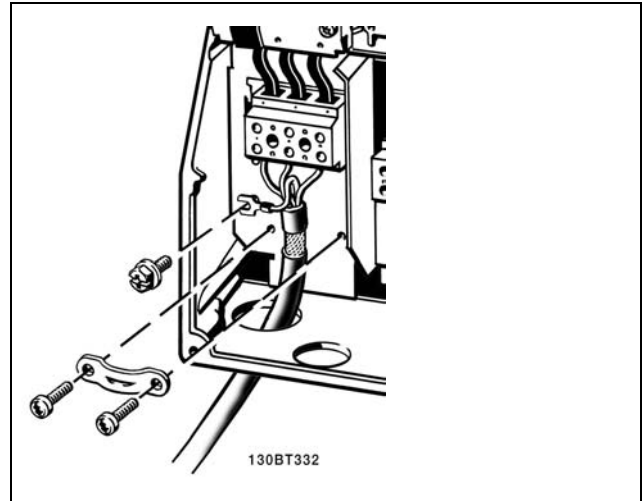

How to connect to mains and earthing (B1 and B2 enclosure).



**NB!:**

Check that mains voltage corresponds to the mains voltage of the FC 300 name plate.



**IT Mains**

Do not connect 400 V frequency converters with RFI-filters to mains supplies with a voltage between phase and earth of more than 440 V.

For IT mains and delta earth (grounded leg), mains voltage may exceed 440 V between phase and earth.

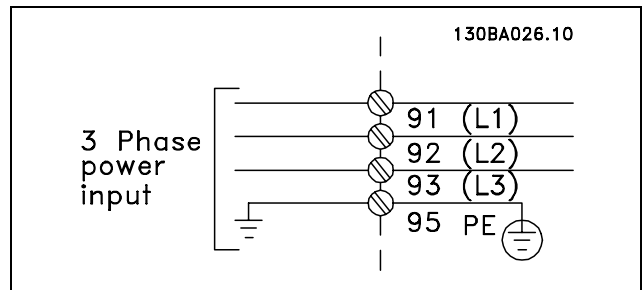

Terminals for mains and earthing.

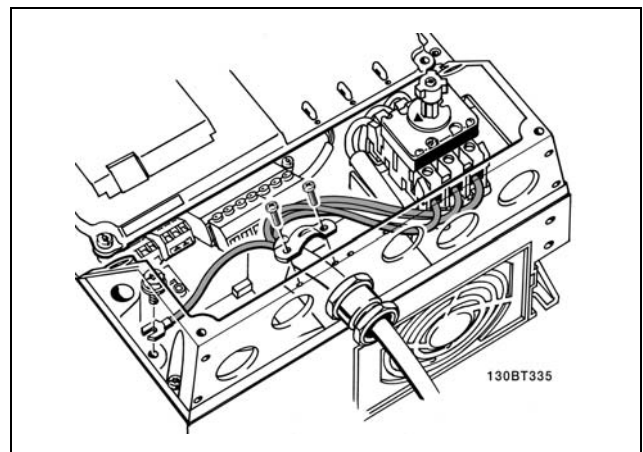

How to connect to mains and earthing with disconnector (A5 enclosure).

— How to Install —

□ **Motor Connection**



**NB!:**

Motor cable must be screened/armoured. If an unscreened/unarmoured cable is used, some EMC requirements are not complied with. For more information, see *EMC specifications*.

1. Fasten decoupling plate to the bottom of FC 300 with screws and washers from the accessory bag.
2. Attach motor cable to terminals 96 (U), 97 (V), 98 (W).
3. Connect to earth connection (terminal 99) on decoupling plate with screws from the accessory bag.
4. Insert terminals 96 (U), 97 (V), 98 (W) and motor cable to terminals labelled MOTOR.
5. Fasten screened cable to decoupling plate with screws and washers from the accessory bag.

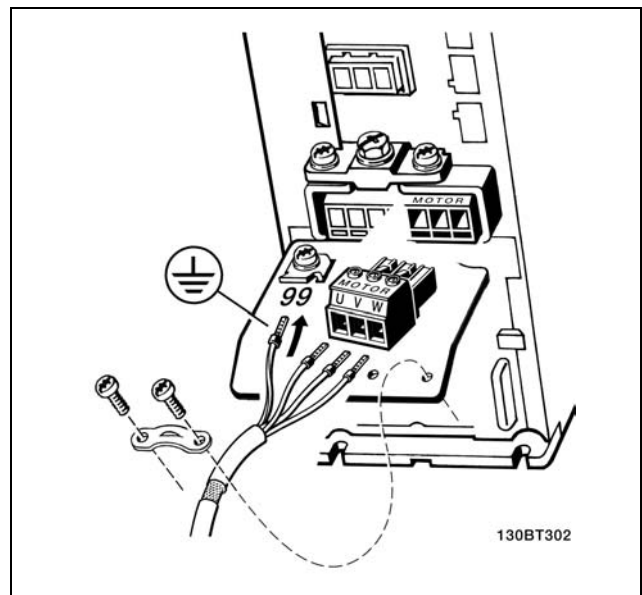
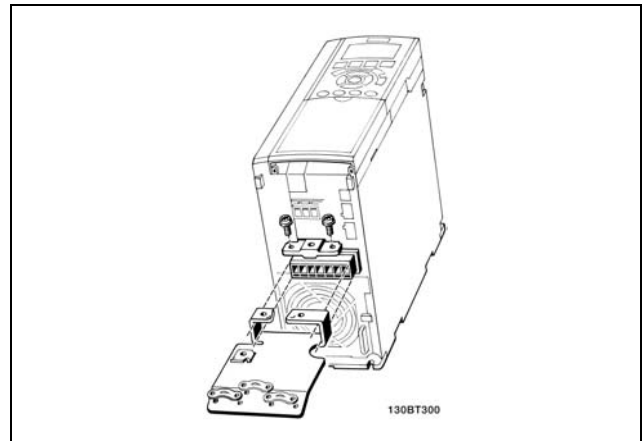

≤ 7.5 kW IP20

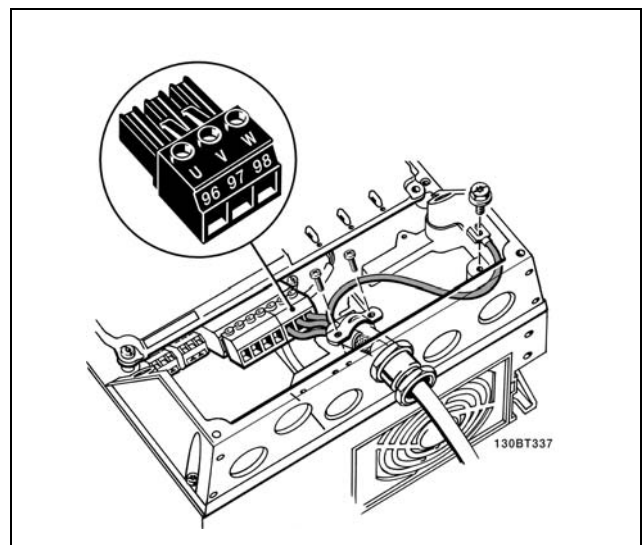

Motor connection ≤ 7.5 kW IP55

— How to Install —

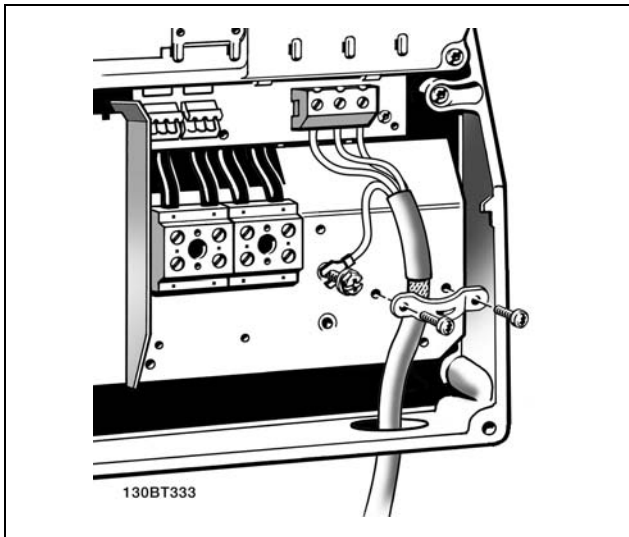

11-22 kW IP21

All types of three-phase asynchronous standard motors can be connected to the FC 300. Normally, small motors are star-connected (230/400 V, D/Y). Large motors are delta-connected (400/690 V, D/Y). Refer to the motor name plate for correct connection mode and voltage.

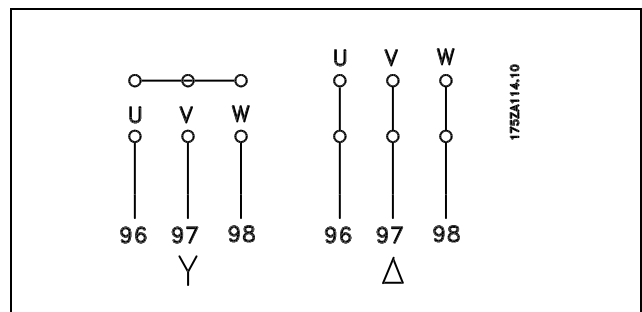

**NB!:**

In motors without phase insulation paper or other insulation reinforcement suitable for operation with voltage supply (such as a frequency converter), fit an LC filter on the output of the FC 300.

No.	96	97	98	Motor voltage 0-100% of mains voltage. 3 wires out of motor
	U	V	W	
	U1	V1	W1	6 wires out of motor, Delta-connected
	W2	U2	V2	
	U1	V1	W1	6 wires out of motor, Star-connected U2, V2, W2 to be interconnected separately (optional terminal block)
No.	99			Earth connection
	PE			

## — How to Install —

□ **Motor Cables**

See section *General Specifications* for correct dimensioning of motor cable cross-section and length.

- Use a screened/armoured motor cable to comply with EMC emission specifications.
- Keep the motor cable as short as possible to reduce the noise level and leakage currents.
- Connect the motor cable screen to both the decoupling plate of the FC 300 and to the metal cabinet of the motor.
- Make the screen connections with the largest possible surface area (cable clamp). This is done by using the supplied installation devices in the FC 300.
- Avoid mounting with twisted screen ends (pigtailed), which will spoil high frequency screening effects.
- If it is necessary to split the screen to install a motor isolator or motor relay, the screen must be continued with the lowest possible HF impedance.

□ **Electrical Installation of Motor Cables****Screening of cables**

Avoid installation with twisted screen ends (pigtailed). They spoil the screening effect at higher frequencies. If it is necessary to break the screen to install a motor isolator or motor contactor, the screen must be continued at the lowest possible HF impedance.

**Cable length and cross-section**

The frequency converter has been tested with a given length of cable and a given cross-section of that cable. If the cross-section is increased, the cable capacitance - and thus the leakage current - may increase, and the cable length must be reduced correspondingly.

**Switching frequency**

When frequency converters are used together with LC filters to reduce the acoustic noise from a motor, the switching frequency must be set according to the LC filter instruction in *Par. 14-01*.

**Aluminium conductors**

Aluminium conductors are not recommended. Terminals can accept aluminium conductors but the conductor surface has to be clean and the oxidation must be removed and sealed by neutral acid free Vaseline grease before the conductor is connected.

Furthermore, the terminal screw must be retightened after two days due to the softness of the aluminium. It is crucial to keep the connection a gas tight joint, otherwise the aluminium surface will oxidize again.



— How to Install —

□ **Fuses**

**Branch circuit protection:**

In order to protect the installation against electrical and fire hazard, all branch circuits in an installation, switch gear, machines etc., must be shortcircuit and overcurrent protected according to the national/international regulations.

**Short circuit protection:**

The frequency converter must be protected against short-circuit to avoid electrical or fire hazard. Danfoss recommends using the fuses mentioned below to protect service personnel or other equipment in case of an internal failure in the drive. The frequency converter provides full short circuit protection in case of a short-circuit on the motor output.

**Over current protection:**

Provide overload protection to avoid fire hazard due to overheating of the cables in the installation. The frequency converter is equipped with an internal over current protection that can be used for upstream overload protection (UL-applications excluded). See par. 4-18. Moreover, fuses or circuit breakers can be used to provide the over current protection in the installation. Over current protection must always be carried out according to national regulations.

Fuses must be designed for protection in a circuit capable of supplying a maximum of 100,000 A<sub>rms</sub> (symmetrical), 500 V maximum.

**Non UL compliance**

If UL/cUL is not to be complied with, we recommend using the following fuses, which will ensure compliance with EN50178:

In case of malfunction, not following the recommendation may result in unnecessary damage of the frequency converter.

FC 30X	Max. fuse size	Voltage	Type
K25-K75	10A <sup>1)</sup>	200-240 V	type gG
1K1-2K2	20A <sup>1)</sup>	200-240 V	type gG
3K0-3K7	32A <sup>1)</sup>	200-240 V	type gG
K37-1K5	10A <sup>1)</sup>	380-500 V	type gG
2K2-4K0	20A <sup>1)</sup>	380-500 V	type gG
5K5-7K5	32A <sup>1)</sup>	380-500 V	type gG
11K	63A <sup>1)</sup>	380-500 V	type gG
15K	63A <sup>1)</sup>	380-500 V	type gG
18K	63A <sup>1)</sup>	380-500 V	type gG
22K	80A <sup>1)</sup>	380-500 V	type gG

1) Max. fuses - see national/international regulations for selecting an applicable fuse size.

**UL Compliance**

**200-240 V**

FC 30X	Bussmann	Bussmann	Bussmann	SIBA	Littel fuse	Ferraz-Shawmut	Ferraz-Shawmut
kW	Type RK1	Type J	Type T	Type RK1	Type RK1	Type CC	Type RK1
2-7.5	KTN-R10	JKS-10	JJN-10	5017906-010	KLN-R10	ATM-R10	A2K-10R
1.1-2.2	KTN-R20	JKS-20	JJN-20	5017906-020	KLN-R20	ATM-R20	A2K-20R
3.0-3.7	KTN-R30	JKS-30	JJN-30	5012406-032	KLN-R30	ATM-R30	A2K-30R

— How to Install —

**380-500 V, 525-600 V**

FC 30X	Bussmann	Bussmann	Bussmann	SIBA	Littel fuse	Ferraz-Shawmut	Ferraz-Shawmut
kW	Type RK1	Type J	Type T	Type RK1	Type RK1	Type CC	Type RK1
0.37-1.5	KTS-R10	JKS-10	JJS-10	5017906-010	KLS-R10	ATM-R10	A6K-10R
2.2-4.0	KTS-R20	JKS-20	JJS-20	5017906-020	KLS-R20	ATM-R20	A6K-20R
5.5-7.5	KTS-R30	JKS-30	JJS-30	5012406-032	KLS-R30	ATM-R30	A6K-30R
11.0	KTS-R40	JKS-40	JJS-40	5014006-040	KLS-R40		A6K-40R
15.0	KTS-R50	JKS-50	JJS-50	5014006-050	KLS-R50		A6K-50R
18.0	KTS-R60	JKS-60	JJS-60	5014006-063	KLS-R60		A6K-60R
22.0	KTS-R80	JKS-80	JJS-80	5014006-100	KLS-R80		A6K-80R

KTS-fuses from Bussmann may substitute KTN for 240 V frequency converters.  
 FWH-fuses from Bussmann may substitute FWX for 240 V frequency converters.  
 KLSR fuses from LITTEL FUSE may substitute KLNR fuses for 240 V frequency converters.  
 L50S fuses from LITTEL FUSE may substitute L50S fuses for 240 V frequency converters.  
 A6KR fuses from FERRAZ SHAWMUT may substitute A2KR for 240 V frequency converters.  
 A50X fuses from FERRAZ SHAWMUT may substitute A25X for 240 V frequency converters.

— How to Install —

□ **Access to Control Terminals**

All terminals to the control cables are located underneath the terminal cover on the front of the frequency converter. Remove the terminal cover by means of a screwdriver (see illustration).

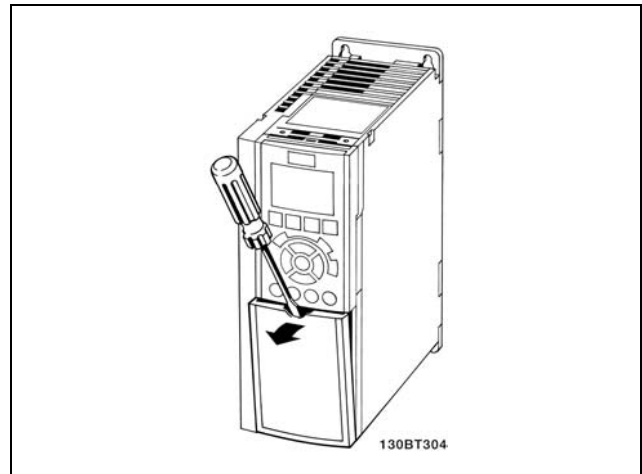

A1, A2 and A3 enclosures

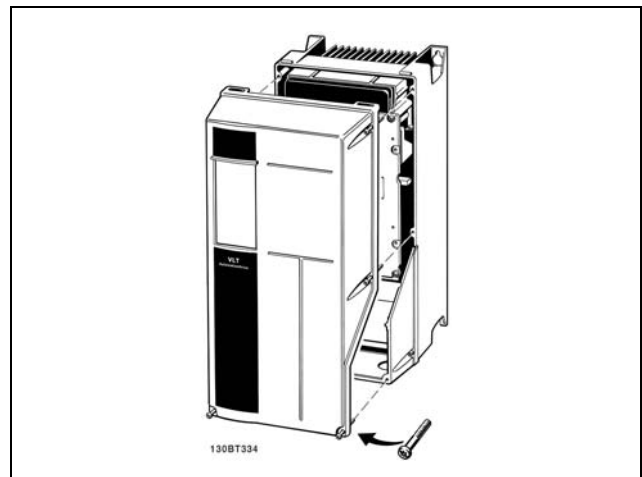

A5, B1 and B2 enclosures

□ **Control Terminals (FC 301)**

Drawing reference numbers:

1. 8 pole plug digital I/O.
2. 3 pole plug RS485 Bus.
3. 6 pole analog I/O.
4. USB Connection.

**Control Terminals (FC 302)**

Drawing reference numbers:

1. 10 pole plug digital I/O.
2. 3 pole plug RS485 Bus.
3. 6 pole analog I/O.
4. USB Connection.

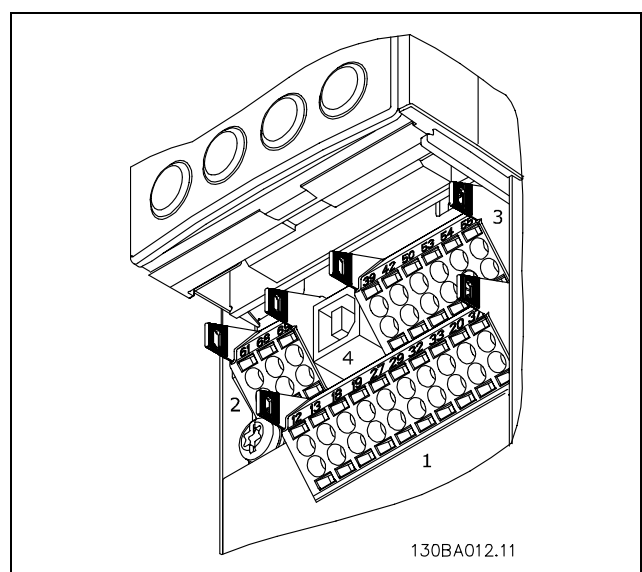

Control terminals (all enclosures)

— How to Install —

□ **Electrical Installation, Control Terminals**

To mount the cable to the terminal:

1. Strip isolation of 9-10 mm
2. Insert a screw driver in the square hole.
3. Insert the cable in the adjacent circular hole.
4. Remove the screw driver. The cable is now mounted to the terminal.

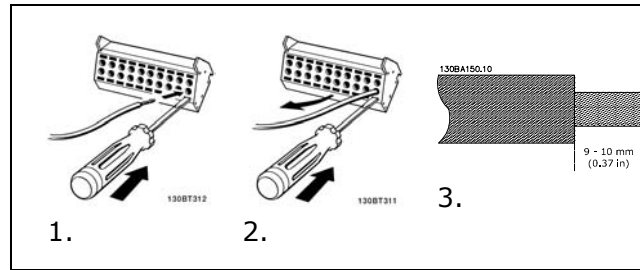

To remove the cable from the terminal:

1. Insert a screw driver in the square hole.
2. Pull out the cable.

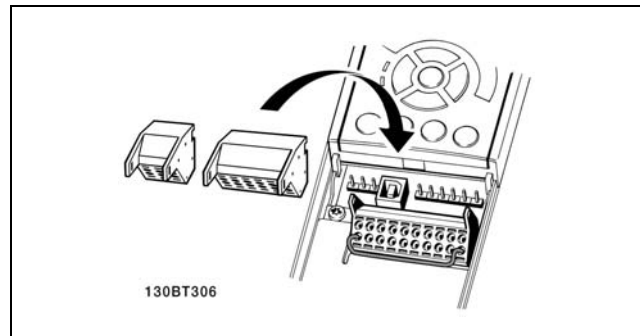

Assembling of IP55 / NEMA TYPE 12 (A5 housing) with mains disconnector

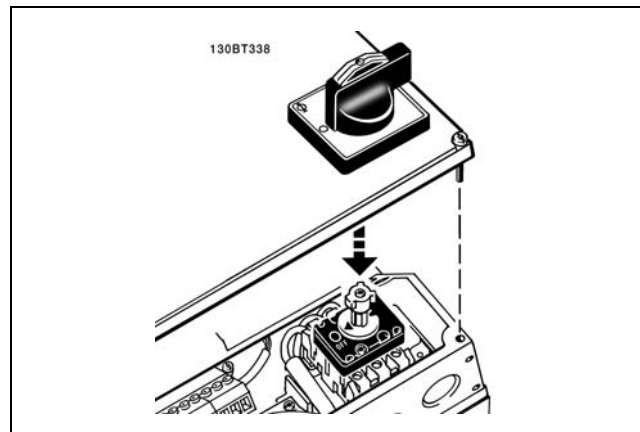

□ **Basic Wiring Example**

1. Mount terminals from the accessory bag to the front of the FC 300.
2. Connect terminals 18, 27 and 37 (FC 302 only) to +24 V (terminal 12/13)

Default settings:

- 18 = start
- 27 = coast inverse
- 37 = safe stop inverse

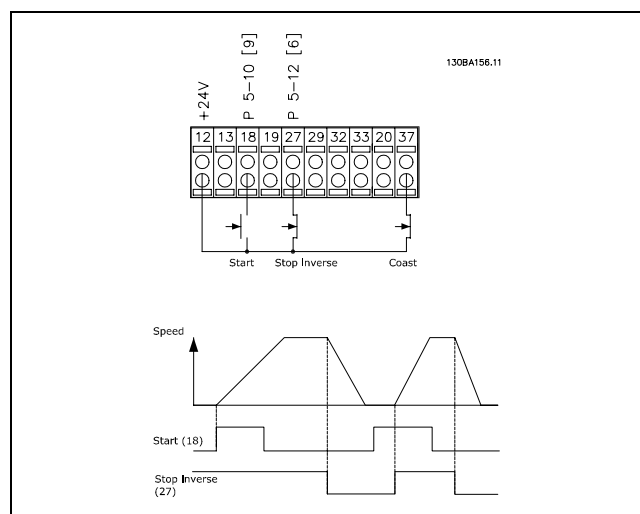

— How to Install —

□ Electrical Installation, Control Cables

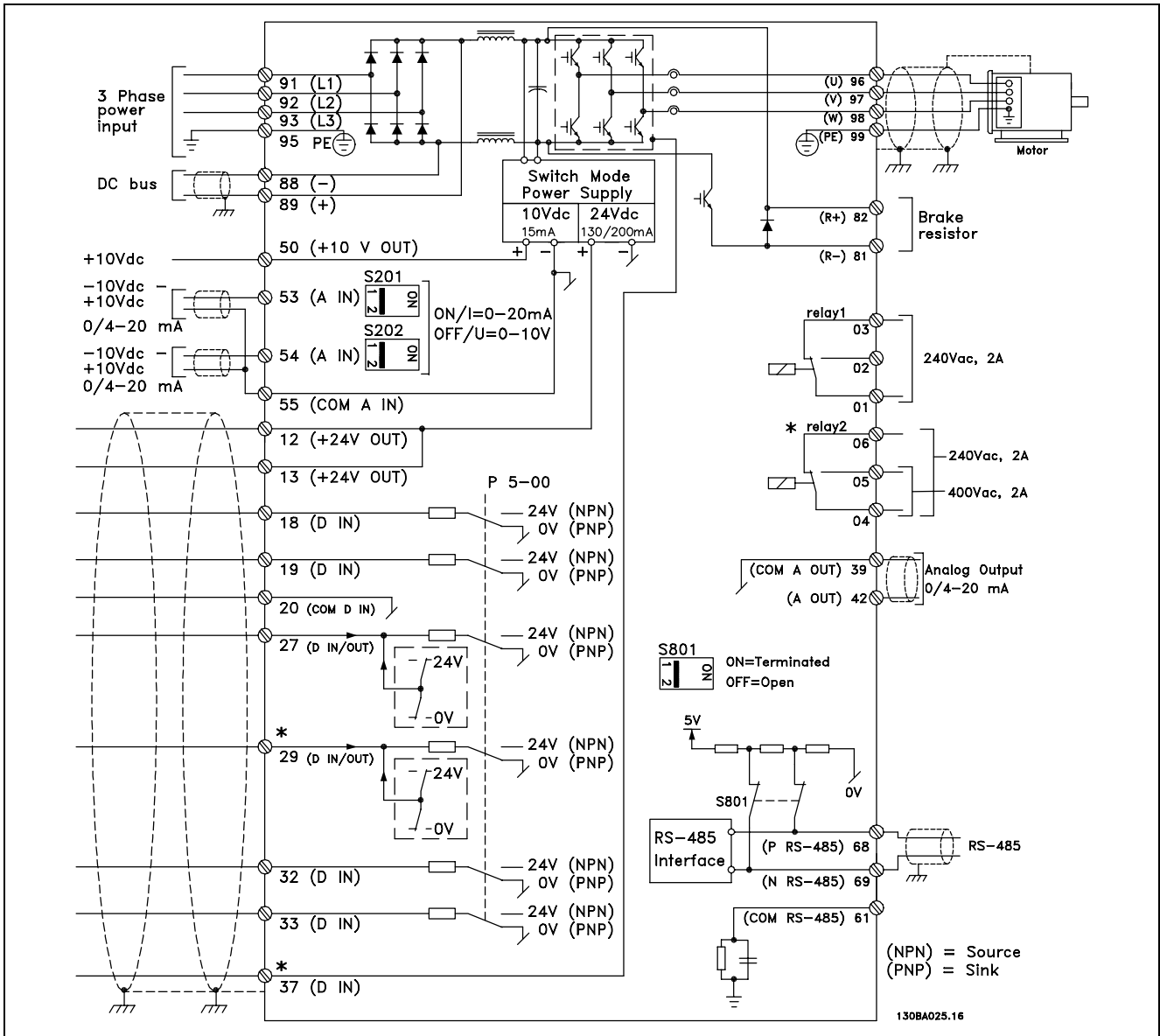

Diagram showing all electrical terminals.  
 Terminal 37 is the input to be used for Safe Stop. For instructions on Safe Stop installation please refer to the section *Safe Stop Installation*.  
 \* Terminal 29 and 37, relay 2 are not included in FC 301.

Very long control cables and analog signals may in rare cases and depending on installation result in 50/60 Hz earth loops due to noise from mains supply cables.

If this occurs, you may have to break the screen or insert a 100 nF capacitor between screen and chassis.

The digital and analog in- and outputs must be connected separately to the FC 300 common inputs (terminal 20, 55, 39) to avoid ground currents from both groups to affect other groups. For example, switching on the digital input may disturb the analog input signal.

— How to Install —



**NB!:**  
Control cables must be screened/armoured.

1. Use a clamp from the accessory bag to connect the screen to the FC 300 decoupling plate for control cables.

See section entitled *Earthing of Screened/Armoured Control Cables* for the correct termination of control cables.

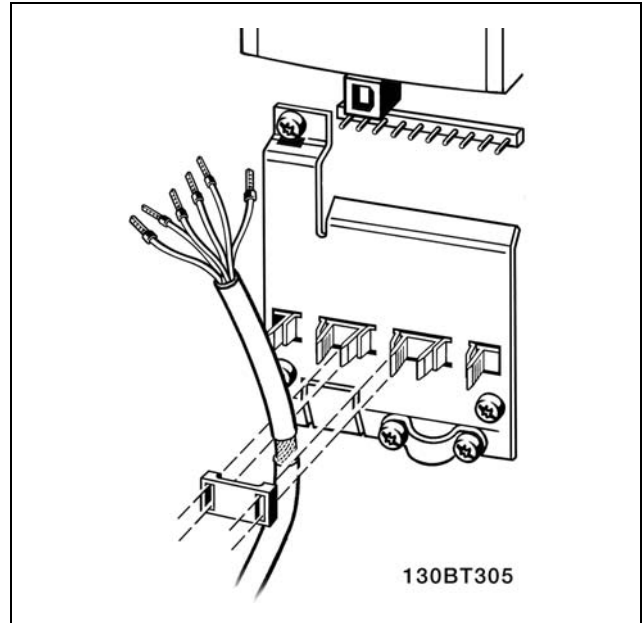

□ **Switches S201, S202, and S801**

Switches S201 (A53) and S202 (A54) are used to select a current (0-20 mA) or a voltage (-10 to 10 V) configuration of the analog input terminals 53 and 54 respectively.

Switch S801 (BUS TER.) can be used to enable termination on the RS-485 port (terminals 68 and 69).

See drawing *Diagram showing all electrical terminals* in section *Electrical Installation*.

Default setting:

- S201 (A53) = OFF (voltage input)
- S202 (A54) = OFF (voltage input)
- S801 (Bus termination) = OFF

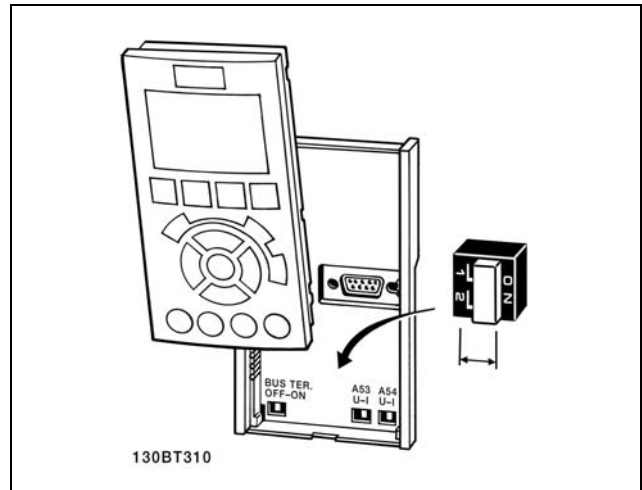

— How to Install —

□ **Final Set-Up and Test**

To test the set-up and ensure that the frequency converter is running, follow these steps.

**Step 1. Locate the motor name plate.**



**NB!:**

The motor is either star- (Y) or delta-connected ( $\Delta$ ). This information is located on the motor name plate data.

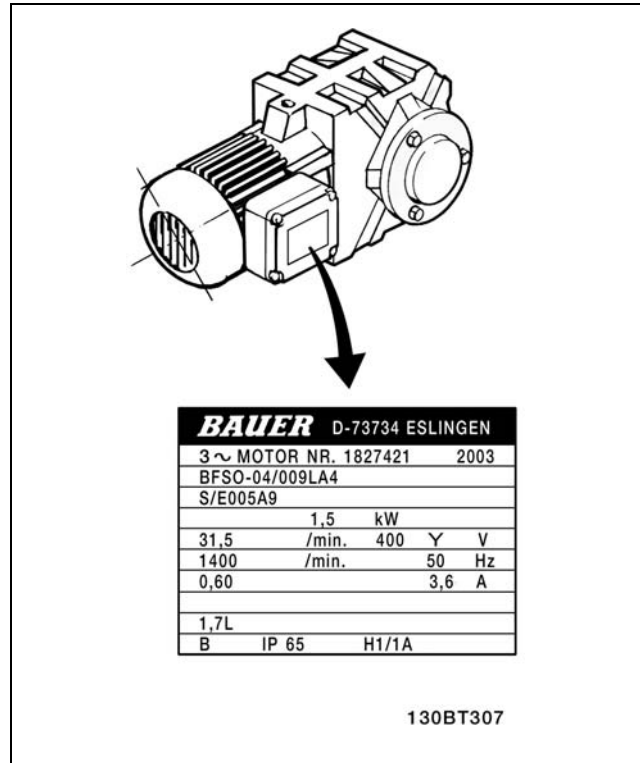

**Step 2. Enter the motor name plate data in this parameter list.**

To access this list first press the [QUICK MENU] key then select "Q2 Quick Setup".

1.	Motor Power [kW] or Motor Power [HP]	par. 1-20 par. 1-21
2.	Motor Voltage	par. 1-22
3.	Motor Frequency	par. 1-23
4.	Motor Current	par. 1-24
5.	Motor Nominal Speed	par. 1-25

**Step 3. Activate the Automatic Motor Adaptation (AMA)**

Performing an AMA will ensure optimum performance. The AMA measures the values from the motor model equivalent diagram.

1. Connect terminal 37 to terminal 12 (FC 302).
2. Connect terminal 27 to terminal 12 or set par. 5-12 to 'No function' (par. 5-12 [0]).
3. Activate the AMA par. 1-29.
4. Choose between complete or reduced AMA. If an LC filter is mounted, run only the reduced AMA, or remove the LC filter during the AMA procedure.
5. Press the [OK] key. The display shows "Press [Hand on] to start".
6. Press the [Hand on] key. A progress bar indicates if the AMA is in progress.

— How to Install —

**Stop the AMA during operation**

1. Press the [OFF] key - the frequency converter enters into alarm mode and the display shows that the AMA was terminated by the user.

**Successful AMA**

1. The display shows "Press [OK] to finish AMA".
2. Press the [OK] key to exit the AMA state.

**Unsuccessful AMA**

1. The frequency converter enters into alarm mode. A description of the alarm can be found in the *Troubleshooting* section.
2. "Report Value" in the [Alarm Log] shows the last measuring sequence carried out by the AMA, before the frequency converter entered alarm mode. This number along with the description of the alarm will assist you in troubleshooting. If you contact Danfoss Service, make sure to mention number and alarm description.



**NB!:**

Unsuccessful AMA is often caused by incorrectly registered motor name plate data or too big difference between the motor power size and the FC 300 power size.

**Step 4. Set speed limit and ramp time**

Set up the desired limits for speed and ramp time.

Minimum Reference	par. 3-02
Maximum Reference	par. 3-03

Motor Speed Low Limit	par. 4-11 or 4-12
Motor Speed High Limit	par. 4-13 or 4-14

Ramp-up Time 1 [s]	par. 3-41
Ramp-down Time 1 [s]	par. 3-42



— How to Install —

□ **Safe Stop Installation (FC 302 only)**

To carry out an installation of a Category 0 Stop (EN60204) in conformance with Safety Category 3 (EN954-1), follow these instructions:

1. The bridge (jumper) between Terminal 37 and 24 V DC of FC 302 must be removed. Cutting or breaking the jumper is not sufficient. Remove it entirely to avoid short-circuiting. See jumper on illustration.
2. Connect terminal 37 to 24 V DC by a short-circuit protected cable. The 24 V DC voltage supply must be interruptible by an EN954-1 Category 3 circuit interrupt device. If the interrupt device and the frequency converter are placed in the same installation panel, you can use a regular cable instead of a protected one.

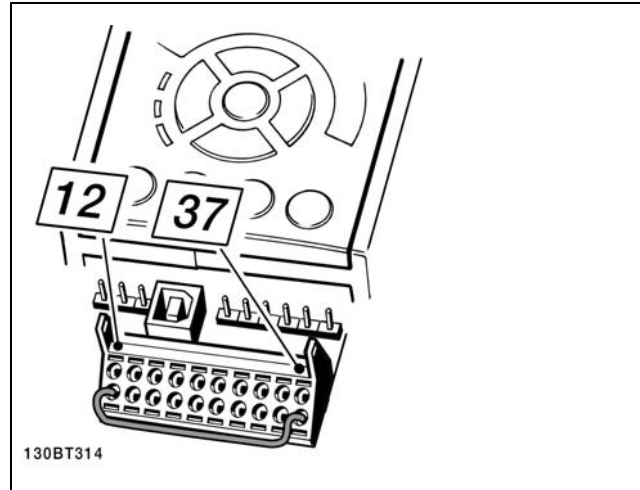

Bridge jumper between terminal 37 and 24 VDC.

The illustration below shows a Stopping Category 0 (EN 60204-1) with safety Cat. 3 (EN 954-1). The circuit interrupt is caused by an opening door contact. The illustration also shows how to connect a non-safety related hardware coast.

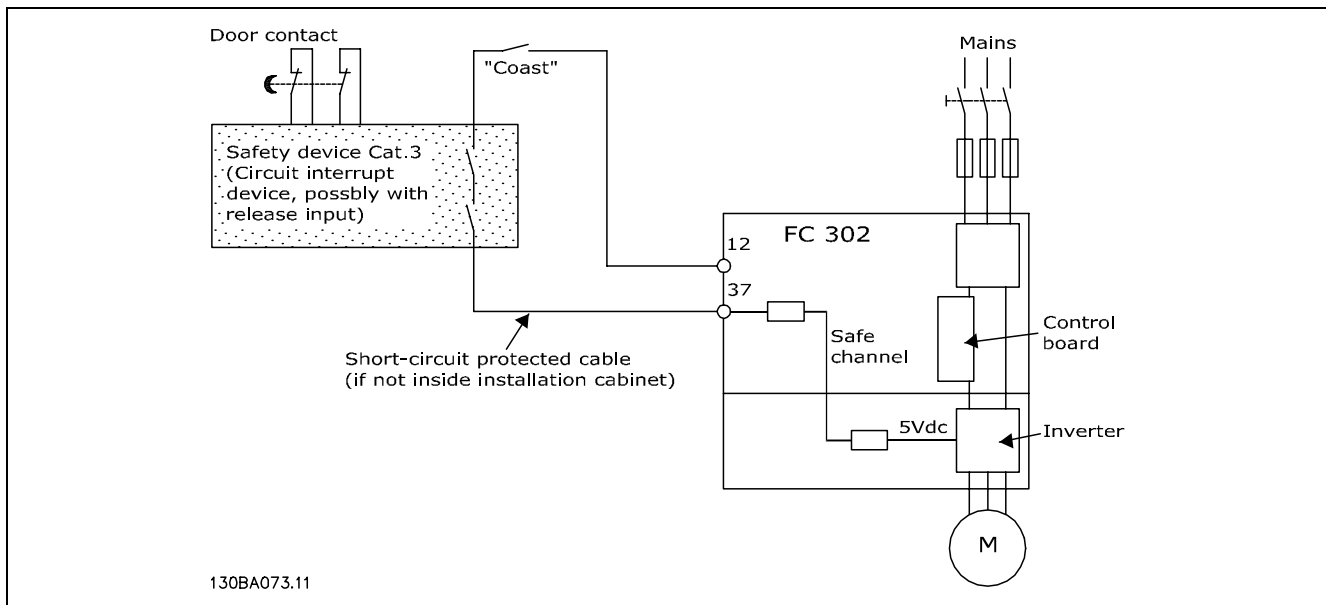

Illustration of the essential aspects of an installation to achieve a Stopping Category 0 (EN 60204-1) with safety Cat. 3 (EN 954-1).

## — How to Install —

**□ Safe Stop Commissioning Test**

After installation and before first operation, perform a commissioning test of an installation or application making use of FC 300 Safe Stop.

Moreover, perform the test after each modification of the installation or application, which the FC 300 Safe Stop is part of.

The commissioning test:

1. Remove the 24 V DC voltage supply to terminal 37 by the interrupt device while the motor is driven by the FC 302 (i.e. mains supply is not interrupted). The test step is passed if the motor reacts with a coast and the mechanical brake (if connected) is activated.
2. Then send Reset signal (via Bus, Digital I/O, or [Reset] key). The test step is passed if the motor remains in the Safe Stop state, and the mechanical brake (if connected) remains activated.
3. Then reapply 24 V DC to terminal 37. The test step is passed if the motor remains in the coasted state, and the mechanical brake (if connected) remains activated.
4. Then send Reset signal (via Bus, Digital I/O, or [Reset] key). The test step is passed if the motor gets operational again.
5. The commissioning test is passed if all four test steps are passed.

— How to Install —

□ **Additional Connections**

□ **Load Sharing**

With load sharing you can connect several frequency converter's DC intermediate circuits if you extend the installation using extra fuses and AC coils (see illustration).

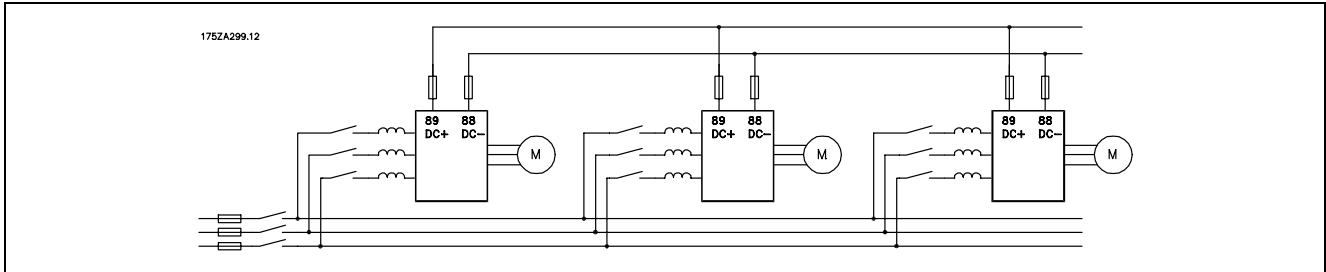

**NB!:**

Load sharing cables must be screened/armoured. If an unscreened/unarmoured cable is used, some EMC requirements are not complied with.



Voltage levels of up to 975 V DC may occur between terminals 88 and 89.

No.	88	89	Loadsharing
	DC -	DC +	

□ **Installation of Loadsharing**

The connection cable must be screened and the max. length from the frequency converter to the DC bar is 25 metres.



**NB!:**

Load sharing calls for extra equipment and safety considerations. For further information, see Loadsharing Instructions MI.50.NX.YY.

□ **Brake Connection Option**

The connection cable to the brake resistor must be screened/armoured.

No.	81	82	Brake resistor
	R-	R+	terminals



**NB!:**

Dynamic brake calls for extra equipment and safety considerations. For further information, see the Instruction *Brake Resistors for Horizontal Applications*, MI50SXYY.

1. Use cable clamps to connect the screen to the metal cabinet of the frequency converter and to the decoupling plate of the brake resistor.
2. Dimension the cross-section of the brake cable to match the brake current.

— How to Install —



**NB!:**

Voltages up to 975 V DC (@ 600 V AC) may occur between the terminals.



**NB!:**

If a short circuit in the brake IGBT occurs, prevent power dissipation in the brake resistor by using a mains switch or contactor to disconnect the mains for the frequency converter. Only the frequency converter shall control the contactor.

□ **Relay Connection**

To set relay output, see par. group 5-4\* Relays.

No.	01 - 02	make (normally open)
	01 - 03	break (normally closed)
	04 - 05	make (normally open)
	04 - 06	break (normally closed)

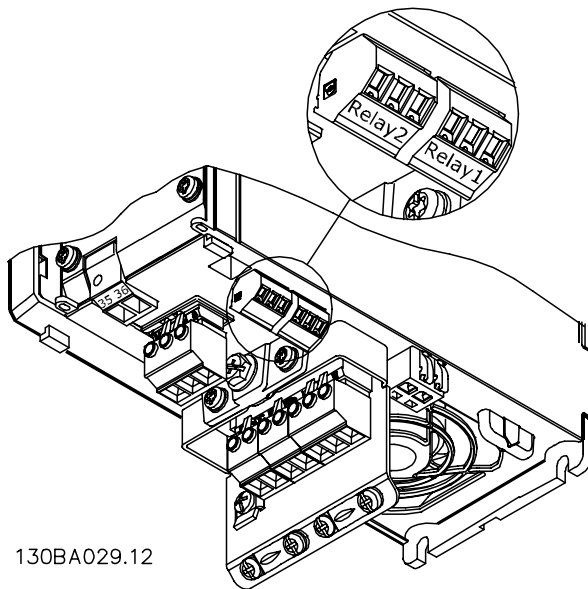

130BA029.12

Terminals for relay connection ( $\leq 7.5$  kW)  
(A1, A2 and A3 enclosures).

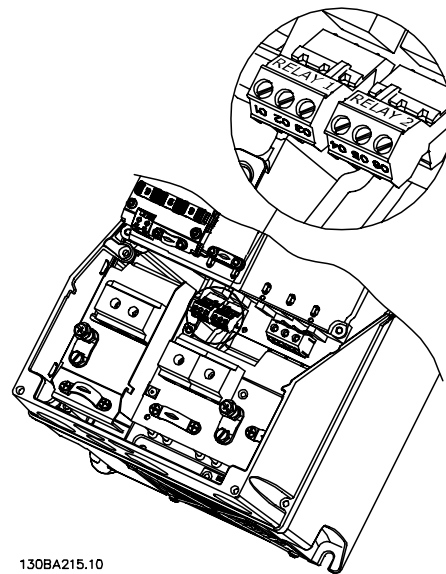

130BA215.10

Terminals for relay connection (11-22 kW)  
(A5, B1 and B2 enclosures).

— How to Install —

□ **Relay Output**

**Relay 1**

- Terminal 01: common
- Terminal 02: normal open 240 V AC
- Terminal 03: normal closed 240 V AC

**Relay 2 (FC 302 only)**

- Terminal 04: common
- Terminal 05: normal open 400 V AC
- Terminal 06: normal closed 240 V AC

Relay 1 and relay 2 are programmed in par. 5-40, 5-41, and 5-42.

Additional relay outputs by using option module MCB 105.

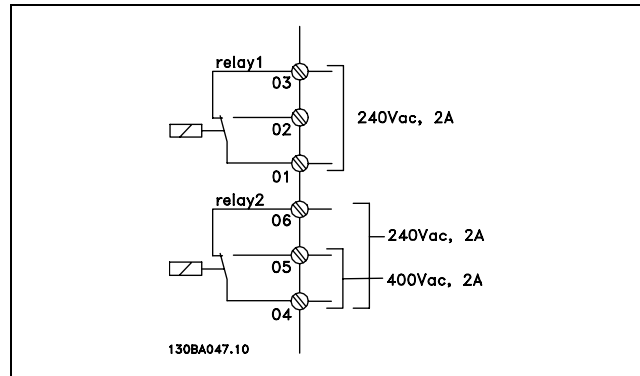

□ **Parallel Connection of Motors**

The frequency converter can control several parallel-connected motors. The total current consumption of the motors must not exceed the rated output current  $I_{INV}$  for the frequency converter. This is only recommended when U/f is selected in par. 1-01.



**NB!:**

When motors are connected in parallel, par. 1-02 *Automatic Motor Adaptation (AMA)* cannot be used, and par. 1-01 *Motor Control Principle* must be set to *Special motor characteristics (U/f)*.

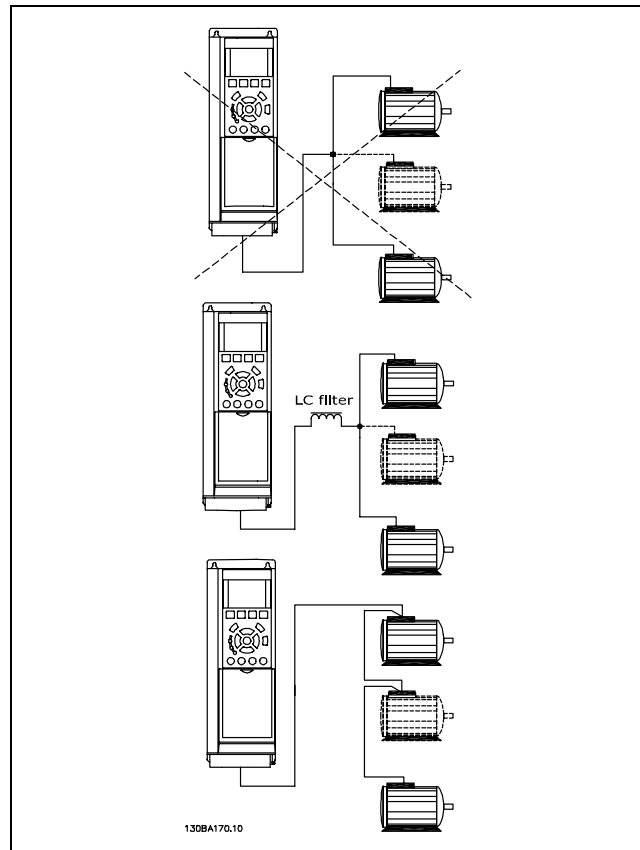

Problems may arise at start and at low RPM values if motor sizes are widely different because small motors' relatively high ohmic resistance in the stator calls for a higher voltage at start and at low RPM values.

The electronic thermal relay (ETR) of the frequency converter cannot be used as motor protection for the individual motor of systems with parallel-connected motors. Provide further motor protection by e.g. thermistors in each motor or individual thermal relays. (Circuit breakers are not suitable as protection).

— How to Install —

□ **Direction of Motor Rotation**

The default setting is clockwise rotation with the frequency converter output connected as follows.

- Terminal 96 connected to U-phase
- Terminal 97 connected to V-phase
- Terminal 98 connected to W-phase

The direction of motor rotation is changed by switching two motor phases.

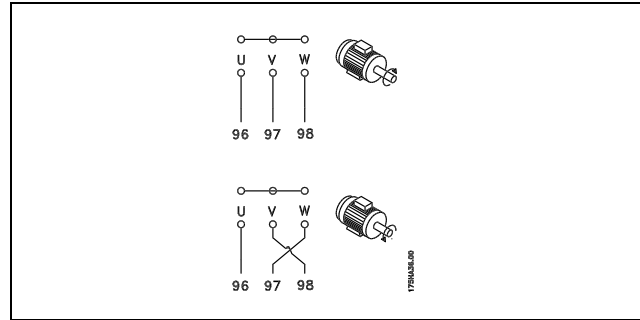

□ **Motor Thermal Protection**

The electronic thermal relay in FC 300 has received the UL-approval for single motor protection, when par. 1-90 *Motor Thermal Protection* is set for *ETR Trip* and par. 1-24 *Motor current*,  $I_{M,N}$  is set to the rated motor current (see motor name plate).

□ **Installation of Brake Cable**

(Only for frequency converters ordered with brake chopper option).

The connection cable to the brake resistor must be screened.

1. Connect the screen by means of cable clamps to the conductive back plate on the frequency converter and to the metal cabinet of the brake resistor.
2. Size the brake cable cross-section to match the brake torque.

No.	Function
81, 82	Brake resistor terminals

See Brake instructions, MI.90.FX.YY and MI.50.SX.YY for more information about safe installation.



**NB!:**

Voltages up to 960 V DC, depending on the supply voltage, may occur on the terminals.

□ **RS 485 Bus Connection**

One or more frequency converters can be connected to a control (or master) using the RS485 standardized interface. Terminal 68 is connected to the P signal (TX+, RX+), while terminal 69 is connected to the N signal (TX-, RX-).

If more than one frequency converter is connected to a master, use parallel connections.

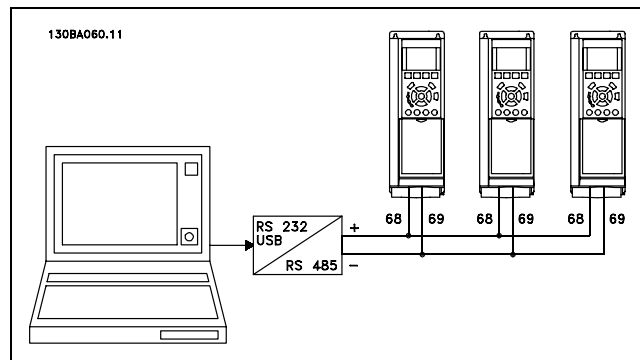

— How to Install —

In order to avoid potential equalizing currents in the screen, earth the cable screen via terminal 61, which is connected to the frame via an RC-link.

**Bus termination**

The RS485 bus must be terminated by a resistor network at both ends. For this purpose, set switch S801 on the control card for "ON".

For more information, see the paragraph *Switches S201, S202, and S801*.



**NB!:**

Communication protocol must be set to FC MC par. 8-30.

□ **How to Connect a PC to the FC 300**

To control the frequency converter from a PC, install the MCT 10 Set-up Software. The PC is connected via a standard (host/device) USB cable, or via the RS485 interface as shown in the section *Bus Connection* in the chapter *How to Programme*.



**NB!:**

The earth terminal to motor and shield on the USB connector do NOT have the same potential. Use isolated laptops in conjunction with the USB port.

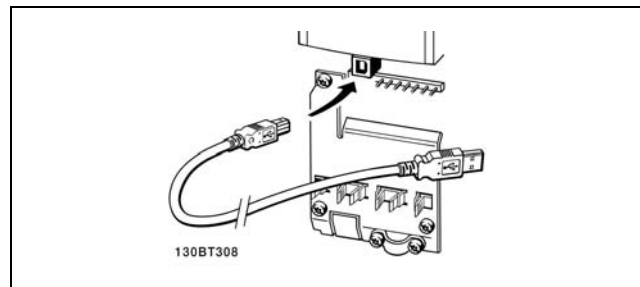

USB connection.

□ **The FC 300 Software Dialog**

**Data storage in PC via MCT 10 Set-Up Software:**

1. Connect a PC to the unit via USB com port
2. Open MCT 10 Set-up Software
3. Choose "Read from drive"
4. Choose "Save as"

All parameters are now stored.

**Data transfer from PC to drive via MCT 10 Set-Up Software:**

1. Connect a PC to the unit via USB com port
2. Open MCT 10 Set-up software
3. Choose "Open" – stored files will be shown
4. Open the appropriate file
5. Choose "Write to drive"

All parameters are now transferred to the drive.

A separate manual for MCT 10 Set-up Software is available.

## — How to Install —

### □ High Voltage Test

Carry out a high voltage test by short-circuiting terminals U, V, W, L<sub>1</sub>, L<sub>2</sub> and L<sub>3</sub>. Energize by max. 2.15 kV DC for one second between this short-circuit and the chassis.



#### **NB!:**

When running high voltage tests of the entire installation, interrupt the mains and motor connection if the leakage currents are too high.

### □ Safety Eart Connection

The frequency converter has a high leakage current and must be earthed appropriately for safety reasons according to EN 50178.



The earth leakage current from the frequency converter exceeds 3.5 mA. To ensure a good mechanical connection from the earth cable to the earth connection (terminal 95), the cable cross-section must be at least 10 mm<sup>2</sup> or 2 rated earth wires terminated separately.

### □ Electrical Installation - EMC Precautions

The following is a guideline to good engineering practice when installing frequency converters. Follow these guidelines to comply with EN 61800-3 *First environment*. If the installation is in EN 61800-3 *Second environment*, i.e. industrial networks, or in an installation with its own transformer, deviation from these guidelines is allowed but not recommended. See also paragraphs *CE Labelling*, *General Aspects of EMC Emission* and *EMC Test Results*.

#### **Good engineering practice to ensure EMC-correct electrical installation:**

- Use only braided screened/armoured motor cables and braided screened/armoured control cables. The screen should provide a minimum coverage of 80%. The screen material must be metal, not limited to but typically copper, aluminium, steel or lead. There are no special requirements for the mains cable.
- Installations using rigid metal conduits are not required to use screened cable, but the motor cable must be installed in conduit separate from the control and mains cables. Full connection of the conduit from the drive to the motor is required. The EMC performance of flexible conduits varies a lot and information from the manufacturer must be obtained.
- Connect the screen/armour/conduit to earth at both ends for motor cables as well as for control cables. In some cases, it is not possible to connect the screen in both ends. If so, connect the screen at the frequency converter. See also *Earthing of Braided Screened/Armoured Control Cables*.
- Avoid terminating the screen/armour with twisted ends (pigtailed). It increases the high frequency impedance of the screen, which reduces its effectiveness at high frequencies. Use low impedance cable clamps or EMC cable glands instead.
- Avoid using unscreened/unarmoured motor or control cables inside cabinets housing the drive(s), whenever this can be avoided.

Leave the screen as close to the connectors as possible.

The illustration shows an example of an EMC-correct electrical installation of an IP 20 frequency converter. The frequency converter is fitted in an installation cabinet with an output contactor and connected to a PLC, which is installed in a separate cabinet. Other ways of doing the installation may have just as good an EMC performance, provided the above guide lines to engineering practice are followed.

If the installation is not carried out according to the guideline and if unscreened cables and control wires are used, some emission requirements are not complied with, although the immunity requirements are fulfilled. See the paragraph *EMC test results*.



— How to Install —

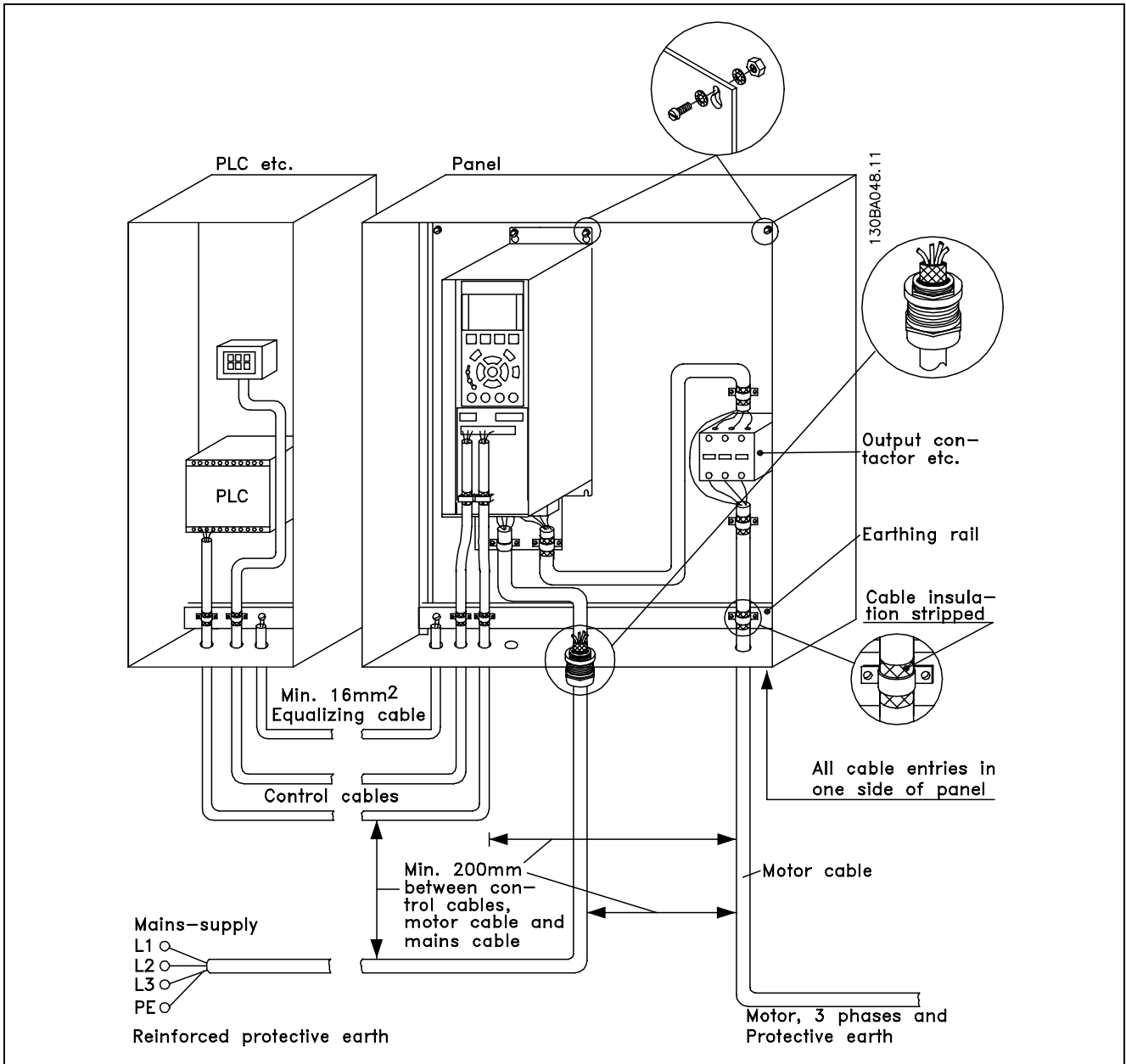

EMC-correct electrical installation of an IP20 frequency converter.

— How to Install —

□ **Use of EMC-Correct Cables**

Danfoss recommends braided screened/armoured cables to optimise EMC immunity of the control cables and the EMC emission from the motor cables.

The ability of a cable to reduce the in- and outgoing radiation of electric noise depends on the transfer impedance ( $Z_T$ ). The screen of a cable is normally designed to reduce the transfer of electric noise; however, a screen with a lower transfer impedance ( $Z_T$ ) value is more effective than a screen with a higher transfer impedance ( $Z_T$ ).

Transfer impedance ( $Z_T$ ) is rarely stated by cable manufacturers but it is often possible to estimate transfer impedance ( $Z_T$ ) by assessing the physical design of the cable.

Transfer impedance ( $Z_T$ ) can be assessed on the basis of the following factors:

- The conductivity of the screen material.
- The contact resistance between the individual screen conductors.
- The screen coverage, i.e. the physical area of the cable covered by the screen
  - often stated as a percentage value.
- Screen type, i.e. braided or twisted pattern.

- a. Aluminium-clad with copper wire.
- b. Twisted copper wire or armoured steel wire cable.
- c. Single-layer braided copper wire with varying percentage screen coverage. This is the typical Danfoss reference cable.
- d. Double-layer braided copper wire.
- e. Twin layer of braided copper wire with a magnetic, screened/armoured intermediate layer.
- f. Cable that runs in copper tube or steel tube.
- g. Lead cable with 1.1 mm wall thickness.

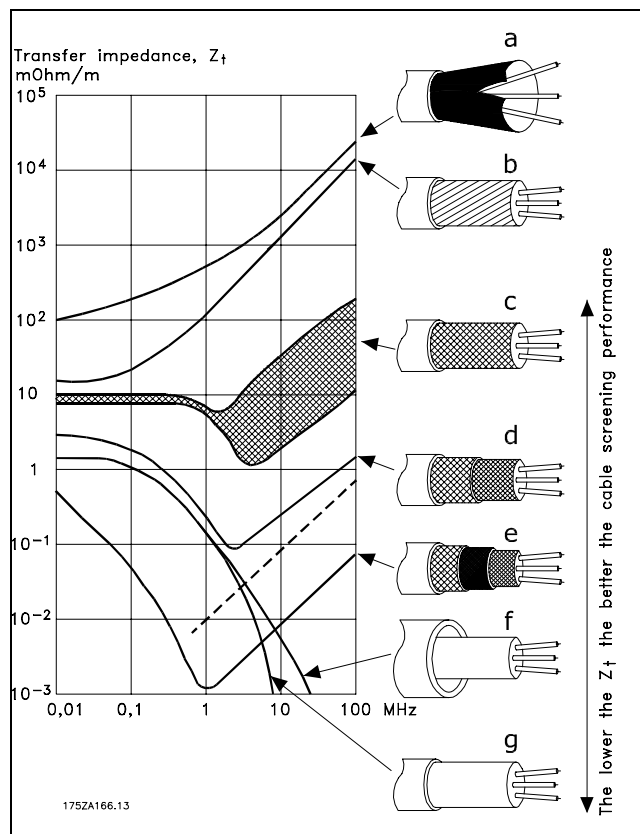

— How to Install —

□ **Earthing of Screened/Armoured Control Cables**

Generally speaking, control cables must be braided screened/armoured and the screen must be connected by means of a cable clamp at both ends to the metal cabinet of the unit.

The drawing below indicates how correct earthing is carried out and what to do if in doubt.

a. **Correct earthing**

Control cables and cables for serial communication must be fitted with cable clamps at both ends to ensure the best possible electrical contact.

b. **Wrong earthing**

Do not use twisted cable ends (pigtailed). They increase the screen impedance at high frequencies.

c. **Protection with respect to earth potential between PLC and VLT**

If the earth potential between the frequency converter and the PLC (etc.) is different, electric noise may occur that will disturb the entire system. Solve this problem by fitting an equalising cable, next to the control cable. Minimum cable cross-section: 16 mm<sup>2</sup>.

d. **For 50/60 Hz earth loops**

If very long control cables are used, 50/60 Hz earth loops may occur. Solve this problem by connecting one end of the screen to earth via a 100nF capacitor (keeping leads short).

e. **Cables for serial communication**

Eliminate low-frequency noise currents between two frequency converters by connecting one end of the screen to terminal 61. This terminal is connected to earth via an internal RC link. Use twisted-pair cables to reduce the differential mode interference between the conductors.

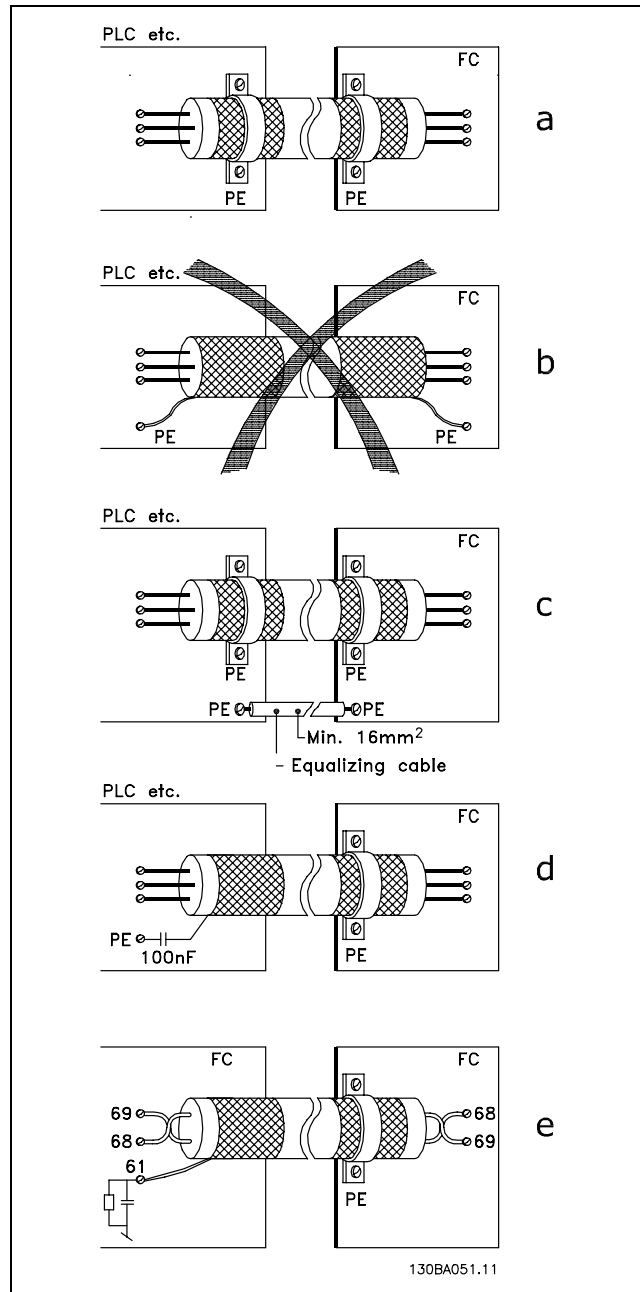

130BA051.11

— How to Install —

□ **Mains Supply Interference/Harmonics**

A frequency converter takes up a non-sinusoidal current from mains, which increases the input current  $I_{RMS}$ . A non-sinusoidal current is transformed by means of a Fourier analysis and split up into sine wave currents with different frequencies, i.e. different harmonic currents  $I_N$  with 50 Hz as the basic frequency:

Harmonic currents	$I_1$	$I_5$	$I_7$
Hz	50 Hz	250 Hz	350 Hz

The harmonics do not affect the power consumption directly but increase the heat losses in the installation (transformer, cables). Consequently, in plants with a high percentage of rectifier load, maintain harmonic currents at a low level to avoid overload of the transformer and high temperature in the cables.

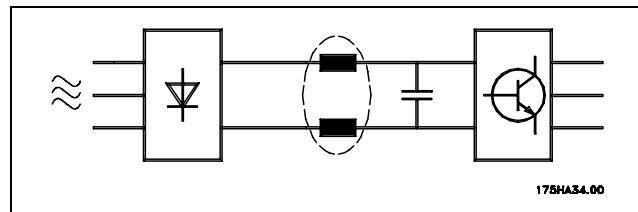

**NB!:**

Some of the harmonic currents might disturb communication equipment connected to the same transformer or cause resonance in connection with power-factor correction batteries.

Harmonic currents compared to the RMS input current:

	Input current
$I_{RMS}$	1.0
$I_1$	0.9
$I_5$	0.4
$I_7$	0.2
$I_{11-49}$	< 0.1

To ensure low harmonic currents, the frequency converter is equipped with intermediate circuit coils as standard. This normally reduces the input current  $I_{RMS}$  by 40%.

The voltage distortion on the mains supply depends on the size of the harmonic currents multiplied by the mains impedance for the frequency in question. The total voltage distortion THD is calculated on the basis of the individual voltage harmonics using this formula:

$$THD\% = \sqrt{U_5^2 + U_7^2 + \dots + U_N^2} \quad (U_N \text{ \% of } U)$$

□ **Residual Current Device**

You can use RCD relays, multiple protective earthing or earthing as extra protection, provided that local safety regulations are complied with.

If an earth fault appears, a DC content may develop in the faulty current.

If RCD relays are used, you must observe local regulations. Relays must be suitable for protection of 3-phase equipment with a bridge rectifier and for a brief discharge on power-up see section *Earth Leakage Current* for further information.

# Application Examples

**Start/Stop**

Terminal 18 = start/stop par. 5-10 [8] *Start*  
 Terminal 27 = No operation par. 5-12 [0] *No operation* (Default *coast inverse*)  
 Terminal 37 = Safe stop (FC 302 only)

Par. 5-10 *Digital Input* = *Start* (default)  
 Par. 5-12 *Digital Input* = *coast inverse* (default)

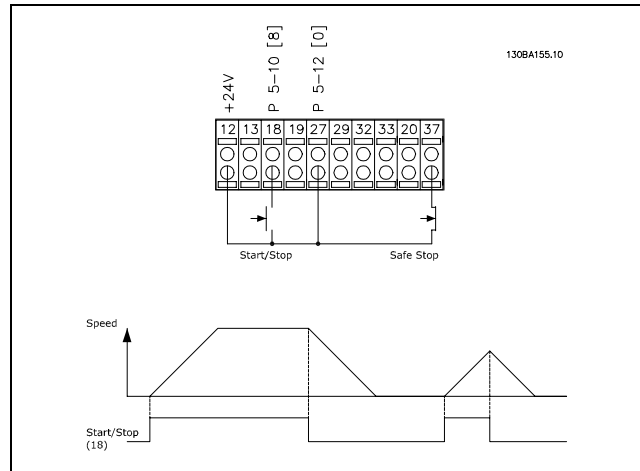

**Pulse Start/Stop**

Terminal 18 = start/stop par. 5-10 [9] *Latched start*  
 Terminal 27 = Stop par. 5-12 [6] *Stop inverse*  
 Terminal 37 = Coasting stop (safe)

Par. 5-10 *Digital Input* = *Latched start*  
 Par. 5-12 *Digital Input* = *Stop inverse*

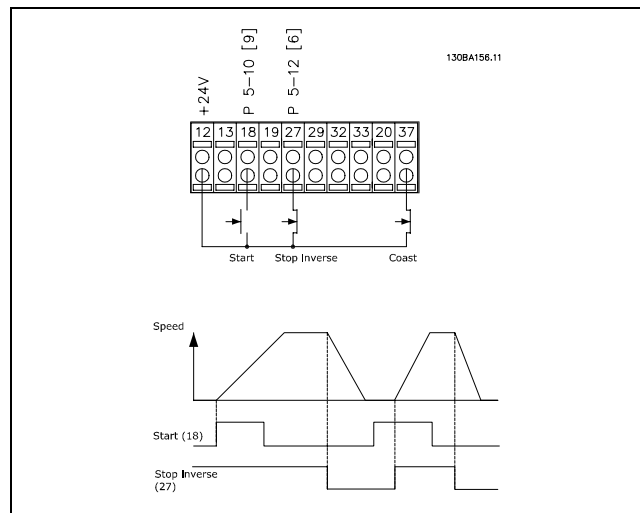

**Potentiometer Reference**

Voltage reference via a potentiometer.

Par. 3-15 *Reference Resource 1* [1] = *Analog Input 53*  
 Par. 6-10 *Terminal 53, Low Voltage* = 0 Volt  
 Par. 6-11 *Terminal 53, High Voltage* = 10 Volt  
 Par. 6-14 *Terminal 53, Low Ref./Feedb. Value* = 0 RPM  
 Par. 6-15 *Terminal 53, High Ref./Feedb. Value* = 1.500 RPM  
 Switch S201 = OFF (U)

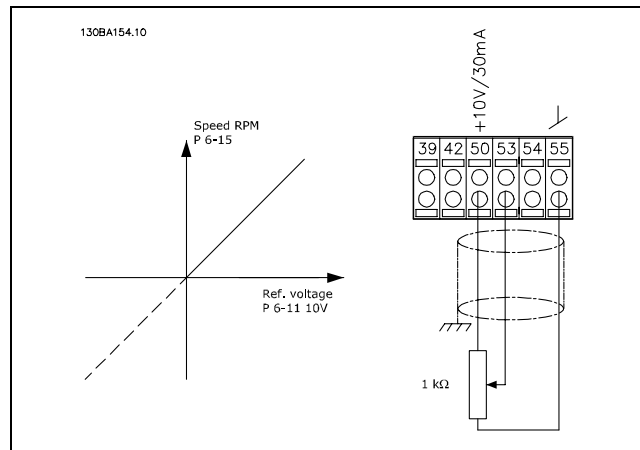

— Application Examples —

□ **Encoder Connection**

The purpose of this guideline is to ease the set-up of encoder connection to FC 302. Before setting up the encoder the basic settings for a closed loop speed control system will be shown.

**Encoder Connection to FC 302**

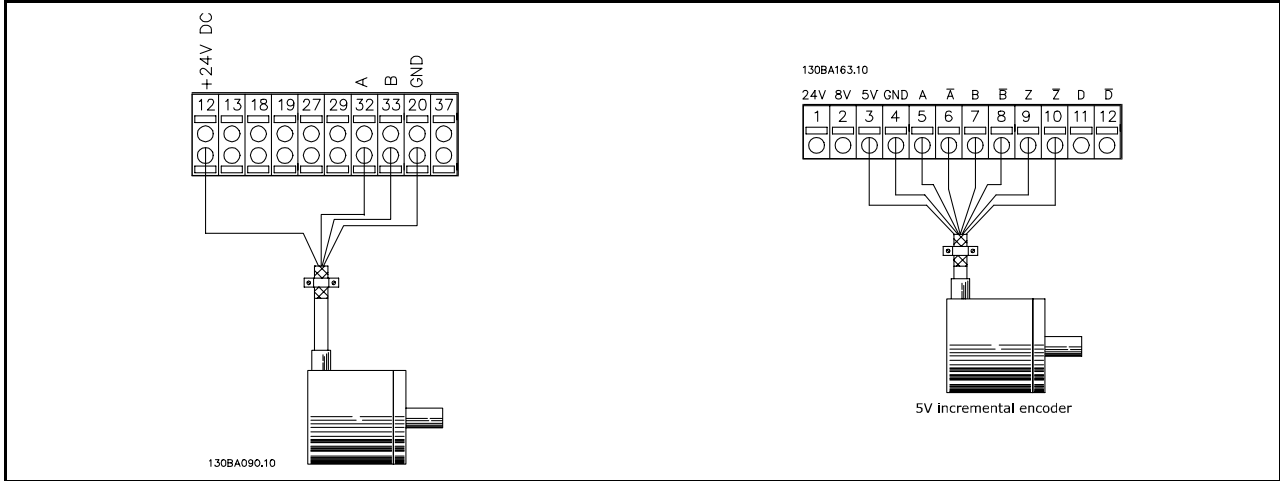

□ **Encoder Direction**

The direction of encoder is determined by which order the pulses are entering the drive. Clockwise direction means channel A is 90 electrical degrees before channel B. Counter Clockwise direction means channel B is 90 electrical degrees before A. The direction determined by looking into the shaft end.

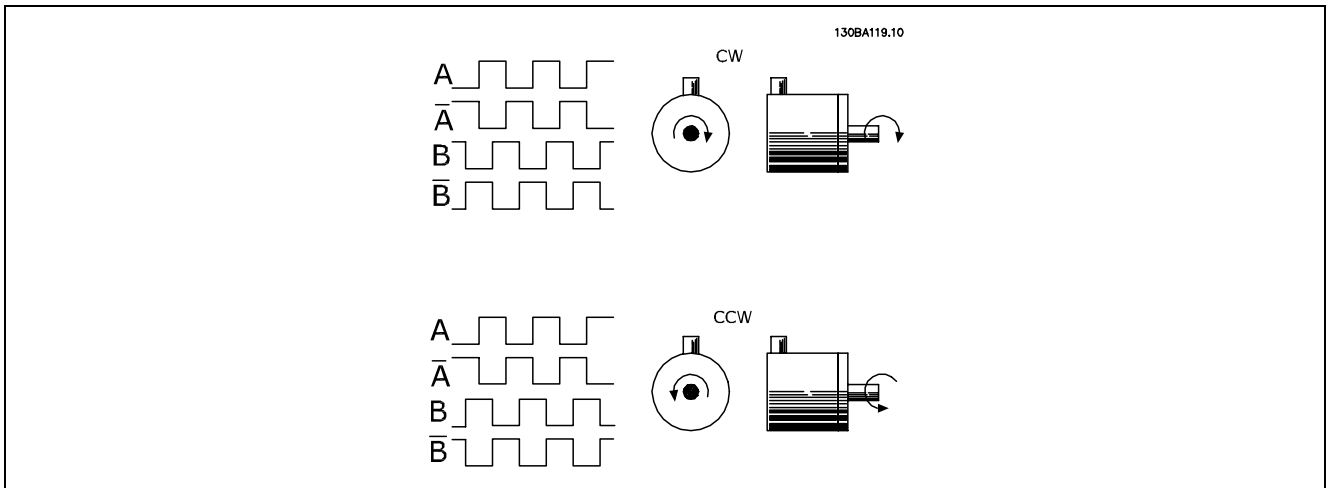

— Application Examples —

□ **Closed Loop Drive System**

A drive system consist usually of more elements as:

- Motor
- Add  
(Gearbox)
- (Mechanical Brake)
- FC 302 AutomationDrive
- Encoder as feed-back system
- Brake resistor for dynamic braking
- Transmission
- Load

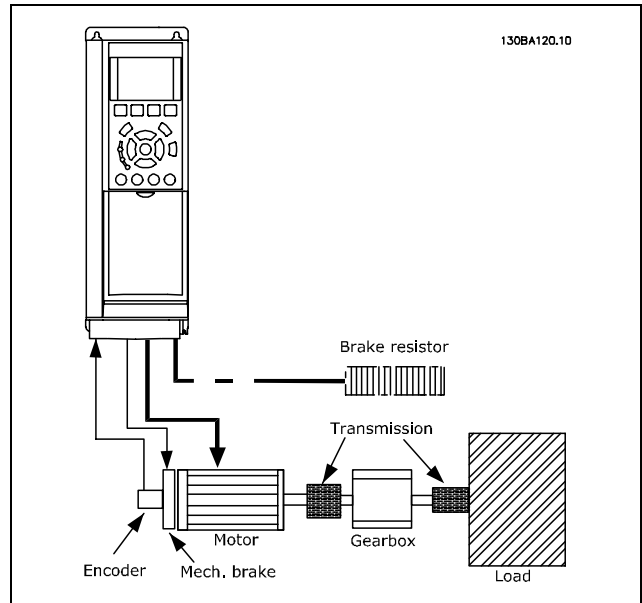

**Basic Set-up for FC 302 Closed Loop Speed Control**

Applications demanding mechanical brake control will usually need a brake resistor.

— Application Examples —

□ **Programming of Torque Limit and Stop**

In applications with an external electro-mechanical brake, such as hoisting applications, it is possible to stop the frequency converter via a 'standard' stop command and simultaneously activate the external electro-mechanical brake.

The example given below illustrates the programming of frequency converter connections.

The external brake can be connected to relay 1 or 2, see paragraph *Control of Mechanical Brake*.

Program terminal 27 to Coast, inverse [2] or Coast and Reset, inverse [3], and program terminal 29 to Terminal mode 29 Output [1] and Torque limit & stop [27].

Description:

If a stop command is active via terminal 18 and the frequency converter is not at the torque limit, the motor ramps down to 0 Hz.

If the frequency converter is at the torque limit and a stop command is activated, terminal 29 Output (programmed to Torque limit and stop [27]) is activated. The signal to terminal 27 I changes from 'logic 1' to 'logic 0', and the motor starts to coast, thereby ensuring that the hoist stops even if the frequency converter itself cannot handle the required torque (i.e. due to excessive overload).

- Start/stop via terminal 18  
Par. 5-10 Start [8]
- Quickstop via terminal 27  
Par. 5-12 Coasting Stop, Inverse [2]
- Terminal 29 Output  
Par. 5-02 Terminal 29 Mode Output [1]  
Par. 5-31 Torque Limit & Stop [27]
- Relay output [0] (Relay 1)  
Par. 5-40 Mechanical Brake Control [32]

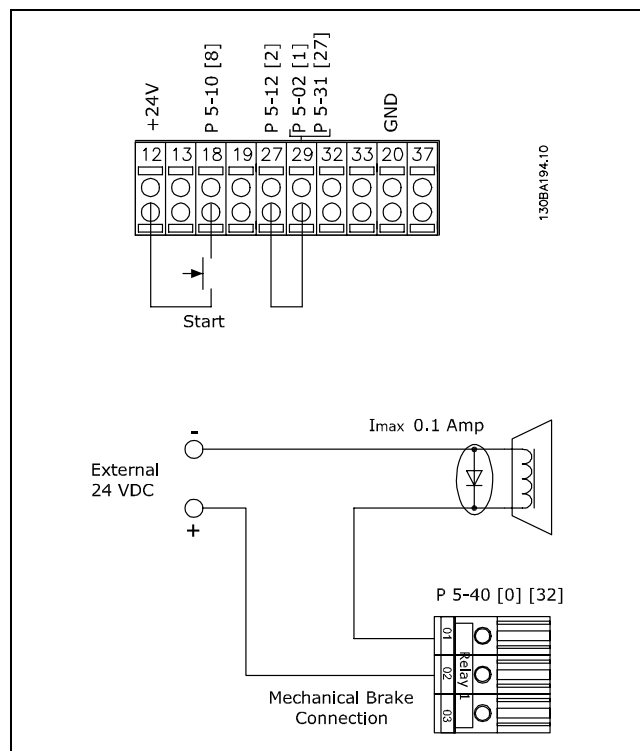



## — Application Examples —

**□ Automatic Motor Adaptation (AMA)**

AMA is an algorithm to measure the electrical motor parameters on a motor at standstill.

This means that AMA itself does not supply any torque.

AMA is useful when commissioning systems and optimising the adjustment of the frequency converter to the applied motor. This feature is particularly used where the default setting does not apply to the connected motor.

Par. 1-29 allows a choice of complete AMA with determination of all electrical motor parameters or reduced AMA with determination of the stator resistance  $R_s$  only.

The duration of a total AMA varies from a few minutes on small motors to more than 15 minutes on large motors.

**Limitations and preconditions:**

- For the AMA to determine the motor parameters optimally, enter the correct motor nameplate data in par. 1-20 to 1-26.
- For the best adjustment of the frequency converter, carry out AMA on a cold motor. Repeated AMA runs may lead to a heating of the motor, which results in an increase of the stator resistance,  $R_s$ . Normally, this is not critical.
- AMA can only be carried out if the rated motor current is minimum 35% of the rated output current of the frequency converter. AMA can be carried out on up to one oversize motor.
- It is possible to carry out a reduced AMA test with an LC filter installed. Avoid carrying out a complete AMA with an LC filter. If an overall setting is required, remove the LC filter while running a total AMA. After completion of the AMA, reinsert the LC filter.
- If motors are coupled in parallel, use only reduced AMA if any.
- Avoid running a complete AMA when using synchronous motors. If synchronous motors are applied, run a reduced AMA and manually set the extended motor data. The AMA function does not apply to permanent magnet motors.
- The frequency converter does not produce motor torque during an AMA. During an AMA, it is imperative that the application does not force the motor shaft to run, which is known to happen with e.g. wind milling in ventilation systems. This disturbs the AMA function.

## — Application Examples —

### □ Smart Logic Control Programming

A new useful facility in FC 302 is the Smart Logic Control (SLC).

In applications where a PLC is generating a simple sequence the SLC may take over elementary tasks from the main control.

SLC is designed to act from event sent to or generated in the FC 302. The frequency converter will then perform the pre-programmed action.

### □ SLC Application Example

One sequence 1:

Start – ramp up – run at reference speed 2 sec – ramp down and hold shaft until stop.

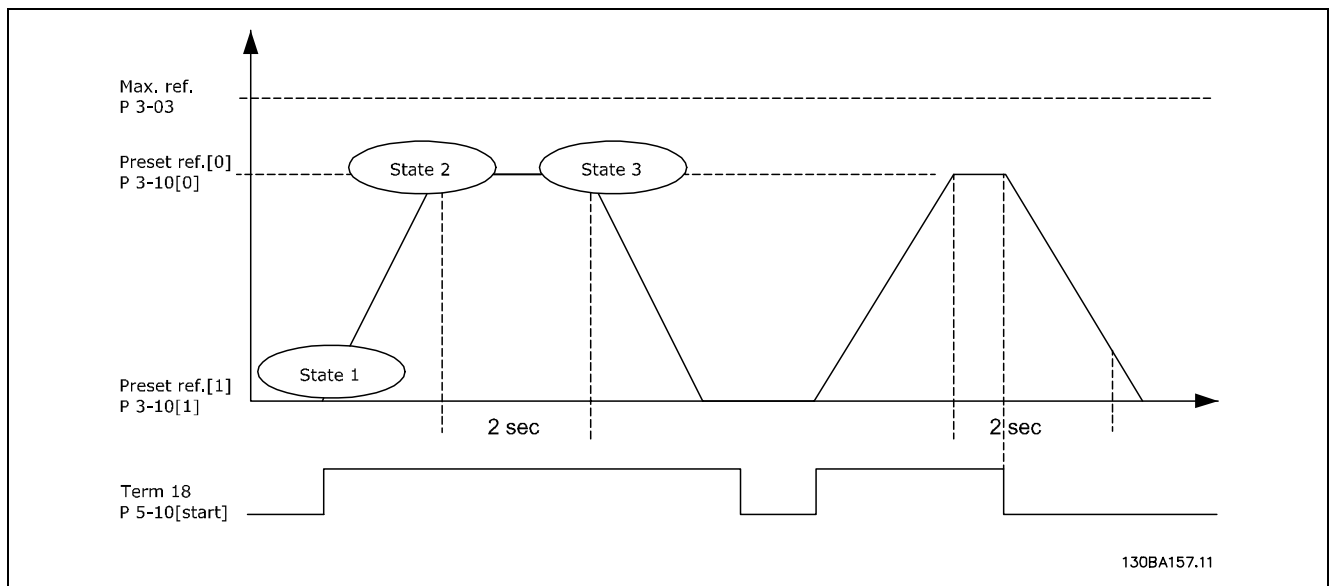

Set the ramping times in par. 3-41 and 3-42 to the wanted times

$$t_{ramp} = \frac{t_{acc} * n_{norm}[par.1-25]}{\Delta ref[RPM]}$$

Set term 27 to *No Operation* (par. 5-12)

Set Preset reference 0 to first preset speed (par. 3-10 [0]) in percentage of Max reference speed (par. 3-03). Ex.: 60%

Set preset reference 1 to second preset speed (par. 3-10 [1] Ex.: 0 % (zero).

Set the timer 0 for constant running speed in par. 13-20 [0]. Ex.: 2 sec.

Set Event 1 in par. 13-51 [1] to *True* [1]

Set Event 2 in par. 13-51 [2] to *On Reference* [4]

Set Event 3 in par. 13-51 [3] to *Time Out 0* [30]

Set Event 4 in par. 13-51 [1] to *False* [0]

Set Action 1 in par. 13-52 [1] to *Select preset 0* [10]

Set Action 2 in par. 13-52 [2] to *Start Timer 0* [29]

Set Action 3 in par. 13-52 [3] to *Select preset 1* [11]

Set Action 4 in par. 13-52 [4] to *No Action* [1]

— Application Examples —

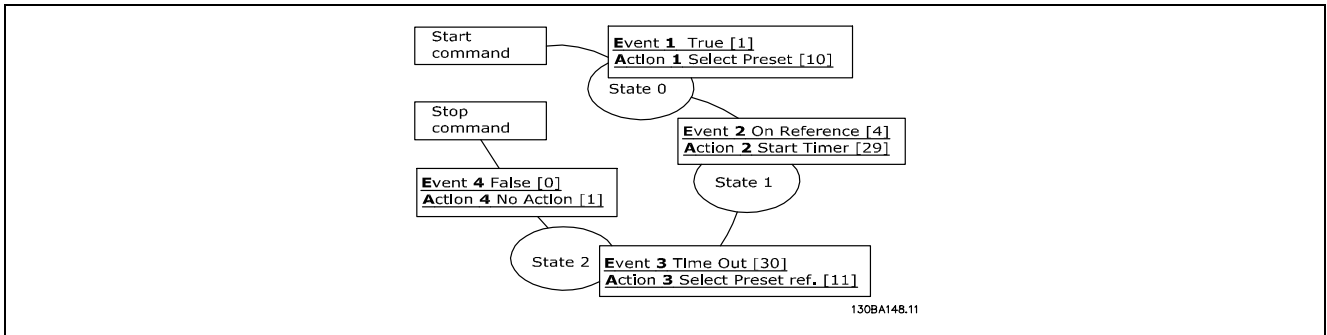

Set the Smart Logic Control in par. 13-00 to ON.

Start / stop command is applied on terminal 18. If stop signal is applied the frequency converter will ramp down and go into free mode.

— Application Examples —

# How to Programme

## □ The Graphical and Numerical FC 300 Local

### □ How to Programme on the Graphical Local Control Panel

The following instructions are valid for the graphical LCP (LCP 102):

The control panel is divided into four functional groups:

1. Graphical display with Status lines.
2. Menu keys and indicator lights - changing parameters and switching between display functions.
3. Navigation keys and indicator lights (LEDs).
4. Operation keys and indicator lights (LEDs).

All data is displayed in a graphical LCP display, which can show up to five items of operating data while displaying [Status].

#### Display lines:

- a. **Status line:** Status messages displaying icons and graphic.
- b. **Line 1-2:** Operator data lines displaying data defined or chosen by the user. By pressing the [Status] key, up to one extra line can be added.
- c. **Status line:** Status messages displaying text.

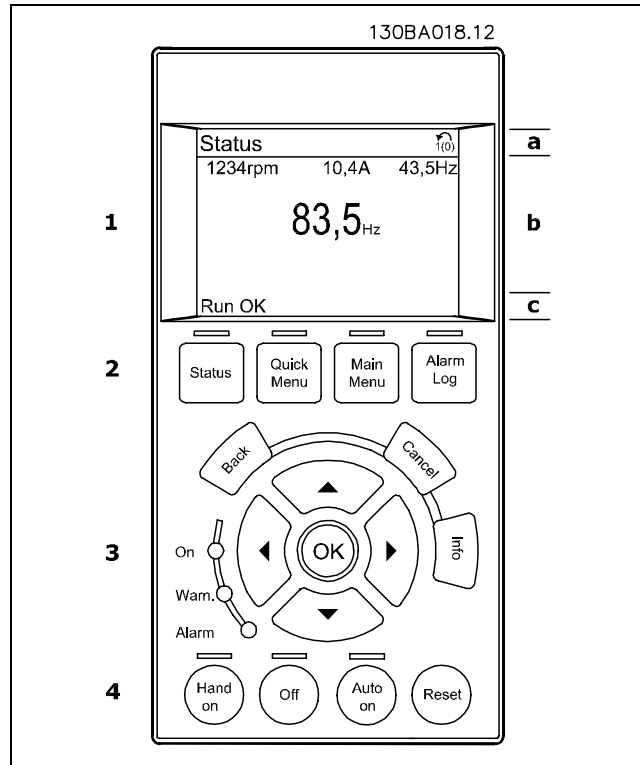

The LCD-display has back light and a total of 6 alpha-numeric lines. The display lines show the direction of rotation (arrow), the chosen Set-up as well as the programming Set-up. The display is divided into 3 sections:

**Top section** shows up to 2 measurements in normal operating status.

The top line in the **Middle section** shows up to 5 measurements with related unit, regardless of status (except in the case of alarm/warning).

**Bottom section** always shows the state of the frequency converter in Status mode.

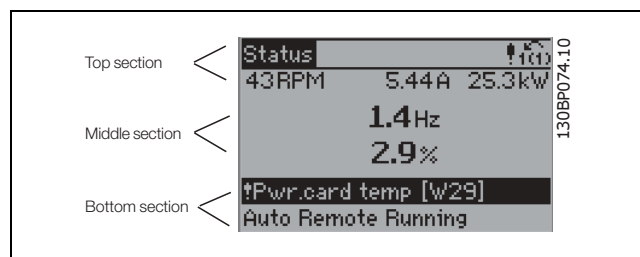

The Active Set-up (selected as the Active Set-up in par. 0-10) is shown. When programming another Set-up than the Active Set-up, the number of the programmed Set-up appears to the right.

## — How to Programme —

### Display Contrast Adjustment

Press [status] and [▲] for darker display

Press [status] and [▼] for brighter display

Most FC 300 parameter set-ups can be changed immediately via the control panel, unless a password has been created via par. 0-60 *Main Menu Password* or via par. 0-65 *Quick Menu Password*.

### Indicator lights (LEDs):

If certain threshold values are exceeded, the alarm and/or warning LED lights up. A status and alarm text appear on the control panel.

The on LED is activated when the frequency converter receives mains voltage or via a DC bus terminal or 24 V external supply. At the same time, the back light is on.

- Green LED/On: Control section is working.
- Yellow LED/Warn.: Indicates a warning.
- Flashing Red LED/Alarm: Indicates an alarm.



### LCP keys

The control keys are divided into functions. The keys below the display and indicator lamps are used for parameter Set-up, including choice of display indication during normal operation.

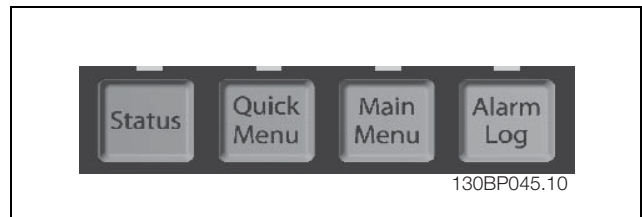

**[Status]** indicates the status of the frequency converter and/or the motor. You can choose between 3 different readouts by pressing the [Status] key:

5 line readouts, 4 line readouts or Smart Logic Control.

Use **[Status]** for selecting the mode of display or for changing back to Display mode from either the Quick Menu mode, the Main Menu mode or Alarm mode. Also use the [Status] key to toggle single or double read-out mode.

**[Quick Menu]** allows quick access to different Quick Menus such as:

- My Personal Menu
- Quick Set-up
- Changes Made
- Loggings

Use **[Quick Menu]** for programming the parameters belonging to the Quick Menu. It is possible to switch directly between Quick Menu mode and Main Menu mode.

**[Main Menu]** is used for programming all parameters.

It is possible to switch directly between Main Menu mode and Quick Menu mode.

Parameter shortcut can be carried out by pressing down the **[Main Menu]** key for 3 seconds.

The parameter shortcut allows direct access to any parameter.

## — How to Programme —

**[Alarm Log]** displays an Alarm list of the five latest alarms (numbered A1-A5). To obtain additional details about an alarm, use the arrow keys to manoeuvre to the alarm number and press [OK]. You will now receive information about the condition of your frequency converter right before entering the alarm mode.

**[Back]** takes you to the previous step or layer in the navigation structure.

**[Cancel]** annuls your last change or command as long as the display has not been changed.

**[Info]** supplies information about a command, parameter, or function in any display window. [Info] provides detailed information whenever help is needed.

Exit info mode by pressing either [Info], [Back], or [Cancel].



### Navigation Keys

The four navigation arrows are used to navigate between the different choices available in **[Quick Menu]**, **[Main Menu]** and **[Alarm Log]**. Use the keys to move the cursor.

**[OK]** is used for choosing a parameter marked by the cursor and for enabling the change of a parameter.

**Local Control Key** for local control are found at the bottom of the control panel.

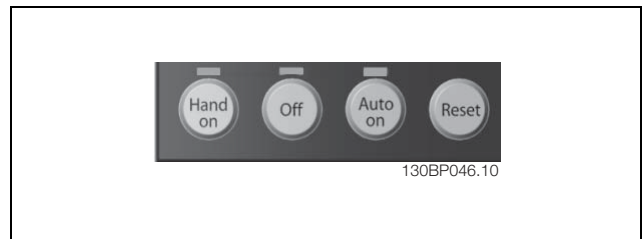

## — How to Programme —

**[Hand On]** enables control of the frequency converter via the LCP. [Hand on] also starts the motor, and it is now possible to enter the motor speed data by means of the arrow keys. The key can be selected as Enable [1] or Disable [0] via par. 0-40 *[Hand on] key on LCP*.

External stop signals activated by means of control signals or a serial bus will override a "start" command via the LCP.

The following control signals will still be active when [Hand on] is activated:

- [Hand on] - [Off] - [Auto on]
- Reset
- Coasting stop inverse
- Reversing
- Set-up select lsb - Set-up select msb
- Stop command from serial communication
- Quick stop
- DC brake

**[Off]** stops the connected motor. The key can be selected as Enable [1] or Disable [0] via par. 0-41 *[Off] key on LCP*. If no external stop function is selected and the [Off] key is inactive the motor can be stopped by disconnecting the voltage.

**[Auto On]** enables the frequency converter is to be controlled via the control terminals and/or serial communication. When a start signal is applied on the control terminals and/or the bus, the frequency converter will start. The key can be selected as Enable [1] or Disable [0] via par. 0-42 *[Auto on] key on LCP*.



**NB!:**

An active HAND-OFF-AUTO signal via the digital inputs has higher priority than the control keys [Hand on] – [Auto on].

**[Reset]** is used for resetting the frequency converter after an alarm (trip). It can be selected as *Enable* [1] or *Disable* [0] via par. 0-43 *Reset Keys on LCP*.

**The parameter shortcut** can be carried out by holding down the [Main Menu] key for 3 seconds. The parameter shortcut allows direct access to any parameter.



— How to Programme —

□ **Quick Transfer of Parameter Settings**

Once the set-up of a drive is complete, we recommend that you store the data in the LCP or on a PC via MCT 10 Set-up Software Tool.

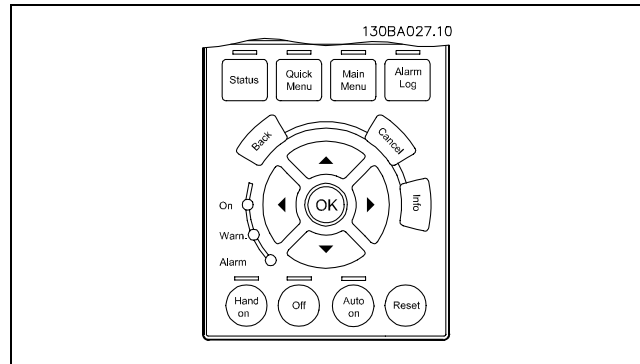

**Data storage in LCP:**

1. Go to par. 0-50 *LCP Copy*
2. Press the [OK] key
3. Select "All to LCP"
4. Press the [OK] key

All parameter settings are now stored in the LCP indicated by the progress bar. When 100% is reached, press [OK].



**NB!:**  
Stop the motor before performing this operation.

You can now connect the LCP to another frequency converter and copy the parameter settings to this frequency converter as well.

**Data transfer from LCP to drive:**

1. Go to par. 0-50 *LCP Copy*
2. Press the [OK] key
3. Select "All from LCP"
4. Press the [OK] key

The parameter settings stored in the LCP are now transferred to the drive indicated by the progress bar. When 100% is reached, press [OK].



**NB!:**  
Stop the motor before performing this operation.

— How to Programme —

□ **Display Mode**

In normal operation, up to 5 different operating variables can be indicated continuously in the middle section: 1.1, 1.2, and 1.3 as well as 2 and 3.

□ **Display Mode - Selection of Read-Outs**

It is possible to toggle between three status read-out screens by pressing the [Status] key. Operating variables with different formatting are shown in each status screen - see below.

The table shows the measurements you can link to each of the operating variables. Define the links via par. 0-20, 0-21, 0-22, 0-23, and 0-24.

Each readout parameter selected in par. 0-20 to par. 0-24 has its own scale and digits after a possible decimal point. By larger numeric value of a parameter fewer digits are displayed after the decimal point.

Ex.: Current readout  
5.25 A; 15.2 A 105 A.

Operating variable:	Unit:
Par. 16-00 Control Word	hex
Par. 16-01 Reference	[unit]
Par. 16-02 Reference	%
Par. 16-03 Status Word	hex
Par. 16-05 Main Actual Value	%
Par. 16-10 Power	[kW]
Par. 16-11 Power	[HP]
Par. 16-12 Motor Voltage	[V]
Par. 16-13 Frequency	[Hz]
Par. 16-14 Motor Current	[A]
Par. 16-16 Torque	Nm
Par. 16-17 Speed	[RPM]
Par. 16-18 Motor Thermal	%
Par. 16-20 Motor Angle	
Par. 16-30 DC Link Voltage	V
Par. 16-32 Brake Energy / s	kW
Par. 16-33 Brake Energy / 2 min	kW
Par. 16-34 Heatsink Temp.	C
Par. 16-35 Inverter Thermal	%
Par. 16-36 Inv. Nom. Current	A
Par. 16-37 Inv. Max. Current	A
Par. 16-38 SL Control State	
Par. 16-39 Control Card Temp.	C
Par. 16-40 Loading Buffer Full	
Par. 16-50 External Reference	
Par. 16-51 Pulse Reference	
Par. 16-52 Feedback	[Unit]
Par. 16-53 Digi Pot Reference	
Par. 16-60 Digital Input	bin
Par. 16-61 Terminal 53 Switch Setting	V
Par. 16-62 Analog Input 53	
Par. 16-63 Terminal 54 Switch Setting	V
Par. 16-64 Analog Input 54	
Par. 16-65 Analog Output 42	[mA]
Par. 16-66 Digital Output	[bin]
Par. 16-67 Freq. Input #29	[Hz]
Par. 16-68 Freq. Input #33	[Hz]
Par. 16-69 Pulse Output #27	[Hz]
Par. 16-70 Pulse Output #29	[Hz]
Par. 16-71 Relay Output	
Par. 16-72 Counter A	
Par. 16-73 Counter B	
Par. 16-80 Fieldbus CTW	hex
Par. 16-82 Fieldbus REF 1	hex
Par. 16-84 Comm. Option STW	hex
Par. 16-85 FC Port CTW 1	hex
Par. 16-86 FC Port REF 1	hex
Par. 16-90 Alarm Word	
Par. 16-92 Warning Word	
Par. 16-94 Ext. Status Word	

**Status screen I:**

This read-out state is standard after start-up or initialization.

Use [INFO] to obtain information about the measurement links to the displayed operating variables (1.1, 1.2, 1.3, 2, and 3).

See the operating variables shown in the screen in this illustration.

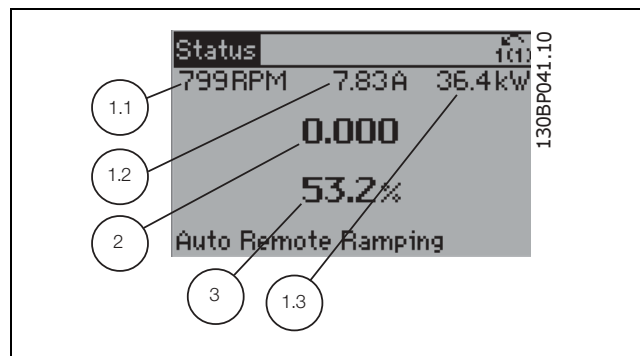

— How to Programme —

**Status screen II:**

See the operating variables (1.1, 1.2, 1.3, and 2) shown in the screen in this illustration.

In the example, Speed, Motor current, Motor power and Frequency are selected as variables in the first and second.

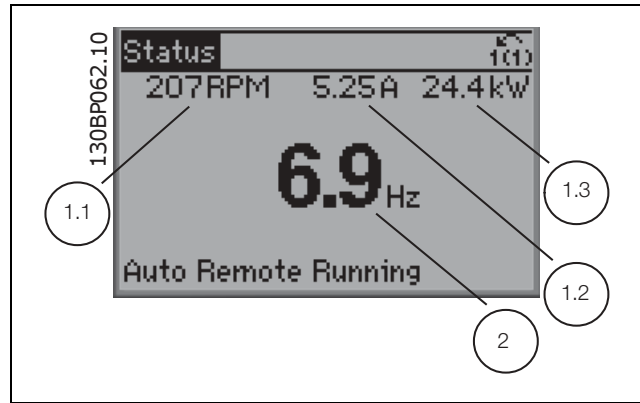

**Status screen III:**

This state displays the event and action of the Smart Logic Control. For further information, see section *Smart Logic Control*.

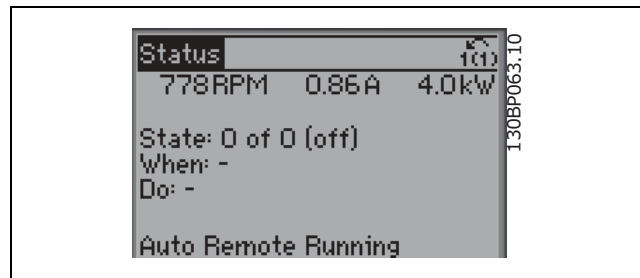

□ **Parameter Set-Up**

The FC 300 Series can be used for practically all assignments, which is why the number of parameters is quite large. The series offers a choice between two programming modes - a Main Menu and a Quick Menu mode. The former provides access to all parameters. The latter takes the user through a few parameters making it possible to start operating the frequency converter.

Regardless of the mode of programming, you can change a parameter both in the Main Menu mode and in the Quick Menu mode.

□ **Quick Menu Key Functions**

Pressing [Quick Menus] The list indicates the different areas contained in the Quick menu. Select *My Personal Menu* to display the chosen personal parameters. These parameters are selected in par. 0-25 *Personal Menu*. Up to 20 different parameters can be added in this menu.

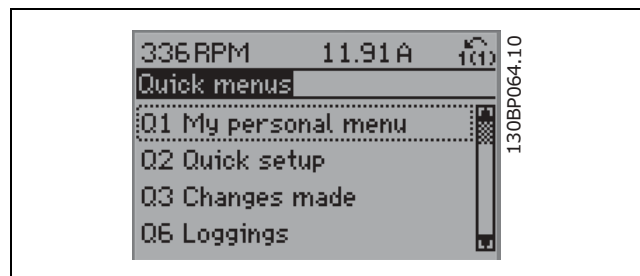

Select *Quick setup* to go through a limited amount of parameters to get the motor running almost optimally. The default setting for the other parameters considers the desired control functions and the configuration of signal inputs/outputs (control terminals).

The selection of parameter is effected by means of the arrow keys. The parameters in the following table are accessible.

— How to Programme —

Parameter	Designation	Setting
0-01	Language	
1-20	Motor Power	[kW]
1-22	Motor Voltage	[V]
1-23	Motor Frequency	[Hz]
1-24	Motor Current	[A]
1-25	Motor Nominal Speed	[rpm]
5-12	Terminal 27 Digital Input	[0] No function*
3-02	Min Reference	[rpm]
3-03	Max Reference	[rpm]
3-41	Ramp 1 Ramp-up Time	[sec]
3-42	Ramp 1 Ramp-down Time	[sec]
3-13	Reference Site	
1-29	Automatic Motor Adaptation (AMA)	[1] Enable complete AMA

\* If no connection in terminal 27 is selected no connection to +24 V on terminal 27 necessary.

Select *Changes made* to get information about:

- the last 10 changes. Use the up/down navigation keys to scroll between the last 10 changed parameters.
- the changes made since default setting.

Select *Loggings* to get information about the display line read-outs. The information is shown as graphs. Only display parameters selected in par. 0-20 and par. 0-24 can be viewed. It is possible to store up to 120 samples in the memory for later reference.

□ **Main Menu Mode**

Start the Main Menu mode is by pressing the [Main Menu] key. The read-out shown to the right appears on the display.

The middle and bottom sections on the display show a list of parameter groups which can be chosen by toggling the up and down buttons.

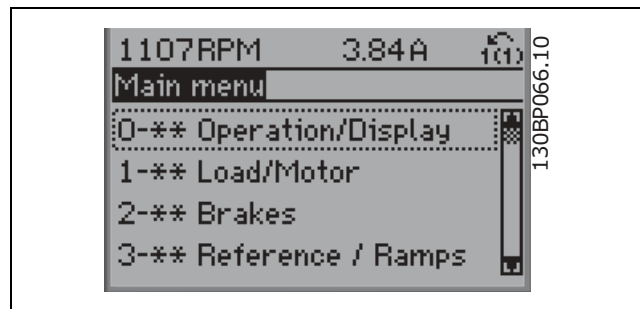

Each parameter has a name and number which remain the same regardless of the programming mode. In the Main Menu mode, the parameters are divided into groups. The first digit of the parameter number (from the left) indicates the parameter group number.

All parameters can be changed in the Main Menu. However, depending on the choice of configuration (par. 1-00), some parameters can be "missing". E.g. open loop hides all the PID parameters, and other enabled options make more parameter groups visible.

— How to Programme —

□ **Parameter Selection**

In the Main menu mode, the parameters are divided into groups. You select a parameter group by means of the navigation keys.

The following parameter groups are accessible:

Group no.	Parameter group:
0	Operation/Display
1	Load/Motor
2	Brakes
3	References/Ramps
4	Limits/Warnings
5	Digital In/Out
6	Analog In/Out
7	Controls
8	Comm. and Options
9	Profibus
10	CAN Fieldbus
11	Reserved Com. 1
12	Reserved Com. 2
13	Smart Logic
14	Special Functions
15	Drive Information
16	Data Readouts
17	Motor Feedb. Option

After selecting a parameter group, choose a parameter by means of the navigation keys. The middle section on the display shows the parameter number and name as well as the selected parameter value.

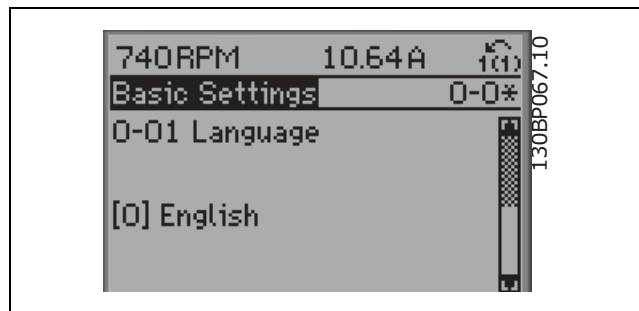

□ **Changing Data**

The procedure for changing data is the same whether you select a parameter in the Quick menu or the Main menu mode. Press [OK] to change the selected parameter.

The procedure for changing data depends on whether the selected parameter represents a numerical data value or a text value.

□ **Changing a Text Value**

If the selected parameter is a text value, change the text value by means of the up/down navigation keys. The up key increases the value, and the down key decreases the value. Place the cursor on the value you want to save and press [OK].

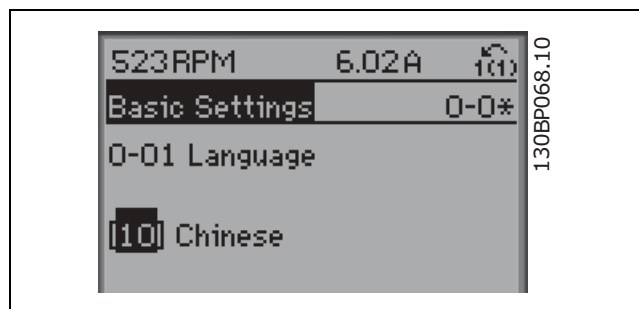

— How to Programme —

□ **Changing a Group of Numeric Data Values**

If the chosen parameter represents a numeric data value, change the chosen data value by means of the <> navigation keys as well as the up/down navigation keys. Use the <> navigation keys to move the cursor horizontally.

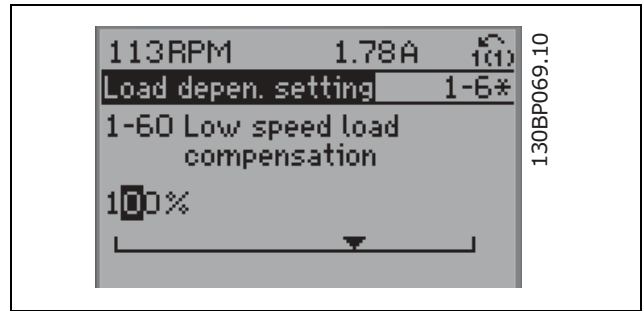

Use the up/down navigation keys to change the data value. The up key enlarges the data value, and the down key reduces the data value. Place the cursor on the value you want to save and press [OK].

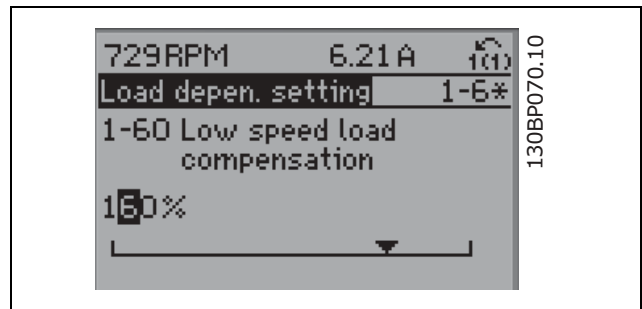

□ **Infinitely Variable Change of Numeric Data Value**

If the chosen parameter represents a numeric data value, select a digit by means of the <> navigation keys.

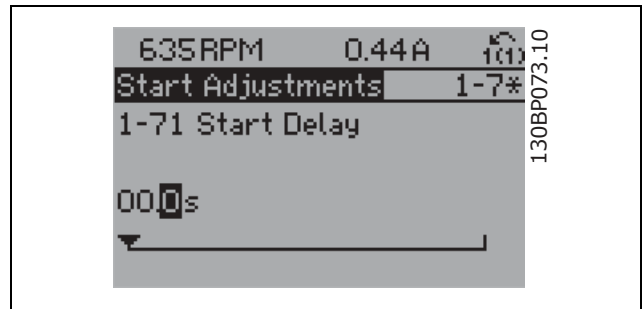

Change the selected digit infinitely variably by means of the up/down navigation keys. The chosen digit is indicated by the cursor. Place the cursor on the digit you want to save and press [OK].



## — How to Programme —

**□ Changing of Data Value, Step-by-Step**

Certain parameters can be changed step by step or infinitely variably. This applies to *Motor Power* (par. 1-20), *Motor Voltage* (par. 1-22) and *Motor Frequency* (par. 1-23).

The parameters are changed both as a group of numeric data values and as numeric data values infinitely variably.

**□ Read-out and Programming of Indexed Parameters**

Parameters are indexed when placed in a rolling stack.

Par. 15-30 to 15-32 contain a fault log which can be read out. Choose a parameter, press [OK], and use the up/down navigation keys to scroll through the value log.

Use par. 3-10 as another example:

Choose the parameter, press [OK], and use the up/down navigation keys to scroll through the indexed values. To change the parameter value, select the indexed value and press [OK].

Change the value by using the up/down keys. Press [OK] to accept the new setting. Press [CANCEL] to abort. Press [Back] to leave the parameter.

— How to Programme —

□ **How to Programme on the Numerical Local Control Panel**

The following instructions are valid for the Numerical LCP (LCP 101).

The control panel is divided into four functional groups:

1. Numerical display.
2. Menu keys and indicator lights - changing parameters and switching between display functions.
3. Navigation keys and indicator lights (LEDs).
4. Operation keys and indicator lights (LEDs).

**Display line:**

**Status line: Status messages displaying icons and numeric value.**

**Indicator lights (LEDs):**

- Green LED/On: Indicates if control section is on.
- Yellow LED/Wrn.: Indicates a warning.
- Flashing red LED/Alarm: Indicates an alarm.

**LCP keys**

[Menu] Select one of the following modes:

- Status
- Quick Setup
- Main Menu

**Status Mode:** Displays the status of the frequency converter or the motor.

If an alarm occurs the NLCP automatically switches to status mode.

A number of alarms can be displayed.



**NB!:**  
Parameter copy is not possible with LCP 101 Numerical Local Control Panel.

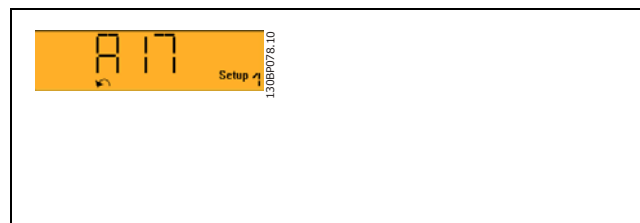
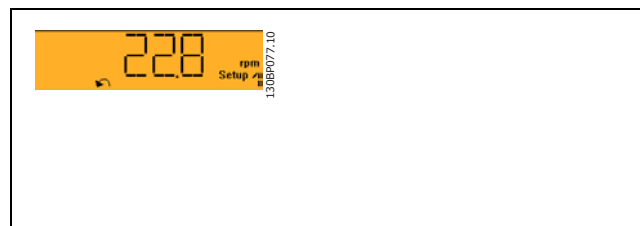
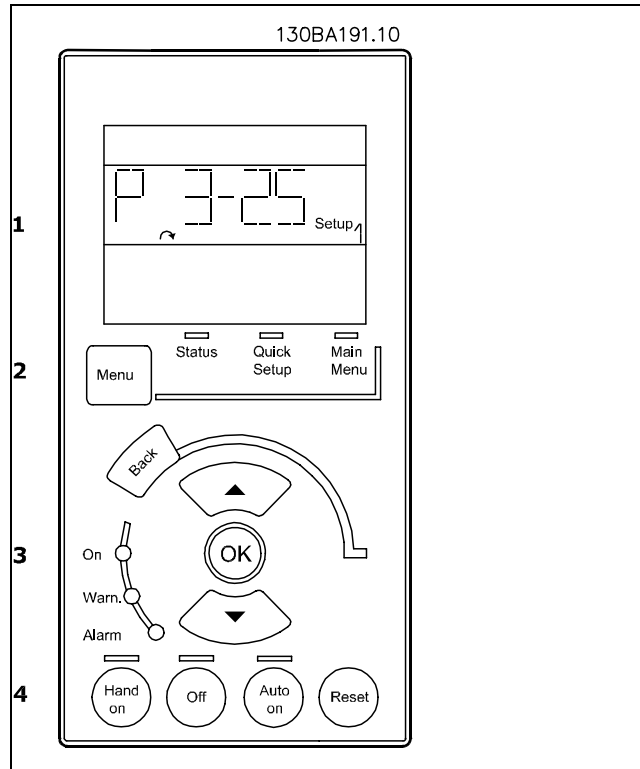



— How to Programme —

Par. No.	Parameter Description	Unit
1-20	Motor Power	kW
1-22	Motor Voltage	V
1-23	Motor Frequency	Hz
1-24	Motor Current	A
5-12	Terminal 27 Digital Input	[0] No function
3-02	Minimum Reference	rpm
3-03	Maximum Reference	rpm
3-41	Ramp 1 Ramp Up Time	sec
3-42	Ramp 1 Ramp Down Time	sec
3-13	Reference Site	
1-29	Automatic Motor Adaptation, AMA	[1] Enable complete AMA

**Main Menu** is used for programming all parameters. The parameter values can be changed using the up/down arrows when the value is flashing. Select Main Menu by pressing [Menu] key a number of times.

Select the parameter group [xx-\_\_] and press [OK]  
 Select the parameter [\_\_-xx] and press [OK]  
 If the parameter is an array parameter select the array number and press [OK]  
 Select the wanted data value and press [OK]

**[Back]** for stepping backwards

**Arrow** [^] [v] keys are used for manoeuvring between commands and within parameters.

□ **Local Control Keys**

Keys for local control are found at the bottom of the control panel.

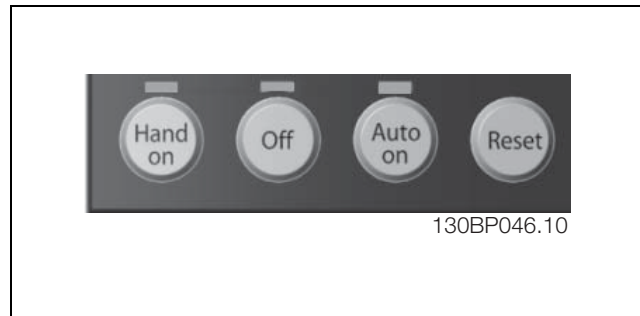

**[Hand on]** enables control of the frequency converter via the LCP. [Hand on] also starts the motor and it is now possible to enter the motor speed data by means of the arrow keys. The key can be selected as Enable [1] og Disable [0] via par. 0-40 [Hand on] Key on LCP.

## — How to Programme —

External stop signals activated by means of control signals or a serial bus will override a 'start' command via the LCP.

The following control signals will still be active when [Hand on] is activated:

- [Hand on] - [Off] - [Auto on]
- Reset
- Coasting stop inverse
- Reversing
- Set-up select lsb - Set-up select msb
- Stop command from serial communication
- Quick stop
- DC brake

**[Off]** stops the connected motor. The key can be selected as Enable [1] or Disable [0] via par. 0-41 *[Off] Key on LCP*.

If no external stop function is selected and the [Off] key is inactive the motor can be stopped by disconnecting the voltage.

**[Auto on]** enables the frequency converter to be controlled via the control terminals and/or serial communication. When a start signal is applied on the control terminals and/or the bus, the frequency converter will start. The key can be selected as Enable [1] or Disable [0] via par. 0-42 *[Auto on] Key on LCP*.

**NB!:**

An active HAND-OFF-AUTO signal via the digital inputs has higher priority than the control keys [Hand on] [Auto on].

**[Reset]** is used for resetting the frequency converter after an alarm (trip). It can be selected as Enable [1] or Disable [0] via par. 0-43 *Reset Keys on LCP*.

— How to Programme —

□ **Initialisation to Default Settings**

Initialise the frequency converter to default settings in two ways:

Recommended initialisation (via par. 14-22)

1. Select par. 14-22
2. Press [OK]
3. Select "Initialisation"
4. Press [OK]
5. Cut off the mains supply and wait until the display turns off.
6. Reconnect the mains supply - the frequency converter is now reset.

<b>Par. 14-22 initialises all except:</b>	
14-50	<i>RFI 1</i>
8-30	<i>Protocol</i>
8-31	<i>Address</i>
8-32	<i>Baud Rate</i>
8-35	<i>Minimum Response Delay</i>
8-36	<i>Max Response Delay</i>
8-37	<i>Max Inter-char Delay</i>
15-00 to 15-05	<i>Operating data</i>
15-20 to 15-22	<i>Historic log</i>
15-30 to 15-32	<i>Fault log</i>

Manual initialisation

1. Disconnect from mains and wait until the display turns off.
- 2a. Press [Status] - [Main Menu] - [OK] at the same time while power up for LCP 102, Graphical Display
- 2b. Press [Menu] while power up for LCP 101, Numerical Display
3. Release the keys after 5 s.
4. The frequency converter is now programmed according to default settings.

<b>This parameter initialises all except:</b>	
15-00	<i>Operating Hours</i>
15-03	<i>Power-up's</i>
15-04	<i>Over temp's</i>
15-05	<i>Over volt's</i>



**NB!:**

When you carry out manual initialisation, you also reset serial communication, RFI filter settings (par. 14-50) and fault log settings.

## □ Parameter Selection

Parameters for FC 300 are grouped into various parameter groups for easy selection the correct parameters for optimized operation of the frequency converter.

0-xx Operation and Display parameters

- Basic Settings, set-up handling
- Display and Local Control Panel parameters for choosing readouts, setting up selections and copying functions

1-xx Load and Motor parameters includes all load and motor related parameters

2-xx Brake parameters

- DC brake
- Dynamic brake (Resistor brake)
- Mechanical brake
- Over Voltage Control

3-xx References and ramping parameters includes DigiPot function

4-xx Limits Warnings; setting of limits and warning parameters

5-xx Digital inputs and outputs includes relay controls

6-xx Analog inputs and outputs

7-xx Controls; Setting parameters for speed and process controls

8-xx Communication and option parameters for setting of FC RS485 and FC USB port parameters.

9-xx Profibus parameters

10-xx DeviceNet and CAN Fieldbus parameters

13-xx Smart Logic Control parameters

14-xx Special function parameters

15-xx Drive information parameters

16-xx Read out parameters

17-xx Encoder Option parameters

□ **Parameters: Operation and Display**

□ **0-0\* Operation / Display**

Parameters related to the fundamental functions of the frequency converter, function of the LCP buttons and configuration of the LCP display.

□ **0-0\* Basic Settings**

Parameter group for basic frequency converter settings.

**0-01 Language**

**Option:**

*English (ENGLISH)	[0]
German (DEUTSCH)	[1]
French (FRANCAIS)	[2]
Danish (DANSK)	[3]
Spanish (ESPAÑOL)	[4]
Italian (ITALIANO)	[5]
Chinese (CHINESE)	[10]
Finnish (FINNISH)	[20]
English US (ENGLISH US)	[22]
Greek (GREEK)	[27]
Portuguese (PORTUGUESE)	[28]
Slovenian (SLOVENIAN)	[36]
Korean (KOREAN)	[39]
Japanese (JAPANESE)	[40]
Turkish (TURKISH)	[41]
Traditional Chinese	[42]
Bulgarian	[43]
Serbian	[44]
Romanian (ROMANIAN)	[45]
Hungarian (HUNGARIAN)	[46]
Czech	[47]
Polish (POLISH)	[48]
Russian	[49]
Thai	[50]
Bahasa Indonesian (BAHASA INDONESIA)	[51]

**Function:**

Defines the language to be used in display.

The frequency converter can be delivered with 4 various language packages. English and German are included in all packages. English cannot be erased or manipulated.

Language package 1 consists of: English, German, French, Danish, Spanish, Italian and Finnish.

Language package 2 consists of:

English, German, Chinese, Korean, Japanese, Thai and Bahasa Indonesian.

Language package 3 consists of: English, German, Slovenian, Bulgarian, Serbian, Romanian, Hungarian, Czech and Russian.

Language package 4 consists of: English, German, Spanish, English US, Greek, Brazilian Portuguese, Turkish and Polish.

**0-02 Motor Speed Unit**

**Option:**

*RPM	[0]
Hz	[1]

**Function:**

Select display of motor speed parameters (i.e. references, feedbacks and limits) in terms of shaft speed (RPM) or output frequency to the motor (Hz). This parameter cannot be adjusted while the motor is running.

**0-03 Regional Settings**

**Option:**

*International	[0]
US	[1]

**Function:**

Select *International* [0] to set par.1-20 *Motor Power* units to kW and the default value of par. 1-23*Motor Frequency* to 50 Hz. Select *US* [1] to set par.1-21 *Motor Power* units to HP and the default value of par. 1-23 *Motor Frequency* to 60 Hz. This parameter cannot be adjusted while the motor is running.

**0-04 Operating State at Power-up (Hand)**

**Option:**

Resume	[0]
*Forced stop, ref=old	[1]
Forced stop, ref = 0	[2]

**Function:**

Select the operating mode upon reconnection of the frequency converter to mains voltage after power down in Hand (local) operation mode. Select *Resume* [0] to restart the frequency converter maintaining the same local reference and the same start/stop settings (applied by [START/STOP]) as before the frequency converter was powered down. Select *Forced stop, use saved reference* [1] to restart the frequency converter with a saved

\* default setting ( ) display text [ ] value for use in communication via serial communication port

— How to Programme —

local reference, after mains voltage reappears and after pressing [START].

Select *Forced stop, set reference to 0* [2] to reset the local reference to 0 upon restarting the frequency converter.

□ **0-1\* Set-up Operations**

Define and control the individual parameter set-ups.

**0-10 Active Set-up**

**Option:**

Factory setup	[0]
*Set-up 1	[1]
Set-up 2	[2]
Set-up 3	[3]
Set-up 4	[4]
Multi set-up	[9]

**Function:**

Select the set-up to control the frequency converter functions. *Factory Set-up* [0] cannot be changed. It contains the Danfoss data set, and can be used as a data source when returning the other set-ups to a known state. *Set-up 1* [1] to *Set-up 4* [4] are the four separate parameter set-ups within which all parameters can be programmed. Select *Multi Set-up* [9] for remote selection of set-ups using digital inputs and the serial communication port. This option uses the settings from par. 0-12 This option linked to. Stop the frequency converter before making changes to open loop and closed loop functions. Use par. 0-51 *Set-up copy* to copy a set-up to one or all other set-ups. Stop the frequency converter before switching between set-ups where parameters marked 'not changeable during operation' have different values. To avoid conflicting settings of the same parameter within two different set-ups, link the set-ups together using par. 0-12 *This set-up linked to*. Parameters which are 'not changeable during operation' are marked FALSE in the parameter lists in the section *Parameter Lists*.

**0-11 Edit Set-up**

**Option:**

Factory setup	[0]
*Set-up 1	[1]
Set-up 2	[2]
Set-up 3	[3]
Set-up 4	[4]
Active Set-up	[9]

**Function:**

Select the set-up to be edited (i.e. programmed) during operation; either the active set-up or one of the inactive set-ups.

*Factory set-up* [0] cannot be edited but it is useful as a data source to return the other set-ups to a known state. *Set-up 1* [1] to *Set-up 4* [4] can be edited freely during operation, independently of the active set-up. The *Active set-up* [9] can also be edited during operation. Edit the chosen set-up from a range of sources: LCP, FC RS485, FC USB or up to five fieldbus sites.

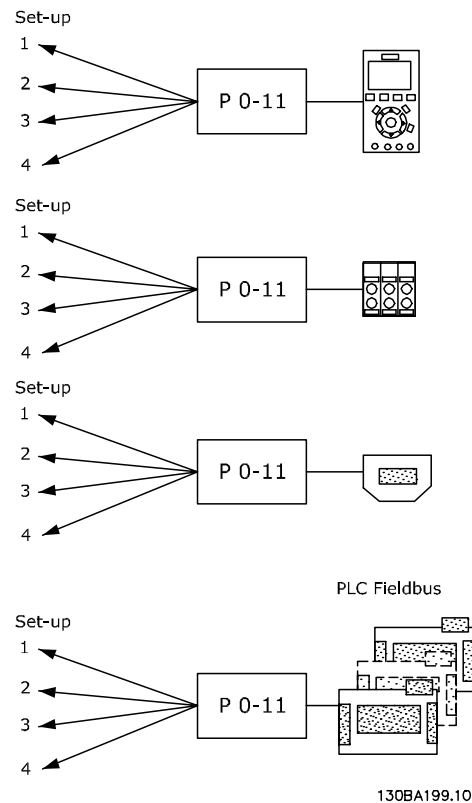

**0-12 This Set-up Linked to**

**Option:**

*Set-up 1	[1]
Set-up 2	[2]
Set-up 3	[3]
Set-up 4	[4]

**Function:**

To enable conflict-free changes from one set-up to another during operation, link set-ups containing parameters which are not changeable during operation. The link will ensure synchronising of the 'not changeable during operation' parameter values when moving from one set-up to another during operation. 'Not changeable during operation'

\* default setting ( ) display text [ ] value for use in communication via serial communication port

— How to Programme —

parameters can be identified by the label FALSE in the parameter lists in the section *Parameter Lists*.

The par. 0-12 link set-up feature is used by Multi set-up in par. 0-10 *Active Set-up*. Multi set-up is used to move from one set-up to another during operation (i.e. while the motor is running).

Example:

Use Multi set-up to shift from Set-up 1 to Set-up 2 whilst the motor is running. Programme in Set-up 1 first, then ensure that Set-up 1 and Set-up 2 are synchronised (or 'linked'). Synchronisation can be performed in two ways:

1. Change the edit set-up to *Set-up 2* [2] in par.0-11 *Edit Set-up* and set par. 0-12 *This Set-up Linked to* to *Set-up 1* [1]. This will start the linking (synchronising) process.

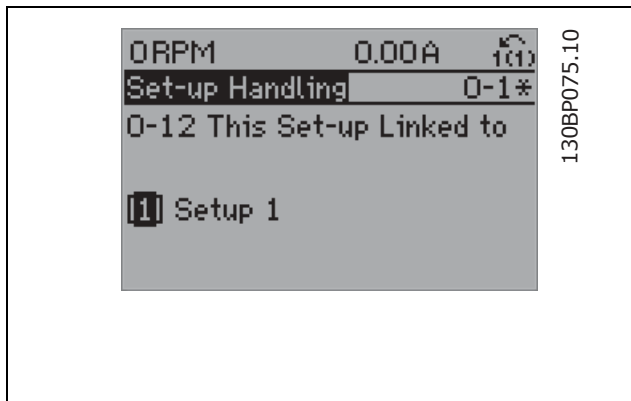

OR

2. While still in Set-up 1, copy Set-up 1 to Set-up 2. Then set par.0-12 to *Set-up 2* [2]. This will start the linking process.

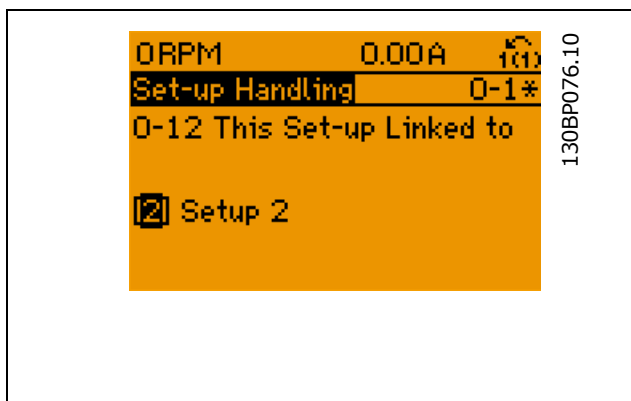

After the link is complete, par. 0-13 *Readout: Linked Set-ups* will read {1,2} to indicate that all

'not changeable during operation' parameters on are now the same in Set-up 1 and Set-up 2. If there are changes to a 'not changeable during operation' parameter, e.g. par 1-30 *Stator Resistance (rs)*, in Set-up 2, they will also be changed automatically in Set-up 1. A switch between Set-up 1 and Set-up 2 during operation is now possible.

**0-13 Readout: Linked Set-ups**

Array [5]

**Range:**

0 - 255 N/A \*0 N/A

**Function:**

View a list of all the set-ups linked by means of par. 0-12 *This Set-up Linked to*. The parameter has one index for each parameter set-up. Each set-up shows the set-up bitset to which it is linked.

**Example: Set-up 1 and Set-up 2 are linked**

Index	LCP value
0	{0}
1	{1,2}
2	{1,2}
3	{3}
4	{4}

**0-14 Readout: Edit Set-ups / Channel**

**Range:**

0 - FFF.FFF.FFF \*AAA.AAA.AAA

**Function:**

View the setting of par. 0-11 *Edit Set-up* for each of the four different communication channels. When the number is displayed in hex, as it is in the LCP, each number represents one channel.

Numbers 1-4 represent a set-up number; 'F' means factory setting; and 'A' means active set-up. The channels are, from right to left: LCP, FC-bus, USB, HPFB1.5.

Example: The number AAAAAA21h means that the FC bus selected Set-up 2 in par. 0-11, the LCP selected Set-up 1 and all others used the active set-up.

□ **0-2\* LCP Display**

Define the display in the Graphical Logic Control Panel.

\* default setting ( ) display text [ ] value for use in communication via serial communication port

## — How to Programme —

**0-20 Display Line 1.1 Small**

None	[0]	Warning Word 2	[1693]
Profibus Warning Word	[953]	Ext. Status Word	[1694]
Readout Transmit Error Counter	[1005]	Ext. Status Word 2	[1695]
Readout Receive Error Counter	[1006]	PCD 1 Write to MCO	[3401]
Readout Bus Off Counter	[1007]	PCD 2 Write to MCO	[3402]
Warning Parameter	[1013]	PCD 3 Write to MCO	[3403]
Running Hours	[1501]	PCD 4 Write to MCO	[3404]
kWh Counter	[1502]	PCD 5 Write to MCO	[3405]
Control Word	[1600]	PCD 6 Write to MCO	[3406]
Reference [Unit]	[1601]	PCD 7 Write to MCO	[3407]
Reference %	[1602]	PCD 8 Write to MCO	[3408]
Status Word	[1603]	PCD 9 Write to MCO	[3409]
Main Actual Value [%]	[1605]	PCD 10 Write to MCO	[3410]
Custom Readout	[1609]	PCD 1 Read from MCO	[3421]
Power [kW]	[1610]	PCD 2 Read from MCO	[3422]
Power [hp]	[1611]	PCD 3 Read from MCO	[3423]
Motor Voltage	[1612]	PCD 4 Read from MCO	[3424]
Frequency	[1613]	PCD 5 Read from MCO	[3425]
Motor Current	[1614]	PCD 6 Read from MCO	[3426]
Frequency [%]	[1615]	PCD 7 Read from MCO	[3427]
Torque	[1616]	PCD 8 Read from MCO	[3428]
* Speed [RPM]	[1617]	PCD 9 Read from MCO	[3429]
Motor Thermal	[1618]	PCD 10 Read from MCO	[3430]
KTY Sensor Temperature	[1619]	Digital Inputs	[3440]
Motor Angle	[1620]	Digital Outputs	[3441]
Phase Angle	[1621]	Actual Position	[3450]
DC Link Voltage	[1630]	Commanded Position	[3451]
BrakeEnergy/s	[1632]	Actual Master Position	[3452]
BrakeEnergy/2 min	[1633]	Slave Index Position	[3453]
Heatsink Temp.	[1634]	Master Index Position	[3454]
Inverter Thermal	[1635]	Curve Position	[3455]
Inv. Nom. Current	[1636]	Track Error	[3456]
Inv. Max. Current	[1637]	Synchronizing Error	[3457]
SL Control State	[1638]	Actual Velocity	[3458]
Control Card Temp.	[1639]	Actual Master Velocity	[3459]
External Reference	[1650]	Synchronizing Status	[3460]
Pulse Reference	[1651]	Axis Status	[3461]
Feedback [Unit]	[1652]	Program Status	[3462]
Digi Pot Reference	[1653]	Idle Time	[9913]
Digital Input	[1660]	Paramdb Requests in Queue	[9914]
Terminal 53 Switch Setting	[1661]	Analog input X30/11	[1675]
Analog Input 53	[1662]	Analog input X30/12	[1676]
Terminal 54 Switch Setting	[1663]	Analog output X30/8 mA	[1677]
Analog Input 54	[1664]		
Analog Output 42 [mA]	[1665]		
Digital Output [bin]	[1666]		
Freq. Input #29 [Hz]	[1667]		
Freq. Input #33 [Hz]	[1668]		
Pulse Output #27 [Hz]	[1669]		
Pulse Output #29 [Hz]	[1670]		
Relay Output [bin]	[1671]		
Counter A	[1672]		
Counter B	[1673]		
Fieldbus CTW 1	[1680]		
Fieldbus REF 1	[1682]		
Comm. Option STW	[1684]		
FC Port CTW 1	[1685]		
FC Port REF 1	[1686]		
Alarm Word	[1690]		
Alarm Word 2	[1691]		
Warning Word	[1692]		

**Function:**

Select a variable for display in line 1, left position.

*None* [0] No display value selected

*Control Word* [1600] Present control word

*Reference [Unit]* [1601] Total reference (sum of digital/analog/preset/bus/freeze ref./catch up and slow-down) in selected unit.

*Reference %* [1602] Total reference (sum of digital/analog/preset/bus/freeze ref./catch up and slow-down) in percent.

*Status Word [binary]* [1603] Present status word

*Main actual value* [1605] [Hex] One or more warnings in a Hex code

*Power [kW]* [1610] Actual power consumed by the motor in kW.

\* default setting ( ) display text [ ] value for use in communication via serial communication port



— How to Programme —

*Power [hp]* [1611] Actual power consumed by the motor in HP.  
*Motor Voltage [V]* [1612] Voltage supplied to the motor.  
*Frequency [Hz]* [1613] Motor frequency, i.e. the output frequency from the frequency converter in Hz.  
*Motor Current [A]* [1614] Phase current of the motor measured as effective value.  
*Frequency [%]* [1615] Motor frequency, i.e. the output frequency from the frequency converter in percent.  
*Torque [%]* [1616] Present motor load as a percentage of the rated motor torque.  
*\*Speed [RPM]* [1617] Speed in RPM (revolutions per minute) i.e. the motor shaft speed in closed loop.  
*Motor thermal* [1618] Thermal load on the motor, calculated by the ETR function.  
*DC Link Voltage [V]* [1630] Intermediate circuit voltage in the frequency converter.  
*BrakeEnergy/s* [1632] Present brake power transferred to an external brake resistor. Stated as an instantaneous value.  
*BrakeEnergy/2 min* [1633] Brake power transferred to an external brake resistor. The mean power is calculated continuously for the most recent 120 seconds.  
*Heatsink Temperature [oC]* [1634] Present heat sink temperature of the frequency converter. The cut-out limit is 95 ±5 oC; cutting back in occurs at 70 ±5° C.  
*Inverter thermal* [1635] Percentage load of the inverters  
*Inv. Nom. Current* [1636] Nominal current of the frequency converter  
*Inv. Max. Current* [1637] Maximum current of the frequency converter  
*Condition control state* [1638] State of the event executed by the control  
*Control Card Temperature* [1639] Temperature of the control card.  
*External Reference* [1650] [%] Sum of the external reference as a percentage, i.e. the sum of analog/pulse/bus.  
*Pulse Reference* [1651] [Hz] Frequency in Hz connected to the digital inputs (18, 19 or 32, 33).  
*Feedback [Unit]* [1652] Reference value from programmed digital input(s).  
*Digital Input* [1660] Signal states form the 6 digital terminals (18, 19, 27, 29, 32 and 33). Input 18 corresponds to the bit at the far left. Signal low = 0; Signal high = 1  
*Terminal 53 Switch Setting* [1661] Setting of input terminal 54. Current = 0; Voltage = 1.  
*Analog Input 53* [1662] Actual value at input 53 either as a reference or protection value.

*Terminal 54 Switch Setting* [1663] Setting of input terminal 54. Current = 0; Voltage = 1.  
*Analog Input 54* [1664] Actual value at input 54 either as reference or protection value.  
*Analog Output 42 [mA]* [1665] Actual value at output 42 in mA. Use par. 6-50 to select the value to be shown.  
*Digital output [bin]* [1666] Binary value of all digital outputs.  
*Frequency input #29 [Hz]* [1667] Actual value of the frequency applied at terminal 29 as an impulse input.  
*Frequency input #33 [Hz]* [1668] Actual value of the frequency applied at terminal 33 as an impulse input.  
*Pulse output #27 [Hz]* [1669] Actual value of impulses applied to terminal 27 in digital output mode.  
*Pulse output #29 [Hz]* [1670] Actual value of impulses applied to terminal 29 in digital output mode.  
*Fieldbus control word1 signal* [1680] Control word (CTW) received from the Bus Master.  
*Fieldbus speed set-point A signal* [1682] Main reference value sent with control word from the Bus Master.  
*Communication Option Status Word [binary]* [1684] Extended fieldbus communication option status word.  
*FC port control word1 signal* [1685] Control word (CTW) received from the Bus Master.  
*FC port speed set-point A signal* [1686] Status word (STW) sent to the Bus Master.  
*Alarm word [Hex]* [1690] One or more alarms in a Hex code  
*Alarm word 2 [Hex]* [1691] One or more alarms in a Hex code  
*Warning word [Hex]* [1692] One or more warnings in a Hex code  
*Warning word 2 [Hex]* [1693] One or more warnings in a Hex code  
*Ext. status word [Hex]* [1694] One or more status conditions in a Hex code  
*Ext. status word 2 [Hex]* [1695] One or more status conditions in a Hex code

**0-21 Display Line 1.2 Small**

**Option:**

\*Motor Current [A] [1614]

Options are the same as in par. 0-20.

**Function:**

Select a variable for display in line 1, middle position. The options are the same as those listed for par. 0-20 *Display Line 1.1 Small*.

\* default setting ( ) display text [ ] value for use in communication via serial communication port

— How to Programme —

**0-22 Display Line 1.3 Small**

**Option:**

\*Power [kW] [1610]

Options are the same as in par. 0-20.

**Function:**

Select a variable for display in line 1, right position. The options are the same as those listed for par. 0-20 *Display Line 1.1 Small*.

**0-23 Display Line 2 Large**

**Option:**

\*Frequency [Hz] [1613]

Options are the same as in par. 0-20.

**Function:**

Select a variable for display in line 2. The options are the same as those listed for par. 0-20 *Display Line 1.1 Small*.

**0-24 Display Line 3 Large**

**Option:**

\*Reference [%] [1602]

Options are the same as in par. 0-20.

**Function:**

Select a variable for display in line 3. The options are the same as those listed for par. 0-20 *Display Line 1.1 Small*.

**0-25 My Personal Menu**

Array [20]

**Range:**

0 - 9999

**Function:**

Define up to 20 parameters to include in the Q1 Personal Menu, accessible via the [Quick Menu] key on the LCP. The parameters will be displayed in the Q1 Personal Menu in the order they are programmed into this array parameter. Delete parameters by setting the value to '0000'.

□ **0-4\* LCP Keypad**

Enable and disable individual keys on the LCP keypad.

**0-40 [Hand on] Key on LCP**

**Option:**

Disabled [0]

\*Enabled [1]

Password [2]

**Function:**

Select *Disabled* [0] to avoid accidental start of the frequency converter in Hand mode. Select *Password* [2] to avoid unauthorised start in Hand mode. If par. 0-40 is included in the Quick Menu, then define the password in par. 0-65 *Quick Menu Password*.

**0-41 [Off] Key on LCP**

**Option:**

Disabled [0]

\*Enabled [1]

Password [2]

**Function:**

Press [Off] and select *Disabled* [0] to avoid accidental stop of the frequency converter. Press [Off] and select *Password* [2] to avoid unauthorised stop. If par. 0-41 is included in the Quick Menu, then define the password in par. 0-65 *Quick Menu Password*.

**0-42 [Auto on] Key on LCP**

**Option:**

Disabled [0]

\*Enabled [1]

Password [2]

**Function:**

Press [Auto on] and select *Disabled* [0] to avoid accidental start of the frequency converter in Auto mode. Press [Auto on] and select *Password* [2] to avoid unauthorised start in Auto mode. If par. 0-42 is included in the Quick Menu, then define the password in par. 0-65 *Quick Menu Password*.

**0-43 [Reset] Key on LCP**

**Option:**

Disabled [0]

\*Enabled [1]

Password [2]

**Function:**

Press [Reset] and select *Disabled* [0] to avoid accidental alarm reset. Press [Reset] and select *Password* [2] to avoid unauthorised resetting. If par. 0-43 is included in the Quick Menu, then define the password in par. 0-65 *Quick Menu Password*.

\* default setting ( ) display text [ ] value for use in communication via serial communication port

— How to Programme —

□ **0-5\* Copy / Save**

Copy parameter settings between set-ups and to/from the LCP.

**0-50 LCP Copy**

**Option:**

*No copy	[0]
All to LCP	[1]
All from LCP	[2]
Size indep. from LCP	[3]
File from MCO to LCP	[4]
File from LCP to MCO	[5]

**Function:**

Select *Transfer to LCP all parameters* [1] to copy all parameters in all set-ups from the frequency converter memory to the LCP memory. Select *Transfer from LCP all parameters* [2] to copy all parameters in all set-ups from the LCP memory to the frequency converter memory. Select *Transfer from LCP size indep. parameters* [3] to copy only the parameters that are independent of the motor size. The latter selection can be used to programme several drives with the same function without disturbing motor data which are already set. This parameter cannot be adjusted while the motor is running.

**0-51 Set-up Copy**

**Option:**

*No copy	[0]
Copy to set-up 1	[1]
Copy to set-up 2	[2]
Copy to set-up 3	[3]
Copy to set-up 4	[4]
Copy to all	[9]

**Function:**

Select *Copy to set-up 1* [1] to copy all parameters in the present edit set-up (defined in par. 0-11 *Edit Set-up*) to Set-up 1. Likewise, select the option corresponding to the other set-up(s). Select *Copy to all* [9] to copy the parameters in the present set-up over to each of the set-ups 1 to 4.

□ **0-6\* Password**

Define password access to menus.

**0-60 Main Menu Password**

**Range:**

0 - 999 \*100

**Function:**

Define the password for access to the Main Menu via the [Main Menu] key. If par. 0-61 *Access to*

\* default setting ( ) display text [ ] value for use in communication via serial communication port

*Main Menu w/o Password* is set to *Full access* [0], this parameter will be ignored.

**0-61 Access to Main Menu w/o Password**

**Option:**

*Full access	[0]
Read only	[1]
No access	[2]

**Function:**

Select *Full access* [0] to disable the password defined in par. 0-60 *Main Menu Password*. Select *Read only* [1] to prevent unauthorised editing of Main Menu parameters. Select *No access* [2] to prevent unauthorised viewing and editing of Main Menu parameters. If *Full access* [0] is selected then parameters 0-60, 0-65 and 0-66 will be ignored.

**0-65 Quick Menu Password**

**Range:**

0 - 999 \*200

**Function:**

Define the password for access to the Quick Menu via the [Quick Menu] key. If par. 0-66 *Access to Quick Menu w/o Password* is set to *Full access* [0], this parameter will be ignored.

**0-66 Access to Quick Menu w/o Password**

**Option:**

*Full access	[0]
Read only	[1]
No access	[2]

**Function:**

Select *Full access* [0] to disable the password defined in par. 0-65 *Quick Menu Password*. Select *Read only* [1] to prevent unauthorised editing of Quick Menu parameters. Select *No access* [2] to prevent unauthorised viewing and editing of Quick Menu parameters. If par. 0-61 *Access to Main Menu w/o Password* is set to *Full access* [0] then this parameter will be ignored.

□ **Parameters: Load and Motor**

□ **1-0\* General Settings**

Define whether the frequency converter operates in speed mode or torque mode; and whether the internal PID control should be active or not.

**1-00 Configuration Mode**

**Option:**

*Speed open loop	[0]
Speed closed loop	[1]
Torque	[2]
Process	[3]

**Function:**

Select the application control principle to be used when a Remote Reference (via analog input) is active. A Remote Reference can only be active when par. 3-13 *Reference Site* is set to [0] or [1].  
*Speed open loop* [0]: Enables speed control (without feedback signal from motor) with automatic slip compensation for almost constant speed at varying loads. Compensations are active but can be disabled in the Load/Motor par. group 1-0\*.  
*Speed closed loop* [1]: Enables encoder feedback from motor. Obtain full holding torque at 0 RPM. For increased speed accuracy, provide a feedback signal and set the speed PID control.  
*Torque* [2]: Connects the encoder speed feedback signal to the encoder input. Only possible with "Flux with motor feedback" option, par. 1-01 *Motor control principle*.  
*Process* [3]: Enables the use of process control in the frequency converter. The process control parameters are set in par. groups 7-2\* and 7-3\*. This parameter cannot be adjusted while the motor is running.

**1-01 Motor Control Principle**

**Option:**

U/f	[0]
*VVC <sup>plus</sup>	[1]
Flux sensorless (FC 302 only)	[2]
Flux w/ motor feedback(FC302only)	[3]

**Function:**

Select which motor control principle to employ. Select *U/f* [0], a special motor mode, for parallel connected motors in special motor applications. When U/f is selected the characteristic of the control principle can be edited in par. 1-55 and 1-56. Select *VVC<sup>plus</sup>* [1] for a Voltage Vector Control principle suitable for most applications. The

\* default setting ( ) display text [ ] value for use in communication via serial communication port

main benefit of VVC<sup>plus</sup> operation is that it uses a robust motor model.

Select *Flux sensorless* [2], i.e. Flux Vector control without encoder feedback, for simple installation and robustness against sudden load changes. Select *Flux with encoder feedback* [3] for very high accuracy speed and torque control, suitable for the most demanding applications.

The best shaft performance is normally achieved using either of the two Flux Vector control modes *Flux sensorless* [2] and *Flux with encoder feedback* [3]. This parameter cannot be adjusted while the motor is running.

**1-02 Flux Motor Feedback Source**

**Option:**

*24 V encoder	[1]
MCB 102	[2]
MCO 305	[3]

**Function:**

Select the interface at which to receive feedback from motor or process.  
*24V encoder* [1] is an A and B channel encoder, which can be connected to the digital input terminals 32/33 only. Terminals 32/33 must be programmed to *no function*.  
*MCB 102* [2] is an encoder module option which can be configured in par. group 17-\*\* *Parameters - Encoder Input*.  
*MCO 305* [3] is an option for positioning, synchronizing and programming. This parameter cannot be adjusted while the motor is running. This parameter appears in FC 302 only.

**1-03 Torque Characteristics**

**Option:**

*Constant torque	[0]
Variable torque	[1]
Auto energy optim.	[2]

**Function:**

Select the torque characteristic required. VT and AEO are both energy saving operations.  
*Constant torque* [0]: The motor shaft output will provide constant torque under variable speed control.  
*Variable Torque* [1]: The motor shaft output will provide variable torque under variable speed control. Set the variable torque level in par. 14-40 *VT Level*.  
*Automatic Energy Optimizing function* [2]: This function automatically optimises energy consumption by minimising magnetisation

— How to Programme —

and frequency via par. 14-41 *AEO Minimum Magnetisation* and par. 14-42 *Minimum AEO Frequency*.

**1-04 Overload Mode**

**Option:**

- \*High torque [0]
- Normal torque [1]

**Function:**

*High torque* [0] allows up to 160% over torque. *Normal torque* [1] is for oversized motor - allows up to 110% over torque. This parameter cannot be adjusted while the motor is running.

**1-05 Local Mode Configuration**

**Option:**

- Speed open loop [0]
- Speed closed loop [1]
- \*As conf. mode par. 1-00 [2]

**Function:**

Select which application configuration mode (par. 1-00), i.e. application control principle, to use when a Local (LCP) Reference is active. A Local Reference can be active only when par. 3-13 *Reference Site* is set to [0] or [2]. By default the local reference is active in Hand Mode only.

□ **1-1\* Motor selection**

Parameter group for setting general motor data. This parameter group cannot be adjusted while the motor is running.

**1-10 Motor Construction**

**Option:**

- \*Asynchronous [0]
- PM, non salient SPM (FC 302 only) [1]

**Function:**

Select the motor design type. Select *Asynchronous* [0] for asynchronous motors. Select *PM, non salient SPM (FC 302 only)* [1] for permanent magnet (PM) motors. Note that PM motors are divided into two groups, with either surface mounted (non salient) or interior (salient) magnets.

Motor design can either be asynchronous or permanent magnet (PM) motor.

□ **1-2\* Motor Data**

Parameter group 1-2\* comprises input data from the nameplate on the connected motor.

Parameters in parameter group 1-2\* cannot be adjusted while the motor is running.



**NB!:**

Changing the value of these parameters affects the setting of other parameters.

**1-20 Motor Power [kW]**

**Range:**

0.37-7.5 kW [M-TYPE]

**Function:**

Enter the nominal motor power in kW according to the motor nameplate data. The default value corresponds to the nominal rated output of the unit. This parameter cannot be adjusted while the motor is running.

**1-21 Motor Power [HP]**

**Range:**

0.5-10 HP [M-TYPE]

**Function:**

Enter the nominal motor power in HP according to the motor nameplate data. The default value corresponds to the nominal rated output of the unit. This parameter cannot be adjusted while the motor is running.

**1-22 Motor Voltage**

**Range:**

200-600 V [M-TYPE]

**Function:**

Enter the nominal motor voltage according to the motor nameplate data. The default value corresponds to the nominal rated output of the unit. This parameter cannot be adjusted while the motor is running.

**1-23 Motor Frequency**

**Option:**

- \*50 Hz (50 HZ) [50]
- 60 Hz (60 HZ) [60]
- Min - Max motor frequency: 20 - 300 Hz

**Function:**

Select the motor frequency value from the motor nameplate data. Alternatively, set the value for motor frequency to be infinitely variable. If a value different from 50 Hz or 60 Hz is selected, it is necessary to adapt the load independent settings in par. 1-50 to 1-53. For 87 Hz operation with 230/400 V motors, set the nameplate data for

\* default setting ( ) display text [ ] value for use in communication via serial communication port

— How to Programme —

230 V/50 Hz. Adapt par. 4-13 *Motor Speed High Limit [RPM]* and par. 3-03 *Maximum Reference* to the 87 Hz application. This parameter cannot be adjusted while the motor is running.

**1-24 Motor Current**

**Range:**

Motor type dependent.

**Function:**

Enter the nominal motor current value from the motor nameplate data. The data are used for calculating torque, motor protection etc. This parameter cannot be adjusted while the motor is running.

**1-25 Motor Nominal Speed**

**Range:**

100 - 60000 RPM \* RPM

**Function:**

Enter the nominal motor speed value from the motor nameplate data. The data are used for calculating motor compensations. This parameter cannot be adjusted while the motor is running.

**1-26 Motor Cont. Rated Torque**

**Range:**

1.0 - 10000.0 Nm \* 5.0Nm

**Function:**

Enter the value from the motor nameplate data. The default value corresponds to the nominal rated output. This parameter is available when par. 1-10 *Motor Design* is set to *PM, non salient SPM* [1], i.e. the parameter is valid for PM and non-salient SPM motors only.

This parameter cannot be adjusted while the motor is running.

**1-29 Automatic Motor Adaptation (AMA)**

**Option:**

- \* OFF [0]
- Enable complete AMA [1]
- Enable reduced AMA [2]

**Function:**

The AMA function optimises dynamic motor performance by automatically optimising the advanced motor parameters (par. 1-30 to par. 1-35) while the motor is stationary. Select the type of AMA. *Enable complete AMA* [1] performs AMA of the stator resistance  $R_s$ , the rotor resistance  $R_r$ , the stator leakage reactance

$x_1$ , the rotor leakage reactance  $X_2$  and the main reactance  $X_h$ . Select this option if an LC filter is used between the drive and the motor.

**FC 301:** The Complete AMA does not include  $X_h$  measurement for FC 301. Instead, the  $X_h$  value is determined from the motor database. Par. 1-35 *Main Reactance ( $X^h$ )* may be adjusted to obtain optimal start performance.

Select *Reduced AMA* [2] performs a reduced AMA of the stator resistance  $R_s$  in the system only. Activate the AMA function by pressing [Hand on] after selecting [1] or [2]. See also the section *Automatic Motor Adaptation*. After a normal sequence, the display will read: "Press [OK] to finish AMA". After pressing the [OK] key the frequency converter is ready for operation. Note:

- For the best adaptation of the frequency converter, run AMA on a cold motor.
- AMA cannot be performed while the motor is running.
- AMA cannot be performed on permanent magnet motors.



**NB!:**

It is important to set motor par. 1-2\* Motor Data correctly, since these form part of the AMA algorithm. An AMA must be performed to achieve optimum dynamic motor performance. It may take up to 10 min, depending on the power rating of the motor.



**NB!:**

Avoid generating external torque during AMA.



**NB!:**

If one of the settings in par. 1-2\* Motor Data is changed, par. 1-30 to 1-39, the advanced motor parameters, will return to default setting. This parameter cannot be adjusted while the motor is running.

□ **1-3\* Adv. Motor Data**

Parameters for advanced motor data. The motor data in par. 1-30 - par. 1-39 must match the relevant motor in order to run the motor optimally. The default settings are figures based on common motor parameter values from normal standard motors. If the motor parameters are not set correctly, a malfunction of the drive system may occur. If the motor data is not known, running an AMA (Automatic Motor Adaptation) is recommended.

\* default setting ( ) display text [ ] value for use in communication via serial communication port

— How to Programme —

See the *Automatic Motor Adaptation* section. The AMA sequence will adjust all motor parameters except the moment of inertia of the rotor and the iron loss resistance (par. 1-36). Parameters 1-3\* and 1-4\* cannot be adjusted while the motor is running.

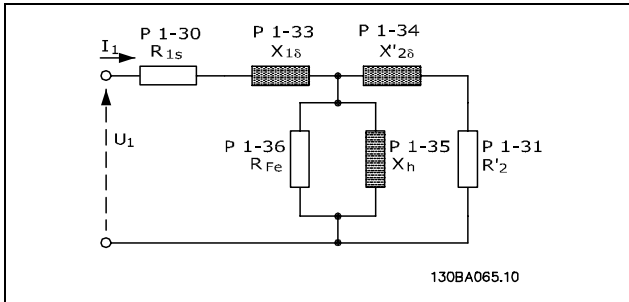

Motor equivalent diagram for an asynchronous motor

**1-30 Stator Resistance (Rs)**

**Option:**

Ohm Depending on motor data.

**Function:**

Set the stator resistance value. Enter the value from a motor data sheet or perform an AMA on a cold motor. This parameter cannot be adjusted while the motor is running.

**1-31 Rotor Resistance (Rr)**

**Option:**

Ohm Depending on motor data.

**Function:**

Fine-tuning  $R_r$  will improve shaft performance. Set the rotor resistance value using one of these methods:

1. Run an AMA on a cold motor. The frequency converter will measure the value from the motor. All compensations are reset to 100%.
2. Enter the  $R_r$  value manually. Obtain the value from the motor supplier.
3. Use the  $R_r$  default setting. The frequency converter establishes the setting on the basis of the motor nameplate data.

This parameter cannot be adjusted while the motor is running.

**1-33 Stator Leakage Reactance (X1)**

**Option:**

Ohm Depending on motor data.

**Function:**

Set the stator leakage reactance of the motor using one of these methods:

1. Run an AMA on a cold motor. The frequency converter will measure the value from the motor.
2. Enter the  $X_1$  value manually. Obtain the value from the motor supplier.
3. Use the  $X_1$  default setting. The frequency converter establishes the setting on the basis of the motor name plate data.

This parameter cannot be adjusted while the motor is running.

**1-34 Rotor Leakage Reactance (X2)**

**Option:**

Ohm Depending on motor data.

**Function:**

Set the rotor leakage reactance of the motor using one of these methods:

1. Run an AMA on a cold motor. The frequency converter will measure the value from the motor.
2. Enter the  $X_2$  value manually. Obtain the value from the motor supplier.
3. Use the  $X_2$  default setting. The frequency converter establishes the setting on the basis of the motor name plate data.

This parameter cannot be adjusted while the motor is running.

**1-35 Main Reactance (Xh)**

**Option:**

Ohm Depending on motor data.

**Function:**

Set the main reactance of the motor using one of these methods:

1. Run an AMA on a cold motor. The frequency converter will measure the value from the motor.
2. Enter the  $X_h$  value manually. Obtain the value from the motor supplier.
3. Use the  $X_h$  default setting. The frequency converter establishes the setting on the basis of the motor name plate data.

This parameter cannot be adjusted while the motor is running.

\* default setting ( ) display text [ ] value for use in communication via serial communication port

— How to Programme —

**1-36 Iron Loss Resistance (R<sub>fe</sub>)**

**Range:**  
1 - 10.000 Ω \*M-TYPE

**Function:**  
Enter the equivalent iron loss resistance (R<sub>Fe</sub>) value to compensate for iron losses in the motor. The R<sub>Fe</sub> value cannot be found by performing an AMA. The R<sub>Fe</sub> value is especially important in torque control applications. If R<sub>Fe</sub> is unknown, leave par. 1-36 on default setting. This parameter cannot be adjusted while the motor is running.

**1-37 d-axis Inductance (L<sub>d</sub>)**

**Range:**  
0.0 - 1000.0 mH \*0.0mH

**Function:**  
Enter the value of the d-axis inductance. Obtain the value from the permanent magnet motor data sheet. This parameter is only active when par. 1-10 *Motor Design* has the value *PM, non-salient SPM* [1] (Permanent Magnet Motor). This parameter is available for FC 302 only. This parameter cannot be adjusted while the motor is running.

**1-39 Motor Poles**

**Option:**  
Depends on motor type  
Value 2 - 100 poles \*4-polemotor

**Function:**  
Enter the number of motor poles.

Poles	~n <sub>n</sub> @ 50 Hz	~n <sub>n</sub> @60 Hz
2	2700 - 2880	3250 - 3460
4	1350 - 1450	1625 - 1730
6	700 - 960	840 - 1153

The table shows the number of poles for normal speed ranges of various motor types. Define motors designed for other frequencies separately. The motor pole value is always an even number, because it refers to the total number of poles, not pairs of poles. The frequency converter creates the initial setting of par. 1-39 based on par. 1-23 *Motor Frequency* and par. 1-25 *Motor Nominal Speed*. This parameter cannot be adjusted while the motor is running.

- **1-4\* LCP Keypad**  
Enable or disable the individual keys on the LCP panel.

\* default setting ( ) display text [ ] value for use in communication via serial communication port

**1-40 Back EMF at 1000 RPM**

**Range:**  
10 - 1000 V \*500V

**Function:**  
Set the nominal back EMF for the motor when running at 1000 RPM. This parameter is only active when par. 1-10 *Motor Design* is set to *PM motor* [1] (Permanent Magnet Motor). This parameter is available for FC 302 only. This parameter cannot be adjusted while the motor is running.

**1-41 Motor Angle Offset**

**Range:**  
0 - 65535 N/A \*ON/A

**Function:**  
Enter the correct offset angle between the PM motor and the index position (single-turn) of the attached encoder or resolver. The value range of 0 - 65535 corresponds to 0 - 2 \* pi (radians). To obtain the offset angle value: After drive start-up apply DC-hold and enter the value of par. 16-20 *Motor Angle* into this parameter. This parameter is only active when par. 1-10 *Motor Design* is set to *PM, non-salient SPM* [1] (Permanent Magnet Motor). This parameter cannot be adjusted while the motor is running.

- **1-5\* Load Indep. Setting**  
Parameters for setting the load-independent motor settings.

**1-50 Motor Magnetisation at Zero Speed**

**Range:**  
0 - 300 % \*100%

**Function:**  
Use this par. along with par. 1-51 *Min Speed Normal Magnetising [RPM]* to obtain a different thermal load on the motor when running at low speed. Enter a value which is a percentage of the rated magnetizing current. If the setting is too low, the torque on the motor shaft may be reduced.



— How to Programme —

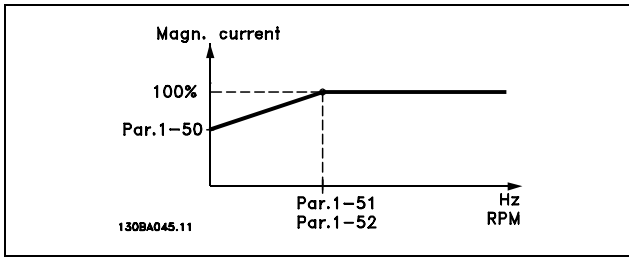

**1-51 Min Speed Normal Magnetising [RPM]**

**Range:**  
10 - 300 RPM \*15RPM

**Function:**  
Set the required speed for normal magnetising current. If the speed is set lower than the motor slip speed, par. 1-50 *Motor Magnetisation at Zero Speed* and par. 1-51 are of no significance. Use this par. along with par. 1-50. See drawing for par. 1-50.

**1-52 Min Speed Normal Magnetising [Hz]**

**Range:**  
0 - 10 Hz \*0 Hz

**Function:**  
Set the required frequency for normal magnetising current. If the frequency is set lower than the motor slip frequency, par. 1-50 *Motor Magnetisation at Zero Speed* and par. 1-51 *Min Speed Normal Magnetising [RPM]*. are inactive. Use this par. along with par. 1-50. See drawing for par. 1-50.

**1-53 Model Shift Frequency**

**Range:**  
4.0 - 50.0 Hz \*6.7Hz

**Function:**  
**Flux Model shift**  
Enter the frequency value for shift between two models for determining motor speed. Choose the value based on settings in par. 1-00 *Configuration Mode* and par. 1-01 *Motor Control Principle*. There are two options: shift between Flux model 1 and Flux model 2; or shift between Variable Current mode and Flux model 2. This parameter is available for FC 302 only. This parameter cannot be adjusted while the motor is running.

**Flux Model 1 – Flux model 2**  
This model is used when par. 1-00 is set to *Speed closed loop* [1] or *Torque* [2] and par. 1-01 is set to *Flux w/motor feedback* [3]. With this parameter it

is possible to make an adjustment of the shifting point where FC 302 changes between Flux model 1 and Flux model 2, which is useful in some sensitive speed and torque control applications.

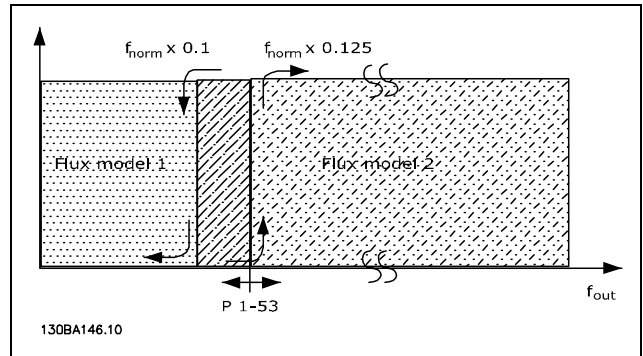

**Par. 1-00 = [1] Speed closed loop or [2] Torque and par. 1-01 = [3] Flux w/motor feedback**

**Variable Current - Flux model - Sensorless**

This model is used when par. 1-00 is set to *Speed open loop* [0] and par. 1-01 is set to *Flux sensorless* [2]. In speed open loop in flux mode, the speed is determined from the current measurement. Below  $f_{norm} \times 0.1$ , the drive runs on a Variable Current model. Above  $f_{norm} \times 0.125$  the frequency converter runs on a Flux model.

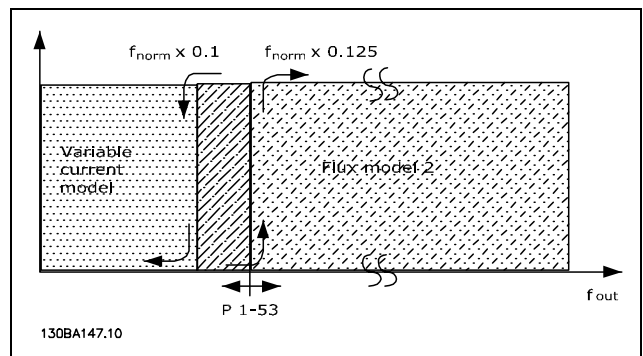

**Par. 1-00 = [0] Speed open loop  
Par. 1-01 = [2] Flux sensorless**

**1-55 U/f Characteristic - U**

**Range:**  
0.0 - max. motor voltage \*Expression limit V

**Function:**  
Enter the voltage at each frequency point to manually form a U/f-characteristic matching the motor.

\* default setting ( ) display text [ ] value for use in communication via serial communication port

— How to Programme —

The frequency points are defined in par. 1-56 *U/f Characteristic - F*. This parameter is an array parameter [0-5] and is only accessible when par. 1-01 *Motor Control Principle* is set to *U/f* [0].

**1-56 U/f Characteristic - F**

**Range:**  
0.0 - max. motor frequency  
\*Expression limit Hz

**Function:**

Enter the frequency points to manually form a U/f-characteristic matching the motor. The voltage at each point is defined in par. 1-55 *U/f Characteristic - U*. This parameter is an array parameter [0-5] and is only accessible when par. 1-01 *Motor Control Principle* is set to *U/f* [0].

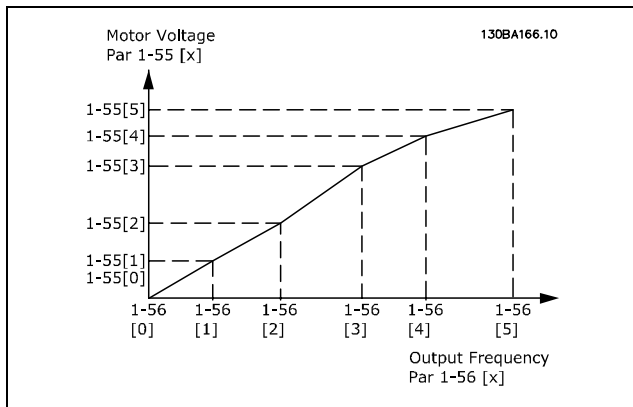

- **1-6\* Load Depend. Setting**  
Parameters for adjusting the load-dependent motor settings.

**1-60 Low Speed Load Compensation**

**Range:**  
-300 - 300% \*100%

**Function:**

Enter the % value to compensate voltage in relation to load when the motor is running at low speed and obtain the optimum U/f characteristic. The motor size determines the frequency range within which this parameter is active.

Motor size	Change over
0.25 kW - 7.5 kW	< 10 Hz

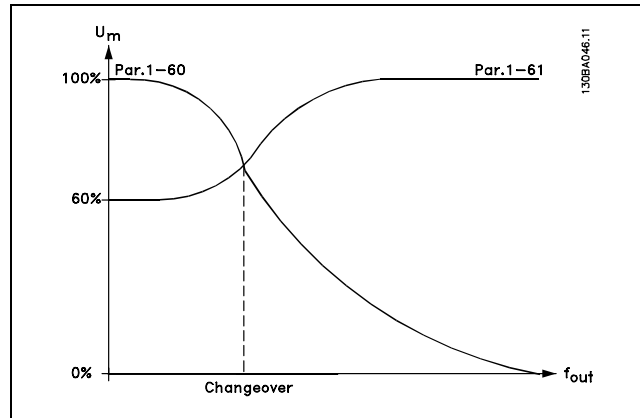

**1-61 High Speed Load Compensation**

**Range:**  
-300 - 300% \*100%

**Function:**

Enter the % value to compensate voltage in relation to load when the motor is running at high speed and obtain the optimum U/f characteristic. The motor size determines the frequency range within which this parameter is active.

Motor size	Change-over
0.25 kW - 7.5 kW	> 10 Hz

**1-62 Slip Compensation**

**Range:**  
-500 - 500 % \*100%

**Function:**

Enter the % value for slip compensation, to compensate for tolerances in the value of  $n_{M,N}$ . Slip compensation is calculated automatically, i.e. on the basis of the rated motor speed  $n_{M,N}$ . This function is not active when par. 1-00 *Configuration Mode* is set to *Speed closed loop* [1] or *Torque* [2] Torque control with speed feedback or when par. 1-01 *Motor Control Principle* is set to *U/f* [0] special motor mode.

**1-63 Slip Compensation Time Constant**

**Range:**  
0.05 - 5.00 s \*0.10s

**Function:**

Enter the slip compensation reaction speed. A high value results in slow reaction, and a low value results in quick reaction. If low-frequency resonance problems arise, use a longer time setting.

\* default setting ( ) display text [ ] value for use in communication via serial communication port

— How to Programme —

**1-64 Resonance Dampening**

**Range:**  
0 - 500 % \*100%

**Function:**  
Enter the resonance dampening value. Set par. 1-64 and par. 1-65 *Resonance Dampening Time Constant* to help eliminate high-frequency resonance problems. To reduce resonance oscillation, increase the value of par. 1-64.

**1-65 Resonance Dampening Time Constant**

**Range:**  
5 - 50 msec. \*5 msec.

**Function:**  
Set par. 1-64 *Resonance Dampening* and par. 1-65 to help eliminate high-frequency resonance problems. Enter the time constant that provides the best dampening.

**1-66 Min. Current at Low Speed**

**Range:**  
0 - Variable Limit % \*100%

**Function:**  
Enter the minimum motor current at low speed, see par. 1-53 *Model Shift Frequency*. Increasing this current improves motor torque at low speed. Par. 1-66 is enabled when par. 1-00 *Configuration Mode = Speed open loop* [0] only. The drive runs with constant current through motor for speeds below 10 Hz. For speeds above 10 Hz, the motor flux model in the drive controls the motor. Par. 4-16 *Torque Limit Motor Mode* and / or par. 4-17 *Torque Limit Generator Mode* automatically adjust par. 1-66. The parameter with the highest value adjusts par. 1-66. The current setting in par. 1-66 is composed of the torque generating current and the magnetizing current. Example: Set par. 4-16 *Torque Limit for Motor Mode* to 100% and set par. 4-17 *Torque Limit for Generating Mode* to 60%. Par. 1-66 automatically adjusts to about 127%, depending on the motor size. This parameter is available for FC 302 only.

**1-67 Load Type**

**Option:**

*Passive load	[0]
Active load	[1]

**Function:**

Select *passive load* [0] for conveyers, fan and pump applications. Select *active load* [1] for hoisting applications. When *active load* [1] is selected, set par. 1-66 *Min. Current at Low Speed* to a level which corresponds with maximum torque. This parameter is available for FC 302 only.

**1-68 Minimum Inertia**

**Range:**  
0 - Variable Limit \*Depending on motor data

**Function:**  
Enter the minimum moment of inertia of the mechanical system. Par. 1-68 and par. 1-69 *Maximum Inertia* are used for pre-adjustment of the Proportional Gain in the speed control, see par. 7-02 *Speed PID Proportional Gain*. This parameter is available for FC 302 only.

**1-69 Maximum Inertia**

**Range:**  
0 - Variable Limit \*Depending on motor data

**Function:**  
Enter the maximum moment of inertia of the mechanical system. Par. 1-68 *Minimum Inertia* and par. 1-69 are used for pre-adjustment of the Proportional Gain in the speed control, see par. 7-02 *Speed PID Proportional Gain*. This parameter is available for FC 302 only.

□ **1-7\* Start Adjustments**  
Parameters for setting special motor start features.

**1-71 Start Delay**

**Range:**  
0.0 - 10.0 s \*0.0s

**Function:**  
This parameter refers to the start function selected in par. 1-72 *Start Function*. Enter the time delay required before commencing acceleration.

\* default setting ( ) display text [ ] value for use in communication via serial communication port

— How to Programme —

**1-72 Start Function**

**Option:**

DC hold/delay time	[0]
DC Brake/delay time	[1]
*Coast/delay time	[2]
Start speed/ current clockwise operation	[3]
Horizontal operation	[4]
VVC <sup>plus</sup> /Flux clockwise	[5]

**Function:**

Select the start function during start delay. This parameter is linked to par. 1-71 *Start Delay*. Select *DC hold/delay time* [0] to energize the motor with a DC holding current (par. 2-00) during the start delay time. Select *DC brake/delay time* [1] to energize the motor with a DC braking current (par. 2-01) during the start delay time. Select *Coast/delay time* [2] to release the shaft coasted converter during the start delay time (inverter off). [3] and [4] are only possible with VVC+. Select *Start speed/current clockwise* [3] to connect the function described in par. 1-74 *Start Speed (RPM)* and par. 1-76 *Start Current* in the start delay time. Regardless of the value applied by the reference signal, the output speed applies the setting of the start speed in par. 1-74 or par. 1-75 and the output current corresponds to the setting of the start current in par. 1-76 *Start Current*. This function is typically used in hoisting applications without counterweight and especially in applications with a Cone-motor, where the start is clockwise, followed by rotation in the reference direction. Select *Horizontal operation* [4] to obtain the function described in par. 1-74 and par. 1-76 during the start delay time. The motor rotates in the reference direction. If the reference signal equals zero (0), par. 1-74 *Start speed (RPM)* is ignored and the output speed equals zero (0). The output current corresponds to the setting of the start current in par. 1-76 *Start current*. Select *VVC+/Flux clockwise* [5] for the function described in par. 1-74 only (*Start speed in the start delay time*). The start current is calculated automatically. This function uses the start speed in the start delay time only. Regardless of the value set by the reference signal, the output speed equals the setting of the start speed in par. 1-74. *Start speed/current clockwise* [3] and *VVCplus/Flux clockwise* [5] are typically used in hoisting applications. *Start speed/current in reference*

*direction* [4] is particularly used in applications with counterweight and horizontal movement.

**1-73 Flying Start [RPM]**

**Option:**

*Off (DISABLE)	[0]
On (ENABLE)	[1]

**Function:**

This function makes it possible to catch a motor which is spinning freely due to a mains drop-out.

Select *Disable* [0] if this function is not required. Select *Enable* [1] to enable the frequency converter to “catch” and control a spinning motor. When par. 1-73 is enabled par. 1-71 *Start Delay* and 1-72 *Start Function* have no function.



**NB!:**

This function is not recommended for hoisting applications.

**1-74 Start Speed [RPM]**

**Range:**

0 - 600 RPM \*ORPM

**Function:**

Set the motor start speed. After the start signal the motor output speed leaps to the set value. This parameter can be used for hoist applications (cone rotor motors). Set the start function in par. 1-72 *Start Function* to [3], [4] or [5], and set a start delay time in par. 1-71 *Start Delay*. A reference signal must be present.

**1-75 Start Speed [Hz]**

**Range:**

0 - 500 Hz \*0Hz

**Function:**

Set the motor start speed. After the start signal the motor output speed leaps to the set value. This parameter can be used for hoist applications (cone rotor motors). Set the start function in par. 1-72 *Start Function* to [3], [4] or [5], and set a start delay time in par. 1-71 *Start Delay*. A reference signal must be present.

**1-76 Start Current**

**Range:**

0.00 - par. 1-24 A \*0.00A

**Function:**

Some motors, such as cone rotor motors, need extra current/starting speed (boost) to disengage

\* default setting ( ) display text [ ] value for use in communication via serial communication port

— How to Programme —

the mechanical brake. Adjust par. 1-74 *Start Speed [RPM]* and par. 1-76 to get this boost. Set the required current value to disengage the mechanical brake. Set par. 1-72 *Start Function* to [3] or [4], and set a start delay time in par. 1-71 *Start Delay*. A reference signal must be present.

□ **1-8\* Stop Adjustments**

Parameters for setting special stop features for the motor.

**1-80 Function at Stop**

**Option:**

*Coast	[0]
DC hold	[1]
Motor check	[2]
Pre-magnetizing	[3]
DC Voltage U0	[4]

**Function:**

Select the drive function after a stop command or after the speed is ramped down to the settings in par. 1-81 *Min Speed for Function at Stop [RPM]*. Select *Coasting* [0] to leave the motor in free mode. Select *DC hold* [1] to energize the motor with a DC holding current (see par. 2-00). Select *Motor check* [2] to check if a motor is been connected. Select *Pre-magnetizing* [3] to build up a magnetic field while the motor is stopped. The motor can now produce a quick torque build-up at start.

**1-81 Min Speed for Function at Stop [RPM]**

**Range:**

0 - 600 RPM \*1RPM

**Function:**

Set the speed at which to activate par. 1-80 *Function at stop*.

**1-82 Min Speed for Function at Stop [Hz]**

**Range:**

0.0 - 500 Hz \*0.0Hz

**Function:**

Set the output frequency at which to activate par. 1-80 *Function at stop*.

**1-83 Precise Stop Function**

**Option:**

*Precise ramp stop	[0]
Counter stop with reset	[1]
Counter stop without reset	[2]
Speed compensated stop	[3]

Speed compensated counter stop with reset	[4]
Speed compensated counter stop without reset	[5]

**Function:**

Select *Precise ramp stop* [0] to achieve high repetitive precision at the stopping point. Select *Counter stop* (with or without reset) to run the frequency converter from receipt of a pulse start signal until the number of pulses programmed by the user in par. 1-84 *Precise Stop Counter Value* has been received at input terminal 29 or input terminal 33. An internal stop signal will activate the normal ramp down time (par. 3-42, 3-52, 3-62 or 3-72). The counter function is activated (starts timing) at the edge of the start signal (when it changes from stop to start). *Speed compensated stop* [3]: To stop at precisely the same point, regardless of the present speed, the stop signal is delayed internally when the present speed is lower than the maximum speed (set in par. 4-13). *Counter stop and Speed-compensated stop* can be combined with or without reset. *Counter stop with reset* [1]. After each precise stop the number of pulses counted during ramp down 0 rpm is reset. *Counter stop without reset* [2]. The number of pulses counted during ramp down to 0 rpm is deducted from the counter value in par. 1-84. This parameter cannot be adjusted while the motor is running.

**1-84 Precise Stop CounterValue**

**Range:**

0 - 99999999 \*100000

**Function:**

Enter the counter value to be used in the integrated precise stop function, par. 1-83. The maximum permissible frequency at terminal 29 or 33 is 110 kHz.

**1-85 Precise Stop Speed Compensation Delay**

**Range:**

1-100 ms \*10 ms

**Function:**

Enter the delay time for sensors, PLCs, etc. for use in par. 1-83 *Precise Stop Function*. In speed compensated stop mode, the delay

\* default setting ( ) display text [ ] value for use in communication via serial communication port

— How to Programme —

time at different frequencies has a major influence on the stop function.

□ **1-9\* Motor Temperature**

Parameters for setting the temperature protection features for the motor.

**1-90 Motor Thermal Protection**

**Option:**

- \*No protection [0]
- Thermistor warning [1]
- Thermistor trip [2]
- ETR warning 1 [3]
- ETR trip 1 [4]
- ETR warning 2 [5]
- ETR trip 2 [6]
- ETR warning 3 [7]
- ETR trip 3 [8]
- ETR warning 4 [9]
- ETR trip 4 [10]

**Function:**

The frequency converter determines the motor temperature for motor protection in two different ways:

- Via a thermistor sensor connected to one of the analog or digital inputs (par. 1-93 *Thermistor Source*).
- Via calculation (ETR = Electronic Terminal Relay) of the thermal load, based on the actual load and time. The calculated thermal load is compared with the rated motor current  $I_{M,N}$  and the rated motor frequency  $f_{M,N}$ . The calculations estimate the need for a lower load at lower speed due to less cooling from the fan incorporated in the motor.

Select *No protection* [0] for a continuously overloaded motor, when no warning or trip of drive is required.

Select *Thermistor warning* [1] to activate a warning when the connected thermistor in the motor reacts in the event of motor over-temperature.

Select *Thermistor trip* [2] to stop (trip) the frequency converter when the connected thermistor in the motor reacts in the event of motor over-temperature.

The thermistor cut-out value is  $> 3 \text{ k}\Omega$ .

Integrate a thermistor (PTC sensor) in the motor for winding protection.

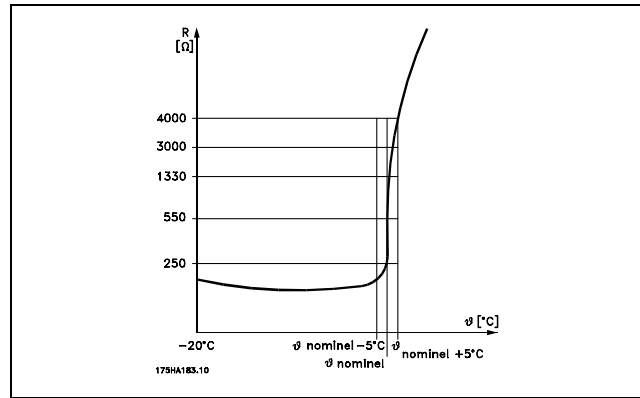

Motor protection can be implemented using a range of techniques: PTC sensor in motor windings; mechanical thermal switch (Klixon type); or Electronic Thermal Relay (ETR). See parameter group 1-9\* *Motor Temperature*.

Using a digital input and 24 V as power supply:  
 Example: The frequency converter trips when the motor temperature is too high  
 Parameter set-up:  
 Set Par. 1-90 *Motor Thermal Protection* to *Thermistor Trip* [2]  
 Set Par. 1-93 *Thermistor Source* to *Digital Input* [6]

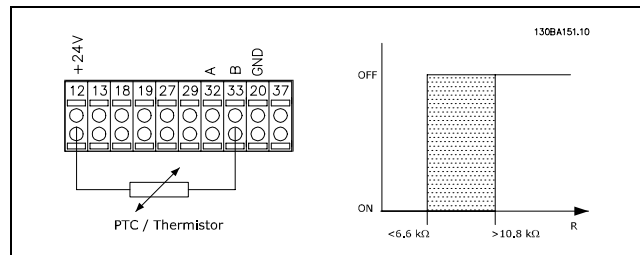

Using a digital input and 10 V as power supply:  
 Example: The frequency converter trips when the motor temperature is too high.  
 Parameter set-up:  
 Set Par. 1-90 *Motor Thermal Protection* to *Thermistor Trip* [2]  
 Set Par. 1-93 *Thermistor Source* to *Digital Input* [6]

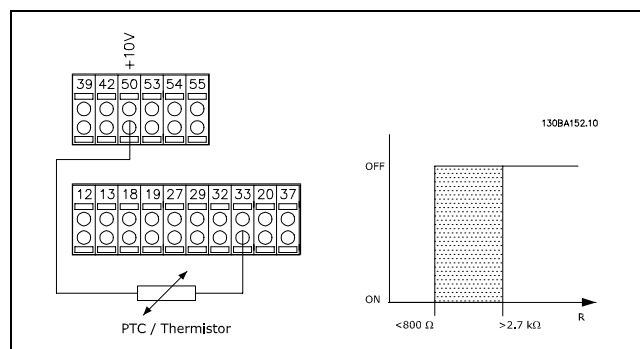

\* default setting ( ) display text [ ] value for use in communication via serial communication port

— How to Programme —

Using an analog input and 10 V as power supply:  
 Example: The frequency converter trips when the motor temperature is too high.

Parameter set-up:

Set Par. 1-90 Motor Thermal Protection to Thermistor Trip [2]

Set Par. 1-93 Thermistor Source to Analog Input 54 [2]

Do not select a reference source.

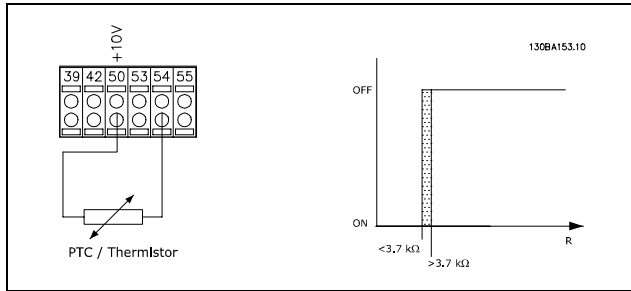
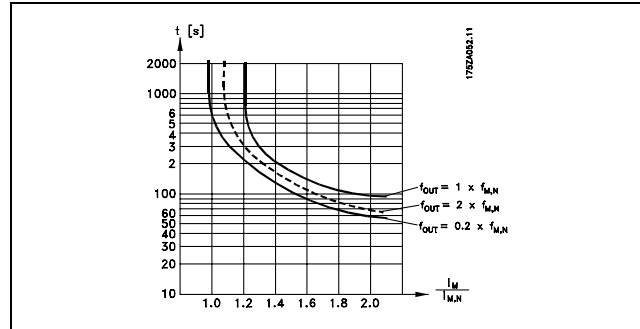

Input Digital/ana- log	Supply Voltage Volt	Threshold Cut-out Values
Digital	24 V	< 6.6 k $\Omega$ - > 10.8 k $\Omega$
Digital	10 V	< 800 $\Omega$ - > 2.7 k $\Omega$
Analog	10 V	< 3.0 k $\Omega$ - > 3.0 k $\Omega$



**NB!:**

Check that the chosen supply voltage follows the specification of the used thermistor element.

Select *ETR Warning 1-4*, to activate a warning on the display when the motor is overloaded.  
 Select *ETR Trip 1-4* to trip the frequency converter when the motor is overloaded.

Programme a warning signal via one of the digital outputs. The signal appears in the event of a warning and if the frequency converter trips (thermal warning).

ETR (Electronic Terminal Relay) functions 1-4 will calculate the load when the set-up where they were selected is active. For example ETR starts calculating when setup 3 is selected. For the North American market: The ETR functions provide class 20 motor overload protection in accordance with NEC.

**1-91 Motor External Fan**

**Option:**

- \*No [0]
- Yes [1]

**Function:**

Select *No* [0] if no external fan is required, i.e. the motor is derated at low speed.  
 Select *Yes* [1] to apply an external motor fan (external ventilation), so no derating of the motor is required at low speed. The graph below is followed if the motor current is lower than nominal motor current (see par. 1-24). If the motor current exceeds nominal current, the operation time still decreases as if no fan were installed.

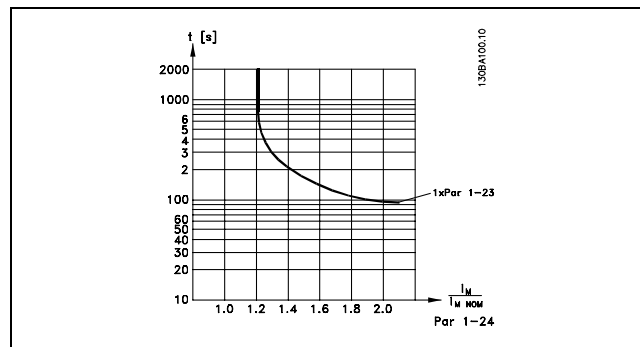

This parameter cannot be adjusted while the motor is running.

**1-93 Thermistor Source**

**Option:**

- \*None [0]
- Analog input 53 [1]
- Analog input 54 [2]
- Digital input 18 [3]
- Digital input 19 [4]
- Digital input 32 [5]
- Digital input 33 [6]

\* default setting ( ) display text [ ] value for use in communication via serial communication port

## — How to Programme —

**Function:**

Select the input to which the thermistor (PTC sensor) should be connected. An analog input option [1] or [2] cannot be selected if the analog input is already in use as a reference source (selected in par. 3-15 *Reference Source 1*, 3-16 *Reference Source 2* or 3-17 *Reference Source 3*).

This parameter cannot be adjusted while the motor is running.



□ **Parameters: Brakes**

□ **2-\*\* Brakes**

Parameter group for setting brake features in the frequency converter.

□ **2-0\* DC-Brakes**

Parameter group for configuring the DC brake and DC hold functions.

**2-00 DC Hold Current**

**Range:**

0 - 100% \*50 %

**Function:**

Enter a value for holding current as a percentage of the rated motor current  $I_{M,N}$  set in par. 1-24 Motor Current. 100% DC holding current corresponds to  $I_{M,N}$ . This parameter holds the motor function (holding torque) or pre-heats the motor. This parameter is active if *DC hold* is selected in par. 1-72 *Start Function* [0] or par. 1-80 *Function at Stop* [1].



**NB!:**

The maximum value depends on the rated motor current.

**NB!:**

Avoid 100 % current for too long. It may damage the motor.

**2-01 DC Brake Current**

**Range:**

0 - 100 % \*50%

**Function:**

Enter a value for current as a percentage of the rated motor current  $I_{M,N}$ , see par. 1-24 *Motor Current*. 100% DC braking current corresponds to  $I_{M,N}$ . DC brake current is applied on a stop command, when the speed is lower than the limit set in par. 2-03 *DC Brake Cut In Speed*; when the DC Brake Inverse function is active; or via the serial communication port. The braking current is active during the time period set in par. 2-02 *DC Braking Time*.



**NB!:**

The maximum value depends on the rated motor current.

**NB!:**

Avoid 100 % current for too long. It may damage the motor.

**2-02 DC Braking Time**

**Range:**

0.0 - 60.0 s. \*10.0s.

**Function:**

Set the duration of the DC braking current set in par. 2-01, once activated.

**2-03 DC Brake Cut In Speed**

**Range:**

0 - par. 4-13 RPM \*0RPM

**Function:**

Set the DC brake cut-in speed for activation of the DC braking current set in par. 2-01, upon a stop command.

□ **2-1\* Brake Energy Funct.**

Parameter group for selecting dynamic braking parameters.

**2-10 Brake Function**

**Option:**

*Off	[0]
Resistor brake	[1]
AC brake	[2]

**Function:**

Select *Off* [0] if no brake resistor is installed. Select *Resistor brake* [1] if a brake resistor is incorporated in the system, for dissipation of surplus brake energy as heat. Connecting a brake resistor allows a higher DC link voltage during braking (generating operation). The Resistor brake function is only active in frequency converters with an integral dynamic brake.

**2-11 Brake Resistor (ohm)**

**Option:**

Ohm Dependsonunitsize.

**Function:**

Set the brake resistor value in Ohms. This value is used for monitoring the power to the brake resistor in par. 2-13 *Brake Power Monitoring*. This parameter is only active in frequency converters with an integral dynamic brake.

\* default setting ( ) display text [ ] value for use in communication via serial communication port

— How to Programme —

**2-12 Brake Power Limit(kW)**

**Range:**

0.001 - Variable Limit kW \*kW

**Function:**

Set the monitoring limit of the brake power transmitted to the resistor.  
 The monitoring limit is a product of the maximum duty cycle (120 sec.) and the maximum power of the brake resistor at that duty cycle.  
 See the formula below.

For 200 - 240 V units:  $P_{resistor} = \frac{390^2 * dutytime}{R * 120}$

For 380 - 480 V units  $P_{resistor} = \frac{778^2 * dutytime}{R * 120}$

For 380 - 500 V units  $P_{resistor} = \frac{810^2 * dutytime}{R * 120}$

For 575 - 600 V units  $P_{resistor} = \frac{943^2 * dutytime}{R * 120}$

This parameter is only active in frequency converters with an integral dynamic brake.

**2-13 Brake Power Monitoring**

**Option:**

- \*Off [0]
- Warning [1]
- Trip [2]
- Warning and Trip [3]

**Function:**

This parameter is only active in frequency converters with an integral dynamic brake.  
 This parameter enables monitoring of the power to the brake resistor. The power is calculated on the basis of the resistance (par. 2-11 *Brake Resistor* (Ohm)), the DC link voltage, and the resistor duty time.  
 Select *Off* [0] if no brake power monitoring is required.  
 Select *Warning* [1] to activate a warning on the display when the power transmitted over 120 s exceeds 100% of the monitoring limit (par. 2-12 *Brake Power Limit (kW)*).  
 The warning disappears when the transmitted power falls below 80% of the monitoring limit.  
 Select *Trip* [2] to trip the frequency converter and display an alarm when the calculated power exceeds 100% of the monitoring limit.  
 Select *Warning and Trip* [3] to activate both of the above, including warning, trip and alarm.  
 If power monitoring is set to *Off* [0] or *Warning* [1], the brake function remains active, even if the monitoring limit is exceeded. This may lead to

thermal overload of the resistor. It is also possible to generate a warning via a relay/digital outputs. The measuring accuracy of the power monitoring depends on the accuracy of the resistance of the resistor (better than ± 20%).

**2-15 Brake Check**

**Option:**

- \*Off [0]
- Warning [1]
- Trip [2]
- Stop and Trip [3]
- AC brake [4]

**Function:**

Select type of test and monitoring function to check the connection to the brake resistor, or whether a brake resistor is present, and then display a warning or an alarm in the event of a fault. The brake resistor disconnection function is tested during power-up, and during braking. However the brake IGBT test is performed when there is no braking. A warning or trip disconnects the brake function. The testing sequence is as follows:

1. The DC link ripple amplitude is measured for 300 ms without braking.
2. The DC link ripple amplitude is measured for 300 ms with the brake turned on.
3. If the DC link ripple amplitude while braking is lower than the DC link ripple amplitude before braking + 1 %. Brake check failed, return a warning or alarm.
4. If the DC link ripple amplitude while braking is higher than the DC link ripple amplitude before braking + 1 %. Brake check OK.

Select *Off* [0] to monitor the brake resistor and the brake IGBT for a short-circuit during operation. If a short-circuit occurs, a warning appears.  
 Select *Warning* [1] to monitor the brake resistor and brake IGBT for a short-circuit, and to run a test for brake resistor disconnection during power-up.  
 Select *Trip* [2], to monitor for a short-circuit or disconnection of the brake resistor, or a short-circuit of the brake IGBT. If a fault occurs the frequency converter cuts out while displaying an alarm (trip locked).  
 Select *Stop and Trip* [3] to monitor for a short-circuit or disconnection of the brake resistor, or a short-circuit of the brake IGBT. If a fault occurs the frequency converter ramps down to coast and then trips. A trip lock alarm is displayed.

\* default setting ( ) display text [ ] value for use in communication via serial communication port

— How to Programme —

Select *AC Brake* [4] to monitor for a short-circuit or disconnection of the brake resistor, or a short-circuit of the brake IGBT. If a fault occurs the frequency converter performs a controlled ramp down. This option is available for FC 302 only.



**NB!:**

NB!: Remove a warning arising in connection with *Off* [0] or *Warning* [1] by cycling the mains supply. The fault must be corrected first. For *Off* [0] or *Warning* [1], the frequency converter keeps running even if a fault is located.

This parameter is only active in frequency converters with an integral dynamic brake.

**2-16 AC Brake Max. Current**

**Range:**  
0 - 200% \* 100%

**Function:**

Enter the maximum permissible current when using AC brake to avoid overheating of motor windings. The AC brake function is available in Flux mode only (FC 302 only).

**2-17 Over-voltage Control**

**Option:**

- \* Disabled [0]
- Enabled (not at stop) [1]
- Enabled [2]

**Function:**

Over-voltage control (OVC) reduces the risk of the drive tripping due to an over voltage on the DC link caused by generative power from the load. Select *Disabled* [0] if no OVC is required. Select *Enabled* [2] to activate OVC. Select *Enabled (not at stop)* [1] to activate OVC except when using a stop signal to stop the frequency converter.

□ **2-2\* Mechanical Brake**

Parameters for controlling operation of an electro-magnetic (mechanical) brake, typically required in hoisting applications. To control a mechanical brake, a relay output (relay 01 or relay 02) or a programmed digital output (terminal 27 or 29) is required. Normally this output must be closed during periods when the drive is unable to 'hold' the motor, e.g. due to an excessive load. Select *Mechanical Brake Control* [32] for applications with an electro-magnetic brake in par. 5-40 *Function Relay*, par. 5-30 *Terminal 27*

*Digital Output*, or par. 5-31 *Terminal 29 Digital Output*. When selecting *Mechanical brake control* [32], the mechanical brake is closed from start up until the output current is above the level selected in par. 2-20 *Release Brake Current*. During stop, the mechanical brake activates when the speed falls below the level specified in par. 2-21 *Activate Brake Speed [RPM]*. If the frequency converter enters an alarm condition or an over-current or over-voltage situation, the mechanical brake immediately cuts in. This is also the case during safe stop.

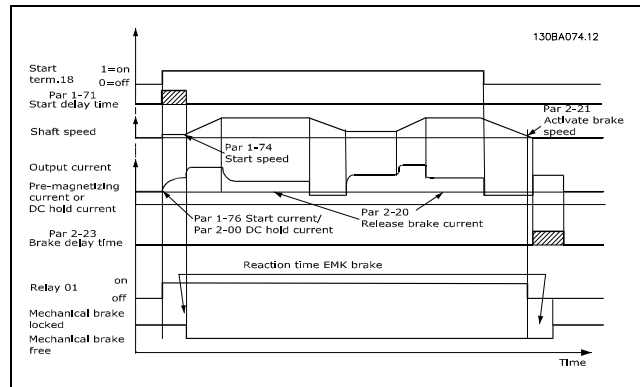

**2-20 Release Brake Current**

**Range:**  
0.00 - par. 16-37 A \* 0.00A

**Function:**

Set the motor current for release of the mechanical brake, when a start condition is present. The upper limit is specified in par. 16-37 *Inv. Max. Current*.

**2-21 Activate Brake Speed [RPM]**

**Range:**  
0 - par. 4-53 RPM \* 0RPM

**Function:**

Set the motor speed for activation of the mechanical brake, when a stop condition is present. The upper speed limit is specified in par. 4-53 *Warning Speed High*.

**2-22 Activate Brake Speed [Hz]**

**Range:**  
0 - Max. speed \* 0Hz

**Function:**

Set the motor frequency for activation of the mechanical brake, when a stop condition is present.

\* default setting ( ) display text [ ] value for use in communication via serial communication port

**2-23 Activate Brake Delay****Range:**

0.0 - 5.0 s \*0.0s

**Function:**

Enter the brake delay time of the coast after ramp-down time. The shaft is held at zero speed with full holding torque. Ensure that the mechanical brake has locked the load before the motor enters coast mode. See *Control of Mechanical Brake section*.

□ **Parameters: Reference/Ramps**

□ **3-\*\* Reference Limits**

Parameters for reference handling, definition of limitations, and configuration of the reaction of the frequency converter to changes.

□ **3-0\* Reference Limits**

Parameters for setting the reference unit, limits and ranges.

**3-00 Reference Range**

**Option:**

Min. - Max	[0]
*-Max - +Max	[1]

**Function:**

Select the range of the reference signal and the feedback signal. Signal values can be positive only, or positive and negative. The minimum limit may have a negative value, unless *Speed closed loop* [1] control is selected in par. 1-00 *Configuration Mode*. Select *Min. - Max* [0] for positive values only. Select *-Max - +Max* [1] for both positive and negative values.

**3-01 Reference/Feedback Unit**

**Option:**

None	[0]
*%	[1]
RPM	[2]
Nm	[4]
bar	[5]
Pa	[6]
PPM	[7]
CYCLE/min	[8]
PULSE/s	[9]
UNITS/s	[10]
UNITS/min	[11]
UNITS/h	[12]
°C	[13]
F	[14]
m <sup>3</sup> /s	[15]
m <sup>3</sup> /min	[16]
m <sup>3</sup> /h	[17]
t/min	[23]
t/h	[24]
m	[25]
m/s	[26]
m/min	[27]
in wg	[29]
gal/s	[30]
gal/min	[31]

gal/h	[32]
lb/s	[36]
lb/min	[37]
lb/h	[38]
lb ft	[39]
ft/s	[40]
ft/min	[41]
l/s	[45]
l/min	[46]
l/h	[47]
kg/s	[50]
kg/min	[51]
kg/h	[52]
ft <sup>3</sup> /s	[55]
ft <sup>3</sup> /min	[56]
ft <sup>3</sup> /h	[57]

**Function:**

Select the unit to be used in Process PID Control references and feedbacks.

**3-02 Minimum Reference**

**Range:**

-100000.000 – par. 3-03 \*0.000 Unit

**Function:**

Enter the Minimum Reference. The Minimum Reference is the lowest value obtainable by summing all references. Minimum Reference is active only when par. 3-00 *Reference Range* is set to *Min.- Max.* [0]. The Minimum Reference unit matches - the choice of configuration in par 1-00 *Configuration Mode*: for *Speed closed loop* [1], RPM; for *Torque* [2], Nm. - the unit selected in par. 3-01 *Reference/Feedback Unit*.

**3-03 Maximum Reference**

**Range:**

Par. 3-02 - 100000.000 \*1500.000 Unit

**Function:**

Enter the Maximum Reference. The Maximum Reference is the highest value obtainable by summing all references. The Maximum Reference unit matches - the choice of configuration in par. 1-00 *Configuration Mode*: for *Speed closed loop* [1], RPM; for *Torque* [2], Nm. - the unit selected in par. 3-01 *Reference/Feedback Unit*.

\* default setting ( ) display text [ ] value for use in communication via serial communication port

— How to Programme —

**3-04 Reference Function**

**Option:**

*Sum	[0]
External/Preset	[1]

**Function:**

Select *Sum* [0] to sum both external and preset reference sources.  
 Select *External/Preset* [1] to use either the preset or the external reference source.

□ **3-1\* References**

Parameters for setting up the reference sources. Select the preset reference(s). Select *Presets ref. bit 0 / 1 / 2* [16], [17] or [18] for the corresponding digital inputs in parameter group 5.1\* *Digital Inputs*.

**3-10 Preset Reference**

Array [8]

**Range:**

-100.00 - 100.00 % \*0.00%

**Function:**

Enter up to eight different preset references (0-7) in this parameter, using array programming. The preset reference is stated as a percentage of the value  $Ref_{MAX}$  (par. 3-03 *Maximum Reference*) or as a percentage of the other external references. If a  $Ref_{MIN}$  0 (Par. 3-02 *Minimum Reference*) is programmed, the preset reference is calculated as a percentage of the full reference range, i.e. on the basis of the difference between  $Ref_{MAX}$  and  $Ref_{MIN}$ . Afterwards, the value is added to  $Ref_{MIN}$ . When using preset references, select *Presets ref. bit 0 / 1 / 2* [16], [17] or [18] for the corresponding digital inputs in parameter group 5.1\* *Digital Inputs*.

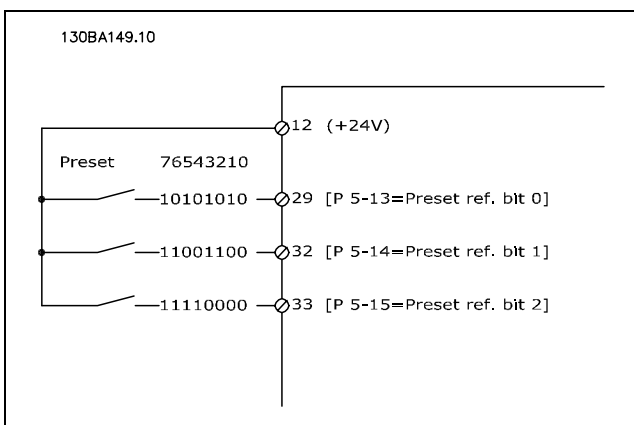

**3-11 Jog Speed [Hz]**

**Range:**

0.0 - par. 4-14 Hz \*5Hz

**Function:**

The jog speed is a fixed output speed at which the frequency converter is running when the jog function is activated.  
 See also par. 3-80.

**3-12 Catch up/slow Down Value**

**Range:**

0.00 - 100.00% \*0.00%

**Function:**

Enter a percentage (relative) value to be either added to or deducted from the actual reference for Catch up or Slow down respectively. If *Catch up* is selected via one of the digital inputs (par. 5-10 to par. 5-15), the percentage (relative) value is added to the total reference. If *Slow down* is selected via one of the digital inputs (par. 5-10 to par. 5-15), the percentage (relative) value is deducted from the total reference. Obtain extended functionality with the DigiPot function. See parameter group 3-9\* *Digital Potentiometer*.

**3-13 Reference Site**

**Option:**

*Linked to Hand / Auto	[0]
Remote	[1]
Local	[2]

**Function:**

Select which reference site to activate. Select *Linked to Hand / Auto* [0] to use the local reference when in Hand mode; or the remote reference when in Auto mode. Select *Remote* [1] to use the remote reference in both Hand mode and Auto mode. Select *Local* [2] to use the local reference in both Hand mode and Auto mode.

**3-14 Preset Relative Reference**

**Range:**

-100.00 - 100.00 % \* 0.00%

**Function:**

Define a fixed value (in %) to be added to the variable value (defined in par. 3-18 *Relative Scaling Reference Source*). The sum of the fixed and variable values (labelled Y in the illustration below) is multiplied with the actual reference (labelled X in the illustration below). This product is then

\* default setting ( ) display text [ ] value for use in communication via serial communication port

— How to Programme —

added to the actual reference ( $X+X*Y/100$ ) to give the resultant actual reference.

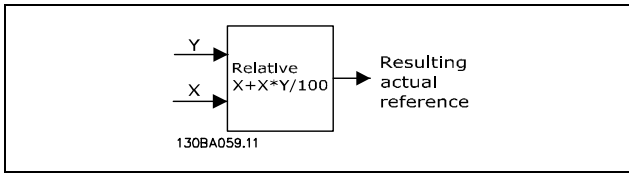

**3-15 Reference Resource 1**

**Option:**

No function	[0]
*Analog input 53	[1]
Analog input 54	[2]
Frequency input 29 (FC 302 only)	[7]
Frequency input 33	[8]
Local bus reference	[11]
Digital pot.meter	[20]
Analog input X30-11	[21]
Analog input X30-12	[22]

**Function:**

Select the reference input to be used for the first reference signal. Par. 3-15, 3-16 and 3-17 define up to three different reference signals. The sum of these reference signals defines the actual reference. This parameter cannot be adjusted while the motor is running.

**3-16 Reference Resource 2**

**Option:**

No function	[0]
Analog input 53	[1]
Analog input 54	[2]
Frequency input 29 (FC 302 only)	[7]
Frequency input 33	[8]
Local bus reference	[11]
*Digital pot.meter	[20]
Analog input X30-11	[21]
Analog input X30-12	[22]

**Function:**

Select the reference input to be used for the second reference signal. Par. 3-15, 3-16 and 3-17 define up to three different reference signals. The sum of these reference signals defines the actual reference. This parameter cannot be adjusted while the motor is running.

**3-17 Reference Resource 3**

**Option:**

No function	[0]
Analog input 53	[1]
Analog input 54	[2]
Frequency input 29 (FC 302 only)	[7]
Frequency input 33	[8]
*Local bus reference	[11]
Digital pot.meter	[20]
Analog input X30-11	[21]
Analog input X30-12	[22]

**Function:**

Select the reference input to be used for the third reference signal. Par. 3-15, 3-16 and 3-17 define up to three different reference signals. The sum of these reference signals defines the actual reference. This parameter cannot be adjusted while the motor is running.

**3-18 Relative Scaling Reference Resource**

**Option:**

*No function	[0]
Analog input 53	[1]
Analog input 54	[2]
Frequency input 29 (FC 302 only)	[7]
Frequency input 33	[8]
Local bus reference	[11]
Digital pot.meter	[20]
Analog input X30-11	[21]
Analog input X30-12	[22]

**Function:**

Select a variable value to be added to the fixed value (defined in par. 3-14 *Preset Relative Reference*). The sum of the fixed and variable values (labelled Y in the illustration below) is multiplied with the actual reference (labelled X in the illustration below). This product is then added to the actual reference ( $X+X*Y/100$ ) to give the resultant actual reference.

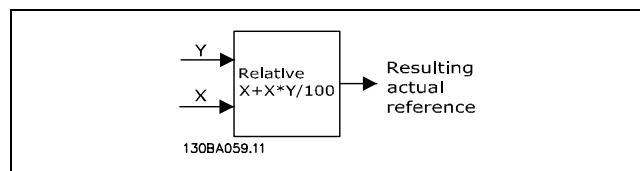

This parameter cannot be adjusted while the motor is running.

— How to Programme —

**3-19 Jog Speed [RPM]**

**Range:**

0 - par. 4-13 RPM \*150RPM

**Function:**

Enter a value for the jog speed  $n_{JOG}$ , which is a fixed output speed. The frequency converter runs at this speed when the jog function is activated. The maximum limit is defined in par. 4-13 *Motor Speed High Limit (Hz)*. See also par. 3-80.

□ **Ramps**

**3-4\* Ramp 1**

For each of four ramps (par. 3-4\*, 3-5\*, 3-6\* and 3-7\*) configure the ramp parameters: ramp type, ramping times (duration of acceleration and deceleration) and level of jerk compensation for S ramps.

Start by setting the linear ramping times corresponding to the figures and formulae.

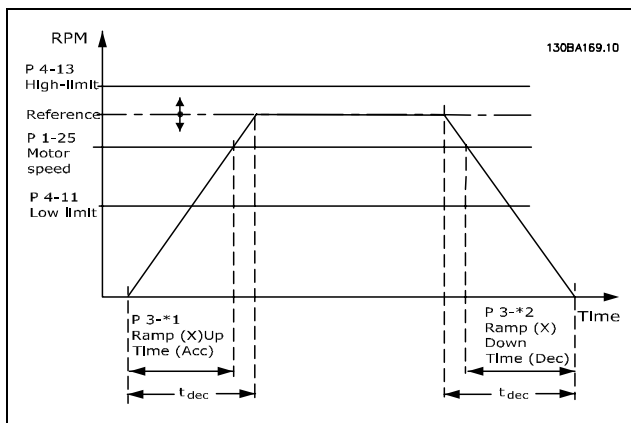

If S-ramps are selected then set the level of non-linear jerk compensation required. Set jerk compensation by defining the proportion of ramp-up and ramp-down times where acceleration and deceleration are variable (i.e. increasing or decreasing). The S-ramp acceleration and deceleration settings are defined as a percentage of the actual ramp time.

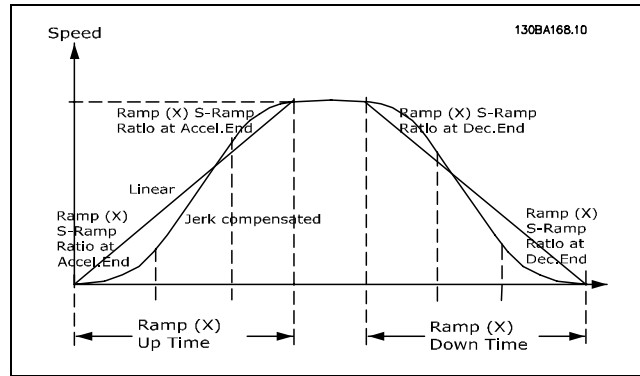

**3-40 Ramp 1 Type**

**Option:**

- \*Linear [0]
- S-ramp [1]

**Function:**

Select the ramp type, depending on requirements for acceleration/deceleration.

A linear ramp will give constant acceleration during ramping. An S-ramp will give non-linear acceleration, compensating for jerk in the application.

**3-41 Ramp 1 Ramp up Time**

**Range:**

0.01 - 3600.00 s \* s

**Function:**

Enter the ramp-up time, i.e. the acceleration time from 0 RPM to the rated motor speed  $n_{M,N}$  (par. 1-25). Choose a ramp-up time such that the output current does not exceed the current limit in par. 4-18 during ramping. The value 0.00 corresponds to 0.01 sec. in speed mode. See ramp-down time in par. 3-42.

$$Par. 3 - 41 = \frac{t_{acc} * n_{norm} [par. 1 - 25]}{\Delta_{ref} [RPM]} [s]$$

**3-42 Ramp 1 Ramp Down Time**

**Range:**

0.01 - 3600.00 s \* s

**Function:**

Enter the ramp-down time, i.e. the deceleration time from the rated motor speed  $n_{M,N}$  (par. 1-25) to 0 RPM. Choose a ramp-down time such that no over-voltage arises in the inverter due to regenerative operation of the motor, and such that the generated current does not exceed the current limit set in par. 4-18. The value

\* default setting ( ) display text [ ] value for use in communication via serial communication port



— How to Programme —

0.00 corresponds to 0.01 s in speed mode.  
See ramp-up time in par. 3-41.

$$Par. 3 - 42 = \frac{t_{acc} * n_{norm} [par. 1 - 25]}{\Delta ref [RPM]} [s]$$

**3-45 Ramp 1 S-ramp Ratio at Accel. Start**

**Range:**

1 - 99% \*50%

**Function:**

Enter the proportion of the total ramp-up time (par. 3-41) in which the acceleration torque increases. The larger the percentage value, the greater the jerk compensation achieved, and thus the lower the torque jerks occurring in the application.

**3-46 Ramp 1 S-ramp Ratio at Accel. End**

**Range:**

1 - 99% \*50%

**Function:**

Enter the proportion of the total ramp-up time (par. 3-41) in which the acceleration torque decreases. The larger the percentage value, the greater the jerk compensation achieved, and thus the lower the torque jerks in the application.

**3-47 Ramp 1 S-ramp Ratio at Decel. Start**

**Range:**

1 - 99% \*50%

**Function:**

Enter the proportion of the total ramp-down time (par. 3-42) where the deceleration torque increases. The larger the percentage value, the greater the jerk compensation achieved, and thus the lower the torque jerks in the application.

**3-48 Ramp 1 S-ramp Ratio at Decel. End**

**Range:**

1 - 99% \*50%

**Function:**

Enter the proportion of the total ramp-down time (par. 3-42) where the deceleration torque decreases. The larger the percentage value, the greater the jerk compensation achieved, and thus the lower the torque jerks in the application.

□ **3-5\* Ramp 2**

Choosing ramp parameters, see 3-4\*.

**3-50 Ramp 2 Type**

**Option:**

\*Linear [0]  
S-ramp [1]

**Function:**

Select the ramp type, depending on requirements for acceleration/deceleration. A linear ramp will give constant acceleration during ramping. An S-ramp will give non-linear acceleration, compensating for jerk in the application.



**NB!:**

If S-ramp [1] is selected and the reference during ramping is changed the ramp time may be prolonged in order to realize a jerk free movement which may result in a longer start or stop way. Additional adjustment of the S-ramp ratios or switching initiators may be necessary.

**3-51 Ramp 2 Ramp up Time**

**Range:**

0.01 - 3600.00 s \*s

**Function:**

Enter the ramp-up time, i.e. the acceleration time from 0 RPM to the rated motor speed  $n_{M,N}$  (par. 1-25). Choose a ramp-up time such that the output current does not exceed the current limit in par. 4-18 during ramping. The value 0.00 corresponds to 0.01 sec. in speed mode. See ramp-down time in par. 3-52.

$$Par.3 - 51 = \frac{t_{acc} * n_{norm} [par.1 - 25]}{\Delta ref [RPM]} [sec]$$

**3-52 Ramp 2 Ramp down Time**

**Range:**

0.01 - 3600.00 s. \*s

**Function:**

Enter the ramp-down time, i.e. the deceleration time from the rated motor speed  $n_{M,N}$  (par. 1-25) to 0 RPM. Choose a ramp-down time such that no over-voltage arises in the inverter due to regenerative operation of the motor, and such that the generated current does not exceed the current limit set in par. 4-18. The value 0.00 corresponds to 0.01 s in speed mode. See ramp-up time in par. 3-51.

$$Par.3 - 52 = \frac{t_{dec} * n_{norm} [par.1 - 25]}{\Delta ref [RPM]} [sec]$$

\* default setting ( ) display text [ ] value for use in communication via serial communication port

— How to Programme —

**3-55 Ramp 2 S-ramp Ratio at Accel. Start**

**Range:**

1 - 99% \*50%

**Function:**

Enter the proportion of the total ramp-up time (par. 3-51) in which the acceleration torque increases. The larger the percentage value, the greater the jerk compensation achieved, and thus the lower the torque jerks in the application.

**3-56 Ramp 2 S-ramp Ratio at Accel. End**

**Range:**

1 - 99% \*50%

**Function:**

Enter the proportion of the total ramp-up time (par. 3-51) in which the acceleration torque decreases. The larger the percentage value, the greater the jerk compensation achieved, and thus the lower the torque jerks in the application.

**3-57 Ramp 2 S-ramp Ratio at Decel. Start**

**Range:**

1 - 99% \*50%

**Function:**

Enter the proportion of the total ramp-down time (par. 3-52) where the deceleration torque increases. The larger the percentage value, the greater the jerk compensation achieved, and thus the lower the torque jerks in the application.

**3-58 Ramp 2 S-ramp Ratio at Decel. End**

**Range:**

1 - 99% \*50%

**Function:**

Enter the proportion of the total ramp-down time (par. 3-52) where the deceleration torque decreases. The larger the percentage value, the greater the jerk compensation achieved, and thus the lower the torque jerks in the application.

□ **3-6\* Ramp 3**

Configure ramp parameters, see 3-4\*.

**3-60 Ramp 3 Type**

**Option:**

\*Linear [0]  
S-ramp [1]

**Function:**

Select the ramp type, depending on requirements for acceleration and deceleration. A linear ramp will give constant acceleration during ramping. An S-ramp will give non-linear acceleration, compensating for jerk in the application.



**NB!:**

If S-ramp [1] is selected and the reference during ramping is changed the ramp time may be prolonged in order to realize a jerk free movement which may result in a longer start or stop way. Additional adjustment of the S-ramp ratios or switching initiators may be necessary.

**3-61 Ramp 3 Ramp up Time**

**Range:**

0.01 - 3600.00 s \*s

**Function:**

Enter the ramp-up time, i.e. the acceleration time from 0 RPM to the rated motor speed  $n_{M,N}$  (par. 1-25). Choose a ramp-up time such that the output current does not exceed the current limit in par. 4-18 during ramping. The value 0.00 corresponds to 0.01 sec. in speed mode. See ramp-down time in par. 3-62.

**3-62 Ramp 3 Ramp down Time**

**Range:**

0.01 - 3600.00 s \*s

**Function:**

Enter the ramp-down time, i.e. the deceleration time from the rated motor speed  $n_{M,N}$  (par. 1-25) to 0 RPM. Choose a ramp-down time such that no over-voltage arises in the inverter due to regenerative operation of the motor, and such that the generated current does not exceed the current limit set in par. 4-18. The value 0.00 corresponds to 0.01 s in speed mode. See ramp-up time in par. 3-61.

$$Par.3 - 62 = \frac{t_{dec} * n_{norm} [par.1 - 25]}{\Delta_{ref} [RPM]} [sec]$$

**3-65 Ramp 3 S-ramp Ratio at Accel. Start**

**Range:**

1 - 99% \*50%

**Function:**

Enter the proportion of the total ramp-up time (par. 3-61) in which the acceleration torque increases.

\* default setting ( ) display text [ ] value for use in communication via serial communication port

— How to Programme —

The larger the percentage value, the greater the jerk compensation achieved, and thus the lower the torque jerks in the application.

**3-66 Ramp 3 S-ramp Ratio at Accel. End**

**Range:**

1 - 99% \*50%

**Function:**

Enter the proportion of the total ramp-up time (par. 3-61) in which the acceleration torque decreases. The larger the percentage value, the greater the jerk compensation achieved, and thus the lower the torque jerks in the application.

**3-67 Ramp 3 S-ramp Ratio at Decel. Start**

**Range:**

1 - 99% \*50%

**Function:**

Enter the proportion of the total ramp-down time (par. 3-62) where the deceleration torque increases. The larger the percentage value, the greater the jerk compensation achieved, and thus the lower the torque jerks in the application.

**3-68 Ramp 3 S-ramp Ratio at Decel. End**

**Range:**

1 - 99% \*50%

**Function:**

Enter the proportion of the total ramp-down time (par. 3-62) where the deceleration torque decreases. The larger the percentage value, the greater the jerk compensation achieved, and thus the lower the torque jerks in the application.

□ **3-7\* Ramp 4**

Configure ramp parameters, see 3-4\*.

**3-70 Ramp 4 Type**

**Option:**

*Linear	[0]
S-ramp	[1]

**Function:**

Select the ramp type, depending on requirements for acceleration and deceleration. A linear ramp will give constant acceleration during ramping. An S-ramp will give non-linear acceleration, compensating for jerk in the application.



**NB!:**

If S-ramp [1] is selected and the reference during ramping is changed the ramp time may be prolonged in order to realize a jerk free movement which may result in a longer start or stop way. Additional adjustment of the S-ramp ratios or switching initiators may be necessary.

**3-71 Ramp 4 Ramp up Time**

**Range:**

0.01 - 3600.00 s \*s

**Function:**

Enter the ramp-up time, i.e. the acceleration time from 0 RPM to the rated motor speed  $n_{M,N}$  (par. 1-25). Choose a ramp-up time such that the output current does not exceed the current limit in par. 4-18 during ramping. The value 0.00 corresponds to 0.01 sec. in speed mode. See ramp-down time in par. 3-72.

$$Par.3 - 71 = \frac{t_{acc} * n_{norm} [par.1 - 25]}{\Delta_{ref} [RPM]} [sec]$$

**3-72 Ramp 4 Ramp Down Time**

**Range:**

0.01 - 3600.00 s \*s

**Function:**

Enter the ramp-down time, i.e. the deceleration time from the rated motor speed  $n_{M,N}$  (par. 1-25) to 0 RPM. Choose a ramp-down time such that no over-voltage arises in the inverter due to regenerative operation of the motor, and such that the generated current does not exceed the current limit set in par. 4-18. The value 0.00 corresponds to 0.01 s in speed mode. See ramp-up time in par. 3-71.

$$Par.3 - 72 = \frac{t_{dec} * n_{norm} [par.1 - 25]}{\Delta_{ref} [RPM]} [sec]$$

**3-75 Ramp 4 S-ramp Ratio at Accel. Start**

**Range:**

1 - 99% \*50%

**Function:**

Enter the proportion of the total ramp-up time (par. 3-71) in which the acceleration torque increases. The larger the percentage value, the greater the jerk compensation achieved, and thus the lower the torque jerks in the application.

\* default setting ( ) display text [ ] value for use in communication via serial communication port

— How to Programme —

**3-76 Ramp 4 S-ramp Ratio at Accel. End**

**Range:**

1 - 99% \*50%

**Function:**

Enter the proportion of the total ramp-up time (par. 3-71) in which the acceleration torque decreases. The larger the percentage value, the greater the jerk compensation achieved, and thus the lower the torque jerks in the application.

**3-77 Ramp 4 S-ramp Ratio at Decel. Start**

**Range:**

1 - 99% \*50%

**Function:**

Enter the proportion of the total ramp-down time (par. 3-72) where the deceleration torque increases. The larger the percentage value, the greater the jerk compensation achieved, and thus the lower the torque jerks in the application.

**3-78 Ramp 4 S-ramp Ratio at Decel. End**

**Range:**

1 - 99% \*50%

**Function:**

Enter the proportion of the total ramp-down time (par. 3-72) where the deceleration torque decreases. The larger the percentage value, the greater the jerk compensation achieved, and thus the lower the torque jerks in the application.

□ **3-8\* Other Ramps**

Configure parameters for special ramps e.g. Jog or Quick Stop.

**3-80 Jog Ramp Time**

**Range:**

0.01 - 3600.00 s \*s

**Function:**

Enter the jog ramp time, i.e. the acceleration/deceleration time between 0 RPM and the rated motor frequency  $n_{M,N}$  (set in par. 1-25 *Motor Nominal Speed*). Ensure that the resultant output current required for the given jog ramp time does not exceed the current limit in par. 4-18. The jog ramp time starts upon activation of a jog signal via the control panel, a selected digital input, or the serial communication port.

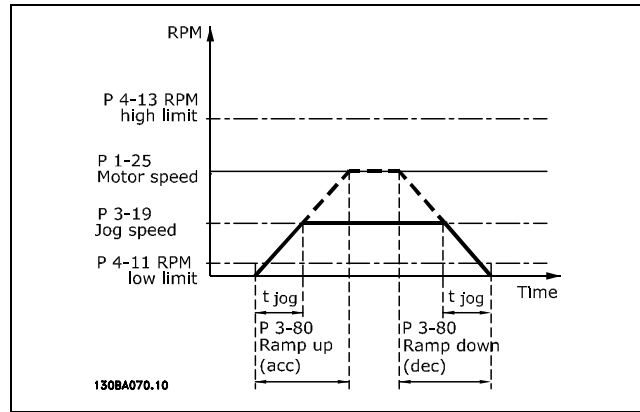

$$Par.3 - 80 = \frac{t_{jog} * n_{norm} [par.1 - 25]}{\Delta jog\ speed [par.3 - 19]} [sec]$$

**3-81 Quick Stop Ramp Time**

**Range:**

0.01 - 3600.00 s \*3s

**Function:**

Enter the quick-stop ramp-down time, i.e. the deceleration time from the rated motor speed to 0 RPM. Ensure that no resultant over-voltage will arise in the inverter due to regenerative operation of the motor required to achieve the given ramp-down time. Ensure also that the generated current required to achieve the given ramp-down time does not exceed the current limit (set in par. 4-18). Quick-stop is activated by means of a signal on a selected digital input, or via the serial communication port.

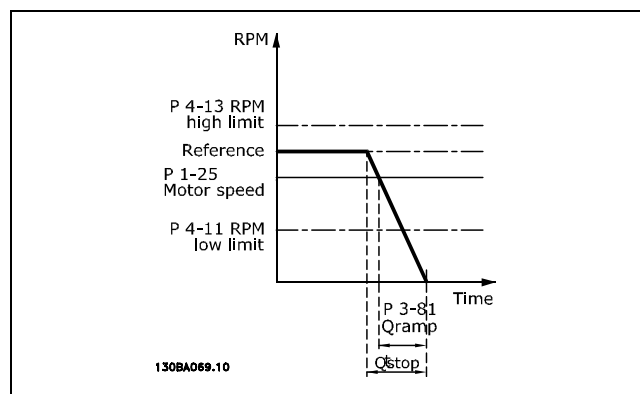

$$Par.3 - 81 = \frac{t_{Qstop} * n_{norm} [par.1 - 25]}{\Delta jog\ ref [RPM]} [sec]$$

\* default setting ( ) display text [ ] value for use in communication via serial communication port

— How to Programme —

□ **3-9\* Digital Pot.Meter**

The digital potentiometer function allows the user to increase or decrease the actual reference by adjusting the set-up of the digital inputs using the functions INCREASE, DECREASE or CLEAR. To activate the function, at least one digital input must be set up to INCREASE or DECREASE.

**3-90 Step Size**

**Range:**

0.01 - 200.00% \*0.10%

**Function:**

Enter the increment size required for INCREASE/DECREASE, as a percentage of the nominal speed set in par. 1-25. If INCREASE / DECREASE is activated the resulting reference will be increased / decreased by the amount set in this parameter.

**3-91 Ramp Time**

**Range:**

0.001 - 3600.00 s \*1.00s

**Function:**

Enter the ramp time, i.e. the time for adjustment of the reference from 0% to 100% of the specified digital potentiometer function (INCREASE, DECREASE or CLEAR). If INCREASE / DECREASE is activated for longer than the ramp delay period specified in par. 3-95 the actual reference will be ramped up / down according to this ramp time. The ramp time is defined as the time used to adjust the reference by the step size specified in par. 3-90 *Step Size*.

**3-92 Power Restore**

**Option:**

\*Off [0]  
On [1]

**Function:**

Select *Off* [0] to reset the Digital Potentiometer reference to 0% after power up. Select *On* [1] to restore the most recent Digital Potentiometer reference at power up.

**3-93 Maximum Limit**

**Range:**

-200 - 200 % \*100%

**Function:**

Set the maximum permissible value for the resultant reference. This is advisable if the

Digital Potentiometer is used for fine tuning of the resulting reference.

**3-94 Minimum Limit**

**Range:**

-200 - 200 % \*-100%

**Function:**

Set the minimum permissible value for the resultant reference. This is advisable if the Digital Potentiometer is used for fine tuning of the resulting reference.

**3-95 Ramp Delay**

**Range:**

0.000 - 3600.00 s \*1.000s

**Function:**

Enter the delay required from activation of the digital potentiometer function until the frequency converter starts to ramp the reference. With a delay of 0 ms, the reference starts to ramp as soon as INCREASE / DECREASE is activated. See also par. 3-91 *Ramp Time*.

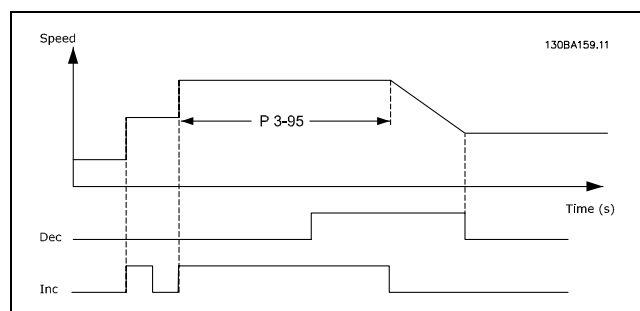
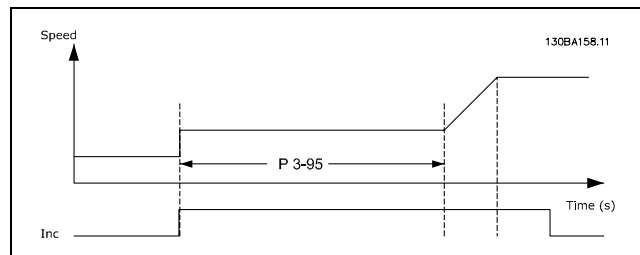

\* default setting ( ) display text [ ] value for use in communication via serial communication port

□ **Parameters: Limits/Warnings**

□ **4-\*\* Motor Limits**

Parameter group for configuring limits and warnings.

□ **4-1\* Motor Limits**

Define torque, current and speed limits for the motor, and the reaction of the frequency converter when the limits are exceeded.

A limit may generate a message on the display. A warning will always generate a message on the display or on the fieldbus. A monitoring function may initiate a warning or a trip, upon which the frequency converter will stop and generate an alarm message.

**4-10 Motor Speed Direction**

**Option:**

- \*Clockwise [0]
- Counter clockwise [1]
- Both directions [2]

**Function:**

Select the motor speed direction(s) required. Use this parameter to prevent unwanted reversing. When par. 1-00 *Configuration Mode* is set to *Process* [3], par. 4-10 is set to *Clockwise* [0] as default. The setting in par. 4-10 does not limit options for setting par.4-13. This parameter cannot be adjusted while the motor is running.

**4-11 Motor Speed Low Limit [RPM]**

**Range:**

0 - par. 4-13 RPM \* 0RPM

**Function:**

Enter the minimum limit for motor speed. The Motor Speed Low Limit can be set to correspond to the manufacturer's recommended minimum motor speed. The Motor Speed Low Limit must not exceed the setting in par. 4-13 *Motor Speed High Limit [RPM]*.

**4-12 Motor Speed Low Limit [Hz]**

**Range:**

0 - par. 4-14 Hz \* 0Hz

**Function:**

Set the *Minimum Motor Speed Limit* corresponding to the minimum output frequency of the motor shaft. Minimum speed cannot exceed the maximum speed in par. 4-14.

**4-13 Motor Speed High Limit [RPM]**

**Range:**

Par. 4-11 - Variable Limit RPM \* 3600. RPM

**Function:**

You can choose to have the maximum motor speed correspond to the highest motor speed.



**NB!:**

The output frequency value of the frequency converter can never be a value higher than 1/10 of the switching frequency.

**4-14 Motor Speed High Limit [Hz]**

**Range:**

Par. 4-12 - Variable limit Hz \* 120 Hz

**Function:**

Set the *Maximum Motor Speed* corresponding to the highest allowed motor speed.



**NB!:**

The output frequency value of the frequency converter can never be a value higher than 1/10 of the switching frequency.

**4-16 Torque Limit Motor Mode**

**Range:**

0.0 - Variable Limit % \* 160.0 %

**Function:**

Sets the torque limit for motor operation. The torque limit is active in the speed range up to the rated motor speed (par. 1-25). To protect the motor from reaching the stalling torque, the default setting is 1.6 x the rated motor torque (calculated value). If a setting in par. 1-00 to par. 1-26 is changed, par. 4-16 to 4-18 are not automatically reset to the default settings.

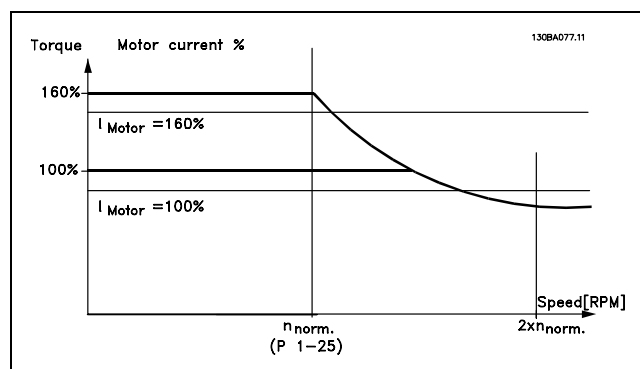

\* default setting ( ) display text [ ] value for use in communication via serial communication port

— How to Programme —

**!** Changing par. 4-16 *Torque Limit Motor Mode* when par. 1-00 is set to *Speed open loop* [0], par. 1-66 *Min Current at Low Speed* is automatically readjusted.

**4-17 Torque Limit Generator Mode**

**Range:**  
0.0 - Variable Limit % \*160.0 %

**Function:**  
Sets the torque limit for generator mode operation. The torque limit is active in the speed range up to the rated motor speed (par. 1-25). See illustration for par. 4-16 as well as par. 14-25 for further details.

**4-18 Current Limit**

**Range:**  
0.0 - Variable Limit % \*160.0 %

**Function:**  
Sets the current limit for motor operation. To protect the motor from reaching the stalling torque, the default setting is 1.6 x the rated motor torque (calculated value). If a setting in par. 1-00 to par. 1-26 is changed, par. 4-16 to par. 4-18 are not automatically reset to the default settings.

**4-19 Max Output Frequency**

**Range:**  
0.0 - 1000.0 Hz \*132.0Hz

**Function:**  
Provides a final limit on the drive output frequency for improved safety in applications where you want to avoid accidental overspeeding. This limit is final in all configurations (independent of the setting in par. 1-00).  
Par. 4-19 cannot be adjusted while the motor is running.

- **4-3\* Motor Feedback Monitoring**  
The parameter group includes monitoring and handling of motor feedback devices as encoders, resolvers etc.

**4-30 Motor Feedback Loss Function**

**Option:**

Disabled	[0]
Warning	[1]
*Trip	[2]

**Function:**  
Select which reaction the frequency converter should take in the case a feedback fault is detected. The selected action will take place

\* default setting ( ) display text [ ] value for use in communication via serial communication port

if the feedback signal differs from the output speed with more than specified in par. 4-31 during the time set in par. 4-32.

**4-31 Motor Feedback Speed Error**

**Range:**  
1-600 RPM \*300RPM

**Function:**  
Select the max allowed tracking error in speed from the calculated and the actual mechanical shaft output speed.

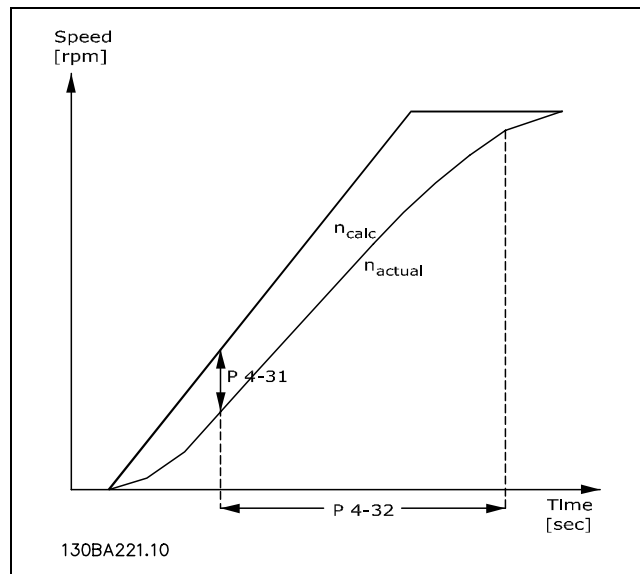

**4-32 Motor Feedback Loss Timeout**

**Range:**  
0.00 - 60.00 sec \*0sec

**Function:**  
Set the timeout value allowing the speed error set in par. 4-31 to be exceeded.

— How to Programme —

□ **4-5\* Adj. Warnings**

Adjustable warning limits for current, speed, reference and feedback.

Warnings are shown on display, programmed output or serial bus.

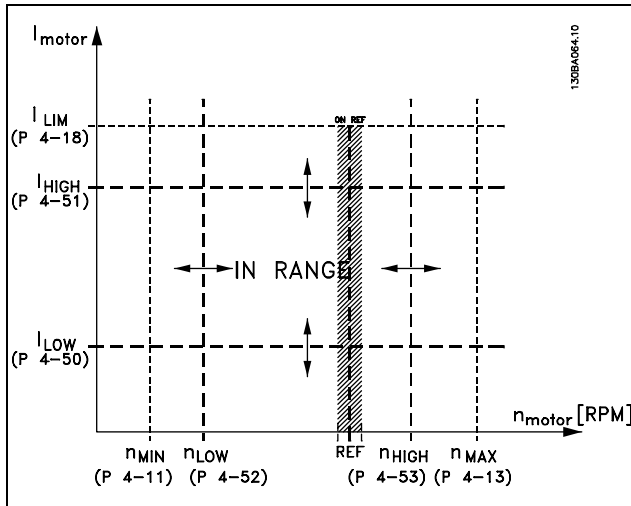

**4-50 Warning Current Low**

**Range:**  
0.00 - par. 4-51 A \*0.00A

**Function:**  
When the motor current is below this limit,  $I_{LOW}$ , the display reads CURRENT LOW. You can programme the signal outputs to produce a status signal on terminal 27 or 29 as well as on relay output 01 or 02.

**4-51 Warning Current High**

**Range:**  
Par. 4-50 - par. 16-37 A \*par. 16-37 A

**Function:**  
Enter the  $I_{HIGH}$  value. When the motor current exceeds this limit ( $I_{HIGH}$ ), the display reads CURRENT HIGH. The signal outputs can be programmed to produce a status signal on terminal 27 or 29 and on relay output 01 or 02. Refer to the drawing in this section.

**4-53 Warning Speed High**

**Range:**  
Par. 4-52 - par. 4-13 RPM \* par. 4-13 RPM

**Function:**  
Enter the  $n_{HIGH}$  value. When the motor speed exceeds this limit ( $n_{HIGH}$ ), the display reads SPEED

HIGH. The signal outputs can be programmed to produce a status signal on terminal 27 or 29 and on relay output 01 or 02. Programme the upper signal limit of the motor speed,  $n_{HIGH}$ , within the normal working range of the frequency converter. Refer to the drawing in this section.

**4-54 Warning Reference Low**

**Range:**  
-999999.999 - 999999.999 \* -999999.999

**Function:**  
Enter the lower reference limit. When the actual reference falls below this limit, the display indicates Ref Low. The signal outputs can be programmed to produce a status signal on terminal 27 or 29 and on relay output 01 or 02.

**4-55 Warning Reference High**

**Range:**  
-999999.999 - 999999.999 \* 999999.999

**Function:**  
Enter the upper reference limit. When the actual reference exceeds this limit, the display reads Ref High. The signal outputs can be programmed to produce a status signal on terminal 27 or 29 and on relay output 01 or 02.

**4-56 Warning Feedback Low**

**Range:**  
-999999.999 - 999999.999 \* -999999.999

**Function:**  
Enter the lower feedback limit. When the feedback falls below this limit, the display reads Feedb Low. The signal outputs can be programmed to produce a status signal on terminal 27 or 29 and on relay output 01 or 02.

**4-57 Warning Feedback High**

**Range:**  
-999999.999 - 999999.999 \* 999999.999

**Function:**  
Enter the upper feedback limit. When the feedback exceeds this limit, the display reads Feedb High. The signal outputs can be programmed to produce a status signal on terminal 27 or 29 and on relay output 01 or 02.

\* default setting ( ) display text [ ] value for use in communication via serial communication port



— How to Programme —

**4-58 Missing Motor Phase Function**

**Option:**

- Off [0]
- \*On [1]

**Function:**

Select *On*, to display an alarm in the event of a missing motor phase. Select *Off*, for no alarm in the event of a missing motor phase. However, if the motor runs on only two phases, it can be damaged by overheating. Retaining the *On* setting is therefore strongly recommended. This parameter cannot be adjusted while the motor is running.

□ **4-6\* Speed Bypass**

Define the Speed Bypass areas for the ramps. Some systems call for avoiding certain output frequencies or speeds, due to resonance problems in the system. A maximum of four frequency or speed ranges can be avoided.

**4-60 Bypass Speed From [RPM]**

Array [4]

**Range:**

0 - par. 4-13 RPM \* 0 RPM

**Function:**

Some systems call for avoiding certain output speeds due to resonance problems in the system. Enter the lower limits of the speeds to be avoided.

**4-61 Bypass Speed From [Hz]**

Array [4]

**Range:**

0 - par. 4-14 Hz \* 0 Hz

**Function:**

Some systems call for avoiding certain output speeds due to resonance problems in the system. Enter the lower limits of the speeds to be avoided.

**4-62 Bypass Speed To [RPM]**

Array [4]

**Range:**

0 - par. 4-13 RPM \* 0RPM

**Function:**

Some systems call for avoiding certain output speeds due to resonance problems in the system. Enter the upper limits of the speeds to be avoided.

**4-63 Bypass Speed To [Hz]**

Array [4]

**Range:**

0 - par. 4-14 Hz \* 0 Hz

**Function:**

Some systems call for avoiding certain output speeds due to resonance problems in the system. Enter the upper limits of the speeds to be avoided.

**4-53 Warning Speed High**

**Range:**

Par. 4-52 - par. 4-13 RPM \* par. 4-13 RPM

**Function:**

Enter the  $n_{HIGH}$  value. When the motor speed exceeds this limit ( $n_{HIGH}$ ), the display reads SPEED HIGH. The signal outputs can be programmed to produce a status signal on terminal 27 or 29 and on relay output 01 or 02. Programme the upper signal limit of the motor speed,  $n_{HIGH}$ , within the normal working range of the frequency converter. Refer to the drawing in this section.

**4-54 Warning Reference Low**

**Range:**

-999999.999 - 999999.999 \* -999999.999

**Function:**

Enter the lower reference limit. When the actual reference falls below this limit, the display indicates Ref Low. The signal outputs can be programmed to produce a status signal on terminal 27 or 29 and on relay output 01 or 02.

**4-55 Warning Reference High**

**Range:**

-999999.999 - 999999.999 \* 999999.999

**Function:**

Enter the upper reference limit. When the actual reference exceeds this limit, the display reads Ref High. The signal outputs can be programmed to produce a status signal on terminal 27 or 29 and on relay output 01 or 02.

\* default setting ( ) display text [ ] value for use in communication via serial communication port

— How to Programme —

**4-56 Warning Feedback Low**

**Range:**  
-999999.999 - 999999.999 \* -999999.999

**Function:**  
Enter the lower feedback limit. When the feedback falls below this limit, the display reads Feedb Low. The signal outputs can be programmed to produce a status signal on terminal 27 or 29 and on relay output 01 or 02.

**4-57 Warning Feedback High**

**Range:**  
-999999.999 - 999999.999 \* 999999.999

**Function:**  
Enter the upper feedback limit. When the feedback exceeds this limit, the display reads Feedb High. The signal outputs can be programmed to produce a status signal on terminal 27 or 29 and on relay output 01 or 02.

**4-58 Missing Motor Phase Function**

**Option:**  
Off [0]  
\*On [1]

**Function:**  
Select *On*, to display an alarm in the event of a missing motor phase. Select *Off*, for no alarm in the event of a missing motor phase. However, if the motor runs on only two phases, it can be damaged by overheating. Retaining the *On* setting is therefore strongly recommended. This parameter cannot be adjusted while the motor is running.

- **4-6\* Speed Bypass**  
Define the Speed Bypass areas for the ramps. Some systems call for avoiding certain output frequencies or speeds, due to resonance problems in the system. A maximum of four frequency or speed ranges can be avoided.

**4-60 Bypass Speed From [RPM]**

Array [4]

**Range:**  
0 - par. 4-13 RPM \* 0 RPM

**Function:**  
Some systems call for avoiding certain output speeds due to resonance problems in the system. Enter the lower limits of the speeds to be avoided.

\* default setting ( ) display text [ ] value for use in communication via serial communication port

**4-61 Bypass Speed From [Hz]**

Array [4]

**Range:**  
0 - par. 4-14 Hz \* 0 Hz

**Function:**  
Some systems call for avoiding certain output speeds due to resonance problems in the system. Enter the lower limits of the speeds to be avoided.

**4-62 Bypass Speed To [RPM]**

Array [4]

**Range:**  
0 - par. 4-13 RPM \* 0RPM

**Function:**  
Some systems call for avoiding certain output speeds due to resonance problems in the system. Enter the upper limits of the speeds to be avoided.

**4-63 Bypass Speed To [Hz]**

Array [4]

**Range:**  
0 - par. 4-14 Hz \* 0 Hz

**Function:**  
Some systems call for avoiding certain output speeds due to resonance problems in the system. Enter the upper limits of the speeds to be avoided.

— How to Programme —

□ **Parameters: Digital In/Out**

□ **5-\*\* Digital In/Out**

Parameter group for configuring the digital input and output.

□ **5-0\* Digital I/O Mode**

Parameters for configuring the IO mode. NPN/PNP and setting up IO to Input or Output.

**5-00 Digital I/O Mode**

**Option:**

*PNP	[0]
NPN	[1]

**Function:**

Digital inputs and programmed digital outputs are pre-programmable for operation either in PNP or NPN systems.  
 Select *PNP* [0] systems for action on positive directional pulses (). PNP systems are pulled down to GND.  
 Select *NPN* [1] systems for action on negative directional pulses (). NPN systems are pulled up to + 24 V, internally in the frequency converter.  
 This parameter cannot be adjusted while the motor is running.

**5-01 Terminal 27 Mode**

**Option:**

*Input	[0]
Output	[1]

**Function:**

Select *Input* [0] to define terminal 27 as a digital input.  
 Select *Output* [1] to define terminal 27 as a digital output.  
 This parameter cannot be adjusted while the motor is running.

**5-02 Terminal 29 Mode**

**Option:**

*Input	[0]
Output	[1]

**Function:**

Select *Input* [0] to define terminal 29 as a digital input.  
 Select *Output* [1] to define terminal 29 as a digital output.  
 This parameter is available for FC 302 only.  
 This parameter cannot be adjusted while the motor is running.

□ **5-1\* Digital Inputs**

Parameters for configuring the input functions for the input terminals.

The digital inputs are used for selecting various functions in the frequency converter. All digital inputs can be set to the following functions:

Digital input function	Select	Terminal
No operation	[0]	All *term 32, 33
Reset	[1]	All
Coast inverse	[2]	All *term 27
Coast and reset inverse	[3]	All
Quick stop inverse	[4]	All
DC-brake inverse	[5]	All
Stop inverse	[6]	All
Start	[8]	All *term 8
Latched start	[9]	All
Reversing	[10]	All *term 19
Start reversing	[11]	All
Enable start forward	[12]	All
Enable start reverse	[13]	All
Jog	[14]	All *term 29
Preset reference on	[15]	All
Preset ref bit 0	[16]	All
Preset ref bit 1	[17]	All
Preset ref bit 2	[18]	All
Freeze reference	[19]	All
Freeze output	[20]	All
Speed up	[21]	All
Speed down	[22]	All
Set-up select bit 0	[23]	All
Set-up select bit 1	[24]	All
Precise stop inverse	[26]	18, 19
Precises start, stop	[27]	18, 19
Catch up	[28]	All
Slow down	[29]	All
Counter input	[30]	29, 33
Pulse input	[32]	29, 33
Ramp bit 0	[34]	All
Ramp bit 1	[35]	All
Mains failure inverse	[36]	All
Latched precise start	[40]	18, 19
Latched precise stop	[41]	18, 19
inverse		
DigiPot Increase	[55]	All
DigiPot Decrease	[56]	All
DigiPot Clear	[57]	All
Counter A (up)	[60]	29, 33
Counter A (down)	[61]	29, 33
Reset Counter A	[62]	All
Counter B (up)	[63]	29, 33
Counter B (down)	[64]	29, 33
Reset Counter B	[65]	All

All = Terminals 18, 19, 27, 29, 32, 33, X30/2, X30/3, X30/4. X30/ are the terminals on MCB 101.  
 Terminal 29 is available in FC 302 only.

Functions dedicated to only one digital input are stated in the associated parameter.

\* default setting ( ) display text [ ] value for use in communication via serial communication port

— How to Programme —

All digital inputs can be programmed to these functions:

- **No operation [0]:** The frequency converter will not react to signals transmitted to the terminal.
- **Reset [1]:** Reset the frequency converter after a TRIP/ALARM. Not all alarms can be reset.
- **Coast inverse [2]** (Default Digital input 27): Coasting stop, inverted input (NC). The frequency converter leaves the motor in free mode. Logic '0' => coasting stop.
- **Coast and reset inverse [3]:** Reset and coasting stop Inverted input (NC). The frequency converter leaves the motor in free mode and resets the drive. Logic '0' => coasting stop and reset.
- **Quick stop inverse [4]:** Inverted input (NC). Generate a stop in accordance with the quick-stop ramp time set in par. 3-81. When the motor stops, the shaft is in free mode. Logic '0' => Quick-stop.
- **DC-brake inverse [5]:** Inverted input for DC braking (NC). Stops the motor by energizing it with a DC current for a certain time period. See par. 2-01 to par. 2-03. The function is only active when the value in par. 2-02 is different from 0. Logic '0' => DC braking.
- **Stop inverse [6]:** Stop Inverted function. Generate a stop function when the selected terminal goes from logical level '1' to '0'. The stop is performed according to the selected ramp time (par. 3-42, par. 3-52, par. 3-62, par. 3-72).



**NB!:**

When the frequency converter is at the torque limit and has received a stop command, it may not stop by itself.

To ensure that the frequency converter stops, configure a digital output to *Torque limit & stop* [27] and connect this digital output to a digital input that is configured as coast.

- **Start [8]** (Default Digital input 18): Select start for a start/stop command. Logic '1' = start, logic '0' = stop.
- **Latched start [9]:** The motor starts, if a pulse is applied for min. 2 ms. The motor stops when Stop inverse is activated.
- **Reversing [10]:** (Default Digital input 19). Change the direction of motor shaft rotation. Select Logic '1' to reverse. The reversing signal only changes the direction of rotation. It does not activate the start function. Select both directions in par. 4-10 *Motor Speed Direction*. The function is not active in *Speed*

*closed loop* [1] or *Torque* [2] control in par. 1-00 *Configuration Mode*.

- **Start reversing [11]:** Use for start/stop and for reversing on the same wire. Signals on start are not allowed at the same time.
- **Enable start forward [12]:** Use if the motor shaft must rotate clockwise at start.
- **Enable start reverse [13]:** Use if the motor shaft must rotate counter-clockwise at start.
- **Jog [14]** (Default Digital input 29): Use for shifting between external reference and preset reference. Select External/preset [2] in par. 2-14. Logic '0' = external references active; Logic '1' = one of the four references is active according to the table below.
- **Preset reference on [15]:** Use for shifting between external reference and preset reference. It is assumed that *External/preset* [1] has been selected in par. 3-04. Logic '0' = external reference active; logic '1' = one of the eight preset references is active.
- **Preset ref bit 0 [16]:** Preset ref. bit 0,1, and 2 enables a choice between one of the eight preset references according to the table below.
- **Preset ref bit 1 [17]:** Same as Preset ref bit 0 [16].
- **Preset ref bit 2 [18]:** Preset ref bit 2 [18]: Same as Preset ref bit 0 [16].

Present ref. bit	2	1	0
Preset ref. 0	0	0	0
Preset ref. 1	0	0	1
Preset ref. 2	0	1	0
Preset ref. 3	0	1	1
Preset ref. 4	1	0	0
Preset ref. 5	1	0	1
Preset ref. 6	1	1	0
Preset ref. 7	1	1	1

- **Freeze ref [19]:** Freeze the actual reference. The frozen reference is now the point of enable/condition for Speed up and Speed down to be used. If Speed up/down is used, the speed change always follows ramp 2 (par. 3-51 and 3-52) in the range 0 - par. 3-03 *Maximum Reference*.
- **Freeze output [20]:** Freeze the actual motor frequency (Hz). The frozen motor frequency is now the point of enable/condition for Speed up and Speed down to be used. If Speed up/down is used, the speed change always

\* default setting ( ) display text [ ] value for use in communication via serial communication port

— How to Programme —

follows ramp 2 (par. 3-51 and 3-52) in the range 0 - par. 1-23 *Motor Frequency*.



**NB!:**

When Freeze output is active, the frequency converter cannot be stopped via a low 'start [13]' signal. Stop the frequency converter via a terminal programmed for Coasting inverse [2] or Coast and reset, inverse.

- **Speed up [21]:** Select Speed up and Speed down if digital control of the up/down speed is desired (motor potentiometer). Activate this function by selecting either Freeze reference or Freeze output. When Speed up is activated for less than 400 msec. the resulting reference will be increased by 0.1 %. If Speed up is activated for more than 400 msec. the resulting reference will ramp according to Ramp 2 in par. 3-41.

	Shut down	Catch up
Unchanged speed	0	0
Reduced by %-value	1	0
Increased by %-value	0	1
Reduced by %-value	1	1

- **Speed down [22]:** Same as Speed up [21].
- **Set-up select bit 0 [23] :** Select Set-up select bit 0 or Select Set-up select bit 1 to select one of the four set-ups. Set par. 0-10 *Active Set-up* to Multi Set-up.
- **Set-up select bit 1 [24]** (Default Digital input 32): Same as Set-up select bit 0 [23].
- **Precise stop inv. [26]:** Prolong the stop signal to give a precise stop independent of speed. Precise stop inverse function is available for terminals 18 or 19.
- **Precise start, stop [27]:** Use when Precise ramp stop [0] is selected in par 1-83 Precise stop function.

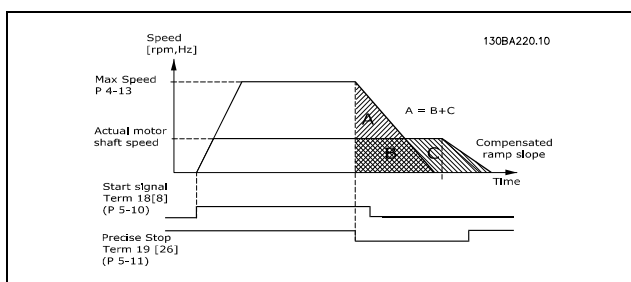

- **Catch up [28]:** Select Catch up/Slow down to increase or reduce the reference value set in par. 3-12.
- **Slow down [29]:** Same as Catch up [28].
- **Counter input [30]:** Select Counter input if you want to use the Precise stop function in par. 1-83 as Counter stop or speed compensated counter stop with or without reset. The counter value must be set in par. 1-84.
- **Pulse input [32]:** Select Pulse input when using a pulse sequence as either reference or feedback. Scaling is done in par. group 5-5\*.
- **Ramp bit 0 [34]**
- **Ramp bit 1 [35]**
- **Mains failure inverse [36]:** Select to activate par. 14-10 *Mains Failure*. Mains failure inverse is active in the Logic .0. situation.
- **Latched Precise Stop inverse [41]:** Send a latched stop signal when the precise stop function is activated in par. 1-83 *Precise Stop Function*. See selection [26]. The Latched Precise stop inverse function is available for terminals 18 or 19.
- **DigiPot Increase [55]:** Use the input as an INCREASE signal to the Digital Potentiometer function described in parameter group 3-9\*
- **DigiPot Decrease [56]:** Use the input as a DECREASE signal to the Digital Potentiometer function described in parameter group 3-9\*
- **DigiPot Clear [57]:** Use the input to CLEAR the Digital Potentiometer reference described in parameter group 3-9\*
- **Counter A [60]:** (Terminal 29 or 33 only) Input for increment counting in the SLC counter.
- **Counter A [61]:** (Terminal 29 or 33 only) Input for decrement counting in the SLC counter.
- **Reset Counter A [62]:** Input for reset of counter A.
- **Counter B [63]:** (Terminal 29 or 33 only) Input for increment counting in the SLC counter.
- **Counter B [64]:** (Terminal 29 or 33 only) Input for decrement counting in the SLC counter.
- **Reset Counter B [65]:** Input for reset of counter B.

**5-10 Terminal 18 Digital Input**

**Function:**

Select the function from the available digital input range.

\* default setting ( ) display text [ ] value for use in communication via serial communication port

— How to Programme —

**5-11 Terminal 19 Digital Input**

**Function:**  
Select the function from the available digital input range.

**5-12 Terminal 27 Digital Input**

**Function:**  
Select the function from the available digital input range.

**5-13 Terminal 29 Digital Input**

**Option:**

*Jog	[14]
Counter A (up)	[60]
Counter A (down)	[61]
Counter B (up)	[63]
Counter B (down)	[64]

**Function:**  
Select the function from the available digital input range and the additional options [60], [61], [63] and [64]. Counters are used in Smart Logic Control functions. This parameter is available for FC 302 only.

**5-14 Terminal 32 Digital Input**

**Option:**

*No operation	[0]
---------------	-----

**Function:**  
Select the function from the available digital input range. Counters are used in Smart Logic Control functions.

**5-15 Terminal 33 Digital Input**

**Option:**

*No operation	[0]
Counter A (up)	[60]
Counter A (down)	[61]
Counter B (up)	[63]
Counter B (down)	[64]

**Function:**  
Select the function from the available digital input range and the additional options [60], [61], [63] and [64]. Counters are used in Smart Logic Control functions.

**5-16 Terminal X30/3 Digital Input**

**Option:**

\*No operation [0]

**Function:**  
This parameter is active when option module MCB 101 is installed in the frequency converter.

**5-17 Terminal X30/4 Digital Input**

**Option:**

\*No operation [0]

**Function:**  
This parameter is active when option module MCB 101 is installed in the frequency converter.

**5-18 Terminal X30/4 Digital Input**

**Option:**

\*No operation [0]

**Function:**  
This parameter is active when option module MCB 101 is installed in the frequency converter.

□ **5-3\* Digital Outputs**

Parameters for configuring the output functions for the output terminals. The 2 solid-state digital outputs are common for terminals 27 and 29. Set the I/O function for terminal 27 in par. 5-01 *Terminal 27 Mode*, and set the I/O function for terminal 29 in par. 5-02 *Terminal 29 Mode*. These parameters cannot be adjusted while the motor is running.

No operation	[0]
Control ready	[1]
Drive ready	[2]
Drive ready / remote control	[3]
Enable / no warning	[4]
VLT running	[5]
Running / no warning	[6]
Run in range / no warning	[7]
Run on reference / no warning	[8]
Alarm	[9]
Alarm or warning	[10]
At torque limit	[11]
Out of current range	[12]
Below current, low	[13]
Above current, high	[14]
Out of range	[15]
Below speed, low	[16]
Above speed, high	[17]
Out of feedback range	[18]
Below feedback low	[19]
Above feedback high	[20]
Thermal warning	[21]
Ready, no thermal warning	[22]
Remote, ready, no thermal warning	[23]
Ready, no over-/ under voltage	[24]
Reverse	[25]

\* default setting ( ) display text [ ] value for use in communication via serial communication port

## — How to Programme —

Bus OK	[26]
Torque limit and stop	[27]
Brake, no brake warning	[28]
Brake ready, no fault	[29]
Brake fault (IGBT)	[30]
Relay 123	[31]
Mechanical brake control	[32]
Safe stop activated (FC 302 only)	[33]
Out of ref range	[40]
Below reference low	[41]
Above reference high	[42]
Bus Ctrl	[45]
Bus Ctrl On at timeout	[46]
Bus Ctrl Off at timeout	[47]
MCO controlled	[51]
Pulse output	[55]
Comparator 0	[60]
Comparator 1	[61]
Comparator 2	[62]
Comparator 3	[63]
Logic Rule 0	[70]
Logic Rule 1	[71]
Logic Rule 2	[72]
Logic Rule 3	[73]
SL Digital Output A	[80]
SL Digital Output B	[81]
SL Digital Output C	[82]
SL Digital Output D	[83]
SL Digital Output E	[84]
SL Digital Output F	[85]
Local reference active	[120]
Remote reference active	[121]
No alarm	[122]
Start command active	[123]
Running reverse	[124]
Drive in hand mode	[125]
Drive in auto mode	[126]

The digital outputs can be programmed with these functions:

- **No operation [0]:** *Default for all digital outputs and relay outputs*
- **Control ready [1]:** The control board receives supply voltage.
- **Drive ready [2]:** The frequency converter is ready for operation and applies a supply signal on the control board.
- **Drive ready / remote control [3]:** The frequency converter is ready for operation and is in Auto On mode.
- **Enable / no warning [4]:** The frequency converter is ready for operation. No start or stop command is been given (start/disable). There are no warnings.
- **VLT running [5]:** The motor is running.
- **Running / no warning [6]:** The output speed is higher than the speed set in par. 1-81Min
- **Speed for Function at Stop [RPM].** The motor is running and there are no warnings.
- **Run in range / no warning [7]:** The motor is running within the programmed current and speed ranges set in par. 4-50 to par. 4-53. There are no warnings.
- **Run on reference / no warning [8]:** The motor runs at reference speed.
- **Alarm [9]:** An alarm activates the output. There are no warnings.
- **Alarm or warning [10]:** An alarm or a warning activates the output.
- **At torque limit [11]:** The torque limit set in par. 4-16 or par. 1-17 has been exceeded.
- **Out of current range [12]:** The motor current is outside the range set in par. 4-18.
- **Below current, low [13]:** The motor current is lower than set in par. 4-50.
- **Above current, high [14]:** The motor current is higher than set in par. 4-51.
- **Out of range [15]**
- **Below speed, low [16]:** The output speed is lower than the setting in par. 4-52.
- **Above speed, high [17]:** The output speed is higher than the setting in par. 4-53.
- **Out of feedback range [18]:** The feedback is outside the range set in par. 4-56 and 4-57.
- **Below feedback low [19]:** The feedback is below the limit set in par. 4-56Warning Feedback Low.
- **Above feedback high [20]:** The feedback is above the limit set in par. 4-57 *Warning Feedback High.*
- **Thermal warning [21]:** The thermal warning turns on when the temperature exceeds the limit in the motor, the frequency converter, the brake resistor, or the thermistor.
- **Ready, no thermal warning [22]:** The frequency converter is ready for operation and there is no over-temperature warning.
- **Remote, ready, no thermal warning [23]:** The frequency converter is ready for operation and is in Auto On mode. There is no over-temperature warning.
- **Ready, no over-/ under voltage [24]:** The frequency converter is ready for operation and the mains voltage is within the specified voltage range (see *General Specifications* section).
- **Reverse [25]:***Reversing. Logic '1' = relay activated, 24 V DC when CW rotation of the motor. Logic '0' = relay not activated, no signal, when CCW rotation of the motor.*

\* default setting ( ) display text [ ] value for use in communication via serial communication port

## — How to Programme —

- **Bus OK [26]:** Active communication (no time-out) via the serial communication port.
- **Torque limit & stop [27]:** Use in performing a coasting stop and in torque limit condition. If the frequency converter has received a stop signal and is at the torque limit, the signal is Logic '0'.
- **Brake, no brake warning [28]:** The brake is active and there are no warnings.
- **Brake ready, no fault [29]:** The brake is ready for operation and there are no faults.
- **Brake fault (IGBT) [30]:** The output is Logic '1' when the brake IGBT is short-circuited. Use this function to protect the frequency converter if there is a fault on the brake modules. Use the output/relay to cut out the main voltage from the frequency converter.
- **Relay 123 [31]:** The relay is activated when Control Word [0] is selected in parameter group 8-\*\*.
- **Mechanical brake control [32]:** Enables control of an external mechanical brake, see description in the section *Control of Mechanical Brake*, and par. group 2-2\*
- **Safe stop activated [33]:** Indicates that the safe stop on terminal 37 has been activated.
- Out of ref range [40]
- Below reference low [41]
- Above reference high [42]
- Bus Ctrl [45]
- Bus Ctrl On at time-out [46]
- Bus Ctrl Off at time-out [47]
- MCO controlled [51]
- Pulse output [55]
- **Comparator 0 [60]:** See par. group 13-1\*. If Comparator 0 is evaluated as TRUE, the output will go high. Otherwise, it will be low.
- **Comparator 1 [61]:** See par. group 13-1\*. If Comparator 2 is evaluated as TRUE, the output will go high. Otherwise, it will be low.
- **Comparator 2 [62]:** See par. group 13-1\*. If Comparator 2 is evaluated as TRUE, the output will go high. Otherwise, it will be low.
- **Comparator 3 [63]:** See par. group 13-1\*. If Comparator 3 is evaluated as TRUE, the output will go high. Otherwise, it will be low.
- **Logic Rule 0 [70]:** See par. group 13-4\*. If Logic Rule 0 is evaluated as TRUE, the output will go high. Otherwise, it will be low.
- **Logic Rule 1 [71]:** See par. group 13-4\*. If Logic Rule 1 is evaluated as TRUE, the output will go high. Otherwise, it will be low.
- **Logic Rule 2 [72]:** See par. group 13-4\*. If Logic Rule 2 is evaluated as TRUE, the output will go high. Otherwise, it will be low.
- **Logic Rule 3 [73]:** See par. group 13-4\*. If Logic Rule 3 is evaluated as TRUE, the output will go high. Otherwise, it will be low.
- **SL Digital Output A [80]:** See par. 13-52 *SL Control Action*. The input will go high whenever the Smart Logic Action [38] *Set dig. out. A high* is executed. The input will go low whenever the Smart Logic Action [32] *Set dig. out. A low* is executed.
- **SL Digital Output B [81]:** See par. 13-52 *SL Control Action*. The input will go high whenever the Smart Logic Action [39] *Set dig. out. A high* is executed. The input will go low whenever the Smart Logic Action [33] *Set dig. out. A low* is executed.
- **SL Digital Output C [82]:** See par. 13-52 *SL Control Action*. The input will go high whenever the Smart Logic Action [40] *Set dig. out. A high* is executed. The input will go low whenever the Smart Logic Action [34] *Set dig. out. A low* is executed.
- **SL Digital Output D [83]:** See par. 13-52 *SL Control Action*. The input will go high whenever the Smart Logic Action [41] *Set dig. out. A high* is executed. The input will go low whenever the Smart Logic Action [35] *Set dig. out. A low* is executed.
- **SL Digital Output E [84]:** See par. 13-52 *SL Control Action*. The input will go high whenever the Smart Logic Action [42] *Set dig. out. A high* is executed. The input will go low whenever the Smart Logic Action [36] *Set dig. out. A low* is executed.
- **SL Digital Output F [85]:** See par. 13-52 *SL Control Action*. The input will go high whenever the Smart Logic Action [43] *Set dig. out. A high* is executed. The input will go low whenever the Smart Logic Action [37] *Set dig. out. A low* is executed.
- **Local reference active [120]:** The output is high when par. 3-13 *Reference Site* = [2] *Local* or when par. 3-13 *Reference Site* = [0] *Linked to hand auto* at the same time as the LCP is in Hand on mode.
- **Remote reference active [121]:** The output is high when par. 3-13 *Reference Site* = *Remote* [1] or *Linked to hand/auto* [0] while the LCP is in [Auto on] mode.
- **No alarm [122]:** The output is high when no alarm is present.
- **Start command active [123]:** The output is high when there is an active Start command (i.e. via digital input bus connection or

\* default setting ( ) display text [ ] value for use in communication via serial communication port



— How to Programme —

[Hand on] or [Auto on], and no Stop or Start command is active.

- **Running reverse [124]:** The output is high when the drive is running counter clockwise (the logical product of the status bits 'running' AND 'reverse').
- **Drive in hand mode [125]:** The output is high when the drive is in Hand on mode (as indicated by the LED light above [Hand on]).
- **Drive in auto mode [126]:** The output is high when the drive is in Hand on mode (as indicated by the LED light above [Auto on]).

**5-30 Terminal 27 Digital Output**

**Option:**

Bus ctrl.	[45]
Bus ctrl. on at timeout	[46]
Bus ctrl. off at timeout	[47]

**Function:**

Select *Bus ctrl.* [45] to control the output via bus. The state of the output is set in par. 5-90. The output state is retained in the event of bus time-out. Select *Bus ctrl. On at time-out* [46] to control the output via bus. The state of the output is set in par. 5-90. In the event of bus time-out the output state is set high (On). Select *Bus ctrl. Off at time-out* [47] to control the output via bus. The state of the output is set in par. 5-90. In the event of bus time-out the output state is set low (Off).

**5-31 Terminal 29 Digital Output**

**Option:**

Bus ctrl.	[45]
Bus ctrl. on at timeout	[46]
Bus ctrl. off at timeout	[47]

**Function:**

Select *Bus ctrl.* [45] to control the output via bus. The state of the output is set in par. 5-90. The output state is retained in the event of bus time-out. Select *Bus ctrl. On at time-out* [46] to control the output via bus. The state of the output is set in par. 5-90. In the event of bus time-out the output state is set high (On). Select *Bus ctrl. Off at time-out* [47] to control the output via bus. The state of the output is set in par. 5-90. In the event of bus time-out the output state is set low (Off).

**5-32 Terminal X30/6 Digital Output (MCB 101)**

**Option:**

*No operation	[0]
---------------	-----

**Function:**

This parameter is active when option module MCB 101 is mounted in the frequency converter.

**5-33 Terminal X30/7 Digital Output (MCB 101)**

**Option:**

*No operation	[0]
---------------	-----

**Function:**

This parameter is active when option module MCB 101 is mounted in the frequency converter.

□ **5-4\* Relays**

Parameters for configuring the timing and the output functions for the relays.

**5-40 Function Relay**

**Option:**

Array	[8]
(Relay )	[0]
(Relay 2)	[1]
Relay 7	[6]
Relay 8	[7]
Relay 9	[8]
Control word bit 11	[36]
Control word bit 12	[37]

Relay 2 is included in FC 302 only. The par. 5-40 options are asforpar.5-30, including options 36 and 37.

**Function:**

Select options to define the function of the relays. Choose between available mechanical relays in an array function.  
 Example: par. 5-4\* => 'OK' => Function Relay => 'OK' => [0] => 'OK' => select function Relay no. 1 has array no. [0]. Relay no. 2 has array no. [1].  
 When relay option MCB 105 is fitted in the drive, the following selection of relays will be available:  
 Relay 7 => Par. 5-40 [6]  
 Relay 8 => Par. 5-40 [7]  
 Relay 9 => Par. 5-40 [8]

Select the relay function options from the same list as for solid state output functions, see par. 5-3\*, and the following:  
*Control word bit 11* [36]: Bit 11 in the control word controls relay 01. See section *Control*

\* default setting ( ) display text [ ] value for use in communication via serial communication port

— How to Programme —

*Word According to FC Profile (CTW).* This option is available in par. 5-40 only.

*Control word bit 12 [37]:* Bit 12 in the control word controls relay 02. See section *Control Word According to FC Profile (CTW).*

**5-41 On Delay, Relay**

Array [8] (Relay 1 [0], Relay 2 [1], Relay 7 [6], Relay 8 [7], Relay 9 [8])

**Range:**

0.01 - 600.00 s \*0.01s

**Function:**

Enter the delay of the relay cut-in time. Select one of available mechanical relays and MCO 105 in an array function. See par. 5-40.

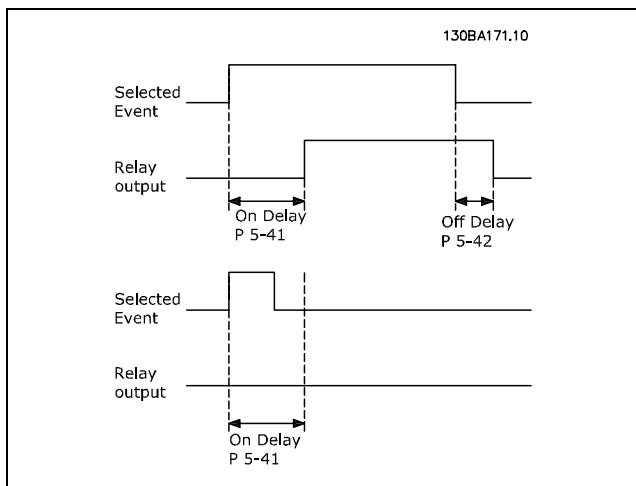

**5-42 Off Delay, Relay**

Array [8] (Relay 1 [0], Relay 2 [1], Relay 7 [6], Relay 8 [7], Relay 9 [8])

**Range:**

0.01 - 600.00 s. \*0.01s

**Function:**

Enter the delay of the relay cut-out time. Select one of available mechanical relays and MCO 105 in an array function. See par. 5-40.

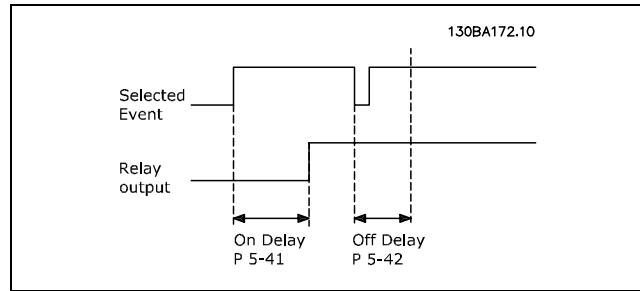

If the Selected Event condition changes before the on- or off delay timer expires, the relay output is unaffected.

□ **5-5\* Pulse Input**

The pulse input parameters are used to define an appropriate window for the impulse reference area by configuring the scaling and filter settings for the pulse inputs. Input terminals 29 or 33 act as frequency reference inputs. Set terminal 29 (par. 5-13) or terminal 33 (par. 5-15) to *Pulse input [32]*. If terminal 29 is used as an input, then set par. 5-01 to *Input [0]*.

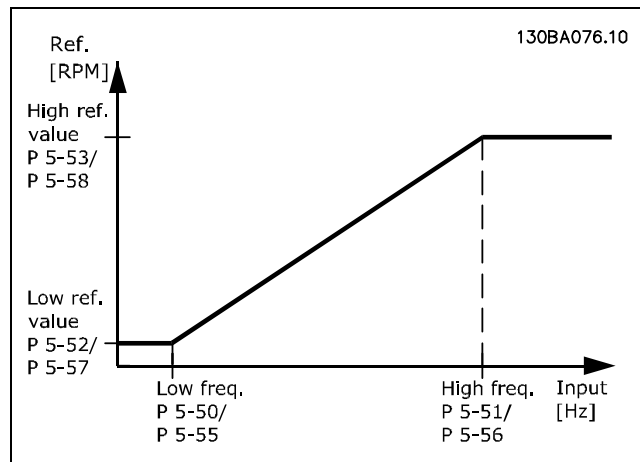

**5-50 Term. 29 Low Frequency**

**Range:**

0 - 110000 Hz \*100Hz

**Function:**

Enter the low frequency limit corresponding to the low motor shaft speed (i.e. low reference value) in par. 5-52. Refer to the diagram in this section. This parameter is available for FC 302 only.

\* default setting ( ) display text [ ] value for use in communication via serial communication port

## — How to Programme —

**5-51 Term. 29 High Frequency****Range:**

0 - 110000 Hz \*100Hz

**Function:**

Enter the high frequency limit corresponding to the high motor shaft speed (i.e. high reference value) in par. 5-53.

This parameter is available for FC 302 only.

**5-52 Term. 29 Low Ref./Feedb. Value****Range:**

-1000000.000 - par. 5-53 \* 0.000

**Function:**

Enter the low reference value limit for the motor shaft speed [RPM]. This is also the lowest feedback value, see also par. 5-57. Set terminal 29 to digital output (par. 5-02 = *Output* [1] and par. 5-13 = applicable value).

This parameter is available for FC 302 only.

**5-53 Term. 29 High Ref./Feedb. Value****Range:**

Par. 5-52 - 1000000.000 \*1500.000

**Function:**

Enter the high reference value [RPM] for the motor shaft speed and the high feedback value, see also par.5-58. Select terminal 29 as a digital output (par. 5-02 = *Output* [1] and par. 5-13 = applicable value). This parameter is available for FC 302 only.

**5-54 Pulse Filter Time Constant #29****Range:**

1 - 1000 ms \*100ms

**Function:**

Enter the pulse filter time constant. The pulse filter dampens oscillations of the feedback signal, which is an advantage if there is a lot of noise in the system. A high time constant value results in better dampening but also increases the time delay through the filter. This parameter is available for FC 302 only. This parameter cannot be adjusted while the motor is running.

**5-55 Term. 33 Low Frequency****Range:**

0 - 110000 Hz \*100Hz

**Function:**

Enter the low frequency corresponding to the low motor shaft speed (i.e. low reference value) in par. 5-57. Refer to the diagram in this section.

**5-56 Term. 33 High Frequency****Range:**

0 - 110000 Hz \*100Hz

**Function:**

Enter the high frequency corresponding to the high motor shaft speed (i.e. high reference value) in par. 5-58.

**5-57 Term. 33 Low Ref./Feedb. Value****Range:**

-100000.000 - par. 5-58) \*0.000

**Function:**

Enter the low reference value [RPM] for the motor shaft speed. This is also the low feedback value, see also par.5-52.

**5-58 Term. 33 High Ref./Feedb. Value****Range:**

Par. 5-57 - 100000.000 \*1500.000

**Function:**

Enter the high reference value [RPM] for the motor shaft speed. See also par. 5-53 *Term. 29 High Ref./Feedb. Value*.

**5-59 Pulse Filter Time Constant #33****Range:**

1 - 1000 ms \* 100ms

**Function:**

Enter the pulse filter time constant. The low-pass filter reduces the influence on and dampens oscillations on the feedback signal from the control. This is an advantage, e.g. if there is a great amount on noise in the system. This parameter cannot be adjusted while the motor is running.

□ **5-6\* Pulse Outputs**

Parameters for configuring the scaling and output functions of pulse outputs. The pulse outputs are designated to terminals 27 or 29. Select terminal 27 output in par. 5-01 and terminal 29 output in par. 5-02.

— How to Programme —

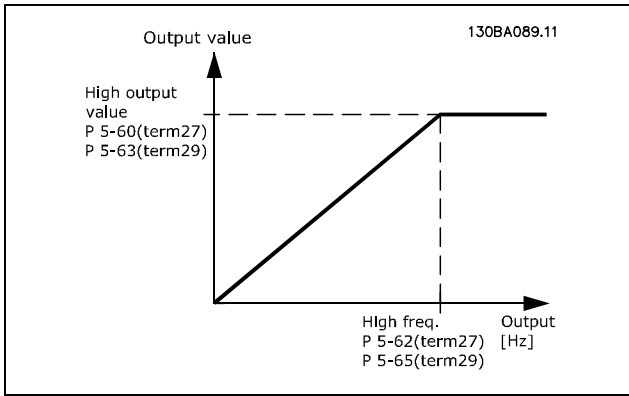

Options for readout output variables:

*No operation	[0]
MCO controlled	[51]
Output frequency	[100]
Reference	[101]
Feedback	[102]
Motor current	[103]
Torque relative to limit	[104]
Torque relative to rated	[105]
Power	[106]
Speed	[107]
Torque	[108]

**Function:**

Parameters for configuring the scaling and output functions of pulse outputs. The pulse outputs are designated to terminals 27 or 29. Select terminal 27 output in par. 5-01 and terminal 29 output in par. 5-02.

**5-60 Terminal 27 Pulse Output Variable**

**Option:**

\*No operation [0]

**Function:**

Select the variable for viewing on the terminal 27 display. This parameter cannot be adjusted while the motor is running.

**5-62 Pulse Output Maximum Frequency #27**

**Range:**

0 - 32000 Hz \*5000Hz

**Function:**

Set the maximum frequency for terminal 27, corresponding to the output variable selected in par. 5-60. This parameter cannot be adjusted while the motor is running.

**5-63 Terminal 29 Pulse Output Variable**

**Option:**

\*No operation [0]

**Function:**

Select the variable for viewing on the terminal 29 display. This parameter is available for FC 302 only. This parameter cannot be adjusted while the motor is running.

**5-65 Pulse Output Maximum Frequency #29**

**Range:**

0 - 32000 Hz \*5000Hz

**Function:**

Set the maximum frequency for terminal 29 corresponding to the output variable set in par. 5-63. This parameter cannot be adjusted while the motor is running.

**5-66 Terminal X30/6 Pulse Output Variable**

**Option:**

\*No operation [0]

**Function:**

Select the variable for read-out on terminal X30/6. This parameter cannot be adjusted while the motor is running. This parameter is active when option module MCB 101 is installed in the frequency converter.

**5-68 Pulse Output Maximum Frequency #X30/6**

**Option:**

\*No operation [0]

**Function:**

Select the maximum frequency on terminal X30/6 referring to the output variable in par. 5-66. This parameter cannot be adjusted while the motor is running. This parameter is active when option module MCB 101 is mounted in the frequency converter.

\* default setting ( ) display text [ ] value for use in communication via serial communication port

— How to Programme —

□ **5-7\* 24 V Encoder Input**

Parameters for configuring the 24V encoder. Connect the 24 V encoder to terminal 12 (24 V DC supply), terminal 32 (Channel A), terminal 33 (Channel B), and terminal 20 (GND). The digital inputs 32/33 are active for encoder inputs when *24V encoder* is selected in par. 1-02 and par. 7-00. The encoder used is a dual channel (A and B) 24 V type. Max input frequency: 110 kHz.

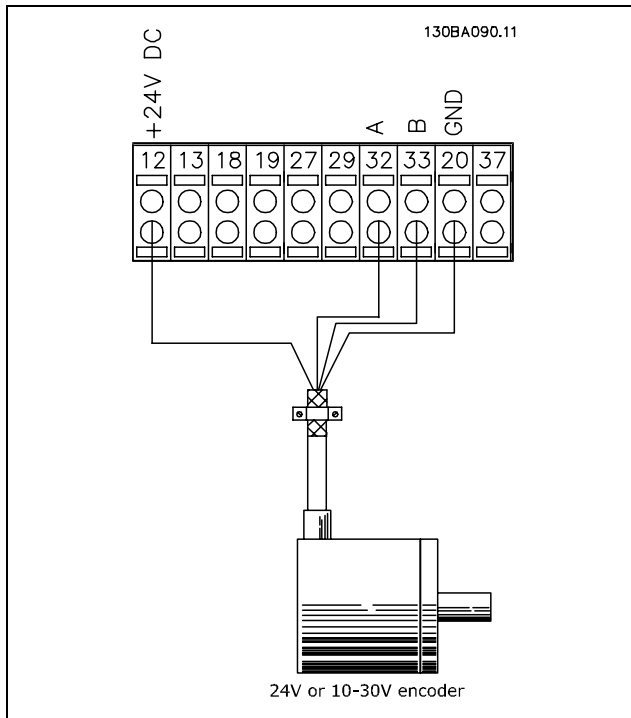

**5-70 Term 32/33 Pulses per Revolution**

**Range:**  
128 - 4096 PPR \*1024PPR

**Function:**  
Set the encoder pulses per revolution on the motor shaft. Read the correct value from the encoder. This parameter cannot be adjusted while the motor is running.

**5-71 Term 32/33 Encoder Direction**

**Option:**  
\*Clockwise [0]  
Counter clockwise [1]

**Function:**  
Change the detected encoder rotation direction without changing the wiring to the encoder. Select *Clockwise* [0] to set channel A 90° (electrical degrees) behind channel B upon clockwise

rotation of the encoder shaft. Select *Counter clockwise* [1] to set channel A 90° (electrical degrees) ahead of channel B upon clockwise rotation of the encoder shaft. This parameter cannot be adjusted while the motor is running.

**5-72 Term 32/33 Gear Numerator**

**Range:**  
1.0 - 60000 N/A \*1N/A

**Function:**  
Enter the numerator value for a gear ratio between encoder and driving shaft. The numerator corresponds to the encoder shaft and the denominator corresponds to the driving shaft. Use this parameter to set a multiplier on the encoder feedback to compensate a ratio of encoder turns to motor turns.  
Example:  
Speed on the encoder shaft = 1000 RPM and speed on the driving shaft is 3000 RPM:  
Par. 5-72 = 1000 and par. 5-73 = 3000, or par. 5-72 = 1 and par. 5-73 = 3.  
If the motor control principle is *Flux w motor feedback* [3] in par. 1-01, the gear ratio between motor and encoder must be 1:1. (No gear). This parameter cannot be adjusted while the motor is running.

**5-73 Term 32/33 Gear Denominator**

**Range:**  
1.0 - 60000 N/A \*1N/A

**Function:**  
Enter the denominator value for a gear ratio between encoder and driving shaft. The numerator corresponds to the encoder shaft and the denominator corresponds to the driving shaft. See also par. 5-72. This parameter cannot be adjusted while the motor is running.

□ **5-9\* Bus Controlled**

This parameter group selects digital and relay outputs via a fieldbus setting.

**5-90 Digital & Relay Bus Control**

**Range:**  
0 - FFFFFFFF

**Function:**  
This parameter holds the state of the digital outputs and relays that is controlled by bus.

\* default setting ( ) display text [ ] value for use in communication via serial communication port

## — How to Programme —

A logical '1' indicates that the output is high or active.  
 A logical '0' indicates that the output is low or inactive.

Bit 0	CC Digital Output Terminal 27
Bit 1	CC Digital Output Terminal 29
Bit 2	GPIO Digital Output Terminal X 30/6
Bit 3	GPIO Digital Output Terminal X 30/7
Bit 4	CC Relay 1 output terminal
Bit 5	CC Relay 2 output terminal
Bit 6	Option B Relay 1 output terminal
Bit 7	Option B Relay 2 output terminal
Bit 8	Option B Relay 3 output terminal
Bit 9-15	Reserved for future terminals
Bit 16	Option C Relay 1 output terminal
Bit 17	Option C Relay 2 output terminal
Bit 18	Option C Relay 3 output terminal
Bit 19	Option C Relay 4 output terminal
Bit 20	Option C Relay 5 output terminal
Bit 21	Option C Relay 6 output terminal
Bit 22	Option C Relay 7 output terminal
Bit 23	Option C Relay 8 output terminal
Bit 24-31	Reserved for future terminals

□ **Parameters: Analog In/Out**

□ **6-\*\* Analog In/Out**

Parameter group for configuration of the analog input and output.

□ **6-0\* Analog I/O Mode**

Parameter group for setting up the analog I/O configuration.

FC 300 is equipped with 2 analog inputs: Terminal 53 and 54. The analog inputs on FC 302 can freely be allocated to either voltage (-10 V - +10 V) or current input (0/4 - 20 mA)



**NB!:**

Thermistors may be connected to either an analog or a digital input.

The output frequency of the frequency converter can be:

The output frequency of the frequency converter can be:

- [1] frozen at the present value
- [2] overruled to stop
- [3] overruled to jog speed
- [4] overruled to max. speed
- [5] overruled to stop with subsequent trip

This parameter cannot be adjusted while the motor is running.

□ **6-1\* Analog Input 1**

Parameters for configuring the scaling and limits for analog input 1 (terminal 53).

**6-00 Live Zero Timeout Time**

**Range:**

1 - 99 s \* 10s

**Function:**

Enter the Live Zero Time-out time period. Live Zero Time-out Time is active for analog inputs, i.e. terminal 53 or terminal 54, allocated to current and used as reference or feedback sources. If the reference signal value associated with the selected current input falls below 50% of the value set in par. 6-10, par. 6-12, par. 6-20 or par. 6-22 for a time period longer than the time set in par. 6-00, the function selected in par. 6-01 will be activated.

**6-01 Live Zero Timeout Function**

**Option:**

- \*Off [0]
- Freeze Output [1]
- Stop [2]
- Jogging [3]
- Max. speed [4]
- Stop and trip [5]

**Function:**

Select the time-out function. The function set in par. 6-01 will be activated if the input signal on terminal 53 or 54 is below 50% of the value in par. 6-10, par. 6-12, par. 6-20 or par. 6-22 for a time period defined in par. 6-00. If several time-outs occur simultaneously, the frequency converter prioritises the time-out functions as follows:

1. Par. 6-01 *Live Zero Time-out Function*
2. Par. 5-74 *Encoder Loss Function*
3. Par. 8-04 *Control-word Time-out Function*

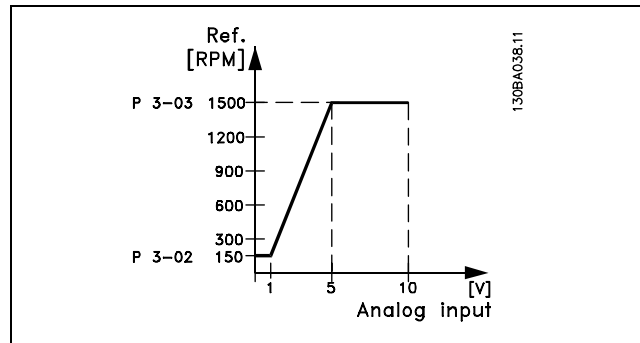

**6-10 Terminal 53 Low Voltage**

**Range:**

-10.0 - par. 6-11 \* 0.07V

**Function:**

Enter the low voltage value. This analog input scaling value should correspond to the minimum reference value, set in par. 3-02. See also the section *Reference Handling*.

**6-11 Terminal 53 High Voltage**

**Range:**

Par. 6-10 to 10.0 V \* 10.0V

**Function:**

Enter the high voltage value. This analog input scaling value should correspond to the maximum reference value, set in par. 3-03.

\* default setting ( ) display text [ ] value for use in communication via serial communication port

— How to Programme —

**6-12 Terminal 53 Low Current**

**Range:**

0.0 to par. 6-13 mA \*0.14mA

**Function:**

Enter the low current value. This reference signal should correspond to the minimum reference value, set in par. 3-02. The value must be set at >2 mA in order to activate the Live Zero Time-out Function in par. 6-01.

**6-13 Terminal 53 High Current**

**Range:**

Par. 6-12 to - 20.0 mA \* 20.0 mA

**Function:**

Enter the value of the reference signal that corresponds to the maximum reference value, set in par. 3-03.

**6-14 Terminal 53 Low Ref./Feedb. Value**

**Range:**

-1000000.000 to par. 6-15 \* 0.000 Unit

**Function:**

Enter the analog input scaling value that corresponds to the minimum reference feedback value set in par. 3-02.

**6-15 Terminal 53 High Ref./Feedb. Value**

**Range:**

Par. 6-14 to 1000000.000 \* 1500.000 Unit

**Function:**

Enter the analog input scaling value that corresponds to the maximum reference feedback value set in par. 3-03.

**6-16 Terminal 53 Filter Time Constant**

**Range:**

0.001 - 10.000 s \*0.001s

**Function:**

Enter the time constant. This is a first-order digital low pass filter time constant for suppressing electrical noise in terminal 53. A high time constant value improves dampening but also increases the time delay through the filter. This parameter cannot be adjusted while the motor is running.

□ **6-2\* Analog Input 2**

Parameters for configuring the scaling and limits for analog input 2 (terminal 54).

**6-20 Terminal 54 Low Voltage**

**Range:**

-10.0 – par. 6-21 \*0.07V

**Function:**

Enter the low voltage value. This analog input scaling value should correspond to the minimum reference value, set in par. 3-02. See also the section *Reference Handling*.

**6-21 Terminal 54 High Voltage**

**Range:**

Par. 6-20 to 10.0 V \* 10.0V

**Function:**

Enter the high voltage value. This analog input scaling value should correspond to the maximum reference value, set in par. 3-03.

**6-22 Terminal 54 Low Current**

**Range:**

0.0 to par. 6-23 mA \*0.14mA

**Function:**

Enter the low current value. This reference signal should correspond to the minimum reference value, set in par. 3-02. The value must be set at >2 mA in order to activate the Live Zero Time-out Function in par. 6-01.

**6-23 Terminal 54 High Current**

**Range:**

Par. 6-22 to - 20.0 mA \*20.0 mA

**Function:**

Enter the value of the reference signal that corresponds to the maximum reference value, set in par. 3-03.

**6-24 Terminal 54 Low Ref./Feedb. Value**

**Range:**

-1000000.000 to par. 6-25 \* 0.000 Unit

**Function:**

Enter the analog input scaling value that corresponds to the minimum reference feedback value set in par. 3-02.

\* default setting ( ) display text [ ] value for use in communication via serial communication port



— How to Programme —

**6-25 Terminal 54 high ref./feedb. value**

**Range:**

Par. 6-24 to 1000000.000 \*1500.000 Unit

**Function:**

Enter the analog input scaling value that corresponds to the maximum reference feedback value set in par. 3-03.

**6-26 Terminal 54 Filter Time Constant**

**Range:**

0.001 - 10.000 s \* 0.001s

**Function:**

Enter the time constant. This is a first-order digital low pass filter time constant for suppressing electrical noise in terminal 54. A high time constant value improves dampening but also increases the time delay through the filter. This parameter cannot be adjusted while the motor is running.

□ **6-3\* Analog Input 3 (MCB 101)**

Parameter group for configuring the scale and limits for analog input 3 (X30/11) placed on option module MCB 101.

**6-30 Term. X30/11 Low Voltage**

**Range:**

-10 - par. 6-31 \* 0.07V

**Function:**

Sets the analog input scaling value to correspond to the minimum reference value (set in par. 3-02).

**6-31 Term. X30/11 High Voltage**

**Range:**

Par. 6-31 to 10.0 V \*10.0V

**Function:**

Sets the analog input scaling value to correspond to the maximum reference value (set in par. 3-03).

**6-34 Term. X30/11 Low Ref./Feedb. Value**

**Range:**

1000000.000 to par. 6-35 \*0.000 Unit

**Function:**

Sets the analog input scaling value to correspond to the minimum reference feedback value (set in par. 3-02).

**6-35 Term. X30/11 High Ref./Feedb. Value**

**Range:**

Par. 6-34 to 1000000.000 \*1500.000 Unit

**Function:**

Sets the analog input scaling value to correspond to the maximum reference feedback value (set in par. 3-03).

**6-36 Term. X30/11 Filter Time Constant**

**Range:**

0.001 - 10.000 s \*0.001s

**Function:**

A 1<sup>st</sup> order digital low pass filter time constant for suppressing electrical noise on terminal X30/11. Par. 6-36 cannot be changed while the motor is running.

□ **6-4\* Analog Input 4 (MCB 101)**

Parameter group for configuring the scale and limits for analog input 3 (X30/12) placed on option module MCB 101.

**6-40 Term. X30/12 Low Voltage**

**Range:**

-10.0 to par. 6-41 \*0.7V

**Function:**

Sets the analog input scaling value to correspond to the minimum reference value (set in par. 3-02).

**6-41 Term. X30/12 High Voltage**

**Range:**

Par. 6-41 to 10.0 V \*10.0V

**Function:**

Sets the analog input scaling value to correspond to the maximum reference value (set in par. 3-03).

**6-44 Term. X30/12 Low Ref./Feedb. Value**

**Range:**

-1000000.000 to par. 6-45 \*0.000 Unit

**Function:**

Sets the analog input scaling value to correspond to the minimum reference feedback value (set in par. 3-02).

**6-45 Term. X30/12 High Ref./Feedb. Value**

**Range:**

Par. 6-44 to 1000000.000 \*1500.000 Unit

\* default setting ( ) display text [ ] value for use in communication via serial communication port

— How to Programme —

**Function:**

Sets the analog input scaling value to correspond to the maximum reference feedback value (set in par. 3-03).

**6-46 Term. X30/12 Filter Time Constant**

**Range:**

0.001 - 10.000 s \*0.001s

**Function:**

A 1<sup>st</sup> order digital low pass filter time constant for suppressing electrical noise on terminal X30/12. Par. 6-46 cannot be changed while the motor is running.

□ **6-5\* Analog Output 1 (MCB 101)**

Parameters for configuring the scaling and limits for analog output 1, i.e. Terminal 42. Analog outputs are current outputs: 0/4 – 20 mA. Common terminal (terminal 39) is the same terminal and has the same electrical potential for analog common and digital common connection. Resolution on analog output is 12 bit.

**6-50 Terminal 42 Output**

**Option:**

No operation	[0]
Output frequency	[100]
Reference	[101]
Feedback	[102]
Motor current	[103]
Torque rel to lim	[104]
Torque rel to rated	[105]
Power	[106]
Speed	[107]
Torque	[108]
Output freq. 4-20mA	[130]
Reference 4-20mA	[131]
Feedback 4-20mA	[132]
Motor cur. 4-20mA	[133]
Torque % lim. 4-20mA	[134]
Torque % nom 4-20mA	[135]
Power 4-20mA	[136]
Speed 4-20mA	[137]
Torque 4-20mA	[138]
Bus ctrl. 0-20 mA	[139]
Bus ctrl. 4-20 mA	[140]
Bus ctrl. 0-20 mA, timeout	[141]
Bus ctrl. 4-20 mA, timeout	[142]

**Function:**

Select the function of Terminal 42 as an analog current output.

**6-51 Terminal 42 Output Min Scale**

**Range:**

0.00 – 200% \*0%

**Function:**

Scale the minimum output of the selected analog signal at terminal 42, as a percentage of the maximum signal value. E.g. if 0 mA (or 0 Hz) is desired at 25% of the maximum output value, then programme 25%. Scaling values up to 100% can never be higher than the corresponding setting in par. 6-52.

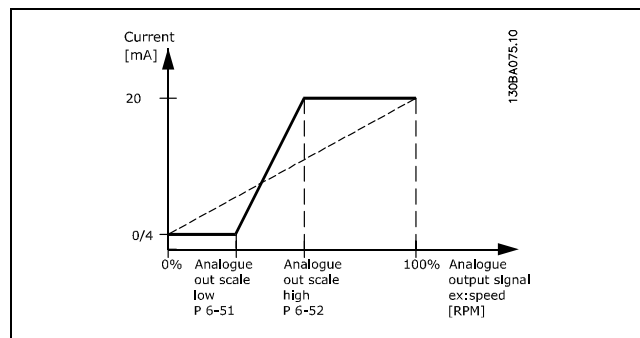

**6-52 Terminal 42 Output Max Scale**

**Range:**

000 – 200% \*100%

**Function:**

Scale the maximum output of the selected analog signal at terminal 42. Set the value to the maximum value of the current signal output. Scale the output to give a current lower than 20 mA at full scale; or 20 mA at an output below 100% of the maximum signal value. If 20 mA is the desired output current at a value between 0 - 100% of the full-scale output, programme the percentage value in the parameter, i.e. 50% = 20 mA. If a current between 4 and 20 mA is desired at maximum output (100%), calculate the percentage value as follows:

$$20 \text{ mA} / \text{desired maximum current} * 100\%$$

$$\text{i.e. } 10 \text{ mA} = \frac{20}{10} * 100 = 200\%$$

\* default setting ( ) display text [ ] value for use in communication via serial communication port

— How to Programme —

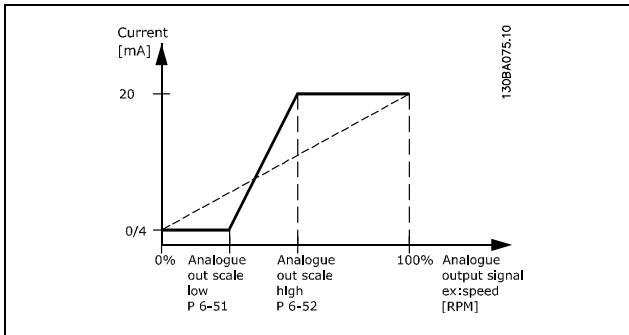

**6-53 Terminal 42 Output Bus Control**

**Range:**  
0.00 – 100.00 % \*0.00%

**Function:**  
Holds the level of Output 42 if controlled by bus.

**6-54 Terminal 42 Output Timeout Preset**

**Range:**  
0.00 – 100.00 % \*0.00%

**Function:**  
Holds the preset level of Output 42. In case of a bus timeout and a timeout function is selected in par. 6-50 the output will preset to this level.

- **6-6\* Analog Output 2 (MCB 101)**  
Analog outputs are current outputs: 0/4 - 20 mA. Common terminal (terminal X30/7) is the same terminal and electrical potential for analog common connection. Resolution on analog output is 12 bit.

**6-60 Terminal X30/7 Output**

**Option:**

No operation	[0]
MCO 0-20 mA	[52]
MCO 4-20 mA	[53]
Output frequency (0 . 1000 Hz), 0.20 mA	[100]
Output frequency (0 . 1000 Hz), 4.20 mA	
Reference (Refmin-max),0.20mA	[101]
Reference (Ref min-max), 4.20 mA	
Feedback (FB min-max)0.20mA	[102]
Feedback (FB min-max) 4.20 mA	
Motor current (0-Imax) 0.20mA	[103]
Motor current (0-Imax) 4.20 mA	
Torque relative to limit0-Tlim,0.20mA	[104]
Torque relative to limit 0-Tlim, 4.20 mA	
Torque relativetorated0-Tnom,0.20 mA	[105]
Torque relative to rated 0-Tnom, 4.20 mA	
Power (0-Pnom),0.20mA	[106]
Power (0-Pnom), 4.20 mA	
Speed (0-Speedmax), 0.20 mA	[107]

Speed (0-Speedmax), 4.20 mA	
Torque (+/-160% torque), 0-20mA	[108]
Torque (+/-160% torque), 4-20 mA	
Output freq. 4-20 mA	[130]
Reference 4-20 mA	[131]
Feedback 4-20 mA	[132]
Motor cur. 4-20 mA	[133]
Torque % lim. 4-20 mA	[134]
Torque % nom 4-20 mA	[135]
Power 4-20 mA	[136]
Speed 4-20 mA	[137]
Torque 4-20 mA	[138]
Bus Ctrl 0-20 mA	[139]
Bus Ctrl 4-20 mA	[140]
Bus Ctrl 0-20 mA, Timeout	[141]
Bus Ctrl 4-20 mA, Timeout	[142]

**6-61 Term. X30/8 Output Min Scale**

**Range:**  
0.00 - 200 % \*0%

**Function:**  
Scales the minimum output of the selected analog signal on terminal X30/8. Scale the minimum value as a percentage of the maximum signal value, i.e. 0 mA (or 0 Hz) is desired at 25% of the maximum output value and 25% is programmed. The value can never be higher than the corresponding setting in par. 6-62 if value is below 100%. This parameter is active when option module MCB 101 is mounted in the frequency converter.

**6-62 Term. X30/8 Output Max Scale**

**Range:**  
0.00 - 200 % \*100%

**Function:**  
Scales the maximum output of the selected analog signal on terminal X30/8. Scale the value to the desired maximum value of the current signal output. Scale the output to give a lower current than 20 mA at full scale or 20 mA at an output below 100% of the maximum signal value. If 20 mA is the desired output current at a value between 0 - 100% of the full-scale output, program the percentage value in the parameter, i.e. 50% = 20 mA. If a current between 4 and 20 MA is desired at maximum output (100%), calculate the percentage value as follows:

$$20 \text{ mA} / \text{desired maximum current} * 100\%$$

$$\text{i.e. } 10 \text{ mA} = \frac{20}{10} * 100 = 200\%$$

\* default setting ( ) display text [ ] value for use in communication via serial communication port

□ **Parameters: Controllers**

□ **7-\*\* Controllers**

Parameter group for configuring application controls.

□ **7-0\* Speed PID Ctrl.**

Parameters for configuring the speed PID control.

**7-00 Speed PID Feedback Source**

**Option:**

* Motor feedb. p.1-02 (FC 302 only)	[0]
24V encoder	[1]
MCB 102	[2]
MCO 305	[3]

**Function:**

Select the encoder for closed loop feedback. The feedback may come from a different encoder (typically mounted on the application itself) than the motor mounted encoder feedback selected in par. 1-02. This parameter cannot be adjusted while the motor is running.



**NB!:**

If separate encoders are used (FC 302 only) to ramp settings parameters in the following groups: 3-4\*, 3-5\*, 3-6\*, 3-7\* and 3-8\* must be adjusted according to the gear ratio between the two encoders.

**7-02 Speed PID ProportionalGain**

**Range:**

0.000 - 1.000 \* 0.015

**Function:**

Enter the speed controller proportional gain. The proportional gain amplifies the error (i.e. the deviation between the feedback signal and the set-point). This parameter is used with par. 1-00 *Speed open loop* [0] and *Speed closed loop* [1] control. Quick control is obtained at high amplification. However if the amplification is too great, the process may become unstable.

**7-03 Speed PID Integral Time**

**Range:**

2.0 - 20000.0 ms \* 8.0ms

**Function:**

Enter the speed controller integral time, which determines the time the internal PID control takes to correct errors. The greater the error, the more quickly the gain increases. The integral time causes a delay of the signal and therefore a dampening

effect, and can be used to eliminate steady state speed error. Obtain quick control through a short integral time, though if the integral time is too short, the process becomes unstable. An excessively long integral time disables the integral action, leading to major deviations from the required reference, since the process regulator takes too long to regulate errors. This parameter is used with *Speed open loop* [0] and *Speed closed loop* [1] control, set in par. 1-00 *Configuration Mode*.

**7-04 Speed PID Differentiation Time**

**Range:**

0.0 - 200.0 ms \* 30.0ms

**Function:**

Enter the speed controller differentiation time. The differentiator does not react to constant error. It provides gain proportional to the rate of change of the speed feedback. The quicker the error changes, the stronger the gain from the differentiator. The gain is proportional with the speed at which errors change. Setting this parameter to zero disables the differentiator. This parameter is used with par. 1-00 *Speed closed loop* [1] control.

**7-05 Speed PID Diff Gain Limit**

**Range:**

1.000 - 20.000 \* 5.000

**Function:**

Set a limit for the gain provided by the differentiator. Since the differential gain increases at higher frequencies, limiting the gain may be useful. For example, set up a pure D-link at low frequencies and a constant D-link at higher frequencies. This parameter is used with par. 1-00 *Speed closed loop* [1] control.

**7-06 Speed PID Lowpass Filter Time**

**Range:**

1.0 - 100.0 ms \* 10.0ms

**Function:**

Set a time constant for the speed control low-pass filter. The low-pass filter improves steady-state performance and dampens oscillations on the feedback signal. This is an advantage if there is a great amount on noise in the system, see illustration below. For example, if a time constant ( $\tau$ ) of 100 ms is programmed, the cut-off frequency for the low-pass filter will be  $1/0.1 = 10 \text{ RAD/sec.}$ , corresponding to  $(10/2 \times \pi) = 1.6 \text{ Hz.}$  The PID regulator only regulates a feedback signal that

\* default setting ( ) display text [ ] value for use in communication via serial communication port

— How to Programme —

varies by a frequency of less than 1.6 Hz. If the feedback signal varies by a higher frequency than 1.6 Hz, the PID regulator does not react.

Note that severe filtering can be detrimental to dynamic performance.

This parameter is used with par. 1-00 *Speed closed loop* [1] and *Torque* [2] control.

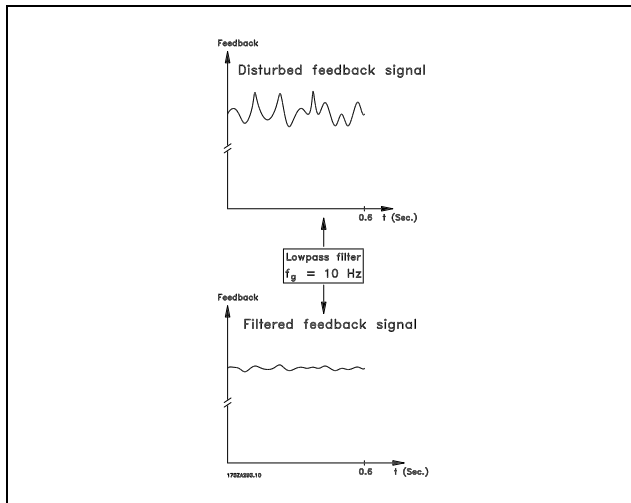

□ **7-2\* Process Ctrl. Feedb.**

Select the feedback sources for the Process PID Control, and how this feedback should be handled.

**7-20 Process CL Feedback 1 Resource**

**Option:**

- \*No function [0]
- Analog input 53 [1]
- Analog input 54 [2]
- Frequency input 29 (FC 302 only) [3]
- Frequency input 33 [4]
- Bus feedback 1 [5]
- Bus feedback 2 [6]
- Analog input X30/11 [7]
- Analog input X30/12 [8]

**Function:**

The effective feedback signal is made up of the sum of up to two different input signals. Select which frequency converter input should be treated as the source of the first of these signals. The second input signal is defined in par. 7-22.

**7-22 Process CL Feedback 2 Resource**

**Option:**

- \*No function [0]
- Analog input 53 [1]
- Analog input 54 [2]
- Frequency input 29 (FC 302 only) [3]

\* default setting ( ) display text [ ] value for use in communication via serial communication port

- Frequency input 33 [4]
- Bus feedback 1 [5]
- Bus feedback 2 [6]
- Analog input X30/11 [7]
- Analog input X30/12 [8]

**Function:**

The effective feedback signal is made up of the sum of up to two different input signals. Select which frequency converter input should be treated as the source of the second of these signals. The first input signal is defined in par. 7-21.

□ **7-3\* Process PID Ctrl.**

Parameters for configuring the Process PID control.

**7-30 Process PID Normal/ Inverse Control**

**Option:**

- \*Normal [0]
- Inverse [1]

**Function:**

Select *Normal* [0] to set the process control to increase the output frequency. Select *Inverse* [1] to set the process control to reduce the output frequency. Normal and inverse control are implemented by introducing a difference between the reference signal and the feedback signal.

**7-31 Process PID Anti Windup**

**Option:**

- \*Off [0]
- On [1]

**Function:**

Select *Off* [0] to cease regulation of an error when the output frequency can no longer be adjusted. Select *On* [1] to continue regulation of an error even when the output frequency cannot be increased or decreased.

**7-32 Process PID Start Speed**

**Range:**

0 - 6000 RPM \*ORPM

**Function:**

Enter the motor speed to be attained as a start signal for commencement of PID control. When the power is switched on, the frequency converter will commence ramping and then operate under speed open loop control. Thereafter, when the Process PID start speed is reached, the frequency converter will change over to Process PID control.

## — How to Programme —

**7-33 Process PID Proportional Gain****Range:**

0.00 - 10.00 N/A \*0.01N/A

**Function:**

Enter the PID proportional gain. The proportional gain multiplies the error between the set point and the feedback signal.

**7-34 Process PID Integral Time****Range:**

0.01 - 10000.00 \*10000.00s

**Function:**

Enter the PID integral time. The integrator provides an increasing gain at a constant error between the set point and the feedback signal. The integral time is the time needed by the integrator to reach the same gain as the proportional gain.

**7-35 Process PID Differentiation Time****Range:**

0.00 - 10.00 s \*0.00s

**Function:**

Enter the PID differentiation time. The differentiator does not react to a constant error, but provides a gain only when the error changes. The shorter the PID differentiation time, the stronger the gain from the differentiator.

**7-36 Process PID Diff. Gain Limit****Range:**

1.0 - 50.0 N/A \*5.0N/A

**Function:**

Enter a limit for the differentiator gain (DG). If there is no limit, the DG will increase when there are fast changes. Limit the DG to obtain a pure differentiator gain at slow changes and a constant differentiator gain where fast changes occur.

**7-38 Process PID Feed Forward Factor****Range:**

0 - 500% \*0%

**Function:**

Enter the PID feed forward (FF) factor. The FF factor sends a constant fraction of the reference signal to bypass the PID control, so the PID control only affects the remaining fraction of the control signal. Any change to this parameter will thus affect the motor speed. When the FF factor is activated it provides less overshoot, and high dynamics when

changing the set point. Par. 7-38 is active when par. 1-00 *Configuration Mode* is set to [3] Process.

**7-39 On Reference Bandwidth****Range:**

0 - 200% \*5%

**Function:**

Enter the On Reference bandwidth. When the PID Control Error (the difference between the reference and the feedback) is less than the set value of this parameter the On Reference status bit is high, i.e. =1.

## □ Parameters: Communications and Options

### □ 8-\*\* Comm. and Options

Parameter group for configuring communications and options.

### □ 8-0\* General Settings

General settings for communications and options.

#### 8-01 Control Site

##### Option:

*Digital and ctrl. word	[0]
Digital only	[1]
Control word only	[2]

##### Function:

Select *Digital and ctrl. word* [0] for control using both digital input and control word.

Select *Digital only* [1] for control using digital inputs only.

Select *Control word only* [2] for control using control word only.

The setting in this parameter overrules the settings in par. 8-50 to 8-56.

#### 8-02 Control Word Source

##### Option:

None	[0]
FC RS485	[1]
FC USB	[2]
Option A	[3]
Option B	[4]
Option C0	[5]
Option C1	[6]

##### Function:

Select the source of the control word: one of two serial interfaces or four installed options. During initial power-up, the frequency converter automatically sets this parameter to *Option A* [3] if it detects a valid fieldbus option installed in slot A. If the option is removed, the frequency converter detects a change in the configuration, sets par. 8-02 back to default setting *FC RS485*, and the frequency converter then trips. If an option is installed after initial power-up, the setting of par. 8-02 will not change but the drive will trip and display: *Alarm 67 Option Changed*. This parameter cannot be adjusted while the motor is running.

#### 8-03 Control Word Timeout Time

##### Range:

0.1 - 18000.0 s \*1.0s

##### Function:

Enter the maximum time expected to pass between the reception of two consecutive telegrams. If this time is exceeded, it indicates that the serial communication has stopped. The function selected in par. 8-04 *Control Word Time-out Function* will then be carried out. The time-out counter is triggered by a valid control word. Acyclic DP V1 does not trigger the time-out counter.

#### 8-04 Control Word Timeout Function

##### Option:

*Off	[0]
Freeze Output	[1]
Stop	[2]
Jogging	[3]
Max. Speed	[4]
Stop and trip	[5]
Select set-up 1	[7]
Select set-up 2	[8]
Select set-up 3	[9]
Select set-up 4	[10]

##### Function:

Select the time-out function. The time-out function activates when the control word fails to be updated within the time period specified in par. 8-03 *Control Word Time-out Time*.

- *Off* [0]: Resume control via serial bus (Fieldbus or standard) using the most recent control word.
- *Freeze output* [1]: Freeze output frequency until communication resumes.
- *Stop* [2]: Stop with auto restart when communication resumes.
- *Jogging* [3]: Run the motor at JOG frequency until communication resumes.
- *Max. freq.* [4]: Run the motor at maximum frequency until communication resumes.
- *Stop and trip* [5]: Stop the motor, then reset the frequency converter in order to restart: via the fieldbus, via the reset button on the LCP or via a digital input.
- *Select set-up 1-4* [7] - [10]: This option changes the set-up upon reestablishment of communication following a control word time-out. If communication resumes causing the time-out situation to disappear, par. 8-05 *End-of-time-out Function* defines whether to resume the set-up used before the time-out or

\* default setting ( ) display text [ ] value for use in communication via serial communication port

— How to Programme —

to retain the set-up endorsed by the time-out function. Note the following configuration required in order to change the set-up after a time-out: Set Par. 0-10 *Active set-up to Multi set-up* [9], and select the relevant link in par. 0-12 *This Set-up Linked To*.

**8-05 End-of-Timeout Function**

**Option:**

- \*Hold set-up [0]
- Resume set-up [1]

**Function:**

Select the action after receiving a valid control word following a time-out. This parameter is active only when par. 8-04 is set to *Set-up 1-4*. *Hold*: The frequency converter retains the set-up selected in par. 8-04 and displays a warning, until par. 8-06 toggles. Then the frequency converter resumes its original set-up. *Resume*: The frequency converter resumes the set-up active prior to the time-out.

**8-06 Reset Control Word Timeout**

**Option:**

- \*Do not reset [0]
- Do reset [1]

**Function:**

Select *Do reset* [1] to return the frequency converter to the original set-up following a control word time-out. When the value is set to *Do reset* [1], the frequency converter performs the reset and then immediately reverts to the *Do not reset* [0] setting. Select *Do not reset* [0] to retain the set-up specified in par. 8-04, *Select setup 1-4* following a control word time-out. This parameter is active only when *Hold set-up* [0] has been selected in par. 8-05 *End-of-Time-out Function*.

**8-07 Diagnosis Trigger**

**Option:**

- \*Disable [0]
- Trigger on alarms [1]
- Trigger alarms/warn. [2]

**Function:**

This parameter enables and controls the drive diagnosis function and permits expansion of the diagnosis data to 24 byte. It relates only to Profibus.

- *Disable* [0]: Do not send extended diagnosis data even if they appear in the frequency converter.

- *Trigger on alarms* [1]: Send extended diagnosis data when one or more alarms appear in alarm par. 16-90 or 9-53.
- *Trigger alarms/warn.* [2]: Send extended diagnosis data if one or more alarms or warnings appear in alarm par. 16-90, 9-53, or warning par. 16-92.

The content of the extended diagnosis frame is as follows:

Byte	Content	Description
0 - 5	Standard DP Diagnose Data	Standard DP Diagnose Data
6	PDU length xx	Header of extended diagnostic data
7	Status type = 0x81	Header of extended diagnostic data
8	Slot = 0	Header of extended diagnostic data
9	Status info = 0	Header of extended diagnostic data
10 - 13	VLT par. 16-92	VLT warning word
14 - 17	VLT par. 16-03	VLT status word
18 - 21	VLT par. 16-90	VLT alarm word
22 - 23	VLT par. 9-53	Communication warning word (Profibus)

Enabling diagnosis may cause increased bus traffic. Diagnosis functions are not supported by all fieldbus types.

- **8-1\* Ctrl. Word Settings**  
Parameters for configuring the option control word profile.

**8-10 Control Word Profile**

**Option:**

- \*FC profile [0]
- PROFIdrive profile [1]
- ODVA [5]
- CANopen DSP 402 [7]

**Function:**

Select the interpretation of the control and status words corresponding to the installed fieldbus. Only the selections valid for the fieldbus installed in slot A will be visible in the LCP display. For guidelines in selection of *FC profile* [0] and *PROFIdrive profile* [1] please refer to the *Serial communication via RS 485 Interface* section in the *How to Programme* chapter.

\* default setting ( ) display text [ ] value for use in communication via serial communication port



— How to Programme —

For additional guidelines in the selection of *PROFIdrive profile* [1], *ODVA* [5] and *CANopen DSP 402* [7], please refer to the Operating Instructions for the installed fieldbus.

**8-13 Configurable Status Word STW**

**Option:**

Bit 12	[12]
Bit 13	[13]
Bit 14	[14]
Bit 15	[15]

**Function:**

This parameter enables configuration of bit 12 – 15 in the status word.

**Profile Default [1]:** The function on the bit corresponds to the profile default selected in par. 8-10.

**Alarm 68 Only [2]:** The bit is only set in case of an Alarm 68.

**Trip except Alarm 68 [3]:** The bit is set in case of a trip, except if the trip is executed by an Alarm 68.

**T37 DI status [16]:** The bit indicates the status of terminal 37.

"0" indicates T37 is low (safe stop)

"1" indicates T37 is high (normal)

□ **8-3\* FC Port Settings**

Parameters for configuring the FC Port.

**8-30 Protocol**

**Option:**

*FC	[0]
FC MC	[1]

**Function:**

Select the protocol for the FC (standard) port.

**8-31 Address**

**Range:**

1 - 126 \*1

**Function:**

Enter the address for the FC (standard) port.  
Valid range: 1 - 126.

**8-32 FC Port Baud Rate**

**Option:**

2400 Baud	[0]
4800 Baud	[1]
*9600 Baud	[2]
19200 Baud	[3]
38400 Baud	[4]
115200 Baud	[7]

**Function:**

Baud rate selection for the FC (standard) port.

**8-35 Minimum Response Delay**

**Range:**

1 - 500 ms \*10ms

**Function:**

Specify the minimum delay time between receiving a request and transmitting a response. This is used for overcoming modem turnaround delays.

**8-36 Max Response Delay**

**Range:**

1 - 10000 ms \*5000ms

**Function:**

Specify the maximum permissible delay time between transmitting a request and receiving a response. Exceeding this delay time will cause control word time-out.

**8-37 Max Inter-Char Delay**

**Range:**

0 - 30 ms \*25ms

**Function:**

Specify the maximum permissible time interval between receipt of two bytes. This parameter activates time-out if transmission is interrupted. This parameter is active only when par. 8-30 is set to *FC MC* [1] protocol.

□ **8-5\* Digital/Bus**

Parameters for configuring the control word Digital/Bus merging.

**8-50 Coasting Select**

**Option:**

Digital input	[0]
Bus	[1]
Logic AND	[2]
*Logic OR	[3]

**Function:**

Select control of the coasting function via the terminals (digital input) and/or via the bus.



**NB!:**

This parameter is active only when par. 8-01 *Control Site* is set to [0] *Digital and control word*.

\* default setting ( ) display text [ ] value for use in communication via serial communication port

— How to Programme —

**8-51 Quick Stop Select**

**Option:**

Digital input	[0]
Bus	[1]
Logic AND	[2]
*Logic OR	[3]

**Function:**

Select control of the Quick Stop function via the terminals (digital input) and/or via the bus.



**NB!:**  
This parameter is active only when par. 8-01 *Control Site* is set to [0] *Digital and control word*.

**8-52 DC Brake Select**

**Option:**

Digital input	[0]
Bus	[1]
Logic AND	[2]
*Logic OR	[3]

**Function:**

Select control of the DC brake via the terminals (digital input) and/or via the fieldbus.



**NB!:**  
This parameter is active only when par. 8-01 *Control Site* is set to [0] *Digital and control word*.

**8-53 Start Select**

**Option:**

Digital input	[0]
Bus	[1]
Logic AND	[2]
*Logic OR	[3]

**Function:**

Select control of the frequency converter start function via the terminals (digital input) and/or via the fieldbus.  
Select *Bus* [1], to activate the Start command via the serial communication port or fieldbus option.  
Select *Logic AND* [2] to activate the Start command via the fieldbus/serial communication port, AND additionally via one of the digital inputs.  
Select *Logic OR* [3] to activate the Start command via the fieldbus/serial communication port OR via one of the digital inputs.



**NB!:**  
This parameter is active only when par. 8-01 *Control Site* is set to [0] *Digital and control word*.

**8-54 Reversing Select**

**Option:**

Digital input	[0]
Bus	[1]
Logic AND	[2]
*Logic OR	[3]

**Function:**

Select control of the frequency converter reverse function via the terminals (digital input) and/or via the fieldbus.  
Select *Bus* [1], to activate the Reverse command via the serial communication port or fieldbus option.  
Select *Logic AND* [2] to activate the Reverse command via the fieldbus/serial communication port, AND additionally via one of the digital inputs.  
Select *Logic OR* [3] to activate the Reverse command via the fieldbus/serial communication port OR via one of the digital inputs.



**NB!:**  
This parameter is active only when par. 8-01 *Control Site* is set to [0] *Digital and control word*.

**8-55 Set-up Select**

**Option:**

Digital input	[0]
Bus	[1]
Logic AND	[2]
*Logic OR	[3]

**Function:**

Select control of the frequency converter set-up selection via the terminals (digital input) and/or via the fieldbus.  
Select *Bus* [1], to activate the set-up selection via the serial communication port or fieldbus option.  
Select *Logic AND* [2] to activate the set-up selection via the fieldbus/serial communication port, AND additionally via one of the digital inputs.  
Select *Logic OR* [3] to activate the set-up selection via the fieldbus/serial communication port OR via one of the digital inputs.



**NB!:**  
This parameter is active only when par. 8-01 *Control Site* is set to [0] *Digital and control word*.

\* default setting ( ) display text [ ] value for use in communication via serial communication port

### 8-56 Preset Reference Select

#### Option:

Digital input	[0]
Bus	[1]
Logic AND	[2]
*Logic OR	[3]

#### Function:

Select control of the frequency converter Preset Reference selection via the terminals (digital input) and/or via the fieldbus.

Select *Bus* [1], to activate the Preset Reference selection via the serial communication port or fieldbus option.

Select *Logic AND* [2] to activate the Preset Reference selection via the fieldbus/serial communication port, AND additionally via one of the digital inputs.

Select *Logic OR* [3] to activate the Preset Reference selection via the fieldbus/serial communication port OR via one of the digital inputs.



#### NB!:

This parameter is active only when par. 8-01 *Control Site* is set to [0] *Digital and control word*.

### □ 8-9\* Bus Jog

Parameters for configuring the Bus Jog.

#### 8-90 Bus Jog 1 Speed

##### Range:

0 - par. 4-13 RPM \*100RPM

##### Function:

Enter the jog speed. This is a fixed jog speed activated via the serial port or fieldbus option.

#### 8-91 Bus Jog 2 Speed

##### Range:

0 - par. 4-13 RPM \*200RPM

##### Function:

Enter the jog speed. This is a fixed jog speed activated via the serial port or fieldbus option.

## □ Parameters: Profibus

### □ 9-\*\* Profibus

Parameter group for all Profibus-specific parameters.

#### 9-15 PCD Write Configuration

Array [10]

#### Option:

None

3-02 Minimum Reference  
 3-03 Maximum Reference  
 3-12 Catch Up/Slow Down Value  
 3-41 Ramp 1 Ramp Up Time  
 3-42 Ramp 1 Ramp Down Time  
 3-51 Ramp 2 Ramp Up Time  
 3-52 Ramp 2 Ramp Down Time  
 3-80 Jog Ramp Time  
 3-81 Quick Stop Ramp Time  
 4-11 Motor Speed Low Limit [RPM]  
 4-13 Motor Speed High Limit [RPM]  
 4-16 Torque Limit Motor Mode  
 4-17 Torque Limit Generator Mode  
 7-28 Minimum Feedback  
 7-29 Maximum Feedback  
 8-90 Bus Jog 1 Speed  
 8-91 Bus Jog 2 Speed  
 16-80 Fieldbus CTW 1  
 16-82 Fieldbus REF 1  
 34-01 PCD 1 Write to MCO  
 34-02 PCD 2 Write to MCO  
 34-03 PCD 3 Write to MCO  
 34-04 PCD 4 Write to MCO  
 34-05 PCD 5 Write to MCO  
 34-06 PCD 6 Write to MCO  
 34-07 PCD 7 Write to MCO  
 34-08 PCD 8 Write to MCO  
 34-09 PCD 9 Write to MCO  
 34-10 PCD 10 Write to MCO

#### Function:

Select the parameters to be assigned to PCD 3 to 10 of the telegrams. The number of available PCDs depends on the telegram type. The values in PCD 3 to 10 will then be written to the selected parameters as data values. Alternatively, specify a standard Profibus telegram in par. 9-22.

#### 9-16 PCD Read Configuration

Array [10]

#### Option:

None

\* default setting ( ) display text [ ] value for use in communication via serial communication port

16-00 Control Word  
 16-01 Reference [Unit]  
 16-02 Reference %  
 16-03 Status Word  
 16-04 Main Actual Value [Unit]  
 16-05 Main Actual Value [%]  
 16-09 Custom Readout  
 16-10 Power [kW]  
 16-11 Power [hp]  
 16-12 Motor Voltage  
 16-13 Frequency  
 16-14 Motor Current  
 16-16 Torque  
 16-17 Speed [RPM]  
 16-18 Motor Thermal  
 16-19 KTY Sensor Temperature  
 16-21 Phase Angle  
 16-30 DC Link Voltage  
 16-32 Brake Energy / s  
 16-33 Brake Energy / 2 min  
 16-34 Heatsink Temp.  
 16-35 Inverter Thermal  
 16-38 SL Control State  
 16-39 Control Card Temp.  
 16-50 External Reference  
 16-51 Pulse Reference  
 16-52 Feedback [Unit]  
 16-53 Digi Pot Reference  
 16-60 Digital Input  
 16-61 Terminal 53 Switch Setting  
 16-62 Analog Input 53  
 16-63 Terminal 54 Switch Setting  
 16-64 Analog Input 54  
 16-65 Analog Output 42 [mA]  
 16-66 Digital Output [bin]  
 16-67 Freq. Input #29 [Hz]  
 16-68 Freq. Input #33 [Hz]  
 16-69 Pulse Output #27 [Hz]  
 16-70 Pulse Output #29 [Hz]  
 16-71 Pulse Output [bin]  
 16-84 Comm Option STW [Binary]  
 16-85 FC port CTW 1 Signal  
 16-90 Alarm Word  
 16-91 Alarm Word 2  
 16-92 Warning Word  
 16-93 Warning Word 2  
 16-94 Extended Status Word  
 16-95 Extended Status Word 2  
 34-21 PCD 1 Read from MCO  
 34-22 PCD 2 Read from MCO  
 34-23 PCD 3 Read from MCO  
 34-24 PCD 4 Read from MCO  
 34-25 PCD 5 Read from MCO  
 34-26 PCD 6 Read from MCO

— How to Programme —

- 34-27 PCD 7 Read from MCO
- 34-28 PCD 8 Read from MCO
- 34-29 PCD 9 Read from MCO
- 34-30 PCD 10 Read from MCO
- 34-40 Digital Inputs
- 34-41 Digital Outputs
- 34-50 Actual Position
- 34-51 Commanded Position
- 34-52 Actual Master Position
- 34-53 Slave Index Position
- 34-54 Master Index Position
- 34-55 Curve Position
- 34-56 Track Error
- 34-57 Synchronizing Error
- 34-58 Actual Velocity
- 34-59 Actual Master Velocity
- 34-60 Synchronizin Status
- 34-61 Axis Status
- 34-62 Program Status

**Function:**

Select the parameters to be assigned to PCD 3 to 10 of the telegrams. The number of available PCDs depends on the telegram type. PCDs 3 to 10 contain the actual data values of the selected parameters. For standard Profibus telegrams, see par. 9-22.

**9-18 Node Address**

**Range:**

0 - 126 \*126

**Function:**

Enter the station address in this parameter or alternatively in the hardware switch. In order to adjust the station address in par. 9-18, the hardware switch must be set to 126 or 127 (i.e. all switches set to 'on'). Otherwise this parameter will display the actual setting of the switch.

**9-22 Telegram Selection**

**Option:**

Standard telegram 1	[1]
PPO 1	[101]
PPO 2	[102]
PPO 3	[103]
PPO 4	[104]
PPO 5	[105]
PPO 6	[106]
PPO 7	[107]
*PPO 8	[108]

**Function:**

Select a standard Profibus telegram configuration for the frequency converter, as an alternative

to using the freely configurable telegrams in par. 9-15 and 9-16.

**9-23 Parameters for Signals**

Array [1000]

**Option:**

- None
- 3-02 Minimum Reference
- 3-03 Maximum Reference
- 3-12 Catch Up/Slow Down Value
- 3-41 Ramp 1 Ramp Up Time
- 3-42 Ramp 1 Ramp Down Time
- 3-51 Ramp 2 Ramp Up Time
- 3-52 Ramp 2 Ramp Down Time
- 3-80 Jog Ramp Time
- 3-81 Quick Stop Ramp Rime
- 4-11 Motor Speed Low Limit
- 4-13 Motor Speed High Limit
- 4-16 Torque Limit Motor Mode
- 4-17 Torque Limit Generator Mode
- 7-28 Minimum Feedback
- 7-29 Maximum Feedback
- 8-90 Bus Jog 1 Speed
- 8-91 Bus Jog 2 Speed
- 16-00 Control Word
- 16-01 Reference [Unit]
- 16-02 Reference %
- 16-03 Status Word
- 16-04 Main Actual Value [Unit]
- 16-05 Main Actual Value [%]
- 16-10 Power [kW]
- 16-11 Power [hp]
- 16-12 Motor Voltage
- 16-13 Frequency
- 16-14 Motor Current
- 16-16 Torque
- 16-17 Speed [RPM]
- 16-18 Motor Thermal
- 16-19 KTY Sensor Temperature
- 16-21 Phase Angle
- 16-30 DC Link Voltage
- 16-32 Brake Energy / s
- 16-33 Brake Energy / 2 Min
- 16-34 Heatsink Temp.
- 16-35 Inverter Thermal
- 16-38 SL Control State
- 16-39 Controlcard Temp.
- 16-50 External Reference
- 16-51 Pulse Reference
- 16-52 Feedback [Unit]
- 16-53 Digi Pot Reference

\* default setting ( ) display text [ ] value for use in communication via serial communication port

## — How to Programme —

16-60 Digital Input  
 16-61 Terminal 53 Switch Setting  
 16-62 Analog Input 53  
 16-63 Terminal 53 Switch Setting  
 16-64 Analog Input 54  
 16-65 Analog Output 42 [mA]  
 16-66 Digital Output [bin]  
 16-67 Freq. Input #29 [Hz]  
 16-68 Freq. Input #33 [Hz]  
 16-69 Pulse Output #27 [Hz]  
 16-70 Pulse Output #29 [Hz]  
 16-80 Fieldbus CTW 1  
 16-82 Fieldbus REF 1  
 16-84 Comm Option STW  
 16-85 FC Port CTW 1  
 16-90 Alarm Word  
 16-91 Alarm Word 2  
 16-92 Warning Word  
 16-93 Warning Word 2  
 16-94 Extended Status Word  
 16-95 Extended Status Word 2  
 34-01 PCD 1 Write to MCO  
 34-02 PCD 2 Write to MCO  
 34-03 PCD 3 Write to MCO  
 34-04 PCD 4 Write to MCO  
 34-05 PCD 5 Write to MCO  
 34-06 PCD 6 Write to MCO  
 34-07 PCD 7 Write to MCO  
 34-08 PCD 8 Write to MCO  
 34-09 PCD 9 Write to MCO  
 34-10 PCD 10 Write to MCO  
 34-21 PCD 1 Read from MCO  
 34-22 PCD 2 Read from MCO  
 34-23 PCD 3 Read from MCO  
 34-24 PCD 4 Read from MCO  
 34-25 PCD 5 Read from MCO  
 34-26 PCD 6 Read from MCO  
 34-27 PCD 7 Read from MCO  
 34-28 PCD 8 Read from MCO  
 34-29 PCD 9 Read from MCO  
 34-30 PCD 10 Read from MCO  
 34-40 Digital Inputs  
 34-41 Digital Outputs  
 34-50 Actual Position  
 34-51 Commanded Position  
 34-52 Actual Master Position  
 34-53 Slave Index Position  
 34-54 Master Index Position  
 34-55 Curve Position  
 34-56 Track Error  
 34-57 Synchronizing Error  
 34-58 Actual Velocity  
 34-59 Actual Master Velocity  
 34-60 Synchronizing Status

34-61 Axis Status  
 34-62 Program Status

**Function:**

This parameter contains a list of signals available for selection in par. 9-15 and 9-16.

**9-27 Parameter Edit****Option:**

Disabled	[0]
*Enabled	[1]

**Function:**

Parameters can be edited via Profibus, the standard RS485 interface, or the LCP. Select *Disabled* [0] to disable editing via Profibus.

**9-28 Process Control****Option:**

Disable	[0]
*Enable cyclic master	[1]

**Function:**

Process control (setting of Control Word, speed reference, and process data) is possible via either Profibus or standard fieldbus but not both simultaneously. Local control is always possible via the LCP. Control via process control is possible via either terminals or fieldbus depending on the settings in par. 8-50 to 8-56. Select *Disable* [0] to disable process control via Profibus, and enable process control via standard fieldbus or Profibus Master class 2. Select *Enable cyclic master* [1] to enable process control via Profibus Master Class 1, and disable process control via standard fieldbus or Profibus Master class 2.

\* default setting ( ) display text [ ] value for use in communication via serial communication port

— How to Programme —

**9-53 Profibus Warning Word**

**Option:**

Bit:	Meaning:
0	Connection with DP-master is not
1	Not used
2	FDL (Field-bus Data link Layer) is not ok
3	Clear data command received
4	Actual value is not updated
5	Baudrate search
6	PROFIBUS ASIC is not transmitting
7	Initializing of PROFIBUS is not ok
8	Drive is tripped
9	Internal CAN error
10	Wrong configuration data from PLC
11	Wrong ID sent by PLC
12	Internal error occurred
13	Not configured
14	Timeout active
15	Warning 34 active

**Function:**

This parameter displays Profibus communication warnings. Please refer to the Profibus Operating Instructions for further information.

**9-63 Actual Baud Rate**

**Option:**

Read only	
9.6 kbit/s	[0]
19.2 kbit/s	[1]
93.75 kbit/s	[2]
187.5 kbit/s	[3]
500 kbit/s	[4]
1500 kbit/s	[6]
3000 kbit/s	[7]
6000 kbit/s	[8]
12000 kbit/s	[9]
31.25 kbit/s	[10]
45.45 kbit/s	[11]
No baud rate found	[255]

**Function:**

This parameter displays the actual Profibus baud rate. The Profibus Master automatically sets the baud rate.

**9-65 Profile Number**

**Option:**

Read only	
0 - 0	* 0

**Function:**

This parameter contains the profile identification. Byte 1 contains the profile number and byte 2 the version number of the profile.



**NB!:**

This parameter is not visible via LCP.

**9-70 Edit Set-up**

**Option:**

Factory setup	[0]
*Setup 1	[1]
Setup 2	[2]
Setup 3	[3]
Setup 4	[4]
Active setup	[9]

**Function:**

Select the set-up to be edited. Select *Set-up 1-4* [1]-[4] to edit a specific set-up. Select *Active set-up* [9] to follow the active set-up selected in par. 0-10. Select *Factory set-up* [0] for default data. This option can be used as a data source to return the other set-ups to a known state. This parameter is unique to LCP and fieldbuses. See also par. 0-11 *Edit set-up*.

**9-71 Save Data Values**

**Option:**

*Off	[0]
Store edit setup	[1]
Store all set-ups	[2]

**Function:**

Parameter values changed via Profibus are not automatically stored in non-volatile memory. Use this parameter to activate a function that stores parameter values in the EEPROM non-volatile memory, so changed parameter values will be retained at power-down. Select *Off* [0] to deactivate the non-volatile storage function. Select *Store edit setup* [1] to store all parameter values in the set-up selected in par. 9-70 in the non-volatile memory. The selection returns to *Off* [0] when all values have been stored. Select *Store all set-ups* [2] to store all parameter values for all set-ups in the non-volatile memory. The selection returns to *Off* [0] when all parameter values have been stored.

— How to Programme —

**9-72 Drive Reset**

**Option:**

- \*No action [0]
- Power-on reset [1]
- Comm. option reset [3]

**Function:**

Select *Power-on reset* [1] to reset the frequency converter upon power-up, as for power-cycle. Select *Comm. option reset* [3] to reset the Profibus option only, useful after changing certain settings in parameter group 9-\*\*, e.g. par. 9-18. When reset, the frequency converter disappears from the fieldbus, which may cause a communication error from the master.

**9-80 Defined Parameters (1)**

Array [116]

**Option:**

- No LCP access
- Read only
- 0 - 115 \*0

**Function:**

This parameter displays a list of all the defined frequency converter parameters available for Profibus.

**9-81 Defined Parameters (2)**

Array [116]

**Option:**

- No LCP access
- Read only
- 0 - 115 \*0

**Function:**

This parameter displays a list of all the defined frequency converter parameters available for Profibus.

**9-82 Defined Parameters (3)**

Array [116]

**Option:**

- No LCP access
- Read only
- 0 - 115 \*0

**Function:**

This parameter displays a list of all the defined frequency converter parameters available for Profibus.

**9-83 Defined Parameters (4)**

Array [116]

**Option:**

- No LCP access
- Read only
- 0 - 115 \*0

**Function:**

This parameter displays a list of all the defined frequency converter parameters available for Profibus.

**9-90 Changed Parameters (1)**

Array [116]

**Option:**

- No LCP access
- Read only
- 0 - 115 \*0

**Function:**

This parameter displays a list of all the frequency converter parameters deviating from default setting.

**9-91 Changed Parameters (2)**

Array [116]

**Option:**

- No LCP access
- Read only
- 0 - 115 \*0

**Function:**

This parameter displays a list of all the frequency converter parameters deviating from default setting.

**9-92 Changed Parameters (3)**

Array [116]

**Option:**

- No LCP access
- Read only
- 0 - 115 \*0

\* default setting ( ) display text [ ] value for use in communication via serial communication port



## — How to Programme —

**Function:**

This parameter displays a list of all the frequency converter parameters deviating from default setting.

**9-93 Changed parameters (4)**

Array [116]

**Option:**

No LCP access

Read only

0 - 115

\*0

**Function:**

This parameter displays a list of all the frequency converter parameters deviating from default setting.

□ **Parameters: DeviceNet CAN Fieldbus**

□ **10-\*\* DeviceNet CAN Fieldbus**  
Parameter group for DeviceNet CAN fieldbus parameters.

□ **10-0\* Common Settings**  
Parameter group for configuring common settings for CAN fieldbus options.

**10-00 CAN Protocol**

**Option:**

CANopen	[0]
*DeviceNet	[1]

**Function:**

View the active CAN protocol.



**NB!:**  
The options depend on installed option.

**10-01 Baud Rate Select**

**Option:**

10 Kbps	[16]
20 Kbps	[17]
50 Kbps	[18]
100	[19]
*125 Kbps	[20]
250 Kbps	[21]
500 Kbps	[22]

**Function:**

Select the fieldbus transmission speed. The selection must correspond to the transmission speed of the master and the other fieldbus nodes.

**10-02 MAC ID**

**Option:**

0 - 127 N/A	*63 N/A
-------------	---------

**Function:**

Selection of station address. Every station connected to the same DeviceNet network must have an unambiguous address.

**10-05 Readout Transmit Error Counter**

**Range:**

0 - 255	*0
---------	----

**Function:**

View the number of CAN control transmission errors since the last power-up.

**10-06 Readout Receive Error Counter**

**Range:**

0 - 255	*0
---------	----

**Function:**

View the number of CAN control receipt errors since the last power-up.

**10-07 Readout Bus Off Counter**

**Range:**

0 - 255 N/A	*0N/A
-------------	-------

**Function:**

View the number of Bus Off events since the last power-up.

□ **10-1\* DeviceNet**  
Parameters specific to the DeviceNet fieldbus.

**10-10 Process Data Type Selection**

**Option:**

Instance 100/150	[0]
Instance 101/151	[1]
Instance 20/70	[2]
Instance 21/71	[3]

**Function:**

Select the Instance (telegram) for data transmission. The Instances available are dependent upon the setting of par. 8-10 *Control Word Profile*. When par. 8-10 is set to [0] *FC profile*, par. 10-10 options [0] and [1] are available. When par. 8-10 is set to [5] *ODVA*, par. 10-10 options [2] and [3] are available. Instances 100/150 and 101/151 are Danfoss-specific. Instances 20/70 and 21/71 are ODVA-specific AC Drive profiles. For guidelines in telegram selection, please refer to the DeviceNet Operating Instructions. Note that a change to this parameter will be executed immediately.

**10-11 Process Data Config Write**

**Option:**

- \*0 None
- 3-02 Minimum reference
- 3-03 Maximum reference
- 3-12 Catch up/slow down value
- 3-41 Ramp 1 ramp up time
- 3-42 Ramp 1 ramp down time
- 3-51 Ramp 2 ramp up time
- 3-52 Ramp 2 ramp down time
- 3-80 Jog ramp time

\* default setting ( ) display text [ ] value for use in communication via serial communication port

## — How to Programme —

3-81 Quick stop ramp time  
 4-11 Motor speed low limit (RPM)  
 4-13 Motor speed high limit (RPM)  
 4-16 Torque limit motor mode  
 4-17 Torque limit generator mode  
 7-28 Minimum Feedback  
 7-29 Maximum Feedback  
 8-90 Bus Jog 1 Speed  
 8-91 Bus Jog 2 Speed  
 16-80 Fieldbus CTW 1 (Fixed)  
 16-82 Fieldbus REF 1 (Fixed)  
 34-01 PCD 1 Write to MCO  
 34-02 PCD 2 Write to MCO  
 34-03 PCD 3 Write to MCO  
 34-04 PCD 4 Write to MCO  
 34-05 PCD 5 Write to MCO  
 34-06 PCD 6 Write to MCO  
 34-07 PCD 7 Write to MCO  
 34-08 PCD 8 Write to MCO  
 34-09 PCD 9 Write to MCO  
 34-10 PCD 10 Write to MCO

**Function:**

Select the process write data for I/O Assembly Instances 101/151. Elements [2] and [3] of this array can be selected. Elements [0] and [1] of the array are fixed.

**10-12 Process Data Config Read****Option:****\*None**

16-00 Control Word  
 16-01 Reference [Unit]  
 16-02 Reference %  
 16-03 Status Word (Fixed)  
 16-04 Main Actual Value [Unit]  
 16-05 Main Actual Value (%) (Fixed)  
 16-10 Power [kW]  
 16-11 Power [hp]  
 16-12 Motor Voltage  
 16-13 Frequency  
 16-14 Motor Current  
 16-16 Torque  
 16-17 Speed [RPM]  
 16-18 Motor Thermal  
 16-19 KTY Sensor Temperature  
 16-21 Phase Angle  
 16-30 DC Link Voltage  
 16-32 BrakeEnergy/s  
 16-33 BrakeEnergy/2 min  
 16-34 Heatsink Temp.  
 16-35 Inverter Thermal  
 16-38 SL Control State  
 16-39 Controlcard Temp.

16-50 External Reference  
 16-51 Pulse Reference  
 16-52 Feedback [Unit]  
 16-53 Digi Pot Reference  
 16-60 Digital Input  
 16-61 Terminal 53 Switch Setting  
 16-62 Analog Input 53  
 16-63 Terminal 54 Switch Setting  
 16-64 Analog Input 54  
 16-65 Analog Output 42 [mA]  
 16-66 Digital Output [bin]  
 16-67 Freq. Input #29 [Hz]  
 16-68 Freq. Input #33 [Hz]  
 16-69 Pulse Output #27 [Hz]  
 16-70 Pulse Output #29 [Hz]  
 16-71 Relay Output [bin]  
 16-84 Comm Option STW  
 16-85 FC Port CTW 1  
 16-90 Alarm Word  
 16-91 Alarm Word 2  
 16-92 Warning Word  
 16-93 Warning Word 2  
 16-94 Extended Status Word  
 16-95 Extended Status Word 2  
 34-21 PCD 1 Read from MCO  
 34-22 PCD 2 Read from MCO  
 34-23 PCD 3 Read from MCO  
 34-24 PCD 4 Read from MCO  
 34-25 PCD 5 Read from MCO  
 34-26 PCD 6 Read from MCO  
 34-27 PCD 7 Read from MCO  
 34-28 PCD 8 Read from MCO  
 34-29 PCD 9 Read from MCO  
 34-30 PCD 10 Read from MCO  
 34-40 Digital Inputs  
 34-41 Digital Outputs  
 34-50 Actual Position  
 34-51 Commanded Position  
 34-52 Actual Master Position  
 34-53 Slave Index Position  
 34-54 Master Index Position  
 34-55 Curve Position  
 34-56 Track Error  
 34-57 Synchronizing Error  
 34-58 Actual Velocity  
 34-59 Actual Master Velocity  
 34-60 Synchronizing Status  
 34-61 Axis Status  
 34-62 Program Status

**Function:**

Select the process read data for I/O Assembly Instances 101/151. Elements [2] and [3] of

\* default setting ( ) display text [ ] value for use in communication via serial communication port

— How to Programme —

this array can be selected. Elements [0] and [1] of the array are fixed.

**10-13 Warning Parameter**

**Range:**

0 - 65535 N/A \*0N/A

**Function:**

View a DeviceNet-specific Warning word. One bit is assigned to every warning. Please refer to the DeviceNet Operating Instructions (MG.33.DX.YY) for further information.

Bit:	Meaning:
0	Bus not active
1	Explicit connection timeout
2	I/O connection
3	Retry limit reached
4	Actual is not updated
5	CAN bus off
6	I/O send error
7	Initialization error
8	No bus supply
9	Bus off
10	Error passive
11	Error warning
12	Duplicate MAC ID Error
13	RX queue overrun
14	TX queue overrun
15	CAN overrun

**10-14 Net Reference**

**Option:**

Read only from LCP.  
 \*Off [0]  
 On [1]

**Function:**

Select the reference source in Instance 21/71 and 20/70.  
 Select *Off* [0] to enable reference via analog/digital inputs.  
 Select *On* [1] to enable reference via the fieldbus.

**10-15 Net Control**

**Option:**

Read only from LCP.  
 \*Off [0]  
 On [1]

**Function:**

Select the control source in Instance 21/71 and 20-70.  
 Select *Off* [0] to enable control via analog/digital inputs.  
 Select *On* [1] to enable control via the fieldbus.

□ **10-2\* COS Filters**

Parameters for configuring COS filter settings.

**10-20 COS Filter 1**

**Range:**

0 - FFFF \*FFFF

**Function:**

Enter the value for COS Filter 1 to set up the filter mask for the Status Word. When operating in COS (Change-Of-State), this function filters out bits in the Status Word that should not be sent if they change.

**10-21 COS Filter 2**

**Range:**

0 - FFFF \*FFFF

**Function:**

Enter the value for COS Filter 2, to set up the filter mask for the Main Actual Value. When operating in COS (Change-Of-State), this function filters out bits in the Main Actual Value that should not be sent if they change.

**10-22 COS Filter 3**

**Range:**

0 - FFFF \*FFFF

**Function:**

Enter the value for COS Filter 3, to set up the filter mask for PCD 3. When operating in COS (Change-Of-State), this function filters out bits in PCD 3 that should not be sent if they change.

**10-23 COS Filter 4**

**Range:**

0 - FFFF \*FFFF

**Function:**

Enter the value for COS Filter 4 to set up the filter mask for PCD 4. When operating in COS (Change-Of-State), this function filters out bits in PCD 4 that should not be sent if they change.

\* default setting ( ) display text [ ] value for use in communication via serial communication port

□ **10-3\* Parameter Access**

Parameter group providing access to indexed parameters and defining programming set-up.

**10-30 Array Index**

**Range:**

0 - 255 N/A \*0N/A

**Function:**

View array parameters. This parameter is valid only when a DeviceNet fieldbus is installed.

**10-31 Store Data Values**

**Option:**

- \*Off [0]
- Store edit setup [1]
- Store all setups [2]

**Function:**

Parameter values changed via DeviceNet are not automatically stored in non-volatile memory. Use this parameter to activate a function that stores parameter values in the EEPROM non-volatile memory, so changed parameter values will be retained at power-down. Select *Off* [0] to deactivate the non-volatile storage function. Select *Store edit setup* [1] to store all parameter values from the active set-up in the non-volatile memory. The selection returns to *Off* [0] when all values have been stored. Select *Store all set-ups* [2] to store all parameter values for all set-ups in the non-volatile memory. The selection returns to *Off* [0] when all parameter values have been stored.

**10-32 Devicenet Revision**

**Range:**

0 - 65535 N/A \*0N/A

**Function:**

View the DeviceNet revision number. This parameter is used for EDS file creation.

**10-33 Store Always**

**Option:**

- \*Off [0]
- On [1]

**Function:**

Select [0] to deactivate non-volatile storage of data. Select [1] to store parameter data received via DeviceNet in EEPROM non-volatile memory as default.

**10-39 Devicenet F Parameters**

Array [1000]

**Option:**

No LCP access \*0  
0 - 0

**Function:**

This parameter is used to configure the drive via Devicenet and build the EDS-file.

\* default setting ( ) display text [ ] value for use in communication via serial communication port

## Parameters: Smart Logic Control

### 13-\*\* Prog. Features

Smart Logic Control (SLC) is essentially a sequence of user defined actions (see par. 13-52 [x]) executed by the SLC when the associated user defined *event* (see par. 13-51 [x]) is evaluated as TRUE by the SLC. Events and *actions* are each numbered and linked together in pairs. This means that when *event* [0] is fulfilled (attains the value TRUE), *action* [0] is executed. After this, the conditions of *event* [1] will be evaluated and if evaluated TRUE, *action* [1] will be executed and so on. Only one *event* will be evaluated at any time. If an *event* is evaluated as FALSE, nothing happens (in the SLC) during the current scan interval and no other *events* will be evaluated. This means that when the SLC starts, it evaluates *event* [0] (and only *event* [0]) each scan interval. Only when *event* [0] is evaluated TRUE, will the SLC execute *action* [0] and start evaluating *event* [1]. It is possible to programme from 1 to 20 *events* and *actions*. When the last *event / action* has been executed, the sequence starts over again from *event* [0] / *action* [0]. The illustration shows an example with three event / actions:

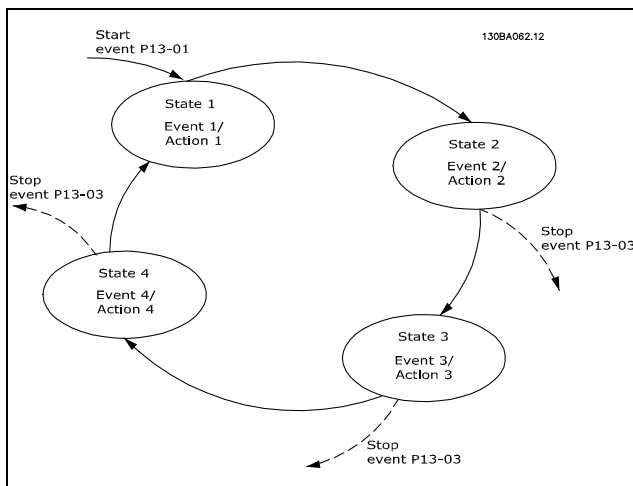

### Starting and stopping the SLC:

Starting and stopping the SLC can be done by selecting .On [1]. or .Off [0]. in par. 13-00. The SLC always starts in state 0 (where it evaluates *event* [0]). The SLC starts when the Start Event (defined in par. 13-01 *Start Event*) is evaluated as TRUE (provided that On [1] is selected in par. 13-00). The SLC stops when the *Stop Event*

(par. 13-02) is TRUE. Par. 13-03 resets all SLC parameters and start programming from scratch.

### 13-0\* SLC Settings

Use the SLC settings to activate, deactivate and reset the Smart Logic Control.

#### 13-00 SL Controller Mode

##### Option:

*Off	[0]
On	[1]

##### Function:

Select *On* [1] to enable the Smart Logic Control to start when a start command is present, e.g. via a digital input. Select *Off* [0] to disable the Smart Logic Control.

#### 13-01 Start Event

##### Option:

False	[0]
True	[1]
Running	[2]
In range	[3]
On reference	[4]
Torque limit	[5]
Current limit	[6]
Out of current range	[7]
Below I low	[8]
Above I high	[9]
Below speed low	[11]
Above speed high	[12]
Out of feedb. range	[13]
Below feedb. low	[14]
Above feedb. high	[15]
Thermal warning	[16]
Mains out of range	[17]
Reversing	[18]
Warning	[19]
Alarm (trip)	[20]
Alarm (trip lock)	[21]
Comparator 0	[22]
Comparator 1	[23]
Comparator 2	[24]
Comparator 3	[25]
Logic rule 0	[26]
Logic rule 1	[27]
Logic rule 2	[28]
Logic rule 3	[29]
Digital input DI18	[33]
Digital input DI19	[34]
Digital input DI27	[35]
Digital input DI29 (FC 302 only)	[36]

\* default setting ( ) display text [ ] value for use in communication via serial communication port

— How to Programme —

Digital input DI32	[37]
Digital input DI33	[38]
Start command	[39]
Stop command	[40]

**Function:**

Select the boolean (TRUE or FALSE) input to activate Smart Logic Control.

*\*False* [0] (default setting) enters the fixed value of FALSE in the logic rule.

*True* [1] enters the fixed value TRUE in the logic rule.

*Running* [2] See parameter group 5-3\* for further description.

*In range* [3] See parameter group 5-3\* for further description.

*On reference* [4] See parameter group 5-3\* for further description.

*Torque limit* [5] See parameter group 5-3\* for further description.

*Current limit* [6] See parameter group 5-3\* for further description.

*Out of current range* [7] See parameter group 5-3\* for further description.

*Below I low* [8] See parameter group 5-3\* for further description.

*Above I high* [9] See parameter group 5-3\* for further description.

*Below frequency low* [11] See parameter group 5-3\* for further description.

*Above frequency high* [12] See parameter group 5-3\* for further description.

*Thermal warning* [16] See parameter group 5-3\* for further description.

*Mains voltage out of range* [17] See parameter group 5-3\* for further description.

*Reversing* [18] See parameter group 5-3\* for further description.

*Warning* [19] See parameter group 5-3\* for further description.

*Alarm (trip)* [20] See parameter group 5-3\* for further description.

*Alarm (trip lock)* [21] See parameter group 5-3\* for further description.

*Comparator 0* [22] Use the result of comparator 0 in the logic rule.

*Comparator 1* [23] Use the result of comparator 1 in the logic rule.

*Comparator 2* [24] Use the result of comparator 2 in the logic rule.

*Comparator 3* [25] Use the result of comparator 3 in the logic rule.

*Logic rule 0* [26] Use the result of logic rule 0 in the logic rule.

*Logic rule 1* [27] Use the result of logic rule 1 in the logic rule.

*Logic rule 2* [28] Use the result of logic rule 2 in the logic rule.

*Logic rule 3* [29] Use the result of logic rule 3 in the logic rule.

*Digital input DI18* [33] Use the value of DI18 in the logic rule (High = TRUE).

*Digital input DI19* [34] Use the value of DI19 in the logic rule (High = TRUE).

*Digital input DI27* [35] Use the value of DI27 in the logic rule (High = TRUE).

*Digital input DI29* [36] Use the value of DI29 in the logic rule (High = TRUE).

*Digital input DI32* [37] Use the value of DI32 in the logic rule (High = TRUE).

*Digital input DI33* [38] Use the value of DI33 in the logic rule (High = TRUE).

**13-02 Stop Event**

**Option:**

False	[0]
True	[1]
Running	[2]
In range	[3]
On reference	[4]
Torque limit	[5]
Current limit	[6]
Out of current range	[7]
Below I low	[8]
Above I high	[9]
Below speed low	[11]
Above speed high	[12]
Out of feedb. range	[13]
Below feedb. low	[14]
Above feedb. high	[15]
Thermal warning	[16]
Mains out of range	[17]
Reversing	[18]
Warning	[19]
Alarm (trip)	[20]
Alarm (trip lock)	[21]
Comparator 0	[22]
Comparator 1	[23]
Comparator 2	[24]
Comparator 3	[25]
Logic rule 0	[26]
Logic rule 1	[27]
Logic rule 2	[28]
Logic rule 3	[29]
SL Time-out 0	[30]
SL Time-out 1	[31]

\* default setting ( ) display text [ ] value for use in communication via serial communication port

— How to Programme —

SL Time-out 2	[32]
Digital input DI18	[33]
Digital input DI19	[34]
Digital input DI27	[35]
Digital input DI29 (FC 302 only)	[36]
Digital input DI32	[37]
Digital input DI33	[38]
Start command	[39]
Stop command	[40]

**Function:**

Select the boolean (TRUE or FALSE) input to activate Smart Logic Control.

*\*False* [0] (default setting) enters the fixed value of FALSE in the logic rule.

*True* [1] enters the fixed value TRUE in the logic rule.

*Running* [2] See parameter group 5-3\* for further description.

*In range* [3] See parameter group 5-3\* for further description.

*On reference* [4] See parameter group 5-3\* for further description.

*Torque limit* [5] See parameter group 5-3\* for further description.

*Current limit* [6] See parameter group 5-3\* for further description.

*Out of current range* [7] See parameter group 5-3\* for further description.

*Below I low* [8] See parameter group 5-3\* for further description.

*Above I high* [9] See parameter group 5-3\* for further description.

*Below frequency low* [11] See parameter group 5-3\* for further description.

*Above frequency high* [12] See parameter group 5-3\* for further description.

*Thermal warning* [16] See parameter group 5-3\* for further description.

*Mains voltage out of range* [17] See parameter group 5-3\* for further description.

*Reversing* [18] See parameter group 5-3\* for further description.

*Warning* [19] See parameter group 5-3\* for further description.

*Alarm (trip)* [20] See parameter group 5-3\* for further description.

*Alarm (trip lock)* [21] See parameter group 5-3\* for further description.

*Comparator 0* [22] Use the result of comparator 0 in the logic rule.

*Comparator 1* [23] Use the result of comparator 1 in the logic rule.

*Comparator 2* [24] Use the result of comparator 2 in the logic rule.

*Comparator 3* [25] Use the result of comparator 3 in the logic rule.

*Logic rule 0* [26] Use the result of logic rule 0 in the logic rule.

*Logic rule 1* [27] Use the result of logic rule 1 in the logic rule.

*Logic rule 2* [28] Use the result of logic rule 2 in the logic rule.

*Logic rule 3* [29] Use the result of logic rule 3 in the logic rule.

*Digital input DI18* [33] Use the value of DI18 in the logic rule (High = TRUE).

*Digital input DI19* [34] Use the value of DI19 in the logic rule (High = TRUE).

*Digital input DI27* [35] Use the value of DI27 in the logic rule (High = TRUE).

*Digital input DI29* [36] Use the value of DI29 in the logic rule (High = TRUE).

*Digital input DI32* [37] Use the value of DI32 in the logic rule (High = TRUE).

*Digital input DI33* [38] Use the value of DI33 in the logic rule (High = TRUE).

**13-03 Reset SLC**

**Option:**

<i>*Do not reset SLC</i>	[0]
Reset SLC	[1]

**Function:**

Select *Reset SLC* [1] to reset all group 13 parameters (13-\*) to default settings.

Select *\*Do not reset SLC* [0] to retain the programmed settings in all group 13 parameters (13-\*).

□ **13-1\* Comparators**

Comparators are used for comparing continuous variables (i.e. output frequency, output current, analog input etc.) with fixed preset values. Comparators are evaluated once in each scan interval. Use the result (TRUE or FALSE) directly to define an event (see par. 13-51), or as boolean input in a logic rule (see par. 13-40, 13-42, or 13-44). All parameters in this parameter group are array parameters with index 0 to 3. Select index 0 to programme Comparator 0, select index 1 to programme Comparator 1, and so on.

**\* default setting    ( ) display text    [ ] value for use in communication via serial communication port**



— How to Programme —

**13-10 Comparator Operand**

Array [4]

**Option:**

*DISABLED	[0]
Reference	[1]
Feedback	[2]
Motor speed	[3]
Motor current	[4]
Motor torque	[5]
Motor power	[6]
Motor voltage	[7]
DC-link voltage	[8]
Motor thermal	[9]
VLT thermal	[10]
Heat sink temp.	[11]
Analog input AI53	[12]
Analog input AI54	[13]
Analog input AIFB10	[14]
Analog input AIS24V	[15]
Analog input AICCT	[17]
Pulse input FI29	[18]
Pulse input FI33	[19]
Alarm number	[20]
Counter A	[30]
Counter B	[31]

**Function:**

Select the variable to be monitored by the comparator.  
*\*False* [0] (default setting) enters the fixed value of FALSE in the logic rule.  
*True* [1]. enters the fixed value TRUE in the logic rule.  
*Running* [2] See parameter group 5-3\* for further description.  
*In range* [3] See parameter group 5-3\* for further description.  
*On reference* [4] See parameter group 5-3\* for further description.  
*Torque limit* [5] See parameter group 5-3\* for further description.  
*Current limit* [6] See parameter group 5-3\* for further description.  
*Out of current range* [7] See parameter group 5-3\* for further description.  
*Below I low* [8] See parameter group 5-3\* for further description.  
*Above I high* [9] See parameter group 5-3\* for further description.  
*Below frequency low* [11] See parameter group 5-3\* for further description.

*Above frequency high* [12] See parameter group 5-3\* for further description.  
*Thermal warning* [16] See parameter group 5-3\* for further description.  
*Mains voltage out of range* [17] See parameter group 5-3\* for further description.  
*Reversing* [18] See parameter group 5-3\* for further description.  
*Warning* [19] See parameter group 5-3\* for further description.  
*Alarm (trip)* [20] See parameter group 5-3\* for further description.  
*Alarm (trip lock)* [21] See parameter group 5-3\* for further description.  
*Comparator 0* [22] Use the result of comparator 0 in the logic rule.  
*Comparator 1* [23] Use the result of comparator 1 in the logic rule.  
*Comparator 2* [24] Use the result of comparator 2 in the logic rule.  
*Comparator 3* [25] Use the result of comparator 3 in the logic rule.  
*Logic rule 0* [26] Use the result of logic rule 0 in the logic rule.  
*Logic rule 1* [27] Use the result of logic rule 1 in the logic rule.  
*Logic rule 2* [28] Use the result of logic rule 2 in the logic rule.  
*Logic rule 3* [29] Use the result of logic rule 3 in the logic rule.  
*Digital input DI18* [33] Use the value of DI18 in the logic rule (High = TRUE).  
*Digital input DI19* [34] Use the value of DI19 in the logic rule (High = TRUE).  
*Digital input DI27* [35] Use the value of DI27 in the logic rule (High = TRUE).  
*Digital input DI29* [36] Use the value of DI29 in the logic rule (High = TRUE).  
*Digital input DI32* [37] Use the value of DI32 in the logic rule (High = TRUE).  
*Digital input DI33* [38] Use the value of DI33 in the logic rule (High = TRUE).

**13-11 Comparator Operator**

Array [4]

**Option:**

<	[0]
*≈	[1]
>	[2]

\* default setting ( ) display text [ ] value for use in communication via serial communication port

— How to Programme —

**Function:**

Select the operator to be used in the comparison. Select < [0] for the result of the evaluation to be TRUE, when the variable selected in par. 13-10 is smaller than the fixed value in par. 13-12. The result will be FALSE, if the variable selected in par. 13-10 is greater than the fixed value in par. 13-12. Select > [2] for the inverse logic of option < [0]. Select ≈ [1] for the result of the evaluation to be TRUE, when the variable selected in par. 13-10 is approximately equal to the fixed value in par. 13-12.

**13-12 Comparator Value**

Array [4]

**Range:**

-100000.000 - 100000.000 \*0.000

**Function:**

Enter the 'trigger level' for the variable that is monitored by this comparator. This is an array parameter containing comparator values 0 to 3.

□ **13-2\* Timers**

This parameter group consists of timer parameters. Use the result (TRUE or FALSE) from *timers* directly to define an *event* (see par. 13-51), or as boolean input in a *logic rule* (see par. 13-40, 13-42 or 13-44). A timer is only FALSE when started by an action (i.e. Start timer 1 [29]) until the timer value entered in this parameter is elapsed. Then it becomes TRUE again. All parameters in this parameter group are array parameters with index 0 to 2. Select index 0 to program Timer 0, select index 1 to program Timer 1, and so on.

**13-20 SL Controller Timer**

Array [3]

**Range:**

0.00 - 3600.00 s \*0.00s

**Function:**

Enter the value to define the duration of the FALSE output from the programmed timer. A timer is only FALSE if it is started by an action (i.e. *Start timer 1* [29]) and until the given timer value has elapsed.

□ **13-4\* Logic Rules**

Combine up to three boolean inputs (TRUE / FALSE inputs) from timers, comparators, digital inputs, status bits and events using the logical operators AND, OR, and NOT. Select boolean inputs for

the calculation in par. 13-40, 13-42, and 13-44. Define the operators used to logically combine the selected inputs in par. 13-41 and 13-43.

**Priority of calculation**

The results of par. 13-40, 13-41, and 13-42 are calculated first. The outcome (TRUE / FALSE) of this calculation is combined with the settings of par. 13-43 and 13-44, yielding the final result (TRUE / FALSE) of the logic rule.

**13-40 Logic Rule Boolean 1**

Array [4]

**Option:**

*False	[0]
True	[1]
Running	[2]
In range	[3]
On reference	[4]
Torque limit	[5]
Current limit	[6]
Out of current range	[7]
Below I low	[8]
Above I high	[9]
Out of speed range	[10]
Below speed low	[11]
Above speed high	[12]
Out of feedb. range	[13]
Below feedb. low	[14]
Above feedb. high	[15]
Thermal warning	[16]
Mains voltage out of range	[17]
Reversing	[18]
Warning	[19]
Alarm (trip)	[20]
Alarm (trip lock)	[21]
Comparator 0	[22]
Comparator 1	[23]
Comparator 2	[24]
Comparator 3	[25]
Logic rule 0	[26]
Logic rule 1	[27]
Logic rule 2	[28]
Logic rule 3	[29]
Time-out 0	[30]
Time-out 1	[31]
Time-out 2	[32]
Digital input DI18	[33]
Digital input DI19	[34]
Digital input DI27	[35]
Digital input DI29	[36]
Digital input DI32	[37]

\* default setting ( ) display text [ ] value for use in communication via serial communication port

— How to Programme —

Digital input DI33	[38]
Start command	[39]
Drive stopped	[40]

**Function:**

Select the first boolean (TRUE or FALSE) input for the selected logic rule.

*\*False* [0] (default setting) enters the fixed value of FALSE in the logic rule.

*True* [1] enters the fixed value TRUE in the logic rule.

*Running* [2] See parameter group 5-3\* for further description.

*In range* [3] See parameter group 5-3\* for further description.

*On reference* [4] See parameter group 5-3\* for further description.

*Torque limit* [5] See parameter group 5-3\* for further description.

*Current limit* [6] See parameter group 5-3\* for further description.

*Out of current range* [7] See parameter group 5-3\* for further description.

*Below I low* [8] See parameter group 5-3\* for further description.

*Above I high* [9] See parameter group 5-3\* for further description.

*Out of speed range* [10] See parameter group 5-3\* for further description.

*Below frequency low* [11] See parameter group 5-3\* for further description.

*Above frequency high* [12] See parameter group 5-3\* for further description.

*Out of feedback range* [13] See parameter group 5-3\* for further description.

*Below feedback low* [14] See parameter group 5-3\* for further description.

*Above feedback high* [15] See parameter group 5-3\* for further description.

*Thermal warning* [16] See parameter group 5-3\* for further description.

*Mains voltage out of range* [17] See parameter group 5-3\* for further description.

*Reversing* [18] See parameter group 5-3\* for further description.

*Warning* [19] See parameter group 5-3\* for further description.

*Alarm (trip)* [20] See parameter group 5-3\* for further description.

*Alarm (trip lock)* [21] See parameter group 5-3\* for further description.

*Comparator 0* [22] Use the result of comparator 0 in the logic rule.

*Comparator 1* [23] Use the result of comparator 1 in the logic rule.

*Comparator 2* [24] Use the result of comparator 2 in the logic rule.

*Comparator 3* [25] Use the result of comparator 3 in the logic rule.

*Logic rule 0* [26] Use the result of logic rule 0 in the logic rule.

*Logic rule 1* [27] Use the result of logic rule 1 in the logic rule.

*Logic rule 2* [28] Use the result of logic rule 2 in the logic rule.

*Logic rule 3* [29] Use the result of logic rule 3 in the logic rule.

*Time-out 0* [30] Use the result of timer 0 in the logic rule.

*Time-out 1* [31] Use the result of timer 1 in the logic rule.

*Time-out 2* [32] Use the result of timer 2 in the logic rule.

*Digital input DI18* [33] Use the value of DI18 in the logic rule (High = TRUE).

*Digital input DI19* [34] Use the value of DI19 in the logic rule (High = TRUE).

*Digital input DI27* [35] Use the value of DI27 in the logic rule (High = TRUE).

*Digital input DI29* [36] Use the value of DI29 in the logic rule (High = TRUE).

*Digital input DI32* [37] Use the value of DI32 in the logic rule (High = TRUE).

*Digital input DI33* [38] Use the value of DI33 in the logic rule (High = TRUE).

**13-41 Logic Rule Operator 1**

Array [4]

**Option:**

<b>*Disabled</b>	[0]
And	[1]
Or	[2]
And not	[3]
Or not	[4]
Not and	[5]
Not or	[6]
Not and not	[7]
Not or not	[8]

**Function:**

Select the first logical operator to use on the Boolean inputs from par. 13-40 and 13-42. [13 -XX] signifies the boolean input of par. 13-\*. Select *DISABLED* [0] to ignore par. 13-42, 13-43, and 13-44.

*AND* [1] evaluates the expression [13-40] AND [13-42].

\* default setting ( ) display text [ ] value for use in communication via serial communication port

— How to Programme —

*OR* [2] evaluates the expression [13-40] OR [13-42].  
*AND NOT* [3] evaluates the expression [13-40] AND NOT [13-42].  
*OR NOT* [4] evaluates the expression [13-40] OR NOT [13-42].  
*NOT AND* [5] evaluates the expression NOT [13-40] AND [13-42].  
*NOT OR* [6] evaluates the expression NOT [13-40] OR [13-42].  
*NOT AND NOT* [7] evaluates the expression NOT [13-40] AND NOT [13-42].  
*NOT OR NOT* [8] evaluates the expression NOT [13-40] OR NOT [13-42].

**13-42 Logic Rule Boolean 2**

Array [4]

**Option:**

*False	[0]
True	[1]
Running	[2]
In range	[3]
On reference	[4]
Torque limit	[5]
Current limit	[6]
Out of current range	[7]
Below I low	[8]
Above I high	[9]
Out of speed range	[10]
Below speed low	[11]
Above speed high	[12]
Out of feedb. range	[13]
Below feedb. low	[14]
Above feedb. high	[15]
Thermal warning	[16]
Mains voltage out of range	[17]
Reversing	[18]
Warning	[19]
Alarm (trip)	[20]
Alarm (trip lock)	[21]
Comporator 0	[22]
Comporator 1	[23]
Comporator 2	[24]
Comporator 3	[25]
Logic rule 0	[26]
Logic rule 1	[27]
Logic rule 2	[28]
Logic rule 3	[29]
Time-out 0	[30]
Time-out 1	[31]
Time-out 2	[32]
Digital input DI18	[33]
Digital input DI19	[34]

Digital input DI27	[35]
Digital input DI29	[36]
Digital input DI32	[37]
Digital input DI33	[38]
Start command	[39]
Drive stopped	[40]

**Function:**

Select the second boolean (TRUE or FALSE) input for the selected logic rule. See par. 13-40 for further explanation.

**13-43 Logic Rule Operator 2**

Array [4]

**Option:**

*Disabled	[0]
And	[1]
Or	[2]
And not	[3]
Or not	[4]
Not and	[5]
Not or	[6]
Not and not	[7]
Not or not	[8]

**Function:**

Select the second logical operator to be used on the boolean input calculated in par. 13-40, 13-41, and 13-42, and the boolean input coming from par. 13-42.  
 [13-44] signifies the boolean input of par. 13-44.  
 [13-40/13-42] signifies the boolean input calculated in par. 13-40, 13-41, and 13-42.  
 DISABLED [0] (factory setting). select this option to ignore par. 13-44.  
*AND* [1] evaluates the expression [13-40/13-42] AND [13-44].  
*OR* [2] evaluates the expression [13-40/13-42] OR [13-44].  
*AND NOT* [3] evaluates the expression [13-40/13-42] AND NOT [13-44].  
*OR NOT* [4] evaluates the expression [13-40/13-42] OR NOT [13-44].  
*NOT AND* [5] evaluates the expression NOT [13-40/13-42] AND [13-44].  
*NOT OR* [6] evaluates the expression NOT [13-40/13-42] OR [13-44].  
*NOT AND NOT* [7] evaluates the expression NOT [13-40/13-42] and evaluates AND NOT [13-44].  
*NOT OR NOT* [8] evaluates the expression NOT [13-40/13-42] OR NOT [13-44].

\* default setting ( ) display text [ ] value for use in communication via serial communication port

— How to Programme —

**13-44 Logic Rule Boolean 3**

Array [4]

**Option:**

*False	[0]
True	[1]
Running	[2]
In range	[3]
On reference	[4]
Torque limit	[5]
Current limit	[6]
Out of current range	[7]
Below I low	[8]
Above I high	[9]
Out of speed range	[10]
Below speed low	[11]
Above speed high	[12]
Out of feedb. range	[13]
Below feedb. low	[14]
Above feedb. high	[15]
Thermal warning	[16]
Mains voltage out of range	[17]
Reversing	[18]
Warning	[19]
Alarm (trip)	[20]
Alarm (trip lock)	[21]
Comporator 0	[22]
Comporator 1	[23]
Comporator 2	[24]
Comporator 3	[25]
Logic rule 0	[26]
Logic rule 1	[27]
Logic rule 2	[28]
Logic rule 3	[29]
Time-out 0	[30]
Time-out 1	[31]
Time-out 2	[32]
Digital input DI18	[33]
Digital input DI19	[34]
Digital input DI27	[35]
Digital input DI29	[36]
Digital input DI32	[37]
Digital input DI33	[38]
Start command	[39]
Drive stopped	[40]

**Function:**

Select the third boolean (TRUE or FALSE) input for the selected logic rule.

□ **13-5\* States**

Parameters for programming the Smart Logic Controller.

**13-51 SL Controller Event**

Array [20]

**Option:**

*False	[0]
True	[1]
Running	[2]
In range	[3]
On reference	[4]
Torque limit	[5]
Current limit	[6]
Out of current range	[7]
Below I low	[8]
Above I high	[9]
Out of speed range	[10]
Below speed low	[11]
Above speed high	[12]
Out of feedb. range	[13]
Below feedb. low	[14]
Above feedb. high	[15]
Thermal warning	[16]
Mains voltage out of range	[17]
Reversing	[18]
Warning	[19]
Alarm (trip)	[20]
Alarm (trip lock)	[21]
Comparator 0	[22]
Comparator 1	[23]
Comparator 2	[24]
Comparator 3	[25]
Logic rule 0	[26]
Logic rule 1	[27]
Logic rule 2	[28]
Logic rule 3	[29]
Time-out 0	[30]
Time-out 1	[31]
Time-out 2	[32]
Digital input DI18	[33]
Digital input DI19	[34]
Digital input DI27	[35]
Digital input DI29	[36]
Digital input DI32	[37]
Digital input DI33	[38]
Start command	[39]
Drive stopped	[40]

**Function:**

Select the boolean input (TRUE or FALSE) to define the Smart Logic Controller event.

\*False [0] enters the fixed value FALSE in the event.

True [1] enters the fixed value TRUE in the event.

Running [2] See parameter group 5-3\* for further description.

\* default setting ( ) display text [ ] value for use in communication via serial communication port

— How to Programme —

*In range* [3] See parameter group 5-3\* for further description.  
*On reference* [4] See parameter group 5-3\* for further description.  
*Torque limit* [5] See parameter group 5-3\* for further description.  
*Current limit* [6] See parameter group 5-3\* for further description.  
*Out of current range* [7] See parameter group 5-3\* for further description.  
*Above I low* [8] See parameter group 5-3\* for further description.  
*Below I high* [9] See parameter group 5-3\* for further description.  
*Out of speed range* [10] See parameter group 5-3\* for further description.  
*Above frequency low* [11] See parameter group 5-3\* for further description.  
*Below frequency high* [12] See parameter group 5-3\* for further description.  
*Out of feedback range* [13] See parameter group 5-3\* for further description.  
*Below feedback low* [14] See parameter group 5-3\* for further description.  
*Above feedback high* [15] See parameter group 5-3\* for further description.  
*Thermal warning* [16] See parameter group 5-3\* for further description.  
*Mains voltage out of range* [17] See parameter group 5-3\* for further description.  
*Reversing* [18] See parameter group 5-3\* for further description.  
*Warning* [19] See parameter group 5-3\* for further description.  
*Alarm (trip)* [20] See parameter group 5-3\* for further description.  
*Alarm (trip lock)* [21] See parameter group 5-3\* for further description.  
*Comparator 0* [22] Use the result of comparator 0 in the event.  
*Comparator 1* [23] Use the result of comparator 1 in the event.  
*Comparator 2* [24] Use the result of comparator 2 in the event.  
*Comparator 3* [25] Use the result of comparator 3 in the event.  
*Logic rule 0* [26] Use the result of logic rule 0 in the event.  
*Logic rule 1* [27] Use the result of logic rule 1 in the event.  
*Logic rule 2* [28] Use the result of logic rule 2 in the event.  
*Logic rule 3* [29] Use the result of logic rule 3 in the event.

*Time-out 0* [30] Use the result of timer 0 in the event.  
*Time-out 1* [31] Use the result of timer 1 in the event.  
*Time-out 2* [32] Use the result of timer 2 in the event.  
*Digital input DI18* [33] Use the value of DI18 in the event (High = TRUE).  
*Digital input DI19* [34] Use the value of DI19 in the event (High = TRUE).  
*Digital input DI27* [35] Use the value of DI27 in the event (High = TRUE).  
*Digital input DI29* [36] Use the value of DI29 in the event (High = TRUE).  
*Digital input DI32* [37] Use the value of DI32 in the event (High = TRUE).  
*Digital input DI33* [38] Use the value of DI33 in the event (High = TRUE).  
*Start command* [39] This event is TRUE if the frequency converter is started by any means (either via digital input, field bus or other).  
*Drive stopped* [40] This event is TRUE if the frequency converter is stopped or coasted by any means (either via digital input, fieldbus or other).

**13-52 SL Controller Action**

Array [20]

**Option:**

* Disabled	[0]
No action	[1]
Select set-up 0	[2]
Select set-up 1	[3]
Select set-up 2	[4]
Select set-up 3	[5]
Select preset reference 0	[10]
Select preset reference 1	[11]
Select preset reference 2	[12]
Select preset reference 3	[13]
Select preset reference 4	[14]
Select preset reference 5	[15]
Select preset reference 6	[16]
Select preset reference 7	[17]
Select ramp 1	[18]
Select ramp 2	[19]
Select ramp 3	[20]
Select ramp 4	[21]
Run	[22]
Run reverse	[23]
Stop	[24]
Qstop	[25]
Dcstop	[26]
Coast	[27]
Freeze output	[28]
Start timer 0	[29]
Start timer 1	[30]

\* default setting    ( ) display text    [ ] value for use in communication via serial communication port

## — How to Programme —

Start timer 2	[31]
Set digital output A low	[32]
Set digital output B low	[33]
Set digital output C low	[34]
Set digital output D low	[35]
Set digital output E low	[36]
Set digital output F low	[37]
Set digital output A high	[38]
Set digital output B high	[39]
Set digital output C high	[40]
Set digital output D high	[41]
Set digital output E high	[42]
Set digital output F high	[43]
Reset Counter A	[60]
Reset Counter B	[61]

**Function:**

Select the action corresponding to the SLC event. Actions are executed when the corresponding event (defined in par. 13-51) is evaluated as true. The following actions are available for selection:

\**DISABLED* [0]

*No action* [1]

*Select set-up 1* [2] - changes the active set-up (par. 0-10) to '1'.

*Select set-up 2* [3] - changes the active set-up (par. 0-10) to '2'.

*Select set-up 3* [4] - changes the active set-up (par. 0-10) to '3'.

*Select set-up 4* [5] - changes the active set-up (par. 0-10) to '4'. If the set-up is changed, it will merge with other set-up commands coming from either the digital inputs or via a fieldbus.

*Select preset reference 0* [10] - selects preset reference 0.

*Select preset reference 1* [11] - selects preset reference 1.

*Select preset reference 2* [12] - selects preset reference 2.

*Select preset reference 3* [13] - selects preset reference 3.

*Select preset reference 4* [14] - selects preset reference 4.

*Select preset reference 5* [15] - selects preset reference 5.

*Select preset reference 6* [16] - selects preset reference 6.

*Select preset reference 7* [17] - selects preset reference 7. If the active preset reference is changed, it will merge with other preset reference commands coming from either the digital inputs or via a fieldbus.

*Select ramp 1* [18] - selects ramp 1.

*Select ramp 2* [19] - selects ramp 2.

*Select ramp 3* [20] - selects ramp 3.

*Select ramp 4* [21] - selects ramp 4.

*Run* [22] - issues a start command to the frequency converter.

*Run reverse* [23] - issues a start reverse command to the frequency converter.

*Stop* [24] - issues a stop command to the frequency converter.

*Qstop* [25] - issues a quick stop command to the frequency converter.

*Dcstop* [26] - issues a DC stop command to the frequency converter.

*Coast* [27] - the frequency converter coasts immediately. All stop commands including the coast command stop the SLC.

*Freeze output* [28] - freezes the output frequency of the frequency converter.

*Start timer 0* [29] - starts timer 0, see par. 13-20 for further description.

*Start timer 1* [30] - starts timer 1, see par. 13-20 for further description.

*Start timer 2* [31] - starts timer 2, see par. 13-20 for further description.

*Set digital output A low* [32] - any output with 'digital output 1' selected is low (off).

*Set digital output B low* [33] - any output with 'digital output 2' selected is low (off).

*Set digital output C low* [34] - any output with 'digital output 3' selected is low (off).

*Set digital output D low* [35] - any output with 'digital output 4' selected is low (off).

*Set digital output E low* [36] - any output with 'digital output 5' selected is low (off).

*Set digital output F low* [37] - any output with 'digital output 6' selected is low (off).

*Set digital output A high* [38] - any output with 'digital output 1' selected is high (closed).

*Set digital output B high* [39] - any output with 'digital output 2' selected is high (closed).

*Set digital output C high* [40] - any output with 'digital output 3' selected is high (closed).

*Set digital output D high* [41] - any output with 'digital output 4' selected is high (closed).

*Set digital output E high* [42] - any output with 'digital output 5' selected is high (closed).

*Set digital output F high* [43] - any output with 'digital output 6' selected is high (closed).

*Reset Counter A* [60] - resets Counter A to zero.

*Reset Counter B* [61] - resets Counter B to zero.

\* default setting ( ) display text [ ] value for use in communication via serial communication port

□ **Parameters: Special Functions**

□ **14-\*\* Special Functions**

Parameter group for configuring special frequency converter functions.

□ **14-0\* Inverter Switching**

Parameters for configuring the inverter switching.

**14-00 Switching Pattern**

**Option:**

60 AVM	[0]
*SFAVM	[1]

**Function:**

Select the switching pattern: 60° AVM or SFAVM.

**14-01 Switching Frequency**

**Option:**

1.0 kHz	[0]
1.5 kHz	[1]
2.0 kHz	[2]
2.5 kHz	[3]
3.0 kHz	[4]
3.5 kHz	[5]
4.0 kHz	[6]
5.0 kHz	[7]
6.0 kHz	[8]
7.0 kHz	[9]
8.0 kHz	[10]
10.0 kHz	[11]
12.0 kHz	[12]
14.0 kHz	[13]
16.0 kHz	[14]

**Function:**

Select the inverter switching frequency. Changing the switching frequency can help to reduce acoustic noise from the motor.



**NB!:**

The output frequency value of the frequency converter must never exceed 1/10 of the switching frequency. When the motor is running, adjust the switching frequency in par. 4-11 until the motor is as noiseless as possible. See also par. 14-00 and the section *Derating*.



**NB!:**

Switching frequencies higher than 5.0 kHz lead to automatic derating of the maximum output of the frequency converter.

**14-03 Overmodulation**

**Option:**

Off	[0]
*On	[1]

**Function:**

Select *On* [1] to connect the overmodulation function for the output voltage, to obtain an output voltage up to 15% greater than the mains voltage. Select *Off* [0] for no overmodulation of the output voltage, in order to avoid torque ripple on the motor shaft. This feature may be useful for applications such as grinding machines.

**14-04 PWM Random**

**Option:**

*Off	[0]
On	[1]

**Function:**

Select *On* [1] to transform the acoustic motor switching noise from a clear ring tone into a less discernable 'white' noise. This is achieved by slightly and randomly altering the synchronism of the pulse width modulated output phases. Select *Off* [0] for no change to the acoustic motor switching noise.

□ **14-1\* Mains On/Off**

Parameters for configuring mains failure monitoring and handling.

**14-12 Function at Mains Imbalance**

**Option:**

*Trip	[0]
Warning	[1]
Disabled	[2]

**Function:**

When a severe mains imbalance is detected: Select *Trip* [0] to trip the frequency converter; Select *Warning* [1] to issue a warning; or Select *Disabled* [2] for no action. Operation under severe main imbalance conditions reduces the lifetime of the motor. Conditions are considered severe if the motor is operated continuously near nominal load (e.g. a pump or fan running near full speed).

□ **14-2\* Trip Reset**

Parameters for configuring auto reset handling, special trip handling and control card self test or initialisation.

\* default setting ( ) display text [ ] value for use in communication via serial communication port



— How to Programme —

**14-20 Reset Mode**

**Option:**

* Manual reset	[0]
Automatic reset x 1	[1]
Automatic reset x 2	[2]
Automatic reset x 3	[3]
Automatic reset x 4	[4]
Automatic reset x 5	[5]
Automatic reset x 6	[6]
Automatic reset x 7	[7]
Automatic reset x 8	[8]
Automatic reset x 9	[9]
Automatic reset x 10	[10]
Automatic reset x 15	[11]
Automatic reset x 20	[12]
Infinite Automatic Reset	[13]

**Function:**

Select the reset function after tripping. Once reset, the frequency converter can be restarted. Select *Manual reset* [0], to perform a reset via [RESET] or via the digital inputs. Select *Automatic reset x 1...x20* [1]-[12] to perform between one and twenty automatic resets after tripping. Select *Infinite Automatic Reset* [13] for continuous resetting after tripping.



**NB!:**

If the specified number of AUTOMATIC RESETs is reached within 10 minutes, the frequency converter enters Manual reset [0] mode. After the Manual reset is performed, the setting of par. 14-20 reverts to the original selection. If the number of AUTOMATIC RESETs is not reached within 10 minutes, or when a Manual reset is performed, the internal AUTOMATIC RESET counter returns to zero.

The motor may start without warning.

**14-21 Automatic Restart Time**

**Range:**

0 - 600 s \*10s

**Function:**

Enter the time interval from trip to start of the automatic reset function. This parameter is active when par. 14-20 is set to *Automatic reset* [1] - [13].

**14-22 Operation Mode**

**Option:**

* Normal operation	[0]
Control card test	[1]

Initialisation [2]

**Function:**

Use this parameter to specify normal operation; to perform tests; or to initialise all parameters except par. 15-03, 15-04 and 15-05. This function is active only when the power is cycled to the frequency converter. Select *Normal operation* [0] for normal operation of the frequency converter with the motor in the selected application. Select *Control card test* [1] to test the analog and digital inputs and outputs and the +10 V control voltage. The test requires a test connector with internal connections. Use the following procedure for the control card test:

1. Select *Control card test* [1].
2. Disconnect the mains supply and wait for the light in the display to go out.
3. Set switches S201 (A53) and S202 (A54) = 'ON' / I.
4. Insert the test plug (see below).
5. Connect to mains supply.
6. Carry out various tests.
7. The results are displayed on the LCP and the frequency converter moves into an infinite loop.
8. Par. 14-22 is automatically set to Normal operation. Carry out a power cycle to start up in Normal operation after a control card test.

**If the test is OK:**

LCP read-out: Control Card OK.  
Disconnect the mains supply and remove the test plug. The green LED on the Control Card will light up.

**If the test fails:**

LCP read-out: Control Card I/O failure.  
Replace the frequency converter or Control card. The red LED on the Control Card is turned on. Test plugs (connect the following terminals to each other): 18 - 27 - 32; 19 - 29 - 33; 42 - 53 - 54

\* default setting ( ) display text [ ] value for use in communication via serial communication port

— How to Programme —

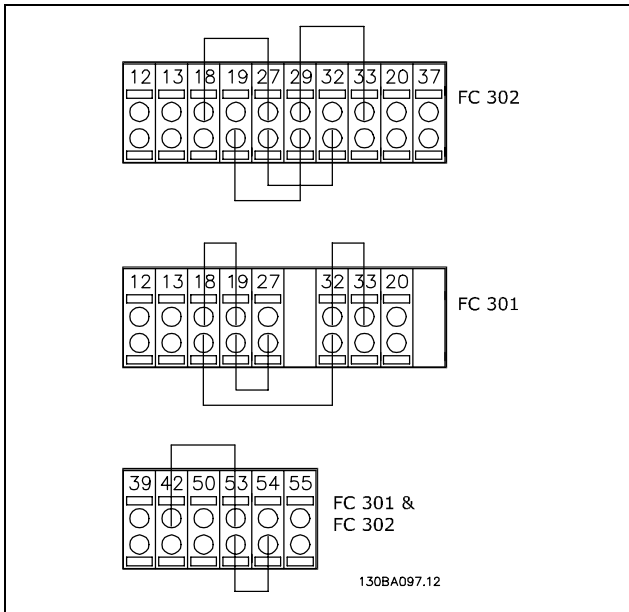

When the current limit is reached during motor operation or regenerative operation, the frequency converter will try to reduce torque below the preset torque limits as quickly as possible without losing control of the motor.

While the current control is active, the frequency converter can only be stopped by setting a digital input to *Coast inverse* [2] or *Coast and reset inv.* [3]. Any signal on terminals 18 to 33 will not be active until the frequency converter is no longer near the current limit.

By using a digital input set to *Coast inverse* [2] or *Coast and reset inv.* [3], the motor does not use the ramp-down time, since the drive is coasted. If a quick stop is necessary, use the mechanical brake control function along with an external electro-mechanical brake attached to the application.

Select *Initialization* [2] to reset all parameter values to default settings, except for par. 15-03, 15-04, and 15-05. The frequency converter will reset during the next power-up.

Par. 14-22 will also revert to the default setting *Normal operation* [0].

**14-25 Trip Delay at Torque Limit**

**Option:**  
0 - 60 s \* 60 s

**Function:**  
Enter the torque limit trip delay in seconds. When the output torque reaches the torque limits (par. 4-16 and 4-17), a warning is triggered. When the torque limit warning has been continuously present for the period specified in this parameter, the frequency converter trips. Disable the trip delay by setting the parameter to 60 s = OFF. Thermal frequency converter monitoring will still remain active.

**14-26 Trip Delay at Inverter Fault**

**Option:**  
0 - 30 s \* 5s

**Function:**  
When the frequency converter detects an over-voltage in the set time trip will be effected after the set time.

□ **14-3\* Current Limit Control**

The FC 300 Series features an integral Current Limit Controller which is activated when the motor current, and thus the torque, is higher than the torque limits set in par. 4-16 and 4-17.

**14-30 Current Lim Cont, Proportional Gain**

**Option:**  
0 - 500 % \* 100 %

**Function:**  
Enter the proportional gain value for the current limit controller. Selection of a high value makes the controller react faster. Too high a setting leads to controller instability.

**14-31 Current Lim Contr, Integration Time**

**Option:**  
0.002 - 2.000 s \* 0.020 s

**Function:**  
Controls the current limit control integration time. Setting it to a lower value makes it react faster. A setting too low leads to control instability.

□ **14-4\* Energy Optimising**

Parameters for adjusting the energy optimisation level in both Variable Torque (VT) and Automatic Energy Optimization (AEO) mode.

**14-40 VT Level**

**Range:**  
40 - 90% \* 66%

**Function:**  
Enter the level of motor magnetisation at low speed. Selection of a low value reduces energy loss in the motor, but also reduces load capability. This parameter cannot be adjusted while the motor is running.

\* default setting ( ) display text [ ] value for use in communication via serial communication port

— How to Programme —

**14-41 AEO Minimum Magnetisation**

**Range:**  
40 - 75% \*40%

**Function:**  
Enter the minimum allowable magnetisation for AEO. Selection of a low value reduces energy loss in the motor, but can also reduce resistance to sudden load changes.

**14-42 Minimum AEO Frequency**

**Range:**  
5 - 40 Hz \*10Hz

**Function:**  
Enter the minimum frequency at which the Automatic Energy Optimisation (AEO) is to be active.

**14-43 Motor Cosphi**

**Range:**  
0.40 - 0.95 N/A \*0.66N/A

**Function:**  
The Cos(phi) setpoint is automatically set for optimum AEO performance. This parameter should normally not be altered. However in some situations it may be necessary to enter a new value to fine-tune.

□ **14-5\* Environment**

Set these parameters to *On* [1] to ensure the frequency converter complies with EMC standards. Select *Off* [0] only when the frequency converter is supplied from an isolated mains source, i.e. IT mains.

**14-50 RFI 1**

**Option:**  
Off [0]  
\*On [1]

**Function:**  
Select *On* [1] to ensure the frequency converter complies with EMC standards. Select *Off* [0] only when the frequency converter is supplied from an isolated mains source, i.e. IT mains. In this mode, the internal RFI capacities (filter capacitors) between chassis and the Mains RFI Filter circuit are cut off to avoid damage to the intermediate circuit and to reduce the earth capacity currents (according to IEC 61800-3). This parameter is available for FC 302 only.

**14-52 Fan Control**

**Option:**  
\*Auto [0]  
On 50% [1]  
On 75% [2]  
On 100% [3]

**Function:**  
Select the minimum speed of the internal fan. Select *Auto* [0] to run the fan only when the internal temperature of the frequency converter is in the range 35 °C – approx. 55°C. The fan will run at low speed at 35C, and at full speed at approx. 55°C.

\* default setting ( ) display text [ ] value for use in communication via serial communication port

□ **Parameters: Drive Information**

□ **15-\*\* Operating Data**

Parameter group containing frequency converter information such as operating data, hardware configuration and software versions.

□ **15-0\* Operating Data**

Parameter group containing operating data e.g. Operating Hours, kWh counters, Power Ups, etc.

**15-00 Operating Hours**

**Range:**  
0 - 2147483647 h \*0h

**Function:**  
View how many hours the frequency converter has run. The value is saved when the frequency converter is turned off.

**15-01 Running Hours**

**Range:**  
0 - 2147483647 h \* 0h

**Function:**  
View how many hours the motor has run. Reset the counter in par. 15-07. The value is saved when the frequency converter is turned off.

**15-02 kWh Counter**

**Range:**  
0 - 2147483647 kWh \* 0kWh

**Function:**  
View the power consumption from mains in kWh as a mean value over one hour. Reset the counter in par. 15-06.

**15-03 Power Up's**

**Range:**  
0 - 2147483647 \*0

**Function:**  
View the number of times the frequency converter has been powered up.

**15-04 Over Temp's**

**Range:**  
0 - 65535 \*0

**Function:**  
View the number of frequency converter temperature faults which have occurred.

**15-05 Over Volt's**

**Range:**  
0 - 65535 \*0

**Function:**  
View the number of frequency converter overvoltages which have occurred.

**15-06 Reset kWh Counter**

**Option:**  
\*Do not reset [0]  
Reset counter [1]

**Function:**  
Select *Reset* [1] and press [OK] to reset the kWh counter to zero (see par 15-02). This parameter cannot be selected via the serial port, RS 485. Select *Do not reset* [0] if no reset of the kWh counter is desired.



**NB!:**  
The reset is carried out by pressing [OK].

**15-07 Reset Running Hours Counter**

**Option:**  
\*Do not reset [0]  
Reset counter [1]

**Function:**  
Select *Reset* [1] and press [OK] to reset the Running Hours counter to zero (see par. 15-01). This parameter cannot be selected via the serial port, RS 485. Select *Do not reset* [0] if no reset of the Running Hours counter is desired.

□ **15-1\* Data Log Settings**

The Data Log enables continuous logging of up to 4 data sources (par. 15-10) at individual rates (par. 15-11). A trigger event (par. 15-12) and window (par. 15-14) are used to start and stop the logging conditionally.

**15-10 Logging Source**

Array [4]

**Option:**  
None  
16-00 Control Word  
16-01 Reference [Unit]  
16-02 Reference %  
16-03 Status Word

\* default setting ( ) display text [ ] value for use in communication via serial communication port

— How to Programme —

- 16-10 Power [kW]
- 16-11 Power [hp]
- 16-12 Motor Voltage
- 16-13 Frequency
- 16-14 Motor Current
- 16-16 Torque
- 16-17 Speed [RPM]
- 16-18 Motor Thermal
- 16-30 DC Link Voltage
- 16-32 Brake Energy / s
- 16-33 Brake Energy / 2 min
- 16-34 Heatsink Temp.
- 16-35 Inverter Thermal
- 16-50 External Reference
- 16-51 Pulse Reference
- 16-52 Feedback [Unit]
- 16-60 Digital Input
- 16-62 Analog Input 53
- 16-64 Analog Input 54
- 16-65 Analog Output 42 [mA]
- 16-66 Digital Output [bin]
- 16-90 Alarm Word
- 16-92 Warning Word
- 16-94 Extended Status Word

**Function:**

Select which variables are to be logged.

**15-11 Logging Interval**

**Range:**

1 - 86400000 ms \*1ms

**Function:**

Enter the interval in milliseconds between each sampling of the variables to be logged.

**15-12 Trigger Event**

**Option:**

*False	[0]
True	[1]
Running	[2]
In range	[3]
On reference	[4]
Torque limit	[5]
Current limit	[6]
Out of current range	[7]
Below I low	[8]
Above I high	[9]
Out of speed range	[10]
Below speed low	[11]
Above speed high	[12]
Out of feedb. range	[13]
Below feedb. low	[14]
Above feedb. high	[15]

Thermal warning	[16]
Mains voltage out of range	[17]
Reversing	[18]
Warning	[19]
Alarm (trip)	[20]
Alarm (trip lock)	[21]
Comparator 0	[22]
Comparator 1	[23]
Comparator 2	[24]
Comparator 3	[25]
Logic rule 0	[26]
Logic rule 1	[27]
Logic rule 2	[28]
Logic rule 3	[29]
Digital input DI18	[33]
Digital input DI19	[34]
Digital input DI27	[35]
Digital input DI29 (FC 302 only)	[36]
Digital input DI32	[37]
Digital input DI33	[38]

**Function:**

Select the trigger event. When the trigger event occurs, a window is applied to freeze the log. The log will then retain a specified percentage of samples before the occurrence of the trigger event (par. 15-14).

**15-13 Logging Mode**

**Option:**

*Log always	[0]
Log once on trigger	[1]

**Function:**

Select *Log always* [0] for continuous logging. Select *Log once on trigger* [1] to conditionally start and stop logging using par. 15-12 and par.15-14.

**15-14 Samples Before Trigger**

**Range:**

0 - 100 N/A \*50N/A

**Function:**

Enter the percentage of all samples prior to a trigger event which are to be retained in the log. See also par. 15-12 and par. 15-13.

□ **15-2\* Historic Log**

View up to 50 logged data items via the array parameters in this parameter group. For all parameters in the group, [0] is the most recent data and [49] the oldest data. Data is logged every time an *event* occurs (not to be confused with SLC

\* default setting ( ) display text [ ] value for use in communication via serial communication port

— How to Programme —

events). *Events* in this context are defined as a change in one of the following areas:

1. Digital input
2. Digital outputs (not monitored in this SW release)
3. Warning word
4. Alarm word
5. Status word
6. Control word
7. Extended status word

*Events* are logged with value, and time stamp in msec. The time interval between two events depends on how often *events* occur (maximum once every scan time). Data logging is continuous but if an alarm occurs, the log is saved and the values can be viewed on the display. This feature is useful, for example when carrying out service following a trip. View the historic log contained in this parameter via the serial communication port or via the display.

**15-20 Historic Log: Event**

Array [50]

**Range:**

0 - 255 \* 0

**Function:**

View the event type of the logged events.

**15-21 Historic Log: Value**

Array [50]

**Range:**

0 - 2147483647 \* 0

**Function:**

View the value of the logged event. Interpret the event values according to this table:

Digital input	Decimal value. See par. 16-60 for description after converting to binary value.
Digital output (not monitored in this SW release)	Decimal value. See par. 16-66 for description after converting to binary value.
Warning word	Decimal value. See par. 16-92 for description.
Alarm word	Decimal value. See par. 16-90 for description.
Status word	Decimal value. See par. 16-03 for description after converting to binary value.
Control word	Decimal value. See par. 16-00 for description.
Extended status word	Decimal value. See par. 16-94 for description.

**15-22 Historic Log: Time**

Array [50]

**Range:**

0 - 2147483647 \* 0

**Function:**

View the time at which the logged event occurred. Time is measured in ms since frequency converter start.

□ **15-3\* Fault Log**

Parameters in this group are array parameters, where up to 10 fault logs can be viewed. [0] is the most recent logged data, and [9] the oldest. Error codes, values, and time stamp can be viewed for all logged data.

**15-30 Fault Log: Error Code**

Array [10]

**Range:**

0 - 255 \* 0

**Function:**

View the error code and look up its meaning in the *Troubleshooting* chapter of the FC 300 Design Guide.

**15-31 Fault Log: Value**

Array [10]

**Range:**

-32767 - 32767 \* 0

\* default setting ( ) display text [ ] value for use in communication via serial communication port

**Function:**

View an extra description of the error. This parameter is mostly used in combination with alarm 38 'internal fault'.

**15-32 Fault Log: Time**

Array [10]

**Range:**

0 - 2147483647 \*<sub>0</sub>

**Function:**

View the time when the logged event occurred. Time is measured in seconds from frequency converter start-up.

□ **15-4\* Drive Identification**

Parameters containing read only information about the hardware and software configuration of the frequency converter.

**15-40 FC Type**

**Function:**

View the FC type. The read-out is identical to the FC 300 Series power field of the type code definition, characters 1-6.

**15-41 Power Section**

**Function:**

View the FC type. The read-out is identical to the FC 300 Series power field of the type code definition, characters 7-10.

**15-42 Voltage**

**Function:**

View the FC type. The read-out is identical to the FC 300 Series power field of the type code definition, characters 11-12.

**15-43 Software Version**

**Function:**

View the combined SW version (or 'package version') consisting of power SW and control SW.

**15-44 Ordered Typecode String**

**Function:**

View the type code string used for re-ordering the frequency converter in its original configuration.

**15-45 Actual Typecode String**

**Function:**

View the actual type code string.

**15-46 Frequency Converter Ordering No**

**Function:**

View the 8-digit ordering number used for re-ordering the frequency converter in its original configuration.

**15-47 Power Card Ordering No**

**Function:**

View the power card ordering number.

**15-48 LCP Id No**

**Function:**

View the LCP ID number.

**15-49 SW ID Control Card**

**Function:**

View the control card software version number.

**15-50 SW ID Power Card**

**Function:**

View the power card software version number.

**15-51 Frequency Converter Serial Number**

**Function:**

View the frequency converter serial number.

**15-53 Power Card Serial Number**

**Function:**

View the power card serial number.

□ **15-6\* Option Ident.**

This read-only parameter group contains information about the hardware and software configuration of the options installed in slots A, B C0 and C1.

**15-60 Option Mounted**

**Function:**

View the installed option type.

**15-61 Option SW Version**

**Function:**

View the installed option software version.

\* default setting ( ) display text [ ] \* for use in communication via serial communication port

## — How to Programme —

**15-62 Option Ordering No****Function:**

Shows the ordering number for the installed options.

**15-63 Option Serial No****Function:**

View the installed option serial number.

**15-70 Option in Slot A****Function:**

View the type code string for the option installed in slot A, and a translation of the type code string. E.g. for type code string 'AX' the translation is 'No option'.

**15-71 Slot A Option SW Version****Function:**

View the software version for the option installed in slot A.

**15-72 Option in Slot B****Function:**

View the type code string for the option installed in slot B, and a translation of the type code string. E.g. for type code string 'BX' the translation is 'No option'.

**15-73 Slot B Option SW Version****Function:**

View the software version for the option installed in slot B.

**15-74 Option in Slot C****Function:**

View the type code string for the option installed in slot C, and a translation of the type code string. E.g. for type code string 'CXXXX' the translation is 'No option'.

**15-75 Slot C Option SW Version****Function:**

View the software version for the option installed in slot C.

□ **15-9\* Parameter Info**

Parameter lists

**15-92 Defined Parameters**

Array [1000]

**Range:**

0 - 9999 \*0

**Function:**

View a list of all defined parameters in the frequency converter. The list ends with 0.

**15-93 Modified Parameters**

Array [1000]

**Range:**

0 - 9999 \*0

**Function:**

View a list of the parameters that have been changed from their default setting. The list ends with 0. Changes may not be visible until up to 30 seconds after implementation.

**15-99 Parameter Metadata**

Array [23]

**Option:**

0 - 9999 \*0

**Function:**

This parameter contains data used by the MCT10 software tool.

\* default setting ( ) display text [ ] value for use in communication via serial communication port



□ **Parameters: Data Read-outs**

□ **16-\*\* Data Read-outs**

Parameter group for data read-outs, e.g. actual references, voltages, control, alarm, warning and status words.

□ **16-0\* General Status**

Parameters for reading the general status, e.g. the calculated reference, the active control word, status.

**16-00 Control Word**

**Range:**

0 - FFFF \*0

**Function:**

View the Control word sent from the frequency converter via the serial communication port in hex code.

**16-01 Reference [Unit]**

**Range:**

-999999.000 - 999999.000 \*0.000

**Function:**

View the present reference value applied on impulse or analog basis in the unit resulting from the configuration selected in par. 1-00 (Hz, Nm or RPM).

**16-02 Reference %**

**Range:**

-200.0 - 200.0 % \*0.0%

**Function:**

View the total reference. The total reference is the sum of digital, analog, preset, bus, and freeze references, plus catch-up and slow-down.

**16-03 Status Word**

**Range:**

0 - FFFF \*0

**Function:**

View the Status word sent from the frequency converter via the serial communication port in hex code.

**16-05 Main Actual Value [%]**

**Option:**

0 - 0 N/A \*N/A

**Function:**

View the two-byte word sent with the Status word to the bus Master reporting the Main Actual Value. Please refer to the VLT® AutomationDrive FC

\* default setting ( ) display text [ ] value for use in communication via serial communication port

300 Profibus Operating Instructions MG.33.CX.YY for a detailed description.

□ **16-1\* Motor Status**

Parameters for reading the motor status values.

**16-10 Power [kW]**

**Range:**

0.0 - 1000.0 kW \*0.0kW

**Function:**

View the motor power in kW. The value shown is calculated on the basis of the actual motor voltage and motor current. The value is filtered, and therefore approx. 1.3 seconds may pass from when an input value changes to when the data read-out values change.

**16-11 Power [hp]**

**Range:**

0.00 - 1000.00 hp \*0.00hp

**Function:**

View the motor power in hp. The value shown is calculated on the basis of the actual motor voltage and motor current. The value is filtered, and therefore approx. 1.3 seconds may pass from when an input value changes to when the data read-out values change.

**16-12 Motor Voltage**

**Range:**

0.0 - 6000.0 V \*0.0V

**Function:**

View the motor voltage, a calculated value used for controlling the motor.

**16-13 Frequency**

**Range:**

0.0 - 6500.0 Hz \*0.0Hz

**Function:**

View the motor frequency, without resonance dampening.

**16-14 Motor Current**

**Range:**

0.00 - 0.00 A \*0.00A

**Function:**

View the motor current measured as a mean value, IRMS. The value is filtered, and thus approx. 1.3 seconds may pass from when an input value changes to when the data read-out values change.

— How to Programme —

**16-15 Frequency [%]**

**Range:**  
0.00 - 0.00 % \*0.00%

**Function:**  
View a two-byte word reporting the actual motor frequency (without resonance dampening) as a percentage (scale 0000-4000 Hex) of par. 4-19 *Max. Output Frequency*. Set par. 9-16 index 1 to send it with the Status Word instead of the MAV.

**16-16 Torque**

**Range:**  
-3000.0 - 3000.0 Nm \*0.0Nm

**Function:**  
View the torque value with sign, applied to the motor shaft. Linearity is not exact between 160% motor current and torque in relation to the rated torque. Some motors supply more than 160% torque. Consequently, the min. value and the max. value will depend on the max. motor current as well as the motor used. The value is filtered, and thus approx. 1.3 seconds may pass from when an input changes value to when the data read-out values change.

**16-17 Speed [RPM]**

**Range:**  
0 - 0 RPM \*0 RPM

**Function:**  
View the actual motor RPM. In open loop or closed loop process control the motor RPM is estimated. In speed closed loop modes the motor RPM is measured.

**16-18 Motor Thermal**

**Range:**  
0 - 100 % \*0 %

**Function:**  
View the calculated thermal load on the motor. The cut-out limit is 100%. The basis for calculation is the ETR function selected in par.1-90.

**16-19 KTY Sensor Temperature**

**Range:**  
0 - xxx °C \*0°C

**Function:**  
Returning the actual temperature on KTY sensor build in the motor.

**16-20 Motor Angle**

**Range:**  
0 - 65535 \*0

**Function:**  
View the current encoder/resolver angle offset relative to the index position. The value range of 0-65535 corresponds to 0-2\*pi (radians).

- **16-3\* Drive Status**  
Parameters for reporting the status of the frequency converter.

**16-30 DC Link Voltage**

**Range:**  
0 - 10000 V \*0V

**Function:**  
View a measured value. The value is filtered, and thus approx. 1.3 seconds may pass from when an input value changes to when the data read-out value changes.

**16-32 Brake Energy /s**

**Range:**  
0.000 - 0.000 kW \*0.000kW

**Function:**  
View the brake power transmitted to an external brake resistor, stated as an instantaneous value.

**16-33 Brake Energy /2 min**

**Range:**  
0.000 - 500.000 kW \*0.000kW

**Function:**  
View the brake power transmitted to an external brake resistor. The mean power is calculated on an average basis for the most recent 120 seconds.

**16-34 Heatsink Temp.**

**Range:**  
0 - 255 °C \*0°C

**Function:**  
View the frequency converter heatsink temperature. The cut-out limit is 90 ± 5 °C, and the motor cuts back in at 60 ± 5 °C.

**16-35 Inverter Thermal**

**Range:**  
0 - 0 % \*0 %

\* default setting ( ) display text [ ] value for use in communication via serial communication port

— How to Programme —

**Function:**

View the percentage load on the inverter.

**16-36 Inv. Nom. Current**

**Range:**

0.01 - 10000.00 A \* A

**Function:**

View the inverter nominal current, which should match the nameplate data on the connected motor. The data are used for calculation of torque, motor protection, etc.

**16-37 Inv. Max. Current**

**Range:**

0.01 - 10000.00 A \*A

**Function:**

View the inverter maximum current, which should match the nameplate data on the connected motor. The data are used for calculation of torque, motor protection, etc.

**16-38 SL Controller State**

**Range:**

0 - 0 \*0

**Function:**

View the state of the event under execution by the SL controller.

**16-39 Control Card Temp.**

**Range:**

0 - 100 °C \*0°C

**Function:**

View the temperature on the control card, stated in °C.

**16-40 Logging Buffer Full**

**Option:**

\*No [0]  
Yes [1]

**Function:**

View whether the logging buffer is full (see par. 15-1\*). The logging buffer will never be full when par. 15-13 *Logging Mode* is set to *Log always* [0].

□ **16-5\* Ref. & Feedb.**

Parameters for reporting the reference and feedback input.

**16-50 External Reference**

**Range:**

0.0 - 0.0 \*0.0

**Function:**

View the total reference, the sum of digital, analog, preset, bus and freeze references, plus catch-up and slow-down.

**16-51 Pulse Reference**

**Range:**

0.0 - 0.0 \*0.0

**Function:**

View the reference value from programmed digital input(s). The read-out can also reflect the impulses from an incremental encoder.

**16-52 Feedback [Unit]**

**Range:**

0.0 - 0.0 \*0.0

**Function:**

View the feedback unit resulting from the selection of unit and scaling in par. 3-00, 3-01, 3-02 and 3-03.

**16-53 Digi Pot Reference**

**Range:**

0.0 - 0.0 \*0.0

**Function:**

View the contribution of the Digital Potentiometer to the actual reference.

□ **16-6\* Inputs and Outputs**

Parameters for reporting the digital and analog IO ports.

**16-60 Digital Input**

**Range:**

0 - 63 \*0

**Function:**

View the signal states from the active digital inputs. Input 18 corresponds to the bit at the far left. '0' = no signal, '1' = connected signal.

\* default setting ( ) display text [ ] value for use in communication via serial communication port

— How to Programme —

Bit 0	Digital input term. 33
Bit 1	Digital input term. 32
Bit 2	Digital input term. 29
Bit 3	Digital input term. 27
Bit 4	Digital input term. 19
Bit 5	Digital input term. 18
Bit 6	Digital input term. 37
Bit 7	Digital input GP I/O term. X30/2
Bit 8	Digital input GP I/O term. X30/3
Bit 9	Digital input GP I/O term. X30/4
Bit 10-63	Reserved for future terminals

**16-61 Terminal 53 Switch Setting**

**Option:**

- \*Current [0]
- Voltage [1]

**Function:**

View the setting of input terminal 53.  
Current = 0; Voltage = 1.

**16-62 Analog Input 53**

**Range:**

0.000 - 0.000 \*0.000

**Function:**

View the actual value at input 53 either as a reference or a protection value.

**16-63 Terminal 54 Switch Setting**

**Option:**

- \*Current [0]
- Voltage [1]

**Function:**

View the setting of input terminal 54.  
Current = 0; Voltage = 1.

**16-64 Analog Input 54**

**Range:**

0.000 - 0.000 \*0.000

**Function:**

View the actual value at input 54 either as a reference or a protection value.

**16-65 Analog Output 42 [mA]**

**Range:**

0.000 - 0.000 \*0.000

**Function:**

View the actual value at output 42 in mA. The value shown reflects the selection in par. 06-50.

**16-66 Digital Output [bin]**

**Range:**

0 - 3 \*0

**Function:**

View the binary value of all digital outputs.

**16-67 Freq. Input #29 [Hz]**

**Range:**

0 - 0 \*0

**Function:**

View the actual frequency rate on terminal 29.  
This parameter is available for FC 302 only.

**16-68 Freq. Input #33 [Hz]**

**Range:**

0 - 0 \*0

**Function:**

View the actual value of the frequency applied at terminal 29 as an impulse input.

**16-69 Pulse Output #27 [Hz]**

**Range:**

0 - 0 \*0

**Function:**

View the actual value of impulses applied to terminal 27 in digital output mode.

**16-70 Pulse Output #29 [Hz]**

**Range:**

0 - 0 \*0

**Function:**

View the actual value of pulses to terminal 29 in digital output mode.  
This parameter is available for FC 302 only.

**16-71 Relay Output [bin]**

**Range:**

0 - 31 \*0

**Function:**

View the settings of all relays.

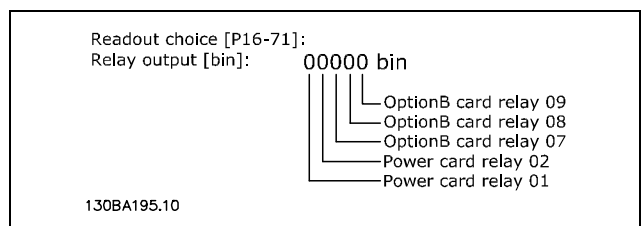

\* default setting ( ) display text [ ] value for use in communication via serial communication port

— How to Programme —

**16-72 Counter A**

**Range:**

0 - 0 \*0

**Function:**

View the present value of Counter A. Counters are useful as comparator operands, see par. 13-10. The value can be reset or changed either via digital inputs (parameter group 5-1\*) or by using an SLC action (par. 13-52).

**16-73 Counter B**

**Range:**

0 - 0 \*0

**Function:**

View the present value of Counter B. Counters are useful as comparator operands (par. 13-10). The value can be reset or changed either via digital inputs (parameter group 5-1\*) or by using an SLC action (par. 13-52).

**16-74 Precise Stop Counter**

**Range:**

-2147483648 - 2147483648 \*0

**Function:**

Returns the actual counter value of precise counter (par. 1-84).

□ **16-8\* Fieldbus & FC Port**

Parameters for reporting the BUS references and control words.

**16-80 Fieldbus CTW 1**

**Range:**

0 - 65535 \*0

**Function:**

View the two-byte Control word (CTW) received from the Bus-Master. Interpretation of the Control word depends on the fieldbus option installed and the Control word profile selected in par. 8-10. For more information please refer to the relevant fieldbus manual.

**16-82 Fieldbus REF 1**

**Function:**

View the two-byte word sent with the control word form the Bus-Master to set the reference value. For more information please refer to the relevant fieldbus manual.

**16-84 Comm. Option STW**

**Range:**

0 - 65535 \*0

**Function:**

View the extended fieldbus comm. option status word. For more information please refer to the relevant fieldbus manual.

**16-85 FC Port CTW 1**

**Range:**

0 - 65535 \*0

**Function:**

View the two-byte Control word (CTW) received from the Bus-Master. Interpretation of the control word depends on the fieldbus option installed and the Control word profile selected in par. 8-10.

**16-86 FC Port REF 1**

**Range:**

0 - 0 \*0

**Function:**

View the two-byte Status word (STW) sent to the Bus-Master. Interpretation of the Status word depends on the fieldbus option installed and the Control word profile selected in par. 8-10.

□ **16-9\* Diagnosis Read-Out**

Parameters displaying alarm, warning and extended status words.

**16-90 Alarm Word**

**Range:**

0 - FFFF \*0

**Function:**

View the alarm word sent via the serial communication port in hex code.

\* default setting ( ) display text [ ] value for use in communication via serial communication port

**16-92 Warning Word****Range:**

0 - FFFF \*0

**Function:**

View the warning word sent via the serial communication port in hex code.

**16-94 Ext. Status Word****Range:**

0 - FFFF \*0

**Function:**

Returns the extended warning word sent via the serial communication port in hex code.

□ **Parameters: EncoderInput**

□ **17-\*\* Motor Feedb. Option**

Additional parameters to configure the Encoder (MCB102) or the Resolver (MCB103) Feedback Option.

□ **17-1\* Inc. Enc. Interface**

Parameters in this group configure the incremental interface of the MCB102 option. Note that both the incremental and absolute interfaces are active at the same time.

**17-10 Signal Type**

Option:	
None	[0]
*RS422 (5V TTL/linedrv.)	[1]
Sinusoidal 1Vpp	[2]

**Function:**

Select the incremental type (A/B channel) of the encoder in use. Find the information on the encoder data sheet. Select *None* [0] if the feedback sensor is an absolute encoder only. This parameter cannot be adjusted while the motor is running.

**17-11 Resolution (PPR)**

Range:	
10 - 10000	*1024

**Function:**

Enter the resolution of the incremental track, i.e. the number of pulses or periods per revolution. This parameter cannot be adjusted while the motor is running.

□ **17-2\* Abs. Enc. Interface**

Parameters in this group configure the absolute interface of the MCB102 option. Note that both the incremental and absolute interfaces are active at the same time.

**17-20 Protocol Selection**

Option:	
*None	[0]
HIPERFACE	[1]
EnDat	[2]
SSI	[4]

**Function:**

Select *HIPERFACE* [1] if the encoder is absolute only. Select *None* [0] if the feedback sensor is an incremental encoder only.

\* default setting ( ) display text [ ] value for use in communication via serial communication port

This parameter cannot be adjusted while the motor is running.

**17-21 Resolution (Positions/Rev)**

Option:	
512	[512]
1024	[1024]
2048	[2048]
4096	[4096]
*SSI 4 - 8192	[8192]
16384	[16384]
*HIPERFACE 512 - 32768	[32768]

**Function:**

Select the resolution of the absolute encoder, i.e. the number of counts per revolution. This parameter cannot be adjusted while the motor is running.

**17-24 SSI Data Length**

Range:	
13 - 25	*13

**Function:**

Set the number of bits for the SSI telegram. Choose 13 bits for single-turn encoders and 25 bits for multi-turn encoder.

**17-25 Clock Rate**

Range:	
100 - 260 kHz	*260kHz

**Function:**

Set the SSI clock rate. By long encoder cables the clock rate must be reduced.

**17-26 SSI Data Format**

Option:	
*Gray Code	[0]
Binary Code	[1]

**Function:**

Set the data format of the SSI data. Choose between Gray or Binary format.

**17-34 HIPERFACE Baudrate**

Option:	
600	[0]
1200	[1]
2400	[2]
4800	[3]
*9600	[4]
19200	[5]
38400	[6]

— How to Programme —

**Function:**

Select the baud rate of the attached encoder. This parameter cannot be adjusted while the motor is running.

□ **17-5\* Resolver Interface**

Parameter group 17-5\* is used for setting parameters for the MCB 103 Resolver Option. Usually the resolver feedback is used as motor feedback from Permanent Magnet motors with par. 1-01 set to Flux with motor feedback. Resolver parameters cannot be adjusted while the motor is running.

**17-51 Resolver Input Voltage**

**Range:**

4.0 - 8.0 V \*7.0V

**Function:**

Set the input voltage to the resolver. The voltage is stated as RMS value. The value is stated in the data sheet for resolvers

**17-50 Resolver Poles**

**Range:**

2-4 \*2

**Function:**

Set the number of poles on the resolver. Most resolvers have 2 poles. The value is stated in the data sheet for resolvers.

**17-52 Resolver Input Frequency**

**Range:**

2.0 - 15.0 kHz \*10.0kHz

**Function:**

Set the input frequency to the resolver. The value is stated in the data sheet for resolvers.

**17-53 Resolver Transformation Ratio**

**Range:**

0.1 - 1.1 \*0.5

**Function:**

Set the transformation ratio for the resolver. The transformation ration is:

$$T_{ratio} = \frac{V_{Out}}{V_{In}}$$

The value is stated in the data sheet for resolvers.

**17-59 Resolver Interface**

**Option:**

*False	[0]
True	[1]

**Function:**

Activate the MCB 103 resolver option when the resolver parameters are selected. To avoid damage of resolvers par. 17-50 – par. 17-53 must be adjusted before activating this parameter.

□ **17-6\* Monitoring and Application**

This parameter group is selecting additional functions when MCB 102 Encoder option or MCB 103 Resolver option is fitted into option slot B as speed feedback. Monitoring and Application parameters cannot be adjusted while the motor is running.

**17-60 Encoder Positive Direction**

**Option:**

*Clockwise	[0]
Counter clockwise	[1]

**Function:**

Change the detected encoder rotation direction without changing the wiring to the encoder. This parameter cannot be adjusted while the motor is running.

**17-61 Encoder Signal Monitoring**

**Option:**

Disabled	[0]
*Warning	[1]
Trip	[2]

**Function:**

Select which reaction the frequency converter should take in case a fault encoder signal is detected. The encoder function in par. 17-61 is an electrical check of the hardware circuit in the encoder system.

\* default setting ( ) display text [ ] value for use in communication via serial communication port



## □ Parameter Lists

### FC Series

All = valid for FC 301 and FC 302 series

01 = valid for FC 301 only

02 = valid for FC 302 only

### Changes during operation

“TRUE” means that the parameter can be changed while the frequency converter is in operation and

“FALSE” means that the frequency converter must be stopped before a change can be made.

### 4-Set-up

‘All set-up’: the parameter can be set individually in each of the four set-ups, i. e. one single parameter can have four different data values.

‘1 set-up’: data value will be the same in all set-ups.

### Conversion index

This number refers to a conversion figure used when writing or reading by means of a frequency converter.

Conv. index	100	67	6	5	4	3	2	1	0	-1	-2	-3	-4	-5	-6
Conv. factor	1	1/60	1000000	100000	10000	1000	100	10	1	0.1	0.01	0.001	0.0001	0.00001	0.000001

Data type	Description	Type
2	Integer 8	Int8
3	Integer 16	Int16
4	Integer 32	Int32
5	Unsigned 8	UInt8
6	Unsigned 16	UInt16
7	Unsigned 32	UInt32
9	Visible String	VisStr
33	Normalized value 2 bytes	N2
35	Bit sequence of 16 boolean variables	V2
54	Time difference w/o date	TimD

\* default setting ( ) display text [ ] \* for use in communication via serial communication port

— How to Programme —

□ **0-\*\* Operation/Display**

Par. No. #	Parameter description	Default value	4-set-up	FC 302 only	Change during operation	Conversion index	Type
<b>0-0* Basic Settings</b>							
0-01	Language	[0] English	1 set-up		TRUE	-	Uint8
0-02	Motor Speed Unit	[0] RPM	2 set-ups		FALSE	-	Uint8
0-03	Regional Settings	[0] International	2 set-ups		FALSE	-	Uint8
0-04	Operating State at Power-up (Hand)	[1] Forced stop, ref=old	All set-ups		TRUE	-	Uint8
<b>0-1* Set-up Handling</b>							
0-10	Active Set-up	[1] Setup 1	1 set-up		TRUE	-	Uint8
0-11	Edit Set-up	[1] Setup 1	All set-ups		TRUE	-	Uint8
0-12	This Set-up Linked to	[0] Not linked	All set-ups		FALSE	-	Uint8
0-13	Readout: Linked Set-ups	0 N/A	All set-ups		FALSE	0	Uint16
0-14	Readout: Edit Set-ups / Channel	0 N/A	All set-ups		TRUE	0	Int32
<b>0-2* LCP Display</b>							
0-20	Display Line 1.1 Small	1617	All set-ups		TRUE	-	Uint16
0-21	Display Line 1.2 Small	1614	All set-ups		TRUE	-	Uint16
0-22	Display Line 1.3 Small	1610	All set-ups		TRUE	-	Uint16
0-23	Display Line 2 Large	1613	All set-ups		TRUE	-	Uint16
0-24	Display Line 3 Large	1602	All set-ups		TRUE	-	Uint16
0-25	My Personal Menu	ExpressionLimit	1 set-up		TRUE	0	Uint16
<b>0-3* LCP Custom Readout</b>							
0-30	Unit for User-defined Readout	[0] None 0.00 CustomRead-	All set-ups		TRUE	-	Uint8
0-31	Min Value of User-defined Readout	outUnit 100.00 CustomRead-	All set-ups		TRUE	-2	Int32
0-32	Max Value of User-defined Readout	outUnit	All set-ups		TRUE	-2	Int32
<b>0-4* LCP Keypad</b>							
0-40	[Hand on] Key on LCP	[1] Enabled	All set-ups		TRUE	-	Uint8
0-41	[Off] Key on LCP	[1] Enabled	All set-ups		TRUE	-	Uint8
0-42	[Auto on] Key on LCP	[1] Enabled	All set-ups		TRUE	-	Uint8
0-43	[Reset] Key on LCP	[1] Enabled	All set-ups		TRUE	-	Uint8
<b>0-5* Copy/Save</b>							
0-50	LCP Copy	[0] No copy	All set-ups		FALSE	-	Uint8
0-51	Set-up Copy	[0] No copy	All set-ups		FALSE	-	Uint8
<b>0-6* Password</b>							
0-60	Main Menu Password	100 N/A	1 set-up		TRUE	0	Uint16
0-61	Access to Main Menu w/o Password	[0] Full access	1 set-up		TRUE	-	Uint8
0-65	Quick Menu Password	200 N/A	1 set-up		TRUE	0	Uint16
0-66	Access to Quick Menu w/o Password	[0] Full access	1 set-up		TRUE	-	Uint8

\* default setting ( ) display text [ ] value for use in communication via serial communication port

— How to Programme —

□ 1-\*\* Load/Motor

Par. No. #	Parameter description	Default value	4-set-up	FC 302 only	Change during operation	Conversion index	Type
<b>1-0* General Settings</b>							
1-00	Configuration Mode	null	All set-ups		TRUE	-	Uint8
1-01	Motor Control Principle	null	All set-ups		FALSE	-	Uint8
1-02	Flux Motor Feedback Source	[1] 24V encoder	All set-ups	x	FALSE	-	Uint8
1-03	Torque Characteristics	[0] Constant torque	All set-ups		TRUE	-	Uint8
1-04	Overload Mode	[0] High torque [2] As conf. mode	All set-ups		FALSE	-	Uint8
1-05	Local Mode Configuration	P.1-00	All set-ups		TRUE	-	Uint8
<b>1-1* Motor Selection</b>							
1-10	Motor Construction	[0] Asynchron	All set-ups		FALSE	-	Uint8
<b>1-2* Motor Data</b>							
1-20	Motor Power [kW]	ExpressionLimit	All set-ups		FALSE	1	Uint32
1-21	Motor Power [HP]	ExpressionLimit	All set-ups		FALSE	-2	Uint32
1-22	Motor Voltage	ExpressionLimit	All set-ups		FALSE	0	Uint16
1-23	Motor Frequency	ExpressionLimit	All set-ups		FALSE	0	Uint16
1-24	Motor Current	ExpressionLimit	All set-ups		FALSE	-2	Uint32
1-25	Motor Nominal Speed	ExpressionLimit	All set-ups		FALSE	67	Uint16
1-26	Motor Cont. Rated Torque	ExpressionLimit	All set-ups		FALSE	-1	Uint32
1-29	Automatic Motor Adaptation (AMA)	[0] Off	All set-ups		FALSE	-	Uint8
<b>1-3* Adv. Motor Data</b>							
1-30	Stator Resistance (Rs)	ExpressionLimit	All set-ups		FALSE	-4	Uint32
1-31	Rotor Resistance (Rr)	ExpressionLimit	All set-ups		FALSE	-4	Uint32
1-33	Stator Leakage Reactance (X1)	ExpressionLimit	All set-ups		FALSE	-4	Uint32
1-34	Rotor Leakage Reactance (X2)	ExpressionLimit	All set-ups		FALSE	-4	Uint32
1-35	Main Reactance (Xh)	ExpressionLimit	All set-ups		FALSE	-4	Uint32
1-36	Iron Loss Resistance (Rfe)	ExpressionLimit	All set-ups		FALSE	-3	Uint32
1-37	d-axis Inductance (Ld)	ExpressionLimit	All set-ups	x	FALSE	-4	Int32
1-39	Motor Poles	ExpressionLimit	All set-ups		FALSE	0	Uint8
1-40	Back EMF at 1000 RPM	ExpressionLimit	All set-ups	x	FALSE	0	Uint16
1-41	Motor Angle Offset	0 N/A	All set-ups		FALSE	0	Int16
<b>1-5* Load Indep. Setting</b>							
1-50	Motor Magnetisation at Zero Speed Min Speed Normal Magnetising	100 %	All set-ups		TRUE	0	Uint16
1-51	[RPM]	ExpressionLimit	All set-ups		TRUE	67	Uint16
1-52	Min Speed Normal Magnetising [Hz]	ExpressionLimit	All set-ups		TRUE	-1	Uint16
1-53	Model Shift Frequency	ExpressionLimit	All set-ups	x	FALSE	-1	Uint16
1-55	U/f Characteristic - U	ExpressionLimit	All set-ups		TRUE	-1	Uint16
1-56	U/f Characteristic - F	ExpressionLimit	All set-ups		TRUE	-1	Uint16
<b>1-6* Load Depen. Setting</b>							
1-60	Low Speed Load Compensation	100 %	All set-ups		TRUE	0	Int16
1-61	High Speed Load Compensation	100 %	All set-ups		TRUE	0	Int16
1-62	Slip Compensation	ExpressionLimit	All set-ups		TRUE	0	Int16
1-63	Slip Compensation Time Constant	0.10 s	All set-ups		TRUE	-2	Uint16
1-64	Resonance Dampening Resonance Dampening Time	100 %	All set-ups		TRUE	0	Uint16
1-65	Constant	5 ms	All set-ups		TRUE	-3	Uint8
1-66	Min. Current at Low Speed	100 %	All set-ups	x	TRUE	0	Uint8
1-67	Load Type	[0] Passive load	All set-ups	x	TRUE	-	Uint8
1-68	Minimum Inertia	ExpressionLimit	All set-ups	x	FALSE	-4	Uint32
1-69	Maximum Inertia	ExpressionLimit	All set-ups	x	FALSE	-4	Uint32
<b>1-7* Start Adjustments</b>							
1-71	Start Delay	0.0 s	All set-ups		TRUE	-1	Uint8
1-72	Start Function	[2] Coast/delay time	All set-ups		TRUE	-	Uint8
1-73	Flying Start	[0] Disabled	All set-ups		FALSE	-	Uint8
1-74	Start Speed [RPM]	ExpressionLimit	All set-ups		TRUE	67	Uint16
1-75	Start Speed [Hz]	ExpressionLimit	All set-ups		TRUE	-1	Uint16
1-76	Start Current	0.00 A	All set-ups		TRUE	-2	Uint32

\* default setting ( ) display text [ ] value for use in communication via serial communication port

— How to Programme —

Par. No. #	Parameter description	Default value	4-set-up	FC 302 only	Change during operation	Conversion index	Type
<b>1-8* Stop Adjustments</b>							
1-80	Function at Stop Min Speed for Function at Stop	[0] Coast	All set-ups		TRUE	-	Uint8
1-81	[RPM]	ExpressionLimit	All set-ups		TRUE	67	Uint16
1-82	Min Speed for Function at Stop [Hz]	ExpressionLimit	All set-ups		TRUE	-1	Uint16
1-83	Precise Stop Function	[0] Precise ramp stop	All set-ups		FALSE	-	Uint8
1-84	Precise Stop Counter Value	100000 N/A	All set-ups		TRUE	0	Uint32
1-85	Precise Stop Speed Comp. Delay	10 ms	All set-ups		TRUE	-3	Uint8
<b>1-9* Motor Temperature</b>							
1-90	Motor Thermal Protection	[0] No protection	All set-ups		TRUE	-	Uint8
1-91	Motor External Fan	[0] No	All set-ups		TRUE	-	Uint16
1-93	Thermistor Resource	[0] None	All set-ups		TRUE	-	Uint8
1-95	KTY Sensor Type	[0] KTY Sensor 1	All set-ups		TRUE	-	Uint8
1-96	KTY Thermistor Resource	[0] None	All set-ups		TRUE	-	Uint8
1-97	KTY Threshold level	80 °C	1 set-up		TRUE	100	Int16

\* default setting ( ) display text [ ] value for use in communication via serial communication port

— How to Programme —

□ **2-\*\*\* Brakes**

Par. No. #	Parameter description	Default value	4-set-up	FC 302 only	Change during operation	Conversion index	Type
<b>2-0* DC-Brake</b>							
2-00	DC Hold Current	50 %	All set-ups		TRUE	0	Uint8
2-01	DC Brake Current	50 %	All set-ups		TRUE	0	Uint16
2-02	DC Braking Time	10.0 s	All set-ups		TRUE	-1	Uint16
2-03	DC Brake Cut In Speed [RPM]	ExpressionLimit	All set-ups		TRUE	67	Uint16
2-04	DC Brake Cut In Speed [Hz]	ExpressionLimit	All set-ups		TRUE	-1	Uint16
<b>2-1* Brake Energy Funct.</b>							
2-10	Brake Function	null	All set-ups		TRUE	-	Uint8
2-11	Brake Resistor (ohm)	ExpressionLimit	All set-ups		TRUE	0	Uint16
2-12	Brake Power Limit (kW)	ExpressionLimit	All set-ups		TRUE	0	Uint32
2-13	Brake Power Monitoring	[0] Off	All set-ups		TRUE	-	Uint8
2-15	Brake Check	[0] Off	All set-ups		TRUE	-	Uint8
2-16	AC-brake Max. Current	100.0 %	All set-ups		TRUE	-1	Uint32
2-17	Over-voltage Control	[0] Disabled	All set-ups		TRUE	-	Uint8
<b>2-2* Mechanical Brake</b>							
2-20	Release Brake Current	ExpressionLimit	All set-ups		TRUE	-2	Uint32
2-21	Activate Brake Speed [RPM]	ExpressionLimit	All set-ups		TRUE	67	Uint16
2-22	Activate Brake Speed [Hz]	ExpressionLimit	All set-ups		TRUE	-1	Uint16
2-23	Activate Brake Delay	0.0 s	All set-ups		TRUE	-1	Uint8

\* default setting ( ) display text [ ] value for use in communication via serial communication port

## — How to Programme —

□ **3-\*\*\* Reference / Ramps**

Par. No. #	Parameter description	Default value	4-set-up	FC 302 only	Change during operation	Conversion index	Type
<b>3-0* Reference Limits</b>							
3-00	Reference Range	null	All set-ups		TRUE	-	Uint8
3-01	Reference/Feedback Unit	null	All set-ups		TRUE	-	Uint8
3-02	Minimum Reference	ExpressionLimit	All set-ups		TRUE	-3	Int32
3-03	Maximum Reference	ExpressionLimit	All set-ups		TRUE	-3	Int32
3-04	Reference Function	[0] Sum	All set-ups		TRUE	-	Uint8
<b>3-1* References</b>							
3-10	Preset Reference	0.00 %	All set-ups		TRUE	-2	Int16
3-11	Jog Speed [Hz]	ExpressionLimit	All set-ups		TRUE	-1	Uint16
3-12	Catch up/slow Down Value	0.00 %	All set-ups		TRUE	-2	Int16
		[0] Linked to Hand					
3-13	Reference Site	/ Auto	All set-ups		TRUE	-	Uint8
3-14	Preset Relative Reference	0.00 %	All set-ups		TRUE	-2	Int32
3-15	Reference Resource 1	null	All set-ups		TRUE	-	Uint8
3-16	Reference Resource 2	null	All set-ups		TRUE	-	Uint8
3-17	Reference Resource 3	null	All set-ups		TRUE	-	Uint8
	Relative Scaling Reference						
3-18	Resource	[0] No function	All set-ups		TRUE	-	Uint8
3-19	Jog Speed [RPM]	ExpressionLimit	All set-ups		TRUE	67	Uint16
<b>3-4* Ramp 1</b>							
3-40	Ramp 1 Type	[0] Linear	All set-ups		TRUE	-	Uint8
3-41	Ramp 1 Ramp up Time	ExpressionLimit	All set-ups		TRUE	-2	Uint32
3-42	Ramp 1 Ramp Down Time	ExpressionLimit	All set-ups		TRUE	-2	Uint32
	Ramp 1 S-ramp Ratio at Accel.						
3-45	Start	50 %	All set-ups		TRUE	0	Uint8
3-46	Ramp 1 S-ramp Ratio at Accel. End	50 %	All set-ups		TRUE	0	Uint8
	Ramp 1 S-ramp Ratio at Decel.						
3-47	Start	50 %	All set-ups		TRUE	0	Uint8
3-48	Ramp 1 S-ramp Ratio at Decel. End	50 %	All set-ups		TRUE	0	Uint8
<b>3-5* Ramp 2</b>							
3-50	Ramp 2 Type	[0] Linear	All set-ups		TRUE	-	Uint8
3-51	Ramp 2 Ramp up Time	ExpressionLimit	All set-ups		TRUE	-2	Uint32
3-52	Ramp 2 Ramp down Time	ExpressionLimit	All set-ups		TRUE	-2	Uint32
	Ramp 2 S-ramp Ratio at Accel.						
3-55	Start	50 %	All set-ups		TRUE	0	Uint8
3-56	Ramp 2 S-ramp Ratio at Accel. End	50 %	All set-ups		TRUE	0	Uint8
	Ramp 2 S-ramp Ratio at Decel.						
3-57	Start	50 %	All set-ups		TRUE	0	Uint8
3-58	Ramp 2 S-ramp Ratio at Decel. End	50 %	All set-ups		TRUE	0	Uint8
<b>3-6* Ramp 3</b>							
3-60	Ramp 3 Type	[0] Linear	All set-ups		TRUE	-	Uint8
3-61	Ramp 3 Ramp up Time	ExpressionLimit	All set-ups		TRUE	-2	Uint32
3-62	Ramp 3 Ramp down Time	ExpressionLimit	All set-ups		TRUE	-2	Uint32
	Ramp 3 S-ramp Ratio at Accel.						
3-65	Start	50 %	All set-ups		TRUE	0	Uint8
3-66	Ramp 3 S-ramp Ratio at Accel. End	50 %	All set-ups		TRUE	0	Uint8
	Ramp 3 S-ramp Ratio at Decel.						
3-67	Start	50 %	All set-ups		TRUE	0	Uint8
3-68	Ramp 3 S-ramp Ratio at Decel. End	50 %	All set-ups		TRUE	0	Uint8

\* default setting ( ) display text [ ] value for use in communication via serial communication port

## — How to Programme —

Par. No. #	Parameter description	Default value	4-set-up	FC 302 only	Change during operation	Conversion index	Type
<b>3-7* Ramp 4</b>							
3-70	Ramp 4 Type	[0] Linear	All set-ups		TRUE	-	Uint8
3-71	Ramp 4 Ramp up Time	ExpressionLimit	All set-ups		TRUE	-2	Uint32
3-72	Ramp 4 Ramp Down Time	ExpressionLimit	All set-ups		TRUE	-2	Uint32
Ramp 4 S-ramp Ratio at Accel.							
3-75	Start	50 %	All set-ups		TRUE	0	Uint8
3-76	Ramp 4 S-ramp Ratio at Accel. End	50 %	All set-ups		TRUE	0	Uint8
Ramp 4 S-ramp Ratio at Decel.							
3-77	Start	50 %	All set-ups		TRUE	0	Uint8
3-78	Ramp 4 S-ramp Ratio at Decel. End	50 %	All set-ups		TRUE	0	Uint8
<b>3-8* Other Ramps</b>							
3-80	Jog Ramp Time	ExpressionLimit	All set-ups		TRUE	-2	Uint32
3-81	Quick Stop Ramp Time	ExpressionLimit	2 set-ups		TRUE	-2	Uint32
<b>3-9* Digital Pot.Meter</b>							
3-90	Step Size	0.10 %	All set-ups		TRUE	-2	Uint16
3-91	Ramp Time	1.00 s	All set-ups		TRUE	-2	Uint32
3-92	Power Restore	[0] Off	All set-ups		TRUE	-	Uint8
3-93	Maximum Limit	100 %	All set-ups		TRUE	0	Int16
3-94	Minimum Limit	-100 %	All set-ups		TRUE	0	Int16
3-95	Ramp Delay	1.000 N/A	All set-ups		TRUE	-3	TimD

\* default setting ( ) display text [ ] value for use in communication via serial communication port

— How to Programme —

□ **4-\*\*\* Limits / Warnings**

Par. No. #	Parameter description	Default value	4-set-up	FC 302 only	Change during operation	Conversion index	Type
<b>4-1* Motor Limits</b>							
4-10	Motor Speed Direction	null	All set-ups		FALSE	-	Uint8
4-11	Motor Speed Low Limit [RPM]	ExpressionLimit	All set-ups		TRUE	67	Uint16
4-12	Motor Speed Low Limit [Hz]	ExpressionLimit	All set-ups		TRUE	-1	Uint16
4-13	Motor Speed High Limit [RPM]	ExpressionLimit	All set-ups		TRUE	67	Uint16
4-14	Motor Speed High Limit [Hz]	ExpressionLimit	All set-ups		TRUE	-1	Uint16
4-16	Torque Limit Motor Mode	160.0 %	All set-ups		TRUE	-1	Uint16
4-17	Torque Limit Generator Mode	100.0 %	All set-ups		TRUE	-1	Uint16
4-18	Current Limit	ExpressionLimit	All set-ups		TRUE	-1	Uint32
4-19	Max Output Frequency	132.0 Hz	All set-ups		FALSE	-1	Uint16
<b>4-3* Motor Fb Monitor</b>							
4-30	Motor Feedback Loss Function	[2] Trip	All set-ups		TRUE	-	Uint8
4-31	Motor Feedback Speed Error	300 RPM	All set-ups		TRUE	67	Uint16
4-32	Motor Feedback Loss Timeout	0.05 s	All set-ups		TRUE	-2	Uint16
<b>4-5* Adj. Warnings</b>							
4-50	Warning Current Low	0.00 A	All set-ups		TRUE	-2	Uint32
4-51	Warning Current High	ImaxVLT (P1637)	All set-ups		TRUE	-2	Uint32
4-52	Warning Speed Low	0 RPM	All set-ups		TRUE	67	Uint16
4-53	Warning Speed High	outputSpeedHighLimit (P413)	All set-ups		TRUE	67	Uint16
4-54	Warning Reference Low	-999999.999 N/A	All set-ups		TRUE	-3	Int32
4-55	Warning Reference High	999999.999 N/A	All set-ups		TRUE	-3	Int32
4-56	Warning Feedback Low	-999999.999 ReferenceFeedbackUnit	All set-ups		TRUE	-3	Int32
4-57	Warning Feedback High	999999.999 ReferenceFeedbackUnit	All set-ups		TRUE	-3	Int32
4-58	Missing Motor Phase Function	[1] On	All set-ups		TRUE	-	Uint8
<b>4-6* Speed Bypass</b>							
4-60	Bypass Speed From [RPM]	ExpressionLimit	All set-ups		TRUE	67	Uint16
4-61	Bypass Speed From [Hz]	ExpressionLimit	All set-ups		TRUE	-1	Uint16
4-62	Bypass Speed To [RPM]	ExpressionLimit	All set-ups		TRUE	67	Uint16
4-63	Bypass Speed To [Hz]	ExpressionLimit	All set-ups		TRUE	-1	Uint16

\* default setting ( ) display text [ ] value for use in communication via serial communication port



— How to Programme —

□ **5-\*\* Digital In/Out**

Par. No. #	Parameter description	Default value	4-set-up	FC 302 only	Change during operation	Conversion index	Type
<b>5-0* Digital I/O mode</b>							
5-00	Digital I/O Mode	[0] PNP	All set-ups		FALSE	-	Uint8
5-01	Terminal 27 Mode	[0] Input	All set-ups		TRUE	-	Uint8
5-02	Terminal 29 Mode	[0] Input	All set-ups	x	TRUE	-	Uint8
<b>5-1* Digital Inputs</b>							
5-10	Terminal 18 Digital Input	null	All set-ups		TRUE	-	Uint8
5-11	Terminal 19 Digital Input	null	All set-ups		TRUE	-	Uint8
5-12	Terminal 27 Digital Input	null	All set-ups		TRUE	-	Uint8
5-13	Terminal 29 Digital Input	null	All set-ups	x	TRUE	-	Uint8
5-14	Terminal 32 Digital Input	[0] No operation	All set-ups		TRUE	-	Uint8
5-15	Terminal 33 Digital Input	[0] No operation	All set-ups		TRUE	-	Uint8
5-16	Terminal X30/2 Digital Input	[0] No operation	All set-ups		TRUE	-	Uint8
5-17	Terminal X30/3 Digital Input	[0] No operation	All set-ups		TRUE	-	Uint8
5-18	Terminal X30/4 Digital Input	[0] No operation	All set-ups		TRUE	-	Uint8
<b>5-3* Digital Outputs</b>							
5-30	Terminal 27 Digital Output	null	All set-ups		TRUE	-	Uint8
5-31	Terminal 29 Digital Output	null	All set-ups	x	TRUE	-	Uint8
5-32	Terminal X30/6 Digital Output	null	All set-ups		TRUE	-	Uint8
5-33	Terminal X30/7 Digital Output	null	All set-ups		TRUE	-	Uint8
<b>5-4* Relays</b>							
5-40	Function Relay	null	All set-ups		TRUE	-	Uint8
5-41	On Delay, Relay	0.01 s	All set-ups		TRUE	-2	Uint16
5-42	Off Delay, Relay	0.01 s	All set-ups		TRUE	-2	Uint16
<b>5-5* Pulse Input</b>							
5-50	Term. 29 Low Frequency	100 Hz	All set-ups	x	TRUE	0	Uint32
5-51	Term. 29 High Frequency	100 Hz	All set-ups	x	TRUE	0	Uint32
		0.000 Reference-					
5-52	Term. 29 Low Ref./Feedb. Value	FeedbackUnit	All set-ups	x	TRUE	-3	Int32
5-53	Term. 29 High Ref./Feedb. Value	ExpressionLimit	All set-ups	x	TRUE	-3	Int32
5-54	Pulse Filter Time Constant #29	100 ms	All set-ups	x	FALSE	-3	Uint16
5-55	Term. 33 Low Frequency	100 Hz	All set-ups		TRUE	0	Uint32
5-56	Term. 33 High Frequency	100 Hz	All set-ups		TRUE	0	Uint32
		0.000 Reference-					
5-57	Term. 33 Low Ref./Feedb. Value	FeedbackUnit	All set-ups		TRUE	-3	Int32
5-58	Term. 33 High Ref./Feedb. Value	ExpressionLimit	All set-ups		TRUE	-3	Int32
5-59	Pulse Filter Time Constant #33	100 ms	All set-ups		FALSE	-3	Uint16
<b>5-6* Pulse Output</b>							
5-60	Terminal 27 Pulse Output Variable	null	All set-ups		TRUE	-	Uint8
5-62	Pulse Output Max Freq #27	ExpressionLimit	All set-ups		TRUE	0	Uint32
5-63	Terminal 29 Pulse Output Variable	null	All set-ups	x	TRUE	-	Uint8
5-65	Pulse Output Max Freq #29	ExpressionLimit	All set-ups	x	TRUE	0	Uint32
	Terminal X30/6 Pulse Output						
5-66	Variable	null	All set-ups		TRUE	-	Uint8
5-68	Pulse Output Max Freq #X30/6	ExpressionLimit	All set-ups		TRUE	0	Uint32
<b>5-7* 24V Encoder Input</b>							
5-70	Term 32/33 Pulses per Revolution	1024 N/A	All set-ups		FALSE	0	Uint16
5-71	Term 32/33 Encoder Direction	[0] Clockwise	All set-ups		FALSE	-	Uint8
<b>5-9* Bus Controlled</b>							
5-90	Digital & Relay Bus Control	0 N/A	All set-ups		TRUE	0	Uint32
5-93	Pulse Out #27 Bus Control	0.00 %	All set-ups		TRUE	-2	N2
5-94	Pulse Out #27 Timeout Preset	0.00 %	1 set-up		TRUE	-2	Uint16
5-95	Pulse Out #29 Bus Control	0.00 %	All set-ups	x	TRUE	-2	N2
5-96	Pulse Out #29 Timeout Preset	0.00 %	1 set-up	x	TRUE	-2	Uint16

\* default setting ( ) display text [ ] value for use in communication via serial communication port

— How to Programme —

□ **6-\*\* Analog In/Out**

Par. No. #	Parameter description	Default value	4-set-up	FC 302 only	Change during operation	Conversion index	Type
<b>6-0* Analog I/O Mode</b>							
6-00	Live Zero Timeout Time	10 s	All set-ups		TRUE	0	Uint8
6-01	Live Zero Timeout Function	[0] Off	All set-ups		TRUE	-	Uint8
<b>6-1* Analog Input 1</b>							
6-10	Terminal 53 Low Voltage	0.07 V	All set-ups		TRUE	-2	Int16
6-11	Terminal 53 High Voltage	10.00 V	All set-ups		TRUE	-2	Int16
6-12	Terminal 53 Low Current	0.14 mA	All set-ups		TRUE	-5	Int16
6-13	Terminal 53 High Current	20.00 mA	All set-ups		TRUE	-5	Int16
		0.000 Reference-					
6-14	Terminal 53 Low Ref./Feedb. Value	FeedbackUnit	All set-ups		TRUE	-3	Int32
6-15	Terminal 53 High Ref./Feedb. Value	ExpressionLimit	All set-ups		TRUE	-3	Int32
6-16	Terminal 53 Filter Time Constant	0.001 s	All set-ups		TRUE	-3	Uint16
<b>6-2* Analog Input 2</b>							
6-20	Terminal 54 Low Voltage	0.07 V	All set-ups		TRUE	-2	Int16
6-21	Terminal 54 High Voltage	10.00 V	All set-ups		TRUE	-2	Int16
6-22	Terminal 54 Low Current	0.14 mA	All set-ups		TRUE	-5	Int16
6-23	Terminal 54 High Current	20.00 mA	All set-ups		TRUE	-5	Int16
		0.000 Reference-					
6-24	Terminal 54 Low Ref./Feedb. Value	FeedbackUnit	All set-ups		TRUE	-3	Int32
6-25	Terminal 54 High Ref./Feedb. Value	ExpressionLimit	All set-ups		TRUE	-3	Int32
6-26	Terminal 54 Filter Time Constant	0.001 s	All set-ups		TRUE	-3	Uint16
<b>6-3* Analog Input 3</b>							
6-30	Terminal X30/11 Low Voltage	0.07 V	All set-ups		TRUE	-2	Int16
6-31	Terminal X30/11 High Voltage	10.00 V	All set-ups		TRUE	-2	Int16
	Term. X30/11 Low Ref./Feedb. Value	0.000 Reference-					
6-34	Value	FeedbackUnit	All set-ups		TRUE	-3	Int32
	Term. X30/11 High Ref./Feedb. Value						
6-35	Value	ExpressionLimit	All set-ups		TRUE	-3	Int32
6-36	Term. X30/11 Filter Time Constant	0.001 s	All set-ups		TRUE	-3	Uint16
<b>6-4* Analog Input 4</b>							
6-40	Terminal X30/12 Low Voltage	0.07 V	All set-ups		TRUE	-2	Int16
6-41	Terminal X30/12 High Voltage	10.00 V	All set-ups		TRUE	-2	Int16
	Term. X30/12 Low Ref./Feedb. Value	0.000 Reference-					
6-44	Value	FeedbackUnit	All set-ups		TRUE	-3	Int32
	Term. X30/12 High Ref./Feedb. Value						
6-45	Value	ExpressionLimit	All set-ups		TRUE	-3	Int32
6-46	Term. X30/12 Filter Time Constant	0.001 s	All set-ups		TRUE	-3	Uint16
<b>6-5* Analog Output 1</b>							
6-50	Terminal 42 Output	null	All set-ups		TRUE	-	Uint8
6-51	Terminal 42 Output Min Scale	0.00 %	All set-ups		TRUE	-2	Int16
6-52	Terminal 42 Output Max Scale	100.00 %	All set-ups		TRUE	-2	Int16
6-53	Terminal 42 Output Bus Control	0.00 %	All set-ups		TRUE	-2	N2
6-54	Terminal 42 Output Timeout Preset	0.00 %	1 set-up		TRUE	-2	Uint16
<b>6-6* Analog Output 2</b>							
6-60	Terminal X30/8 Output	null	All set-ups		TRUE	-	Uint8
6-61	Terminal X30/8 Min. Scale	0.00 %	All set-ups		TRUE	-2	Int16
6-62	Terminal X30/8 Max. Scale	100.00 %	All set-ups		TRUE	-2	Int16

\* default setting ( ) display text [ ] value for use in communication via serial communication port

— How to Programme —

□ **7-\*\*\* Controllers**

Par. No. #	Parameter description	Default value	4-set-up	FC 302 only	Change during operation	Conversion index	Type
<b>7-0* Speed PID Ctrl.</b>							
7-00	Speed PID Feedback Source	null	All set-ups		FALSE	-	Uint8
7-02	Speed PID Proportional Gain	ExpressionLimit	All set-ups		TRUE	-3	Uint16
7-03	Speed PID Integral Time	ExpressionLimit	All set-ups		TRUE	-4	Uint32
7-04	Speed PID Differentiation Time	ExpressionLimit	All set-ups		TRUE	-4	Uint16
7-05	Speed PID Diff. Gain Limit	5.0 N/A	All set-ups		TRUE	-1	Uint16
7-06	Speed PID Lowpass Filter Time	10.0 ms	All set-ups		TRUE	-4	Uint16
7-08	Speed PID Feed Forward Factor	0 %	All set-ups		FALSE	0	Uint16
<b>7-2* Process Ctrl. Feedb</b>							
7-20	Process CL Feedback 1 Resource	[0] No function	All set-ups		TRUE	-	Uint8
7-22	Process CL Feedback 2 Resource	[0] No function	All set-ups		TRUE	-	Uint8
<b>7-3* Process PID Ctrl.</b>							
Process PID Normal/ Inverse							
7-30	Control	[0] Normal	All set-ups		TRUE	-	Uint8
7-31	Process PID Anti Windup	[1] On	All set-ups		TRUE	-	Uint8
7-32	Process PID Start Speed	0 RPM	All set-ups		TRUE	67	Uint16
7-33	Process PID Proportional Gain	0.01 N/A	All set-ups		TRUE	-2	Uint16
7-34	Process PID Integral Time	10000.00 s	All set-ups		TRUE	-2	Uint32
7-35	Process PID Differentiation Time	0.00 s	All set-ups		TRUE	-2	Uint16
7-36	Process PID Diff. Gain Limit	5.0 N/A	All set-ups		TRUE	-1	Uint16
7-38	Process PID Feed Forward Factor	0 %	All set-ups		TRUE	0	Uint16
7-39	On Reference Bandwidth	5 %	All set-ups		TRUE	0	Uint8

\* default setting ( ) display text [ ] value for use in communication via serial communication port

## — How to Programme —

□ **8-\*\* Comm. and Options**

Par. No. #	Parameter description	Default value	4-set-up	FC 302 only	Change during operation	Conversion index	Type
<b>8-0* General Settings</b>							
8-01	Control Site	[0] Digital and ctrl.word	All set-ups		TRUE	-	Uint8
8-02	Control Word Source	null	All set-ups		TRUE	-	Uint8
8-03	Control Word Timeout Time	1.0 s	1 set-up		TRUE	-1	Uint32
8-04	Control Word Timeout Function	[0] Off	1 set-up		TRUE	-	Uint8
8-05	End-of-Timeout Function	[1] Resume set-up	1 set-up		TRUE	-	Uint8
8-06	Reset Control Word Timeout	[0] Do not reset	All set-ups		TRUE	-	Uint8
8-07	Diagnosis Trigger	[0] Disable	2 set-ups		TRUE	-	Uint8
<b>8-1* Ctrl. Word Settings</b>							
8-10	Control Word Profile	[0] FC profile	All set-ups		TRUE	-	Uint8
8-13	Configurable Status Word STW	[1] Profile Default	All set-ups		TRUE	-	Uint8
<b>8-3* FC Port Settings</b>							
8-30	Protocol	[0] FC	1 set-up		TRUE	-	Uint8
8-31	Address	1 N/A	1 set-up		TRUE	0	Uint8
8-32	FC Port Baud Rate	[2] 9600 Baud	1 set-up		TRUE	-	Uint8
8-35	Minimum Response Delay	10 ms	1 set-up		TRUE	-3	Uint16
8-36	Max Response Delay	5000 ms	1 set-up		TRUE	-3	Uint16
8-37	Max Inter-Char Delay	25 ms	1 set-up		TRUE	-3	Uint16
<b>8-4* FC MC protocol set</b>							
8-40	Telegram selection	[1] Standard telegram 1	2 set-ups		TRUE	-	Uint8
<b>8-5* Digital/Bus</b>							
8-50	Coasting Select	[3] Logic OR	All set-ups		TRUE	-	Uint8
8-51	Quick Stop Select	[3] Logic OR	All set-ups		TRUE	-	Uint8
8-52	DC Brake Select	[3] Logic OR	All set-ups		TRUE	-	Uint8
8-53	Start Select	[3] Logic OR	All set-ups		TRUE	-	Uint8
8-54	Reversing Select	[3] Logic OR	All set-ups		TRUE	-	Uint8
8-55	Set-up Select	[3] Logic OR	All set-ups		TRUE	-	Uint8
8-56	Preset Reference Select	[3] Logic OR	All set-ups		TRUE	-	Uint8
<b>8-9* Bus Jog</b>							
8-90	Bus Jog 1 Speed	100 RPM	All set-ups		TRUE	67	Uint16
8-91	Bus Jog 2 Speed	200 RPM	All set-ups		TRUE	67	Uint16

\* default setting ( ) display text [ ] value for use in communication via serial communication port

— How to Programme —

□ **9-\*\* Profibus**

Par. No. #	Parameter description	Default value	4-set-up	FC 302 only	Change during operation	Con- version in- dex	Type
9-00	Setpoint	0 N/A	All set-ups		TRUE	0	Uint16
9-07	Actual Value	0 N/A	All set-ups		FALSE	0	Uint16
9-15	PCD Write Configuration	ExpressionLimit	2 set-ups		TRUE	-	Uint16
9-16	PCD Read Configuration	ExpressionLimit	2 set-ups		TRUE	-	Uint16
9-18	Node Address	126 N/A	1 set-up		TRUE	0	Uint8
9-22	Telegram Selection	[108] PPO 8	1 set-up		TRUE	-	Uint8
9-23	Parameters for Signals	0	All set-ups		TRUE	-	Uint16
9-27	Parameter Edit	[1] Enabled	2 set-ups		FALSE	-	Uint16
		[1] Enable cyclic					
9-28	Process Control	master	2 set-ups		FALSE	-	Uint8
9-44	Fault Message Counter	0 N/A	All set-ups		TRUE	0	Uint16
9-45	Fault Code	0 N/A	All set-ups		TRUE	0	Uint16
9-47	Fault Number	0 N/A	All set-ups		TRUE	0	Uint16
9-52	Fault Situation Counter	0 N/A	All set-ups		TRUE	0	Uint16
9-53	Profibus Warning Word	0 N/A	All set-ups		TRUE	0	V2
		[255] No baudrate					
9-63	Actual Baud Rate	found	All set-ups		TRUE	-	Uint8
9-64	Device Identification	0 N/A	All set-ups		TRUE	0	Uint16
9-65	Profile Number	0 N/A	All set-ups		TRUE	0	OctStr[2]
9-67	Control Word 1	0 N/A	All set-ups		TRUE	0	V2
9-68	Status Word 1	0 N/A	All set-ups		TRUE	0	V2
9-71	Save Data Values	[0] Off	All set-ups		TRUE	-	Uint8
9-72	Drive Reset	[0] No action	1 set-up		FALSE	-	Uint8
9-80	Defined Parameters (1)	0 N/A	All set-ups		FALSE	0	Uint16
9-81	Defined Parameters (2)	0 N/A	All set-ups		FALSE	0	Uint16
9-82	Defined Parameters (3)	0 N/A	All set-ups		FALSE	0	Uint16
9-83	Defined Parameters (4)	0 N/A	All set-ups		FALSE	0	Uint16
9-90	Changed Parameters (1)	0 N/A	All set-ups		FALSE	0	Uint16
9-91	Changed Parameters (2)	0 N/A	All set-ups		FALSE	0	Uint16
9-92	Changed Parameters (3)	0 N/A	All set-ups		FALSE	0	Uint16
9-93	Changed parameters (4)	0 N/A	All set-ups		FALSE	0	Uint16

\* default setting ( ) display text [ ] value for use in communication via serial communication port

— How to Programme —

□ **10-\*\* CAN Fieldbus**

Par. No. #	Parameter description	Default value	4-set-up	FC 302 only	Change during operation	Conversion index	Type
<b>10-0* Common Settings</b>							
10-00	CAN Protocol	null	2 set-ups		FALSE	-	Uint8
10-01	Baud Rate Select	null	2 set-ups		TRUE	-	Uint8
10-02	MAC ID	ExpressionLimit	2 set-ups		TRUE	0	Uint8
10-05	Readout Transmit Error Counter	0 N/A	All set-ups		TRUE	0	Uint8
10-06	Readout Receive Error Counter	0 N/A	All set-ups		TRUE	0	Uint8
10-07	Readout Bus Off Counter	0 N/A	All set-ups		TRUE	0	Uint8
<b>10-1* DeviceNet</b>							
10-10	Process Data Type Selection	null	All set-ups		TRUE	-	Uint8
10-11	Process Data Config Write	ExpressionLimit	2 set-ups		TRUE	-	Uint16
10-12	Process Data Config Read	ExpressionLimit	2 set-ups		TRUE	-	Uint16
10-13	Warning Parameter	0 N/A	All set-ups		TRUE	0	Uint16
10-14	Net Reference	[0] Off	2 set-ups		TRUE	-	Uint8
10-15	Net Control	[0] Off	2 set-ups		TRUE	-	Uint8
<b>10-2* COS Filters</b>							
10-20	COS Filter 1	0 N/A	All set-ups		FALSE	0	Uint16
10-21	COS Filter 2	0 N/A	All set-ups		FALSE	0	Uint16
10-22	COS Filter 3	0 N/A	All set-ups		FALSE	0	Uint16
10-23	COS Filter 4	0 N/A	All set-ups		FALSE	0	Uint16
<b>10-3* Parameter Access</b>							
10-30	Array Index	0 N/A	2 set-ups		TRUE	0	Uint8
10-31	Store Data Values	[0] Off	All set-ups		TRUE	-	Uint8
10-32	Devicenet Revision	ExpressionLimit	All set-ups		TRUE	0	Uint16
10-33	Store Always	[0] Off	1 set-up		TRUE	-	Uint8
10-39	Devicenet F Parameters	0 N/A	All set-ups		TRUE	0	Uint32
<b>10-5* CANopen</b>							
10-50	Process Data Config Write.	ExpressionLimit	2 set-ups		TRUE	-	Uint16
10-51	Process Data Config Read.	ExpressionLimit	2 set-ups		TRUE	-	Uint16

\* default setting ( ) display text [ ] value for use in communication via serial communication port

— How to Programme —

□ **13-\*\* Smart Logic**

Par. No. #	Parameter description	Default value	4-set-up	FC 302 only	Change during operation	Conversion index	Type
<b>13-0* SLC Settings</b>							
13-00	SL Controller Mode	null	2 set-ups		TRUE	-	Uint8
13-01	Start Event	null	2 set-ups		TRUE	-	Uint8
13-02	Stop Event	null	2 set-ups		TRUE	-	Uint8
13-03	Reset SLC	[0] Do not reset SLC	All set-ups		TRUE	-	Uint8
<b>13-1* Comparators</b>							
13-10	Comparator Operand	null	2 set-ups		TRUE	-	Uint8
13-11	Comparator Operator	null	2 set-ups		TRUE	-	Uint8
13-12	Comparator Value	ExpressionLimit	2 set-ups		TRUE	-3	Int32
<b>13-2* Timers</b>							
13-20	SL Controller Timer	ExpressionLimit	1 set-up		TRUE	-3	TimD
<b>13-4* Logic Rules</b>							
13-40	Logic Rule Boolean 1	null	2 set-ups		TRUE	-	Uint8
13-41	Logic Rule Operator 1	null	2 set-ups		TRUE	-	Uint8
13-42	Logic Rule Boolean 2	null	2 set-ups		TRUE	-	Uint8
13-43	Logic Rule Operator 2	null	2 set-ups		TRUE	-	Uint8
13-44	Logic Rule Boolean 3	null	2 set-ups		TRUE	-	Uint8
<b>13-5* States</b>							
13-51	SL Controller Event	null	2 set-ups		TRUE	-	Uint8
13-52	SL Controller Action	null	2 set-ups		TRUE	-	Uint8

\* default setting ( ) display text [ ] value for use in communication via serial communication port

— How to Programme —

□ **14-\*\* Special Functions**

Par. #	Parameter description	Default value	4-set-up	FC 302 only	Change during operation	Conversion index	Type
<b>14-0* Inverter Switching</b>							
14-00	Switching Pattern	[1] SFAVM	All set-ups		TRUE	-	Uint8
14-01	Switching Frequency	null	All set-ups		TRUE	-	Uint8
14-03	Overmodulation	[1] On	All set-ups		FALSE	-	Uint8
14-04	PWM Random	[0] Off	All set-ups		TRUE	-	Uint8
<b>14-1* Mains On/Off</b>							
14-12	Function at Mains Imbalance	[0] Trip	All set-ups		TRUE	-	Uint8
<b>14-2* Trip Reset</b>							
14-20	Reset Mode	[0] Manual reset	All set-ups		TRUE	-	Uint8
14-21	Automatic Restart Time	10 s	All set-ups		TRUE	0	Uint16
14-22	Operation Mode	[0] Normal operation	All set-ups		TRUE	-	Uint8
14-23	Typecode Setting	null	2 set-ups		FALSE	-	Uint16
14-25	Trip Delay at Torque Limit	60 s	All set-ups		TRUE	0	Uint8
14-26	Trip Delay at Inverter Fault	ExpressionLimit	All set-ups		TRUE	0	Uint8
14-28	Production Settings	[0] No action	All set-ups		TRUE	-	Uint8
14-29	Service Code	0 N/A	All set-ups		TRUE	0	Int32
<b>14-3* Current Limit Ctrl.</b>							
Current Lim Cont, Proportional							
14-30	Gain	100 %	All set-ups		FALSE	0	Uint16
Current Lim Contr, Integration							
14-31	Time	0.020 s	All set-ups		FALSE	-3	Uint16
<b>14-4* Energy Optimising</b>							
14-40	VT Level	66 %	All set-ups		FALSE	0	Uint8
14-41	AEO Minimum Magnetisation	40 %	All set-ups		TRUE	0	Uint8
14-42	Minimum AEO Frequency	10 Hz	All set-ups		TRUE	0	Uint8
14-43	Motor Cosphi	ExpressionLimit	All set-ups		TRUE	-2	Uint16
<b>14-5* Environment</b>							
14-50	RFI Filter	[1] On	1 set-up	x	FALSE	-	Uint8
14-52	Fan Control	[0] Auto	All set-ups		TRUE	-	Uint8
14-53	Fan Monitor	[1] Warning	All set-ups		TRUE	-	Uint8

\* default setting ( ) display text [ ] value for use in communication via serial communication port



— How to Programme —

□ **15-\*\* Drive Information**

Par. No. #	Parameter description	Default value	4-set-up	FC 302 only	Change during operation	Con- version index	Type
<b>15-0* Operating Data</b>							
15-00	Operating Hours	0 h	All set-ups		FALSE	74	Uint32
15-01	Running Hours	0 h	All set-ups		FALSE	74	Uint32
15-02	kWh Counter	0 kWh	All set-ups		FALSE	75	Uint32
15-03	Power Up's	0 N/A	All set-ups		FALSE	0	Uint32
15-04	Over Temp's	0 N/A	All set-ups		FALSE	0	Uint16
15-05	Over Volt's	0 N/A	All set-ups		FALSE	0	Uint16
15-06	Reset kWh Counter	[0] Do not reset	All set-ups		TRUE	-	Uint8
15-07	Reset Running Hours Counter	[0] Do not reset	All set-ups		TRUE	-	Uint8
<b>15-1* Data Log Settings</b>							
15-10	Logging Source	0	2 set-ups		TRUE	-	Uint16
15-11	Logging Interval	ExpressionLimit	2 set-ups		TRUE	-3	TimD
15-12	Trigger Event	[0] False	1 set-up		TRUE	-	Uint8
15-13	Logging Mode	[0] Log always	2 set-ups		TRUE	-	Uint8
15-14	Samples Before Trigger	50 N/A	2 set-ups		TRUE	0	Uint8
<b>15-2* Historic Log</b>							
15-20	Historic Log: Event	0 N/A	All set-ups		FALSE	0	Uint8
15-21	Historic Log: Value	0 N/A	All set-ups		FALSE	0	Uint32
15-22	Historic Log: Time	0 ms	All set-ups		FALSE	-3	Uint32
<b>15-3* Fault Log</b>							
15-30	Fault Log: Error Code	0 N/A	All set-ups		FALSE	0	Uint8
15-31	Fault Log: Value	0 N/A	All set-ups		FALSE	0	Int16
15-32	Fault Log: Time	0 s	All set-ups		FALSE	0	Uint32
<b>15-4* Drive Identification</b>							
15-40	FC Type	0 N/A	All set-ups		FALSE	0	VisStr[6]
15-41	Power Section	0 N/A	All set-ups		FALSE	0	VisStr[20]
15-42	Voltage	0 N/A	All set-ups		FALSE	0	VisStr[20]
15-43	Software Version	0 N/A	All set-ups		FALSE	0	VisStr[5]
15-44	Ordered Typecode String	0 N/A	All set-ups		FALSE	0	VisStr[40]
15-45	Actual Typecode String	0 N/A	All set-ups		FALSE	0	VisStr[40]
15-46	Frequency Converter Ordering No	0 N/A	All set-ups		FALSE	0	VisStr[8]
15-47	Power Card Ordering No	0 N/A	All set-ups		FALSE	0	VisStr[8]
15-48	LCP Id No	0 N/A	All set-ups		FALSE	0	VisStr[20]
15-49	SW ID Control Card	0 N/A	All set-ups		FALSE	0	VisStr[20]
15-50	SW ID Power Card	0 N/A	All set-ups		FALSE	0	VisStr[20]
	Frequency Converter Serial						
15-51	Number	0 N/A	All set-ups		FALSE	0	VisStr[10]
15-53	Power Card Serial Number	0 N/A	All set-ups		FALSE	0	VisStr[19]
<b>15-6* Option Ident</b>							
15-60	Option Mounted	0 N/A	All set-ups		FALSE	0	VisStr[30]
15-61	Option SW Version	0 N/A	All set-ups		FALSE	0	VisStr[20]
15-62	Option Ordering No	0 N/A	All set-ups		FALSE	0	VisStr[8]
15-63	Option Serial No	0 N/A	All set-ups		FALSE	0	VisStr[18]
15-70	Option in Slot A	0 N/A	All set-ups		FALSE	0	VisStr[30]
15-71	Slot A Option SW Version	0 N/A	All set-ups		FALSE	0	VisStr[20]
15-72	Option in Slot B	0 N/A	All set-ups		FALSE	0	VisStr[30]
15-73	Slot B Option SW Version	0 N/A	All set-ups		FALSE	0	VisStr[20]
15-74	Option in Slot C0	0 N/A	All set-ups		FALSE	0	VisStr[30]
15-75	Slot C0 Option SW Version	0 N/A	All set-ups		FALSE	0	VisStr[20]
15-76	Option in Slot C1	0 N/A	All set-ups		FALSE	0	VisStr[30]
15-77	Slot C1 Option SW Version	0 N/A	All set-ups		FALSE	0	VisStr[20]
<b>15-9* Parameter Info</b>							
15-92	Defined Parameters	0 N/A	All set-ups		FALSE	0	Uint16
15-93	Modified Parameters	0 N/A	All set-ups		FALSE	0	Uint16
15-99	Parameter Metadata	0 N/A	All set-ups		FALSE	0	Uint16

\* default setting ( ) display text [ ] value for use in communication via serial communication port

— How to Programme —

□ **16-\*\* Data Readouts**

Par. No. #	Parameter description	Default value	4-set-up	FC 302 only	Change during operation	Conversion index	Type
<b>16-0* General Status</b>							
16-00	Control Word	0 N/A	All set-ups		FALSE	0	V2
		0.000 Reference-					
16-01	Reference [Unit]	FeedbackUnit	All set-ups		FALSE	-3	Int32
16-02	Reference %	0.0 %	All set-ups		FALSE	-1	Int16
16-03	Status Word	0 N/A	All set-ups		FALSE	0	V2
16-05	Main Actual Value [%]	0.00 %	All set-ups		FALSE	-2	N2
		0.00 CustomRead-					
16-09	Custom Readout	outUnit	All set-ups		FALSE	-2	Int32
<b>16-1* Motor Status</b>							
16-10	Power [kW]	0.00 kW	All set-ups		FALSE	1	Int32
16-11	Power [hp]	0.00 hp	All set-ups		FALSE	-2	Int32
16-12	Motor Voltage	0.0 V	All set-ups		FALSE	-1	Uint16
16-13	Frequency	0.0 Hz	All set-ups		FALSE	-1	Uint16
16-14	Motor Current	0.00 A	All set-ups		FALSE	-2	Int32
16-15	Frequency [%]	0.00 %	All set-ups		FALSE	-2	N2
16-16	Torque	0.0 Nm	All set-ups		FALSE	-1	Int16
16-17	Speed [RPM]	0 RPM	All set-ups		FALSE	67	Int32
16-18	Motor Thermal	0 %	All set-ups		FALSE	0	Uint8
16-19	KTY sensor temperature	0 °C	All set-ups		FALSE	100	Int16
16-20	Motor Angle	0 N/A	All set-ups		TRUE	0	Uint16
<b>16-3* Drive Status</b>							
16-30	DC Link Voltage	0 V	All set-ups		FALSE	0	Uint16
16-32	Brake Energy /s	0.000 kW	All set-ups		FALSE	0	Uint32
16-33	Brake Energy /2 min	0.000 kW	All set-ups		FALSE	0	Uint32
16-34	Heatsink Temp.	0 °C	All set-ups		FALSE	100	Uint8
16-35	Inverter Thermal	0 %	All set-ups		FALSE	0	Uint8
16-36	Inv. Nom. Current	ExpressionLimit	All set-ups		FALSE	-2	Uint32
16-37	Inv. Max. Current	ExpressionLimit	All set-ups		FALSE	-2	Uint32
16-38	SL Controller State	0 N/A	All set-ups		FALSE	0	Uint8
16-39	Control Card Temp.	0 °C	All set-ups		FALSE	100	Uint8
16-40	Logging Buffer Full	[0] No	All set-ups		TRUE	-	Uint8
<b>16-5* Ref. &amp; Feedb.</b>							
16-50	External Reference	0.0 N/A	All set-ups		FALSE	-1	Int16
16-51	Pulse Reference	0.0 N/A	All set-ups		FALSE	-1	Int16
		0.000 Reference-					
16-52	Feedback [Unit]	FeedbackUnit	All set-ups		FALSE	-3	Int32
16-53	Digi Pot Reference	0.00 N/A	All set-ups		FALSE	-2	Int16
<b>16-6* Inputs &amp; Outputs</b>							
16-60	Digital Input	0 N/A	All set-ups		FALSE	0	Uint16
16-61	Terminal 53 Switch Setting	[0] Current	All set-ups		FALSE	-	Uint8
16-62	Analog Input 53	0.000 N/A	All set-ups		FALSE	-3	Int32
16-63	Terminal 54 Switch Setting	[0] Current	All set-ups		FALSE	-	Uint8
16-64	Analog Input 54	0.000 N/A	All set-ups		FALSE	-3	Int32
16-65	Analog Output 42 [mA]	0.000 N/A	All set-ups		FALSE	-3	Int16
16-66	Digital Output [bin]	0 N/A	All set-ups		FALSE	0	Int16
16-67	Freq. Input #29 [Hz]	0 N/A	All set-ups	x	FALSE	0	Int32
16-68	Freq. Input #33 [Hz]	0 N/A	All set-ups		FALSE	0	Int32
16-69	Pulse Output #27 [Hz]	0 N/A	All set-ups		FALSE	0	Int32
16-70	Pulse Output #29 [Hz]	0 N/A	All set-ups	x	FALSE	0	Int32
16-71	Relay Output [bin]	0 N/A	All set-ups		FALSE	0	Int16
16-72	Counter A	0 N/A	All set-ups		TRUE	0	Int32
16-73	Counter B	0 N/A	All set-ups		TRUE	0	Int32
16-74	Prec. Stop Counter	0 N/A	All set-ups		TRUE	0	Uint32
16-75	Analog In X30/11	0.000 N/A	All set-ups		FALSE	-3	Int32
16-76	Analog In X30/12	0.000 N/A	All set-ups		FALSE	-3	Int32
16-77	Analog Out X30/8 [mA]	0.000 N/A	All set-ups		FALSE	-3	Int16

\* default setting ( ) display text [ ] value for use in communication via serial communication port

— How to Programme —

Par. No. #	Parameter description	Default value	4-set-up	FC 302 only	Change during operation	Conversion index	Type
<b>16-8* Fieldbus &amp; FC Port</b>							
16-80	Fieldbus CTW 1	0 N/A	All set-ups		FALSE	0	V2
16-82	Fieldbus REF 1	0 N/A	All set-ups		FALSE	0	N2
16-84	Comm. Option STW	0 N/A	All set-ups		FALSE	0	V2
16-85	FC Port CTW 1	0 N/A	All set-ups		FALSE	0	V2
16-86	FC Port REF 1	0 N/A	All set-ups		FALSE	0	N2
<b>16-9* Diagnosis Readouts</b>							
16-90	Alarm Word	0 N/A	All set-ups		FALSE	0	Uint32
16-91	Alarm word 2	0 N/A	All set-ups		FALSE	0	Uint32
16-92	Warning Word	0 N/A	All set-ups		FALSE	0	Uint32
16-93	Warning word 2	0 N/A	All set-ups		FALSE	0	Uint32
16-94	Ext. Status Word	0 N/A	All set-ups		FALSE	0	Uint32

\* default setting ( ) display text [ ] value for use in communication via serial communication port

## — How to Programme —

□ **17-\*\* Motor Feedb.Option**

Par. No. #	Parameter description	Default value	4-set-up	FC 300 series	Change during operation	Conversion index	Type
<b>17-1* Inc. Enc. Interface</b>							
17-10	Signal Type	[1] RS422 (5V TTL)	All set-ups		FALSE	-	Uint8
17-11	Resolution (PPR)	1024 N/A	All set-ups		FALSE	0	Uint16
<b>17-2* Abs. Enc. Interface</b>							
17-20	Protocol Selection	[0] None	All set-ups		FALSE	-	Uint8
17-21	Resolution (Positions/Rev)	ExpressionLimit	All set-ups		FALSE	0	Uint32
17-24	SSI Data Length	13 N/A	All set-ups		TRUE	0	Uint8
17-25	Clock Rate	260 kHz	All set-ups		TRUE	3	Uint16
17-26	SSI Data Format	[0] Grey code	All set-ups		TRUE	-	Uint8
17-34	HIPERFACE Baudrate	[4] 9600	All set-ups		FALSE	-	Uint8
<b>17-6* Monitoring and App.</b>							
17-60	Encoder Positive Direction	[0] Clockwise	All set-ups		FALSE	-	Uint8
17-61	Encoder Signal Monitoring	[0] Disabled	All set-ups		TRUE	-	Uint8

\* default setting ( ) display text [ ] value for use in communication via serial communication port

□ **Serial communication via RS 485 Interface**

□ **Protocols**

Master-slave communication.

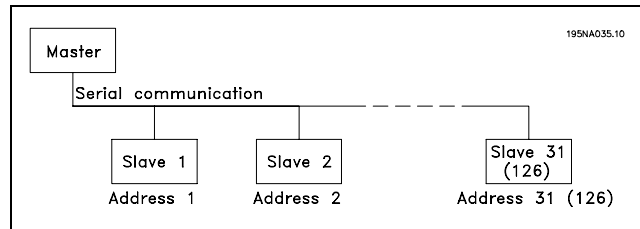

□ **Telegram Traffic**

Control and response telegrams

The master controls telegram traffic in a master-slave system. You can connect a maximum of 31 slaves to a master unless you use repeaters. If so, you can connect a maximum of 126 slaves to a master.

The master constantly sends telegrams addressed to the slaves and waits for their response telegrams. The slave response time is maximum 50 ms.

A slave can only send a response telegram if it has received an error-free telegram addressed to itself.

Broadcast

A master can send the same telegram simultaneously to all slaves connected to the bus. During this broadcast communication the slave does not send any response telegrams to the master on whether the telegram is correctly received. Broadcast communication is set up in address format (ADR), see *Telegram structure*.

Content of a character (byte)

Each character transferred begins with a start bit. Then 8 data bits are transferred, corresponding to a byte. Each character is secured via a parity bit, which is set at "1" when it reaches parity (i.e. when there is an equal number of 1's in the 8 data bits and the parity bit in total). A character is completed by a stop bit, thus consisting of 11 bits in all.

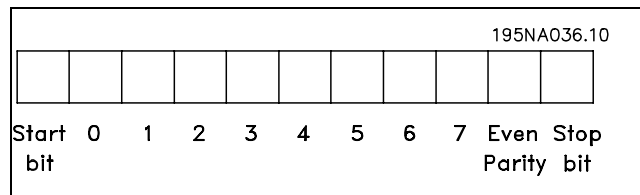

□ **Telegram Structure**

Each telegram begins with a start character (STX) = 02 Hex, followed by a byte denoting the telegram length (LGE) and a byte denoting the frequency converter address (ADR). A number of data bytes (variable, depending on the type of telegram) follows. The telegram is completed by a data control byte (BCC).

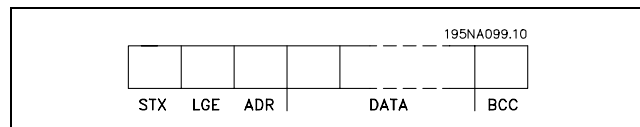

— How to Programme —

Telegram timing

The communication speed between a master and a slave depends on the baud rate. The frequency converter's baud rate must be the same as the master's baud rate (selected in par. 8-32 *FC Port Baud Rate*).

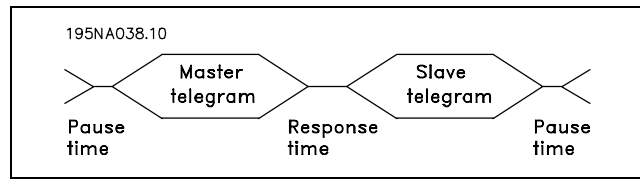

After a response telegram from the slave, make sure there is a pause of at least 2 characters (22 bits) before the master sends a new telegram. At a baud rate of 9600 baud, make sure there is a pause of at least 2.3 ms. When the master has completed the telegram, the slave's response time to the master is maximum of 20 ms. There is a pause of at least 2 characters.

- Pause time, min: 2 characters
- Response time, min: 2 characters
- Response time, max: 20 ms

The time between the individual characters in a telegram may not exceed 2 characters, and the telegram must be completed within 1.5 x nominal telegram time. At a baud rate of 9600 baud and a telegram length of 16 bytes, the telegram is completed after 27.5 ms.

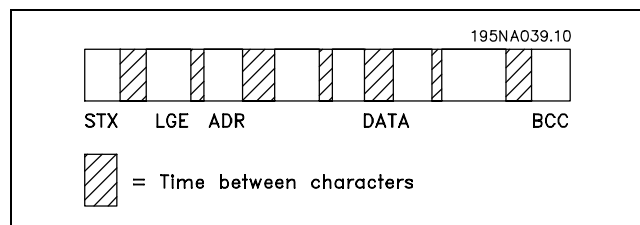

Telegram length (LGE)

The telegram length is the number of data bytes plus the address byte ADR and the data control byte BCC.

The length of telegrams with 4 data bytes is:  $LGE = 4 + 1 + 1 = 6$  bytes

The length of telegrams with 12 data bytes is:  $LGE = 12 + 1 + 1 = 14$  bytes

The length of telegrams containing texts is 10+n bytes. 10 represents the fixed characters, while the 'n' is variable (depending on the length of the text).

Frequency converter address (ADR)

Two different address formats are used. The frequency converter's address range is either 1-31 or 1-126.

1. Address format 1-31

The byte for address range 1-31 has the shown profile:

Bit 7 = 0 (address format 1-31 active)

Bit 6 is not used

Bit 5 = 1: Broadcast, address bits (0-4) are not used

Bit 5 = 0: No Broadcast

Bit 0-4 = Frequency converter address 1-31

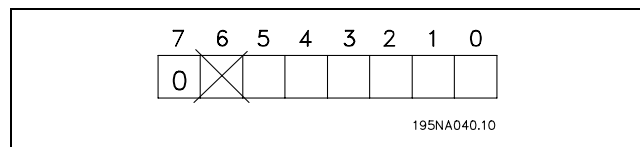

— How to Programme —

2. Address format 1-126

The byte for address range 1 - 126 has the shown profile:

- Bit 7 = 1 (address format 1-126 active)
- Bit 0-6 = Frequency converter address 1-126
- Bit 0-6 = 0 Broadcast

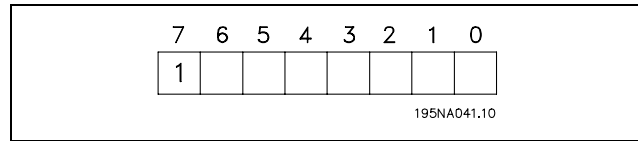

The slave returns the address byte unchanged to the master in the response telegram.

Example:

Writing to frequency converter address 22 (16H) with address format 1-31:

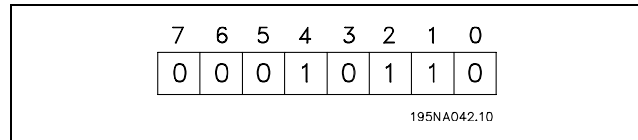

Data control byte (BCC)

The data control byte is explained in this example: Before the first byte in the telegram is received, the Calculated CheckSum (BCS) is 0.

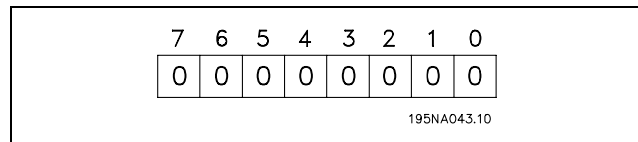

When the first byte (02H) is received:

BCS = BCC EXOR "first byte"  
(EXOR = exclusive-or)

Each subsequent byte gates with BCS EXOR and produces a new BCC, e.g.:

BCS	= 0 0 0 0 0 0 0 0 (00 H)
	EXOR
1. byte	= 0 0 0 0 0 0 1 0 (02H)
BCC	= 0 0 0 0 0 0 1 0 (02H)

BCS	= 0 0 0 0 0 0 1 0 (02H)
	EXOR
2nd byte	= 1 1 0 1 0 1 1 0 (D6H)
BCC	= 1 1 0 1 0 1 0 0 (D4H)

□ **Data Character (byte)**

The structure of data blocks depends on the type of telegram. There are three telegram types, and the type applies for both control telegrams (master=>slave) and response telegrams (slave=>master). The three types of telegram are:

Parameter block: Used to transfer parameters between master and slave. The data block is made up of 12 bytes (6 words) and also contains the process block.

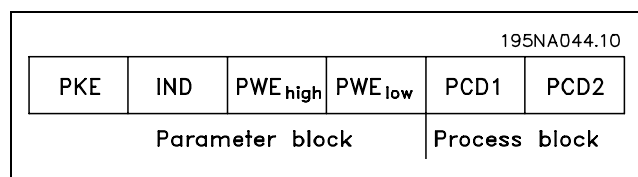

— How to Programme —

Process block: Made up of a data block of four bytes (2 words) and contains:

- Control word and reference value (from master to slave)
- Status word and present output frequency (from slave to master)

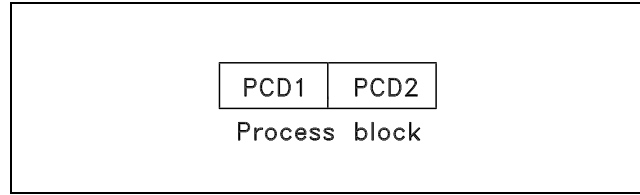

Text block is used to read or write texts via the data block.

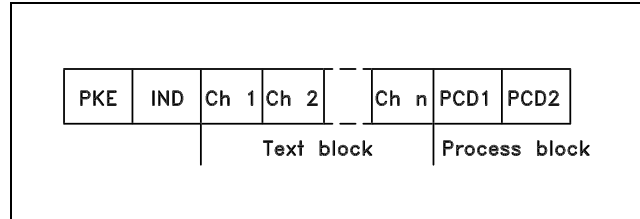

Parameter commands and responses (AK)

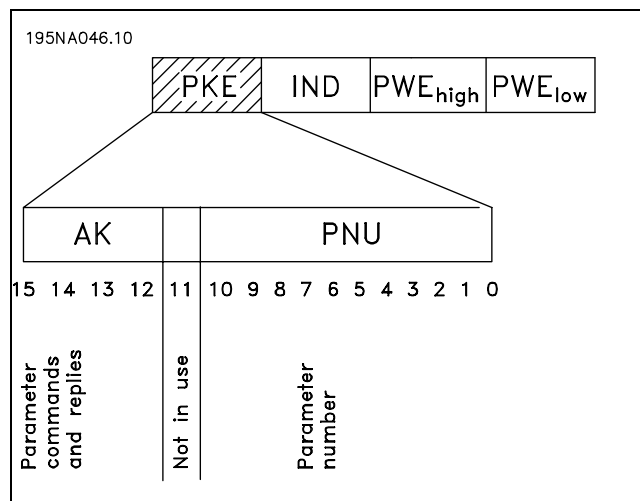

Bits no. 12-15 transfers parameter commands from master to slave and returns processed slave responses to the master.

Parameter commands master=>slave				
Bit no.	Parameter command			
15	14	13	12	
0	0	0	0	No command
0	0	0	1	Read parameter value
0	0	1	0	Write parameter value in RAM (word)
0	0	1	1	Write parameter value in RAM (double word)
1	1	0	1	Write parameter value in RAM and EEPROM (double word)
1	1	1	0	Write parameter value in RAM and EEPROM (word)
1	1	1	1	Read/write text

\* default setting ( ) display text [ ] value for use in communication via serial communication port



— How to Programme —

Response slave=>master				
Bit no.		Response		
15	14	13	12	
0	0	0	0	No response
0	0	0	1	Parameter value transferred (word)
0	0	1	0	Parameter value transferred (double word)
0	1	1	1	Command cannot be performed
1	1	1	1	Text transferred

If the command cannot be performed, the slave sends this response: 0111 *Command cannot be performed* and issues the following fault report in the parameter value (PWE):

Response (0111)	Fault Report
0	The parameter number used does not exist
1	There is no write access to the defined parameter
2	Data value exceeds the parameter's limits
3	The sub index used does not exist
4	The parameter is not the array type
5	The data type does not match the defined parameter
17	Data change in the defined parameter is not possible in the frequency converter's present mode. Certain parameters can only be changed when the motor is turned off
130	There is no bus access to the defined parameter
131	Data change is not possible because factory Setup is selected

Parameter number (PNU)

Bits no. 0-10 transfers parameter numbers. The relevant parameter's function is defined in the parameter description in the chapter *How to Programme*.

Index

Index is used together with the parameter number to read/write-access parameters with an index, e.g. par. 15-30 *Error Code*. The index consists of 2 bytes - one lowbyte and one highbyte. Only the lowbyte is used as an index.



Example - Index:

The first error code (index [1]) in par. 15-30 *Error Code* must be read.

PKE = 15 FA Hex (read par. 15-30 *Error Code*.)

IND = 0001 Hex - Index no. 1.

The frequency converter responds in the parameter value block (PWE) with a fault code value from 1 - 99. See *Summary of Warnings and Alarms* to identify the fault code.

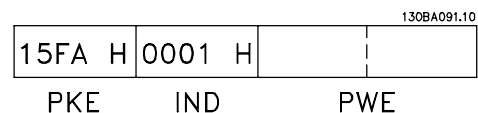

\* default setting ( ) display text [ ] value for use in communication via serial communication port

— How to Programme —

Parameter value (PWE)

The parameter value block consists of 2 words (4 bytes), and the value depends on the defined command (AK). If the master prompts for a parameter value, the PWE block does not contain a value.

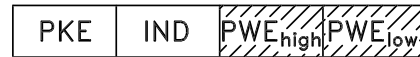

If you want the master to change a parameter value (write), the new value is written in the PWE block and sent to the slave.

If the slave responds to a parameter request (read command), the present parameter value in the PWE block is transferred and returned to the master.

If a parameter contains not a numerical value but several data options, e.g. par. 0-01 *Language* where [0] corresponds to *English*, and [4] corresponds to *Danish*, select the data value by entering the value in the PWE block. See *Example - Selecting a data value*.

Via serial communication it is only possible to read parameters that have data type 9 (text string). Par. 15-40 to 15-33 *Drive Identification* is data type 9. For example, you can read the unit size and mains voltage range in par. 15-40 *FC Type*.

When a text string is transferred (read), the length of the telegram is variable, and the texts are of different lengths. The telegram length is defined in the telegram's second byte, known as LGE.

To read a text via the PWE block, set the parameter command (AK) to 'F' Hex.

The index character indicates if the command is read or write. In a read command, the index must have the shown format:

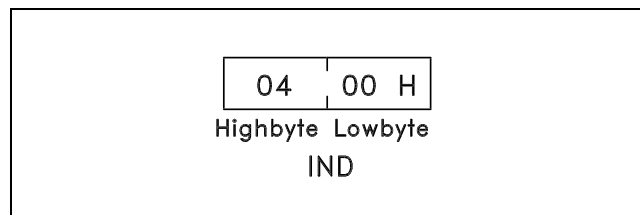

Some frequency converters have parameters in which you can write a text. To write a text via the PWE block, set the parameter command (AK) to 'F' Hex. For a write command the text must have the shown format:

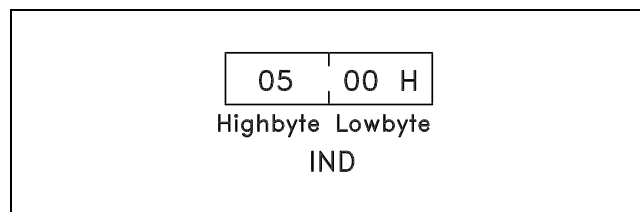

Data types supported by frequency converter:

Unsigned means that there is no operational sign in the telegram.

Data types	Description
3	Integer 16
4	Integer 32
5	Unsigned 8
6	Unsigned 16
7	Unsigned 32
9	Text string
10	Byte string
13	Time difference
33	Reserved
35	Bit sequence

— How to Programme —

Example - Write a parameter value:

Change par. 4-14 *Motor Speed High Limit* to 100 Hz. After a mains failure, recall the value to write it in EEPROM.

PKE = E19E Hex - Write for par. 4-14

*Motor Speed High Limit*

IND = 0000 Hex

PWE<sub>HIGH</sub> = 0000 Hex

PWE<sub>LOW</sub> = 03E8 Hex - Data value 1000, corresponding to 100 Hz, see conversion.

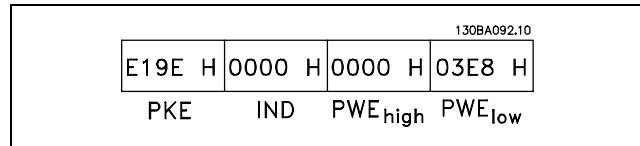

The response from the slave to the master will be:

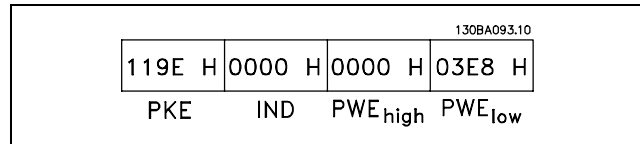

Example - Reading a parameter value:

Requires a value in par. 3-41 *Ramp 1 Up Time*.

The master sends the following request:

PKE = 1155 Hex - read par. 3-41 *Ramp 1 Up Time*

IND = 0000 Hex

PWE<sub>HIGH</sub> = 0000 Hex

PWE<sub>LOW</sub> = 0000 Hex

If the value in par. 3-41 *Ramp 1 Up Time* is 10 s, the response from the slave to the master is:

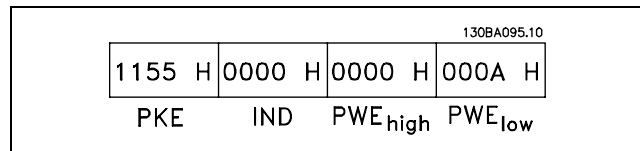
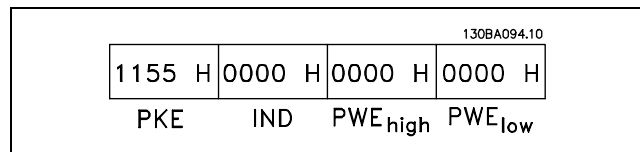

Conversion:

The various attributes of each parameter are displayed in section *Factory Settings*. A parameter value is only transferred as a whole number. Thus, use a conversion factor to transfer decimals.

Example:

Par. 4-12 *Motor Speed, Low Limit* has a conversion factor of 0.1. If you wish to preset the minimum frequency to 10 Hz, transfer the value 100. A conversion factor of 0.1 means that the value transferred is multiplied by 0.1. The value 100 is thus perceived as 10.0.

Conversion table	
Conversion index	Conversion factor
74	0.1
2	100
1	10
0	1
-1	0.1
-2	0.01
-3	0.001
-4	0.0001
-5	0.00001

— How to Programme —

□ **Process Words**

The block of process words is divided into two blocks of 16 bits, which always occur in the defined sequence.

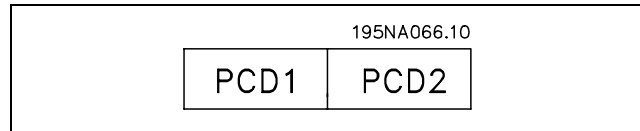

	PCD 1	PCD 2
Control telegram (master=>slave)	Control word	Reference-value
Control telegram (slave=>master)	Status word	Present outp.frequency

□ **Control Word According to FC Profile (CTW)**

To select FC protocol in the control word, set par. 8-10 Control word profile to FC protocol [0]. The control sends commands from a master (PLC or PC) to a slave (frequency converter).

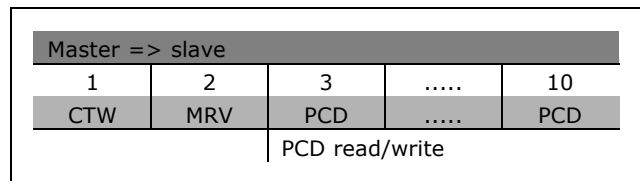

**Explanation of the Control Bits**

Bit	Bit value = 0	Bit value = 1
00	Reference value	external selection lsb
01	Reference value	external selection msb
02	DC brake	Ramp
03	Coasting	No coasting
04	Quick stop	Ramp
05	Freeze output	use ramp
06	Ramp stop	Start
07	No function	Reset
08	No function	Jog
09	Ramp 1	Ramp 2
10	Data not valid	Data valid
11	Relay 01 open	Relay 01 active
12	Relay 02 open (FC 302 only)	Relay 02 active (FC 302 only)
13	Parameter set-up	selection lsb
14	Parameter set-up	selection msb
15	No function	Reverse

Bits 00/01

Use bits 00 and 01 to choose between the four reference values, which are pre-programmed in par. 3-10 *Preset Reference* according to the shown table:

\* default setting ( ) display text [ ] value for use in communication via serial communication port

## — How to Programme —

**NB!:**

Make a selection in par. 8-56 *Preset Reference Select* to define how Bit 00/01 gates with the corresponding function on the digital inputs.

Programmed ref. value	Par.	Bit 01	Bit 00
1	3-10 [0]	0	0
2	3-10 [1]	0	1
3	3-10 [2]	1	0
4	3-10 [3]	1	1

Bit 02, DC brake:

Bit 02 = '0': DC braking and stop. Set braking current and duration in par. 2-01 *DC Brake Current* and 2-02 *DC Braking Time*. Bit 02 = '1' leads to ramping.

Bit 03, Coasting:

Bit 03 = '0': The frequency converter immediately "lets go" of the motor, (the output transistors are "shut off") and it coasts to a standstill. Bit 03 = '1': The frequency converter starts the motor if the other starting conditions are met.

**NB!:**

Make a selection in par. 8-50 *Coasting Select* to define how Bit 03 gates with the corresponding function on a digital input.

Bit 04, Quick stop:

Bit 04 = '0': Makes the motor speed ramp down to stop (set in par. 3-81 *Quick Stop Ramp Time*).

Bit 05, Freeze output frequency:

Bit 05 = '0': The present output frequency (in Hz) freezes. Change the frozen output frequency only by means of the digital inputs (par. 5-10 to 5-15) programmed to Speed up and Slow down.

**NB!:**

If Freeze output is active, the frequency converter can only be stopped by the following:

- Bit 03 Coasting stop
- Bit 02 DC braking
- Digital input (par. 5-10 to 5-15) programmed to DC braking, Coasting stop, or Reset and coasting stop.

Bit 06, Ramp stop/start:

Bit 06 = '0': Causes a stop and makes the motor speed ramp down to stop via the selected ramp down par.

Bit 06 = '1': Permits the frequency converter to start the motor, if the other starting conditions are met.

**NB!:**

Make a selection in par. 8-53 *Start Select* to define how Bit 06 Ramp stop/start gates with the corresponding function on a digital input.

Bit 07, Reset: Bit 07 = '0': No reset. Bit 07 = '1': Resets a trip. Reset is activated on the signal's leading edge, i.e. when changing from logic '0' to logic '1'.

Bit 08, Jog:

Bit 08 = '1': The output frequency is determined by par. 3-19 *Jog Speed*.

Bit 09, Selection of ramp 1/2:

Bit 09 = "0": Ramp 1 is active (par. 3-40 to 3-47). Bit 09 = "1": Ramp 2 (par. 3-50 to 3-57) is active.

— How to Programme —

Bit 10, Data not valid/Data valid:

Tell the frequency converter whether to use or ignore the control word. Bit 10 = '0': The control word is ignored. Bit 10 = '1': The control word is used. This function is relevant because the telegram always contains the control word, regardless of the telegram type. Thus, you can turn off the control word if you do not want to use it when updating or reading parameters.

Bit 11, Relay 01:

Bit 11 = "0": Relay not activated. Bit 11 = "1": Relay 01 activated provided that Control word bit 11 is chosen in par. 5-40.

Bit 12, Relay 02 (FC 302 only):

Bit 12 = "0": Relay 2is not activated. Bit 12 = "1": Relay 02 is activated provided that Control word bit 12 is chosen in par. 5-40.

Bit 13/14, Selection of set-up:

Use bits 13 and 14 to choose from the four menu set-ups according to the shown table. The function is only possible when Multi Set-Ups is selected in par. 0-10 *Active Set-Up*.

Set-up	Bit 14	Bit 13
1	0	0
2	0	1
3	1	0
4	1	1



**NB!:**

Make a selection in par. 8-55 *Set-up select* to define how Bit 13/14 gates with the corresponding function on the digital inputs.

Bit 15 Reverse:

Bit 15 = '0': No reversing. Bit 15 = '1': Reversing. In the default setting, reversing is set to digital in par. 8-54 *Reversing Select*. Bit 15 causes reversing only when Ser. communication, Logic or or Logic and is selected.

— How to Programme —

□ **Status Word According to FC Profile (STW)**

The status word informs the master (e.g. a PC) of the slave (frequency converter) operation mode.

Slave => master				
1	2	3	.....	10
STW	MAV	PCD	.....	PCD
		PCD read/write		

**Explanation of the Status Bits**

Bit	Bit value = 0	Bit value = 1
00	Control not ready	Control ready
01	Drive not ready	Drive ready
02	Coasting	Enable
03	No error	Trip
04	Reserved	-
05	Reserved	-
06	No error	Triplock
07	No warning	Warning
08	Speed ≠ reference	Speed = reference
09	Local operation	Bus control
10	Out of frequency limit	Frequency limit OK
11	No operation	In operation
12	Drive OK	True if brake Warning/Failure
13	Voltage OK	Voltage exceeded
14	Torque OK	Torque exceeded
15	Timer OK	Timer exceeded

Bit 00, Control not ready/ready:

Bit 00 = '0': The frequency converter trips. Bit 00 = '1': The frequency converter controls are ready but the power component does not necessarily receive any power supply (in case of external 24 V supply to controls).

Bit 01, Drive ready:

Bit 01 = '1': The frequency converter is ready for operation but the coasting command is active via the digital inputs or via serial communication.

Bit 02, Coasting stop:

Bit 02 = '0': The frequency converter releases the motor. Bit 02 = '1': The frequency converter starts the motor with a start command.

Bit 03, No error/trip:

Bit 03 = '0' : The frequency converter is not in fault mode. Bit 03 = '1': The frequency converter trips. To re-establish operation, enter [Reset].

Bit 04, No error/error (no trip):

Bit 04 = '0': The frequency converter is not in fault mode. Bit 04 = "1": The frequency converter shows an error but does not trip.

Bit 05, Not used:

Bit 05 is not used in the status word.

\* default setting ( ) display text [ ] value for use in communication via serial communication port

## — How to Programme —

### Bit 06, No error / triplock:

Bit 06 = '0': The frequency converter is not in fault mode. Bit 06 = "1": The frequency converter is tripped and locked.

### Bit 07, No warning/warning:

Bit 07 = '0': There are no warnings. Bit 07 = '1': A warning has occurred.

### Bit 08, Speed ≠ reference/speed = reference:

Bit 08 = '0': The motor is running but the present speed is different from the preset speed reference. It might e.g. be the case when the speed ramps up/down during start/stop. Bit 08 = '1': The motor speed matches the preset speed reference.

### Bit 09, Local operation/bus control:

Bit 09 = '0': [STOP/RESET] is activate on the control unit or Local control in par. 3-13 *Reference Site* is selected. You cannot control the frequency converter via serial communication. Bit 09 = '1' It is possible to control the frequency converter via the fieldbus/ serial communication.

### Bit 10, Out of frequency limit:

Bit 10 = '0': The output frequency has reached the value in par. 4-11 *Motor Speed Low Limit* or par. 4-13 *Motor Speed High Limit*. Bit 10 = "1": The output frequency is within the defined limits.

### Bit 11, No operation/in operation:

Bit 11 = '0': The motor is not running. Bit 11 = '1': The frequency converter has a start signal or the output frequency is greater than 0 Hz.

### Bit 12, Drive OK/stopped, autostart:

Bit 12 = '0': There is no temporary over temperature on the inverter. Bit 12 = '1': The inverter stops because of over temperature but the unit does not trip and will resume operation once the over temperature stops.

### Bit 13, Voltage OK/limit exceeded:

Bit 13 = '0': There are no voltage warnings. Bit 13 = '1': The DC voltage in the frequency converter's intermediate circuit is too low or too high.

### Bit 14, Torque OK/limit exceeded:

Bit 14 = '0': The motor current is lower than the torque limit selected in par. 4-18 *Current Limit*.  
Bit 14 = '1': The torque limit in par. 4-18 *Current Limit* is exceeded.

### Bit 15, Timer OK/limit exceeded:

Bit 15 = '0': The timers for motor thermal protection and VLT thermal protection are not exceeded 100%. Bit 15 = '1': One of the timers exceeds 100%.



— How to Programme —

□ **Control Word according to PROFIdrive Profile (CTW)**

The Control word is used to send commands from a master (e.g. a PC) to a slave.

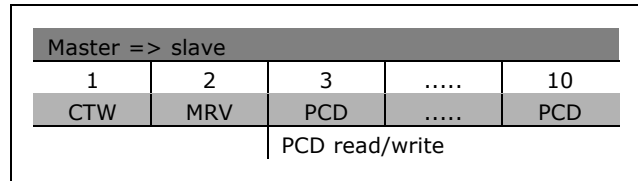

**Explanation of the Control Bits**

Bit	Bit value = 0	Bit value = 1
00	OFF 1	ON 1
01	OFF 2	ON 2
02	OFF 3	ON 3
03	Coasting	No coasting
04	Quick stop	Ramp
05	Hold frequency output.	Use ramp
06	Ramp stop	Start
07	No function	Reset
08	Jog 1 OFF	Jog 1 ON
09	Jog 2 OFF	Jog 2 ON
10	Data invalid	Data valid
11	No function	Slow down
12	No function	Catch up
13	Parameter set-up 1	Selection lsb
14	Parameter set-up 2	Selection msb
15	No function	Reverse

Bit 00, OFF 1/ON 1:

Normal ramp stop uses the ramp times of the actual selected ramp. Bit 00 = "0": Stops and activates the output relay 1 or 2, if the output frequency is 0 Hz and if Relay 123 is selected in par. 5-40. Bit 00 = "1": The frequency converter starts if the other start conditions are met.

Bit 01, OFF 2/ON 2

Bit 01 = "0": Coasting stop and activation of the output relay 1 or 2 occurs if the output frequency is 0 Hz and if Relay 123 is selected in par. 5-40. Bit 01 = "1": The frequency converter starts if the other start conditions are met.

Bit 02, OFF 3/ON 3

A quick stop uses the ramp time of par. 2-12. Bit 02 = "0": A quick stop and activation of the output relay 1 or 2 occurs if the output frequency is 0 Hz and if Relay 123 is selected in par. 5-40. Bit 02 = "1": The frequency converter starts if the other start conditions are met.

Bit 03, Coasting/No coasting

Bit 03 = "0": Leads to a stop. Bit 03 = "1": The frequency converter starts if the other start conditions are met.



**NB!:**

The selection in par. 8-50 *Coasting Select* determines how bit 03 links with the corresponding function of the digital inputs.

\* default setting ( ) display text [ ] value for use in communication via serial communication port

## — How to Programme —

### Bit 04, Quick stop/Ramp

Quick stop uses the ramp time of par. 3-81. Bit 04 = "0": A quick stop occurs. Bit 04 = "1": The frequency converter starts if the other start conditions are met.



**NB!:**

The selection in par. 5-51 *Quick Stop Select* determines how bit 04 links with the corresponding function of the digital inputs.

### Bit 05, Hold frequency output/Use ramp

Bit 05 = "0": Maintains the current output frequency even if the reference value is modified.  
Bit 05 = "1": The frequency converter performs its regulating function again. Operation occurs according to the respective reference value.

### Bit 06, Ramp stop/Start

Normal ramp stop uses the selected ramp times of the actual ramp. In addition, activation of the output relay 01 or 04 if the output frequency is 0 Hz if Relay 123 is selected in par. 5-40. Bit 06 = "0": Leads to a stop. Bit 06 = "1": The frequency converter starts if the other start conditions are met.



**NB!:**

The selection in par. 8-53 determines how bit 06 links with the corresponding function of the digital inputs.

### Bit 07, No function/Reset

Reset after switching off. Acknowledges event in fault buffer. Bit 07 = "0": No reset occurs. A reset occurs after switching off, when there is a slope change of bit 07 to "1".

### Bit 08, Jog 1 OFF/ON

Activation of the pre-programmed speed in par. 8-90 *Bus Jog 1 Speed*. JOG 1 is only possible if bit 04 = "0" and bit 00 - 03 = "1".

### Bit 09, Jog 2 OFF/ON

Activation of the pre-programmed speed in par. 8-91 *Bus Jog 2 Speed*. JOG 2 is only possible if bit 04 = "0" and bit 00 - 03 = "1". If both JOG 1 and JOG 2 are activate (bit 08 and 09 = "1"), JOG 3 is selected. Thus, the speed (set in par. 8-92) is used.

### Bit 10, Data invalid/valid

Notifies the frequency converter if the process data channel (PCD) should respond to modifications by the master (bit 10 = 1) or not.

### Bit 11, No function/Slow down

Reduces the speed reference value by the amount given in par. 3-12 *Catch Up/Slow Down Value*. Bit 11 = "0": The reference value is not modified. Bit 11 = "1": The reference value is reduced.

### Bit 12, No function/Catch up

Increases the speed reference value by the amount given in par. 3-12 *Catch Up/Slow Down Value*. Bit 12 = "0": The reference value is not modified. Bit 12 = "1": The reference value is increased. If both slowing down and accelerating are activate (bit 11 and 12 = "1"), slowing down has priority. Thus, the speed reference value is reduced.

## — How to Programme —

### Bits 13/14, Set-up selection

Choose between the four parameter set-ups via bits 13 and 14 according to the shown table:  
The function is only possible if you choose Multi Set-up in par. 0-10. The selection in par. 8-55 *Set-up Select* determines how bits 13 and 14 links with the corresponding function of the digital inputs. When the motor is running, you can only change the set-up if it is linked.

Set-up	Bit 13	Bit 14
1	0	0
2	1	0
3	0	1
4	1	1

### Bit 15, No function/Reverse

Reversion of the motor rotational direction. Bit 15 = "0": No reversion. Bit 15 = "1": Reversion. The reversion in the default setting in par. 8-54 *Reversing Select* is "Logic OR". Bit 15 causes a reversion only when "Bus", "Logic OR", or "Logic AND" is selected ("Logic AND" only in connection with terminal 9, however).



**NB!:**

Unless otherwise indicated, the control word bit links with the corresponding digital input function as a logic "OR".

— How to Programme —

□ **Status Word According to PROFIdrive**

**Profile (STW)**

The Status word is used to notify a master (e.g. a PC) about the status of a slave.

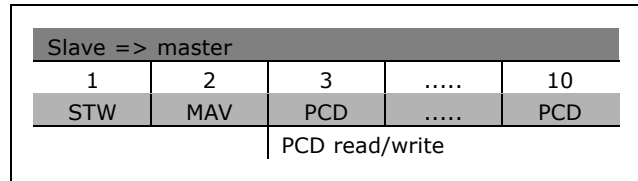

**Explanation of the Status Bits**

Bit	Bit value = 0	Bit value = 1
00	Control not ready	Control ready
01	Drive not ready	Drive ready
02	Coasting	Enable
03	No error	Trip
04	OFF 2	ON 2
05	OFF 3	ON 3
06	Start possible	Start not possible
07	No warning	Warning
08	Speed ≠ reference	Speed = reference
09	Local operation	Bus control
10	Out of frequency limit	Frequency limit
11	No operation	In operation
12	Drive OK	Stopped, autostart
13	Voltage OK	Voltage exceeded
14	Torque OK	Torque exceeded
15	Timer OK	Timer exceeded

Bit 00, Control not ready/ready

Bit 00 = "0": Bit 00, 01, or 02 of the Control word is "0" (OFF 1, OFF 2 or OFF 3) - or the frequency converter switches off (trips). Bit 00 = "1": The frequency converter control is ready but there is not necessarily a power supply (in the event of external 24 V supply of the control system).

Bit 01, VLT not ready/ready

Same significance as bit 00 but with power unit supply. The frequency converter is ready when it receives the necessary start signals.

Bit 02, Coasting/Enable

Bit 02 = "0": Bit 00, 01, or 02 of the Control word is "0" (OFF 1, OFF 2, or OFF 3 or coasting) - or the frequency converter switches off (trips). Bit 02 = "1": Bit 00, 01, or 02 of the Control word is "1" - the frequency converter does not trip.

Bit 03, No error/Trip

Bit 03 = "0": No error in the frequency converter. Bit 03 = "1": The frequency converter trips and requires. Press [Reset] to restart.

Bit 04, ON 2/OFF 2

Bit 04 = "0": Bit 01 of the Control word is "0". Bit 04 = "1": Bit 01 of the Control word is "1".

Bit 05, ON 3/OFF 3

Bit 05 = "0": Bit 02 of the Control word is "0". Bit 05 = "1": Bit 02 of the Control word is "1".

\* default setting ( ) display text [ ] value for use in communication via serial communication port

## — How to Programme —

### Bit 06, Start possible/Start not possible

Bit 06 is always "0" if you select FC Drive in par. 8-10. If you select PROFIdrive in par. 8-10, bit 06 is "1" after a switch-off acknowledgement, after activation of OFF2 or OFF3, and after switching on mains voltage. Start is not possible. The frequency converter is reset with bit 00 of the Control word set to "0" and bit 01, 02, and 10 set to "1".

### Bit 07, No warning/Warning

Bit 07 = "0": No unusual situation. Bit 07 = "1": There is an unusual status in the frequency converter. For more information about warnings - see the *FC 300 Profibus Operating Instructions*.

### Bit 08, Speed ≠ reference / Speed = reference:

Bit 08 = "0": The motor speed deviates from the set speed reference value. This occurs e.g. when the speed is changed during start/stop through ramp up/down. Bit 08 = "1": The motor speed corresponds to the set speed reference value.

### Bit 09, Local operation/Bus control

Bit 09 = "0": Indicates that the frequency converter is stopped via [Stop] or that Local is selected in par. 0-02. Bit 09 = "1": The frequency converter is controlled through the serial interface.

### Bit 10, Out of frequency limit/Frequency limit OK

Bit 10 = "0": The output frequency is outside the limits set in par. 4-11 and par. 4-13 (Warnings: Motor speed low or high limit). Bit 10 = "1": The output frequency is within the indicated limits.

### Bit 11, No operation/Operation

Bit 11 = "0": The motor is not running. Bit 11 = "1": A start signal is active or the output frequency is higher than 0 Hz.

### Bit 12, Drive OK/Stopped, autostart

Bit 12 = "0": No temporary overloading of the inverter. Bit 12 = "1": The inverter stops due to overload. However, the frequency converter is not switched off (trip) and will restart after the overloading stops.

### Bit 13, Voltage OK/Voltage exceeded

Bit 13 = "0": The frequency converter voltage limits are not exceeded. Bit 13 = "1": The direct voltage in the drive intermediate circuit is too low or too high.

### Bit 14, Torque OK/Torque exceeded

Bit 14 = "0": The motor current is below the moment limit selected in par. 4-18. Bit 14 = "1": The torque limit selected in par. 4-18 is exceeded.

### Bit 15, Timer OK/Timer exceeded

Bit 15 = "0": The timers for the thermal motor protection and thermal frequency converter protection have not exceeded 100%. Bit 15 = "1": One of the timers has exceeded 100%.

— How to Programme —

□ **Serial Communication Reference**

The serial communication reference is transferred to the frequency converter as a 16-bit word.  
 The value is transferred in whole numbers  
 0 - ±32767 (±200%).  
 16384 (4000 Hex) corresponds to 100%.

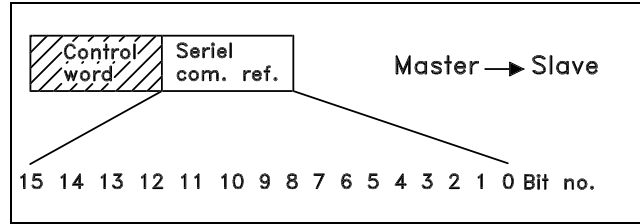

The serial communication reference has the following format: 0-16384 (4000 Hex)  $\cong$  0-100% (par. 3-02 *Minimum Ref.* to par. 3-03 *Maximum Ref.*).

It is possible to change the direction of rotation via the serial reference. This is done by converting the binary reference value to 2' complement. See example.

Example - Control word and serial communication ref.:

The frequency converter receives a start command and the reference is set to 50% (2000 Hex) of the reference range.  
 Control word = 047F Hex => Start command.  
 Reference = 2000 Hex => 50% reference.

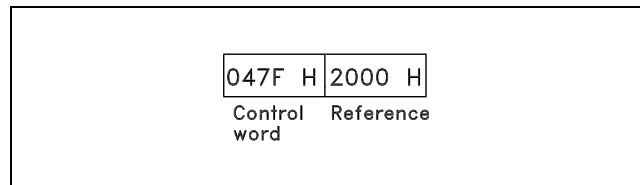

The frequency converter receives a start command and the reference is set to -50% (-2000 Hex) of the reference range.  
 The reference value is first converted to 1' complement, and then 1 is added binarily to obtain 2' complement:

2000 Hex	0010 0000 0000 0000
1' complement	1101 1111 1111 1111
	+ 1
2' complement	1110 0000 0000 0000

Control word = 047F Hex => Start command.  
 Reference = E000 Hex => -50% reference.

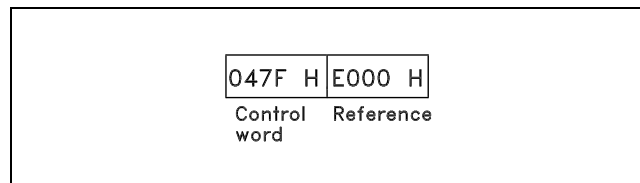

— How to Programme —

□ **Present Output Frequency**

The value of the frequency converter's present output frequency is transferred as a 16-bit word. The value is transferred as whole numbers 0 - ±32767 (±200%).  
16384 (4000 Hex) corresponds to 100%.

Output frequency has this format:  
0-16384 (4000 Hex)  $\cong$  0-100% (Par. 4-12 *Motor Speed Low Limit* - par. 4-14 *Motor Speed High Limit*).

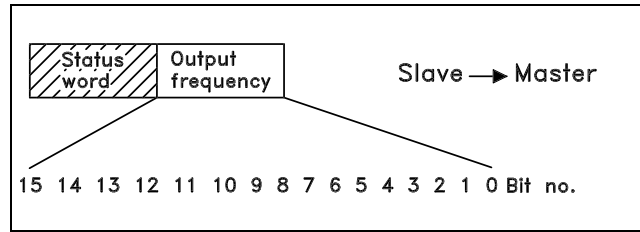

**Example - Status word and current output frequency:**

The frequency converter informs the master that the current output frequency is 50% of the output frequency range.  
Par. 4-12 *Motor Speed Low Limit* = 0 Hz  
Par. 4-14 *Motor Speed High Limit* = 50 Hz

Status word = 0F03 Hex.  
Output frequency = 2000 Hex => 50% of the frequency range, corresponding to 25 Hz.

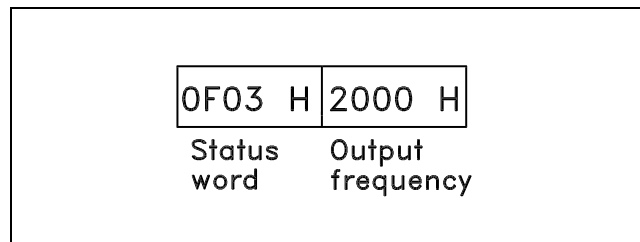

□ **Example 1: For Controlling the Drive and Reading Parameters**

This telegram reads par. 16-14 *Motor Current*.

Telegram to the frequency converter:

stx	lge	adr	pke	ind	pwe, high	pwe, low	pcd 1	pcd 2	bcc
02	0E	01	6 4E	00 00	00 00	00 00	00 00	00 00	45

All numbers are in hex format.

The response from the frequency converter corresponds to the command above but *pwe,high* and *pwe,low* contains the actual value of par. 16-14 multiplied by 100. If the actual output current is 5.24 A, the value from the frequency converter is 524.

Response from the frequency converter:

stx	lge	adr	pke	ind	pwe, high	pwe, low	pcd 1	pcd 2	bcc
02	0E	01	6 4E	00 00	00 00	02 0C	06 07	00 00	4A

All numbers are in hex format.

\* default setting ( ) display text [ ] \* for use in communication via serial communication port

— How to Programme —

*Pcd 1* and *pcd 2* from example 2 can be used and added to the example. Thus, it is possible to control the drive and read the current at the same time.

□ **Example 2: Only for Controlling the Drive**

This telegram sets the control word to 047C Hex (Start command) with a speed reference of 2000 Hex (50%).



**NB!:**  
Par. 8-10 is set to FC Profile.

Telegram to the frequency converter:  
All numbers are in hex format.

stx	lge	adr	pcd 1	pcd 2	bcc
02	06	04	04 7C	20 00	58

The frequency converter supplies information about the drive status after receiving the command. By resending the command, the *pcd1* changes to a new status.

Response from the frequency converter:  
All numbers are in hex format.

stx	lge	adr	pcd 1	pcd 2	bcc
02	06	04	06 07	00 00	01

□ **Read Parameter Description Elements**

Read the characteristics of a parameter (eg. *Name, Default value, conversion, etc.*) with *Read Parameter Description Elements*.

The table shows the available parameter description elements:

Index	Description
1	Basic characteristics
2	No of elements (array types)
4	Unit of measure
6	Name
7	Lower limit
8	Upper limit
20	Default value
21	Additional characteristics

In the following example *Read Parameter Description Elements* is chosen in par. 0-01 *Language*, and the requested element is index 1 *Basic characteristics*.

**Basis characteristics (index 1):**

The Basic characteristics command is split up in two parts representing basic behaviour and datatype. The Basic characteristics return a 16 bit value to the master in  $PWE_{LOW}$ .

The basic behaviour indicates whether eg. text is available or the parameter is an array as single bit information in the high byte of  $PWE_{LOW}$ .

The datatype part indicates if a parameter is signed 16, unsigned 32 in the low byte of  $PWE_{LOW}$ .

\* default setting ( ) display text [ ] value for use in communication via serial communication port



— How to Programme —

PWE high basic behaviour:

Bit	Description
15	Active parameter
14	Array
13	Parameter value can only be reset
12	Parameter value different from factory setting
11	Text available
10	Additional text available
9	Read only
8	Upper and lower limit not relevant
0-7	Data type

*Active parameter* is only active when communicating through Profibus.

*Array* means that the parameter is an array.

If bit 13 is true, the parameter can only be reset, not written to.

If bit 12 is true, the parameter value is different from the factory setting.

Bit 11 indicates that text is available.

Bit 10 indicates that additional text is available. Eg. par. 0-01, *Language*, contains text for index field 0, *English*, and for index field 1, *German*.

If bit 9 is true, the parameter value is read-only and cannot be changed.

If bit 8 is true, upper and lower limits of the parameter value are not relevant.

PWE<sub>LOW</sub> datatype

Dec.	Data type
3	Signed 16
4	Signed 32
5	Unsigned 8
6	Unsigned 16
7	Unsigned 32
9	Visible string
10	Byte string
13	Time difference
33	Reserved
35	Bit sequence

**Example**

In this example, the master reads the Basic characteristics of par. 0-01, *Language*. The following telegram must be sent to the frequency converter:

STX	LGE	ADR	PKE	IND	PWE <sub>HIGH</sub>	PWE <sub>LOW</sub>	PCD1	PCD2	BCC
02	0E	01	40 01	00 01	00 00	00 00	XX XX	XX XX	XX

\* default setting ( ) display text [ ] value for use in communication via serial communication port

— How to Programme —

- STX = 02 Start byte
- LGE = 0E Length of remaining telegram
- ADR = Sends the frequency converter on Address 1, Danfoss format
- PKE = 4001; 4 in the PKE field indicates a *Read Parameter Description* and 01 indicates par. 0-01, *Language*
- IND = 0001; 1 indicates that *Basic characteristics* are required.

The response from the frequency converter is:

STX	LGE	ADR	PKE	IND	PWE <sub>HIGH</sub>	PWE <sub>LOW</sub>	PCD1	PCD2	BCC
02	0E	01	30 01	00 01	00 00	04 05	XX XX	XX XX	XX

- STX= 02 Start byte
- IND = 0001; 1 indicates that *Basic characteristics* are sent
- PKE = 3001: 3 in the PKE field indicates *Parameter Description Element Transferred*, 01 indicates par. 0-01.
- PWE<sub>LOW</sub> = 0405; 04 indicates that Basic behaviour as bit 10 corresponds to *Additional text*. 05 is the datatype which corresponds to *Unsigned 8*.

**No of elements (index 2):**

This function indicates the Number of elements (array) of a parameter. The answer to the master will be in PWE<sub>LOW</sub>.

**Conversion and Unit of measurement (index 4):**

The Conversion and unit of measurement command indicates the conversion of a parameter and the unit of measurement. The answer to the master is in PWE<sub>LOW</sub>. The conversion index is in the high byte of PWE<sub>LOW</sub> and the unit index is in the low byte of PWE<sub>LOW</sub>. Conversion index is signed 8 and unit index is unsigned 8, see the tables.

Conversion index	Conversion factor
0	1
1	10
2	100
3	1000
-1	0.1
-2	0.01
-3	0.001
67	1/60
74	3600
75	3600000
100	1

The unit index defines the "Unit of measure". The conversion index defines how the value should be scaled to get the basic representation of the "Unit of measure". Basic representation is where conversion index equals "0".

Example:

A parameter has a "unit index" of 9 and a "conversion index" of 2. The raw (integer) value read is 23. This means that we have a parameter of the unit "Power" and the raw value should be multiplied by 10 to the power of 2 and the unit is W.  $23 \times 10^2 = 2300 \text{ W}$

\* default setting ( ) display text [ ] value for use in communication via serial communication port

— How to Programme —

Unit index	Unit of measure	Designation	Conversion index
0	Dimension less		0
4	Time	s	0
		h	74
8	Energy	j	0
		kWh	
9	Power	W	0
		kW	3
11	Speed	1/s	0
		1/min (RPM)	67
16	Torque	Nm	0
17	Temperature	K	0
		°C	100
21	Voltage	V	0
22	Current	A	0
24	Ratio	%	0
27	Relative change	%	0
28	Frequency	Hz	0
54	Time difference w/o date indication	ms	1*

\*

Bit	8	7	6	5	4	3	2	1	
Byte 1	2 <sup>31</sup>	2 <sup>30</sup>	2 <sup>29</sup>	2 <sup>28</sup>	2 <sup>27</sup>	2 <sup>26</sup>	2 <sup>25</sup>	2 <sup>24</sup>	ms
Byte 2	2 <sup>23</sup>	2 <sup>22</sup>	2 <sup>21</sup>	2 <sup>20</sup>	2 <sup>19</sup>	2 <sup>18</sup>	2 <sup>17</sup>	2 <sup>16</sup>	
Byte 3	2 <sup>15</sup>	2 <sup>14</sup>	2 <sup>13</sup>	2 <sup>12</sup>	2 <sup>11</sup>	2 <sup>10</sup>	2 <sup>9</sup>	2 <sup>8</sup>	
Byte 4	2 <sup>7</sup>	2 <sup>6</sup>	2 <sup>5</sup>	2 <sup>4</sup>	2 <sup>3</sup>	2 <sup>2</sup>	2 <sup>1</sup>	2 <sup>0</sup>	

**Name (index 6):**

The Name returns a string value in ASCII format, containing the name of the parameter.

**Example:**

In this example the master reads the name of par. 0-01, *Language*.

The following telegram must be sent to the frequency converter:

STX	LGE	ADR	PKE	IND	PWE <sub>HIGH</sub>	PWE <sub>LOW</sub>	PCD1	PCD2	BCC
02	0E	01	40 01	00 06	00 00	00 00	XX XX	XX XX	XX

- STX = 02 Start byte
- LGE = 0E Length of remaining telegram
- ADR = Sends the frequency converter on Address 1, Danfoss format
- PKE = 4001; 4 in the PKE field indicates a *Read Parameter Description* and 01 indicates par. 0-01, *Language*
- IND = 0006; 6 indicates that *Names* is required.

— How to Programme —

The response from the frequency converter will be:

STX	LGE	ADR	PKE	IND	PVA	PCD1	PCD2	BCC
02	12	01	30 01	00 06	4C41 4E47 5541 4745	XXXX	XXXX	XX

PKE = 3001; 3 are the response for *Name* and 01 indicates the par. 0-01, *Language*  
 IND = 00 06; 06 indicates that *Name* is sent.  
 PVA = 4C 41 4E 47 55 41 47 45  
 L A N G U A G E

The parameter value channel is now set up to a visible string which returns an ASCII character for each letter in the parameter name.

**Lower limit (index 7):**

The Lower limit returns the minimum allowed value of a parameter. The data type of Lower limit is the same as for the parameter itself.

**Upper limit (index 8):**

The Upper limit returns the maximum allowed value of a parameter. The data type of Upper limit is the same as for the parameter itself.

**Default value (index 20):**

The Default value returns the default value of a parameter, which is the factory setting. The data type of Default value is the same as for the parameter itself.

**Additional characteristics (index 21):**

The command can be used for getting additional information on a parameter, eg. *No bus Access, Power Unit dependency, etc.*. The Additional characteristics returns an answer in PWE<sub>LOW</sub>. If a bit is logic '1', the condition is true according to the table below:

Bit	Description
0	Special Default Value
1	Special Upper Limit
2	Special Lower Limit
7	LCP Access LSB
8	LCP Access MSB
9	NoBusAccess
10	Std Bus Read Only
11	Profibus Read Only
13	ChangeRunning
15	PowerUnitDependency

If one of bit 0 *Special Default Value*, bit 1 *Special Upper Limit* and bit 2 *Special Lower Limit* are true, the parameter has power unit depending values.

Bit 7 and 8 indicates the attributes for the LCP access, see table.

Bit 8	Bit 7	Description
0	0	No access
0	1	Read only
1	0	Read/write
1	1	Write with lock

Bit 9 indicates *No bus Access*.

Bits 10 and 11 indicates that this parameter can only be read over the bus.

\* default setting ( ) display text [ ] value for use in communication via serial communication port

— How to Programme —

If bit 13 is true, the parameter cannot be changed while running.  
 If bit 15 is true, the parameter is depending on the power unit.

□ **Additional Text**

With this feature it is possible to read additional text if bit 10, *Additional text available*, is true in Basic characteristics.

To read out additional text, the parameter command (PKE) must be set to F hex, see *Databytes*.

The index-field is used for pointing out which element to read. Valid indexes are in the range of 1 through 254. The index must be calculated after the following equation:  
 Index = Parameter value + 1 (see table below).

Value	Index	Text
0	1	English
1	2	Deutsch
2	3	Français
3	4	Dansk
4	5	Espanol
5	6	Italiano

**Example:**

In this example, the Master reads additional text in par. 0-01, *Language*. The telegram is set up to read data value [0] (*English*). You must send the following telegram to the frequency converter:

STX	LGE	ADR	PKE	IND	PWE <sub>HIGH</sub>	PWE <sub>LOW</sub>	PCD1	PCD2	BCC
02	0E	01	F0 01	00 01	00 00	00 00	XX XX	XX XX	XX

- STX = 02 Start byte
- LGE = 0E Length of the remaining telegram
- ADR = Send the VLT frequency converter on Address 1, Danfoss format
- PKE = F001; F in the PKE field indicates a *Read text* and 01 indicates par. 0-01, *Language*.
- IND = 0001; 1 indicates that text to parameter value [0] is required

The response from the frequency converter is:

STX	LGE	ADR	PKE	IND	PVA	PCD1	PCD2	BCC
02	11	01	F0 01	00 01	454E 474C 4953 48	XX XX	XX XX	XX

- PKE = F001; F is the response for *Text transfer* and 01 indicates par. 0-01, *Language*.
- IND = 0001; 1 indicates that index [1] is sent
- PVA = 45 4E 47 4C 49 53 48  
 E N G L I S H

The parameter value channel is now set up to a visible string, which returns an ASCII character for each letter in the index name.

\* default setting ( ) display text [ ] value for use in communication via serial communication port

\* default setting   ( ) display text   [ ] value for use in communication via serial communication port

## Troubleshooting

### □ Warnings/Alarm Messages

A warning or an alarm is signalled by the relevant LED on the front of the frequency converter and indicated by a code on the display.

A warning remains active until its cause is no longer present. Under certain circumstances operation of the motor may still be continued. Warning messages may be critical, but are not necessarily so.

In the event of an alarm, the frequency converter will have tripped. Alarms must be reset to restart operation once their cause has been rectified. This may be done in three ways:

1. By using the [RESET] control button on the LCP control panel.
2. Via a digital input with the "Reset" function.
3. Via serial communication/optional fieldbus.



#### **NB!:**

After a manual reset using the [RESET] button on the LCP, the [AUTO ON] button must be pressed to restart the motor.

If an alarm cannot be reset, the reason may be that its cause has not been rectified, or the alarm is trip-locked (see also table on following page).

Alarms that are trip-locked offer additional protection, meaning that the mains supply must be switched off before the alarm can be reset. After being switched back on, the FC 300 is no longer blocked and may be reset as described above once the cause has been rectified.

Alarms that are not trip-locked can also be reset using the automatic reset function in parameters 14-20 (Warning: automatic wake-up is possible!)

If a warning and alarm is marked against a code in the table on the following page, this means that either a warning occurs before an alarm, or else that you can specify whether it is a warning or an alarm that is to be displayed for a given fault.

This is possible, for instance, in parameters 1-90 *Motor Thermal Protection*. After an alarm or trip, the motor carries on coasting, and the alarm and warning flash on the FC 300. Once the problem has been rectified, only the alarm continues flashing.

— Troubleshooting —

<b>Alarm/Warning code list</b>					
No.	Description	Warning	Alarm/Trip	Alarm/Trip Lock	Parameter Reference
1	10 Volts low	X			
2	Live zero error	(X)	(X)		6-01
3	No motor	(X)			1-80
4	Mains phase loss	(X)	(X)	(X)	14-12
5	DC link voltage high	X			
6	DC link voltage low	X			
7	DC over voltage	X	X		
8	DC under voltage	X	X		
9	Inverter overloaded	X	X		
10	Motor ETR over temperature	(X)	(X)		1-90
11	Motor thermistor over temperature	(X)	(X)		1-90
12	Torque limit	X	X		
13	Over Current	X	X	X	
14	Earth fault	X	X	X	
15	Hardware mesh mash		X	X	
16	Short Circuit		X	X	
17	Control word timeout	(X)	(X)		8-04
25	Brake resistor short-circuited	X			
26	Brake resistor power limit	(X)	(X)		2-13
27	Brake chopper short-circuited	X	X		
28	Brake check	(X)	(X)		2-15
29	Power board over temp	X	X	X	
30	Motor phase U missing	(X)	(X)	(X)	4-58
31	Motor phase V missing	(X)	(X)	(X)	4-58
32	Motor phase W missing	(X)	(X)	(X)	4-58
33	Inrush fault		X	X	
34	Fieldbus communication fault	X	X		
38	Internal fault		X	X	
47	24 V supply low	X	X	X	
48	1.8 V supply low		X	X	
49	Speed limit	X			
50	AMA calibration failed		X		
51	AMA check $U_{nom}$ and $I_{nom}$		X		
52	AMA low $I_{nom}$		X		
53	AMA motor too big		X		
54	AMA motor too small		X		
55	AMA parameter out of range		X		
56	AMA interrupted by user		X		
57	AMA timeout		X		
58	AMA internal fault	X	X		
59	Current limit	X			
61	Tracking Error	(X)	(X)		4-30
62	Output Frequency at Maximum Limit	X			
63	Mechanical Brake Low		(X)		2-20
64	Voltage Limit	X			
65	Control Board Over-temperature	X	X	X	
66	Heat sink Temperature Low	X			
67	Option Configuration has Changed		X		
68	Safe Stop Activated		X		
80	Drive Initialised to Default Value		X		
90	Encoder Loss	(X)	(X)		17-61

(X) Dependent on parameter

<i>LED indication</i>	
Warning	yellow
Alarm	flashing red
Trip locked	yellow and red



## — Troubleshooting —

**Description of Alarm Word, Warning Word and extended Status Word**

Alarm Word Extended Status Word					
Bit	Hex	Dec	AlarmWord	WarningWord	ExtendedStatusWord
0	00000001	1	Brake Check	Brake Check	Ramping
1	00000002	2	Pwr. Card Temp	Pwr. Card Temp	AMA Running
2	00000004	4	Earth Fault	Earth Fault	Start CW/CCW
3	00000008	8	Ctrl.Card Temp	Ctrl.Card Temp	Slow Down
4	00000010	16	Ctrl. Word TO	Ctrl. Word TO	Catch Up
5	00000020	32	Over Current	Over Current	Feedback High
6	00000040	64	Torque Limit	Torque Limit	Feedback Low
7	00000080	128	Motor Th Over	Motor Th Over	Output Current High
8	00000100	256	Motor ETR Over	Motor ETR Over	Output Current Low
9	00000200	512	Inverter Overld.	Inverter Overld.	Output Freq High
10	00000400	1024	DC under Volt	DC under Volt	Output Freq Low
11	00000800	2048	DC over Volt	DC over Volt	Brake Check OK
12	00001000	4096	Short Circuit	DC Voltage Low	Braking Max
13	00002000	8192	Inrush Fault	DC Voltage High	Braking
14	00004000	16384	Mains ph. Loss	Mains ph. Loss	Out of Speed Range
15	00008000	32768	AMA Not OK	No Motor	OVC Active
16	00010000	65536	Live Zero Error	Live Zero Error	
17	00020000	131072	Internal Fault	10V Low	
18	00040000	262144	Brake Overload	Brake Overload	
19	00080000	524288	U phase Loss	Brake Resistor	
20	00100000	1048576	V phase Loss	Brake IGBT	
21	00200000	2097152	W phase Loss	Speed Limit	
22	00400000	4194304	Fieldbus Fault	Fieldbus Fault	
23	00800000	8388608	24 V Supply Low	24V Supply Low	
24	01000000	16777216	Mains Failure	Mains Failure	
25	02000000	33554432	1.8V Supply Low	Current Limit	
26	04000000	67108864	Brake Resistor	Low Temp	
27	08000000	134217728	Brake IGBT	Voltage Limit	
28	10000000	268435456	Option Change	Unused	
29	20000000	536870912	Drive Initialised	Unused	
30	40000000	1073741824	Safe Stop	Unused	
31	80000000	2147483648	Mech. brake low	Extended Status Word	

The alarm words, warning words and extended status words can be read out via serial bus or optional fieldbus for diagnose. See also par. 16-90, 16-92 and 16-94.

**WARNING 1****10 Volts low:**

The 10 V voltage from terminal 50 on the control card is below 10 V.

Remove some of the load from terminal 50, as the 10 V supply is overloaded. Max. 15 mA or minimum 590 Ω.

**WARNING/ALARM 2****Live zero error:**

The signal on terminal 53 or 54 is less than 50% of the value set in par. 6-10, 6-12, 6-20, or 6-22 respectively.

**WARNING/ALARM 3****No motor:**

No motor has been connected to the output of the frequency converter.

**WARNING/ALARM 4****Mains phase loss:**

A phase is missing on the supply side, or the mains voltage imbalance is too high.

This message also appears in case of a fault in the input rectifier on the frequency converter.

Check the supply voltage and supply currents to the frequency converter.

— Troubleshooting —

**WARNING 5**

**DC link voltage high:**

The intermediate circuit voltage (DC) is higher than the overvoltage limit of the control system. The frequency converter is still active.

**WARNING 6**

**DC link voltage low**

The intermediate circuit voltage (DC) is below the undervoltage limit of the control system. The frequency converter is still active.

**WARNING/ALARM 7**

**DC over voltage:**

If the intermediate circuit voltage exceeds the limit, the frequency converter trips after a time.

Possible corrections:

- Select **Over Voltage Control** function in par. 2-17
- Connect a brake resistor
- Extend the ramp time
- Activate functions in par. 2-10
- Increase par. 14-26

Selecting OVC function will extend the ramp times.

**WARNING/ALARM 8**

**DC under voltage:**

If the intermediate circuit voltage (DC) drops below the "voltage warning low" limit (see table above), the frequency converter checks if 24 V backup supply is connected.

If no 24 V backup supply is connected, the frequency converter trips after a given time depending on the unit.

To check whether the supply voltage matches the frequency converter, see *General Specifications*.

**WARNING/ALARM 9**

**Inverter overloaded:**

The frequency converter is about to cut out because of an overload (too high current for too long). The counter for electronic, thermal inverter protection gives a warning at 98% and trips at 100%, while giving an alarm. You cannot reset the frequency converter until the counter is below 90%.

The fault is that the frequency converter is overloaded by more than nominal current for too long.

**WARNING/ALARM 10**

**Motor ETR over temperature:**

According to the electronic thermal protection (ETR), the motor is too hot. You can choose if you want the frequency converter to give a warning or an alarm when the counter reaches 100% in par. 1-90. The fault is that the motor is overloaded by more than nominal current for too long. Check that the motor par. 1-24 is set correctly.

**WARNING/ALARM 11**

**Motor thermistor over temp:**

The thermistor or the thermistor connection is disconnected. You can choose if you want the frequency converter to give a warning or an alarm in par. 1-90. Check that the thermistor is connected correctly between terminal 53 or 54 (analog voltage input) and terminal 50 (+ 10 Volts supply), or between terminal 18 or 19 (digital input PNP only) and terminal 50. If a KTY sensor is used, check for correct connection between terminal 54 and 55.

**WARNING/ALARM 12**

**Torque limit:**

The torque is higher than the value in par. 4-16 (in motor operation) or the torque is higher than the value in par. 4-17 (in regenerative operation).

**WARNING/ALARM 13**

**Over Current:**

The inverter peak current limit (approx. 200% of the rated current) is exceeded. The warning

Alarm/warning limits:			
FC 301 Series	3 x 200- 240 V AC [VDC]	3 x 380- 500 V AC [VDC]	3 x 525- 600 V AC [VDC]
Undervoltage			
Voltage warning low			
Voltage warning high (w/o brake - w/brake)			
Overvoltage			
FC 302 Series	3 x 200- 240 V AC [VDC]	3 x 380- 500 V AC [VDC]	3 x 525- 600 V AC [VDC]
Undervoltage	185	373	532
Voltage warning low	205	410	585
Voltage warning high (w/o brake - w/brake)	390/405	810/840	943/965
Overvoltage	410	855	975

The voltages stated are the intermediate circuit voltage of the FC 300 with a tolerance of ± 5 %. The corresponding mains voltage is the intermediate circuit voltage (DC-link) divided by 1.35

## — Troubleshooting —

will last approx. 8-12 sec., then the frequency converter trips and issues an alarm. Turn off the frequency converter and check if the motor shaft can be turned and if the motor size matches the frequency converter.

### **ALARM 14**

#### **Earth fault:**

There is a discharge from the output phases to earth, either in the cable between the frequency converter and the motor or in the motor itself. Turn off the frequency converter and remove the earth fault.

### **ALARM 15**

#### **In-complete hardware:**

A fitted option is not handled by the present control board (hardware or software).

### **ALARM 16**

#### **Short-circuit:**

There is short-circuiting in the motor or on the motor terminals. Turn off the frequency converter and remove the short-circuit.

### **WARNING/ALARM 17**

#### **Control word timeout:**

There is no communication to the frequency converter. The warning will only be active when par. 8-04 is NOT set to *OFF*. If par. 8-04 is set to *Stop* and *Trip*, a warning appears and the frequency converter ramps down to zero speed, while giving an alarm. Par. 8-03 *Control Word Timeout Time* could possibly be increased.

### **WARNING 25**

#### **Brake resistor short-circuited:**

The brake resistor is monitored during operation. If it short-circuits, the brake function is disconnected and the warning appears. The frequency converter still works, but without the brake function. Turn off the frequency converter and replace the brake resistor (see par. 2-15 *Brake Check*).

### **ALARM/WARNING 26**

#### **Brake resistor power limit:**

The power transmitted to the brake resistor is calculated as a percentage, as a mean value over the last 120 s, on the basis of the resistance value of the brake resistor (par. 2-11) and the intermediate circuit voltage. The warning is active when the dissipated braking power is higher than 90%. If *Trip* [2] has been selected in par. 2-13, the frequency

converter cuts out and issues this alarm, when the dissipated braking power is higher than 100%.

### **WARNING/ALARM 27**

#### **Brake chopper fault:**

The brake transistor is monitored during operation and if it short-circuits, the brake function disconnects and the warning comes up. The frequency converter is still able to run, but since the brake transistor has short-circuited, substantial power is transmitted to the brake resistor, even if it is inactive. Turn off the frequency converter and remove the brake resistor.



Warning: There is a risk of substantial power being transmitted to the brake resistor if the brake transistor is short-circuited.

### **ALARM/WARNING 28**

#### **Brake check failed:**

Brake resistor fault: the brake resistor is not connected/working.

### **WARNING/ALARM 29**

#### **Drive over temperature:**

If the enclosure is IP 20 or IP 21/TYPE 1, the cut-out temperature of the heat-sink is 95 °C ±5 °C. The temperature fault cannot be reset, until the temperature of the heatsink is below 70 °C. The fault could be:

- Ambient temperature too high
- Too long motor cable

### **ALARM 30**

#### **Motor phase U missing:**

Motor phase U between the frequency converter and the motor is missing. Turn off the frequency converter and check motor phase U.

### **ALARM 31**

#### **Motor phase V missing:**

Motor phase V between the frequency converter and the motor is missing. Turn off the frequency converter and check motor phase V.

### **ALARM 32**

#### **Motor phase W missing:**

Motor phase W between the frequency converter and the motor is missing. Turn off the frequency converter and check motor phase W.

— Troubleshooting —

**ALARM 33****Inrush fault:**

Too many powerups have occurred within a short time period. See the chapter *General Specifications* for the allowed number of powerups within one minute.

**WARNING/ALARM 34****Fieldbus communication fault:**

The fieldbus on the communication option card is not working.

**ALARM 38****Internal fault:**

Contact your Danfoss supplier.  
Some typical alarm messages:

- 1299 - OptionSW in slot A is too old
- 1300 - OptionSW in slot B is too old
- 1301 - OptionSW in slot C0 is too old
- 1302 - OptionSW in slot C1 is too old
- 1315 - Option SW in slot A is not supported (not allowed)
- 1316 - Option SW in slot B is not supported (not allowed)
- 1317 - Option SW in slot C0 is not supported (not allowed)
- 1318 - Option SW in slot C1 is not supported (not allowed)
- 2315 - Missing SW version from power unit.

**WARNING 47****24 V supply low:**

The external 24 V DC backup power supply may be overloaded, otherwise contact your Danfoss supplier.

**ALARM 48****1.8 V supply low:**

Contact your Danfoss supplier.

**WARNING 49****Speed limit:**

The speed has been limited by range in par. 4-11 and par. 4-13.

**ALARM 50****AMA calibration failed:**

Contact your Danfoss supplier.

**ALARM 51****AMA check Unom and Inom:**

The setting of motor voltage, motor current, and motor power is presumably wrong. Check the settings.

**ALARM 52****AMA low Inom:**

The motor current is too low. Check the settings.

**ALARM 53****AMA motor too big:**

The motor is too big for the AMA to be carried out.

**ALARM 54****AMA motor too small:**

The motor is too small for the AMA to be carried out.

**ALARM 55****AMA par. out of range:**

The par. values found from the motor are outside acceptable range.

**ALARM 56****AMA interrupted by user:**

The AMA has been interrupted by the user.

**ALARM 57****AMA timeout:**

Try to start the AMA again a number of times, until the AMA is carried out. Please note that repeated runs may heat the motor to a level where the resistance  $R_s$  and  $R_r$  are increased. In most cases, however, this is not critical.

**WARNING/ALARM 58****AMA internal fault:**

Contact your Danfoss supplier.

**WARNING 59****Current limit:**

The current is higher than the value in par. 4-18.

**WARNING/ALARM 61****Tracking Error:**

The difference between set speed and actual speed exceed the value set in par. 4-31. Disable the function in par. 4-30. Check motor parameters 1-00 to 1-40.

**WARNING 62****Output Frequency at Maximum Limit:**

The output frequency is limited by the value set in par. 4-19

**ALARM 63****Mechanical Brake Low:**

The actual motor current has not exceeded the "release brake" current within the "Start delay" time window.

**WARNING 64****Voltage Limit:**

The load and speed combination demands a motor voltage higher than the actual DC link voltage.

**WARNING/ALARM/TRIP 65****Control Card Over Temperature:**

## — Troubleshooting —

Control card over temperature: The cut-out temperature of the control card is 80° C.

**WARNING 66****Heatsink Temperature Low:**

The heat sink temperature is measured as 0° C. This could indicate that the temperature sensor is defective and thus the fan speed is increased to the maximum in case the power part or control card is very hot.

**ALARM 67****Option Configuration has Changed:**

One or more options has either been added or removed since the last power-down.

**ALARM 68****Safe Stop Activated:**

Safe Stop has been activated. To resume normal operation, apply 24 V DC to terminal 37, then send a reset signal (via Bus, Digital I/O, or by pressing [RESET]).  
Only possible in FC 301 with A1 enclosure.

**ALARM 70****Illegal Frequency Configuration:**

Actual combination of control board and power board is illegal.

**ALARM 80****Drive Initialised to Default Value:**

Parameter settings are initialised to default setting after a manual (three-finger) reset or via par. 14-22.



## Index

### A

Abbreviations .....	6
Access to Control Terminals .....	99
Access to Quick Menu w/o Password .....	147
Accessory Bag .....	89
Acoustic Noise .....	64
Active Set-up .....	142
Additional characteristics .....	284
Additional Text .....	285
Address .....	261, 262
ADR .....	261
Aggressive Environments .....	15
Air Humidity .....	15
Alarm Messages .....	287
Alarm word .....	200
AMA .....	121
Analog input .....	8
Analog Inputs .....	8, 60
Analog output .....	61
Automatic Motor Adaptation .....	121
Automatic Motor Adaptation (AMA) .....	103, 150

### B

Back EMF at 1000 RPM .....	152
Basic characteristics .....	280
Basic Wiring Example .....	100
Baud Rate .....	139, 262
Brake Check .....	162
Brake Connection Option .....	107
Brake Current .....	163
Brake Function .....	48
Brake power .....	9, 48, 162, 162
Brake Power Monitoring .....	162
Brake Resistor .....	46
Brake resistors .....	78
Braking Time .....	269
Break-away torque .....	8
Bus Jog 2 Speed .....	203

### C

cable clamps .....	112
control cables .....	112
Cable clamp .....	115
Cable lengths and cross sections .....	58
Catch up .....	181
Catch up / slow down .....	24
Catch up/slow Down Value .....	166, 274
Changing a Group of Numeric Data Values .....	134

Changing a Text Value .....	133
Changing Data .....	133
Changing of Data Value .....	135
Clockwise .....	156, 156, 174, 189, 240
Clockwise rotation .....	110
Coast .....	156
Coasting .....	7, 128, 201, 269, 271, 273, 276
Coasting stop .....	273
Communication option .....	292
Configuration Mode .....	148
Connection to Mains .....	92
Control Cables .....	101, 102
Control card performance .....	62
Control card, +10 V DC output .....	62
Control card, 24 V DC output .....	61
Control card, RS 485 serial communication .....	61
Control card, USB serial communication .....	62
Control characteristics .....	62
Control Terminals .....	99, 100
Control Word .....	268, 273
Control Word Timeout Function .....	199
Conversion and unit of measurement .....	282
Cooling .....	65, 91, 158
Counter clockwise .....	174
Current Lim Cont, Proportional Gain .....	226

### D

direction of motor rotation .....	110
D-axis Inductance (Ld) .....	152
Data Character (byte) .....	263
DC brake .....	156, 161, 202, 269
DC Braking Time .....	161
DC hold .....	156, 156, 157, 161
DC link .....	290
DC Link Voltage .....	234
Dead Band .....	26
Dead Band Around Zero .....	25
Decoupling plate .....	94
Default Settings .....	139, 241
Default value .....	284
Definitions .....	6
Derating for Ambient Temperature .....	65
Derating for Low Air Pressure .....	65
Derating for Running at Low Speed .....	65
DeviceNet .....	5, 83
Digital inputs: .....	58
Digital output .....	61
Display line 1.3 Small .....	145
Display line 2 large .....	146

## — Index —

Display Mode .....	130
Display Mode - Selection of Read-Outs .....	130
Disposal Instruction .....	13
Drive Configurator .....	81

**E**

Earth connection .....	92
Earth Leakage Current .....	45, 112
earthing .....	115
Earthing of Screened/Armoured Control Cables .....	115
Efficiency .....	63
Electrical Installation .....	96, 100, 101
Electrical Installation - EMC Precautions .....	112
Electrical terminals .....	101
Electro-mechanical brake.....	120
Electronic Terminal Relay .....	159
EMC Test Results .....	41
Encoder feedback.....	16
Encoder Positive Direction.....	240
Encoder pulses .....	189
Encoder Signal Monitoring .....	240
End-of-Timeout Function .....	200
Equalising cable, .....	115
ETR.....	109, 158, 234, 290
Ext. Status Word.....	238
External 24 V DC supply.....	77
External Reference .....	235
Extreme Running Conditions.....	51

**F**

Fault Log: Error Code .....	230
Fault Log: Time .....	231
Fault Log: Value.....	230
FC Profile .....	268
Flux .....	19, 20
Flying Start .....	156
Freeze output.....	7, 269
Freeze reference .....	24
Freq. Input #29 [Hz] .....	236
Freq. Input #33 [Hz] .....	236
Frequency .....	233, 279
Function at Stop .....	157
Fuses.....	97

**G**

Galvanic Isolation (PELV).....	44
General warning .....	5
Graphical display.....	125

**H**

Harmonic filters .....	86
Heatsink Temp.....	234
High Voltage Test .....	112

**I**

Incremental encoder .....	235
Indexed Parameters .....	135
Indicator lights .....	126
Infinitely Variable Change of Numeric Data Value.....	134
Initialisation .....	139
Intermediate circuit .....	48, 51, 64, 64, 107, 290
Internal Current Control in VVC+ Mode.....	20
Iron Loss Resistance (Rfe) .....	152
IT mains.....	227

**J**

Jog .....	7, 269, 274
Jog Ramp Time.....	172
Jog Speed .....	166
Jog Speed [RPM].....	167

**K**

KTY sensor .....	290
KWh Counter .....	228

**L**

Local Control Panel .....	125
Lower limit .....	284
Language.....	141
LC filter .....	79, 95
LC Filters .....	79
LCP .....	7, 9, 21, 78, 129, 136
LCP 102.....	125
LCP Copy .....	147
LCP Id No .....	231
Leakage Current .....	45
LEDs .....	125
Load Sharing .....	107
Load Type .....	155
Local (Hand On) and Remote (Auto On) Control .....	21
Local Control Keys .....	137
Local reference.....	141

**M**

Mechanical dimensions .....	67
motor name plate.....	103



## — Index —

Main Menu .....	131
Main Menu mode.....	126, 132
Main reactance .....	150
Main Reactance (Xh) .....	151
Mains plug connector.....	92
Mains RFI Filter circuit .....	227
Mains supply.....	11, 53, 57
Mains supply (L1, L2, L3).....	58
Mains Supply Interference .....	116
Max Output Frequency.....	175
Maximum Inertia.....	155
Maximum Limit.....	173
Maximum Reference.....	165
Mechanical Brake .....	49
Mechanical Dimensions .....	67
Mechanical mounting.....	91
Min Speed for Function at Stop [Hz].....	157
Min Speed for Function at Stop [RPM] .....	157
Minimum Inertia .....	155
Minimum Limit .....	173
Missing Motor Phase Function .....	177, 178
Moment of inertia.....	51
Motor Angle Offset.....	152
Motor Cables.....	96
Motor cables .....	112
Motor Connection .....	94
Motor Cont. Rated Torque.....	150
Motor Current .....	150
Motor Feedback .....	20, 148
Motor Frequency .....	149
Motor Nominal Speed .....	150
Motor output.....	58
Motor parameters.....	121
Motor phases .....	51
Motor Poles .....	152
Motor Power [HP] .....	149
Motor Power [kW] .....	149
Motor protection .....	58, 109, 158
Motor Rotation .....	110
Motor Speed Unit .....	141
Motor Thermal Protection .....	51, 110, 158, 272
Motor voltage.....	64, 149, 233

**N**

Name .....	283
Name plate data .....	103, 103
Non UL compliance .....	97
Normal torque.....	149
Number of elements.....	282
Numerical Local Control Panel .....	136

**O**

Operating Hours .....	228
Operating mode.....	141
Operating State at Power-up (Hand) .....	141
Operation Mode .....	225
Ordering Form Type Code .....	81
Ordering numbers .....	81
Ordering Numbers: Brake Resistors .....	83
Ordering Numbers: Harmonic Filters.....	86
Ordering Numbers: LC Filter Modules.....	86
Ordering Numbers: Options and Accessories .....	83
Output performance (U, V, W).....	58
Output speed .....	156
Over-voltage Control .....	163

**P**

Parameter Selection .....	133
Parameter Set-Up.....	131
Passive load.....	155
Peak Voltage.....	64
PLC .....	115
Potentiometer Reference .....	117
Power Factor .....	11
Power Restore .....	173
Power Up's .....	228
Pre-magnetizing .....	157
Precise Stop .....	157
Precise Stop Counter .....	237
Precise Stop Function .....	157
Preset Reference.....	166
Preset Reference Select.....	202
Process PID Control .....	34
Profibus.....	5, 83
Profibus Warning Word.....	207
PROFIdrive Profile .....	273
Programming of Torque Limit and Stop .....	120
ProportionalGain .....	196
Protection .....	15, 44, 45, 97
Protection and Features .....	58
Protocols .....	261
Pulse Reference .....	235
Pulse Start/Stop .....	117
Pulse/encoder inputs .....	60

**Q**

Quick Menu .....	126, 126, 131
Quick Menu mode.....	126, 131
Quick Menu Password .....	147
Quick Stop Ramp Time.....	172
Quick Stop Select .....	201
Quick Transfer of Parameter Settings .....	129

## — Index —

**R**

Ramp 1 Ramp Down Time	168
Ramp 1 Ramp up Time	168
Ramp 1 Type	168
Ramp 2 Ramp down Time	169
Ramp 3 Ramp down Time	170
Ramp 3 Ramp up Time	170
Ramp 4 Ramp Down Time	171
Ramp Delay	173
Ramp Time	173
Rated motor speed	7
RCD	10, 45
Read Parameter Description Elements	280
Reference Handling	24
Reference Resource 1	167
Regional Settings	141
Relative Scaling Reference Resource	167
Relay Connection	108
Relay outputs	61, 183
Removal of Knockouts for Extra Cables	92
Reset	128
Reset Control Word Timeout	200
Reset kWh Counter	228
Reset Mode	224
Residual Current Device	45
Rise time	64
Rotor Leakage Reactance (X2)	151
Rotor Resistance (Rr)	151

**S**

screened/armoured	102
Step-by-Step	135
Safe Stop	52, 117
Safe Stop Installation	105
Safety Eart Connection	112
Scaling of References and Feedback	25
Serial communication	8, 62, 115, 278
Side-by-side installation	91
Smart Logic Control	50
Software versions	83
Speed PID	16, 18
Speed PID Control	30
Speed PID Lowpass Filter Time	196
Start Delay	155, 156
Start Function	156, 156
Start Speed [Hz]	156
Start Speed [RPM]	156
Start/Stop	117
Stator leakage reactance	150
Stator Leakage Reactance (X1)	151
Stator Resistance (Rs)	151
Status	126
Status messages	125

Status Word	271, 276
Step Size	173
Surroundings	62
Switches S201, S202, and S801	102
Switching Frequency	224

**T**

Telegram Structure	261
Telegram Traffic	261
Temperature-Dependent Switch Frequency	66
Term 32/33 Encoder Direction	189
Term. 29 Low Frequency	186
Terminal 37	52
Terminal 53 High Current	192
Terminal 53 Low Current	192
Terminal 54 High Current	192
Terminal 54 Low Current	192
Thermal load	152, 234
Thermistor	10, 158
This Set-Up Linked to	142
Torque characteristics	58
Torque control	16
Torque Limit Generator Mode	175
Trip Delay at Torque Limit	226

**U**

Upper limit	284
USB Connection	99, 99
Use of EMC-Correct Cables	114

**V**

Variable torque	148
Vibration and Shock	16
Voltage level	59
VVC <sup>plus</sup>	10, 18, 148

**W**

Warning Word	238
Warnings	287

**2**

24 V encoder	148
--------------	-----

**[**

[Reset] Key on LCP	146
--------------------	-----