

■ Contents

Introduction	3
Software version	3
Safety regulations	4
Warning against unintended start	4
Introduction	6
Available literature	7
Technology	8
How to select your frequency converter	12
Normal/high overload torque mode	12
Ordering form VLT 5000 Series - Typecode	16
Selection of modules and accessories	18
PC Software tools	18
Product range	20
Accessories for VLT 5000 Series	21
Technical data	31
General technical data	31
Electrical data	38
Fuses	55
Measurements, dimensions	58
Mechanical dimensions	58
Mechanical installation	61
Mechanical installation	61
Electrical installation	64
Safety earthing	64
Extra protection (RCD)	64
Electrical installation - mains supply	64
Electrical installation - motor cables	64
Connection of motor	65
Direction of motor rotation	65
Electrical installation - brake cable	66
Electrical installation - brake resistor temperature switch	66
Electrical installation - loadsharing	66
Electrical installation - 24 Volt external DC supply	68
Electrical installation - relay outputs	68
Electrical installation - control cables	76
Electrical installation - bus connection	78
Electrical installation - EMC precautions	79
Use of emc-correct cables	82
Electrical installation - earthing of control cables	83
RFI switch	84

Serial communication	87
Control Word According to FC Profile	92
Status Word according to FC Profile	94
Control word according to Fieldbus Profile	95
Status word according to Fieldbus Profile	96
Telegram example	99
Connection example	104
Conveyor belt	104
Pump	105
Gantry Crane	106
Torque control, speed feedback	107
VLT 5000 controllers	108
PID for process control	110
PID for speed control	111
PID for torque controller (open loop)	112
Special conditions	113
Galvanic Isolation (PELV)	113
Extreme Running Conditions	114
Peak voltage on motor	115
Switching on the input	117
Derating	118
Motor thermal protection	121
Vibration and Shock	121
Air Humidity	121
Aggressive environments	122
Efficiency	123
CE labelling	125
Required compliance levels	129
EMC Immunity	129
Definitions	132
Factory settings	135
Index	144

■ Software version

VLT 5000 Series

Design Guide Software version: 3.7x



This Design Guide can be used for all VLT 5000 Series frequency converters with software version 3.7x.

The software version number can be seen from parameter 624.
CE and C-tick labelling do not cover VLT 5001-5062,
525-600 V units.

175ZA456.18

Introduction



The voltage of the frequency converter is dangerous whenever the equipment is connected to mains. Incorrect installation of the motor or the frequency converter may cause damage to the equipment, serious personal injury or death. Consequently, the instructions in this manual, as well as national and local rules and safety regulations, must be complied with.

■ Safety regulations

1. The frequency converter must be disconnected from mains if repair work is to be carried out. Check that the mains supply has been disconnected and that the necessary time has passed before removing motor and mains plugs.
2. The [STOP/RESET] key on the control panel of the frequency converter does not disconnect the equipment from mains and is thus not to be used as a safety switch.
3. Correct protective earthing of the equipment must be established, the user must be protected against supply voltage, and the motor must be protected against overload in accordance with applicable national and local regulations.
4. The earth leakage currents are higher than 3.5 mA.
5. Protection against motor overload is not included in the factory setting. If this function is desired, set parameter 128 to data value *ETR trip* or data value *ETR warning*.
Note: The function is initialised at 1.16 x rated motor current and rated motor frequency. For the North American market: The ETR functions provide class 20 motor overload protection in accordance with NEC.
6. Do not remove the plugs for the motor and main supply while the frequency converter is connected to mains. Check that the mains supply has been disconnected and that the necessary time has expired before removing motor and mains plugs.
7. Please note that the frequency converter has more voltage inputs than L1, L2 and L3, when loadsharing (linking of DC intermediate circuit) and external 24 V DC have been installed. Check that all voltage inputs have been disconnected and that the necessary time has passed before repair work is commenced.

■ Warning against unintended start

1. The motor can be brought to a stop by means of digital commands, bus commands, references or a local stop, while the frequency converter is connected to mains.
If personal safety considerations make it necessary to ensure that no unintended start occurs, these stop functions are not sufficient.
2. While parameters are being changed, the motor may start. Consequently, the stop key [STOP/RESET] must always be activated, following which data can be modified.
3. A motor that has been stopped may start if faults occur in the electronics of the frequency converter, or if a temporary overload or a fault in the supply mains or the motor connection ceases.

■ Use on isolated mains

See section *RFI Switch* regarding use on isolated mains.

It is important to follow the recommendations regarding installation on IT-mains, since sufficient protection of the complete installation must be observed. Not taking care using relevant monitoring devices for IT-mains may result in damage.



Warning:

Touching the electrical parts may be fatal - even after the equipment has been disconnected from mains.

Also make sure that other voltage inputs have been disconnected, such as external 24 V DC, load-sharing (linkage of DC intermediate circuit), as well as the motor connection for kinetic back-up.

Using VLT 5001-5006, 200-240 V:	wait at least 4 minutes
Using VLT 5008-5052, 200-240 V:	wait at least 15 minutes
Using VLT 5001-5006, 380-500 V:	wait at least 4 minutes
Using VLT 5008-5062, 380-500 V:	wait at least 15 minutes
Using VLT 5072-5302, 380-500 V:	wait at least 20 minutes
Using VLT 5352-5552, 380-500 V:	wait at least 40 minutes
Using VLT 5001-5005, 525-600 V:	wait at least 4 minutes
Using VLT 5006-5022, 525-600 V:	wait at least 15 minutes
Using VLT 5027-5062, 525-600 V:	wait at least 30 minutes
Using VLT 5042-5352, 525-690 V:	wait at least 20 minutes
Using VLT 5402-5602, 525-690 V:	wait at least 30 minutes

175ZA439.21

Introduction

■ Introduction

This Design Guide is intended as a tool for use when designing a plant or system that includes VLT 5000 Series. Specific technical publications on the VLT 5000 Series: Operating Instructions and Design Guide.

Operating Instructions: Gives instructions in optimum installation, commissioning and service.

Design Guide: Gives all required information for design purposes, and gives a good insight into the technology, product range, technical data, etc.

The Operating Instructions include a Quick Setup instruction and are delivered with the unit.

When reading through this Design Guide, you will come across various symbols that require special attention.

The symbols used are the following:



Indicates a general warning



NB!:

Indicates something to be noted by the reader



Indicates a high-voltage warning

■ Available literature

Below is a list of the literature available for VLT 5000. It must be noted that there may be deviations from one country to another.

Supplied with the unit:

Operating instructions	MG.51.AX.YY
High Power Installation Guide	MI.90.JX.YY

Communication with VLT 5000:

VLT 5000 Profibus manual	MG.10.EX.YY
VLT 5000 DeviceNet manual	MG.50.HX.YY
VLT 5000 LonWorks manual	MG.50.MX.YY
VLT 5000 Modbus manual	MG.10.MX.YY
VLT 5000 Interbus manual	MG.10.OX.YY

Application options for VLT 5000:

VLT 5000 SyncPos option manual	MG.10.EX.YY
VLT 5000 Positioning controller manual	MG.50.PX.YY
VLT 5000 Synchronising controller manual	MG.10.NX.YY
Ring spinning option	MI.50.ZX.02
Wobble function option	MI.50.JX.02
Winder and Tension control option	MG.50.KX.02

Instructions for VLT 5000:

Loadsharing	MI.50.NX.02
VLT 5000 Brake resistors	MI.90.FX.YY
Brake resistors for horizontal applications (VLT 5001 - 5011) (Only in English and German)	MI.50.SX.YY
LC filter modules	MI.56.DX.YY
Converter for encoder inputs (5V TTL to 24 V DC) (Only in combined English/German)	MI.50.IX.51
Back Plate to VLT 5000 Series	MN.50.XX.02

Various literature for VLT 5000:

Design Guide	MG.51.BX.YY
Incorporating a VLT 5000 Profibus in a Simatic S5 system	MC.50.CX.02
Incorporating a VLT 5000 Profibus in a Simatic S7 system	MC.50.AX.02
Hoist and the VLT 5000 series	MN.50.RX.02

Miscellaneous (only in English):

Protection against electrical hazards	MN.90.GX.02
Choice of prefuses	MN.50.OX.02
VLT on IT mains	MN.90.CX.02
Filtering of harmonic currents	MN.90.FX.02
Handling aggressive environments	MN.90.IX.02
CI-TI™ contactors - VLT® frequency converters	MN.90.KX.02
VLT® frequency converters and UniOP operator panels	MN.90.HX.02

X = version number
YY = language version

■ Control principle

A frequency converter rectifies AC voltage from mains into DC voltage, after which this DC voltage is converted into a AC current with a variable amplitude and frequency.

The motor is thus supplied with variable voltage and frequency, which enables infinitely variable speed control of three-phased, standard AC motors.

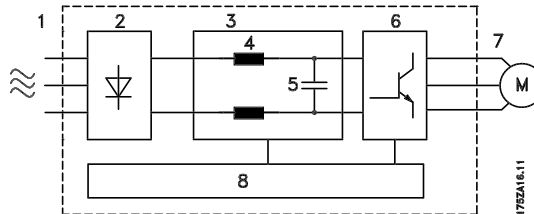

1. Mains voltage

3 x 200 - 240 V AC, 50 / 60 Hz.
 3 x 380 - 500 V AC, 50 / 60 Hz.
 3 x 525 - 600 V AC, 50 / 60 Hz.
 3 X 525 - 690 V AC, 50 / 60 Hz.

2. Rectifier

A three-phase rectifier bridge that rectifies AC current into DC current.

3. Intermediate circuit

DC voltage = 1.35 x mains voltage [V].

4. Intermediate circuit coils

Smooth the intermediate circuit current and limit the load on mains and components (mains transformer, wires, fuses and contactors).

5. Intermediate circuit capacitors

Smooth the intermediate circuit voltage.

6. Inverter

Converts DC voltage into variable AC voltage with a variable frequency.

7. Motor voltage

Variable AC voltage, 0-100% of mains supply voltage.
 Variable frequency: 0.5-132/0.5-1000 Hz.

8. Control card

This is where to find the computer that controls the inverter which generates the pulse pattern by which the DC voltage is converted into variable AC voltage with a variable frequency.

VVC^{plus} control principle

The frequency converter features an inverter control system called VVC^{plus}, which is a further development of the Voltage Vector Control (VVC) known i.e. from Danfoss VLT 3000 Series.

VVC^{plus} controls an induction motor by energizing it with a variable frequency and a voltage that matches it. If the motor load is changed, the magnetisation of the motor changes too, and so does its speed. Consequently, the motor current is measured continuously and the actual voltage requirement and slip of the motor are calculated from a motor model. Motor frequency and voltage are adjusted to ensure that the motor operating point remains optimum under varying conditions.

The development of the VVC^{plus} principle is the result of a wish to maintain robust, sensorless regulation that is tolerant to different motor characteristics without motor derating being required.

First and foremost, the current measurement and the motor model have been improved. The current is split into magnetising and torque-generating parts and provides for much better and quicker estimation of the actual motor loads. It is now possible to compensate for rapid load changes. Full torque as well as extremely accurate speed control can now be obtained even at low speeds or even at standstill.

In a "special motor mode", permanent magnet synchronous motors and/or parallel motors can be used.

Good torque control properties, smooth transitions to and from current limit operation and robust pull-out torque protection are ensured.

After automatic motor adaptation, VVC^{plus} will help to ensure extremely accurate motor control.

Advantages of the VVC^{plus} control system:

- Accurate speed control, now even at low speed
- Quick response from received signal to full motor shaft torque
- Good compensation for step loads
- Controlled transition from normal operation to current limit operation (and vice versa)
- Reliable pull-out torque protection throughout the speed range, also in the case of field weakening
- Great tolerance towards varying motor data
- Torque control, comprising control of both the torque-generating and the magnetising component of the current
- Full holding torque (closed loop)

As standard, the frequency converter comes with a number of integral components that would normally have to be acquired separately. These integral components (RFI filter, DC coils, screen clamps and serial communication port) are space-savers that simplify installation, since the frequency converter fulfills most requirements without any supplementary components.

Programmable control inputs and signal outputs in four Setups

The frequency converter uses a digital technique which makes it possible to program the different control inputs and signal outputs and to select four different user-defined Setups for all parameters.

For the user, it is easy to program the desired functions by means of the control panel on the frequency converter or the RS 485 user interface.

Protection against mains interference

The frequency converter is protected against the transients that occur in the mains supply, e.g. when switching power factor correction or when fuses blow.

The rated motor voltage and full torque can be maintained all the way down to 10% undervoltage in the mains supply.

Minor interference on mains

Since as standard the frequency converter features intermediate circuit coils, there is only a small amount of harmonic mains supply interference. This ensures a good power factor and lower peak current, which reduces the load on the mains installation.

Advanced VLT protection

Current measurement on all three motor phases provides perfect protection of the frequency converter against earthing and short-circuiting faults on the motor connection.

Constant monitoring of all three motor phases enables switching on the motor output, e.g. by means of a contactor.

Efficient monitoring of the three mains supply phases ensures that the unit stops in the case of phase failure. This avoids overloading the inverter and the capacitors in the intermediate circuit, which would dramatically reduce the service life of the frequency converter.

As standard, the frequency converter features integral thermal protection. If a situation of thermal overload occurs, this function cuts out the inverter.

Reliable galvanic isolation

In the frequency converter, all control terminals as well as terminals 1-5 (AUX relays) are supplied by or connected to circuits that comply with PELV requirements in relation to the mains potential.

Advanced motor protection

The frequency converter features integrated electronic, thermal motor protection.

The frequency converter calculates the motor temperature on the basis of current, frequency and time.

As opposed to the traditional bimetallic protection, electronic protection takes account of the reduction in cooling at low frequencies that comes from reduced fan speed (motors with internal ventilation).

Thermal motor protection is comparable to a normal motor thermistor.

To obtain maximum protection against overheating of the motor if the motor is covered or blocked, or if the fan fails, a thermistor can be integrated and connected to the thermistor input of the frequency converter (terminals 53/54), see parameter 128 of the Operating Instructions.

■ Key Diagram for VLT 5001–5027
200-240 V, VLT 5001–5102 380-500V,
VLT 5001–5062 525-600 V

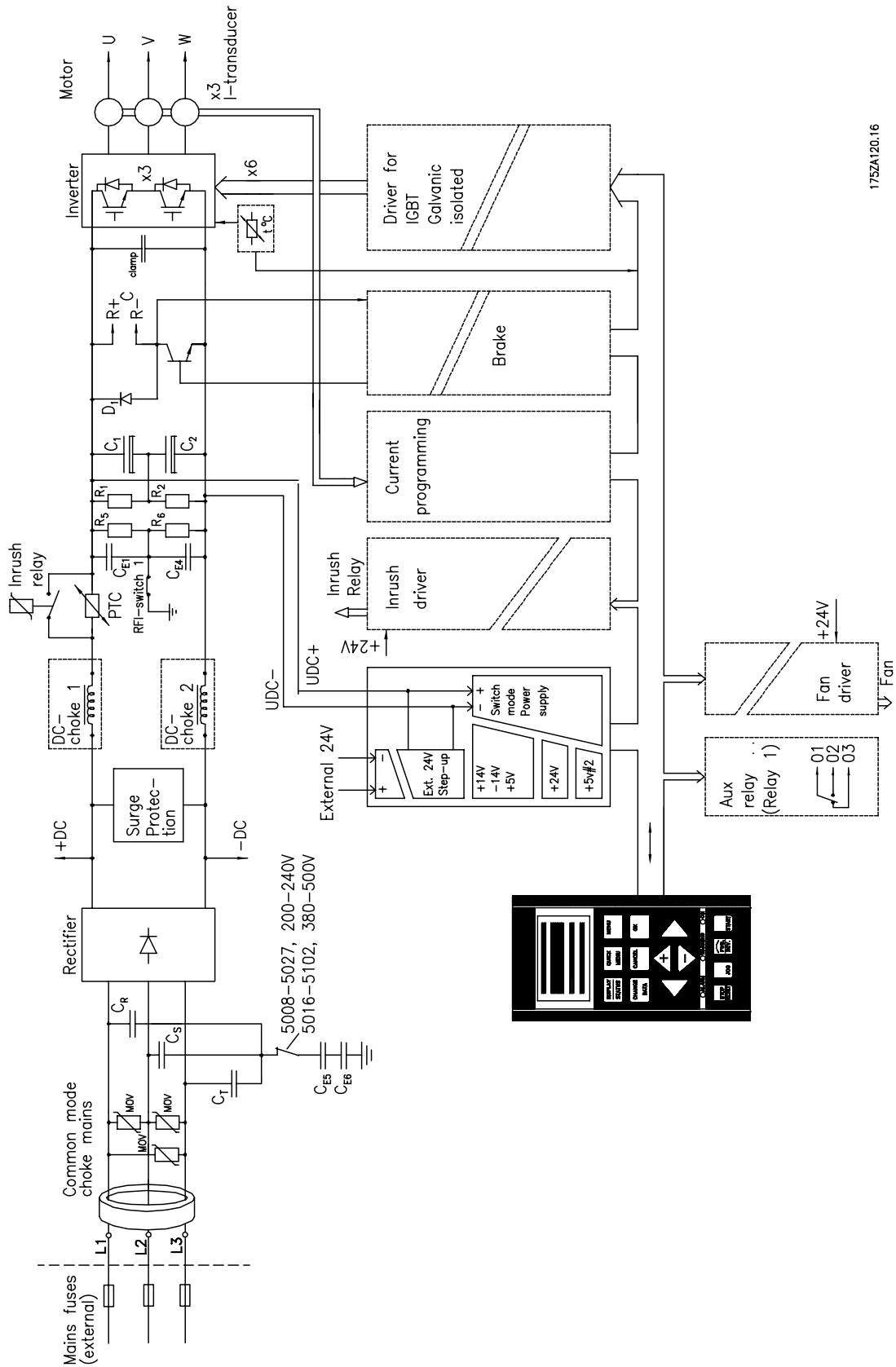

175ZA120.16

■ Key Diagram for VLT 5122-5552 380-500 V and VLT 5042-5602 525-690 V

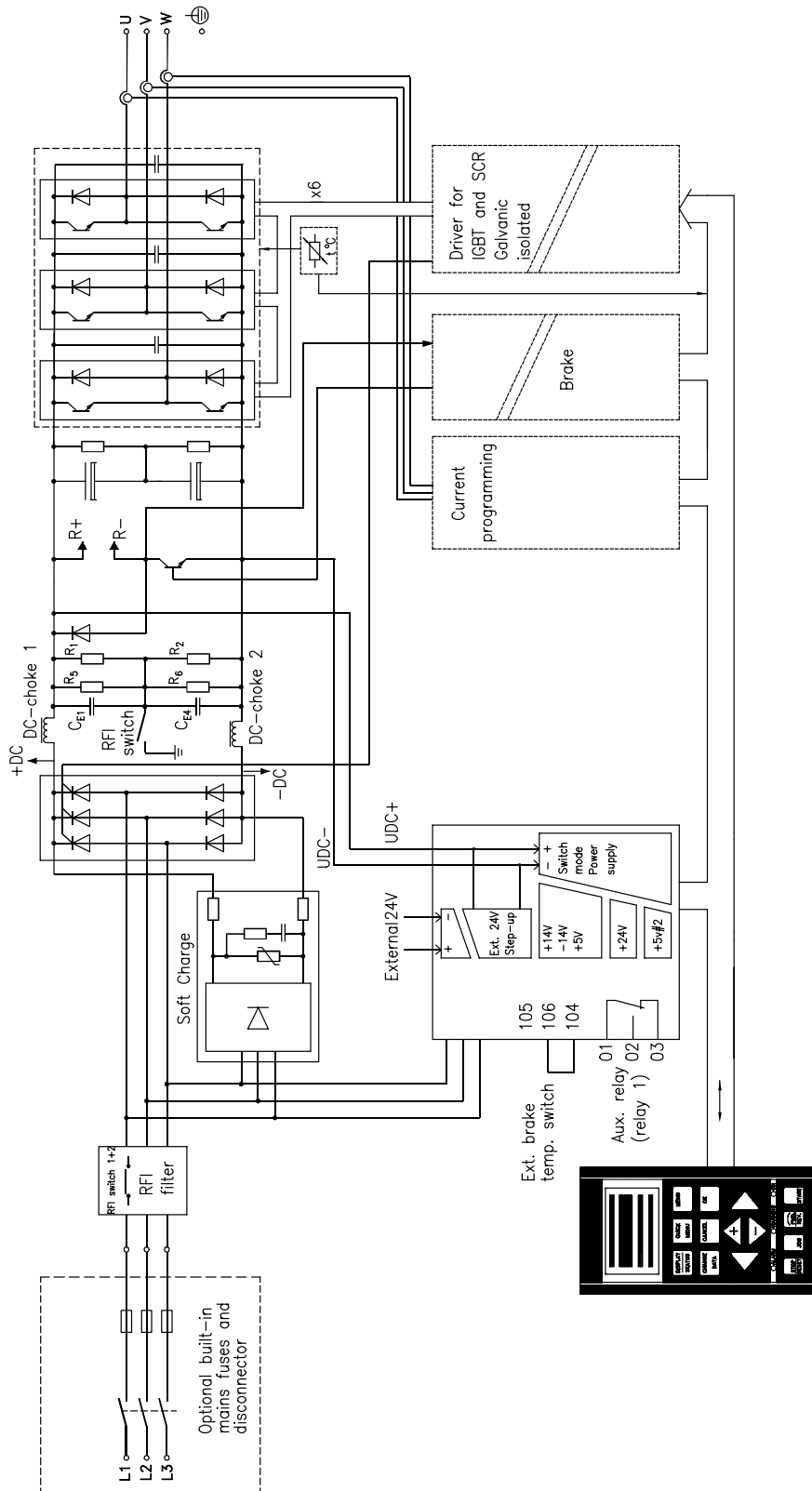

1752A699.10

Technology

Note: The RFI switch has no function in the 525-690 V drives.

■ How to select your frequency converter

A frequency converter must be selected on the basis of the given motor current at maximum load on the unit. The rated output current $I_{VLT,N}$ must be equal to or higher than the required motor current.

The frequency converter is supplied for four mains voltage ranges: 200-240 V, 380-500 V, 525-600 V and 525-690 V.

■ Normal/high overload torque mode

This function enables the frequency converter to perform a constant 100% torque, using an oversize motor. The choice between a normal or a high overload torque characteristic is made in parameter 101.

This is also where to choose between a high/normal constant torque characteristic (CT) or a high/normal VT torque characteristic.

If a *high torque characteristic* is chosen, a rated motor with the frequency converter obtains up to 160% torque for 1 min. in both CT and VT.

If a *normal torque characteristic* is chosen, an oversize motor allows up to 110% torque performance for up to 1 min. in both CT and VT. This function is used mainly for pumps and fans, since these applications do not require an overload torque.

The advantage of choosing a normal torque characteristic for an oversize motor is that the frequency converter will be able constantly to yield 100% torque, without derating as a result of a bigger motor.



NB!:

This function cannot be chosen for VLT 5001-5006, 200-240 Volts, and VLT 5001-5011, 380-500 Volts.

■ Type code ordering number string

The VLT 5000 series frequency converter is offered in a large number of variants. On the basis of your order, the frequency converter is given an ordering number that can be seen from the nameplate on the unit. The number may look as follows:

VLT5008PT5B20EBR3DLF10A10C0

This means that the frequency converter is configured as a:

- 5,5 kW unit at 160% torque (Position 1-7 - VLT 5008)
- Process control card (Position 8 - P)
- 380-500 V three phase supply (Position 9-10 - T5)
- Bookstyle IP20 enclosure (Position 11-13 - B20)
- Extended hardware version with brake (Position 14-15 - EB)
- Built in RFI filter (Position 16-17 - R3)
- Supplied with display (Position 18-19 - DL)
- Built in Profibus option (Position 20-22 - F10)
- Built in programmable SyncPos controller (Position 23-25 - A10)
- Uncoated printed circuit boards (Position 26-27 - C0)

Variants and options possible

In the following you will find an overview of possible variants that can be put together. Please refer to the description of the designation below.

VLT 5001-5052, 200-240 V units

Typecode designation: T2

Powersize (kW)		Type	Enclosure					HW variant			RFI filter		
Torque 110% 160%			C00	B20	C20	CN1	C54	ST	SB	EB	R0	R1	R3
		9-10	11-13	11-13	11-13	11-13	11-13	14-15	14-15	14-15	16-17	16-17	16-17
0.75		5001		x	x		x	x	x				x
1.1		5002		x	x		x	x	x				x
1.5		5003		x	x		x	x	x				x
2.2		5004		x	x		x	x	x				x
3		5005		x	x		x	x	x				x
3.7		5006		x	x		x	x	x			x	
7.5	5.5	5008			x		x	x	x		x		x
11	7.5	5011			x		x	x	x		x		x
15	11	5016			x		x	x	x		x		x
18.5	15	5022			x		x	x	x		x		x
22	18.5	5027			x		x	x	x		x		x
30	22	5032	x				x	x	x		x	x	
37	30	5042	x				x	x	x		x	x	
45	37	5052	x				x	x	x		x	x	

C00	Compact IP00	DE	Extended with brake, disconnect and fuses
B20	Bookstyle IP20	DX	Extended without brake, with disconnect and fuses
C20	Compact IP20	PS	Standard with 24 V supply
CN1	Compact Nema1	PB	Standard with 24 V supply, brake, fuse and disconnect
C54	Compact IP54	PD	Standard with 24 V supply, fuse and disconnect
ST	Standard	PF	Standard with 24 V supply and fuse
SB	Standard with brake	R0	Without filter
EB	Extended with brake	R1	Class A1 filter
EX	Extended without brake	R3	Class A1 and B filter

VLT 5001-5552, 380-500 V units
Typecode designation: T5

Power size (kW)	Type	Enclosure				HW variant								RFL filter						
		C00	B20	CN1	C54	ST	SB	EB	EX	DE	DX	PS	PB	PD	PF	R0	R1	R3	R6	
110%	9-10	11-13	11-13	11-13	11-13	14-15	14-15	14-15	14-15	14-15	14-15	14-15	14-15	14-15	16-17	16-17	16-17	16-17	16-17	
Torque	160%																			
0.75	5001	X	X	X	X	X	X	X	X	X	X	X	X	X	X	X	X	X	X	X
1.1	5002	X	X	X	X	X	X	X	X	X	X	X	X	X	X	X	X	X	X	X
1.5	5003	X	X	X	X	X	X	X	X	X	X	X	X	X	X	X	X	X	X	X
2.2	5004	X	X	X	X	X	X	X	X	X	X	X	X	X	X	X	X	X	X	X
3	5005	X	X	X	X	X	X	X	X	X	X	X	X	X	X	X	X	X	X	X
3.7	5006	X	X	X	X	X	X	X	X	X	X	X	X	X	X	X	X	X	X	X
5.5	5008	X	X	X	X	X	X	X	X	X	X	X	X	X	X	X	X	X	X	X
7.5	5011	X	X	X	X	X	X	X	X	X	X	X	X	X	X	X	X	X	X	X
15	5016	X	X	X	X	X	X	X	X	X	X	X	X	X	X	X	X	X	X	X
18.5	5022	X	X	X	X	X	X	X	X	X	X	X	X	X	X	X	X	X	X	X
22	5027	X	X	X	X	X	X	X	X	X	X	X	X	X	X	X	X	X	X	X
30	5032	X	X	X	X	X	X	X	X	X	X	X	X	X	X	X	X	X	X	X
37	5042	X	X	X	X	X	X	X	X	X	X	X	X	X	X	X	X	X	X	X
45	5052	X	X	X	X	X	X	X	X	X	X	X	X	X	X	X	X	X	X	X
55	5062	X	X	X	X	X	X	X	X	X	X	X	X	X	X	X	X	X	X	X
75	5072	X	X	X	X	X	X	X	X	X	X	X	X	X	X	X	X	X	X	X
90	5102	X	X	X	X	X	X	X	X	X	X	X	X	X	X	X	X	X	X	X
110	5122	X	X	X	X	X	X	X	X	X	X	X	X	X	X	X	X	X	X	X
132	5152	X	X	X	X	X	X	X	X	X	X	X	X	X	X	X	X	X	X	X
160	5202	X	X	X	X	X	X	X	X	X	X	X	X	X	X	X	X	X	X	X
200	5252	X	X	X	X	X	X	X	X	X	X	X	X	X	X	X	X	X	X	X
250	5302	X	X	X	X	X	X	X	X	X	X	X	X	X	X	X	X	X	X	X
315	5352	X	X	X	X	X	X	X	X	X	X	X	X	X	X	X	X	X	X	X
355	5452	X	X	X	X	X	X	X	X	X	X	X	X	X	X	X	X	X	X	X
400	5502	X	X	X	X	X	X	X	X	X	X	X	X	X	X	X	X	X	X	X
450	5552	X	X	X	X	X	X	X	X	X	X	X	X	X	X	X	X	X	X	X

C00 Compact IP00
 B20 Bookstyle IP20
 C20 Compact IP20
 CN1 Compact Nema1
 C54 Compact IP54
 ST Standard
 SB Standard with brake
 EB Extended with brake
 EX Extended without brake
 DE Extended with brake, disconnect and fuses
 DX Extended without brake, with disconnect and fuses
 PS Standard with 24 V supply
 PB Standard with 24 V supply, brake, fuse and disconnect
 PD Standard with 24 V supply, fuse and disconnect
 PF Standard with 24 V supply and fuse
 R0 Without filter
 R1 Class A1 filter
 R3 Class A1 and B filter
 R6 Filter for marine installations

VLT 5001-5062, 525-600 V units

Typecode designation: T6

Powersize (kW)		Type	Enclosure			HW variant		RFI filter
Torque 110% 160%			C00 11-13	C20 11-13	CN1 11-13	ST 14-15	EB 14-15	R0 16-17
1.1	0.75	5001		x		x	x	x
1.5	1.1	5002		x		x	x	x
2.2	1.5	5003		x		x	x	x
3.0	2.2	5004		x		x	x	x
4.0	3.0	5005		x		x	x	x
5.5	4.0	5006		x		x	x	x
7.5	5.5	5008		x		x	x	x
7.5	7.5	5011		x		x	x	x
15	11	5016		x		x	x	x
18.5	15	5022		x		x	x	x
22	18.5	5027		x		x	x	x
30	22	5032		x		x	x	x
37	30	5042		x		x	x	x
45	37	5052		x		x	x	x
55	45	5062		x		x	x	x

VLT 5042-5602, 525-690 V units

Typecode designation: T7

Power size (kW)		Type	Enclosure			Hardware variant										RFI filter	
Torque 110% 160%			C00 11-13	CN1 11-13	C54 11-13	ST 14-15	SB 14-15	EB 14-15	EX 14-15	DE 14-15	DX 14-15	PS 14-15	PB 14-15	PD 14-15	PF 14-15	R0 16-17	R1 ¹ 16-17
45	37	5042	X	X	X	X	X	X	X	X	X	X	X	X	X	X	X
55	45	5052	X	X	X	X	X	X	X	X	X	X	X	X	X	X	X
75	55	5062	X	X	X	X	X	X	X	X	X	X	X	X	X	X	X
90	75	5072	X	X	X	X	X	X	X	X	X	X	X	X	X	X	X
110	90	5102	X	X	X	X	X	X	X	X	X	X	X	X	X	X	X
132	110	5122	X	X	X	X	X	X	X	X	X	X	X	X	X	X	X
160	132	5152	X	X	X	X	X	X	X	X	X	X	X	X	X	X	X
200	160	5202	X	X	X	X	X	X	X	X	X	X	X	X	X	X	X
250	200	5252	X	X	X	X	X	X	X	X	X	X	X	X	X	X	X
315	250	5302	X	X	X	X	X	X	X	X	X	X	X	X	X	X	X
400	315	5352	X	X	X	X	X	X	X	X	X	X	X	X	X	X	X
500	400	5402	X	X	X	X	X	X	X	X	X	X	X	X	X	X	X
560	500	5502	X	X	X	X	X	X	X	X	X	X	X	X	X	X	X
630	560	5602	X	X	X	X	X	X	X	X	X	X	X	X	X	X	X

How to select your frequency converter

1. R1 is not available with DX, PF and PD variants.

Voltage (position 9-10)

The drives are available in three voltage ratings. Please be aware that some drives at 500 V supply match a motor power size larger than 400 V - please refer to the individual technical data.

- T2 - 200-240 V three phase supply voltage
- T5 - 380-500 V three phase supply voltage
- T6 - 525-600 V three phase supply voltage
- T7 - 525-690 V three phase supply voltage

Enclosure variants (position 11-13)

Bookstyle units are available for use in control cabinets - the slim design allows many units in one cabinet. Compact units are designed for mounting on walls or

machines. Higher power units are also available as IP00 units for installation in control cabinets.

- C00 - Compact IP00 enclosure
- B20 - Bookstyle IP20 enclosure
- C20 - Compact IP20 enclosure
- CN1 - Compact Nema1 enclosure also fulfilling IP20/21 specifications
- C54 - Compact IP54 enclosure also fulfilling NEMA12 demands

Hardware variants (position 14-15)

The hardware variants differ depending on power size.

- ST - Standard hardware
- SB - Standard hardware and additional brake chopper

- EB - Extended hardware (24 V external supply for backup of control card and load sharing connections) and an additional brake chopper
- EX - Extended hardware (24 V external supply for backup of control card and load sharing connections)
- DE - Extended hardware (24 V external supply for backup of control card and load sharing connections), brake chopper, disconnect and fuses
- DX - Extended hardware (24 V external supply for backup of control card and load sharing connections), disconnect and fuses
- PS - Standard hardware with 24 V external supply for backup of control card
- PB - Standard hardware with 24 V external supply for backup of control card, brake chopper, fuse and disconnect option
- PD - Standard hardware with 24 V external supply for backup of control card, mains fuse and disconnect option
- PF - Standard hardware with 24 V external supply for backup of control card and built in main fuses

RFI filter variants (position 16-17)

Different RFI filter variants offer the possibility to comply with class A1 and class B according to EN55011.

- R0 - No filter performance specified
- R1 - Compliance with class A1 filter
- R3 - Compliance with class B and A1
- R6 - Compliance with marine approvals (VLT 5122-5302, 380-500 V)

Compliance depends on cable length. Please be aware that some power sizes always have built in filters from factory.

Display (position 18-19)

The control unit (display and keypad)

- D0 - No display in the unit (not possible for IP54 enclosures as well as IP21 VLT 5352-5552, 380-480 V and VLT 5402 - 5602, 525-690 V)
- DL - Display supplied with the unit

Field bus option (position 20-22)

A wide selection of high performance field bus options is available

- F0 - No field bus option built in
- F10 - Profibus DP V0/V1 12 Mbaud
- F13 - Profibus DP V0/FMS 12 Mbaud
- F20 - Modbus Plus
- F30 - DeviceNet
- F40 - LonWorks - Free topology
- F41 - LonWorks - 78 kbps
- F42 - LonWorks - 1,25 Mbps
- F50 - Interbus

Application options (position 23-25)

Several application options are available to enhance the functionality of the frequency converter

- A00 - No option built in
- A10 - SyncPos programmable controller (not possible with Modbus Plus and LonWorks)
- A11 - Synchronising controller (not possible with Modbus Plus and LonWorks)
- A12 - Positioning controller (not possible with Modbus Plus and LonWorks)
- A31 - Additional relays - 4 relays for 250 VAC (not possible with field bus options)

Coating (position 26-27)

To increase protection of the drive against aggressive environments it is possible to order coated printed circuit boards.

- C0 - Non coated boards (VLT 5352-5552, 380-500 V and VLT 5042-5602, 525-690 V) only available with coated boards)
 - C1 - Coated boards
-

Ordering form VLT 5000 Series - Typecode

VLT	5			P	T				R	D	F		A		C
-----	---	--	--	---	---	--	--	--	---	---	---	--	---	--	---

<p>Power sizes e.g. 5001</p> <p>Application range P</p> <p>Mains voltage</p> <p>Enclosure</p> <p>Hardware variant</p> <p>RFI filter</p> <p>Display unit (LCP)</p> <p>Fieldbus option card</p> <p>Application option card</p> <p>Coating</p>	<p>5001</p> <p>5002</p> <p>5003</p> <p>5004</p> <p>5005</p> <p>5006</p> <p>5008</p> <p>5011</p> <p>5016</p> <p>5022</p> <p>5027</p> <p>5032</p> <p>5042</p> <p>5052</p> <p>5062</p> <p>5072</p> <p>5102</p> <p>5122</p> <p>5152</p> <p>5202</p> <p>5252</p> <p>5302</p> <p>5352</p> <p>5402</p> <p>5452</p> <p>5502</p> <p>5552</p> <p>5602</p>	<p>T2</p> <p>T5</p> <p>T6</p> <p>T7</p>	<p>B20</p> <p>C00</p> <p>C20</p> <p>C54</p> <p>CN1</p>	<p>ST</p> <p>SB</p> <p>PS</p> <p>PB</p> <p>PD</p> <p>PF</p> <p>EB</p> <p>EX</p> <p>DE</p> <p>DX</p>	<p>R0</p> <p>R1</p> <p>R3</p> <p>R6</p>	<p>D0</p> <p>DL</p>	<p>F00</p> <p>F10</p> <p>F13</p> <p>F20</p> <p>F30</p> <p>F40</p> <p>F41</p> <p>F42</p> <p>F50</p>	<p>A00</p> <p>A10</p> <p>A11</p> <p>A12</p> <p>A31</p>	<p>C0</p> <p>C1</p>
---	---	---	--	---	---	---------------------	--	--	---------------------

No. units of this type	<input type="text"/>	<input type="text"/>	<input type="text"/>
Required delivery date	<input type="text"/>	<input type="text"/>	<input type="text"/>
Ordered by:	<input style="width: 200px; height: 30px;" type="text"/>		

Date: _____

Take a copy of the ordering forms. Fill them in and send or fax your order to the nearest office of the Danfoss sales organisation

How to select your frequency converter

175ZA896.15

■ Selection of modules and accessories

Danfoss offers a wide range of modules and accessories for VLT 5000 Series.

VLT type 5016-5102, 380-500 V
VLT type 5016-5062, 525-600 V

■ LC filter module

The LC filter reduces the voltage rise time (dV/dt) and the ripple current (ΔI) to the motor, thereby making current and voltage almost sinusoidal. The acoustic motor noise is therefore reduced to a minimum.

See also instructions MI.56.DX.51.

■ LCP control unit

Control unit with display and keypad for programming VLT frequency converters. Available as an option for IP 00 and IP 20 units.

Enclosure: IP 65.

■ Remote-mounting kits for LCP

The remote kit option makes it possible to move the display from the frequency converter e.g. to the front panel of an integrated cabinet.

Technical data

Enclosure:	IP 65 front
Max. cable length between VLT and unit:	3 m
Communication std:	RS 422

Reference is also made to instructions MI.56.AX.51 (IP 20) and MI.56.GX.52 (IP 54).

■ IP 4x top cover

IP 4x top cover is an optional enclosure element available for IP 20 Compact units.

If an IP 4x top cover is used, an IP 20 unit is upgraded to comply with enclosure IP 4x from the top. In practice, this means that the unit complies with IP 40 on upper, horizontal surfaces.

A top cover is available for the following Compact units:

- VLT type 5001-5006, 200-240 V
 - VLT type 5001-5011, 380-500 V
 - VLT type 5001-5011, 525-600 V
-

■ Terminal cover

Using a terminal cover, it is possible to field mount an IP 20 unit, type VLT 5008-5052.

A terminal cover is available for the following compact units:

- VLT type 5008-5027, 200-240 V
-

■ Contactors

Danfoss also manufactures a complete range of contactors.

■ Brake resistors

Brake resistors are used in applications where high dynamics are needed or a high inertia load has to be stopped. The brake resistor is used to remove the energy, see also Instructions MI.50.SX.YY and MI.90.FX.YY.

■ Harmonic filter

Harmonic currents do not directly affect the electricity consumption but has an impact on following conditions:

Higher total current to be handled by the installations

- Increases load on transformer (sometimes it will require a larger transformer, particular at retrofit)
- Increases heat losses in transformer and installation
- In some cases demands larger cables, switches and fuses

Higher voltage distortion due to higher current

- Increase risk for disturbing electronic equipment connected to same grid

A high percentage of rectifier load from eg frequency converters, will increase the harmonic current, which must be reduced to avoid the above consequences. Therefore the frequency converter has as standard, built in DC coils reducing the total current with about 40% (compared to devices without any arrangement for harmonic suppression), down to 40-45% THiD.

In some cases there is a need for further suppression (eg retrofit with frequency converters). For this purpose Danfoss can offer two advanced harmonic filters AHF05 and AHF10, bringing the harmonic current down to around 5% and 10% respectively. For further details see instruction MG.80.BX.YY.

■ PC Software tools

PC Software - MCT 10

All drives are equipped with a serial communication port. We provide a PC tool for communication between PC and frequency converter, VLT Motion Control Tool MCT 10 Set-up Software.

MCT 10 Set-up Software

MCT 10 has been designed as an easy to use interactive tool for setting parameters in our frequency converters. The MCT 10 Set-up Software will be useful for:

- Planning a communication network off-line. MCT 10 contains a complete frequency converter database
- Commissioning frequency converters on line
- Saving settings for all frequency converters
- Replacing a drive in a network
- Expanding an existing network
- Future developed drives will be supported

MCT 10 Set-up Software support Profibus DP-V1 via a Master class 2 connection. It makes it possible to on line read/write parameters in a frequency converter via the Profibus network. This will eliminate the need for an extra communication network.

The MCT 10 Set-up Software Modules

The following modules are included in the software package:

**MCT 10 Set-up Software**

Setting parameters
Copy to and from frequency converters
Documentation and print out of parameter settings incl. diagrams

SyncPos

Creating SyncPos programme

Ordering number:

Please order your CD containing MCT 10 Set-up Software using code number 130B1000.

MCT 31

The MCT 31 harmonic calculation PC tool enables easy estimation of the harmonic distortion in a given application. Both the harmonic distortion of Danfoss frequency converters as well as non-Danfoss frequency converters with different additional harmonic reduction

measurements, such as Danfoss AHF filters and 12-18-pulse rectifiers, can be calculated.

Ordering number:

Please order your CD containing the MCT 31 PC tool using code number 130B1031.

■ Line reactors for load sharing applications

Line reactors are used when connecting frequency converters together in a load sharing application.

200 - 240 V units

VLT type	Nominal power at CT [kW]	Input current [A]	Voltage drop [%]	Inductivity [mH]	Ordering number
5001	0.75	3.4	1.7	1.934	175U0021
5002	1.10	4.8	1.7	1.387	175U0024
5003	1.50	7.1	1.7	1.050	175U0025
5004	2.20	9.5	1.7	0.808	175U0026
5005	3.0	11.5	1.7	0.603	175U0028
5006	4.0	14.5	1.7	0.490	175U0029
5008	5.5	32.0	1.7	0.230	175U0030
5011	7.5	46.0	1.7	0.167	175U0032
5016	11.0	61.0	1.7	0.123	175U0034
5022	15.0	73.0	1.7	0.102	175U0036
5027	18.5	88.0	1.7	0.083	175U0047

380 - 500 V units

VLT type	Nominal power at CT [kW]	Input current [A]	Voltage drop [%]	Inductivity [mH]	Ordering number
5001	0.75	2.3	1	3.196	175U0015
5002	1.1	2.6	1	2.827	175U0017
5003	1.5	3.8	1	1.934	175U0021
5004	2.2	5.3	1	1.387	175U0024
5005	3	7.0	1	1.050	175U0025
5006	4	9.1	1	0.808	175U0026
5008	5.5	12.2	1	0.603	175U0028
5011	7.5	15.0	1	0.490	175U0029
5016	11	32.0	1	0.230	175U0030
5022	15	37.5	1	0.196	175U0031
5027	18.5	44.0	1	0.167	175U0032
5032	22	60.0	1	0.123	175U0034
5042	30	72.0	1	0.102	175U0036
5052	37	89.0	1	0.083	175U0047
5062	45	104.0	1	0.070	175U1009
5072	55	144.6	1	0.051	175U0070
5102	75	174.1	1	0.042	175U0071

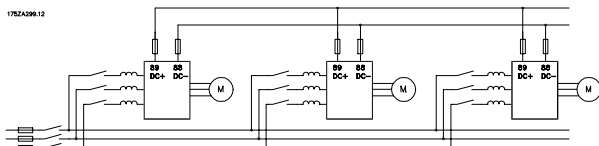

See also instruction MI.50.NX.YY for further information.

■ Accessories for VLT 5000 Series

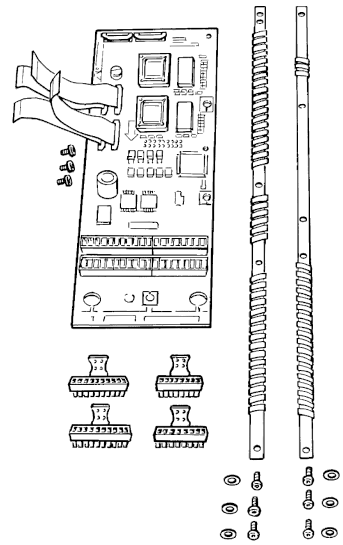
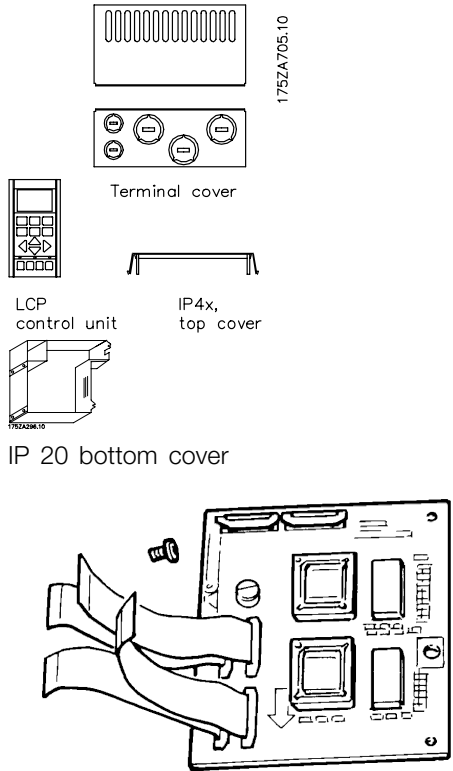

■ Ordering numbers, misc. hardware:

Type	Description	Ordering no.
IP 4x top cover/NEMA 1 kit ¹⁾	Option, VLT 5001-5006, 200-240 V	175Z0928
IP 4x top cover/NEMA 1 kit ¹⁾	Option, VLT 5001-5011, 380-500 V and 525-600 V	175Z0928
NEMA 12 bonding plate ²⁾	Option, VLT 5001-5006, 200-240 V	175H4195
NEMA 12 bonding plate ²⁾	Option, VLT 5001-5011, 380-500 V	175H4195
IP 20 terminal cover	Option, VLT 5008-5016, 200-240 V	175Z4622
IP 20 terminal cover	Option, VLT 5022-5027, 200-240 V	175Z4623
IP 20 terminal cover	Option, VLT 5016-5032, 380-500 V and 525-600 V	175Z4622
IP 20 terminal cover	Option, VLT 5042-5062, 380-500 V and 525-600 V	175Z4623
IP 20 terminal cover	Option, VLT 5072-5102, 380-500 V	175Z4280
IP 20 bottom cover	VLT 5032-5052, 200 - 240 V	176F1800
Terminal Adapter Kit	VLT 5032-5052, 200 - 240 V IP 00/Nema 1(IP 20), ST	176F1805
Terminal Adapter Kit	VLT 5032-5052, 200 - 240 V IP 00/Nema 1(IP 20), SB	176F1806
Terminal Adapter Kit	VLT 5032-5052, 200 - 240 V IP 00/Nema 1(IP 20), EB	176F1807
Terminal Adapter Kit	VLT 5032-5052, 200 - 240 V IP 54, ST	176F1808
Terminal Adapter Kit	VLT 5032-5052, 200 - 240 V IP 54, SB	176F1809
Encoder converter / 5 V TTL Linedriver / 24 V DC		175Z1929

Rittal Installation Kits

Type	Description	Order No.
Rittal TS8 enclosure for IP00 ³⁾	Installation kit for 1800mm high enclosure, VLT5122-5152; 380-500V, VLT 5042-5152, 525-690V	176F1824
Rittal TS8 enclosure for IP00 ³⁾	Installation kit for 2000mm high enclosure, VLT5122-5152, 380-500V; VLT 5042-5152, 525-690V	176F1826
Rittal TS8 enclosure for IP00 ³⁾	Installation kit for 1800mm high enclosure, VLT5202-5302, 380-500V; VLT 5202-5352, 525-690V	176F1823
Rittal TS8 enclosure for IP00 ³⁾	Installation kit for 2000mm high enclosure, VLT5202-5302, 380-500V; VLT 5202-5352, 525-690V	176F1825
Rittal TS8 enclosure for IP00 ³⁾	Installation kit for 2000mm high enclosure, VLT5352-5552, 380-500V; VLT 5402-5602, 525-690V	176F1850
Floor stand for IP21 and IP54 enclosure ³⁾	Option, VLT5122-5302, 380-500V; VLT 5042-5352, 525-690V	176F1827
Mains shield kit	Protection kit:: VLT 5122-5302, 380-500 V VLT 5042-5352, 525-690 V	176F0799
	Protection kit:: VLT 5352-5552, 380-500 V; VLT 5402-5602, 525-690 V	176F1851

¹⁾ IP 4xNEMA top cover is for Compact IP 20 units only and is only intended for horizontal surfaces that comply with IP 4x. The kit also contains a bonding plate (UL).

²⁾ NEMA 12 bonding plate (UL) is for compact IP 54 units only.

³⁾ For details: See High Power Installation Guide, MI.90.JX.YY.

■ Ordering numbers, control card options, etc.:

LCP:

Type	Description	Ordering no.	
IP 65 LCP option	Separate LCP, only for IP 20 units	175Z0401	
LCP remote-mounting kit/IP00/IP20/NEMA 1	Remote-mounting kit for LCP, for IP 00/20 units	175Z0850	incl. 3 m cable
LCP remote-mounting kit IP 54	Remote-mounting kit for LCP, for IP 54 units	175Z7802	incl. 3 m cable
Cable for LCP	Separate cable	175Z0929	3 m cable

LCP: Control unit with display and keypad.
Supplied excl. LCP.

²⁾ NEMA 12 bonding plate (UL) is for compact IP 54 units only.

1. IP 4xNEMA 1 top cover is for Compact IP 20 units only and is only intended for horizontal surfaces that comply with IP 4x. The kit also contains a bonding plate (UL).

Fieldbus options and accessories:

Profibus:

Type	Description	Uncoated Ordering no.	Coated Ordering no.
Profibus option DP V0/V1	Incl. memory option	175Z0404	175Z2625
Profibus option DP V0/V1	excl. memory option	175Z0402	
Profibus option DP V0/FMS	incl. memory option	175Z3722	175Z3723

Type	Description	Ordering no.
Profibus Sub D9 Connector for IP 20 / IP 00	VLT 5001-5027, 200-240 V	175Z3568
	VLT 5001-5102, 380-500 V	
	VLT 5001-5062, 525-600 V	
	VLT 5032-5052, 200-240 V	176F1822

LonWorks:

LonWorks option, Free topology	Incl. memory option	176F1500	176F1503
LonWorks option, Free topology	excl. memory option	176F1512	
LonWorks option, 78 KBPS	Incl. memory option	176F1501	176F1504
LonWorks option, 78 KBPS	excl. memory option	176F1513	
LonWorks option, 1.25 MBPS	Incl. memory option	176F1502	176F1505
LonWorks option, 1.25 MBPS	excl. memory option	176F1514	

DeviceNet:

DeviceNet option	Incl. memory option	176F1580	176F1581
DeviceNet option	excl. memory option	176F1584	

Modbus:

Modbus Plus for Compact units	Incl. memory option	176F1551	176F1553
Modbus Plus for Compact units	Excl. memory option	176F1559	
Modbus Plus for Bookstyle units	Incl. memory option	176F1550	176F1552
Modbus Plus for Bookstyle units	Excl. memory option	176F1558	
Modbus RTU	Not factory mounted	175Z3362	

Interbus:

Interbus	Incl. memory option	175Z3122	175Z3191
Interbus	Excl. memory option	175Z2900	

Application options:

Programmable SyncPos controller	Application option	175Z0833	175Z3029
Synchronising controller	Application option	175Z3053	175Z3056
Positioning controller	Application option	175Z3055	175Z3057
Relay card option	Application option	175Z2500	175Z2901
Winder Option	Not factory mounted, SW version	175Z3245	
	3.40		
Ring Spinning Option	Not factory mounted, SW version	175Z3463	
	3.41		
Wobble Option	Not factory mounted, SW version	175Z3467	
	3.41		

Options can be ordered as factory built-in options, see ordering information.

For information on fieldbus and application option compatibility with older software versions, please contact your Danfoss supplier.

If the Fieldbus options are to be used without application option a version with memory option must be ordered.

■ LC filters for VLT 5000

When a motor is controlled by a frequency converter, resonance noise will be heard from the motor. This noise, which is the result of the design of the motor, arises every time one of the inverter switches in the frequency converter is activated. The frequency of the resonance noise thus corresponds to the switching frequency of the frequency converter.

For the VLT 5000 Series, Danfoss is able to supply an LC filter to dampen the acoustic motor noise.

The filter reduces the ramp-up time of the voltage, the peak load voltage U_{PEAK} and the ripple current ΔI to the motor, which means that current and voltage become almost sinusoidal. Consequently, the acoustic motor noise is reduced to a minimum.

Because of the ripple current in the coils, there will be some noise from the coils. This problem can be solved by integrating the filter in a cabinet or similar.

■ Ordering numbers, LC filter modules Mains supply 3 x 200-240 V

High overload torque						
LC filter for VLT type	LC filter enclosure	Rated current at 200 V	Max. torque at CT/VT	Max. output frequency	Power dissipation	Ordering no.
5001-5003	Bookstyle IP 20	7.8 A	160%	120 Hz		175Z0825
5004-5006	Bookstyle IP 20	15.2 A	160%	120 Hz		175Z0826
5001-5006	Compact IP 20	15.2 A	160%	120 Hz		175Z0832
5008	Compact IP 00	25 A	160%	60 Hz	85 W	175Z4600
5011	Compact IP 00	32 A	160%	60 Hz	90 W	175Z4601
5016	Compact IP 00	46 A	160%	60 Hz	110 W	175Z4602
5022	Compact IP 00	61 A	160%	60 Hz	170 W	175Z4603
5027	Compact IP 00	73 A	160%	60 Hz	250 W	175Z4604
5032	Compact IP 20	88 A	150 %	60 Hz		175Z4700
5045	Compact IP 20	115 A	150 %	60 Hz		175Z4702
5052	Compact IP 20	143 A	150 %	60 Hz		175Z4702
Normal overload torque						
5008	Compact IP 00	32 A	110%	60 Hz	90 W	175Z4601
5011	Compact IP 00	46 A	110%	60 Hz	110 W	175Z4602
5016	Compact IP 00	61 A	110%	60 Hz	170 W	175Z4603
5022	Compact IP 00	73 A	110%	60 Hz	250 W	175Z4604
5027	Compact IP 00	88 A	110%	60 Hz	320 W	175Z4605
5032	Compact IP 20	115 A	110 %	60 Hz		175Z4702
5042	Compact IP 20	143 A	110 %	60 Hz		175Z4702
5052	Compact IP 20	170 A	110 %	60 Hz		175Z4703



NB!:

When using LC-filters, the switching frequency must be 4.5 kHz (see parameter 411).

Mains supply 3 x 380 - 500 V

High overload torque

LC filter for VLT type	LC filter enclosure	Rated current at 400/500 V	Max. torque at CT/VT	Max. output frequency	Power dissipation	Ordering no.
5001-5005	Bookstyle IP 20	7.2 A / 6.3 A	160%	120 Hz		175Z0825
5006-5011	Bookstyle IP 20	16 A / 14.5 A	160%	120 Hz		175Z0826
5001-5011	Compact IP 20	16 A / 14.5 A	160%	120 Hz		175Z0832
5016	Compact IP 00	24 A / 21.7 A	160%	60 Hz	170 W	175Z4606
5022	Compact IP 00	32 A / 27.9 A	160%	60 Hz	180 W	175Z4607
5027	Compact IP 00	37.5 A / 32 A	160%	60 Hz	190 W	175Z4608
5032	Compact IP 00	44 A / 41.4 A	160%	60 Hz	210 W	175Z4609
5042	Compact IP 00	61 A / 54 A	160%	60 Hz	290 W	175Z4610
5052	Compact IP 00	73 A / 65 A	160%	60 Hz	410 W	175Z4611
5062	Compact IP 20	90 A / 80 A	160 %	60 Hz	400 W	175Z4700
5072	Compact IP 20	106 A / 106 A	160 %	60 Hz	500 W	175Z4701
5102	Compact IP 20	147 A / 130 A	160 %	60 Hz	600 W	175Z4702
5122	Compact IP 20	177 A / 160 A	160 %	60 Hz	750 W	175Z4703
5152	Compact IP 20	212 A / 190 A	160 %	60 Hz	750 W	175Z4704
5202	Compact IP 20	260 A / 240 A	160 %	60 Hz	900 W	175Z4705
5252	Compact IP 20	315 A / 302 A	160 %	60 Hz	1000 W	175Z4706
5302	Compact IP 20	395 A / 361 A	160 %	60 Hz	1100 W	175Z4707
5352	Compact IP 20	480 A / 443 A	160 %	60 Hz	1700 W	175Z3139
5452	Compact IP 20	600 A / 540 A	160 %	60 Hz	2100 W	175Z3140
5502	Compact IP 20	658 A / 590 A	160 %	60 Hz	2100 W	175Z3141
5552	Compact IP 20	745 A / 678 A	160 %	60 Hz	2500 W	175Z3142

Normal overload torque

5016	Compact IP 00	32 A / 27.9 A	110%	60 Hz	180 W	175Z4607
5022	Compact IP 00	37.5 A / 32 A	110%	60 Hz	190 W	175Z4608
5027	Compact IP 00	44 A / 41.4 A	110%	60 Hz	210 W	175Z4609
5032	Compact IP 00	61 A / 54 A	110%	60 Hz	290 W	175Z4610
5042	Compact IP 00	73 A / 65 A	110%	60 Hz	410 W	175Z4611
5052	Compact IP 00	90 A / 78 A	110%	60 Hz	480 W	175Z4612
5062	Compact IP 20	106 A / 106 A	110 %	60 Hz	500 W	175Z4701
5072	Compact IP 20	147 A / 130 A	110 %	60 Hz	600 W	175Z4702
5102	Compact IP 20	177 A / 160 A	110 %	60 Hz	750 W	175Z4703
5122	Compact IP 20	212 A / 190 A	110 %	60 Hz	750 W	175Z4704
5152	Compact IP 20	260 A / 240 A	110 %	60 Hz	900 W	175Z4705
5202	Compact IP 20	315 A / 302 A	110 %	60 Hz	1000 W	175Z4706
5252	Compact IP 20	368 A / 361 A	110 %	60 Hz	1100 W	175Z4707
5302	Compact IP 20	480 A / 443 A	110 %	60 Hz	1700 W	175Z3139
5352	Compact IP 20	600 A / 540 A	110 %	60 Hz	2100 W	175Z3140
5452	Compact IP 20	658 A / 590 A	110 %	60 Hz	2100 W	175Z3141
5502	Compact IP 20	745 A / 678 A	110 %	60 Hz	2500 W	175Z3142
5552	Compact IP 20	800 A / 730 A	110%	60 Hz	Please contact Danfoss	

LC filters for VLT 5001-5062, 525 - 600 V, please contact Danfoss.



NB!:

When using LC-filters, the switching frequency must be 4.5 kHz (see parameter 411).

VLT 5352-5502 LC filters can be operated at 3 kHz switching frequency. Use 60 ° AVM switch pattern.

VLT 5000 Design Guide

Mains supply 3 x 690 V						
160% overload torque	110% overload torque	Rated Current at 690 V (A)	Max. output frequency (Hz)	Power dissipation (W)	Ordering no. IP00	Ordering no. IP20
5042		46	60	240	130B2223	130B2258
5052	5042	54	60	290	130B2223	130B2258
5062	5052	73	60	390	130B2225	130B2260
5072	5062	86	60	480	130B2225	130B2260
5102	5072	108	60	600	130B2226	130B2261
5122	5102	131	60	550	130B2228	130B2263
5152	5122	155	60	680	130B2228	130B2263
5202	5152	192	60	920	130B2229	130B2264
5252	5202	242	60	750	130B2231	130B2266
5302	5252	290	60	1000	130B2231	130B2266
5352	5302	344	60	1050	130B2232	130B2267
5402	5352	400	60	1150	130B2234	130B2269
5502	5402	430	60	420	130B2235	130B2238
5602	5502	530	60	500	130B2236	130B2239
	5602	600	60	570	130B2237	130B2240

dU/dt filters for VLT 5000

The dU/dt filters reduce dU/dt to approx. 500 V / μ sec.
These filters do not reduce noise or Upeak.



NB!:

When using dU/dt filters, the switching frequency must be 1.5 kHz (see parameter 411).

Mains supply 3 x 690 V						
160% overload torque	110% overload torque	Rated Current at 690 V (A)	Max. output frequency (Hz)	Power dissipation (W)	Ordering no. IP 00	Ordering no. IP20
5042		46	60	85	130B2153	130B2187
5052	5042	54	60	90	130B2154	130B2188
5062	5052	73	60	100	130B2155	130B2189
5072	5062	86	60	110	130B2156	130B2190
5102	5072	108	60	120	130B2157	130B2191
5122	5102	131	60	150	130B2158	130B2192
5152	5102	155	60	180	130B2159	130B2193
5202	5152	192	60	190	130B2160	130B2194
5252	5202	242	60	210	130B2161	130B2195
5302	5252	290	60	350	130B2162	130B2196
5352	5302	344	60	480	130B2163	130B2197
5402	5352	400	60	540	130B2165	130B2199
5502	5402	430	60	1600	130B2241	130B2244
5602	5502	530	60	2000	130B2242	130B2245
	5602	600	60	2300	130B2243	130B2246

■ Brake resistors, VLT 5001 - 5052 / 200 - 240 V

Standard brake resistors

VLT	10% duty cycle			40% duty cycle		
	Resistance [ohm]	Power [kW]	Code No.	Resistance [ohm]	Power [kW]	Code No.
5001	145	0.065	175U1820	145	0.260	175U1920
5002	90	0.095	175U1821	90	0.430	175U1921
5003	65	0.250	175U1822	65	0.80	175U1922
5004	50	0.285	175U1823	50	1.00	175U1923
5005	35	0.430	175U1824	35	1.35	175U1924
5006	25	0.8	175U1825	25	3.00	175U1925
5008	20	1.0	175U1826	20	3.50	175U1926
5011	15	1.8	175U1827	15	5.00	175U1927
5016	10	2.8	175U1828	10	9.0	175U1928
5022	7	4.0	175U1829	7	10.0	175U1929
5027	6	4.8	175U1830	6	12.7	175U1930
5032	4.7	6	175U1954	Not available	Not available	Not available
5042	3.3	8	175U1955	Not available	Not available	Not available
5052	2.7	10	175U1956	Not available	Not available	Not available

See instruction MI.90.FX.YY for further information.

Flatpack brake resistors for horizontal conveyors

VLT type	Motor [kW]	Resistor [ohm]	Size	Order number	Max. duty cycle [%]
5001	0.75	150	150 Ω 100 W	175U1005	14.0
5001	0.75	150	150 Ω 200 W	175U0989	40.0
5002	1.1	100	100 Ω 100 W	175U1006	8.0
5002	1.1	100	100 Ω 200 W	175U0991	20.0
5003	1.5	72	72 Ω 200 W	175U0992	16.0
5004	2.2	47	50 Ω 200 W	175U0993	9.0
5005	3	35	35 Ω 200 W	175U0994	5.5
5005	3	35	72 Ω 200 W	2 x 175U0992 ¹	12.0
5006	4	25	50 Ω 200 W	2 x 175U0993 ¹	11.0
5008	5.5	20	40 Ω 200 W	2 x 175U0996 ¹	6.5
5011	7.5	13	27 Ω 200 W	2 x 175U0995 ¹	4.0

1. Order 2 pcs.

Mounting angle for flatpack resistor 100 W 175U0011

Mounting angle for flatpack resistor 200 W 175U0009

Mounting frame for 1 resistor narrow (slim bookstyle) 175U0002

Mounting frame for 2 resistors narrow (slim bookstyle) 175U0004

Mounting frame for 2 resistors broad (wide bookstyle) 175U0003

See *Instruction MI.50.BX.YY* for further information.

**■ Ordering numbers, Brake resistors, VLT
5001 - 5552 / 380 - 500 V**
Standard brake resistors

VLT	10% duty cycle			40% duty cycle		
	Resistance [ohm]	Power [kW]	Code No.	Resistance [ohm]	Power [kW]	Code No.
5001	620	0.065	175U1840	620	0.260	175U1940
5002	425	0.095	175U1841	425	0.430	175U1941
5003	310	0.250	175U1842	310	0.80	175U1942
5004	210	0.285	175U1843	210	1.35	175U1943
5005	150	0.430	175U1844	150	2.0	175U1944
5006	110	0.60	175U1845	110	2.4	175U1945
5008	80	0.85	175U1846	80	3.0	175U1946
5011	65	1.0	175U1847	65	4.5	175U1947
5016	40	1.8	175U1848	40	5.0	175U1948
5022	30	2.8	175U1849	30	9.3	175U1949
5027	25	3.5	175U1850	25	12.7	175U1950
5032	20	4.0	175U1851	20	13.0	175U1951
5042	15	4.8	175U1852	15	15.6	175U1952
5052	12	5.5	175U1853	12	19.0	175U1953
5062	9.8	15	175U2008	9.8	38.0	175U2008
5072	7.3	13	175U0069	5.7	38.0	175U0068
5102	5.7	15	175U0067	4.7	45.0	175U0066
5122 ²⁾	3.8	22	175U1960			
5152 ²⁾	3.2	27	175U1961			
5202 ²⁾	2.6	32	175U1962			
5252 ²⁾	2.1	39	175U1963			
5302 ²⁾	1.65	56	2 x 175U1061 ¹⁾			
5352-5552 ²⁾	2.6	72	2 x 175U1062 ^{1) 3)}			

1. Order 2 pcs.
2. Resistors selected for 300 second cycle.
3. Rating fulfilled up to VLT 5452, the torque is reduced for VLT 5502 and VLT 5552.

See *Instruction MI.90.FX.YY* for further information.

Flatpack brake resistors for horizontal conveyors

VLT type	Motor [kW]	Resistor [ohm]	Size	Order number	Max. duty cycle [%]
5001	0.75	630	620 Ω 100 W	175U1001	14.0
5001	0.75	630	620 Ω 200 W	175U0982	40.0
5002	1.1	430	430 Ω 100 W	175U1002	8.0
5002	1.1	430	430 Ω 200 W	175U0983	20.0
5003	1.5	320	310 Ω 200 W	175U0984	16.0
5004	2.2	215	210 Ω 200 W	175U0987	9.0
5005	3	150	150 Ω 200 W	175U0989	5.5
5005	3	150	300 Ω 200 W	2 x 175U0985 ¹⁾	12.0
5006	4	120	240 Ω 200 W	2 x 175U0986 ¹⁾	11.0
5008	5.5	82	160 Ω 200 W	2 x 175U0988 ¹⁾	6.5
5011	7.5	65	130 Ω 200 W	2 x 175U0990 ¹⁾	4.0

1. Order 2 pcs.

Mounting angle for flatpack resistor 100 W 175U0011.
 Mounting angle for flatpack resistor 200 W 175U0009.
 Mounting frame for 1 resistor narrow (slim bookstyle) 175U0002.
 Mounting frame for 2 resistors narrow (slim bookstyle) 175U0004.
 Mounting frame for 2 resistors broad (wide bookstyle) 175U0003.
 See *Instruction MI.50.BX.YY* for further information.
 For 525-600 V and 525-690 V please contact Danfoss.

■ Ordering numbers, Harmonic filters

Harmonic filters are used to reduce mains harmonics

- AHF 010: 10% current distortion
- AHF 005: 5% current distortion

380-415 V, 50Hz

I _{AHF,N}	Typical Motor Used [kW]	Danfoss ordering number		VLT 5000
		AHF 005	AHF 010	
10 A	4, 5.5	175G6600	175G6622	5006, 5008
19 A	7.5	175G6601	175G6623	5011
26 A	11	175G6602	175G6624	5016
35 A	15, 18.5	175G6603	175G6625	5022, 5027
43 A	22	175G6604	175G6626	5032
72 A	30, 37	175G6605	175G6627	5042, 5052
101 A	45, 55	175G6606	175G6628	5062, 5072
144 A	75	175G6607	175G6629	5102
180 A	90	175G6608	175G6630	5122
217 A	110	175G6609	175G6631	5152
289 A	132, 160	175G6610	175G6632	5202, 5252
324 A		175G6611	175G6633	
370 A	200	175G6688	175G6691	5302
Higher ratings can be achieved by paralleling the filter units				
434 A	250	Two 217 A units		5352
578 A	315	Two 289 A units		5452
613 A	355	289 A and 324 A units		5502
648 A	400	Two 324 A units		5552

Please note that the matching of the typical Danfoss frequency converter and filter is pre-calculated based on 400 V and assuming typical motor load (4 or 2 pole motor): VLT 5000 series is based on a max. 160 % torque application. The pre-calculated filter current may be different than the input current ratings of VLT 5000 as stated in the respective operating instructions, as these numbers are based on different operating conditions.

440-480 V, 60Hz

I _{AHF,N}	Typical Motor Used [HP]	Danfoss ordering number		VLT 5000
		AHF 005	AHF 010	
19 A	10, 15	175G6612	175G6634	5011, 5016
26 A	20	175G6613	175G6635	5022
35 A	25, 30	175G6614	175G6636	5027, 5032
43 A	40	175G6615	175G6637	5042
72 A	50, 60	175G6616	175G6638	5052, 5062
101 A	75	175G6617	175G6639	5072
144 A	100, 125	175G6618	175G6640	5102, 5122
180 A	150	175G6619	175G6641	5152
217 A	200	175G6620	175G6642	5202
289 A	250	175G6621	175G6643	5252
324 A	300	175G6689	175G6692	5302
370 A	350	175G6690	175G6693	5352
Higher ratings can be achieved by paralleling the filter units				
506 A	450	217 A and 289 A units		5452
578 A	500	Two 289 A units		5502
648 A	600	Two 324 A units		5552

Please note that the matching of the typical Danfoss frequency converter and filter is pre-calculated based on 480 V and assuming typical motor load (4 or 2 pole motor): VLT 5000 series is based on a max. 160 % torque application. The pre-calculated filter current may be different than the input current ratings of VLT 5000 as stated in the respective operating instructions, as these numbers are based on different operating conditions.

500 V, 50 Hz

I _{AHF,N}	Typical Motor Used [kW]	Danfoss ordering number		VLT 5000
		AHF 005	AHF 010	
10 A	4, 5.5	175G6644	175G6656	5006, 5008
19 A	7.5, 11	175G6645	175G6657	5011, 5016
26 A	15, 18.5	175G6646	175G6658	5022, 5027
35 A	22	175G6647	175G6659	5032
43 A	30	175G6648	175G6660	5042
72 A	37, 45	175G6649	175G6661	5052, 5062
101 A	55, 75	175G6650	175G6662	5062, 5072
144 A	90, 110	175G6651	175G6663	5102, 5122
180 A	132	175G6652	175G6664	5152
217 A	160	175G6653	175G6665	5202
289 A	200	175G6654	175G6666	5252
324 A	250	175G6655	175G6667	5302
Higher ratings can be achieved by paralleling the filter units				
434 A	315	Two 217 A units		5352
469 A	355	180 A and 289 A units		5452
578 A	400	Two 289 A units		5502
648 A	500	Two 324 A units		5552

Please note that the matching of the typical Danfoss frequency converter and filter is pre-calculated based on 500 V and assuming typical motor load. VLT 5000 series is based on a 160 % torque application. The pre-calculated filter current may be varying from the input current ratings of VLT 5000 as stated in the respective operating instructions, as these numbers are based on different operating conditions. For further combinations, please consult MG.80.BX.YY.

690 V, 50 Hz

I AHF,N	Typical motor used (kW)	Ordering no. AHF 005	Ordering no. AHF 010	VLT 5000 160%	VLT 5000 110%
43	37, 45	130B2328	130B2293	5042, 5042	5042
72	55, 75	130B2330	130B2295	5062, 5072	5052, 5062
101	90	130B2331	130B2296	5102	5072
144	110, 132	130B2333	130B2298	5122, 5152	5102, 5122
180	160	130B2334	130B2299	5202	5152
217	200	130B2335	130B2300	5252	5202
289	250	130B2331 & 130B2333	130B2301	5302	5252
324	315	130B2333 & 130B2334	130B2302	5352	5302
370	400	130B2334 & 130B2335	130B2304		5352
469	500	130B2333 & 2 x 130B2334	130B2299 & 130B2301	5502	5402
578	560	3 x 130B2334	2 x 130B2301	5602	5502
613	630	3 x 130B2335	130B2301 & 130B2302		5602

■ General technical data

Mains supply (L1, L2, L3):

Supply voltage 200-240 V units	3 x 200/208/220/230/240 V ±10%
Supply voltage 380-500 V units	3 x 380/400/415/440/460/500 V ±10%
Supply voltage 525-600 V units	3 x 525/550/575/600 V ±10%
Supply voltage 525-690 V units	3 x 525/550/575/600/690 V ±10%
Supply frequency	48-62 Hz +/- 1%

See the section on special conditions in the Design Guide

Max imbalance of supply voltage:

VLT 5001-5011, 380-500 V and 525-600 V and VLT 5001-5006, 200-240 V	±2.0% of rated supply voltage
VLT 5016-5062, 380-500 V and 525-600 V and VLT 5008-5027, 200-240 V	±1.5% of rated supply voltage
VLT 5072-5552, 380-500 V and VLT 5032-5052, 200-240 V	±3.0% of rated supply voltage
VLT 5042-5602, 525-690 V	±3.0% of rated supply voltage
True Power factor (λ)	0.90 nominal at rated load
Displacement Power Factor ($\cos \varphi$)	near unity (>0.98)
No. of switchings on supply input L1, L2, L3	approx. 1 time/min.

See the section on special conditions in the Design Guide

VLT output data (U, V, W):

Output voltage	0-100% of supply voltage
Output frequency VLT 5001-5027, 200-240 V	0-132 Hz, 0-1000 Hz
Output frequency VLT 5032-5052, 200-240 V	0-132 Hz, 0-450 Hz
Output frequency VLT 5001-5052, 380-500 V	0-132 Hz, 0-1000 Hz
Output frequency VLT 5062-5302, 380-500 V	0-132 Hz, 0-450 Hz
Output frequency VLT 5352-5552, 380-500 V	0-132 Hz, 0-300 Hz
Output frequency VLT 5001-5011, 525-600 V	0-132 Hz, 0-700 Hz
Output frequency VLT 5016-5052, 525-600 V	0-132 Hz, 0-1000 Hz
Output frequency VLT 5062, 525-600 V	0-132 Hz, 0-450 Hz
Output frequency VLT 5042-5302, 525-690 V	0-132 Hz, 0-200 Hz
Output frequency VLT 5352-5602, 525-690 V	0-132 Hz, 0-150 Hz
Rated motor voltage, 200-240 V units	200/208/220/230/240 V
Rated motor voltage, 380-500 V units	380/400/415/440/460/480/500 V
Rated motor voltage, 525-600 V units	525/550/575 V
Rated motor voltage, 525-690 V units	525/550/575/690 V
Rated motor frequency	50/60 Hz
Switching on output	Unlimited
Ramp times	0.05-3600 sec.

Torque characteristics:

Starting torque, VLT 5001-5027, 200-240 V and VLT 5001-5552, 380-500 V	160% for 1 min.
Starting torque, VLT 5032-5052, 200-240 V	150% for 1 min.
Starting torque, VLT 5001-5062, 525-600 V	160% for 1 min.
Starting torque, VLT 5042-5602, 525-690 V	160% for 1 min.
Starting torque	180% for 0.5 sec.
Acceleration torque	100%
Overload torque, VLT 5001-5027, 200-240 V and VLT 5001-5552, 380-500 V, VLT 5001-5062, 525-600 V, and VLT 5042-5602, 525-690 V	160%
Overload torque, VLT 5032-5052, 200-240 V	150%
Arresting torque at 0 rpm (closed loop)	100%

The torque characteristics given are for the frequency converter at the high overload torque level (160%). At the normal overload torque (110%), the values are lower.

VLT 5000 Design Guide

	Braking at high overload torque level		
	Cycle time (s)	Braking duty cycle at 100% torque	Braking duty cycle at over torque (150/160%)
200-240 V			
5001-5027	120	Continuous	40%
5032-5052	300	10%	10%
380-500 V			
5001-5102	120	Continuous	40%
5122-5252	600	Continuous	10%
5302	600	40%	10%
5352-5552	600	40% ¹⁾	10% ²⁾
525-600 V			
5001-5062	120	Continuous	40%
525-690 V			
5042-5352	600	40%	10%
5402-5602	600	40% ³⁾	10% ⁴⁾

1) VLT 5502 at 90% torque. At 100% torque the braking duty cycle is 13%. At mains rating 441-500 V 100% torque the braking duty cycle is 17%.

VLT 5552 at 80% torque. At 100% torque the braking duty cycle is 8%.

2) Based on 300 second cycle:

For VLT 5502 the torque is 145%.

For VLT 5552 the torque is 130%.

3) VLT 5502 at 80% torque.

VLT 5602 at 71% torque.

4) Based on 300 second cycle.

For VLT 5502 the torque is 128%.

For VLT 5602 the torque is 114%.

Control card, digital inputs:

Number of programmable digital inputs	8
Terminal nos.	16, 17, 18, 19, 27, 29, 32, 33
Voltage level	0-24 V DC (PNP positive logics)
Voltage level, logical '0'	< 5 V DC
Voltage level, logical '1'	>10 V DC
Maximum voltage on input	28 V DC
Input resistance, R _i	2 kΩ
Scanning time per input	3 msec.

Reliable galvanic isolation: All digital inputs are galvanically isolated from the supply voltage (PELV). In addition, the digital inputs can be isolated from the other terminals on the control card by connecting an external 24 V DC supply and opening switch 4. VLT 5001-5062, 525-600 V do not meet PELV.

Control card, analogue inputs:

No. of programmable analogue voltage inputs/thermistor inputs	2
Terminal nos.	53, 54
Voltage level	0 - ± 10 V DC (scalable)
Input resistance, R_i	10 k Ω
No. of programmable analogue current inputs	1
Terminal no.	60
Current range	0/4 - ± 20 mA (scalable)
Input resistance, R_i	200 Ω
Resolution	10 bit + sign
Accuracy on input	Max. error 1% of full scale
Scanning time per input	3 msec.
Terminal no. ground	55

Reliable galvanic isolation: All analogue inputs are galvanically isolated from the supply voltage (PELV) as well as other inputs and outputs.*

* VLT 5001-5062, 525-600 V do not meet PELV.

Control card, pulse/encoder input:

No. of programmable pulse/encoder inputs	4
Terminal nos.	17, 29, 32, 33
Max. frequency on terminal 17	5 kHz
Max. frequency on terminals 29, 32, 33	20 kHz (PNP open collector)
Max. frequency on terminals 29, 32, 33	65 kHz (Push-pull)
Voltage level	0-24 V DC (PNP positive logics)
Voltage level, logical '0'	< 5 V DC
Voltage level, logical '1'	>10 V DC
Maximum voltage on input	28 V DC
Input resistance, R_i	2 k Ω
Scanning time per input	3 msec.
Resolution	10 bit + sign
Accuracy (100-1 kHz), terminals 17, 29, 33	Max. error: 0.5% of full scale
Accuracy (1-5 kHz), terminal 17	Max. error: 0.1% of full scale
Accuracy (1-65 kHz), terminals 29, 33	Max. error: 0.1% of full scale

Reliable galvanic isolation: All pulse/encoder inputs are galvanically isolated from the supply voltage (PELV). In addition, pulse and encoder inputs can be isolated from the other terminals on the control card by connecting an external 24 V DC supply and opening switch 4.*

* VLT 5001-5062, 525-600 V do not meet PELV.

Control card, digital/pulse and analogue outputs:

No. of programmable digital and analogue outputs	2
Terminal nos.	42, 45
Voltage level at digital/pulse output	0 - 24 V DC
Minimum load to ground (terminal 39) at digital/pulse output	600 Ω
Frequency ranges (digital output used as pulse output)	0-32 kHz
Current range at analogue output	0/4 - 20 mA
Maximum load to ground (terminal 39) at analogue output	500 Ω
Accuracy of analogue output	Max. error: 1.5% of full scale
Resolution on analogue output.	8 bit

Reliable galvanic isolation: All digital and analogue outputs are galvanically isolated from the supply voltage (PELV), as well as other inputs and outputs.*

* VLT 5001-5062, 525-600 V do not meet PELV.

Control card, 24 V DC supply:

Terminal nos.	12, 13
Max. load (short-circuit protection)	200 mA
Terminal nos. ground	20, 39

Reliable galvanic isolation: The 24 V DC supply is galvanically isolated from the supply voltage (PELV), but has the same potential as the analogue outputs.*

* VLT 5001-5062, 525-600 V do not meet PELV.

Control card, RS 485 serial communication:

Terminal nos.	68 (TX+, RX+), 69 (TX-, RX-)
--------------------	------------------------------

Reliable galvanic isolation: Full galvanic isolation.

Relay outputs:¹⁾

No. of programmable relay outputs	2
Terminal nos., control card (resistive load only)	4-5 (make)
Max. terminal load (AC1) on 4-5, control card	50 V AC, 1 A, 50 VA
Max. terminal load (DC1 (IEC 947)) on 4-5, control card	25 V DC, 2 A / 50 V DC, 1 A, 50 W
Max. terminal load (DC1) on 4-5, control card for UL/cJUL applications	30 V AC, 1 A / 42.5 V DC, 1A
Terminal nos., power card (resistive and inductive load)	1-3 (break), 1-2 (make)
Max. terminal load (AC1) on 1-3, 1-2, power card	250 V AC, 2 A, 500 VA
Max. terminal load (DC1 (IEC 947)) on 1-3, 1-2, power card	25 V DC, 2 A / 50 V DC, 1A, 50 W
Min. terminal load (AC/DC) on 1-3, 1-2, power card	24 V DC, 10 mA / 24 V AC, 100 mA

1) Rated values for up to 300,000 operations.

At inductive loads the number of operations are reduced by 50%, alternatively the current can be reduced by 50%, thus the 300,000 operations are maintained.

Brake resistor terminals (only SB, EB, DE and PB units):

Terminal nos.	81, 82
--------------------	--------

External 24 Volt DC supply:

Terminal nos.	35, 36
Voltage range	24 V DC \pm 15% (max. 37 V DC for 10 sec.)
Max. voltage ripple	2 V DC
Power consumption	15 W - 50 W (50 W for start-up, 20 msec.)
Min. pre-fuse	6 Amp

Reliable galvanic isolation: Full galvanic isolation if the external 24 V DC supply is also of the PELV type.

Cable lengths, cross-sections and connectors:

Max. motor cable length, screened cable	150 m
Max. motor cable length, unscreened cable	300 m
Max. motor cable length, screened cable VLT 5011 380-500 V	100 m
Max. motor cable length, screened cable VLT 5011 525-600 V and VLT 5008, normal overload mode, 525-600 V	50 m
Max. brake cable length, screened cable	20 m
Max. loadsharing cable length, screened cable	25 m from frequency converter to DC bar.
<i>Max. cable cross-section for motor, brake and loadsharing, see Electrical data</i>	
Max. cable cross-section for 24 V external DC supply	
- VLT 5001-5027 200-240 V; VLT 5001-5102 380-500 V; VLT 5001-5062 525-600 V	4 mm ² /10 AWG
- VLT 5032-5052 200-240 V; VLT 5122-5552 380-500 V; VLT 5042-5602 525-690 V	2.5 mm ² /12 AWG
Max. cross-section for control cables	1.5 mm ² /16 AWG
Max. cross-section for serial communication	1.5 mm ² /16 AWG
<i>If UL/cUL is to be complied with, copper cable with temperature class 60/75°C must be used (VLT 5001 - 5062 380 - 500 V, 525 - 600 V and VLT 5001 - 5027 200 - 240 V).</i>	
<i>If UL/cUL is to be complied with, copper cable with temperature class 75°C must be used (VLT 5072 - 5552 380 - 500 V, VLT 5032 - 5052 200 - 240 V, VLT 5042 - 5602 525 - 690 V).</i>	
<i>Connectors are for use of both copper and aluminium cables, unless other is specified.</i>	

Accuracy of display readout (parameters 009-012):

Motor current [6] 0-140% load	Max. error: ±2.0% of rated output current
Torque % [7], -100 - 140% load	Max. error: ±5% of rated motor size
Output [8], power HP [9], 0-90% load	Max. error: ±5% of rated output

Control characteristics:

Frequency range	0 - 1000 Hz
Resolution on output frequency	±0.003 Hz
System response time	3 msec.
Speed, control range (open loop)	1:100 of synchro. speed
Speed, control range (closed loop)	1:1000 of synchro. speed
Speed, accuracy (open loop)	< 1500 rpm: max. error ± 7.5 rpm
.....	>1500 rpm: max. error of 0.5% of actual speed
Speed, accuracy (closed loop)	< 1500 rpm: max. error ± 1.5 rpm
.....	>1500 rpm: max. error of 0.1% of actual speed
Torque control accuracy (open loop)	0- 150 rpm: max. error ±20% of rated torque
.....	150-1500 rpm: max. error ±10% of rated torque
.....	>1500 rpm: max. error ±20% of rated torque
Torque control accuracy (speed feedback)	Max. error ±5% of rated torque
<i>All control characteristics are based on a 4-pole asynchronous motor</i>	

Externals:

Enclosure (dependent on power size)	IP 00, IP 20, IP 21, Nema 1, IP 54
Vibration test	0.7 g RMS 18-1000 Hz random. 3 directions for 2 hours (IEC 68-2-34/35/36)
Max. relative humidity	93 % (IEC 68-2-3) for storage/transport
Max. relative humidity	95 % non condensing (IEC 721-3-3; class 3K3) for operation
Aggressive environment (IEC 721 - 3 - 3)	Uncoated class 3C2
Aggressive environment (IEC 721 - 3 - 3)	Coated class 3C3
Ambient temperature IP 20/Nema 1 (high overload torque 160%)	Max. 45°C (24-hour average max. 40°C)
Ambient temperature IP 20/Nema 1 (normal overload torque 110%)	Max. 40°C (24-hour average max. 35°C)
Ambient temperature IP 54 (high overload torque 160%)	Max. 40°C (24-hour average max. 35°C)
Ambient temperature IP 54 (normal overload torque 110%)	Max. 40°C (24-hour average max. 35°C)
Ambient temperature IP 20/54 VLT 5011 500 V	Max. 40°C (24-hour average max. 35°C)

Ambient temperature IP 54 VLT 5042-5602, 525-690 V; and 5122-5552, 380-500 V (high overload torque 160%) Max. 45°C (24-hour average max. 40°C)

Derating for high ambient temperature, see the Design Guide

Min. ambient temperature in full operation 0°C

Min. ambient temperature at reduced performance -10°C

Temperature during storage/transport -25 - +65/70°C

Max. altitude above sea level 1000 m

Derating for altitude over 1000 m above sealevel, see the Design Guide

EMC standards applied, Emission EN 61000-6-3, EN 61000-6-4, EN 61800-3, EN 55011

EMC standards applied, Immunity EN 61000-6-2, EN 61000-4-2, EN 61000-4-3, EN 61000-4-4

EN 61000-4-5, EN 61000-4-6, VDE 0160/1990.12

See section on special conditions in the Design Guide

VLT 5001-5062, 525 - 600 V do not comply with EMC or Low Voltage Directives.

IP54 units are not intended for direct outdoor installation. The IP54 rating does not relate to other exposures as sun, icing, wind blown driving rain. Under such circumstances Danfoss recommends to install the units in an enclosure designed for these environmental conditions. Alternatively, an installation at minimum 0.5 m above surface and covered by a shed is recommended

VLT 5000 Series protection:

- Electronic motor thermal protection against overload.
- Temperature monitoring of heat-sink ensures that the frequency converter cuts out if the temperature reaches 90°C for IP 00, IP 20 and Nema 1. For IP 54, the cut-out temperature is 80°C. An overtemperature can only be reset when the temperature of the heat-sink has fallen below 60°C.

For the units mentioned below, the limits are as follows:

- VLT 5122, 380-500 V, cuts out at 75°C and can be reset if the temperature has fallen below 60°C.
 - VLT 5152, 380-500 V, cuts out at 80°C and can be reset if the temperature has fallen below 60°C.
 - VLT 5202, 380-500 V, cuts out at 95°C and can be reset if the temperature has fallen below 65°C.
 - VLT 5252, 380-500 V, cuts out at 95°C and can be reset if the temperature has fallen below 65°C.
 - VLT 5302, 380-500 V, cuts out at 105°C and can be reset if the temperature has fallen below 75°C.
 - VLT 5352-5552, 380-500 V, cut out at 85°C and can be reset if the temperature has fallen below 60°C.
 - VLT 5042-5122, 525-690 V, cut out at 75°C and can be reset if the temperature has fallen below 60°C.
 - VLT 5152, 525-690 V, cuts out at 80°C and can be reset if the temperature has fallen below 60°C.
 - VLT 5202-5352, 525-690 V, cut out at 100°C and can be reset if the temperature has fallen below 70°C.
 - VLT 5402-5602, 525-690 V, cut out at 75°C and can be reset if the temperature has fallen below 60°C.
- The frequency converter is protected against short-circuiting on motor terminals U, V, W.
 - The frequency converter is protected against earth fault on motor terminals U, V, W.
 - Monitoring of the intermediate circuit voltage ensures that the frequency converter cuts out if the intermediate circuit voltage becomes too high or too low.
 - If a motor phase is missing, the frequency converter cuts out, see parameter *234 Motor phase monitor*.
 - If there is a mains fault, the frequency converter is able to carry out a controlled deceleration.
 - If a mains phase is missing, the frequency converter will cut out when a load is placed on the motor.

■ Electrical data

■ Bookstyle and Compact, Mains supply 3 x 200 - 240 V

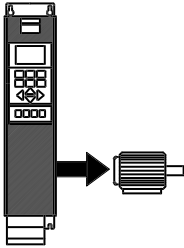
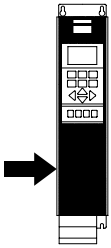
According to international requirements		VLT type	5001	5002	5003	5004	5005	5006
	Output current	I_{MTN} [A]	3.7	5.4	7.8	10.6	12.5	15.2
		$I_{MT MAX}$ (60 s) [A]	5.9	8.6	12.5	17	20	24.3
	Output (240 V)	S_{MTN} [kVA]	1.5	2.2	3.2	4.4	5.2	6.3
	Typical shaft output	P_{VITN} [kW]	0.75	1.1	1.5	2.2	3.0	3.7
	Typical shaft output	P_{VITN} [HP]	1	1.5	2	3	4	5
	Max. cable cross-section to motor, brake and loadsharing [mm ²]/[AWG] ²)		4/10	4/10	4/10	4/10	4/10	4/10
	Rated input current (200 V) I_{IN} [A]		3.4	4.8	7.1	9.5	11.5	14.5
	Max. cable cross-section power [mm ²]/[AWG] ²)		4/10	4/10	4/10	4/10	4/10	4/10
	Max. pre-fuses [-]/UL ¹⁾ [A]		16/10	16/10	16/15	25/20	25/25	35/30
	Efficiency ³⁾		0.95	0.95	0.95	0.95	0.95	0.95
	Weight IP 20 EB	[kg]	7	7	7	9	9	9.5
	Bookstyle							
	Weight IP 20 EB Compact	[kg]	8	8	8	10	10	10
	Weight IP 54 Compact	[kg]	11.5	11.5	11.5	13.5	13.5	13.5
	Power loss at max. load.	[W]	58	76	95	126	172	194
Enclosure		IP 20/ IP54	IP 20/ IP54	IP 20/ IP54	IP 20/ IP54	IP 20/ IP54	IP 20/ IP54	

1. For type of fuse see section *Fuses*.

2. American Wire Gauge.

3. Measured using 30 m screened motor cables at rated load and rated frequency.

■ Compact, Mains supply 3 x 200 - 240 V

According to international requirements		VLT type	5008	5011	5016	5022	5027
Normal overload torque (110 %):							
Output current	$I_{M,TN}$ [A]		32	46	61.2	73	88
	$I_{VLT, MAX}$ (60 s) [A]		35.2	50.6	67.3	80.3	96.8
Output (240 V)	$S_{VLT,N}$ [kVA]		13.3	19.1	25.4	30.3	36.6
Typical shaft output	$P_{VLT,N}$ [kW]		7.5	11	15	18.5	22
Typical shaft output	$P_{VLT,N}$ [HP]		10	15	20	25	30
High overload torque (160 %):							
Output current	$I_{M,TN}$ [A]		25	32	46	61.2	73
	$I_{VLT, MAX}$ (60 s) [A]		40	51.2	73.6	97.9	116.8
Output (240 V)	$S_{VLT,N}$ [kVA]		10	13	19	25	30
Typical shaft output	$P_{VLT,N}$ [kW]		5.5	7.5	11	15	18.5
Typical shaft output	$P_{VLT,N}$ [HP]		7.5	10	15	20	25
Max. cable cross-section to motor, brake and loadsharing [mm ² /AWG] ²⁾⁵⁾	IP 54		16/6	16/6	35/2	35/2	50/0
Min. cable cross-section to motor, brake and loadsharing ⁴⁾ [mm ² /AWG] ²⁾	IP 20		16/6	35/2	35/2	35/2	50/0
			10/8	10/8	10/8	10/8	16/6
<hr/>							
Rated input current (200 V) $I_{i,N}$ [A]			32	46	61	73	88
	Max. cable cross-section, power [mm ² /AWG] ²⁾⁵⁾	IP 54	16/6	16/6	35/2	35/2	50/0
		IP 20	16/6	35/2	35/2	35/2	50/0
Max. pre-fuses [-]/UL ¹⁾ [A]			50	60	80	125	125
Efficiency ³⁾			0.95	0.95	0.95	0.95	0.95
Weight IP 20 EB [kg]			21	25	27	34	36
Weight IP 54 [kg]			38	40	53	55	56
Power loss at max. load.							
- high overload torque (160 %)	[W]		340	426	626	833	994
- normal overload torque (110 %)	[W]		426	545	783	1042	1243
<hr/>							
Enclosure			IP 20/	IP 20/	IP 20/	IP 20/	IP 20/
			IP 54	IP 54	IP 54	IP 54	IP 54

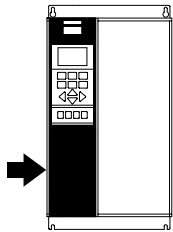
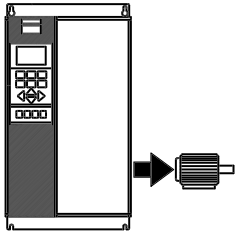

1. For type of fuse see section *Fuses*
2. American Wire Gauge.
3. Measured using 30 m screened motor cables at rated load and rated frequency.
4. Min. cable cross-section is the smallest cable cross-section allowed to be fitted on the terminals to comply with IP 20. Always comply with national and local regulations on min. cable cross-section.
5. Aluminium cables with cross-section above 35 mm² must be connected by use of a Al-Cu connector.

■ Compact, Mains supply 3 x 200 - 240 V

According to international requirements	VLT type	5032	5042	5052
Normal overload torque (110 %):				
Output current	I_{MTN} [A] (200-230 V)	115	143	170
	$I_{MT,MAX}$ (60 s) [A] (200-230 V)	127	158	187
	I_{MTN} [A] (231-240 V)	104	130	154
	$I_{MT,MAX}$ (60 s) [A] (231-240 V)	115	143	170
Output	S_{MITN} [kVA] (208 V)	41	52	61
	S_{MITN} [kVA] (230 V)	46	57	68
	S_{MITN} [kVA] (240 V)	43	54	64
Typical shaft output	[HP] (208 V)	40	50	60
Typical shaft output	[kW] (230 V)	30	37	45
High overload torque (160 %):				
Output current	I_{MTN} [A] (200-230 V)	88	115	143
	$I_{MT,MAX}$ [A] (200-230 V)	132	173	215
	I_{MTN} [A] (231-240 V)	80	104	130
	$I_{MT,MAX}$ [A] (231-240 V)	120	285	195
Output	S_{MITN} [kVA] (208 V)	32	41	52
	S_{MITN} [kVA] (230 V)	35	46	57
	S_{MITN} [kVA] (240 V)	33	43	54
Typical shaft output	[HP] (208 V)	30	40	50
	[kW] (230 V)	22	30	37
Max. cable cross-section to motor and loadsharing	[mm ²] ^{4,6}		120	
	[AWG] ^{2,4,6}		300 mcm	
Max. cable cross-section to brake	[mm ²] ^{4,6}		25	
	[AWG] ^{2,4,6}		4	
Normal overload torque (110 %):				
Rated input current	I_{IN} [A] (230 V)	101.3	126.6	149.9
Normal overload torque (150 %):				
Rated input current	I_{IN} [A] (230 V)	77.9	101.3	126.6
Max. cable cross-section	[mm ²] ^{4,6}		120	
power supply	[AWG] ^{2,4,6}		300 mcm	
Min. cable cross-section to motor, power	[mm ²] ^{4,6}		6	
	[AWG] ^{2,4,6}		8	
supply, brake and loadsharing				
Max. pre-fuses (mains) [-]/UL	[A] ¹	150/150	200/200	250/250
Efficiency ³		0.96-0.97		
Power loss	Normal overload [W]	1089	1361	1612
	High overload [W]	838	1089	1361
Weight	IP 00 [kg]	101	101	101
Weight	IP 20 Nema1 [kg]	101	101	101
Weight	IP 54 Nema12 [kg]	104	104	104
Enclosure	IP 00 / Nema 1 (IP 20) / IP 54			

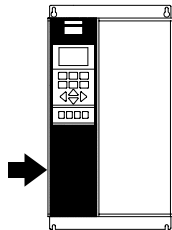
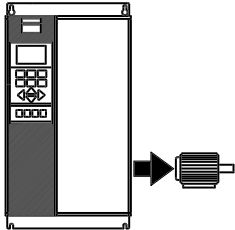

1. For type of fuse see section *Fuses*
2. American Wire Gauge.
3. Measured using 30 m screened motor cables at rated load and rated frequency.
4. Max. cable cross-section is the maximum possible cable cross-section allowed to be fitted on the terminals. Min. cable cross-section is the minimum allowed cross-section. Always comply with national and local regulations on min. cable cross-section.
5. Weight without shipping container.
6. Connection stud: M8 Brake: M6.

■ Bookstyle and Compact, Mains supply 3 x 380 - 500 V

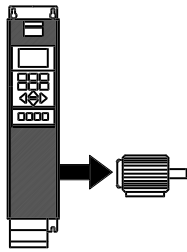
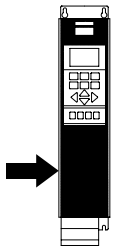
According to international requirements		VLT type	5001	5002	5003	5004	
	Output current	I_{MTN} [A] (380-440 V)	2.2	2.8	4.1	5.6	
		$I_{MT,MAX}$ (60 s) [A] (380-440 V)	3.5	4.5	6.5	9	
	Output	I_{MTN} [A] (441-500 V)	1.9	2.6	3.4	4.8	
		$I_{MT,MAX}$ (60 s) [A] (441-500 V)	3	4.2	5.5	7.7	
		S_{MITN} [kVA] (380-440 V)	1.7	2.1	3.1	4.3	
		S_{MITN} [kVA] (441-500 V)	1.6	2.3	2.9	4.2	
		Typical shaft output	P_{VITN} [kW]	0.75	1.1	1.5	2.2
		Typical shaft output	P_{VITN} [HP]	1	1.5	2	3
	Max. cable cross-section to motor, brake and loadsharing [mm ²]/[AWG] ²)			4/10	4/10	4/10	4/10
		Rated input current	I_{LN} [A] (380 V)	2.3	2.6	3.8	5.3
I_{LN} [A] (460 V)			1.9	2.5	3.4	4.8	
Max. cable cross-section, power [mm ²]/[AWG] ²)			4/10	4/10	4/10	4/10	
Max. pre-fuses [-]/UL ¹) [A]			16/6	16/6	16/10	16/10	
Efficiency ³)			0.96	0.96	0.96	0.96	
Weight IP 20 EB Bookstyle [kg]			7	7	7	7.5	
Weight IP 20 EB Compact [kg]			8	8	8	8.5	
Weight IP 54 Compact [kg]			11.5	11.5	11.5	12	
Power loss at max. load [W]			55	67	92	110	
Enclosure			IP 20/ IP 54	IP 20/ IP 54	IP 20/ IP 54	IP 20/ IP 54	

1. For type of fuse see section *Fuses*.
2. American Wire Gauge.
3. Measured using 30 m screened motor cables at rated load and rated frequency.

Bookstyle and Compact, Mains supply 3 x 380 - 500 V

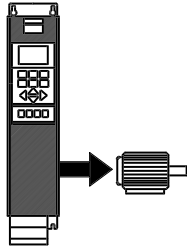
According to international requirements		VLT type	5005	5006	5008	5011	
	Output current	I_{MTN} [A] (380-440 V)	7.2	10	13	16	
		$I_{MT,MAX}$ (60 s) [A] (380-440 V)	11.5	16	20.8	25.6	
	Output	I_{MTN} [A] (441-500 V)	6.3	8.2	11	14.5	
		$I_{MT,MAX}$ (60 s) [A] (441-500 V)	10.1	13.1	17.6	23.2	
		S_{VITN} [kVA] (380-440 V)	5.5	7.6	9.9	12.2	
		S_{VITN} [kVA] (441-500 V)	5.5	7.1	9.5	12.6	
		Typical shaft output	P_{VITN} [kW]	3.0	4.0	5.5	7.5
		Typical shaft output	P_{VITN} [HP]	4	5	7.5	10
		Max. cable cross-section to motor, brake and loadsharing [mm ²]/[AWG] ²)		4/10	4/10	4/10	4/10
		Rated input current	I_{LN} [A] (380 V)	7	9.1	12.2	15.0
	I_{LN} [A] (460 V)	6	8.3	10.6	14.0		
Max. cable cross-section power [mm ²]/[AWG] ²)		4/10	4/10	4/10	4/10		
Max. pre-fuses [-]/UL ¹) [A]		16/15	25/20	25/25	35/30		
Efficiency ³)		0.96	0.96	0.96	0.96		
Weight IP 20 EB Bookstyle [kg]		7.5	9.5	9.5	9.5		
Weight IP 20 EB Compact [kg]		8.5	10.5	10.5	10.5		
Weight IP 54 EB Compact [kg]		12	14	14	14		
Power loss at max. load.	[W]	139	198	250	295		
Enclosure		IP 20/	IP 20/	IP 20/	IP 20/		
		IP 54	IP 54	IP 54	IP 54		

1. For type of fuse see section *Fuses*.
2. American Wire Gauge.
3. Measured using 30 m screened motor cables at rated load and rated frequency.

■ Compact, Mains supply 3 x 380 - 500 V

According to international requirements		VLT type	5016	5022	5027
Normal overload torque (110 %):					
Output current	I_{MTN} [A] (380-440 V)		32	37.5	44
	$I_{VLT, MAX}$ (60 s) [A] (380-440 V)		35.2	41.3	48.4
Output	$I_{VLT, N}$ [A] (441-500 V)		27.9	34	41.4
	$I_{VLT, MAX}$ (60 s) [A] (441-500 V)		30.7	37.4	45.5
Typical shaft output	S_{MTN} [kVA] (380-440 V)		24.4	28.6	33.5
	$S_{VLT, N}$ [kVA] (441-500 V)		24.2	29.4	35.8
Typical shaft output	$P_{VLT, N}$ [kW]		15	18.5	22
	$P_{VLT, N}$ [HP]		20	25	30
High overload torque (160 %):					
Output current	I_{MTN} [A] (380-440 V)		24	32	37.5
	$I_{VLT, MAX}$ (60 s) [A] (380-440 V)		38.4	51.2	60
Output	$I_{VLT, N}$ [A] (441-500 V)		21.7	27.9	34
	$I_{VLT, MAX}$ (60 s) [A] (441-500 V)		34.7	44.6	54.4
Typical shaft output	S_{MTN} [kVA] (380-440 V)		18.3	24.4	28.6
	$S_{VLT, N}$ [kVA] (441-500 V)		18.8	24.2	29.4
Typical shaft output	$P_{VLT, N}$ [kW]		11	15	18.5
	$P_{VLT, N}$ [HP]		15	20	25
Max. cable cross-section to motor, brake and loadsharing [mm ²]/[AWG] ²⁾	IP 54		16/6	16/6	16/6
	IP 20		16/6	16/6	35/2
Min. cable cross-section to motor, brake and loadsharing [mm ²]/[AWG] ^{2) 4)}			10/8	10/8	10/8
Rated input current	I_{LN} [A] (380 V)		32	37.5	44
	I_{LN} [A] (460 V)		27.6	34	41
Max. cable cross-section, power [mm ²]/[AWG]	IP 54		16/6	16/6	16/6
	IP 20		16/6	16/6	35/2
Max. pre-fuses	[-/UL ¹⁾] [A]		63/40	63/50	63/60
Efficiency ³⁾			0.96	0.96	0.96
Weight IP 20 EB	[kg]		21	22	27
Weight IP 54	[kg]		41	41	42
Power loss at max. load.					
- high overload torque (160 %)	[W]		419	559	655
- normal overload torque (110 %)	[W]		559	655	768
Enclosure			IP 20/	IP 20/	IP 20/
			IP 54	IP 54	IP 54

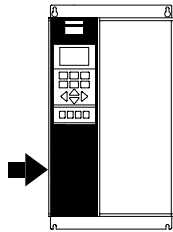
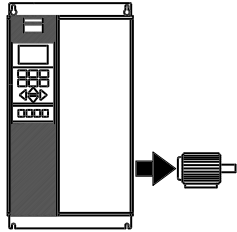

1. For type of fuse see section *Fuses*.
2. American Wire Gauge.
3. Measured using 30 m screened motor cables at rated load and rated frequency.
4. Min. cable cross-section is the smallest cable cross-section allowed to be fitted on the terminals to comply with IP 20. Always comply with national and local regulations on min. cable cross-section.

Compact, Mains supply 3 x 380 - 500 V

According to international requirements

		VLT type	5032	5042	5052
Normal overload torque (110 %):					
Output current	I_{MTN} [A] (380-440 V)		61	73	90
	$I_{VLT, MAX}$ (60 s) [A] (380-440 V)		67.1	80.3	99
Output	$I_{VLT, N}$ [A] (441-500 V)		54	65	78
	$I_{VLT, MAX}$ (60 s) [A] (441-500 V)		59.4	71.5	85.8
Output	$S_{VLT, N}$ [kVA] (380-440 V)		46.5	55.6	68.6
	$S_{VLT, N}$ [kVA] (441-500 V)		46.8	56.3	67.5
Typical shaft output	$P_{VLT, N}$ [kW]		30	37	45
Typical shaft output	$P_{VLT, N}$ [HP]		40	50	60
High overload torque (160 %):					
Output current	I_{MTN} [A] (380-440 V)		44	61	73
	$I_{VLT, MAX}$ (60 s) [A] (380-440 V)		70.4	97.6	116.8
Output	$I_{VLT, N}$ [A] (441-500 V)		41.4	54	65
	$I_{VLT, MAX}$ (60 s) [A] (441-500 V)		66.2	86	104
Output	$S_{VLT, N}$ [kVA] (380-440 V)		33.5	46.5	55.6
	$S_{VLT, N}$ [kVA] (441-500 V)		35.9	46.8	56.3
Typical shaft output	$P_{VLT, N}$ [kW]		22	30	37
Typical shaft output	$P_{VLT, N}$ [HP]		30	40	50
Max. cable cross-section to motor, brake and loadsharing [mm ²] / [AWG] ²⁾⁵⁾		IP 54	35/2	35/2	50/0
		IP20	35/2	35/2	50/0
Min. cable cross-section to motor, brake and loadsharing [mm ²] / [AWG] ²⁾⁴⁾			10/8	10/8	16/6
Rated input current	$I_{L, N}$ [A] (380 V)		60	72	89
	$I_{L, N}$ [A] (460 V)		53	64	77
Max. cable cross-section power [mm ²] / [AWG] ²⁾⁵⁾		IP 54	35/2	35/2	50/0
		IP 20	35/2	35/2	50/0
Max. pre-fuses	[-] / UL ¹⁾ [A]		80/80	100/100	125/125
Efficiency ³⁾			0.96	0.96	0.96
Weight IP 20 EB	[kg]		28	41	42
Weight IP 54	[kg]		54	56	56
Power loss at max. load.					
- high overload torque (160 %)	[W]		768	1065	1275
- normal overload torque (110 %)	[W]		1065	1275	1571
Enclosure			IP 20/	IP 20/	IP 20/
			IP 54	IP 54	IP 54

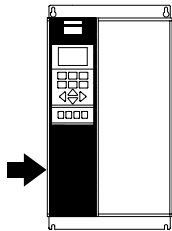
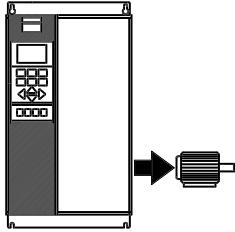

1. For type of fuse see section *Fuses*.
2. American Wire Gauge.
3. Measured using 30 m screened motor cables at rated load and rated frequency.
4. Min. cable cross-section is the smallest cable cross-section allowed to be fitted on the terminals to comply with IP 20. Always comply with national and local regulations on min. cable cross-section.
5. Aluminium cables with cross-section above 35 mm² must be connected by use of a Al-Cu connector.

Compact, Mains supply 3 x 380 - 500 V

According to international requirements

	VLT type	5062	5072	5102
Normal overload torque (110 %):				
Output current	$I_{VLT,N}$ [A] (380-440 V)	106	147	177
	$I_{VLT,MAX}$ (60 s) [A] (380-440 V)	117	162	195
	$I_{VLT,N}$ [A] (441-500 V)	106	130	160
	$I_{VLT,MAX}$ (60 s) [A] (441-500 V)	117	143	176
Output	$S_{VLT,N}$ [kVA] (380-440 V)	80.8	102	123
	$S_{VLT,N}$ [kVA] (441-500 V)	91.8	113	139
Typical shaft output	$P_{VLT,N}$ [kW] (400 V)	55	75	90
	$P_{VLT,N}$ [HP] (460 V)	75	100	125
	$P_{VLT,N}$ [kW] (500 V)	75	90	110
High overload torque (160 %):				
Output current	$I_{VLT,N}$ [A] (380-440 V)	90	106	147
	$I_{VLT,MAX}$ (60 s) [A] (380-440 V)	135	159	221
	$I_{VLT,N}$ [A] (441-500 V)	80	106	130
	$I_{VLT,MAX}$ (60 s) [A] (441-500 V)	120	159	195
Output	$S_{VLT,N}$ [kVA] (380-440 V)	68.6	73.0	102
	$S_{VLT,N}$ [kVA] (441-500 V)	69.3	92.0	113
Typical shaft output	$P_{VLT,N}$ [kW] (400 V)	45	55	75
	$P_{VLT,N}$ [HP] (460 V)	60	75	100
	$P_{VLT,N}$ [kW] (500 V)	55	75	90
Max. cable cross-section to motor,	IP 54	50/0 ⁵⁾	150/300	150/300
brake and loadsharing [mm ²]/[AWG] ²⁾	IP20	50/0 ⁵⁾	mcm ⁶⁾ 120/250	mcm ⁶⁾ 120/250
Min. cable cross-section to motor,				
brake and loadsharing [mm ²]/[AWG] ⁴⁾			16/6	25/4
Rated input current	$I_{I,N}$ [A] (380 V)	104	145	174
	$I_{I,N}$ [A] (460 V)	104	128	158
Max. cable cross-section	IP 54	50/0 ⁵⁾	150/300	150/300
power[mm ²]/[AWG] ²⁾	IP 20	50/0 ⁵⁾	mcm 120/250	mcm 120/250
Max. pre-fuses	[·]/[UL ¹⁾] [A]	160/150	225/225	250/250
Efficiency ³⁾		>0.97	>0.97	>0.97
Weight IP 20 EB	[kg]	43	54	54
Weight IP 54	[kg]	60	77	77
Power loss at max. load.				
- high overload torque (160 %)	[W]	1122	1058	1467
- normal overload torque (110 %)	[W]	1322	1467	1766
Enclosure		IP20/ IP 54	IP20/ IP 54	IP20/ IP 54

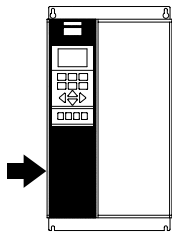
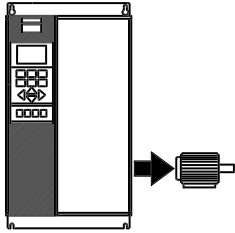

1. For type of fuse see section *Fuses*.
2. American Wire Gauge.
3. Measured using 30 m screened motor cables at rated load and rated frequency.
4. Min. cable cross-section is the smallest cable cross-section allowed to be fitted on the terminals to comply with IP 20. Always comply with national and local regulations on min. cable cross-section.
5. Aluminium cables with cross-section above 35 mm² must be connected by use of a Al-Cu connector.
6. Brake and loadsharing: 95 mm² / AWG 3/0

■ Compact, Mains supply 3 x 380 - 500 V

According to international requirements		VLT type	5122	5152	5202	5252	5302
Normal overload current (110 %):							
Output current	I_{MTN} [A] (380-440 V)		212	260	315	395	480
	$I_{VLT, MAX}$ (60 s) [A] (380-440 V)		233	286	347	434	528
	I_{MTN} [A] (441-500 V)		190	240	302	361	443
	$I_{VLT, MAX}$ (60 s) [A] (441-500 V)		209	264	332	397	487
Output	S_{MTN} [kVA] (400 V)		147	180	218	274	333
	S_{MTN} [kVA] (460 V)		151	191	241	288	353
	S_{MTN} [kVA] (500 V)		165	208	262	313	384
Typical shaft output	[kW] (400 V)		110	132	160	200	250
	[HP] (460 V)		150	200	250	300	350
	[kW] (500 V)		132	160	200	250	315
High overload torque (160 %):							
Output current	I_{MTN} [A] (380-440 V)		177	212	260	315	395
	$I_{VLT, MAX}$ (60 s) [A] (380-440 V)		266	318	390	473	593
	I_{MTN} [A] (441-500 V)		160	190	240	302	361
	$I_{VLT, MAX}$ (60 s) [A] (441-500 V)		240	285	360	453	542
Output	S_{MTN} [kVA] (400 V)		123	147	180	218	274
	S_{MTN} [kVA] (460 V)		127	151	191	241	288
	S_{MTN} [kVA] (500 V)		139	165	208	262	313
Typical shaft output	[kW] (400 V)		90	110	132	160	200
	[HP] (460 V)		125	150	200	250	300
	[kW] (500 V)		110	132	160	200	250
Max. cable cross-section to motor	[mm ²] ^{4,6}		2 x 70		2 x 185		
	[AWG] ^{2,4,6}		2 x 2/0		2 x 350 mcm		
Max. cable cross-section to loadsharing and brake	[mm ²] ^{4,6}		2 x 70		2 x 185		
	[AWG] ^{2,4,6}		2 x 2/0		2 x 350 mcm		
Normal overload current (110 %):							
Rated input current	$I_{I, N}$ [A] (380-440 V)		208	256	317	385	467
	$I_{I, N}$ [A] (441-500 V)		185	236	304	356	431
High overload torque (160 %):							
Rated input current	$I_{I, N}$ [A] (380-440 V)		174	206	256	318	389
	$I_{I, N}$ [A] (441-500 V)		158	185	236	304	356
Max. cable cross-section power supply	[mm ²] ^{4,6}		2 x 70		2 x 185		
	[AWG] ^{2,4,6}		2 x 2/0		2 x 350 mcm		
Max. pre-fuses (mains) [-]/UL	[A] ¹		300/	350/	450/	500/	630/
			300	350	400	500	600
Efficiency ³			0,98				
Power loss	Normal overload [W]		2619	3309	4163	4977	6107
	High overload [W]		2206	2619	3309	4163	4977
Weight	IP 00 [kg]		82	91	112	123	138
Weight	IP 21/Nema1 [kg]		96	104	125	136	151
Weight	IP 54/Nema12 [kg]		96	104	125	136	151
Enclosure			IP 00, IP 21/Nema 1 and IP 54/Nema12				

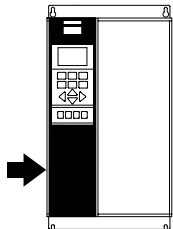
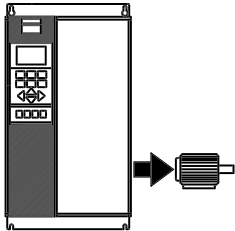

1. For type of fuse see section *Fuses*
2. American Wire Gauge.
3. Measured using 30 m screened motor cables at rated load and rated frequency.
4. Max. cable cross-section is the maximum possible cable cross-section allowed to be fitted on the terminals. Always comply with national and local regulations on min. cable cross-section.
5. Weight without shipping container.
6. Connection bolt power supply and motor: M10; Brake and loadsharing: M8

■ Compact, Mains supply 3 x 380 - 500 V

According to international requirements		VLT type	5352	5452	5502	5552
Normal overload current (110 %):						
Output current	I_{MTN} [A] (380-440 V)		600	658	745	800
	$I_{VLT, MAX}$ (60 s) [A] (380-440 V)		660	724	820	880
	I_{MTN} [A] (441-500 V)		540	590	678	730
	$I_{VLT, MAX}$ (60 s) [A] (441-500 V)		594	649	746	803
Output	S_{VLTN} [kVA] (400 V)		416	456	516	554
	S_{VLTN} [kVA] (460 V)		430	470	540	582
	S_{VLTN} [kVA] (500 V)		468	511	587	632
Typical shaft output	[kW] (400 V)		315	355	400	450
	[HP] (460 V)		450	500	550/600	600
	[kW] (500 V)		355	400	500	530
High overload torque (160 %):						
Output current	I_{MTN} [A] (380-440 V)		480	600	658	695
	$I_{VLT, MAX}$ (60 s) [A] (380-440 V)		720	900	987	1042
	I_{MTN} [A] (441-500 V)		443	540	590	678
	$I_{VLT, MAX}$ (60 s) [A] (441-500 V)		665	810	885	1017
Output	S_{VLTN} [kVA] (400 V)		333	416	456	482
	S_{VLTN} [kVA] (460 V)		353	430	470	540
	S_{VLTN} [kVA] (500 V)		384	468	511	587
Typical shaft output	[kW] (400 V)		250	315	355	400
	[HP] (460 V)		350	450	500	550
	[kW] (500 V)		315	355	400	500
Max. cable cross-section to motor and loadsharing	[mm ²] ^{4,6}			4x240		
	[AWG] ^{2,4,6}			4x500 mcm		
Max. cable cross-section to brake	[mm ²] ^{4,6}			2x185		
	[AWG] ^{2,4,6}			2x350 mcm		
Normal overload current (110 %):						
Rated input current	$I_{I, N}$ [A] (380-440 V)		590	647	733	787
	$I_{I, N}$ [A] (441-500 V)		531	580	667	718
High overload torque (160 %):						
Rated input current	$I_{I, N}$ [A] (380-440 V)		472	590	647	684
	$I_{I, N}$ [A] (441-500 V)		436	531	580	667
Max. cable cross-section power supply	[mm ²] ^{4,6}			4x240		
	[AWG] ^{2,4,6}			4x500 mcm		
Max. pre-fuses (mains) [-]/UL	[A] ¹	700/700	900/900	900/900	900/900	
Efficiency ³				0.98		
Power loss	Normal overload [W]	7630	7701	8879	9428	
	High overload [W]	6005	6960	7691	7964	
Weight	IP 00 [kg]	221	234	236	277	
	IP 21/Nema1 [kg]	263	270	272	313	
	IP 54/Nema12 [kg]	263	270	272	313	
Enclosure		IP 00, IP 21/Nema 1 and IP 54/Nema12				

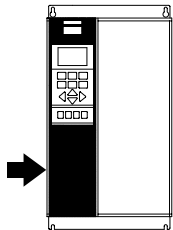
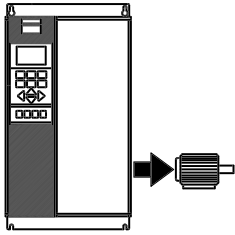

1. For type of fuse see section *Fuses*
2. American Wire Gauge.
3. Measured using 30 m screened motor cables at rated load and rated frequency.
4. Max. cable cross-section is the maximum possible cable cross-section allowed to be fitted on the terminals. Always comply with national and local regulations on min. cable cross-section.
5. Weight without shipping container.
6. Connection bolt power supply, motor and loadsharing: M10 (compression lug), 2xM8 (box lug), M8 (brake)

■ Compact, Mains supply 3 x 525 - 600 V

According to international requirements	VLT type	5001	5002	5003	5004
Normal overload torque (110 %):					
Output current	I_{MTN} [A] (550 V)	2.6	2.9	4.1	5.2
	$I_{MT,MAX}$ (60 s) [A] (550 V)	2.9	3.2	4.5	5.7
	I_{MTN} [A] (575 V)	2.4	2.7	3.9	4.9
	$I_{MT,MAX}$ (60 s) [A] (575 V)	2.6	3.0	4.3	5.4
Output	S_{VITN} [kVA] (550 V)	2.5	2.8	3.9	5.0
	S_{VITN} [kVA] (575 V)	2.4	2.7	3.9	4.9
Typical shaft output	P_{VITN} [kW]	1.1	1.5	2.2	3
Typical shaft output	P_{VITN} [HP]	1.5	2	3	4
High overload torque (160%):					
Output current	I_{MTN} [A] (550 V)	1.8	2.6	2.9	4.1
	$I_{MT,MAX}$ (60 s) [A] (550 V)	2.9	4.2	4.6	6.6
	I_{MTN} [A] (575 V)	1.7	2.4	2.7	3.9
	$I_{MT,MAX}$ (60 s) [A] (575 V)	2.7	3.8	4.3	6.2
Output	S_{VITN} [kVA] (550 V)	1.7	2.5	2.8	3.9
	S_{VITN} [kVA] (575 V)	1.7	2.4	2.7	3.9
Typical shaft output	P_{VITN} [kW]	0.75	1.1	1.5	2.2
Typical shaft output	P_{VITN} [HP]	1	1.5	2	3
Max. cable cross-section to motor, brake and loadsharing [mm ²]/[AWG] ²		4/10	4/10	4/10	4/10
Normal overload torque (110 %):					
Rated input current	I_{IN} [A] (550 V)	2.5	2.8	4.0	5.1
	I_{IN} [A] (600 V)	2.2	2.5	3.6	4.6
High overload torque (160 %):					
Rated input current	I_{IN} [A] (550 V)	1.8	2.5	2.8	4.0
	I_{IN} [A] (600 V)	1.6	2.2	2.5	3.6
Max. cable cross-section, power [mm ²]/[AWG] ²		4/10	4/10	4/10	4/10
Max. pre-fuses [-]/[UL ¹] [A]		3	4	5	6
Efficiency ³⁾		0.96	0.96	0.96	0.96
Weight IP 20 EB [kg]		10.5	10.5	10.5	10.5
Power loss at max. load. [W]		63	71	102	129
Enclosure		IP 20 / Nema 1			

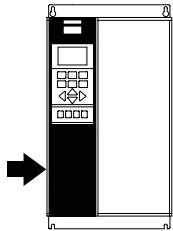
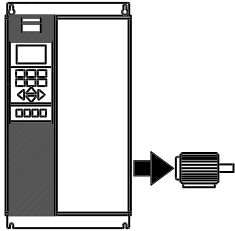

1. For type of fuses see section *Fuses*.
2. American Wire Gauge.
3. Measured using 30 m screened motor cables at rated load and rated frequency.

Compact, Mains supply 3 x 525 - 600 V

According to international requirements	VLT type	5005	5006	5008	5011
Normal overload torque (110 %):					
Output current	I_{MTN} [A] (550 V)	6.4	9.5	11.5	11.5
	$I_{MT\ MAX}$ (60 s) [A] (550 V)	7.0	10.5	12.7	12.7
	I_{MTN} [A] (575 V)	6.1	9.0	11.0	11.0
	$I_{MT\ MAX}$ (60 s) [A] (575 V)	6.7	9.9	12.1	12.1
Output	S_{VITN} [kVA] (550 V)	6.1	9.0	11.0	11.0
	S_{VITN} [kVA] (575 V)	6.1	9.0	11.0	11.0
Typical shaft output	P_{VITN} [kW]	4	5.5	7.5	7.5
Typical shaft output	P_{VITN} [HP]	5	7.5	10.0	10.0
High overload torque (160%):					
Output current	I_{MTN} [A] (550 V)	5.2	6.4	9.5	11.5
	$I_{MT\ MAX}$ (60 s) [A] (550 V)	8.3	10.2	15.2	18.4
	I_{MTN} [A] (575 V)	4.9	6.1	9.0	11.0
	$I_{MT\ MAX}$ (60 s) [A] (575 V)	7.8	9.8	14.4	17.6
Output	S_{VITN} [kVA] (550 V)	5.0	6.1	9.0	11.0
	S_{VITN} [kVA] (575 V)	4.9	6.1	9.0	11.0
Typical shaft output	P_{VITN} [kW]	3	4	5.5	7.5
Typical shaft output	P_{VITN} [HP]	4	5	7.5	10
Max. cable cross-section to motor, brake and loadsharing [mm ²]/[AWG] ²		4/10	4/10	4/10	4/10
Normal overload torque (110 %):					
Rated input current	I_{IN} [A] (550 V)	6.2	9.2	11.2	11.2
	I_{IN} [A] (600 V)	5.7	8.4	10.3	10.3
High overload torque (160 %):					
Rated input current	I_{IN} [A] (550 V)	5.1	6.2	9.2	11.2
	I_{IN} [A] (600 V)	4.6	5.7	8.4	10.3
Max. cable cross-section, power [mm ²]/[AWG] ²		4/10	4/10	4/10	4/10
Max. pre-fuses [-]/[UL ¹] [A]		8	10	15	20
Efficiency ³⁾		0.96	0.96	0.96	0.96
Weight IP 20 EB [kg]		10.5	10.5	10.5	10.5
Power loss at max. load. [W]		160	236	288	288
Enclosure		IP 20 / Nema 1			

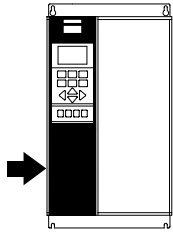
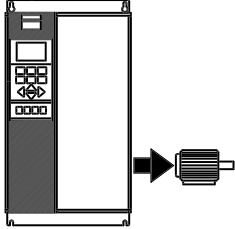

1. For type of fuses see section *Fuses*.
2. American Wire Gauge.
3. Measured using 30 m screened motor cables at rated load and rated frequency.

■ Compact, Mains supply 3 x 525 - 600 V

According to international requirements		VLT type	5016	5022	5027
Normal overload torque (110 %):					
Output current	I_{MTN} [A] (550 V)		23	28	34
	$I_{VLT, MAX}$ (60 s) [A] (550 V)		25	31	37
Output	$I_{VLT, N}$ [A] (575 V)		22	27	32
	$I_{VLT, MAX}$ (60 s) [A] (575 V)		24	30	35
	S_{VITN} [kVA] (550 V)		22	27	32
	S_{VITN} [kVA] (575 V)		22	27	32
Typical shaft output	P_{VITN} [kW]		15	18,5	22
Typical shaft output	P_{VITN} [HP]		20	25	30
High overload torque (160 %):					
Output current	I_{MTN} [A] (550 V)		18	23	28
	$I_{VLT, MAX}$ (60 s) [A] (550 V)		29	37	45
Output	$I_{VLT, N}$ [A] (575 V)		17	22	27
	$I_{VLT, MAX}$ (60 s) [A] (575 V)		27	35	43
	S_{VITN} [kVA] (550 V)		17	22	27
	S_{VITN} [kVA] (575 V)		17	22	27
Typical shaft output	P_{VITN} [kW]		11	15	18,5
Typical shaft output	P_{VITN} [HP]		15	20	25
Max. cable cross-section to motor, brake and loadsharing [mm ²]/[AWG] ²			16	16	35
Min. cable cross-section to motor, brake and loadsharing [mm ²]/[AWG] ⁴			6	6	2
			0,5	0,5	10
			20	20	8
Normal overload torque (110 %):					
Rated input current	$I_{I, N}$ [A] (550 V)		22	27	33
	$I_{I, N}$ [A] (600 V)		21	25	30
High overload torque (160 %):					
Rated input current	$I_{I, N}$ [A] (550 V)		18	22	27
	$I_{I, N}$ [A] (600 V)		16	21	25
Max. cable cross-section, power [mm ²]/[AWG] ²			16	16	35
Max. pre-fuses [-]/[UL ¹] [A]			6	6	2
Efficiency ³			30	35	45
Weight IP 20 EB [kg]			0,96	0,96	0,96
Power loss at max. load [W]			23	23	30
Enclosure			576	707	838
				IP 20 / Nema 1	

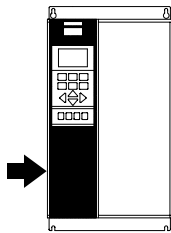
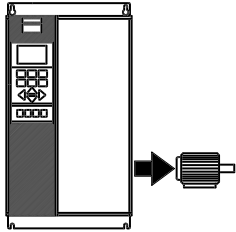

1. For type of fuse see section *Fuses*
2. American Wire Gauge.
3. Measured using 30 m screened motor cables at rated load and rated frequency.
4. Min. cable cross-section is the smallest cable cross-section allowed to be fitted on the terminals to comply with IP 20. Always comply with national and local regulations on min. cable cross-section.

Compact, Mains supply 3 x 525 - 600 V

According to international requirements

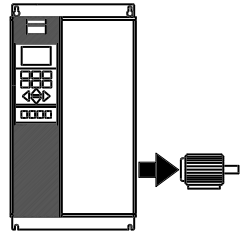

	VLT type	5032	5042	5052	5062
Normal overload torque (110 %):					
Output current	I_{MTN} [A] (550 V)	43	54	65	81
	$I_{MLT, MAX}$ (60 s) [A] (550 V)	47	59	72	89
	I_{MTN} [A] (575 V)	41	52	62	77
	$I_{MLT, MAX}$ (60 s) [A] (575 V)	45	57	68	85
Output	S_{MTN} [kVA] (550 V)	41	51	62	77
	S_{MTN} [kVA] (575 V)	41	52	62	77
Typical shaft output	P_{MTN} [kW]	30	37	45	55
Typical shaft output	P_{MTN} [HP]	40	50	60	75
High overload torque (160 %):					
Output current	I_{MTN} [A] (550 V)	34	43	54	65
	$I_{MLT, MAX}$ (60 s) [A] (550 V)	54	69	86	104
	I_{MTN} [A] (575 V)	32	41	52	62
	$I_{MLT, MAX}$ (60 s) [A] (575 V)	51	66	83	99
Output	S_{MTN} [kVA] (550 V)	32	41	51	62
	S_{MTN} [kVA] (575 V)	32	41	52	62
Typical shaft output	P_{MTN} [kW]	22	30	37	45
Typical shaft output	P_{MTN} [HP]	30	40	50	60
Max. cable cross-section to motor, brake and loadsharing [mm ²] / [AWG] ⁽²⁾⁵⁾		35	50	50	50
Min. cable cross-section to motor, brake and loadsharing [mm ²] / [AWG] ⁽⁴⁾		2	1/0	1/0	1/0
		10	16	16	16
		8	6	6	6

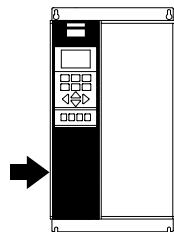

Normal overload torque (110 %):					
Rated input current	$I_{I, N}$ [A] (550 V)	42	53	63	79
	$I_{I, N}$ [A] (600 V)	38	49	58	72
High overload torque (160 %):					
Rated input current	$I_{I, N}$ [A] (550 V)	33	42	53	63
	$I_{I, N}$ [A] (600 V)	30	38	49	58
Max. cable cross-section power [mm ²] / [AWG] ^(2) 5)		35	50	50	50
		2	1/0	1/0	1/0
Max. pre-fuses [-] / [UL ⁽¹⁾] [A]		60	75	90	100
Efficiency ⁽³⁾		0.96	0.96	0.96	0.96
Weight IP 20 EB [kg]		30	48	48	48
Power loss at max. load [W]		1074	1362	1624	2016
Enclosure		IP 20 / Nema 1			

1. For type of fuse see section *Fuses*
2. American Wire Gauge.
3. Measured using 30 m screened motor cables at rated load and rated frequency.
4. Min. cable cross-section is the smallest cable cross-section allowed to be fitted on the terminals to comply with IP 20. Always comply with national and local regulations on min. cable cross-section.
5. Aluminium cables with cross-section above 35 mm² must be connected by use of a Al-Cu connector.

■ Mains supply 3 x 525 - 690 V

According to international requirements		VLT type	5042	5052	5062	5072	5102
Normal overload torque (110 %):							
Output current	I_{MTN} [A] (525-550 V)		56	76	90	113	137
	$I_{VLT, MAX}$ (60 s) [A] (525-550 V)		62	84	99	124	151
	I_{MTN} [A] (551-690 V)		54	73	86	108	131
	$I_{VLT, MAX}$ (60 s) [A] (551-690 V)		59	80	95	119	144
	S_{MTN} [kVA] (550 V)		53	72	86	108	131
	S_{MTN} [kVA] (575 V)		54	73	86	108	130
Output	S_{MTN} [kVA] (690 V)		65	87	103	129	157
	Typical shaft output						
	[kW] (550 V)		37	45	55	75	90
	[HP] (575 V)		50	60	75	100	125
	[kW] (690 V)		45	55	75	90	110
High overload torque (160 %):							
Output current	I_{MTN} [A] (525-550 V)		48	56	76	90	113
	$I_{VLT, MAX}$ (60 s) [A] (525-550 V)		77	90	122	135	170
	I_{MTN} [A] (551-690 V)		46	54	73	86	108
	$I_{VLT, MAX}$ (60 s) [A] (551-690 V)		74	86	117	129	162
	S_{MTN} [kVA] (550 V)		46	53	72	86	108
	S_{MTN} [kVA] (575 V)		46	54	73	86	108
Output	S_{MTN} [kVA] (690 V)		55	65	87	103	129
	Typical shaft output						
	[kW] (550 V)		30	37	45	55	75
	[HP] (575 V)		40	50	60	75	100
	[kW] (690 V)		37	45	55	75	90
Max. cable cross-section	[mm ²] ^{4,6}				2 x 70		
to motor	[AWG] ^{2,4,6}				2 x 2/0		
Max. cable cross-section	[mm ²] ^{4,6}				2 x 70		
to loadsharing and brake	[AWG] ^{2,4,6}				2 x 2/0		
Normal overload torque (110 %):							
Rated input current	I_{LN} [A] (550 V)		60	77	89	110	130
	I_{LN} [A] (575 V)		58	74	85	106	124
	I_{LN} [A] (690 V)		58	77	87	109	128
High overload torque (160 %):							
Rated input current	I_{LN} [A] (550 V)		53	60	77	89	110
	I_{LN} [A] (575 V)		51	58	74	85	106
	I_{LN} [A] (690 V)		50	58	77	87	109
Max. cable cross-section	[mm ²] ^{4,6}				2 x 70		
power supply	[AWG] ^{2,4,6}				2 x 2/0		
Max. pre-fuses (mains)	[A] ¹	125	160	200	200	250	
[-]/UL							
Efficiency ³		0.97	0.97	0.98	0.98	0.98	
Power loss	Normal overload [W]	1458	1717	1913	2262	2662	
	High overload [W]	1355	1459	1721	1913	2264	
Weight	IP 00 [kg]			82			
Weight	IP 21/Nema1 [kg]			96			
Weight	IP 54/Nema12 [kg]			96			
Enclosure	IP 00, IP 21/Nema 1 and IP 54/Nema12						

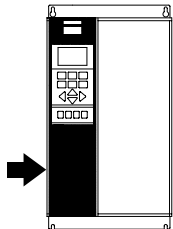
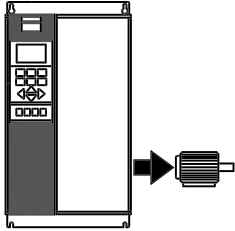

1. For type of fuse see section *Fuses*
2. American Wire Gauge.
3. Measured using 30 m screened motor cables at rated load and rated frequency.
4. Max. cable cross-section is the maximum possible cable cross-section allowed to be fitted on the terminals.
Always comply with national and local regulations on min. cable cross-section.
5. Weight without shipping container.
6. Connection bolt power supply and motor: M10; Brake and loadsharing: M8

■ mains supply 3 x 525 - 690 V

According to international requirements		VLT type	5122	5152	5202	5252	5302	5352
Normal overload torque (110 %):								
Output current	I_{MTN} [A] (525-550 V)		162	201	253	303	360	418
	$I_{VLT, MAX}$ (60 s) [A] (525-550 V)		178	221	278	333	396	460
	I_{MTN} [A] (551-690 V)		155	192	242	290	344	400
	$I_{VLT, MAX}$ (60 s) [A] (551-690 V)		171	211	266	319	378	440
	Output	S_{VLTN} [kVA] (550 V)	154	191	241	289	343	398
	S_{VLTN} [kVA] (575 V)	154	191	241	289	343	398	
Typical shaft output	S_{VLTN} [kVA] (690 V)	185	229	289	347	411	478	
	[kW] (550 V)	110	132	160	200	250	315	
	[HP] (575 V)	150	200	250	300	350	400	
	[kW] (690 V)	132	160	200	250	315	400	
	High overload torque (160 %):							
Output current	I_{MTN} [A] (525-550 V)		137	162	201	253	303	360
	$I_{VLT, MAX}$ (60 s) [A] (525-550 V)		206	243	302	380	455	540
	I_{MTN} [A] (551-690 V)		131	155	192	242	290	344
	$I_{VLT, MAX}$ (60 s) [A] (551-690 V)		197	233	288	363	435	516
	Output	S_{VLTN} [kVA] (550 V)	131	154	191	241	289	343
	S_{VLTN} [kVA] (575 V)	130	154	191	241	289	343	
Typical shaft output	S_{VLTN} [kVA] (690 V)	157	185	229	289	347	411	
	[kW] (550 V)	90	110	132	160	200	250	
	[HP] (575 V)	125	150	200	250	300	350	
	[kW] (690 V)	110	132	160	200	250	315	
	Max. cable cross-section to motor	[mm ²] ^{4,6}	2 x 70	2 x 185				
	[AWG] ^{2,4,6}	2 x 2/0	2 x 350 mcm					
Max. cable cross-section to loadsharing and brake	[mm ²] ^{4,6}	2 x 70	2 x 185					
	[AWG] ^{2,4,6}	2 x 2/0	2 x 350 mcm					
Normal overload torque (110 %):								
Rated input current	I_{LN} [A] (550 V)		158	198	245	299	355	408
	I_{LN} [A] (575 V)		151	189	234	286	339	390
	I_{LN} [A] (690 V)		155	197	240	296	352	400
High overload torque (160 %):								
Rated input current	I_{LN} [A] (550 V)		130	158	198	245	299	355
	I_{LN} [A] (575 V)		124	151	189	234	286	339
	I_{LN} [A] (690 V)		128	155	197	240	296	352
Max. cable cross-section power supply	[mm ²] ^{4,6}	2 x 70	2 x 185					
	[AWG] ^{2,4,6}	2 x 2/0	2 x 350 mcm					
Max. pre-fuses (mains)	[A] ¹	315	350	350	400	500	550	
[-]/UL								
Efficiency ³					0,98			
Power loss	Normal overload [W]		3114	3612	4292	5155	5821	6149
	High overload [W]		2664	2952	3451	4275	4875	5185
Weight	IP 00 [kg]		82	91	112	123	138	151
	IP 21/Nema1 [kg]		96	104	125	136	151	165
	IP 54/Nema12 [kg]		96	104	125	136	151	165
Enclosure			IP 00, IP 21/Nema 1 and IP 54/Nema12					

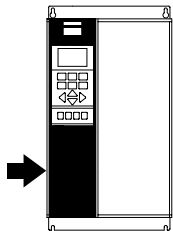
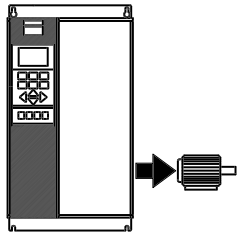

1. For type of fuse see section *Fuses*
2. American Wire Gauge.
3. Measured using 30 m screened motor cables at rated load and rated frequency.
4. Max. cable cross-section is the maximum possible cable cross-section allowed to be fitted on the terminals. Always comply with national and local regulations on min. cable cross-section.
5. Weight without shipping container.
6. Connection bolt power supply and motor: M10; Brake and loadsharing: M8

■ Compact, Mains supply 3 x 525 - 690 V

According to international requirements		VLT type	5402	5502	5602
Normal overload current (110 %):					
Output current	I_{MTN} [A] (525-550 V)		523	596	630
	$I_{MT,MAX}$ (60 s) [A] (525-550 V)		575	656	693
	I_{MTN} [A] (551-690 V)		500	570	630
	$I_{MT,MAX}$ (60 s) [A] (551-690 V)		550	627	693
Output	S_{MTN} [kVA] (550 V)		498	568	600
	S_{MTN} [kVA] (575 V)		498	568	627
	S_{MTN} [kVA] (690 V)		598	681	753
Typical shaft output	[kW] (550 V)		400	450	500
	[HP] (575 V)		500	600	650
	[kW] (690 V)		500	560	630
High overload torque (160 %):					
Output current	I_{MTN} [A] (525-550 V)		429	523	596
	$I_{MT,MAX}$ (60 s) [A] (525-550 V)		644	785	894
	I_{MTN} [A] (551-690 V)		410	500	570
	$I_{MT,MAX}$ (60 s) [A] (551-690 V)		615	750	855
Output	S_{MTN} [kVA] (550 V)		409	498	568
	S_{MTN} [kVA] (575 V)		408	498	568
	S_{MTN} [kVA] (690 V)		490	598	681
Typical shaft output	[kW] (550 V)		315	400	450
	[HP] (575 V)		400	500	600
	[kW] (690 V)		400	500	560
Max. cable cross-section	[mm ²] ^{4,6}			4x240	
to motor and loadsharing	[AWG] ^{2,4,6}			4x500 mcm	
Max. cable cross-section	[mm ²] ^{4,6}			2x185	
to brake	[AWG] ^{2,4,6}			2x350 mcm	
Normal overload current (110 %):					
Rated input current	I_{IN} [A] (525-550 V)		504	574	607
	I_{IN} [A] (551-690 V)		482	549	607
High overload torque (160 %):					
Rated input current	I_{IN} [A] (525-550 V)		413	504	574
	I_{IN} [A] (551-690 V)		395	482	549
Max. cable cross-section	[mm ²] ^{4,6}			4x240	
power supply	[AWG] ^{2,4,6}			4x500 mcm	
Max. pre-fuses (mains)	[A] ¹	700/700	900/900	900/900	
[-]/UL					
Efficiency ³				0,98	
Power loss	Normal overload [W]	7249	8727	9673	
	High overload [W]	5818	7671	8715	
Weight	IP 00 [kg]	221	236	277	
Weight	IP 21/Nema1 [kg]	263	272	313	
Weight	IP 54/Nema12 [kg]	263	272	313	
Enclosure	IP 00, IP 21/Nema 1 and IP 54/Nema12				

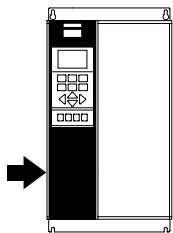
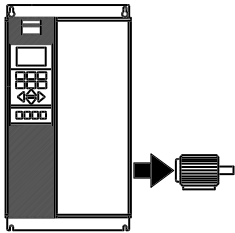

1. For type of fuse see section *Fuses*
2. American Wire Gauge.
3. Measured using 30 m screened motor cables at rated load and rated frequency.
4. Max. cable cross-section is the maximum possible cable cross-section allowed to be fitted on the terminals.
Always comply with national and local regulations on min. cable cross-section.
5. Weight without shipping container.
6. Connection bolt power supply, motor and loadsharing: M10 (compression lug), 2xM8 (box lug), M8 (brake)

■ Fuses

UL compliance

To comply with UL/cUL approvals, pre-fuses according to the table below must be used.

200-240 V

VLT	Bussmann	SIBA	Littel fuse	Ferraz-Shawmut
5001	KTN-R10	5017906-010	KLN-R10	ATM-R10 or A2K-10R
5002	KTN-R10	5017906-010	KLN-R10	ATM-R10 or A2K-10R
5003	KTN-R25	5017906-016	KLN-R15	ATM-R15 or A2K-15R
5004	KTN-R20	5017906-020	KLN-R20	ATM-R20 or A2K-20R
5005	KTN-R25	5017906-025	KLN-R25	ATM-R25 or A2K-25R
5006	KTN-R30	5012406-032	KLN-R30	ATM-R30 or A2K-30R
5008	KTN-R50	5014006-050	KLN-R50	A2K-50R
5011	KTN-R60	5014006-063	KLN-R60	A2K-60R
5016	KTN-R85	5014006-080	KLN-R80	A2K-80R
5022	KTN-R125	2028220-125	KLN-R125	A2K-125R
5027	KTN-R125	2028220-125	KLN-R125	A2K-125R
5032	KTN-R150	2028220-160	L25S-150	A25X-150
5042	KTN-R200	2028220-200	L25S-200	A25X-200
5052	KTN-R250	2028220-250	L25S-250	A25X-250

380-500 V

	Bussmann	SIBA	Littel fuse	Ferraz-Shawmut
5001	KTS-R6	5017906-006	KLS-R6	ATM-R6 or A6K-6R
5002	KTS-R6	5017906-006	KLS-R6	ATM-R6 or A6K-6R
5003	KTS-R10	5017906-010	KLS-R10	ATM-R10 or A6K-10R
5004	KTS-R10	5017906-010	KLS-R10	ATM-R10 or A6K-10R
5005	KTS-R15	5017906-016	KLS-R16	ATM-R16 or A6K-16R
5006	KTS-R20	5017906-020	KLS-R20	ATM-R20 or A6K-20R
5008	KTS-R25	5017906-025	KLS-R25	ATM-R25 or A6K-25R
5011	KTS-R30	5012406-032	KLS-R30	A6K-30R
5016	KTS-R40	5012406-040	KLS-R40	A6K-40R
5022	KTS-R50	5014006-050	KLS-R50	A6K-50R
5027	KTS-R60	5014006-063	KLS-R60	A6K-60R
5032	KTS-R80	2028220-100	KLS-R80	A6K-180R
5042	KTS-R100	2028220-125	KLS-R100	A6K-100R
5052	KTS-R125	2028220-125	KLS-R125	A6K-125R
5062	KTS-R150	2028220-160	KLS-R150	A6K-150R
5072	FWH-220	2028220-200	L50S-225	A50-P225
5102	FWH-250	2028220-250	L50S-250	A50-P250
5122*	FWH-300/170M3017	2028220-315	L50S-300	A50-P300
5152*	FWH-350/170M3018	2028220-315	L50S-350	A50-P350
5202*	FWH-400/170M4012	206xx32-400	L50S-400	A50-P400
5252*	FWH-500/170M4014	206xx32-500	L50S-500	A50-P500
5302*	FWH-600/170M4016	206xx32-600	L50S-600	A50-P600
5352	170M4017	2061032,700		6.9URD31D08A0700
5452	170M6013	2063032,900		6.9URD33D08A0900
5502	170M6013	2063032,900		6.9URD33D08A0900
5552	170M6013	2063032,900		6.9URD33D08A0900

* Circuit Breakers manufactured by General Electric, Cat. No. SKHA36AT0800, with rating plugs listed below can be used to meet UL-requirements:

5122	rating plug No.	SRPK800 A 300
5152	rating plug No.	SRPK800 A 400
5202	rating plug No.	SRPK800 A 400
5252	rating plug No.	SRPK800 A 500
5302	rating plug No.	SRPK800 A 600

525-600 V

	Bussmann	SIBA	Littel fuse	Ferraz-Shawmut
5001	KTS-R3	5017906-004	KLS-R003	A6K-3R
5002	KTS-R4	5017906-004	KLS-R004	A6K-4R
5003	KT-R5	5017906-005	KLS-R005	A6K-5R
5004	KTS-R6	5017906-006	KLS-R006	A6K-6R
5005	KTS-R8	5017906-008	KLS-R008	A6K-8R
5006	KTS-R10	5017906-010	KLS-R010	A6K-10R
5008	KTS-R15	5017906-016	KLS-R015	A6K-15R
5011	KTS-R20	5017906-020	KLS-R020	A6K-20R
5016	KTS-R30	5017906-030	KLS-R030	A6K-30R
5022	KTS-R35	5014006-040	KLS-R035	A6K-35R
5027	KTS-R45	5014006-050	KLS-R045	A6K-45R
5032	KTS-R60	5014006-063	KLS-R060	A6K-60R
5042	KTS-R75	5014006-080	KLS-R075	A6K-80R
5052	KTS-R90	5014006-100	KLS-R090	A6K-90R
5062	KTS-R100	5014006-100	KLS-R100	A6K-100R

525-600 V (UL) and 525-690 V (CE) drives

	Bussmann	SIBA	FERRAZ-SHAWMUT
5042	170M3013	2061032,125	6.6URD30D08A0125
5052	170M3014	2061032,16	6.6URD30D08A0160
5062	170M3015	2061032,2	6.6URD30D08A0200
5072	170M3015	2061032,2	6.6URD30D08A0200
5102	170M3016	2061032,25	6.6URD30D08A0250
5122	170M3017	2061032,315	6.6URD30D08A0315
5152	170M3018	2061032,35	6.6URD30D08A0350
5202	170M4011	2061032,35	6.6URD30D08A0350
5252	170M4012	2061032,4	6.6URD30D08A0400
5302	170M4014	2061032,5	6.6URD30D08A0500
5352	170M5011	2062032,55	6.6URD32D08A550
5402	170M4017	2061032,700	6.9URD31D08A0700
5502	170M6013	2063032,900	6.9URD33D08A0900
5602	170M6013	2063032,900	6.9URD33D08A0900

KTS-fuses from Bussmann may substitute KTN for 240 V drives.

FWH-fuses from Bussmann may substitute FWX for 240 V drives.

KLSR fuses from LITTEL FUSE may substitute KLNR fuses for 240 V drives.

L50S fuses from LITTEL FUSE may substitute L25S fuses for 240 V drives.

A6KR fuses from FERRAZ SHAWMUT may substitute A2KR for 240 V drives.

A50X fuses from FERRAZ SHAWMUT may substitute A25X for 240 V drives.

Non UL compliance

If UL/cUL is not to be complied with, we recommend the above mentioned fuses or:

VLT 5001-5027	200-240 V	type gG
VLT 5032-5052	200-240 V	type gR
VLT 5001-5062	380-500 V	type gG
VLT 5072-5102	380-500 V	type gR
VLT 5122-5302	380-500 V	type gG
VLT 5352-5552	380-500 V	type gR
VLT 5001-5062	525-600 V	type gG

Not following the recommendation may result in unnecessary damage of the drive in case of malfunction. Fuses must be designed for protection in a circuit capable of supplying a maximum of 100000 A_{rms} (symmetrical), 500/600 V maximum.

■ Mechanical dimensions

All the below listed measurements are in mm.

	A	B	C	D	a	b	ab/be	Type
Bookstyle IP 20								
5001 - 5003 200 - 240 V								
5001 - 5005 380 - 500 V	395	90	260		384	70	100	A
5004 - 5006 200 - 240 V								
5006 - 5011 380 - 500 V	395	130	260		384	70	100	A
Compact IP 00								
5032 - 5052 200 - 240 V	800	370	335		780	270	225	B
5122 - 5152 380 - 500 V	1046	408	373 ¹⁾		1001	304	225	J
5202 - 5302 380 - 500 V	1327	408	373 ¹⁾		1282	304	225	J
5352 - 5552 380 - 500 V	1547	585	494 ¹⁾		1502	304	225	I
5042 - 5152 525 - 690 V	1046	408	373 ¹⁾		1001	304	225	J
5202 - 5352 525 - 690 V	1327	408	373 ¹⁾		1282	304	225	J
5402 - 5602 525 - 690 V	1547	585	494 ¹⁾		1502	304	225	I
Compact IP 20								
5001 - 5003 200 - 240 V								
5001 - 5005 380 - 500 V	395	220	160		384	200	100	C
5004 - 5006 200 - 240 V								
5006 - 5011 380 - 500 V	395	220	200		384	200	100	C
5001 - 5011 525 - 600 V (IP 20 and Nema 1)								
5008 200 - 240 V								
5016 - 5022 380 - 500 V	560	242	260		540	200	200	D
5016 - 5022 525 - 600 V (Nema 1)								
5011 - 5016 200 - 240 V								
5027 - 5032 380 - 500 V	700	242	260		680	200	200	D
5027 - 5032 525 - 600 V (Nema 1)								
5022 - 5027 200 - 240 V								
5042 - 5062 380 - 500 V	800	308	296		780	270	200	D
5042 - 5062 525 - 600 V (Nema 1)								
5072 - 5102 380 - 500 V	800	370	335		780	330	225	D
Compact Nema 1/IP20/IP21								
5032 - 5052 200 - 240 V	954	370	335		780	270	225	E
5122 - 5152 380 - 500 V	1208	420	373 ¹⁾		1154	304	225	J
5202 - 5302 380 - 500 V	1588	420	373 ¹⁾		1535	304	225	J
5352 - 5552 380 - 500 V	2000	600	494 ¹⁾		-	-	225	H
5042 - 5152 525 - 690 V	1208	420	373 ¹⁾		1154	304	225	J
5202 - 5352 525 - 690 V	1588	420	373 ¹⁾		1535	304	225	J
5402 - 5602 525 - 690 V	2000	600	494 ¹⁾		-	-	225	H
Compact IP 54/Nema 12								
5001 - 5003 200 - 240 V								
5001 - 5005 380 - 500 V	460	282	195	85	260	258	100	F
5004 - 5006 200 - 240 V								
5006 - 5011 380 - 500 V	530	282	195	85	330	258	100	F
5008 - 5011 200 - 240 V								
5016 - 5027 380 - 500 V	810	350	280	70	560	326	200	F
5016 - 5027 200 - 240 V								
5032 - 5062 380 - 500 V	940	400	280	70	690	375	200	F
5032 - 5052 200 - 240 V	937	495	421	-	830	374	225	G
5072 - 5102 380 - 500 V	940	400	360	70	690	375	225	F
5122 - 5152 380 - 500 V	1208	420	373 ¹⁾	-	1154	304	225	J
5202 - 5302 380 - 500 V	1588	420	373 ²⁾	-	1535	304	225	J
5352 - 5552 380 - 500 V	2000	600	494 ¹⁾	-	-	-	225	H
5042 - 5152 525 - 690 V	1208	420	373 ¹⁾	-	1154	304	225	J
5202 - 5352 525 - 690 V	1588	420	373 ¹⁾	-	1535	304	225	J
5402 - 5602 525 - 690 V	2000	600	494 ¹⁾	-	-	-	225	H

ab: Minimum space above enclosure'

be: Minimum space below enclosure

1) With disconnect, add 44 mm.

■ Mechanical dimensions, cont.

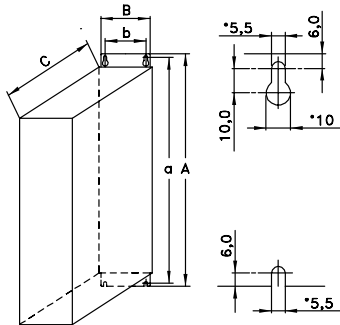

Type A, IP20

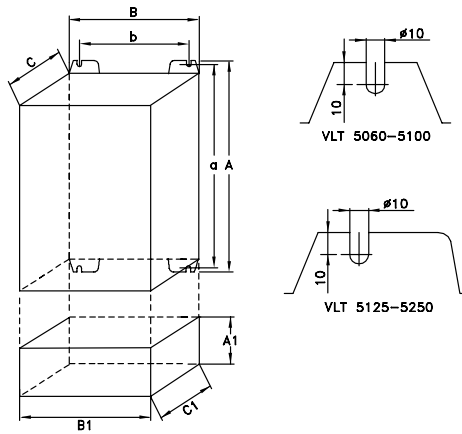

Type B, IP00
With option and enclosure IP20

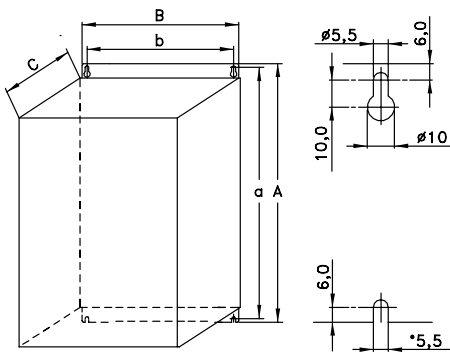

Type C, IP20

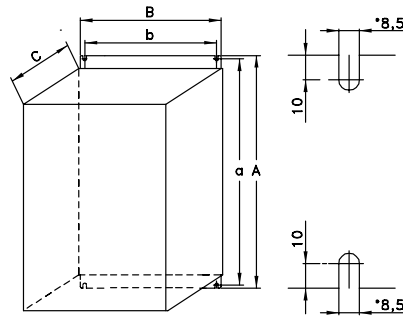

Type D, IP20

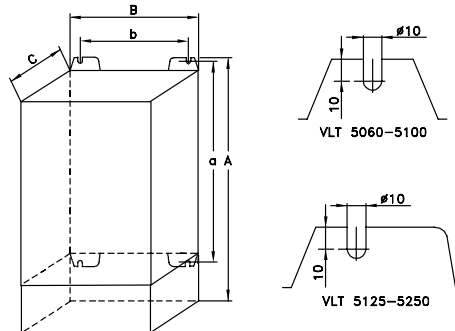

Type E, IP20/NEMA 1 with terminals

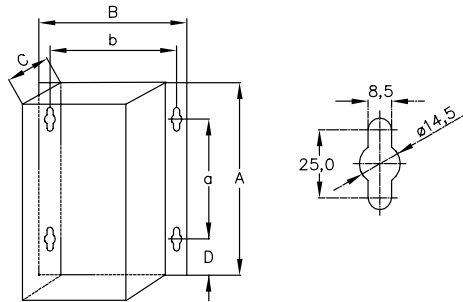

Type F, IP54

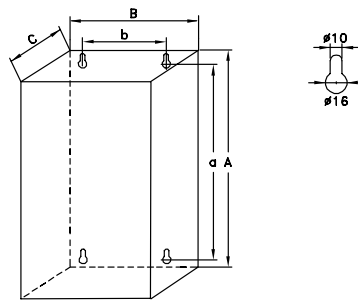

Type G, IP54

175ZA577.12

Measurements,
dimensions

■ Mechanical dimensions (cont.)

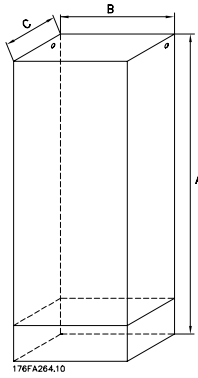

Type H, IP 20, IP 54

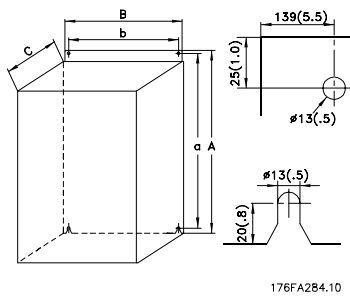

Type I, IP 00

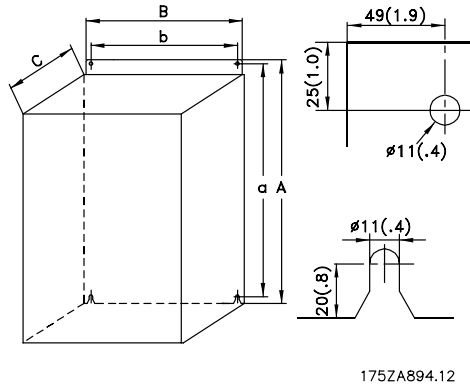

Type J, IP 00, IP 21, IP 54

■ Mechanical installation



Please pay attention to the requirements that apply to integration and field mounting kit, see the below list. The information given in the list must be observed to avoid serious damage or injury, especially when installing large units.

The frequency converter *must* be installed vertically.

The frequency converter is cooled by means of air circulation. For the unit to be able to release its cooling air, the *minimum* distance over and below the unit must be as shown in the illustration below.

To protect the unit from overheating, it must be ensured that the ambient temperature *does not rise above the max. temperature stated for the frequency converter* and that the 24-hour average temperature *is not exceeded* . The max. temperature and 24-hour average can be seen from the *General Technical Data*. If the ambient temperature is in the range of 45°C -55° C, derating of the frequency converter will become relevant, see *Derating for ambient temperature*.

The service life of the frequency converter will be reduced if derating for ambient temperature is not taken into account.

■ Installation of VLT 5001-5602

All frequency converters must be installed in a way that ensures proper cooling.

Cooling

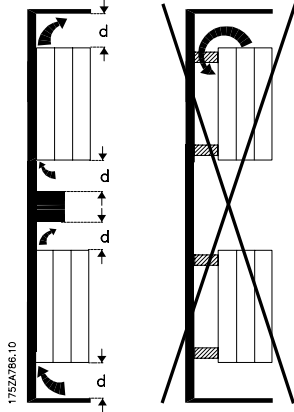

All Bookstyle and Compact units require a minimum space above and below the enclosure.

Side by side/flange by flange

All frequency converters can be mounted side by side/flange by flange.

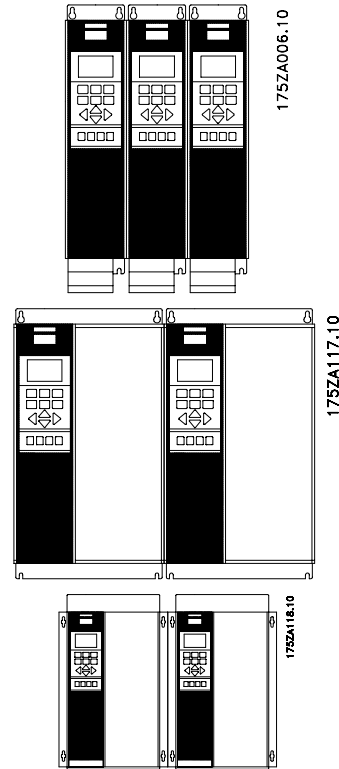

	d [mm]	Comments
Bookstyle		
VLT 5001-5006, 200-240 V	100	Installation on a plane, vertical surface (no spacers)
VLT 5001-5011, 380-500 V	100	
Compact (all enclosure types)		
VLT 5001-5006, 200-240 V	100	Installation on a plane, vertical surface (no spacers)
VLT 5001-5011, 380-500 V	100	
VLT 5001-5011, 525-600 V	100	
VLT 5008-5027, 200-240 V	200	Installation on a plane, vertical surface (no spacers)
VLT 5016-5062, 380-500 V	200	
VLT 5072-5102, 380-500 V	225	
VLT 5016-5062, 525-600 V	200	
VLT 5032-5052, 200-240 V	225	Installation on a plane, vertical surface (no spacers) IP 54 filter mats must be changed when they are dirty.
VLT 5122-5302, 380-500 V	225	
VLT 5042-5352, 525-690 V	225	
VLT 5352-5552, 380-500 V	225	
VLT 5402-5602, 525-690 V	225	
		IP 00 above and below enclosure
		IP 21/IP 54 only above enclosure

■ Installation of VLT 5352-5552 380-500 V
and VLT 5402-5602 525-690 V Compact
Nema 1 (IP 21) and IP 54
Cooling

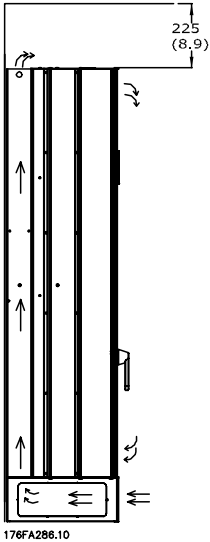

Side-by-side

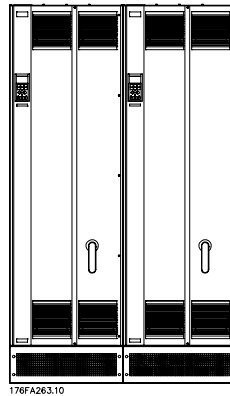

Compact Nema 1 (IP 21) and IP 54

All Nema 1 (IP 21) and IP 54 units in the above-mentioned series can be installed side by side without any space between them, since these units do not require cooling on the sides.

All units in the above-mentioned series require a minimum space of 225 mm above the enclosure and must be installed on a flat level surface. This applies to both Nema 1 (IP 21) and IP 54 units. Gaining access requires a minimum space of 579 mm in front of the frequency converter.

Filter mats in IP 54 units have to be changed regularly depending on the operating environment.

■ Electrical installation



The voltage on the frequency converter is dangerous when the unit is connected to mains. Incorrect installation of the motor or the frequency converter may lead to material damage or serious injury or it may be fatal. Consequently, the instructions in this manual as well as national and local rules and safety regulations must be complied with. Touching the electrical parts may be fatal, even after the mains supply has been disconnected.

Using VLT 5001-5006, 200-240 V and 380-500

V: wait at least 4 minutes.

Using VLT 5008-5052, 200-240 V: wait at least 15 minutes.

Using VLT 5008-5062, 380-500 V: wait at least 15 minutes.

Using VLT 5072-5302, 380-500 V: wait at least 20 minutes.

Using VLT 5352-5552, 380-500 V: wait at least 40 minutes.

Using VLT 5001-5005, 525-600 V: wait at least 4 minutes.

Using VLT 5006-5022, 525-600 V: wait at least 15 minutes.

Using VLT 5027-5062, 525-600 V: wait at least 30 minutes.

Using VLT 5042-5352, 525-690 V: wait at least 20 minutes.

Using VLT 5402-5602, 525-690 V: wait at least 30 minutes.



NB!:

It is the user's or certified electrician's responsibility to ensure correct earthing and protection in accordance with applicable national and local norms and standards.

■ High voltage test

A high voltage test can be carried out by short-circuiting terminals U, V, W, L₁, L₂ and L₃ and energizing by max. 2.15 kV DC for one second between this short-circuit and the chassis.



NB!:

The RFI switch must be closed (position ON) when high voltage tests are carried out (see section *RFI Switch*).

The mains and motor connection must be interrupted in the case of high voltage tests of the total installation if the leakage currents are too high.

■ Safety earthing



NB!:

The frequency converter has a high leakage current and must be earthed appropriately for safety reasons. Use earth terminal (see section *Electrical installation, power cables*), which enables reinforced earthing. Apply national safety regulations.

■ Extra protection (RCD)

ELCB relays, multiple protective earthing or earthing can be used as extra protection, provided that local safety regulations are complied with.

In the case of an earth fault, a DC content may develop in the faulty current.

If ELCB relays are used, local regulations must be observed. Relays must be suitable for protection of 3-phase equipment with a bridge rectifier and for a brief discharge on power-up.

See also the section *Special Conditions* in the Design Guide.

■ Electrical installation - mains supply

Connect the three mains phases to terminals L₁, L₂, L₃.

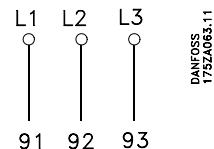

■ Electrical installation - motor cables



NB!:

If an unscreened cable is used, some EMC requirements are not complied with, see the Design Guide.

If the EMC specifications regarding emission are to be complied with, the motor cable must be screened, unless otherwise stated for the RFI filter in question. It is important to keep the motor cable as short as possible so as to reduce the noise level and leakage currents to a minimum.

The motor cable screen must be connected to the metal cabinet of the frequency converter and to the metal cabinet of the motor. The screen connections are to be made with the biggest possible surface (cable clamp). This is enabled by different installation devices in the different frequency converters.

Installation with twisted screen ends (pigtailed) is to be avoided, since these spoil the screening effect at higher frequencies.

If it is necessary to break the screen to install a motor isolator or motor contactor, the screen must be continued at the lowest possible HF impedance.

The frequency converter has been tested with a given length of cable and a given cross-section of that cable. If the cross-section is increased, the cable capacitance - and thus the leakage current - increases, and the cable length must be reduced correspondingly.

When frequency converters are used together with LC filters to reduce the acoustic noise from a motor, the switching frequency must be set according to the LC filter instruction in *Parameter 411*. When setting the switching frequency higher than 3 kHz, the output current is derated in SFAVM mode. By changing *Parameter 446* to 60° AVM mode, the frequency at which the current is derated is moved upwards. Please see *Design Guide*.

■ Connection of motor

All types of 3-phased asynchronous standard motors can be used with the VLT 5000 Series.

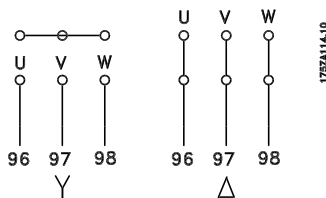

Normally, small motors are star-connected (200/400 V, Δ/Y).

Large motors are delta-connected (400/690 V, Δ/Y).

■ Direction of motor rotation

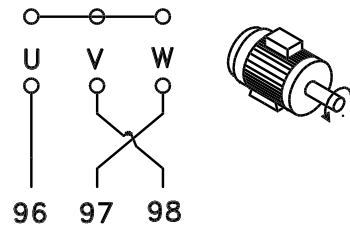
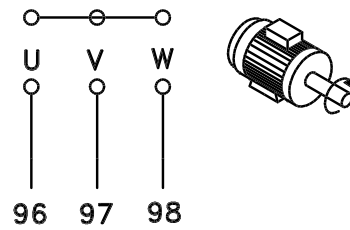

The factory setting is for clockwise rotation with the frequency transformer output connected as follows.

- Terminal 96 connected to U-phase
- Terminal 97 connected to V-phase
- Terminal 98 connected to W-phase

The direction of motor rotation can be changed by switching two phases in the motor cable.

■ Parallel coupling of motors

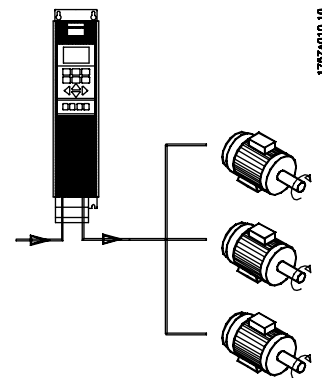

Frequency converters are able to control several motors connected in parallel. If the motors are to have different rpm values, the motors must have different rated rpm values. Motor rpm is changed simultaneously, which means that the ratio between the rated rpm values is maintained across the range.

The total current consumption of the motors is not to exceed the maximum rated output current $I_{VLT,N}$ for the frequency converter.

Problems may arise at the start and at low rpm values if the motor sizes are widely different. This is because the

Electrical installation

relatively high ohmic resistance in small motors calls for a higher voltage at the start and at low rpm values.

In systems with motors connected in parallel, the electronic thermal relay (ETR) of the frequency converter cannot be used as motor protection for the individual motor. Consequently, additional motor protection is required, such as thermistors in each motor (or individual thermal relays) suitable for frequency converter use.

Please note that the individual motor cable for each motor must be summed and is not to exceed the total motor cable length permitted.

Motor thermal protection

The electronic thermal relay in UL-approved frequency converters has received the UL-approval for single motor protection when parameter 128 has been set for *ETR Trip* and parameter 105 has been programmed to the rated motor current (see motor nameplate).

Electrical installation - brake cable

(Only standard with brake and extended with brake. Typecode: SB, EB, DE, PB).

No.	Function
81, 82	Brake resistor terminals

The connection cable to the brake resistor must be screened. Connect the screen by means of cable clamps to the conductive back plate at the frequency converter and to the metal cabinet of the brake resistor. Size the brake cable cross-section to match the brake torque. See also Brake instructions, MI.90.FX.YY and MI.50.SX.YY for further information regarding safe installation.



NB!

Please note that voltages up to 1099 V DC, depending on the supply voltage, may occur on the terminals.

Electrical installation - brake resistor temperature switch

Torque: 0.5-0.6 Nm
Screw size: M3

No.	Function
106, 104, 105	Brake resistor temperature switch.



NB!

This function is only available on VLT 5032-5052, 200-240 V; VLT 5122-5552, 380-500 V; and VLT 5042-5602, 525-690 V.

If the temperature of the brake resistor gets too high and the thermal switch drops out, the frequency converter will stop braking. The motor will start coasting. A KLIXON switch must be installed that is 'normally closed'. If this function is not used, 106 and 104 must be short-circuited together.

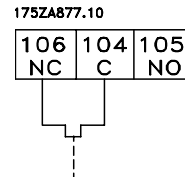

Electrical installation - loadsharing

(Only extended with typecode EB, EX, DE, DX).

No.	Function
88, 89	Loadsharing

Terminals for loadsharing

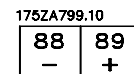

The connection cable must be screened and the max. length from the frequency converter to the DC bar is 25 metres.

Load sharing enables linking of the DC intermediate circuits of several frequency converters.



NB!

Please note that voltages up to 1099 V DC may occur on the terminals.

Load sharing calls for extra equipment. For further information please consult Loadsharing Instructions MI.50.NX.XX.

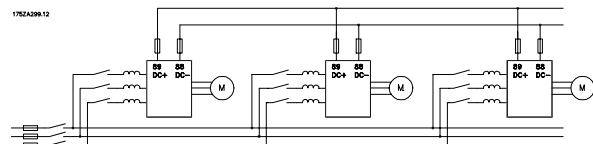

Tightening-up torques and screw sizes

The table shows the torque required when fitting terminals to the frequency converter. For VLT 5001-5027 200-240 V, VLT 5001-5102 380-500 V and VLT 5001-5062 525-600 V, the cables must be fastened with screws. For VLT 5032 - 5052 200-240 V, VLT 5122-5552 380-500 V, VLT 5042-5602 525-690 V the cables must be fastened with bolts.

These figures apply to the following terminals:

Mains terminals	Nos	91, 92, 93 L1, L2, L3
Motor terminals	Nos	96, 97, 98 U, V, W
Earth terminal	No	94, 95, 99
Brake resistor terminals		81, 82
Loadsharing		88, 89

VLT type		Torque [Nm]	Screw/ Boltsize	Tool
200-240 V				
5001-5006		0,6	M3	Slotted screw
5008	IP20	1,8	M4	Slotted screw
5008-5011	IP54	1,8	M4	Slotted screw
5011-5022	IP20	3	M5	4 mm Allen wrench
5016-5022 ³⁾	IP54	3	M5	4 mm Allen wrench
5027		6	M6	4 mm Allen wrench
5032-5052		11,3	M8 (bolt and stud)	
380-500 V				
5001-5011		0,6	M3	Slotted screw
5016-5022	IP20	1,8	M4	Slotted screw
5016-5027	IP54	1,8	M4	Slotted screw
5027-5042	IP20	3	M5	4 mm Allen wrench
5032-5042 ³⁾	IP54	3	M5	4 mm Allen wrench
5052-5062		6	M6	5 mm Allen wrench
5072-5102	IP20	15	M6	6 mm Allen wrench
	IP54 ²⁾	24	M8	8 mm Allen wrench
5122-5302 ⁴⁾		19	M10 bolt	16 mm wrench
5352-5552 ⁵⁾		19	M10 bolt (compression lug)	16 mm wrench
525-600 V				
5001-5011		0,6	M3	Slotted screw
5016-5027		1,8	M4	Slotted screw
5032-5042		3	M5	4 mm Allen wrench
5052-5062		6	M6	5 mm Allen wrench
525-690 V				
5042-5352 ⁴⁾		19	M10 bolt	16 mm wrench
5402-5602 ⁵⁾		19	M10 bolt (compression lug)	16 mm wrench

- 1) Brake terminals: 3,0 Nm, Nut: M6
- 2) Brake and loadsharing: 14 Nm, M6 Allen screw
- 3) IP54 with RFI - Line terminals 6Nm, Screw: M6 - 5 mm Allen wrench
- 4) Loadsharing and brake terminals: 9,5 Nm; Bolt M8
- 5) Brake terminals: 9,5 Nm; Bolt M8.

Electrical installation

■ Electrical installation - external fan supply

Torque 0,5-0,6 Nm

Screwsize: M3

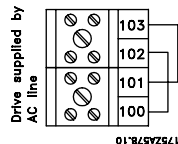
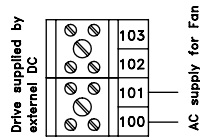

Available in 5122-5552, 380-500 V; 5042-5602, 525-690 V, 5032-5052, 200-240 V in all enclosure types.

Only for IP54 units in the power range VLT 5016-5102, 380-500 V and VLT 5008-5027, 200-240 V AC. If the drive is supplied by the DC bus (loadsharing), the internal fans are not supplied with AC power. In this case they must be supplied with an external AC supply.

■ Electrical installation - relay outputs

Torque: 0.5 - 0.6 Nm

Screw size: M3

No.	Function
1-3	Relay output, 1+3 break, 1+2 make See parameter 323 of the Operating Instructions. See also <i>General technical data</i> .
4, 5	Relay output, 4+5 make See parameter 326 of the Operating Instructions. See also <i>General technical data</i> .

■ Electrical installation - 24 Volt external DC supply

(Only extended versions. Typecode: PS, PB, PD, PF, DE, DX, EB, EX).

Torque: 0.5 - 0.6 Nm

Screw size: M3

No.	Function
35, 36	24 V external DC supply

External 24 V DC supply can be used as low-voltage supply to the control card and any option cards installed. This enables full operation of the LCP (incl. parameter setting) without connection to mains. Please note that a warning of low voltage will be given when 24 V DC has been connected; however, there will be no tripping. If 24 V external DC supply is connected or switched on at the same time as the mains supply, a time of min. 200 msec. must be set in parameter 120 *Start delay*. A pre-fuse of min. 6 Amp, slow-blow, can be fitted to protect the external 24 V DC supply. The power consumption is 15-50 W, depending on the load on the control card.



NB!:

Use 24 V DC supply of type PELV to ensure correct galvanic isolation (type PELV) on the control terminals of the frequency converter.

■ Electrical installation, power cables

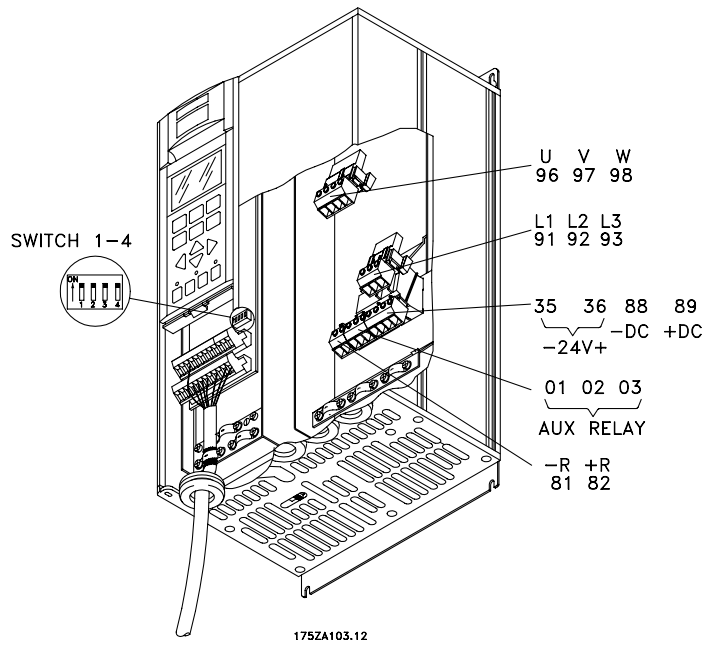
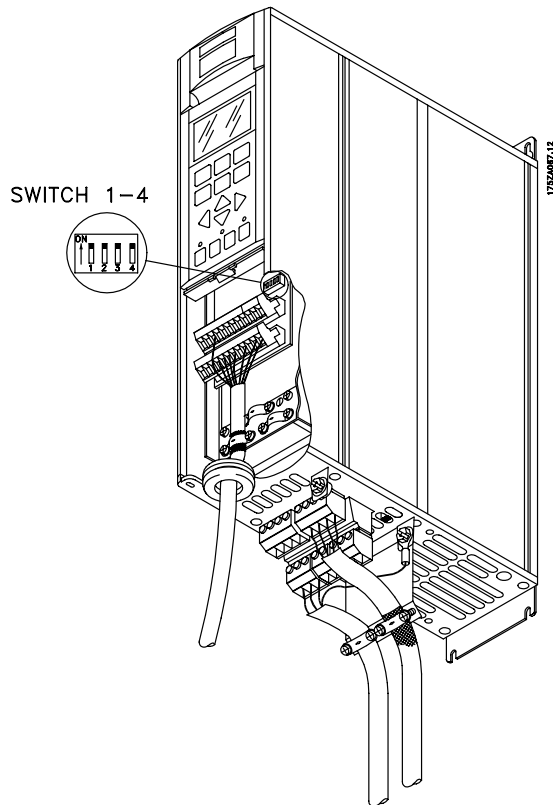

Bookstyle
VLT 5001-5006 200-240 V
VLT 5001-5011 380-500 V

Compact IP 20/Nema 1

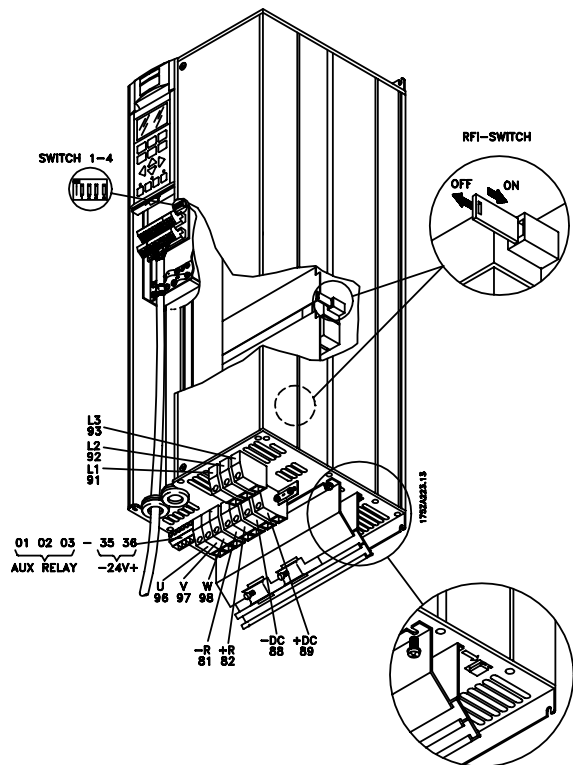
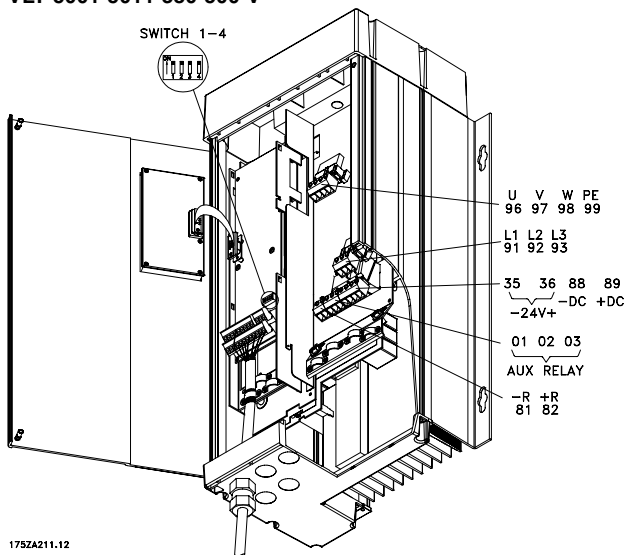

Compact IP 54
VLT 5001-5006 200-240 V
VLT 5001-5011 380-500 V
VLT 5001-5011 525-600 V

Compact IP 20/Nema 1
VLT 5008-5027 200-240 V
VLT 5016-5062 380-500 V
VLT 5016-5062 525-600 V

Electrical installation

VLT 5000 Design Guide

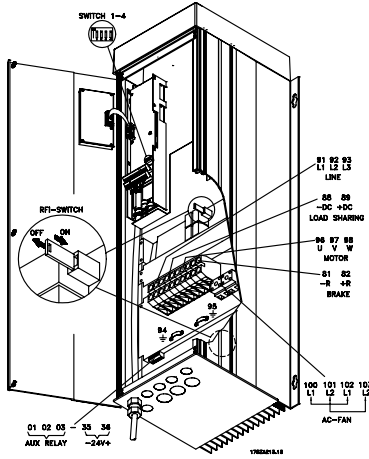

Compact IP 54
VLT 5008-5027 200-240 V
VLT 5016-5062 380-500 V

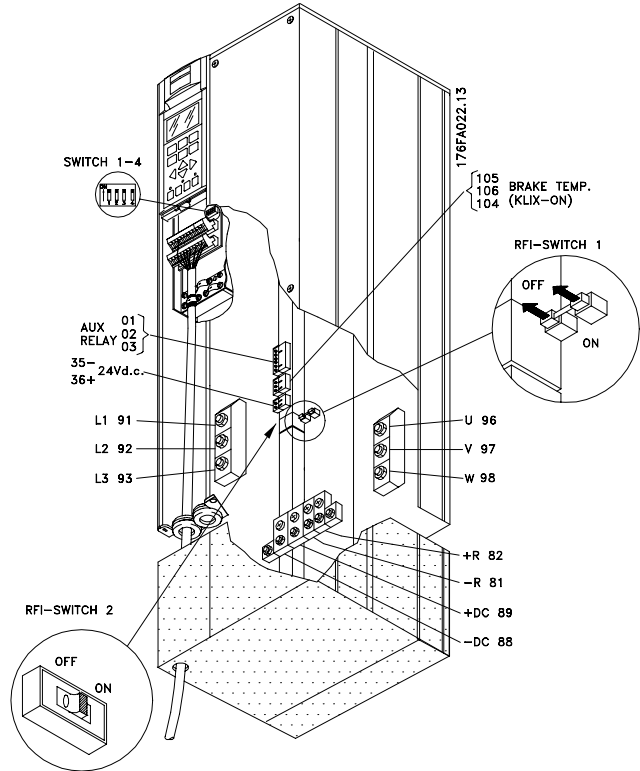

Compact IP 00/NEMA 1 (IP 20)
VLT 5032-5052 200-240 V

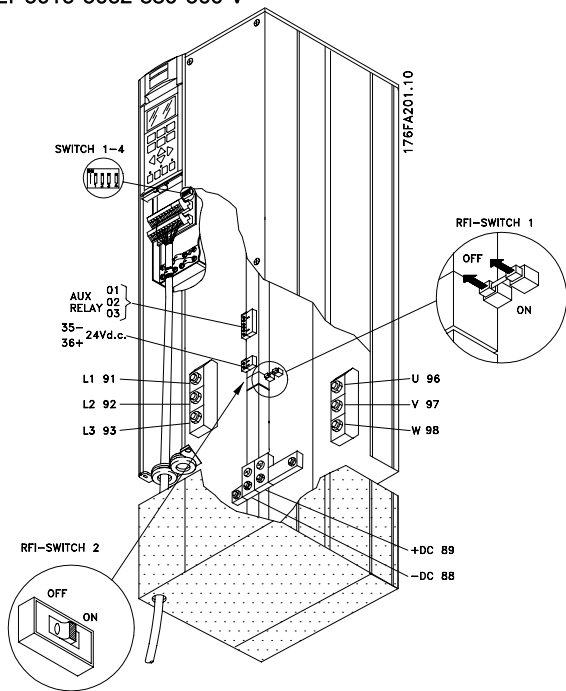

Compact IP 54
VLT 5032-5052 200-240 V

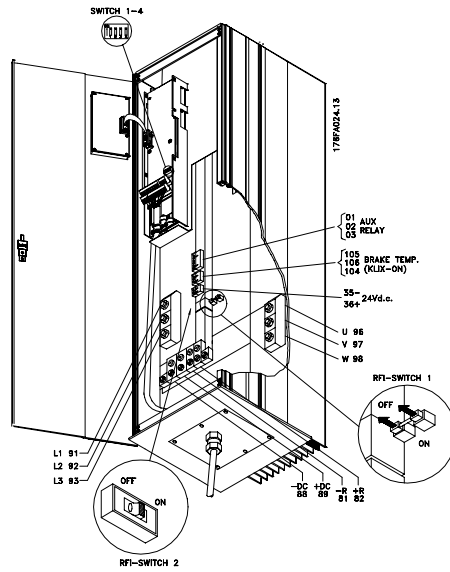

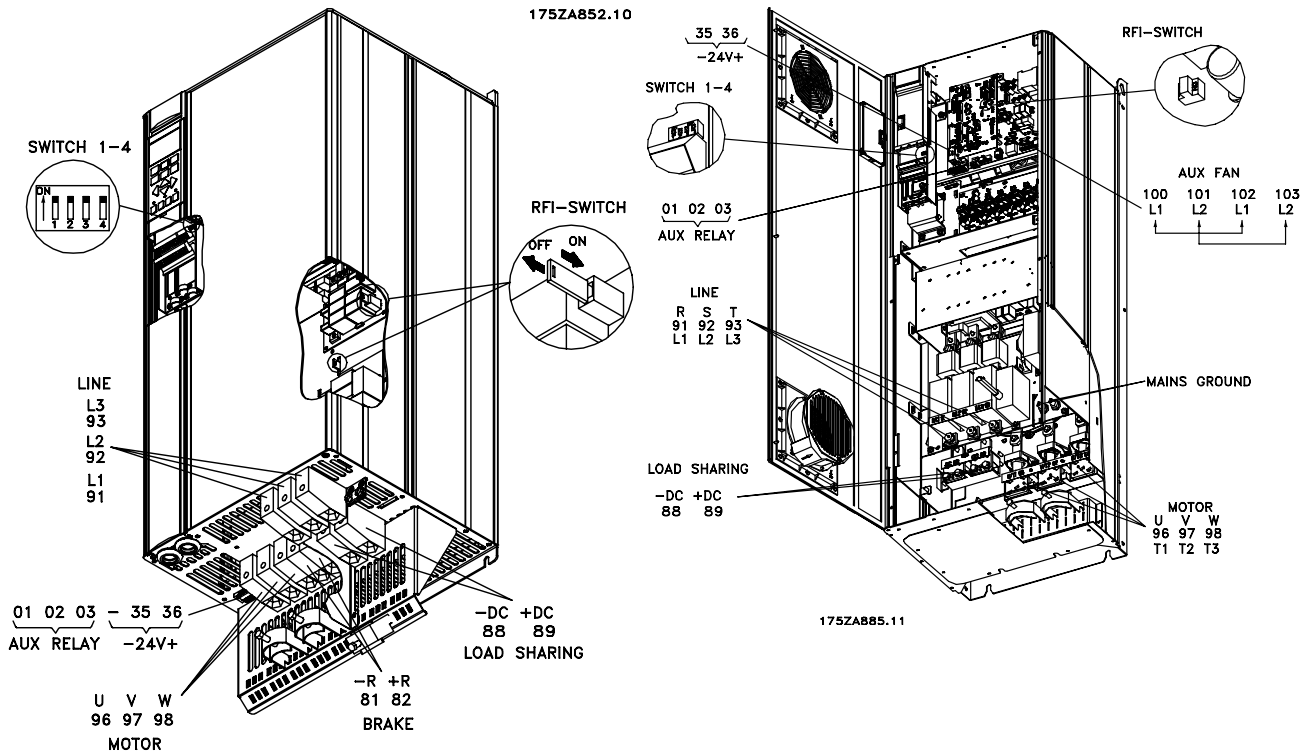

Compact IP 20
VLT 5072-5102 380-500 V

Compact IP 21/IP 54 with disconnect and fuse
VLT 5122-5152 380-500 V, VLT 5042-5152 525-690 V
NOTE: The RFI switch has no function in the 525-690 V drives

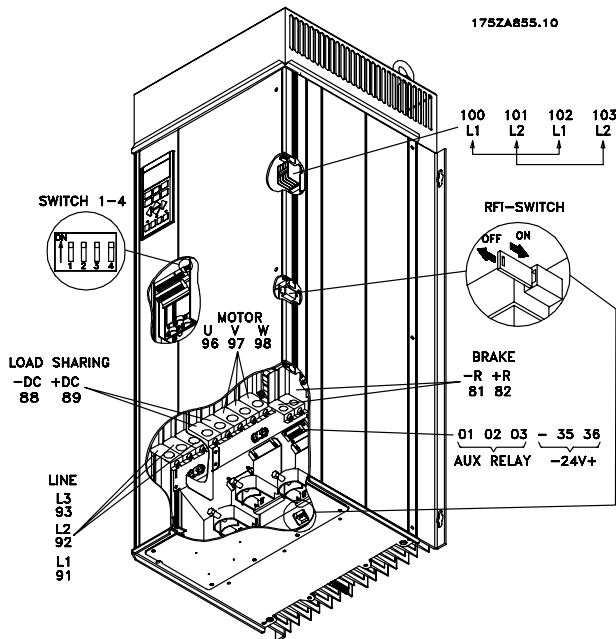

Compact IP 54
VLT 5072-5102 380-500 V

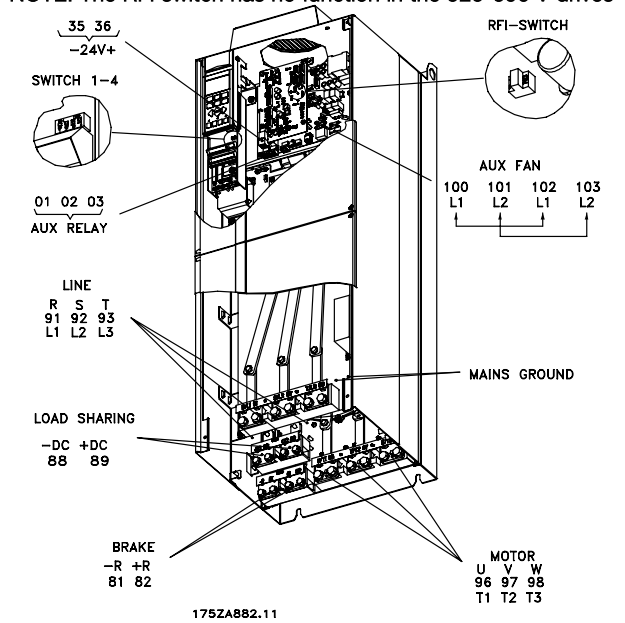

Compact IP 00 without disconnect and fuse
VLT 5122-5152 380-500 V, VLT 5042-5152 525-690 V

Electrical installation

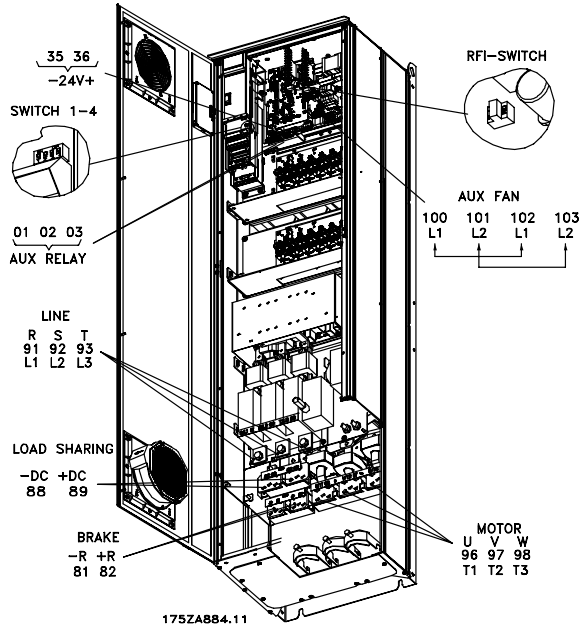

Compact IP 21/IP 54 with disconnect and fuse
VLT 5202-5302 380-500 V, VLT 5202-5352 525-690 V

Note: The RFI switch has no function in the 525-690 V drives

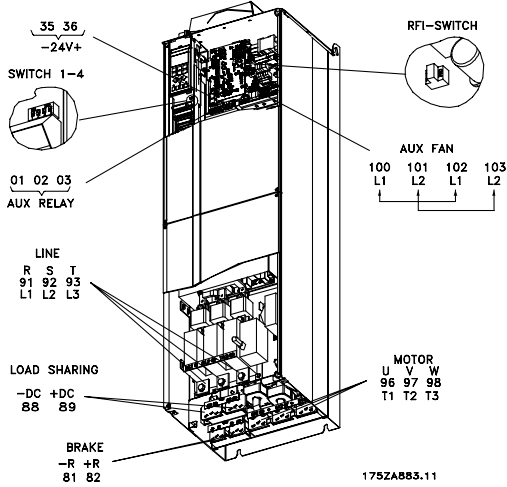

Compact IP 00 with disconnect and fuse
VLT 5202-5302 380-500 V, VLT 5202-5352 525-690 V

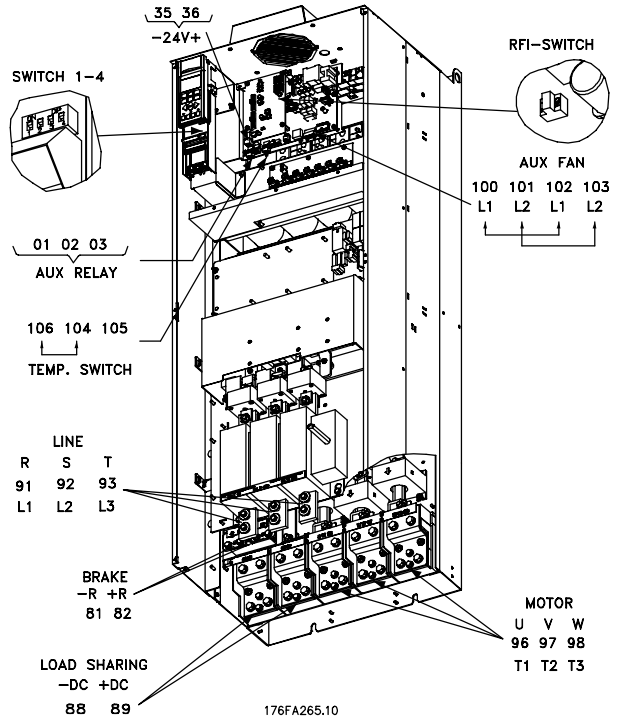

Compact IP 00 with disconnect and fuse
VLT 5352-5552 380-500 V, VLT 5402-5602 525-690 V

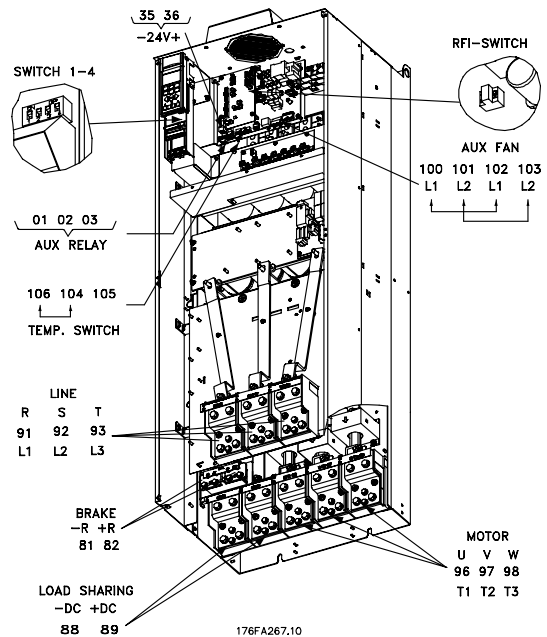

Compact IP 00 without disconnect and fuse
VLT 5352-5552 380-500 V, VLT 5402-5602 525-690 V

Note: The RFI switch has no function in the 525-690 V drives

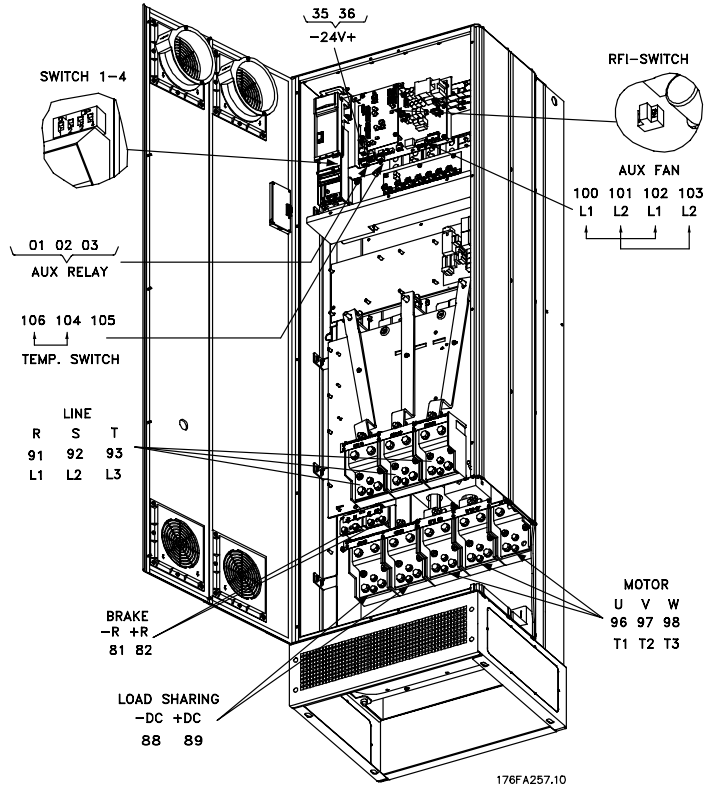

**Compact IP 21/IP 54 without disconnect and fuse
VLT 5352-5552 380-500 V, VLT 5402-5602, 525-690 V**

Note: The RFI switch has no function in the 525-690 V drives.

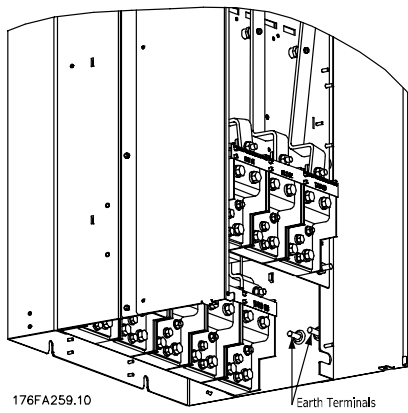

Position of earth terminals, IP 00

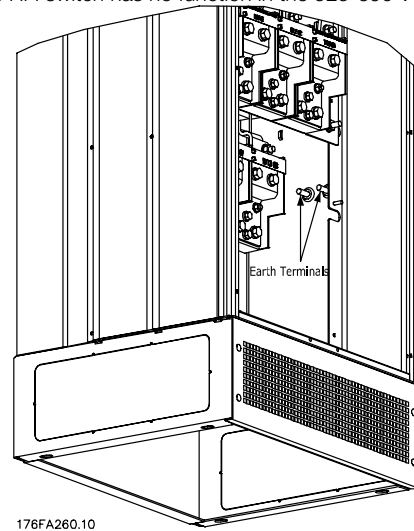

Position of earth terminals, IP 21/ IP 54

Electrical installation

■ Electrical installation, power cables

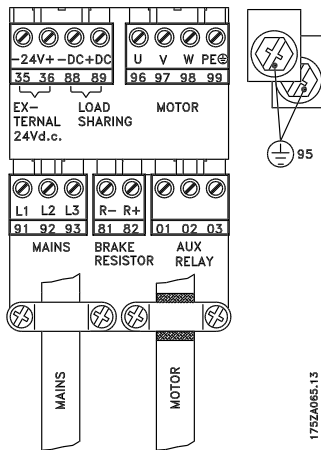

175ZA065.13

Bookstyle

VLT 5001-5006 200-240 V

VLT 5001-5011 380-500 V

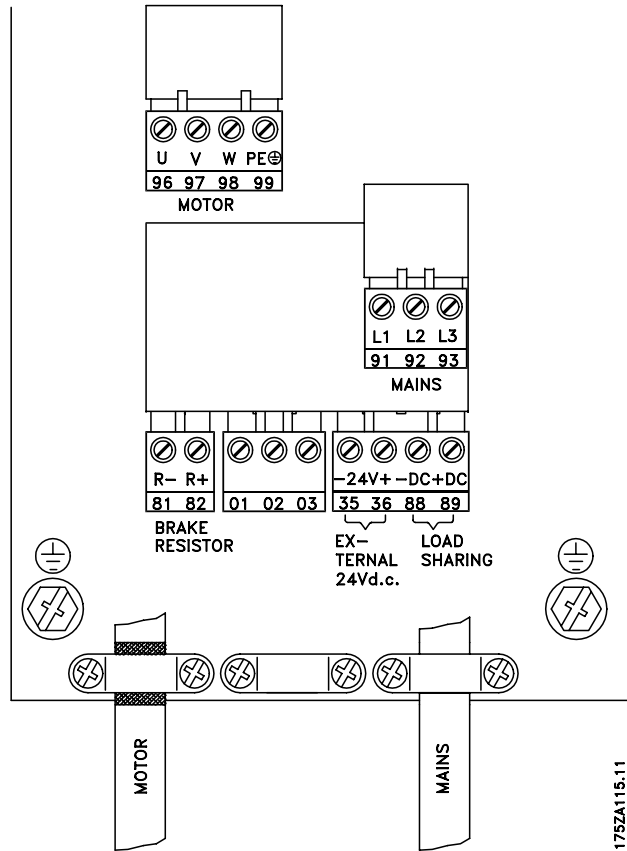

175ZA115.11

Compact IP 54

VLT 5001-5006 200-240 V

VLT 5001-5011 380-500 V

VLT 5001-5011 525-600 V

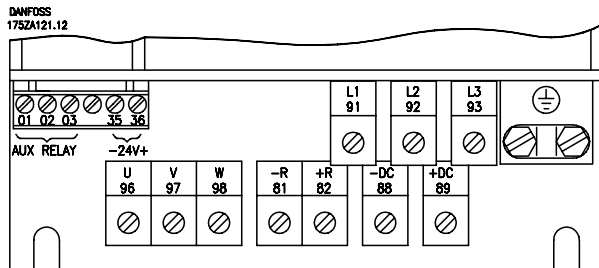

DANFOSS
175ZA121.12

Compact IP 00/NEMA 1

VLT 5008-5027 200-240 V

VLT 5016-5102 380-500 V

VLT 5016-5062 525-600 V

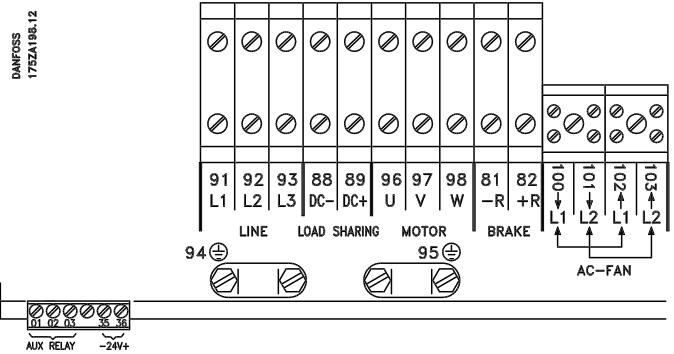

DANFOSS
175ZA196.12

Compact IP 54

VLT 5008-5027 200-240 V

VLT 5016-5062 380-500 V

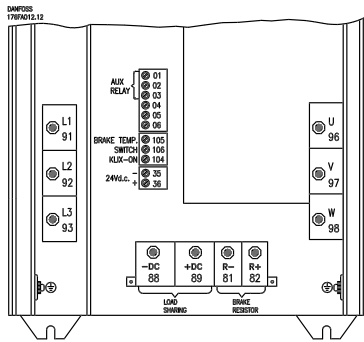

Compact IP 00/NEMA 1 (IP20)
VLT 5032-5052 200-240 V

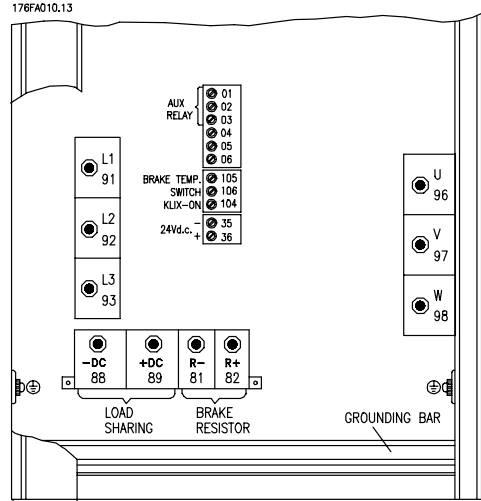

Compact IP 54
VLT 5032-5052 200-240 V

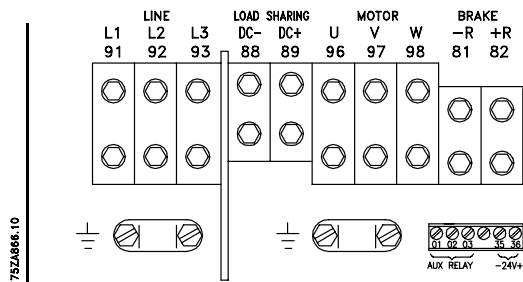

Compact IP 54
VLT 5072-5102 380-500 V

Electrical
installation

■ Electrical installation - control cables

All terminals for the control cables are located under the protective cover of the frequency converter. The protective cover (see drawing) can be removed by means of a pointed object - a screwdriver or similar.

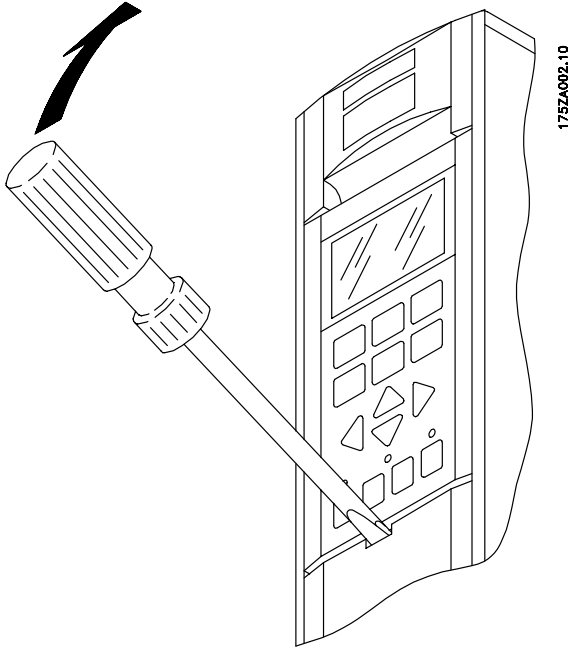

175ZA002.10

Once the protective cover has been removed, the actual EMC-correct installation can start. See drawings in the section, *EMC correct installation*.

Tightening-up torque: 0.5-0.6 Nm

Screw size: M3

See section *earthing of braided screened/armoured control cables*.

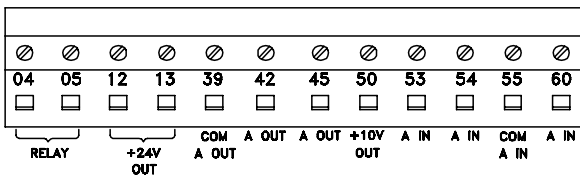
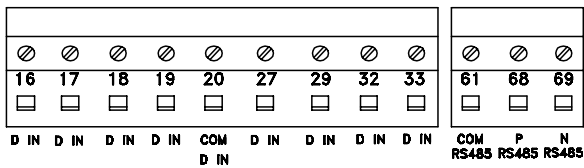

175HA378.10

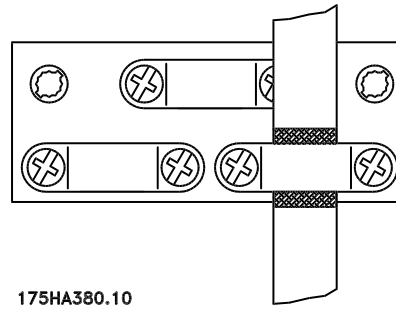

175HA380.10

No.	Function
12, 13	Voltage supply to digital inputs For the 24 V DC to be usable for the digital inputs, switch 4 on the control card must be closed. position "ON".
16-33	Digital inputs/encoder inputs
20	Ground for digital inputs
39	Ground for analogue/digital outputs
42, 45	Analogue/digital outputs for indicating frequency, reference, current and torque
50	Supply voltage to potentiometer and thermistor 10 V DC
53, 54	Analogue reference input, voltage 0 - ±10 V
55	Ground for analogue reference inputs
60	Analogue reference input, current 0/4-20 mA
61	Termination for serial communication. See section <i>Bus connection</i> . This terminal is normally not to be used.
68, 69	RS 485 interface, serial communication. Where the frequency converter is connected to a bus, switches 2 and 3 (switches 1- 4) must be closed on the first and the last frequency converter. On the remaining frequency converters, switches 2 and 3 must be open. The factory setting is closed (position "ON").

■ Electrical installation

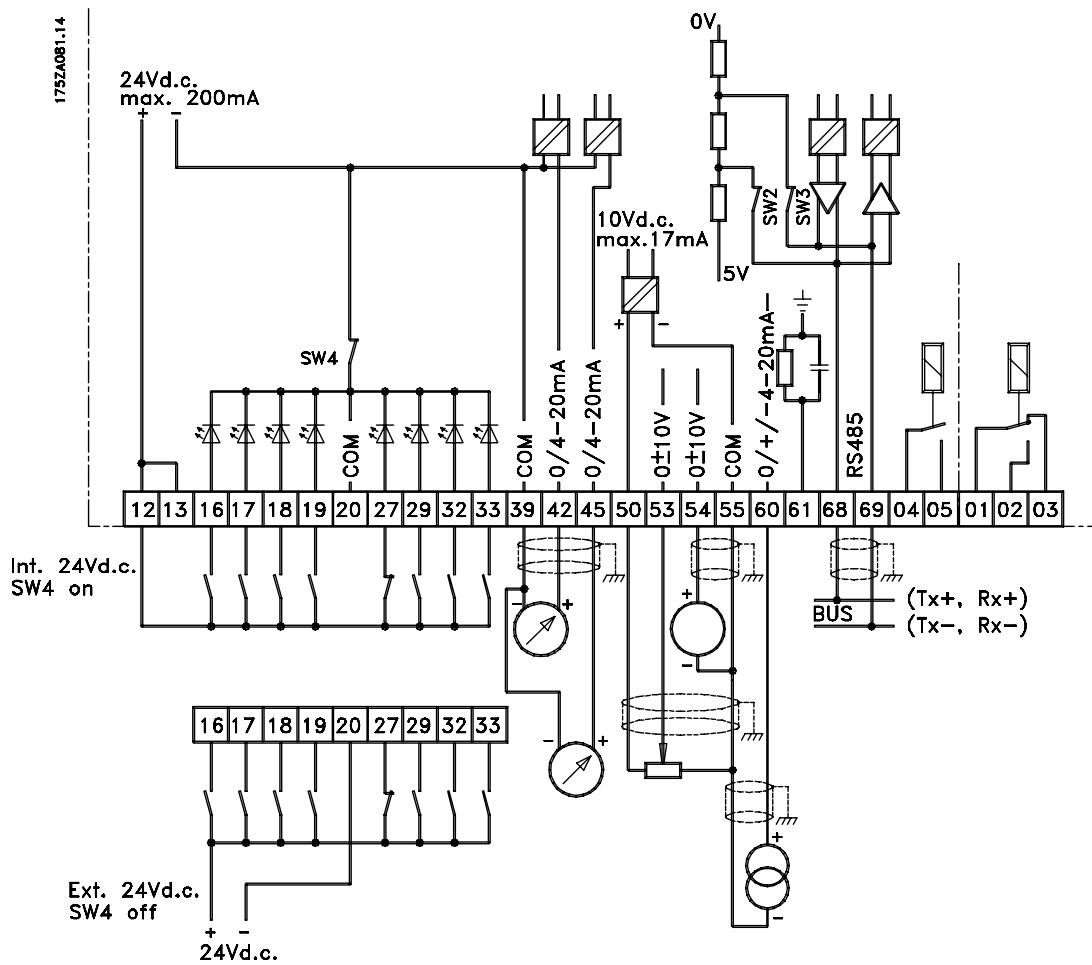

Conversion of analogue inputs

Current input signal to voltage input

0-20 mA	0-10 V	Connect 510 ohms resistor between input terminal 53 and 55 (terminal 54 and 55) and adjust minimum and maximum values in parameters 309 and 310 (parameters 312 and 313).
4-20 mA	2-10 V	

■ **Electrical installation - bus connection**

The serial bus connection in accordance with the RS 485 (2-conductor) norm is connected to terminals 68/69 of the frequency converter (signals P and N). Signal P is the positive potential (TX+,RX+), while signal N is the negative potential (TX-,RX-).

If more than one frequency converter is to be connected to a given master, use parallel connections.

175ZA079.11

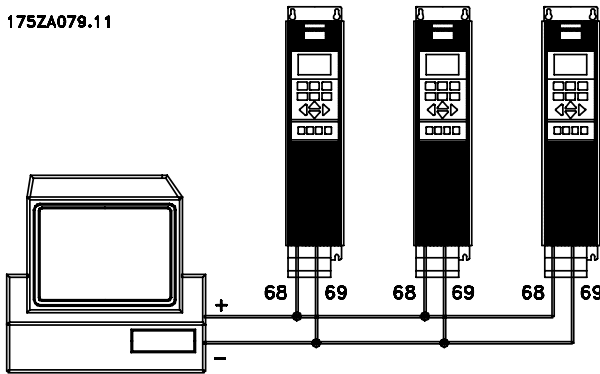

In order to avoid potential equalizing currents in the screen, the cable screen can be earthed via terminal 61, which is connected to the frame via an RC-link.

Bus termination

The bus must be terminated by a resistor network at both ends. For this purpose, set switches 2 and 3 on the control card for "ON".

■ **DIP Switches 1-4**

The dipswitch is located on the control card. It is used for serial communication, terminals 68 and 69. The switching position shown is the factory setting.

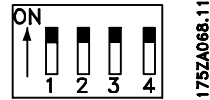

Switch 1 has no function.

Switches 2 and 3 are used for terminating an RS 485 interface, serial communication.

Switch 4 is used for separating the common potential for the internal 24 V DC supply from the common potential of the external 24 V DC supply.



NB!:

Please note that when Switch 4 is in position "OFF", the external 24 V DC supply is galvanically isolated from the frequency converter.

■ Electrical installation - EMC precautions

The following is a guideline to good engineering practice, when installing drives. Following these guidelines is advised, where compliance with EN 61000-6-3, EN 61000-6-4, EN 55011 or EN 61800-3 *First environment* is required. If the installation is in EN 61800-3 *Second environment*, i.e. industrial networks or in an installation that has its own transformer, it is acceptable to deviate from these guidelines. It is however not recommended. See also *CE labelling, Emission and EMC test results* under special conditions in the Design Guide for further details.

Good engineering practice to ensure EMC-correct electrical installation:

- Use only braided screened/armoured motor cables and braided screened/armoured control cables. The screen should provide a minimum coverage of 80%. The screen material must be metal, not limited to but typically copper, aluminium, steel or lead. There are no special requirements for the mains cable.
- Installations using rigid metal conduits are not required to use screened cable, but the motor cable must be installed in conduit separate from the control and mains cables. Full connection of the conduit from the drive to the motor is required. The EMC performance of flexible conduits varies a lot and information from the manufacturer must be obtained.
- Connect the screen/armour/conduit to earth at both ends for motor cables as well as for control cables. In some cases, it is not possible to connect the screen in both ends. In these cases, it is important to connect the screen at the frequency converter. See also *Earthing of braided screened/armoured control cables*.
- Avoid terminating the screen/armour with twisted ends (pigtailed). Such a termination increases the high frequency impedance of the screen, which reduces its effectiveness at high frequencies. Use low impedance cable clamps or EMC cable glands instead.
- It is important to ensure good electrical contact between the mounting plate on which the frequency converter is installed and the metal chassis of the frequency converter. However, this does not apply to IP 54 units as they are designed for wall-mounting and VLT 5122-5552 380-500 V, 5042-5602 525-690 V and VLT 5032-5052 200-240 V in IP20/NEMA 1 enclosure and IP 54/NEMA 12 enclosure.
- Use starwashers and galvanically conductive installation plates to secure good electrical connections for IP00 and IP20 installations.
- Avoid using unscreened/unarmoured motor or control cables inside cabinets housing the drive(s), whenever this can be avoided.
- An uninterrupted high frequency connection between the frequency converter and the motor units is required for IP54 units.

The illustration shows an example of an EMC-correct electrical installation of an IP 20 frequency converter; the frequency converter has been fitted in an installation cabinet with an output contactor and connected to a PLC, which in this example is installed in a separate cabinet. In IP 54 units and VLT 5032-5052, 200-240 V in IP20/IP21/NEMA 1 enclosure screened cables are connected by using EMC conduits to ensure proper EMC performance. See illustration. Other ways of making the installation may have as good an EMC performance, provided the above guidelines to engineering practice are followed.

Please note, that when the installation is not carried through according to the guideline as well as when unscreened cables and control wires are used, some emission requirements are not complied with, although the immunity requirements are fulfilled. See the section *EMC test results* in the Design Guide for further details.

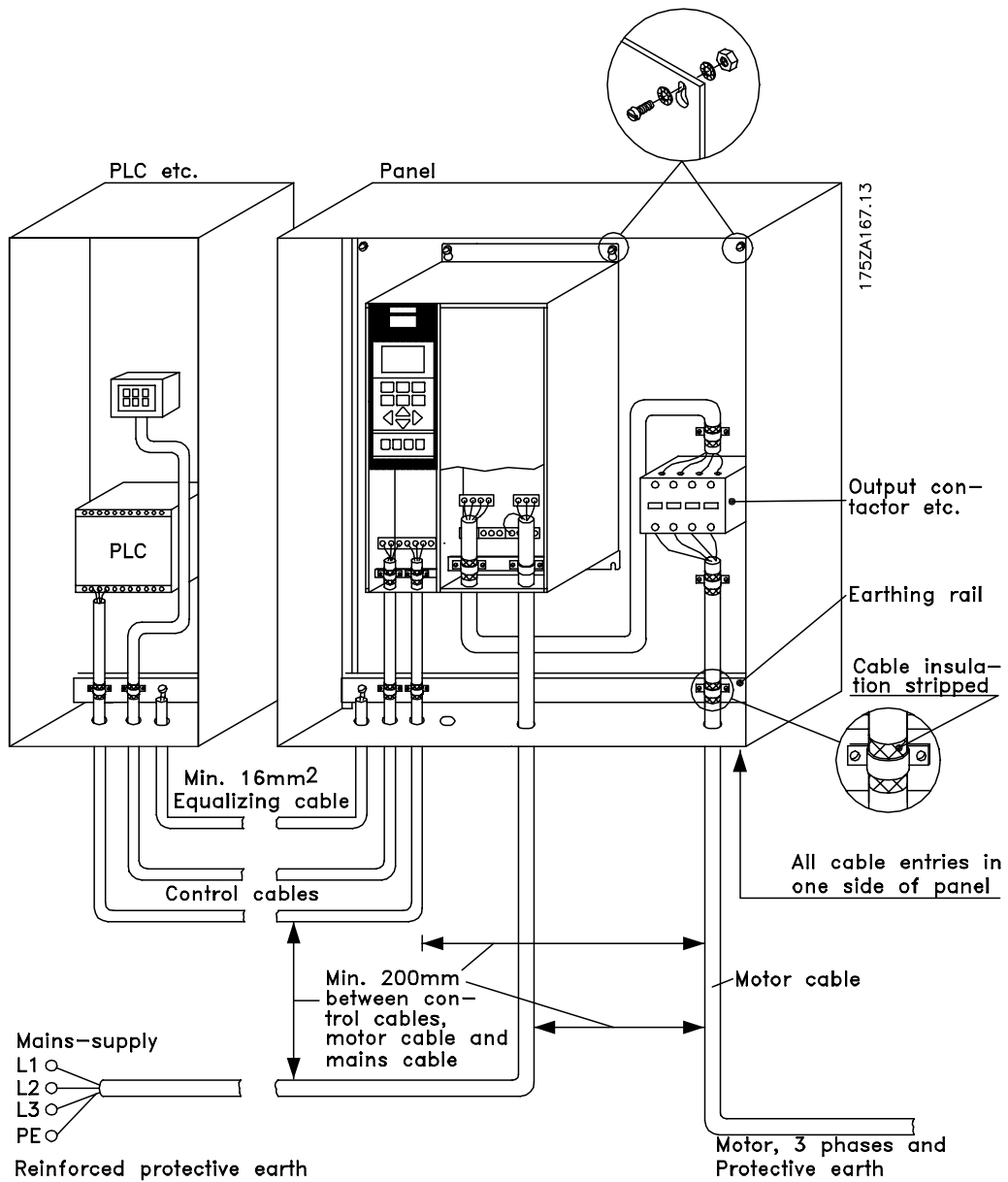

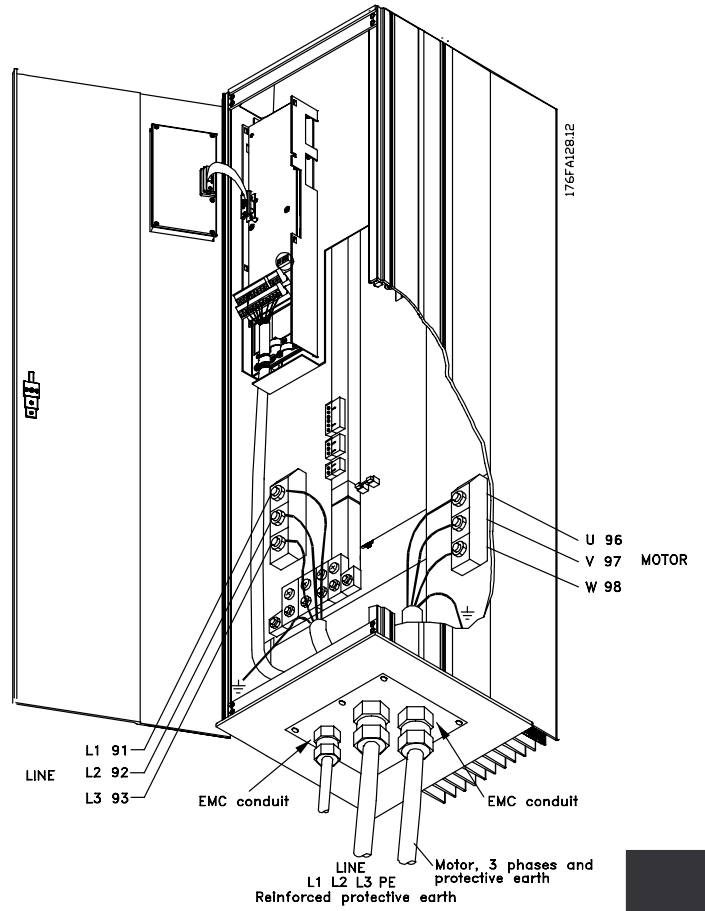
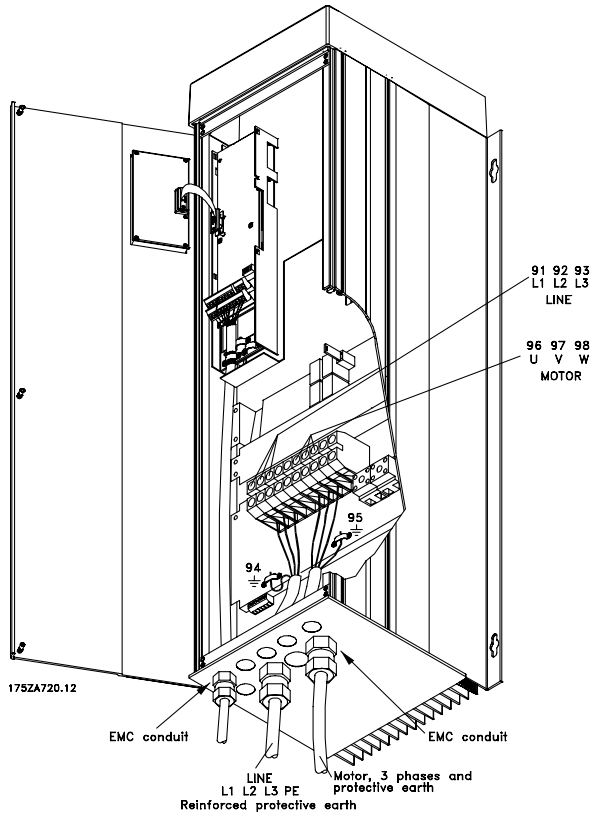

■ Use of emc-correct cables

Braided screened/armoured cables are recommended to optimise EMC immunity of the control cables and the EMC emission from the motor cables.

The ability of a cable to reduce the in- and outgoing radiation of electric noise depends on the transfer impedance (Z_T). The screen of a cable is normally designed to reduce the transfer of electric noise; however, a screen with a lower transfer impedance (Z_T) value is more effective than a screen with a higher transfer impedance (Z_T).

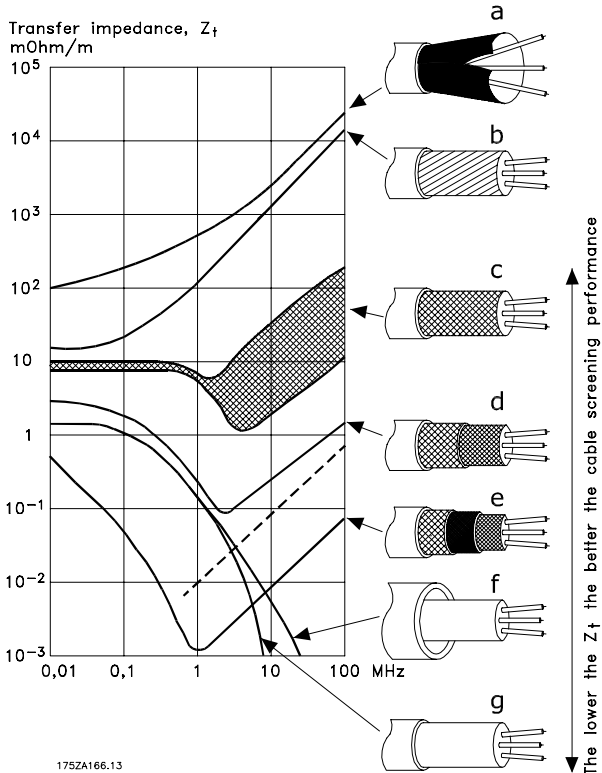

175ZA166.13

Transfer impedance (Z_T) is rarely stated by cable manufacturers, but it is often possible to estimate transfer impedance (Z_T) by assessing the physical design of the cable.

Transfer impedance (Z_T) can be assessed on the basis of the following factors:

- The conductivity of the screen material.
- The contact resistance between the individual screen conductors.
- The screen coverage, i.e. the physical area of the cable covered by the screen - often stated as a percentage value.
- Screen type, i.e. braided or twisted pattern.

Aluminium-clad with copper wire.

Twisted copper wire or armoured steel wire cable.

Single-layer braided copper wire with varying percentage screen coverage.

This is the typical Danfoss reference cable.

Double-layer braided copper wire.

Twin layer of braided copper wire with a magnetic, screened/armoured intermediate layer.

Cable that runs in copper tube or steel tube.

Lead cable with 1.1 mm wall thickness.

Electrical installation - earthing of control cables

Generally speaking, control cables must be braided screened/armoured and the screen must be connected by means of a cable clamp at both ends to the metal cabinet of the unit.

The drawing below indicates how correct earthing is carried out and what to be done if in doubt.

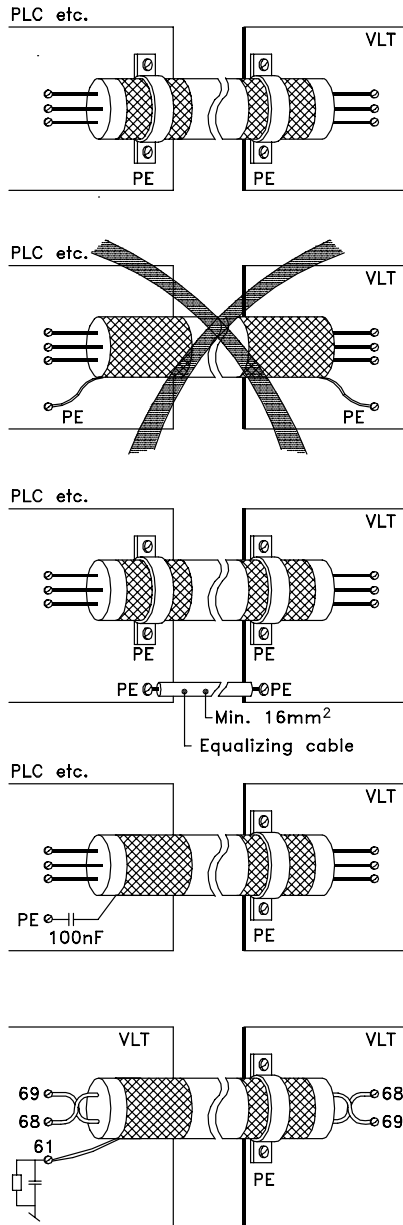

175ZA165.11

Correct earthing

Control cables and cables for serial communication must be fitted with cable clamps at both ends to ensure the best possible electrical contact

Wrong earthing

Do not use twisted cable ends (pigtails), since these increase the screen impedance at high frequencies.

Protection with respect to earth potential between PLC and VLT

If the earth potential between the frequency converter and the PLC (etc.) is different, electric noise may occur that will disturb the whole system. This problem can be solved by fitting an equalising cable, to be placed next to the control cable. Minimum cable cross-section: 16 mm².

For 50/60 Hz earth loops

If very long control cables are used, 50/60 Hz earth loops may occur. This problem can be solved by connecting one end of the screen to earth via a 100nF capacitor (keeping leads short).

Cables for serial communication

Low-frequency noise currents between two frequency converters can be eliminated by connecting one end of the screen to terminal 61. This terminal is connected to earth via an internal RC link. It is recommended to use twisted-pair cables to reduce the differential mode interference between the conductors.

Electrical installation

■ RFI switch

Mains supply isolated from earth:

If the frequency converter is supplied from an isolated mains source (IT mains) or TT/TN-S mains with grounded leg, the RFI switch is recommended to be turned off (OFF)¹⁾. For further reference, see IEC 364-3. In case optimum EMC performance is needed, parallel motors are connected or the motor cable length is above 25 m, it is recommended to set the switch in ON position.

In OFF position, the internal RFI capacities (filter capacitors) between the chassis and the intermediate circuit are cut off to avoid damage to the intermediate circuit and to reduce the earth capacity currents (according to IEC 61800-3).

Please also refer to the application note *VLT on IT mains*, MN.90.CX.02. It is important to use isolation monitors that are capable for use together with power electronics (IEC 61557-8).



NB!:

The RFI switch is not to be operated with mains connected to the unit. Check that the mains supply has been disconnected before operating the RFI switch.



NB!:

Open RFI switch is only allowed at factory set switching frequencies.



NB!:

The RFI switch connects the capacitors galvanically to earth.

The red switches are operated by means of e.g. a screwdriver. They are set in the OFF position when they are pulled out and in ON position when they are pushed in. Factory setting is ON.

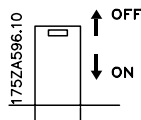

Mains supply connected to earth:

The RFI switch must be in ON position in order for the frequency converter to comply with the EMC standard.

1) Not possible with 5042-5602, 525-690 V units.

Position of RFI switches

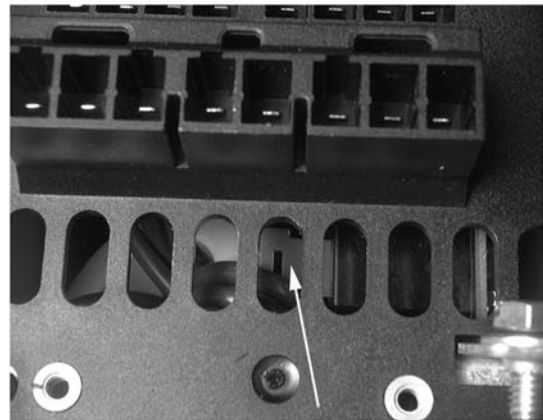

175ZA649.10

Bookstyle IP 20

VLT 5001 - 5006 200 - 240 V

VLT 5001 - 5011 380 - 500 V

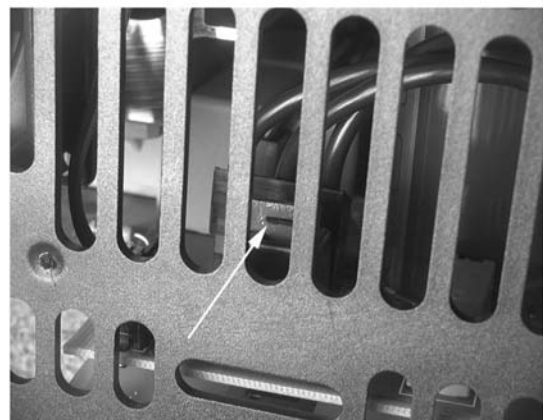

175ZA650.10

Compact IP 20/NEMA 1

VLT 5001 - 5006 200 - 240 V

VLT 5001 - 5011 380 - 500 V

VLT 5001 - 5011 525 - 600 V

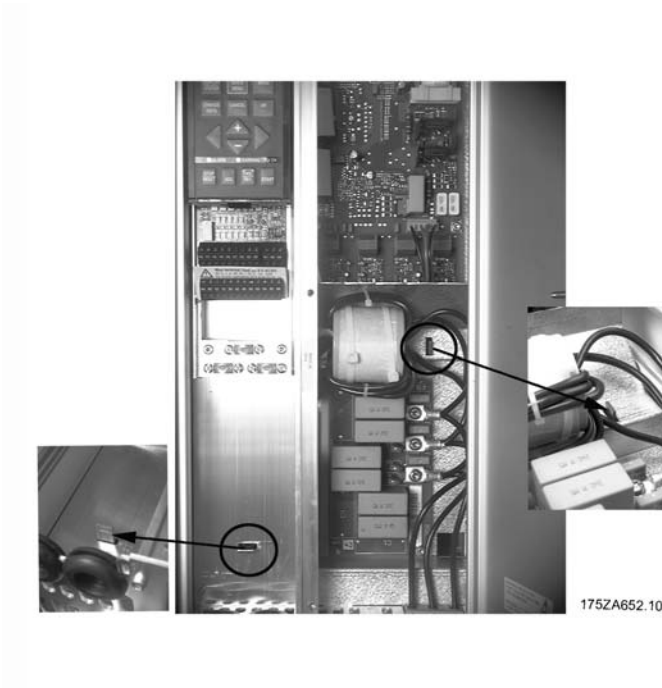

Compact IP 20/NEMA 1
VLT 5008 200 - 240 V
VLT 5016 - 5022 380 - 500 V
VLT 5016 - 5022 525 - 600 V

Compact IP 20/NEMA 1
VLT 5022 - 5027 200 - 240 V
VLT 5042 - 5102 380 - 500 V
VLT 5042 - 5062 525 - 600 V

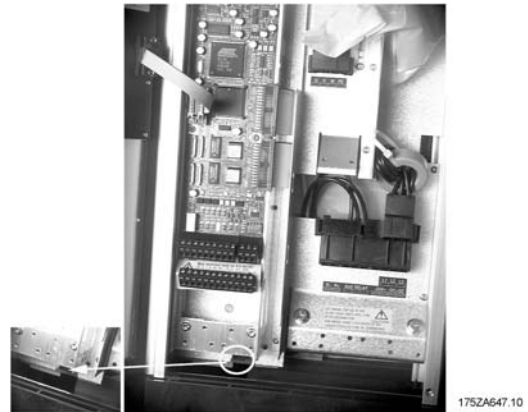

Compact IP 20/NEMA 1
VLT 5011 - 5016 200 - 240 V
VLT 5027 - 5032 380 - 500 V
VLT 5027 - 5032 525 - 600 V

Compact IP 54
VLT 5001 - 5006 200 - 240 V
VLT 5001 - 5011 380 - 500 V

Electrical
 installation



175ZA651.10

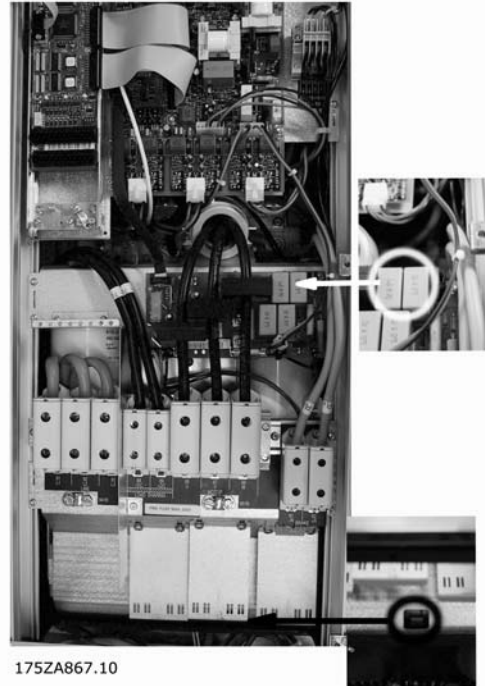

175ZA867.10

Compact IP 54
VLT 5008 - 5011 200 - 240 V
VLT 5016 - 5027 380 - 500 V

Compact IP 54
VLT 5072 - 5102 380 - 500 V



175ZA654.10

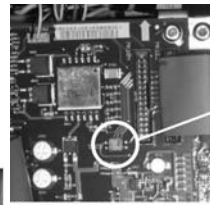

175ZT983.10

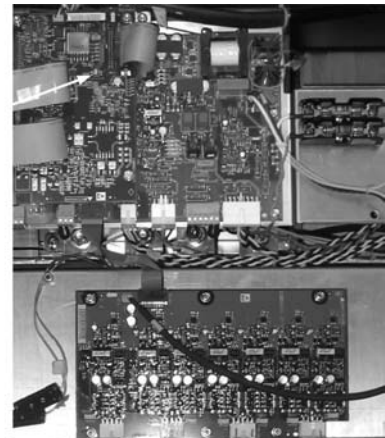

Compact IP 54
VLT 5016 - 5027 200 - 240 V
VLT 5032 - 5062 380 - 500 V

All enclosure types
VLT 5122-5552 380 - 500 V

Serial communication

Protocols

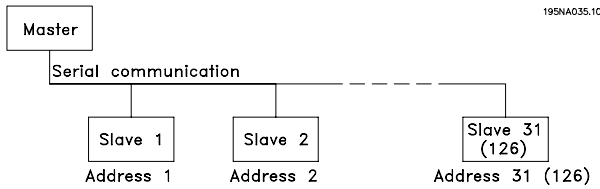

Telegram Traffic

Control and response telegrams

Telegram traffic in a master-slave system is controlled by the master. A maximum of 31 slaves can be connected to a master, unless repeaters are used. If repeaters are used, a maximum of 126 slaves can be connected to a master.

The master constantly sends telegrams addressed to the slaves and waits for response telegrams from them. The slave's response time is a maximum of 50 ms.

Only a slave that has received an error-free telegram, addressed to that slave can send a response telegram.

Broadcast

A master can send the same telegram simultaneously to all slaves connected to the bus. During this broadcast communication the slave does not send any response telegrams back to the master as to whether the telegram has been correctly received. Broadcast communication is set up in address format (ADR), see *Telegram structure*.

Content of a character (byte)

Each character transferred begins with a start bit. Then 8 data bits are transferred, corresponding to a byte. Each character is secured via a parity bit, which is set at "1" when it reaches parity (i.e. when there is an equal number of 1's in the 8 data bits and the parity bit in total). A character is completed by a stop bit, thus consisting of 11 bits in all.

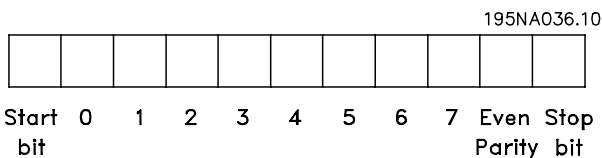

address of the frequency converter (ADR). Then follows a number of data bytes (variable, depending on the type of telegram). The telegram is completed by a data control byte (BCC).

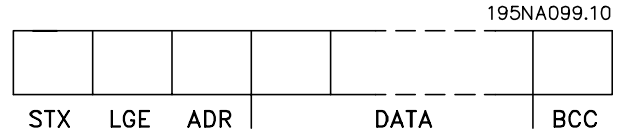

Telegram timing

The communication speed between a master and a slave depends on the baud rate. The frequency converter's baud rate must be the same as the master's baud rate and be selected in parameter 501 *Baudrate*. After a response telegram from the slave, there must be a pause of at least 2 characters (22 bits) before the master can send a new telegram. At a baud rate of 9600 baud there must be a pause of at least 2.3 ms. When the master has completed the telegram, the slave's response time back to the master will be a maximum of 20 ms, and there will be a pause of at least 2 characters.

195NA038.10

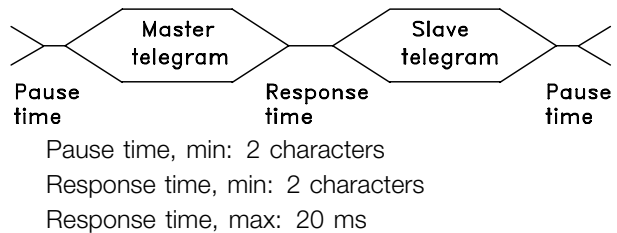

The time between the individual characters in a telegram may not exceed 2 characters and the telegram must be completed within 1.5 x nominal telegram time. At a baud rate of 9600 baud and a telegram length of 16 bytes the telegram will be completed after 27.5 msec.

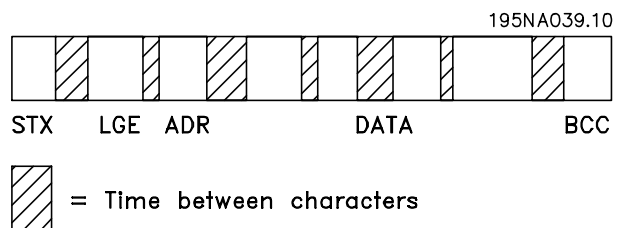

Telegram Structure

Each telegram begins with a start character (STX) = 02 Hex, followed by a byte that denotes the length of the telegram (LGE) and a byte that denotes the

VLT 5000 Design Guide

Telegram length (LGE)

The telegram length is the number of data bytes plus the address byte ADR plus the data control byte BCC.

The length of telegrams with 4 data bytes is:

$$LGE = 4 + 1 + 1 = 6 \text{ bytes}$$

The length of telegrams with 12 data bytes is:

$$LGE = 12 + 1 + 1 = 14 \text{ bytes}$$

The length of telegrams containing texts is 10+n bytes.

10 represents the fixed characters, while the 'n' is variable (depending on the length of the text).

Frequency converter address (ADR)

Two different address formats are used, with the frequency converter's address range being either 1-31 or 1-126.

1. Address format 1-31

The byte for address range 1-31 has the following profile:

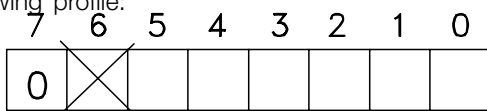

195NA040.10

- Bit 7 = 0 (address format 1-31 active)
- Bit 6 is not used
- Bit 5 = 1: Broadcast, address bits (0-4) are not used
- Bit 5 = 0: No Broadcast
- Bit 0-4 = Frequency converter address 1-31

2. Address format 1-126

The byte for address range 1 - 126 has the following profile:

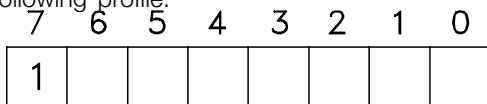

195NA041.10

- Bit 7 = 1 (address format 1-126 active)
- Bit 0-6 = Frequency converter address 1-126
- Bit 0-6 = 0 Broadcast

The slave sends the address byte back unchanged in the response telegram to the master.

Example:

writing to frequency converter address 22 (16H) with address format 1-31:

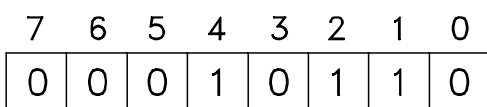

195NA042.10

Data control byte (BCC)

The data control byte is explained in this example: Before the first byte in the telegram is received, the Calculated CheckSum (BCS) is 0.

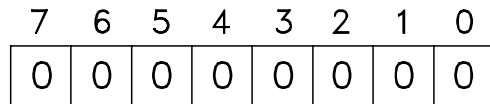

195NA043.10

When the first byte (02H) has been received:

BCS = BCC EXOR "first byte"

(EXOR = exclusive-or)

BCS = 0 0 0 0 0 0 0 0 (00 H)

EXOR

1. byte = 0 0 0 0 0 1 0 (02H)

BCC = 0 0 0 0 0 1 0 (02H)

Each subsequent byte gates with BCS EXOR and produces a new BCC, e.g.:

BCS = 0 0 0 0 0 1 0 (02H)

EXOR

2nd byte = 1 1 0 1 0 1 1 0 (D6H)

BCC = 1 1 0 1 0 1 0 0 (D4H)

■ Data Character (byte)

The structure of data blocks depends on the type of telegram. There are three types of telegram, and the type of telegram applies for both control telegrams (master slave) and response telegrams (slave master). The three types of telegram are:

- Parameter block, used to transfer parameters between master and slave. The data block is made up of 12 bytes (6 words) and also contains the process block.

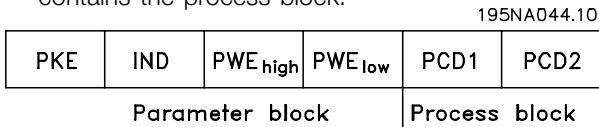

- The process block is made up of a data block of four bytes (2 words) and contains:
 - Control word and reference value
 - Status word and present output frequency (from slave to master)

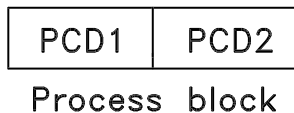

- Text block, which is used to read or write texts via the data block.

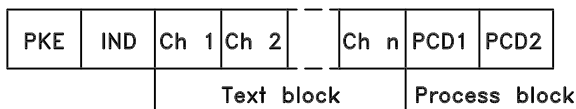

Parameter commands and responses (AK)

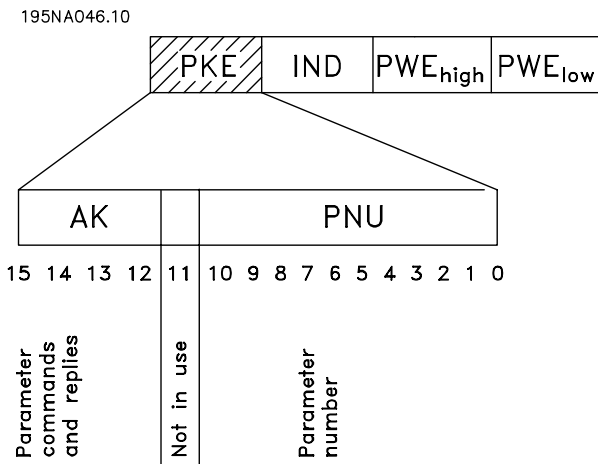

Bits no. 12-15 are used to transfer parameter commands from master to slave and the slave's processed responses back to the master.

Parameter commands master slave				
Bit no.				
15	14	13	12	Parameter command
0	0	0	0	No command
0	0	0	1	Read parameter value
0	0	1	0	Write parameter value in RAM (word)
0	0	1	1	Write parameter value in RAM (double word)
1	1	0	1	Write parameter value in RAM and EEPROM (double word)
1	1	1	0	Write parameter value in RAM and EEPROM (word)
1	1	1	1	Read/write text

Response slave master				
Bit no.				
15	14	13	12	Response
0	0	0	0	No response
0	0	0	1	Parameter value transferred (word)
0	0	1	0	Parameter value transferred (double word)
0	1	1	1	Command cannot be performed
1	1	1	1	Text transferred

If the command cannot be performed the slave sends this response: 0111 *Command cannot be performed* and gives the following fault report in the parameter value (PWE):

Response (0111)	Fault report
0	The parameter number used does not exist
1	There is no write access to the defined parameter
2	Data value exceeds the parameter's limits
3	The sub index used does not exist
4	The parameter is not the array type
5	The data type does not match the defined parameter
17	Data change in the defined parameter is not possible in the frequency converter's present mode. Certain parameters can only be changed when the motor is turned off
130	There is no bus access to the defined parameter
131	Data change is not possible because factory Setup is selected

Parameter number (PNU)

Bits no. 0-10 are used to transfer parameter numbers. The relevant parameter's function is defined in the parameter description in the section entitled *Programming*.

Index



Index is used together with the parameter number to read/write-access parameters that have an index, e.g. parameter 615 *Error code*. The index is made up of 2 bytes, one lowbyte and one highbyte, but only the lowbyte is used as an index.

Example - Index:

The first error code (index [1]) in parameter 615 *Error code* must be read.

PKE = 1267 Hex (read parameter 615 *Error code*.)

IND = 0001 Hex - Index no. 1.

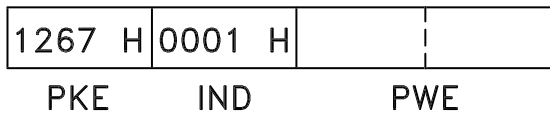

The frequency converter will respond in the parameter value block (PWE) with a fault code value from 1 - 99. See *Summary of Warnings and Alarms* to identify the fault code.

Parameter value (PWE)

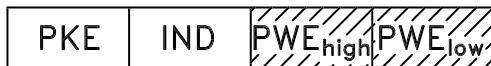

The parameter value block consists of 2 words (4 bytes), and the value depends on the defined command (AK). If the master prompts for a parameter value, the PWE block does not contain a value. If you wish the master to change a parameter value (write), the new value is written in the PWE block and sent to the slave. If the slave responds to a parameter request (read command), the present parameter value in the PWE block is transferred and returned to the master. If a parameter contains not a numerical value, but several data options, e.g. parameter 001 *Language* where [0] corresponds to *English*,

and [3] corresponds to *Danish*, the data value is selected by entering the value in the PWE block. See *Example - Selecting a data value*.

Via serial communication it is only possible to read parameters that have data type 9 (text string). Parameter 621 - 635 *Nameplate data* is data type 9. For example, in parameter 621 *Unit type* it is possible to read the unit size and mains voltage range.

When a text string is transferred (read) the length of the telegram is variable, as the texts are of different lengths. The telegram length is defined in the telegram's second byte, known as LGE.

To be able to read a text via the PWE block the parameter command (AK) must be set to 'F' Hex.

The index character is used to indicate whether it is a read or write command.

In a read command the index must have the following format:

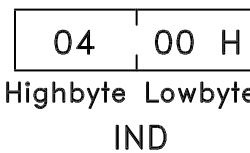

Some frequency converters have parameters to which a text may be written. To be able to write a text via the PWE block the parameter command (AK) must be set to 'F' Hex.

For a write command the text must have the following format:

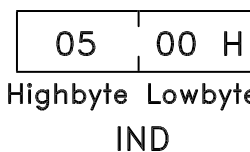

Data types supported by frequency converter:

Data types	Description
3	Integer 16
4	Integer 32
5	Unsigned 8
6	Unsigned 16
7	Unsigned 32
9	Text string
10	Byte string
13	Time difference
33	Reserved
35	Bit sequence

Unsigned means that there is no operational sign in the telegram.

Example - Write a parameter value:

Parameter 202 *Output frequency high limit, f_{MAX}* to be changed to 100 Hz. The value must be recalled after a mains failure, so it is written in EEPROM.

PKE = E0CA Hex - Write for parameter 202

Output frequency high limit, f_{MAX}

IND = 0000 Hex

PWE_{HIGH} = 0000 Hex

PWE_{LOW} = 03E8 Hex - Data value 1000, corresponding to 100 Hz, see conversion.

E0CA H	0000 H	0000 H	03E8 H
PKE	IND	PWE _{high}	PWE _{low}

The response from the slave to the master will be:

10CA H	0000 H	0000 H	03E8 H
PKE	IND	PWE _{high}	PWE _{low}

Example - Selection of a data value:

You wish to select kg/hour [20] in parameter 416 *Process units*. The value must be recalled after a mains failure, so it is written in EEPROM.

PKE = E19F Hex - Write for parameter

416 *Process units*

IND = 0000 Hex

PWE_{HIGH} = 0000 Hex

PWE_{LOW} = 0014 Hex - Select data option kg/hour [20]

E1A0 H	0000 H	0000 H	0014 H
PKE	IND	PWE _{high}	PWE _{low}

The response from the slave to the master will be:

11A0 H	0000 H	0000 H	0014 H
PKE	IND	PWE _{high}	PWE _{low}

Example - Reading a parameter value:

The value in parameter 207 *Ramp up time 1* is required.

The master sends the following request:

PKE = 10CF Hex - read parameter 207

Ramp up time 1

IND = 0000 Hex

PWE_{HIGH} = 0000 Hex

PWE_{LOW} = 0000 Hex

10CF H	0000 H	0000 H	0000 H
PKE	IND	PWE _{high}	PWE _{low}

If the value in parameter 207 *Ramp-up time 1* is 10 sec., the response from the slave to the master will be:

10CF H	0000 H	0000 H	000A H
PKE	IND	PWE _{high}	PWE _{low}

Conversion:

Under the section entitled *Factory Settings* the various attributes of each parameter are displayed.

As a parameter value can only be transferred as a whole number, a conversion factor must be used to transfer decimals.

Example:

Parameter 201 *Output frequency, low limit f_{MIN}* has a conversion factor of 0.1. If you wish to preset the minimum frequency to 10 Hz, the value 100 must be transferred, as a conversion factor of 0.1 means that the value transferred is multiplied by 0.1. The value 100 will thus be perceived as 10.0.

Conversion table

Conversion index	Conversion factor
74	0.1
2	100
1	10
0	1
-1	0.1
-2	0.01
-3	0.001
-4	0.0001
-5	0.00001

■ Process Words

The block of process words is divided into two blocks of 16 bits, which always occur in the defined sequence.

195NA066.10

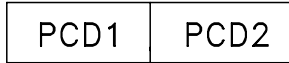

	PCD 1	PCD 2
Control telegram (master slave)	Control word	Reference- value
Control telegram (slave master)	Status word	Present outp. frequency

■ Control Word According to FC Profile

To select *FC protocol* in the control word, parameter 512 *Telegram Profile* must be set to *FC protocol* [1].

The control word is used to send commands from a master (e.g. a PC) to a slave (frequency converter).

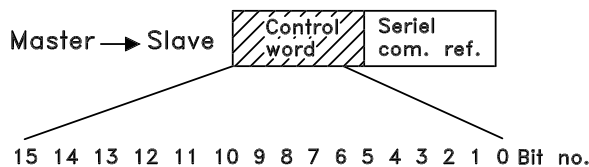

Bit	Bit = 0	Bit = 1
00	Preset reference choice lsb	
01	Preset reference choice msb	
02	DC brake	Ramp
03	Coasting	Enable
04	Quick stop	Ramp
05	Freeze output	Ramp enable
06	Ramp stop	Start
07	No function	Reset
08	No function	Jog
09	Ramp 1	Ramp 2
10	Data not valid	Valid
11	No function	Relay 01 activated
12	No function	Relay 04 activated
13	Choice of Setup (lsb)	
14	Choice of Setup (msb)	
15	No function	Reversing

Bit 00/01:

Bit 00/01 is used to select between the two pre-programmed references (parameters 215-218 *Preset reference*) according to the following table:

Preset ref.	Parameter	Bit 01	Bit 00
1	215	0	0
2	216	0	1
3	217	1	0
4	218	1	1



NB!:

In parameter 508 *Selection of preset reference* a selection is made to define how Bit 00/01 gates with the corresponding function on the digital inputs.

Bit 02, DC brake:

Bit 02 = '0' leads to DC braking and stop. Braking current and duration are set in parameters 125 and 126. Bit 02 = '1' leads to ramping.

Bit 03, Coasting stop:

Bit 03 = '0' causes the frequency converter to immediately "let go" of the motor (the output transistors are "shut off"), so that it coasts to a standstill.

Bit 03 = '1' causes the frequency converter to be able start the motor if the other starting conditions have been fulfilled. Note: In parameter 502 *Coasting stop* a selection is made to define how Bit 03 gates with the corresponding function on a digital input.

Bit 04, Quick stop:

Bit 04 = '0' causes a stop, in which the motor's speed is ramped down to stop via parameter 212 *Quick stop ramp-down time*.

Bit 05, Freeze output frequency:

Bit 05 = '0' causes the present output frequency (in Hz) to freeze. The frozen output frequency can now only be changed by means of the digital inputs programmed to *Speed up* and *Speed down*.



NB!:

If *Freeze output* is active, the frequency converter cannot be stopped via Bit 06 *Start* or via a digital input. The frequency converter can only be stopped by the following:

- Bit 03 Coasting stop
- Bit 02 DC braking
- Digital input programmed to *DC braking*, *Coasting stop* or *Reset and coasting stop*.

Bit 06, Ramp stop/start:

Bit 06 = '0' causes a stop, in which the motor's speed is ramped down to stop via the selected *ramp down* parameter.

Bit 06 = '1' causes the frequency converter to be able to start the motor, if the other starting conditions have been fulfilled. Note: In parameter 505 *Start* a selection is made to define how Bit 06 Ramp stop/start gates with the corresponding function on a digital input.

Bit 07, Reset:

Bit 07 = '0' does not cause a reset.

Bit 07 = '1' causes the reset of a trip. Reset is activated on the signal's leading edge, i.e. when changing from logic '0' to logic '1'.

causes reversing when either *Ser. communication*, *Logic or* or *Logic and* is selected.

Bit 08, Jog:

Bit 08 = '1' causes the output frequency to be determined by parameter 213 *Jog frequency*.

Bit 09, Selection of ramp 1/2:

Bit 09 = "0" means that ramp 1 is active (parameters 207/208). Bit 09 = "1" means that ramp 2 (parameters 209/210) is active.

Bit 10, Data not valid/Data valid:

Is used to tell the frequency converter whether the control word is to be used or ignored. Bit 10 = '0' causes the control word to be ignored, Bit 10 = '1' causes the control word to be used. This function is relevant, because the control word is always contained in the telegram, regardless of which type of telegram is used, i.e. it is possible to turn off the control word if you do not wish to use it in connection with updating or reading parameters.

Bit 11, Relay 01:

Bit 11 = "0" Relay not activated.

Bit 11 = "1" Relay 01 activated, provided *Control word bit* has been chosen in parameter 323.

Bit 12, Relay 04:

Bit 12 = "0" Relay 04 has not been activated.

Bit 12 = "1" Relay 04 has been activated, provided *Control word bit* has been chosen in parameter 326.

Bit 13/14, Selection of Setup:

Bits 13 and 14 are used to choose from the four menu Setups according to the following table:

Setup	Bit 14	Bit 13
1	0	0
2	0	1
3	1	0
4	1	1

The function is only possible when *Multi-Setups* is selected in parameter 004 *Active Setup* .

Note: In parameter 507 *Selection of Setup* a selection is made to define how Bit 13/14 gates with the corresponding function on the digital inputs.

Bit 15 Reversing:

Bit 15 = '0' causes no reversing.

Bit 15 = '1' causes reversing.

Note: In the factory setting reversing is set to *digital* in parameter 506 *Reversing*. Bit 15 only

■ Status Word according to FC Profile

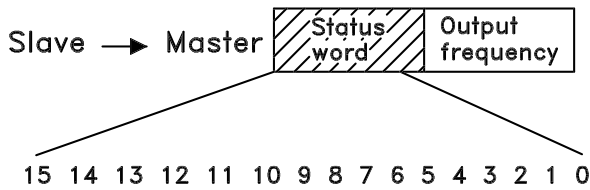

The status word is used to inform the master (e.g. a PC) of the slave's (frequency converter) mode. Slave Master.

Bit	Bit = 0	Bit =1
00	Control not ready	Ready
01	VLT not ready	Ready
02	Coasting	Enable
03	No fault	Trip
04	Reserved	
05	Reserved	
06	Reserved	
07	No warning	Warning
08	Speed ≠ ref.	Speed = ref.
09	Local control	Bus control
10	Out of range	Frequency OK
11	Not running	Running
12	Brake test OK	Brake test failed
13	Voltage OK	Above limit
14	Torque OK	Above limit
15		Thermal warning

Bit 00, Control not ready/ready:

Bit 00 = '0' means that the frequency converter has tripped.

Bit 00 = '1' means that the frequency converter controls are ready, but that the power component is not necessarily receiving any power supply (in case of external 24 V supply to controls).

Bit 01, Drive ready:

Bit 01 = '1'. The frequency converter is ready for operation, but there is an active coasting command via the digital inputs or via serial communication.

Bit 02, Coasting stop:

Bit 02 = '0'. The frequency converter has released the motor.

Bit 02 = '1'. The frequency converter can start the motor when a start command is given.

Bit 03, No trip/trip:

Bit 03 = '0' means that the frequency converter is not in fault mode.

Bit 03 = '1' means that the frequency converter is tripped, and that it needs a reset signal for operation to be reestablished.

Bit 04, Not used:

Bit 04 is not used in the status word.

Bit 05, Not used:

Bit 05 is not used in the status word.

Bit 06, Not used:

Bit 06 is not used in the status word.

Bit 07, No warning/warning:

Bit 07 = '0' means that there are no warnings.

Bit 07 = '1' means that a warning has occurred.

Bit 08, Speed≠ ref/speed = ref.:

Bit 08 = '0' means that the motor is running, but that the present speed is different from the preset speed reference. It might, for example, be the case while the speed is being ramped up/down during start/stop.

Bit 08 = '1' means that the motor's present speed is the same as the preset speed reference.

Bit 09, Local operation/serial communication control:

Bit 09 = '0' means that [STOP/RESET] is activated on the control unit, or that *Local control* in parameter 002 *Local/remote operation* is selected. It is not possible to control the frequency converter via serial communication.

Bit 09 = '1' means that it is possible to control the frequency converter via serial communication.

Bit 10, Outside frequency range:

Bit 10 = '0', if the output frequency has reached the value in parameter 201 *Output frequency low limit* or parameter 202 *Output frequency high limit*. Bit 10 = "1" means that the output frequency is within the defined limits.

Bit 11, Running/not running:

Bit 11 = '0' means that the motor is not running.

Bit 11 = '1' means that the frequency converter has a start signal or that the output frequency is greater than 0 Hz.

Bit 12, Brake test:

Bit 12 = '0' means brake test OK.

Bit 12 = '1' means brake test failed.

Bit 13, Voltage warning high/low:

Bit 13 = '0' means that there are no voltage warnings.

Bit 13 = '1' means that the DC voltage in the frequency converter's intermediate circuit is too low or too high.

Bit 14, Torque OK/ above limit:

Bit 14 = '0' means that the motor current is lower than the torque limit selected in parameter 221.

Bit 14 = '1' means that the the torque limit in parameter 221 has been exceeded.

Bit 15, Thermal warning:

Bit 15 = '0' means that there is no thermal warning.

Bit 15 = '1' means that the temperature limit has been exceeded either in the motor, in the frequency converter, or from a thermistor connected to an analog input.

■ Control word according to Fieldbus Profile

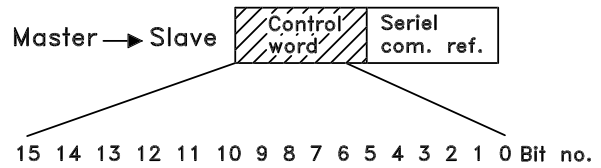

To select *Profidrive* in the control word, parameter 512 *Telegram Profile* must be set to *Profidrive* [0].

The control word is used to send commands from a master (e.g. a PC) to a slave (frequency converter). Master Slave.

Bit	Bit = 0	Bit =1
00	OFF 1	ON 1
01	OFF 2	ON 2
02	OFF 3	ON 3
03	Coasting stop	
04	Quick stop	
05	Freeze outp. freq.	
06	Ramp stop	Start
07	Reset	
08	Bus jog 1	
09	Bus jog 2	
10	Data not valid	Data not valid
11	Slow down	
12	Catch-up	
13	Select Setup (lsb)	
14	Select Setup (msb)	
15	Reversing	

Bit 00-01-02, OFF1-2-3/ON1-2-3:

Bit 00-01-02 = '0' causes ramp stop, which uses the ramp time in parameters 207/208 or 209/210.

If *Relay 123* is selected in parameter 323 *Relay output*, the output relay will be activated when the output frequency is 0 Hz.

Bit 00-01-02 = '1' means that the frequency converter can start the motor if the other starting conditions are fulfilled.

Bit 03, Coasting stop:

See description under *Control word according to FC protocol*.

Bit 04, Quick stop:

See description under *Control word according to FC protocol*.

Bit 05, Freeze output frequency:

See description under *Control word according to FC protocol*.

Bit 06, Ramp stop/start:

See description under *Control word according to FC protocol*.

Bit 07, Reset:

See description under *Control word according to FC protocol*.

Bit 08, Jog 1:

Bit 08 = "1" means that the output frequency is determined by parameter 09 *Bus jog 1*.

Bit 09, Jog 2:

Bit 09 = "1" means that the output frequency is determined by parameter 510 *Bus jog 2*.

Bit 10, Data not valid/Data valid:

See description under *Control word according to FC protocol*.

Bit 11, Slow-down:

Used to reduce the speed reference by the value in parameter 219 *Catch-up/slow-down reference*.
 Bit 11 = '0' does not cause any change to the reference.
 Bit 11 = '1' means that the reference is reduced.

Bit 12, Catch-up:

Used to increase the speed reference by the value in parameter 219 *Catch-up/slow-down reference*.
 Bit 12 = '0' does not cause any change to the reference.
 Bit 12 = '1' means that the reference is increased.
 If both *Slow down* and *Catch-up* are activated (Bits 11 and 12 = "1"), slow down has the highest priority, i.e. that the speed reference is reduced.

Bit 13/14, Selection of Setup:

See description under *Control word according to FC protocol*.

Bit 15 Reversing:

See description under *Control word according to FC protocol*.

■ **Status word according to Fieldbus Profile**

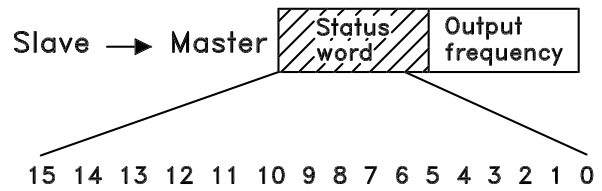

The status word is used to inform the master (e.g. a PC) of the slave's (frequency converter) mode. Slave Master.

Bit	Bit = 0	Bit = 1
00		Control ready
01		Drive ready
02	Coasting stop	
03	No trip	Trip
04	ON 2	OFF 2
05	ON 3	OFF 3
06	Start enable	Start disable
07		Warning
08	Speed ≠ ref.	Speed = ref.
09	Local control	Ser. communi.
10	Outside frequency range	Frequency limit OK
11		Motor running
12		
13		Voltage warn.
14		Current limit
15		Thermal warn.

Bit 00, Control not ready/ready:

Bit 00 = '0' means that the Bit 00, 01 or 02 in the control word are '0' (OFF1, OFF2 or OFF3) or the frequency converter is not ready for operation.
 Bit 00 = '1' means that the frequency converter is ready for operation.

Bit 01, Drive ready:

See description under *Status word according to FC protocol*.

Bit 02, Coasting stop:

Bit 02 = '0' means that Bits 00, 02 or 03 in the control word are "0" (OFF1, OFF3 or Coasting stop).
 Bit 02 = '1' means that Bits 00, 01, 02 and 03 in the control word are "1", and that the frequency converter has not tripped.

Bit 03, No trip/trip:

See description under *Status word according to FC protocol*.

Bit 04, ON 2/OFF 2:

Bit 04 = '0' means that Bit 01 in the control word = '1'.
 Bit 04 = '1' means that Bit 01 in the control word = '0'.

Bit 05, ON 3/OFF 3:

Bit 05 = '0' means that Bit 02 in the control word = '1'.
 Bit 05 = '1' means that Bit 02 in the control word = '0'.

Bit 06, Start enable/start disable:

Bit 06 = '1' after reset of a trip, after activation of OFF2 or OFF3 and after connection of mains voltage. *Start disable* is reset by setting Bit 00 in the control word to '0', and Bit 01, 02 and 10 are set to '1'.

Bit 07, Warning:

See description under *Status word according to FC protocol*.

Bit 08, Speed:

See description under *Status word according to FC protocol*.

Bit 09, No warning/warning:

See description under *Status word according to FC protocol*.

Bit 10, Speed ≠ ref/speed = ref.:

See description under *Status word according to FC protocol*.

Bit 11, Running/not running:

See description under *Status word according to FC protocol*.

Bit 13, Voltage warning high/low:

See description under *Status word according to FC protocol*.

Bit 14, Current limit:

See description under *Status word according to FC protocol*.

Bit 15, Thermal warning:

See description under *Status word according to FC protocol*.

Serial communication reference

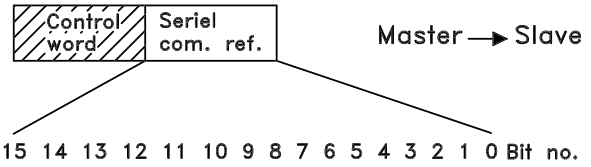

The serial communication reference is transferred to the frequency converter as a 16-bit word. The value is transferred in whole numbers 0 - ±32767 (±200%). 16384 (4000 Hex) corresponds to 100%.

The serial communication reference has the following format: 0-16384 (4000 Hex) ≅ 0-100% (Par. 204 *Minimum ref.* - Par. 205 *Maximum ref.*).

It is possible to change the direction of rotation via the serial reference. This is done by converting the binary reference value to 2' complement. See example.

Example - Control word and serial communication ref.:

The frequency converter is to receive a start command and the reference is to be set to 50% (2000 Hex) of the reference range.

Control word = 047F Hex Start command.

Reference = 2000 Hex 50% reference.

047F H	2000 H
Control word	Reference

The frequency converter is to receive a start command and the reference is to be set to -50% (-2000 Hex) of the reference range.

The reference value is first converted to 1' complement, and then 1 is added binarily to obtain 2' complement:

2000 Hex	0010 0000 0000 0000 0000
1' complement	1101 1111 1111 1111 1111
	+ 1
2' complement	1110 0000 0000 0000 0000

Control word = 047F Hex Start command.

Reference = E000 Hex -50% reference.

047F H	E000 H
Control word	Reference

Serial communication

■ **Present output frequency**

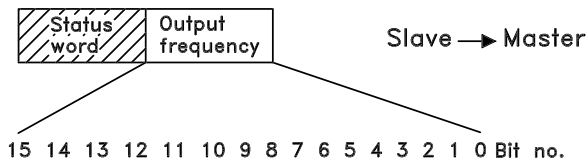

The value of the frequency converter's present output frequency is transferred as a 16-bit word. The value is transferred as whole numbers 0 - ±32767 (±200%). 16384 (4000 Hex) corresponds to 100%.

Output frequency has the following format:
 0-16384 (4000 Hex) \cong 0-100% (Par. 201
Output frequency low limit - Par. 202 *Output frequency high limit*).

Example - Status word and current output frequency:

The master receives a status message from the frequency converter that the current output frequency is 50% of the output frequency range.

Par. 201 *Output frequency low limit* = 0 Hz

Par. 202 *Output frequency high limit* = 50 Hz

Status word = 0F03 Hex.

Output frequency = 2000 Hex 50% of the frequency range, corresponding to 25 Hz.

0F03 H	2000 H
Status word	Output frequency

■ Telegram example

Telegram to the frequency converter:

■ Example 1: For Controlling the Drive and Reading Parameters

This telegram reads parameter 520, motor current.

stx	lge	adr	pke		ind		pwe, high		pwe, low		pcd 1		pcd 2		bcc
02	0E	01	12	08	00	00	00	00	00	00	00	00	00	00	17

All numbers are in hex format.

520 multiplied by 100. This means that if the actual output current is 5.24 A then the value coming from the frequency converter is 524.

The response from the frequency converter will correspond to the command above, but *pwe,high* and *pwe,low* will contain the actual value of parameter

Response from the frequency converter:

stx	lge	adr	pke		ind		pwe, high		pwe, low		pcd 1		pcd 2		bcc
02	0E	01	22	08	00	00	00	00	02	0C	06	07	00	00	28

All numbers are in hex format.

it will be possible to control the drive and read the current at the same time.

Pcd 1 and *pcd 2* from example 2 can be used and added to the example which means that

■ Example 2: Only for Controlling the Drive

This telegram sets the control word to 047C Hex (Start command) with a speed reference of 2000 Hex (50%).



NB!:

Parameter 512 is set to FC Drive.

Telegram to the frequency converter:

stx	lge	adr	pcd 1		pcd 2		bcc
02	06	04	04	7C	20	00	58

All numbers are in hex format.

The response from the frequency converter gives information of the status of the drive when it received the command. By sending the command again, the *pcd1* will change to the new status.

Response from the frequency converter:

stx	lge	adr	pcd 1		pcd 2		bcc
02	06	04	06	07	00	00	01

All numbers are in hex format.

■ Read parameter description elements

With *Read Parameter Description Elements* it is possible to read the characteristics of a parameter which could be eg. *Name*, *Default value*, *conversion*, etc.

The table below shows the available parameter description elements:

Index	Description
1	Basic characteristics
2	No of elements (array types)
4	Unit of measure
6	Name
7	Lower limit
8	Upper limit
20	Default value
21	Additional characteristics

In the following example *Read Parameter Description Elements* is chosen on parameter 001, *Language*, and the requested element is index 1 *Basic characteristics*.

Basis characteristics (index 1):

The Basic characteristics command is split up in two parts representing basic behaviour and datatype. The Basic characteristics return a 16 bit value to the master in *PWE_{Low}*.

The basic behaviour indicates whether eg. text is available or the parameter is an array as single bit information in the high byte of *PWE_{Low}*.

The datatype part indicates if a parameter is signed 16, unsigned 32 in the low byte of *PWE_{Low}*.

PWE high basic behaviour:

Bit	Description
15	Active parameter
14	Array
13	Parameter value can only be reset
12	Parameter value different from factory setting
11	Text available
10	Additional text available
9	Read only
8	Upper and lower limit not relevant
0-7	Data type

Active parameter is only active when communicating through Profibus.

Array means that the parameter is an array.

If bit 13 is true, the parameter can only be reset, not written to.

If bit 12 is true, the parameter value is different from the factory setting.

Bit 11 indicates that text is available.

Bit 10 indicates that additional text is available. Eg. parameter 001, *Language*, contains text for index field 0, *English*, and for index field 1, *German*.

If bit 9 is true, the parameter value is read-only and cannot be changed.

If bit 8 is true, upper and lower limits of the parameter value are not relevant.

PWE_{LOW} datatype

Dec.	Datatype
3	Signed 16
4	Signed 32
5	Unsigned 8
6	Unsigned 16
7	Unsigned 32
9	Visible string
10	Byte string
13	Time difference
33	Reserved
35	Bit sequence

Example

In this example, the master reads the Basic characteristics of parameter 001, *Language*.

The following telegram must be sent to the frequency converter:

STX	LGE	ADR	PKE	IND	PWE _{HIGH}	PWE _{LOW}	PCD1	PCD2	BCC
02	0E	01	40 01	00 01	00 00	00 00	XX XX	XX XX	XX

STX = 02 Start byte
 LGE = 0E Length of remaining telegram
 ADR = Sends the frequency converter on Address 1, Danfoss format
 PKE = 4001; 4 in the PKE field indicates a *Read Parameter Description* and 01 indicates parameter number 001, *Language*
 IND = 0001; 1 indicates that *Basic characteristics* are required.

The response from the frequency converter will be:

STX	LGE	ADR	PKE	IND	PWE _{HIGH}	PWE _{LOW}	PCD1	PCD2	BCC
02	0E	01	30 01	00 01	00 00	04 05	XX XX	XX XX	XX

PKE = 02 Start byte IND = 0001; 1 indicates that *Basic characteristics* are sent
 PWE_{LOW} = 0405; 04 indicates that Basic behaviour as bit 10 corresponds to *Additional text*. 05 is the datatype which corresponds to *Unsigned 8*.

No of elements (index 2):

This function indicates the Number of elements (array) of a parameter. The answer to the master will be in PWE_{LOW}.

Conversion and Unit of measurement (index 4):

The Conversion and unit of measurement command indicates the conversion of a parameter and the unit of measurement. The answer to the master will be in PWE_{LOW}. The conversion index will be in the high byte of PWE_{LOW} and the unit index will be in the low byte

of PWE_{Low} . Note that conversion index is signed 8 and unit index is unsigned 8, see tables below.

The unit index defines the "Unit of measure". The conversion index defines how the value should be scaled to get the basic representation of the "Unit of measure". Basic representation is where conversion index equals "0".

Example:

A parameter has a "unit index" of 9 and a "conversion index" of 2. The raw (integer) value read is 23. This means that we have a parameter of the unit "Power" and the raw value should be multiplied by 10 to the power of 2 and the unit is W. $23 \times 10^2 = 2300$ W

Table for conversion and unit of measurement

Unit index	Unit of measure	Designation	Conversion index
0	Dimensionless		0
4	Time	s	0
		h	74
8	Energy	j	0
		kWh	
9	Power	W	0
		kW	3
11	Speed	1/s	0
		1/min (RPM)	67
16	Torque	Nm	0
17	Temperature	K	0
		°C	100
21	Voltage	V	0
22	Current	A	0
24	Ratio	%	0
27	Relative change	%	0
28	Frequency	Hz	0

Conversion index	Conversion factor
0	1
1	10
2	100
3	1000
-1	0.1
-2	0.01
-3	0.001
67	1/60
74	3600
75	3600000
100	1

Name (index 6):

The Name returns a string value in ASCII format, containing the name of the parameter.

In this example the master reads the name of parameter 001, *Language*.

The following telegram must be sent to the frequency converter:

STX	LGE	ADR	PKE	IND	PWE _{HIGH}	PWE _{LOW}	PCD1	PCD2	BCC
02	0E	01	40 01	00 06	00 00	00 00	XX XX	XX XX	XX

STX = 02 Start byte
 LGE = 0E Length of remaining telegram
 ADR = Sends the frequency converter on Address 1, Danfoss format
 PKE = 4001; 4 in the PKE field indicates a *Read Parameter Description* and 01 indicates parameter number 001, *Language*
 IND = 0006; 6 indicates that *Names* is required.

The response from the frequency converter will be:

STX	LGE	ADR	PKE	IND	PVA	PCD1	PCD2	BCC
02	12	01	30 01	00 06	4C41 4E47 5541 4745	XXXX	XXXX	XX

PKE = 3001; 3 are the response for *Name* and 01 indicates the parameter number 001, *Language*
 IND = 00 06; 06 indicates that *Name* is sent.
 PVA = 4C 41 4E 47 55 41 47 45
 L A N G U A G E

Bit	Description
0	Special Default Value
1	Special Upper Limit
2	Special Lower Limit
7	LCP Access LSB
8	LCP Access MSB
9	NoBusAccess
10	Std Bus Read Only
11	Profibus Read Only
13	ChangeRunning
15	PowerUnitDependency

The parameter value channel is now set up to a visible string which returns an ASCII character for each letter in the parameter name.

If one of bit 0 *Special Default Value*, bit 1 *Special Upper Limit* and bit 2 *Special Lower Limit* are true, the parameter has power unit depending values.

Lower limit (index 7):

The Lower limit returns the minimum allowed value of a parameter. The data type of Lower limit is the same as for the parameter itself.

Bit 7 and 8 indicates the attributes for the LCP access, see table.

Upper limit (index 8):

The Upper limit returns the maximum allowed value of a parameter. The data type of Upper limit is the same is for the parameter itself.

Bit 8	Bit 7	Description
0	0	No access
0	1	Read only
1	0	Read/write
1	1	Write with lock

Default value (index 20):

The Default value returns the default value of a parameter, which is the factory setting. The data type of Default value is the same as for the parameter itself.

Bit 9 indicates *No bus Access*.

Additional characteristics (index 21):

The command can be used for getting some additional information on a parameter, eg. *No bus Access*, *Power Unit dependency*, etc.. The Additional characteristics returns an answer in PWE_{LOW}. If a bit is logic '1', the condition is true according to the table below:

Bits 10 and 11 indicates that this parameter can only be read over the bus.

If bit 13 is true, the parameter cannot be changed while running.

If bit 15 is true, the parameter is depending on the power unit.

■ Additional Text

With this feature it is possible to read additional text if bit 10, *Additional text available*, is true in Basic characteristics.

To read out additional text, the parameter command (PKE) must be set to F hex, see *Databytes*.

The index-field is used for pointing out which element to be read. Valid indexes are in the range

of 1 through 254. The index must be calculated after the following equation:

Index = Parameter value + 1 (see table below).

Value	Index	Text
0	1	English
1	2	Deutsch
2	3	Français
3	4	Dansk
4	5	Espanol
5	6	Italiano

Example:

In this example, the Master reads additional text in parameter 001, *Language*. The telegram is

STX	LGE	ADR	PKE	IND	PWE _{HIGH}	PWE _{LOW}	PCD1	PCD2	BCC
02	0E	01	F0 01	00 01	00 00	00 00	XX XX	XX XX	XX

STX = 02 Start byte
 LGE = 0E Length of the remaining telegram
 ADR = Send the VLT frequency converter on Address 1, Danfoss format
 PKE = F001; F in the PKE field indicates a *Read text* and 01 indicates parameter number 001, *Language*.
 IND = 0001; 1 indicates that text to parameter value [0] is required

set up to read datavalue [0] which corresponds to *English*. The following telegram must be sent to the VLT frequency converter:

The response from the VLT frequency converter will be:

STX	LGE	ADR	PKE	IND	PVA	PCD1	PCD2	BCC
02	11	01	F0 01	00 01	45 4E 47 4C 49 53 48	XX XX	XX XX	XX

PKE = F001; F is the response for *Text transfer* and 01 indicates parameter number 001, *Language*.
 IND = 0001; 1 indicates that index [1] is sent
 PVA = 45 4E 47 4C 49 53 48
 E N G L I S H

The parameter value channel is now set up to a visible string, which returns an ASCII character for each letter in the index name.

Conveyor belt

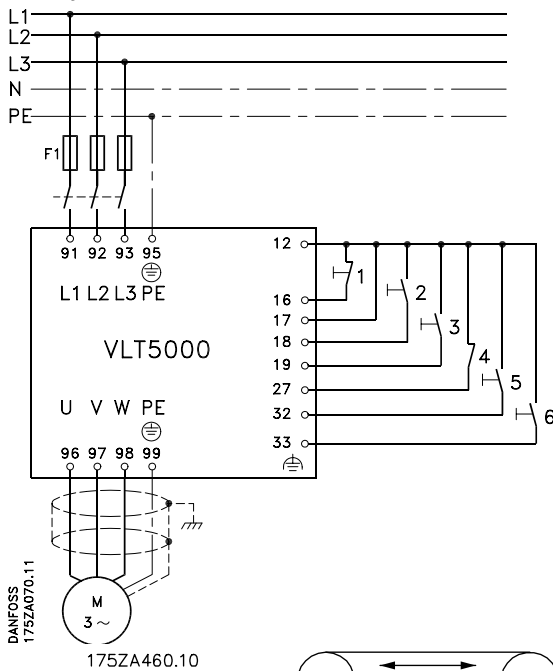

A conveyor belt is to be controlled using the digital inputs. Start the conveyor belt going to the right (clockwise) via switch 2 and to the left (anti-clockwise) via switch 3. The reference will increase as long as switch 5 (speed up) is active and will be reduced when switch 6 (speed down) is active. A stop via the ramp can be activated by means of contact 1; quick-stop by means of switch 4.

1. Pulse stop (inverse)
2. Pulse start to the right
3. Pulse start to the left
4. Quick-stop
5. Speed up
6. Speed down

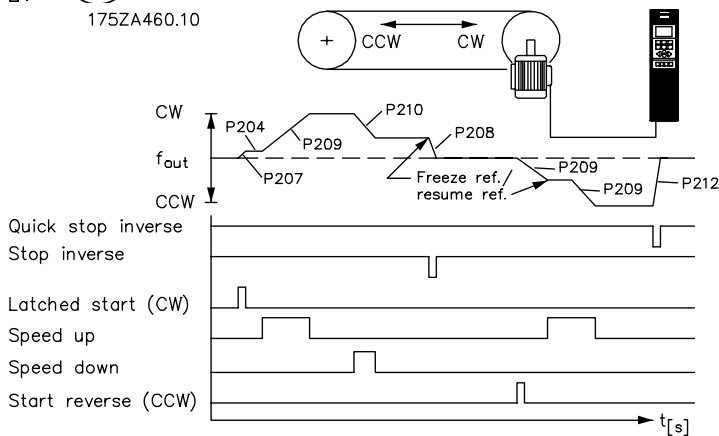

The following must be programmed in order shown:

Function:	Parameter:	Setting:	Data value:
Rotation, frequency/direction	200	Both directions, 0-132 Hz	[1]
Minimum reference	204	3-10 (Hz)	
Ramp-up time 1	207	10-20 sec.	
Ramp-down time 1	208	10-20 sec.	
Ramp-up time 2	209	10-20 sec.	
Ramp-down time 2	210	10-20 sec.	
Digital input, term. 16	300	Stop (inverse)	[2]
Digital input, term. 17	301	Freeze reference	[7]
Digital input, term. 18	302	Pulse start	[2]
Digital input, term. 19	303	Start reversing	[2]
Digital input, term. 27	304	Quick-stop (inverse)	[2]

All other settings are based on factory settings. However, motor data (nameplate data) must always be entered in parameters 102-106.

■ Pump

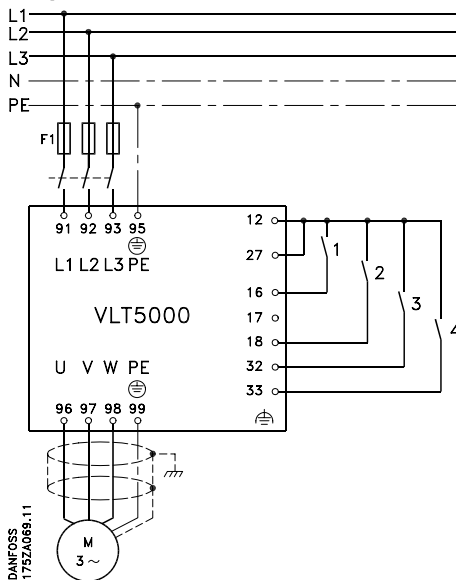

175ZA461.10

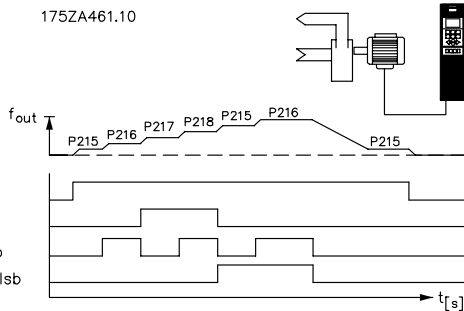

A pump is to run at six different speeds, determined by shifting between the preset references.

Switch no.:			
1	3	4	
0	0	0	Preset reference 1
0	0	1	Preset reference 2
0	1	0	Preset reference 3
0	1	1	Preset reference 4
1	0	0	Preset reference 5
1	0	1	Preset reference 6

When switch 1 is active, a setup change to setup 2 is made.

Start/stop by means of switch 2

1. Choice of Setup, lsb
2. Start/stop
3. Preset reference, lsb
4. Preset reference, msb

The following must be programmed in order shown:

Function:	Parameter:	Setting:	Data value:
Active Setup	004	Multi-Setup	[5]
Digital input, term. 16	300	Choice of Setup, lsb	[10]
Digital input, term. 32	306	Preset reference, lsb	[6]
Digital input, term. 33	307	Preset reference, msb	[6]
Setup copying	006	Copy to Setup 2 from #	[2]
Edit Setup	005	Setup 1	[1]
Maximum reference	205	60	
Preset reference 1	215	10%	
Preset reference 2	216	20%	
Preset reference 3	217	30%	
Preset reference 4	218	40%	
Edit Setup	005	Setup 2	[2]
Maximum reference	205	60	
Preset reference 5	215	70%	
Preset reference 6	216	100%	

All other settings are based on factory settings. However, motor data (nameplate data) must always be entered in parameters 102-106.

■ Gantry Crane

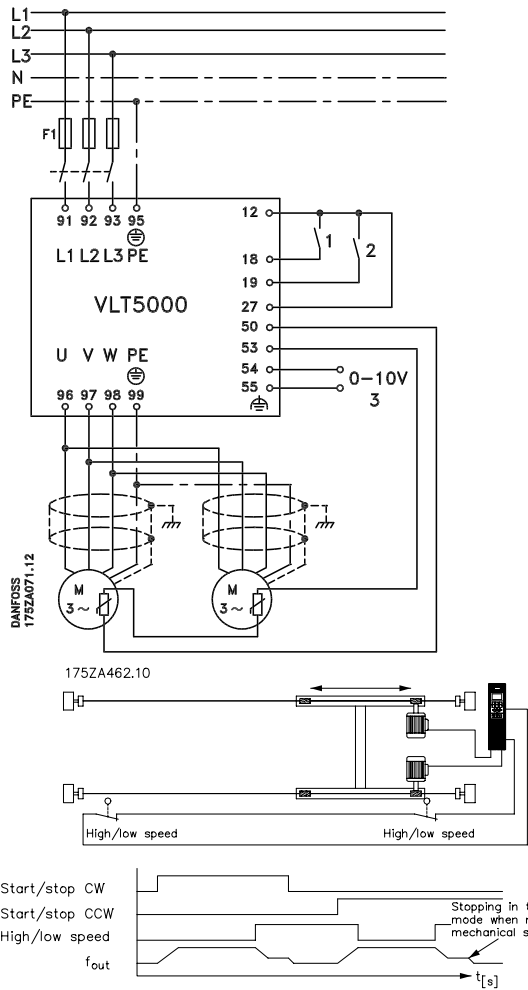

A portal gantry with two identical motors is controlled by an external 0-10 Volt signal. The direction of rotation (right or left) is controlled by means of switch 2, while start/stop is carried out using switch 1.

1. Start
2. Reversing
3. Speed reference signal

The following must be programmed in order shown:

Function:	Parameter:	Setting:	Data value:
Torque characteristics	101	Normal/special motor character	[15]
Rotation, frequency/direction	200	Both directions, 0 - 132 Hz	[1]
Analogue input, term. 53	308	Thermistor	[4]
Motor thermal protection	128	Thermistor warning/Thermistor trip	[1] or [2]
Analogue input, term. 54	311	Reference	[1]
Terminal 18, digital input	302	Start	[1]
Terminal 27, digital input	304	Coasting stop inverse	[0]
Terminal 42, output	319	Torque limit and stop	[27]

All other settings are based on factory settings. However, motor data (nameplate data) must always be entered in parameters 102-106.

■ Torque control, speed feedback

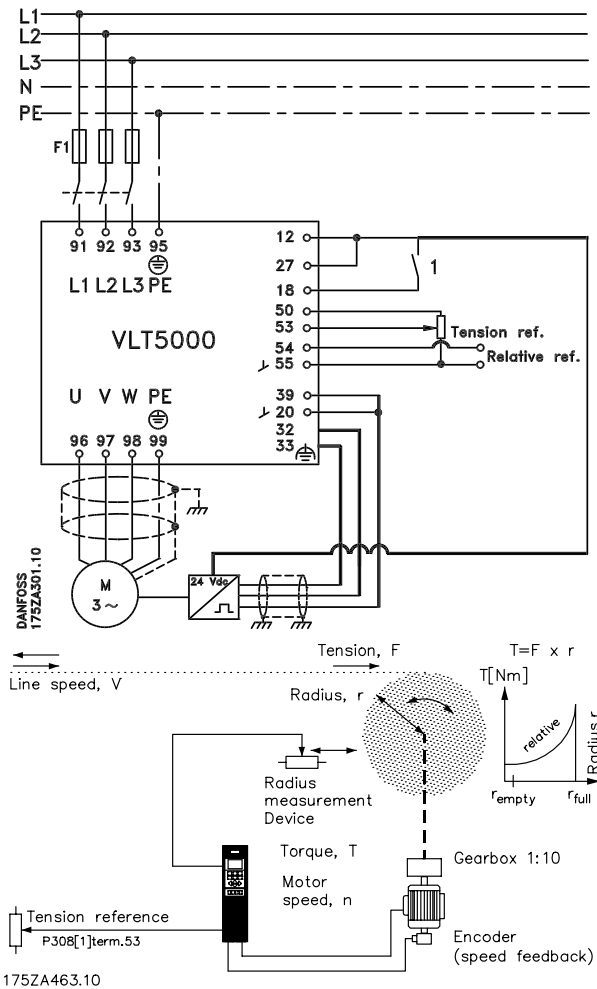

A winder winds material onto a roll or unwinds material from a roll at a constant tension.

A device measures the radius of the roll and adjusts the motor torque to ensure that the tension is constant. The measuring device must have a non-linear output signal.

The following must be programmed in order shown:

Function:	Parameter:	Setting:	Data value:
Configuration	100	Torque control, speed feedback[5]	
Rotation, frequency/direction	200	Both directions, 0-132 Hz [1]	
Reference/feedback range	203	-Max. - +Max.	[1]
Minimum reference	204	Set to min. torque (Nm)	
Maximum reference	205	Set to max. torque (Nm)	
Reference function	214	Relative	[1]
Terminal 32, encoder input A	306	Encoder feedback, input A	[25]
Terminal 33, encoder input B	307	Encoder feedback, input B	[24]
Encoder feedback, pulses/rev.	329	Set to encoder pulses per rev.	
Terminal 53, analogue input	308	Reference	[1]
Terminal 54, analogue input	311	Relative reference	[4]
Speed PID lowpass filter	421	10 msec.	

■ VLT 5000 controllers

VLT 5000 has three inbuilt controllers: one for speed control, one for process control and one for torque control.

Speed control and process control are in the form of a PID controller that requires a feedback to an input. Torque control is in the form of a PI controller that does not require a feedback, since the torque is calculated by the VLT frequency converter on the basis of the current measured.

Setting of speed and process controller

With respect to both PID controllers, there are a number of settings which are made in the same parameters; however, the choice of controller type will affect the choices to be made under the common parameters. In parameter 100 *Configuration*, a choice is made of controller, *Speed control, closed loop* or *Process control, closed loop*.

Feedback signal:

A feedback range must be set for both controllers. This feedback range at the same time limits the possible reference range, which means that if the sum of all references is outside the feedback range, the reference will be limited to being within this range. The feedback range is set in the units that belong to the application (Hz, RPM, bar, °C, etc.). Setting is effected directly in a parameter for the individual input terminal, thereby deciding whether it should be used for feedback in connection with one of the controllers. Inputs that are not used can be disabled, which will ensure that they do not disturb control. If feedback has been selected on two terminals at the same time, these two signals will be added up.

Reference:

For both controllers, it is possible to set four preset references. These can be set between -100% and +100% of the maximum reference or the sum of the external references. External references can be analogue signals, pulse signals and/or serial communication. All references will be added and the sum will be the reference for subsequent regulation. It is possible to limit the reference range to a range smaller than the feedback range. This can be an advantage if it is to be avoided that an unintended change of an external reference makes the sum of references move too far away from the optimum reference. As with the feedback range, the reference range is set in the units that belong to the applications in question.

Speed control:

This PID control has been optimized for use in applications with a need to maintain a given motor speed.

The parameters that are specific to the speed controller are parameters 417 to 421.

PID for process control:

This PID control has been optimized for process control. This controller does not have a feedforward facility, but a number of special features that are relevant to process control.

There is a choice of whether normal control is required, in which the speed is increased in the case of an error between the reference and the feedback, or whether inverse control is to be applied, in which the speed is reduced in the case of an error.

There is also a choice of whether the integrator is to continue integrating in the case of an error, even if VLT 5000 is at the minimum/maximum frequency or at the current limit. If VLT 5000 is in such a borderline situation, any attempt to change the motor speed will be restricted by this limit. The integrator comes from the works preset to stop integrating. Integration will be adjusted to a gain that corresponds to the given output frequency.

In certain applications, it is either difficult or completely impossible to measure such a factor as the level. In such cases, it can be necessary to allow the integrator to continue integrating on the fault, even if the motor speed cannot be changed. This will make the integrator work as a kind of counter, i.e. once the feedback indicates that the speed must be changed in a direction away from the borderline situation, the integration will give this change a delay that depends on the time for which the integrator has overcompensated for the previous error.

Furthermore, it is possible to program a starting frequency in which VLT 5000 will wait without activating the controller until this frequency has been reached. This makes it possible, for example, to quickly build up the necessary static pressure in a pumping system.

PID process control, continued:

The Proportional gain, Integration time and Differentiation time of the process controller are set in individual parameters, and the setting ranges are adapted to process control requirements.

As in speed control, it is possible to limit the influence of the differentiator in relation to swift changes in the error between the reference and the feedback signal.

Also available is a lowpass filter for the process controller. This can be set to remove a much greater share of the feedback signal oscillations than the lowpass filter of the speed controller does. This is because most fans and pump applications react relatively slowly, which is why it can be an advantage to feed as stable a signal as possible to the process controller.

The parameters that are specific to the process controller are parameters 437 to 444.

Setting of torque controller (open loop):

This control is selected if *Torque control, open loop* has been selected in 100 *Configuration*.

When this mode has been selected, the reference will use the Nm unit.

Control is in the form of a PI that requires no feedback, since the torque is calculated on the basis of the current measurement of VLT 5000. The proportional gain is set as a percentage in parameter 433 *Torque proportional gain* and the integration time is set in parameter 434 *Torque integration time*. However, both these have been set at the works and normally require no modification.

■ PID for process control

The following is an example of a process controller used in a ventilation system.

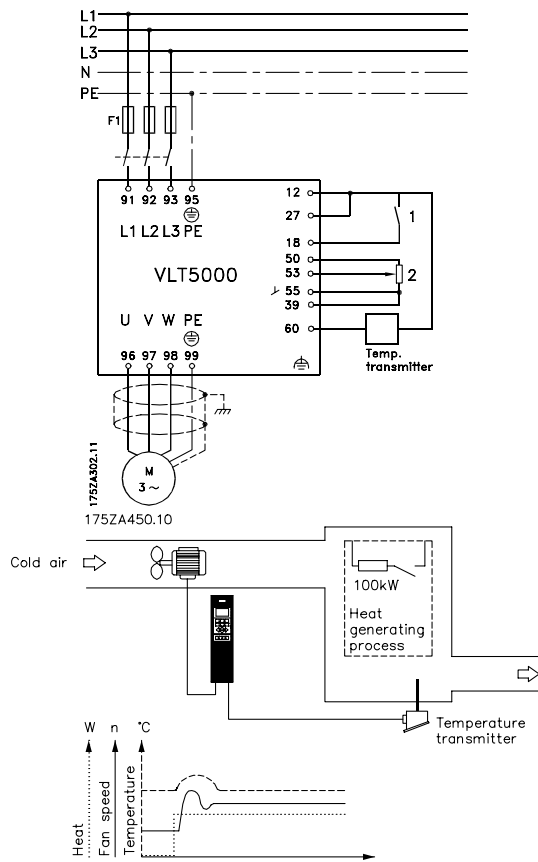

In a ventilation system, the temperature is to be settable from - 5 - 35°C with a potentiometer of 0-10 Volt. The set temperature must be kept constant, for which purpose the integrated process controller is to be used. The control is of the inverse type, which means that when the temperature increases, the ventilation speed is increased as well, so as to generate more air. When the temperature drops, the speed is reduced. The transmitter used is a temperature sensor with a working range of -10-40°C, 4-20 mA. Min./Max. speed 10/50 Hz.



NB!:

The example shows a two-wire transmitter.

1. Start/Stop
2. Temperature reference -5-35°C, 0-10 V (setpoint)
3. Temperature transmitter -10-40°C, 4-20 mA (feedback).

The following must be programmed in order shown - see explanation of settings in the Operating Instructions:

Function:	Parameter no.	Setting	Data value no.
Activation of process controller	100	<i>Process control, closed loop</i>	[3]
Feedback signal	314	<i>Feedback signal</i>	[2]
Terminal 60, min. scale	315	4 mA	
Terminal 60, max. scale	316	20 mA (factory setting)	
Minimum feedback	414	-10°C	
Maximum feedback	415	40°C	
Process units	416	°C	[10]
Reference	308	<i>Reference (factory setting)</i>	[1]
Terminal 53, min. scale	309	0 Volt (factory setting)	
Terminal 53, max. scale	310	10 Volt (factory setting)	
Minimum reference	204	-5°C	
Maximum reference	205	35°C	
Inverse control	437	<i>Inverse</i>	[1]
Min. frequency	201	10 Hz	
Max. frequency	202	50 Hz	
Proportional gain	440	<i>Application-dependent (e.g. 1.0)</i>	
Integration time	441	<i>Application-dependent (e.g. 5 sec.)</i>	

■ PID for speed control

Below are given a couple of examples of programming of VLT 5000 PID speed control.

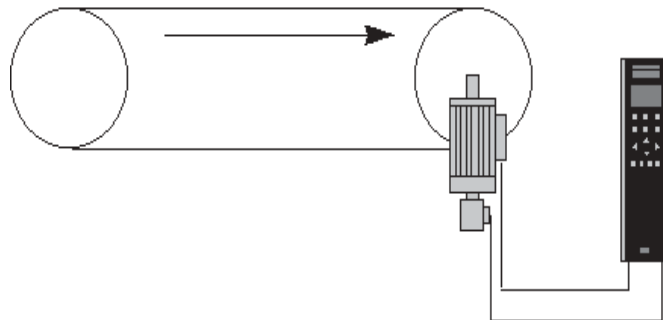
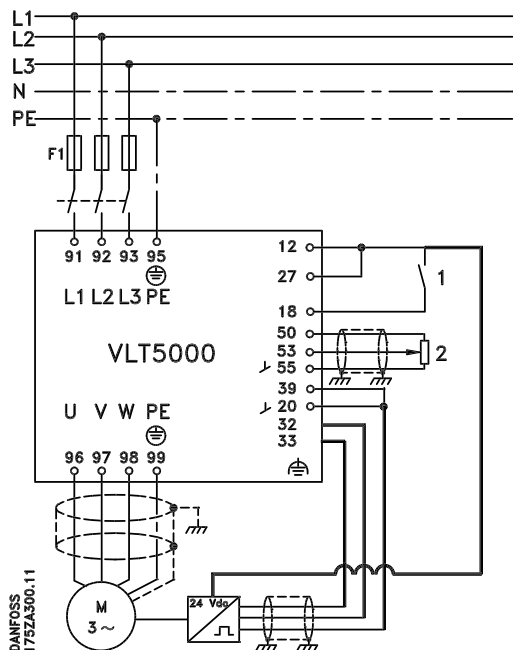

175ZA451.10

A conveyor belt that carries heavy items must be maintained at a regular speed, which is set by means of a potentiometer within the range of 0-1500 rpm, 0-10 Volts. The speed selected must be kept constant and the integrated PID speed controller is to be applied. This is a case of normal control, which means that when the load increases, the power supplied to the conveyor belt motor increases in order to keep the speed constant. Correspondingly, when the load falls, the power is reduced. The feedback used is an encoder with a resolution of 1024 pulses/rev. push-pull.

1. Start/Stop
2. Speed reference 0-1500 rpm, 0-10 Volts
3. Encoder 1024 pulses/rev. push-pull.

The following must be programmed in order shown - see explanation of settings in the Operating Instructions:

Function:	Parameter no.	Setting	Data value no.
Activation of process controller	100	<i>Speed control, closed loop</i>	[1]
Feedback signal	314	<i>Feedback signal</i>	[2]
Terminal 32	306	Encoder feedback, input B	[24]
Terminal 33	307	Encoder feedback, input A	[25]
Minimum feedback	414	0 rpm	
Maximum feedback	415	1650 rpm (max. ref. + 10%)	
Reference	308	<i>Reference (factory setting)</i>	[1]
Terminal 53, min. scale	309	0 Volt (factory setting)	
Terminal 53, max. scale	310	10 Volt (factory setting)	
Minimum reference	204	0 rpm	
Maximum reference	205	1500 rpm	
Min. speed	201	0 Hz	
Max. speed	202	75 Hz	
Proportional gain	417	<i>Application-dependent</i>	
Integration time	418	<i>Application-dependent</i>	
Differentiation time	419	<i>Application-dependent</i>	

■ PID for torque controller (open loop)

Below is given an example of programming of VLT 5000 torque controller.

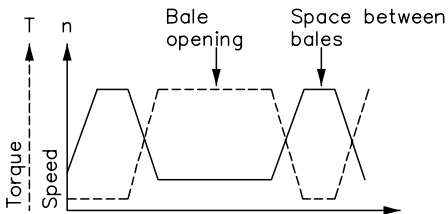
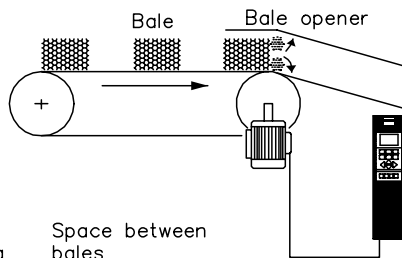
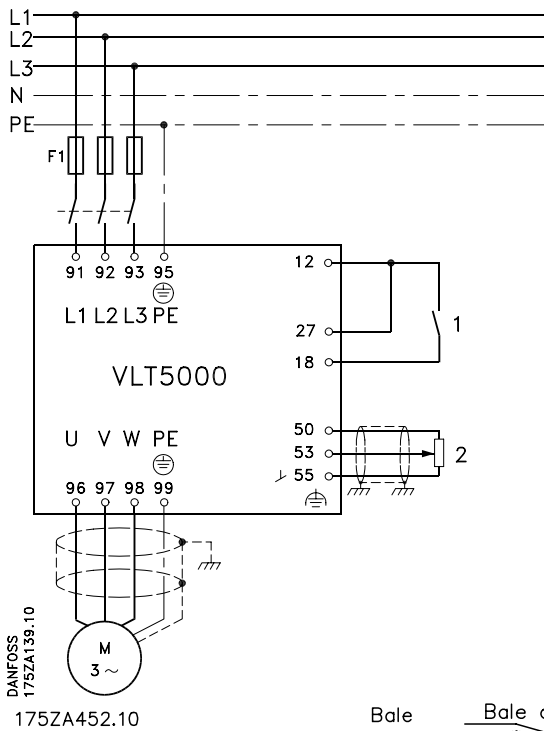

A conveyor belt is used for carrying bales forward to a shredder at constant force, regardless of the conveyor belt speed. If there is a space between bales, the conveyor belt must move the next bale to the shredder as quickly as possible.

1. Start/stop.
2. Reference [Nm]

Optimisation of the torque controller

The basic settings have now been made and the factory setting has been optimised for most processes. It is rarely necessary to optimize the *torque proportional gain* in parameter 433 and the *torque integration time* in parameter 434.

In the cases where the factory setting has to be changed, it is recommended to change this setting by a maximum factor of +/- 2.

Feedback

The feedback signal is an estimated torque, calculated by the VLT frequency converter on the basis of the current values measured.

Reference

The reference is always in Nm.

A minimum and a maximum reference can be set (204 and 205) which limit the sum of all references. The reference range cannot go beyond the feedback range.

The following must be programmed in order shown:

Function:	Parameter no.	Setting	Data value no.
Activation of process controller	100	<i>Torque control, open loop</i>	[4]
Torque proportional gain	433	100% (factory setting)	
Torque integration time	434	0.02 sec (factory setting)	
Reference	308	<i>Reference</i> (factory setting)	[1]
Terminal 53, min. scale	309	0 volt (factory setting)	
Terminal 53, max. scale	310	10 volt (factory setting)	
Min. speed	201	0 Hz	
Max. speed	202	50 Hz	

■ Galvanic Isolation (PELV)

PELV offers protection by way of extra low voltage. Protection against electric shock is considered to be ensured when the electrical supply is of the PELV type and the installation is made as described in local/national regulations on PELV supplies.

All control terminals and relay terminals 01-03 comply with PELV (Protective Extra Low Voltage) (Does not apply to 525-600 V units).

Galvanic (ensured) isolation is obtained by fulfilling requirements concerning higher isolation and by providing the relevant creepage/clearance distances. These requirements are described in the EN 50178 standard.

The components that make up the electrical isolation, as described below, also comply with the requirements concerning higher isolation and the relevant test as described in EN 50178.

The galvanic isolation can be shown in five locations (see drawing below), namely:

1. Power supply (SMPS) incl. signal isolation of U_{DC} , indicating the intermediate current voltage.
2. Gate drive that runs the IGBTs (trigger transformers/opto-couplers).
3. Current transducers (Hall effect current transducers).
4. Opto-coupler, brake module.
5. Opto-coupler, 24 V external supply.

Galvanic isolation

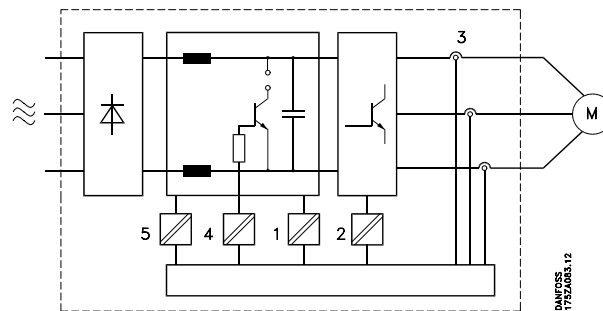

■ Earth leakage current

Earth leakage current is primarily caused by the capacitance between motor phases and the motor cable screen. When an RFI filter is used, this contributes additional leakage current, as the filter circuit is connected to earth through capacitors. The size of the leakage current to the ground depends on the following factors, in order of priority:

1. Length of motor cable
2. Motor cable with or without screen
3. Switching frequency
4. RFI filter used or not
5. Motor grounded on site or not

The leakage current is of importance to safety during handling/operation of the frequency converter if (by mistake) the frequency converter has not been earthed.



NB!:

Since the leakage current is >3.5 mA, reinforced earthing must be established, which is required if EN 50178 is to be complied with. For 3-phased frequency converters, only fault current relays which are suitable for protection against DC currents (Din VDE 0664) are to be used. RCD fault current relays type B comply with these requirements according to the norm IEC 755-2.

The following requirements must be complied with:

- Suitable for protecting equipment with a direct current content (DC) in the fault current (3-phase rectifier)
- Suitable for power-up with short pulse-shaped charging current to earth
- Suitable for a high leakage current.

■ Extreme Running ConditionsShort circuit

The frequency converter is protected against short circuits by means of current measurement in each of the three motor phases. A short circuit between two output phases will cause an overcurrent in the inverter. However, each transistor of the inverter will be turned off individually when the short circuit current exceeds the permitted value.

After 5-10 μ s the driver card turns off the inverter and the frequency converter will display a fault code, although depending on impedance and motor frequency.

Earth fault

The inverter cuts out within a few μ s in case of an earth fault on a motor phase, although depending on impedance and motor frequency.

Switching on the output

Switching on the output between the motor and the frequency converter is fully permitted. It is not possible to damage VLT 5000 Series in any way by switching on the output. However, fault messages may appear.

Motor-generated overvoltage

The voltage in the intermediate circuit is increased when the motor acts as a generator. This occurs in two cases:

1. The load drives the motor (at constant output frequency from the frequency converter), ie. the load generates energy.

2. During deceleration ("ramp-down") if the moment of inertia is high, the load is low and the ramp-down time is too short for the energy to be dissipated as a loss in the frequency converter, the motor and the installation.

The control unit attempts to correct the ramp if possible. The inverter turns off to protect the transistors and the intermediate circuit capacitors when a certain voltage level is reached.

Mains drop-out

During a mains drop-out, the frequency converter continues until the intermediate circuit voltage drops below the minimum stop level, which is typically 15% below the frequency converter's lowest rated supply voltage.

The time before the inverter stops depends on the mains voltage before the drop-out and on the motor load.

Static overload

When the frequency converter is overloaded (the torque limit in parameter 221/222 has been reached), the controls will reduce the output frequency in an attempt to reduce the load.

If the overload is excessive, a current may occur that makes the frequency converter cut out after approx. 1.5 sec.

Operation within the torque limit can be limited in time (0-60 s) in parameter 409.

■ Peak voltage on motor

When a transistor in the inverter is opened, the voltage across the motor increases by a dU/dt ratio that depends on:

- the motor cable (type, cross-section, length screened or unscreened)
- inductance

The natural induction causes an overshoot U_{PEAK} in the motor voltage before it stabilises itself at a level which depends on the voltage in the intermediate circuit. The rise time and the peak voltage U_{PEAK} affect the service life of the motor. If the peak voltage is too high, motors without phase coil insulation are the ones that will primarily be affected. If the motor cable is short (a few metres), the rise time and peak voltage are lower. If the motor cable is long (100 m), the rise time and peak voltage will increase.

If very small motors are used without phase coil insulation, it is recommended to fit a LC filter after the frequency converter. Typical values for the rise time and peak voltage U_{PEAK} are measured on the motor terminals between two phases.

To obtain approximate values for cable lengths and voltages not mentioned below, use the following rules of thumb:

1. Rise time increases/decreases proportionally with cable length.
2. $U_{PEAK} = \text{DC link voltage} \times 1.9$
(DC link voltage = Mains voltage $\times 1.35$).
3. $dU/dt = \frac{0.8 \times U_{PEAK}}{\text{Rise time}}$

Data are measured according to IEC 60034-17.

VLT 5001-5011 / 380-500 V

Cable length	Mains voltage	Rise time	Peak voltage	dU/dt
50 metres	500 V	0.5 $\mu\text{sec.}$	1230 V	1968 V/ $\mu\text{sec.}$
150 metres	500 V	1 $\mu\text{sec.}$	1270 V	1270 V/ $\mu\text{sec.}$
50 metres	380 V	0.6 $\mu\text{sec.}$	1000 V	1333 V/ $\mu\text{sec.}$
150 metres	380 V	1.33 $\mu\text{sec.}$	1000 V	602 V/ $\mu\text{sec.}$

VLT 5016-5102 / 380-500 V

Cable length	Mains voltage	Rise time	Peak voltage	dU/dt
32 metres	380 V	0.27 $\mu\text{sec.}$	950 V	2794 V/ $\mu\text{sec.}$
70 metres	380 V	0.60 $\mu\text{sec.}$	950 V	1267 V/ $\mu\text{sec.}$
132 metres	380 V	1.11 $\mu\text{sec.}$	950 V	685 V/ $\mu\text{sec.}$

VLT 5122-5302 / 380-500 V

Cable length	Mains voltage	Rise time	Peak voltage	dU/dt
70 metres	400 V	0.34 $\mu\text{sec.}$	1040 V	2447 V/ $\mu\text{sec.}$

VLT 5352-5552 / 380-500 V

Cable length	Mains voltage	Rise time	Peak voltage	dU/dt
29 metres	500 V	0.71 $\mu\text{sec.}$	1165 V	1389 V/ $\mu\text{sec.}$
29 metres	400 V	0.61 $\mu\text{sec.}$	942 V	1233 V/ $\mu\text{sec.}$

VLT 5001-5011 / 525-600 V

Cable length	Mains voltage	Rise time	Peak voltage	dU/dt
35 metres	600 V	0.36 $\mu\text{sec.}$	1360 V	3022 V/ $\mu\text{sec.}$

VLT 5016-5062 / 525-600 V

Cable length	Mains voltage	Rise time	Peak voltage	dU/dt
35 metres	575 V	0.38 $\mu\text{sec.}$	1430 V	3011 V/ $\mu\text{sec.}$

VLT 5042-5352 / 525-690 V

Cable length	Mains voltage	Rise time	Peak voltage	dU/dt
25 metres	690 V	0.59 $\mu\text{sec.}$	1425 V	1983 V/ $\mu\text{sec.}$
25 metres	575 V	0.66 $\mu\text{sec.}$	1159 V	1428 V/ $\mu\text{sec.}$
25 metres	690 V	1.72 $\mu\text{sec.}$	1329 V	640 V/ $\mu\text{sec.}$
metres	V ¹⁾	$\mu\text{sec.}$		V/ $\mu\text{sec.}$

1) With Danfoss dU/dt filter.

VLT 5402-5602 / 525-690 V

Cable length	Mains voltage	Rise time	Peak voltage	dU/dt
25 metres	690 V	0.57 μ sec.	1540	2.230 V/ μ sec.
25 metres	575 V	0.25 μ sec.		2.510 V/ μ sec.
25 metres	690 V ¹⁾	1.13 μ sec.	1629	1.150 V/ μ sec.

1) With Danfoss dU/dt filter.

■ Switching on the input

Switching on the input depends on the mains voltage in question and on whether Quick discharge of the intermediate capacitor has been selected. The table below states the waiting time between cut-ins.

Mains voltage	380 V	415 V	460 V	500 V	690 V
Without quick discharge	48 s	65 s	89 s	117 s	120 s
With quick discharge	74 s	95 s	123 s	158 s	

VLT 5042-5352 / 525 - 690 V

IP 21/NEMA 1 units:	74 dB(A)
IP 54 units:	74 dB(A)

VLT 5402 / 525 - 690 V

All enclosure types:	80 dB(A)
----------------------	----------

VLT 5502-5602 / 525 - 690 V

All enclosure types:	83 dB(A)
----------------------	----------

Measured 1 meter from the unit at full load.

Special conditions

■ Acoustic noise

The acoustic interference from the frequency converter comes from two sources:

1. DC intermediate circuit coils.
2. Integral fan.

Below are the typical values measured at a distance of 1 m from the unit at full load:

VLT 5001-5006 200 - 240 V, VLT 5001-5011 380 - 500 V

IP 20 units:	50 dB(A)
IP 54 units:	62 dB(A)

VLT 5008-5027 200 - 240 V, VLT 5016-5102 380 - 500 V

IP 20 units:	61 dB(A)
IP 20 unit (VLT 5062-5102):	67 dB(A)
IP 54 units:	66 dB(A)

VLT 5032-5052 / 200 - 240 V

IP 20/NEMA 1 units:	70 dB(A)
IP 54 units:	65 dB(A)

VLT 5122-5302 / 380 - 500 V

IP 21/NEMA 1 units:	73 dB(A)
IP 54 units:	73 dB(A)

VLT 5352 / 380 - 500 V

IP 00/ IP 21 /NEMA 1 units:	80 dB(A)
IP 54 units:	80 dB(A)

VLT 5452-5552 / 380 - 500 V

All enclosure types:	83 dB(A)
----------------------	----------

VLT 5001-5011 / 525 - 600 V

IP 20/NEMA 1 units:	62 dB(A)
---------------------	----------

VLT 5016-5062 / 525 - 600 V

IP 20/NEMA 1 units:	66 dB(A)
---------------------	----------

Derating

If the frequency converter is operated at temperatures above 45°C, a derating of the continuous output current is necessary.

Derating for ambient temperature

The ambient temperature ($T_{AMB,MAX}$) is the maximum temperature allowed. The average ($T_{AMB,AVG}$) measured over 24 hours must be at least 5°C lower.

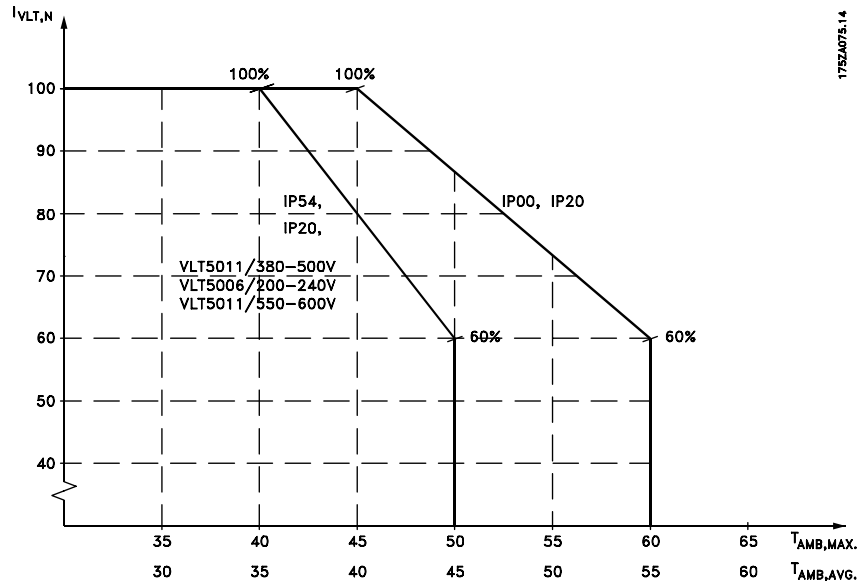

- The current of VLT 5122-5552, 380-500 V and VLT 5042-5352, 525-690 V, is to be derated 1% / °C above 45°C maximum (160% overload) and 40°C maximum (110% overload). Max. temperature is 55° C.
- The current of VLT 5402-5602, 525-690 V, is to be derated 1.5% / °C above 45°C maximum (160% overload) and 40°C maximum (110% overload). Max. temperature is 55° C.

Derating for Air Pressure

Below 1000 m altitude no derating is necessary.

Above 1000 m the ambient temperature (T_{AMB}) or max. output current ($I_{VLT,MAX}$) must be derated in accordance with the diagram below:

1. Derating of output current versus altitude at $T_{AMB} = \text{max. } 45^\circ\text{C}$
2. Derating of max. T_{AMB} versus altitude at 100% output current.

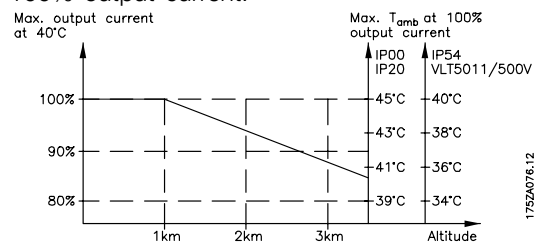

■ Derating for Running at Low Speed

When a motor is connected to a frequency converter, it is necessary to check whether the cooling of the motor is adequate.

At low RPM values, the motor fan is not able to supply the required volume of air for cooling. This problem occurs when the load torque is constant (e.g. a conveyor belt) across the regulating range. The reduced ventilation available decides the size of the torque that can be permitted under a continuous load. If the motor is to run continuously at an RPM value lower than half the rated value, the motor must be supplied with additional air for cooling.

Instead of such extra cooling, the load level of the motor can be reduced. This can be done by choosing a bigger motor. However, the design of

the frequency converter sets limits as to the size of motor that can be connected to it.

■ Derating for Installing Long Motor Cables or Cables with Larger Cross-section

The frequency converter has been tested using 300 m unscreened cable and 150 m screened cable.

The frequency converter has been designed to work using a motor cable with a rated cross-section. If a cable with a larger cross-section is to be used, it is recommended to reduce the output current by 5% for every step the cross-section is increased. (Increased cable cross-section leads to increased capacity to earth, and thus an increased earth leakage current).

■ Derating for high switching frequency

A higher switching frequency (to be set in parameter 411) leads to higher losses in the electronics of the frequency converter.

If *SFAVM* has been selected in parameter 446, the frequency converter will automatically derate the rated output current $I_{VLT,N}$ when the switching frequency exceeds 3.0 kHz.

If *60°AVM* is selected, the frequency converter will automatically derate when the switching frequency exceeds 4.5 kHz. In both cases, the reduction is carried out linearly, down to 60% of $I_{VLT,N}$. The table gives the min., max. and factory-set switching frequencies for frequency converter. The switching pattern can be changed in parameter 446 and the switching frequency in parameter 411.

	SFAVM			60 deg. AVM		
	Min. [kHz]	Max. [kHz]	Fac. [kHz]	Min. [kHz]	Max. [kHz]	Fac. [kHz]
VLT 5001-5006, 200 V	3.0	5.0	3.0	3.0	10.0	4.5
VLT 5008-5027, 200 V	3.0	10.0	3.0	3.0	14.0	4.5
VLT 5032-5052, 200 V	3.0	4.5	3.0	3.0	4.5	4.5
VLT 5001-5011, 500 V	3.0	5.0	3.0	3.0	10.0	4.5
VLT 5016-5052, 500 V	3.0	10.0	3.0	3.0	14.0	4.5
VLT 5062-5102, 500 V	3.0	4.5	3.0	3.0	4.5	4.5
VLT 5122-5302, 500 V	3.0	3.0	3.0	3.0	4.5	4.5
VLT 5352-5552, 500 V	1.5	2.0	2.0	1.5	3.0	3.0
VLT 5001-5011, 600 V	3.0	5.0	3.0	4.5	7.0	4.5
VLT 5016-5027, 600 V	3.0	10.0	3.0	3.0	14.0	4.5
VLT 5032-5052, 600 V	3.0	7.0	3.0	3.0	10.0	4.5
VLT 5062, 600 V	3.0	4.5	3.0	3.0	4.5	4.5
VLT 5042-5302, 690 V	1.5	2.0	2.0	1.5	3.0	3.0
VLT 5352-5602, 690 V	1.5	1.5	1.5	1.5	2.0	2.0

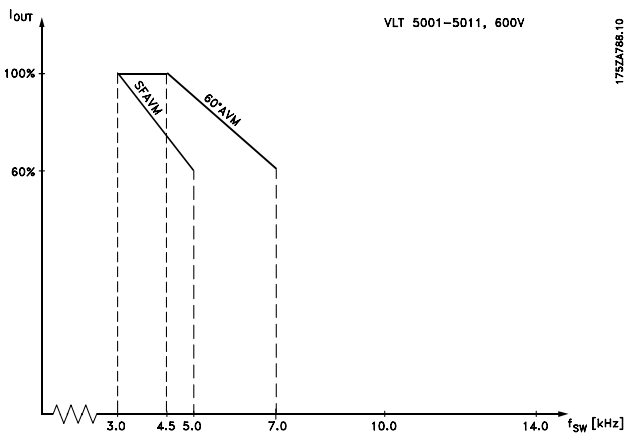
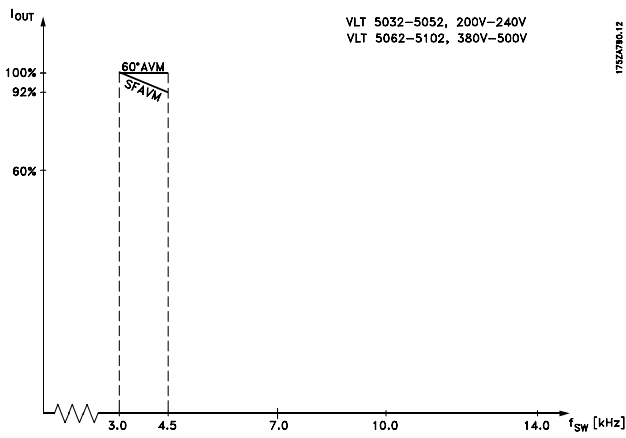
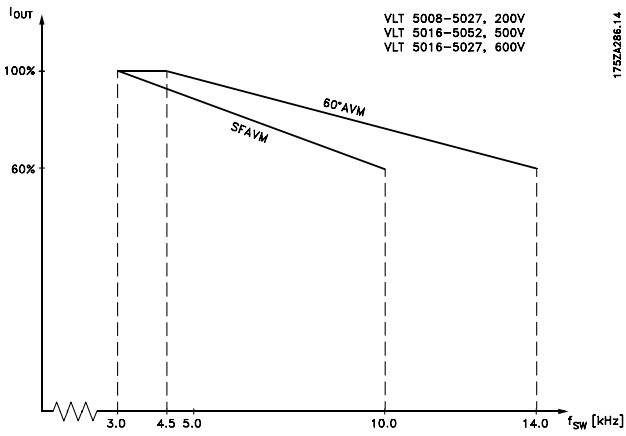
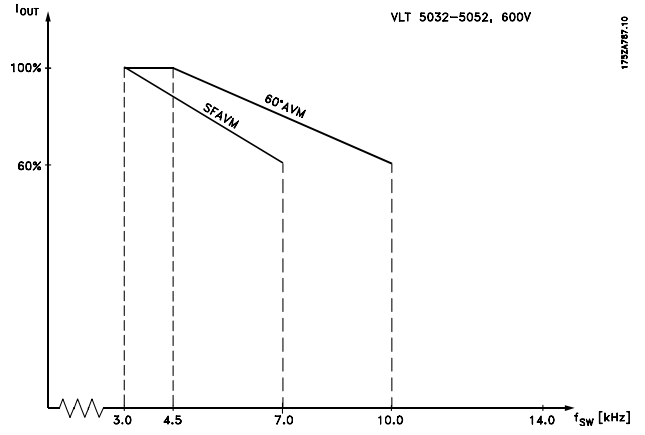
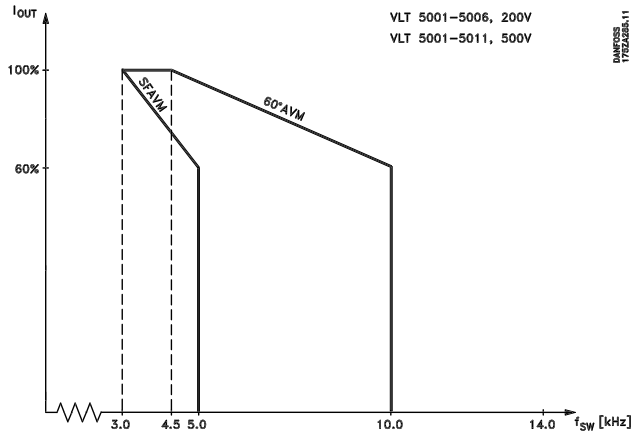

■ Motor thermal protection

The motor temperature is calculated on the basis of motor current, output frequency and time. See parameter 128 in the Operating Instructions.

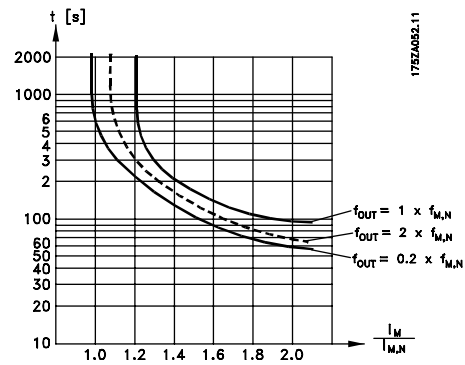

■ Vibration and Shock

The frequency converter has been tested according to a procedure based on the following standards:

- IEC 68-2-6: Vibration (sinusoidal) - 1970
- IEC 68-2-34: Random vibration broad-band - general requirements
- IEC 68-2-35: Random vibration broad-band - high reproducibility
- IEC 68-2-36: Random vibration broad-band - medium reproducibility

The frequency converter complies with requirements that correspond to conditions when the unit is mounted on the walls and floors of production premises, as well as in panels bolted to walls or floors.

Special conditions

■ Air Humidity

The frequency converter has been designed to meet the IEC 68-2-3 standard, EN 50178 pkt. 9.4.2.2/DIN 40040, class E, at 40°C.

■ Aggressive environments

In common with all electronic equipment, a frequency converter contains a large number of mechanical and electronic components, all of which are vulnerable to environmental effects to some extent.



The frequency converter should not therefore be installed in environments with airborne liquids, particles or gases capable of affecting and damaging the electronic components. Failure to take the necessary protective measures increases the risk of stoppages, thus reducing the life of the frequency converter.

Liquids can be carried through the air and condense in the frequency converter. In addition to this, liquids may cause corrosion of components and metal parts. Steam, oil and salt water may cause corrosion of components and metal parts. In such environments, equipment with enclosure rating IP 54 is recommended. As an extra protection, coated printed circuit boards can be ordered as an option.

Airborne Particles such as dust particles may cause mechanical, electrical or thermal failure in the frequency converter. A typical indicator of excessive levels of airborne particles is dust particles around the frequency converter fan. In very dusty environments, equipment with enclosure rating IP 54 or a cabinet for IP 00/IP 20/Nema 1 equipment is recommended.

In environments with high temperatures and humidity, corrosive gases such as sulphur, nitrogen and chlorine compounds will cause chemical processes on the frequency converter components.

Such chemical reactions will rapidly affect and damage the electronic components. In such environments, it is recommended that equipment is mounted in a cabinet with fresh air ventilation, keeping aggressive gases away from the frequency converter. An extra protection in such areas a conformal coating of the printed circuit boards can be ordered as an option.



NB!:

Mounting frequency converters in aggressive environments will increase the risk of stoppages and furthermore considerably reduce the life of the converter.

Before the installation of the frequency converter, the ambient air should be checked for liquids, particles and gases. This may be done by observing existing installations in this environment. Typical indicators of harmful airborne liquids are water or oil on metal parts, or corrosion of metal parts.

Excessive dust particle levels are often found on installation cabinets and existing electrical installations. One indicator of aggressive airborne gases is blackening of copper rails and cable ends on existing installations.

See also Instruction MN.90.IX.YY

■ Efficiency

To reduce energy consumption it is very important to optimize the efficiency of a system. The efficiency of each single element in the system should be as high as possible.

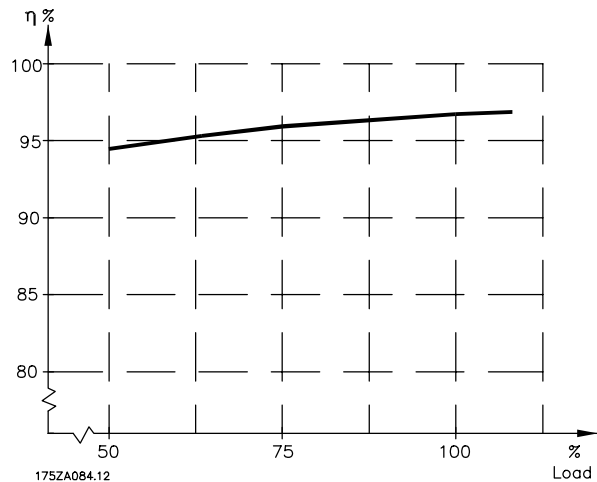

Efficiency of VLT 5000 Series (η_{VLT})

The load on the frequency converter has little effect on its efficiency. In general, the efficiency is the same at the rated motor frequency $f_{M,N}$, regardless of whether the motor supplies 100% of the rated shaft torque or only 75%, i.e. in case of part loads.

This also means that the efficiency of the frequency converter does not change even if other U/f characteristics are chosen.

However, the U/f characteristics influence the efficiency of the motor.

The efficiency declines a little when the switching frequency is set to a value of above 4 kHz (3 kHz for VLT 5005) (parameter 411). The rate of efficiency will also be slightly reduced if the mains voltage is 500 V, or if the motor cable is longer than 30 m.

Efficiency of the motor (η_{MOTOR})

The efficiency of a motor connected to the frequency converter depends on the sine shape of the current. In general, the efficiency is just as good as with mains operation. The efficiency of the motor depends on the type of motor.

In the range of 75-100% of the rated torque, the efficiency of the motor is practically constant, both when it is controlled by the frequency converter and when it runs directly on mains.

In small motors, the influence from the U/f characteristic on efficiency is marginal; however, in motors from 11 kW and up, the advantages are significant.

In general, the switching frequency does not affect the efficiency of small motors. Motors from 11 kW and up have their efficiency improved (1-2%). This is because the sine shape of the motor current is almost perfect at high switching frequency.

Efficiency of the system (η_{SYSTEM})

To calculate the system efficiency, the efficiency of VLT 5000 Series (η_{VLT}) is multiplied by the efficiency of the motor (η_{MOTOR}):

$$\eta_{SYSTEM} = \eta_{VLT} \times \eta_{MOTOR}$$

Based on the graph on this page, it is possible to calculate the efficiency of the system at different loads.

■ Mains Supply Interference/Harmonics

A frequency converter takes up a non-sinusoidal current from mains, which increases the input current I_{RMS} . A non-sinusoidal current can be transformed by means of a Fourier analysis and split up into sine wave currents with different frequencies, i.e. different harmonic currents I_N with 50 Hz as the basic frequency:

Harmonic currents	I_1	I_5	I_7
Hz	50 Hz	250 Hz	350 Hz

The harmonics do not affect the power consumption directly, but increase the heat losses in the installation (transformer, cables). Consequently, in plants with a rather high percentage of rectifier load, it is important to maintain harmonic currents at a low level to avoid overload of the transformer and high temperature in the cables.

Some of the harmonic currents might disturb communication equipment connected to the same transformer or cause resonance in connection with power-factor correction batteries.

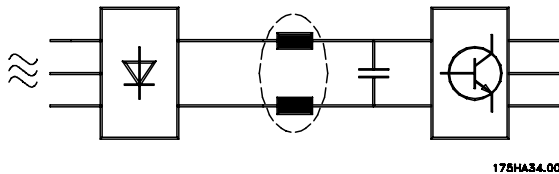

Harmonic currents compared to the RMS input current:

	Input current
I_{RMS}	1.0
I_1	0.9
I_5	0.4
I_7	0.2
I_{11-49}	< 0.1

To ensure low, harmonic currents, the frequency converter has intermediate circuit coils as standard. This normally reduces the input current I_{RMS} by 40%.

The voltage distortion on the mains supply depends on the size of the harmonic currents multiplied by the mains impedance for the frequency in question. The total voltage distortion THD is calculated on the basis of the individual voltage harmonics using the following formula:

$$THD\% = \sqrt{U_5^2 + U_7^2 + \dots + U_N^2} \quad (U_N \text{ \% of } U)$$

See also Application Note MN.90.FX.02.

■ Power Factor

The power factor is the relation between I_1 and I_{RMS} .

The power factor for 3-phase control:

$$\begin{aligned} \text{Power factor} &= \frac{\sqrt{3} \times U \times I_1 \times \cos \varphi_1}{\sqrt{3} \times U \times I_{RMS}} \\ &= \frac{I_1 \times \cos \varphi_1}{I_{RMS}} = \frac{I_1}{I_{RMS}} \text{ since } \cos \varphi_1 = 1 \end{aligned}$$

The power factor indicates the extent to which the frequency converter imposes a load on the mains supply.

The lower the power factor, the higher the I_{RMS} for the same kW performance.

In addition, a high power factor indicates that the different harmonic currents are low.

$$I_{RMS} = \sqrt{I_1^2 + I_5^2 + I_7^2 + \dots + I_n^2}$$

■ CE labelling

What is CE labelling?

The purpose of CE labelling is to avoid technical obstacles to trade within EFTA and the EU. The EU has introduced the CE label as a simple way of showing whether a product complies with the relevant EU directives. The CE label says nothing about the specifications or quality of the product. Frequency converters are regulated by three EU directives:

The machinery directive (98/37/EEC)

All machines with critical moving parts are covered by the machinery directive, which came into force on 1 January 1995. Since a frequency converter is largely electrical, it does not fall under the machinery directive. However, if a frequency converter is supplied for use in a machine, we provide information on safety aspects relating to the frequency converter. We do this by means of a manufacturer's declaration.

The low-voltage directive (73/23/EEC)

Frequency converters must be CE labelled in accordance with the low-voltage directive, which came into force on 1 January 1997. The directive applies to all electrical equipment and appliances used in the 50 - 1000 Volt AC and the 75 - 1500 Volt DC voltage ranges. Danfoss CE labels in accordance with the directive and issues a declaration of conformity upon request.

The EMC directive (89/336/EEC)

EMC is short for electromagnetic compatibility. The presence of electromagnetic compatibility means that the mutual interference between different components/appliances is so small that the functioning of the appliances is not affected.

The EMC directive came into force on 1 January 1996. Danfoss CE labels in accordance with the directive and issues a declaration of conformity upon request. In order that EMC-correct installation can be carried out, this manual gives detailed instructions for installation. In addition, we specify the standards which our different products comply with. We offer the filters that can be seen from the specifications and provide other types of assistance to ensure the optimum EMC result.

In the great majority of cases, the frequency converter is used by professionals of the trade as a complex component forming part of a larger appliance, system or installation. It must be noted that the responsibility for the final EMC properties of the appliance, system or installation rests with the installer.

of using a frequency converter. For each of these situations, explanations are offered as to whether the situation in question is covered by the EMC directive and must be CE labelled.

1. The frequency converter is sold directly to the end-consumer. The frequency converter is for example sold to a DIY market. The end-consumer is a layman. He installs the frequency converter himself for use with a hobby machine, a kitchen appliance, etc. For such applications, the VLT frequency converter must be CE labelled in accordance with the EMC directive.
2. The frequency converter is sold for installation in a plant. The plant is built up by professionals of the trade. It could be a production plant or a heating/ventilation plant designed and installed by professionals of the trade. Neither the frequency converter nor the finished plant has to be CE labelled under the EMC directive. However, the unit must comply with the basic EMC requirements of the directive. The installer can ensure this by using components, appliances and systems that are CE labelled under the EMC directive.
3. The frequency converter is sold as part of a complete system. The system is being marketed as complete. It could be e.g. an air-conditioning system. The complete system must be CE labelled in accordance with the EMC directive. The manufacturer who supplies the system can ensure CE labelling under the EMC directive either by using CE labelled components or by testing the EMC of the system. If he chooses to use only CE labelled components, he does not have to test the entire system.

■ Danfoss VLT frequency converter and CE labelling

CE labelling is a positive feature when used for its original purpose, i.e. to facilitate trade within the EU and EFTA.

However, CE labelling may cover many different specifications. This means that it has to be checked what a given CE label specifically covers.

The specifications covered can in fact be widely different. That is why a CE label can give the installer a false feeling of security when using a frequency converter as a component in a system or an appliance.

We CE label our VLT frequency converters in accordance with the low-voltage directive. This means that as long as the VLT frequency converter is installed correctly, we guarantee that it complies with the low-voltage directive. We issue a declaration

■ What is covered

The EU "Guidelines on the Application of Council Directive 89/336/EEC" outline three typical situations

of conformity that confirms our CE labelling in accordance with the low-voltage directive.

The CE label also applies to the EMC directive, on condition that the instructions given in the Operating Instructions for EMC-correct installation and filtering have been followed. On this basis, a declaration of conformity in accordance with the EMC directive is issued.

The Operating Instructions give detailed instructions for installation to ensure that your installation is EMC-correct. Furthermore, we specify which norms that are complied with by our different products.

We offer the filters that can be seen from the specifications and gladly provide other types of assistance that can help you obtain the best EMC result.

■ **Compliance with EMC directive 89/336/EEC**

In the great majority of cases, the VLT frequency converter is used by professionals of the trade as a complex component forming part of a larger appliance, system or installation. It must be noted that the responsibility for the final EMC properties of the appliance, system or installation rests with the installer. As an aid to the installer, Danfoss has prepared EMC installation guidelines for the Power Drive System. The standards and test levels stated for Power Drive Systems are complied with, provided the right EMC-correct instructions for installation have been followed, see electrical installation.

General aspects of EMC emissions

Electrical interference at frequencies in the range 150 kHz to 30 MHz are usually conducted. Airborne interference from the drive system in the range 30 MHz to 1 GHz is generated from the inverter, the motor cable and the motor.

As the sketch below shows, capacitive currents in the motor cable together with a high dV/dt from the motor voltage generate leakage currents.

The use of a screened motor cable increases the leakage current (see figure below). This is because screened cables have higher capacitance to earth than unscreened cables. If the leakage current is not filtered, it will cause greater interference on the mains in the radio frequency range below approx. 5 MHz. Since the leakage current (I_1) is carried back to the unit through the screen (I_3), there will in principle only be a small electro-magnetic field (I_4) from the screened motor cable according to the below figure.

The screen reduces the radiated interference, but increases the low-frequency interference on the mains. The motor cable screen must be connected to the VLT enclosure as well as on the motor enclosure.

The best way of doing this is by using integrated screen clamps so as to avoid twisted screen ends (pigtailed). These increase the screen impedance at higher frequencies, which reduces the screen effect and increases the leakage current (I_4).

If a screened cable is used for Profibus, standard bus, relay, control cable, signal interface and brake, the screen must be mounted on the enclosure at both ends. In some situations, however, it will be necessary to break the screen to avoid current loops.

Special conditions

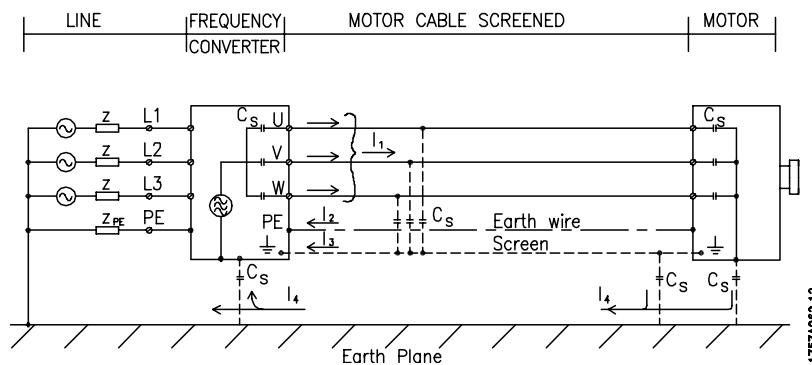

In the cases when the screen is to be placed on a mounting plate for the VLT frequency converter, the mounting plate must be made of metal, because the screen currents are to be conveyed back to the unit. It is also important to ensure good electrical contact from the mounting plate through the mounting screws to the VLT frequency converter chassis. With respect to installation, it is generally less complicated to use unscreened cables than screened ones.

In order to reduce the interference level from the system overall (unit + installation) as far as possible, it is important to make motor and brake cables as short as possible. Cables with a sensitive signal level must not be alongside motor and brake cables. Radio interference higher than 50 MHz (airborne) will be generated especially by the control electronics.



NB!:

Please note, however, that when unscreened cables are used, some emission requirements are not complied with, although the immunity requirements are complied with.

EMC Test Results (Emission, Immunity)

The following test results have been obtained using a system with a VLT frequency converter (with options if relevant), a screened control cable, a control box with potentiometer, as well as a motor and motor cable.

Setup	Emission					
	Environment	Industrial environment		Housing, trades and light industries		
VLT 5001-5011/380-500V VLT 5001-5006/200-240 V	Basic standard	EN 55011 Class A1		EN 55011 Class B1		
Motor cable	Conducted	Radiated	Conducted	Radiated		
	150 kHz-30 MHz	30 MHz-1 GHz	150 kHz-30 MHz	30 MHz-1 GHz		
VLT 5000 with RFI filter option	300 m unscreened/unarmoured	No	No	No	No	
	50 m br. screened/armoured (Bookstyle 20m)	Yes	Yes ²⁾	Yes ²⁾	No	
	150m br. screened/armoured	Yes ¹⁾	Yes ¹⁾	No	No	
	300 m unscreened/unarmoured	Yes	No	No	No	
	50 m br. screened/armoured	Yes	Yes	Yes ²⁾	No	
	150m br. screened/armoured	Yes	Yes	No	No	

1) For VLT 5011/380-500 V and VLT 5006/200-240 V this is only complied with if a maximum braided screened/armoured cable of 100 m is used.

2) Does not apply to 5011/380-500 V and 5006/200-240 V

3) Depending on installation conditions

Setup	Emission					
	Environment	Industrial environment		Housing, trades and light industries		
VLT 5016-5552/380-500 V VLT 5008-5052/200-240 V VLT 5042-5602/525-690 V	Basic standard	EN 55011 Class A1		EN 55011 Class B		
Motor cable	Conducted	Radiated	Conducted	Radiated		
	150 kHz-30 MHz	30 MHz-1 GHz	150 kHz-30 MHz	30 MHz-1 GHz		
VLT 5000 without RFI filter option ^{4) 5)}	300 unscreened/unarmoured	No	No	No	No	
	150 m br. screened/armoured	No	Yes ⁶⁾	No	No	
	300 m unscreened/unarmoured	Yes ^{2) 6)}	No	No	No	
	50 m br. screened/armoured	Yes	Yes ⁶⁾	Yes ^{1) 3) 6)}	No	
VLT 5000 with RFI filter option	150 m br. screened/armoured	Yes ⁶⁾	Yes ⁶⁾	No	No	

1) Does not apply to VLT 5122-5552 / 380-500 V.

2) Depending on installation conditions.

3) VLT 5032-5052 / 200-240 V with external filter.

4) VLT 5122-5552, 380-500 V, fulfils class A-2 at 50 m screened cable without RFI filter (typecode R0).

5) VLT 5042-5352, 525-690 V, fulfils class A2 at 150 m screened cable without RFI filter (R0), and class A1 at 30 m screened cable with RFI filter (R1).

VLT 5402-5602, 525-690 V, fulfils A2 at 150 m screened cable without RFI filter (R0)

6) Does not apply to VLT 5042-5602, 525-690 V.

In order to minimise the conducted noise to the mains supply and the radiated noise from the frequency converter system, the motor cables should be as short as possible and the screen ends should be made in accordance with the section on electrical installation.

■ **Required compliance levels**

Standard / environment	First environment Housing, trades and light industries		Second environment Industrial environment	
	Conducted	Radiated	Conducted	Radiated
EN 61000-6-3	Class B	Class B		
EN 61000-6-4			Class A-1	Class A-1
EN 61800-3 (restricted)	Class A-1	Class A-1	Class A-2	Class A-2
EN 61800-3 (unrestricted)	Class B	Class B	Class A-1	Class A-1

EN 55011: Threshold values and measuring methods for radio interference from industrial, scientific and medical (ISM) high-frequency equipment.

Class A-1: Equipment used in a industrial environment. Unrestricted distribution.

Class A-2: Equipment used in an industrial environment. Restricted distribution.

Class B: Equipment used in areas with a public supply network (dwellings, commerce and light industries). Unrestricted distribution.

Special conditions

■ **EMC Immunity**

In order to document immunity against electrical interference from electrical phenomena, the following immunity tests have been made on a system consisting of a frequency converter (with options, if relevant), a screened control cable and a control box with potentiometer, motor cable, and motor.

The tests were performed in accordance with the following basic standards:

- **EN 61000-4-2 (IEC 61000-4-2): Electrostatic discharges (ESD)**
Simulation of electrostatic discharges from human beings.
- **EN 61000-4-3 (IEC 61000-4-3): Incoming electromagnetic field radiation, amplitude modulated**
Simulation of the effects of radar and radio communication equipment as well as mobile communications.
- **EN 61000-4-4 (IEC 61000-4-4): Burst transients**
Simulation of interference brought about by switching with a contactor, relays or similar devices.
- **EN 61000-4-5 (IEC 61000-4-5): Surge transients**
Simulation of transients brought e.g. by lightning that strikes near installations.

- **VDE 0160 class W2 test pulse: Mains transients**

Simulation of high-energy transients brought about by main fuse breakage, switching of power factor correction capacitors, etc.

- **EN 61000-4-6 (IEC 61000-4-6): RF Common mode**

Simulation of the effect from radio-transmitting equipment connected to connection cables.

See following EMC immunity form.

Immunity continued

Basic standard	Burst IEC 61000-4-4	Surge IEC 61000-4-5	ESD IEC 61000-4-2	Radiated electromagnetic field IEC 61000-4-3	Mains distortion VDE 0160	RF common mode voltage IEC 61000-4-6
Acceptance criterion	B	B	B	A		A
Port connection	CM	DM	CM	—	CM	CM
Line	OK	OK	—	—	OK	OK
Motor	OK	—	—	—	—	OK
Control lines	OK	—	—	—	—	OK
Application and Fieldbus options	OK	—	—	—	—	OK
Signal interface <3 m	OK	—	—	—	—	—
Enclosure	—	—	—	OK	—	OK
Load sharing	OK	—	—	—	—	OK
Standard bus	OK	—	—	—	—	OK
Brake	OK	—	—	—	—	OK
External 24 V DC	OK	—	—	—	—	OK

DM: Differential mode

CM: Common mode

CCC: Capacitive clamp coupling

DCN: Direct coupling network

Immunity continued

Basic specifications	Burst IEC 61000-4-4	Surge IEC 61000-4-5	ESD IEC 61000-4-2	Radiated electromagnetic field IEC 61000-4-3	Mains distortion VDE 0160	RF common mode voltage IEC 61000-4-6
Line	4kV/5 kHz/DCN	2 kV/2 Ω 4 kV/12 Ω	—	—	2,3 x U _N ²	10 V _{RMS}
Motor	4kV/5 kHz/CCC	—	—	—	—	10 V _{RMS}
Control lines	2kV/5 kHz/CCC	— 2 kV/2 Ω ¹⁾	—	—	—	10 V _{RMS}
Application and Fieldbus options	2kV/5 kHz/CCC	— 2 kV/2 Ω ¹⁾	—	—	—	10 V _{RMS}
Signal interface <3 m	1kV/5 kHz/CCC	—	—	—	—	10 V _{RMS}
Enclosure	—	—	8 kV AD 6 kV CD	10 V/m	—	—
Load sharing	4kV/5 kHz/CCC	—	—	—	—	10 V _{RMS}
Standard bus	2kV/5 kHz/CCC	— 4 kV/2 Ω ¹⁾	—	—	—	10 V _{RMS}
Brake	4kV/5 kHz/CCC	—	—	—	—	10 V _{RMS}
External 24 V DC	2kV/5 kHz/CCC	— 4 kV/2 Ω ¹⁾	—	—	—	10 V _{RMS}

DM: Differential mode

CM: Common mode

CCC: Capacitive clamp coupling

DCN: Direct coupling network

1. Injection on cable shield.

 2. 2,3 x U_N: max. test pulse 380 V_{AC}: Class 2/1250 V_{PEAK}, 415 V_{AC}: Class 1/1350 V_{PEAK}

■ Definitions

VLT:

$I_{VLT,MAX}$

The maximum output current.

$I_{VLT,N}$

The rated output current supplied by the frequency converter.

$U_{VLT,MAX}$

The maximum output voltage.

Output:

I_M

The current transmitted to the motor.

U_M

The voltage transmitted to the motor.

f_M

The frequency transmitted to the motor.

f_{JOG}

The frequency transmitted to the motor when the jog function is activated (via digital terminals or the keypad).

f_{MIN}

The minimum frequency transmitted to the motor.

f_{MAX}

The maximum frequency transmitted to the motor.

Break-away torque:

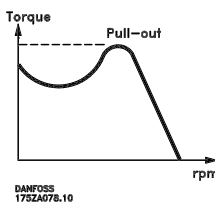

η_{VLT}

The efficiency of the frequency converter is defined as the ratio between the torque power output and the power input.

Input:

Control command:

By means of LCP and the digital inputs, it is possible to start and stop the connected motor.

Functions are divided into two groups, with the following priorities:

Group 1	Reset, Coasting stop, Reset and Coasting stop, Quick-stop, DC braking, Stop and the "Stop" key.
Group 2	Start, Pulse start, Reversing, Start reversing, Jog and Freeze output

Group 1 functions are called Start-disable commands. The difference between group 1 and group 2 is that in group 1 all stop signals must be cancelled for the motor to start. The motor can then be started by means of a single start signal in group 2.

A stop command given as a group 1 command results in the display indication STOP.

A missing stop command given as a group 2 command results in the display indication STAND BY.

Start-disable command:

A stop command that belongs to group 1 of the control commands - see this group.

Stop command:

See Control commands.

Motor:

$I_{M,N}$

The rated motor current (nameplate data).

$f_{M,N}$

The rated motor frequency (nameplate data).

$U_{M,N}$

The rated motor voltage (nameplate data).

$P_{M,N}$

The rated power delivered by the motor (nameplate data).

$n_{M,N}$

The rated motor speed (nameplate data).

$T_{M,N}$

The rated torque (motor).

References:

preset ref.

A firmly defined reference which can be set from -100% to +100% of the reference range. There are four preset references, which can be selected via the digital terminals.

analogue ref.

A signal transmitted to input 53, 54 or 60. Can be voltage or current.

pulse ref.

A signal transmitted to the digital inputs (terminal 17 or 29).

binary ref.

A signal transmitted to the serial communication port.

Ref_{MIN}

The smallest value which the reference signal may have. Set in parameter 204.

Ref_{MAX}

The maximum value which the reference signal may have. Set in parameter 205.

Miscellaneous:

ELCB:

Earth Leakage Circuit Breaker.

lsb:

Least significant bit.

Used in serial communication.

msb

Most significant bit.

Used in serial communication.

PID:

The PID regulator maintains the desired speed (pressure, temperature, etc.) by adjusting the output frequency to match the varying load.

Trip:

A state which occurs in different situations, e.g. if the frequency converter is subjected to an overtemperature. A trip can be cancelled by pressing reset or, in some cases, automatically.

Trip locked:

A state which occurs in different situations, e.g. if the frequency converter is subject to an overtemperature. A locked trip can be cancelled by cutting off mains and restarting the frequency converter.

Initialising:

If initialising is carried out, the frequency converter returns to the factory setting.

Setup:

There are four Setups, in which it is possible to save parameter settings. It is possible to change between the four parameter Setups and to edit one Setup, while another Setup is active.

LCP:

The control panel, which makes up a complete interface for control and programming of VLT 5000 Series. The control panel is detachable and may, as an alternative, be installed up to 3 metres away from the frequency converter, i.e. in a front panel, by means of the installation kit option.

VVC^{plus}

If compared with standard voltage/frequency ratio control, VVC^{plus} improves the dynamics and the stability, both when the speed reference is changed and in relation to the load torque.

Slip compensation:

Normally, the motor speed will be affected by the load, but this load dependence is unwanted. The frequency converter compensates for the slip by giving the frequency a supplement that follows the measured effective current.

Thermistor:

A temperature-dependent resistor placed where the temperature is to be monitored (frequency converter or motor).

Analogue inputs:

The analogue inputs can be used for controlling various functions of the frequency converter.

There are two types of analogue inputs:

Current input, 0-20 mA

Voltage input, 0-10 V DC.

Analogue outputs:

There are two analogue outputs, which are able to supply a signal of 0-20 mA, 4-20 mA or a digital signal.

Digital inputs:

The digital inputs can be used for controlling various functions of the frequency converter.

Digital outputs:

There are four digital outputs, two of which activate a relay switch. The outputs are able to supply a 24 V DC (max. 40 mA) signal.

Brake resistor:

The brake resistor is a module capable of absorbing the brake power that is generated in regenerative braking. This regenerative braking power increases the intermediate circuit voltage and a brake chopper ensures that the power is transmitted to the brake resistor.

Pulse encoder:

An external, digital pulse transmitter used for feeding back information on motor speed. The encoder is used in applications where great accuracy in speed control is required.

AWG:

Means American Wire Gauge, i.e. the American measuring unit for cable cross-section.

Manual initialisation:

Press the [CHANGE DATA] + [MENU] + [OK] keys at the same time to carry out manual initialisation.

60° AVM

Switching pattern called 60° A synchronous Vector Modulation.

SFAVM

Switching pattern called Stator Flux oriented A synchronous Vector Modulation.

Automatic motor adjustment, AMA:

Automatic motor adjustment algorithm, which determines the electrical parameters for the connected motor, at standstill.

On-line/off-line parameters:

On-line parameters are activated immediately after the data value is changed. Off-line parameters are not activated until OK has been entered on the control unit.

VT characteristics:

Variable torque characteristics, used for pumps and fans.

CT characteristics:

Constant torque characteristics, used for all applications, such as conveyor belts and cranes. CT characteristics are not used for pumps and fans.

MCM:

Stands for Mille Circular Mil, an American measuring unit for cable cross-section. 1 MCM \equiv 0.5067 mm².

■ Factory Settings

PNU #	Parameter description	Factory setting	Range	Changes during operation	4-Setup	Conversion index	Data type
001	Language	English		Yes	No	0	5
002	Local/remote control	Remote control		Yes	Yes	0	5
003	Local reference	000.000		Yes	Yes	-3	4
004	Active setup	Setup 1		Yes	No	0	5
005	Programming setup	Active setup		Yes	No	0	5
006	Copying of setups	No copying		No	No	0	5
007	LCP copy	No copying		No	No	0	5
008	Display scaling of motor frequency	1	0.01 - 500.00	Yes	Yes	-2	6
009	Display line 2	Frequency [Hz]		Yes	Yes	0	5
010	Display line 1.1	Reference [%]		Yes	Yes	0	5
011	Display line 1.2	Motor current [A]		Yes	Yes	0	5
012	Display line 1.3	Power [kW]		Yes	Yes	0	5
013	Local control/configura	LCP digital control/as par.100		Yes	Yes	0	5
014	Local stop	Possible		Yes	Yes	0	5
015	Local jog	Not possible		Yes	Yes	0	5
016	Local reversing	Not possible		Yes	Yes	0	5
017	Local reset of trip	Possible		Yes	Yes	0	5
018	Lock for data change	Not locked		Yes	Yes	0	5
019	Operating state at power-up, local control	Forced stop, use saved ref.		Yes	Yes	0	5
027	Warning readout	Warning in line 1/2		Yes	No	0	5

Changes during operation:

"Yes" means that the parameter can be changed, while the frequency converter is in operation. "No" means that the frequency converter must be stopped before a change can be made.

4-Setup:

"Yes" means that the parameter can be programmed individually in each of the four setups, i.e. the same parameter can have four different data values. "No" means that the data value will be the same in all four setups.

Conversion index:

This number refers to a conversion figure to be used when writing or reading by means of a frequency converter.

Conversion index	Conversion factor
74	0.1
2	100
1	10
0	1
-1	0.1
-2	0.01
-3	0.001
-4	0.0001

Data type:

Data type shows the type and length of the telegram.

Data type	Description
3	Integer 16
4	Integer 32
5	Unsigned 8
6	Unsigned 16
7	Unsigned 32
9	Text string

VLT 5000 Design Guide

PNU #	Parameter description	Factory setting	Range	Changes during operation	4-Setup	Conversion index	Data type
100	Configuration	Speed control, open loop		No	Yes	0	5
101	Torque characteristics	High - constant torque		Yes	Yes	0	5
102	Motor power	Depends on the unit	0.18-600 kW	No	Yes	1	6
103	Motor voltage	Depends on the unit	200 - 600 V	No	Yes	0	6
104	Motor frequency	50 Hz / 60 Hz		No	Yes	0	6
105	Motor current	Depends on the unit	0.01- $I_{VLT,MAX}$	No	Yes	-2	7
106	Rated motor speed	Depends on the unit	100-60000 rpm	No	Yes	0	6
107	Automatic motor adaptation, AMA	Adaptation off		No	No	0	5
108	Stator resistor	Depends on the unit		No	Yes	-4	7
109	Stator reactance	Depends on the unit		No	Yes	-2	7
110	Motor magnetizing, 0 rpm	100 %	0 - 300 %	Yes	Yes	0	6
111	Min. frequency normal magnetizing	1.0 Hz	0.1 - 10.0 Hz	Yes	Yes	-1	6
112							
113	Load compensation at low speed	100 %	0 - 300 %	Yes	Yes	0	6
114	Load compensation at high speed	100 %	0 - 300 %	Yes	Yes	0	6
115	Slip compensation	100 %	-500 - 500 %	Yes	Yes	0	3
116	Slip compensation time constant	0.50 s	0.05 - 1.00 s	Yes	Yes	-2	6
117	Resonance dampening	100 %	0 - 500 %	Yes	Yes	0	6
118	Resonance dampening time constant	5 ms	5 - 50 ms	Yes	Yes	-3	6
119	High starting torque	0.0 sec.	0.0 - 0.5 s	Yes	Yes	-1	5
120	Start delay	0.0 sec.	0.0 - 10.0 s	Yes	Yes	-1	5
121	Start function	Coasting in start delay time		Yes	Yes	0	5
122	Function at stop	Coasting		Yes	Yes	0	5
123	Min. frequency for activating function at stop	0.0 Hz	0.0 - 10.0 Hz	Yes	Yes	-1	5
124	DC holding current	50 %	0 - 100 %	Yes	Yes	0	6
125	DC braking current	50 %	0 - 100 %	Yes	Yes	0	6
126	DC braking time	10.0 sec.	0.0 - 60.0 sec.	Yes	Yes	-1	6
127	DC brake cut-in frequency	Off	0.0-par. 202	Yes	Yes	-1	6
128	Motor thermal protection	No protection		Yes	Yes	0	5
129	External motor fan	No		Yes	Yes	0	5
130	Start frequency	0.0 Hz	0.0-10.0 Hz	Yes	Yes	-1	5
131	Initial voltage	0.0 V	0.0-par. 103	Yes	Yes	-1	6
145	Minimum DC brake time	0 sec.	0 - 10 sec.	Yes	Yes	-1	6

PNU #	Parameter description	Factory setting	Range	Changes during operation	4-Setup	Conversion index	Data type
200	Output frequency range/direction	Only clockwise, 0-132 Hz		No	Yes	0	5
201	Output frequency low limit	0.0 Hz	0.0 - f_{MAX}	Yes	Yes	-1	6
202	Output frequency high limit	66 / 132 Hz	f_{MIN} - par. 200	Yes	Yes	-1	6
203	Reference/feedback area	Min - max		Yes	Yes	0	5
204	Minimum reference	0.000	-100,000.000-Ref _{MAX}	Yes	Yes	-3	4
205	Maximum reference	50.000	Ref _{MIN} -100,000.000	Yes	Yes	-3	4
206	Ramp type	Linear		Yes	Yes	0	5
207	Ramp-up time 1	Depends on unit	0.05 - 3600	Yes	Yes	-2	7
208	Ramp-down time 1	Depends on unit	0.05 - 3600	Yes	Yes	-2	7
209	Ramp-up time 2	Depends on unit	0.05 - 3600	Yes	Yes	-2	7
210	Ramp-down time 2	Depends on unit	0.05 - 3600	Yes	Yes	-2	7
211	Jog ramp time	Depends on unit	0.05 - 3600	Yes	Yes	-2	7
212	Quick stop ramp-down time	Depends on unit	0.05 - 3600	Yes	Yes	-2	7
213	Jog frequency	10.0 Hz	0.0 - par. 202	Yes	Yes	-1	6
214	Reference function	Sum		Yes	Yes	0	5
215	Preset reference 1	0.00 %	- 100.00 - 100.00 %	Yes	Yes	-2	3
216	Preset reference 2	0.00 %	- 100.00 - 100.00 %	Yes	Yes	-2	3
217	Preset reference 3	0.00 %	- 100.00 - 100.00 %	Yes	Yes	-2	3
218	Preset reference 4	0.00 %	- 100.00 - 100.00 %	Yes	Yes	-2	3
219	Catch up/slow down value	0.00 %	0.00 - 100 %	Yes	Yes	-2	6
220							
221	Torque limit for motor mode	160 %	0.0 % - xxx %	Yes	Yes	-1	6
222	Torque limit for regenerative operation	160 %	0.0 % - xxx %	Yes	Yes	-1	6
223	Warning: Low current	0.0 A	0.0 - par. 224	Yes	Yes	-1	6
224	Warning: High current	$I_{VLT,MAX}$	Par. 223 - $I_{VLT,MAX}$	Yes	Yes	-1	6
225	Warning: Low frequency	0.0 Hz	0.0 - par. 226	Yes	Yes	-1	6
226	Warning: High frequency	132.0 Hz	Par. 225 - par. 202	Yes	Yes	-1	6
227	Warning: Low feedback	-4000.000	-100,000.000 - par. 228	Yes		-3	4
228	Warning: High feedback	4000.000	Par. 227 - 100,000.000	Yes		-3	4
229	Frequency bypass, bandwidth	OFF	0 - 100 %	Yes	Yes	0	6
230	Frequency bypass 1	0.0 Hz	0.0 - par. 200	Yes	Yes	-1	6
231	Frequency bypass 2	0.0 Hz	0.0 - par. 200	Yes	Yes	-1	6
232	Frequency bypass 3	0.0 Hz	0.0 - par. 200	Yes	Yes	-1	6
233	Frequency bypass 4	0.0 Hz	0.0 - par. 200	Yes	Yes	-1	6
234	Motor phase monitor	Enable		Yes	Yes	0	5

VLT 5000 Design Guide

PNU #	Parameter description	Factory setting	Range	Changes during operation	4-Setup	Conversion index	Data type
300	Terminal 16, input	Reset		Yes	Yes	0	5
301	Terminal 17, input	Freeze reference		Yes	Yes	0	5
302	Terminal 18 Start, input	Start		Yes	Yes	0	5
303	Terminal 19, input	Reversing		Yes	Yes	0	5
304	Terminal 27, input	Coasting stop, inverse		Yes	Yes	0	5
305	Terminal 29, input	Jog		Yes	Yes	0	5
306	Terminal 32, input	Choice of setup, msb/speed up		Yes	Yes	0	5
307	Terminal 33, input	Choice of setup, lsb/speed down		Yes	Yes	0	5
308	Terminal 53, analogue input voltage	Reference		Yes	Yes	0	5
309	Terminal 53, min. scaling	0.0 V	0.0 - 10.0 V	Yes	Yes	-1	5
310	Terminal 53, max. scaling	10.0 V	0.0 - 10.0 V	Yes	Yes	-1	5
311	Terminal 54, analogue input voltage	No operation		Yes	Yes	0	5
312	Terminal 54, min. scaling	0.0 V	0.0 - 10.0 V	Yes	Yes	-1	5
313	Terminal 54, max. scaling	10.0 V	0.0 - 10.0 V	Yes	Yes	-1	5
314	Terminal 60, analogue input current	Reference		Yes	Yes	0	5
315	Terminal 60, min. scaling	0.0 mA	0.0 - 20.0 mA	Yes	Yes	-4	5
316	Terminal 60, max. scaling	20.0 mA	0.0 - 20.0 mA	Yes	Yes	-4	5
317	Time out	10 sec.	1 - 99 sec.	Yes	Yes	0	5
318	Function after time out	Off		Yes	Yes	0	5
319	Terminal 42, output	0 - I _{MAX} P 0-20 mA		Yes	Yes	0	5
320	Terminal 42, output, pulse scaling	5000 Hz	1 - 32000 Hz	Yes	Yes	0	6
321	Terminal 45, output	0 - f _{MAX} P 0-20 mA		Yes	Yes	0	5
322	Terminal 45, output, pulse scaling	5000 Hz	1 - 32000 Hz	Yes	Yes	0	6
323	Relay 01, output	Ready - no thermal warning		Yes	Yes	0	5
324	Relay 01, ON delay	0.00 sec.	0.00 - 600 sec.	Yes	Yes	-2	6
325	Relay 01, OFF delay	0.00 sec.	0.00 - 600 sec.	Yes	Yes	-2	6
326	Relay 04, output	Ready - remote control		Yes	Yes	0	5
327	Pulse reference, max. frequency	5000 Hz		Yes	Yes	0	6
328	Pulse feedback, max. frequency	25000 Hz		Yes	Yes	0	6
329	Encoder feedback pulse/rev.	1024 pulses/rev.	1 - 4096 pulses/rev.	Yes	Yes	0	6
330	Freeze reference/output function	No operation		Yes	No	0	5
345	Encoder loss timeout	1 sec.	0 - 60 sec	Yes	Yes	-1	6
346	Encoder loss function	OFF		Yes	Yes	0	5
357	Terminal 42, Output minimum scaling	0 %	000 - 100%	Yes	Yes	0	6
358	Terminal 42, Output maximum scaling	100%	000 - 500%	Yes	Yes	0	6
359	Terminal 45, Output minimum scaling	0 %	000 - 100%	Yes	Yes	0	6
360	Terminal 45, Output maximum scaling	100%	000 - 500%	Yes	Yes	0	6
361	Encoder loss threshold	300%	000 - 600 %	Yes	Yes	0	6

VLT 5000 Design Guide

PNU #	Parameter description	Factory setting	Range	Changes during operation	4-Setup	Conversion index	Data type
400	Brake function/overvoltage control	Off		Yes	No	0	5
401	Brake resistor, ohm	Depends on the unit		Yes	No	-1	6
402	Brake power limit, kW	Depends on the unit		Yes	No	2	6
403	Power monitoring	On		Yes	No	0	5
404	Brake check	Off		Yes	No	0	5
405	Reset function	Manual reset		Yes	Yes	0	5
406	Automatic restart time	5 sec.	0 - 10 sec.	Yes	Yes	0	5
407	Mains Failure	No function		Yes	Yes	0	5
408	Quick discharge	Not possible		Yes	Yes	0	5
409	Trip delay torque	Off	0 - 60 sec.	Yes	Yes	0	5
410	Trip delay-inverter	Depends on type of unit	0 - 35 sec.	Yes	Yes	0	5
411	Switching frequency	Depends on type of unit	1.5 - 14 kHz	Yes	Yes	2	6
412	Output frequency dependent switching frequency	Not possible		Yes	Yes	0	5
413	Overmodulation function	On		Yes	Yes	-1	5
414	Minimum feedback	0.000	-100,000.000 - FB _{HIGH}	Yes	Yes	-3	4
415	Maximum feedback	1500.000	FB _{LOW} - 100,000.000	Yes	Yes	-3	4
416	Process unit	%		Yes	Yes	0	5
417	Speed PID proportional gain	0.015	0.000 - 0.150	Yes	Yes	-3	6
418	Speed PID integration time	8 ms	2.00 - 999.99 ms	Yes	Yes	-4	7
419	Speed PID differentiation time	30 ms	0.00 - 200.00 ms	Yes	Yes	-4	6
420	Speed PID diff. gain ratio	5.0	5.0 - 50.0	Yes	Yes	-1	6
421	Speed PID low-pass filter	10 ms	5 - 200 ms	Yes	Yes	-4	6
422	U 0 voltage at 0 Hz	20.0 V	0.0 - parameter 103	Yes	Yes	-1	6
423	U 1 voltage	parameter 103	0.0 - U _{VLT, MAX}	Yes	Yes	-1	6
424	F 1 frequency	parameter 104	0.0 - parameter 426	Yes	Yes	-1	6
425	U 2 voltage	parameter 103	0.0 - U _{VLT, MAX}	Yes	Yes	-1	6
426	F 2 frequency	parameter 104	par.424- par.428	Yes	Yes	-1	6
427	U 3 voltage	parameter 103	0.0 - U _{VLT, MAX}	Yes	Yes	-1	6
428	F 3 frequency	parameter 104	par.426 -par.430	Yes	Yes	-1	6
429	U 4 voltage	parameter 103	0.0 - U _{VLT, MAX}	Yes	Yes	-1	6

VLT 5000 Design Guide

PNU #	Parameter description	Factory setting	Range	Changes during operation	4-Setup	Conversion index	Data type
430	F 4 frequency	parameter 104	par.426-par.432	Yes	Yes	-1	6
431	U 5 voltage	parameter 103	.0 - $U_{VLT, MAX}$	Yes	Yes	-1	6
432	F 5 frequency	parameter 104	par.426 - 1000 Hz	Yes	Yes	-1	6
433	Torque proportional gain	100%	0 (Off) - 500%	Yes	Yes	0	6
434	Torque integral time	0.02 sec.	0.002 - 2.000 sec.	Yes	Yes	-3	7
437	Process PID Normal/inverse control	Normal		Yes	Yes	0	5
438	Process PID anti windup	On		Yes	Yes	0	5
439	Process PID start frequency	parameter 201	$f_{min} - f_{max}$	Yes	Yes	-1	6
440	Process PID proportional gain	0.01	0.00 - 10.00	Yes	Yes	-2	6
441	Process PID integral time	9999.99 sec. (OFF)	0.01 - 9999.99 sec.	Yes	Yes	-2	7
442	Process PID differentiation time	0.00 sec. (OFF)	0.00 - 10.00 sec.	Yes	Yes	-2	6
443	Process PID diff. gain limit	5.0	5.0 - 50.0	Yes	Yes	-1	6
444	Process PID lowpass filter time	0.01	0.01 - 10.00	Yes	Yes	-2	6
445	Flying start	Disable		Yes	Yes	0	5
446	Switching pattern	SFAVM		Yes	Yes	0	5
447	Torque compensation	100%	-100 - +100%	Yes	Yes	0	3
448	Gear ratio	1	0.001 - 100.000	No	Yes	-2	4
449	Friction loss	0%	0 - 50%	No	Yes	-2	6
450	Mains voltage at mains fault	Depends on unit	Depends on unit	Yes	Yes	0	6
453	Speed closed loop gear ratio	1	0.01-100	No	Yes	0	4
454	Dead time compensation	On		No	No	0	5
455	Frequency range monitor	Enable				0	5
457	Phase loss function	Trip		Yes	Yes	0	5
483	Dynamic DC Link compensation	On		No	No	0	5

PNU #	Parameter description	Factory setting	Range	Changes during operation	4-Setup	Conversion index	Data type
500	Address	1	0 - 126	Yes	No	0	6
501	Baudrate	9600 Baud		Yes	No	0	5
502	Coasting	Logic or		Yes	Yes	0	5
503	Quick-stop	Logic or		Yes	Yes	0	5
504	DC-brake	Logic or		Yes	Yes	0	5
505	Start	Logic or		Yes	Yes	0	5
506	Reversing	Logic or		Yes	Yes	0	5
507	Selection of setup	Logic or		Yes	Yes	0	5
508	Selection of speed	Logic or		Yes	Yes	0	5
509	Bus jog 1	10.0 Hz	0.0 - parameter 202	Yes	Yes	-1	6
510	Bus jog 2	10.0 Hz	0.0 - parameter 202	Yes	Yes	-1	6
511							
512	Telegram profile	FC Drive		No	Yes	0	5
513	Bus time interval	1 sec.	1 - 99 s	Yes	Yes	0	5
514	Bus time interval function	Off		Yes	Yes	0	5
515	Data read-out: Reference %			No	No	-1	3
516	Data read-out: Reference unit			No	No	-3	4
517	Data read-out: Feedback			No	No	-3	4
518	Data read-out: Frequency			No	No	-1	6
519	Data read-out: Frequency x Scaling			No	No	-2	7
520	Data read-out: Current			No	No	-2	7
521	Data read-out: Torque			No	No	-1	3
522	Data read-out: Power, kW			No	No	1	7
523	Data read-out: Power, HP			No	No	-2	7
524	Data read-out: Motor voltage			No	No	-1	6
525	Data read-out: DC link voltage			No	No	0	6
526	Data read-out: Motor temp.			No	No	0	5
527	Data read-out: VLT temp.			No	No	0	5
528	Data read-out: Digital input			No	No	0	5
529	Data read-out: Terminal 53, analogue input			No	No	-2	3
530	Data read-out: Terminal 54, analogue input			No	No	-2	3
531	Data read-out: Terminal 60, analogue input			No	No	-5	3
532	Data read-out: Pulse reference			No	No	-1	7
533	Data read-out: External reference %			No	No	-1	3
534	Data read-out: Status word, binary			No	No	0	6
535	Data read-out: Brake power/2 min.			No	No	2	6
536	Data read-out: Brake power/sec.			No	No	2	6
537	Data read-out: Heat sink temperature			No	No	0	5
538	Data read-out: Alarm word, binary			No	No	0	7
539	Data read-out: VLT Control word, binary			No	No	0	6
540	Data read-out: Warning word, 1			No	No	0	7
541	Data read-out: Extended Status word			No	No	0	7
553	Display text 1			No	No	0	9
554	Display text 2			No	No	0	9
557	Data read-out: Motor RPM			No	No	0	4
558	Data read-out: Motor RPM x scaling			No	No	-2	4
580	Defined parameter			No	No	0	6
581	Defined parameter			No	No	0	6
582	Defined parameter			No	No	0	6

VLT 5000 Design Guide

PNU #	Parameter description	Factory setting	Range	Changes during operation	4-Setup	Conversion index	Data type
600	Operating data: Operating hours			No	No	74	7
601	Operating data: Hours run			No	No	74	7
602	Operating data: kWh counter			No	No	1	7
603	Operating data: Number of power-up's			No	No	0	6
604	Operating data: Number of overtemperatures			No	No	0	6
605	Operating data: Number of overvoltages			No	No	0	6
606	Data log: Digital input			No	No	0	5
607	Data log: Bus commands			No	No	0	6
608	Data log: Bus Status word			No	No	0	6
609	Data log: Reference			No	No	-1	3
610	Data log: Feedback			No	No	-3	4
611	Data log: Motor frequency			No	No	-1	3
612	Data log: Motor voltage			No	No	-1	6
613	Data log: Motor current			No	No	-2	3
614	Data log: DC link voltage			No	No	0	6
615	Fault log: Error code			No	No	0	5
616	Fault log: Time			No	No	-1	7
617	Fault log: Value			No	No	0	3
618	Reset of kWh counter	No reset		Yes	No	0	5
619	Reset of hours-run counter	No reset		Yes	No	0	5
620	Operating mode Normal function	Normal function		No	No	0	5
621	Nameplate: VLT type			No	No	0	9
622	Nameplate: Power section			No	No	0	9
623	Nameplate: VLT ordering number			No	No	0	9
624	Nameplate: Software version no.			No	No	0	9
625	Nameplate: LCP identification no.			No	No	0	9
626	Nameplate: Database identification no.			No	No	-2	9
627	Nameplate: Power section identification no.			No	No	0	9
628	Nameplate: Application option type			No	No	0	9
629	Nameplate: Application option ordering no.			No	No	0	9
630	Nameplate: Communication option type			No	No	0	9
631	Nameplate: Communication option ordering no.			No	No	0	9

VLT 5000 Design Guide

PNU #	Parameter description	Factory setting	Range	Changes during operation	4-Setup	Conversion index	Data type
700	Relay 6, function	Ready signal		Yes	Yes	0	5
701	Relay 6, ON delay	0 sec.	0.00-600 sec.	Yes	Yes	-2	6
702	Relay 6, OFF delay	0 sec.	0.00-600 sec.	Yes	Yes	-2	6
703	Relay 7, function	Motor running		Yes	Yes	0	5
704	Relay 7, ON delay	0 sec.	0.00-600 sec.	Yes	Yes	-2	6
705	Relay 7, OFF delay	0 sec.	0.00-600 sec.	Yes	Yes	-2	6
706	Relay 8, function	Mains ON		Yes	Yes	0	5
707	Relay 8, ON delay	0 sec.	0.00-600 sec.	Yes	Yes	-2	6
708	Relay 8, OFF delay	0 sec.	0.00-600 sec.	Yes	Yes	-2	6
709	Relay 9, function	Fault		Yes	Yes	0	5
710	Relay 9, ON delay	0 sec.	0.00-600 sec.	Yes	Yes	-2	6
711	Relay 9, OFF delay	0 sec.	0.00-600 sec.	Yes	Yes	-2	6

■ Index
A

Accuracy of display readout (parameters 009-012)	35
Acoustic noise	117
Additional characteristics	102
Additional Text	103
Aggressive environments	122
Air Humidity	121
Application option	23

B

Basic characteristics	99
Brake resistor	34
Brake resistors	18, 27

C

cable clamps	79
control cables	79
Cable clamp	83
Cable lengths	35
CE labelling	125
Connection of motor	65
Control card, 24 V DC supply	34
Control card, analogue inputs	33
Control card, digital inputs:	32
Control card, digital/pulse and analogue outputs	33
Control card, pulse/encoder input	33
Control card, RS 485 serial communication	34
Control characteristics	35
Control Word	92, 95
Conversion and unit of measurement	100
Cooling	62, 63

D

direction of motor rotation	65
Data Character (byte)	89
Default value	102
Definitions	132
Derating for Air Pressure	118
Derating for ambient temperature	118
Derating for high switching frequency	119
Derating for Running at Low Speed	119
DeviceNet	23
DIP Switches 1-4	78
Direction of motor rotation	65

E

Earth leakage current	113
earthing	83

Electrical installation	64, 77
Electrical installation - 24 Volt external DC supply	68
Electrical installation - brake cable	66
Electrical installation - brake resistor temperature switch	66
Electrical installation - bus connection	78
Electrical installation - control cables	76
Electrical installation - earthing of control cables	83
Electrical installation - EMC precautions	79
Electrical installation - external fan supply	68
Electrical installation - mains supply	64
Electrical installation - motor cables	64
Electrical installation - relay outputs	68
Electrical installation, power cables	69
EMC Test Results	128
Equalising cable,	83
External 24 V DC supply	34, 68
Externals	35

F

Factory settings	135
FC Profile	92
FC protocol	92
Fieldbus Profile	95
Fuses	55

G

Galvanic Isolation (PELV)	113
Galvanically isolated	78
General technical data	31
General warning	4

H

Harmonic filter	18
Harmonic filters	29
high torque characteristic	12
High voltage test	64

I

IT mains	84
Interbus	23
Introduction	6

K

Key Diagram	10, 11
-------------------	--------

L

Lower limit	102
LC filter	18, 24
Line reactors	20

Literature 7	Telegram Structure 87
Loadsharing 66	Telegram Traffic 87
LonWorks 23	Terminal cover, 18
 	Tightening-up torques and screw sizes 66
M	Torque characteristics 31
Mains supply 38	Type code ordering number string..... 12
Mains supply (L1, L2, L3): 31	Typecode 16
Mains Supply Interference/Harmonics 124	
MCT 10 19	U
Mechanical dimensions 58	Upper limit 102
Mechanical installation 61	Unintended start 4
Modbus 23	Use of emc-correct cables 82
Motor cables 79	
Motor protection 66	V
Motor thermal protection 66	Vibration and Shock 121
 	VLT 5000 Series protection: 37, 37
N	Vlt output data (u, v, w): 31
Name 102	
normal torque characteristic 12	W
Number of elements 100	Warning against unintended start 4
O	
Output data 31	
P	
Profibus DP-V1 19	
Parallel coupling of motors 65	
PC Software tools 18	
Peak voltage 115	
PLC 83	
Power Factor 124	
Profibus 23	
Protocols 87	
R	
Read parameter description elements 99	
Relay outputs: 34, 34	
RFI switch 84	
Rise time 115	
RS 485 78	
S	
Safety earthing 64	
Safety regulations 4	
serial communication 83	
Status Word 94, 96	
T	