

**■ Contents**

<b>Introduction to HVAC</b> .....	4
Software version .....	4
Safety regulations .....	5
Warning against unintended start .....	5
Introduction to Operating Instructions .....	7
Available literature .....	8
VLT 6000 Advantages in a HVAC installation .....	8
Control principle .....	9
AEO - Automatic Energy Optimization .....	10
Example of application - Speed control of fan in ventilation system .....	11
Example of application - Constant pressure regulation in water supply system .....	12
Fire mode .....	13
CE labelling .....	15
PC software and serial communication .....	15
Unpacking and ordering a VLT frequency converter .....	16
Type code ordering number string .....	16
Ordering form .....	20
<b>Installation</b> .....	21
Mains supply (L1, L2, L3) .....	21
Max. imbalance of supply voltage .....	21
Technical data, mains supply 3 x 200-240V .....	26
Technical data, mains supply 3 x 380-460V .....	28
Technical data, mains supply 3 x 525-600 V .....	33
Fuses .....	38
Mechanical dimensions .....	41
Mechanical installation .....	45
General information about electrical installation .....	48
High voltage warning .....	48
Earthing .....	48
Cables .....	48
Screened/armoured cables .....	48
Extra protection with regard to indirect contact .....	48
RFI switch .....	50
High voltage test .....	53
Heat emission from VLT 6000 HVAC .....	53
Ventilation of integrated VLT 6000 HVAC .....	53
EMC correct electrical installation .....	53
Use of EMC-correct cables .....	55
Electrical installation - earthing of control cables .....	56
Electrical installation, enclosures .....	57
Tightening-up torque and screw sizes .....	64
Mains connection .....	64
Motor connection .....	64
Direction of motor rotation .....	65
Motor cables .....	65
Motor thermal protection .....	66
Earth connection .....	66
Installation of 24 Volt external DC supply .....	66
DC bus connection .....	66
High-voltage relay .....	66

Control card .....	66
Electrical installation, control cables .....	67
Switches 1-4 .....	68
Bus connection .....	68
Connection examples, VLT 6000 HVAC .....	69
<b>Programming</b> .....	<b>71</b>
Control unit LCP .....	71
Control keys for parameter setup .....	71
Indicator lamps .....	72
Local control .....	72
Display mode .....	73
Navigation between display modes .....	75
Changing data .....	76
Manual initialisation .....	76
Quick Menu .....	77
Operation and Display 001-017 .....	79
The Setup configuration .....	79
Setup of user-defined readout .....	80
Load and Motor 100-117 .....	86
Configuration .....	86
Motor power factor (Cos $\phi$ ) .....	91
Reference handling .....	93
Reference type .....	96
Inputs and outputs 300-365 .....	101
Analogue inputs .....	105
Analog/digital outputs .....	108
Relay outputs .....	111
Application functions 400-427 .....	115
Sleep mode .....	116
PID for process control .....	121
PID overview .....	123
Feedback handling .....	123
Service functions 600-631 .....	130
Electrical installation of the relay card .....	135
Description of Real Time Clock .....	136
<b>All about VLT 6000 HVAC</b> .....	<b>139</b>
Status messages .....	139
List of warnings and alarms .....	141
Aggressive environments .....	147
Calculation of resulting reference .....	147
Galvanic isolation (PELV) .....	148
Earth leakage current .....	148
Extreme running conditions .....	149
Peak voltage on motor .....	150
Switching on the input .....	150
Acoustic noise .....	151
Derating for ambient temperature .....	151
Derating for air pressure .....	152
Derating for running at low speed .....	152
Derating for long motor cables or cables with larger cross-section .....	152
Derating for high switching frequency .....	152
Vibration and shock .....	153

Air humidity .....	153
Efficiency .....	154
Mains supply interference/harmonics .....	155
Power factor .....	155
EMC test results (Emission, Immunity) .....	156
EMC Immunity .....	157
Definitions .....	159
Parameter overview and factory settings .....	161
<b>Index</b> .....	<b>168</b>

# VLT 6000 HVAC

**Operating Instructions**  
**Software version: 3.0x**



175ZA691.16

These Operating Instructions can be used for all VLT 6000 HVAC frequency converters with software version 3.0x. The software version number can be seen from parameter 624.



The voltage of the frequency converter is dangerous whenever the equipment is connected to mains. Incorrect installation of the motor or the frequency converter may cause damage to the equipment, serious personal injury or death. Consequently, the instructions in this manual, as well as national and local rules and safety regulations, must be complied with.

### ■ Safety regulations

1. The frequency converter must be disconnected from mains if repair work is to be carried out. Check that the mains supply has been disconnected and that the necessary time has passed before removing motor and mains plugs.
2. The [OFF/STOP] key on the control panel of the frequency converter does not disconnect the equipment from mains and is thus not to be used as a safety switch.
3. Correct protective earthing of the equipment must be established, the user must be protected against supply voltage, and the motor must be protected against overload in accordance with applicable national and local regulations.
4. The earth leakage currents are higher than 3.5 mA.
5. Protection against motor overload is included in the factory setting. Parameter 117, *Motor thermal protection* default value is ETR trip 1.  
Note: The function is initialised at 1.0 x rated motor current and rated motor frequency (see parameter 117, *Motor thermal protection*).

6. Do not remove the plugs for the motor and mains supply while the frequency converter is connected to mains. Check that the mains supply has been disconnected and that the necessary time has passed before removing motor and mains plugs.
7. Reliable galvanic isolation (PELV) is not complied with if the RFI switch is placed in OFF position. This means that all control in - and outputs can only be considered low-voltage terminals with basic galvanic isolation.
8. Please note that the frequency converter has more voltage inputs than L1, L2 and L3, when the DC-bus terminals are used. Check that all voltage inputs have been disconnected and that the necessary time has passed before repair work is commenced.

### ■ Warning against unintended start

1. The motor can be brought to a stop by means of digital commands, bus commands, references or a local stop, while the frequency converter is connected to mains. If personal safety considerations make it necessary to ensure that no unintended start occurs, these stop functions are not sufficient.
2. While parameters are being changed, the motor may start. Consequently, the stop key [OFF/STOP] must always be activated, following which data can be modified.
3. A motor that has been stopped may start if faults occur in the electronics of the frequency converter, or if a temporary overload or a fault in the supply mains or the motor connection ceases.

### ■ Use on isolated mains

See section *RFI Switch* regarding use on isolated mains.

It is important to follow the recommendations regarding installation on IT-mains, since sufficient protection of the complete installation must be observed. Not taking care using relevant monitoring devices for IT-mains may result in damage.

**Warning:**

Touching the electrical parts may be fatal - even after the equipment has been disconnected from mains.

- Using VLT 6002 - 6005, 200-240 V: Wait at least 4 minutes
- Using VLT 6006 - 6062, 200-240 V: Wait at least 15 minutes
- Using VLT 6002 - 6005, 380-460 V: Wait at least 4 minutes
- Using VLT 6006 - 6072, 380-460 V: Wait at least 15 minutes
- Using VLT 6102 - 6352, 380-460 V: Wait at least 20 minutes
- Using VLT 6402 - 6602, 380-460 V: Wait at least 40 minutes
- Using VLT 6002 - 6006, 525-600 V: Wait at least 4 minutes
- Using VLT 6008 - 6027, 525-600 V: Wait at least 15 minutes
- Using VLT 6032 - 6072, 525-600 V: Wait at least 30 minutes
- Using VLT 6102 - 6402, 525-600 V: Wait at least 20 minutes
- Using VLT 6502 - 6652, 525-600 V: Wait at least 30 minutes

175HA490.15

## ■ Introduction to Operating Instructions

These Operating Instructions are a tool intended for persons who are to install, operate and program the VLT 6000 HVAC.

A VLT 6000 HVAC comes with *Operating Instructions* as well as *Quick Setup Guide*. In addition, a *Design Guide* can be ordered for use when designing installations that will include a VLT 6000 HVAC. See *Available literature*.

Operating Instructions:	These are instructions in how to ensure optimum mechanical and electrical installation, commissioning and service. The Operating Instructions also include a description of the software parameters, thereby enabling easy adaptation of the VLT 6000 HVAC to your application.
Quick Setup Guide:	Helps you to quickly install and commission the VLT 6000 HVAC.
Design Guide:	Used when designing installations that include a VLT 6000 HVAC. The Design Guide gives detailed information about VLT 6000 HVAC and HVAC installations, including a selection tool to enable you to choose the right VLT 6000 HVAC with its relevant options and modules. The Design Guide also contains examples of the most common HVAC applications. Furthermore, the Design Guide has all information relating to serial communication.

These Operating Instructions are divided into four sections with information about VLT 6000 HVAC.

Introduction to HVAC:	This section tells you the advantages you can obtain by using a VLT 6000 HVAC - such as AEO, Automatic Energy Optimization, RFI filters and other HVAC-relevant functions. This section also contains examples of application as well as information about Danfoss and CE-labelling.
Installation:	This section tells you how to carry out mechanically correct installation of the VLT 6000 HVAC. In addition, this section includes a description of how to ensure that the installation of your VLT 6000 HVAC is EMC-correct. Furthermore, a list is given of mains and motor connections, together with a description of the control card terminals.
Programming:	This section describes the control unit and the software parameters for the VLT 6000 HVAC. Also included is a guide to the Quick Setup menu, which allows you to get started on your application very quickly.
All about VLT 6000 HVAC	This section gives information about status, warning and error messages from the VLT 6000 HVAC. Additionally, information is given on technical data, service, factory settings and special conditions.



Indicates a general warning



Indicates a high-voltage warning



**NB!:**

Indicates something to be noted by the reader

**■ Available literature**

Below is a list of the literature available for VLT 6000 HVAC. It must be noted that there may be deviations from one country to the next.

Please also refer to our web site <http://drives.danfoss.com> for information about new literature.

**Supplied with the unit:**

---

Operating instructions .....	MG.61.AX.YY
Quick Setup .....	MG.60.CX.YY
High Power Introduction Guide .....	MI.90.JX.YY

**Communication with VLT 6000 HVAC:**

---

Profibus Manual .....	MG.90.DX.YY
Metasys N2 Manual .....	MG.60.FX.YY
LonWorks Manual .....	MG.60.EX.YY
Landis/Staefa Apogee FLN Manual .....	MG.60.GX.YY
Modbus RTU Manual .....	MG.10.SX.YY
DeviceNet Manual .....	MG.50.HX.YY

**Instructions for VLT 6000 HVAC:**

---

LCP Remote Kit IP20 .....	MI.56.AX.51
LCP Remote Kit IP54 .....	MI.56.GX.52
LC-filter .....	MI.56.DX.51
IP20 terminal cover .....	MI.56.CX.51

**Various literature for VLT 6000 HVAC:**

---

Operating Instructions .....	MG.60.AX.YY
Design Guide .....	MG.61.BX.YY
Data sheet .....	MD.60.AX.YY
VLT 6000 HVAC Cascade Controller .....	MG.60.IX.YY

X = version number

YY = language version

**■ VLT 6000 Advantages in a HVAC installation**

One advantage involved in using a VLT 6000 HVAC is that this unit has been designed to regulate the speed of fans and rotary pumps while consuming the smallest possible amount of energy. Consequently, if a VLT 6000 HVAC is used in a HVAC installation, optimum energy savings are guaranteed, since less energy is used with a frequency converter than with the traditional HVAC regulation principles. Another advantage in using the VLT 6000 HVAC is that regulation is improved and can easily adapt to a new flow or pressure requirement in an installation. The use of a VLT 6000 HVAC offers the following additional advantages:

- VLT 6000 HVAC has been designed for HVAC applications.
- A wide power range - from 1.1-500 kW units with a unique design.
- IP 20 and IP 54 enclosures that can be mounted side by side. For power sizes  $\geq 90\text{kW}$  ( $\geq 30\text{kW}$  for 200 V) IP 00 is also available.
- All unit types, except 525-600 V units, are available with an integral RFI filter, complying with EN 55011 class A1 in the case of a 150 m screened/armoured motor cable and EN 55011 class B in the case of a screened/armoured motor cable up to 50 m long.
- User-friendly design, which makes VLT 6000 HVAC easy to install, both mechanically and electrically.
- Detachable LCP control panel with Hand-Off-Auto buttons and a graphics display of local speed.
- High starting torque owing to Automatic Energy Optimization (AEO).
- Automatic Motor Adaptation (AMA) ensures optimum motor utilisation.
- Integral PID regulator with option of connecting two feedback signals (in connection with zoning), as well as setting of two set-points.



- Sleep mode, which automatically turns the motor off, e.g. when there is no need for more pressure or flow in a system.
- The "flying start" function enables the unit to catch a rotating fan.

- Automatic ramp up/down to ensure that the VLT 6000 HVAC will not trip during acceleration or deceleration.
- All standard units have three integral, serial protocols - RS 485 FC protocol, Johnson's Metasys N2 and Landis/Staefa Apogee FLN. Communication option cards that can be connected are LonWorks, DeviceNet, Modbus RTU and Profibus.

### ■ Control principle

A frequency converter rectifies AC voltage from mains into DC voltage, after which this DC voltage is converted into a AC current with a variable amplitude and frequency.

The motor is thus supplied with variable voltage and frequency, which enables infinitely variable speed control of three-phased, standard AC motors.

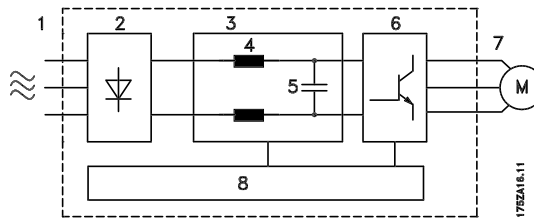

#### 1. Mains voltage

3 x 200 - 240 V AC, 50 / 60 Hz.  
3 x 380 - 460 V AC, 50 / 60 Hz.  
3 x 525 - 600 V AC, 50 / 60 Hz.

#### 2. Rectifier

A three-phase rectifier bridge that rectifies AC current into DC current.

#### 3. Intermediate circuit

DC voltage = 1.35 x mains voltage [V].

#### 4. Intermediate circuit coils

Even out the intermediate circuit voltage and reduce the harmonic current feedback to the mains supply.

#### 5. Intermediate circuit capacitors

Even out the intermediate circuit voltage.

#### 6. Inverter

Converts DC voltage into variable AC voltage with a variable frequency.

#### 7. Motor voltage

Variable AC voltage, 0-100% of mains supply voltage.

#### 8. Control card

This is where to find the computer that controls the inverter which generates the pulse pattern by which the DC voltage is converted into variable AC voltage with a variable frequency.

■ **AEO - Automatic Energy Optimization**

Normally, the U/f characteristics have to be set on the basis of the expected load at different frequencies. However, knowing the load at a given frequency in an installation is often a problem. This problem can be solved by using a VLT 6000 HVAC with its integral Automatic Energy Optimization (AEO), which ensures optimum energy utilization. All VLT 6000 HVAC units feature this function as a factory setting, i.e. it is not necessary to adjust the frequency converter U/f ratio in order to obtain maximum energy savings. In other frequency converters, the given load and voltage/frequency ratio (U/f) must be assessed to carry out correct setting of the frequency converter. Using Automatic Energy Optimization (AEO), you no longer need to calculate or assess the system characteristics of the installation, since Danfoss VLT 6000 HVAC units guarantee optimum, load-dependent energy consumption by the motor at all times.

The figure on the right illustrates the working range of the AEO function, within which energy optimization is enabled.

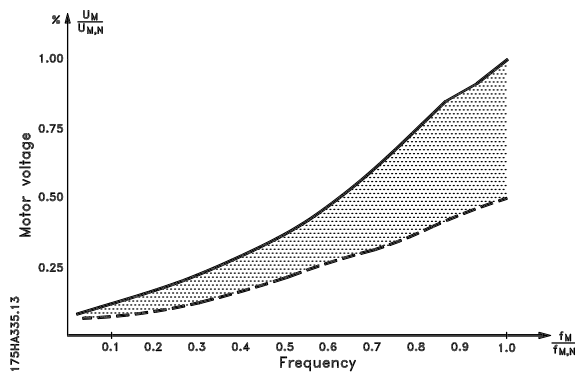

If the AEO function has been selected in parameter 101, *Torque characteristics*, this function will be constantly active. If there is a major deviation from the optimum U/f ratio, the frequency converter will quickly adjust itself.

**Advantages of the AEO function**

- Automatic energy optimization
- Compensation if an oversize motor is used
- AEO matches operations to daily or seasonal fluctuations
- Energy savings in a constant air volume system
- Compensation in the oversynchronous working range
- Reduces acoustic motor noise

### ■ Example of application - Speed control of fan in ventilation system

The AHU installation is able to distribute air throughout the building or to one or several parts of a building. Normally, an AHU installation consists of a fan and a motor that supply air, a fan scroll and a duct system with filters. If centralised air distribution is applied, the efficiency of the installation will increase and major energy savings can be made. A VLT 6000 HVAC enables excellent control and monitoring, thereby ensuring perfect conditions in the building at all times.

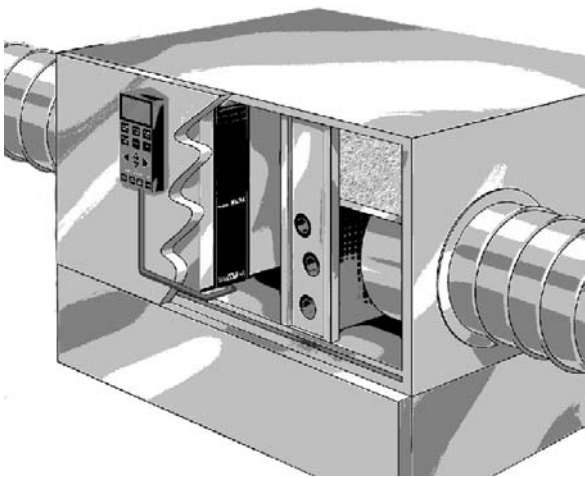

This example shows an application with *Run permissive*, warning against no load and warning for filter change. The *Run permissive* function ensures that the frequency converter will not start the motor until the discharge damper has opened. If the V-belt to the fan breaks and if the filter is to be changed, this application will also give a warning on an output.

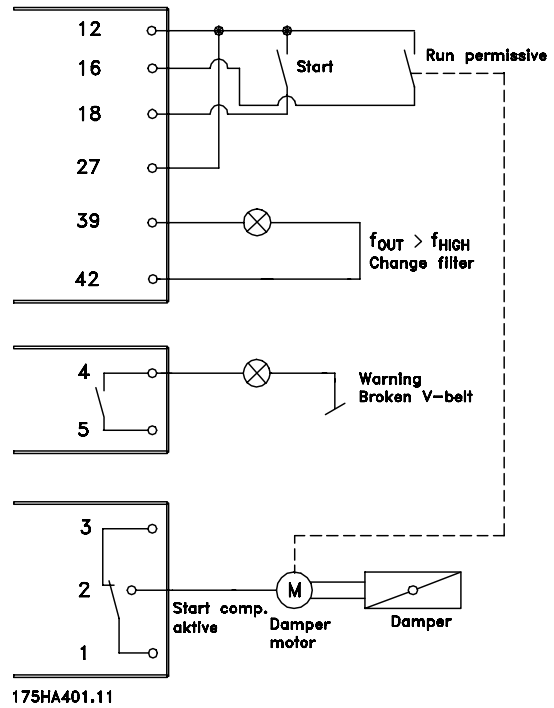

Introduction to HVAC

Set the following parameters:

Par. 100	Configuration	Open loop [0]
Par. 221	Warning: Low current, $I_{LOW}$	Depends on unit
Par. 224	Warning: High frequency, $f_{HIGH}$	
Par. 300	Terminal 16 Digital inputs	Run permissive [8]
Par. 302	Terminal 18 Digital inputs	Start [1]
Par. 308	Terminal 53, analogue input voltage	Reference [1]
Par. 309	Terminal 53, min. scaling	0 v
Par. 310	Terminal 53, max. scaling	10 v
Par. 319	Output	Output frequency greater than $f_{HIGH}$ par. 224
Par. 323	Relay 1	Start command active [27]
Par. 326	Relay 2	Alarm or warning [12]
Par. 409	Function at no load	Warning [1]

### ■ Example of application - Constant pressure regulation in water supply system

The demand for water from waterworks varies considerably during the course of a day. In the night, practically no water is used, while in the morning and in the evening the consumption is high. In order to maintain a suitable pressure in the water supply lines in relation to the current demand, the water supply pumps are equipped with speed control. The use of frequency converters enables the energy consumed by the pumps to be kept at a minimum, while optimizing the water supply to consumers.

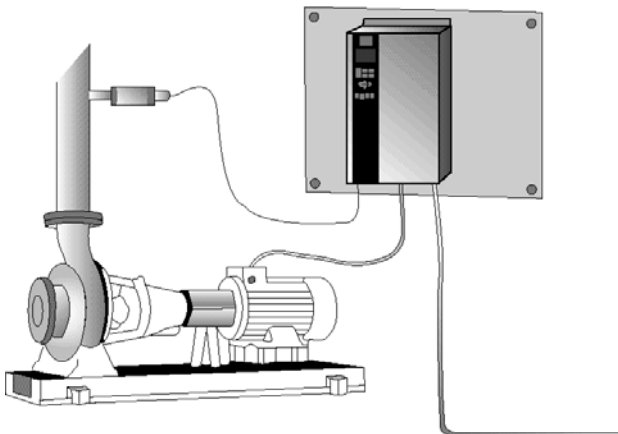

A VLT 6000 HVAC with its integral PID controller ensures simple and quick installation. For example, an IP54 unit can be mounted close to the pump on the wall and the existing line cables can be used as mains supply to the frequency converter. A Pressure transmitter (e.g. Danfoss MBS 33 0-10) bar can be fitted a couple of metres from the joint outlet point from the waterworks to obtain closed loop regulation. Danfoss MBS 33 is a two-wire transmitter (4-20 mA) that can be powered directly from a VLT 6000 HVAC. The required setpoint (e.g. 5 bar) can be set locally in parameter 418 *Setpoint 1*.

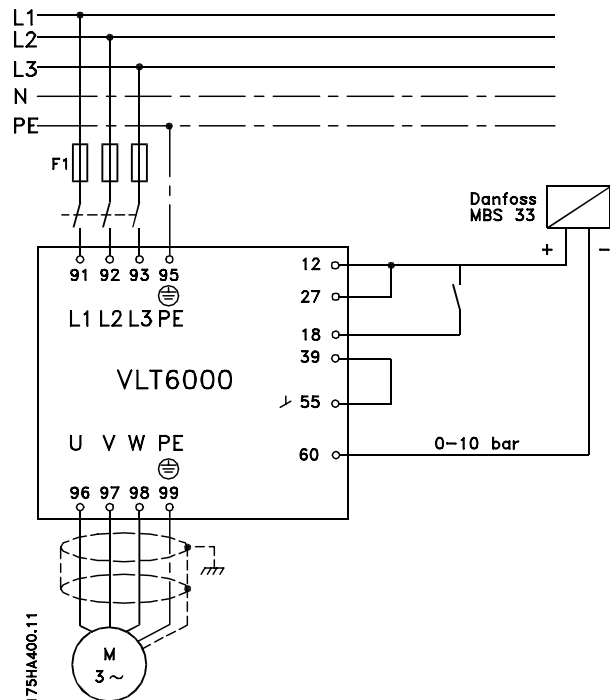

Set the following parameters:

Par. 100	Configuration	Closed loop [1]
Par. 205	Maximum reference	10 bar
Par. 302	Terminal 18 Digital inputs	Start [1]
Par. 314	Terminal 60, analog input current	Feedback signal [2]
Par. 315	Terminal 60, min. scaling	4 mA
Par. 316	Terminal 60, max. scaling	20 mA
Par. 403	Sleep mode timer	10 sec.
Par. 404	Sleep frequency	15 Hz
Par. 405	Wake-up frequency	20 Hz
Par. 406	Boost setpoint	125%
Par. 413	Minimum feedback	0
Par. 414	Maximum feedback	10 bar
Par. 415	Process units	Bar [16]
Par. 418	Setpoint 1	5 bar
Par. 420	PID normal/inverse control	Normal
Par. 423	PID proportional gain	0.5-1.0
Par. 424	PID integration time	3-10
Par. 427	PID low pass filter	0.5-1.5

**■ Fire mode**

**NB!:**

Please note the frequency converter is only one component of the HVAC system.

Correct function of Fire Mode depends on the correct design and selection of system components. Ventilation systems working in life safety applications have to be approved by the local fire Authorities.

***Non-interruption of the frequency converter due to Fire Mode operation may cause over pressure and result in damage to HVAC system and components, including dampers and air ducts. The frequency converter itself may be damaged and it may cause damage or fire.***

***Danfoss A/S accepts no responsibility for errors, malfunctions personal injury or any damage to the frequency converter itself or components herein, HVAC systems and components herein or other property when the frequency converter has been programmed for Fire Mode. In no event shall Danfoss be liable to the end user or any other party for any direct or indirect, special or consequential damage or loss suffered by such party, which has occurred due to the frequency converter being programmed and operated in Fire Mode***

The Fire Mode function is made to ensure the VLT 6000 can run without interruption. This means most alarms and warnings will not cause a trip and trip lock is disabled. This is useful in case of fire or other emergencies. Until the motor wires or the frequency converter itself are destroyed every attempt is made to keep running. A warning will flash when these limits have been exceeded. If the warning still flashes after a power cycle please contact your local Danfoss supplier. In the following is a table to show the alarms and when the frequency converter changes state depending on selection in parameter 430. Trip and lock ([0] in parameter 430) are valid in normal operation mode. Fire Mode trip and reset ([1] or [2] in parameter 430) means that a reset is automatically performed without the need of manual resetting. Go to Fire Mode bypass ([3] in parameter 430) is valid in case one of the mentioned alarms causes a trip. After the in parameter 432 selected time delay has passed an output is set. This output is programmed in parameter 319, 321, 323 or 326. If a relay option is fitted it can also be selected in parameter 700, 703, 706 or 709. In parameter 300 and 301 it can be selected if the logic, for the Fire Mode activation, shall be active high or low. Please note parameter 430 must be different to [0] for the Fire Mode to be enabled.

To be able to use Fire Mode please also note that input 27 must be "high" and no coast bit present via fieldbus. To ensure that no coast can interrupt Fire Mode via fieldbus please select Digital Input [0] in par. 503. Then coasting via fieldbus disabled.

<b>No.</b>	<b>Description</b>	<b>TRIP [0]</b>	<b>LOCK [0]</b>	<b>FIRE MODE Trip &amp; reset [1], [2]</b>	<b>Go to FIRE MODE BYPASS [3]</b>
2	Live zero fault (LIVE ZERO ERROR)	X			
4	Mains imbalance (MAINS IMBALANCE)	x	x		x
7	Overvoltage (DC LINK OVERVOLT)	x			
8	Undervoltage (DC LINK UNDERVOLT)	x			
9	Inverter overloaded (INVERTER TIME)	x			
10	Motor overloaded (MOTOR TIME)	x			
11	Motor thermistor(MOTOR THERMISTOR)	x			
12	Current limit (CURRENT LIMIT)	x			
13	Overcurrent (OVERCURRENT)	x	x	x	x
14	Earth fault (EARTH FAULT)	x	x	x	x
15	Switch mode fault (SWITCH MODE FAULT)	x	x	x	x
16	Short-circuit (CURR.SHORT CIRCUIT)	x	x	x	x
17	Serial communication timeout (STD BUSTIMEOUT)	x			
18	HPFB bus timeout (HPFB TIMEOUT)	x			
22	Auto-optimation fault (AMA FAULT)	x			
29	Heat-sink temperature too high (HEAT SINK OVERTEMP.)	x	x		x
30	Motor phase U missing (MISSING MOT.PHASE U)	x			
31	Motor phase V missing (MISSING MOT.PHASE V)	x			
32	Motor phase W missing (MISSING MOT.PHASE W)	x			
34	HPFB communication fault (HPFB TIMEOUT)	x			
37	Inverter fault (GATE DRIVE FAULT)	x	x	x	x
60	Safety stop (EXTERNAL FAULT)	x			
63	Output current low (I MOTOR < I LOW)	x			
80	Fire mode was active (FIRE MODE WAS ACTIVE)	x			
99	Unknown fault (UNKNOWN FAULT)	x	x		

**■ CE labelling**
**What is CE labelling?**

The purpose of CE labelling is to avoid technical obstacles to trade within EFTA and the EU. The EU has introduced the CE label as a simple way of showing whether a product complies with the relevant EU directives. The CE label says nothing about the specifications or quality of the product. Frequency converters are regulated by three EU directives:

**The machinery directive (98/37/EEC)**

All machines with critical moving parts are covered by the machinery directive, which came into force on 1 January 1995. Since a frequency converter is largely electrical, it does not fall under the machinery directive. However, if a frequency converter is supplied for use in a machine, we provide information on safety aspects relating to the frequency converter. We do this by means of a manufacturer's declaration.

**The low-voltage directive (73/23/EEC)**

Frequency converters must be CE labelled in accordance with the low-voltage directive, which came into force on 1 January 1997. The directive applies to all electrical equipment and appliances used in the 50 - 1000 Volt AC and the 75 - 1500 Volt DC voltage ranges. Danfoss CE labels in accordance with the directive and issues a declaration of conformity upon request.

**The EMC directive (89/336/EEC)**

EMC is short for electromagnetic compatibility. The presence of electromagnetic compatibility means that the mutual interference between different components/appliances is so small that the functioning of the appliances is not affected.

The EMC directive came into force on 1 January 1996. Danfoss CE labels in accordance with the directive and issues a declaration of conformity upon request. In order that EMC-correct installation can be carried out, this manual gives detailed instructions for installation. In addition, we specify the standards which our different products comply with. We offer the filters that can be seen from the specifications and provide other types of assistance to ensure the optimum EMC result.

In the great majority of cases, the frequency converter is used by professionals of the trade as a complex component forming part of a larger appliance, system or installation. It must be noted that the responsibility for the final EMC properties of the appliance, system or installation rests with the installer.

NOTE: VLT 6001-6072, 525-600 V are not CE labelled.

**■ PC software and serial communication**

Danfoss offers various options for serial communication. Using serial communication, it is possible to monitor, program and control one or several frequency converters from a centrally located computer.

All VLT 6000 HVAC units have a RS 485 port as standard with a choice of four protocols. The protocols selectable in parameter 500 *Protocols* are:

- FC protocol
- Johnson Controls Metasys N2
- Landis/Staefa Apogee FLN
- Modbus RTU

A bus option card allows higher transmission speed than RS 485. In addition, a higher number of units can be linked to the bus and alternative transmission media can be used. Danfoss offers the following option cards for communication:

- Profibus
- LonWorks
- DeviceNet

Information on the installation of various options is not included in this manual.

Using the RS 485 port enables communication, e.g. with a PC. A Windows™ program, called *MCT 10*, is

available for this purpose. It can be used to monitor, program and control one or several VLT 6000 HVAC units. For further information, see the *Design Guide* for VLT 6000 HVAC or contact Danfoss.

---

**500-566 Serial communication**

---

**NB!:**

Information on the use of RS-485 serial interface is not included in this manual. For further information, see the *Design Guide* for VLT 6000 HVAC or contact Danfoss.

---

**■ Unpacking and ordering a VLT frequency converter**

If you are in doubt as to which frequency converter you have received and which options it contains, use the following to find out.

---

**■ Type code ordering number string**

On the basis of your order, the frequency converter is given an ordering number that can be seen from the nameplate on the unit. The number may look as follows:

**VLT-6008-H-T4-B20-R3-DL-F10-A00-C0**

This means that the frequency converter ordered is a VLT 6008 for three-phase mains voltage of 380-460 V (**T4**) in Bookstyle enclosure IP 20 (**B20**). The hardware variant is with integral RFI filter, classes A & B (**R3**). The frequency converter features a control unit (**DL**) with a PROFIBUS option card (**F10**). No option card (A00) and no conformal coating (C0) Character no. 8 (**H**) indicates the application range of the unit: **H** = HVAC.

IP 00: This enclosure is only available for the larger power sizes of the VLT 6000 HVAC series. It is recommended for installation in standard cabinets.

IP 20 Bookstyle: This enclosure is designed for cabinet installation. It takes up a minimum of space and can be fitted side-by-side without installation of extra cooling equipment.

IP 20/NEMA 1: This enclosure is used as standard enclosure for VLT 6000 HVAC. It is ideal for cabinet installation in areas where a high degree of protection is required. This enclosure also permits side-by-side installation.

IP 54: This enclosure can be fitted direct to the wall. Cabinets are not required. IP 54 units can also be installed side-by-side.

---

**Hardware variant**

---

The units in the programme are available in the following hardware variants:

ST: Standard unit with or without control unit.

Without DC terminals, except for

VLT 6042-6062, 200-240 V

VLT 6016-6072, 525-600 V

SL: Standard unit with DC terminals.

EX: Extended unit with control unit, DC terminals, connection of external 24 V DC supply for back-up of control PCB.

DX: Extended unit with control unit, DC terminals, built-in mains fuses and disconnect, connection of external 24 V DC supply for back-up of control PCB.

PF: Standard unit with 24 V DC supply for back-up of control PCB and built-in main fuses. No DC terminals.

PS: Standard unit with 24 V DC supply for back-up of control PCB. No DC terminals.

PD: Standard unit with 24 V DC supply for back-up of control PCB, built-in main fuses and disconnect. No DC terminals.

---

**RFI filter**

---

Bookstyle units always come *with* an integral RFI filter that complies with EN 55011-B with 20 m screened/armoured motor cable and EN 55011-A1 with 150 m screened/armoured motor cable. Units for mains voltage of 240 V and a motor power of up to and including 3.0 kW (VLT 6005) and units for a mains voltage of 380-460 V and a motor power of up to 7.5 kW (VLT 6011) are always supplied with an integral class A1 & B filter. Units for higher motor power than these (3.0 and 7.5 kW, respectively) can be ordered either with or without an RFI filter.

---

**Control unit (keypad and display)**

---

All types of units in the programme, except for IP21 VLT 6402-6602, 380-460 V, VLT 6502-6652, 525-600 V and IP 54 units, can be ordered either with or without the control unit. IP 54 units always come *with* a control unit. All types of units in the programme are available with built-in application options including a relay card with four relays or a cascade controller card.

---

**Conformal Coating**

---

All types of units in the programme are available with or without conformal coating of the PCB.

VLT 6402-6602, 380-460 V and VLT 6102-6652, 525-600 V are only available coated.



**200-240 V**

Typecode	T2	C00	B20	C20	CN1	C54	ST	SL	R0	R1	R3
Position in string	9-10	11-13	11-13	11-13	11-13	11-13	14-15	14-15	16-17	16-17	16-17
1.1 kW/1.5 HP	6002		X	X		X	X				X
1.5 kW/2.0 HP	6003		X	X		X	X				X
2.2 kW/3.0 HP	6004		X	X		X	X				X
3.0 kW/4.0 HP	6005		X	X		X	X				X
4.0 kW/5.0 HP	6006			X		X	X	X	X		X
5.5 kW/7.5 HP	6008			X		X	X	X	X		X
7.5 kW/10 HP	6011			X		X	X	X	X		X
11 kW/15 HP	6016			X		X	X	X	X		X
15 kW/20 HP	6022			X		X	X	X	X		X
18.5 kW/25 HP	6027			X		X	X	X	X		X
22 kW/30 HP	6032			X		X	X	X	X		X
30 kW/40 HP	6042	X			X	X	X		X	X	
37 kW/50 HP	6052	X			X	X	X		X	X	
45 kW/60 HP	6062	X			X	X	X		X	X	

**380-460 V**

Typecode	T4	C00	B20	C20	CN1	C54	ST	SL	EX	DX	PS	PD	PF	R0	R1	R3
Position in string	9-10	11-13	11-13	11-13	11-13	11-13	14-15	14-15	14-15	14-15	14-15	14-15	14-15	16-17	16-17	16-17
1.1 kW/1.5 HP	6002		X	X		X	X									X
1.5 kW/2.0 HP	6003		X	X		X	X									X
2.2 kW/3.0 HP	6004		X	X		X	X									X
3.0 kW/4.0 HP	6005		X	X		X	X									X
4.0 kW/5.0 HP	6006		X	X		X	X									X
5.5 kW/7.5 HP	6008		X	X		X	X									X
7.5 kW/10 HP	6011		X	X		X	X									X
11 kW/15 HP	6016			X		X	X	X						X		X
15 kW/20 HP	6022			X		X	X	X						X		X
18.5 kW/25 HP	6027			X		X	X	X						X		X
22 kW/30 HP	6032			X		X	X	X						X		X
30 kW/40 HP	6042			X		X	X	X						X		X
37 kW/50 HP	6052			X		X	X	X						X		X
45 kW/60 HP	6062			X		X	X	X						X		X
55 kW/75 HP	6072			X		X	X	X						X		X
75 kW/100 HP	6102			X		X	X	X						X		X
90 kW/125 HP	6122			X		X	X	X						X		X
110 kW/150 HP	6152	X			X	X	X		X	X	X	X	X	X	X	
132 kW/200 HP	6172	X			X	X	X		X	X	X	X	X	X	X	
160 kW/250 HP	6222	X			X	X	X		X	X	X	X	X	X	X	
200 kW/300 HP	6272	X			X	X	X		X	X	X	X	X	X	X	
250 kW/350 HP	6352	X			X	X	X		X	X	X	X	X	X	X	
315 kW/450 HP	6402	X			X	X	X		X	X	X	X	X	X	X	
355 kW/500 HP	6502	X			X	X	X		X	X	X	X	X	X	X	
400 kW/550 HP	6552	X			X	X	X		X	X	X	X	X	X	X	
450 kW/600 HP	6602	X			X	X	X		X	X	X	X	X	X	X	

**Voltage**

T2: 200-240 VAC

T4: 380-460 VAC

**Enclosure**

C00: Compact IP 00

B20: Bookstyle IP 20

C20: Compact IP 20

CN1: Compact NEMA 1

C54: Compact IP 54

**Hardware variant**

ST: Standard

SL: Standard with DC terminals

EX: Extended with 24 V supply and DC terminals

DX: Extended with 24 V supply, DC terminals,

disconnect and fuse

PS: Standard with 24 V supply

PD: Standard with 24 V supply, fuse and disconnect

PF: Standard with 24 V supply and fuse

**RFI filter**

R0: Without filter

R1: Class A1 filter

R3: Class A1 and B filter



**NB!:**  
NEMA 1 exceeds IP 20

**525-600 V**

Typecode Position in string	T6 9-10	C00 11-13	C20 11-13	CN1 11-13	ST 14-15	R0 16-17
1.1 kW/1.5 HP	6002		X	X	X	X
1.5 kW/2.0 HP	6003		X	X	X	X
2.2 kW/3.0 HP	6004		X	X	X	X
3.0 kW/4.0 HP	6005		X	X	X	X
4.0 kW/5.0 HP	6006		X	X	X	X
5.5 kW/7.5 HP	6008		X	X	X	X
7.5 kW/10 HP	6011		X	X	X	X
11 kW/15 HP	6016			X	X	X
15 kW/20 HP	6022			X	X	X
18.5 kW/25 HP	6027			X	X	X
22 kW/30 HP	6032			X	X	X
30 kW/40 HP	6042			X	X	X
37 kW/50 HP	6052			X	X	X
45 kW/60 HP	6062			X	X	X
55 kW/75 HP	6072			X	X	X

**VLT 6102-6652, 525-600 V**

Typecode Position in string	T6 9-10	C00 11-13	CN1 11-13	C54 11-13	ST 14-15	EX 14-15	DX 14-15	PS 14-15	PD 14-15	PF 14-15	R0 16-17	R1 16-17 <sup>1)</sup>
75 kW / 100 HP	6102	X	X	X	X	X	X	X	X	X	X	X
90 kW / 125 HP	6122	X	X	X	X	X	X	X	X	X	X	X
110 kW / 150 HP	6152	X	X	X	X	X	X	X	X	X	X	X
132 kW / 200 HP	6172	X	X	X	X	X	X	X	X	X	X	X
160 kW / 250 HP	6222	X	X	X	X	X	X	X	X	X	X	X
200 kW / 300 HP	6272	X	X	X	X	X	X	X	X	X	X	X
250 kW / 350 HP	6352	X	X	X	X	X	X	X	X	X	X	X
315 kW / 400 HP	6402	X	X	X	X	X	X	X	X	X	X	X
400 kW / 500 HP	6502	X	X	X	X	X	X	X	X	X	X	
450 kW / 600 HP	6602	X	X	X	X	X	X	X	X	X	X	
500 kW / 650 HP	6652	X	X	X	X	X	X	X	X	X	X	

1) R1 is not available with DX, PF, PD options.



**NB!:**  
NEMA 1 exceeds IP 20

**Voltage**

T6: 525-600 VAC

**Enclosure**

C00: Compact IP 00

C20: Compact IP 20

CN1: Compact NEMA 1

C54: Compact IP 54

**Hardware variant**

ST: Standard

EX: Extended with 24 V supply and DC terminals

DX: Extended with 24 V supply, DC terminals,  
disconnect and fuse

PS: Standard with 24 V supply

PD: Standard with 24 V supply, fuse and disconnect

PF: Standard with 24 V supply and fuse

**RFI filter**

R0: Without filter

R1: Class A1 filter

**Optional selections, 200-600 V**

<b>Display</b>		Position: 18-19
D0 <sup>1)</sup>	Without LCP	
DL	With LCP	
<b>Fieldbus option</b>		Position: 20-22
F00	No options	
F10	Profibus DP V1	
F13	Profibus FMS	
F30	DeviceNet	
F40	LonWorks free topology	
F41	LonWorks 78 kBps	
F42	LonWorks 1.25 MBps	
<b>Application option</b>		Position: 23-25
A00	No options	
A31 <sup>2)</sup>	Relay card 4 relays	
A32	Cascade Controller	
A40	Real Time Clock	
<b>Coating</b>		Position: 26-27
C0 <sup>3)</sup>	No coating	
C1	With coating	

1) Not available with enclosure compact IP 54

2) Not available with fieldbus options (Fxx)

3) Not available for power sizes from 6402 to 6602, 380-460 V and 6102-6652, 525-600 V

### ■ Ordering form

VLT 6   H T    R D F   A  C

**Power sizes**  
e.g. 6008

**Application range**  
H

**Mains voltage**  
T2  
T4  
T6

**Enclosure**  
B20  
C00  
C20  
C54  
CN1

**Hardware variant**  
ST  
SL  
PS  
PD  
PF  
EX  
DX

**RFI filter**  
R0  
R1  
R3

**Display unit (LCP)**  
DO  
DL

**Fieldbus option card**  
F00  
F10  
F13  
F30  
F40  
F41  
F42

**Application option card**  
A00  
A31  
A32  
A40

**Coating**  
C0  
C1

6002  
6003  
6004  
6005  
6006  
6008  
6011  
6016  
6022  
6027  
6032  
6042  
6052  
6062  
6072  
6102  
6122  
6152  
6172  
6222  
6272  
6352  
6402  
6502  
6552  
6602  
6652

No. units of this type

Required delivery date

Ordered by:

Date: \_\_\_\_\_

Take a copy of the ordering forms. Fill them in and send or fax your order to the nearest office of the Danfoss sales organisation

175ZA895.15

**■ Mains supply (L1, L2, L3)**

## Mains supply (L1, L2, L3):

Supply voltage 200-240 V units .....	3 x 200/208/220/230/240 V ±10%
Supply voltage 380-460 V units .....	3 x 380/400/415/440/460 V ±10%
Supply voltage 525-600 V units .....	3 x 525/550/575/600 V ±10%
Supply frequency .....	48-62 Hz ± 1%

## Max. imbalance of supply voltage:

VLT 6002-6011, 380-460 V and 525-600 V and VLT 6002-6005, 200-240 V .....	±2.0% of rated supply voltage
VLT 6016-6072, 380-460 V and 525-600 V and VLT 6006-6032, 200-240 V .....	±1.5% of rated supply voltage
VLT 6102-6602, 380-460 V and VLT 6042-6062, 200-240 V .....	±3.0% of rated supply voltage
VLT 6102-6652, 525-600 V .....	±3% of rated supply voltage
True Power factor ( $\lambda$ ) .....	0.90 nominal at rated load
Displacement Power Factor (cos. $\phi$ ) .....	near unity (>0.98)
No. of switches on supply input L1, L2, L3 .....	approx. 1 time/2 min.
Max. short-circuit current .....	100.000 A

## VLT output data (U, V, W):

Output voltage .....	0-100% of supply voltage
Output frequency:	
Output frequency 6002-6032, 200-240V .....	0-120 Hz, 0-1000 Hz
Output frequency 6042-6062, 200-240V .....	0-120 Hz, 0-450 Hz
Output frequency 6002-6062, 380-460V .....	0-120 Hz, 0-1000 Hz
Output frequency 6072-6602, 380-460V .....	0-120 Hz, 0-450 Hz
Output frequency 6002-6016, 525-600V .....	0-120 Hz, 0-1000 Hz
Output frequency 6022-6062, 525-600V .....	0-120 Hz, 0-450 Hz
Output frequency 6072, 525-600V .....	0-120 Hz, 0-450 Hz
Output frequency 6102-6352, 525-600V .....	0-132 Hz, 0-200 Hz
Output frequency 6402-6652, 525-600V .....	0-132 Hz, 0-150 Hz
Rated motor voltage, 200-240 V units .....	200/208/220/230/240 V
Rated motor voltage, 380-460 V units .....	380/400/415/440/460 V
Rated motor voltage, 525-600 V units .....	525/550/575 V
Rated motor frequency .....	50/60 Hz
Switching on output .....	Unlimited
Ramp times .....	1 - 3600 sec.

## Torque characteristics:

Starting torque .....	110% for 1 min.
Starting torque (parameter 110 <i>High break-away torque</i> ) .....	Max. torque: 160% for 0.5 sec.
Acceleration torque .....	100%
Overload torque .....	110%

Installation

**Control card, digital inputs:**

---

Number of programmable digital inputs .....	8
Terminal nos. ....	16, 17, 18, 19, 27, 29, 32, 33
Voltage level .....	0-24 V DC (PNP positive logics)
Voltage level, logical '0' .....	< 5 V DC
Voltage level, logical '1' .....	>10 V DC
Maximum voltage on input .....	28 V DC
Input resistance, $R_i$ .....	2 k
Scanning time per input .....	3 msec.

*Reliable galvanic isolation: All digital inputs are galvanically isolated from the supply voltage (PELV). In addition, the digital inputs can be isolated from the other terminals on the control card by connecting an external 24 V DC supply and opening switch 4. See Switches 1-4.*

**Control card, analogue inputs**

---

No. of programmable analogue voltage inputs/thermistor inputs .....	2
Terminal nos. ....	53, 54
Voltage level .....	0 - 10 V DC (scalable)
Input resistance, $R_i$ .....	approx. 10 k
No. of programmable analogue current inputs .....	1
Terminal no ground. ....	55
Current range .....	0/4 - 20 mA (scalable)
Input resistance, $R_i$ .....	200
Resolution .....	10 bit + sign
Accuracy on input .....	Max. error 1% of full scale
Scanning time per input .....	3 msec.

*Reliable galvanic isolation: All analogue inputs are galvanically isolated from the supply voltage (PELV) and other high-voltage terminals.*

**Control card, pulse input:**

---

No. of programmable pulse inputs .....	3
Terminal nos. ....	17, 29, 33
Max. frequency on terminal 17 .....	5 kHz
Max. frequency on terminals 29, 33 .....	20 kHz (PNP open collector)
Max. frequency on terminals 29, 33 .....	65 kHz (Push-pull)
Voltage level .....	0-24 V DC (PNP positive logics)
Voltage level, logical '0' .....	< 5 V DC
Voltage level, logical '1' .....	>10 V DC
Maximum voltage on input .....	28 V DC
Input resistance, $R_i$ .....	2 k
Scanning time per input .....	3 msec.
Resolution .....	10 bit + sign
Accuracy (100-1 kHz), terminals 17, 29, 33 .....	Max. error: 0.5% of full scale
Accuracy (1-5 kHz), terminal 17 .....	Max. error: 0.1% of full scale
Accuracy (1-65 kHz), terminals 29, 33 .....	Max. error: 0.1% of full scale

*Reliable galvanic isolation: All pulse inputs are galvanically isolated from the supply voltage (PELV). In addition, pulse inputs can be isolated from the other terminals on the control card by connecting an external 24 V DC supply and opening switch 4. See Switches 1-4.*

**Control card, digital/pulse and analogue outputs:**

---

No. of programmable digital and analogue outputs .....	2
Terminal nos. ....	42, 45
Voltage level at digital/pulse output .....	0 - 24 V DC
Minimum load to ground (terminal 39) at digital/pulse output .....	600
Frequency ranges (digital output used as pulse output) .....	0-32 kHz

---

Current range at analogue output ..... 0/4 - 20 mA  
 Maximum load to ground (terminal 39) at analogue output ..... 500  
 Accuracy of analogue output ..... Max. error: 1.5% of full scale  
 Resolution on analogue output ..... 8 bit  
*Reliable galvanic isolation: All digital and analogue outputs are galvanically isolated from the supply voltage (PELV) and other high-voltage terminals.*

Control card, 24 V DC supply:

Terminal nos. .... 12, 13  
 Max. load ..... 200 mA  
 Terminal nos. ground ..... 20, 39  
*Reliable galvanic isolation: The 24 V DC supply is galvanically isolated from the supply voltage (PELV), but has the same potential as the analogue outputs.*

Control card, RS 485 serial communication:

Terminal nos. .... 68 (TX+, RX+), 69 (TX-, RX-)  
*Reliable galvanic isolation: Full galvanic isolation (PELV).*

Relay outputs:<sup>1)</sup>

No. of programmable relay outputs ..... 2  
 Terminal nos., control card (resistive load only) ..... 4-5 (make)  
 Max. terminal load (AC1) on 4-5, control card ..... 50 V AC, 1 A, 50 VA  
 Max. terminal load (DC1 (IEC 947)) on 4-5, control card ..... 25 V DC, 2 A / 50 V DC, 1 A, 50 W  
 Max. terminal load (DC1) on 4-5, control card for UL/cUL applications ..... 30 V AC, 1 A / 42.5 V DC, 1A  
 Terminal nos., power card (resistive and inductive load) ..... 1-3 (break), 1-2 (make)  
 Max. terminal load (AC1) on 1-3, 1-2, power card ..... 250 V AC, 2 A, 500 VA  
 Max. terminal load (DC1 (IEC 947)) on 1-3, 1-2, power card ..... 25 V DC, 2 A / 50 V DC, 1A, 50 W  
 Min. terminal load (AC/DC) on 1-3, 1-2, power card ..... 24 V DC, 10 mA / 24 V AC, 100 mA

1) Rated values for up to 300,000 operations.

At inductive loads the number of operations are reduced by 50%, alternatively the current can be reduced by 50%, thus the 300,000 operations are maintained.

External 24 Volt DC supply (only available with VLT 6152-6602, 380-460 V):

Terminal nos. .... 35, 36  
 Voltage range ..... 24 V DC ±15% (max. 37 V DC for 10 sec.)  
 Max. voltage ripple ..... 2 V DC  
 Power consumption ..... 15 W - 50 W (50 W for start-up, 20 msec.)  
 Min. pre-fuse ..... 6 Amp  
*Reliable galvanic isolation: Full galvanic isolation if the external 24 V DC supply is also of the PELV type.*

Cable lengths and cross-sections:

Max. motor cable length, screened cable ..... 150 m  
 Max. motor cable length, unscreened cable ..... 300 m  
 Max. motor cable length, screened cable VLT 6011 380-460 V ..... 100 m  
 Max. motor cable length, screened cable VLT 6011 525-600 V ..... 50 m  
 Max. DC-bus cable length, screened cable ..... 25 m from frequency converter to DC bar.  
*Max. cable cross-section to motor, see next section*  
 Max. cross-section for 24 V external DC supply ..... 2.5 mm<sup>2</sup> /12 AWG  
 Max. cross-section for control cables ..... 1.5 mm<sup>2</sup> /16 AWG  
 Max. cross-section for serial communication ..... 1.5 mm<sup>2</sup> /16 AWG  
*If UL/cUL is to be complied with, copper cable with temperature class 60/75°C must be used*

(VLT 6002 - 6072 380 - 460 V, 525-600 V and VLT 6002 - 6032 200 - 240 V).

If UL/cUL is to be complied with, copper cable with temperature class 75°C must be used

(VLT 6042 - 6062 200 - 240 V, VLT 6102 - 6602 380 - 460 V, VLT 6102 - 6652 525 - 600 V).

Connectors are for use of both copper and aluminium cables, unless other is specified.

Control characteristics:

---

Frequency range .....	0 - 1000 Hz
Resolution on output frequency .....	±0.003 Hz
System response time .....	3 msec.
Speed, control range (open loop) .....	1:100 of synchro. speed
Speed, accuracy (open loop) .....	< 1500 rpm: max. error ± 7.5 rpm
>1500 rpm: max. error of 0.5% of actual speed	
Process, accuracy (closed loop) .....	< 1500 rpm: max. error ± 1.5 rpm
>1500 rpm: max. error of 0.1% of actual speed	

All control characteristics are based on a 4-pole asynchronous motor

Accuracy of display readout (parameters 009-012, Display readout):

---

Motor current [5] 0-140% load .....	Max. error: ±2.0% of rated output current
Power kW [6], Power HP [7], 0-90% load .....	Max. error: ±5% of rated output power

Externals:

---

Enclosure .....	IP 00, IP 20, IP 21/NEMA 1, IP 54
Vibration test .....	0.7 g RMS 18-1000 Hz random. 3 directions for 2 hours (IEC 68-2-34/35/36)
Max. relative humidity .....	93 % + 2 %, -3 % (IEC 68-2-3) for storage/transport
Max. relative humidity .....	95 % non condensing (IEC 721-3-3; class 3K3) for operation
Aggressive environment (IEC 721-3-3) .....	Uncoated class 3C2
Aggressive environment (IEC 721-3-3) .....	Coated class 3C3
Ambient temperature, VLT 6002-6005 200-240 V,	
6002-6011 380-460 V, 6002-6011 525-600 V Bookstyle, IP 20 .....	Max. 45°C (24-hour average max. 40°C)
Ambient temperature, VLT 6006-6062 200-240 V,	
6016-6602 380-460 V, 6016-6652 525-600 V IP 00, IP 20 .....	Max. 40°C (24-hour average max. 35°C)
Ambient temperature, VLT 6002-6062 200-240 V,	
6002-6602 380-460 V, VLT 6102-6652, 525-600 V, IP 54 .....	Max. 40°C (24-hour average max. 35°C)
Min. ambient temperature in full operation .....	0°C
Min. ambient temperature at reduced performance .....	-10°C
Temperature during storage/transport .....	-25 - +65/70°C
Max. altitude above sea level .....	1000 m
EMC standards applied, Emission .....	EN 61000-6-3/4, EN 61800-3, EN 55011, EN 55014
EMC standards applied, Immunity .....	EN 50082-2, EN

61000-4-2, IEC 1000-4-3, EN 61000-4-4, EN 61000-4-5, ENV 50204, EN 61000-4-6, VDE 0160/1990.12

*IP54 units are not intended for direct outdoor installation. The IP54 rating does not relate to other exposures as sun, icing, wind blown driving rain. Under such circumstances Danfoss recommends to install the units in an enclosure designed for these environmental conditions. Alternatively, an installation at minimum 0.5 m above surface and covered by a shed is recommended.*



**NB!:**

VLT 6002-6072, 525-600 V units do not comply with EMC, Low Voltage or PELV directives.

---

**VLT 6000 HVAC protection**

---

- Electronic motor thermal protection against overload.
- Temperature monitoring of heat-sink ensures that the frequency converter cuts out if the temperature reaches 90°C for IP00, IP20 and NEMA 1. For IP54, the cut-out temperature is 80°C. An overtemperature can only be reset when the temperature of the heat-sink has fallen below 60°C.

For the units mentioned below, the limits are as follows:

- VLT 6152, 380-460 V, cuts out at 75° C and can be reset if the temperature is below 60 °C.
- VLT 6172, 380-460 V, cuts out at 80° C and can be reset if the temperature has fallen below 60° C.
- VLT 6222, 380-460 V, cuts out at 95° C and can be reset if the temperature has fallen below 65° C.
- VLT 6272, 380-460 V, cuts out at 95° C and can be reset if the temperature has fallen below 65° C.
- VLT 6352, 380-460 V, cuts out at 105° C and can be reset if the temperature has fallen below 75° C.
- VLT 6402-6602, 380-460 V cuts out at 85° C and can be reset if the temperature has fallen below 60° C
- VLT 6102-6152, 525-600 V, cuts out at 75° C and can be reset if the temperature has fallen below 60° C.
- VLT 6172, 525-600 V, cuts out at 80° C and can be reset if the temperature has fallen below 60° C.
- VLT 6222-6402, 525-600 V, cuts out at 100° C and can be reset if the temperature has fallen below 70° C.
- VLT 6502-6652, 525-600 V, cuts out at 75° C and can be reset if the temperature has fallen below 60° C.

- The frequency converter is protected against short-circuiting on motor terminals U, V, W.
- The frequency converter is protected against earth fault on motor terminals U, V, W.
- Monitoring of the intermediate circuit voltage ensures that the frequency converter cuts out if the intermediate circuit voltage gets too high or too low.
- If a motor phase is missing, the frequency converter cuts out.
- If there is a mains fault, the frequency converter is able to carry out a controlled deceleration.
- If a mains phase is missing, the frequency converter will cut out or autoderate when a load is placed on the motor.

### ■ Technical data, mains supply 3 x 200-240V

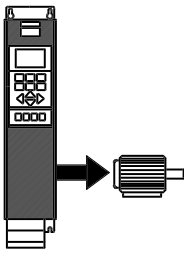
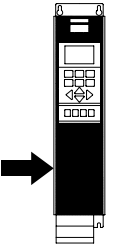
According to international requirements		VLT type	6002	6003	6004	6005	6006	6008	6011
	Output current <sup>4)</sup>	$I_{VLT,N}$ [A]	6.6	7.5	10.6	12.5	16.7	24.2	30.8
		$I_{VLT,MAX}$ (60 s) [A]	7.3	8.3	11.7	13.8	18.4	26.6	33.9
	Output power (240 V)	$S_{VLT,N}$ [kVA]	2.7	3.1	4.4	5.2	6.9	10.1	12.8
	Typical shaft output	$P_{VLT,N}$ [kW]	1.1	1.5	2.2	3.0	4.0	5.5	7.5
	Typical shaft output	$P_{VLT,N}$ [HP]	1.5	2	3	4	5	7.5	10
	Max. cable cross-section to motor and DC-bus	[mm <sup>2</sup> ]/[AWG]	4/10	4/10	4/10	4/10	10/8	16/6	16/6
	Max. input current	(200 V) (RMS) $I_{L,N}$ [A]	6.0	7.0	10.0	12.0	16.0	23.0	30.0
	Max. cable cross-section power	[mm <sup>2</sup> ]/[AWG] <sup>2)</sup>	4/10	4/10	4/10	4/10	4/10	16/6	16/6
	Max. pre-fuses	[-/UL <sup>1)</sup> ] [A]	16/10	16/15	25/20	25/25	35/30	50	60
	Efficiency <sup>3)</sup>		0.95	0.95	0.95	0.95	0.95	0.95	0.95
	Weight IP 20	[kg]	7	7	9	9	23	23	23
	Weight IP 54	[kg]	11.5	11.5	13.5	13.5	35	35	38
	Power loss at max. load. [W]	Total	76	95	126	172	194	426	545
	Enclosure	VLT type	IP 20 / IP 54						

1. For type of fuse, see section *Fuses*.

2. American Wire Gauge.

3. Measured using 30 m screened motor cables at rated load and rated frequency.

4. Current ratings fulfill UL requirements for 208-240 V.

### ■ Technical data, mains supply 3x200-240V

According to international requirements	VLT type	6016	6022	6027	6032	6042	6052	6062
Output current <sup>4)</sup>	$I_{VLT,N}$ [A] (200-230 V)	46.2	59.4	74.8	88.0	115	143	170
	$I_{VLT,MAX}$ (60 s) [A] (200-230 V)	50.6	65.3	82.3	96.8	127	158	187
	$I_{VLT,N}$ [A] (240 V)	46.0	59.4	74.8	88.0	104	130	154
	$I_{VLT,MAX}$ (60 s) [A] (240 V)	50.6	65.3	82.3	96.8	115	143	170
Output power	$S_{VLT,N}$ [kVA] (240 V)	19.1	24.7	31.1	36.6	43.2	54	64
	Typical shaft output	$P_{VLT,N}$ [kW]	11	15	18.5	22	30	37
Typical shaft output	$P_{VLT,N}$ [HP]	15	20	25	30	40	50	60
Max. cable cross-section to motor and DC-bus [mm <sup>2</sup> ]/[AWG] <sup>2) 5)</sup>	Copper	16/6	35/2	35/2	50/0	70/1/0	95/3/0	120/4/0
	Aluminium <sup>6)</sup>	16/6	35/2	35/2	50/0	95/3/0 <sup>5)</sup>	90/250 mcm <sup>5)</sup>	120/300 mcm <sup>5)</sup>
Min. cable cross-section to motor and DC-bus [mm <sup>2</sup> ]/[AWG] <sup>2)</sup>		10/8	10/8	10/8	16/6	10/8	10/8	10/8
Max. input current (200 V) (RMS) $I_{L,N}$ [A]		46.0	59.2	74.8	88.0	101.3	126.6	149.9
Max. cable cross-section power [mm <sup>2</sup> ]/[AWG] <sup>2) 5)</sup>	Copper	16/6	35/2	35/2	50/0	70/1/0	95/3/0	120/4/0
	Aluminium <sup>6)</sup>	16/6	35/2	35/2	50/0	95/3/0 <sup>5)</sup>	90/250 mcm <sup>5)</sup>	120/300 mcm <sup>5)</sup>
Max. pre-fuses [-]/UL <sup>1)</sup> [A]		60	80	125	125	150	200	250
Efficiency <sup>3)</sup>		0.95	0.95	0.95	0.95	0.95	0.95	0.95
Weight IP 00	[kg]	-	-	-	-	90	90	90
Weight IP 20/NEMA 1	[kg]	23	30	30	48	101	101	101
Weight IP 54	[kg]	38	49	50	55	104	104	104
Power loss at max. load.	[W]	545	783	1042	1243	1089	1361	1613
Enclosure		IP 00/IP 20/NEMA 1/IP 54						

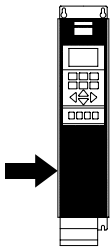
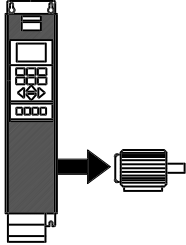

1. For type of fuse, see section *Fuses*.
2. American Wire Gauge.
3. Measured using 30 m screened motor cables at rated load and rated frequency.
4. Current ratings fulfill UL requirements for 208-240 V.
5. Connection stud 1 x M8 / 2 x M8.
6. Aluminium cables with cross section above 35 mm<sup>2</sup> must be connected by use of an Al-Cu connector.

**■ Technical data, mains supply 3 x 380-460V**

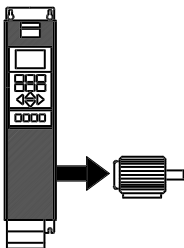
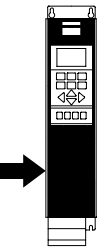
According to international requirements		VLT type	6002	6003	6004	6005	6006	6008	6011
 Output current	$I_{VLT,N}$ [A] (380-440 V)		3.0	4.1	5.6	7.2	10.0	13.0	16.0
	$I_{VLT,MAX}$ (60 s) [A] (380-440 V)		3.3	4.5	6.2	7.9	11.0	14.3	17.6
	$I_{VLT,N}$ [A] (441-460 V)		3.0	3.4	4.8	6.3	8.2	11.0	14.0
	$I_{VLT,MAX}$ (60 s) [A] (441-460 V)		3.3	3.7	5.3	6.9	9.0	12.1	15.4
 Output power	$S_{VLT,N}$ [kVA] (400 V)		2.2	2.9	4.0	5.2	7.2	9.3	11.5
	$S_{VLT,N}$ [kVA] (460 V)		2.4	2.7	3.8	5.0	6.5	8.8	11.2
Typical shaft output	$P_{VLT,N}$ [kW]		1.1	1.5	2.2	3.0	4.0	5.5	7.5
Typical shaft output	$P_{VLT,N}$ [HP]		1.5	2	3	-	5	7.5	10
Max. cable cross-section to motor	[mm <sup>2</sup> ]/[AWG] <sup>2) 4)</sup>		4/10	4/10	4/10	4/10	4/10	4/10	4/10
Max. input current (RMS)	$I_{L,N}$ [A] (380 V)		2.8	3.8	5.3	7.0	9.1	12.2	15.0
	$I_{L,N}$ [A] (460 V)		2.5	3.4	4.8	6.0	8.3	10.6	14.0
Max. cable cross-section power	[mm <sup>2</sup> ]/[AWG] <sup>2) 4)</sup>		4/10	4/10	4/10	4/10	4/10	4/10	4/10
Max. pre-fuses	[-]/UL <sup>1)</sup> [A]		16/6	16/10	16/10	16/15	25/20	25/25	35/30
Efficiency <sup>3)</sup>			0.96	0.96	0.96	0.96	0.96	0.96	0.96
Weight IP 20	[kg]		8	8	8.5	8.5	10.5	10.5	10.5
Weight IP 54	[kg]		11.5	11.5	12	12	14	14	14
Power loss at max. load. [W]	Total		67	92	110	139	198	250	295
Enclosure	VLT type	IP 20/IP 54							

1. For type of fuse, see section *Fuses*.
2. American Wire Gauge.
3. Measured using 30 m screened motor cables at rated load and rated frequency.
4. Max. cable cross section is the maximum possible cable cross section that can be fitted on the terminals. Always comply with national and local regulations on min. cable cross-section.

### ■ Technical data, mains supply 3x380-460V

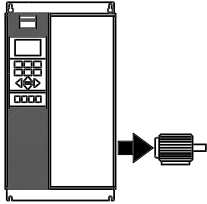
According to international requirements		VLT type	6016	6022	6027	6032	6042
	Output current	$I_{VLT,N}$ [A] (380-440 V)	24.0	32.0	37.5	44.0	61.0
		$I_{VLT,MAX}$ (60 s) [A] (380-440 V)	26.4	35.2	41.3	48.4	67.1
	Output power	$I_{VLT,N}$ [A] (441-460 V)	21.0	27.0	34.0	40.0	52.0
		$I_{VLT,MAX}$ (60 s) [A] (441-460 V)	23.1	29.7	37.4	44.0	57.2
	Typical shaft output	$S_{VLT,N}$ [kVA] (400 V)	17.3	23.0	27.0	31.6	43.8
		$S_{VLT,N}$ [kVA] (460 V)	16.7	21.5	27.1	31.9	41.4
Typical shaft output	$P_{VLT,N}$ [kW]	11	15	18.5	22	30	
Typical shaft output	$P_{VLT,N}$ [HP]	15	20	25	30	40	
Max. cable cross-section to motor and DC-bus, IP 20	[mm <sup>2</sup> ]/[AWG] <sup>2) 4)</sup>		16/6	16/6	16/6	35/2	35/2
Max. cable cross-section to motor and DC-bus, IP 54			16/6	16/6	16/6	16/6	35/2
Min. cable cross-section to motor and DC-bus	[mm <sup>2</sup> ]/[AWG] <sup>2) 4)</sup>	10/8	10/8	10/8	10/8	10/8	
Max. input current (RMS)	$I_{L,N}$ [A] (380 V)	24.0	32.0	37.5	44.0	60.0	
	$I_{L,N}$ [A] (460 V)	21.0	27.6	34.0	41.0	53.0	
Max. cable cross-section power, IP 20	[mm <sup>2</sup> ]/[AWG] <sup>2) 4)</sup>		16/6	16/6	16/6	35/2	35/2
Max. cable cross-section power, IP 54			16/6	16/6	16/6	16/6	35/2
Max. pre-fuses	[ ]/UL <sup>1)</sup> [A]	63/40	63/40	63/50	63/60	80/80	
Efficiency at rated frequency		0.96	0.96	0.96	0.96	0.96	
Weight IP 20	[kg]	21	21	22	27	28	
Weight IP 54	[kg]	41	41	42	42	54	
Power loss at max. load.	[W]	419	559	655	768	1065	
Enclosure		IP 20/ IP 54					

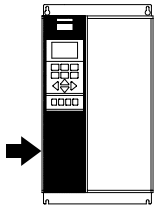

1. For type of fuse, see section *Fuses*.
2. American Wire Gauge.
3. Measured using 30 m screened motor cables at rated load and rated frequency.
4. Min. cable cross-section is the smallest cable cross-section allowed to be fitted on the terminals. Max. cable cross section is the maximum possible cable cross section that can be fitted on the terminals.  
Always comply with national and local regulations on min. cable cross-section.

### ■ Technical data, mains supply 3x380-460V

According to international requirements		VLT type	6052	6062	6072	6102	6122	
Output current	$I_{VLT,N}$ [A] (380-440 V)		73.0	90.0	106	147	177	
	$I_{VLT, MAX}$ (60 s) [A] (380-440 V)		80.3	99.0	117	162	195	
	$I_{VLT,N}$ [A] (441-460 V)		65.0	77.0	106	130	160	
	$I_{VLT, MAX}$ (60 s) [A] (441-460 V)		71.5	84.7	117	143	176	
Output power	$S_{VLT,N}$ [kVA] (400 V)		52.5	64.7	73.4	102	123	
	$S_{VLT,N}$ [kVA] (460 V)		51.8	61.3	84.5	104	127	
Typical shaft output	$P_{VLT,N}$ [kW]		37	45	55	75	90	
Typical shaft output	$P_{VLT,N}$ [HP]		50	60	75	100	125	
Max. cable cross-section to motor and DC-bus, IP 20	$[mm^2]/[AWG]^2$ 4) 6)		35/2	50/0	50/0	120 / 250	120 / 250	
						mcm <sup>5)</sup>	mcm <sup>5)</sup>	
Max. cable cross-section to motor and DC-bus, IP 54	$[mm^2]/[AWG]^2$ 4) 6)		35/2	50/0	50/0	150 / 300	150 / 300	
						mcm <sup>5)</sup>	mcm <sup>5)</sup>	
Min. cable cross-section to motor and DC-bus	$[mm^2]/[AWG]^2$ 4)		10/8	16/6	16/6	25/4	25/4	
Max. input current (RMS)	$I_{L,N}$ [A] (380 V)		72.0	89.0	104	145	174	
	$I_{L,N}$ [A] (460 V)		64.0	77.0	104	128	158	
Max. cable cross-section power, IP 20	$[mm^2]/[AWG]^2$ 4) 6)		35/2	50/0	50/0	120 / 250	120 / 250	
						mcm	mcm	
Max. cable cross-section power, IP 54	$[mm^2]/[AWG]^2$ 4) 6)		35/2	50/0	50/0	150 / 300	150 / 300	
						mcm	mcm	
Max. pre-fuses	$[-]/[UL^1)$ [A]		100/100	125/125	150/150	225/225	250/250	
Efficiency at rated frequency			0.96	0.96	0.96	0.98	0.98	
Weight IP 20	[kg]		41	42	43	54	54	
Weight IP 54	[kg]		56	56	60	77	77	
Power loss at max. load.	[W]		1275	1571	1322	1467	1766	
Enclosure							IP 20/IP 54	

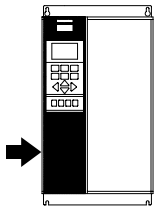
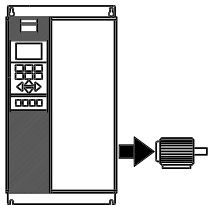

1. For type of fuse, see section *Fuses*.
2. American Wire Gauge.
3. Measured using 30 m screened motor cables at rated load and rated frequency.
4. Min. cable cross-section is the smallest cable cross-section allowed to be fitted on the terminals. Max. cable cross section is the maximum possible cable cross section that can be fitted on the terminals.  
Always comply with national and local regulations on min. cable cross-section.
5. DC connection 95 mm<sup>2</sup>/AWG 3/0.
6. Aluminium cables with cross-section above 35 mm<sup>2</sup> must be connected by use of an Al-Cu connector.

### ■ Technical data, mains supply 3x380-460V

According to international requirements		VLT type	6152	6172	6222	6272	6352
Output current	$I_{VLT,N}$ [A] (380-440 V)		212	260	315	395	480
	$I_{VLT, MAX}$ (60 s) [A] (380-440 V)		233	286	347	435	528
	$I_{VLT,N}$ [A] (441-460 V)		190	240	302	361	443
	$I_{VLT, MAX}$ (60 s) [A] (441-460 V)		209	264	332	397	487
Output power	$S_{VLT,N}$ [kVA] (400 V)		147	180	218	274	333
	$S_{VLT,N}$ [kVA] (460 V)		151	191	241	288	353
Typical shaft output (380-440 V) $P_{VLT,N}$ [kW]			110	132	160	200	250
Typical shaft output (441-460 V) $P_{VLT,N}$ [HP]			150	200	250	300	350
Max. cable cross-section to motor and DC-bus [mm <sup>2</sup> ] <sup>2) 4) 5)</sup>			2x70	2x70	2x185	2x185	2x185
Max. cable cross-section to motor and DC-bus [AWG] <sup>2) 4) 5)</sup>			2x2/0	2x2/0	2x350	2x350	2x350
Min. cable cross-section to motor and DC-bus [mm <sup>2</sup> /AWG] <sup>2) 4) 5)</sup>			35/2	35/2	35/2	35/2	35/2
Max. input current (RMS)	$I_{L,N}$ [A] (380 V)		208	256	317	385	467
	$I_{L,N}$ [A] (460 V)		185	236	304	356	431
Max. cable cross-section to power [mm <sup>2</sup> ] <sup>2) 4) 5)</sup>			2x70	2x70	2x185	2x185	2x185
Max. cable cross-section to power [AWG] <sup>2) 4) 5)</sup>			2x2/0	2x2/0	2x350	2x350	2x350
Max. pre-fuses [-]/UL <sup>1)</sup> [A]			300/300	350/350	450/400	500/500	630/600
Weight IP 00	[kg]		82	91	112	123	138
Weight IP 20	[kg]		96	104	125	136	151
Weight IP 54	[kg]		96	104	125	136	151
Efficiency at rated frequency			0.98				
Power loss at max. load.	[W]		2619	3309	4163	4977	6107
Enclosure			IP 00/IP 21/NEMA 1/IP 54				

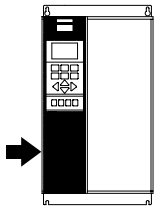
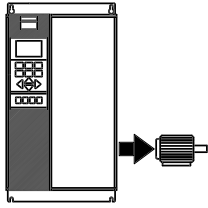

1. For type of fuse, see section *Fuses*.
2. American Wire Gauge.
3. Measured using 30 m screened motor cables at rated load and rated frequency.
4. Min. cable cross-section is the smallest cable cross-section allowed to be fitted on the terminals. Max. cable cross section is the maximum possible cable cross section that can be fitted on the terminals.  
Always comply with national and local regulations on min. cable cross-section.
5. Connection bolt 1 x M10 / 2 x M10 (mains and motor), connection bolt 1 x M8 / 2 x M8 (DC-bus).

### ■ Technical data, mains supply 3 x 380-460 V

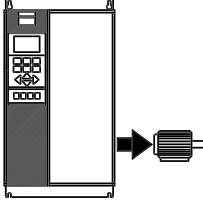
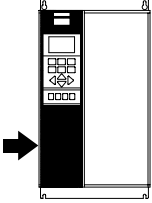
According to international requirements	VLT type					
	6402	6502	6552	6602		
	Output current	$I_{VLT,N}$ [A] (380-440 V)	600	658	745	800
		$I_{VLT,MAX}$ (60 s) [A] (380-440 V)	660	724	820	880
		$I_{VLT,N}$ [A] (441-460 V)	540	590	678	730
		$I_{VLT,MAX}$ (60 s) [A] (441-460 V)	594	649	746	803
	Output power	$S_{VLT,N}$ [kVA] (400 V)	416	456	516	554
		$S_{VLT,N}$ [kVA] (460 V)	430	470	540	582
	Typical shaft output (380-440 V) $P_{VLT,N}$ [kW]		315	355	400	450
	Typical shaft output (441-460 V) $P_{VLT,N}$ [HP]		450	500	550/600	600
Max. cable cross-section to motor and DC-bus		4 x 240	4 x 240	4 x 240	4 x 240	4 x 240
[mm <sup>2</sup> ] <sup>4) 5)</sup>						
Max. cable cross-section to motor and DC-bus		4 x 500 mcm	4 x 500 mcm	4 x 500 mcm	4 x 500 mcm	4 x 500 mcm
[AWG] <sup>2) 4) 5)</sup>						
Max. input current (RMS)	$I_{L,MAX}$ [A] (380 V)	584	648	734	787	
	$I_{L,MAX}$ [A] (460 V)	526	581	668	718	
Max. cable cross-section to power	[mm <sup>2</sup> ] <sup>4) 5)</sup>	4 x 240	4 x 240	4 x 240	4 x 240	4 x 240
Max. cable cross-section to power	[AWG] <sup>2) 4) 5)</sup>	4 x 500 mcm	4 x 500 mcm	4 x 500 mcm	4 x 500 mcm	4 x 500 mcm
Max. pre-fuses (mains)	[-/UL] [A] <sup>1)</sup>	700/700	900/900	900/900	900/900	
Efficiency <sup>3)</sup>		0.98	0.98	0.98	0.98	
Weight IP 00	[kg]	221	234	236	277	
Weight IP 20	[kg]	263	270	272	313	
Weight IP 54	[kg]	263	270	272	313	
Power loss at max. load	[W]	7630	7701	8879	9428	
Enclosure		IP 00 / IP 21/NEMA 1 / IP 54				

1. For type of fuse, see section *Fuses*.
2. American Wire Gauge.
3. Measured using 30 m screened motor cables at rated load and rated frequency.
4. Always comply with national and local regulations on min. cable cross-section. Max. cable cross section is the maximum possible cable cross section that can be fitted on the terminals.
5. Connection bolt power supply, motor and load sharing: M10 compression (lug), 2 x M8 (box lug)

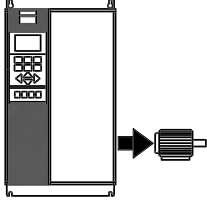

### ■ Technical data, mains supply 3 x 525-600 V

According to international requirements		VLT type	6002	6003	6004	6005	6006	6008	6011	
	Output current $I_{VLT,N}$ [A] (550 V)		2.6	2.9	4.1	5.2	6.4	9.5	11.5	
	$I_{VLT,MAX}$ (60 s) [A] (550V)		2.9	3.2	4.5	5.7	7.0	10.5	12.7	
	$I_{VLT,N}$ [A] (575 V)		2.4	2.7	3.9	4.9	6.1	9.0	11.0	
	$I_{VLT,MAX}$ (60 s) [A] (575 V)		2.6	3.0	4.3	5.4	6.7	9.9	12.1	
	Output S $S_{VLT,N}$ [kVA] (550 V)		2.5	2.8	3.9	5.0	6.1	9.0	11.0	
	$S_{VLT,N}$ [kVA] (575 V)		2.4	2.7	3.9	4.9	6.1	9.0	11.0	
	Typical shaft output $P_{VLT,N}$ [kW]		1.1	1.5	2.2	3	4	5.5	7.5	
	Typical shaft output $P_{VLT,N}$ [HP]		1.5	2	3	4	5	7.5	10	
	Max. copper cable cross-section to motor and loadsharing									
		[mm <sup>2</sup> ]	4	4	4	4	4	4	4	4
	[AWG] <sup>2)</sup>	10	10	10	10	10	10	10	10	
Rated Input	$I_{VLT,N}$ [A] (550 V)	2.5	2.8	4.0	5.1	6.2	9.2	11.2		
Current	$I_{VLT,N}$ [A] (600 V)	2.2	2.5	3.6	4.6	5.7	8.4	10.3		
Max.copper cable cross-section, power										
	[mm <sup>2</sup> ]	4	4	4	4	4	4	4	4	
	[AWG] <sup>2)</sup>	10	10	10	10	10	10	10	10	
Max. prefuses (mains) <sup>1)</sup> [ - ]/UL [A]		3	4	5	6	8	10	15		
Efficiency		0.96								
Weight IP20	[kg]	10.5	10.5	10.5	10.5	10.5	10.5	10.5	10.5	
/ NEMA 1	[lbs]	23	23	23	23	23	23	23	23	
Estimated power loss at max. load (550 V) [W]		65	73	103	131	161	238	288		
Estimated power loss at max. load (600V) [W]		63	71	102	129	160	236	288		
Enclosure		IP 20/NEMA 1								

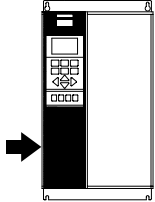

1. For type of fuse, see section *Fuses*.
2. American Wire Gauge (AWG).
3. Min. cable cross-section is the smallest cable cross-section allowed to be fitted into the terminals to comply with IP20. Always comply with national and local regulations on min. cable cross-section.

### ■ Technical data, mains supply 3 x 525-600 V

According to international requirements		6016	6022	6027	6032	6042	6052	6062	6072
Output current $I_{VLT,N}$ [A] (550 V)		18	23	28	34	43	54	65	81
$I_{VLT,MAX}$ (60 s) [A] (550V)		20	25	31	37	47	59	72	89
$I_{VLT,N}$ [A] (575 V)		17	22	27	32	41	52	62	77
$I_{VLT,MAX}$ (60 s) [A] (575 V)		19	24	30	35	45	57	68	85
Output	$S_{VLT,N}$ [kVA] (550 V)	17	22	27	32	41	51	62	77
	$S_{VLT,N}$ [kVA] (575 V)	17	22	27	32	41	52	62	77
Typical shaft output $P_{VLT,N}$ [kW]		11	15	18.5	22	30	37	45	55
Typical shaft output $P_{VLT,N}$ [HP]		15	20	25	30	40	50	60	75
Max. copper cable cross-section to motor and loadsharing <sup>4)</sup>	[mm <sup>2</sup> ]	16	16	16	35	35	50	50	50
	[AWG] <sup>2)</sup>	6	6	6	2	2	1/0	1/0	1/0
Min. cable cross-section to motor and loadsharing <sup>3)</sup>	[mm <sup>2</sup> ]	0.5	0.5	0.5	10	10	16	16	16
	[AWG] <sup>2)</sup>	20	20	20	8	8	6	6	6
Rated Input Current									
$I_{VLT,N}$ [A] (550 V)		18	22	27	33	42	53	63	79
$I_{VLT,N}$ [A] (600 V)		16	21	25	30	38	49	38	72
Max copper cable cross section, power <sup>4)</sup>	[mm <sup>2</sup> ]	16	16	16	35	35	50	50	50
	[AWG] <sup>2)</sup>	6	6	6	2	2	1/0	1/0	1/0
Max. prefuses (mains) <sup>1)</sup> /UL [A]		20	30	35	45	60	75	90	100
Efficiency		0.96							
Weight IP20 / NEMA 1	[kg]	23	23	23	30	30	48	48	48
	[lbs]	51	51	51	66	66	106	106	106
Estimated power loss at max. load (550 V) [W]		451	576	702	852	1077	1353	1628	2029
Estimated power loss at max. load (600 V) [W]		446	576	707	838	1074	1362	1624	2016
Enclosure		NEMA 1							

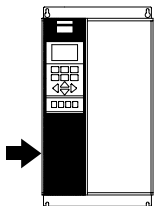
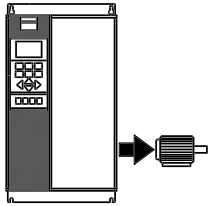

1. For type of fuse, see section *Fuses*.
2. American Wire Gauge (AWG).
3. Min. cable cross-section is the smallest cable cross-section allowed to be fitted into the terminals to comply with IP20.  
Always comply with national and local regulations on min. cable cross-section.
4. Aluminium cables with cross-section above 35 mm<sup>2</sup> must be connected by use of an Al-Cu connector.

### ■ Mains supply 3 x 525-600 V

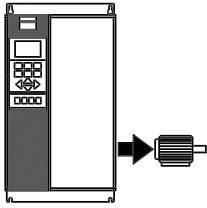
According to international requirements		VLT type	6102	6122
	Output current	$I_{VLT,N}$ [A] (525-550 V)	113	137
		$I_{VLT,MAX}$ (60 s) [A] (525-550 V)	124	151
	Output	$I_{VLT,N}$ [A] (551-600 V)	108	131
		$I_{VLT,MAX}$ (60 s) [A] (551-600 V)	119	144
Typical shaft output	$S_{VLT,N}$ [kVA] (550 V)	108	131	
	$S_{VLT,N}$ [kVA] (575 V)	108	130	
Max. cable cross-section to motor	[kW] (550 V)	75	90	
	[HP] (575 V)	100	125	
Max. cable cross-section to loadsharing and brake	[mm <sup>2</sup> ] <sup>4,5</sup>	2 x 70		
	[AWG] <sup>2,4,5</sup>	2 x 2/0		
Rated input current	$I_{L,N}$ [A] (550 V)	110	130	
	$I_{L,N}$ [A] (575 V)	106	124	
	$I_{L,N}$ [A] (690 V)	109	128	
Max. cable cross-section power supply	[mm <sup>2</sup> ] <sup>4,5</sup>	2 x 70		
	[AWG] <sup>2,4,5</sup>	2 x 2/0		
Min. cable cross-section to motor and power supply	[mm <sup>2</sup> ] <sup>4,5</sup>	35		
	[AWG] <sup>2,4,5</sup>	2		
Min. cable cross-section to brake and loadsharing	[mm <sup>2</sup> ] <sup>4,5</sup>	10		
	[AWG] <sup>2,4,5</sup>	8		
Max. pre-fuses (mains) [-]/UL	[A] <sup>1</sup>	200	250	
Efficiency <sup>3</sup>			0.98	
Power loss [W]		2156	2532	
Weight	IP 00 [kg]		82	
	IP 21/Nema1 [kg]		96	
	IP 54/Nema12 [kg]		96	
Enclosure		IP 00, IP 21/Nema 1 and IP 54/Nema12		

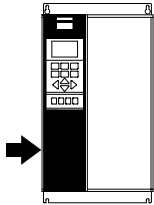

1. For type of fuse see section *Fuses*
2. American Wire Gauge.
3. Measured using 30 m screened motor cables at rated load and rated frequency.
4. Max. cable cross-section is the maximum possible cable cross-section allowed to be fitted on the terminals. Min. cable cross-section is the minimum allowed cross-section. Always comply with national and local regulations on min. cable cross-section.
5. Connection bolt 1 x M10 / 2 x M10 (mains and motor), connection bolt 1 x M8 / 2 x M8 (DC-bus).

### ■ Mains supply 3 x 525-600 V

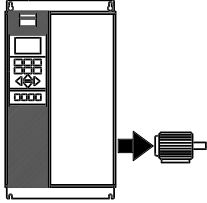
According to international requirements		VLT type	6152	6172	6222	6272	6352	6402
	Output current	$I_{VLT,N}$ [A] (525-550 V)	162	201	253	303	360	418
		$I_{VLT, MAX}$ (60 s) [A] (525-550 V)	178	221	278	333	396	460
		$I_{VLT,N}$ [A] (551-600 V)	155	192	242	290	344	400
		$I_{VLT, MAX}$ (60 s) [A] (551-600 V)	171	211	266	319	378	440
	Output	$S_{VLT,N}$ [kVA] (550 V)	154	191	241	289	343	398
		$S_{VLT,N}$ [kVA] (575 V)	154	191	241	289	343	398
Typical shaft output	[kW] (550 V)	110	132	160	200	250	315	
	[HP] (575 V)	150	200	250	300	350	400	
Max. cable cross-section to motor	[mm <sup>2</sup> ] <sup>4,5</sup>	2 x 70		2 x 185				
	[AWG] <sup>2,4,5</sup>	2 x 2/0		2 x 350 mcm				
Max. cable cross-section to loadsharing and brake	[mm <sup>2</sup> ] <sup>4,5</sup>	2 x 70		2 x 185				
	[AWG] <sup>2,4,5</sup>	2 x 2/0		2 x 350 mcm				
Rated input current	$I_{L,N}$ [A] (550 V)	158	198	245	299	355	408	
	$I_{L,N}$ [A] (575 V)	151	189	234	286	339	390	
	$I_{L,N}$ [A] (690 V)	155	197	240	296	352	400	
Max. cable cross-section power supply	[mm <sup>2</sup> ] <sup>4,5</sup>	2 x 70		2 x 185				
	[AWG] <sup>2,4,5</sup>	2 x 2/0		2 x 350 mcm				
Min. cable cross-section to motor and power supply	[mm <sup>2</sup> ] <sup>4,5</sup>					35		
	[AWG] <sup>2,4,5</sup>					2		
Min. cable cross-section to brake and loadsharing	[mm <sup>2</sup> ] <sup>4,5</sup>					10		
	[AWG] <sup>2,4,5</sup>					8		
Max. pre-fuses (mains)	[A] <sup>1</sup>	315	350	350	400	500	550	
[-]/UL								
Efficiency <sup>3</sup>		0,98						
Power loss [W]		2963	3430	4051	4867	5493	5852	
Weight	IP 00 [kg]	82	91	112	123	138	151	
Weight	IP 21/Nema1 [kg]	96	104	125	136	151	165	
Weight	IP 54/Nema12 [kg]	96	104	125	136	151	165	
Enclosure		IP 00, IP 21/Nema 1 and IP 54/Nema12						

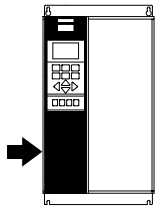

1. For type of fuse see section *Fuses*
2. American Wire Gauge.
3. Measured using 30 m screened motor cables at rated load and rated frequency.
4. Max. cable cross-section is the maximum possible cable cross-section allowed to be fitted on the terminals. Min. cable cross-section is the minimum allowed cross-section. Always comply with national and local regulations on min. cable cross-section.
5. Connection bolt 1 x M10 / 2 x M10 (mains and motor), connection bolt 1 x M8 / 2 x M8 (DC-bus).

### ■ Technical data, mains supply 3 x 525-600 V

According to international requirements	VLT type	6502	6602	6652
Output current	$I_{VLT,N}$ [A] (525-550 V)	523	596	630
	$I_{VLT,MAX}$ (60 s) [A] (525-550 V)	757	656	693
	$I_{VLT,N}$ [A] (551-600 V)	500	570	630
	$I_{VLT,MAX}$ (60 s) [A] (551-600 V)	550	627	693
Output power	$S_{VLT,N}$ [kVA] (550 V)	498	568	600
	$S_{VLT,N}$ [kVA] (575 V)	498	568	627
Typical shaft output (525-550 V) $P_{VLT,N}$ [kW]		400	450	500
Typical shaft output (551-600 V) $P_{VLT,N}$ [HP]		500	600	650
Max. cable cross-section to motor and DC-bus [mm <sup>2</sup> ] <sup>4) 5)</sup>		4 x 240	4 x 240	4 x 240
Max. cable cross-section to motor and DC-bus [AWG] <sup>2)</sup>		4 x 500 mcm	4 x 500 mcm	4 x 500 mcm
<hr/>				
Max. input current (RMS)	$I_{L,MAX}$ [A] (550 V)	504	574	607
	$I_{L,MAX}$ [A] (575 V)	482	549	607
Max. cable cross-section to power [mm <sup>2</sup> ] <sup>4) 5)</sup>		4 x 240	4 x 240	4 x 240
Max. cable cross-section to power [AWG] <sup>2) 4) 5)</sup>		4 x 500 mcm	4 x 500 mcm	4 x 500 mcm
Max. pre-fuses (mains)	[-/UL [A] <sup>1)</sup>	700/700	900/900	900/900
Efficiency <sup>3)</sup>		0.98	0.98	0.98
Weight IP 00	[kg]	221	236	277
Weight IP 20	[kg]	263	272	313
Weight IP 54	[kg]	263	272	313
Power loss at max. load	[W]	6903	8343	9240
Enclosure		IP 00 / IP 21/NEMA 1 / IP 54		

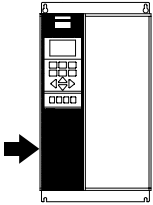
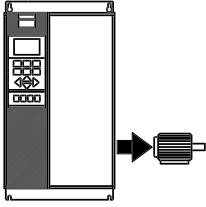

1. For type of fuse, see section *Fuses*.
2. American Wire Gauge.
3. Measured using 30 m screened motor cables at rated load and rated frequency.
4. Always comply with national and local regulations on min. cable cross-section. Max. cable cross section is the maximum possible cable cross section that can be fitted on the terminals.
5. Connection bolt power supply, motor and load sharing: M10 (compression lug), 2 x M8 (box lug)

**■ Fuses**
**UL compliance**

To comply with UL/cUL approvals, pre-fuses according to the table below must be used.

**200-240 V**

VLT	Bussmann	SIBA	Littel fuse	Ferraz-Shawmut
6002	KTN-R10	5017906-010	KLN-R10	ATM-R10 or A2K-10R
6003	KTN-R15	5017906-016	KLN-R15	ATM-R15 or A2K-15R
6004	KTN-R20	5017906-020	KLN-R20	ATM-R20 or A2K-20R
6005	KTN-R25	5017906-025	KLN-R25	ATM-R25 or A2K-25R
6006	KTN-R30	5017906-032	KLN-R30	ATM-R30 or A2K-30R
6008	KTN-R50	5012406-050	KLN-R50	A2K-50R
6011, 6016	KTN-R60	5014006-063	KLN-R60	A2K-60R
6022	KTN-R80	5014006-080	KLN-R80	A2K-80R
6027, 6032	KTN-R125	2028220-125	KLN-R125	A2K-125R
6042	FWX-150	2028220-150	L25S-150	A25X-150
6052	FWX-200	2028220-200	L25S-200	A25X-200
6062	FWX-250	2028220-250	L25S-250	A25X-250

**380-460 V**

	Bussmann	SIBA	Littel fuse	Ferraz-Shawmut
6002	KTS-R6	5017906-006	KLS-R6	ATM-R6 or A6K-6R
6003, 6004	KTS-R10	5017906-010	KLS-R10	ATM-R10 or A6K-10R
6005	KTS-R15	5017906-016	KLS-R16	ATM-R16 or A6K-16R
6006	KTS-R20	5017906-020	KLS-R20	ATM-R20 or A6K-20R
6008	KTS-R25	5017906-025	KLS-R25	ATM-R25 or A6K-25R
6011	KTS-R30	5012406-032	KLS-R30	ATM-R30 or A6K-30R
6016, 6022	KTS-R40	5014006-040	KLS-R40	A6K-40R
6027	KTS-R50	5014006-050	KLS-R50	A6K-50R
6032	KTS-R60	5014006-063	KLS-R60	A6K-60R
6042	KTS-R80	2028220-100	KLS-R80	A6K-80R
6052	KTS-R100	2028220-125	KLS-R100	A6K-100R
6062	KTS-R125	2028220-125	KLS-R125	A6K-125R
6072	KTS-R150	2028220-160	KLS-R150	A6K-150R
6102	FWH-220	2028220-200	L50S-225	A50-P225
6122	FWH-250	2028220-250	L50S-250	A50-P250
6152*	FWH-300/170M3017	2028220-315	L50S-300	A50-P300
6172*	FWH-350/170M3018	2028220-315	L50S-350	A50-P350
6222*	FWH-400/170M4012	206xx32-400	L50S-400	A50-P400
6272*	FWH-500/170M4014	206xx32-500	L50S-500	A50-P500
6352*	FWH-600/170M4016	206xx32-600	L50S-600	A50-P600
6402	170M4017	2061032-700		6,9URD31D08A0700
6502	170M6013	2063032-900		6,9URD33D08A0900
6552	170M6013	2063032-900		6,9URD33D08A0900
6602	170M6013	2063032-900		6,9URD33D08A0900

\* Circuit Breakers manufactured by General Electric, Cat .No. SKHA36AT0800, with the rating plugs listed below can be used to meet UL requirement.

6152	rating plug No.	SRPK800 A 300
6172	rating plug No.	SRPK800 A 400
6222	rating plug No.	SRPK800 A 400
6272	rating plug No.	SRPK800 A 500
6352	rating plug No.	SRPK800 A 600

**525-600 V**

	Bussmann	SIBA	Littel fuse	Ferraz-Shawmut
6002	KTS-R3	5017906-004	KLS-R003	A6K-3R
6003	KTS-R4	5017906-004	KLS-R004	A6K-4R
6004	KTS-R5	5017906-005	KLS-R005	A6K-5R
6005	KTS-R6	5017906-006	KLS-R006	A6K-6R
6006	KTS-R8	5017906-008	KLS-R008	A6K-8R
6008	KTS-R10	5017906-010	KLS-R010	A6K-10R
6011	KTS-R15	5017906-016	KLS-R015	A6K-15R
6016	KTS-R20	5017906-020	KLS-R020	A6K-20R
6022	KTS-R30	5017906-030	KLS-R030	A6K-30R
6027	KTS-R35	5014006-040	KLS-R035	A6K-35R
6032	KTS-R45	5014006-050	KLS-R045	A6K-45R
6042	KTS-R60	5014006-063	KLS-R060	A6K-60R
6052	KTS-R75	5014006-080	KLS-R075	A6K-80R
6062	KTS-R90	5014006-100	KLS-R090	A6K-90R
6072	KTS-R100	5014006-100	KLS-R100	A6K-100R

**525-600 V**

	Bussmann	SIBA	FERRAZ-SHAWMUT
6102	170M3015	2061032,2	6.6URD30D08A0200
6122	170M3016	2061032,25	6.6URD30D08A0250
6152	170M3017	2061032,315	6.6URD30D08A0315
6172	170M3018	2061032,35	6.6URD30D08A0350
6222	170M4011	2061032,35	6.6URD30D08A0350
6272	170M4012	2061032,4	6.6URD30D08A0400
6352	170M4014	2061032,5	6.6URD30D08A0500
6402	170M5011	2062032,55	6.6URD32D08A550
6502	170M4017	2061032,700	6,9URD31D08A0700
6602	170M6013	2063032,900	6,9URD33D08A0900
6652	170M6013	2063032,900	6,9URD33D08A0900

KTS-fuses from Bussmann may substitute KTN for 240 V drives.  
 FWH-fuses from Bussmann may substitute FWX for 240 V drives.

KLSR fuses from LITTEL FUSE may substitute KLNR fuses for 240 V drives.  
 L50S fuses from LITTEL FUSE may substitute L25S fuses for 240 V drives.

A6KR fuses from FERRAZ SHAWMUT may substitute A2KR for 240 V drives.  
 A50X fuses from FERRAZ SHAWMUT may substitute A25X for 240 V drives.

**Non UL compliance**

If UL/cUL is not to be complied with, we recommend the above mentioned fuses or:

VLT 6002-6032	200-240 V	type gG
VLT 6042-6062	200-240 V	type gR
VLT 6002-6072	380-460 V	type gG
VLT 6102-6122	380-460 V	type gR
VLT 6152-6352	380-460 V	type gG
VLT 6402-6602	380-460 V	type gR
VLT 6002-6072	525-600 V	type gG

Not following the recommendation may result in damage of the drive in case of malfunction. Fuses must be designed for protection in a circuit capable of supplying a maximum of 100000 A<sub>rms</sub> (symmetrical), 500 V / 600 V maximum.



**■ Mechanical dimensions**

All the below listed measurements are in mm.

VLT type	A	B	C	a	b	aa/bb	Type	
<b>Bookstyle IP 20 200 - 240 V</b>								
6002 - 6003	395	90	260	384	70	100	A	
6004 - 6005	395	130	260	384	70	100	A	
<b>Bookstyle IP 20 380 - 460 V</b>								
6002 - 6005	395	90	260	384	70	100	A	
6006 - 6011	395	130	260	384	70	100	A	
<b>IP 00 200 - 240 V</b>								
6042 - 6062	800	370	335	780	270	225	B	
<b>IP 00 380 - 460 V</b>								
6152 - 6172	1046	408	373 <sup>1)</sup>	1001	304	225	J	
6222 - 6352	1327	408	373 <sup>1)</sup>	1282	304	225	J	
6402 - 6602	1547	585	494 <sup>1)</sup>	1502	304	225	J	
<b>IP 20 200 - 240 V</b>								
6002 - 6003	395	220	160	384	200	100	C	
6004 - 6005	395	220	200	384	200	100	C	
6006 - 6011	560	242	260	540	200	200	D	
6016 - 6022	700	242	260	680	200	200	D	
6027 - 6032	800	308	296	780	270	200	D	
6042 - 6062	954	370	335	780	270	225	E	
<b>IP 20 380 - 460 V</b>								
6002 - 6005	395	220	160	384	200	100	C	
6006 - 6011	395	220	200	384	200	100	C	
6016 - 6027	560	242	260	540	200	200	D	
6032 - 6042	700	242	260	680	200	200	D	
6052 - 6072	800	308	296	780	270	200	D	
6102 - 6122	800	370	335	780	330	225	D	
<b>IP 21/NEMA 1 380-460 V</b>								
6152 - 6172	1208	420	373 <sup>1)</sup>	1154	304	225	J	
6222 - 6352	1588	420	373 <sup>1)</sup>	1535	304	225	J	
6402 - 6602	2000	600	494 <sup>1)</sup>	-	-	225	H	
<b>IP 54 200 - 240 V</b>								
6002 - 6003	460	282	195	85	260	258	100	F
6004 - 6005	530	282	195	85	330	258	100	F
6006 - 6011	810	350	280	70	560	326	200	F
6016 - 6032	940	400	280	70	690	375	200	F
6042 - 6062	937	495	421	-	830	374	225	G
<b>IP 54 380 - 460 V</b>								
6002 - 6005	460	282	195	85	260	258	100	F
6006 - 6011	530	282	195	85	330	258	100	F
6016 - 6032	810	350	280	70	560	326	200	F
6042 - 6072	940	400	280	70	690	375	200	F
6102 - 6122	940	400	360	70	690	375	225	F
6152 - 6172	1208	420	373 <sup>1)</sup>	-	1154	304	225	J
6222 - 6352	1588	420	373 <sup>1)</sup>	-	1535	304	225	J
6402 - 6602	2000	600	494 <sup>1)</sup>	-	-	-	225	H

Installation

1. With disconnect add 44 mm.

aa: Minimum space above enclosure

bb: Minimum space below enclosure

**■ Mechanical dimensions**

All the below listed measurements are in mm.

VLT Type	A	B	C	a	b	aa/bb	Type
<b>IP 00 525 - 600 V</b>							
6102 - 6172	1046	408	373 <sup>1)</sup>	1001	304	225	J
6222 - 6402	1327	408	373 <sup>1)</sup>	1282	304	225	J
6502 - 6652	1547	585	494 <sup>1)</sup>	1502	304	225	J
<b>IP 20/NEMA 1 525 - 600 V</b>							
6002 - 6011	395	220	200	384	200	100	C
6016 - 6027	560	242	260	540	200	200	D
6032 - 6042	700	242	260	680	200	200	D
6052 - 6072	800	308	296	780	270	200	D
6102 - 6172	1208	420	373 <sup>1)</sup>	1154	304	225	J
6222 - 6402	1588	420	373 <sup>1)</sup>	1535	304	225	J
6502 - 6652	2000	600	494 <sup>1)</sup>	-	-	225	H
<b>IP 54 525 - 600 V</b>							
6102 - 6172	1208	420	373 <sup>1)</sup>	1154	304	225	J
6222 - 6402	1588	420	373 <sup>1)</sup>	1535	304	225	J
6502 - 6652	2000	600	494 <sup>1)</sup>	-	-	225	H

aa: Minimum space above enclosure

bb: Minimum space below enclosure

1) With disconnect add 44 mm.

### ■ Mechanical dimensions

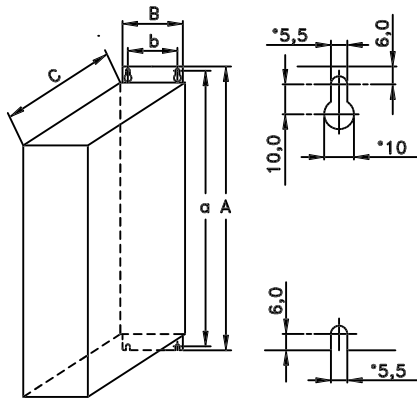

Type A, IP20

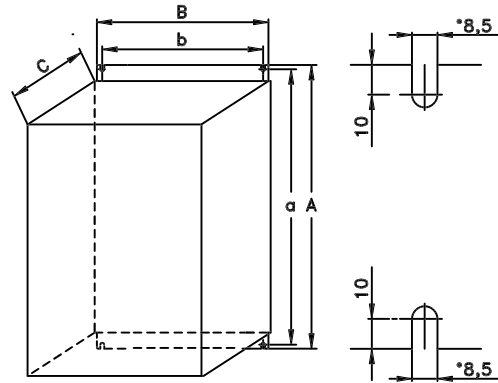

Type D, IP20

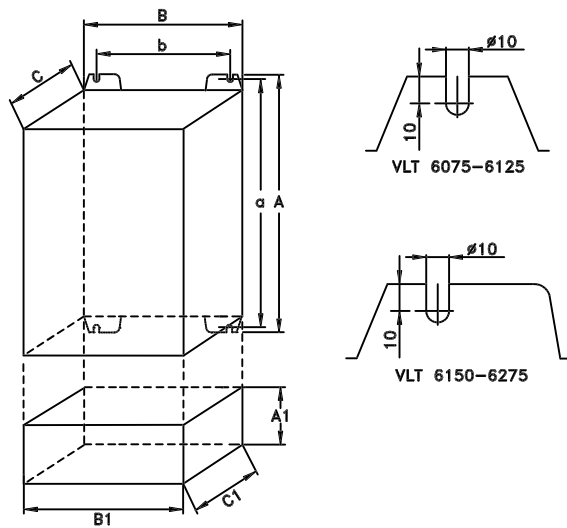

Type B, IP00  
With option and enclosure IP20

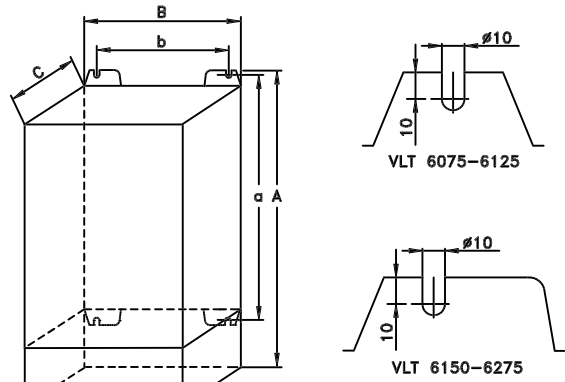

Type E, IP20

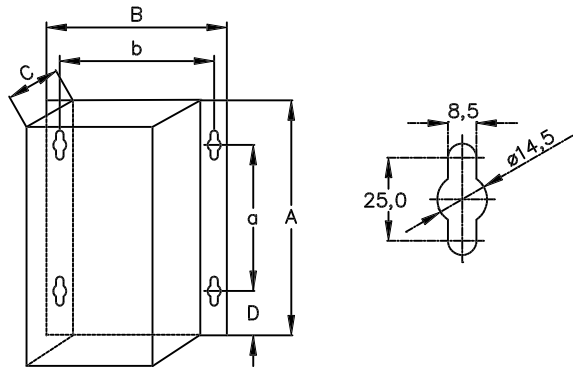

Type F, IP54

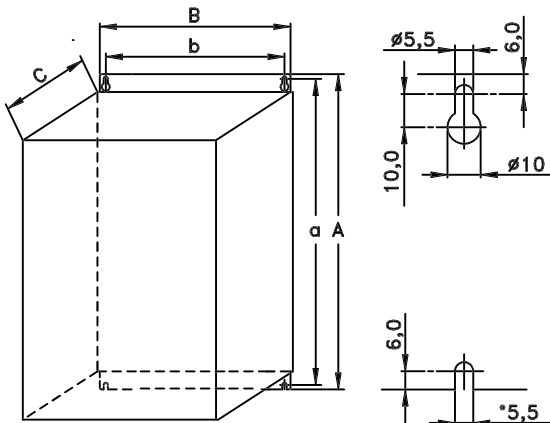

Type C, IP20

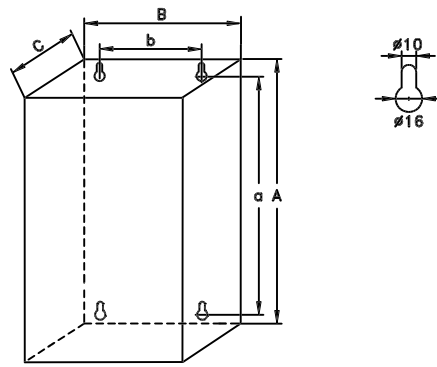

Type G, IP54

Installation

■ Mechanical dimensions (cont.)

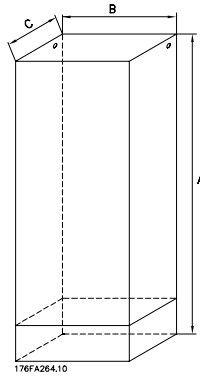

Type H, IP 20, IP 54

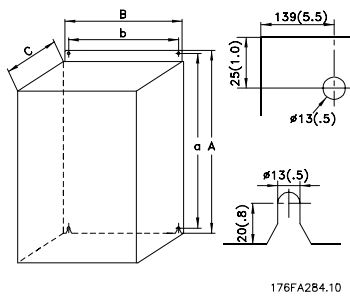

Type I, IP 00

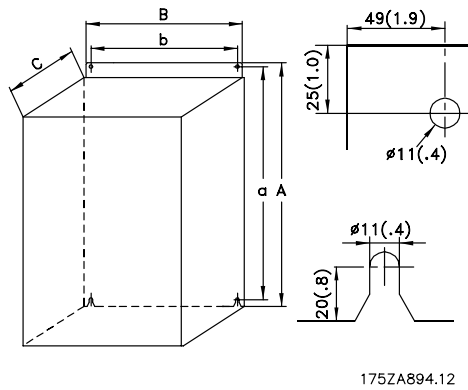

Type J, IP 00, IP 21, IP 54

### ■ Mechanical installation



Please pay attention to the requirements that apply to integration and field mounting kit, see the below list. The information given in the list must be observed to avoid serious damage or injury, especially when installing large units.

The frequency converter *must* be installed vertically.

The frequency converter is cooled by means of air circulation. For the unit to be able to release its cooling air, the *minimum* distance over and below the unit must be as shown in the illustration below.

To protect the unit from overheating, it must be ensured that the ambient temperature *does not rise above the max. temperature stated for the frequency converter* and that the 24-hour average temperature *is not exceeded*. The max. temperature and 24-hour average can be seen from the *General Technical Data*.

If the ambient temperature is in the range of 45°C -55° C, derating of the frequency converter will become relevant, see *Derating for ambient temperature*.

The service life of the frequency converter will be reduced if derating for ambient temperature is not taken into account.

### ■ Installation of VLT 6002-6652

All frequency converters must be installed in a way that ensures proper cooling.

#### Cooling

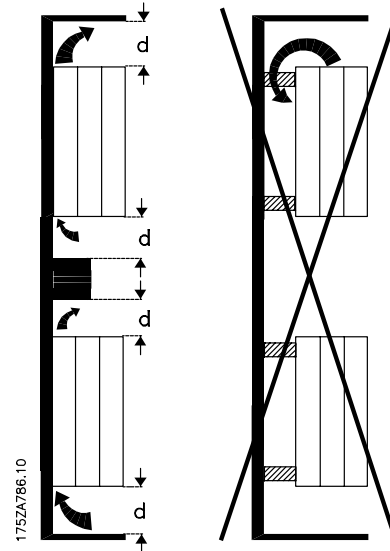

All Bookstyle and Compact units require a minimum space above and below the enclosure.

Installation

### Side by side/flange by flange

All frequency converters can be mounted side by side/flange by flange.

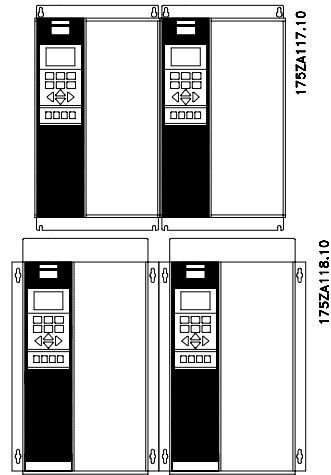
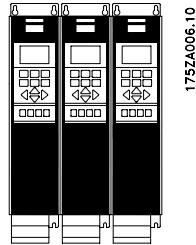

	d [mm]	Comments
<b>Bookstyle</b>		
VLT 6002-6005, 200-240 V	100	Installation on a plane, vertical surface (no spacers)
VLT 6002-6011, 380-460 V	100	
<b>Compact (all enclosure types)</b>		
VLT 6002-6005, 200-240 V	100	Installation on a plane, vertical surface (no spacers)
VLT 6002-6011, 380-460 V	100	
VLT 6002-6011, 525-600 V	100	
VLT 6006-6032, 200-240 V	200	Installation on a plane, vertical surface (no spacers)
VLT 6016-6072, 380-460 V	200	
VLT 6102-6122, 380-460 V	225	
VLT 6016-6072, 525-600 V	200	
VLT 6042-6062, 200-240 V	225	Installation on a plane, vertical surface (no spacers)
VLT 6102-6402, 525-600 V	225	
VLT 6152-6352, 380-460 V	225	
VLT 6402-6602, 380-460 V	225	IP 00 above and below enclosure.
VLT 6502-6652, 525-600 V		IP 21/IP 54 only above enclosure.

### ■ Installation of VLT 6402-6602 380-460 V and VLT 6502-6652, 525-600 V Compact IP 21 and IP 54

#### Cooling

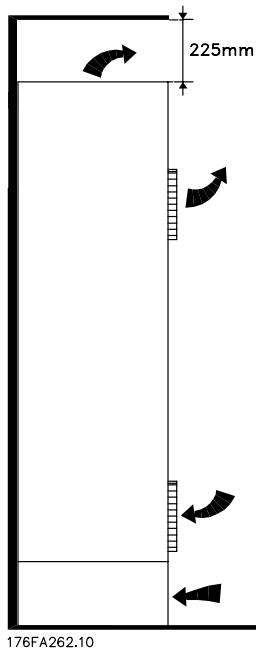

All units in the above-mentioned series require a minimum space of 225 mm above the enclosure and must be installed on a flat level surface. This applies to both IP 21 and IP 54 units.

Gaining access requires a minimum space of 579 mm in front of the frequency converter.

#### Side-by-side

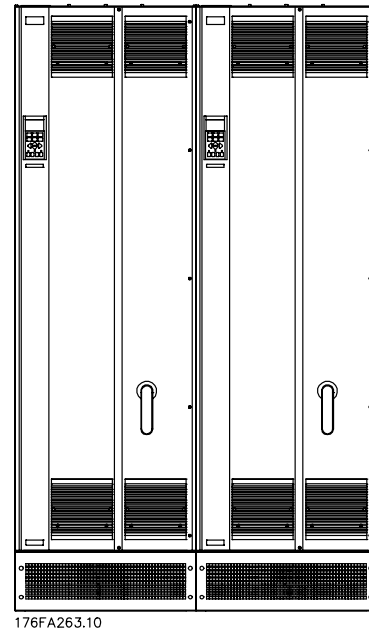

All IP 21 and IP 54 units in the above-mentioned series can be installed side by side without any space between them, since these units do not require cooling on the sides.

### ■ General information about electrical installation

#### ■ High voltage warning



The voltage of the frequency converter is dangerous whenever the equipment is connected to mains. Incorrect installation of the motor or the frequency converter may cause damage to the equipment, serious personal injury or death. Consequently, the instructions in this Design Guide, as well as national and local safety regulations, must be complied with. Touching the electrical parts may be fatal - even after disconnection from mains:

Using VLT 6002-6005, 200-240 V wait at least 4 minutes  
Using VLT 6006-6062, 200-240 V wait at least 15 minutes  
Using VLT 6002-6005, 380-460 V wait at least 4 minutes  
Using VLT 6006-6072, 380-460 V wait at least 15 minutes  
Using VLT 6102-6352, 380-460 V wait at least 20 minutes  
Using VLT 6402-6602, 380-460 V wait at least 40 minutes  
Using VLT 6002-6006, 525-600 V wait at least 4 minutes  
Using VLT 6008-6027, 525-600 V wait at least 15 minutes  
Using VLT 6032-6072, 525-600 V wait at least 30 minutes  
Using VLT 6102-6402, 525-600 V wait at least 20 minutes  
Using VLT 6502-6652, 525-600 V wait at least 30 minutes



#### **NB!:**

It is the user's or certified electrician's responsibility to ensure correct earthing and protection in accordance with applicable national and local norms and standards.

#### ■ Earthing

The following basic issues need to be considered when installing a frequency converter, so as to obtain electromagnetic compatibility (EMC).

- Safety earthing: Please note that the frequency converter has a high leakage current and must be earthed appropriately for safety reasons. Apply local safety regulations.
- High-frequency earthing: Keep the earth wire connections as short as possible.

Connect the different earth systems at the lowest possible conductor impedance. The lowest possible conductor impedance is obtained by keeping the

conductor as short as possible and by using the greatest possible surface area. A flat conductor, for example, has a lower HF impedance than a round conductor for the same conductor cross-section  $C_{V_{ESS}}$ . If more than one device is installed in cabinets, the cabinet rear plate, which must be made of metal, should be used as a common earth reference plate. The metal cabinets of the different devices are mounted on the cabinet rear plate using the lowest possible HF impedance. This avoids having different HF voltages for the individual devices and avoids the risk of radio interference currents running in connection cables that may be used between the devices. The radio interference will have been reduced. In order to obtain a low HF impedance, use the fastening bolts of the devices as HF connection to the rear plate. It is necessary to remove insulating paint or similar from the fastening points.

#### ■ Cables

Control cables and the filtered mains cable should be installed separate from the motor cables so as to avoid interference overcoupling. Normally, a distance of 20 cm will be sufficient, but it is recommended to keep the greatest possible distance wherever possible, especially where cables are installed in parallel over a substantial distance. With respect to sensitive signal cables, such as telephone cables and data cables, the greatest possible distance is recommended with a minimum of 1 m per 5 m of power cable (mains and motor cable). It must be pointed out that the necessary distance depends on the sensitivity of the installation and the signal cables, and that therefore no precise values can be stated. If cable jaws are used, sensitive signal cables are not to be placed in the same cable jaws as the motor cable or brake cable. If signal cables are to cross power cables, this should be done at an angle of 90 degrees. Remember that all interference-filled in- or outgoing cables to/from a cabinet should be screened/armoured or filtered.

See also *EMC-correct electrical installation*.

#### ■ Screened/armoured cables

The screen must be a low HF-impedance screen. This is ensured by using a braided screen of copper, aluminium or iron. Screen armour intended for mechanical protection, for example, is not suitable for an EMC-correct installation. See also *Use of EMC-correct cables*.



**■ Extra protection with regard to indirect contact**

ELCB relays, multiple protective earthing or earthing can be used as extra protection, provided that local safety regulations are complied with. In the case of an earth fault, a DC content may develop in the faulty current.

Never use ELCB relays, type A, since such relays are not suitable for DC fault currents.

If ELCB relays are used, this must be:

- Suitable for protecting equipment with a direct current content (DC) in the faulty current (3-phase bridge rectifier)
- Suitable for power-up with short charging current to earth
- Suitable for a high leakage current

### ■ RFI switch

#### Mains supply isolated from earth:

If the frequency converter is supplied from an isolated mains source ( IT mains) or TT/TN-S mains with grounded leg, the RFI switch is recommended to be turned off (OFF)<sup>1)</sup>. For further reference, see IEC 364-3. In case optimum EMC performance is needed, parallel motors are connected or the motor cable length is above 25 m, it is recommended to set the switch in ON position.

In OFF position, the internal RFI capacities (filter capacitors) between the chassis and the intermediate circuit are cut off to avoid damage to the intermediate circuit and to reduce the earth capacity currents (according to IEC 61800-3).

Please also refer to the application note *VLT on IT mains*, MN.90.CX.02. It is important to use isolation monitors that are capable for use together with power electronics (IEC 61557-8).



#### **NB!:**

The RFI switch is not to be operated with mains connected to the unit. Check that the mains supply has been disconnected before operating the RFI switch.



#### **NB!:**

Open RFI switch is only allowed at factory set switching frequencies.



#### **NB!:**

The RFI switch connects the capacitors galvanically to earth.

The red switches are operated by means of e.g. a screwdriver. They are set in the OFF position when they are pulled out and in ON position when they are pushed in. Factory setting is ON.

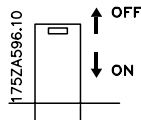

#### Mains supply connected to earth:

The RFI switch must be in ON position in order for the frequency converter to comply with the EMC standard.

1) Not possible with 6102-6652, 525-600 V units.

#### Position of RFI switches

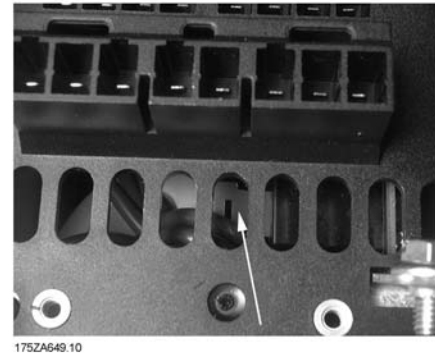

#### **Bookstyle IP 20**

**VLT 6002 - 6011 380 - 460 V**

**VLT 6002 - 6005 200 - 240 V**

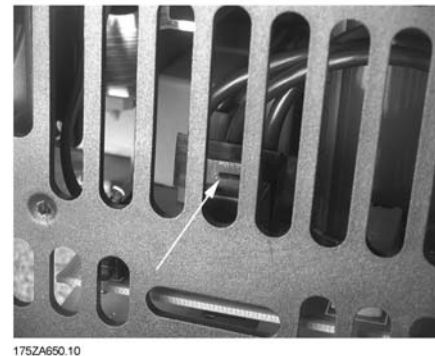

#### **Compact IP 20 and NEMA 1**

**VLT 6002 - 6011 380 - 460 V**

**VLT 6002 - 6005 200 - 240 V**

**VLT 6002 - 6011 525 - 600 V**

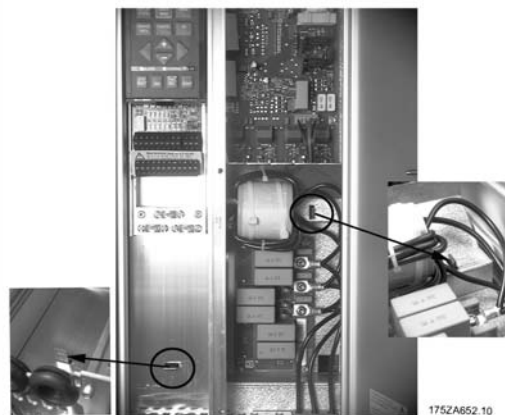

#### **Compact IP 20 and NEMA 1**

**VLT 6016 - 6027 380 - 460 V**

**VLT 6006 - 6011 200 - 240 V**

**VLT 6016 - 6027 525 - 600 V**

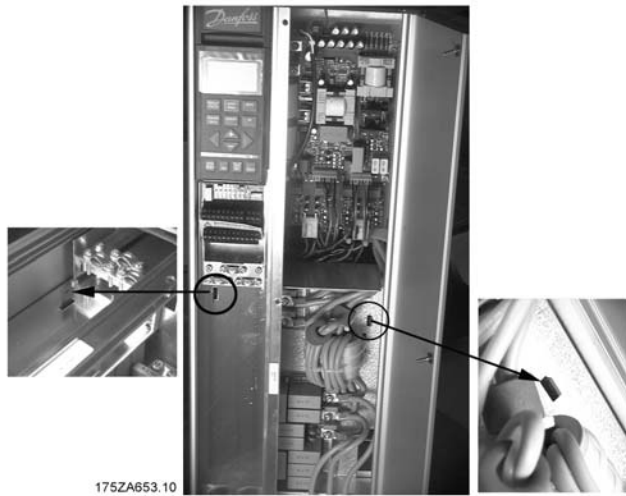

**Compact IP 20 and NEMA 1**  
**VLT 6032 - 6042 380 - 460 V**  
**VLT 6016 - 6022 200 - 240 V**  
**VLT 6032 - 6042 525 - 600 V**

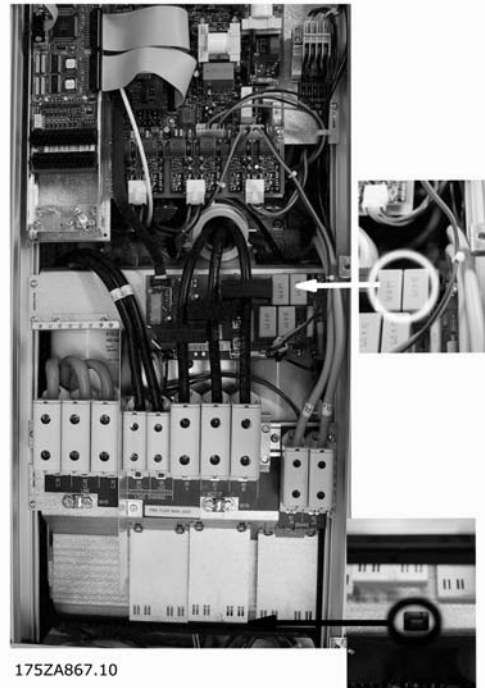

**Compact IP 54**  
**VLT 6102 - 6122 380 - 460 V**

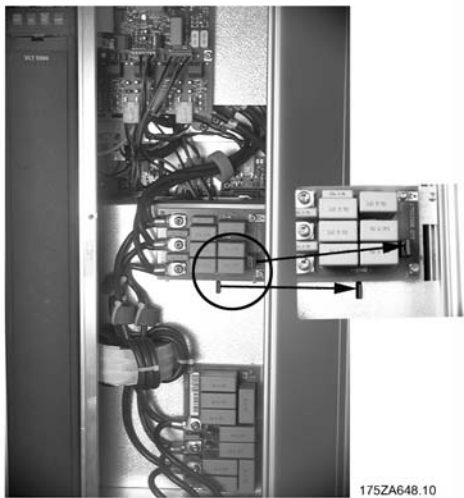

**Compact IP 20 and NEMA 1**  
**VLT 6052 - 6122 380 - 460 V**  
**VLT 6027 - 6032 200 - 240 V**  
**VLT 6052 - 6072 525 - 600 V**

Installation

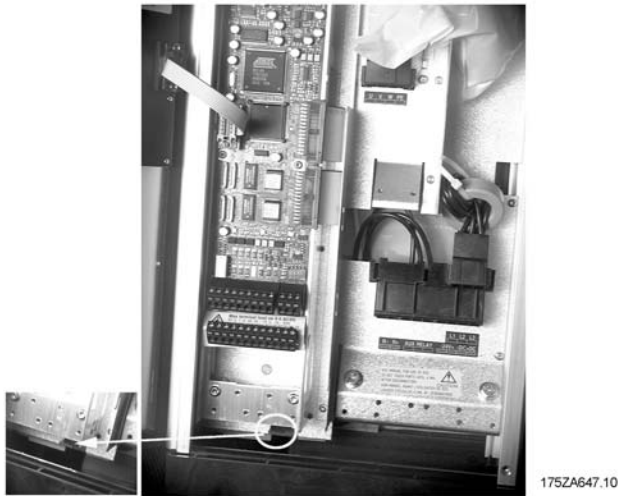

**Compact IP 54**  
**VLT 6002 - 6011 380 - 460 V**  
**VLT 6002 - 6005 200 - 240 V**

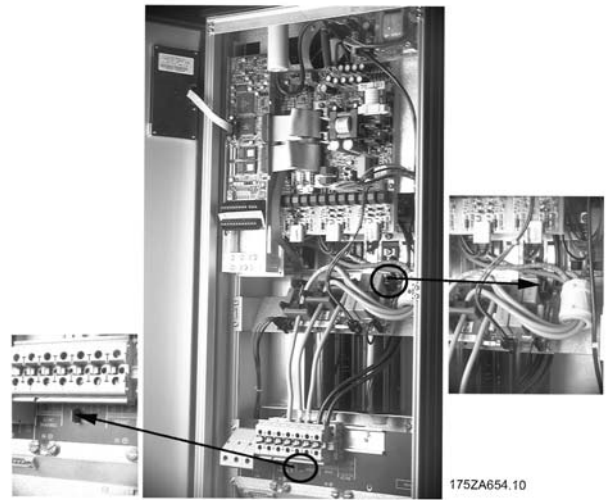

**Compact IP 54**  
**VLT 6042 - 6072 380 - 460 V**  
**VLT 6016 - 6032 200 - 240 V**



**Compact IP 54**  
**VLT 6016 - 6032 380 - 460 V**  
**VLT 6006 - 6011 200 - 240 V**

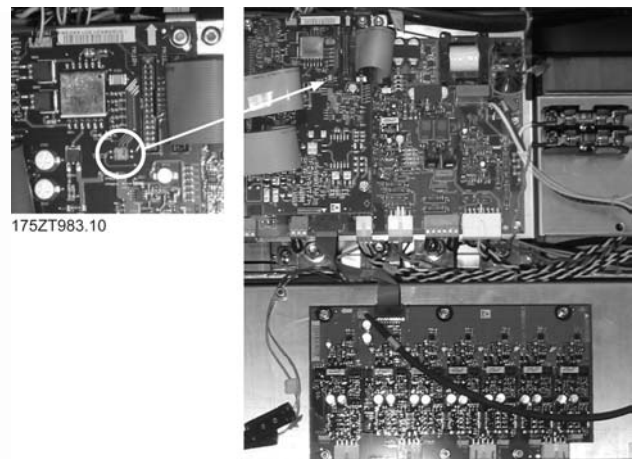

**All enclosure types**  
**VLT 6152 - 6602, 380 - 460 V**

**High voltage test**

A high voltage test can be carried out by short-circuiting terminals U, V, W, L1, L2 and L3 and energizing by max. 2.5 kV DC for one second between this short-circuit and the chassis.

**NB!:**

The RFI switch must be closed (position ON) when high voltage tests are carried out.

The mains and motor connection must be interrupted in the case of high voltage tests of the total installation if the leakage currents are too high.

**Heat emission from VLT 6000 HVAC**

The tables in *General technical data* show the power loss  $P_{\phi}$  (W) from VLT 6000 HVAC. The maximum cooling air temperature  $t_{IN\ MAX}$ , is 40° at 100% load (of rated value).

**Ventilation of integrated VLT 6000 HVAC**

The quantity of air required for cooling frequency converters can be calculated as follows:

1. Add up the values of  $P_{\phi}$  for all the frequency converters to be integrated in the same panel. The highest cooling air temperature ( $t_{IN}$ ) present must be lower than  $t_{IN\ MAX}$  (40°C). The day/night average must be 5°C lower (VDE 160). The outlet temperature of the cooling air must not exceed:  $t_{OUT\ MAX}$  (45° C).
2. Calculate the permissible difference between the temperature of the cooling air ( $t_{IN}$ ) and its outlet temperature ( $t_{OUT}$ ):  

$$\Delta t = 45^{\circ} C - t_{IN}$$
3. Calculate the required quantity of air =  $\frac{\sum P_{\phi} \times 3.1}{\Delta t}$  m<sup>3</sup>/h  
 insert  $\Delta t$  in Kelvin

The outlet from the ventilation must be placed above the highest-mounted frequency converter. Allowance must be made for the pressure loss across the filters and for the fact that the pressure is going to drop as the filters are choked.

**EMC correct electrical installation**

Following these guidelines is recommended in cases where compliance with EN 61000-6-3/4, EN 55011 or EN 61800-3 *First environment* is required. If the installation is in EN 61800-3 *Second environment*, then it is acceptable to deviate from these guidelines. It is however not recommended. See also *CE labelling*,

*Emission and EMC test results* under special conditions in the Design Guide for further details.

**Good engineering practice to ensure EMC correct electrical installation:**

- Use only braided screened/armoured motor cables and control cables. The screen should provide a minimum coverage of 80%. The screen material must be metal, not limited to but typically copper, aluminium, steel or lead. There are no special requirements for the mains cable.
- Installations using rigid metal conduits are not required to use screened cable, but the motor cable must be installed in conduit separate from the control and mains cables. Full connection of the conduit from the drive to the motor is required. The EMC performance of flexible conduits varies a lot and information from the manufacturer must be obtained.
- Connect the screen/armour/conduit to earth at both ends for motor cables and control cables. See also *Earthing of braided screened/armoured control cables*.
- Avoid terminating the screen/armour with twisted ends (pigtailed). Such a termination increases the high frequency impedance of the screen, which reduces its effectiveness at high frequencies. Use low impedance cable clamps or glands instead.
- Ensure good electrical contact between the mounting plate and the metal chassis of the frequency converter. This does not apply to IP54 units as they are designed for wall mounting and VLT 6152-6602, 380-480 V, VLT 6102-6652, 525-600 V, VLT 6042-6062, 200-240 VAC in IP20/NEMA1 enclosure.
- Use starwashers and galvanically conductive installation plates to secure good electrical connections for IP00, IP20, IP21 and NEMA 1 installations.
- Avoid using unscreened/unarmoured motor or control cables inside cabinets housing the drive(s), where possible.
- An uninterrupted high frequency connection between the frequency converter and the motor units is required for IP54 units.

The illustration shows an example of an EMC correct electrical installation of an IP20 or NEMA 1 frequency converter. The frequency converter has been fitted in an installation cabinet with an output contactor and connected to a PLC, which in this example is installed in a separate cabinet. Other ways of

making the installation may have as good an EMC performance, provided the above guide-lines to engineering practice are followed. Please note that when unscreened cables and control wires are used,

some emission requirements are not complied with, although the immunity requirements are fulfilled. See the section *EMC test results* for further details.

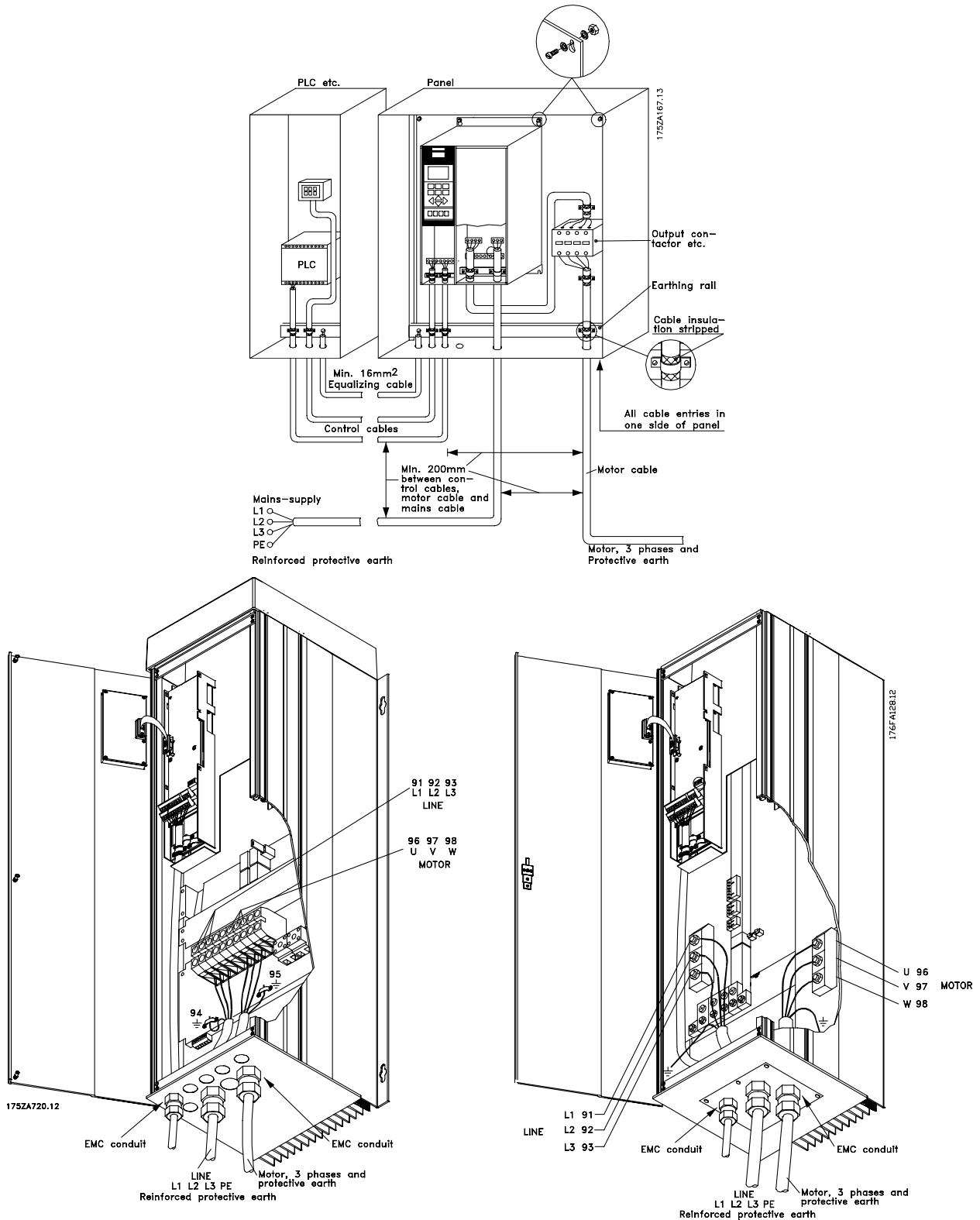

### ■ Use of EMC-correct cables

Braided screened/armoured cables are recommended to optimise EMC immunity of the control cables and the EMC emission from the motor cables.

The ability of a cable to reduce the in- and outgoing radiation of electric noise depends on the switching impedance ( $Z_T$ ). The screen of a cable is normally designed to reduce the transfer of electric noise; however, a screen with a lower  $Z_T$  value is more effective than a screen with a higher  $Z_T$ .

$Z_T$  is rarely stated by cable manufacturers, but it is often possible to estimate  $Z_T$  by assessing the physical design.

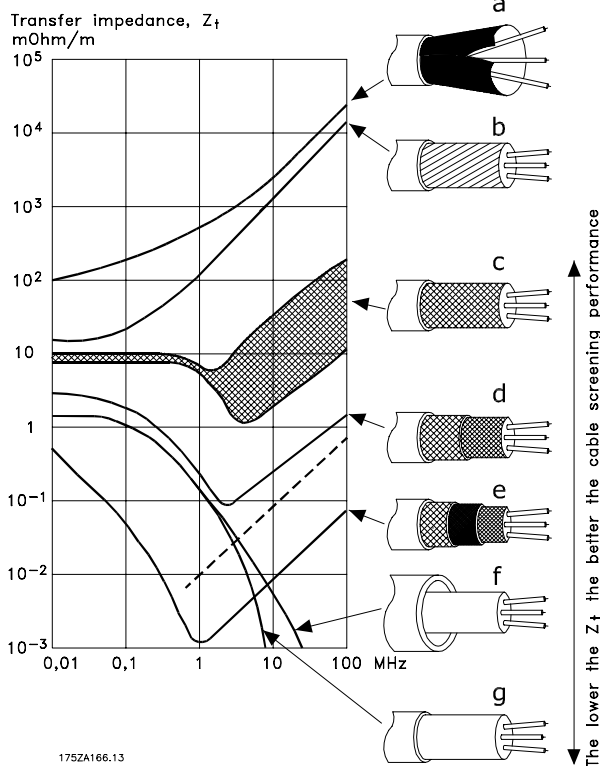

$Z_T$  can be assessed on the basis of the following factors:

- The contact resistance between the individual screen conductors.
- The screen coverage, i.e. the physical area of the cable covered by the screen - often stated as a percentage value. Should be min. 85%.
- Screen type, i.e. braided or twisted pattern.

Aluminium-clad with copper wire.

Twisted copper wire or armoured steel wire cable.

Single-layer braided copper wire with varying percentage screen coverage.

Double-layer braided copper wire.

Twin layer of braided copper wire with a magnetic, screened/armoured intermediate layer.

Cable that runs in copper tube or steel tube.

Lead cable with 1.1 mm wall thickness with full coverage.

■ **Electrical installation - earthing of control cables**

Generally speaking, control cables must be braided screened/armoured and the screen must be connected by means of a cable clamp at both ends to the metal cabinet of the unit.

The drawing below indicates how correct earthing is carried out and what to be done if in doubt.

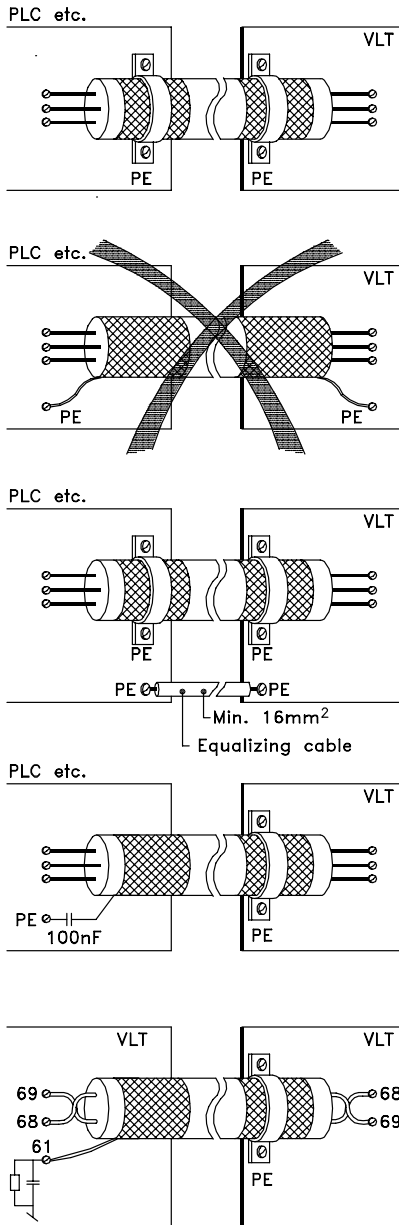

175ZA165.11

**Correct earthing**

Control cables and cables for serial communication must be fitted with cable clamps at both ends to ensure the best possible electrical contact

**Wrong earthing**

Do not use twisted cable ends (pigtailed), since these increase the screen impedance at high frequencies.

**Protection with respect to earth potential between PLC and VLT**

If the earth potential between the frequency converter and the PLC (etc.) is different, electric noise may occur that will disturb the whole system. This problem can be solved by fitting an equalising cable, to be placed next to the control cable. Minimum cable cross-section: 16 mm<sup>2</sup>.

**For 50/60 Hz earth loops**

If very long control cables are used, 50/60 Hz earth loops may occur. This problem can be solved by connecting one end of the screen to earth via a 100nF capacitor (keeping leads short).

**Cables for serial communication**

Low-frequency noise currents between two frequency converters can be eliminated by connecting one end of the screen to terminal 61. This terminal is connected to earth via an internal RC link. It is recommended to use twisted-pair cables to reduce the differential mode interference between the conductors.



### ■ Electrical installation, enclosures

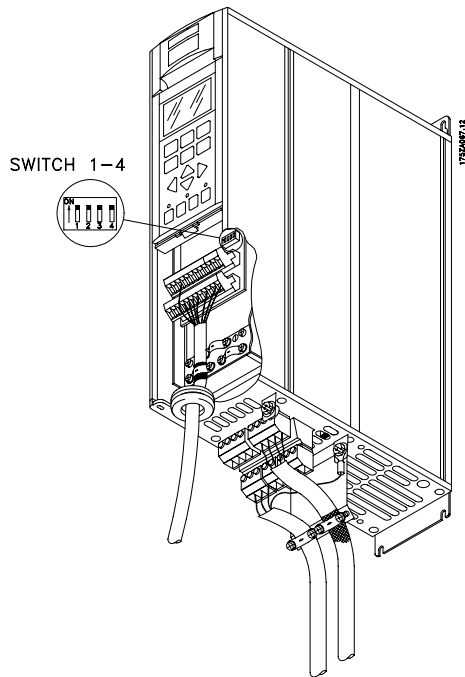

**Bookstyle IP 20**  
**VLT 6002-6005, 200-240 V**  
**VLT 6002-6011, 380-460 V**

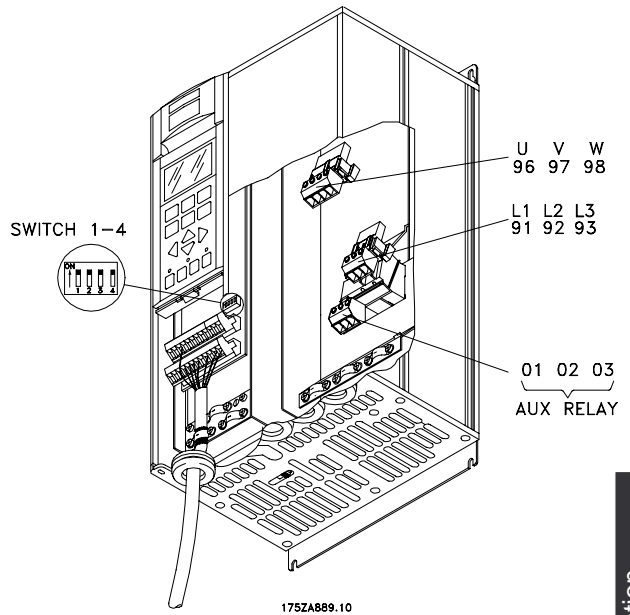

**Compact IP 20 and NEMA 1 (IP 20)**  
**VLT 6002-6005, 200-240 V**  
**VLT 6002-6011, 380-460 V**  
**VLT 6002-6011, 525-600 V**

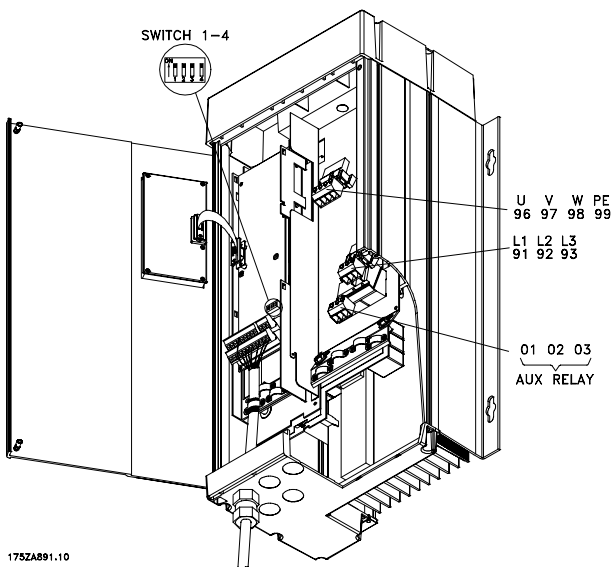

**Compact IP 54**  
**VLT 6002-6005, 200-240 V**  
**VLT 6002-6011, 380-460 V**

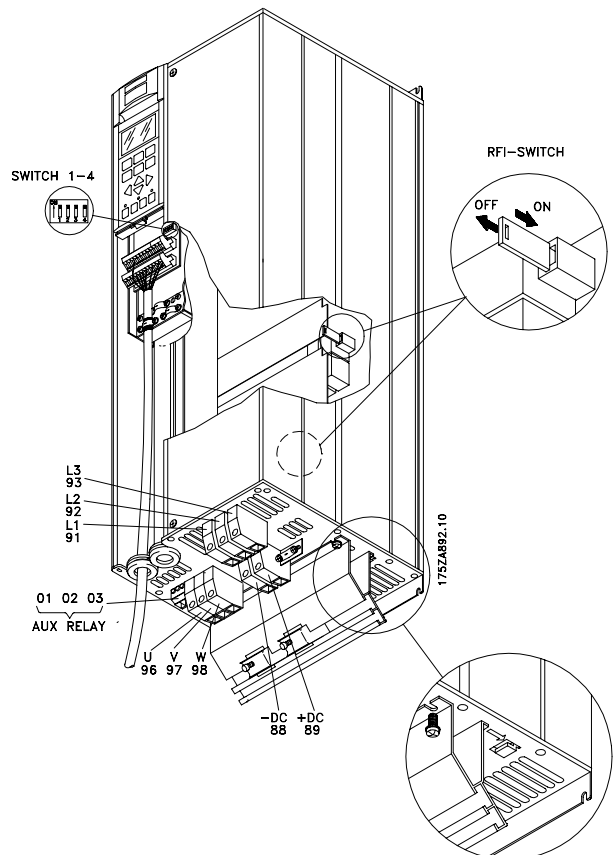

**Compact IP 20 and NEMA 1**  
**VLT 6006-6032, 200-240 V**  
**VLT 6016-6072, 380-460 V**  
**VLT 6016-6072, 525-600 V**

Installation

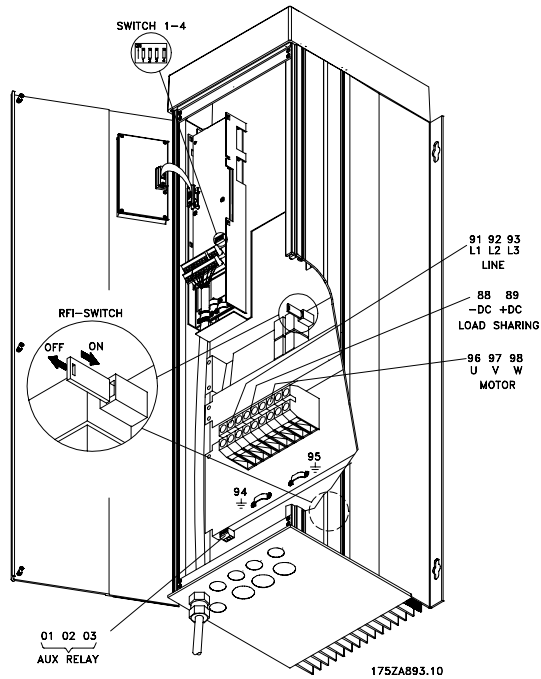

**Compact IP 00**  
VLT 6042-6062, 200-240 V

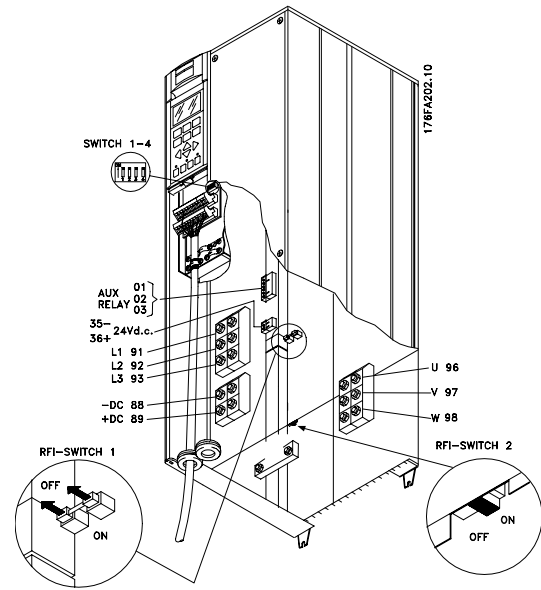

**Compact IP 54**  
VLT 6006-6032, 200-240 V  
VLT 6016-6072, 380-460 V

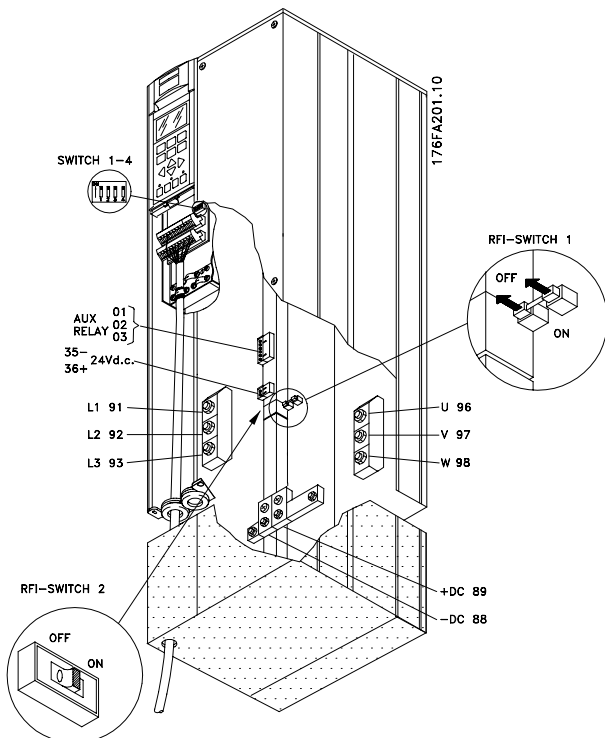

**Compact NEMA 1 (IP 20)**  
VLT 6042-6062, 200-240 V

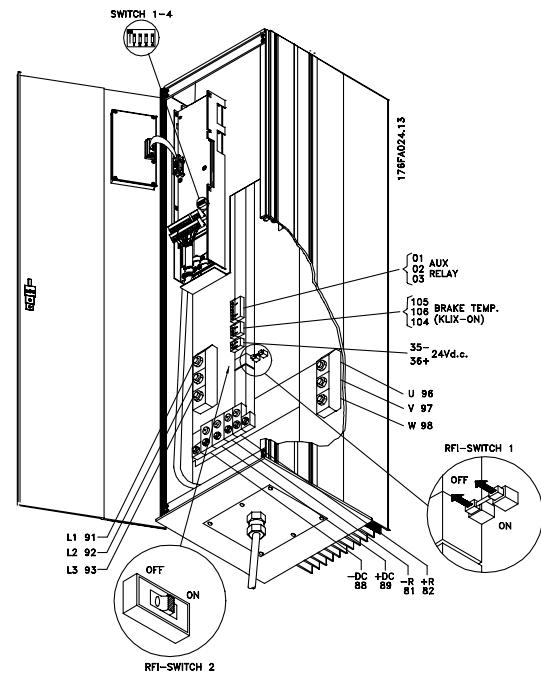

**Compact IP 54**  
VLT 6042-6062, 200-240 V

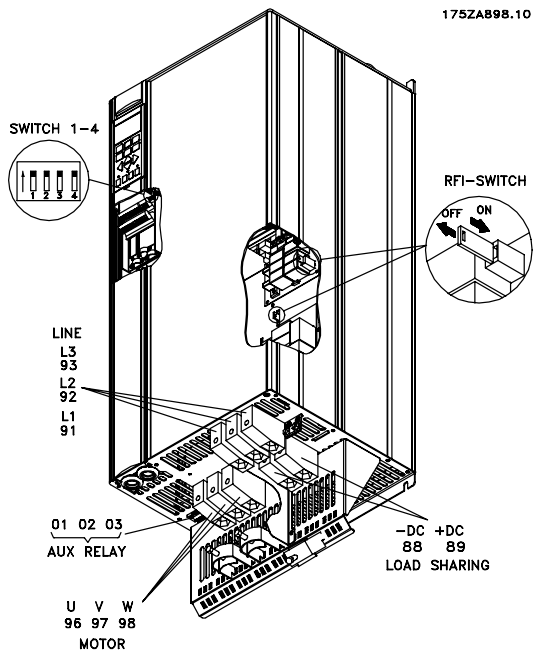

**Compact IP 20**  
VLT 6102-6122, 380-460 V

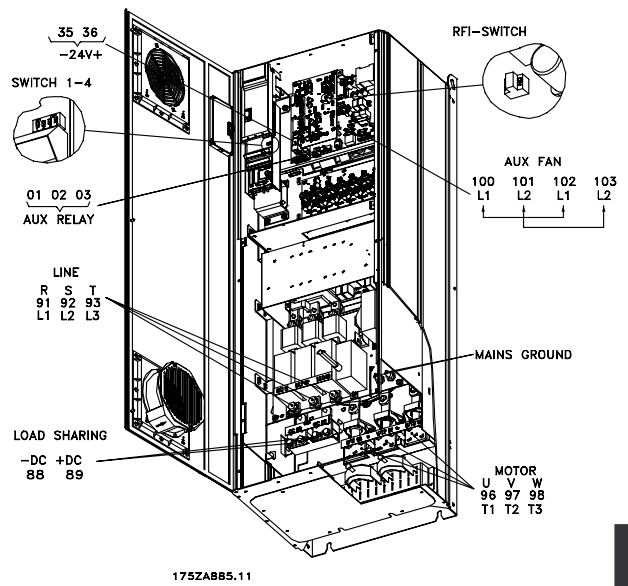

**IP 54, IP 21/NEMA 1**  
VLT 6152-6172, 380-460 V  
VLT 6102-6172, 525-600 V

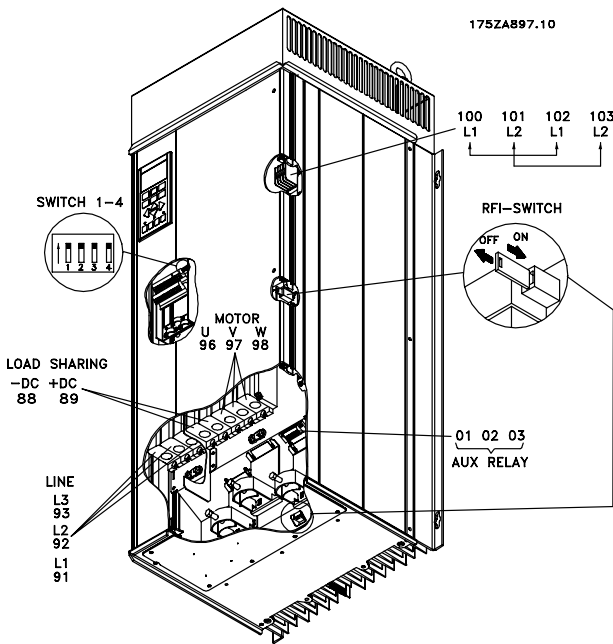

**Compact IP 54**  
VLT 6102-6122, 380-460 V

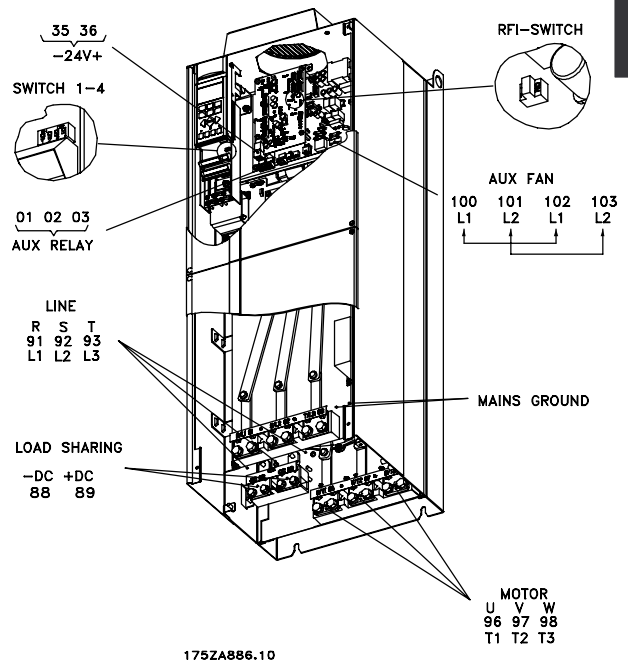

**IP 00**  
VLT 6152-6172, 380-460 V  
VLT 6102-6172, 525-600 V

Note: The RFI switch has no function in the 525-600 V drives.

Installation

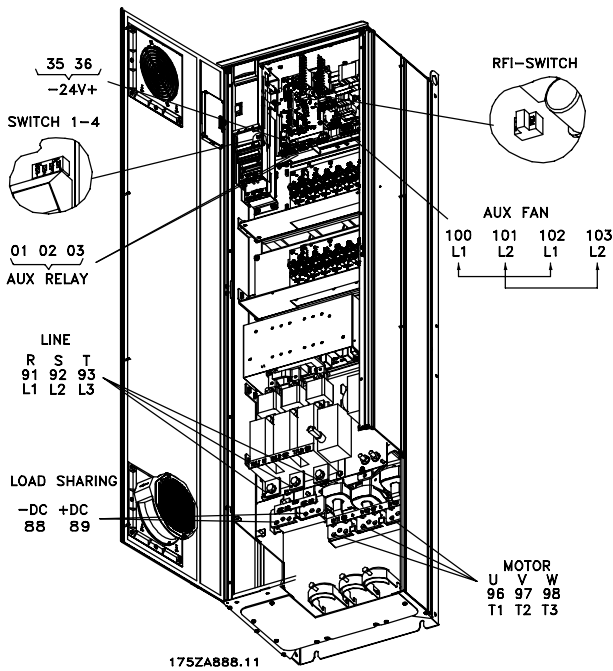

**IP 54, IP 21/NEMA 1 with disconnect and main fuse**  
**VLT 6222-6352, 380-460 V**  
**VLT 6222-6402, 525-600 V**

■ Electrical installation, power cables

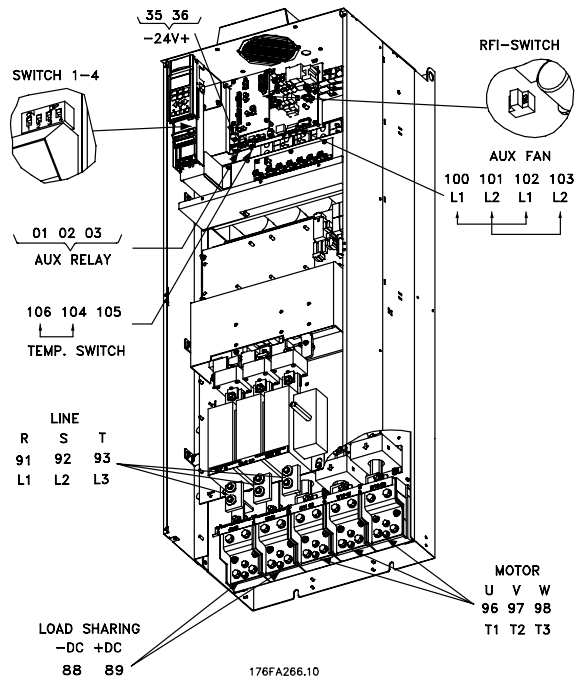

**Compact IP 00 with disconnect and fuse**  
**VLT 6402-6602 380-460 V and VLT**  
**6502-6652 525-600 V**

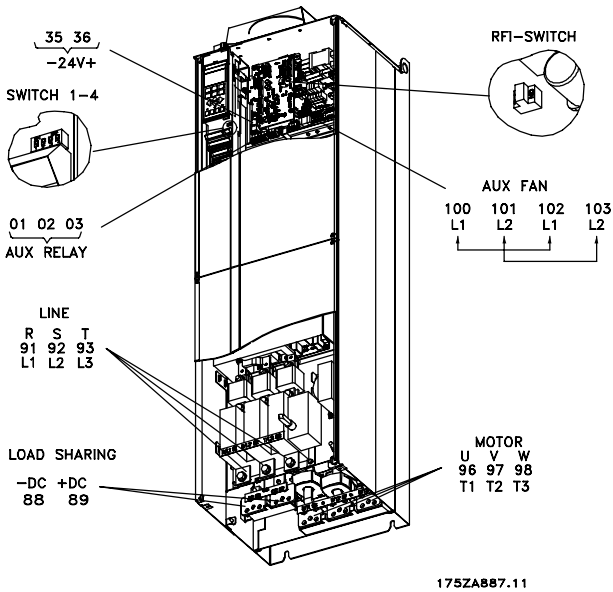

**IP 00 with disconnect and fuse**  
**VLT 6222-6352, 380-460 V**  
**VLT 6222-6402, 525-600 V**

Note: The RFI switch has no function in the 525-600 V drives.

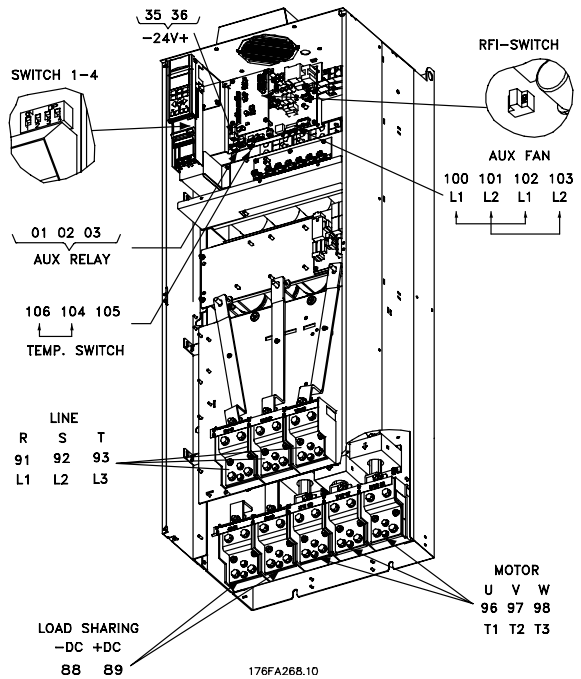

**Compact IP 00 without disconnect and fuse**  
**VLT 6402-6602 380-460 V and VLT**  
**6502-6652 525-600 V**

Note: The RFI switch has no function in the 525-600 V drives.

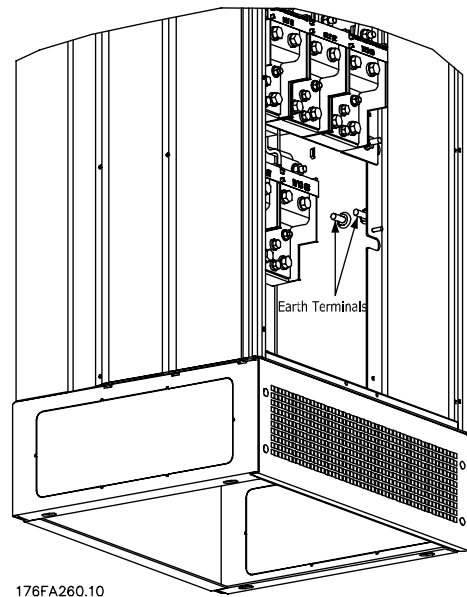
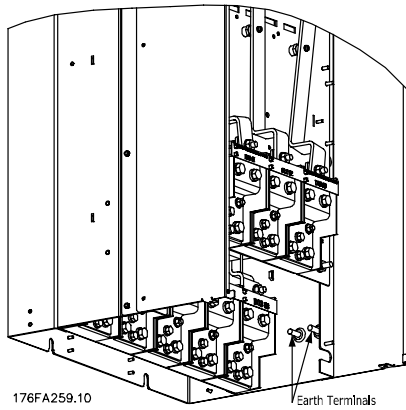

**Position of earth terminals, IP 00**

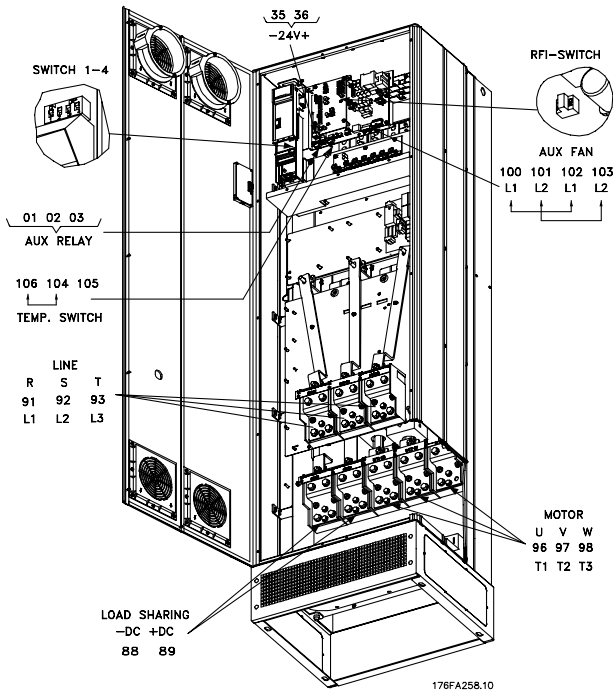

**Position of earth terminals, IP 21 / IP 54**

Installation

**Compact IP 21 / IP 54 without disconnect and fuse  
VLT 6402-6602 380-460 V and VLT  
6502-6652 525-600 V**

Note: The RFI switch has no function in the 525-600 V drives.

### ■ Electrical installation, power cables

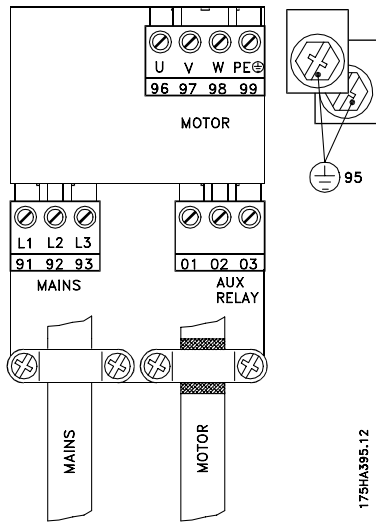

**Bookstyle IP 20**  
**VLT 6002-6005, 200-240 V**  
**VLT 6002-6011, 380-460 V**

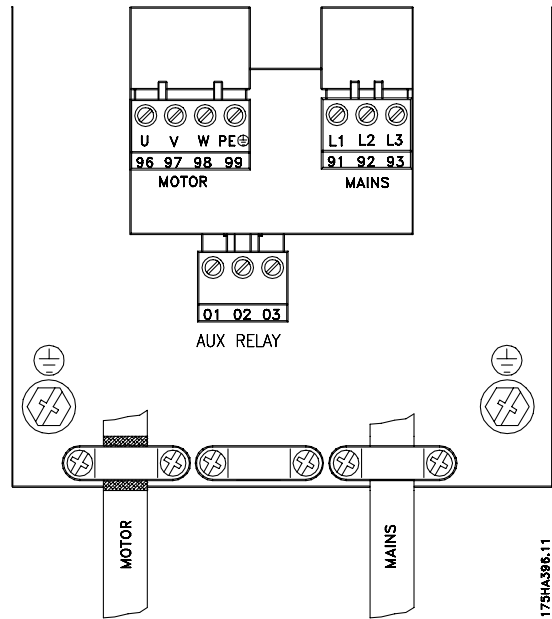

**Compact IP 20, NEMA 1, and IP 54**  
**VLT 6002-6005, 200-240 V**  
**VLT 6002-6011, 380-460 V**  
**VLT 6002-6011, 525-600 V**

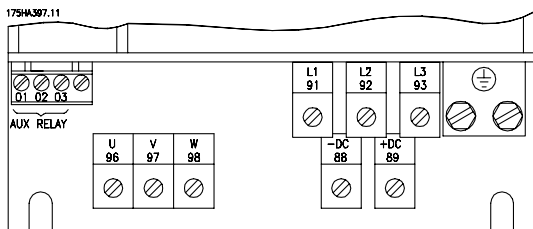

**IP 20 and NEMA 1**  
**VLT 6006-6032, 200-240 V**  
**VLT 6016-6122, 380-460 V**  
**VLT 6016-6072, 525-600 V**

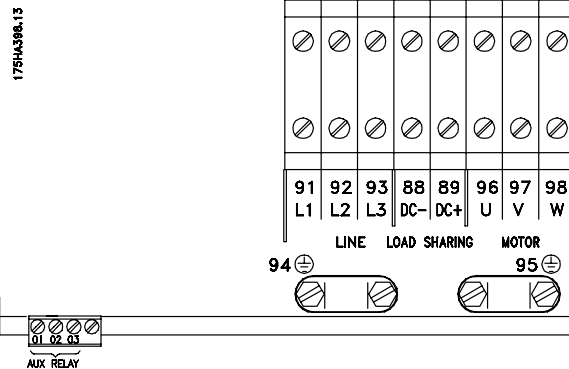

**IP 54**  
**VLT 6006-6032, 200-240 V**  
**VLT 6016-6072, 380-460 V**

■ Electrical installation, power cables

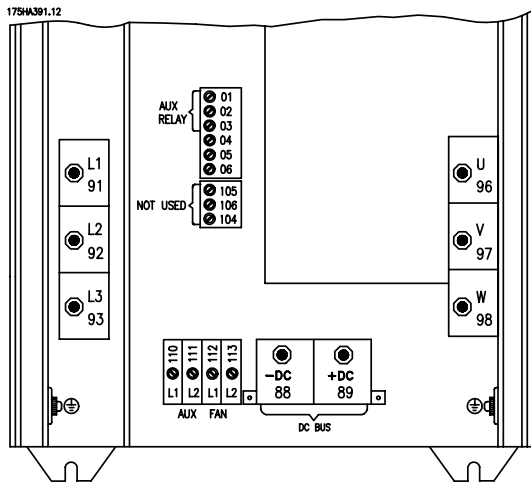

IP 00 and NEMA 1 (IP 20)  
VLT 6042-6062, 200-240 V

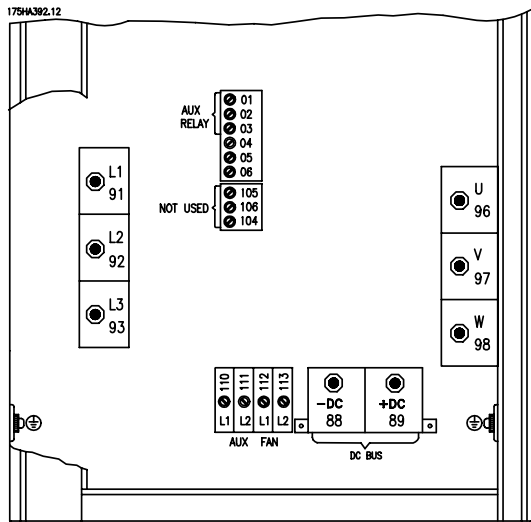

IP 54  
VLT 6042-6062, 200-240 V

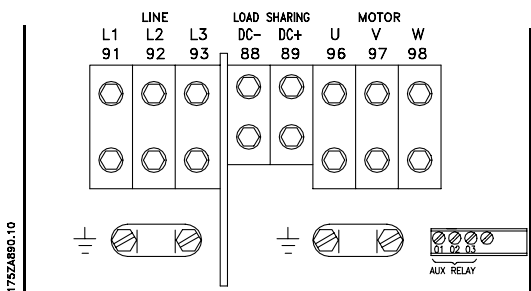

Compact IP 54  
VLT 6102-6122, 380-460 V

Installation

### ■ Tightening-up torque and screw sizes

The table shows the torque required when fitting terminals to the frequency converter. For VLT 6002-6032, 200-240 V, VLT 6002-6122, 380-460 and VLT 6002-6072 525-600 V the cables must be fastened with screws. For VLT 6042-6062, 200-240 V and for VLT 6152-6550, 380-460 V and VLT 6102-6652, 525-600 V the cables must be fastened with bolts. These figures apply to the following terminals:

Mains terminals (Nos.)	91, 92, 93 L1, L2, L3
Motor terminals (Nos.)	96, 97, 98 U, V, W
Earth terminal (Nos.)	94, 95, 99

VLT type	Tightening-up torque	Screw/bolt size	Tool
3 x 200 - 240 V			
VLT 6002-6005	0.5-0.6 Nm	M3	
VLT 6006-6011	1.8 Nm (IP 20)	M4	
VLT 6006-6016	1.8 Nm (IP 54)	M4	
VLT 6016-6027	3.0 Nm (IP 20)	M5 <sup>3)</sup>	4 mm
VLT 6022-6027	3.0 Nm (IP 54) <sup>2)</sup>	M5 <sup>3)</sup>	4 mm
VLT 6032	6.0 Nm	M6 <sup>3)</sup>	5 mm
VLT 6042-6062	11.3 Nm	M8 (bolt)	

VLT type	Tightening-up torque	Screw/bolt size	Tool
3 x 380-460 V			
VLT 6002-6011	0.5-0.6 Nm	M3	
VLT 6016-6027	1.8 Nm (IP 20)	M4	
VLT 6016-6032	1.8 Nm (IP 54)	M4	
VLT 6032-6052	3.0 Nm (IP 20)	M5 <sup>3)</sup>	4 mm
VLT 6042-6052	3.0 Nm (IP 54) <sup>2)</sup>	M5 <sup>3)</sup>	4 mm
VLT 6062-6072	6.0 Nm	M6 <sup>3)</sup>	5 mm
VLT 6102-6122	15 Nm (IP 20)	M8 <sup>3)</sup>	6 mm
	24 Nm (IP 54) <sup>1)</sup>	<sup>3)</sup>	8 mm
VLT 6152-6352	19 Nm <sup>4)</sup>	M10 (bolt) <sup>5)</sup>	16 mm
VLT 6402-6602	19 Nm	M10	16 mm

VLT type	Tightening-up torque	Screw/bolt size	Tool
3 x 525-600 V			
VLT 6002-6011	0.5-0.6 Nm	M3	
VLT 6016-6027	1.8 Nm	M4	
VLT 6032-6042	3.0 Nm <sup>2)</sup>	M5 <sup>3)</sup>	4 mm
VLT 6052-6072	6.0 Nm	M6 <sup>3)</sup>	5 mm
VLT 6102-6402	19 Nm <sup>4)</sup>	M10 (bolt) <sup>5)</sup>	16 mm
VLT 6502-6652	19 Nm	M10	16 mm
		(compression lug) <sup>5)</sup>	
	9.5 Nm	M8 (box lug) <sup>5)</sup>	13 mm

1. Loadsharing terminals 14 Nm/M6, 5 mm Allen key
2. IP 54 units with RFI filter line terminals 6 Nm
3. Allen screws (hexagon)

4. Loadsharing terminals 9.5 Nm/M8 (bolt)
5. Wrench

### ■ Mains connection

Mains must be connected to terminals 91, 92, 93.

	Mains voltage 3 x 200-240 V
91, 92, 93	Mains voltage 3 x 380-460 V
L1, L2, L3	Mains voltage 3 x 525-600 V



#### NB!

Check that the mains voltage fits the mains voltage of the frequency converter, which can be seen from the nameplate.

See *Technical data* for correct sizing of cable cross-sections.

### ■ Motor connection

The motor must be connected to terminals 96, 97, 98. Earth to terminal 94/95/99.

Nos.	
96, 97, 98	Motor voltage 0-100 % of mains voltage
U, V, W	
No. 94/95/99	Earth connection

See *Technical data* for correct sizing of cable cross-sections.

All types of three-phase asynchronous standard motors can be used with a VLT 6000 HVAC unit.

Small-size motors are normally star-connected. (220/380 V,  $\Delta/Y$ ). Large-size motors are delta-connected (380/660 V,  $\Delta/Y$ ). The correct connection and voltage can be read from the motor nameplate.



#### NB!

In older motors without phase coil insulation, a LC filter should be fitted to the frequency converter output. See the Design Guide or contact Danfoss.

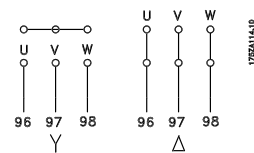



### Direction of motor rotation

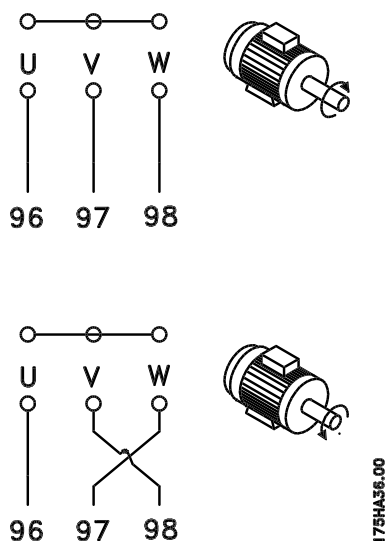

The factory setting is for clockwise rotation with the frequency transformer output connected as follows.

- Terminal 96 connected to U-phase
- Terminal 97 connected to V-phase
- Terminal 98 connected to W-phase

The direction of motor rotation can be changed by switching two phases in the motor cable.

### Parallel coupling of motors

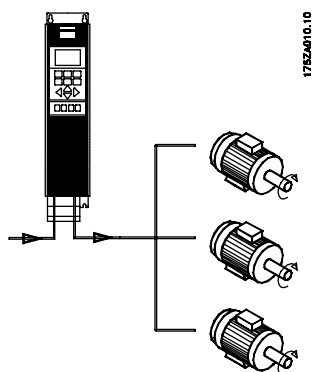

VLT 6000 HVAC is able to control several motors connected in parallel. If the motors are to have different rpm values, the motors must have different rated rpm values. Motor rpm is changed simultaneously, which means that the ratio between the rated rpm values is maintained across the range. The total current consumption of the motors is not to exceed the maximum rated output current  $I_{VLT,N}$  for the frequency converter.

Problems may arise at the start and at low rpm values if the motor sizes are widely different. This is because the relatively high ohmic resistance in small motors calls for a higher voltage at the start and at low rpm values. In systems with motors connected in parallel, the electronic thermal relay (ETR) of the frequency converter cannot be used as motor protection for the individual motor. Consequently, additional motor protection is required, such as thermistors in each motor (or individual thermal relays).

**NB!**  
 Parameter 107 *Automatic Motor Adaptation*, AMA and *Automatic Energy Optimization*, AEO in parameter 101 *Torque characteristics* cannot be used if motors are connected in parallel.

### Motor cables

See *Technical data* for correct sizing of motor cable cross-section and length. Always comply with national and local regulations on cable cross-sections.

**NB!**  
 If an unscreened cable is used, some EMC requirements are not complied with, see *EMC test results*.

If the EMC specifications regarding emission are to be complied with, the motor cable must be screened, unless otherwise stated for the RFI filter in question. It is important to keep the motor cable as short as possible so as to reduce the noise level and leakage currents to a minimum. The motor cable screen must be connected to the metal cabinet of the frequency converter and to the metal cabinet of the motor. The screen connections are to be made with the biggest possible surface (cable clamp). This is enabled by different installation devices in the different frequency converters. Mounting with twisted screen ends (pigtailed) is to be avoided, since these spoil the screening effect at higher frequencies. If it is necessary to break the screen to install a motor isolator or motor contactor, the screen must be continued at the lowest possible HF impedance.

Installation

### ■ Motor thermal protection

The electronic thermal relay in UL-approved frequency converters has received UL-approval for single motor protection, as long as parameter 117 *Motor thermal protection* has been set to ETR Trip and parameter 105 *Motor current*  $I_{VLT,N}$ , has been programmed for the rated motor current (can be read from the motor nameplate).

### ■ Earth connection

Since the leakage currents to earth may be higher than 3.5 mA, the frequency converter must always be earthed in accordance with applicable national and local regulations. In order to ensure good mechanical connection of the earth cable, its cable cross-section must be at least 10 mm<sup>2</sup>. For added security, an RCD (Residual Current Device) may be installed. This ensures that the frequency converter will cut out if the leakage currents get too high. See RCD instructions MI.66.AX.02.

### ■ Installation of 24 Volt external DC supply

Torque: 0.5 - 0.6 Nm

Screw size:

M3

No.	Function
35(-), 36 (+)	24 V External DC supply (Available with VLT 6152-6602 380-460 V and VLT 6102-6652, 525-600 V only)

24 V external DC supply can be used as low-voltage supply to the control card and any option cards installed. This enables full operation of the LCP (incl. parameter setting) without connection to mains. Please note that a warning of low voltage will be given when 24 V DC has been connected; however, there will be no tripping. If 24 V external DC supply is connected or switched on at the same time as the mains supply, a time of min. 200 msec. must be set in parameter 111, *Start delay*. A pre-fuse of min. 6 Amp, slow-blow, can be fitted to protect the external 24 V DC supply. The power consumption is 15-50 W, depending on the load on the control card.



#### NB!:

Use 24 V DC supply of type PELV to ensure correct galvanic isolation (type PELV) on the control terminals of the frequency converter.

### ■ DC bus connection

The DC bus terminal is used for DC back-up, with the intermediate circuit being supplied from an external DC source.

Terminal nos.

88, 89

Contact Danfoss if you require further information.

### ■ High-voltage relay

The cable for the high-voltage relay must be connected to terminals 01, 02, 03. The high-voltage relay is programmed in parameter 323, *Relay 1, out-put*.

No. 1

Relay output 1  
1+3 break, 1+2 make  
Max 240 V AC, 2 Amp  
Min. 24 V DC 10 mA or  
24 V AC, 100 mA

Max Cross-section:

4 mm<sup>2</sup>/10 AWG

Torque:

0.5-0.6 Nm

Screw size:

M3

### ■ Control card

All terminals for the control cables are located under the protective cover of the frequency converter. The protective cover (see drawing below) can be removed by means of a pointed object - a screwdriver or similar.

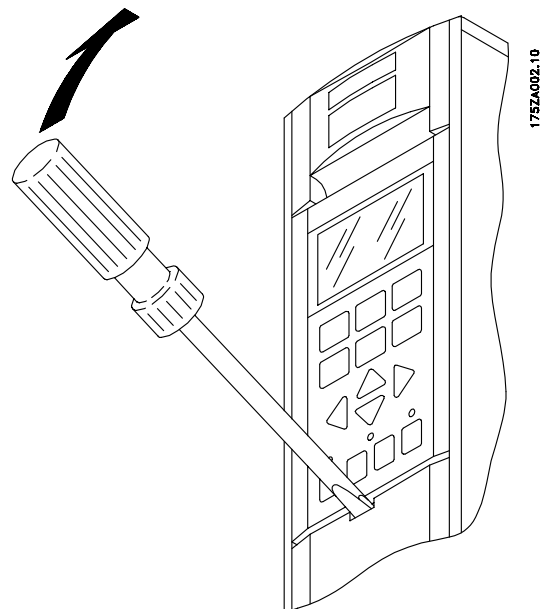

### ■ Electrical installation, control cables

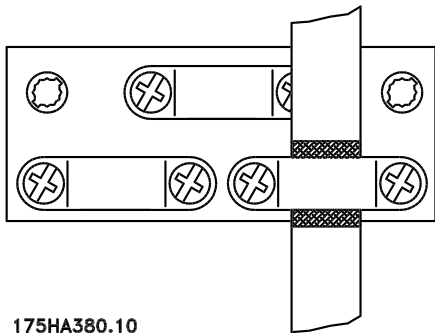

175HA380.10

Torque: 0.5-0.6 Nm  
Screw size: M3

Generally speaking, control cables must be screened/armoured and the screen must be connected by means of a cable clamp at both ends to the metal cabinet of the unit (see *Earthing of screened/armoured control cables*). Normally, the screen must also be connected to the body of the controlling unit (follow the instructions for installation given for the unit in question). If very long control cables are used, 50/60 Hz earth loops may occur that will disturb the whole system. This problem can be solved by connecting one end of the screen to earth via a 100nF condenser (keeping leads short).

### ■ Electrical installation, control cables

Max. control cable cross section: 1.5 mm<sup>2</sup> /16 AWG  
Torque: 0.5-0.6 Nm  
Screw size: M3  
See *Earthing of screened/armoured control cables* for correct termination of control cables.

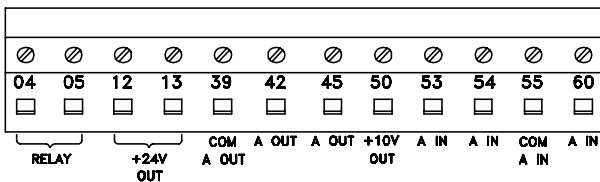
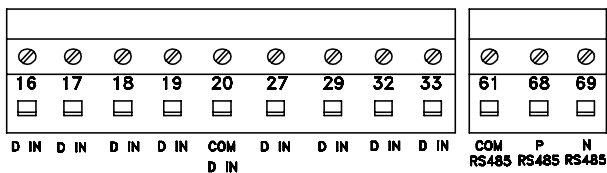

175HA379.10

No.	Function
04, 05	Relay output 2 can be used for indicating status and warnings.
12, 13	Voltage supply to digital inputs. For the 24 V DC to be used for digital inputs, switch 4 on the control card must be closed, position "on".
16-33	Digital inputs. See parameters 300-307 <i>Digital inputs</i> .
20	Ground for digital inputs.
39	Ground for analogue/digital outputs. Must be connected to terminal 55 by means of a three-wire transmitter. See <i>Examples of connection</i> .
42, 45	Analogue/digital outputs for indicating frequency, reference, current and torque. See parameters 319-322 <i>Analogue/digital outputs</i> .
50	Supply voltage to potentiometer and thermistor 10 V DC.
53, 54	Analogue voltage input, 0 - 10 V DC.
55	Ground for analogue voltage inputs.
60	Analogue current input 0/4-20 mA. See parameters 314-316 <i>Terminal 60</i> .
61	Termination of serial communication. See <i>Earthing of screened/armoured control cables</i> . This terminal is not normally to be used.
68, 69	RS 485 interface, serial communication. Where the frequency converter is connected to a bus, switches 2 and 3 (switches 1 - 4 - see next page) must be closed on the first and the last frequency converter. On the remaining frequency converters, switches 2 and 3 must be open. The factory setting is closed (position on).

Installation

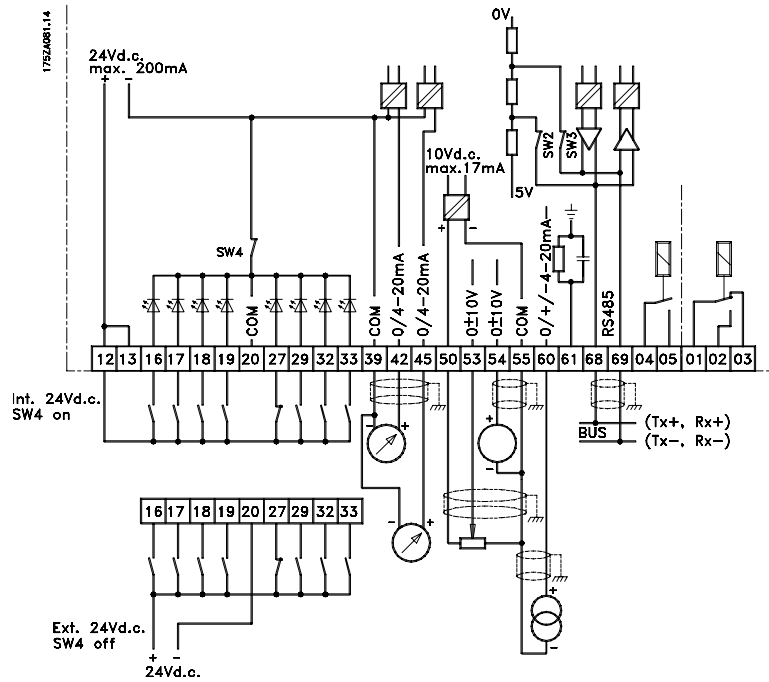

### Switches 1-4

The dipswitch is located on the control card. It is used for serial communication and external DC supply. The switching position shown is the factory setting.

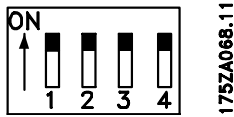

Switch 1 has no function.

Switches 2 and 3 are used for terminating an RS-485 interface to the serial communication bus

**NB!** When the frequency converter is the first or last device on the serial communication bus, switches 2 and 3 must be ON in that designated VLT. Any other VLTs on the serial communication bus must have switches 2 and 3 set to OFF.

**NB!** Please note that when Switch 4 is in position "OFF," the external 24 V DC supply is galvanically isolated from the frequency converter.

### Bus connection

The serial bus connection in accordance with the RS 485 (2-conductor) norm is connected to terminals 68/69 of the frequency converter (signals P and N). Signal P is the positive potential (TX+,RX+), while signal N is the negative potential (TX-,RX-).

If more than one frequency converter is to be connected to a given master, use parallel connections.

175ZA079.11

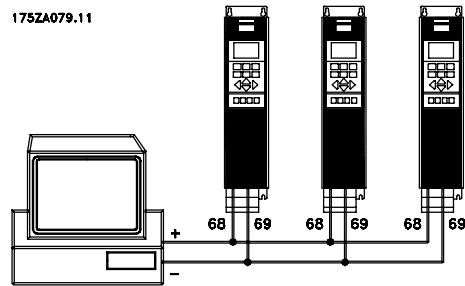

In order to avoid potential equalizing currents in the screen, the cable screen can be earthed via terminal 61, which is connected to the frame via an RC-link.

### ■ Connection examples, VLT 6000 HVAC

The diagram below gives an example of a typical VLT 6000 HVAC installation.

The mains supply is connected to terminals 91 (L1), 92 (L2) and 93 (L3), while the motor is connected to 96 (U), 97 (V) and 98 (W). These numbers can also be seen from the terminals of the frequency converter.

An external DC supply or a 12-pulse option can be connected to terminals 88 and 89. Please ask Danfoss for a Design Guide to learn more.

Analogue inputs can be connected to terminals 53 [V], 54 [V] and 60 [mA]. These inputs can be programmed for either reference, feedback or thermistor. See *Analogue inputs* in parameter group 300.

There are 8 digital inputs, which can be connected to terminals 16-19, 27, 29, 32, 33. These inputs can be programmed in accordance with the table in *Inputs and outputs 300-328*.

There are two analogue/digital outputs (terminals 42 and 45), which can be programmed to show the present status or a process value, such as  $0-f_{MAX}$ . Relay outputs 1 and 2 can be used for giving the present status or a warning.

On terminals 68 (P+) and 69 (N-) RS 485 interface, the frequency converter can be controlled and monitored via serial communication.

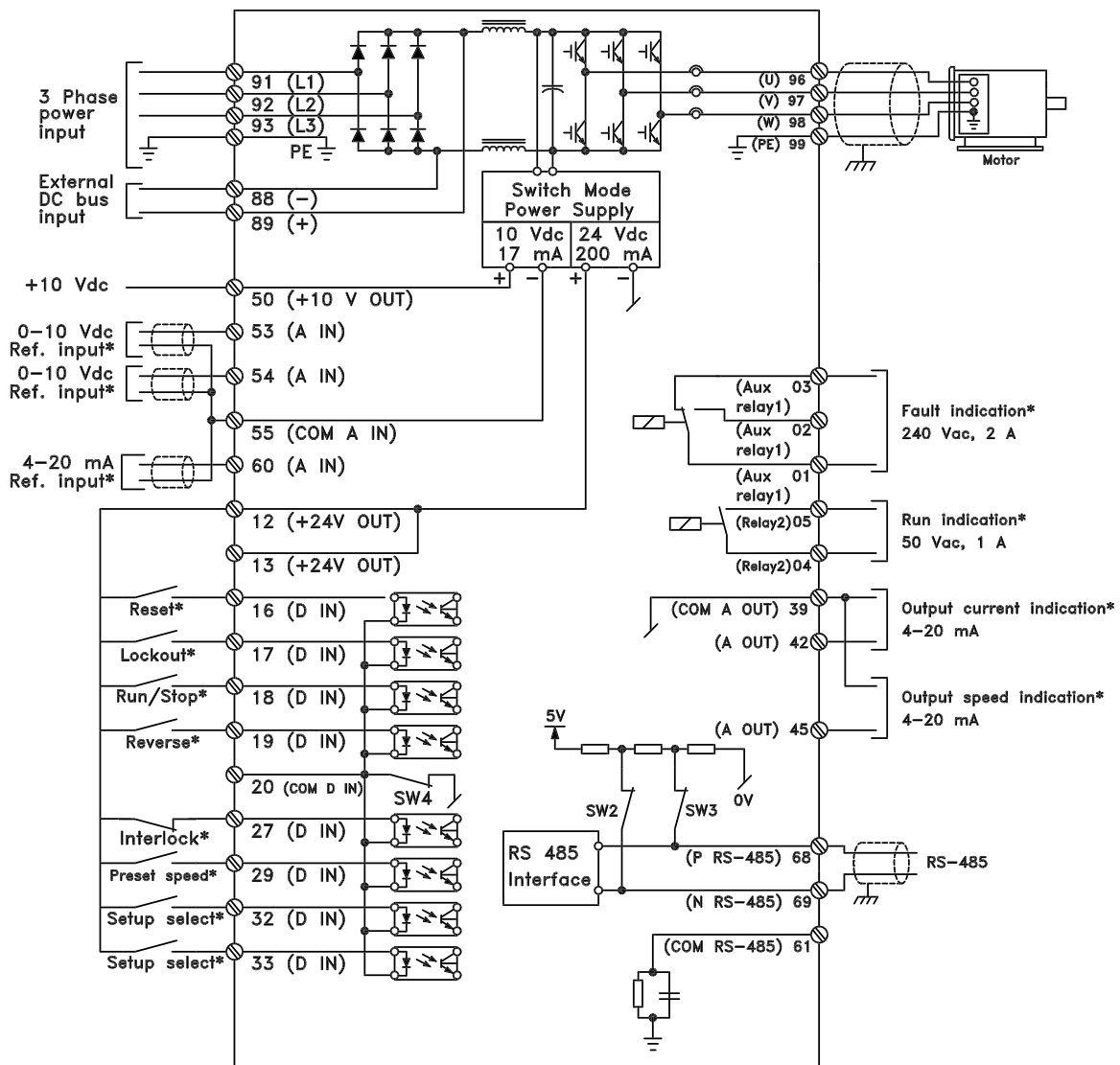

175HA390.12

Installation

### ■ Single-pole start/stop

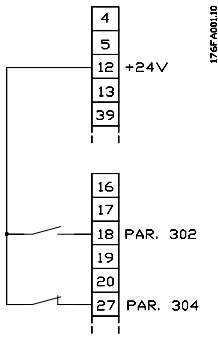

- Start/stop using terminal 18.  
Parameter 302 = *Start* [1]
- Quick-stop using terminal 27.  
Parameter 304 = *Coasting stop, inverse* [0]

- Start permitted with terminal 16.  
Parameter 300 = *Run permissive* [8]
- Start/stop with terminal 18.  
Parameter 302 = *Start* [1]
- Quickstop with terminal 27.  
Parameter 304 = *Coasting stop, inverse* [0].
- Activated damper (motor)  
Parameter 323 = *Start command active* [13].

### ■ 2-zone regulation

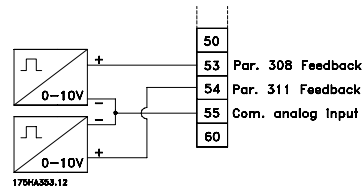

- Parameter 308 = *Feedback* [2].
- Parameter 311 = *Feedback* [2].

### ■ Digital speed up/down

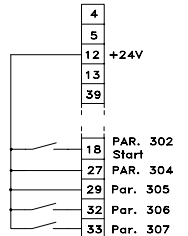

- Speed up and down using terminals 32 and 33.  
Parameter 306 = *Speed up* [7]  
Parameter 307 = *Speed down* [7]  
Parameter 305 = *Freeze reference* [2]

### ■ Transmitter connection

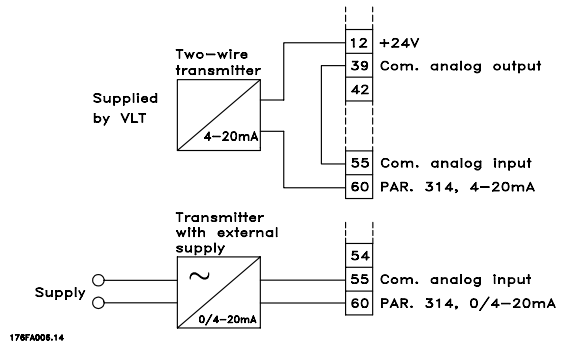

- Parameter 314 = *Reference* [1]
- Parameter 315 = *Terminal 60, min. scaling*
- Parameter 316 = *Terminal 60, max. scaling*

### ■ Potentiometer reference

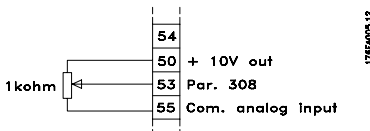

- Parameter 308 = *Reference* [1]  
Parameter 309 = *Terminal 53, min. scaling*  
Parameter 310 = *Terminal 53, max. scaling*

### ■ Run permissive

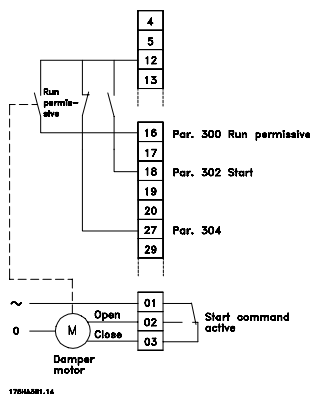

■ Control unit LCP

The front of the frequency converter features a control panel - LCP(Local Control Panel). This is a complete interface for operation and programming of the frequency converter.

The control panel is detachable and can - as an alternative - be installed up to 3 metres away from the frequency converter, e.g. on the front panel, by means of a mounting kit option.

The functions of the control panel can be divided into five groups:

1. Display
2. Keys for changing display mode
3. Keys for changing program parameters
4. Indicator lamps
5. Keys for local operation

All data are indicated by means of a 4-line alphanumeric display, which, in normal operation, is able to show 4 operating data values and 3 operating condition values continuously. During programming, all the information required for quick, effective parameter Setup of the frequency converter will be displayed.

As a supplement to the display, there are three indicator lamps for voltage (ON), warning (WARNING) and alarm (ALARM), respectively.

All frequency converter parameter Setups can be changed immediately via the control panel, unless this function has been programmed to be *Locked* [1] via parameter 016 *Lock for data change* or via a digital input, parameters 300-307 *Data change lock*.

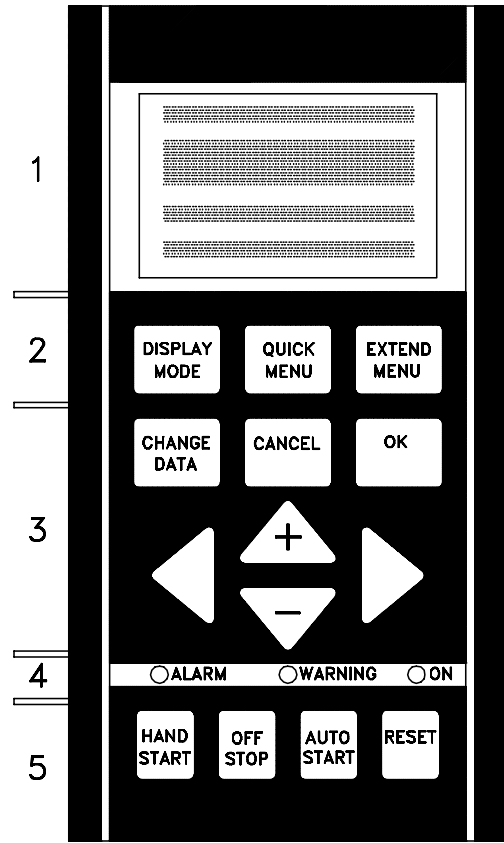

Programming

■ Control keys for parameter setup

The control keys are divided into functions. This means that the keys between display and indicator lamps are used for parameter Setup, including selecting the display indication during normal operation.

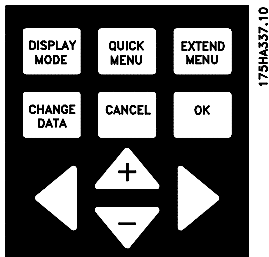

DISPLAY MODE

[DISPLAY MODE] is used for selecting the indication mode of the display or when returning to the Display mode from either the Quick menu or the Extend menu mode.



[QUICK MENU] gives access to the parameters used for the Quick menu. It is possible to switch between the Quick menu and the Extend menu modes.



[EXTEND MENU] gives access to all parameters. It is possible to switch between the Extend menu and the Quick menu modes.



[CHANGE DATA] is used for changing a setting selected either in the Extend menu or the Quick menu mode.



[CANCEL] is used if a change of the selected parameter is not to be carried out.



[OK] is used for confirming a change of the parameter selected.



[+/-] is used for selecting parameters and for changing a chosen parameter. These keys are also used to change the local reference.



In addition, the keys are used in Display mode to switch between operation variable readouts.

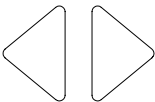

[<>] is used when selecting a parameter group and for moving the cursor when changing numerical values.

### Indicator lamps

At the bottom of the control panel is a red alarm lamp and a yellow warning lamp, as well as a green voltage LED.



If certain threshold values are exceeded, the alarm and/ or warning lamp is activated, and a status or alarm text is displayed.



#### NB!:

The voltage indicator lamp is activated when the frequency converter receives voltage.

### Local control

Underneath the indicator lamps are keys for local control.

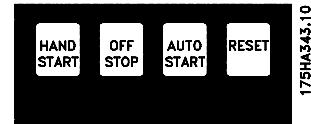

[HAND START] is used if the frequency converter is to be controlled via the control unit. The frequency converter will start the motor, since a start command is given by means of [HAND START].

On the control terminals, the following control signals will still be active when [HAND START] is activated:

- Hand start - Off stop - Auto start
- Safety Interlock
- Reset
- Coasting stop inverse
- Reversing
- Setup select lsb - Setup select msb
- Jog
- Run permissive
- Lock for data change
- Stop command from serial communication



#### NB!:

If parameter 201 *Output frequency low limit*  $f_{MIN}$  is set to an output frequency greater than 0 Hz, the motor will start and ramp up to this frequency when [HAND START] is activated.



[OFF/STOP] is used for stopping the connected motor. Can be selected as Enable [1] or Disable [0] via parameter 013. If the stop function is activated, line 2 will flash.



[AUTO START] is used if the frequency converter is to be controlled via the control terminals and/or serial communication. When a start signal is active on the control terminals and/or the bus, the frequency converter will start.



#### NB!:

An active HAND-OFF-AUTO signal via the digital inputs will have higher priority than the control keys [HAND START]-[AUTO START].





[RESET] is used for resetting the frequency converter after an alarm (trip). Can be selected as *Enable* [1] or *Disable* [0] via parameter 015 *Reset on LCP*.

See also *List of warnings and alarms*.

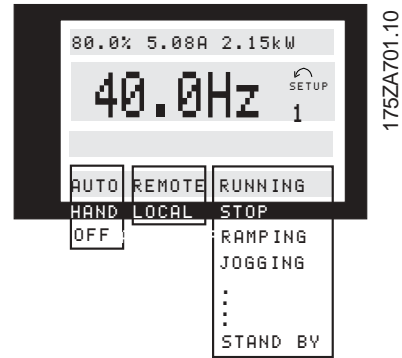

### ■ Display mode

In normal operation, any 4 different operating variables can be indicated continuously: 1.1 and 1.2 and 1.3 and 2. The present operating status or alarms and warnings that have arisen are shown in line 2 in the form of a number. In the case of alarms, the alarm in question will be shown in lines 3 and 4, accompanied by an explanatory note. Warnings will flash in line 2, with an explanatory note in line 1. In addition, the display shows the active Setup. The arrow indicates the direction of rotation; here the frequency converter has an active reversing signal. The arrow body disappears if a stop command is given or if the output frequency falls below 0.01 Hz. The bottom line gives the status of the frequency converter. The scroll list on the next page gives the operating data that can be shown for variable 2 in display mode. Changes are made via the [+/-] keys.

1st line  
2nd line  
3rd line  
4th line



### ■ Display mode, cont.

Three operating data values can be shown in the first display line, while one operating variable can be shown in the second display line. To be programmed via parameters 007, 008, 009 and 010 *Display read-out*.

- Status line (4th line):

The left part of the status line indicates the control element of the frequency converter that is active. AUTO means that control is via the control terminals, while HAND indicates that control is via the local keys on the control unit. OFF means that the frequency converter ignores all control commands and stops the motor. The centre part of the status line indicates the reference element that is active. REMOTE means that the reference from the control terminals is active, while LOCAL indicates that the reference is determined via the [+/-] keys on the control panel. The last part of the status line indicates the current status, for example "Running", "Stop" or "Alarm".

### ■ Display mode I:

VLT 6000 HVAC offers different display modes depending on the mode selected for the frequency converter. The figure on the next page shows the way to navigate between different display modes. Below is a display mode, in which the frequency converter is in Auto mode with remote reference at an output frequency of 40 Hz. In this display mode, reference and control are determined via the control terminals. The text in line 1 gives the operating variable shown in line 2.

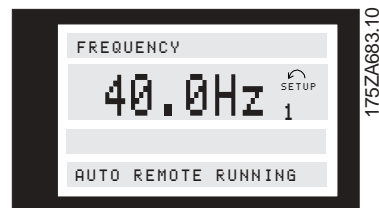

Line 2 gives the current output frequency and the active Setup.

Line 4 says that the frequency converter is in Auto mode with remote reference, and that the motor is running.

■ **Display mode II:**

This display mode makes it possible to have three operating data values displayed at the same time in line 1. The operating data values are determined in parameters 007-010 *Display readout*.

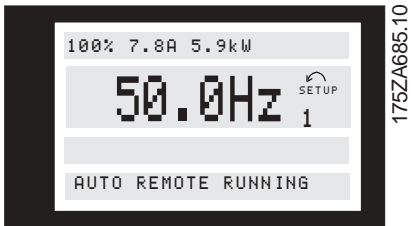

■ **Display mode III:**

This display mode is active as long as the [DISPLAY MODE] key is kept depressed. In the first line, operating data names and units of operating data are displayed. In the second line, operating data 2 remains unchanged. When the key is released, the different operating data values are shown.

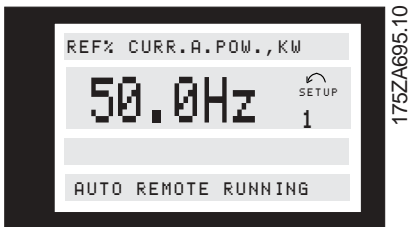

■ **Display mode IV:**

This display mode is only active in connection with local reference, see also *Reference handling*. In this display mode, the reference is determined via the [+/-] keys and control is carried out by means of the keys underneath the indicator lamps. The first line indicates the required reference. The third line gives the relative value of the present output frequency at any given time in relation to the maximum frequency. The display is in the form of a bar graph.

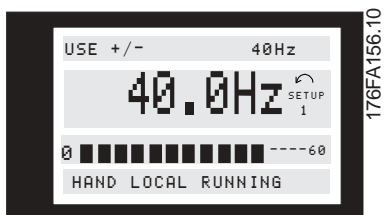

■ Navigation between display modes

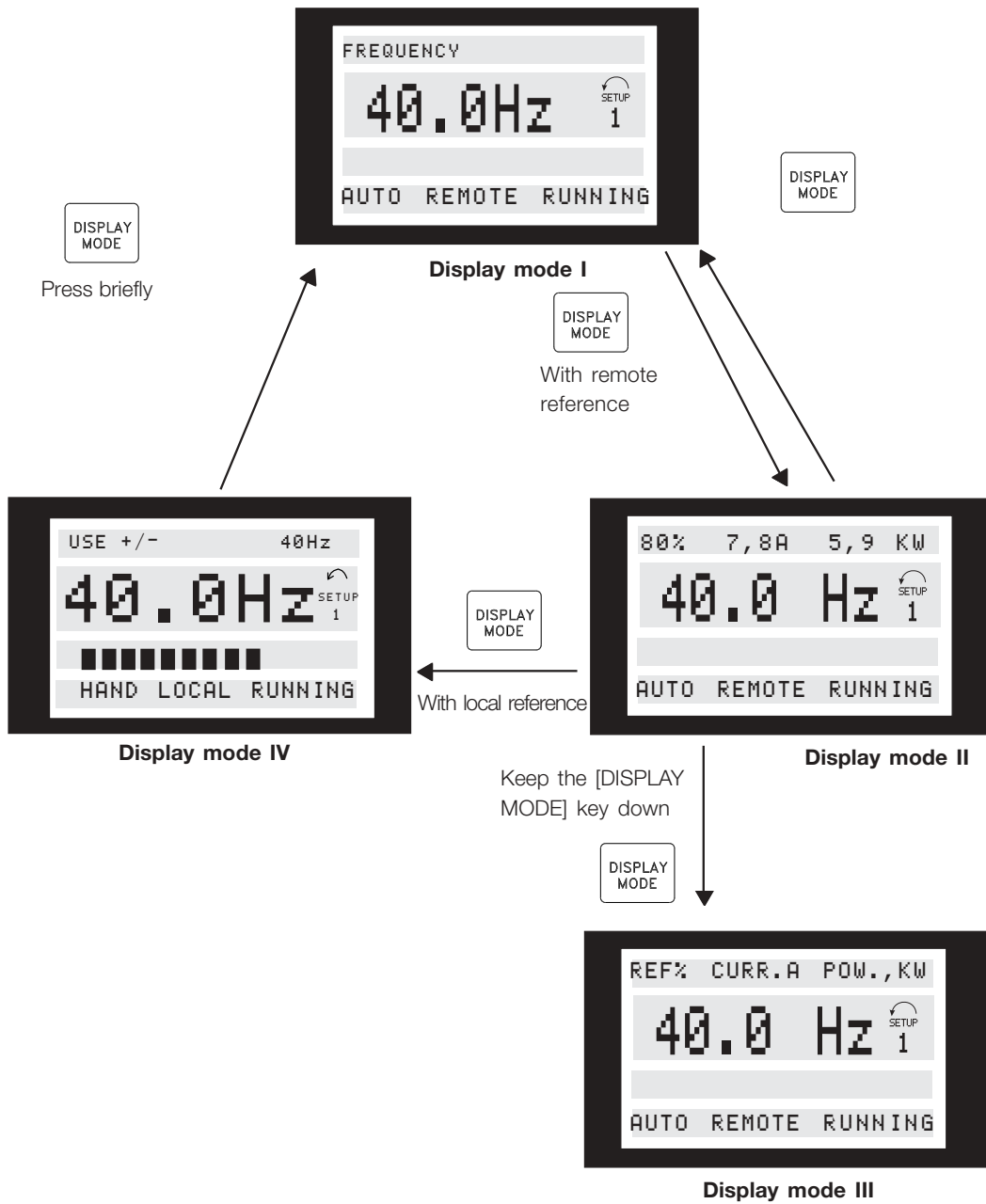

Programming

175ZA697.10

### ■ Changing data

Regardless of whether a parameter has been selected under the Quick menu or the Extended menu, the procedure for changing data is the same. Pressing the [CHANGE DATA] key allows change of the selected parameter, and the underlining in line 4 will flash on the display.

The procedure for changing data depends on whether the selected parameter represents a numerical data value or a functional value.

If the chosen parameter represents a numeric data value, the first digit can be changed by means of the [+/-] keys. If the second digit is to be changed, first move the cursor by using the [<>] keys, then change the data value using the [+/-] keys.

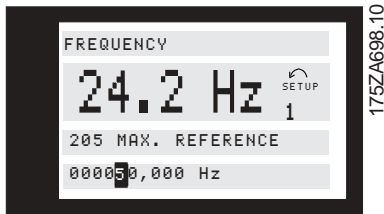

The selected digit is indicated by a flashing cursor. The bottom display line gives the data value that will be entered (saved) when signing off by pressing the [OK] button. Use [CANCEL] to cancel the change.

If the selected parameter is a functional value, the selected text value can be changed by means of the [+/-] keys.

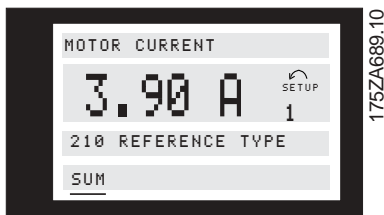

The functional value flashes until signing off by pressing the [OK] button. The functional value has now been selected. Use [CANCEL] to cancel the change.

### ■ Infinitely variable change of numeric data value

If the chosen parameter represents a numeric data value, a digit is first selected by means of the [<>] keys.

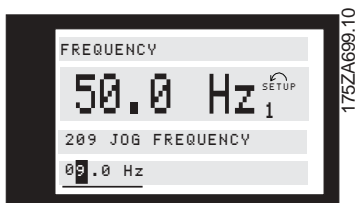

Then the chosen digit is changed infinitely by means of the [+/-] keys:

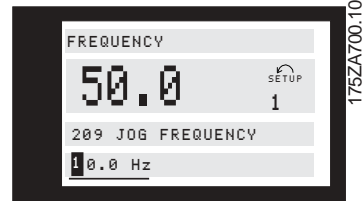

The chosen digit flashes. The bottom display line shows the data value that will be entered (saved) when signing off with [OK].

### ■ Changing of data value, step-by-step

Certain parameters can be changed both step by step and infinitely variably. This applies to *Motor power* (parameter 102), *Motor voltage* (parameter 103) and *Motor frequency* (parameter 104).

This means that the parameters are changed both as a group of numeric data values and as numeric data values infinitely variably.

### ■ Manual initialisation

Disconnect from mains and hold the [DISPLAY MODE] + [CHANGE DATA] + [OK] keys down while at the same time reconnecting the mains supply. Release the keys; the frequency converter has now been programmed for the factory setting.

The following parameters are not zeroed by means of manual initialisation:

Parameter	500, <i>Protocol</i>
	600, <i>Operating hours</i>
	601, <i>hours run</i>
	602, <i>kWh counter</i>
	603, <i>Number of power-ups</i>
	604, <i>Number of overtemperatures</i>
	605, <i>Number of overvoltages</i>

It is also possible to carry out initialisation via parameter 620 *Operating mode*.

**■ Quick Menu**

The QUICK MENU key gives access to 12 of the most important setup parameters of the drive. After programming, the drive will, in many cases, be ready for operation. The 12 Quick Menu parameters are

shown in the table below. A complete description of the function is given in the parameter sections of this manual.

Quick Menu Item Number	Parameter Name	Description
1	001 Language	Selects language used for all displays.
2	102 Motor Power	Sets output characteristics of drive based on kW size of motor.
3	103 Motor Voltage	Sets output characteristics of drive based on voltage of motor.
4	104 Motor Frequency	Sets output characteristics of drive based on nominal frequency of motor. This is typically equal to line frequency.
5	105 Motor Current	Sets output characteristics of drive based on nominal current in amps of motor.
6	106 Motor Nominal Speed	Sets output characteristics of drive based on nominal full load speed of motor.
7	201 Minimum Frequency	Sets minimum controlled frequency at which motor will run.
8	202 Maximum Frequency	Sets maximum controlled frequency at which motor will run.
9	206 Ramp Up Time	Sets time to accelerate motor from 0 Hz to nominal motor frequency set in Quick Menu Item 4.
10	207 Ramp Down Time	Sets time to decelerate motor from nominal motor frequency set in Quick Menu Item 4 to 0 Hz.
11	323 Relay1 Function	Sets function of high voltage Form C relay.
12	326 Relay 2 Function	Sets function of low voltage Form A relay.

---

**■ Parameter Data**

Enter or change parameter data or settings in accordance with the following procedure.

1. Press Quick Menu key.
2. Use '+' and '-' keys to find parameter you choose to edit.
3. Press Change Data key.
4. Use '+' and '-' keys to select correct parameter setting. To move to a different digit within parameter, use < and > arrows. *Flashing cursor indicates digit selected to change.*
5. Press Cancel key to disregard change, or press OK key to accept change and enter new setting.

**Example of Changing Parameter Data**

Assume parameter 206, *Ramp Up Time*, is set at 60 seconds. Change the ramp up time to 100 seconds in accordance with the following procedure.

1. Press Quick Menu key.
2. Press '+' key until you reach Parameter 206, *Ramp Up Time*.
3. Press Change Data key.
4. Press < key twice – hundreds digit will flash.
5. Press '+' key once to change hundreds digit to '1.'
6. Press > key to change to tens digit.
7. Press '-' key until '6' counts down to '0' and setting for *Ramp Up Time* reads '100 s.'
8. Press OK key to enter new value into drive controller.

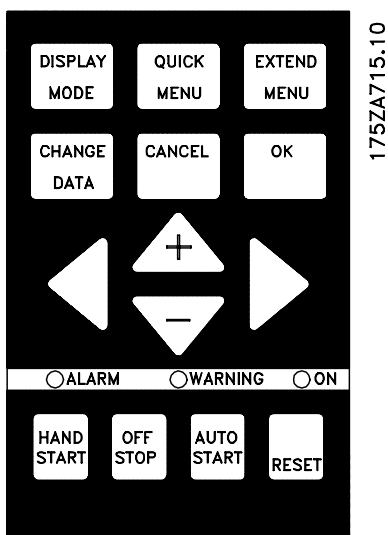

**NB!:** Programming of extended parameters functions available through EXTENDED MENU key is done in accordance with same procedure as described for Quick Menu functions.

---

### ■ Programming

EXTEND  
MENU

Using the [EXTEND MENU] key, it is possible to have access to all the parameters for the frequency converter.

### ■ Operation and Display 001-017

This parameter group allows to set up parameters such as language, display readout and the possibility of making the function keys on the control unit inactive.

#### 001 Language

##### (LANGUAGE)

##### Value:

★English (ENGLISH)	[0]
German (DEUTSCH)	[1]
French (FRANCAIS)	[2]
Danish (DANSK)	[3]
Spanish (ESPAÑOL)	[4]
Italian (ITALIANO)	[5]
Swedish (SVENSKA)	[6]
Dutch (NEDERLANDS)	[7]
Portuguese (PORTUGUESA)	[8]
Finnish (SUOMI)	[9]

State when delivered may vary from factory setting.

##### Function:

The choice in this parameter defines the language to be used on the display.

##### Description of choice:

There is a choice of the languages indicated.

### ■ The Setup configuration

The frequency converter has four Setups (parameter Setups) that can be programmed independently of each other. The active Setup can be selected in parameter 002 *Active Setup*. The active Setup number will be shown in the display under "Setup". It is also possible to set the frequency converter to Multi-Setup to allow switching of Setups with the digital inputs or serial communication.

Setup shifts can be used in systems where, one Setup is used during the day and another at night.

Parameter 003 *Copying of Setups* enables copying from one Setup to another.

★ = factory setting. () = display text [] = value for use in communication via serial communication port

By means of parameter 004 *LCP copy*, all Setups can be transferred from one frequency converter to another by moving the control panel. First all parameter values are copied to the control panel. This can then be moved to another frequency converter, where all parameter values can be copied from the control unit to the frequency converter.

#### 002 Active Setup

##### (ACTIVE SETUP)

##### Value:

Factory Setup (FACTORY SETUP)	[0]
★Setup 1 (SETUP 1)	[1]
Setup 2 (SETUP 2)	[2]
Setup 3 (SETUP 3)	[3]
Setup 4 (SETUP 4)	[4]
MultiSetup (MULTI SETUP)	[5]

##### Function:

The choice in this parameter defines the Setup number you want to control the functions of the frequency converter. All parameters can be programmed in four individual parameter Setups, Setup 1 - Setup 4. In addition, a pre-programmed Setup called the Factory Setup exists. This only allows specific parameters to be changed.

##### Description of choice:

*Factory Setup* [0] contains the parameter values pre-set at the factory. Can be used as a data source if the other Setups are to be returned to a common state. In this case Factory Setup is selected as the active Setup. *Setups 1-4* [1]-[4] are four individual Setups that can be selected as required.

*MultiSetup* [5] is used if remote switching between different Setups is required. Terminals 16/17/29/32/33 and the serial communication port can be used for switching between Setups.

### Connection examples Setup change

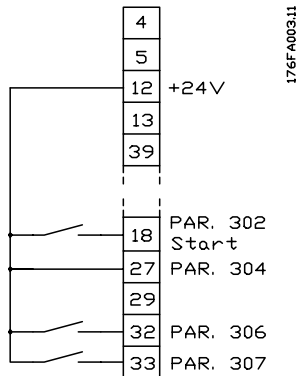

- Selection of Setup using terminals 32 and 33.  
Parameter 306 = Selection of Setup, lsb [4]  
Parameter 307 = Selection of Setup, msb [4]  
Parameter 002 = MultiSetup [5].

### 003 Copying of Setups

#### (SETUP COPY)

##### Value:

- ★No copying (NO COPY) [0]
- Copy active Setup to Setup 1 (COPY TO SETUP 1) [1]
- Copy active Setup to Setup 2 (COPY TO SETUP 2) [2]
- Copy active Setup to Setup 3 (COPY TO SETUP 3) [3]
- Copy active Setup to Setup 4 (COPY TO SETUP 4) [4]
- Copy active Setup to all (COPY TO ALL) [5]

##### Function:

A copy is made from the active Setup selected in parameter 002 Active Setup to the Setup or Setups selected in parameter 003 Copying of Setups.



##### NB!:

Copying is only possible in Stop mode (motor stopped on a Stop command).

##### Description of choice:

The copying starts when the required copying function has been selected and the [OK] key has been pressed. The display indicates when copying is in progress.

### 004 LCP copy

#### (LCP COPY)

##### Value:

- ★No copying (NO COPY) [0]

Upload all parameters

★ = factory setting. () = display text [] = value for use in communication via serial communication port

- (UPLOAD ALL PARAMET.) [1]  
Download all parameters
- (DOWNLOAD ALL PARAM.) [2]  
Download power-independent par.
- (DOWNLOAD SIZE INDEP.) [3]

##### Function:

Parameter 004 LCP copy is used if the integrated copying function of the control panel is to be used. This function is used if all parameter Setups are to be copied from one frequency converter to another by moving the control panel.

##### Description of choice:

Select Upload all parameters [1] if all parameter values are to be transmitted to the control panel.  
Select Download all parameters [2] if all transmitted parameter values are to be copied to the frequency converter on which the control panel has been mounted.  
Select Download power-independent par. [3] if only the power-independent parameters are to be downloaded. This is used if downloading to a frequency converter that has a different rated power than the one from where the parameter Setup originates.



##### NB!:

Uploading/Downloading can only be carried out in the Stop mode.

### ■ Setup of user-defined readout

Parameter 005 Max. value of user-defined readout and 006 Unit for user-defined readout allow users to design their own readout which can be seen if user-defined readout has been selected under display readout. The range is set in parameter 005 Max. value of user-defined readout and the unit is determined in parameter 006 Unit for user-defined readout. The choice of unit decides whether the ratio between the output frequency and the readout is a linear, square or cubed ratio.



### 005 Max. value of user-defined readout (CUSTOM READOUT)

#### Value:

0.01 - 999,999.99 ★ 100.00

#### Function:

This parameter allows a choice of the max. value of the user-defined readout. The value is calculated on the basis of the present motor frequency and the unit selected in parameter 006 *Unit for user-defined readout*. The programmed value is reached when the output frequency in parameter 202 *Output frequency high limit*,  $f_{MAX}$  is reached. The unit also decides whether the ratio between output frequency and readout is linear, square or cubed.

#### Description of choice:

Set the required value for max. output frequency.

### 006 Unit for user-defined readout (CUST. READ. UNIT)

★No unit <sup>1</sup>	[0]	GPM <sup>1</sup>	[21]
% <sup>1</sup>	[1]	gal/s <sup>1</sup>	[22]
rpm <sup>1</sup>	[2]	gal/min <sup>1</sup>	[23]
ppm <sup>1</sup>	[3]	gal/h <sup>1</sup>	[24]
pulse/s <sup>1</sup>	[4]	lb/s <sup>1</sup>	[25]
l/s <sup>1</sup>	[5]	lb/min <sup>1</sup>	[26]
l/min <sup>1</sup>	[6]	lb/h <sup>1</sup>	[27]
l/h <sup>1</sup>	[7]	CFM <sup>1</sup>	[28]
kg/s <sup>1</sup>	[8]	ft <sup>3</sup> /s <sup>1</sup>	[29]
kg/min <sup>1</sup>	[9]	ft <sup>3</sup> /min <sup>1</sup>	[30]
kg/h <sup>1</sup>	[10]	ft <sup>3</sup> /h <sup>1</sup>	[31]
m <sup>3</sup> /s <sup>1</sup>	[11]	ft <sup>3</sup> /min <sup>1</sup>	[32]
m <sup>3</sup> /min <sup>1</sup>	[12]	ft/s <sup>1</sup>	[33]
m <sup>3</sup> /h <sup>1</sup>	[13]	in wg <sup>2</sup>	[34]
m/s <sup>1</sup>	[14]	ft wg <sup>2</sup>	[35]
mbar <sup>2</sup>	[15]	PSI <sup>2</sup>	[36]
bar <sup>2</sup>	[16]	lb/in <sup>2</sup>	[37]
Pa <sup>2</sup>	[17]	HP <sup>3</sup>	[38]
kPa <sup>2</sup>	[18]		
MWG <sup>2</sup>	[19]		
kW <sup>3</sup>	[20]		

Flow and speed units are marked with 1.  
Pressure units with 2, and power units with 3. See figure in next column.

#### Function:

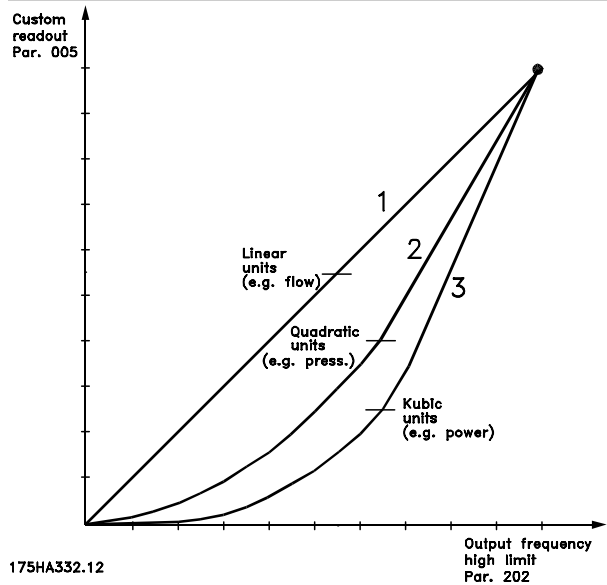

175HA332.12

Select a unit to be shown in the display in connection with parameter 005 *Max. value of user-defined readout*. If units such as flow or speed units are selected, the ratio between readout and output frequency will be a linear one.

If pressure units are selected (bar, Pa, MWG, PSI, etc.), the ratio will be square. If power units (HP, kW) are selected, the ratio will be cubed.

The value and the unit are shown in display mode whenever *User-defined readout* [10] has been selected in one of parameters 007-010 *Display readout*.

#### Description of choice:

Select the required unit for *User-defined readout*.

### 007 Large display readout

#### (LARGE READOUT)

#### Value:

Resulting reference [%] (REFERENCE [%])	[1]
Resulting reference [unit] (REFERENCE [UNIT])	[2]
★Frequency [Hz] (FREQUENCY [HZ])	[3]
% of maximum output frequency [%] (FREQUENCY [%])	[4]
Motor current [A] (MOTOR CURRENT [A])	[5]
Power [kW] (POWER [KW])	[6]
Power [HP] (POWER [HP])	[7]
Output energy [kWh] (ENERGI [UNIT])	[8]
Hours run [Hours] (OURS RUN [H])	[9]
User-defined readout [-] (CUSTOM READ.[UNITS])	[10]
Setpoint 1 [unit] (SETPOINT 1 [UNITS])	[11]
Setpoint 2 [unit] (SETPOINT 2 [UNITS])	[12]
Feedback 1 (FEEDBACK 1 [UNITS])	[13]
Feedback 2 (FEEDBACK 2 [UNITS])	[14]

★ = factory setting. () = display text [] = value for use in communication via serial communication port

Feedback [unit] (FEEDBACK [UNITS])	[15]
Motor voltage [V] (MOTOR VOLTAGE [V])	[16]
DC link voltage [V] (DC VOLTAGE [V])	[17]
Thermal load, motor [%] (THERM.MOTOR LOAD [%])	[18]
Thermal load, VLT [%] (THERM.DRIVE LOAD [%])	[19]
Digital input [Binary code] (DIGITAL INPUT [BIN])	[20]
Analogue input 53 [V] (ANALOG INPUT 53 [V])	[21]
Analogue input 54 [V] (ANALOG INPUT 54 [V])	[22]
Analogue input 60 [mA] (ANALOG INPUT 60 [MA])	[23]
Relay status [binary code] (RELAY STATUS)	[24]
Pulse reference [Hz] (PULSE REFERENCE [HZ])	[25]
External reference [%] (EXT. REFERENCE [%])	[26]
Heat sink temp. [°C] (HEATSINK TEMP [°C])	[27]
Communication option card warning (COMM OPT WARN [HEX])	[28]
LCP display text (FREE PROG.ARRAY)	[29]
Status word (STATUS WORD [HEX])	[30]
Control word (CONTROL WORD [HEX])	[31]
Alarm word (ALARM WORD [HEX])	[32]
PID output [Hz] (PID OUTPUT [HZ])	[33]
PID output [%] (PID OUTPUT [%])	[34]
Real Time Clock (REAL TIME CLOCK)	[40]

**Function:**

This parameter allows a choice of the data value to be shown in the display, line 2, when the frequency converter is turned on. The data values will also be included in the display mode scroll-list. Parameters 008-010 *Small display readout* allow a choice of another three data values, shown in line 1. See the description of the *control unit*.

**Description of choice:**

**No readout** can only be selected in parameters 008-010 *Small display readout*.

**Resulting reference [%]** gives a percentage for the resulting reference in the range from *Minimum reference*, Ref<sub>MIN</sub> to *Maximum reference*, Ref<sub>MAX</sub>. See also *reference handling*.

**Reference [unit]** gives the resulting reference in Hz in *Open loop*. In *Closed loop*, the reference unit is selected in parameter 415 *Process units*.

**Frequency [Hz]** gives the output frequency from the frequency converter.

**% of maximum output frequency [%]** is the present output frequency as a percentage value of parameter 202 *Output frequency high limit*, f<sub>MAX</sub>.

**Motor current [A]** states the phase current of the motor measured as effective value.

**Power [kW]** states the actual power consumed by the motor in kW.

**Power [HP]** states the actual power consumed by the motor in HP.

**Output energy [kWh]** states the energy consumed by the motor since the latest reset was made in parameter 618 *Reset of kWh* counter.

**Hours run [Hours]** states the number of hours that the motor has run since the latest reset in parameter 619 *Reset of hours-run* counter.

**User -defined readout [-]** is a user-defined value, calculated on the basis of the present output frequency and unit, as well as the scaling in parameter 005 *Max. value of user-defined readout*. Select unit in parameter 006 *Unit for user-defined readout*.

**Setpoint 1 [unit]** is the programmed setpoint value in parameter 418 *Setpoint 1*. The unit is decided in parameter 415 *Process units*. See also *Feedback handling*.

**Setpoint 2 [unit]** is the programmed setpoint value in parameter 419 *Setpoint 2*. The unit is decided in parameter 415 *Process units*.

**Feedback 1 [unit]** gives the signal value of the resulting feedback 1 (Term. 53). The unit is decided in parameter 415 *Process units*. See also *Feedback handling*.

**Feedback 2 [unit]** gives the signal value of the resulting feedback 2 (Term. 53). The unit is decided in parameter 415 *Process units*.

**Feedback [unit]** gives the resulting signal value using the unit/scaling selected in parameter 413 *Minimum feedback*, FB<sub>MIN</sub>, 414 *Maximum feedback*, FB<sub>MAX</sub> and 415 *Process units*.

**Motor voltage [V]** states the voltage supplied to the motor.

**DC link voltage [V]** states the intermediate circuit voltage in the frequency converter.

**Thermal load, motor [%]** states the calculated/estimated thermal load on the motor. 100% is the cut-out limit. See also parameter 117 *Motor thermal protection*.

**Thermal load, VLT [%]** states the calculated/estimated thermal load on the frequency converter. 100% is the cut-out limit.

**Digital input [Binary code]** states the signal status from the 8 digital inputs (16, 17, 18, 19, 27, 29, 32 and 33). Terminal 16 corresponds to the bit at the far left. '0' = no signal, '1' = connected signal.

**Analogue input 53 [V]** states the voltage value on terminal 53.

**Analogue input 54 [V]** states the voltage value on terminal 54.

**Analogue input 60 [mA]** states the voltage value on terminal 60.

★ = factory setting. () = display text [] = value for use in communication via serial communication port

**Relay status [binary code]** indicates the status of each relay. The left (most significant) bit indicates relay 1 followed by 2 and 6 through 9. A "1" indicates the relay is active, a "0" indicates inactive. Parameter 007 uses an 8-bit word with the last two positions not used. Relays 6-9 are provided with the cascade controller and four relay option cards

**Pulse reference [Hz]** states a pulse frequency in Hz connected to terminal 17 or terminal 29.

**External reference [%]** gives the sum of the external references as a percentage (the sum of analogue/pulse/serial communication) in the range from *Minimum reference*, Ref<sub>MIN</sub> to *Maximum reference*, Ref<sub>MAX</sub>.

**Heat sink temp. [°C]** states the present heat sink temperature of the frequency converter. The cut-out limit is 90 ± 5°C; cutting back in occurs at 60 ± 5°C.

**Communication option card warning [Hex]** gives a warning word if there is a fault on the communication bus. This is only active if communication options have been installed. Without communication options, 0 Hex is displayed.

**LCP display text** shows the text programmed in parameter 533 *Display text 1* and 534 *Display text 2* via LCP or the serial communication port.

### LCP procedure for entering text

After selecting *Display Text* in parameter 007, select display line parameter (533 or 534) and press the **CHANGE DATA** key. Enter text directly into the selected line by using **UP, DN & LEFT, RIGHT** arrow keys on the LCP. The UP and DN arrow keys scroll through the available characters. The Left and Right arrow keys move the cursor through the line of text. To lock in the text, press the **OK** key when the line of text is completed. The **CANCEL** key will cancel the text. The available characters are:  
 A B C D E F G H I J K L M N O P Q R S T U V W X Y Z  
 Æ Ø Å Ä Ö Ü È Ì Ù è . / - ( ) 0 1 2 3 4 5 6 7 8 9 'space'  
 'space' is the default value of parameter 533 & 534. To erase a character that has been entered, it must be replaced with 'space'.

**Status word** displays the actual drive status word (see parameter 608).

**Control word** displays the actual control word (see parameter 607).

**Alarm word** displays the actual alarm word.

**PID output** shows the calculated PID output in the display in either Hz [33] or percentage of max frequency [34].

### Real time clock

Real time clock can show the current time and date and weekday. The available digits stipulate how comprehensive the readout can be. E.g if only the real time clock readout is used in the top line (parameter 008, 009 or 010) the following is

shown: WD YYYY/MM/DD/ HH.MM. See table below for further reference:

Available digits	Format	Ex.
6	hh.mm	11.29
8	WW hh.mm	WE 11.29
13	WW YYMMDD hh.mm	WE 040811 11.29
20	WW YYYY/MM/DD hh.mm	WE 2004/08/11 11.29

### 008 Small display readout 1.1

#### (SMALL READOUT 1)

#### Value:

See parameter 007 *Large display readout*

★ Reference [Unit] [2]

#### Function:

This parameter enables a choice of the first of three data values to be shown on the display, line 1, position 1. This is a useful function, i.a. when setting the PID regulator, in order to see how the process reacts to a change of reference.

For display read-outs, press the [DISPLAY MODE] button. Data option *LCP display text* [29] cannot be selected with *Small display readout*.

#### Description of choice:

There is a choice of 33 different data values, see parameter 007 *Large display readout*.

### 009 Small display readout 1.2

#### (SMALL READOUT 2)

#### Value:

See parameter 007 *Large display readout*

★Motorcurrent [A] [5]

#### Function:

See the functional description for parameter 008 *Small display readout*. Data option *LCP display text* [29] cannot be selected with *Small display readout*.

#### Description of choice:

There is a choice of 33 different data values, see parameter 007 *Large display readout*.

★ = factory setting. () = display text [] = value for use in communication via serial communication port

### 010 Small display readout 1.3

#### (SMALL READOUT 3)

##### Value:

See parameter 007 *Large display readout*

★Power [kW] [6]

##### Function:

See the functional description for parameter 008 *Small data readout*. Data option *LCP display text* [29] cannot be selected with *Small display readout*.

##### Description of choice:

There is a choice of 33 different data values, see parameter 007 *Large display readout*.

### 011 Unit of local reference

#### (UNIT OF LOC REF)

##### Value:

Hz (HZ) [0]

★% of output frequency range (%) (% OF FMAX) [1]

##### Function:

This parameter decides the local reference unit.

##### Description of choice:

Choose the required unit for local reference.

### 012 Hand start on LCP

#### (HAND START BTTN)

##### Value:

Disable (DISABLE) [0]

★Enable (ENABLE) [1]

##### Function:

This parameter allows selection/deselection of the Hand start key on the control panel.

##### Description of choice:

If *Disable* [0] is selected in this parameter, the [HAND START] key will be inactive.

### 013 OFF/STOP on LCP

#### (STOP BUTTON)

##### Value:

Disable (DISABLE) [0]

★Enable (ENABLE) [1]

##### Function:

This parameter allows selection/deselection of the local stop key on the control panel.

★ = factory setting. () = display text [] = value for use in communication via serial communication port

##### Description of choice:

If *Disable* [0] is selected in this parameter, the [OFF/ STOP] key will be inactive.



##### NB!:

If *Disable* is selected, the motor cannot be stopped by means of the [OFF/STOP] key.

### 014 Auto start on LCP

#### (AUTO START BTTN)

##### Value:

Disable (DISABLE) [0]

★Enable (ENABLE) [1]

##### Function:

This parameter allows selection/deselection of the auto start key on the control panel.

##### Description of choice:

If *Disable* [0] is selected in this parameter, the [AUTO START] key will be inactive.

### 015 Reset on LCP

#### (RESET BUTTON)

##### Value:

Disable (DISABLE) [0]

★Enable (ENABLE) [1]

##### Function:

This parameter allows selection/deselection of the reset key on the control panel.

##### Description of choice:

If *Disable* [0] is selected in this parameter, the [RESET] key will be inactive.



##### NB!:

Only select *Disable* [0] if an external reset signal has been connected via the digital inputs.

### 016 Lock for data change

#### (DATA CHANGE LOCK)

##### Value:

★Not locked (NOT LOCKED) [0]

Locked (LOCKED) [1]

##### Function:

This parameter allows the control panel to be "locked", which means that it is not possible to carry out data modifications via the control unit.

**Description of choice:**

If *Locked* [1] is selected, data modifications in the parameters cannot be made, although it will still be possible to carry out data modifications via the bus. Parameters 007-010 *Display readout* can be changed via the control panel.

It is also possible to lock for data modifications in these parameters by means of a digital input, see parameters 300-307 *Digital inputs*.

**017 Operating state at power up, local control**

**(POWER UP ACTION)**

**Value:**

- ★Auto restart (AUTO RESTART) [0]
- OFF/Stop (OFF/STOP) [1]

**Function:**

Setting of the desired operating mode when the mains voltage is reconnected.

**Description of choice:**

*Auto restart* [0] is selected if the frequency converter is to start up in the same start/stop condition as immediately before power to the frequency converter is cut off. *OFF/Stop* [1] is selected if the frequency converter is to remain stopped when the mains voltage is connected, until a start command is active. To restart, activate the key [HAND START] or [AUTO START] by using the control panel.



**NB!:**

If [HAND START] or [AUTO START] cannot be activated by the keys on the control panel (see parameter 012/014 *Hand/Auto start on LCP*) the motor will not be able to restart if *OFF/Stop* [1] is selected. If Handstart or Autostart has been programmed for activation via the digital inputs, the motor will not be able to restart if *OFF/Stop* [1] is selected.

★ = factory setting. () = display text [] = value for use in communication via serial communication port

### ■ Load and Motor 100-117

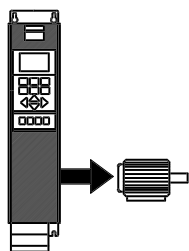

This parameter group allows the configuration of regulation parameters and the choice of torque characteristics to which the frequency converter is to be adapted.

The motor nameplate data must be

set and automatic motor adaptation can be carried out. In addition, DC brake parameters can be set and the motor thermal protection can be activated.

### ■ Configuration

The selection of configuration and torque characteristics influences the parameters that can be seen in the display. If *Open loop* [0] is selected, all parameters relating to PID regulation will be hidden.

Consequently, the user is only able to see the parameters that are of significance for a given application.

#### 100 Configuration

##### (CONFIG. MODE)

##### Value:

- ★ Open loop (OPEN LOOP) [0]
- Closed loop (CLOSED LOOP) [1]

##### Function:

This parameter is used for selecting the configuration to which the frequency converter is to be adapted.

##### Description of choice:

If *Open loop* [0] is selected, normal speed control is obtained (without feedback signal), i.e. if the reference is changed, the motor speed will change.

If *Closed loop* [1] is selected, the internal process regulator is activated to enable accurate regulation in relation to a given process signal.

The reference (setpoint) and the process signal (feedback) can be set to a process unit as programmed in parameter 415 *Process units*. See *Feedback handling*.

#### 101 Torque characteristics

##### (VT CHARACT)

##### Value:

- ★ Automatic Energy Optimisation (AEO FUNCTION) [0]
- Parallel motors (MULTIPLE MOTORS) [1]

##### Function:

This parameter allows a choice of whether the frequency converter has one or several motors connected to it.

##### Description of choice:

If Automatic Energy Optimisation [0] has been selected, only one motor may be connected to the frequency converter. The AEO function ensures that the motor obtains its maximum efficiency and minimises motor interference. Parameter 118 makes it possible to set the power factor (Cos  $\varphi$ ) which is used by the AEO function.

Select *Parallel motors* [1] if more than one motor is connected to the output in parallel. See the description under parameter 108 *Start voltage of parallel motors* regarding the setting of parallel motor start voltages.

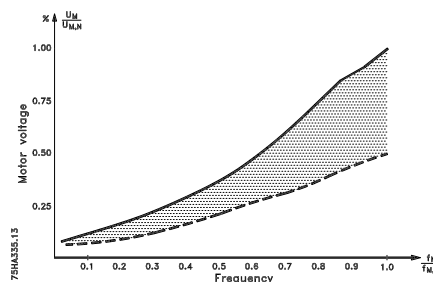

#### 102 Motor power, P<sub>M,N</sub>

##### (MOTOR POWER)

##### Value:

- 0.25 kW (0.25 KW) [25]
- 0.37 kW (0.37 KW) [37]
- 0.55 kW (0.55 KW) [55]
- 0.75 kW (0.75 KW) [75]
- 1.1 kW (1.10 KW) [110]
- 1.5 kW (1.50 KW) [150]
- 2.2 kW (2.20 KW) [220]
- 3 kW (3.00 KW) [300]
- 4 kW (4.00 KW) [400]
- 5,5 kW (5.50 KW) [550]
- 7,5 kW (7.50 KW) [750]
- 11 kW (11.00 KW) [1100]
- 15 kW (15.00 KW) [1500]
- 18.5 kW (18.50 KW) [1850]
- 22 kW (22.00 KW) [2200]
- 30 kW (30.00 KW) [3000]

★ = factory setting. () = display text [] = value for use in communication via serial communication port

37 kW (37.00 KW)	[3700]
45 kW (45.00 KW)	[4500]
55 kW (55.00 KW)	[5500]
75 kW (75.00 KW)	[7500]
90 kW (90.00 KW)	[9000]
110 kW (110.00 KW)	[11000]
132 kW (132.00 KW)	[13200]
160 kW (160.00 KW)	[16000]
200 kW (200.00 KW)	[20000]
250 kW (250.00 KW)	[25000]
300 kW (300.00 KW)	[30000]
315 kW (315.00 KW)	[31500]
355 kW (355.00 KW)	[35500]
400 kW (400.00 KW)	[40000]
450 kW (450.00 KW)	[45000]
500 kW (500.00 KW)	[50000]
550 kW (550.00 KW)	[55000]

★ Depends on the unit

### Function:

This is where to select the kW value  $P_{M,N}$  that corresponds to the rated power of the motor. At the works, a rated kW value  $P_{M,N}$  has been selected that depends on the type of unit.

### Description of choice:

Select a value that equals the nameplate data on the motor. There are 4 possible undersizes or 1 oversize in comparison with the factory setting. Also, alternatively it is possible to set the value for motor power as an infinitely variable value, see the procedure for *Infinitely variable change of numeric data value*.

### 103 Motor voltage, $U_{M,N}$

#### (MOTOR VOLTAGE)

#### Value:

200 V	[200]
208 V	[208]
220 V	[220]
230 V	[230]
240 V	[240]
380 V	[380]
400 V	[400]
415 V	[415]
440 V	[440]
460 V	[460]
480 V	[480]
500 V	[500]
550 V	[550]
575 V	[575]
600 V	[600]

★ Depends on the unit

### Function:

This is where the rated motor voltage  $U_{M,N}$  is set for either star Y or delta  $\Delta$ .

### Description of choice:

Select a value that equals the nameplate data on the motor, regardless of the mains voltage of the frequency converter. Furthermore, alternatively it is possible to set the value of the motor voltage infinitely variably. Also refer to the procedure for *infinitely variable change of numeric data value*.



### NBI:

Changing parameters 102, 103 or 104 will automatically reset parameters 105 and 106 to default values. If changes are made to parameters 102, 103 or 104, go back and reset parameters 105 and 106 to correct values.

### 104 Motor frequency, $f_{M,N}$

#### (MOTOR FREQUENCY)

#### Value:

★ 50 Hz (50 HZ)	[50]
60 Hz (60 HZ)	[60]

### Function:

This is where the rated motor frequency  $f_{M,N}$  is selected.

### Description of choice:

Select a value that equals the nameplate data on the motor. Furthermore, it is also possible to set the value for motor frequency infinitely variably in the 24-1000 Hz range.

### 105 Motor current, $I_{M,N}$ (MOTOR CURRENT)

#### (MOTOR CURRENT)

#### Value:

0.01 -  $I_{VLT,MAX}$  A      ★ Depends on the unit

### Function:

The rated motor current  $I_{M,N}$  forms part of the frequency converter calculations i.a. of torque and motor thermal protection. Set the motor current  $I_{VLT,N}$ , taking into account the star Y or delta connected motor.

### Description of choice:

Set a value that equals the nameplate data on the motor.

**NB!:**

It is important to enter the correct value, since this forms part of the VVC + control feature.

**106 Rated motor speed,  $n_{M,N}$** 
**(MOTOR NOM. SPEED)**
**Value:**

100 -  $f_{M,N} \times 60$  (max. 60000 rpm)

★Depends on parameter 102 *Motor power*,  $P_{M,N}$

**Function:**

This is where the value is set that corresponds to the rated motor speed  $n_{M,N}$ , which can be seen from the nameplate data.

**Description of choice:**

Choose a value that corresponds to the motor nameplate data.

**NB!:**

It is important to set the correct value, since this forms part of the VVC + control feature.

The max. value equals  $f_{M,N} \times 60$ .

$f_{M,N}$  is set in parameter 104 *Motor frequency*,  $f_{M,N}$ .

**107 Automatic motor adaptation, AMA**
**(AUTO MOTOR ADAPT)**
**Value:**

★Optimisation disable (NO AMA)	[0]
Automatic adaptation (RUN AMA)	[1]
Automatic adaptation with LC-filter (RUN AMA WITH LC-FILT)	[2]

**Function:**

Automatic motor adaptation is a test algorithm that measures the electrical motor parameters at motor standstill. This means that AMA itself does not supply any torque.

AMA is useful when commissioning systems, where the user wants to optimise the adjustment of the frequency converter to the motor applied. This feature is used in particular where the factory setting does not adequately cover the motor in question.

For the best adjustment of the frequency converter, it is recommended to carry out AMA on a cold motor.

It must be noted that repeated AMA runs may lead to a heating of the motor that will result in an increase of the stator resistance  $R_S$ . However, this is not normally critical.

**NB!:**

It is important to run AMA with any motors  $\geq 55$  kW/ 75 HP

It is possible via parameter 107 *Automatic motor adaptation*, AMA to choose whether a complete automatic motor adaptation *Automatic adaptation* [1] is to be carried out, or whether reduced automatic motor adaptation *Automatic adaptation with LC-filter* [2] is to be made.

It is only possible to carry out the reduced test if a LC-filter has been placed between the frequency converter and the motor. If a total setting is required, the LC-filter can be removed and, after completion of the AMA, it can be reinstalled. In *Automatic optimisation with LC-filter* [2] there is no test of motor symmetry and of whether all motor phases have been connected. The following must be noted when the AMA function is used:

- For AMA to be able to determine the motor parameters optimally, the correct nameplate data for the motor connected to the frequency converter must be entered in parameters 102 to 106.
- The duration of a total automatic motor adaptation varies from a few minutes to approx. 10 minutes for small motors, depending on the rating of the motor used (the time for a 7.5 kW motor, for example, is approx. 4 minutes).
- Alarms and warnings will be shown in the display if faults occur during motor adaptation.
- AMA can only be carried out if the rated motor current of the motor is min. 35% of the rated output current of the frequency converter.
- If automatic motor adaptation is to be discontinued, press the [OFF/STOP] key.

**NB!:**

AMA is not allowed on motors connected in parallel.

**Description of choice:**

Select *Automatic adaptation* [1] if the frequency converter is to carry out a complete automatic motor adaptation.

Select *Automatic adaptation with LC-filter* [2] if a LC-filter has been placed between the frequency converter and the motor.

**Procedure for automatic motor adaptation:**

1. Set the motor parameters in accordance with the motor nameplate data given in parameters 102-106 *Nameplate data*.

★ = factory setting. () = display text [] = value for use in communication via serial communication port



2. Connect 24 V DC (possibly from terminal 12) to terminal 27 on the control card.
3. Select Automatic adaptation [1] or Automatic adaptation with LC-filter [2] in parameter 107 *Automatic motor adaptation, AMA*.
4. Start up the frequency converter or connect terminal 18 (start) to 24 V DC (possibly from terminal 12).
5. After a normal sequence, the display reads: AMA STOP. After a reset, the frequency converter will be ready to start operation again.

**If the automatic motor adaptation is to be stopped:**

1. Press the [OFF/STOP] key.

**If there is a fault, the display reads: ALARM 22**

1. Press the [Reset] key.
2. Check for possible causes of the fault in accordance with the alarm message. See *List of warnings and alarms*.

**If there is a warning, the display reads:**

**WARNING 39-42**

1. Check for possible causes of the fault in accordance with the warning. See *List of warnings and alarms*.
2. Press the [CHANGE DATA] key and select "Continue" if AMA is to continue despite the warning, or press the [OFF/STOP] key to stop the automatic motor adaptation.

### 108 Start voltage of parallel motors

#### (MULTIM.START VOLT)

**Value:**

0.0 - parameter 103 *Motor voltage, U<sub>M,N</sub>*

★ Depends on par. 103 *Motor voltage, U<sub>M,N</sub>*

**Function:**

This parameter specifies the start-up voltage of the permanent VT characteristics at 0 Hz for motors connected in parallel.

The start-up voltage represents a supplementary voltage input to the motor. By increasing the start-up voltage, motors connected in parallel receive a higher start-up torque. This is used especially for small motors (< 4.0 kW) connected in parallel, as they have a higher stator resistance than motors above 5.5 kW.

This function is only active if *Parallel motors* [1] has been selected in parameter 101 *Torque characteristics*.

**Description of choice:**

Set the start-up voltage at 0 Hz. The maximum voltage depends on parameter 103 *Motor voltage, U<sub>M,N</sub>*.

### 109 Resonance damping

#### (RESONANCE DAMP.)

**Value:**

0 - 500 %

★ 100 %

**Function:**

High-frequency electric resonance problems between the frequency converter and the motor can be eliminated by adjusting the resonance damping.

**Description of choice:**

Adjust the damping percentage until the motor resonance has disappeared.

### 110 High break-away torque

#### (HIGH START TORQ.)

**Value:**

0.0 (OFF) - 0.5 sec.

★ OFF

**Function:**

In order to secure a high starting torque, the maximum torque for max. 0.5 sec. is allowed. However, the current is limited by the protection limit of the frequency converter (inverter). 0 sec. corresponds to no high break-away torque.

**Description of choice:**

Set the necessary time in which a high starting torque is desired.

### 111 Start delay

#### (START DELAY)

**Value:**

0.0 - 120.0 sec.

★ 0.0 sec.

**Function:**

This parameter enables a delay of the starting time after the conditions for start have been fulfilled. When the time has passed, the output frequency will start by ramping up to the reference.

**Description of choice:**

Set the desired time until acceleration is to begin.

### 112 Motor preheater

#### (MOTOR PREHEAT)

**Value:**

★Disable (DISABLE)

[0]

Enable (ENABLE)

[1]

★ = factory setting. () = display text [] = value for use in communication via serial communication port

### Function:

The motor preheater ensures that no condensate develops in the motor at stop. This function can also be used to evaporate condensed water in the motor. The motor preheater is only active during stop.

### Description of choice:

Select *Disable* [0] if this function is not required. Select *Enable* [1] to activate motor preheating. The DC current is set in parameter 113 *Motor preheater DC current*.

### 113 Motor preheater DC current (PREHEAT DC-CURR.)

#### Value:

0 - 100 % ★ 50 %

The maximum value depends on the rated motor current, parameter 105 *Motor current*,  $I_{M,N}$ .

### Function:

The motor can be preheated at stop by means of a DC current to prevent moisture from entering the motor.

VLT 6152-6602, 380-460 V and VLT 6102-6652, 525-600 V work with a reduced DC current. The level can, depending on motor selection, be down to 80%.

### Description of choice:

The motor can be preheated by means of a DC current. At 0%, the function is inactive; at a value higher than 0%, a DC current will be supplied to the motor at stop (0 Hz). This function can also be used to generate a holding torque.



If too high a DC current is supplied for too long, the motor can be damaged.

### ■ DC braking

In DC braking, the motor receives a DC current that brings the shaft to a halt. Parameter 114 *DC braking current*, decides the DC braking current as a percentage of the rated motor current  $I_{M,N}$ .

In parameter 115 *DC braking time*, the DC braking time is selected, and in parameter 116 *DC brake cut-in frequency*, the frequency is selected at which DC braking becomes active.

If terminal 19 or 27 (parameter 303/304 *Digital input*) has been programmed to *DC braking inverse* and shifts from logic "1" to logic "0", the DC braking will be activated.

When the start signal on terminal 18 changes from logic "1" to logic "0", the DC braking will be

activated when the output frequency becomes lower than the brake coupling frequency.



### NBI:

The DC brake is not to be used if the inertia of the motor shaft is more than 20 times the inertia of the motor itself.

### 114 DC braking current

#### (DC BRAKE CURRENT)

#### Value:

$0 - \frac{I_{VLT,MAX}}{I_{M,N}} \times 100$  [%] ★ 50 %

The maximum value depends on the rated motor current. If the DC braking current is active, the frequency converter has a switching frequency of 4 kHz.

### Function:

This parameter is used for setting the DC braking current that is activated upon a stop when the DC brake frequency set in parameter 116, *DC brake cut-in frequency* has been reached, or if DC brake inverse is active via terminal 27 or via the serial communication port. The DC braking current will be active for the duration of the DC braking time set in parameter 115 *DC braking time*.

VLT 6152-6602, 380-460 V and VLT 6102-6652, 525-600 V work with a reduced DC current. The level can, depending on motor selection, be down to 80%.

### Description of choice:

To be set as a percentage value of the rated motor current  $I_{M,N}$  set in parameter 105 *Motor current*,  $I_{VLT,N}$ . 100% DC braking current corresponds to  $I_{M,N}$ .



Make sure not to supply too high a braking current for too long. The motor will be damaged because of mechanical overload or the heat generated in the motor.

### 115 DC braking time

#### (DC BRAKE TIME)

#### Value:

0.0 - 60.0 sec. ★ 10 sec.

### Function:

This parameter is for setting the DC braking time for which the DC braking current (parameter 113) is to be active.

### Description of choice:

Set the desired time.

**116 DC brake cut-in frequency**

**(DC BRAKE CUT-IN)**

**Value:**

0.0 (OFF) - par. 202  
*Output frequency high limit, f<sub>MAX</sub>* ★ OFF

**Function:**

This parameter is used for setting the DC brake cut-in frequency at which DC braking is to be activated in connection with a stop command.

**Description of choice:**

Set the desired frequency.

**117 Motor thermal protection**

**(MOT. THERM PROTEC)**

**Value:**

- No protection (NO PROTECTION) [0]
- Thermistor warning (THERMISTOR WARNING) [1]
- Thermistor trip (THERMISTOR FAULT) [2]
- ETR Warning 1 (ETR WARNING 1) [3]
- ★ETR Trip 1 (ETR TRIP 1) [4]
- ETR Warning 2 (ETR WARNING 2) [5]
- ETR Trip 2 (ETR TRIP 2) [6]
- ETR Warning 3 (ETR WARNING 3) [7]
- ETR Trip 3 (ETR TRIP 3) [8]
- ETR Warning 4 (ETR WARNING 4) [9]
- ETR Trip 4 (ETR TRIP 4) [10]

**Function:**

The frequency converter is able to monitor the motor temperature in two different ways:

- Via a thermistor sensor fitted to the motor. The thermistor is connected to one of the analog input terminals 53 and 54.
- Calculation of the thermal load (ETR - Electronic Thermal Relay), based on the current load and the time. This is compared with the rated motor current  $I_{M,N}$  and the rated motor frequency  $f_{M,N}$ . The calculations made take into account the need for a lower load at lower speeds because of less cooling in the motor itself.

ETR functions 1-4 do not start calculating the load until there is a switch-over to the Setup in which they were selected. This enables the use of the ETR function, even where two or several motors alternate.

**Description of choice:**

Select *No protection* [0] if no warning or tripping is required when the motor is overloaded.  
 Select *Thermistor warning* [1] if a warning is desired when the connected thermistor gets too hot.

★ = factory setting. () = display text [] = value for use in communication via serial communication port

Select *Thermistor trip* [2] if cutting out (trip) is desired when the connected thermistor overheats.

Select *ETR Warning 1-4*, if a warning is to come up on the display when the motor is overloaded according to the calculations.

The frequency converter can also be programmed to give off a warning signal via one of the digital outputs. Select *ETR Trip 1-4* if tripping is desired when the motor is overloaded according to the calculations.

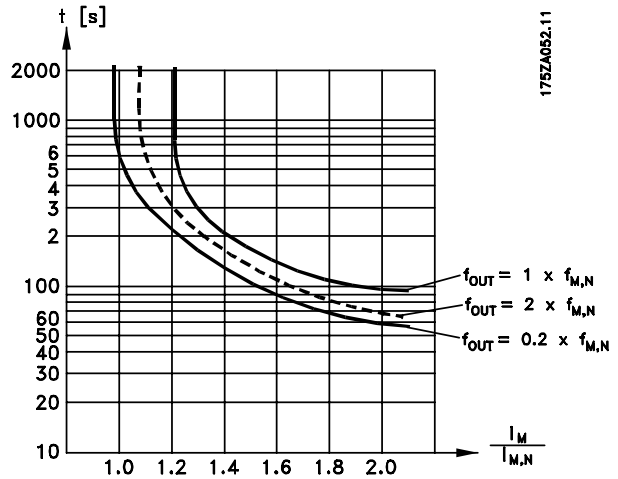

**NB!:**

In UL / cUL applications ETR provides class 20 motor overload protection in accordance with National Electrical Code.

**118 Motor power factor (Cos φ)**

**(MOTOR PWR FACT)**

**Value:**

0.50 - 0.99 ★ 0.75

**Function:**

This parameter calibrates and optimizes the AEO function for motors of different power factor (Cos φ).

**Description of choice:**

Motors having > 4 poles have a lower power factor which would restrict or prevent use of the AEO function for energy savings. This parameter allows the user to calibrate the AEO function to the power factor of the motor so that AEO can be used with motors of 6, 8, and 12 poles as well as 4 and 2 poles.



**NB!:**

The default value is 0.75 and should **NOT** be changed unless the specific motor has power factor lower than 0.75. This is typically the case for motors having more than 4 poles or low efficiency motors.

■ References and Limits 200-228

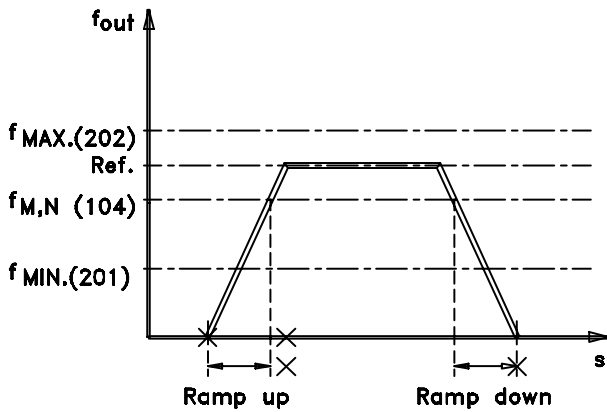

175HA334.10

In this parameter group, the frequency and reference range of the frequency converter are established.

This parameter group also includes:

- Setting of ramp times
- Choice of four preset references
- Possibility of programming four bypass frequencies.
- Setting of maximum current to motor.
- Setting of warning limits for current, frequency, reference and feedback.

**200 Output frequency range**

**(FREQUENCY RANGE)**

**Value:**

- ★0 - 120 Hz (0 - 120 HZ) [0]
- 0 - 1000 Hz (0 - 1000 HZ) [1]

**Function:**

This is where to select the maximum output frequency range to be set in parameter 202 *Output frequency high limit, f<sub>MAX</sub>*.

**Description of choice:**

Select the required output frequency range.

**201 Output frequency low limit, f<sub>MIN</sub>**

**(MIN. FREQUENCY)**

**Value:**

- 0.0 - f<sub>MAX</sub> ★ 0.0 HZ

**Function:**

This is where to select the minimum output frequency.

**Description of choice:**

A value from 0.0 Hz to the *Output frequency high limit, f<sub>MAX</sub>* frequency set in parameter 202 can be selected.

**202 Output frequency high limit, f<sub>MAX</sub>**

**(MAX. FREQUENCY)**

**Value:**

- f<sub>MIN</sub> - 120/1000 Hz
- (par. 200 *Output frequency range*) ★ 50 Hz

**Function:**

In this parameter, a maximum output frequency can be selected that corresponds to the highest speed at which the motor can be.



**NB!:**

The output frequency of the frequency converter can never assume a value higher than 1/10 of the switching frequency (parameter 407 *Switching frequency*).

**Description of choice:**

A value from f<sub>MIN</sub> to the choice made in parameter 200 *Output frequency range* can be selected.

★ = factory setting. () = display text [] = value for use in communication via serial communication port

### Reference handling

Reference handling is shown in the block diagram underneath.

The block diagram shows how a change in a parameter can affect the resulting reference.

Parameters 203 to 205 *Reference handling, minimum and maximum reference* and parameter 210 *Reference type* define the way reference handling can be carried out. The mentioned parameters are active both in a closed and in an open loop.

Remote references are defined as:

- External references, such as analog inputs 53, 54 and 60, pulse reference via terminal 17/29 and reference from serial communication.
- Preset references.

The resulting reference can be shown in the display by selecting *Reference [%]* in parameters 007-010 *Display readout* and in the form of a unit by selecting *Resulting reference [unit]*. See the section on *Feedback handling* in connection with a closed loop.

The sum of the external references can be shown in the display as a percentage of the range from *Minimum reference, Ref<sub>MIN</sub>* to *Maximum reference, Ref<sub>MAX</sub>*. Select *External reference, % [25]* in parameters 007-010 *Display readout* if a readout is required.

It is possible to have both preset references and external references at the same time. In parameter 210 *Reference type* a choice is made of how the preset references are to be added to the external references.

Furthermore, an independent local reference exists, where the resulting reference is set by means of the [+/-] keys. If local reference has been selected, the output frequency range is limited by parameter 201 *Output frequency low limit, f<sub>MIN</sub>* and parameter 202 *Output frequency high limit, f<sub>MAX</sub>*.



#### NB!:

If the local reference is active, the frequency converter will always be in *Open loop* [0], regardless of the choice made in parameter 100 *Configuration*.

The unit of the local reference can be set either as Hz or as a percentage of the output frequency range. The unit is selected in parameter 011 *Unit of local reference*.

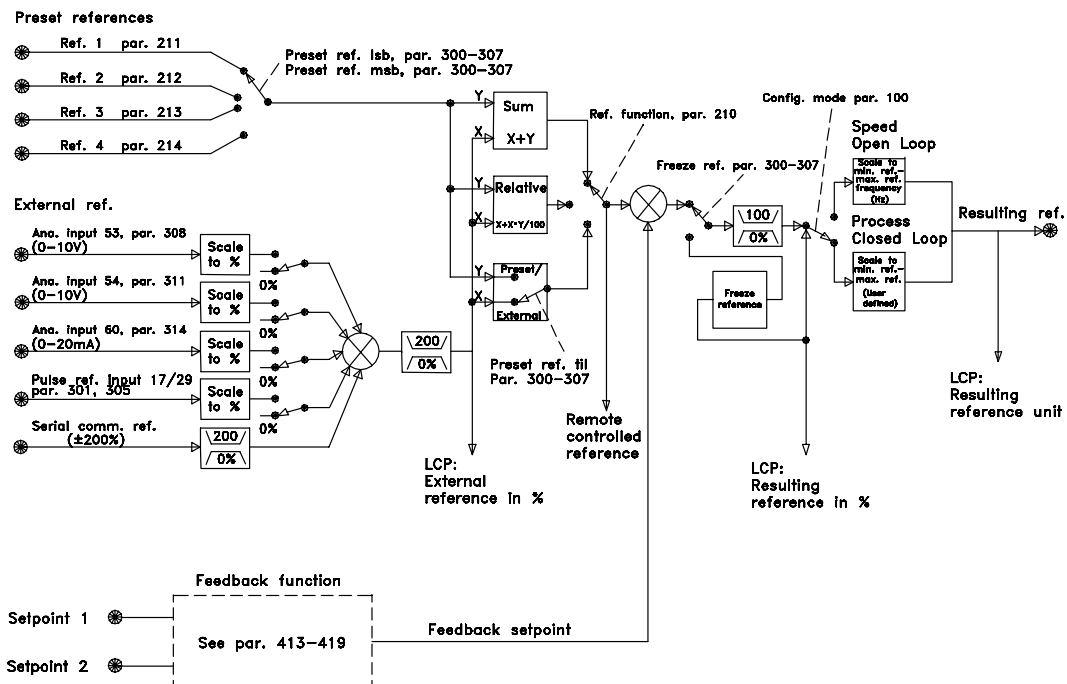

175HA375.14

★ = factory setting. () = display text [] = value for use in communication via serial communication port

### 203 Reference site

#### (REFERENCE SITE)

##### Value:

★Hand/Auto linked reference (LINKED TO HAND/AUTO)	[0]
Remote reference (REMOTE)	[1]
Local reference (LOCAL)	[2]

##### Function:

This parameter determines the location of the active reference. If *Hand/Auto linked reference* [0] is selected, the resulting reference will depend on whether the frequency converter is in Hand or Auto mode.

The table shows which references are active when *Hand/Auto linked reference* [0], *Remote reference* [1] or *Local reference* [2] has been selected. The Hand mode or Auto mode can be selected via the control keys or via a digital input, parameters 300-307 *Digital inputs*.

Reference handling	Hand mode	Auto mode
Hand/Auto [0]	Local ref. active	Remote ref. active
Remote [1]	Remote ref. active	Remote ref. active
Local [2]	Local ref. active	Local ref. active

##### Description of choice:

If *Hand/Auto linked reference* [0] is chosen, the motor speed in Hand mode will be decided by the local reference, while in Auto mode it depends on remote references and any setpoints selected.

If *Remote reference* [1] is selected, the motor speed will depend on remote references, regardless of whether Hand mode or Auto mode has been chosen.

If *Local reference* [2] is selected, the motor speed will only depend on the local reference set via the control panel, regardless of whether Hand mode or Auto mode has been selected.

### 204 Minimum reference, Ref<sub>MIN</sub>

#### (MIN. REFERENCE)

##### Value:

Parameter 100 *Configuration = Open loop* [0].  
0.000 - parameter 205 Ref<sub>MAX</sub> ★ 0.000 Hz  
Parameter 100 *Configuration = Closed loop* [1].  
-Par. 413 *Minimum feedback*  
- par. 205 Ref<sub>MAX</sub> ★ 0.000

##### Function:

The *Minimum reference* gives the minimum value that can be assumed by the sum of all references. If *Closed loop* has been selected in parameter 100 *Configuration*, the minimum reference is limited by parameter 413 *Minimum feedback*.

Minimum reference is ignored when the local reference is active (parameter 203 *Reference site*). The unit for the reference can be seen from the following table:

	Unit
Par. 100 <i>Configuration = Open loop</i>	Hz
Par. 100 <i>Configuration = Closed loop</i>	Par. 415

##### Description of choice:

Minimum reference is set if the motor is to run at a minimum speed, regardless of whether the resulting reference is 0.

### 205 Maximum reference, Ref<sub>MAX</sub>

#### (MAX. REFERENCE)

##### Value:

Parameter 100 *Configuration = Open loop* [0]  
Parameter 204 Ref<sub>MIN</sub> - 1000.000 Hz ★ 50.000 Hz  
Parameter 100 *Configuration = Closed loop* [1]  
Par. 204 Ref<sub>MIN</sub>  
- par. 414 *Maximum feedback* ★ 50.000 Hz

##### Function:

The *Maximum reference* gives the maximum value that can be assumed by the sum of all references. If *Closed loop* [1] has been selected in parameter 100 *Configuration*, the maximum reference cannot be set above parameter 414 *Maximum feedback*. The *Maximum reference* is ignored when the local reference is active (parameter 203 *Reference site*).

The reference unit can be determined on the basis of the following table:

	Unit
Par. 100 <i>Configuration = Open loop</i>	Hz
Par. 100 <i>Configuration = Closed loop</i>	Par. 415

##### Description of choice:

*Maximum reference* is set if the motor speed is not to exceed the set value, regardless of whether the resulting reference is higher than *Maximum reference*.

### 206 Ramp-up time

#### (RAMP UP TIME)

##### Value:

1 - 3600 sec. ★ Depends on the unit

##### Function:

The ramp-up time is the acceleration time from 0 Hz to the rated motor frequency f<sub>M,N</sub> (parameter

104 *Motor frequency,  $f_{M,N}$* ). It is assumed that the output current does not reach the current limit (set in parameter 215 *Current limit  $I_{LIM}$* ).

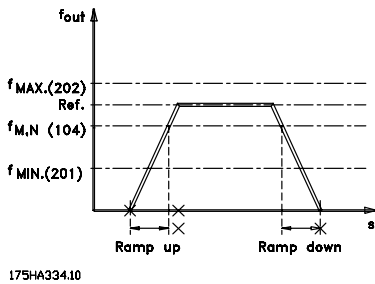

### Description of choice:

Program the desired ramp-up time.

### 207 Ramp-down time

#### (RAMP DOWN TIME)

#### Value:

1 - 3600 sec.      ☆ Depends on the unit

#### Function:

The ramp-down time is the deceleration time from the rated motor frequency  $f_{M,N}$  (parameter 104 *Motor frequency,  $f_{M,N}$* ) to 0 Hz, provided there is no overvoltage in the inverter because of the motor acting as a generator.

### Description of choice:

Program the desired ramp-down time.

### 208 Automatic ramp-down

#### (AUTO RAMPING)

#### Value:

Disable (DISABLE) [0]  
 ☆Enable (ENABLE) [1]

#### Function:

This function ensures that the frequency converter does not trip during deceleration if the ramp-down time set is too short. If, during deceleration, the frequency converter registers that the intermediate circuit voltage is higher than the max. value (see *list of warnings and alarms*), the frequency converter automatically extends the ramp-down time.



#### NB!:

If the function is chosen as *Enable* [1], the ramp time may be considerably extended in relation to the time set in parameter 207 *Ramp-down time*.

### Description of choice:

Program this function as *Enable* [1] if the frequency converter periodically trips during ramp-down. If a quick ramp-down time has been programmed that may lead to a trip under special conditions, the function can be set to *Enable* [1] to avoid trips.

### 209 Jog frequency

#### (JOG FREQUENCY)

#### Value:

Par. 201 *Output frequency Low limit* - par. 202  
*Output frequency high limit*      ☆ 10.0 HZ

#### Function:

The jog frequency  $f_{JOG}$  is the fixed output frequency at which the frequency converter is running when the jog function is activated.

Jog can be activated via the digital inputs.

### Description of choice:

Set the desired frequency.

■ Reference type

The example shows how the resulting reference is calculated when Preset references are used together with Sum and Relative in parameter 210 Reference type. See *Calculation of resulting reference*. See also the drawing in *Reference handling*.

The following parameters have been set:

Par. 204 <i>Minimum reference:</i>	10 Hz
Par. 205 <i>Maximum reference:</i>	50 Hz
Par. 211 <i>Preset reference:</i>	15%
Par. 308 <i>Terminal 53, analog input:</i>	Reference [1]
Par. 309 <i>Terminal 53, min. scaling:</i>	0 V
Par. 310 <i>Terminal 53, max. scaling:</i>	10 V

When parameter 210 *Reference type* is set to Sum [0], one of the adjusted *Preset references* (par. 211-214) will be added to the external references as a percentage of the reference range. If terminal 53 is energized by an analog input voltage of 4 V, the resulting reference will be as follows:

Par. 210 <i>Reference type</i> = Sum [0]	
Par. 204 <i>Minimum reference</i>	= 10.0 Hz
Reference contribution at 4 V	= 16.0 Hz
Par. 211 <u><i>Preset reference</i></u>	= 6.0 Hz
Resulting reference	= 32.0 Hz

If parameter 210 *Reference type* is set to *Relative* [1], one of the adjusted *Preset references* (par. 211-214) will be totaled as a percentage of the sum of the present external references. If terminal 53 is energized by an analog input voltage of 4 V, the resulting reference will be as follows:

Par. 210 <i>Reference type</i> = <i>Relative</i> [1]	
Par. 204 <i>Minimum reference</i>	= 10.0 Hz
Reference contribution at 4 V	= 16.0 Hz
Par. 211 <u><i>Preset reference</i></u>	= 2.4 Hz
Resulting reference	= 28.4 Hz

The graph in the next column shows the resulting reference in relation to the external reference varied from 0-10 V. Parameter 210 *Reference type* has been programmed for *Sum* [0] and *Relative* [1], respectively. In addition, a graph is shown in which parameter 211 *Preset reference* 1 is programmed for 0%.

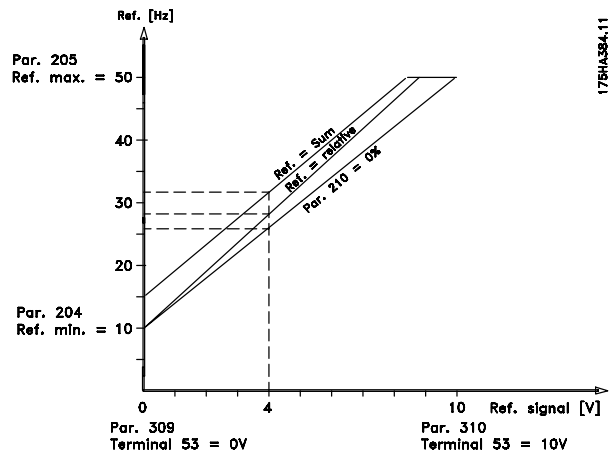

**210 Reference type**

**(REF. FUNCTION)**

**Value:**

★Sum (SUM)	[0]
Relative (RELATIVE)	[1]
External/preset (EXTERNAL/PRESET)	[2]

**Function:**

It is possible to define how the preset references are to be added to the other references. For this purpose, *Sum* or *Relative* is used. It is also possible - by using the *External/preset* function - to select whether a shift between external references and preset references is wanted. See *Reference handling*.

**Description of choice:**

If *Sum* [0] is selected, one of the adjusted preset references (parameters 211-214 *Preset reference*) is added to the other external references as a percentage of the reference range (Ref<sub>MIN</sub>-Ref<sub>MAX</sub>). If *Relative* [1] is selected, one of the adjusted preset references (parameters 211-214 *Preset reference*) is totaled as a percentage of the sum of the present external references. If *External/preset* [2] is selected, it is possible to shift between external references and preset references via terminal 16, 17, 29, 32 or 33 (parameter 300, 301, 305, 306 or 307 *Digital inputs*). Preset references will be a percentage value of the reference range. External reference is the sum of the analog references, pulse references and any references from serial communication.

★ = factory setting. () = display text [] = value for use in communication via serial communication port





### NB!:

If *Sum* or *Relative* is selected, one of the preset references will always be active. If the preset references are to be without influence, they should be set to 0% (as in the factory setting) via the serial communication port.

### 211 Preset reference 1 (PRESET REF. 1)

### 212 Preset reference 2 (PRESET REF. 2)

### 213 Preset reference 3 (PRESET REF. 3)

### 214 Preset reference 4 (PRESET REF. 4)

#### Value:

-100.00 % - +100.00 %      ★ 0.00%  
of the reference range/external reference

#### Function:

Four different preset references can be programmed in parameters 211-214 *Preset reference*. The preset reference is stated as a percentage value of the reference range (Ref<sub>MIN</sub> - Ref<sub>MAX</sub>) or as a percentage of the other external references, depending on the choice made in parameter 210 *Reference type*. The choice between the preset references can be made by activating terminal 16, 17, 29, 32 or 33, cf. the table below.

Terminal 17/29/33 preset ref. msb	Terminal 16/29/32 preset ref. lsb	
0	0	Preset ref. 1
0	1	Preset ref. 2
1	0	Preset ref. 3
1	1	Preset ref. 4

#### Description of choice:

Set the required preset reference(s) that is/are to be the options.

### 215 Current limit, I<sub>LIM</sub> (CURRENT LIMIT)

#### Value:

0.1 - 1.1 x I<sub>VLT,N</sub>      ★ 1.1 x I<sub>VLT,N</sub> [A]

#### Function:

This is where the maximum output current I<sub>LIM</sub> is set. The factory setting corresponds to the rated output current. Current limit is for protection of the frequency converter. If the current limit is set within the range of

★ = factory setting. () = display text [] = value for use in communication via serial communication port

1.0-1.1 x I<sub>VLT,N</sub> (the rated output current of the frequency converter), the frequency converter can only handle a load intermittently, i.e. for short periods at a time. After the load has been higher than I<sub>VLT,N</sub>, it must be ensured that for a period the load is lower than I<sub>VLT,N</sub>. Please note that if the current limit is set to less than I<sub>VLT,N</sub>, the acceleration torque will be reduced accordingly. If the drive is in current limit and a stop command is initiated with the stop button on the LCP key pad, the drive output is immediately turned off and the motor will coast to a stop.



### NB!:

Current limit should not be used for motor protection; parameter 117 is for motor protection.

#### Description of choice:

Set the required maximum output current I<sub>LIM</sub>.

### 216 Frequency bypass, bandwidth (FREQUENCY BYPASS B.W.)

#### Value:

0 (OFF) - 100 Hz      ★ Disable

#### Function:

Some systems call for some output frequencies to be avoided because of mechanical resonance problems. The frequencies to avoid can be programmed in parameters 217-220 *Frequency bypass*. In this parameter (216 *Frequency bypass, bandwidth*), a definition can be given of a bandwidth around each of these frequencies.

#### Description of choice:

The bypass bandwidth is equal to the programmed bandwidth frequency. This bandwidth will be centered around each bypass frequency.

**217 Frequency bypass 1**

(BYPASS FREQ. 1)

**218 Frequency bypass 2**

(BYPASS FREQ. 2)

**219 Frequency bypass 3**

(BYPASS FREQ. 3)

**220 Frequency bypass 4**

(BYPASS FREQ. 4)

**Value:**

0 - 120/1000 HZ ★ 120.0 Hz

The frequency range depends on the selection made in parameter 200 *Output frequency range*.

**Function:**

Some systems call for some output frequencies to be avoided because of mechanical resonance problems in the system.

**Description of choice:**

Enter the frequencies to be avoided.

**221 Warning: Low current, I<sub>LOW</sub>**

(WARN. LOW CURR.)

**Value:**

0.0 - par. 222 *Warning: High current I<sub>HIGH</sub>*, ★ 0.0A

**Function:**

When the motor current is below the limit, I<sub>LOW</sub>, programmed in this parameter, the display shows a flashing CURRENT LOW, provided *Warning* [1] has been selected in parameter 409 *Function in case of no load*. The frequency converter will trip if parameter 409 *Function in case of no load* has been selected as *Trip* [0]. The warning functions in parameters 221-228 are not active during ramp-up after a start command, ramp-down after a stop command or while stopped. The warning functions are activated when the output frequency has reached the resulting reference. The signal outputs can be programmed to generate a warning signal via terminal 42 or 45 and via the relay outputs.

**Description of choice:**

The lower signal limit I<sub>LOW</sub> must be programmed within the normal working range of the frequency converter.

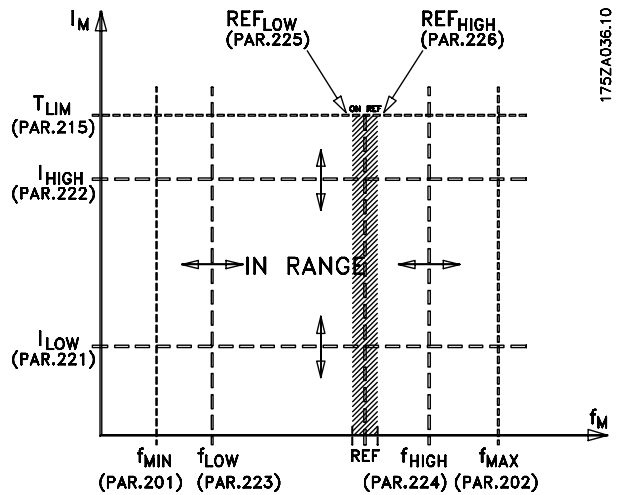

**222 Warning: High current, I<sub>HIGH</sub>**

(WARN. HIGH CURR.)

**Value:**

Parameter 221 - I<sub>VLT,MAX</sub> ★ I<sub>VLT,MAX</sub>

**Function:**

If the motor current is above the limit, I<sub>HIGH</sub>, programmed in this parameter, the display shows a flashing CURRENT HIGH. The warning functions in parameters 221-228 are not active during ramp-up after a start command, ramp-down after a stop command or while stopped. The warning functions are activated when the output frequency has reached the resulting reference. The signal outputs can be programmed to generate a warning signal via terminal 42 or 45 and via the relay outputs.

**Description of choice:**

The upper signal limit of the motor frequency, f<sub>HIGH</sub>, must be programmed within the normal working range of the frequency converter. See drawing at parameter 221 *Warning: Low current, I<sub>LOW</sub>*.

**223 Warning: Low frequency, f<sub>LOW</sub>**

(WARN. LOW FREQ.)

**Value:**

0.0 - parameter 224 ★ 0.0 Hz

**Function:**

If the output frequency is below the limit, f<sub>LOW</sub>, programmed in this parameter, the display will show a flashing FREQUENCY LOW. The warning functions in parameters 221-228 are not active during ramp-up after a start command, ramp-down after a stop command or while stopped.

★ = factory setting. () = display text [] = value for use in communication via serial communication port

The warning functions are activated when the output frequency has reached the selected reference. The signal outputs can be programmed to generate a warning signal via terminal 42 or 45 and via the relay outputs.

### Description of choice:

The lower signal limit of the motor frequency,  $f_{LOW}$ , must be programmed within the normal working range of the frequency converter. See drawing at parameter 221 *Warning: Low current,  $I_{LOW}$ .*

### 224 Warning: High frequency , $f_{HIGH}$ (WARN. HIGH FREQ.)

#### Value:

Par. 200 *Output frequency range* = 0-120 Hz [0].  
parameter 223 - 120 Hz                      ★ 120.0 Hz  
Par. 200 *Output frequency range* = 0-1000 Hz [1].  
parameter 223 - 1000 Hz                      ★ 120.0 Hz

#### Function:

If the output frequency is above the limit,  $f_{HIGH}$ , programmed in this parameter, the display will show a flashing FREQUENCY HIGH. The warning functions in parameters 221-228 are not active during ramp-up after a start command, ramp-down after a stop command or while stopped. The warning functions are activated when the output frequency has reached the resulting reference. The signal outputs can be programmed to generate a warning signal via terminal 42 or 45 and via the relay outputs.

### Description of choice:

The higher signal limit of the motor frequency,  $f_{HIGH}$ , must be programmed within the normal working range of the frequency converter. See drawing at parameter 221 *Warning: Low current,  $I_{LOW}$ .*

### 225 Warning: Low reference, $REF_{LOW}$ (WARN. LOW REF.)

#### Value:

-999,999.999 -  $REF_{HIGH}$  (par.226)   ★ -999,999.999

#### Function:

When the remote reference lies under the limit,  $REF_{LOW}$ , programmed in this parameter, the display shows a flashing REFERENCE LOW.

The warning functions in parameters 221-228 are not active during ramp-up after a start command, ramp-down after a stop command or while

★ = factory setting. () = display text [] = value for use in communication via serial communication port

stopped. The warning functions are activated when the output frequency has reached the selected reference. The signal outputs can be programmed to generate a warning signal via terminal 42 or 45 and via the relay outputs.

The reference limits in parameter 226 *Warning: High reference,  $Ref_{HIGH}$* , and in parameter 225 *Warning: Low reference,  $Ref_{LOW}$* , are only active when remote reference has been selected. In *Open loop mode* the unit for the reference is Hz, while in *Closed loop mode* the unit is programmed in parameter 415 *Process units*.

### Description of choice:

The lower signal limit,  $REF_{LOW}$ , of the reference must be programmed within the normal working range of the frequency converter, provided parameter 100 *Configuration* has been programmed for *Open loop* [0]. In *Closed loop* [1] (parameter 100),  $REF_{LOW}$  must be within the reference range programmed in parameters 204 and 205.

### 226 Warning: High reference , $REF_{HIGH}$ (WARN. HIGH REF.)

#### Value:

$REF_{LOW}$  (par. 225) - 999,999.999   ★ 999,999.999

#### Function:

If the resulting reference is above the limit,  $REF_{HIGH}$ , programmed in this parameter, the display shows a flashing REFERENCE HIGH. The warning functions in parameters 221-228 are not active during ramp-up after a start command, ramp-down after a stop command or while stopped. The warning functions are activated when the output frequency has reached the resulting reference. The signal outputs can be programmed to generate a warning signal via terminal 42 or 45 and via the relay outputs.

The reference limits in parameter 226 *Warning: High reference,  $Ref_{HIGH}$* , and in parameter 227 *Warning: Low reference,  $Ref_{LOW}$* , are only active when remote reference has been selected.

In *Open loop* the unit for the reference is Hz, while in *Closed loop* the unit is programmed in parameter 415 *Process units*.

### Description of choice:

The upper signal limit,  $REF_{HIGH}$ , of the reference must be programmed within the normal working range of the frequency converter, provided parameter 100 *Configuration* has been programmed for *Open loop*

[0]. In *Closed loop* [1] (parameter 100), Ref<sub>HIGH</sub> must be within the reference range programmed in parameters 204 and 205.

**Description of choice:**

Set the required value within the feedback range (parameter 413 *Minimum feedback*, FB<sub>MIN</sub>, and 414 *Maximum feedback*, FB<sub>MAX</sub>).

**227 Warning: Low feedback, FB<sub>LOW</sub>**

**(WARN LOW FDBK)**

**Value:**

-999,999.999 - FB<sub>HIGH</sub>  
(parameter 228)                      ★ -999.999,999

**Function:**

If the feedback signal is below the limit, FB<sub>LOW</sub>, programmed in this parameter, the display will show a flashing FEEDBACK LOW.  
The warning functions in parameters 221-228 are not active during ramp-up after a start command, ramp-down after a stop command or while stopped. The warning functions are activated when the output frequency has reached the selected reference. The signal outputs can be programmed to generate a warning signal via terminal 42 or 45 and via the relay outputs.  
In *Closed loop*, the unit for the feedback is programmed in parameter 415 *Process units*.

**Description of choice:**

Set the required value within the feedback range (parameter 413 *Minimum feedback*, FB<sub>MIN</sub>, and 414 *Maximum feedback*, FB<sub>MAX</sub> ).

**228 Warning: High feedback, FB<sub>HIGH</sub>**

**(WARN. HIGH FDBK)**

**Value:**

FB<sub>LOW</sub>  
(parameter 227) - 999,999.999      ★ 999.999,999

**Function:**

If the feedback signal is above the limit, FB<sub>HIGH</sub>, programmed in this parameter, the display will show a flashing FEEDBACK HIGH.  
The warning functions in parameters 221-228 are not active during ramp-up after a start command, ramp-down after a stop command or while stopped. The warning functions are activated when the output frequency has reached the selected reference. The signal outputs can be programmed to generate a warning signal via terminal 42 or 45 and via the relay outputs.  
In *Closed loop*, the unit for the feedback is programmed in parameter 415 *Process units*.

★ = factory setting. () = display text [] = value for use in communication via serial communication port

### Inputs and outputs 300-365

In this parameter group, the functions that relate to the input and output terminals of the frequency converter are defined.

The digital inputs (terminals 16, 17, 18, 19, 27, 29, 32 and 33) are programmed in parameters 300-307.

The table below gives the options for programming the inputs. The digital inputs require a signal of 0 or 24 V DC. A signal lower than 5 V DC is a logic '0', while a signal higher than 10 V DC is a logic '1'.

The terminals for the digital inputs can be connected to the internal 24 V DC supply, or an external 24 V DC supply can be connected.

The drawings in the next column show one Setup using the internal 24 V DC supply and one Setup using an external 24 V DC supply.

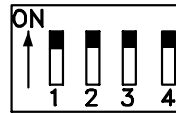
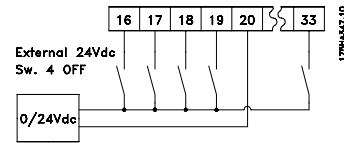
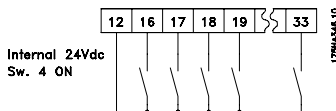

175ZA068.11 Switch 4, which is located on the Dip switch control card, is used for separating the common potential of the internal 24 V DC supply from

the common potential of the external 24 V DC supply.

See *Electrical installation*.

Please note that when Switch 4 is in the OFF position, the external 24 V DC supply is galvanically isolated from the frequency converter.

Digital inputs	Terminal no.	16	17	18	19	27	29	32	33
Value:	parameter	300	301	302	303	304	305	306	307
No function	(NO OPERATION)	[0]	[0]	[0]	[0]		[0]	[0]★	[0]★
Reset	(RESET)	[1]★	[1]				[1]	[1]	[1]
Coasting stop, inverse	(COAST INVERSE)						[0]★		
Reset and coasting stop, inverse	(COAST & RESET INVERS)					[1]			
Start	(START)			[1]★					
Reversing	(REVERSE)				[1]★				
Reversing and start	(START REVERSE)				[2]				
DC-braking, inverse	(DC BRAKE INVERSE)				[3]	[2]			
Safety Interlock	(SAFETY INTERLOCK)					[3]			
Freeze Reference	(FREEZE REFERENCE)	[2]	[2]★				[2]	[2]	[2]
Freeze output	(FREEZE OUTPUT)	[3]	[3]				[3]	[3]	[3]
Selection of Setup, lsb	(SETUP SELECT LSB)	[4]					[4]	[4]	
Selection of Setup, msb	(SETUP SELECT MSB)		[4]				[5]		[4]
Preset reference, on	(PRESET REF. ON)	[5]	[5]				[6]	[5]	[5]
Preset reference, lsb	(PRESET REF. SEL. LSB)	[6]					[7]	[6]	
Preset reference, msb	(PRESET REF. MSB)		[6]				[8]		[6]
Speed down	(SPEED DOWN)		[7]				[9]		[7]
Speed up	(SPEED UP)	[7]					[10]	[7]	
Run permissive	(RUN PERMISSIVE)	[8]	[8]				[11]	[8]	[8]
Jog	(JOG)	[9]	[9]				[12]★	[9]	[9]
Data change lock	(PROGRAMMING LOCK)	[10]	[10]				[13]	[10]	[10]
Pulse reference	(PULSE REFERENCE)		[11]				[14]		
Pulse feedback	(PULSE FEEDBACK)								[11]
Hand start	(HAND START)	[11]	[12]				[15]	[11]	[12]
Auto start	(AUTOSTART)	[12]	[13]				[16]	[12]	[13]
Fire mode	(FIRE MODE)	[13]	[14]						
Fire mode inverse	(FIRE MODE INVERSE)	[14]	[15]						
Enable RTC	(ENABLE RTC)	[25]	[25]						

★ = factory setting. () = display text [] = value for use in communication via serial communication port

### Function:

In parameters 300-307 *Digital inputs* it is possible to choose between the different possible functions related to the digital inputs (terminals 16-33). The functional options are given in the table on the previous page.

### Description of choice:

**No function** is selected if the frequency converter is not to react to signals transmitted to the terminal.

**Reset** the frequency converter after an alarm; however, trip locked alarms cannot be reset by cycling mains power supply. See table in *List of warnings and alarms*. Reset will occur on the rising edge of the signal.

**Coasting stop**, inverse is used to force the frequency converter to "release" the motor immediately (the output transistors are "turned off") to make it coast freely to stop. Logic '0' implements coasting to stop.

**Reset and coasting stop, inverse** is used for activating coasting stop at the same time as reset. Logic '0' implements coasting stop and reset. Reset will be activate on the falling edge of the signal.

**DC braking, inverse** is used for stopping the motor by energizing it with a DC voltage for a given time, see parameters 114-116 *DC brake*. Please note that this function is only active if the value of parameters 114 *DC brake current* and 115 *DC braking time* is different from 0. Logic '0' implements DC braking. See *DC braking*.

**Safety interlock** has the same function as *Coasting stop, inverse*, but *Safety interlock* generates the alarm message 'external fault' on the display when terminal 27 is logic '0'. The alarm message will also be active via digital outputs 42/45 and relay outputs 1/2, if programmed for *Safety interlock*. The alarm can be reset using a digital input or the [OFF/STOP] key.

**Start** is selected if a start/stop command is required. Logic '1' = start, logic '0' = stop.



### NB!:

Please note, that if the frequency converter is in current limit the stop function will not be active.

**Reversing** is used for changing the direction of rotation of the motor shaft. Logic '0' will not implement reversing. Logic '1' will implement reversing. The reversing signal only changes the direction of rotation; it does not activate the start function. Is not active together with *Closed loop*.

**Reversing and start** is used for start/stop and reversing using the same signal. A start signal via

★ = factory setting. () = display text [] = value for use in communication via serial communication port

terminal 18 at the same time is not allowed. Is not active together with *Closed loop*.

**Freeze reference** freezes the present reference. The frozen reference can now only be changed by means of *Speed up* or *Speed down*. The frozen reference is saved after a stop command and in case of mains failure.

**Freeze output** freezes the present output frequency (in Hz). The frozen output frequency can now only be changed by means of *Speed up* or *Speed down*.



### NB!:

If *Freeze output* is active, the frequency converter cannot be stopped via terminal 18. The frequency converter can only be stopped when terminal 27 or terminal 19 has been programmed for *DC braking, inverse*.

**Selection of Setup, Isb** and **Selection of Setup, msb** enables a choice of one of the four Setups. However, this presupposes that parameter 002 *Active Setup* has been set at *Multi Setup* [5].

	Setup, msb	Setup, Isb
Setup 1	0	0
Setup 2	0	1
Setup 3	1	0
Setup 4	1	1

**Preset reference, on** is used for switching between remote reference and preset reference. This assumes that *Remote/preset* [2] has been selected in parameter 210 *Reference type*. Logic '0' = remote references active; logic '1' = one of the four preset references is active in accordance with the table below.

**Preset reference, Isb** and **Preset reference,msb** enables a choice of one of the four preset references, in accordance with the table below.

	Preset ref. msb	Preset ref. Isb
Preset ref. 1	0	0
Preset ref. 2	0	1
Preset ref. 3	1	0
Preset ref. 4	1	1

**Speed up and speed down** are selected if digital control of the up/down speed is desired. This function is only active if *Freeze reference* or *Freeze output* has been selected.

As long as there is a logic '1' on the terminal selected for *Speed up*, the reference or the output frequency will increase by the *Ramp-up time* set in parameter 206.

As long as there is a logic '1' on the terminal selected for Speed down, the reference or the output frequency will increase by the *Ramp-down time* set in parameter 207. Pulses (logic '1' minimum high for 3 ms and a minimum pause of 3 ms) will lead to a change of speed of 0.1% (reference) or 0.1 Hz (output frequency).

Example:

	Terminal (16)	Terminal (17)	Freeze ref./ Freeze output
No speed change	0	0	1
Speed down	0	1	1
Speed up	1	0	1
Speed down	1	1	1

The speed reference frozen via the control panel can be changed even if the frequency converter has stopped. In addition, the frozen reference will be remembered in case of a mains failure.

**Run permissive.** There must be an active start signal via the terminal, where *Run permissive* has been programmed, before a start command can be accepted. *Run permissive* has a logic 'AND' function related to Start (terminal 18, parameter 302 *Terminal 18, Digital input*), which means that in order to start the motor, both conditions must be fulfilled. If *Run permissive* is programmed on several terminals, *Run permissive* must only be logic '1' on one of the terminals for the function to be carried out. See *Example of application - Speed control of fan in ventilation system*.

**Jog** is used to override the output frequency to the frequency set in parameter 209 *Jog frequency* and issue a start command. If local reference is active, the frequency converter will always be in *Open loop* [0], regardless of the selection made in parameter 100 *Configuration*.

Jog is not active if a stop command has been given via terminal 27.

**Data change lock** is selected if data changes to parameters are not to be made via the control unit; however, it will still be possible to carry out data changes via the bus.

**Pulse reference** is selected if a pulse sequence (frequency) is selected as a reference signal.

0 Hz corresponds to  $Ref_{MIN}$ , parameter 204 *Minimum reference, Ref<sub>MIN</sub>*.

The frequency set in parameter 327 *Pulse reference, max. frequency* corresponds to parameter 205 *Maximum reference, Ref<sub>MAX</sub>*.

**Pulse feedback** is selected if a pulse sequence (frequency) is selected as a feedback signal. Parameter 328 *Pulse feedback, max. frequency* is where the maximum frequency for pulse feedback is set.

**Hand start** is selected if the frequency converter is to be controlled by means of an external hand/off or H-O-A switch. A logic '1' (Hand start active) will mean that the frequency converter starts the motor. A logic '0' means that the connected motor stops. The frequency converter will then be in OFF/STOP mode, unless there is an active *Auto start signal*. See also the description in *Local control*.



**NB!:**

An active *Hand* and *Auto* signal via the digital inputs will have higher priority than the [HAND START]-[AUTO START] control keys.

**Auto start** is selected if the frequency converter is to be controlled via an external auto/off or H-O-A switch. A logic '1' will place the frequency converter in auto mode allowing a start signal on the control terminals or the serial communication port. If *Auto start* and *Hand start* are active at the same time on the control terminals, *Auto start* will have the highest priority. If *Auto start* and *Hand start* are not active, the connected motor will stop and the frequency converter will then be in OFF/STOP mode.

**Fire Mode** is selected if the Fire Mode function is to be activated via a logical '1' on terminal 16 or 17. This enables the frequency converter to run without trip lock in case of alarms or warnings. If an alarm causes a trip an automatic reset is activated. Please note Fire Mode must be enabled in parameter 430 for terminal 16 or 17 to activate the Fire Mode. The frequency converter will run at the in parameter 431 selected speed. Only by setting input 16 or 17 low or opening terminal 27 deactivates fire mode again.

**Fire Mode inverse** is selected if the Fire Mode function is to be activated via a logical '0' on terminal 16 or 17. This enables the frequency converter to run without trip lock in case of alarms or warnings. If an alarm causes a trip an automatic reset is

★ = factory setting. () = display text [] = value for use in communication via serial communication port

activated. Please note Fire Mode must be enabled in parameter 430 for terminal 16 or 17 to activate the Fire Mode. The frequency converter will run at the in parameter 431 selected speed.

Only by setting input 16 or 17 high or opening terminal 27 deactivates fire mode again.

**Enable RTC** is used to start the real time clock function. When enabled the real time clock functions will be executed based on time. See description of RTC for further information.

---



### ■ Analogue inputs

Two analogue inputs for voltage signals (terminals 53 and 54) are provided for reference and feedback signals. Furthermore, an analogue input is available for current signal (terminal 60). A thermistor can be connected to voltage input 53 or 54.

The two analogue voltage inputs can be scaled in the range of 0-10 V DC; the current input in the range of 0-20 mA.

The table below gives the possibilities for programming the analogue inputs. Parameter 317 *Time out* and 318 *Function after time out* allow activation of a time-out function on all analogue inputs. If the signal value of the reference or feedback signal connected to one of the analogue input terminals drops to below 50% of the minimum scaling, a function will be activated after the time out determined in parameter 318, *Function after time out*.

Analogue inputs	terminal no.	53(voltage)	54(voltage)	60(current)
Value:	parameter	308	311	314
No operation	(NO OPERATION)	[0]	[0]★	[0]
Reference	(REFERENCE)	[1]★	[1]	[1]★
Feedback	(FEEDBACK)	[2]	[2]	[2]
Thermistor	(THERMISTOR)	[3]	[3]	

### 308 Terminal 53, analogue input voltage

#### (AI [V] 53 FUNCT.)

#### Function:

This parameter is used to select the required function to be linked to terminal 53.

#### Description of choice:

**No operation.** Is selected if the frequency converter is not to react to signals connected to the terminal.

**Reference.** Is selected to enable change of reference by means of an analogue reference signal. If reference signals are connected to several inputs, these reference signals must be added up.

**Feedback.** If a feedback signal is connected, there is a choice of a voltage input (terminal 53 or 54) or a current input (terminal 60) as feedback. In the case of zone regulation, feedback signals must be selected as voltage inputs (terminals 53 and 54). See *Feedback handling*.

**Thermistor.** Is selected if a motor-integrated thermistor (according to DIN 44080/81) should stop the frequency converter in case of motor overtemperature. The cut-out value is 3 kohm. If a motor features a Klaxon thermal switch instead, this can also be connected to the input. If motors run in parallel, the thermistors/thermal switches can be connected in series (total resistance < 3 kohm). Parameter 117 *Motor thermal protection* must be programmed for *Thermal warning* [1] or *Thermistor trip* [2], and the thermistor must be inserted between terminal 53 or 54 (analogue voltage input) and terminal 50 (+10 V supply).

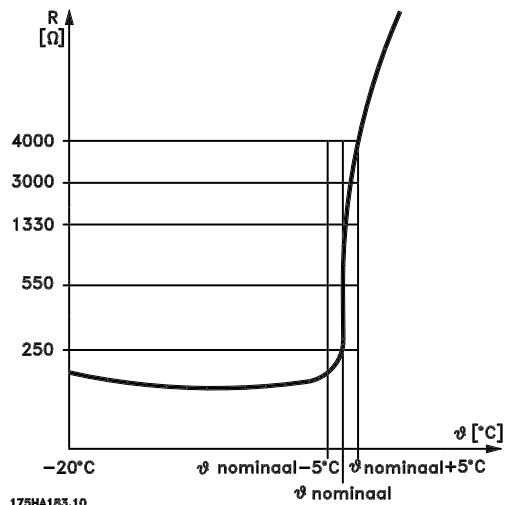

★ = factory setting. () = display text [] = value for use in communication via serial communication port

**309 Terminal 53, min. scaling**
**(AI 53 SCALE LOW)**
**Value:**

 0.0 - 10.0 V ★ 0.0 V
**Function:**

This parameter is used for setting the signal value that has to correspond to the minimum reference or the minimum feedback, parameter 204 *Minimum reference*,  $Ref_{MIN}$ /413 *Minimum feedback*,  $FB_{MIN}$ . See *Reference handling* or *Feedback handling*.

**Description of choice:**

Set the required voltage value.  
 For reasons of accuracy, voltage losses in long signal lines can be compensated for.  
 If the time-out function is to be applied (parameters 317 *Time out* and 318 *Function after time out*), the value must be set to > 1 V.

**310 Terminal 53, max. scaling**
**(AI 53 SCALE HIGH)**
**Value:**

 0.0 - 10.0 V ★ 10.0 V
**Function:**

This parameter is used for setting the signal value that has to correspond to the maximum reference value or the maximum feedback, parameter 205 *Maximum reference*,  $Ref_{MAX}$ /414 *Maximum feedback*,  $FB_{MAX}$ . See *Reference handling* or *Feedback handling*.

**Description of choice:**

Set the required voltage value.  
 For reasons of accuracy, voltage losses in long signal lines can be compensated for.

**311 Terminal 54, analog input voltage**
**(AI [V] 54 FUNCT.)**
**Value:**

 See description of parameter 308. ★ No operation
**Function:**

This parameter chooses between the different functions available for the input, terminal 54.  
 Scaling of the input signal is done in parameter 312 *Terminal 54, min. scaling* and in parameter 313 *Terminal 54, max. scaling*.

**Description of choice:**

See description of parameter 308.

For reasons of accuracy, voltage losses in long signal lines should be compensated for.

**312 Terminal 54, min. scaling**
**(AI 54 SCALE LOW)**
**Value:**

 0.0 - 10.0 V ★ 0.0 V
**Function:**

This parameter is used for setting the signal value that corresponds to the minimum reference value or the minimum feedback, parameter 204 *Minimum reference*,  $Ref_{MIN}$  /413 *Minimum feedback*,  $FB_{MIN}$ . See *Reference handling* or *Feedback handling*.

**Description of choice:**

Set the required voltage value.  
 For reasons of accuracy, voltage losses in long signal lines can be compensated for.  
 If the time-out function is to be applied (parameters 317 *Time out* and 318 *Function after time out*), the value must be set to > 1 V.

**313 Terminal 54, max. scaling**
**(AI 54 SCALE HIGH)**
**Value:**

 0.0 - 10.0 V ★ 10.0 V
**Function:**

This parameter is used for setting the signal value that corresponds to the maximum reference value or the maximum feedback, parameter 205 *Maximum reference*,  $Ref_{MAX}$ /414 *Maximum feedback*,  $FB_{MAX}$ . See *Reference handling* or *Feedback handling*.

**Description of choice:**

Set the required voltage value.  
 For reasons of accuracy, voltage losses in long signal lines can be compensated for.

**314 Terminal 60, analogue input current**
**(AI [MA] 60 FUNCT.)**
**Value:**

 See description of parameter 308. ★ Reference
**Function:**

This parameter allows a choice between the different functions available for the input, terminal 60.

Scaling of the input signal is effected in parameter 315 *Terminal 60, min. scaling* and in parameter 316 *Terminal 60, max. scaling*.

### Description of choice:

See description of parameter 308 *Terminal 53, analogue input voltage*.

### 315 Terminal 60, min. scaling

#### (AI 60 SCALE LOW)

#### Value:

0.0 - 20.0 mA ★ 4.0 mA

#### Function:

This parameter determines the signal value that corresponds to the minimum reference or the minimum feedback, parameter 204 *Minimum reference*,  $Ref_{MIN}/413$  *Minimum feedback*,  $FB_{MIN}$ . See *Reference handling* or *Feedback handling*.

### Description of choice:

Set the required current value.  
The time-out function is to be used (parameters 317 *Time out* and 318 *Function after time out*), the value must be set to > 2 mA.

### 316 Terminal 60, max. scaling

#### (AI 60 SCALE HIGH)

#### Value:

0.0 - 20.0 mA ★ 20.0 mA

#### Function:

This parameter determines the signal value that corresponds to the maximum reference value, parameter 205 *Maximum reference value*,  $Ref_{MAX}$ . See *Reference handling* or *Feedback handling*.

### Description of choice:

Set the desired current value.

### 317 Time out

#### (LIVE ZERO TIME)

#### Value:

1 - 99 sec. ★ 10 sec.

#### Function:

If the signal value of the reference or feedback signal connected to one of the input terminals 53, 54 or 60 drops to below 50% of the minimum scaling during a period longer than the preset time,

the function selected in parameter 318 *Function after time out* will be activated.

This function will only be active if, in parameter 309 or 312, a value has been selected for *terminals 53 and 54, min. scaling* that exceeds 1 V, or if, in parameter 315 *Terminal 60, min. scaling*, a value has been selected that exceeds 2 mA.

### Description of choice:

Set the desired time.

### 318 Function after time out

#### (LIVE ZERO FUNCT.)

#### Value:

★Off (NO FUNCTION)	[0]
Freeze output frequency (FREEZE OUTPUT FREQ.)	[1]
Stop (STOP)	[2]
Jog (JOG FREQUENCY)	[3]
Max. output frequency (MAX FREQUENCY)	[4]
Stop and trip (STOP AND TRIP)	[5]

#### Function:

This is where to select the function to be activated after the end of the time-out period (parameter 317 *Time out*).

If a time-out function occurs at the same time as a bus time-out function (parameter 556 *Bus time interval function*), the time-out function in parameter 318 will be activated.

### Description of choice:

The output frequency of the frequency converter can be:

- frozen at the present value [1]
- overruled to stop [2]
- overruled to jog frequency [3]
- overruled to max. output frequency [4]
- overruled to stop with subsequent trip [5].

★ = factory setting. () = display text [] = value for use in communication via serial communication port

**■ Analog/digital outputs**

The two analog/digital outputs (terminals 42 and 45) can be programmed to show the present status or a process value such as 0 -  $f_{MAX}$ . If the frequency converter is used as a digital output, it gives the present status by means of 0 or 24 V DC.

If the analog output is used for giving a process value, there is a choice of three types of output signal:

0-20 mA, 4-20 mA or 0-32000 pulses (depending on the value set in parameter 322 *Terminal 45, output, pulse scaling*).

If the output is used as a voltage output (0-10 V), a pull-down resistor of 500  $\Omega$  should be fitted to terminal 39 (common for analog/digital outputs). If the output is used as a current output, the resulting impedance of the connected equipment should not exceed 500  $\Omega$ .

Analog/digital outputs	terminal no.	42	45
	parameter	319	321
No function (NO FUNCTION)		[0]	[0]
Drive ready (UN. READY)		[1]	[1]
Standby (STAND BY)		[2]	[2]
Running (RUNNING)		[3]	[3]
Running at ref. value (RUNNING AT REFERENCE)		[4]	[4]
Running, no warning (RUNNING NO WARNING)		[5]	[5]
Local reference active (DRIVE IN LOCAL REF.)		[6]	[6]
Remote references active (DRIVE IN REMOTE REF.)		[7]	[7]
Alarm (ALARM)		[8]	[8]
Alarm or warning (ALARM OR WARNING)		[9]	[9]
No alarm (NO ALARM)		[10]	[10]
Current limit (CURRENT LIMIT)		[11]	[11]
Safety interlock (SAFETY INTERLOCK)		[12]	[12]
Start command active (START SIGNAL APPLIED)		[13]	[13]
Reversing (RUNNING IN REVERSE)		[14]	[14]
Thermal warning (THERMAL WARNING)		[15]	[15]
Hand mode active (DRIVE IN HAND MODE)		[16]	[16]
Auto mode active (DRIVE IN AUTO MODE)		[17]	[17]
Sleep mode (SLEEP MODE)		[18]	[18]
Output frequency lower than $f_{LOW}$ parameter 223 (F OUT < F LOW)		[19]	[19]
Output frequency higher than $f_{HIGH}$ parameter 223 (F OUT > F HIGH)		[20]	[20]
Out of frequency range (FREQ. RANGE WARN.)		[21]	[21]
Output current lower than $I_{LOW}$ parameter 221 (I OUT < I LOW)		[22]	[22]
Output current higher than $I_{HIGH}$ parameter 222 (I OUT > I HIGH)		[23]	[23]
Out of current range (CURRENT RANGE WARN.)		[24]	[24]
Out of feedback range (FEEDBACK RANGE WARN.)		[25]	[25]
Out of reference range (REFERENCE RANGE WARN.)		[26]	[26]
Relay 123 (RELAY 123)		[27]	[27]
Mains imbalance (MAINS IMBALANCE)		[28]	[28]
Output frequency, 0 - $f_{MAX}$ 0-20 mA (OUT. FREQ. 0-20 mA)		[29]	[29]★
Output frequency, 0 - $f_{MAX}$ 4-20 mA (OUT. FREQ. 4-20 mA)		[30]	[30]
Output frequency (pulse sequence), 0 - $f_{MAX}$ 0-32000 p (OUT. FREQ. PULSE)		[31]	[31]
External reference, $Ref_{MIN}$ - $Ref_{MAX}$ 0-20 mA (EXT. REF. 0-20 mA)		[32]	[32]
External reference, $Ref_{MIN}$ - $Ref_{MAX}$ 4-20 mA (EXTERNAL REF. 4-20 mA)		[33]	[33]
External reference (pulse sequence), $Ref_{MIN}$ - $Ref_{MAX}$ 0-32000 p (EXTERNAL REF. PULSE)		[34]	[34]
Feedback, $FB_{MIN}$ - $FB_{MAX}$ 0-20 mA (FEEDBACK 0-20 mA)		[35]	[35]
Feedback, $FB_{MIN}$ - $FB_{MAX}$ 4-20 mA (FEEDBACK 4-20 mA)		[36]	[36]
Feedback (pulse sequence), $FB_{MIN}$ - $FB_{MAX}$ 0 - 32000 p (FEEDBACK PULSE)		[37]	[37]
Output current, 0 - $I_{MAX}$ 0-20 mA (MOTOR CUR. 0- 20 mA)		[38]★	[38]
Output current, 0 - $I_{MAX}$ 4-20 mA (MOTOR CUR. 4- 20 mA)		[39]	[39]
Output current (pulse sequence), 0 - $I_{MAX}$ 0 - 32000 p (MOTOR CUR. PULSE)		[40]	[40]
Output power, 0 - $P_{NOM}$ 0-20 mA (MOTOR POWER 0-20 mA)		[41]	[41]
Output power, 0 - $P_{NOM}$ 4-20 mA (MOTOR POWER 4-20 mA)		[42]	[42]
Output power (pulse sequence), 0 - $P_{NOM}$ 0- 32000 p (MOTOR POWER PULSE)		[43]	[43]
Bus control, 0.0-100.0% 0-20 mA (BUS CONTROL 0-20 MA)		[44]	[44]
Bus control, 0.0-100.0% 4-20 mA (BUS CONTROL 4-20 MA)		[45]	[45]
Bus control (pulse sequence), 0.0-100.0% 0 - 32.000 Pulses (BUS CONTROL PULS)		[46]	[46]
Fire mode active (FIRE MODE ACTIVE)		[47]	[47]
Fire mode bypass (FIRE MODE BYPASS)		[48]	[48]

★ = factory setting. () = display text [] = value for use in communication via serial communication port

**319 Terminal 42, output**

**(AO 42 FUNCTION)**

**Function:**

This output can act both as a digital or an analog output. If used as a digital output (data value [0]-[59]), a 0/24 V DC signal is transmitted; if used as an analog output, either a 0-20 mA signal, a 4-20 mA signal or a pulse sequence of 0-32000 pulses is transmitted.

**Description of choice:**

**No function.** Selected if the frequency converter is not to react to signals.

**Drive ready.** The frequency converter control card receives a supply voltage and the frequency converter is ready for operation.

**Stand by.** The frequency converter is ready for operation, but no start command has been given. No warning.

**Running** Is active when there is a start command or the output frequency is above 0.1 Hz.

**Running at ref. value.** Speed according to reference.

**Running, no warning.** A start command has been given. No warning.

**Local reference active.** The output is active when the motor is controlled by means of the local reference via the control unit.

**Remote references active.** The output is active when the frequency converter is controlled by means of the remote references.

**Alarm.** The output is activated by an alarm.

**Alarm or warning.** The output is activated by an alarm or a warning.

**No alarm.** The output is active when there is no alarm.

**Current limit.** The output current is greater than the value programmed in parameter 215 *Current limit*  $I_{LIM}$ .

**Safety interlock.** The output is active when terminal 27 is a logic '1' and *Safety interlock* has been selected on the input.

**Start command active.** A start command has been given.

**Reversing.** There is 24 V DC on the output when the motor rotates anti-clockwise. When the motor rotates clockwise, the value is 0 V DC.

**Thermal warning.** The temperature limit in either the motor, the frequency converter or a thermistor connected to an analog input has been exceeded.

**Hand mode active.** The output is active when the frequency converter is in Hand mode.

**Auto mode active.** The output is active when the frequency converter is in Auto mode.

**Sleep mode.** Active when the frequency converter is in Sleep mode.

**Output frequency lower than  $f_{LOW}$ .** The output frequency is lower than the value set in parameter 223 *Warning: Low frequency,  $f_{LOW}$ .*

**Output frequency higher than  $f_{HIGH}$ .** The output frequency is higher than the value set in parameter 224 *Warning: High frequency,  $f_{HIGH}$ .*

**Out of frequency range.** The output frequency is outside the frequency range programmed in parameter 223 *Warning: Low frequency,  $f_{LOW}$*  and 224 *Warning: High frequency,  $f_{HIGH}$ .*

**Output current lower than  $I_{LOW}$ .** The output current is lower than the value set in parameter 221 *Warning: Low current,  $I_{LOW}$ .*

**Output current higher than  $I_{HIGH}$ .** The output current is higher than the value set in parameter 222 *Warning: High current,  $I_{HIGH}$ .*

**Out of current range.** The output current is outside the range programmed in parameter 221 *Warning: Low current,  $I_{LOW}$*  and 222 *Warning, High current,  $I_{HIGH}$ .*

**Out of feedback range.** The feedback signal is outside the range programmed in parameter 227 *Warning: Low feedback,  $FB_{LOW}$*  and 228 *Warning: High feedback,  $FB_{HIGH}$ .*

**Out of reference range.** The reference lies outside the range programmed in parameter 225 *Warning: Low reference,  $Ref_{LOW}$*  and 226 *Warning, High reference,  $Ref_{HIGH}$ .*

**Relay 123.** This function is only used when a profibus option card is installed.

**Mains imbalance.** This output is activated at too high mains imbalance or when a phase is missing in the mains supply. Check the mains voltage to the frequency converter.

★ = factory setting. () = display text [] = value for use in communication via serial communication port

**0-f<sub>MAX</sub>** **0-20 mA** and

**0-f<sub>MAX</sub>** **4-20 mA** and

**0-f<sub>MAX</sub>** **0-32000 p** which generates an output signal proportional to the output frequency in the interval 0 - f<sub>MAX</sub> (parameter 202 *Output frequency, high limit, f<sub>MAX</sub>*).

**External Ref<sub>min</sub> - Ref<sub>max</sub>** **0-20 mA** and

**External Ref<sub>min</sub> - Ref<sub>max</sub>** **4-20 mA** and

**External Ref<sub>min</sub> - Ref<sub>max</sub>** **0-32000 p** which generates an output signal proportional to the resulting reference value in the interval *Minimum reference, Ref<sub>MIN</sub>* - *Maximum reference, Ref<sub>MAX</sub>* (parameters 204/205).

**FB<sub>MIN</sub>-FB<sub>MAX</sub>** **0-20 mA** and

**FB<sub>MIN</sub>-FB<sub>MAX</sub>** **4-20 mA** and

**FB<sub>MIN</sub>-FB<sub>MAX</sub>** **0-32000 p**, an output signal proportional to the reference value in the interval *Minimum feedback, FB<sub>MIN</sub>* - *Maximum feedback, FB<sub>MAX</sub>* (parameters 413/414) is obtained.

**0 - I<sub>VLT, MAX</sub>** **0-20 mA** and

**0 - I<sub>VLT, MAX</sub>** **4-20 mA** and

**0 - I<sub>VLT, MAX</sub>** **0-32000 p**, an output signal proportional to the output current in the interval 0 - I<sub>VLT,MAX</sub> is obtained.

**0 - P<sub>NOM</sub>** **0-20 mA** and

**0 - P<sub>NOM</sub>** **4-20 mA** and

**0 - P<sub>NOM</sub>** **0-32000p**, which generates an output signal proportional to the present output power. 20 mA corresponds to the value set in parameter 102 *Motor power, P<sub>M,N</sub>*.

**0.0 - 100.0%** **0 - 20 mA** and

**0.0 - 100.0%** **4 - 20 mA** and

**0.0 - 100.0%** **0 - 32.000** pulses which generates an output signal proportional to the value (0.0-100.0%) received by serial communication. Writing from Serial communication is done to parameter 364 (terminal 42) and 365 (terminal 45). This function is limited to the following protocols: FC bus, Profibus, LonWorks FTP, DeviceNet, Metasys N2 and Modbus RTU.

**Fire Mode** active is indicated on the output when activated via input 16 or 17.

**Fire Mode bypass** is indicated on the output when Fire Mode has been active and a certain trip occurred (please see description of Fire Mode). A

★ = factory setting. () = display text [] = value for use in communication via serial communication port

delay for this indication can be programmed in parameter 432. Please select Fire Mode bypass in parameter 430 to enable this function.

### 320 Terminal 42, output, pulse scaling (AO 42 PULS SCALE)

**Value:**

1 - 32000 Hz

★ 5000 Hz

**Function:**

This parameter allows scaling of the pulse output signal.

**Description of choice:**

Set the desired value.

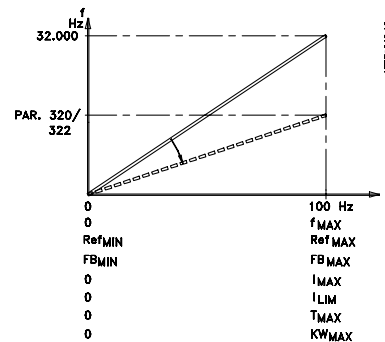

### 321 Terminal 45, output (AO 45 FUNCTION)

**Value:**

See description of parameter 319 *Terminal 42, Output*.

**Function:**

This output can function both as a digital or an analog output. When used as a digital output (data value [0]-[26]) it generates a 24 V (max. 40 mA) signal. For the analog outputs (data value [27] - [41]) there is a choice of 0-20 mA, 4-20 mA or a pulse sequence.

**Description of choice:**

See description of parameter 319 *Terminal 42, Output*.

### 322 Terminal 45, output, pulse scaling (AO 45 PULS SCALE)

#### Value:

1 - 32000 Hz

★ 5000 Hz

#### Function:

This parameter allows scaling of the pulse output signal.

#### Description of choice:

Set the desired value.

### ■ Relay outputs

Relay outputs 1 and 2 can be used to give the present status or a warning.

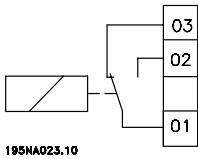

Relay 1  
1 - 3 break, 1 - 2 make  
Max. 240 V AC, 2 Amp.  
The relay is placed with the mains and motor terminals.

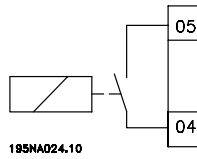

Relay 2  
4 - 5 make  
Max. 50 V AC, 1 A, 60 VA.  
Max. 75 V DC, 1 A, 30 W.  
The relay is placed on the control card, see *Electrical installation, control cables*.

Relay outputs	Relay no. parameter	1 323	2 326
Value:			
No function (NO FUNCTION)		[0]	[0]
Ready signal (READY)		[1]	[1]
Standby (STAND BY)		[2]	[2]
Running (RUNNING)		[3]	[3]★
Running at ref. value (RUNNING AT REFERENCE)		[4]	[4]
Running, no warning (RUNNING NO WARNING)		[5]	[5]
Local reference active (DRIVE IN LOCAL REF)		[6]	[6]
Remote references active (DRIVE IN REMOTE REF.)		[7]	[7]
Alarm (ALARM)		[8]★	[8]
Alarm or warning (ALARM OR WARNING)		[9]	[9]
No alarm (NO ALARM)		[10]	[10]
Current limit (CURRENT LIMIT)		[11]	[11]
Safety interlock (SAFETY INTERLOCK)		[12]	[12]
Start command active (START SIGNAL APPLIED)		[13]	[13]
Reversing (RUNNING IN REVERSE)		[14]	[14]
Thermal warning (THERMAL WARNING)		[15]	[15]
Hand mode active (DRIVE IN HAND MODE)		[16]	[16]
Auto mode active (DRIVE IN AUTO MODE)		[17]	[17]
Sleep mode (SLEEP MODE)		[18]	[18]
Output frequency lower than $f_{LOW}$ parameter 223 (F OUT < F LOW)		[19]	[19]
Output frequency higher than $f_{HIGH}$ parameter 224 (F OUT > F HIGH)		[20]	[20]
Out of frequency range (FREQ RANGE WARN.)		[21]	[21]
Output current lower than $I_{LOW}$ parameter 221 (I OUT < I LOW)		[22]	[22]
Output current higher than $I_{HIGH}$ parameter 222 (I OUT > I HIGH)		[23]	[23]
Out of current range (CURRENT RANGE WARN.)		[24]	[24]
Out of feedback range (FEEDBACK RANGE WARN.)		[25]	[25]
Out of reference range (REFERENCE RANGE WARN.)		[26]	[26]
Relay 123 (RELAY 123)		[27]	[27]
Mains imbalance (MAINS IMBALANCE)		[28]	[28]
Control word 11/12 (CONTROL WORD 11/12)		[29]	[29]
Fire mode active (FIRE MODE ACTIVE)		[30]	[30]
Fire mode bypass (FIRE MODE BYPASS)		[31]	[31]

**Function:**
**Description of choice:**

See description of [0] - [31] in *Analogue/digital outputs*.

**Control word bit 11/12**, relay 1 and relay 2 can be activated via the serial communication. Bit 11 activates relay 1 and bit 12 activates relay 2.

If the parameter *556 Bus time interval function* becomes active, relay 1 and relay 2 will become cut off if they are activated via the *serial communication*. See *paragraph Serial communication* in the *Design Guide*.

**323 Relay 1, output function**
**(RELAY1 FUNCTION)**
**Function:**

This output activates a relay switch. Relay switch 01 can be used for indicating status and warnings. The relay is activated when the conditions for the relevant data values have been fulfilled. Activation/deactivation can be programmed in parameter 324 *Relay 1, ON delay* and parameter 325 *Relay 1, OFF delay*. See *General technical data*.

★ = factory setting. () = display text [] = value for use in communication via serial communication port



**Description of choice:**

See data choice and connections in *Relay outputs*.

**324 Relay 01, ON delay**

**(RELAY1 ON DELAY)**

**Value:**

0 - 600 sec. ★ 0 sec.

**Function:**

This parameter allows a delay of the cut-in time of relay 1 (terminals 1-2).

**Description of choice:**

Enter the desired value.

**325 Relay 01, OFF delay**

**(RELAY1 OFF DELAY)**

**Value:**

0 - 600 sec. ★ 0 sec.

**Function:**

This parameter makes it possible to delay the cut-out time of relay 01 (terminals 1-2).

**Description of choice:**

Enter the desired value.

**326 Relay 2, output function**

**(RELAY2 FUNCTION)**

**Value:**

See functions of relay 2 on previous page.

**Function:**

This output activates a relay switch. Relay switch 2 can be used for indicating status and warnings. The relay is activated when the conditions for the relevant data values have been fulfilled.

See *General technical data*.

**Description of choice:**

See data choice and connections in *Relay outputs*.

**327 Pulse reference, max. frequency**

**(PULSE REF. MAX)**

**Value:**

100 - 65000 Hz at terminal 29 ★ 5000 Hz  
100 - 5000 Hz at terminal 17

**Function:**

This parameter is used to set the pulse value that must correspond to the maximum reference, parameter 205 *Maximum reference, Ref<sub>MAX</sub>*.

The pulse reference signal can be connected via terminal 17 or 29.

**Description of choice:**

Set the required maximum pulse reference.

**328 Pulse feedback, max. frequency**

**(PULSE FDBK MAX.)**

**Value:**

100 - 65000 Hz at terminal 33 ★ 25000 Hz

**Function:**

This is where the pulse value that must correspond to the maximum feedback value is set. The pulse feedback signal is connected via terminal 33.

**Description of choice:**

Set the desired feedback value.

★ = factory setting. () = display text [] = value for use in communication via serial communication port

**364 Terminal 42, bus control****(CONTROL OUTPUT 42)****365 Terminal 45, bus control****(CONTROL OUTPUT 45)****Value:**

0.0 - 100 %

★ 0

**Function:**

Through serial communication, a value between 0.1 and 100.0 is written to the parameter.

The parameter is hidden and cannot be seen from the LCP.

---

### Application functions 400-427

175M407/10

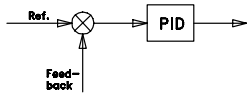

In this parameter group, the special functions the frequency converter are set up, e.g. PID regulation,

setting of the feedback range and the Setup of the Sleep mode function.

Additionally, this parameter group includes:

- Reset function.
- Flying start.
- Option of interference reduction method.
- Setup of any function upon loss of load, e.g. because of a damaged V-belt.
- Setting of switching frequency.
- Selection of process units.

#### 400 Reset function (RESET FUNCTIO)

##### Value:

★ Manual reset (MANUAL RESET)	[0]
Automatic reset x 1 (AUTOMATIC X 1)	[1]
Automatic reset x 2 (AUTOMATIC X 2)	[2]
Automatic reset x 3 (AUTOMATIC X 3)	[3]
Automatic reset x 4 (AUTOMATIC X 4)	[4]
Automatic reset x 5 (AUTOMATIC X 5)	[5]
Automatic reset x 10 (AUTOMATIC X 10)	[6]
Automatic reset x 15 (AUTOMATIC X 15)	[7]
Automatic reset x 20 (AUTOMATIC X 20)	[8]
Infinite automatic reset (INFINITE AUTOMATIC)	[9]

##### Function:

This parameter allows a choice of whether to reset and restart manually after a trip, or whether the frequency converter is to be reset and restarted automatically. In addition, there is a choice of the number of times the unit is to attempt a restart. The time between each reset attempt is set in parameter 401, *Automatic restart time*.

##### Description of choice:

If Manual reset [0] is selected, resetting must be effected via the "Reset" key or via a digital input. If the frequency converter is to carry out an automatic reset and restart after a trip, select data value [1]-[9].



The motor may start without warning.

#### 401 Automatic restart time (AUTORESTART TIME)

##### Value:

0 - 1800 sec. ★ 10 sec.

##### Function:

This parameter allows setting of the time from tripping until the automatic reset function begins. It is assumed that automatic reset has been selected in parameter 400 *Reset* function.

##### Description of choice:

Set the desired time.

#### 402 Flying start (FLYING START)

##### Value:

★ Disable (DISABLE)	[0]
Enable (ENABLE)	[1]
DC brake and start (DC BRAKE AND START)	[3]

##### Function:

This function makes it possible for the frequency converter to 'catch' a spinning motor, which - e.g. because of a mains failure - is no longer controlled by the frequency converter.

This function is activated whenever a start command is active.

For the frequency converter to be able to catch the spinning motor, the motor speed must be lower than the frequency that corresponds to the frequency in parameter 202 *Output frequency high limit*,  $f_{MAX}$ .

##### Description of choice:

Select *Disable* [0] if this function is not required.

Select *Enable* [1] if the frequency converter is to be able to 'catch' and control a spinning motor.

Select *DC brake and start* [2] if the frequency converter is to brake the motor by means of the DC brake first, and then start. It is assumed that parameters 114-116 *DC braking* are enabled. In the case of a substantial 'windmilling' effect (spinning motor), the frequency converter is not able to 'catch' a spinning motor unless DC brake and start has been selected.



When parameter 402, *Flying Start*, is enabled, motor may turn in forward and backward directions a few revolutions even with no speed reference applied.

### ■ Sleep mode

Sleep mode makes it possible to stop the motor when it is running at low speed, similar to a no load situation. If consumption in the system goes back up, the frequency converter will start the motor and supply the power required.



#### NB!:

Energy can be saved with this function, since the motor is only in operation when the system needs it.

Sleep mode is not active if *Local reference* or *Jog* has been selected

The function is active in both *Open loop* and *Closed loop*.

In parameter 403 *Sleep mode timer*, the Sleep mode is activated. In parameter 403 *Sleep mode timer*, a timer is set that determines how long the output frequency can be lower than the frequency set in parameter 404 *Sleep frequency*. When the timer runs out, the frequency converter will ramp down the motor to stop via parameter 207 *Ramp-down time*. If the output frequency rises above the frequency set in parameter 404 *Sleep frequency*, the timer is reset.

While the frequency converter has stopped the motor in sleep mode, a theoretical output frequency is calculated on the basis of the reference signal. When the theoretical output frequency rises above the frequency in parameter 405 *Wake up frequency*, the frequency converter will restart the motor and the output frequency will ramp up to the reference.

In systems with constant pressure regulation, it is advantageous to provide extra pressure to the system before the frequency converter stops the motor. This extends the time during which the frequency converter has stopped the motor and helps to avoid frequent starting and stopping of the motor, e.g. in the case of system leaks.

If 25% more pressure is required before the frequency converter stops the motor, parameter 406 *Boost setpoint* is set to 125%.

Parameter 406 *Boost setpoint* is only active in *Closed loop*.



#### NB!:

In highly dynamic pumping processes, it is recommended to switch off the *Flying Start* function (parameter 402).

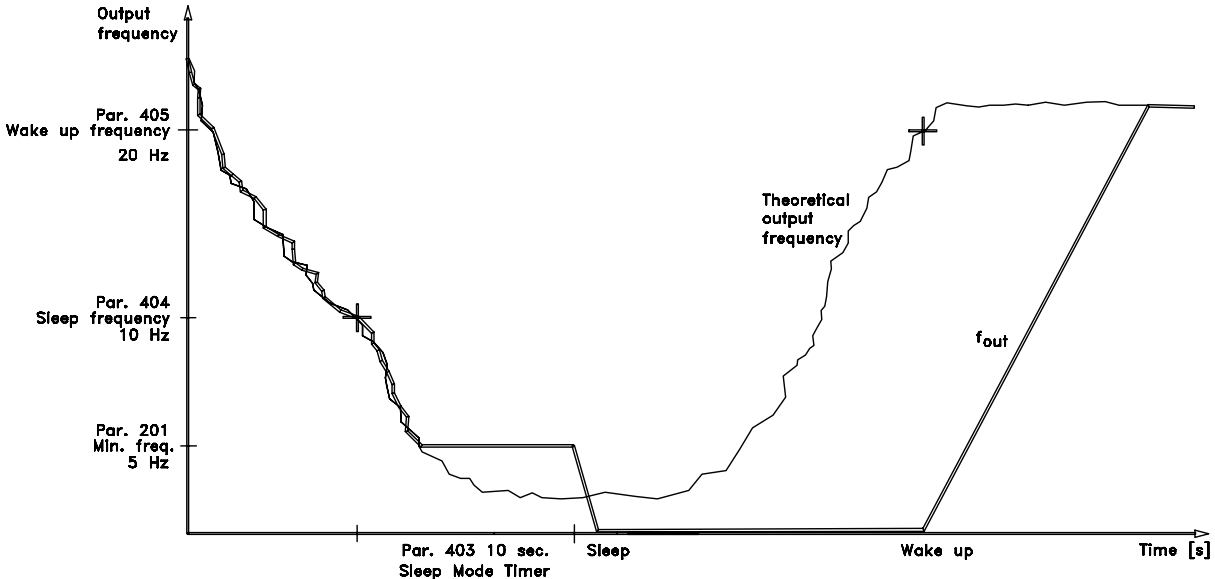

175H4346.14

### 403 Sleep mode timer

#### (SLEEP MODE TIMER)

##### Value:

0 - 300 sec. (301 sec. = OFF) ★ OFF

##### Function:

This parameter enables the frequency converter to stop the motor if the load on the motor is minimal. The timer in parameter 403 *Sleep mode timer* starts when the output frequency drops below the frequency set in parameter 404 *Sleep frequency*. When the time set in the timer has expired, the frequency converter will turn off the motor. The frequency converter will restart the motor, when the theoretical output frequency exceeds the frequency in parameter 405 *Wake up frequency*.

##### Description of choice:

Select OFF if this function is not wanted. Set the threshold value that is to activate Sleep mode after the output frequency has fallen below parameter 404 *Sleep frequency*.

### 404 Sleep frequency

#### (SLEEP FREQUENCY)

##### Value:

000,0 - par. 405 *Wake up frequency* ★ 0.0 Hz

##### Function:

When the output frequency falls below the preset value, the timer will start the time count set in parameter 403 *Sleep mode*. The present output frequency will follow the theoretical output frequency until  $f_{MIN}$  is reached.

##### Description of choice:

Set the required frequency.

### 405 Wake up frequency

#### (WAKEUP FREQUENCY)

##### Value:

Par 404 *Sleep frequency* - par. 202  $f_{MAX}$  ★ 50 Hz

##### Function:

When the theoretical output frequency exceeds the preset value, the frequency converter restarts the motor.

##### Description of choice:

Set the required frequency.

### 406 Boost setpoint

#### (BOOST SETPOINT)

##### Value:

1 - 200 % ★ 100 % of setpoint

##### Function:

This function can only be used if *Closed loop* has been selected in parameter 100. In systems with constant pressure regulation, it is advantageous to increase the pressure in the system before the frequency converter stops the motor. This extends the time during which the frequency converter stops the motor and helps to avoid frequent starting and stopping of the motor, e.g. in the case of leaks in the water supply system.

Use *Boost Time-Out*, par. 472, to set the boost time-out. If the boost set-point cannot be reached within the specified time, the frequency converter will continue in normal operation (Not entering sleep mode).

##### Description of choice:

Set the required *Boost setpoint* as a percentage of the resulting reference under normal operation. 100% corresponds to the reference without boost (supplement).

### 407 Switching frequency

#### (SWITCHING FREQ.)

##### Value:

Depends on the size of the unit.

##### Function:

The preset value determines the switching frequency of the inverter, provided *Fixed switching frequency* [1] has been selected in parameter 408 *Interference reduction method*. If the switching frequency is changed, this may help to minimise possible acoustic noise from the motor.



##### NB!:

The output frequency of the frequency converter can never assume a value higher than 1/10 of the switching frequency.

##### Description of choice:

When the motor is running, the switching frequency is adjusted in parameter 407 *Switching frequency*, until the frequency has been achieved at which the motor is as quiet as possible.



### NB!

Switching frequencies higher than 4.5 kHz implement automatic derating of the maximum output of the frequency converter. See

*Derating of high switching frequency.*

### 408 Interference reduction method (NOISE REDUCTION)

#### Value:

★ASFM (ASFM)	[0]
Fixed switching frequency (FIXED SWITCHING FREQ.)	[1]
LC-filter fitted (LC-FILTER CONNECTED)	[2]

#### Function:

Used to select different methods for reducing the amount of acoustic interference from the motor.

#### Description of choice:

*ASFM* [0] guarantees that the maximum switching frequency, determined by parameter 407, is used at all times without derating of the frequency converter. This is done by monitoring the load.  
*Fixed switching frequency* [1] makes it possible to set a fixed high/low switching frequency. This can generate the best result, as the switching frequency can be set to lie outside the motor interference or in a less irritating area. The switching frequency is adjusted in parameter 407 *Switching frequency*. *LC-filter fitted* [2] is to be used if an LC-filter is fitted between the frequency converter and the motor, as the frequency converter will otherwise not be able to protect the LC-filter.

Note: *ASFM* has no function for VLT 6402-6602, 380-460 V and 6102-6652, 525-600 V.

### 409 Function in case of no load (FUNCT. LOW CURR.)

#### Value:

Trip (TRIP)	[0]
★Warning (WARNING)	[1]

#### Function:

This parameter can be used e.g. for monitoring the V-belt of a fan to make sure it has not snapped. This function is activated when the output current goes below parameter 221 *Warning: Low current*.

#### Description of choice:

In the case of a *Trip* [1], the frequency converter will stop the motor.

★ = factory setting. () = display text [] = value for use in communication via serial communication port

If *Warning* [2] is selected, the frequency converter will give a warning if the output current drops below the threshold value in parameter 221 *Warning: Low current, I<sub>LOW</sub>*.

### 410 Function at mains failure (MAINS FAILURE)

#### Value:

★Trip (TRIP)	[0]
Autoderate & warning (AUTODERATE & WARNING)	[1]
Warning (WARNING)	[2]

#### Function:

Select the function which is to be activated if the mains imbalance becomes too high or if a phase is missing.

#### Description of choice:

At *Trip* [0] the frequency converter will stop the motor within a few seconds (depending on drive size).  
If *Autoderate & warning* [1] is selected, the drive will export a warning and reduce the output current to 30 % of  $I_{VLT,N}$  to maintain operation.  
At *Warning* [2] only a warning will be exported when a mains failure occurs, but in severe cases, other extreme conditions might result in a trip.



### NB!

If *Warning* has been selected, the life expectancy of the drive will be reduced when the mains failure persists.



### NB!

At phase loss, the cooling fans cannot be powered and the frequency converter might trip on overheating. This applies to:

#### IP 00/IP 20/NEMA 1

- VLT 6042-6062, 200-240 V
- VLT 6152-6602, 380-460 V
- VLT 6102-6652, 525-600 V

#### IP 54

- VLT 6006-6062, 200-240 V
- VLT 6016-6602, 380-460 V
- VLT 6016-6652, 525-600 V

### 411 Function at overtemperature (FUNCT. OVERTEMP)

#### Value:

★Trip (TRIP)	[0]
Autoderate & warning (AUTODERATE & WARNING)	[1]

### Function:

Select the function which is to be activated when the frequency converter is exposed to an overtemperature condition.

### Description of choice:

At *Trip* [0] the frequency converter will stop the motor and export an alarm.  
At *Autoderate & warning* [1] the frequency converter will first reduce the switching frequency to minimize internal losses. If the overtemperature condition persists, the frequency converter will reduce the output current until the heat sink temperature stabilizes. When the function is active, a warning will be exported.

### 412 Trip delay overcurrent, $I_{LIM}$

#### (OVERLOAD DELAY)

### Value:

0 - 60 sec. (61=OFF) . ★ 60 sec

### Function:

When the frequency converter registers that the output current has reached the current limit  $I_{LIM}$  (parameter 215 *Current limit*) and stays there for the duration selected, a cut-out will be performed.

### Description of choice:

Select for how long the frequency converter is to able to keep up with the output current at the current limit  $I_{LIM}$  before it cuts out.  
In OFF mode, parameter 412 *Trip delay overcurrent* ,  $I_{LIM}$  is inactive, i.e. cut-outs are not performed.

### ■ Feedback signals in open loop

Normally, feedback signals and thus feedback parameters are only used in *Closed loop* operation; in VLT 6000 HVAC units, however, the feedback parameters are also active in *Open loop* operation. In *Open loop* mode, the feedback parameters can be used to show a process value in the display. If the present temperature is to be displayed, the temperature range can be scaled in parameters 413/414 *Minimum/ Maximum feedback*, and the unit (°C, °F) in parameter 415 *Process units*.

### 413 Minimum feedback , $FB_{MIN}$

#### (MIN. FEEDBACK)

### Value:

-999,999.999 -  $FB_{MAX}$  ★ 0.000

### Function:

Parameters 413 *Minimum feedback*,  $FB_{MIN}$  and 414 *Maximum feedback*,  $FB_{MAX}$  are used to scale the display indication, thereby ensuring that it shows the feedback signal in a process unit proportionally to the signal at the input.

### Description of choice:

Set the value to be shown on the display at minimum feedback signal value (par. 309, 312, 315 *Min. scaling*) on the selected feedback input (parameters 308/311/314 *Analog inputs*).

### 414 Maximum feedback, $FB_{MAX}$

#### (MAX. FEEDBACK)

### Value:

$FB_{MIN}$  - 999,999.999 ★ 100.000

### Function:

See the description of par. 413 *Minimum feedback*,  $FB_{MIN}$ .

### Description of choice:

Set the value to be shown on the display when maximum feedback (par. 310, 313, 316 *Max. scaling*) has been achieved at the selected feedback input (parameters 308/311/314 *Analog inputs*).

### 415 Units relating to closed loop

#### (REF. / FDBK. UNIT)

### Value:

No unit	[0]
★%	[1]
rpm	[2]
ppm	[3]
pulse/s	[4]
l/s	[5]
l/min	[6]
l/h	[7]
kg/s	[8]
kg/min	[9]
kg/h	[10]
m <sup>3</sup> /s	[11]
m <sup>3</sup> /min	[12]
m <sup>3</sup> /h	[13]
m/s	[14]

★ = factory setting. () = display text [] = value for use in communication via serial communication port

mbar	[15]
bar	[16]
Pa	[17]
kPa	[18]
mVS	[19]
kW	[20]
°C	[21]
GPM	[22]
gal/s	[23]
gal/min	[24]
gal/h	[25]
lb/s	[26]
lb/min	[27]
lb/h	[28]
CFM	[29]
ft <sup>3</sup> /s	[30]
ft <sup>3</sup> /min	[31]
ft <sup>3</sup> /h	[32]
ft/s	[33]
in wg	[34]
ft wg	[35]
PSI	[36]
lb/in <sup>2</sup>	[37]
HP	[38]
°F	[39]

**Function:**

Selection of unit to be shown on the display.  
 This unit will be used if *Reference [unit]* [2] or *Feedback [unit]* [3] has been selected in one of the parameters 007-010, as well as in the *Display mode*.  
 In *Closed loop*, the unit is also used as a unit for Minimum/ Maximum reference and *Minimum/Maximum feedback*, as well as *Setpoint 1* and *Setpoint 2*.

**Description of choice:**

Select the required unit for the reference/feed-back signal.

---



**■ PID for process control**

The PID controller maintains a constant process condition (pressure, temperature, flow, etc.) and adjusts motor speed on the basis of a reference/setpoint and the feedback signal. A transmitter supplies the PID controller with a feedback signal from the process to indicate its actual state. The feedback signal varies with the process load. This means that deviations occur between the reference/ setpoint and the actual process state. Such deviations are evened out by the PID regulator, in that it regulates the output frequency up or down in relation to the deviation between the reference/setpoint and the feedback signal. The integral PID regulator in VLT 6000 HVAC units has been optimised for use in HVAC applications. This means that a number of specialised functions are available in VLT 6000 HVAC units. Formerly, it was necessary to get a BMS (Building Management System) to handle these special functions by installing extra I/O modules and by programming the system. Using the VLT 6000 HVAC, there is no need for extra modules to be installed. For example, only one required reference/setpoint and the handling of feedback need to be programmed. There is in-built a option for connecting two feedback signals to the system, making two-zone regulation possible. Correction for voltage losses in long signal cables can be carried out when using a transmitter with a voltage output. This is done in parameter group 300 *Min./ Max. scaling*.

Feedback

The feedback signal must be connected to a terminal on the frequency converter. Use the list below to decide which terminal to use and which parameters to program.

<u>Feedback type</u>	<u>Terminal</u>	<u>Parameters</u>
Pulse	33	307
Voltage	53, 54	308, 309, 310 or 311, 312, 313, 314
Current	60	315, 316
Bus feedback 1	68+69	535
Bus feedback 2	68+69	536

Please note that the feedback value in parameter 535/ 536 *Bus feedback 1 and 2* can only be set via serial communication (not via the control unit).

Furthermore, the *minimum* and *maximum feedback* (parameters 413 and 414) must be set to a value in the process unit that corresponds to the minimum and maximum scaling value for signals connected to the terminal. The process unit is selected in parameter 415 *Process units*.

Reference

In parameter 205 *Maximum reference, Ref<sub>MAX</sub>*, a maximum reference that scales the sum of all references, i.e. the resulting reference, can be set. The *minimum reference* in parameter 204 indicates the smallest value that the resulting reference can assume. The reference range cannot exceed the feedback range. If *Preset references* are required, set these in parameters 211 to 214 *Preset reference*. See *Reference type*. See also *Reference handling*.

If a current signal is used as a feedback signal, voltage can be used as analogue reference. Use the list below to decide which terminal to use and which parameters to program.

<u>Reference type</u>	<u>Terminal</u>	<u>Parameters</u>
Pulse	17 or 29	301 or 305
Voltage	53 or 54	308, 309, 310 or 311, 312, 313
Current	60	314, 315, 316
Preset reference	214	211, 212, 213,
Setpoints		418, 419
Bus reference	68+69	

Please note that the bus reference can only be set via serial communication.

**NB!:**

Terminals that are not in use may preferably be set to *No function* [0].

### ■ PID for process regulation, cont.

#### Inverse regulation

Normal regulation means that the motor speed increases when the reference/setpoint is higher than the feedback signal. If there is a need for inverse regulation, in which the speed is reduced when the reference/setpoint is higher than the feedback signal, inverse must be programmed in parameter 420 *PID normal/inverse control*.

#### Anti Windup

The process regulator is factory preset with an active anti-windup function. This function ensures that when either a frequency limit, current limit or voltage limit reached, the integrator will be initialised for a frequency that corresponds to the present output frequency. This avoids integration on a deviation between the reference/setpoint and the actual state the process, the controller of which is not possible means of a speed change. This function can be disabled in parameter 421 *PID anti windup*.

#### Start-up conditions

In some applications, optimum setting of the process regulator will mean that it takes an excessive time for the required process state to be reached. In such applications it might be an advantage to fix an output frequency to which the frequency converter is to bring the motor before the process regulator is activated. This is done by programming a *PID start-up frequency* in parameter 422.

#### Differentiator gain limit

If there are very quick variations in a given application with respect to the reference/setpoint signal or the feedback signal, the deviation between reference/set-point and the actual process state will quickly change. The differentiator may thus become too dominant. This is because it reacts to the deviation between the reference/setpoint and the actual process state. The quicker the deviation changes, the stronger the resulting differentiator frequency contribution. The differentiator frequency contribution can thus be limited to allow the setting of a reasonable differentiation time for slow changes and a suitable frequency contribution for quick changes. This is done in parameter 426, *PID Differentiator gain limit*.

#### Lowpass filter

If there are ripple currents/voltages on the feedback signal, these can be dampened by means of a built-in lowpass filter. Set a suitable lowpass filter time constant. This time constant represents the limit frequency of the ripples occurring on the feedback signal. If the lowpass filter has been set to 0.1s, the limit frequency will be 10 RAD/sec., corresponding to  $(10 / 2 \times \pi) = 1.6$  Hz. This means that all currents/voltages that vary by more than 1.6 oscillations per second will be removed by the filter. In other words, regulation will only be carried out on a feedback signal that varies by a frequency of less than 1.6 Hz. Choose a suitable time constant in parameter 427, *PID Lowpass filter time*.

#### Optimisation of the process regulator

The basic settings have now been made; all that remains to be done is to optimise the proportional gain, the integration time and the differentiation time (parameters 423, 424 and 425). In most processes, this can be done by following the guidelines given below.

1. Start the motor.
2. Set parameter 423 *PID proportional gain* to 0.3 and increase it until the process shows that the feedback signal is unstable. Then reduce the value until the feedback signal has stabilised. Now lower the proportional gain by 40-60%.
3. Set parameter 424 *PID integration time* to 20 s and reduce the value until the process shows that the feedback signal is unstable. Increase the integration time until the feedback signal stabilises, followed by an increase of 15-50%.
4. Parameter 425 *PID differentiation time* is only used in very fast-acting systems. The typical value is 1/4 of the value set in parameter 424 *PID Integration time*. The differentiator should only be used when the setting of the proportional gain and the integration time have been fully optimised.



#### **NB!**

If necessary, start/stop can be activated a number of times in order to provoke an unstable feedback signal.

■ PID overview

The block diagram below shows reference and setpoint in relation to the feedback signal.

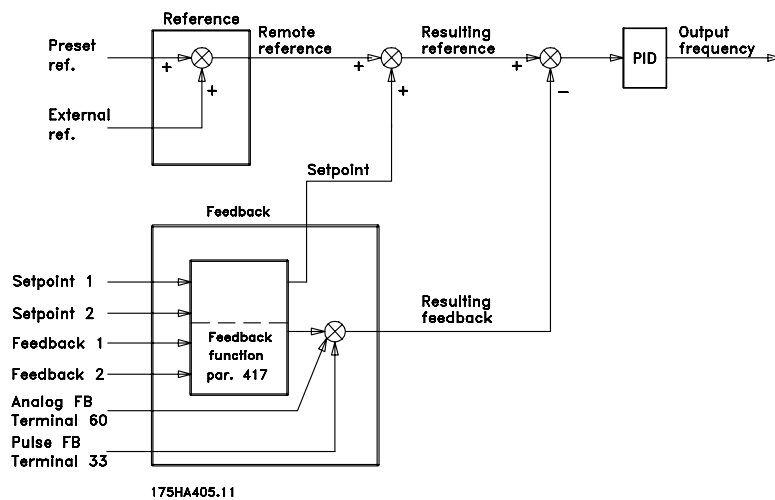

As can be seen, the remote reference is totalled with setpoint 1 or setpoint 2. See also *Reference handling*. Which setpoint is to be totalled with the

remote reference depends on the selection made in parameter 417 *Feedback function*.

■ Feedback handling

The feedback handling can be seen from the block diagram on the next page. The block diagram shows how and by which parameters the feedback handling can be affected. Options as feedback signals are: voltage, current, pulse and bus feedback signals. In zone regulation, feedback signals must be selected as voltage inputs (terminals 53 and 54). Please note that *Feedback 1* consists of bus feedback 1 (parameter 535) totalled with the feedback signal value of terminal 53. *Feedback 2* consists of bus feedback 2 (parameter 536) totalled with the feedback signal value of terminal 54.

In addition, the frequency converter has an integral calculator capable of converting a pressure signal into a "linear flow" feedback signal. This function is activated in parameter 416 *Feedback conversion*.

The parameters for feedback handling are active both in closed and open loop modes. In *open loop*, the present temperature can be displayed by connecting a temperature transmitter to a feedback input.

In a closed loop, there are - roughly speaking - three possibilities of using the integral PID regulator and set-point/ feedback handling:

1. 1 setpoint and 1 feedback
2. 1 setpoint and 2 feedbacks
3. 2 Setpoints and 2 feedbacks

★ = factory setting. () = display text [] = value for use in communication via serial communication port

### 1 setpoint and 1 feedback

If only 1 setpoint and 1 feedback signal are used, parameter 418 *Setpoint 1* will be added to the remote reference. The sum of the remote reference and *Setpoint 1* becomes the resulting reference, which will then be compared with the feedback signal.

### 1 setpoint and 2 feedbacks

Just like in the above situation, the remote reference is added to *Setpoint 1* in parameter 418. Depending

on the feedback function selected in parameter 417 *Feedback function*, a calculation will be made of the feedback signal with which the sum of the references and the setpoint is to be compared. A description of the individual feedback functions is given in parameter 417 *Feedback function*.

### 2 Setpoints and 2 feedbacks

Used in 2-zone regulation, where the function selected in parameter 417 *Feedback function* calculates the setpoint to be added to the remote reference.

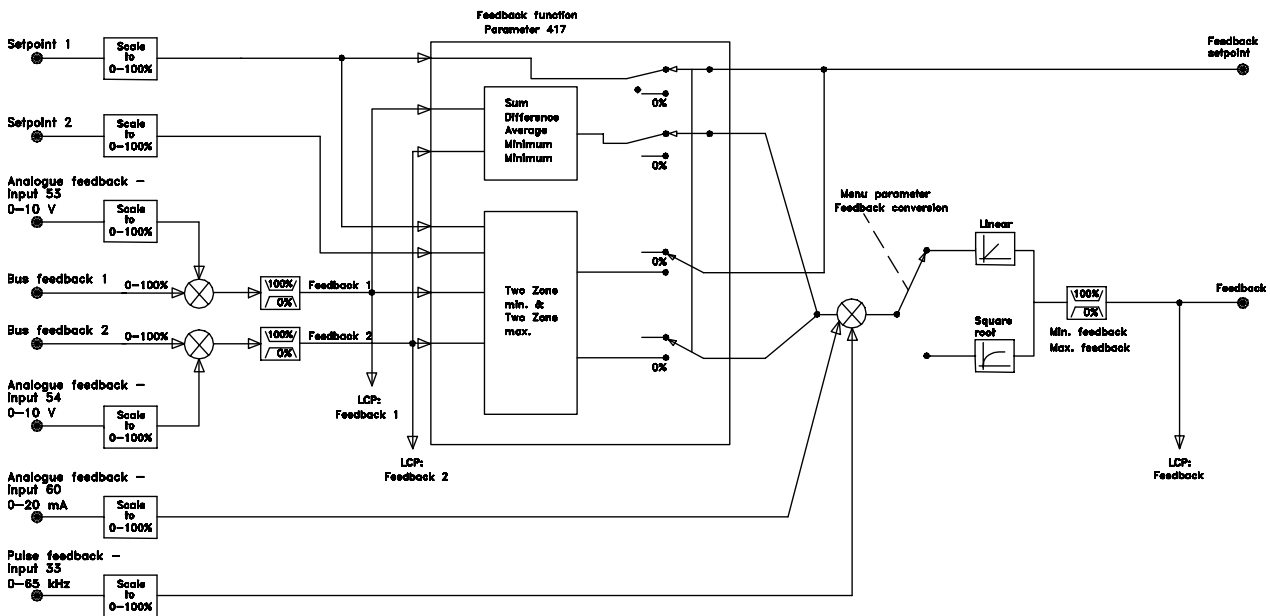

175HA387.11

### 416 Feedback conversion (FEEDBACK CONV.)

#### Value:

- ★ Linear (LINEAR) [0]
- Square root (SQUARE ROOT) [1]

#### Function:

In this parameter, a function is selected which converts a connected feedback signal from the process to a feedback value that equals the square root of the connected signal. This is used, e.g. where regulation of a flow (volume) is required on the basis of pressure as feedback signal (flow = constant  $\times \sqrt{\text{pressure}}$ ). This conversion makes it possible to set the reference in such a way that there is a linear connection between the reference and the flow required. See drawing in next column. Feedback conversion should not be used if 2-zone regulation in parameter 417 *Feedback function* has been selected.

#### Description of choice:

If *Linear* [0] is selected, the feedback signal and the feedback value will be proportional. If *Square root* [1] is selected, the frequency converter translates the feedback signal to a square root value.

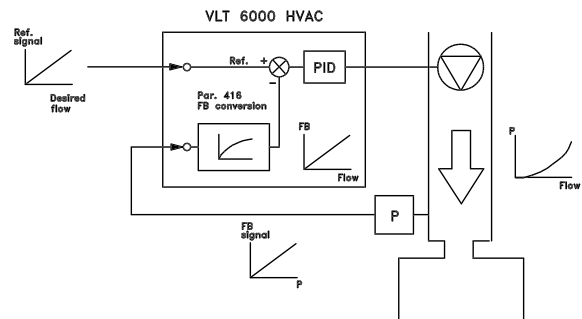

### 417 Feedback function

#### (2 FEEDBACK, CALC.)

##### Value:

Minimum (MINIMUM)	[0]
★Maximum (MAXIMUM)	[1]
Sum (SUM)	[2]
Difference (DIFFERENCE)	[3]
Average (AVERAGE)	[4]
2-zone minimum (2 ZONE MIN)	[5]
2-zone maximum (2 ZONE MAX)	[6]
Feedback 1 only (FEEDBACK 1 ONLY)	[7]
Feedback 2 only (FEEDBACK 2 ONLY)	[8]

##### Function:

This parameter allows a choice between different calculation methods whenever two feedback signals are used.

##### Description of choice:

If *Minimum* [0] is selected, the frequency converter will compare *feedback 1* with *feedback 2* and regulate on the basis of the lower feedback value.

*Feedback 1* = Sum of parameter 535 *Bus feedback 1* and the feedback signal value of terminal 53. *Feedback 2* = Sum of parameter 536 *Bus feedback 2* and the feedback signal value of terminal 54.

If *Maximum* [1] is selected, the frequency converter will compare *feedback 1* with *feedback 2* and regulate on the basis of the higher feedback value.

If *Sum* [2] is selected, the frequency converter will total *feedback 1* with *feedback 2*. Please note that the remote reference will be added to *Setpoint 1*.

If *Difference* [3] is selected, the frequency converter will subtract *feedback 1* from *feedback 2*.

If *Average* [4] is selected, the frequency converter will calculate the average of *feedback 1* and *feedback 2*. Please note that the remote reference will be added to the *Setpoint 1*.

If *2-zone minimum* [5] is selected, the frequency converter will calculate the difference between *Setpoint 1* and *feedback 1* as well as *Setpoint 2* and *feedback 2*. After this calculation, the frequency converter will use the larger difference. A positive difference, i.e. a setpoint higher than the feedback, is always larger than a negative difference.

If the difference between *Setpoint 1* and *feedback 1* is the larger of the two, parameter 418 *Setpoint 1* will be added to the remote reference.

If the difference between *Setpoint 2* and *feedback 2* is the larger of the two, the remote reference will be added to the parameter 419 *Setpoint 2*. If *2-zone maximum* [6] is selected, the frequency converter

will calculate the difference between *Setpoint 1* and *feedback 1* as well as *Setpoint 2* and *feedback 2*.

After the calculation, the frequency converter will use the smaller difference. A negative difference, i.e. one where the setpoint is lower than the feedback, is always smaller than a positive difference.

If the difference between *Setpoint 1* and *feedback 1* is the smaller of the two, the remote reference will be added to the parameter 418 *Setpoint 1*.

If the difference between *Setpoint 2* and *feedback 2* is the smaller of the two, the remote reference will be added to parameter 419 *Setpoint 2*.

If *Feedback 1 only* [7] is selected, terminal 53 is read as the feedback signal and terminal 54 ignored. Feedback 1 is compared to *Setpoint 1* for drive control. If *Feedback 2 only* [8] is selected, terminal 54 is read as the feedback signal and terminal 53 ignored. Feedback 2 is compared to *Setpoint 2* for drive control.

### 418 Setpoint 1

#### (SETPOINT 1)

##### Value:

Ref<sub>MIN</sub> - Ref<sub>MAX</sub> ★ 0.000

##### Function:

*Setpoint 1* is used in closed loop as the reference to compare the feedback values with. See description of parameter 417 *Feedback function*. The setpoint can be offset with digital, analog or bus references, see *Reference handling*. Used in *Closed loop* [1] parameter 100 *Configuration*.

##### Description of choice:

Set the required value. The process unit is selected in parameter 415 *Process units*.

### 419 Setpoint 2

#### (SETPOINT 2)

##### Value:

Ref<sub>MIN</sub> - Ref<sub>MAX</sub> ★ 0.000

##### Function:

*Setpoint 2* is used in closed loop as the reference to compare the feedback values with. See description of parameter 417 *Feedback function*.

The setpoint can be offset with digital, analog or bus signals, see *reference handling*.

★ = factory setting. () = display text [] = value for use in communication via serial communication port

Used in *Closed loop* [1] parameter 100 *Configuration* and only if 2-zone minimum/maximum is selected in parameter 417 *Feedbackfunction*.

### Description of choice:

Set the required value. The process unit is selected in parameter 415 *Process units*.

### 420 PID normal/inverse control (PID NOR/INV. CTRL)

#### Value:

★Normal (NORMAL) [0]  
Inverse (INVERSE) [1]

#### Function:

It is possible to choose whether the process regulator is to increase/reduce the output frequency if there is a deviation between reference/setpoint and the actual process state.

Used in *Closed loop* [1] (parameter 100).

### Description of choice:

If the frequency converter is to reduce the output frequency in case the feedback signal increases, select *Normal* [0].

If the frequency converter is to increase the output frequency in case the feedback signal increases, select *Inverse* [1].

### 421 PID anti windup (PID ANTI WINDUP)

#### Value:

Off (DISABLE) [0]  
★On (ENABLE) [1]

#### Function:

It is possible to choose whether the process regulator is to continue regulating on a deviation even if it is not possible to increase/reduce the output frequency. Used in *Closed loop* [1] (parameter 100).

### Description of choice:

The factory setting is *On* [1], which means that the integration link is adjusted to the actual output frequency if either the current limit, the voltage limit or the max./min. frequency has been reached. The process regulator will not be engaged again, until either the deviation is zero or its prefix has changed. Select *Off* [0] if the integrator is to continue integrating to the deviation even if it is not possible to remove the deviation by regulation.



#### NB!:

If *Off* [0] is selected, it will mean that when the deviation changes its prefix, the integrator will first have to integrate down from the level obtained as a result of the former error, before any change to the output frequency occurs.

### 422 PID start-up frequency (PID START VALUE)

#### Value:

$f_{MIN}-f_{MAX}$  (parameter 201 and 202) ★ 0 Hz

#### Function:

When the start signal comes, the frequency converter will react in the form of *Open loop* [0] following the ramp. Only when the programmed start frequency has been obtained, will it change over to *Closed loop* [1]. In addition, it is possible to set a frequency that corresponds to the speed at which the process normally runs, which will enable the required process conditions to be reached sooner.

Used in *Closed loop* [1] (parameter 100).

### Description of choice:

Set the required start frequency.



#### NB!:

If the frequency converter is running at the current limit before the desired start frequency is obtained, the process regulator will not be activated. For the regulator to be activated anyway, the start frequency must be lowered to the required output frequency. This can be done during operation.



#### NB!:

PID start frequency is always applied in clockwise direction.

### 423 PID proportional gain (PID PROP. GAIN)

#### Value:

0.00 - 10.00 ★ 0.01

#### Function:

The proportional gain indicates the number of times the deviation between the reference/setpoint and the feedback signal is to be applied.

Used in *Closed loop* [1] (parameter 100).

### Description of choice:

Quick regulation is obtained by a high gain, but if the gain is too high, the process may become unstable.

### 424 PID integration time

#### (PID INTEGR. TIME)

#### Value:

0.01 - 9999.00 sec. (OFF) ★ OFF

#### Function:

The integrator provides a constant change of the output frequency during constant error between the reference/setpoint and the feedback signal. The greater the error, the quicker the integrator frequency contribution will increase. The integration time is the time needed by the integrator to reach the same gain as the proportional gain for a given deviation. Used in *Closed loop* [1] (parameter 100).

### Description of choice:

Fast regulation is obtained in connection with a short integration time. However, this time

may be too short, which means that the process may be destabilised as a result of overshoots.

If the integral time is long, major deviations from the required set point may occur, since the process regulator will take a long time to regulate in relation to a given error.



#### NB!:

Some value other than OFF must be set or the PID will not function correctly.

### 425 PID differentiation time

#### (PID DIFF. TIME)

#### Value:

0.00 (OFF) - 10.00 sec. ★ OFF

#### Function:

The differentiator does not react to a constant error. It only contributes when the error changes. The quicker the error changes, the stronger the contribution from the differentiator will be. This influence is proportional to the speed by which the deviation changes. Used in *Closed loop* [1] (parameter 100).

### Description of choice:

Fast regulation can be obtained by means of a long differentiation time. However, this time may

be too long, which means that the process may be destabilised as a result of overshoots.

### 426 PID differentiator gain limit

#### (PID DIFF. GAIN)

#### Value:

5.0 - 50.0 ★ 5.0

#### Function:

It is possible to set a limit for the differentiator gain. The differentiator gain will increase if there are fast changes, which is why it can be beneficial to limit this gain, thereby obtaining a pure differentiator gain at slow changes and a constant differentiator gain where quick changes to the deviation are made. Used in *Closed loop* [1] (parameter 100).

### Description of choice:

Select a limit to differentiator gain as required.

### 427 PID lowpass filter time

#### (PID FILTER TIME)

#### Value:

0.01 - 10.00 ★ 0.01

#### Function:

Oscillations on the feedback signal are dampened by the lowpass filter in order to reduce their impact on the process regulation. This can be an advantage if there is a lot of noise on the signal. Used in *Closed loop* [1] (parameter 100).

### Description of choice:

Select the desired time constant ( $\tau$ ). If a time constant ( $\tau$ ) of 0.1 s is programmed, the break frequency for the lowpass filter will be  $1/0.1 = 10 \text{ RAD/sec.}$ , corresponding to  $(10/(2 \times \pi)) = 1.6 \text{ Hz.}$  The process regulator will thus only regulate a feedback signal that varies by a frequency lower than 1.6 Hz. If the feedback signal varies by a higher frequency than 1.6 Hz, the Process regulator will not react.

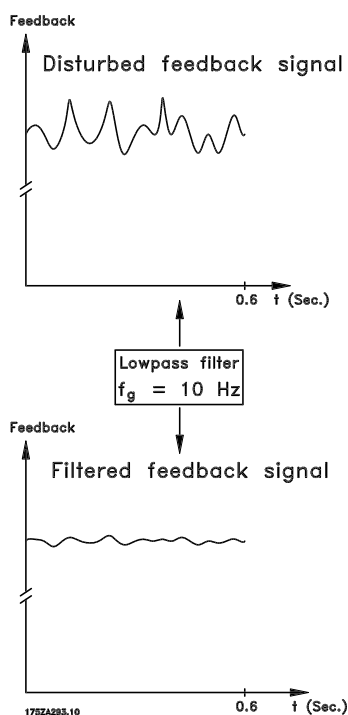

### NB!:

Please note the frequency converter is only one component of the HVAC system.

Correct function of Fire Mode depends on the correct design and selection of system components. Ventilation systems working in life safety applications have to be approved by the local fire Authorities.

**Non-interruption of the frequency converter due to Fire Mode operation may cause over pressure and result in damage to HVAC system and components, hereunder dampers and air ducts. The frequency converter itself may be damaged and it may cause damage or fire.**

**Danfoss A/S accepts no responsibility for errors, malfunctions personal injury or any damage to the frequency converter itself or components herein, HVAC systems and components herein or other property when the frequency converter has been programmed for Fire Mode. In no event shall Danfoss be liable to the end user or any other party for any direct or indirect, special or consequential damage or loss suffered by such party, which has occurred due to the frequency converter being programmed and operated in Fire Mode**

### 430 Fire mode (FIRE MODE)

#### Value:

- ★ Off (DISABLE) [0]
- Open loop forward (OPEN LOOP FWD.) [1]

★ = factory setting. () = display text [] = value for use in communication via serial communication port

Open loop reverse (OPEN LOOP REV.) [2]

Open loop forward bypass (OPL. FWD BYPASS) [3]

#### Function:

The Fire Mode function is made to ensure that the VLT 6000 can run without interruption. This means most alarms and warnings will not cause a trip and trip lock is disabled. This is useful in case of fire or other emergencies. Until the motor wires or the frequency converter itself are destroyed every attempt is made to keep running.

#### Description of choice:

If Disable [0] is selected then Fire Mode is disabled no matter what the selection in parameter 300 and 301 is. If Open loop forward [1] is selected the frequency converter will run in forward direction open loop mode with in parameter 431 selected speed.

If Open loop reverse [2] is selected the frequency converter will run in reverse direction open loop mode with in parameter 431 selected speed.

If Open loop forward bypass [3] is selected the frequency converter will run in forward direction open loop mode with the in parameter 431 selected speed. If an alarm occurs the frequency converter will trip after the in parameter 432 selected time delay has passed.

### 431 Fire mode reference frequency, Hz (FIRE MODE FREQ.)

#### Value:

0.0 -  $f_{max}$  ★ 50.0 Hz

#### Function:

The Fire Mode frequency is the fixed output frequency used when Fire Mode is activated via terminal 16 or 17.

#### Description of choice:

Set the required output frequency to be used during Fire Mode.

### 432 Fire mode bypass delay, s (FIRE M. BYP. DELAY)

#### Value:

0 - 600 sec. ★ 0 sec.

#### Function:

This time delay is used in case the frequency converter trips caused by an alarm. After a trip, and the delay time has passed, an output is set. Please see description of Fire Mode and parameter 319, 321, 323 and 326 for further information.



**Description of choice:**

Set the required time delay before trip and setting the output.

**483 Dynamic DC link compensation**

**(DC LINK COMP.)**

**Value:**

Off	[0]
★On	[1]

**Function:**

The frequency converter includes a feature, which ensures that the output voltage is independent of any voltage fluctuation in the DC link, e.g. caused by fast fluctuation in the mains supply voltage. The benefit is a very steady torque on motor shaft (low torque ripple) under most mains conditions.

**Description of choice:**

In some cases this dynamic compensation can cause resonance's in the DC link and should then be disabled. Typical cases are where a line choke or a passive harmonic filter (e.g. filters AHF005/010) is mounted in the mains supply to the frequency converter to suppress harmonics. Can also occur on mains with low short circuit ratio.

**500 - 566 Serial communication**

**Value:**

All information concerning the use of RS 485 serial interface is not included in this manual. Please contact Danfoss and ask for the VLT 6000 HVAC Design Guide.

★ = factory setting. () = display text [] = value for use in communication via serial communication port

**■ Service functions 600-631**

This parameter group contains functions such as operating data, data log and fault log.

It also has information on the nameplate data of the frequency converter.

These service functions are very useful in connection with operating and fault analysis in an installation.

---

**600-605 Operating data**
**Value:**

Parameter no.	Description	Display text	Unit	Range
<b>Operating data:</b>				
600	Operating hours	(OPERATING HOURS)	Hours	0 - 130,000.0
601	Hours run	(RUNNING HOURS)	Hours	0 - 130,000.0
602	kWh counter	(KWH COUNTER)	kWh	-
603	No. of cut-ins	(POWER UP'S)	Nos.	0 - 9999
604	No. of overtemps.	(OVER TEMP'S)	Nos.	0 - 9999
605	No. of overvoltages	(OVER VOLT'S)	Nos.	0 - 9999

**Function:**

These parameters can be read out via the serial communication port, as well as via the display in the parameters.

**Description of choice:**
**Parameter 600 Operating hours:**

Gives the number of hours in which the frequency converter has been in operation. The value is saved every hour and when the power supply to the unit is cut off. This value cannot be reset.

**Parameter 601 Hours run:**

Gives the number of hours in which the motor has been in operation since being reset in parameter 619 *Reset of hours-run counter*. The value is saved every hour and when the power supply to the unit is cut off.

**Parameter 602 kWh counter:**

Gives the output power of the frequency converter. The calculation is based on the mean value in kWh over one hour. This value can be reset using parameter 618 *Reset of kWh counter*.

**Parameter 603 No. of cut-ins:**

Gives the number of cut-ins of supply voltage to the frequency converter.

**Parameter 604 No. of overtemps:**

Gives the number of overtemperature errors on the heat-sink of the frequency converter.

**Parameter 605 No. of overvoltages:**

Gives the number of overvoltages on the intermediate circuit voltage of the frequency converter. The count is only taken when Alarm 7 *Overvoltage* is active.

---

★ = factory setting. () = display text [] = value for use in communication via serial communication port

### 606 - 614 Data log

#### Value:

Parameter no.	Description	Display text	Unit	Range
	<b>Data log:</b>			
606	Digital input	(LOG: DIGITAL INP)	Decimal	0 - 255
607	Control word	(LOG: BUS COMMAND)	Decimal	0 - 65535
608	Status word	(LOG: BUS STAT WD)	Decimal	0 - 65535
609	Reference	(LOG: REFERENCE)	%	0 - 100
610	Feedback	(LOG: FEEDBACK)	Par. 414	-999,999.999 - 999,999.999
611	Output frequency	(LOG: MOTOR FREQ.)	Hz	0.0 - 999.9
612	Output voltage	(LOG: MOTOR VOLT)	Volt	50 - 1000
613	Output current	(LOG: MOTOR CURR.)	Amp	0.0 - 999.9
614	DC link voltage	(LOG: DC LINK VOLT)	Volt	0.0 - 999.9

#### Function:

With these parameters, it is possible to see up to 20 saved values (data logs) - [1] being the most recent and [20] the oldest log. When a start command has been given, a new entry to the data log is made every 160 ms. If there is a trip or if the motor has stopped, the 20 latest data log entries will be saved and the values will be visible in the display. This is useful, in the case of service after a trip. The data log number is given in square brackets; [1]

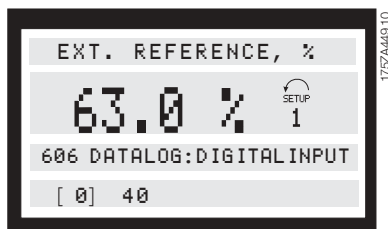

Data logs [1]-[20] can be read by first pressing [CHANGE DATA], followed by the [+/-] keys to change data log numbers. Parameters 606-614 *Data log* can also be read out via the serial communication port.

#### Description of choice:

##### Parameter 606 Data log: Digital input:

This is where the latest log data are shown in decimal code, representing the status of the digital inputs. Translated into binary code, terminal 16 corresponds to the bit to the extreme left and to decimal code 128. Terminal 33 corresponds to the bit to the extreme right and to decimal code 1. The table can be used, e.g., for converting a decimal number into a binary code. For example, digital 40 corresponds to binary 00101000. The nearest smaller decimal number is 32, corresponding to a signal on terminal 18. 40-32 = 8, corresponds to the signal on terminal 27.

Terminal	16	17	18	19	27	29	32	33
Decimal number	128	64	32	16	8	4	2	1

##### Parameter 607 Data log: Control word:

This is where the latest log data are given in decimal code for the control word of the frequency converter. The control word read can only be changed via serial communication. The control work is read as a decimal number which is to be converted into hex.

##### Parameter 608 Data log: Status word:

This gives the latest log data in decimal code for the status word. The status word is read as a decimal number which is to be converted into hex.

##### Parameter 609 Data log: Reference:

This gives the latest log data for the resulting reference.

##### Parameter 610 Data log: Feedback:

This gives the latest log data for the feedback signal.

##### Parameter 611 Data log: Output frequency:

This gives the latest log data for the output frequency.

##### Parameter 612 Data log: Output voltage:

This gives the latest log data for the output voltage.

##### Parameter 613 Data log: Output current:

This gives the latest log data for the output current.

##### Parameter 614 Data log: DC-link voltage:

This gives the latest log data for the intermediate circuit voltage.

★ = factory setting. () = display text [] = value for use in communication via serial communication port

### 615 Fault log: Error code

#### (F. LOG: ERROR CODE)

##### Value:

[Index 1-10] Error Code: 0 - 99

##### Function:

This parameter makes it possible to see the reason why a trip (cut-out of the frequency converter) occurs. 10 [1-10] log values are stored.

The lowest log number [1] contains the latest/most recently saved data value; the highest log number [10] contains the oldest data value.

If there is a trip on the frequency converter, it is possible to see its cause, the time and possibly the values for output current or output voltage.

##### Description of choice:

Stated as an error code in which the number refers to a table in *List of warnings and alarms*.

The fault log is only reset after manual initialization. (See *Manual initialization*).

### 616 Fault log: Time

#### (F. LOG: TIME)

##### Value:

[Index 1-10] Hours: 0 - 130,000.0

##### Function:

This parameter makes it possible to see the total number of hours run in connection with the 10 latest trips.

10 [1-10] log values are stored. The lowest log number [1] contains the latest/most recently saved data value, while the highest log number [10] contains the oldest data value.

##### Description of choice:

The fault log is only reset after manual initialization. (See *Manual initialization*).

### 617 Fault log: Value

#### (F. LOG: VALUE)

##### Value:

[Index 1 - 10] Value: 0 - 9999

##### Function:

This parameter makes it possible to see the value at which a trip occurred. The unit of the value depends on the alarm active in parameter 615 *Fault log: Error code*.

##### Description of choice:

The fault log is only reset after manual initialization. (See *Manual initialization*).

### 618 Reset of kWh counter

#### (RESET KWH COUNT)

##### Value:

★No reset (DO NOT RESET)	[0]
Reset (RESET COUNTER)	[1]

##### Function:

Reset to zero of parameter 602 *kWh counter*.

##### Description of choice:

If Reset [1] has been selected and when the [OK] key is pressed, the kWh counter of the frequency converter is reset. This parameter cannot be selected via the serial port, RS 485.



##### NB!:

When the [OK] key has been activated, the reset has been carried out.

### 619 Reset of hours-run counter

#### (RESET RUN. HOUR)

##### Value:

★No reset (DO NOT RESET)	[0]
Reset (RESET COUNTER)	[1]

##### Function:

Reset to zero of parameter 601 *Hours-run*.

##### Description of choice:

If Reset [1] has been selected and when the [OK] key is pressed, parameter 601 *Hours-run* is reset. This parameter cannot be selected via the serial port, RS 485.



##### NB!:

When the [OK] key has been activated, the reset has been carried out.

### 620 Operating mode

#### (OPERATION MODE)

##### Value:

★Normal function (NORMAL OPERATION)	[0]
Function with de-activated inverter (OPER. W/INVERT.DISAB)	[1]
Control card test (CONTROL CARD TEST)	[2]
Initialisation (INITIALIZE)	[3]

★ = factory setting. () = display text [] = value for use in communication via serial communication port

### Function:

In addition to its normal function, this parameter can be used for two different tests.

Furthermore, it is possible to reset to the default factory settings for all Setups, except parameters 500 *Address*, 501 *Baud rate*, 600-605 *Operating data* and 615-617 *Fault log*.

### Description of choice:

*Normal function* [0] is used for normal operation of the motor.

Function with *de-activated inverter* [1] is selected if control is desired over the influence of the control signal on the control card and its functions - without the motor shaft running.

*Control card* [2] is selected if control of the analogue and digital inputs, analogue and digital outputs, relay outputs and the control voltage of +10 V is desired.

A test connector with internal connections is required for this test.

The test connector for the *Control card* [2] is set up as follows:

- connect 4-16-17-18-19-27-29-32-33;
- connect 5-12;
- connect 39-20-55;
- connect 42 - 60;
- connect 45-53-54.

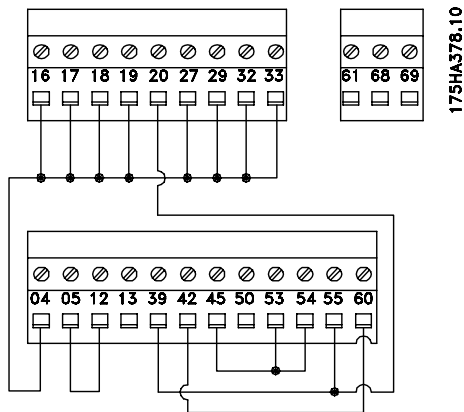

Use the following procedure for the control card test:

1. Select *Control card test*.
2. Cut off the mains supply and wait for the light in the display to go out.
3. Insert the test plug (see preceding column).
4. Connect to mains.
5. The frequency converter expects the [OK] key to be pressed (the test cannot be run without LCP).
6. The frequency converter automatically tests the control card.
7. Remove the test connector and press the [OK] key when the frequency converter displays "TEST COMPLETED".
8. Parameter 620 *Operating mode* is automatically set to *Normal function*.

If the control card test fails, the frequency converter will display "TEST FAILED". Replace the control card.

*Initialisation* [3] is selected if the factory setting of the unit is to be generated without resetting parameters 500 *Address*, 501 *Baud rate*, 600-605 *Operating data* and 615-617 *Fault log*.

Procedure for initialisation:

1. Select *Initialisation*.
2. Press the [OK] key.
3. Cut off the mains supply and wait for the light in the display to go out.
4. Connect to mains.
5. Initialisation of all parameters will be carried out in all Setups with the exception of parameters 500 *Address*, 501 *Baud rate*, 600-605 *Operating data* and 615-617 *Fault log*.

Manual initialisation is another option. (See *Manual initialisation*).

### 655 Fault log: Real time

#### (F. LOG REAL TIME)

#### Value:

[Index 1-10] Value: 000000.0000 - 991231.2359

#### Function:

This parameter has a similar function as parameter 616. Only here the log is based on the real time clock, not running hours from zero. This means a date and time are shown.

★ = factory setting. () = display text [] = value for use in communication via serial communication port

**621 - 631 Nameplate**

Value:

Parameter	Description	Display text
No.	Nameplate	
621	Unit type	(DRIVE TYPE)
622	Power component	(POWER SECTION)
623	VLT ordering no.	(ORDERING NO)
624	Software version no.	(SOFTWARE VERSION)
625	LCP identification no.	(LCP ID NO.)
626	Database identification no.	(PARAM DB ID)
627	Power component identification no.	(POWER UNIT DB ID)
628	Application option type	(APPLIC. OPTION)
629	Application option ordering no.	(APPLIC. ORDER NO)
630	Communication option type	(COM. OPTION)
631	Communication option ordering no.	(COM. ORDER NO)

**Function:**

The main data for the unit can be read from parameters 621 to 631 *Nameplate* via the display or the serial communication port.

**Description of choice:**

**Parameter 621 Nameplate: Unit type:** VLT type gives the unit size and mains voltage.  
Example: VLT 6008 380-460 V.

**Parameter 622 Nameplate: Power component:**

This gives the type of power card fitted to the frequency converter. Example: STANDARD.

**Parameter 623 Nameplate: VLT ordering no.:**

This gives the ordering number for the VLT type in question. Example: 1757805.

**Parameter 624 Nameplate: Software version**

**no.:** This gives the present software version number of the unit. Example: V 1.00.

**Parameter 625 Nameplate: LCP identification**

**no.:** This gives the identification number of the LCP of the unit. Example: ID 1.42 2 kB.

**Parameter 626 Nameplate: Database identification**

**no.:** This gives the identification number of the software's database. Example: ID 1.14.

**Parameter 627 Nameplate: Power component:**

**identification no.:** This gives the identification number of the database of the unit. Example: ID 1.15.

**Parameter 628 Nameplate: Application option**

**type:** This gives the type of application options fitted with the frequency converter.

**Parameter 629 Application option Nameplate:**

**ordering no.:** This gives the ordering number for the application option.

**Parameter 630 Nameplate: Communication option type:** This gives the type of communication options fitted with the T frequency converter.

**Parameter 631 Nameplate: Communication option ordering no.:** This gives the ordering number for the communication option.

---

★ = factory setting. () = display text [] = value for use in communication via serial communication port



**NB!:**

Parameters 700-711 for the relay card are only activated if a relay option card is installed in the VLT 6000 HVAC.

- 700 Relay 6, function**  
**(RELAY6 FUNCTION)**
- 703 Relay 7, function**  
**(RELAY 7 FUNCTION)**
- 706 Relay 8, function**  
**(RELAY8 FUNCTION)**
- 709 Relay 9, function**  
**(RELAY9 FUNCTION)**

**Function:**

This output activates a relay switch. Relay outputs 6/7/8/9 can be used for showing status and warnings. The relay is activated when the conditions for the relevant data values have been fulfilled. Activation/deactivation can be programmed in parameters 701/704/707/710 Relay 6/7/8/9, ON delay and parameters 702/705/708/711 Relay 6/7/8/ 9, OFF delay.

**Description of choice:**

See data choice and connections in *Relay outputs* .

- 701 Relay 6, ON delay**  
**(RELAY6 ON DELAY)**
- 704 Relay 7, ON delay**  
**(RELAY7 ON DELAY)**
- 707 Relay 8, ON delay**  
**(RELAY8 ON DELAY)**
- 710 Relay 9, ON delay**  
**(RELAY9 ON DELAY)**

**Value:**  
0 - 600 sec. ★ 0 sec.

**Function:**

This parameter allows a delay of the cut-in time of relays 6/7/8/9 (terminals 1-2).

**Description of choice:**

Enter the required value.

- 702 Relay 6, OFF delay**  
**(RELAY6 OFF DELAY)**
- 705 Relay 7, OFF delay**  
**(RELAY7 OFF DELAY)**
- 708 Relay 8, OFF delay**  
**(RELAY8 OFF DELAY)**
- 711 Relay 9, OFF delay**  
**(RELAY9 OFF DELAY)**

**Value:**  
0 - 600 sec. ★ 0 sec.

**Function:**

This parameter is used to delay the cut-out time of relays 6/7/8/9 (terminals 1-2).

**Description of choice:**

Enter the required value.

**Electrical installation of the relay card**

The relays are connected as shown below.

Relay 6-9:  
A-B make, A-C break  
Max. 240 V AC, 2 Amp.  
Max. cross-section: 1.5mm<sup>2</sup> (AWG 28-16).  
Torque: 0.22 - 0.25 Nm.  
Screw size: M2.

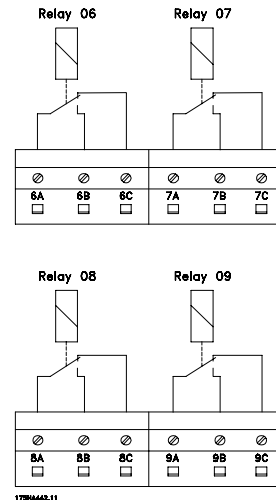

To achieve double isolation, the plastic foil must be mounted as shown in the drawing below.

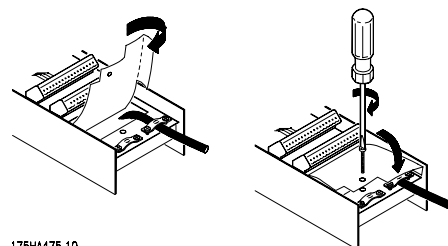

175HA475.10

★ = factory setting. () = display text [] = value for use in communication via serial communication port

### ■ Description of Real Time Clock



#### NB!:

Please note the following parameters are only displayed if the real time clock option is fitted!

The real time clock can show the current time and date and weekday. The available digits stipulate how comprehensive the readout can be.

Further more the RTC is used to execute events based on time. A total of 20 events can be programmed. Firstly the current time and date must be programmed in parameter 780 and 781, please see description of parameters. It is important that both parameters are set. Then parameter 782 through 786 and 789 are used to program the events. First set the week-day(s) in parameter 782 when the action shall take place. Then set the specific time in parameter 783 for the action, then the action itself in parameter 784. In parameter 785 set the time for the termination of the action and in parameter 786 the off-action. Please note the on action and off action must be related. E.g. it is not possible to change setup via the on-action in parameter 784 and then stop drive in parameter 786. The following selection refers to the choices in parameter 784 and 786. Hence selection [1] to [4] are related, [5] to [8] are related, [9] to [12] are related, [13] to [16] are related and finally [17] and [18] are related.

* NO ACTION DEFINED	[0]
SETUP 1	[1]
SETUP 2	[2]
SETUP 3	[3]
SETUP 4	[4]
PRESET REF. 1	[5]
PRESET REF. 2	[6]
PRESET REF. 3	[7]
PRESET REF. 4	[8]
AO42 OFF	[9]
OA42 ON	[10]
AO45 OFF	[11]
AO45 ON	[12]
RELAY 1 ON	[13]
RELAY 1 OFF	[14]
RELAY 2 ON	[15]
RELAY 2 OFF	[16]
START DRIVE	[17]
STOP DRIVE	[18]

It can be chosen if an action, on start-up, shall be executed even if the ON time has been passed some time ago. Alternatively choose to wait for the next forthcoming ON action time before executing the next coming action. This is programmed in parameter 789. It is, however, possible to have several RTC actions within the same period. E.g. relay 1 ON is

executed in the first event at 10:00 and relay 2 ON is executed in the second event at 10:02, before the first event is terminated. Parameter 655 will show the fault log with the RTC, this parameter is directly related to parameter 616. Only here the log is based on the real time clock, not running hours from zero. This means a date and time is shown.

#### 780 Set clock

##### (SET CLOCK)

#### Value:

000000.0000 - 991231.2359      ★ 000000.0000

#### Function:

The time and date is set and displayed in this parameter.

#### Description of choice:

Enter the current date and time to start the clock as follows: YYMMDD.HHMM

Remember to also set parameter 781.

#### 781 Set weekday

##### (SET WEEK DAY)

#### Value:

★MONDAY	[1]
TUESDAY	[1]
WEDNESDAY	[3]
THURSDAY	[4]
FRIDAY	[5]
SATURDAY	[6]
SUNDAY	[7]

#### Function:

The week day is set and displayed in this parameter.

#### Description of choice:

Enter the week day to start the clock in conjunction with parameter 780.

#### 782 Weekdays

##### (WEEKDAYS)

#### Value:

★OFF	[0]
MONDAY	[1]
TUESDAY	[1]
WEDNESDAY	[3]
THURSDAY	[4]
FRIDAY	[5]
SATURDAY	[6]
SUNDAY	[7]
ANY DAY	[8]

★ = factory setting. () = display text [] = value for use in communication via serial communication port



MONDAY TO FRIDAY	[9]
SAT. AND SUNDAY	[10]
MONDAY TO THURS.	[11]
FRIDAY TO SUNDAY	[12]
SUNDAY TO FRIDAY	[13]

### Function:

Set the weekday for specific actions to be executed.

### Description of choice:

The selection of weekday is used to determine the weekday an action must be executed.

### 783 ON clock (ON CLOCK)

#### Value:

[Index 00 - 20] 00.00 - 23.59 ★ 00.00

### Function:

The ON Clock entry defines at which time of the day the corresponding ON Action will take place.

### Description of choice:

Enter the time at which the ON action should take place.

### 784 ON action (ON ACTION)

#### Value:

★NO ACTION DEFINED	[0]
SETUP 1	[1]
SETUP 2	[2]
SETUP 3	[3]
SETUP 4	[4]
PRESET REF. 1	[5]
PRESET REF. 2	[6]
PRESET REF. 3	[7]
PRESET REF. 4	[8]
AO42 OFF	[9]
AO42 ON	[10]
AO45 OFF	[11]
AO45 ON	[12]
RELAY 1 ON	[13]
RELAY 1 OFF	[14]
RELAY 2 ON	[15]
RELAY 2 OFF	[16]
START DRIVE	[17]
STOP DRIVE	[18]

### Function:

An action to be executed is selected here.

### Description of choice:

When the time in parameter 782 is passed the action in the corresponding index is executed. Setup 1 to 4 [1] – [4] is simply selecting setups. The RTC overrides setup selection via digital inputs and bus input. Preset ref [5] – [8] is selecting preset reference. The RTC overrides preset ref selection via digital inputs and bus input. AO42 and AO45 and Relay 1 and 2 [9] – [16] simply activate or deactivate the outputs. Start drive [17] starts the frequency converter, the command is AND'ed or OR'ed with the digital input commands and the bus command. This, however, depends on the selection in parameter 505. Stop drive [18] just stops the frequency converter again.

### 785 OFF clock (OFF CLOCK)

#### Value:

[Index 00 - 20] 00.00 - 23.59 ★ 00.00

### Function:

The OFF Clock entry defines at which time of the day the corresponding OFF Action will take place.

### Description of choice:

Enter the time at which the OFF action should take place.

### 786 OFF action (OFF ACTION)

#### Value:

★NO ACTION DEFINED	[0]
SETUP 1	[1]
SETUP 2	[2]
SETUP 3	[3]
SETUP 4	[4]
PRESET REF. 1	[5]
PRESET REF. 2	[6]
PRESET REF. 3	[7]
PRESET REF. 4	[8]
AO42 OFF	[9]
AO42 ON	[10]
AO45 OFF	[11]
AO45 ON	[12]
RELAY 1 ON	[13]
RELAY 1 OFF	[14]
RELAY 2 ON	[15]
RELAY 2 OFF	[16]
START DRIVE	[17]

STOP DRIVE [18]

**Function:**

An action to be executed is selected here.

**Description of choice:**

When the time in parameter 784 is passed the action in the corresponding index is executed. To make the function safe it is only possible to execute a command related to parameter 783.

---

**789 RTC startup****(RTC STARTUP)****Value:**

Execute on actions (EXEC. ON ACTIONS) [0]  
★Wait new on action (WAIT NEW ON ACTION) [1]

**Function:**

Decide how the frequency converter shall respond to actions after start-up.

**Description of choice:**

It can be chosen if an action, on startup, shall be executed even if the ON time was passed some time ago [0]. Alternatively choose to wait for the next forthcoming ON action before executing [1]. When the RTC is enabled, it must be defined how this should be done.

---

### ■ Status messages

Status messages appear in the 4th line of the display - see example below.

The left part of the status line indicates the active type of control of the frequency converter.

The centre part of the status line indicates the active reference.

The last part of the status line gives the present status, e.g. "Running", "Stop" or "Stand by".

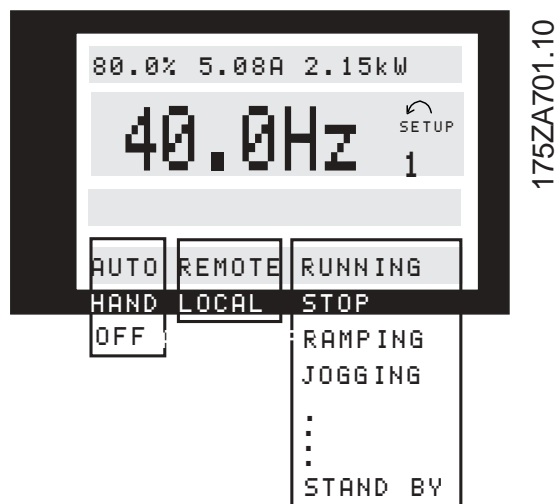

#### Auto mode (AUTO)

The frequency converter is in Auto mode, i.e. control is carried out via the control terminals and/or serial communication. See also *Auto start*.

#### Hand mode (HAND)

The frequency converter is in Hand mode, i.e. control is carried out via the control keys. See *Hand start*.

#### OFF (OFF)

OFF/STOP is activated either by means of the control key, or by the digital inputs *Hand start* and *Auto start* both being a logic "0". See also *OFF/STOP*

#### Local reference (LOCAL)

If LOCAL has been selected, the reference is set via the [+/-] keys on the control panel. See also *Display modes*.

#### Remote reference (REM.)

If REMOTE has been selected, the reference is set via the control terminals or via serial communication. See also *Display modes*.

#### Running (RUNNING)

The motor speed now corresponds to the resulting reference.

#### Ramp operation (RAMPING)

The output frequency is now changed in accordance with the preset ramps.

#### Auto-ramp (AUTO RAMP)

Parameter 208 *Automatic ramp-up/down* is enabled, i.e. the frequency converter is trying to avoid a trip from overvoltage by increasing its output frequency.

#### Sleep Boost (SLEEP.BST)

The boost function in parameter 406 *Boost setpoint* is enabled. This function is only possible in *Closed loop* operation.

#### Sleep mode (SLEEP)

The energy saving function in parameter 403 *Sleep mode timer* is enabled. This means that at present the motor has stopped, but that it will restart automatically when required.

#### Start delay (START DEL)

A start delay time has been programmed in parameter 111 *Start delay*. When the delay has passed, the output frequency will start by ramping up to the reference.

#### Run request (RUN REQ.)

A start command has been given, but the motor will be stopped until a Run permissive signal is received via a digital input.

#### Jogging (JOG)

Jog has been enabled via a digital input or via serial communication.

#### Jog request (JOG REQ.)

A JOG command has been given, but the motor will remain stopped until a *Run permissive* signal is received via a digital input.

#### Freeze output (FRZ.OUT.)

Freeze output has been enabled via a digital input.

#### Freeze output request (FRZ.REQ.)

A freeze output command has been given, but the motor will remain stopped until a Run permissive signal is received via a digital input.

#### Reversing and start (START F/R)

*Reversing and start* [2] on terminal 19 (parameter 303 *Digital inputs*) and *Start* [1] on terminal 18 (parameter 302 *Digital inputs*) are enabled at the same time. The motor will remain stopped until one of the signals becomes a logic '0'.

**Automatic Motor Adaptation running (AMA RUN)**

Automatic motor adaptation has been enabled in parameter 107 *Automatic Motor Adaptation, AMA*.

**Automatic Motor Adaptation completed (AMA STOP)**

Automatic motor adaptation has been completed. The frequency converter is now ready for operation after the *Reset* signal has been enabled. Please note that the motor will start after the frequency converter has received the *Reset* signal.

**Stand by (STANDBY)**

The frequency converter is able to start the motor when a start command is received.

**Stop (STOP)**

The motor has been stopped via a stop signal from a digital input, [OFF/STOP]-button or serial communication.

**DC stop (DC STOP)**

The DC brake in parameter 114-116 has been enabled.

**DRIVE ready (UN. READY)**

The frequency converter is ready for operation, but terminal 27 is a logic "0" and/or a *Coasting command* has been received via the serial communication.

**Not ready (NOT READY)**

The frequency converter is not ready for operation, because of a trip or because OFF1, OFF2 or OFF3 is a logic '0'.

**Start disabled (START IN.)**

This status will only be displayed if, in parameter 599 *Statemachine, Profidrive* [1] has been selected and OFF2 or OFF3 is a logic '0'.

**Exceptions XXXX (EXCEPTIONS XXXX)**

The microprocessor of the control card has stopped and the frequency converter is out of operation. The cause may be noise on the mains, motor or control cables, leading to a stop of the control card microprocessor. Check for EMC-correct connection of these cables.

**■ List of warnings and alarms**

The table gives the different warnings and alarms and indicates whether the fault locks the frequency converter. After Trip locked, the mains supply must be cut and the fault must be corrected. Reconnect the mains supply and reset the frequency converter before being ready. A Trip can be reset manually in three ways

1. Via the control key [RESET]
2. Via a digital input
3. Via serial communication In addition, an automatic reset may be selected in parameter 400 *Reset function*.

Wherever a cross is placed under both Warning and Alarm, this can mean that a warning precedes the alarm. It can also mean that it is possible to program whether a given fault is to result in a warning or an alarm. This is possible, e.g. in parameter 117 *Motor thermal protection*. After a trip, the motor will be coasting and on the frequency converter alarm and warning will flash. If the fault is removed, only the alarm will flash. After a reset, the frequency converter will be ready to start operation again.

No.	Description	Warning	Alarm	Trip locked
1	10 Volts low (10 VOLT LOW)	x		
2	Live zero fault (LIVE ZERO ERROR)	x	x	
4	Mains imbalance (MAINS IMBALANCE)	x	x	x
5	Voltage warning high (DC LINK VOLTAGE HIGH)	x		
6	Voltage warning low (DC LINK VOLTAGE LOW)	x		
7	Overvoltage (DC LINK OVERVOLT)	x	x	
8	Undervoltage (DC LINK UNDERVOLT)	x	x	
9	Inverter overloaded (INVERTER TIME)	x	x	
10	Motor overloaded (MOTOR TIME)	x	x	
11	Motor thermistor (MOTOR THERMISTOR)	x	x	
12	Current limit (CURRENT LIMIT)	x	x	
13	Overcurrent (OVERCURRENT)	x	x	x
14	Earth fault (EARTH FAULT)		x	x
15	Switch mode fault (SWITCH MODE FAULT)		x	x
16	Short-circuit (CURR.SHORT CIRCUIT)		x	x
17	Serial communication timeout (STD BUSTIMEOUT)	x	x	
18	HPFB bus timeout (HPFB TIMEOUT)	x	x	
19	Fault in EEprom on power card (EE ERROR POWER)	x		
20	Fault in EEprom on control card (EE ERROR CONTROL)	x		
22	Auto-optimisation not OK (AMA FAULT)		x	
29	Heat-sink temperature too high (HEAT SINK OVERTEMP.)		x	
30	Motor phase U missing (MISSING MOT.PHASE U)		x	
31	Motor phase V missing (MISSING MOT.PHASE V)		x	
32	Motor phase W missing (MISSING MOT.PHASE W)		x	
34	HPFB communication fault (HPFB COMM. FAULT)	x	x	
37	Inverter fault (GATE DRIVE FAULT)		x	x
39	Check parameters 104 and 106 (CHECK P.104 & P.106)	x		
40	Check parameters 103 and 105 (CHECK P.103 & P.106)	x		
41	Motor too big (MOTOR TOO BIG)	x		
42	Motor too small (MOTOR TOO SMALL)	x		
60	Safety stop (EXTERNAL FAULT)		x	
61	Output frequency low (FOUT < FLOW)	x		
62	Output frequency high (FOUT > FHIGH)	x		
63	Output current low (I MOTOR < I LOW)	x	x	
64	Output current high (I MOTOR > I HIGH)	x		
65	Feedback low (FEEDBACK < FDB LOW)	x		
66	Feedback high (FEEDBACK > FDB HIGH)	x		
67	Reference low (REF. < REF. LOW)	x		
68	Reference high (REF. > REF. HIGH)	x		
69	Temperature auto derate (TEMP.AUTO DERATE)	x		
80	Fire mode was active (FIRE MODE WAS ACTIVE)	x	x	
81	RTC not ready (RTC NOT READY)	x		
99	Unknown fault (UNKNOWN ALARM)		x	x

All about VLT 6000 HVAC

### ■ Warnings

A warning will flash in line 2, while an explanation is given in line 1.

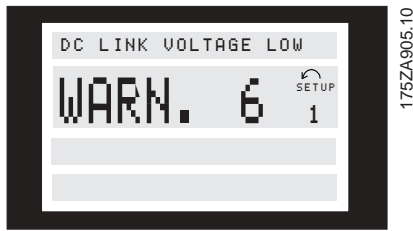

### ■ Alarms

If an alarm is given, the present alarm number will be shown in line 2. Lines 3 and 4 of the display will offer an explanation.



#### WARNING 1

##### Under 10 V (10 VOLT LOW)

The 10 V voltage from terminal 50 on the control card is below 10 V.

Remove some of the load from terminal 50, as the 10 Volts supply is overloaded. Max. 17 mA/min. 590 .

#### WARNING/ALARM 2

##### Live zero fault (LIVE ZERO ERROR)

The current or voltage signal on terminal 53, 54 or 60 is below 50% of the value preset in parameter 309, 312 and 315 *Terminal, min. scaling*.

#### WARNING/ALARM 4

##### Mains imbalance (MAINS IMBALANCE)

High imbalance or phase missing on the supply side. Check the supply voltage to the frequency converter.

#### WARNING 5

##### Voltage warning high (DC LINK VOLTAGE HIGH)

The intermediate circuit voltage (DC) is higher than *Voltage warning high*, see table below. The controls of the frequency converter are still enabled.

#### WARNING 6

##### Voltage warning low (DC LINK VOLTAGE LOW)

The intermediate circuit voltage (DC) is lower than *Voltage warning low*, see table below. The controls of the frequency converter are still enabled.

#### WARNING/ALARM 7

##### Overvoltage (DC LINK OVERVOLT)

If the intermediate circuit voltage (DC) is higher than the *Overvoltage limit* of the inverter (see table below), the frequency converter will trip after a fixed period. The length of this period depends on the unit.

Alarm/warning limits:

VLT 6000 HVAC	3 x 200 - 240 V	3 x 380 - 460 V	3 x 525-600 V	3 x 525-600 V <sup>1)</sup>
	[VDC]	[VDC]	[VDC]	[VDC]
Undervoltage	211	402	557	553
Voltage warning low	222	423	585	585
Voltage warning high	384	769	943	1084
Overvoltage	425	855	975	1130

1) VLT 6102-6652.

The voltages stated are the intermediate circuit voltage of the frequency converter with a tolerance of  $\pm 5\%$ . The corresponding mains voltage is the intermediate circuit voltage divided by 1,35.

**Warnings and alarms, cont.**
**WARNING/ALARM 8**
**Undervoltage (DC LINK UNDERVOLT)**

If the intermediate circuit voltage (DC) drops below the *undervoltage limit* of the inverter, the frequency converter will trip after a fixed period, the length of the period depending on the unit. Furthermore, the voltage will be stated in the display. Check whether the supply voltage matches the frequency converter, see *Technical data*.

**WARNING/ALARM 9**
**Inverter overload (INVERTER TIME)**

The electronic, thermal inverter protection reports that the frequency converter is about to cut out because of an overload (too high current for too long). The counter for electronic, thermal inverter protection gives a warning at 98% and trips at 100%, while giving an alarm. The frequency converter cannot be reset until the counter is below 90%. The fault is that the frequency converter is overloaded by more than 100% for too long.

**WARNING/ALARM 10**
**Motor overtemperature (MOTOR TIME)**

According to the electronic thermal protection (ETR), the motor is too hot. Parameter 117 *Motor thermal protection* allows a choice of whether the frequency converter is to give a warning or an alarm when the *Motor thermal projection* reaches 100%. The fault is that the motor is overloaded by more than 100% of the preset, rated motor current for too long. Check that the motor parameters 102-106 have been set correctly.

**WARNING/ALARM 11**
**Motor thermistor (MOTOR THERMISTOR)**

The thermistor or the thermistor connection has been disconnected. Parameter 117 *Motor thermal protection* allows a choice of whether the frequency converter is to give a warning or an alarm. Check that the thermistor has been correctly connected between terminal 53 or 54 (analogue voltage input) and terminal 50 (+ 10 V supply).

**WARNING/ALARM 12**
**Current limit (CURRENT LIMIT)**

The current is higher than the value in parameter 215 *Current limit*  $I_{LIM}$  and the frequency converter trips after the time set in parameter 412 *Trip delay overcurrent* ,  $I_{LIM}$  has passed.

**WARNING/ALARM 13**
**Overcurrent (OVER CURRENT)**

The inverter peak current limit (approx. 200% of the rated current) has been exceeded. The warning will last approx. 1-2 seconds, following which the frequency converter will trip and give off an alarm. Turn off the frequency converter and check whether the motor shaft can be turned and whether the motor size matches the frequency converter.

**ALARM: 14**
**Earth fault (EARTH FAULT)**

There is a discharge from the output phases to earth, either in the cable between the frequency converter and the motor or in the motor itself. Turn off the frequency converter and remove the earth fault.

**ALARM: 15**
**Switch mode fault (SWITCH MODE FAULT)**

Fault in the switch mode power supply (internal  $\pm 15$  V supply). Contact your Danfoss supplier.

**ALARM: 16**
**Short-circuiting (CURR. SHORT CIRCUIT)**

There is short-circuiting on the motor terminals or in the motor itself. Cut off the mains supply to the frequency converter and remove the short-circuit.

**WARNING/ALARM 17**
**Serial communication timeout (STD BUSTIMEOUT)**

There is no serial communication with the frequency converter.

This warning will only be enabled if parameter 556 *Bus time interval function* has been set to a value different from OFF.

If parameter 556 *Bus time interval function* has been set to *Stop and trip* [5], the frequency converter will first give off an alarm, then ramp down and finally trip while giving off an alarm. It is possible to increase parameter 555 *Bus time interval* .

**Warnings and alarms, cont.**
**WARNING/ALARM 18**
**HPFB bus timeout (HPFB TIMEOUT)**

There is no serial communication with the communication option card of the frequency converter. The warning will only be enabled if parameter 804 *Bus time interval function* has been set to anything but OFF. If parameter 804 *Bus time interval function* has been set to *Stop and trip*, the frequency converter

will first give off an alarm, then ramp down and finally trip while giving off an alarm.

Parameter 803 *Bus time interval* could possibly be increased.

**WARNING 19**

**Fault in the EEPROM on the power card (EE ERROR POWER)** There is a fault on the power card EEPROM. The frequency converter will continue to function, but is likely to fail at the next power-up. Contact your Danfoss supplier.

**WARNING 20**

**Fault in the EEPROM on the control card (EE ERROR CONTROL)** There is a fault in the EEPROM on the control card. The frequency converter will continue to function, but is likely to fail at the next power-up. Contact your Danfoss supplier.

**ALARM: 22**

**Auto-optimisation not OK (AMA FAULT)** A fault has been found during automatic motor adaptation. The text shown in the display indicates a fault message.



**NB!:**

AMA can only be carried out if there are no alarms during tuning.

**CHECK 103, 105 [0]**

Parameter 103 or 105 has a wrong setting. Correct the setting and start AMA all over.

**LOW P.105 [1]**

The motor is too small for AMA to be carried out. If AMA is to be enabled, the rated motor current (parameter 105) must be higher than 35% of the rated out-put current of the frequency converter.

**ASYMMETRICAL IMPEDANCE [2]**

AMA has detected an asymmetrical impedance in the motor connected to the system. The motor could be defective.

**MOTOR TOO BIG [3]**

The motor connected to the system is too big for AMA to be carried out. The setting in parameter 102 does not match the motor used.

**MOTOR TOO SMALL [4]**

The motor connected to the system is too small for AMA to be carried out. The setting in parameter 102 does not match the motor used.

**TIME OUT [5]**

AMA fails because of noisy measuring signals. Try to start AMA all over a number of times, until AMA is carried out. Please note that repeated AMA runs may

heat the motor to a level where the stator resistance  $R_s$  is increased. In most cases, however, this is not critical.

**INTERRUPTED BY USER [6]**

AMA has been interrupted by the user.

**INTERNAL FAULT [7]**

An internal fault has occurred in the frequency converter. Contact your Danfoss supplier.

**LIMIT VALUE FAULT [8]**

The parameter values found for the motor are outside the acceptable range within which the frequency converter is able to work.

**MOTOR ROTATES [9]**

The motor shaft rotates. Make sure that the load is not able to make the motor shaft rotate. Then start AMA all over.

**Warnings and alarms, cont.**

**ALARM 29**

**Heat sink temperature too high (HEAT SINK OVER TEMP.):**

If the enclosure is IP 00, IP 20 or NEMA 1, the cut-out temperature of the heat-sink is 90°C. If IP 54 is used, the cut-out temperature is 80°C. The tolerance is  $\pm 5^\circ\text{C}$ . The temperature fault cannot be reset, until the temperature of the heat-sink is below 60°C.

The fault could be the following:

- Ambient temperature too high
- Too long motor cable
- Too high switching frequency.

**ALARM: 30**

**Motor phase U missing (MISSING MOT.PHASE U):**

Motor phase U between frequency converter and motor is missing.

Turn off the frequency converter and check motor phase U.

**ALARM: 31**

**Motor phase V missing (MISSING MOT.PHASE V):**

Motor phase V between frequency converter and motor is missing.

Turn off the frequency converter and check motor phase V.



**ALARM: 32**
**Motor phase W missing  
(MISSING MOT.PHASE U):**

Motor phase W between frequency converter and motor is missing.

Turn off the frequency converter and check motor phase W.

**WARNING/ALARM: 34**
**HPFB communication fault  
(HPFB COMM. FAULT)**

The serial communication on the communication option card is not working.

**ALARM: 37**
**Inverter fault (GATE DRIVE FAULT):**

IGBT or the power card is defective. Contact your Danfoss supplier.

**Auto-optimisation warnings 39-42**

Automatic motor adaptation has stopped, since some parameters have probably been set wrongly, or the motor used is too big/small for AMA to be carried out. A choice must thus be made by pressing [CHANGE DATA] and choosing 'Continue' + [OK] or 'Stop' + [OK]. If parameters need to be changed, select 'Stop'; start up AMA all over.

**WARNING: 39**
**CHECK PAR. 104, 106**

Parameters 104 *Motor frequency*  $f_{M,N}$ , or 106 *Rated motor speed*  $n_{M,N}$ , have probably not been set correctly. Check the setting and select 'Continue' or [STOP].

**WARNING: 40**
**CHECK PAR. 103, 105**

Parameter 103 *Motor voltage*,  $U_{M,N}$  or 105 *Motor current*,  $I_{M,N}$  has not been set correctly. Correct the setting and restart AMA.

**WARNING: 41**
**MOTOR TOO BIG (MOTOR TOO BIG)**

The motor used is probably too big for AMA to be carried out. The setting in parameter 102 *Motor power*,  $P_{M,N}$  may not match the motor. Check the motor and choose 'Continue' or [STOP].

**WARNING: 42**
**MOTOR TOO SMALL (MOTOR TOO SMALL)**

The motor used is probably too small for AMA to be carried out. The setting in parameter 102 *Motor power*,  $P_{M,N}$  may not match the motor. Check the motor and select 'Continue' or [STOP].

**ALARM: 60**
**Safety stop (EXTERNAL FAULT)**

Terminal 27 (parameter 304 Digital inputs) has been programmed for a *Safety interlock* [3] and is a logic '0'.

**WARNING: 61**
**Output frequency low (FOUT < FLOW)**

The output frequency is lower than parameter 223  
*Warning: Low frequency,  $f_{LOW}$ .*

**WARNING: 62**
**Output frequency high (FOUT > FHIGH)**

The output frequency is higher than parameter 224  
*Warning: High frequency,  $f_{HIGH}$ .*

**WARNING/ALARM: 63**
**Output current low (I MOTOR < I LOW)**

The output current is lower than parameter 221  
*Warning: Low current,  $I_{LOW}$ .* Select the required function in parameter 409 *Function in case of no load*.

**WARNING: 64**
**Output current high (I MOTOR > I HIGH)**

The output current is higher than parameter 222  
*Warning: High current,  $I_{HIGH}$ .*

**WARNING: 65**
**Feedback low (FEEDBACK < FDB LOW)**

The resulting feedback value is lower than parameter 227  
*Warning: Low feedback,  $FB_{LOW}$ .*

**WARNING: 66**
**Feedback high (FEEDBACK > FDB HIGH)**

The resulting feedback value is higher than parameter 228  
*Warning: High feedback,  $FB_{HIGH}$ .*

**WARNING: 67**
**Remote reference low (REF. < REF LOW)**

The remote reference is lower than parameter 225  
*Warning: Low reference,  $REF_{LOW}$ .*

**WARNING: 68**
**Remote reference high (REF. > REF HIGH)**

The remote reference is higher than parameter 226  
*Warning: High reference,  $REF_{HIGH}$ .*

**WARNING: 69**
**Temperature auto derate (TEMP.AUTO DERATE)**

The heat sink temperature has exceeded the maximum value and the auto derating function (par. 411) is active.  
*Warning: Temp. Auto derate.*

**WARNING/ALARM: 80****Fire Mode was active (FIRE MODE WAS ACTIVE)**

Fire Mode has been activated via terminal 16 or 17. If the warning is shown after a power cycle please contact your Danfoss supplier.

**WARNING: 81****RTC not ready (RTC NOT READY)**

The frequency converter has been de-energized for more than approx. 4 days or the frequency converter was not on for 24 hours first time to charge the back-up. As soon as a user re-programme the time and week day this warning is dismissed

**WARNING: 99****Unknown fault (UNKNOWN ALARM)**

An unknown fault has occurred which the software is not able to handle.  
Contact your Danfoss supplier.

### ■ Aggressive environments

In common with all electronic equipment, a frequency converter contains a large number of mechanical and electronic components, all of which are vulnerable to environmental effects to some extent.



The frequency converter should not therefore be installed in environments with airborne liquids, particles or gases capable of affecting and damaging the electronic components. Failure to take the necessary protective measures increases the risk of stoppages, thus reducing the life of the frequency converter.

Liquids can be carried through the air and condense in the frequency converter. In addition to this, liquids may cause corrosion of components and metal parts. Steam, oil and salt water may cause corrosion of components and metal parts. In such environments, equipment with enclosure rating IP 54 is recommended.

Airborne particles such as dust particles may cause mechanical, electrical or thermal failure in the frequency converter.

A typical indicator of excessive levels of airborne particles is dust particles around the frequency converter fan.

In very dusty environments, equipment with enclosure rating IP 54 or a cabinet for IP 00/20 equipment is recommended.

In environments with high temperatures and humidity, corrosive gases such as sulphur, nitrogen and chlorine compounds will cause chemical processes on the frequency converter components. Such chemical reactions will rapidly affect and damage the electronic components.

In such environments, it is recommended that equipment is mounted in a cabinet with fresh air ventilation, keeping aggressive gases away from the frequency converter.



#### NB!:

Mounting frequency converters in aggressive environments will increase the risk of stop-pages and furthermore considerably reduce the life of the converter.

Before the installation of the frequency converter, the ambient air should be checked for liquids, particles and gases. This may be done by observing existing installations in this environment. Typical indicators of

harmful airborne liquids are water or oil on metal parts, or corrosion of metal parts.

Excessive dust particle levels are often found on installation cabinets and existing electrical installations. One indicator of aggressive airborne gases is blackening of copper rails and cable ends on existing installations.

### ■ Calculation of resulting reference

The calculation made below gives the resulting reference when parameter 210 *Reference type* is programmed for Sum [0] and Relative [1], respectively.

External reference can be calculated as follows:

$$\text{Ext. ref.} = \frac{(\text{Par. 205 Max. ref.} - \text{Par. 204 Min. ref.}) \times \text{Ana. signal Term. 53 [V]} + (\text{Par. 205 Max. ref.} - \text{Par. 204 Min. ref.}) \times \text{Par. 314 Term. 60 [mA]}}{\text{Par. 310 Term. 53 Max. scaling} - \text{Par. 309 Term. 53 Min. scaling} + \text{Par. 316 Term. 60 Max. scaling} - \text{Par. 315 Term. 60 Min. scaling}} + \frac{(\text{Par. 205 Max. ref.} - \text{Par. 204 Min. ref.}) \times \text{Ana. signal Term. 54 [V]} + \text{serial com. reference} \times (\text{Par. 205 Max. ref.} - \text{Par. 204 Min. ref.})}{\text{Par. 313 Term. 54 Max. scaling} - \text{Par. 312 Term. 54 Min. scaling} + 16384 (4000 \text{ Hex})} +$$

Par. 210 Reference type is programmed = Sum [0].

$$\text{Ext. ref.} = \frac{(\text{Par. 205 Max. ref.} - \text{Par. 204 Min. ref.}) \times \text{Par. 211-214 Preset ref.}}{100} + \frac{\text{External ref.} + \text{Par. 204 Min. ref.} + \text{Par. 418/419 Setpoint (only in closed loop)}}{100}$$

Par. 210 Reference type is programmed = Relative [1].

$$\text{Res. ref.} = \frac{\text{External reference} \times \text{Par. 211-214 Preset ref.}}{100} + \text{Par. 204 Min. ref.} + \text{Par. 418/419 Setpoint (only in closed loop)}$$

External reference is the sum of references from terminals 53, 54, 60 and serial communication. The sum of these can never exceed parameter 205 *Max. reference*.

■ Galvanic isolation (PELV)

PELV offers protection by way of extra low voltage. Protection against electric shock is considered to be ensured when the electrical supply is of the PELV type and the installation is made as described in local/national regulations on PELV supplies.

In VLT 6000 HVAC all control terminals as well as terminals 1-3 (AUX relay) are supplied from or in connection with extra low voltage (PELV).

Galvanic (ensured) isolation is obtained by fulfilling requirements concerning higher isolation and by providing the relevant creepage/clearance distances. These requirements are described in the EN 50178 standard.

For additional information on PELV see *RFI switching*.

Galvanic isolation

The components that make up the electrical isolation, as described below, also comply with the requirements concerning higher isolation and the relevant test as described in EN 50178.

The galvanic isolation can be shown in three locations (see drawing below), namely:

- Power supply (SMPS) incl. signal isolation of  $U_{DC}$ , indicating the intermediate current voltage.
- Gate drive that runs the IGBTs (trigger transformers/opto-couplers).
- Current transducers (Hall effect current transducers).

NOTE: VLT 6002-6072, 525-600 V units do not meet PELV requirements in accordance with EN 50178.

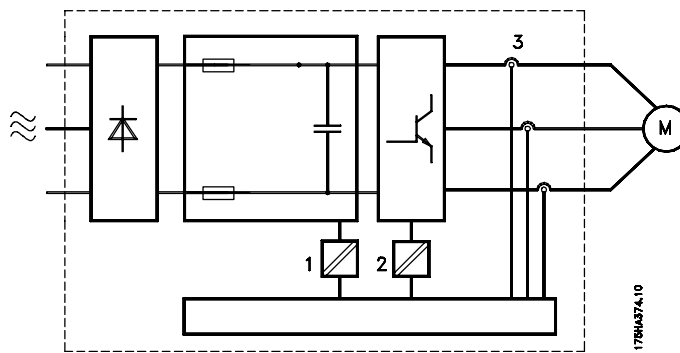

■ Earth leakage current

Earth leakage current is primarily caused by the capacitance between motor phases and the motor cable screen. When an RFI filter is used, this contributes additional leakage current, as the filter circuit is connected to earth through capacitors.

See drawing on the following page.

The size of the leakage current to the ground depends on the following factors, in order of priority:

1. Length of motor cable
2. Motor cable with or without screen
3. Switching frequency
4. RFI filter used or not
5. Motor grounded on site or not.

The leakage current is of importance to safety during handling/operation of the frequency converter if (by mistake) the frequency converter has not been earthed.



**NBI:**

Since the leakage current is > 3.5 mA, rein-forced earthing must be established, which is required if EN 50178 is to be complied with.

Never use ELCB relays (type A) that are not suitable for DC fault currents from three-phase rectifier loads.

If ELCB relays are used, they must be:

- Suitable for protecting equipment with a direct current content (DC) in the fault current (3-phase bridge rectifier)
- Suitable for power-up with short pulse-shaped charging current to earth
- Suitable for a high leakage current (300 mA).

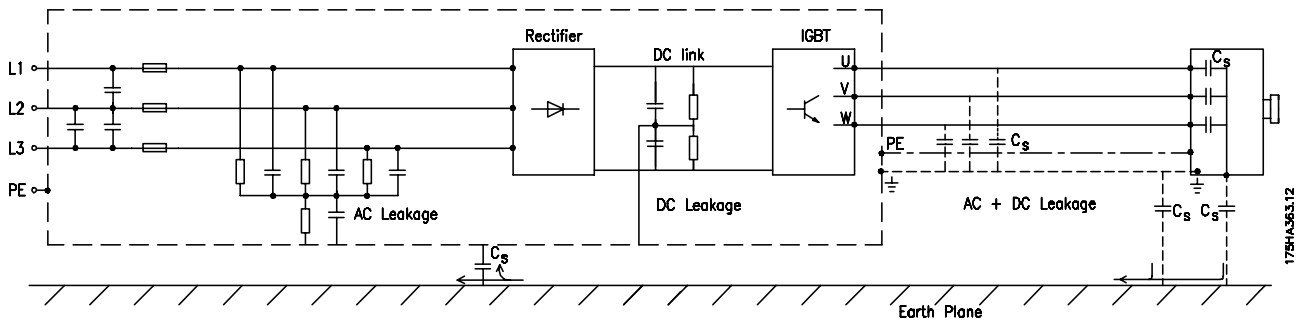

### ■ Extreme running conditions

#### Short circuit

VLT 6000 HVAC is protected against short circuits by means of current measurement in each of the three motor phases. A short circuit between two output phases will cause an overcurrent in the inverter. However, each transistor of the inverter will be turned off individually when the short circuit current exceeds the permitted value.

After a few microseconds the driver card turns off the inverter and the frequency converter will display a fault code, although depending on impedance and motor frequency.

#### Earth fault

The inverter cuts out within a few microseconds in case of an earth fault on a motor phase, although depending on impedance and motor frequency.

#### Switching on the output

Switching on the output between the motor and the frequency converter is fully permitted. It is not possible to damage VLT 6000 HVAC in any way by switching on the output. However, fault messages may appear.

#### Motor-generated overvoltage

The voltage in the intermediate circuit is increased when the motor acts as a generator. This occurs in two cases:

1. The load drives the motor (at constant output frequency from the frequency converter), i.e. the load generates energy.
2. During deceleration ("ramp-down") if the moment of inertia is high, the load is low and the ramp-down time is too short for the energy to be dissipated as a loss in the frequency converter, the motor and the installation.

The control unit attempts to correct the ramp if possible. The inverter turns off to protect the transistors and the intermediate circuit capacitors when a certain voltage level is reached.

#### Mains drop-out

During a mains drop-out, VLT 6000 HVAC continues until the intermediate circuit voltage drops below the minimum stop level, which is typically 15% below VLT 6000 HVAC's lowest rated supply voltage.

The time before the inverter stops depends on the mains voltage before the drop-out and on the motor load.

#### Static overload

When VLT 6000 HVAC is overloaded (the current limit in parameter 215 *Current limit*,  $I_{LM}$  has been reached), the controls will reduce the output frequency in an attempt to reduce the load.

If the overload is excessive, a current may occur that makes the frequency converter cut out after approx. 1.5 sec.

Operation within the current limit can be limited in time (0-60 s) in parameter 412 *Trip delay overcurrent*,  $I_{LM}$ .

**Peak voltage on motor**

When a transistor in the inverter is opened, the voltage across the motor increases by a  $dV/dt$  ratio that depends on:

- the motor cable (type, cross-section, length screened or unscreened)
- inductance

The natural induction causes an overshoot  $U_{PEAK}$  in the motor voltage before it stabilises itself at a level which depends on the voltage in the intermediate circuit. The rise time and the peak voltage  $U_{PEAK}$  affect the service life of the motor. If the peak voltage is too high, motors without phase coil insulation are the ones that will primarily be affected. If the motor cable is short (a few metres), the rise time and peak voltage are lower. If the motor cable is long (100 m), the rise time and peak voltage will increase.

If very small motors are used without phase coil insulation, it is recommended to fit a LC filter after the frequency converter. Typical values for the rise time and peak voltage  $U_{PEAK}$  are measured on the motor terminals between two phases.

To obtain approximate values for cable lengths and voltages not mentioned below, use the following rules of thumb:

1. Rise time increases/decreases proportionally with cable length.
2.  $U_{PEAK} = DC \text{ link voltage} \times 1.9$   
(DC link voltage = Mains voltage  $\times 1.35$ ).
3.  $dU/dt = \frac{0.8 \times U_{PEAK}}{\text{Rise time}}$

Data are measured according to IEC 60034-17.

**VLT 6002-6011 / 380-460 V**

Cable length	Mains		Peak	
	volt-age	Rise time	voltage	dU/dt
50 metres	380 V	0.3 $\mu$ sec.	850 V	2000 V/ $\mu$ sec.
50 metres	500 V	0.4 $\mu$ sec.	950 V	2600 V/ $\mu$ sec.
150 metres	380 V	1.2 $\mu$ sec.	1000 V	667 V/ $\mu$ sec.
150 metres	500 V	1.3 $\mu$ sec.	1300 V	800 V/ $\mu$ sec.

**VLT 6016-6122 / 380-460 V**

Cable length	Mains		Peak	
	volt-age	Rise time	voltage	dU/dt
32 metres	380 V	0.27 $\mu$ sec.	950 V	2794 V/ $\mu$ sec.
70 metres	380 V	0.60 $\mu$ sec.	950 V	1267 V/ $\mu$ sec.
132 metres	380 V	1.11 $\mu$ sec.	950 V	685 V/ $\mu$ sec.

**VLT 6152-6352 / 380-460 V**

Cable length	Mains		Peak	
	volt-age	Rise time	voltage	dU/dt
70 metres	400 V	0.34 $\mu$ sec.	1040 V	2447 V/ $\mu$ sec.

**VLT 6402-6602 / 380-460 V**

Cable length	Mains		Peak	
	volt-age	Rise time	voltage	dU/dt
29 metres	500 V	0.71 $\mu$ sec.	1165 V	1389 V/ $\mu$ sec.
29 metres	400 V	0.61 $\mu$ sec.	942 V	1233 V/ $\mu$ sec.

**VLT 6002-6011 / 525-600 V**

Cable length	Mains		Peak	
	volt-age	Rise time	voltage	dU/dt
35 metres	600 V	0.36 $\mu$ sec.	1360 V	3022 V/ $\mu$ sec.

**VLT 6016-6072 / 525-600 V**

Cable length	Mains		Peak	
	volt-age	Rise time	voltage	dU/dt
35 metres	575 V	0.38 $\mu$ sec.	1430 V	3011 V/ $\mu$ sec.

**VLT 6102-6402 / 525-600 V**

Cable length	Mains	Peak		
	voltage	Rise time	voltage	dU/dt
25 metres	575 V	0.45 $\mu$ sec.	1159	1428 V/ $\mu$ sec.

**VLT 6502-6652 / 525-600 V**

Cable length	Mains	Peak		
	voltage	Rise time	voltage	dU/dt
25 metres	575 V	0.25 $\mu$ sec.	1159	2510 V/ $\mu$ sec.

**Switching on the input**

Switching on the input depends on the mains voltage in question.

The table states the waiting time between cut-ins.

Mains voltage	380 V	415 V	460 V
Waiting time	48 s	65 s	89 s

### ■ Acoustic noise

The acoustic interference from the frequency converter comes from two sources:

1. DC intermediate circuit coils
2. Integral fan.

Below are the typical values measured at a distance of 1 m from the unit at full load and are nominal maximum values:

#### VLT 6002-6006 200-240 V, VLT 6002-6011 380-460 V

IP 20 units: 50 dB(A)  
IP 54 units: 62 dB(A)

#### VLT 6008-6027 200-240 V, VLT 6016-6122 380-460 V

IP 20 units: 61 dB(A)  
IP 54 units: 66 dB(A)

#### VLT 6042-6062 200-240 V

IP 00/20 units: 70 dB(A)  
IP 54 units: 65 dB(A)

#### VLT 6152-6352 380-460 V

IP 00/21/NEMA 1/IP 54: 74 dB(A)

#### VLT 6402 380-460 V

All enclosure types: 80 dB(A)

#### VLT 6502-6602 380-460 V

All enclosure types: 83 dB(A)

#### VLT 6002-6011 525-600 V

IP 20/NEMA 1 units: 62 dB(A)

#### VLT 6102-6402 525-600 V

IP 20/NEMA 1 units: 74 dB(A)  
IP 54 units: 74 dB(A)

#### VLT 6502 525-600 V

All units: 80 dB(A)

#### VLT 6602-6652 525-600 V

All units: 83 dB(A)

\* Measured 1 meter from the unit at full load.

### ■ Derating for ambient temperature

The ambient temperature ( $T_{AMB,MAX}$ ) is the maximum temperature allowed. The average ( $T_{AMB,AVG}$ ) measured over 24 hours must be at least 5 °C lower.

If VLT 6000 HVAC is operated at temperatures above 45 °C, a derating of the continuous output current is necessary.

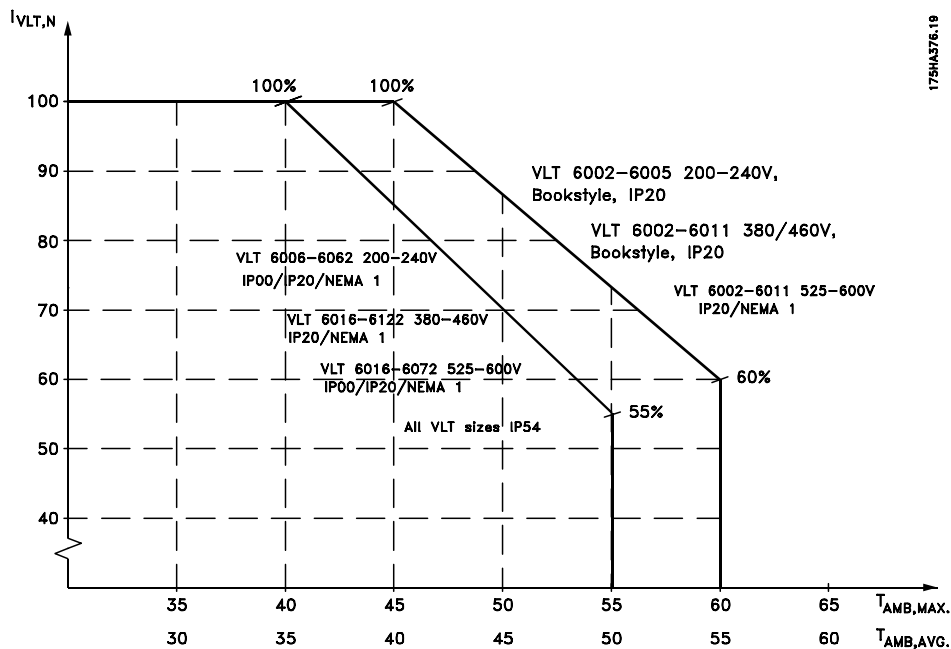

- The current of VLT 6152-6602, 380-460 V and VLT 6102-6402, 525-600 V, is to be derated 1%/°C above 40° C to 55°C maximum.

- The current of VLT 6502-6652, 525-600 V, is to be derated 1.5%/°C above 40° C to 55°C maximum.

### Derating for air pressure

Below 1000 m altitude no derating is necessary.

Above 1000 m the ambient temperature ( $T_{AMB}$ ) or max. output current ( $I_{VLT,MAX}$ ) must be derated in accordance with the diagram below:

1. Derating of output current versus altitude at  $T_{AMB} = \text{max. } 45^{\circ}\text{C}$
2. Derating of max.  $T_{AMB}$  versus altitude at 100% output current.

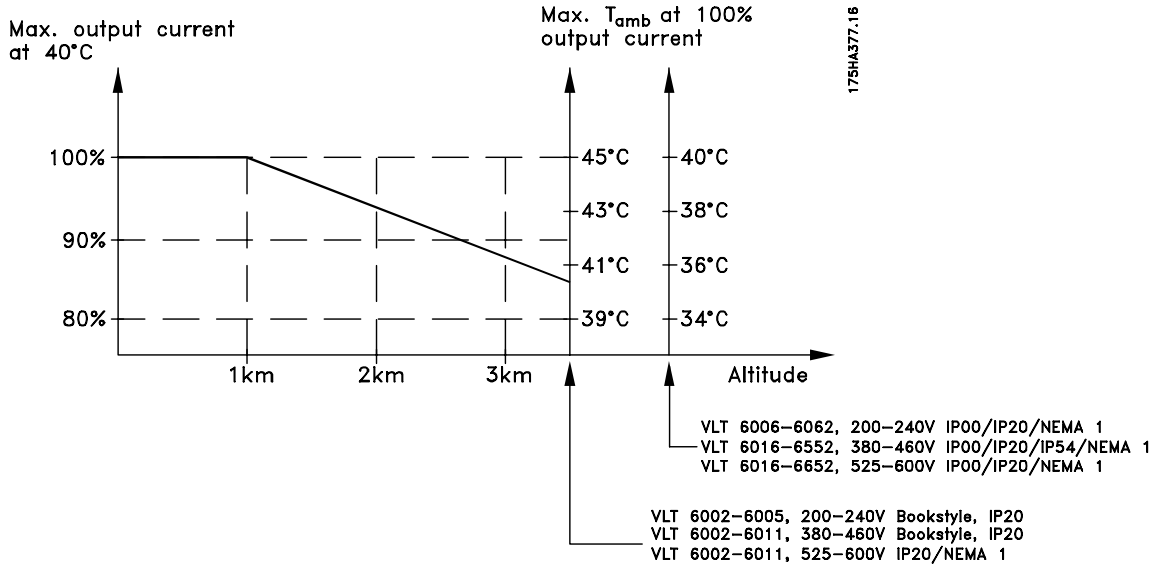

### Derating for running at low speed

When a centrifugal pump or a fan is controlled by a VLT 6000 HVAC frequency converter, it is not necessary to reduce the output current at low speed because the load characteristic of the centrifugal pumps/fans, automatically ensures the necessary reduction.

VLT 6000 HVAC has a pulse pattern in which it is possible to set the switching frequency from 3.0- 10.0/14.0 kHz.

The frequency converter will automatically derate the rated output current  $I_{VLT,N}$ , when the switching frequency exceeds 4.5 kHz.

### Derating for long motor cables or cables with larger cross-section

VLT 6000 HVAC has been tested using 300 m unscreened/unarmoured cable and 150 m screened/armoured cable.

VLT 6000 HVAC has been designed to work using a motor cable with a rated cross-section. If a cable with a larger cross-section is to be used, it is recommended to reduce the output current by 5% for every step the cross-section is increased. (Increased cable cross-section leads to increased capacity to earth, and thus an increased earth leakage current).

In both cases, the reduction is carried out linearly, down to 60% of  $I_{VLT,N}$ .

The table gives the min., max. and factory-set switching frequencies for VLT 6000 HVAC units.

Switching frequency [kHz]	Min.	Max.	Fact.
VLT 6002-6005, 200 V	3.0	10.0	4.5
VLT 6006-6032, 200 V	3.0	14.0	4.5
VLT 6042-6062, 200 V	3.0	4.5	4.5
VLT 6002-6011, 460 V	3.0	10.0	4.5
VLT 6016-6062, 460 V	3.0	14.0	4.5
VLT 6072-6122, 460 V	3.0	4.5	4.5
VLT 6152-6352, 460 V	3.0	4.5	4.5
VLT 6402-6602, 460 V	1.5	3.0	3.0
VLT 6002-6011, 600 V	4.5	7.0	4.5
VLT 6016-6032, 600 V	3.0	14.0	4.5
VLT 6042-6062, 600 V	3.0	10.0	4.5
VLT 6072, 600 V	3.0	4.5	4.5
VLT 6102-6352, 690 V	1.5	2.0	2.0
VLT 6402-6652, 600 V	1.5	1.5	1.5

### Derating for high switching frequency

A higher switching frequency (to be set in parameter 407, *Switching frequency*) leads to higher losses in the electronics of the frequency converter.



■ **Motor thermal protection**

The motor temperature is calculated on the basis of motor current, output frequency and time. See parameter 117, *Motor thermal protection*.

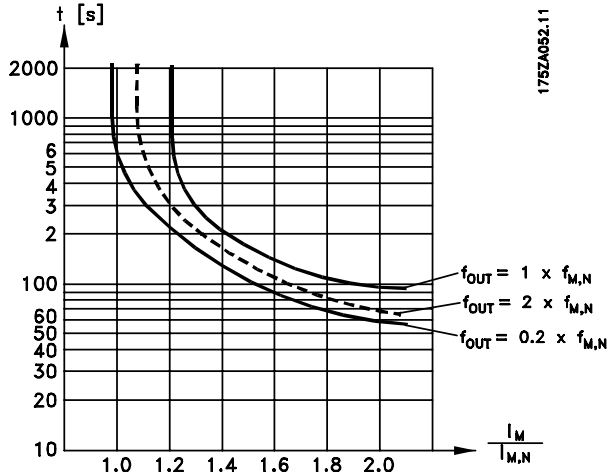

■ **Vibration and shock**

VLT 6000 HVAC has been tested according to a procedure based on the following standards:

- IEC 68-2-6:           Vibration (sinusoidal) - 1970
- IEC 68-2-34:         Random vibration broad-band  
- general requirements
- IEC 68-2-35:         Random vibration broad-band  
- high reproducibility
- IEC 68-2-36:         Random vibration broad-band  
- medium reproducibility

VLT 6000 HVAC complies with requirements that correspond to conditions when the unit is mounted on the walls and floors of production premises, as well as in panels bolted to walls or floors.

■ **Air humidity**

VLT 6000 HVAC has been designed to meet the IEC 68-2-3 standard, EN 50178 pkt. 9.4.2.2/DIN 40040, class E, at 40°C.

See *specifications* under *General technical data*.

All about VLT 6000 HVAC

### ■ Efficiency

To reduce energy consumption it is very important to optimize the efficiency of a system. The efficiency of each single element in the system should be as high as possible.

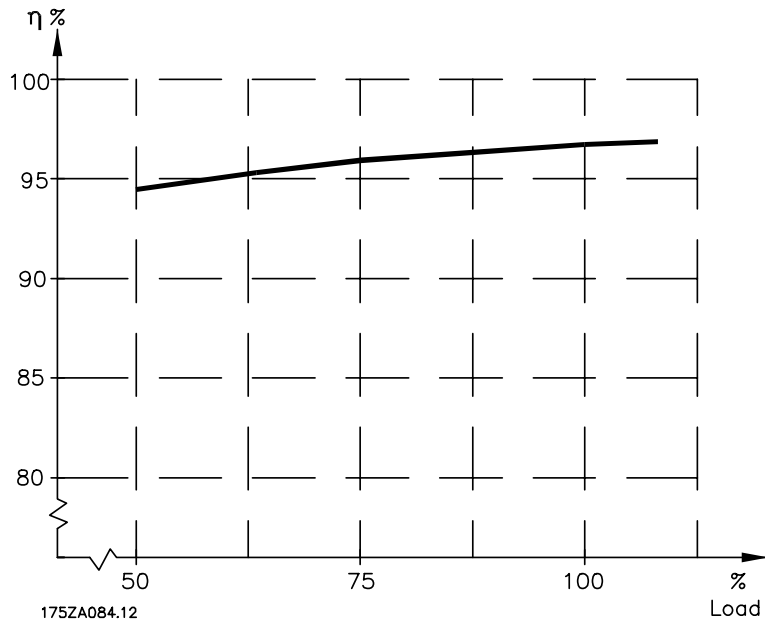

#### Efficiency of VLT 6000 HVAC ( $\eta_{VLT}$ )

The load on the frequency converter has little effect on its efficiency. In general, the efficiency is the same at the rated motor frequency  $f_{M,N}$ , regardless of whether the motor supplies 100% of the rated shaft torque or only 75%, i.e. in case of part loads.

The efficiency declines a little when the switching frequency is set to a value of above 4 kHz (parameter 407 *Switching frequency*). The rate of efficiency will also be slightly reduced if the mains voltage is 460 V, or if the motor cable is longer than 30 m.

#### Efficiency of the motor ( $\eta_{MOTOR}$ )

The efficiency of a motor connected to the frequency converter depends on the sine shape of the current. In general, the efficiency is just as good as with mains operation. The efficiency of the motor depends on the type of motor.

In the range of 75-100% of the rated torque, the efficiency of the motor is practically constant, both when it is controlled by the frequency converter and when it runs directly on mains.

In small motors, the influence from the U/f characteristic on efficiency is marginal; however, in motors from 11 kW and up, the advantages are significant.

In general, the switching frequency does not affect the efficiency of small motors. Motors from 11 kW and up have their efficiency improved (1-2%). This is because the sine shape of the motor current is almost perfect at high switching frequency.

#### Efficiency of the system ( $\eta_{SYSTEM}$ )

To calculate the system efficiency, the efficiency of VLT 6000 HVAC (VLT) is multiplied by the efficiency of the motor (MOTOR):

$$\eta_{SYSTEM} = \eta_{VLT} \times \eta_{MOTOR}$$

Based on the graph outlined above, it is possible to calculate the system efficiency at different speeds.

### ■ Mains supply interference/harmonics

A frequency converter takes up a non-sinusoidal current from mains, which increases the input current  $I_{RMS}$ . A non-sinusoidal current can be transformed by means of a Fourier analysis and split up into sine wave currents with different frequencies, i.e. different harmonic currents  $I_N$  with 50 Hz as the basic frequency:

Harmonic currents	$I_1$	$I_5$	$I_7$
Hz	50 Hz	250 Hz	350 Hz

The harmonics do not affect the power consumption directly, but increase the heat losses in the installation (transformer, cables). Consequently, in plants with a rather high percentage of rectifier load, it is important to maintain harmonic currents at a low level to avoid overload of the transformer and high temperature in the cables.

Harmonic currents compared to the RMS input current:

	Input current
$I_{RMS}$	1.0
$I_1$	0.9
$I_5$	0.4
$I_7$	0.3
$I_{11-49}$	<0.1

To ensure low, harmonic currents, VLT 6000 HVAC has intermediate circuit coils as standard. This normally reduces the input current  $I_{RMS}$  by 40%, down to 40-45% THiD.

In some cases, there is a need for further suppression (e.g. retrofit with frequency converters). For this purpose Danfoss can offer two advanced harmonic filters AHF05 and AHF10, bringing the harmonic current down to around 5% and 10% respectively. For further details, see the operating instructions MG.80.BX.YY. For calculation of harmonic, Danfoss offers the software tool MCT31.

### ■ Power factor

The power factor is the relation between  $I_1$  and  $I_{RMS}$ .

The power factor for 3-phase control

$$= \frac{\sqrt{3} \times U \times I_1 \times \cos \varphi_1}{\sqrt{3} \times U \times I_{RMS}}$$

$$\text{Power factor} = \frac{I_1 \times \cos \varphi_1}{I_{RMS}} = \frac{I_1}{I_{RMS}} \quad \text{since } \cos \varphi = 1$$

The power factor indicates the extent to which the frequency converter imposes a load on the mains

Some of the harmonic currents might disturb communication equipment connected to the same transformer or cause resonance in connection with power-factor correction batteries. VLT 6000 HVAC has been designed in accordance with the following standards:

- IEC 1000-3-2
- IEEE 519-1992
- IEC 22G/WG4
- EN 50178
- VDE 160, 5.3.1.1.2

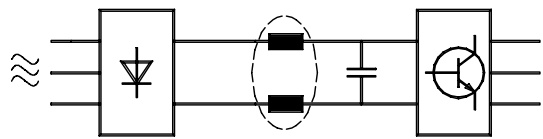

175HA34.00

The voltage distortion on the mains supply depends on the size of the harmonic currents multiplied by the mains impedance for the frequency in question. The total voltage distortion THD is calculated on the basis of the individual voltage harmonics using the following formula:

$$THD\% = \frac{\sqrt{U_5^2 + U_7^2 + \dots + U_N^2}}{U_1} \quad (U_N\% \text{ of } U)$$

supply. The lower the power factor, the higher the  $I_{RMS}$  for the same kW performance.

In addition, a high power factor indicates that the different harmonic currents are low.

$$I_{RMS} = \sqrt{I_1^2 + I_5^2 + I_7^2 + \dots + I_n^2}$$

**EMC test results (Emission, Immunity)**

The following test results have been obtained using a system with a frequency converter (with options if relevant), a screened control cable, a control box with potentiometer, as well as a motor and motor cable.

	Emission			
	Environment	Industrial environment	Housing, trades and light industries	
VLT 6002- 6011/ 380- 460V VLT 6002- 6005/ 200- 240V	Basic standard	EN 55011 Class A1	EN 55011 Class B	EN 61800- 3
Setup	Motor cable	Conducted 150 kHz- 30 MHz	Conducted 150 kHz- 30 MHz	Conducted/ radiated 150 kHz- 30 MHz
	300 m unscreened/ unarmoured	Yes 2)	No	No
VLT 6000 with RFI filter option	50 m br. screened/ armoured (Bookstyle 20m)	Yes	Yes	No
	150m br. screened/ armoured	Yes	Yes	No
	300 m unscreened/ unarmoured	Yes	No	No
	50 m br. screened/ armoured	Yes	Yes	No
	150m br. screened/ armoured	Yes	Yes	No
VLT 6000 with RFI- filter (+ LC- module)	Motor cable	Conducted 150 kHz- 30 MHz	Conducted 150 kHz- 30 MHz	Conducted/ radiated 150 kHz- 30 MHz
	300 m unscreened/ unarmoured	No	No	No
VLT 6000 w/ o RFI filter option <sup>4)5)</sup>	Motor cable	Conducted 150 kHz- 30 MHz	Conducted 150 kHz- 30 MHz	Conducted/ radiated 150 kHz- 30 MHz
	300 m unscreened/ unarmoured	No	No	No
VLT 6000 with RFI option	50 m br. screened/ armoured	Yes 2, 6)	No	No
	150 m br. screened/ armoured	Yes 6)	Yes 6)	Yes 1, 3, 6)
	300 m br. screened/ armoured	Yes 6)	Yes 6)	No

1) Does not apply to VLT 6152-6602, 380-460 V

2) Depending on installation conditions

3) VLT 6042- 6062, 200- 240 V

4) VLT 6152-6602, 380-460 V, fulfil class A2 with 50 m screened cable without RFI filter (typecode R0).

5) VLT 6102-6402, 525-600 V, fulfil class A2 with 150 m screened cable without RFI filter (typecode R0) and class A1 at 30 m screened cable with RFI filter option R1.

6) Does not apply to VLT 6102-6652, 525-600 V

In order to minimise the conducted noise to the mains supply and the radiated noise from the frequency converter system, the motor cables should be as short as possible and the screen ends should be made in accordance with the section on electrical installation.

**■ EMC Immunity**

In order to confirm immunity against interference from electrical phenomena, the following immunity test has been made on a system consisting of a frequency converter (with options, if relevant), a screened/armoured control cable and control box with potentiometer, motor cable and motor.

The tests were made in accordance with the following basic standards:

**EN 61000-4-2 (IEC 1000-4-2): Electrostatic discharges (ESD)**

Simulation of electrostatic discharges from human beings.

**EN 61000-4-3 (IEC 1000-4-3): Incoming electromagnetic field radiation, amplitude modulated**

Simulation of the effects of radar and radio communication equipment as well as mobile communications equipment.

**EN 61000-4-4 (IEC 1000-4-4): Burst transients**

Simulation of interference brought about by switching with a contactor, relays or similar devices.

**EN 61000-4-5 (IEC 1000-4-5): Surge transients**

Simulation of transients brought about e.g. by lightning that strikes near installations.

**ENV 50204: Incoming electromagnetic field, pulse modulated**

Simulation of the impact from GSM telephones.

**ENV 61000-4-6: Cable-borne HF**

Simulation of the effect of radio transmission equipment connected to supply cables.

**VDE 0160 class W2 test pulse: Mains transients**

Simulation of high-energy transients brought about by main fuse breakage, switching of power factor-correction capacitors, etc.

**■ Immunity, continued**

VLT 6002-6550 380-460 V, VLT 6002-6027 200-240 V								
	Burst	Surge		ESD	Radiated electro-magnetic field	Mains distortion	RF common mode voltage	Radiated radio freq.elect.field
<b>Basic standard</b>	IEC 1000-4-4	IEC 1000-4-5		1000-4-2	IEC 1000-4-3	VDE 0160	ENV 50141	ENV 50140
Acceptance criterion	B	B		B	A		A	A
Port connection	CM	DM	CM	-	-	CM	CM	
Line	OK	OK	-	-	-	OK	OK	-
Motor	OK	-	-	-	-	-	OK	-
Control lines	OK	-	OK	-	-	-	OK	-
PROFIBUS option	OK	-	OK	-	-	-	OK	-
Signal Interface<3 m	OK	-	-	-	-	-	-	-
Enclosure	-	-	-	OK	OK	-	-	OK
Load sharing	OK	-	-	-	-	-	OK	-
Standard bus	OK	-	OK	-	-	-	OK	-
<b>Basic specifications</b>				-	-	-		-
Line	4 kV/5kHz/DCN	2 kV/2Ω	4 kV/12Ω	-	-	2,3 x U <sub>N</sub> <sup>2)</sup>	10 V <sub>RMS</sub>	-
Motor	4 kV/5kHz/CCC	-	-	-	-	-	10 V <sub>RMS</sub>	-
Control lines	2 kV/5kHz/CCC	-	2 kV/2Ω <sup>1)</sup>	-	-	-	10 V <sub>RMS</sub>	-
PROFIBUS option	2 kV/5kHz/CCC	-	2 kV/2Ω <sup>1)</sup>	-	-	-	10 V <sub>RMS</sub>	-
Signal interface<3 m	1 kV/5kHz/CCC	-	-	-	-	-	10 V <sub>RMS</sub>	-
Enclosure	-	-	-	8 kV AD 6 kV CD	10 V/m	-	-	-
Load sharing	4 kV/5kHz/CCC	-	-	-	-	-	10 V <sub>RMS</sub>	-
Standard bus	2 kV/5kHz/CCC	-	4 kV/2 <sup>1)</sup>	-	-	-	10 V <sub>RMS</sub>	-

DM: Differential mode

CM: Common mode

CCC: Capacitive clamp coupling

DCN: Direct coupling network

1 ) Injection on cable shield

2 ) 2.3 x U<sub>N</sub>: max. test pulse 380 V<sub>AC</sub>: Class 2/1250 V<sub>PEAK</sub>, 415 V<sub>AC</sub>: Class 1/1350 V<sub>PEAK</sub>

## ■ Definitions

Definitions are given in alphabetical order.

### Analogue inputs:

The analogue inputs can be used for controlling various functions of the frequency converter.

There are two types of analogue inputs:

Current input, 0-20 mA

Voltage input, 0-10 V DC.

### Analogue ref.

A signal transmitted to input 53, 54 or 60.

Can be voltage or current.

### Analogue outputs:

There are two analogue outputs, which are able to supply a signal of 0-20 mA, 4-20 mA or a digital signal.

### Automatic motor adjustment, AMA:

Automatic motor adjustment algorithm, which determines the electrical parameters for the connected motor, at standstill.

### AWG:

AWG means American Wire Gauge, i.e. the American measuring unit for cable cross-section.

### Control command:

By means of the control unit and the digital inputs, it is possible to start and stop the connected motor.

Functions are divided into two groups, with the following priorities:

- Group 1 Reset, Coasting stop, Reset and Coasting stop, DC braking, Stop and the [OFF/ STOP] key.
- Group 2 Start, Pulse start, Reversing, Start reversing, Jog and Freeze output

Group 1 functions are called Start-disable commands.

The difference between group 1 and group 2 is that in group 1 all stop signals must be cancelled for the motor to start. The motor can then be started by means of a single start signal in group 2.

A stop command given as a group 1 command results in the display indication STOP.

A missing stop command given as a group 2 command results in the display indication STAND BY.

### Digital inputs:

The digital inputs can be used for controlling various functions of the frequency converter.

### Digital outputs:

There are four digital outputs, two of which activate a relay switch. The outputs are able to supply a 24 V DC (max. 40 mA) signal.

### f<sub>JOG</sub>

The output frequency from the VLT frequency converter transmitted to the motor when the jog function is activated (via digital terminals or serial communication).

### f<sub>M</sub>

The output frequency from the frequency converter transmitted to the motor.

### f<sub>M,N</sub>

The rated motor frequency (nameplate data).

### f<sub>MAX</sub>

Maximum output frequency transmitted to the motor.

### f<sub>MIN</sub>

Minimum output frequency transmitted to the motor.

### I<sub>M</sub>

The current transmitted to the motor.

### I<sub>M,N</sub>

The rated motor current (nameplate data).

### Initializing:

If initializing is carried out (see parameter 620 *Operating mode*), the frequency converter returns to the factory setting.

### I<sub>VLT,MAX</sub>

The maximum output current.

### I<sub>VLT,N</sub>

The rated output current supplied by the frequency converter.

### LCP:

The control panel, which makes up a complete interface for control and programming of VLT 6000 HVAC. The control panel is detachable and may, as an alternative, be installed up to 3 metres away from the frequency converter, i.e. in a front panel, by means of the installation kit option.

### LSB:

Least significant bit.

Used in serial communication.

**MCM:**

Stands for Mille Circular Mil, an American measuring unit for cable cross-section.

**MSB:**

Most significant bit.  
Used in serial communication.

 **$n_{M,N}$** 

The rated motor speed (nameplate data).

 **$\eta_{VLT}$** 

The efficiency of the frequency converter is defined as the ratio between the power output and the power input.

**On-line/off-line parameters:**

On-line parameters are activated immediately after the data value is changed. Off-line parameters are not activated until OK has been entered on the control unit.

**PID:**

The PID regulator maintains the desired speed (pressure, temperature, etc.) by adjusting the output frequency to match the varying load.

 **$P_{M,N}$** 

The rated power delivered by the motor (nameplate data).

**Preset ref.**

A permanently defined reference, which can be set from -100% to +100% of the reference range. There are four preset references, which can be selected via the digital terminals.

 **$Ref_{MAX}$** 

The maximum value which the reference signal may have. Set in parameter 205 *Maximum reference*,  $Ref_{MAX}$ .

 **$Ref_{MIN}$** 

The smallest value which the reference signal may have. Set in parameter 204 *Minimum reference*,  $Ref_{MIN}$ .

**Setup:**

There are four Setups, in which it is possible to save parameter settings. It is possible to change between the four parameter Setups and to edit one Setup, while another Setup is active.

**Start-disable command:**

A stop command that belongs to group 1 of the control commands - see this group.

**Stop command:**

See Control commands.

**Thermistor:**

A temperature-dependent resistor placed where the temperature is to be monitored (VLT or motor).

**Trip:**

A state which occurs in different situations, e.g. if the frequency converter is subjected to an over-temperature. A trip can be cancelled by pressing reset or, in some cases, automatically.

**Trip locked:**

Trip locked is a state which occurs in different situations, e.g. if the frequency converter is subject to an over-temperature. A locked trip can be cancelled by cutting off mains and restarting the frequency converter.

 **$U_M$** 

The voltage transmitted to the motor.

 **$U_{M,N}$** 

The rated motor voltage (nameplate data).

 **$U_{VLT, MAX}$** 

The maximum output voltage.

**VT characteristics:**

Variable torque characteristics, used for pumps and fans.



**■ Parameter overview and factory settings**

PNU #	Parameter description	Factory setting	Range	Changes during operation	4-Setup	Conversion index	Data type
001	<b>Language</b>	English		Yes	No	0	5
002	<b>Active Setup</b>	Setup 1		Yes	No	0	5
003	<b>Copying of Setups</b>	No copying		No	No	0	5
004	<b>LCP copy</b>	No copying		No	No	0	5
005	<b>Max value of user-defined readout</b>	100.00	0-999.999,99	Yes	Yes	-2	4
006	<b>Unit for user-defined readout</b>	No unit		Yes	Yes	0	5
007	<b>Big display readout</b>	Frequency, Hz		Yes	Yes	0	5
008	<b>Small display readout 1.1</b>	Reference. Unit		Yes	Yes	0	5
009	<b>Small display readout 1.2</b>	Motor current, A		Yes	Yes	0	5
010	<b>Small display readout 1.3</b>	Power, kW		Yes	Yes	0	5
011	<b>Unit of local reference</b>	Hz		Yes	Yes	0	5
012	<b>Hand start on LCP</b>	Enable		Yes	Yes	0	5
013	<b>OFF/STOP on LCP</b>	Enable		Yes	Yes	0	5
014	<b>Auto start on LCP</b>	Enable		Yes	Yes	0	5
015	<b>Reset on LCP</b>	Enable		Yes	Yes	0	5
016	<b>Lock for data change</b>	Not locked		Yes	Yes	0	5
017	<b>Operating state at power-up, local control</b>	Auto restart		Yes	Yes	0	5

## VLT® 6000 HVAC Series

PNU #	Parameter description	Factory setting	Range	Changes during operation	4-Setup	Conversion index	Data type
100	<b>Configuration</b>	Open loop		No	Yes	0	5
101	<b>Torque characteristics</b>	Automatic Energy Optimisation		No	Yes	0	5
102	<b>Motor power, <math>P_{M,N}</math></b>	Depends on the unit	0.25-500 kW	No	Yes	1	6
103	<b>Motor voltage, <math>U_{M,N}</math></b>	Depends on the unit	200-575 V	No	Yes	0	6
104	<b>Motor frequency, <math>f_{M,N}</math></b>	50 Hz	24-1000 Hz	No	Yes	0	6
105	<b>Motor current, <math>I_{M,N}</math></b>	Depends on the unit	0.01- $I_{VLT,MAX}$	No	Yes	-2	7
106	<b>Rated motor speed, <math>n_{M,N}</math></b>	Depends on par. 102 Motor power	100-60000 rpm	No	Yes	0	6
107	<b>Automatic motor adaptation, AMA</b>	Optimisation disable		No	No	0	5
108	<b>Start voltage of parallel motors</b>	Depends on par. 103	0.0 - par. 103	Yes	Yes	-1	6
109	<b>Resonance dampening</b>	100 %	0 - 500 %	Yes	Yes	0	6
110	<b>High break-away torque</b>	OFF	0.0 - 0.5 sec.	Yes	Yes	-1	5
111	<b>Start delay</b>	0.0 sec.	0.0 - 120.0 sec.	Yes	Yes	-1	6
112	<b>Motor preheater</b>	Disable		Yes	Yes	0	5
113	<b>Motor preheater DC current</b>	50 %	0 - 100 %	Yes	Yes	0	6
114	<b>DC braking current</b>	50 %	0 - 100 %	Yes	Yes	0	6
115	<b>DC braking time</b>	10 sec.	0.0 - 60.0 sec.	Yes	Yes	-1	6
116	<b>DC brake cut-in frequency</b>	OFF	0.0-par. 202	Yes	Yes	-1	6
117	<b>Motor thermal protection</b>	ETR Trip 1		Yes	Yes	0	5
118	<b>Motor power factor</b>	0.75	0.50 - 0.99	No	Yes	-2	6

PNU #	Parameter description	Factory setting	Range	Changes during operation	4-Setup	Conversion index	Data type
200	Output frequency range	0 - 120 Hz	0 - 1000 Hz	No	Yes	0	5
201	Output frequency low limit, $f_{MIN}$	0.0 Hz	0.0 - $f_{MAX}$	Yes	Yes	-1	6
202	Output frequency high limit, $f_{MAX}$	50 Hz	$f_{MIN}$ - par. 200	Yes	Yes	-1	6
203	Reference site	Hand/Auto linked reference		Yes	Yes	0	5
204	Minimum reference, $Ref_{MIN}$	0.000	0.000-par. 100	Yes	Yes	-3	4
205	Maximum reference, $Ref_{MAX}$	50.000	par. 100-999.999,999	Yes	Yes	-3	4
206	Ramp-up time	Depends on the unit	1 - 3600	Yes	Yes	0	7
207	Ramp-down time	Depends on the unit	1 - 3600	Yes	Yes	0	7
208	Automatic ramp-up/down	Enable		Yes	Yes	0	5
209	Jog frequency	10.0 Hz	0.0 - par. 100	Yes	Yes	-1	6
210	Reference type	Sum		Yes	Yes	0	5
211	Preset reference 1	0.00 %	-100.00 - 100.00 %	Yes	Yes	-2	3
212	Preset reference 2	0.00 %	-100.00 - 100.00 %	Yes	Yes	-2	3
213	Preset reference 3	0.00 %	-100.00 - 100.00 %	Yes	Yes	-2	3
214	Preset reference 4	0.00 %	-100.00 - 100.00 %	Yes	Yes	-2	3
215	Current limit, $I_{LIM}$	$1.0 \times I_{VLT,N[A]}$	$0, 1-1, 1 \times I_{VLT,N[A]}$	Yes	Yes	-1	6
216	Frequency bypass, bandwidth	0 Hz	0 - 100 Hz	Yes	Yes	0	6
217	Frequency bypass 1	120 Hz	0.0 - par.200	Yes	Yes	-1	6
218	Frequency bypass 2	120 Hz	0.0 - par.200	Yes	Yes	-1	6
219	Frequency bypass 3	120 Hz	0.0 - par.200	Yes	Yes	-1	6
220	Frequency bypass 4	120 Hz	0.0 - par.200	Yes	Yes	-1	6
221	Warning: Low current, $I_{Low}$	0.0 A	0.0 - par.222	Yes	Yes	-1	6
222	Warning: High current, $I_{HIGH}$	$I_{VLT,MAX}$	Par.221 - $I_{VLT,MAX}$	Yes	Yes	-1	6
223	Warning: Low frequency, $f_{Low}$	0.0 Hz	0.0 - par.224	Yes	Yes	-1	6
224	Warning: High frequency, $f_{HIGH}$	120.0 Hz	Par.223 - par.200/202	Yes	Yes	-1	6
225	Warning: Low reference, $Ref_{Low}$	-999,999.999	-999,999.999 - par.226	Yes	Yes	-3	4
226	Warning: High reference, $Ref_{HIGH}$	999,999.999	Par.225 - 999,999.999	Yes	Yes	-3	4
227	Warning: Low feedback, $FB_{Low}$	-999,999.999	-999,999.999 - par.228	Yes	Yes	-3	4
228	Warning: High feedback, $FB_{HIGH}$	999,999.999	Par. 227 - 999,999.999	Yes	Yes	-3	4

Changes during operation:

"Yes" means that the parameter can be changed, while the frequency converter is in operation. "No" means that the frequency converter must be stopped before a change can be made.

4-Setup:

"Yes" means that the parameter can be programmed individually in each of the four setups, i.e. the same parameter can have four different data values. "No" means that the data value will be the same in all four setups.

Conversion index:

This number refers to a conversion figure to be used when writing or reading by means of a frequency converter.

Conversion index	Conversion factor
74	0.1
2	100
1	10
0	1
-1	0.1
-2	0.01
-3	0.001
-4	0.0001

Data type:

Data type shows the type and length of the telegram.

Data type	Description
3	Integer 16
4	Integer 32
5	Unsigned 8
6	Unsigned 16
7	Unsigned 32
9	Text string

PNU #	Parameter description	Factory setting	Range	Changes during operation	4-Setup	Conversion index	Data type
300	<b>Terminal 16, Digital input</b>	Reset		Yes	Yes	0	5
301	<b>Terminal 17, Digital input</b>	Freeze output		Yes	Yes	0	5
302	<b>Terminal 18, Digital input</b>	Start		Yes	Yes	0	5
303	<b>Terminal 19, Digital input</b>	Reversing		Yes	Yes	0	5
304	<b>Terminal 27, Digital input</b>	Coasting stop, inverse		Yes	Yes	0	5
305	<b>Terminal 29, Digital input</b>	Jog		Yes	Yes	0	5
306	<b>Terminal 32, Digital input</b>	No operation		Yes	Yes	0	5
307	<b>Terminal 33, Digital input</b>	No operation		Yes	Yes	0	5
308	<b>Terminal 53, analogue input voltage</b>	Reference		Yes	Yes	0	5
309	<b>Terminal 53, min. scaling</b>	0.0 V	0.0 - 10.0 V	Yes	Yes	-1	5
310	<b>Terminal 53, max. scaling</b>	10.0 V	0.0 - 10.0 V	Yes	Yes	-1	5
311	<b>Terminal 54, analogue input voltage</b>	No operation		Yes	Yes	0	5
312	<b>Terminal 54, min. scaling</b>	0.0 V	0.0 - 10.0 V	Yes	Yes	-1	5
313	<b>Terminal 54, max. scaling</b>	10.0 V	0.0 - 10.0 V	Yes	Yes	-1	5
314	<b>Terminal 60, analogue input current</b>	Reference		Yes	Yes	0	5
315	<b>Terminal 60, min. scaling</b>	4.0 mA	0.0 - 20.0 mA	Yes	Yes	-4	5
316	<b>Terminal 60, max. scaling</b>	20.0 mA	0.0 - 20.0 mA	Yes	Yes	-4	5
317	<b>Time out</b>	10 sec.	1 - 99 sec.	Yes	Yes	0	5
318	<b>Function after time out</b>	Off		Yes	Yes	0	5
319	<b>Terminal 42, output</b>	0 - I <sub>MAX</sub> 0-20 mA		Yes	Yes	0	5
320	<b>Terminal 42, output, pulse scaling</b>	5000 Hz	1 - 32000 Hz	Yes	Yes	0	6
321	<b>Terminal 45, output</b>	0 - f <sub>MAX</sub> 0-20 mA		Yes	Yes	0	5
322	<b>Terminal 45, output, pulse scaling</b>	5000 Hz	1 - 32000 Hz	Yes	Yes	0	6
323	<b>Relay 1, output function</b>	Alarm		Yes	Yes	0	5
324	<b>Relay 01, ON delay</b>	0.00 sec.	0 - 600 sec.	Yes	Yes	0	6
325	<b>Relay 01, OFF delay</b>	0.00 sec.	0 - 600 sec.	Yes	Yes	0	6
326	<b>Relay 2, output function</b>	Running		Yes	Yes	0	5
327	<b>Pulse reference, max. frequency</b>	5000 Hz	Depends on input terminal	Yes	Yes	0	6
328	<b>Pulse feedback, max. frequency</b>	25000 Hz	0 - 65000 Hz	Yes	Yes	0	6
364	<b>Terminal 42, bus control</b>	0	0.0 - 100 %	Yes	Yes	-1	6
365	<b>Terminal 45, bus control</b>	0	0.0 - 100 %	Yes	Yes	-1	6

Changes during operation:

"Yes" means that the parameter can be changed, while the frequency converter is in operation. "No" means that the frequency converter must be stopped before a change can be made.

4-Setup:

"Yes" means that the parameter can be programmed individually in each of the four setups, i.e. the same parameter can have four different data values. "No" means that the data value will be the same in all four setups.

Conversion index:

This number refers to a conversion figure to be used when writing or reading by means of a frequency converter.

Conversion index	Conversion factor
74	0.1
2	100
1	10
0	1
-1	0.1
-2	0.01
-3	0.001
-4	0.0001

Data type:

Data type shows the type and length of the telegram.

Data type	Description
3	Integer 16
4	Integer 32
5	Unsigned 8
6	Unsigned 16
7	Unsigned 32
9	Text string

PNU #	Parameter description	Factory setting	Range	Changes during operation	4-Setup	Conversion index	Data type
400	<b>Reset function</b>	Manual reset		Yes	Yes	0	5
401	<b>Automatic restart time</b>	10 sec.	0 - 600 sec.	Yes	Yes	0	6
402	<b>Flying start</b>	Disable		Yes	Yes	-1	5
403	<b>Sleep mode timer</b>	Off	0 - 300 sec.	Yes	Yes	0	6
404	<b>Sleep frequency</b>	0 Hz	$f_{MIN}$ -Par.405	Yes	Yes	-1	6
405	<b>Wake up frequency</b>	50 Hz	Par.404 - $f_{MAX}$	Yes	Yes	-1	6
406	<b>Boost setpoint</b>	100 %	1 - 200 %	Yes	Yes	0	6
407	<b>Switching frequency</b>	Depends on the unit	1.5 - 14.0 kHz	Yes	Yes	2	5
408	<b>Interference reduction method</b>	ASFM		Yes	Yes	0	5
409	<b>Function in case of no load</b>	Warning		Yes	Yes	0	5
410	<b>Function at mains failure</b>	Trip		Yes	Yes	0	5
411	<b>Function at overtemperature</b>	Trip		Yes	Yes	0	5
412	<b>Trip delay overcurrent, <math>I_{LM}</math></b>	60 sec.	0 - 60 sec.	Yes	Yes	0	5
413	<b>Minimum feedback, <math>FB_{MIN}</math></b>	0.000	-999,999.999 - $FB_{MIN}$	Yes	Yes	-3	4
414	<b>Maximum feedback, <math>FB_{MAX}</math></b>	100.000	$FB_{MIN}$ - 999,999.999	Yes	Yes	-3	4
415	<b>Units relating to closed loop</b>	%		Yes	Yes	-1	5
416	<b>Feedback conversion</b>	Linear		Yes	Yes	0	5
417	<b>Feedback calculation</b>	Maximum		Yes	Yes	0	5
418	<b>Setpoint 1</b>	0.000	$FB_{MIN}$ - $FB_{MAX}$	Yes	Yes	-3	4
419	<b>Setpoint 2</b>	0.000	$FB_{MIN}$ - $FB_{MAX}$	Yes	Yes	-3	4
420	<b>PID normal/inverse control</b>	Normal		Yes	Yes	0	5
421	<b>PID anti windup</b>	On		Yes	Yes	0	5
422	<b>PID start-up frequency</b>	0 Hz	$F_{MIN}$ - $F_{MAX}$			-1	6
423	<b>PID proportional gain</b>	0.01	0.0-10.00	Yes	Yes	-2	6
424	<b>PID integration time</b>	Off	0.01-9999.00 s.(off)	Yes	Yes	-2	7
425	<b>PID differentiation time</b>	Off	0.0 (Off) - 10.00 sec.	Yes	Yes	-2	6
426	<b>PID differentiator gain limit</b>	5.0	5.0 - 50.0	Yes	Yes	-1	6
427	<b>PID lowpass filter time</b>	0.01	0.01 - 10.00	Yes	Yes	-2	6
430	<b>Fire mode</b>	Disable		Yes	Yes	0	5
431	<b>Fire mode Reference Frequency, Hz</b>	50 Hz 60 Hz (US)	Min Freq (par 201) to Max Freq (par 202)	Yes	Yes	-1	3
432	<b>Fire mode bypass delay, s</b>	0 s	0 - 600 s	Yes	Yes	0	3
483	<b>Dynamic DC Link Compensation</b>	On		No	No	0	5

PNU #	Parameter description	Factory setting	Range	Changes during operation	4-Setup	Conversion index	Data type
500	<b>Protocol</b>	FC protocol		Yes	Yes	0	5
501	<b>Address</b>	1	Depends on par. 500	Yes	No	0	6
502	<b>Baudrate</b>	9600 Baud		Yes	No	0	5
503	<b>Coasting</b>	Logic or		Yes	Yes	0	5
504	<b>DC-brake</b>	Logic or		Yes	Yes	0	5
505	<b>Start</b>	Logic or		Yes	Yes	0	5
506	<b>Direction of rotation</b>	Logic or		Yes	Yes	0	5
507	<b>Selection of Setup</b>	Logic or		Yes	Yes	0	5
508	<b>Selection of preset reference</b>	Logic or		Yes	Yes	0	5
509	<b>Data read-out: Reference %</b>			No	No	-1	3
510	<b>Data read-out: Reference unit</b>			No	No	-3	4
511	<b>Data read-out: Feedback</b>			No	No	-3	4
512	<b>Data read-out: Frequency</b>			No	No	-1	6
513	<b>User defined read-out</b>			No	No	-2	7
514	<b>Data read-out: Current</b>			No	No	-2	7
515	<b>Data read-out: Power, kW</b>			No	No	1	7
516	<b>Data read-out: Power, HP</b>			No	No	-2	7
517	<b>Data read-out: Motor voltage</b>			No	No	-1	6
518	<b>Data read-out: DC link voltage</b>			No	No	0	6
519	<b>Data read-out: Motor temp.</b>			No	No	0	5
520	<b>Data read-out: VLT temp.</b>			No	No	0	5
521	<b>Data read-out: Digital input</b>			No	No	0	5
522	<b>Data read-out: Terminal 53, analogue input</b>			No	No	-1	3
523	<b>Data read-out: Terminal 54, analogue input</b>			No	No	-1	3
524	<b>Data read-out: Terminal 60, analogue input</b>			No	No	-4	3
525	<b>Data read-out: Pulse reference</b>			No	No	-1	7
526	<b>Data read-out: External reference %</b>			No	No	-1	3
527	<b>Data read-out: Status word, hex</b>			No	No	0	6
528	<b>Data read-out: Heat sink temperature</b>			No	No	0	5
529	<b>Data read-out: Alarm word, hex</b>			No	No	0	7
530	<b>Data read-out: Control word, hex</b>			No	No	0	6
531	<b>Data read-out: Warning word, hex</b>			No	No	0	7
532	<b>Data read-out: Extended status word, hex</b>			No	No	0	7
533	<b>Display text 1</b>			No	No	0	9
534	<b>Display text 2</b>			No	No	0	9
535	<b>Busfeedback 1</b>			No	No	0	3
536	<b>Busfeedback 2</b>			No	No	0	3
537	<b>Data read-out: Relay status</b>			No	No	0	5
538	<b>Data read-out: Warning word 2</b>			No	No	0	7
555	<b>Bus time interval</b>	1 sec.	1 - 99 sec.	Yes	Yes	0	5
556	<b>Bus time interval function</b>	OFF		Yes	Yes	0	5
560	<b>N2 override release time</b>	OFF	1 - 65534 sec.	Yes	No	0	6
565	<b>FLN Bus time interval</b>	60 sec.	1 - 65534 sec.	Yes	Yes	0	6
566	<b>FLN Bus time interval function</b>	OFF		Yes	Yes	0	5
570	<b>Modbus parity and message framing</b>	No parity	1 stopbit	Yes	Yes	0	5
571	<b>Modbus communications timeout</b>	100 ms	10 - 2000 ms	Yes	Yes	-3	6

PNU #	Parameter description	Factory setting	Range	Changes during operation	4-Setup	Conversion index	Data type
600	Operating data: Operating hours			No	No	74	7
601	Operating data: Hours run			No	No	74	7
602	Operating data: kWh counter			No	No	3	7
603	Operating data: Number of cut-ins			No	No	0	6
604	Operating data: Number of overtemps			No	No	0	6
605	Operating data: Number of overvoltages			No	No	0	6
606	Data log: Digital input			No	No	0	5
607	Data log: Control word			No	No	0	6
608	Data log: Status word			No	No	0	6
609	Data log: Reference			No	No	-1	3
610	Data log: Feedback			No	No	-3	4
611	Data log: Output frequency			No	No	-1	3
612	Data log: Output voltage			No	No	-1	6
613	Data log: Output current			No	No	-2	3
614	Data log: DC link voltage			No	No	0	6
615	Fault log: Error code			No	No	0	5
616	Fault log: Time			No	No	0	7
617	Fault log: Value			No	No	0	3
618	Reset of kWh counter	No reset		Yes	No	0	5
619	Reset of hours-run counter	No reset		Yes	No	0	5
620	Operating mode	Normal function		Yes	No	0	5
621	Nameplate: Unit type			No	No	0	9
622	Nameplate: Power component			No	No	0	9
623	Nameplate: VLT ordering no.			No	No	0	9
624	Nameplate: Software version no.			No	No	0	9
625	Nameplate: LCP identification no.			No	No	0	9
626	Nameplate: Database identification no.			No	No	-2	9
627	Nameplate: Power component identification no.			No	No	0	9
628	Nameplate: Application option type			No	No	0	9
629	Nameplate: Application option ordering no.			No	No	0	9
630	Nameplate: Communication option type			No	No	0	9
631	Nameplate: Communication option ordering no.			No	No	0	9
655	Fault log: Real time			No	No	-4	7

Changes during operation:

"Yes" means that the parameter can be changed, while the frequency converter is in operation. "No" means that the frequency converter must be stopped before a change can be made.

4-Setup:

"Yes" means that the parameter can be programmed individually in each of the four setups, i.e. the same parameter can have four different data values. "No" means that the data value will be the same in all four setups.

Conversion index:

This number refers to a conversion figure to be used when writing or reading by means of a frequency converter.

Conversion index	Conversion factor
74	0.1
2	100
1	10
0	1
-1	0.1
-2	0.01
-3	0.001
-4	0.0001

Data type:

Data type shows the type and length of the telegram.

Data type	Description
3	Integer 16
4	Integer 32
5	Unsigned 8
6	Unsigned 16
7	Unsigned 32
9	Text string

**■ Index**
**A**

AWG.....	159
Accuracy of display readout (parameters 009-012, Display readout): .....	24
Acoustic noise .....	151
AEO - Automatic Energy Optimization.....	10
Aggressive environments .....	147
Air humidity .....	153
Analog output .....	108
Analogue inputs.....	105
Anti windup .....	126
Application functions 400-427 .....	115
Auto start.....	103
Auto start on LCP .....	84
Automatic motor adaptation, AMA.....	88
Available literature .....	8

**B**

Bus connection .....	68
----------------------	----

**C**

control panel - LCP .....	71
Cable clamp .....	56
Cable lengths and cross-sections: .....	23
Cables .....	48
CE labelling .....	15
Change parameter data .....	78
Changing data .....	76
Closed loop.....	119
Coasting stop .....	102
Connection examples .....	69
Control card .....	66
Control card, 24 V DC supply: .....	23
Control card, analogue inputs .....	22
Control card, digital inputs:.....	22
Control card, digital/pulse and analogue outputs: .....	22
Control card, RS 485 serial communication:.....	23
Control characteristics:.....	24
Control keys .....	71
Control principle .....	9
Control unit LCP .....	71
Conversion index: .....	163
Cooling.....	45
Copying of Setups .....	80
Current limit .....	97

**D**

Derating for ambient temperature .....	151
Derating for high switching frequency .....	152

direction of motor rotation .....	65
Data change lock.....	103
Data log.....	131
DC braking .....	90
DC braking, inverse .....	102
DC bus connection .....	66
Definitions .....	159
Derating for air pressure .....	152
Derating for long motor cables .....	152
Derating for running at low speed .....	152
Digital inputs .....	101
Digital speed up/down .....	70
Direction of motor rotation .....	65
Display .....	71
Display mode.....	134
Display readout .....	83

**E**

EMC test results .....	156
Earth connection .....	66
Earth fault .....	149
Earth leakage current.....	148
Earthing.....	48, 56
Efficiency .....	154
Electrical installation - earthing of control cables.....	56
Electrical installation, control cables.....	67
Electrical installation, enclosures.....	94
Electrical installation, power cables .....	95
EMC correct electrical installation .....	53
EMC Immunity .....	157
EMC-correct cables .....	55
Enable RTC .....	104
Enclosures .....	58
Equalising cable,.....	56
Example of application .....	11
External 24 Volt DC supply .....	23
Externals.....	24
Extra protection .....	48
Extreme running conditions .....	149

**F**

Factory settings .....	161
Faultlog .....	131
Feedback.....	105
Feedback .....	119
Feedback handling .....	123
Fire mode .....	13, 103, 128
Fire Mode bypass delay, s.....	128
Fire Mode inverse .....	103
Fire Mode reference frequency, Hz .....	128
Flying start .....	115
Freeze output .....	102



Freeze reference .....	102	Mechanical installation .....	45
Frequency bypass.....	97	Motor cables .....	65
Function at mains failure .....	118	Motor connection .....	64
Function at overtemperature .....	118	Motor current.....	87
Function in case of no load .....	118	Motor frequency .....	87
Fuses.....	38	Motor power.....	86
		Motor speed.....	88
		Motor thermal protection .....	66, 91
		Motorvoltage .....	87
<b>G</b>		<b>N</b>	
Galvanic isolation .....	148	Nameplate .....	133, 134
General warning .....	5	No function .....	102
		No operation.....	105
		NOISE REDUCTION .....	118
<b>H</b>		<b>O</b>	
Hand start .....	103	OFF/STOP on LCP.....	84
Hand start on LCP .....	84	Operating mode .....	132
Hand/Auto linked reference .....	94	Ordering form .....	20
Harmonic filter .....	129	Output frequency .....	92
Heat emission from VLT 6000 HVAC .....	53		
High voltage test.....	53	<b>P</b>	
High voltage warning .....	48	Parallel coupling .....	65
High-voltage relay .....	119	Parameter Data .....	78
		PC software.....	15
		Peak voltage on motor .....	150
<b>I</b>		PELV.....	148
IT mains.....	50	PID for process control.....	121
Indicator lamps.....	71, 72	PID integration time .....	127
Initialisation.....	76	PLC.....	56
Inputs and outputs 300-365 .....	101	Potentiometer reference .....	70
Installation of 24 Volt external DC supply .....	66	Preset reference .....	97, 102
Interference reduction method .....	118	Programming .....	79
		Protection .....	25
		Pulse feedback .....	103
		Pulse reference .....	103
		Pulse scaling.....	110
<b>J</b>		<b>Q</b>	
Jog.....	103	Quick Menu .....	77
<b>L</b>		<b>R</b>	
Low current .....	98	Ramp-down time.....	95
Language.....	79	Ramp-uptime.....	94
LCP copy.....	80	Reference .....	105
Load and Motor 100-117 .....	86	Reference handling .....	93
Local control.....	72	Reference type .....	96
Local Control Panel .....	71		
Lock for data change .....	84		
Lowpass.....	127		
<b>M</b>			
Maximum reference .....	94		
Mains connection .....	98		
Mains supply (L1, L2, L3): .....	21		
Max. imbalance of supply voltage: .....	21		
Mechanical dimensions .....	41		

References and Limits .....	92
Relay 1 .....	111
Relay 2 .....	111
Relay card .....	135
Relay outputs .....	111
Relay outputs: .....	23
Relay01 .....	113
Reset .....	102
Reset and coasting stop, inverse .....	102
Reset function .....	115
Reset on LCP .....	84
Reversing .....	102
Reversing and start .....	102
RFI switch .....	50
Rise time .....	150
Run permissive.....	70, 103

## S

screw sizes .....	64
Serial communication .....	129
Safety interlock.....	102
Safety regulations .....	5
Screened/armoured cables .....	48
Selection of Setup.....	102
Serial communication.....	15, 56
Service functions .....	130
Setpoint.....	125
Setup.....	79
Setup configuration .....	79
Setup of user-defined readout .....	80
Single-pole start/stop.....	70
Sleep mode.....	116
Speed up and speed down .....	102
Start .....	102
Status messages .....	139
Switches 1-4 .....	68
Switching frequency .....	117
Switching on the input .....	150

## T

Trip locked .....	160
Technical data .....	26
Thermistor.....	105
Tightening-up torque .....	64
Time out .....	107
Torque characteristics .....	21, 86
Transmitter connection.....	70
Trip delay overcurrent, I <sub>LIM</sub> .....	119
Trip locked .....	141
Type code ordering number string.....	16

## U

Unintended start.....	5
Units .....	119

## V

Ventilation of integrated VLT 6000 HVAC .....	53
Vibration and shock.....	153
VLT output data (U, V, W): .....	21

## W

Warning .....	5
Warning against unintended start.....	5
Warning: High frequency .....	99
Warning: High reference .....	99
Warnings and alarms .....	141

## 2

2-zone regulation .....	70
-------------------------	----