



Quick Guide

VLT[®] Micro Drive

1 Quick Guide

1.1 Safety

1.1.1 Warnings

⚠ WARNING

HIGH VOLTAGE!

Adjustable frequency drives contain high voltage when connected to AC line power. Installation, start-up, and maintenance should be performed by qualified personnel only. Failure to perform installation, start-up, and maintenance by qualified personnel could result in death or serious injury.

High Voltage

Adjustable frequency drives are connected to hazardous AC line voltage. Extreme care should be taken to protect against shock. Only trained personnel familiar with electronic equipment should install, start, or maintain this equipment.

Touching the electrical parts may be fatal - even after the equipment has been disconnected from line power. Also make sure that other voltage inputs have been disconnected (linkage of DC intermediate circuit). Be aware that there may be high voltage on the DC link even when the LEDs are turned off. Before touching any potentially live parts of the adjustable frequency drive, wait at least 4 minutes for all M1, M2 and M3 sizes. Wait at least 15 minutes for all M4 and M5 sizes.

⚠ WARNING

UNINTENDED START!

When the adjustable frequency drive is connected to AC line power, the motor may start at any time. The adjustable frequency drive, motor, and any driven equipment must be in operational readiness. Failure to be in operational readiness when the adjustable frequency drive is connected to AC line power could result in death, serious injury, equipment, or property damage.

Unintended Start

When the adjustable frequency drive is connected to the AC line power, the motor may be started by means of an external switch, a serial bus command, an input reference signal, or a cleared fault condition. Use appropriate cautions to guard against an unintended start.

Leakage Current (>3.5mA)

Follow national and local codes regarding protective grounding of equipment with a leakage current > 3.5mA.

Adjustable frequency drive technology implies high frequency switching at high power. This will generate a leakage current in the ground connection. A fault current in the Adjustable frequency drive at the output power terminals might contain a DC component which can charge the filter capacitors and cause a transient ground current. The ground leakage current depends on various system configurations including RFI filtering, shielded motor cables, and Adjustable frequency drive power.

EN/IEC61800-5-1 (Power Drive System Product Standard) requires special care if the leakage current exceeds 3.5mA. Grounding must be reinforced in one of the following ways:

- Ground wire of at least 10mm².
- Two separate ground wires both complying with the dimensioning rules.

See EN 60364-5-54 § 543.7 for further information.

Using RCDs

Where residual current devices (RCDs), also known as ground leakage circuit breakers (ELCBs), are used, comply with the following:

Use RCDs of type B only which are capable of detecting AC and DC currents.

Use RCDs with an inrush delay to prevent faults due to transient ground currents.

Dimension RCDs according to the system configuration and environmental considerations.

Motor Thermal Protection

Motor overload protection is possible by setting Parameter 1-90 Motor thermal protection to the value ETR trip. For the North American market: Implemented ETR function provide class 20 motor overload protection, in accordance with NEC.

Installation at High Altitudes

For altitudes above 6,600 feet [2 km], please contact Danfoss regarding PELV.

1.1.2 Safety Instructions

- Make sure the adjustable frequency drive is properly grounded.
- Do not remove AC line input connections, motor connections or other power connections while

the adjustable frequency drive is connected to line power.

- Protect users against supply voltage.
- Protect the motor against overloading according to national and local regulations.
- The ground leakage current exceeds 3.5 mA.
- The [OFF] key is not a safety switch. It does not disconnect the adjustable frequency drive from line power.

1.2 Introduction

1.2.1 Available Literature

NOTE!

This Quick Guide contains the basic information necessary for installing and running the adjustable frequency drive.

If more information is needed, the literature below can be downloaded from:

<http://www.danfoss.com/BusinessAreas/DrivesSolutions/Documentations>

Title	Literature no.
VLT Micro Drive FC 51 Instruction Manual	MG.02.AX.YY
VLT Micro Drive FC 51 Quick Guide	MG.02.BX.YY
VLT Micro Drive FC 51 Programming Guide	MG.02.CX.YY
FC 51 LCP Mounting Instruction	MI.02.AX.YY
FC 51 De-coupling Plate Mounting Instruction	MI.02.BX.YY
FC 51 Remote Mounting Kit Mounting Instruction	MI.02.CX.YY
FC 51 DIN Rail Kit Mounting Instruction	MI.02.DX.YY
FC 51 IP21 Kit Mounting Instruction	MI.02.EX.YY
FC 51 Nema1 Kit Mounting Instruction	MI.02.FX.YY

X = Revision Number, Y = Language code

1.2.2 Approvals

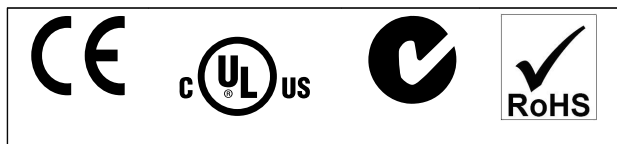

1.2.3 IT Line power

NOTE!

IT Line power

Installation on an isolated line power source, i.e., IT line power.

Max. supply voltage allowed when connected to line power: 440V.

As an option, Danfoss offers recommended line filters for improved harmonics performance.

1.2.4 Avoid Unintended Start

While the adjustable frequency drive is connected to line power, the motor can be started/stopped using digital commands, bus commands, references or via the LCP.

- Disconnect the adjustable frequency drive from line power whenever personal safety considerations make it necessary to avoid unintended start of any motors.
- To avoid unintended start, always activate the [OFF] key before changing parameters.

1.2.5 Disposal Instructions

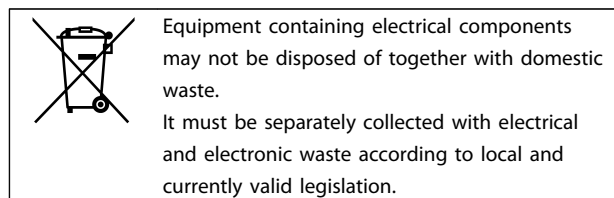

1.3 Installation

1.3.1 Before Commencing Repair Work

1. Disconnect FC 51 from line power (and external DC supply, if present.)
2. Wait for 4 minutes (M1, M2 and M3) and 15 minutes (M4 and M5) for the DC link to discharge.
3. Disconnect DC bus terminals and brake terminals (if present).
4. Remove motor cable.

1.3.2 Side-by-Side Installation

The adjustable frequency drive can be mounted side-by-side for IP20 rating units and requires 3.4 in. [100 mm] clearance above and below for cooling. Please refer to the specifications near the end of this document for details on environmental ratings for the adjustable frequency drive.

1.3.3 Mechanical Dimensions

A template for drilling can be found on the flap of the packaging.

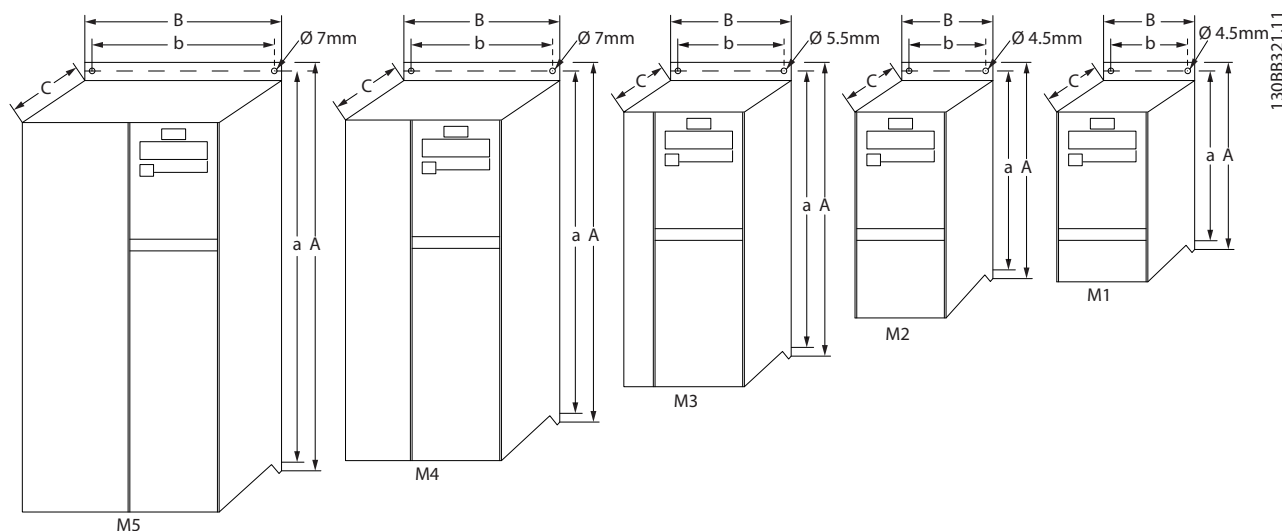

Figure 1.1 Mechanical Dimensions.

Frame Size	Power (HP [kW])			Height (in [mm])			Width (in [mm])		Depth ¹⁾ (in [mm])	Max. Weight
	1 X 200–240V	3 X 200–240V	3 X 380–480V	A	A (incl. decoupling plate)	a	B	b	C	lbs [Kg]
M1	0.24–1 [0.18–0.75]	0.34–1 [0.25–0.75]	0.5–1 [0.37–0.75]	5.91 [150]	8.1 [205]	5.53 [140.4]	2.8 [70]	2.17 [55]	5.83 [148]	2.43 [1.1]
M2	2 [1.5]	2 [1.5]	2–3 [1.5–2.2]	6.93 [176]	9.10 [230]	6.55 [166.4]	2.95 [75]	2.32 [59]	6.61 [168]	3.53 [1.6]
M3	3 [2.2]	3–5 [2.2–3.7]	4–10 [3.0–7.5]	9.41 [239]	11.57 [294]	8.90 [226]	3.54 [90]	2.72 [69]	7.64 [194]	6.61 [3.0]
M4			15–20 [11.0–15.0]	11.50 [292]	13.68 [347.5]	10.72 [272.4]	4.92 [125]	3.82 [97]	9.49 [241]	13.23 [6.0]
M5			25–30 [18.5–22.0]	13.19 [335]	15.26 [387.5]	12.40 [315]	6.50 [165]	5.5 [140]	9.76 [248]	20.94 [9.5]

¹⁾ For LCP with potentiometer, please add 0.3 in [7.6 mm].

Table 1.1 Mechanical Dimensions

1.3.4 Electrical Installation in General

NOTE!

All cabling must comply with national and local regulations on cable cross-sections and ambient temperature. Copper conductors required, (140°–167°F [60°–75°C]) recommended.

Frame Size	Power (HP [kW])			Torque (Nm)					
	1 x 200–240V	3 x 200–240V	3 x 380–480V	Line	Motor	DC connection/Brake	Control Terminals	Ground	Relay
M1	0.24–1 [0.18–0.75]	0.34–1 [0.25–0.75]	0.5–1 [0.37–0.75]	1.4	0.7	Spade ¹⁾	0.15	3	0.5
M2	2 [1.5]	2 [1.5]	2–3 [1.5–2.2]	1.4	0.7	Spade ¹⁾	0.15	3	0.5
M3	3 [2.2]	3–5 [2.2–3.7]	4–10 [3.0–7.5]	1.4	0.7	Spade ¹⁾	0.15	3	0.5
M4			15–20 [11.0–15.0]	1.3	1.3	1.3	0.15	3	0.5
M5			25–30 [18.5–22.0]	1.3	1.3	1.3	0.15	3	0.5

¹⁾ Spade connectors (0.25 in [6.3 mm] Faston plugs)

Table 1.2 Tightening of Terminals

1.3.5 Fuses

Branch circuit protection:

In order to protect the installation against electrical and fire hazards, all branch circuits in an installation, switch gear, machines, etc. must be short-circuited and overcurrent protected according to national/international regulations.

Provide overload protection to avoid overheating of the cables in the installation. Overcurrent protection must always be carried out according to national regulations. Fuses must be designed for protection in a circuit capable of supplying a maximum of 100,000 A_{rms} (symmetrical), 480V maximum.

Short circuit protection:

Danfoss recommends using the fuses mentioned in the following tables to protect service personnel or other equipment in case of an internal failure in the unit or short-circuit on the DC link. The adjustable frequency drive provides full short circuit protection in case of a short-circuit on the motor or brake output.

Non UL compliance:

If UL/cUL is not to be complied with, Danfoss recommends using the fuses mentioned in the table below, which will ensure compliance with EN50178/IEC61800-5-1: In case of malfunction, not following the fuse recommendation may result in damage to the adjustable frequency drive.

Overcurrent protection:

FC 51	Max. Fuses UL						Max. fuses non-UL
	Bussmann	Bussmann	Bussmann	Littel fuse	Ferraz-Shawmut	Ferraz-Shawmut	
1 X 200-240V							
kW	Type RK1	Type J	Type T	Type RK1	Type CC	Type RK1	Type gG
0K18 - 0K37	KTN-R15	JKS-15	JJN-15	KLN-R15	ATM-R15	A2K-15R	16A
0K75	KTN-R25	JKS-25	JJN-25	KLN-R25	ATM-R25	A2K-25R	25A
1K5	KTN-R35	JKS-35	JJN-35	KLN-R35	-	A2K-35R	35A
2K2	KTN-R50	JKS-50	JJN-50	KLN-R50	-	A2K-50R	50A
3 x 200-240V							
0K25	KTN-R10	JKS-10	JJN-10	KLN-R10	ATM-R10	A2K-10R	10A
0K37	KTN-R15	JKS-15	JJN-15	KLN-R15	ATM-R15	A2K-15R	16A
0K75	KTN-R20	JKS-20	JJN-20	KLN-R20	ATM-R20	A2K-20R	20A
1K5	KTN-R25	JKS-25	JJN-25	KLN-R25	ATM-R25	A2K-25R	25A
2K2	KTN-R40	JKS-40	JJN-40	KLN-R40	ATM-R40	A2K-40R	40A
3K7	KTN-R40	JKS-40	JJN-40	KLN-R40	-	A2K-40R	40A
3 x 380-480V							
0K37 - 0K75	KTS-R10	JKS-10	JJS-10	KLS-R10	ATM-R10	A6K-10R	10A
1K5	KTS-R15	JKS-15	JJS-15	KLS-R15	ATM-R15	A2K-15R	16A
2K2	KTS-R20	JKS-20	JJS-20	KLS-R20	ATM-R20	A6K-20R	20A
3K0	KTS-R40	JKS-40	JJS-40	KLS-R40	ATM-R40	A6K405R	40A
4K0	KTS-R40	JKS-40	JJS-40	KLS-R40	ATM-R40	A6K-40R	40A
5K5	KTS-R40	JKS-40	JJS-40	KLS-R40	-	A6K-40R	40A
7K5	KTS-R40	JKS-40	JJS-40	KLS-R40	-	A6K-40R	40A
11K0	KTS-R60	JKS-60	JJS-60	KLS-R60	-	A6K-60R	63A
15K0	KTS-R60	JKS-60	JJS-60	KLS-R60	-	A6K-60R	63A
18K5	KTS-R60	JKS-60	JJS-60	KLS-R60	-	A6K-60R	80A
22K0	KTS-R60	JKS-60	JJS-60	KLS-R60	-	A6K-60R	80A

Table 1.3 Fuses

1.3.6 Connecting to Line Power and Motor

The adjustable frequency drive is designed to operate all standard three-phased asynchronous motors.

The adjustable frequency drive is designed to accept mains/motor cables with a maximum cross-section of 4mm²/10 AWG (M1, M2 and M3) and maximum cross-section 16mm²/6 AWG (M4 and M5).

- Use a shielded/armored motor cable to comply with EMC emission specifications, and connect this cable to both the decoupling plate and the motor metal.
- Keep motor cable as short as possible to reduce the noise level and leakage currents.
- For further details on mounting of the decoupling plate, please see instruction MI.02.BX.YY.
- Also see EMC-Correct Installation in Instruction Manual MG.02.AX.YY.

Step 1: First, mount the ground wires to the ground terminal.

Step 2: Connect the motor to terminals U, V and W.

Step 3: Mount line power supply to terminals L1/L, L2 and L3/N (3-phase) or L1/L and L3/N (single-phase) and tighten.

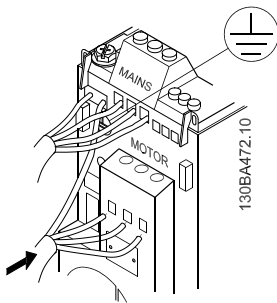

Figure 1.2 Mounting of Ground Cable, Line Power and Motor Wires

1.3.7 Control Terminals

All control cable terminals are located underneath the terminal cover in front of the adjustable frequency drive. Remove the terminal cover using a screwdriver.

NOTE!

See back of terminal cover for outlines of control terminals and switches.

NOTE!

Do not operate switches with power on the adjustable frequency drive.

Parameter 6-19 must be set according to Switch 4 position.

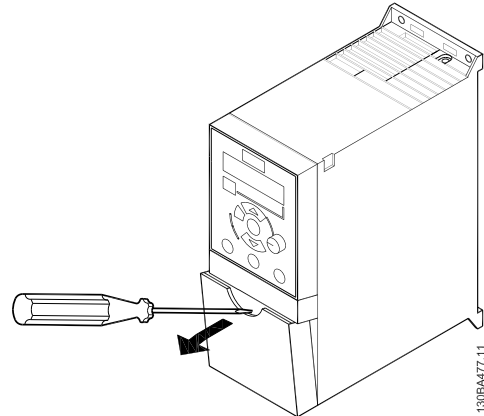

Figure 1.3 Removing Terminal Cover

Switch 1:	*OFF = PNP terminals 29 ON = NPN terminals 29
Switch 2:	*OFF = PNP terminal 18, 19, 27 and 33 ON = NPN terminal 18, 19, 27 and 33
Switch 3:	No function
Switch 4:	*OFF = Terminal 53 0-10 V ON = Terminal 53 0/4-20 mA
* = default setting	

Table 1.4 Settings for S200 Switches 1-4

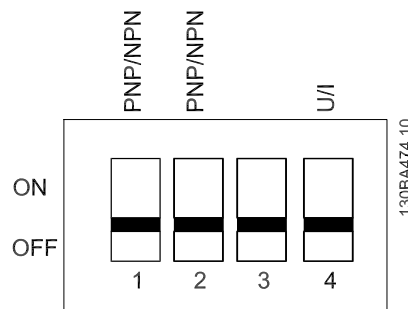

Figure 1.4 S200 Switches 1-4

Figure 1.5 shows all control terminals of the adjustable frequency drive. Applying Start (term. 18) and an analog reference (term. 53 or 60) makes the adjustable frequency drive run.

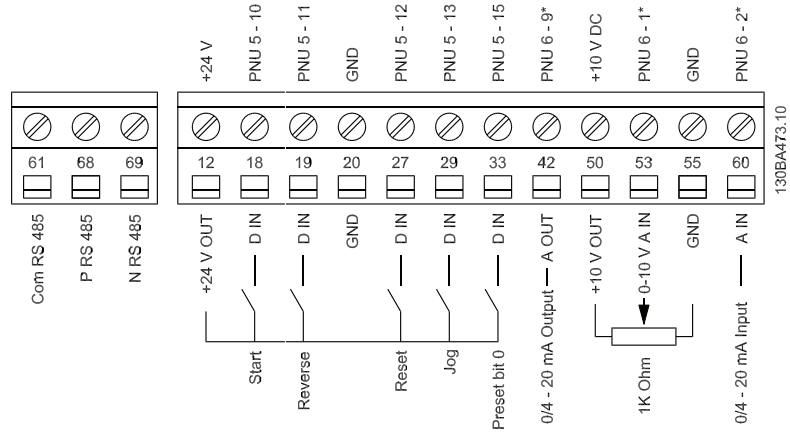

Figure 1.5 Overview of Control Terminals in PNP configuration and Factory Settings

1.3.8 Power Circuit - Overview

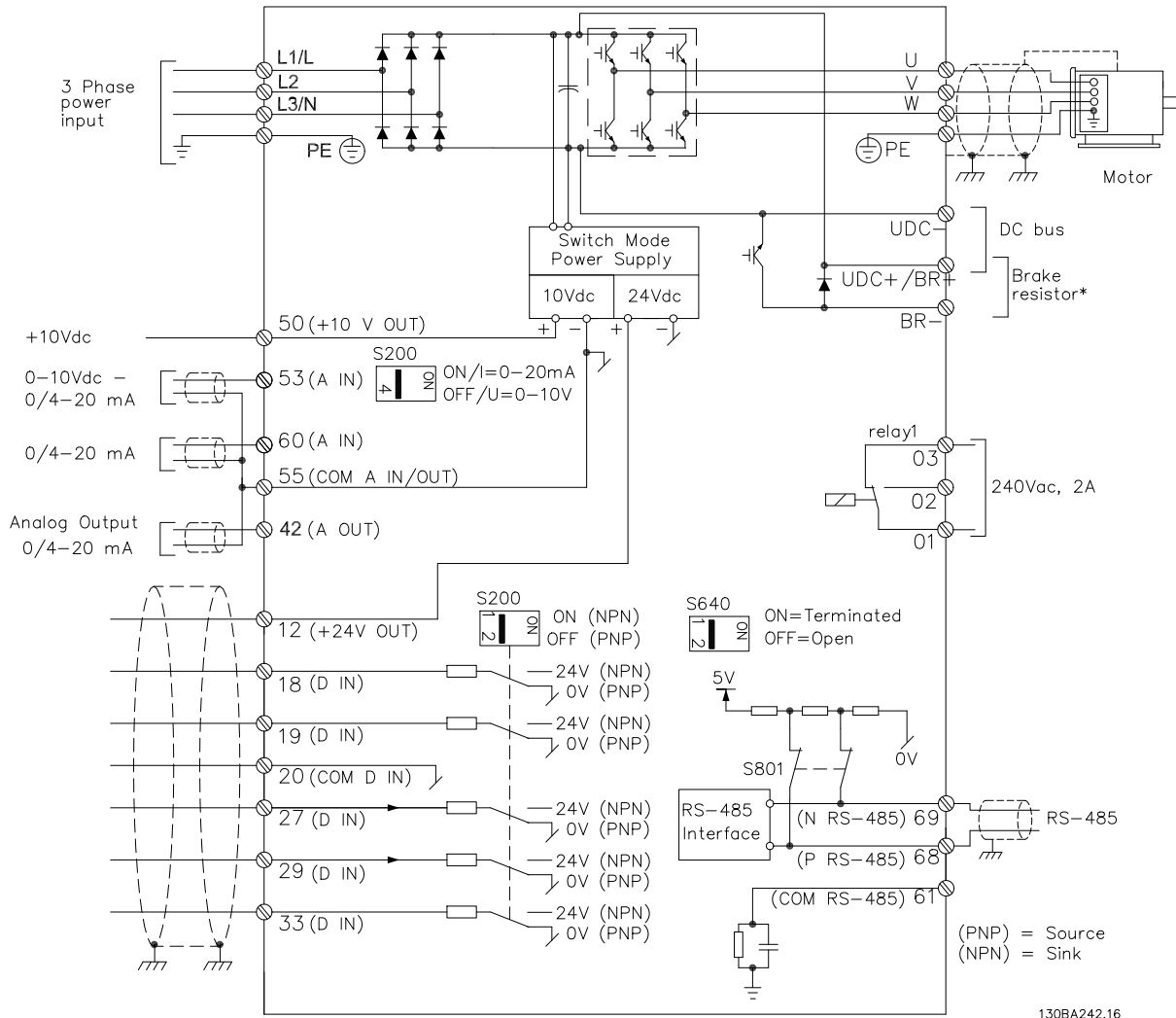

Figure 1.6 Diagram Showing all Electrical Terminals

* Brake (BR+ and BR-) are not applicable for frame M1.

Brake resistors are available from Danfoss. Improved power factor and EMC performance can be achieved by installing optional Danfoss line filters. Danfoss power filters can also be used for load sharing.

1.3.9 Load sharing/Brake

Use 0.25 in [6.3 m] insulated Faston plugs designed for high voltage for DC (load sharing and brake). Contact Danfoss or see instruction no. MI.50.Nx.02 for load sharing and instruction no. MI.90.Fx.02 for brake.

Load sharing: Connect terminals -UDC and +UDC/+BR. Brake: Connect terminals -BR and +UDC/+BR (Not applicable for frame M1).

NOTE!

Voltage levels of up to 850V DC may occur between terminals +UDC/+BR and -UDC. Not short circuit-protected.

1.4 Programming

1.4.1 Programming with LCP

For detailed information on programming, please see *Programming Guide*, MG.02.CX.YY.

The adjustable frequency drive can also be programmed from a PC via RS485 com-port by installing the MCT-10 Set-up Software.

This software can either be ordered using code number 130B1000 or downloaded from the Danfoss website: www.danfoss.com/BusinessAreas/DrivesSolutions/softwaredownload

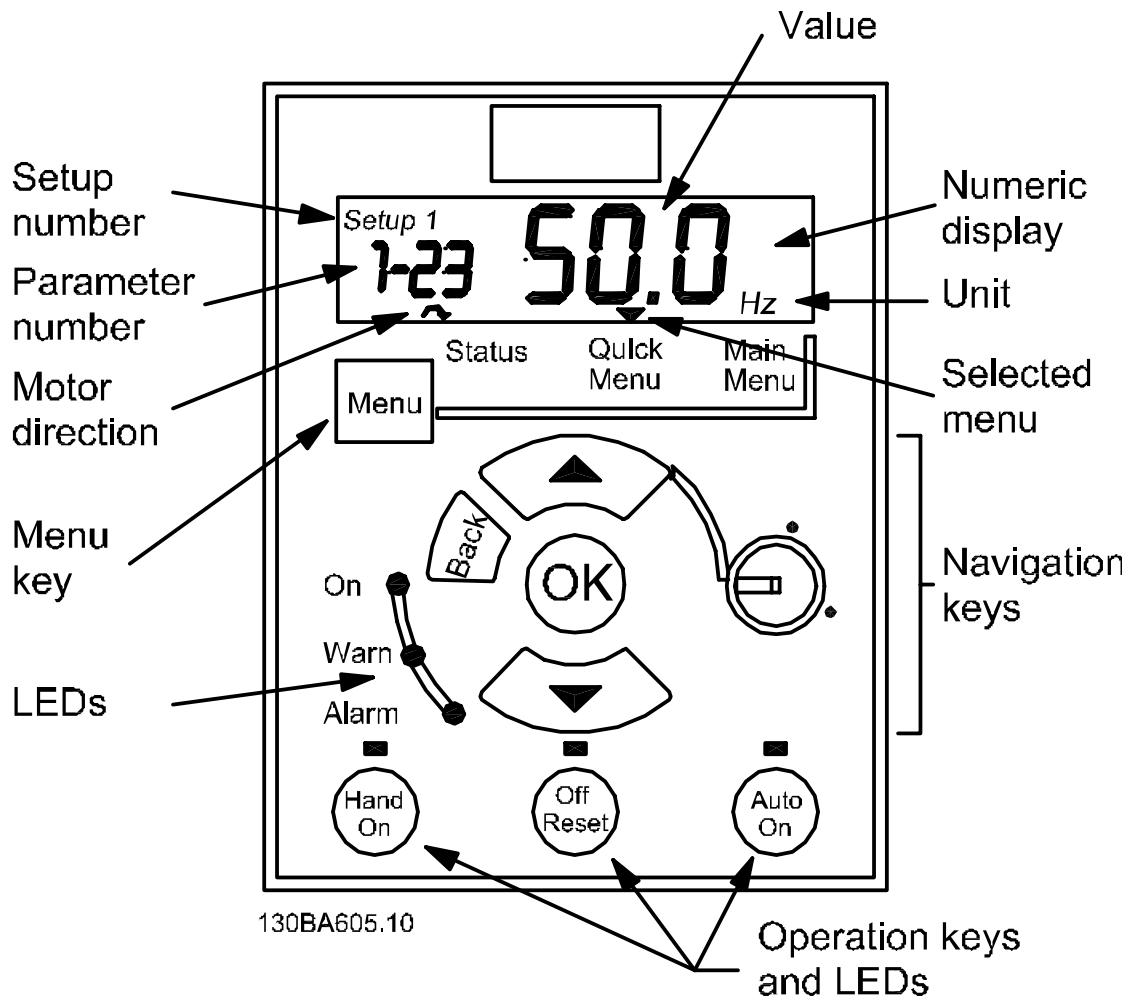

Figure 1.7 Description of LCP Buttons and Display

Use the [MENU] key to select one of the following menus:

Status:

For readouts only.

Quick Menu:

For access to Quick Menus 1 and 2, respectively.

Main Menu:

For access to all parameters.

Navigation Keys:

[Back]: For moving to the previous step or layer in the navigation structure.

Arrows [▲] [▼]: For navigating between parameter groups, parameters and within parameters.

[OK]: For selecting a parameter and for accepting changes to parameter settings.

Operation Keys:

A yellow light above the operation keys indicates the active key.

[Hand on]: Starts the motor and enables control of the adjustable frequency drive via the LCP.

[Off/Reset]: Stops the motor (off). If in alarm mode the alarm will be reset.

[Auto on]: The adjustable frequency drive is controlled either via control terminals or serial communication.

[Potentiometer] (LCP12): The potentiometer works in two ways depending on the mode in which the adjustable frequency drive is running.

In *Auto Mode*, the potentiometer acts as an extra programmable analog input.

In *Hand on Mode* the potentiometer controls local reference.

1.5 Parameter Overview

Parameter Overview			
<p>0-XX Operation/Display 0-0X Basic Settings 0-03 Regional Settings *[0] International [1] US 0-04 Oper. State at Power-up (Hand) [0] Resume *[1] Forced stop, ref = old [2] Forced stop, ref = 0 0-1X Set-up Handling 0-10 Active Set-up *[1] Set-up 1 [2] Set-up 2 [9] Multi Set-up 0-11 Edit Set-up *[1] Set-up 1 [2] Set-up 2 [9] Active Setup 0-12 Link Set-ups [0] Not Linked *[20] Linked 0-31 Custom Readout Min Scale 0.00–9999.00 * 0.00 0-32 Custom Readout Max Scale 0.00–9999.00 * 100.0 0-4X LCP Keypad 0-40 [Hand on] Key on LCP [0] Disabled *[1] Enabled 0-41 [Off / Reset] Key on LCP [0] Disable All *[1] Enable All [2] Enable Reset Only 0-42 [Auto on] Key on LCP [0] Disabled *[1] Enabled 0-5X Copy/Save 0-50 LCP Copy *[0] No copy [1] All to LCP [2] All from LCP [3] Size indep. from LCP 0-51 Set-up Copy *[0] No copy [1] Copy from setup 1 [2] Copy from setup 2 [9] Copy from Factory setup 0-6X Password 0-60 (Main) Menu Password 0–999 *0 0-61 Access to Main/Quick Menu w/o Password *[0] Full access [1] LCP:Read Only [2] LCP:No Access 1-XX Load/Motor 1-0X General Settings 1-00 Configuration Mode *[0] Speed open-loop [3] Process 1-01 Motor Control Principle [0] U/f *[1] VVC+ 1-03 Torque Characteristics *[0] Constant torque [2] Automatic Energy Optim.</p>	<p>1-05 Local Mode Configuration [0] Speed Open-loop *[2] As config in par. 1-00 1-2X Motor Data 1-20 Motor Power [kW] [HP] [1] 0.09kW/0.12HP [2] 0.12kW/0.16HP [3] 0.18kW/0.25HP [4] 0.25kW/0.33HP [5] 0.37kW/0.50HP [6] 0.55kW/0.75HP [7] 0.75kW/1.00HP [8] 1.10kW/1.50HP [9] 1.50kW/2.00HP [10] 2.20kW/3.00HP [11] 3.00kW/4.00HP [12] 3.70kW/5.00HP [13] 4.00kW/5.40HP [14] 5.50kW/7.50HP [15] 7.50kW/10.00HP [16] 11.00kW/15.00HP [17] 15.00kW/20.00HP [18] 18.50kW/25.00HP [19] 22.00kW/29.50HP [20] 30.00kW/40.00HP 1-22 Motor Voltage 50–999V * 230–400V 1-23 Motor Frequency 20–400Hz * 50Hz 1-24 Motor Current 0.01–100.00A * Motortype dep. 1-25 Motor Nominal Speed 100–9999rpm * Motortype dep. 1-29 Automatic Motor Tuning (AMT) *[0] Off [2] Enable AMT 1-3X Adv. Motor Data 1-30 Stator Resistance (Rs) [Ohm] * Dep. on motor data 1-33 Stator Leakage Reactance (X1) [Ohm] * Dep. on motor data 1-35 Main Reactance (Xh) [Ohm] * Dep. on motor data 1-5X Load Indep. Setting 1-50 Motor Magnetization at 0 Speed 0–300% * 100% 1-52 Min Speed Norm. Magnet. [Hz] 0.0–10.0Hz * 0.0Hz 1-55 U/f Characteristic - U 0–999.9V 1-56 U/f Characteristic - F 0–400Hz 1-6X Load Depen. Setting 1-60 Low Speed Load Compensation 0–199% * 100% 1-61 High Speed Load Compensation 0–199% * 100% 1-62 Slip Compensation -400–399% * 100% 1-63 Slip Compensation Time Constant 0.05–5.00s * 0.10s</p>	<p>1-7X Start Adjustments 1-71 Start Delay 0.0–10.0s * 0.0s 1-72 Start Function [0] DC hold / delay time [1] DC brake / delay time *[2] Coast / delay time 1-73 Flying Start *[0] Disabled [1] Enabled 1-8X Stop Adjustments 1-80 Function at Stop *[0] Coast [1] DC hold 1-82 Min Speed for Funct. at Stop [Hz] 0.0–20.0 Hz * 0.0 Hz 1-9X Motor Temperature 1-90 Motor Thermal Protection *[0] No protection [1] Thermistor warning [2] Thermistor trip [3] Etr warning [4] Etr trip 1-93 Thermistor Resource *[0] None [1] Analog input 53 [6] Digital input 29 2-XX Brakes 2-0XDC Brake 2-00 DC Hold Current 0–150% * 50% 2-01 DC Brake Current 0–150% * 50% 2-02 DC Braking Time 0.0–60.0s * 10.0s 2-04 DC Brake Cut-in Speed 0.0–400.0Hz * 0.0Hz 2-1X Brake Energy Funct. 2-10 Brake Function *[0] Off [1] Resistor brake [2] AC brake 2-11 Brake Resistor (ohm) 5–5000 * 5 2-16 AC Brake, Max current 0–150% * 100% 2-17 Over-voltage Control *[0] Disabled [1] Enabled (not at stop) [2] Enabled 2-2* Mechanical Brake 2-20 Release Brake Current 0.00–100.0A * 0.00A 2-22 Activate Brake Speed [Hz] 0.0–400.0Hz * 0.0Hz 3-XX Reference / Ramps 3-0X Reference Limits 3-00 Reference Range *[0] Min - Max [1] -Max - +Max 3-02 Minimum Reference -4999–4999 * 0.000 3-03 Maximum Reference -4999–4999 * 50.00 3-1X References 3-10 Preset Reference -100.0–100.0% * 0.00%</p>	<p>3-11 Jog Speed [Hz] 0.0–400.0Hz * 5.0Hz 3-12 Catch up/slow Down Value 0.00–100.0% * 0.00% 3-14 Preset Relative Reference -100.0–100.0% * 0.00 % 3-15 Reference Resource 1 [0] No function *[1] Analog Input 53 [2] Analog input 60 [8] Pulse input 33 [11] Local bus ref [21] LCP Potentiometer 3-16 Reference Resource 2 [0] No function [1] Analog Input 53 *[2] Analog input 60 [8] Pulse input 33 *[11] Local bus ref [21] LCP Potentiometer 3-17 Reference Resource 3 [0] No function [1] Analog Input 53 [2] Analog input 60 [8] Pulse input 33 *[11] Local bus ref [21] LCP Potentiometer 3-18 Relative Scaling Ref. Resource *[0] No function [1] Analog Input 53 [2] Analog input 60 [8] Pulse input 33 *[11] Local bus ref [21] LCP Potentiometer 3-4X Ramp 1 3-40 Ramp 1 Type *[0] Linear [2] Sine2 ramp 3-41 Ramp 1 Ramp up Time 0.05–3600s * 3.00s (10.00s¹) 3-42 Ramp 1 Ramp-down Time 0.05–3600s * 3.00s (10.00s¹) 3-5X Ramp 2 3-50 Ramp 2 Type *[0] Linear [2] Sine2 ramp 3-51 Ramp 2 Ramp-up Time 0.05–3600s * 3.00s (10.00 s¹) 3-52 Ramp 2 Ramp-down Time 0.05–3600s * 3.00s (10.00 s¹) 3-8X Other Ramps 3-80 Jog Ramp Time 0.05–3600s * 3.00s (10.00s¹) 3-81 Quick Stop Ramp Time 0.05–3600s * 3.00s (10.00s¹) 4-XX Limits / Warnings 4-1X Motor Limits 4-10 Motor Speed Direction [0] Clockwise [1] Counter-clockwise *[2] Both 4-12 Motor Speed Low Limit [Hz] 0.0–400.0Hz * 0.0Hz 4-14 Motor Speed High Limit [Hz] 0.1–400.0 Hz * 65.0 Hz</p>

¹⁾ M4 and M5 only

<p>4-16 Torque Limit Motor Mode 0–400% * 150%</p> <p>4-17 Torque Limit Generator Mode 0–400% * 100%</p> <p>4-5X Adj. Warnings</p> <p>4-50 Warning Current Low 0.00–100.00A * 0.00A</p> <p>4-51 Warning Current High 0.00–100.00A * 100.00A</p> <p>4-58 Missing Motor Phase Function [0] Off *[1] On</p> <p>4-6X Speed Bypass</p> <p>4-61 Bypass Speed From [Hz] 0.0–400.0Hz * 0.0Hz</p> <p>4-63 Bypass Speed To [Hz] 0.0–400.0Hz * 0.0Hz</p> <p>5-1X Digital Inputs</p> <p>5-10 Terminal 18 Digital Input [0] No function [1] Reset [2] Coast inverse [3] Coast and reset inv. [4] Quick stop inverse [5] DC brake inv. [6] Stop inv *[8] Start [9] Latched start [10] Reversing [11] Start reversing [12] Enable start forward [13] Enable start reverse [14] Jog [16–18] Preset ref bit 0-2 [19] Freeze reference [20] Freeze output [21] Speed up [22] Speed down [23] Setup select bit 0 [28] Catch up [29] Slow down [34] Ramp bit 0 [60] Counter A (up) [61] Counter A (down) [62] Reset counter A [63] Counter B (up) [64] Counter B (down) [65] ResetCounter B</p> <p>5-11 Terminal 19 Digital Input See par. 5-10. * [10] Reversing</p> <p>5-12 Terminal 27 Digital Input See par. 5-10. * [1] Reset</p> <p>5-13 Terminal 29 Digital Input See par. 5-10. * [14] Jog</p> <p>5-15 Terminal 33 Digital Input See par. 5-10. * [16] Preset ref bit 0 [26] Precise Stop Inverse [27] Start, Precise Stop [32] Pulse Input</p> <p>5-4X Relays</p> <p>5-40 Function Relay *[0] No operation [1] Control ready [2] Drive ready [3] Drive ready, Remote [4] Enable / No warning [5] Drive running [6] Running / No warning [7] Run in range / No warning [8] Run on ref / No warning [9] Alarm</p>	<p>[10] Alarm or warning [12] Out of current range [13] Below current, low [14] Above current, high [21] Thermal warning [22] Ready, No thermal warning [23] Remote ready, No thermal warning [24] Ready, Voltage ok [25] Reverse [26] Bus ok [28] Brake,NoWarn [29] Brake ready/NoFault [30] BrakeFault (IGBT) [32] Mech.brake control [36] Control word bit 11 [51] Local ref. active [52] Remote ref. active [53] No alarm [54] Start cmd active [55] Running reverse [56] Drive in hand mode [57] Drive in auto mode [60-63] Comparator 0-3 [70-73] Logic rule 0-3 [81] SL digital output B</p> <p>5-5X Pulse Input</p> <p>5-55 Terminal 33 Low Frequency 20–4999Hz * 20Hz</p> <p>5-56 Terminal 33 High Frequency 21–5000Hz * 5000Hz</p> <p>5-57 Term. 33 Low Ref./Feedb. Value -4999–4999 * 0.000</p> <p>5-58 Term. 33 High Ref./Feedb. Value -4999–4999 * 50.000</p> <p>6-XX Analog In/Out</p> <p>6-0X Analog I/O Mode</p> <p>6-00 Live Zero Timeout Time 1–99s * 10s</p> <p>6-01 Live Zero TimeoutFunction *[0] Off [1] Freeze output [2] Stop [3] Jogging [4] Max speed [5] Stop and trip</p> <p>6-1X Analog Input 1</p> <p>6-10 Terminal 53 Low Voltage 0.00–9.99V * 0.07V</p> <p>6-11 Terminal 53 High Voltage 0.01–10.00V * 10.00V</p> <p>6-12 Terminal 53 Low Current 0.00–19.99mA * 0.14mA</p> <p>6-13 Terminal 53 High Current 0.01–20.00mA * 20.00mA</p> <p>6-14 Term. 53 Low Ref./Feedb. Value -4999–4999 * 0.000</p> <p>6-15 Term. 53 High Ref./Feedb. Value -4999–4999 * 50.000</p> <p>6-16 Terminal 53 Filter Time Constant 0.01–10.00s * 0.01s</p> <p>6-19 Terminal 53 mode *[0] Voltage mode [1] Current mode</p> <p>6-2X Analog Input 2</p>	<p>6-22 Terminal 60 Low Current 0.00–19.99mA * 0.14mA</p> <p>6-23 Terminal 60 High Current 0.01–20.00mA * 20.00mA</p> <p>6-24 Term. 60 Low Ref./Feedb. Value -4999–4999 * 0.000</p> <p>6-25 Term. 60 High Ref./Feedb. Value -4999–4999 * 50.00</p> <p>6-26 Terminal 60 Filter Time Constant 0.01–10.00s * 0.01s</p> <p>6-8X LCP potentiometer</p> <p>6-80 LCP Potmeter Enable [0] Disabled *[1] Enable</p> <p>6-81 LCP potm. Low Reference -4999–4999 * 0.000</p> <p>6-82 LCP potm. High Reference -4999–4999 * 50.00</p> <p>6-9X Analog Output xx</p> <p>6-90 Terminal 42 Mode *[0] 0-20mA [1] 4-20mA [2] Digital Output</p> <p>6-91 Terminal 42 Analog Output *[0] No operation [10] Output Frequency [11] Reference [12] Feedback [13] Motor Current [16] Power [20] Bus Reference</p> <p>6-92 Terminal 42 Digital Output See par. 5-40 *[0] No Operation [80] SL Digital Output A</p> <p>6-93 Terminal 42 Output Min Scale 0.00–200.0% * 0.00%</p> <p>6-94 Terminal 42 Output Max Scale 0.00–200.0% * 100.0%</p> <p>7-XX Controllers</p> <p>7-2X Process Ctrl. Feedb</p> <p>7-20 Process CL Feedback 1 Resource *[0] NoFunction [1] Analog Input 53 [2] Analog input 60 [8] PulseInput33 [11] LocalBusRef</p> <p>7-3X Process PI Ctrl. 7-30 Process PI Normal/ Inverse Ctrl *[0] Normal [1] Inverse</p> <p>7-31 Process PI Anti-windup [0] Disable *[1] Enable</p> <p>7-32 Process PI Start Speed 0.0–200.0Hz * 0.0Hz</p> <p>7-33 Process PI Proportional Gain 0.00–10.00 * 0.01</p> <p>7-34 Process PI Integral Time 0.10–9999s * 9999s</p> <p>7-38 Process PI Feed Forward Factor 0–400% * 0%</p> <p>7-39 On Reference Bandwidth 0–200% * 5%</p> <p>8-XX Comm. and Options</p> <p>8-0X General Settings</p>	<p>8-01 Control Site *[0] Digital and ControlWord [1] Digital only [2] ControlWord only</p> <p>8-02 Control Word Source [0] None *[1] FC RS485</p> <p>8-03 Control Word Timeout Time 0.1–6500s * 1.0s</p> <p>8-04 Control Word Timeout Function *[0] Off [1] Freeze Output [2] Stop [3] Jogging [4] Max. Speed [5] Stop and trip</p> <p>8-06 Reset Control Word Timeout *[0] No Function [1] Do reset</p> <p>8-3X FC Port Settings</p> <p>8-30 Protocol *[0] FC [2] Modbus</p> <p>8-31 Address 1–247 * 1</p> <p>8-32 FC Port Baud Rate [0] 2400 Baud [1] 4800 Baud *[2] 9600 Baud For choose FC Bus in 8-30 *[3] 19200 Baud For choose Modbus in 8-30 [4] 38400 Baud</p> <p>8-33 FC Port Parity *[0] Even Parity, 1 Stop Bit [1] Odd Parity, 1 Stop Bit [2] No Parity, 1 Stop Bit [3] No Parity, 2 Stop Bits</p> <p>8-35 Minimum Response Delay 0.001–0.5 * 0.010s</p> <p>8-36 Max Response Delay 0.100–10.00s * 5.000s</p> <p>8-4X FC MC protocol set</p> <p>8-43 FC Port PCD Read Configuration *[0] None Expressionlimit [1] [1500] Operation Hours [2] [1501] Running Hours [3] [1502] kWh Counter [4] [1600] Control Word [5] [1601] Reference [Unit] [6] [1602] Reference % [7] [1603] Status Word [8] [1605] Main Actual Value [%] [9] [1609] Custom Readout [10] [1610] Power [kW] [11] [1611] Power [hp] [12] [1612] Motor Voltage [13] [1613] Frequency [14] [1614] Motor Current [15] [1615] Frequency [%] [16] [1618] Motor Thermal [17] [1630] DC Link Voltage [18] [1634] Heatsink Temp. [19] [1635] Inverter Thermal [20] [1638] SL Controller State [21] [1650] External Reference [22] [1651] Pulse Reference [23] [1652] Feedback [Unit] [24] [1660] Digital Input 18,19,27,33 [25] [1661] Digital Input 29 [26] [1662] Analog Input 53(V) [27] [1663] Analog Input 53(mA)</p>
--	--	--	--

<p>[28] [1664] Analog Input 60 [29] [1665] Analog Output 42 [mA] [30] [1668] Freq. Input 33 [Hz] [31] [1671] Relay Output [bin] [32] [1672] Counter A [33] [1673] Counter B [34] [1690] Alarm Word [35] [1692] Warning Word [36] [1694] Ext. Status Word 8-5X Digital/Bus 8-50 Coasting Select [0] DigitalInput [1] Bus [2] LogicAnd *[3] LogicOr 8-51 Quick Stop Select See par. 8-50 * [3] LogicOr 8-52 DC Brake Select See par. 8-50 * [3] LogicOr 8-53 Start Select See par. 8-50 * [3] LogicOr 8-54 Reversing Select See par. 8-50 * [3] LogicOr 8-55 Set-up Select See par. 8-50 * [3] LogicOr 8-56 Preset Reference Select See par. 8-50 * [3] LogicOr 8-9X Bus Jog / Feedback 8-94 Bus feedback 1 0x8000-0x7FFF * 0 13-XX Smart Logic 13-0X SLC Settings 13-00 SL Controller Mode *[0] Off [1] On 13-01 Start Event [0] False [1] True [2] Running [3] InRange [4] OnReference [7] OutOfCurrentRange [8] BelowLow [9] AboveHigh [16] ThermalWarning [17] MainOutOfRange [18] Reversing [19] Warning [20] Alarm_Trip [21] Alarm_TripLock [22-25] Comparator 0-3 [26-29] LogicRule0-3 [33] DigitalInput_18 [34] DigitalInput_19 [35] DigitalInput_27 [36] DigitalInput_29 [38] DigitalInput_33 *[39] StartCommand [40] DriveStopped 13-02 Stop Event See par. 13-01 * [40] DriveStopped 13-03 Reset SLC *[0] Do not reset [1] Reset SLC 13-1X Comparators</p>	<p>13-10 Comparator Operand *[0] Disabled [1] Reference [2] Feedback [3] MotorSpeed [4] MotorCurrent [6] MotorPower [7] MotorVoltage [8] DCLinkVoltage [12] AnalogInput53 [13] AnalogInput60 [18] PulseInput33 [20] AlarmNumber [30] CounterA [31] CounterB 13-11 Comparator Operator [0] Less Than *[1] Approximately equals [2] Greater Than 13-12 Comparator Value -9999-9999 * 0.0 13-2X Timers 13-20 SL Controller Timer 0.0-3600 s * 0.0 s 13-4X Logic Rules 13-40 Logic Rule Boolean 1 See par. 13-01 * [0] False [30] - [32] SL Timeout 0-2 13-41 Logic Rule Operator 1 *[0] Disabled [1] And [2] Or [3] And not [4] Or not [5] Not and [6] Not or [7] Not and not [8] Not or not 13-42 Logic Rule Boolean 2 See par. 13-40 * [0] False 13-43 Logic Rule Operator 2 See par. 13-41 * [0] Disabled 13-44 Logic Rule Boolean 3 See par. 13-40 * [0] False 13-5X States 13-51 SL Controller Event See par. 13-40 * [0] False 13-52 SL Controller Action *[0] Disabled [1] NoAction [2] SelectSetup1 [3] SelectSetup2 [10-17] SelectPresetRef0-7 [18] SelectRamp1 [19] SelectRamp2 [22] Run [23] RunReverse [24] Stop [25] Ostop [26] DCstop [27] Coast [28] FreezeOutput [29] StartTimer0 [30] StartTimer1 [31] StartTimer2 [32] Set Digital Output A Low</p>	<p>[33] Set Digital Output B Low [38] Set Digital Output A High [39] Set Digital Output B High [60] ResetCounterA [61] ResetCounterB 14-XX Special Functions 14-0X Inverter Switching 14-01 Switching Frequency [0] 2 kHz *[1] 4 kHz [2] 8 kHz [4] 16 kHz not available for M5 14-03 Overmodulation [0] Off *[1] On 14-1X Line power monitoring 14-12 Function at line imbalance *[0] Trip [1] Warning [2] Disabled 14-2X Trip Reset 14-20 Reset Mode *[0] Manual reset [1-9] AutoReset 1-9 [10] AutoReset 10 [11] AutoReset 15 [12] AutoReset 20 [13] Infinite auto reset 14-21 Automatic Restart Time 0-600s * 10s 14-22 Operation Mode *[0] Normal Operation [2] Initialization 14-26 Action At Inverter Fault *[0] Trip [1] Warning 14-4X Energy Optimizing 14-41 AEO Minimum Magnetization 40-75% * 66% 15-XX Drive Information 15-0X Operating Data 15-00 Operating Days 15-01 Running Hours 15-02 kWh Counter 15-03 Power Ups 15-04 Over Temps 15-05 Over Volts 15-06 Reset kWh Counter *[0] Do not reset [1] Reset counter 15-07 Reset Running Hours Counter *[0] Do not reset [1] Reset counter 15-3X Fault Log 15-30 Fault Log: Error Code 15-4X Drive Identification 15-40 FC Type 15-41 Power Section 15-42 Voltage 15-43 Software Version 15-46 Adjustable Frequency Drive Order. No 15-48 LCP ID No</p>	<p>15-51 Adjustable Frequency Drive Serial No 16-XX Data Readouts 16-0X General Status 16-00 Control Word 0-0XFFFF 16-01 Reference [Unit] -4999-4999 * 0.000 16-02 Reference % -200.0-200.0% * 0.0% 16-03 Status Word 0-0XFFFF 16-05 Main Actual Value [%] -200.0-200.0% * 0.0% 16-09 Custom Readout Dep. on par. 0-31, 0-32 and 4-14 16-1X Motor Status 16-10 Power [kW] 16-11 Power [hp] 16-12 Motor Voltage [V] 16-13 Frequency [Hz] 16-14 Motor Current [A] 16-15 Frequency [%] 16-18 Motor Thermal [%] 16-3X Drive Status 16-30 DC Link Voltage 16-34 Heatsink Temp. 16-35 Inverter Thermal 16-36 Inv.Nom. Current 16-37 Inv. Max. Current 16-38 SL Controller State 16-5X Ref. / Feedb. 16-50 External Reference 16-51 Pulse Reference 16-52 Feedback [Unit] 16-6X Inputs / Outputs 16-60 Digital Input 18,19,27,33 0-1111 16-61 Digital Input 29 0-1 16-62 Analog Input 53 (volt) 16-63 Analog Input 53 (current) 16-64 Analog Input 60 16-65 Analog Output 42 [mA] 16-68 Pulse Input [Hz] 16-71 Relay Output [bin] 16-72 Counter A 16-73 Counter B 16-8X Fieldbus / FC Port 16-86 FC Port REF 1 0x8000-0x7FFF 16-9X Diagnosis Readouts 16-90 Alarm Word 0-0XFFFFFFFF 16-92 Warning Word 0-0XFFFFFFFF 16-94 Ext. Status Word 0-0XFFFFFFFF 18-XX Extended Motor Data 18-8X Motor Resistors 18-80 Stator Resistance (High resolution) 0.000-99.990ohm * 0.000ohm 18-81 Stator Leakage Reactance (High resolution) 0.000-99.990ohm * 0.000ohm</p>
--	---	--	--

1.6 Troubleshooting

No.	Description	Warning	Alarm	Trip Lock	Error	Cause of Problem
2	Live zero error	X	X			Signal on terminal 53 or 60 is less than 50% of the value set in par. 6-10, 6-12 and 6-22.
4	Line phase loss ¹⁾	X	X	X		Missing phase on the supply side, or a voltage imbalance that is too high. Check supply voltage.
7	DC overvoltage ¹⁾	X	X			Intermediate circuit voltage exceeds the limit.
8	DC undervoltage ¹⁾	X	X			Intermediate circuit voltage drops below the "voltage warning low" limit.
9	Inverter overloaded	X	X			More than 100% load for too long.
10	Motor ETR over temperature	X	X			Motor is too hot due to more than 100% load for too long.
11	Motor thermistor over temperature	X	X			The thermistor or the thermistor connection is disconnected.
12	Torque limit	X				Torque exceeds the value set in either par. 4-16 or 4-17.
13	Overcurrent	X	X	X		Inverter peak current limit is exceeded.
14	Ground fault		X	X		Discharge from output phases to ground.
16	Short Circuit		X	X		Short-circuit in the motor or on the motor terminals.
17	Control word timeout	X	X			No communication to the adjustable frequency drive.
25	Brake resistor short-circuited		X	X		Brake resistor is short-circuited, thus the brake function is disconnected.
27	Brake chopper short-circuited		X	X		Brake transistor is short-circuited, thus the brake function is disconnected.
28	Brake check		X			Brake resistor is not connected/working
29	Power board overtemp	X	X	X		Heatsink cut-out temperature has been reached.
30	Motor phase U missing		X	X		Motor phase U is missing. Check the phase.
31	Motor phase V missing		X	X		Motor phase V is missing. Check the phase.
32	Motor phase W missing		X	X		Motor phase W is missing. Check the phase.
38	Internal fault		X	X		Contact local Danfoss supplier.
44	Ground fault		X	X		Discharge from output phases to ground.
47	Control Voltage Fault		X	X		24 V DC may be overloaded.
51	AMT check U_{nom} and I_{nom}		X			Wrong setting for motor voltage and/or motor current.
52	AMT low I_{nom}		X			Motor current is too low. Check settings.
59	Current limit	X				VLT overload.
63	Mechanical Brake Low		X			Actual motor current has not exceeded the "release brake" current in the "start delay" time window.
80	Drive Initialized to Default Value		X			All parameter settings are initialized to default settings.
84	The connection between drive and LCP is lost.				X	No communication between LCP and adjustable frequency drive.
85	Button disabled				X	See parameter group 0-4* LCP
86	Copy fail				X	An error occurred while copying from adjustable frequency drive to LCP or vice versa.
87	LCP data invalid				X	Occurs when copying from LCP if the LCP contains erroneous data - or if no data was uploaded to the LCP.
88	LCP data not compatible				X	Occurs when copying from LCP if data are moved between adjustable frequency drives with major differences in software versions.
89	Parameter read-only				X	Occurs when trying to write to a read-only parameter.
90	Parameter database busy				X	LCP and RS485 connection are trying to update parameters simultaneously.
91	Parameter value is not valid in this mode				X	Occurs when trying to write an illegal value to a parameter.
92	Parameter value exceeds the min/max limits				X	Occurs when trying to set a value outside the range.
nw run	Not While RUNning				X	Parameter can only be changed when the motor is stopped.
Err.	An incorrect password was entered				X	Occurs when using an incorrect password for changing a password-protected parameter.

¹⁾ These faults may be caused by line power distortions. Installing a Danfoss line filter may rectify this problem.

Table 1.5 Warnings and AlarmsCode list

1.7 Specifications

1.7.1 Line Power Supply 3 x 200–240V AC

Normal overload 150% for 1 minute							
Adjustable frequency drive		PK18	PK37	PK75	P1K5	P2K2	
Typical Shaft Output [kW]		0.18	0.37	0.75	1.5	2.2	
Typical Shaft Output [HP]		0.25	0.5	1	2	3	
IP 20		Frame M1	Frame M1	Frame M1	Frame M2	Frame M3	
Output current							
	Continuous (3 x 200–240V) [A]	1.2	2.2	4.2	6.8	9.6	
	Intermittent (3 x 200–240V) [A]	1.8	3.3	6.3	10.2	14.4	
	Max. cable size:						
	(line power, motor) [mm ² /AWG]	4/10					
Max. input current							
	Continuous (3 x 200–240V) [A]	3.3	6.1	11.6	18.7	26.4	
	Intermittent (3 x 200–240V) [A]	4.5	8.3	15.6	26.4	37.0	
	Max. electrical fuses [A]	See section Fuses.					
	Environment						
	Estimated power loss [W], Best case/ Typical ¹⁾	12.5/ 15.5	20.0/ 25.0	36.5/ 44.0	61.0/ 67.0	81.0/ 85.1	
Weight enclosure IP20 (lbs [kg])	2.43 [1.1]	2.43 [1.1]	2.43 [1.1]	3.53 [1.6]	6.61 [3.0]		
Efficiency [%], Best case/Typical ¹⁾	95.6/ 94.5	96.5/ 95.6	96.6/ 96.0	97.0/ 96.7	96.9/ 97.1		

Table 1.6 Line Power Supply 3 x 200–240V AC

1. At rated load conditions.

1.7.2 Line Power Supply 3 x 200–240V AC

Normal overload 150% for 1 minute								
Adjustable frequency drive		PK25	PK37	PK75	P1K5	P2K2	P3K7	
Typical Shaft Output [kW]		0.25	0.37	0.75	1.5	2.2	3.7	
Typical Shaft Output [HP]		0.33	0.5	1	2	3	5	
IP 20		Frame M1	Frame M1	Frame M1	Frame M2	Frame M3	Frame M3	
Output current								
	Continuous (3 x 200–240V) [A]	1.5	2.2	4.2	6.8	9.6	15.2	
	Intermittent (3 x 200–240V) [A]	2.3	3.3	6.3	10.2	14.4	22.8	
	Max. cable size:							
	(line power, motor) [mm ² /AWG]	4/10						
Max. input current								
	Continuous (3 x 200–240V) [A]	2.4	3.5	6.7	10.9	15.4	24.3	
	Intermittent (3 x 200–240V) [A]	3.2	4.6	8.3	14.4	23.4	35.3	
	Max. electrical fuses [A]	See section Fuses.						
	Environment							
	Estimated power loss [W], Best case/ Typical ¹⁾	14.0/ 20.0	19.0/ 24.0	31.5/ 39.5	51.0/ 57.0	72.0/ 77.1	115.0/ 122.8	
Weight enclosure IP20 (lbs [kg])	2.43 [1.1]	2.43 [1.1]	2.43 [1.1]	3.53 [1.6]	6.61 [3.0]	6.61 [3.0]		
Efficiency [%], Best case/Typical ¹⁾	96.4/ 94.9	96.7/ 95.8	97.1/ 96.3	97.4/ 97.2	97.2/ 97.4	97.3/ 97.4		

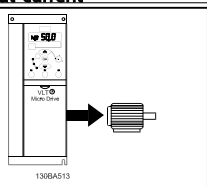
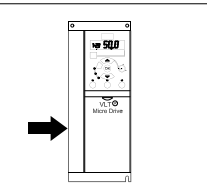
Table 1.7 Line Power Supply 3 x 200–240V AC

1. At rated load conditions.

1.7.3 Line Power Supply 3 x 380–480V AC

Normal overload 150% for 1 minute								
Adjustable frequency drive	PK37	PK75	P1K5	P2K2	P3K0	P4K0		
Typical Shaft Output [kW]	0.37	0.75	1.5	2.2	3.0	4.0		
Typical Shaft Output [HP]	0.5	1	2	3	4	5		
IP 20	Frame M1	Frame M1	Frame M2	Frame M2	Frame M3	Frame M3		
Output current								
	Continuous (3 x 380–440V) [A]	1.2	2.2	3.7	5.3	7.2	9.0	
	Intermittent (3 x 380–440V) [A]	1.8	3.3	5.6	8.0	10.8	13.7	
	Continuous (3 x 440–480V) [A]	1.1	2.1	3.4	4.8	6.3	8.2	
	Intermittent (3 x 440–480V) [A]	1.7	3.2	5.1	7.2	9.5	12.3	
	Max. cable size: (line power, motor) [mm ² / AWG]	4/10						
Max. input current								
	Continuous (3 x 380–440V) [A]	1.9	3.5	5.9	8.5	11.5	14.4	
	Intermittent (3 x 380–440V) [A]	2.6	4.7	8.7	12.6	16.8	20.2	
	Continuous (3 x 440–480V) [A]	1.7	3.0	5.1	7.3	9.9	12.4	
	Intermittent (3 x 440–480V) [A]	2.3	4.0	7.5	10.8	14.4	17.5	
	Max. electrical fuses [A]	See section Fuses.						
	Environment							
	Estimated power loss [W], Best case/ Typical ¹⁾	18.5/ 25.5	28.5/ 43.5	41.5/ 56.5	57.5/ 81.5	75.0/ 101.6	98.5/ 133.5	
	Weight enclosure IP20 (lbs [kg])	2.43 [1.1]	2.43 [1.1]	3.53 [1.6]	3.53 [1.6]	6.61 [3.0]	6.61 [3.0]	
Efficiency [%], Best case/ Typical ¹⁾	96.8/ 95.5	97.4/ 96.0	98.0/ 97.2	97.9/ 97.1	98.0/ 97.2	98.0/ 97.3		

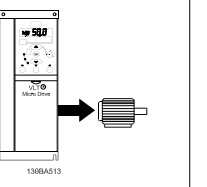
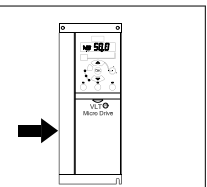
Table 1.8 Line Power Supply 3 x 380–480V AC

1. At rated load conditions.

Normal overload 150% for 1 minute								
Adjustable frequency drive	P5K5	P7K5	P11K	P15K	P18K	P22K		
Typical Shaft Output [kW]	5.5	7.5	11	15	18.5	22		
Typical Shaft Output [HP]	7.5	10	15	20	25	30		
IP 20	Frame M3	Frame M3	Frame M4	Frame M4	Frame M5	Frame M5		
Output current								
	Continuous (3 x 380–440V) [A]	12.0	15.5	23.0	31.0	37.0	43.0	
	Intermittent (3 x 380–440V) [A]	18.0	23.5	34.5	46.5	55.5	64.5	
	Continuous (3 x 440–480V) [A]	11.0	14.0	21.0	27.0	34.0	40.0	
	Intermittent (3 x 440–480V) [A]	16.5	21.3	31.5	40.5	51.0	60.0	
	Max. cable size:							
	(line power, motor) [mm ² / AWG]	4/10		16/6				
Max. input current								
	Continuous (3 x 380–440V) [A]	19.2	24.8	33.0	42.0	34.7	41.2	
	Intermittent (3 x 380–440V) [A]	27.4	36.3	47.5	60.0	49.0	57.6	
	Continuous (3 x 440–480V) [A]	16.6	21.4	29.0	36.0	31.5	37.5	
	Intermittent (3 x 440–480V) [A]	23.6	30.1	41.0	52.0	44.0	53.0	
	Max. electrical fuses [A]	See section Fuses.						
	Environment							
Estimated power loss [W], Best case/ Typical ¹⁾	131.0/ 166.8	175.0/ 217.5	290.0/ 342.0	387.0/ 454.0	395.0/ 428.0	467.0/ 520.0		
Weight enclosure IP20 (lbs [kg])	6.61 [3.0]	6.61 [3.0]						
Efficiency [%], Best case/ Typical ¹⁾	98.0/ 97.5	98.0/ 97.5	97.8/ 97.4	97.7/ 97.4	98.1/ 98.0	98.1/ 97.9		

Table 1.9 Line Power Supply 3 x 380–480V AC

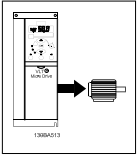
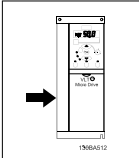
1. At rated load conditions.

1.8 General Technical Data

Protection and features

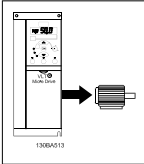
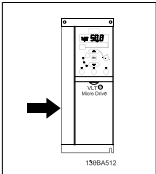
- Electronic thermal motor protection against overload.
- Temperature monitoring of the heatsink ensures that the Adjustable frequency drive trips in case of overtemperature.
- The Adjustable frequency drive is protected against short-circuits between motor terminals U, V, W.
- If a motor phase is missing, the Adjustable frequency drive trips and issues an alarm.
- If a line phase is missing, the Adjustable frequency drive trips or issues a warning (depending on the load).
- Monitoring of the intermediate circuit voltage ensures that the Adjustable frequency drive trips if the intermediate circuit voltage is too low or too high.
- The Adjustable frequency drive is protected against ground faults on motor terminals U, V, W.

Line power supply (L1/L, L2, L3/N):

Supply voltage	200–240V ±10%
Supply voltage	380–480V ±10%
Supply frequency	50/60Hz
Max. imbalance temporary between line phases	3.0% of rated supply voltage
True Power Factor (λ)	≥ 0.4 nominal at rated load
Displacement Power Factor ($\cos\phi$) near unity	(> 0.98)
Switching on input supply L1/L, L2, L3/N (power-ups)	maximum 2 times/min.
Environment according to EN60664-1	overvoltage category III/pollution degree 2

The unit is suitable for use on a circuit capable of delivering not more than 100,000 RMS symmetrical Amperes, 240/480V maximum.

Motor output (U, V, W):

Output voltage	0–100% of supply voltage
Output frequency	0–200Hz (VVC+), 0–400Hz (u/f)
Switching on output	Unlimited
Ramp times	0.05–3600sec.
Cable lengths and cross-sections:	
Max. motor cable length, shielded/armored (EMC-compliant installation)	50 ft [15 m]
Max. motor cable length, unshielded/unarmored	164 ft [50 m]
Max. cross-section to motor, line power*	
Connection to load sharing/brake (M1, M2, M3)	0.25 in [6.3 mm] insulated Faston plugs
Max. cross-section to load sharing/brake (M4, M5)	16mm ² /6AWG
Maximum cross-section to control terminals, rigid wire	1.5mm ² /16 AWG (2 x 0.75mm ²)
Maximum cross-section to control terminals, flexible cable	1mm ² /18 AWG
Maximum cross-section to control terminals, cable with enclosed core	0.5mm ² /20AWG
Minimum cross-section to control terminals	0.25mm ²

** See tables for line power supply for more information!*

Digital Inputs (Pulse/Encoder Inputs):

Programmable digital inputs (pulse/encoder)	5 (1)
Terminal number	18, 19, 27, 29, 33,
Logic	PNP or NPN
Voltage level	0–24V DC
Voltage level, logic '0' PNP	< 5V DC
Voltage level, logic '1' PNP	> 10V DC
Voltage level, logic '0' NPN	> 19V DC
Voltage level, logic '1' NPN	< 14V DC
Maximum voltage on input	28V DC

Input resistance, R_i	approx. 4k
Max. pulse frequency at terminal 33	5000Hz
Min. pulse frequency at terminal 33	20Hz
Analog Inputs:	
Number of analog inputs	2
Terminal number	53, 60
Voltage mode (Terminal 53)	Switch S200=OFF(U)
Current mode (Terminal 53 and 60)	Switch S200=ON(I)
Voltage level	0–10V
Input resistance, R_i	approx. 10 k Ω
Max. voltage	20V
Current level	0/4 to 20 mA (scaleable)
Input resistance, R_i	approx. 200 Ω
Max. current	30mA

Analog output:

Number of programmable analog outputs	1
Terminal number	42
Current range at analog output	0/4–20mA
Max. load to common at analog output	500 Ω
Max. voltage at analog output	17V
Accuracy on analog output	Max. error: 0.8% of full scale
Resolution on analog output	8bit

Control card, RS-485 serial communication:

Terminal number	68 (P,TX+, RX+), 69 (N,TX-, RX-)
Terminal number 61	Common for terminals 68 and 69

Control card, 24 V DC output:

Terminal number	12
Max. load (M1 and M2)	160mA
Max. load (M3)	30mA
Max. load (M4 and M5)	200mA

Relay output:

Programmable relay output	1
Relay 01 Terminal number	01-03 (break), 01-02 (make)
Max. terminal load (AC-1)1) on 01-02 (NO) (resistive load)	250V AC, 2 A
Max. terminal load (AC-15) ¹⁾ on 01-02 (NO) (Inductive load @ $\cos\phi$ 0.4)	250V AC, 0.2 A
Max. terminal load (DC-1)1) on 01-02 (NO) (resistive load)	30V DC, 2 A
Max. terminal load (DC-13)1) on 01-02 (NO) (inductive load)	24 V DC, 0.1A
Max. terminal load (AC-1)1) on 01-03 (NC) (resistive load)	250V AC, 2 A
Max. terminal load (AC-15) ¹⁾ on 01-03 (NC) (Inductive load @ $\cos\phi$ 0.4)	250V AC, 0.2A
Max. terminal load (DC-1)1) on 01-03 (NC) (resistive load)	30V DC, 2 A
Min. terminal load on 01-03 (NC), 01-02 (NO)	24V DC 10 mA, 24V AC 20 mA
Environment according to EN 60664-1	overvoltage category III/pollution degree 2

1) IEC 60947 part 4 and 5

Control card, 10 V DC output:

Terminal number	50
Output voltage	10.5V \pm 0.5V
Max. load	25mA

NOTE!

All inputs, outputs, circuits, DC supplies and relay contacts are galvanically isolated from the supply voltage (PELV) and other high-voltage terminals.

Surroundings:

Enclosure	IP 20
Enclosure kit available.	IP 21, TYPE 1
Vibration test	1.0 g
Max. relative humidity	5%-95% (IEC 60721-3-3; Class 3K3 (non-condensing) during operation
Aggressive environment (IEC 60721-3-3), coated	class 3C3
Test method according to IEC 60068-2-43 H2S (10 days)	
Ambient temperature	Max. 104°F [40°C]
<i>Derating for high ambient temperature, see section on special conditions</i>	
Minimum ambient temperature during full-scale operation	32°F [0°C]
Minimum ambient temperature at reduced performance	14°F [-10°C]
Temperature during storage/transport	-13°--+149°/158°F [-25°--+65°/70°C]
Maximum altitude above sea level without derating	3280 ft [1000 m]
Maximum altitude above sea level with derating	9842 ft [3000 m]
<i>Derating for high altitude, see section on special conditions</i>	
Safety standards	EN/IEC 61800-5-1, UL 508C
EMC standards, Emission	EN 61800-3, EN 61000-6-3/4, EN 55011, IEC 61800-3 EN 61800-3, EN 61000-6-1/2, EN 61000-4-2, EN 61000-4-3,
EMC standards, Immunity	EN 61000-4-4, EN 61000-4-5, EN 61000-4-6

See section on special conditions

1.9 Special Conditions

1.9.1 Derating for Ambient Temperature

The ambient temperature measured over 24 hours should be at least 41°F [5°C] lower than the max. ambient temperature.

If the adjustable frequency drive is operated at a high ambient temperature, the continuous output current should be decreased.

The adjustable frequency drive has been designed for operation at max 122°F [50°C] ambient temperature with one motor size smaller than nominal. Continuous operation at full load at 122°F [50°C] ambient temperature will reduce the lifetime of the adjustable frequency drive.

1.9.2 Derating for Low Air Pressure

The cooling capability of air is decreased at low air pressure.

For altitudes above 6561 ft [2 km], please contact Danfoss regarding PELV.

Below altitudes of 3,281 ft [1,000 m], no derating is necessary, but at 3,281 ft [1,000 m] and higher, the ambient temperature or maximum output current should be decreased.

Decrease the output by 1% per 328 ft [100 m] higher than an altitude of 3,281 ft [1,000 m], or reduce the max. ambient temperature by 1 degree per 656 ft [200 m].

1.9.3 Derating for Running at Low Speeds

When a motor is connected to an adjustable frequency drive, it is necessary to make sure that the cooling of the motor is adequate.

A problem may occur at low speeds in constant torque applications. Running continuously at low speeds – below half the nominal motor speed – may require additional air cooling. Alternatively, choose a larger motor (one size up).

1.10 Options for VLT® Micro Drive FC 51

Ordering No	Description
132B0100	VLT Control Panel LCP 11 w/o potentiometer
132B0101	VLT Control Panel LCP 12 with potentiometer
132B0102	Remote Mounting Kit for LCP incl. 10 ft [3 m] cable IP55 with LCP 11, IP21 with LCP 12
132B0103	Nema Type 1 kit for M1 frame
132B0104	Type 1 kit for M2 frame
132B0105	Type 1 kit for M3 frame
132B0106	De-coupling plate kit for M1 and M2 frames
132B0107	De-coupling plate kit for M3 frame
132B0108	IP21 for M1 frame
132B0109	IP21 for M2 frame
132B0110	IP21 for M3 frame
132B0111	DIN rail mounting kit for M1 and M2 frames
132B0120	Type 1 kit for M4 frame
132B0121	Type 1 kit for M5 frame
132B0122	De-coupling plate kit for M4 and M5 frames
132b0126	M1 frame spare parts kits
132b0127	M2 frame spare parts kits
132b0128	M3 frame spare parts kits
132b0129	M4 frame spare parts kits
132b0130	M5 frame spare parts kits

Danfoss line filters and brake resistors are available upon request.



www.danfoss.com/drives

Danfoss shall not be responsible for any errors in catalogs, brochures or other printed material. Danfoss reserves the right to alter its products at any time without notice, provided that alterations to products already on order shall not require material changes in specifications previously agreed upon by Danfoss and the Purchaser. All trademarks in this material are property of the respective companies. Danfoss and the Danfoss logotype are trademarks of Danfoss A/S. All rights reserved.

Danfoss Drives

4401 N. Bell School Rd.
Loves Park IL 61111 USA
Phone: 1-800-432-6367
1-815-639-8600
Fax: 1-815-639-8000
www.danfossdrives.com

Danfoss Drives

8800 W. Bradley Rd.
Milwaukee, WI 53224 USA
Phone: 1-800-621-8806
1-414-355-8800
Fax: 1-414-355-6117
www.danfossdrives.com

