

■ Contents

| | |
|---|-----------|
| Introduction | 4 |
| Software version | 4 |
| Disposal Instruction | 4 |
| Safety regulations | 5 |
| Warning against unintended start | 5 |
| Introduction | 6 |
| Integration of frequency converter and motor | 7 |
| Key diagram for FCM 300 Series | 8 |
| Product range | 9 |
| Ordering | 9 |
| Ordering info for Frames and Flanges | 11 |
| Ordering info for inverter box position and drain hole position | 11 |
| Ordering form | 12 |
| | |
| Installation | 13 |
| FCM 305-375 for 3 phases, 380-480 V | 13 |
| General technical data | 13 |
| Tightening Torques | 17 |
| Maximum Cable Cross Section | 17 |
| Screw Sizes | 17 |
| Description of the motor | 18 |
| Handling the FC motor | 19 |
| Bearings | 19 |
| Output shafts | 19 |
| Dimensions | 20 |
| Installation of the FC motor | 23 |
| Alignment | 23 |
| Bolt torques | 24 |
| Maintenance | 24 |
| Forced ventilation (FV) units | 25 |
| Voltage range for forced ventilation (FV) unit | 25 |
| FCM 300 Thermal Protection | 25 |
| Control panel (175NO131) | 26 |
| LCP installation | 26 |
| LCP functions | 26 |
| Display | 26 |
| LEDs | 27 |
| Control keys | 27 |
| Control key functions | 27 |
| Display read-out state | 28 |
| Display mode | 28 |
| Display mode - selection of read-out state | 28 |
| Quick menu mode versus Menu mode | 29 |
| Quick Setup via Quick menu | 29 |
| Parameter selection | 29 |
| Menu mode | 30 |
| Parameter groups | 30 |

| | |
|---|-----------|
| Changing data | 30 |
| Changing a text value | 30 |
| Infinitely variable change of numeric data value | 30 |
| Menu structure | 32 |
| Service plug kit (175N2546) | 33 |
| Plug kit (175N2545) | 33 |
| Remote mounting kit (175N0160) | 33 |
| Potentiometer option (177N0011) | 34 |
| Local Operation Pad (LOP) (175N0128) IP65 | 34 |
| Programming | 36 |
| PC Software tools | 82 |
| Serial bus | 82 |
| Telegram communication | 82 |
| Telegram build-up | 82 |
| Databytes | 83 |
| Control word according to Fieldbus Profile Standard | 85 |
| All about FCM 300 | 91 |
| Galvanic isolation (PELV) | 91 |
| Earth leakage current | 91 |
| Extreme running conditions | 92 |
| Acoustic noise | 92 |
| Balance | 92 |
| Thermal Protection and Derating | 93 |
| Derating for ambient temperature | 93 |
| Derating for air pressure | 93 |
| Derating for running at low speed | 93 |
| Derating for high switching frequency | 93 |
| Vibration and shock | 94 |
| Air humidity | 94 |
| UL standard | 94 |
| Efficiency | 95 |
| Mains supply interference/harmonics | 95 |
| Power factor | 95 |
| What is CE labelling? | 95 |
| The machinery directive(98/37/EEC) | 95 |
| The low-voltage directive (73/23/EEC) | 96 |
| The EMC directive(89/336/EEC) | 96 |
| What is covered? | 96 |
| Danfoss FCM 300 Series motor and CE labelling | 96 |
| Compliance with EMC directive 89/336/EEC | 96 |
| EMC standards | 97 |
| Aggressive environments | 98 |
| List of warnings and alarms | 99 |
| What if the motor does not start? | 99 |
| Warnings | 100 |
| Warning word, extended Status word and Alarm word | 101 |
| List of parameters | 103 |

**FCM 300 Series
Design Guide
Software version: 2.9x**



This Design Guide can be used for all FCM 300 Series frequency converters with software version 2.9x. The software version number can be seen from parameter 624 Software version no.

■ **Disposal Instruction**



Equipment containing electrical components may not be disposed of together with domestic waste. It must be separately collected with Electrical and Electronic waste according to local and currently valid legislation.

When reading through this Design Guide, you will come across various symbols that require special attention.

The symbols used are the following:



This symbol indicates a general warning.



NB!

This symbol indicates something to be noted by the reader.



This symbol indicates a high-voltage warning.



All operations must be carried out by appropriately trained personnel.

Use all lifting facilities provided e.g. both lifting points if fitted or single lifting point if fitted*.

Vertical lifting - Prevent uncontrolled rotation.

Lift machine - Do not lift other equipment with motor lifting points only.

Before installation check for fan cover damage, shaft damage, foot/mounting damage, and loose fasteners. Check nameplate details.

Ensure level mounting surface, balanced mounting, not misaligned.

Gaskets, and/or sealants, and guards must be correctly fitted.

Correct belt tension.

Please observe derating rules, see "*Special conditions*".

*Note: maximum hand lift is 20 kg below shoulder, but above ground level. Max. gross weights:

- Frame size 80: 15 kg
- Frame size 90 & 100: 30 kg
- Frame size 112: 45 kg
- Frame size 132: 80 kg



The voltage on the FC motor is dangerous when the motor is connected to mains. Incorrect installation of the FC motor may lead to material damage or serious injury, or it may be fatal.

Consequently, the instructions in this manual as well as national and local rules and safety regulations must be complied with.

Touching the electrical parts may be fatal, even after the mains supply has been disconnected. Wait at least 4 minutes.

- Installation must be fused and isolated correctly.

- Covers and cable entries must be fitted.



By altitudes above 2 km, please contact Danfoss Drives regarding PELV.



NB!

It is the user's or certified electrician's responsibility to ensure correct earthing and protection in accordance with applicable national and local requirements and standards.

■ Safety regulations

1. The VLT DriveMotor (FC motor) must be disconnected from mains if repair work is to be carried out.
Check that the mains supply has been disconnected and that the necessary time has passed (4 minutes).
2. Correct protective earthing of the equipment must be established, the user must be protected against supply voltage, and the motor must be protected against overload in accordance with applicable national and local regulations.
Use of RCD's (ELCB relays) is described in chapter 10.
3. The earth leakage currents are higher than 3.5 mA. This means that the FC motor requires a fixed, permanent installation as well as reinforced protective earthing.

■ Warning against unintended start

1. The motor can be brought to a stop by means of digital commands, bus commands, or references, while the frequency converter is connected to mains.
If personal safety considerations make it necessary to ensure that no unintended start occurs, these stop functions are not sufficient.
2. While parameters are being changed, the motor may start.
3. A motor that has been stopped may start if faults occur in the electronics of the FC motor, or if a temporary overload or a fault in the mains supply ceases.

■ Introduction

Specific technical publications on the FCM 300 series:

Design Guide:

Gives all required information for design purposes, and gives a good insight into the product concept, product range, technical data, control, programming, etc.

Quick Setup:

Helps the users to quickly get their FCM 300 Series motor unit installed and running.

The Quick Setup is always delivered with the unit.

If you have any questions concerning FCM 300 Series, please call us. We have drive specialists all over the world ready to advise you on applications, programming, training and service.

Available literature

The chart below gives an overview of the literature available for the FCM 300 Series.

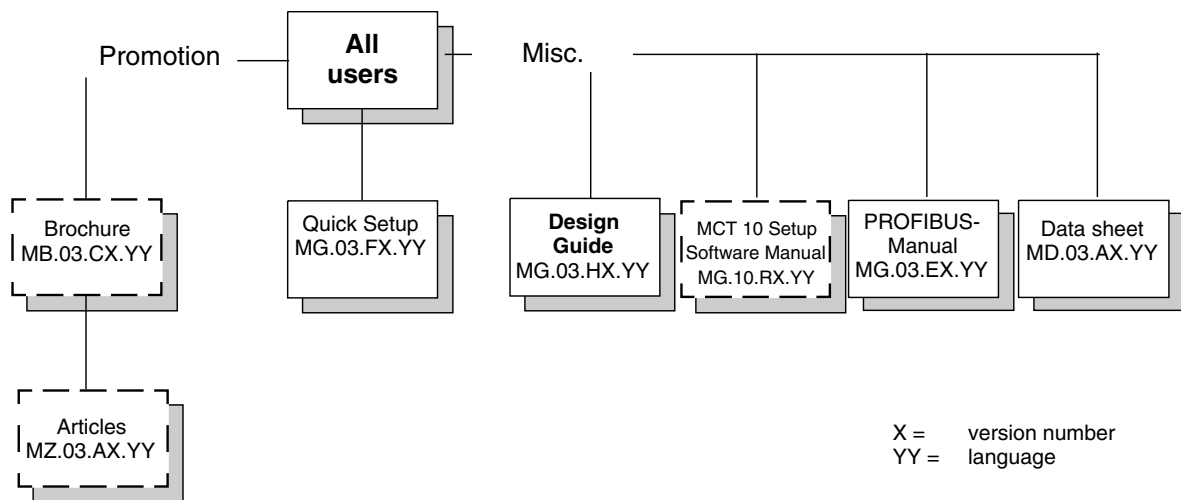

■ Integration of frequency converter and motor

The Danfoss VLT frequency converter integrated onto the asynchronous motor gives infinite speed control in one unit.

The VLT DriveMotor FCM 300 Series is a very compact alternative to the ordinary solution with VLT frequency converter and motor as separate units. The frequency converter is attached instead of the motor terminal box, and it is no higher than the standard terminal box, nor wider or longer than the motor (see chapter 6).

Installation is made extremely easy. Panel space is not a problem. There is no need for special details on wiring to meet the EMC directive, since motor cables are not necessary. The only connections are mains and control connections.

Factory-set adaption between frequency converter and motor gives precise and energy efficient control in addition to eliminating pre-setting on site.

The FC motor can be used in stand alone SYSTEMS with traditional control signals, such as start/stop signals, speed references and closed loop process control or in multiple drive SYSTEMS with control signals distributed by a field bus.

Combination of fieldbus and traditional control signals and closed loop PID control is possible.

Introduction

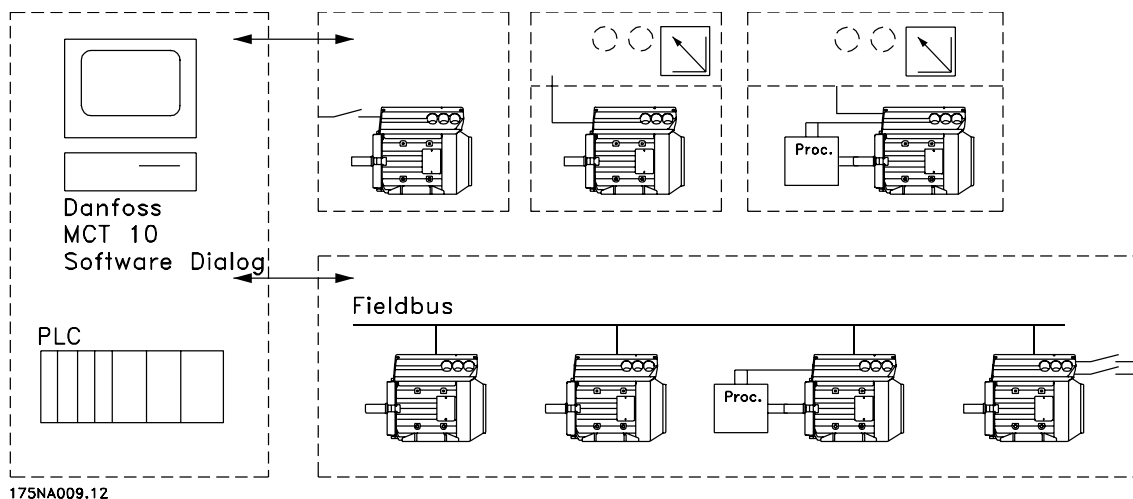

175NA009.12

Control structures

■ Key diagram for FCM 300 Series

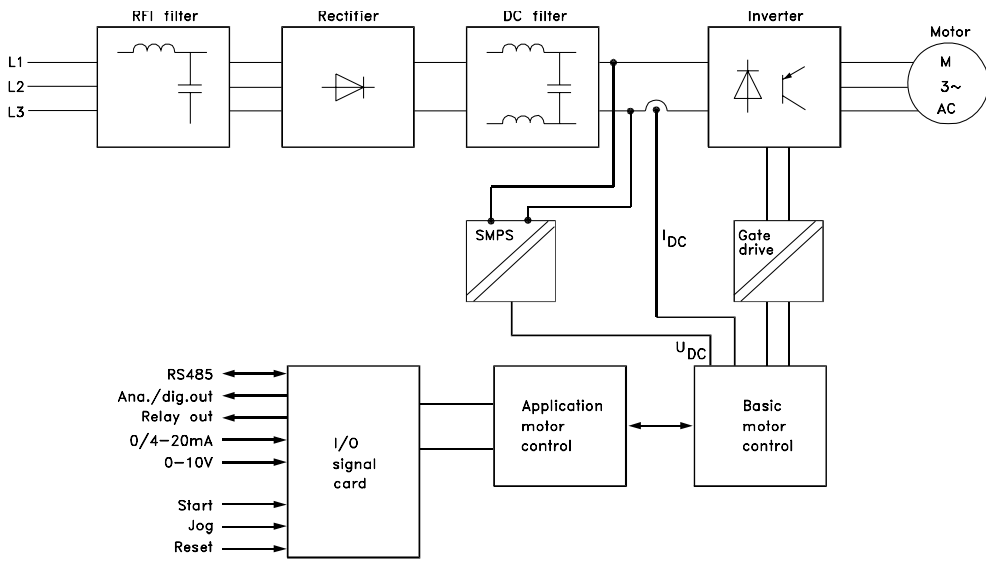

175NA010.12

■ Product range

VLT DriveMotor FCM 300 Series, 2/4 poled motors

| Type | Motor output | Mains supply |
|---------|--------------|-------------------|
| FCM 305 | 0.55 kW | 3 phase 380-480 V |
| FCM 307 | 0.75 kW | |
| FCM 311 | 1.1 kW | |
| FCM 315 | 1.5 kW | |
| FCM 322 | 2.2 kW | |
| FCM 330 | 3.0 kW | |
| FCM 340 | 4.0 kW | |
| FCM 355 | 5.5 kW | |
| FCM 375 | 7.5 kW | |

Each type in the product range is available in different versions:

Inverter versions

Power size:

(See power size table)

Application

- P: Process
- S: Sensorless (special pump OEM)

Mains voltage:

- T4: 380-480 V three phase supply

Enclosure

- C55: IP55
- C65: IP65
- C66: IP66

Hardware variant:

- ST: Standard

RFI filter

- R1: Compliance with class 1A
- R2: Compliance with class 1B

Display connector

- D0: No display plug able connector

Fieldbus

- F00: No fieldbus
- F10: Profibus DPV1 3 MB
- F12: Profibus DPV1 12 MB

Motor thermistor

- X: No motor thermistor

Number of poles

- 2: 2 pole motor
- 4: 4 pole motor

Motor data

- 00: ATB motor

Motor mounting option

- B03: Foot mounting
- B05: B5 flange
- B14: B14 face
- B34: Foot and B14 face
- B35: Foot and B5 flange

Motor flange size

(Regarding standard flange size and available flange sizes, see table)

- 000: Foot mounting only
- 075: 75 mm
- 085: 85 mm
- 100: 100 mm
- 115: 115 mm
- 130: 130 mm
- 165: 165 mm
- 215: 215 mm
- 265: 265 mm
- 300: 300 mm

Motor cooling method

- 1: Shaft mounted fan
- 2: Forced ventilation
- 3: Mechanical brake
- 4: Forced c ´ ventilation and mechanical brake

Motor drain hole position

(see drawing)

- D0: No drain hole
- D1: Opposite inverter box both ends (drive/ non drive)
- D2: 90 (deg) inverter box right
- D3: 90 (deg) inverter box left

■ Ordering

Take a copy of the ordering form, see section *Ordering form*. Fill in and post or fax your order to the nearest branch office of the Danfoss sales organisation. On the basis of your order, the FCM 300 Series motor is given a type code.

The ordering form for the basic unit must always be completed. When the type code is written, always state the characters of the basic string (1-34). Together with

the order confirmation the customer receives an 8-figure code number to be used when reordering.

Danfoss PC software for serial communication, MCT 10

All FCM 300 Series units have an RS 485 port as standard, which enables them to communicate e.g. with a PC. A programme entitled MCT 10 is available for this purpose (see section *PC Software tools*).

Ordering numbers, MCT 10

Please order your CD containing MCT 10 Set-up Software using code number 130B1000.

PC Software - VLT Software Dialog

For single or few unit installations a basic software package, VLT Software Dialog, is available. Please order using code number 175Z0967.

Accessories for the FC motor

A Local Operation Pad (LOP) for local set point and start/stop is available for the FC motor. The LOP is IP 66 enclosed. A Local Control Panel (LCP 2) which makes up a complete interface for operation, programming and monitoring of the FC motor is also available.

Ordering numbers, accessories

| | |
|---------------------------------|----------|
| Local Operation Pad (LOP) | 175N0128 |
| Local Control Panel (LCP 2) | 175N0131 |
| Remote mounting kit (LCP 2) | 175N0160 |
| Plug kit (LCP 2) | 175N2545 |
| Cable for plug kit (LCP 2) | 175N0162 |
| Cable (direct mounting) (LCP 2) | 175N0165 |
| Service plug kit (LCP 2) | 175N2546 |
| Potentiometer option | 177N0011 |

(Available from February 2005)

■ Ordering info for Frames and Flanges

Frame sizes and the corresponding flange sizes for different mounting versions

| Type | Motor frame size | Mounting version | Flange size, standard (S) [mm] | Flange size, alternatives* [mm] |
|---------|------------------|------------------|--------------------------------|---------------------------------|
| FCM 305 | 80 | B5/B35 | 165 | 100/115/130/215 |
| | | B14/B34 | 100 | 85/115/130 |
| FCM 307 | 80 | B5/B35 | 165 | 100/115/130/215 |
| | | B14/B34 | 100 | 85/115/130 |
| FCM 311 | 90 | B5/B35 | 165 | 130/215 |
| | | B14/B34 | 115 | 100/130 |
| FCM 315 | 90 | B5/B35 | 165 | 130/215 |
| | | B14/B34 | 115 | 100/130 |
| FCM 322 | 100 | B5/B35 | 215 | 165/265 |
| | | B14/B34 | 130 | 115/165 |
| FCM 330 | 100 | B5/B35 | 215 | 165/265 |
| | | B14/B34 | 130 | 115/165 |
| FCM 340 | 112 | B5/B35 | 215 | 165/265 |
| | | B14/B34 | 130 | 165 |
| FCM 355 | 132 | B5/B35 | 265 | 215/300 |
| | | B14/B34 | 165 | 130 |
| FCM 375 | 132 | B5/B35 | 265 | 215/300 |
| | | B14/B34 | 165 | 130 |

Flange size according to IEC ref. FFxxx (Dimension M), see section *Dimensions*

S: Available as standard shaft

* No changes regarding shaft dimensions

■ Ordering info for inverter box position and drain hole position

Inverter box position, always top mounted.

All drain holes are mounted with screw and washer, IP 66 if not opened.

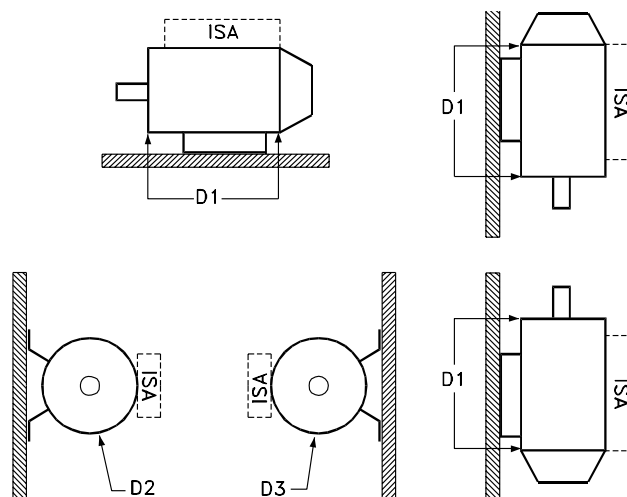

D1: Drain holes opposite inverter side, both drive end and non drive end.

D2/D3: Drain holes 90° to inverter, both drive end and non drive end.

175NA125.10

Ordering form

175MA121.12

FCM 3 - - T4 - C - ST - R - D - F - X - 00 - B - - - D

Power Sizes

305
307
311
315
322
330
340
355
375

Application range

P
S

Mains voltage

T4

Enclosure

C55
C65
C66

Hardware variant

ST

RFI-filter

R1
R2

Display accessory

D0

Fieldbus

F00
F10
F12

Thermistor

X

Number of poles

2
4

Motor data

00

Motor mounting option

B03
B05
B14
B34
B35

Motor flange size

000
075
085
100
115
130
165
215
265
300

Motor cooling method

1
2
3
4

Motor drain hole position

D0
D1
D2
D3

No. unit of this type

Required delivery date

Ordered by:

Date: _____

Please take a copy of the ordering form.
Fill it in and send or fax your order
to the nearest Danfoss rep. office.

■ FCM 305-375 for 3 phases, 380-480 V

| FCM | 305 | 307 | 311 | 315 | 322 | 330 | 340 | 355 | 375 |
|-------------------------------------|-----------|-----------|-----------|-----------|-----------|-----------|-----------|-----------------------|-----------------------|
| Motor output | | | | | | | | | |
| [HP] | 0.75 | 1.0 | 1.5 | 2.0 | 3.0 | 4.0 | 5.0 | 7.5 | 10.0 |
| [kW] | 0.55 | 0.75 | 1.1 | 1.5 | 2.2 | 3.0 | 4.0 | 5.5 | 7.5 |
| Motor torque | | | | | | | | | |
| 2 pole [Nm] ¹⁾ | 1.8 | 2.4 | 3.5 | 4.8 | 7.0 | 9.5 | 12.6 | 17.5 | 24.0 |
| 4 pole [Nm] ²⁾ | 3.5 | 4.8 | 7.0 | 9.6 | 14.0 | 19.1 | 25.4 | 35.0 | 48.0 |
| Frame size [mm] | 80 | 80 | 90 | 90 | 100 | 100 | 112 | 132 | 132 |
| Weight [kg] | 11 | 13 | 17 | 20 | 26 | 28 | 37 | 56 | 61 |
| Input current [A] | | | | | | | | | |
| 380 V | | | | | | | | | |
| 2 p | 1.5 | 1.8 | 2.3 | 3.4 | 4.5 | 5.0 | 8.0 | 12.0 | 15.0 |
| 4 p | 1.4 | 1.7 | 2.5 | 3.3 | 4.7 | 6.4 | 8.0 | 11.0 | 15.5 |
| 480 V | | | | | | | | | |
| 2 p | 1.2 | 1.4 | 1.8 | 2.7 | 3.6 | 4.0 | 6.3 | 9.5 | 11.9 |
| 4 p | 1.1 | 1.3 | 2.0 | 2.6 | 3.7 | 5.1 | 6.3 | 8.7 | 12.3 |
| Efficiency at nom. speed (4 pole) % | 66 | 71 | 74 | 80 | 80 | 81 | 80 | 84 | 84 |
| Efficiency at nom. speed (2 pole) % | 61 | 64 | 76 | 75 | 76 | 85 | 82 | 83 | 91 |
| Power terminals [AWG] | 10 | 10 | 10 | 10 | 10 | 10 | 10 | 6 | 6 |
| [mm ²] | 4 | 4 | 4 | 4 | 4 | 4 | 4 | 10 | 10 |
| Gland sizes | 3xM20x1.5 | 3xM20x1.5 | 3xM20x1.5 | 3xM20x1.5 | 3xM20x1.5 | 3xM20x1.5 | 3xM20x1.5 | 1xM25x1.5 / 2xM20x1.5 | 1xM25x1.5 / 2xM20x1.5 |
| Max. prefuse UL ³⁾ [A] | 10 | 10 | 10 | 10 | 10 | 15 | 15 | 25 | 25 |
| IEC ³⁾ [A] | 25 | 25 | 25 | 25 | 25 | 25 | 25 | 25 | 25 |

¹⁾ At 400 V 3000 r/min

²⁾ At 400 V 1500 r/min

³⁾ Type gG prefuses must be used. If you want to maintain UL/cUL you must use prefuses of the type Bussmann KTS-R 500 V or Ferraz Shawmut, ATMR Class C (max. 30A). The fuses must be placed for protection in a circuit that is capable of supplying a maximum of 100,000 amps RMS (symmetrical), 500 V maximum.

■ General technical data

Mains supply, TT, TN and IT* (L1, L2, L3):

| | |
|--|------------------------------------|
| - Supply voltage 380-480 V units | 3 x 380/400/415/440/460/480 V ±10% |
| - Supply frequency | 50/60 Hz |
| - Max. imbalance of supply voltage | ±2% of rated supply voltage |
| - Power factor / cos | max. 0.9/1.0 at rated load |
| - No. of switching operations on supply input L1, L2, L3 | approx. 1 time/2 min |

*) Not valid for RFI class 1B units

Torque characteristics:

| | |
|-----------------------------------|-----------------|
| - Starting torque/overload torque | 160 % for 1 min |
| - Continuous torque | see above |

Control card, digital/pulse inputs:

| | |
|---|---------------------------------|
| - Number of programmable digital inputs | 4 |
| - Terminal nos. | X101-2, -3, -4, -5 |
| - Voltage level | 0-24 V DC (PNP positive logics) |
| - Voltage level, logic 0 | < 5 V DC |
| - Voltage level, logic 1 | > 10 V DC |
| - Maximum voltage on input | 28 V DC |
| - Input resistance, R _i | approx. 2 kΩ |
| - Scanning time | 20 msec |

VLT® FCM Series

Control card, pulse input:

| | |
|---|--------------------------------|
| - No. of programmable pulse inputs | 1 |
| - Terminal nos. | X101-3 |
| - Max. frequency on terminal 3, open collector/push pull 24 V | 8 kHz/70 kHz |
| - Resolution | 10 bit |
| - Accuracy (0.1-1 kHz), terminal 3 | Max. error: 0.5% of full scale |
| - Accuracy (1-12 kHz), terminal 3 | Max. error: 0.1% of full scale |

Control card, analogue inputs:

| | |
|---|-----------------------------|
| - No. of programmable analogue voltage inputs | 1 |
| - Terminal nos. | X101-2 |
| - Voltage level | 0 - 10 V DC (scalable) |
| - Input resistance, R_i | approx. 10 k Ω |
| - No. of programmable analogue current inputs | 1 |
| - Terminal no. | X101-1 |
| - Current range | 0 - 20 mA (scalable) |
| - Input resistance, R_i | approx. 300 Ω |
| - Resolution | 9 bit |
| - Accuracy on input | Max. error 1% of full scale |
| - Scanning time | 20 msec. |

Control card, digital/pulse and analogue outputs:

| | |
|---|--------------------------------|
| - No. of programmable digital and analogue outputs | 1 |
| - Terminal nos. | X101-9 |
| - Voltage level at digital output/load | 0 - 24 V DC/25 mA |
| - Current at analogue output | 0 - 20 mA |
| - Maximum load to frame (terminal 8) at analogue output | R_{LOAD} 500 Ω |
| - Accuracy of analogue output | Max. error: 1.5% of full scale |
| - Resolution on analogue output. | 8 bit |

Relay output:

| | |
|---|------------------------------------|
| - No. of programmable relay outputs | 1 |
| - Terminal number (resistive and inductive load) | 1-3 (break), 1-2 (make) |
| - Max. terminal load (AC1) on 1-3, 1-2 | 250 V AC, 2A, 500 VA |
| - Max. terminal load (DC1) (IEC 947) on 1-3, 1-2 | 25 V DC, 3A / 50 V DC, 1.5 A, 75 W |
| - Min. terminal load (AC/DC) on 1-3, 1-2 control card | 24 V DC, 10 mA/ 24 V AC, 100 mA |

Rated values for up to 300,000 operations (at inductive loads the number of operations is reduced by 50%)

Control card, RS 485 serial communication:

| | |
|-----------------|------------|
| - Terminal nos. | X100-1, -2 |
|-----------------|------------|

Control characteristics (frequency converter):

| | |
|---|---|
| | 0 - 132 Hz |
| - Frequency range | <i>Please see special conditions for frequency range for IP 66 motors at the end of this section.</i> |
| - Resolution on output frequency | 0.1 % |
| - System response time | Max. 40 msec. |
| - Speed accuracy (open loop, CT mode, 4 P motor driven in speed range 150-1500 rPm) | +/- 15 rpm |

Externals:

| | |
|--------------------------|---|
| | IP 55 (IP56, IP66) |
| - Enclosure | <i>Please see special conditions for frequency range for IP 66 motors at the end of this section.</i> |
| - Vibration test | (IEC 68 see page 93) 1 g |
| - Max. relative humidity | 95 % (IEC 68-2-3) for storage/transport/operation |
| - Ambient temperature | Max. 40°C (24-hour average max. 35°C) |

see Derating for high ambient temperature

| | |
|---|----------------|
| - Min. ambient temperature in full operation | 0°C |
| - Min. ambient temperature at reduced performance | -10°C |
| - Temperature during storage/transport | -25 - +65/70°C |
| - Max. altitude above sea level | 1000 m |

see Derating for air pressure

| | |
|-----------------------------------|---|
| - EMC standards applied, Emission | EN 61000-6-3/EN 6100-6-4, EN 61800-3, EN 55011, EN 55014 EN 61000-6-2, EN 61000-4-2, EN 61000-4-3, EN 61000-4-4, EN 61000-4-5, |
| - EMC standards applied, Immunity | EN 61000-4-6, ENV 50204 |
| - Safety standards applied, | EN 60146, EN 50178, EN 60204, UL508 |



NB!

Please note that the normal IP 66 solution is only intended for speed up to maximum

3000 rpm. If higher speed is needed, please give notification when ordering.

Installation

Protection:

- Thermal overload protection of motor and electronics.
- Monitoring of the intermediate circuit voltage ensures that the inverter cuts out if the intermediate circuit voltage gets too high or too low.
- If a mains phase is missing, the inverter will cut out when a load is placed on the motor.

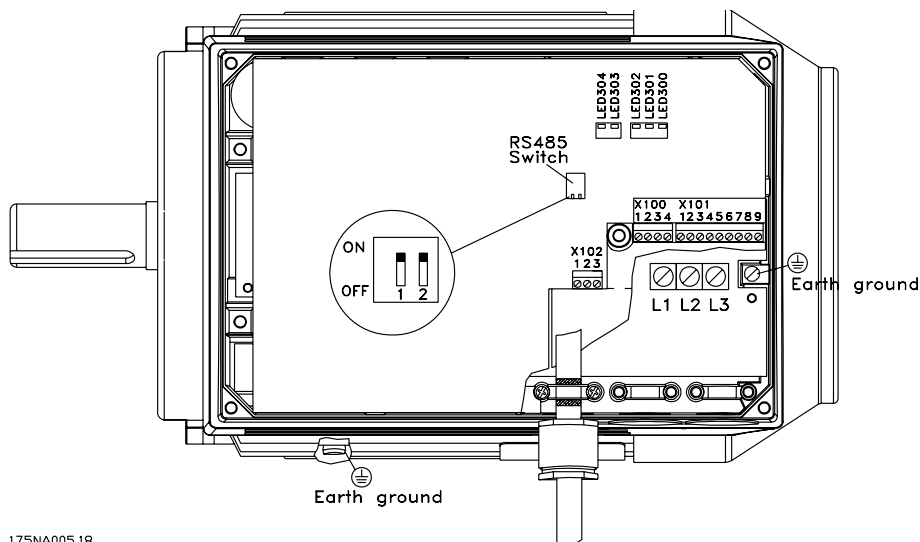

175NA005.18

Terminal arrangement (for installation see quick setup, MG.03.AX.62)

X101: Terminal block for analogue/digital control signals

| Terminal No. | Function | Example |
|--------------|---|-------------------|
| 1 | Analogue input (0-20 mA) | Feedback signal |
| 2 | Analogue (0-10 V)/digital input 2 | Speed reference |
| 3 | Digital input (or pulse) 3 | Reset |
| 4 | Digital input (or precise stop) 4 | Start |
| 5 | Digital input (other) 5 | Jog (fixed speed) |
| 6 | 24 V DC supply for digital inputs (max. 150 mA) | |
| 7 | 10 V DC supply for potentiometer (max. 15 mA) | |
| 8 | 0 V for terminals 1-7 and 9 | |
| 9 | Analogue (0-20 mA)/digital output | Fault indication |

Connection diagram - factory setting

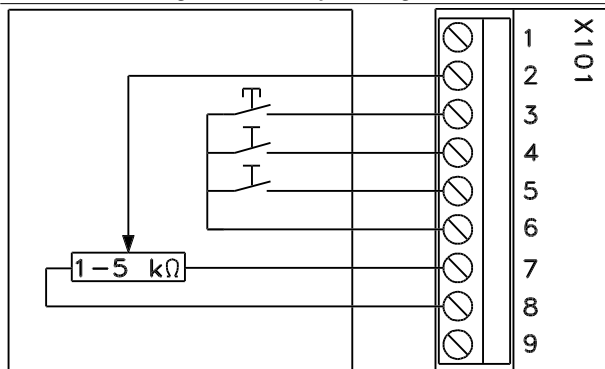

DANFOSS
175NA008.10

- Reset to be closed short time for resetting fault trips
- Start to be closed for changing to run mode
- Jog will run at fixed speed while closed (10 Hz)
- Speed reference (0-10 V) determines speed while in run mode

X102: Terminal block for relay output

| Terminal No. | Function |
|--------------|-------------------------|
| 1-2 | Make (normally open) |
| 1-3 | Brake (normally closed) |

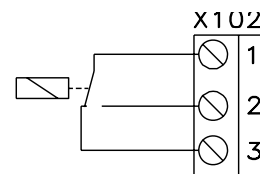

175NA122.10

See parameter 323 (relay output) for programming of relay output.

X100: Terminal block for data communication

| Terminal No. | Function |
|--------------|----------------------------|
| 1 | P RS 485 for connection to |
| 2 | N RS 485 bus or PC |
| 3 | 5 V DC Supply for RS |
| 4 | 0 V DC 485 bus |

- LED 300-304
- LED 300 (red): Fault trip
- LED 301 (yellow): Warning
- LED 302 (green): Power on
- LED 303-304: Communication

For PROFIBUS versions please refer to the manual MG.90.AX.YY.

■ Tightening Torques

| | |
|--|-----------------------------|
| Cover (lid) screws: | 25.6 - 31lb-in (3 - 3.5 Nm) |
| Plastic cable entrance plugs: | 19.5 lb-in (2.2 Nm) |
| L1, L2, L3 (AC Line) screws (FCM 305-340): | 5 - 7 lb-in (0.5 - 0.6 Nm) |
| L1, L2, L3 (AC Line) screws (FCM 355-375): | 15 lb-in (1.2 - 1.5 Nm) |
| Earth Ground: | 30.1 lb-in (3.4 Nm) |

Terminal screws require a max 2.5 mm flat-blade screwdriver.

AC Line screws require a 8mm flat-blade screwdriver.

Lid screws , earth ground and cable clamp screws all require T-20 Torx or flat-blade screwdriver (max. tightening speed 300 RPM).

■ Maximum Cable Cross Section

Note:

Use °60 C copper wire or better

| | AWG | mm ² |
|---------------------------------------|-----|-----------------|
| Max size AC Line cable (FCM 305-340): | 10 | 4.0 |
| Max size AC Line cable (FCM 355-375): | 6 | 10 |
| Max size control cable: | 16 | 1.5 |
| Max size serial communication cable: | 16 | 1.5 |
| Earth Ground: | 6 | 10 |

■ Screw Sizes

| | |
|--|----|
| Cover (lid) screws: | M5 |
| Earth Ground and Cable Clamp screws (FCM 305-340): | M4 |
| Earth Ground and Cable Clamp screws (FCM 355-375): | M5 |

■ Description of the motor

The FC motor consists of the following parts:

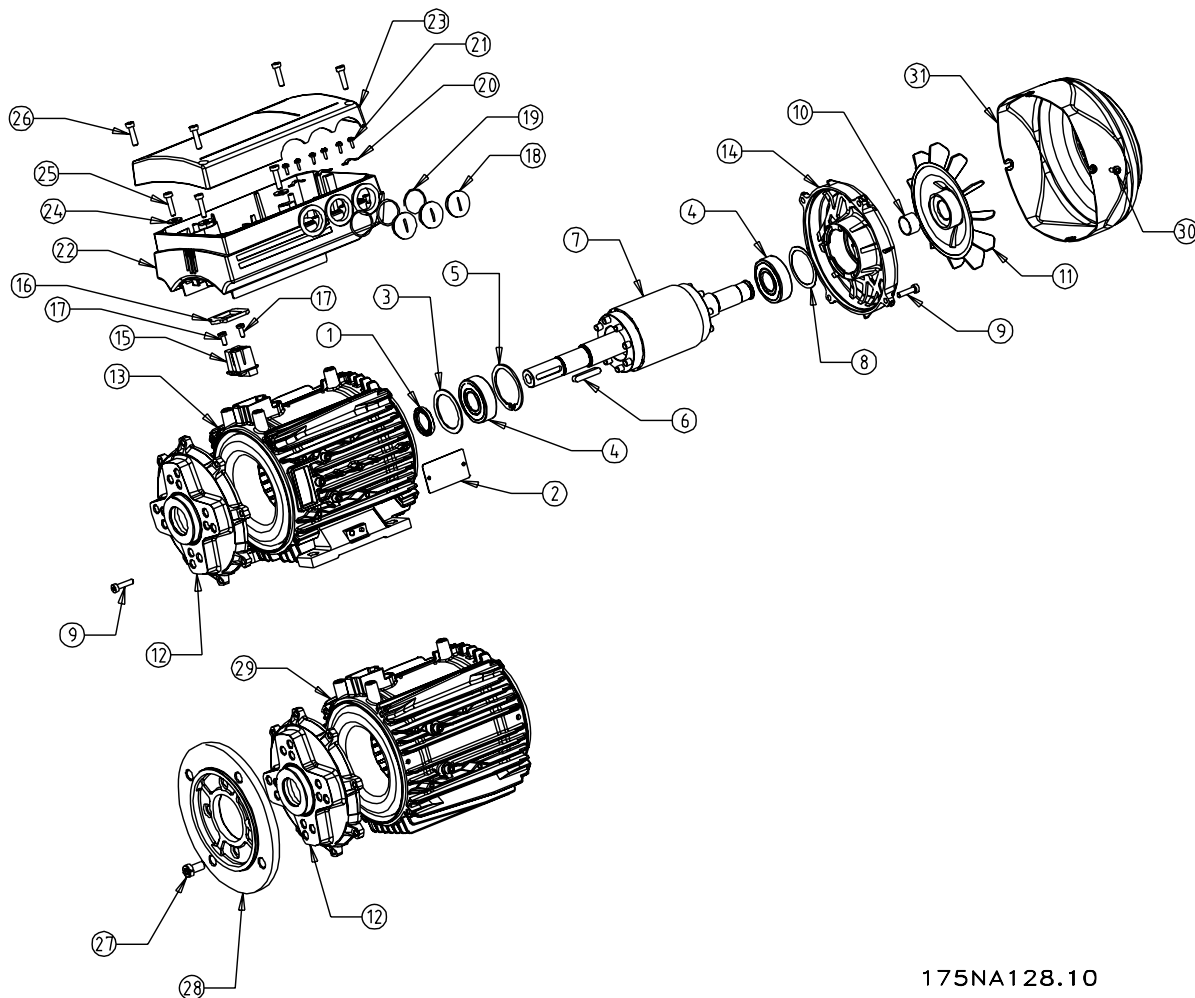

175NA128.10

| Item | Description |
|------|-------------------------------|
| 1 | Gasket |
| 2 | Name plate |
| 3 | Shim ring |
| 4 | Ball bearing |
| 5 | Circlip for drive-end bearing |
| 6 | Key |
| 7 | Rotor |
| 8 | Shim ring for bearing |
| 9 | Tension screws |
| 10 | Tolerance ring for air blower |
| 11 | Air blower |
| 12 | Endshield drive end |
| 13 | Stator |
| 14 | Endshield non drive end |
| 15 | Connector block |
| 16 | Gasket |
| 17 | Screws for connector block |
| 18 | Metric blind plugs |

| Item | Description |
|------|-------------------------------------|
| 19 | Gaskets for cable glands |
| 20 | Cable Clamps |
| 21 | Screws for cable clamps |
| 22 | Frequency inverter |
| 23 | Lid for frequency inverter |
| 24 | Gasket |
| 25 | Torx-screws for inverter monting |
| 26 | Screws for lid |
| 27 | Mounting screws for flange ring |
| 28 | Flange ring |
| 29 | Stator |
| 30 | Mounting screws for air blower hood |
| 31 | Air blower hood |

■ Handling the FC motor

Handling and lifting of VLT DriveMotors (FC motors) must only be undertaken by qualified personnel. Full product documentation and operating instructions must be available together with tools and equipment necessary for safe working practice. Eyebolts and/or lifting trunnions supplied with the FC motor are designed to support only the weight of the FC motor, not the weight of the FC motor and any auxiliary equipment attached to it. Be absolutely sure that cranes, jacks, slings and lifting beams are capable of carrying the weight of equipment to be lifted. Where an eyebolt is provided with the motor, this should be screwed

down until its shoulder is firmly against the face of the stator frame to be lifted.

| FCM type | approx. weight (kg.) |
|----------|----------------------|
| FCM 305 | 11 |
| FCM 307 | 13 |
| FCM 307 | 17 |
| FCM 315 | 20 |
| FCM 322 | 26 |
| FCM 330 | 28 |
| FCM 340 | 37 |
| FCM 355 | 56 |
| FCM 375 | 61 |

■ Bearings

The standard solution is fixed bearing in the drive side of the motor (shaft output side).

To avoid static indentation, the storage area should be vibration free. Where exposure to some vibration is unavoidable, the shaft should be locked. Bearings may be fitted with a shaft locking device which should be

kept in place during storage. Shafts should be rotated by hand, one quarter of a revolution, at weekly intervals. Bearings are despatched from the works fully charged with lithium based grease.

Lubrication

| Frame size | Lubrication type | Temperatur range |
|------------|------------------|------------------|
| 80-132 | Esso unirex N3 | -10 to + 1400°C |

Bearing life

Maximum hours bearing life (L_{na}) expected at 80° C bearing temp. x 10³ hours.

| FCM | 3000 min ⁻¹ | | 1500 min ⁻¹ | |
|---------|------------------------|-------|------------------------|-------|
| | Horiz. | Vert. | Horiz. | Vert. |
| 305-315 | 22 | 22 | 30 | 30 |
| 322-340 | 26 | 26 | 30 | 30 |
| 355-375 | 26 | 26 | 30 | 30 |

L_{na} bearing life is the adjusted, L₁₀ life rating, taking account of: -Reliability -Material improvement -Lubrication conditions.

Standard Bearing references and oil seals

| FCM | Mounting | Poles (2/4) | Bearings | | Oil seals - Bore x O/D x width in mm |
|---------|----------|-------------|------------|---------------|--------------------------------------|
| | | | Drive end | Non-drive end | |
| 305-307 | All | All | 6204 2Z-C3 | 6204 2RS-C3 | 20 x 30 x 7 |
| 311-315 | All | All | 6205 2Z-C3 | 6205 2RS-C3 | 25 x 35 x 7 |
| 322-330 | All | All | 6206 2Z-C3 | 6206 2RS-C3 | 30 x 42 x 7 |
| 340 | All | All | 6206 2Z-C3 | 6206 2RS-C3 | 30 x 42 x 7 |
| 355-375 | All | All | 6208 2Z-C3 | 6208 2RS-C3 | 40 x 52 x 7 |

■ Output shafts

Balance

All motors are dynamically balanced, to ISO 8821 with key convention to IEC 60034-14.

VLT® FCM Series

Inertia J [kgm²]

| FCM | 2 pole | 4 pole |
|-----|---------|--------|
| 305 | 0.00082 | 0.0019 |
| 307 | 0.00082 | 0.0027 |
| 311 | 0.00090 | 0.0022 |
| 315 | 0.0011 | 0.0030 |
| 322 | 0.0024 | 0.0042 |
| 330 | 0.0028 | 0.0050 |
| 340 | 0.0053 | 0.0091 |
| 355 | 0.0072 | 0.0143 |
| 375 | 0.0097 | 0.0190 |

■ Dimensions

Foot mounting - B3

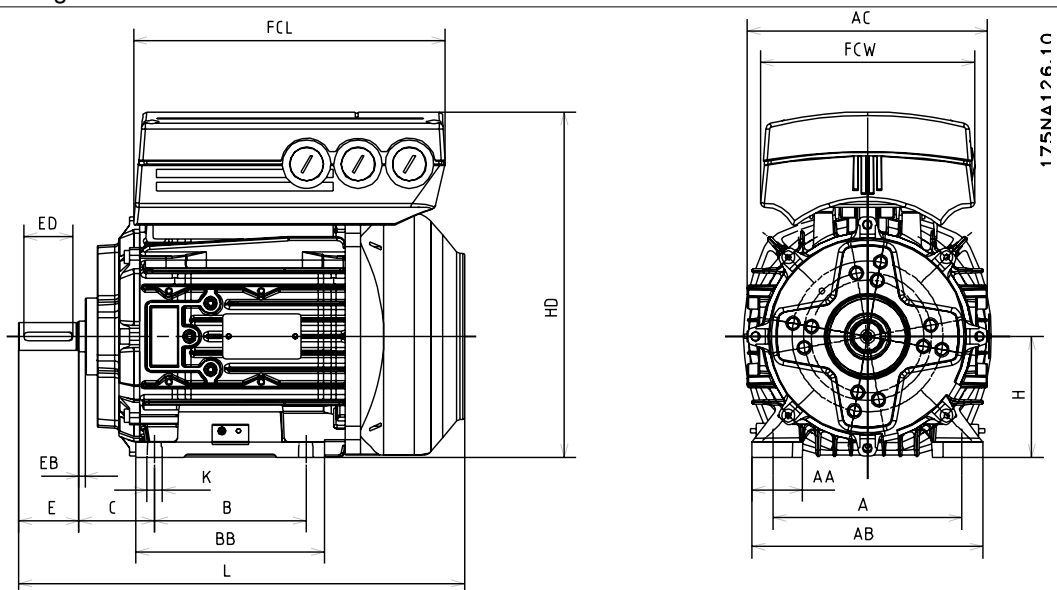

General

| FCM | 305 | 307 | 311 | 315 | 322 | 330 | 340 | 355 | 375 |
|------------|-------|-------|-----|-----|-----|-----|-----|-----|-----|
| Frame size | 80 | 80 | 90 | 90 | 100 | 100 | 112 | 132 | 132 |
| A [mm] | 125 | 125 | 140 | 140 | 160 | 160 | 190 | 216 | 216 |
| B [mm] | 100 | 100 | 125 | 125 | 140 | 140 | 140 | 178 | 178 |
| C [mm] | 50 | 50 | 56 | 56 | 63 | 63 | 70 | 89 | 89 |
| H [mm] | 80 | 80 | 90 | 90 | 100 | 100 | 112 | 132 | 132 |
| K [mm] | 9 | 9 | 9 | 9 | 12 | 12 | 12 | 12 | 12 |
| EB [mm] | 4 | 4 | 5 | 5 | 5 | 5 | 5 | 5 | 5 |
| AA [mm] | 33.5 | 33.5 | 35 | 35 | 38 | 38 | 44 | 55 | 55 |
| AB [mm] | 153 | 153 | 170 | 170 | 195 | 195 | 225 | 256 | 256 |
| BB [mm] | 125 | 125 | 155 | 155 | 176 | 176 | 176 | 218 | 218 |
| L [mm] | 295 | 295 | 319 | 319 | 336 | 336 | 380 | 485 | 485 |
| AC [mm] | 159 | 159 | 176 | 176 | 196 | 196 | 220 | 246 | 246 |
| HD [mm] | 228.5 | 228.5 | 241 | 241 | 267 | 267 | 296 | 344 | 344 |
| FCL [mm] | 206 | 206 | 230 | 230 | 256 | 256 | 286 | 340 | 340 |
| FCW [mm] | 141 | 141 | 158 | 158 | 176 | 176 | 197 | 235 | 235 |

VLT® FCM Series

Flange mounting - B5, B35 (B3+B5)

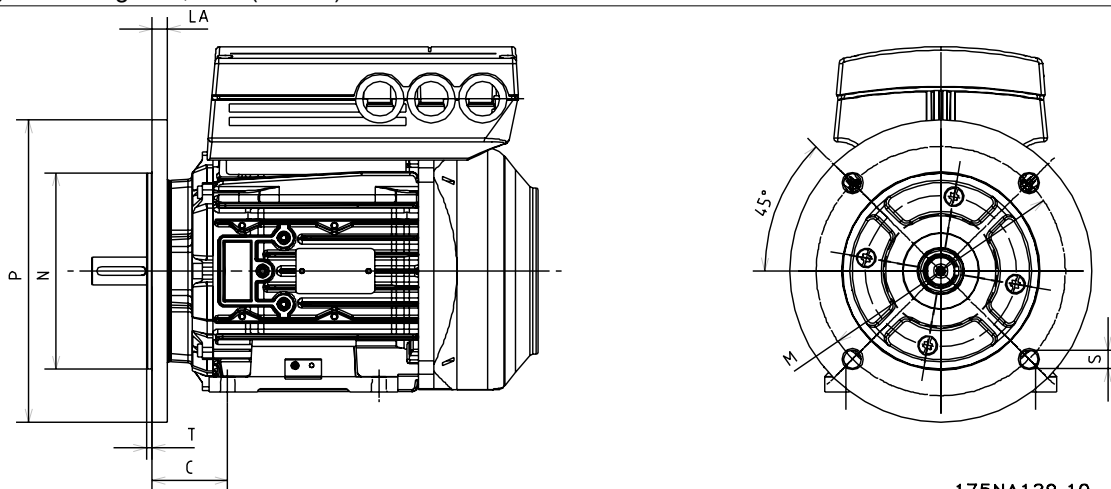

175NA129.10

B5

| FCM | 305 | 307 | 311 | 315 | 322 | 330 | 340 | 355 | 375 |
|------------|-------|-------|-------|-------|-------|-------|-------|-------|-------|
| Frame size | 80 | 80 | 90 | 90 | 100 | 100 | 112 | 132 | 132 |
| IEC Ref. | FF165 | FF165 | FF165 | FF165 | FF215 | FF215 | FF215 | FF265 | FF265 |
| DIN Ref. | A200 | A200 | A200 | A200 | A250 | A250 | A250 | A300 | A300 |
| M [mm] | 165 | 165 | 165 | 165 | 215 | 215 | 215 | 265 | 265 |
| N [mm] | 130 | 130 | 130 | 130 | 180 | 180 | 180 | 250 | 230 |
| P [mm] | 200 | 200 | 200 | 200 | 250 | 250 | 250 | 300 | 300 |
| S [mm] | 12 | 12 | 11.5 | 11.5 | 14 | 14 | 14 | 14 | 14 |
| T [mm] | 3.5 | 3.5 | 3.5 | 3.5 | 4 | 4 | 4 | 4 | 4 |
| LA [mm] | 10 | 10 | 10 | 10 | 11 | 11 | 11 | 12 | 12 |

Face mounting - B14, B34 (B3+B14)

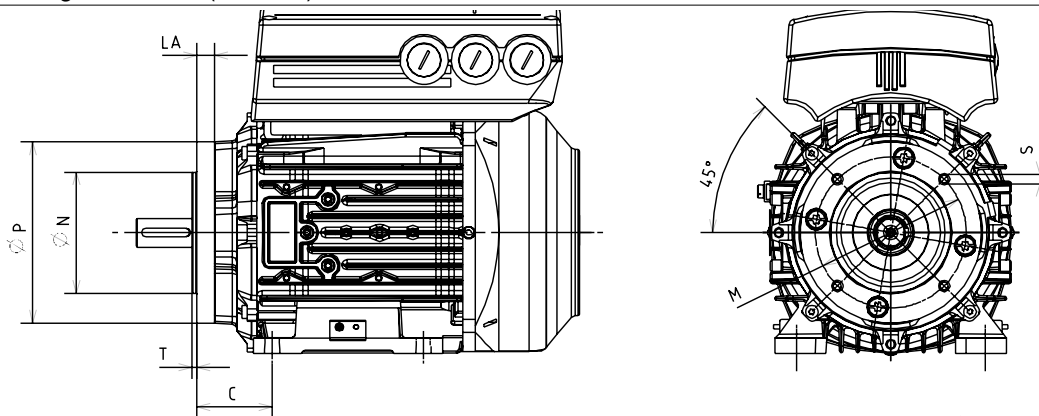

175NA127.11

B14

| FCM | 305 | 307 | 311 | 315 | 322 | 330 | 340 | 355 | 375 |
|------------|-------|-------|-------|-------|-------|-------|-------|-------|-------|
| Frame size | 80 | 80 | 90 | 90 | 100 | 100 | 112 | 132 | 132 |
| IEC Ref. | FT100 | FT100 | FT115 | FT115 | FT130 | FT130 | FT130 | FT165 | FT165 |
| DIN Ref. | C120 | C120 | C140 | C140 | C160 | C160 | C160 | C200 | C200 |
| M [mm] | 100 | 100 | 115 | 115 | 130 | 130 | 130 | 165 | 165 |
| N [mm] | 80 | 80 | 95 | 95 | 110 | 110 | 110 | 130 | 130 |
| P [mm] | 120 | 120 | 140 | 140 | 160 | 160 | 160 | 200 | 200 |
| S [mm] | M6 | M6 | M8 | M8 | M8 | M8 | M8 | M10 | M10 |
| T [mm] | 3 | 3 | 3 | 3 | 3.5 | 3.5 | 3.5 | 3.5 | 3.5 |
| LA [mm] | 12 | 12 | 10 | 10 | 10 | 10 | 10 | 12 | 12 |

Shaft Drive End

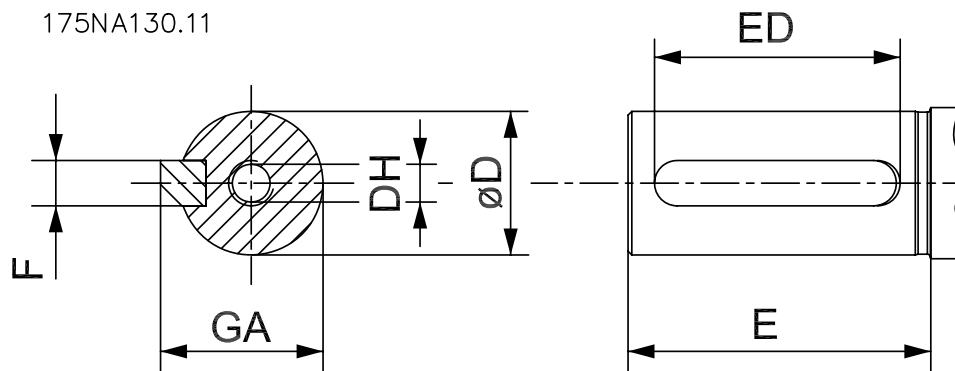

Shaft tapped
DH x deep to
DIN 332 Form DR
Closed profile keyway

| | | | | | | | | | |
|------------|-------|-------|-------|-------|--------|--------|--------|--------|--------|
| FCM | 305 | 307 | 311 | 315 | 322 | 330 | 340 | 355 | 375 |
| Frame size | 80 | 80 | 90 | 90 | 100 | 100 | 112 | 132 | 132 |
| ØD [mm] | 19 | 19 | 24 | 24 | 28 | 28 | 28 | 38 | 38 |
| E [mm] | 40 | 40 | 50 | 50 | 60 | 60 | 60 | 80 | 80 |
| ED [mm] | 32 | 32 | 40 | 40 | 50 | 50 | 50 | 70 | 70 |
| DH [mm] | M6x16 | M6x16 | M8x19 | M8x19 | M10x22 | M10x22 | M10x22 | M12x28 | M12x28 |
| F [mm] | 6 | 6 | 8 | 8 | 8 | 8 | 8 | 10 | 10 |
| GA [mm] | 21.5 | 21.5 | 27 | 27 | 31 | 31 | 31 | 41 | 41 |

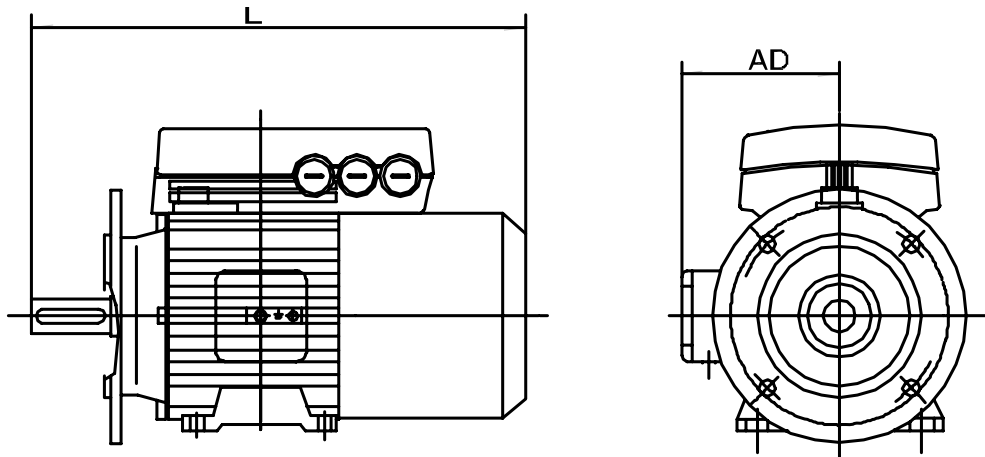

175NA136.10

| | | | | | | | | | |
|--|-------|-------|-------|-------|-----|-----|-----|-----|-----|
| FCM | 305 | 307 | 311 | 315 | 322 | 330 | 340 | 355 | 375 |
| Frame size | 80 | 80 | 90 | 90 | 100 | 100 | 112 | 132 | 132 |
| AD [mm] | 132 | 132 | 160 | 160 | 170 | 170 | 182 | 195 | 195 |
| Mechanical brake | | | | | | | | | |
| L [mm] | 370,5 | 370,5 | 383 | 383 | 437 | 437 | 454 | 584 | 584 |
| Forced ventilation | | | | | | | | | |
| L [mm] | 386 | 386 | 427,5 | 427,5 | 440 | 440 | 482 | 616 | 616 |
| Mechanical brake and forced ventilation | | | | | | | | | |
| L [mm] | 456 | 456 | 468 | 468 | 537 | 537 | 550 | 707 | 707 |

■ Installation of the FC motor

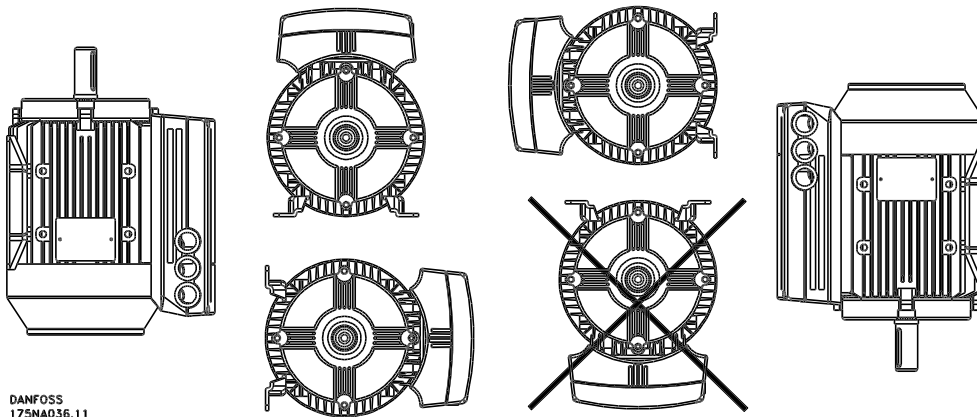

DANFOSS
175NA036.11

FC motors must be installed with adequate access for routine maintenance. A minimum of 0.75m of working space around the motor is recommended. Adequate space around the motor, particularly at the fan inlet (50 mm), is also necessary to facilitate airflow.

Where several FC motors are installed in close proximity, care must be taken to ensure that there is no recirculation of exhausted warm air. Foundations must be solid, rigid and level.



NB!

Electrical installation

Do not remove the top foil inside the inverter part, as this is a part of the protective arrangements.

Fitting pinions, pulleys and couplings.

These should be bored to our standard limits and fitted on the shaft with a screwing motion. Attention must be paid to correct guarding of all moving parts.



Tapping of fittings onto the FC motor shaft, with a hammer or mallet, causes bearing damage. This results in an increase in bearing noise and a significant reduction in bearing life.



NB!

Max. length of mounting bolts penetrating the B14 flange, see section *Dimensions* in this chapter.

■ Alignment

When the application calls for direct coupling, the shafts must be correctly aligned in all three planes. Bad alignment can be a major source of noise and vibration.

Allowance must be made for shaft endfloat and thermal expansion in both axial and vertical planes. It is preferable to use flexible drive couplings.

Maximum permissible axial and radial loads in N

| Frame size | Poles | Axial load in [N] | | Radial load in [N] at 0.5 X shaft length |
|------------|-------|-------------------|------|--|
| | | Horizontal shaft | | |
| 80 | 2 | 570 | 610 | |
| 80 | 4 | 760 | 770 | |
| 90 | 2 | 600 | 650 | |
| 90 | 4 | 810 | 820 | |
| 100 | 2 | 830 | 890 | |
| 100 | 4 | 1120 | 1160 | |
| 112 | 2 | 820 | 890 | |
| 112 | 4 | 1100 | 1110 | |
| 132 | 2 | 1300 | 1440 | |
| 132 | 4 | 1710 | 1780 | |

All figures are based on L10 bearing life of 20,000 hours, standard bearings.
Reinforced bearings available.

■ Bolt torques

Endshields and lid should be secured with the bolt sizes and torque's detailed in the table below.

Endshield fixing bolt torques

| FCM Type | Frame size | Bolt diameter | Torque |
|----------|------------|---------------|--------|
| | | Nm. | |
| 305-307 | 80 | M5 | 5 |
| 311-315 | 90 | M5 | 5 |
| 322-330 | 100 | M6 (taptite) | 8-10 |
| 340 | 112 | M6 (taptite) | 8-10 |
| 355-375 | 132 | M8 (taptite) | 29 |

LID screws torque: 2.2 - 2.4 Nm

■ Maintenance

Routine cleaning of the FC motor

Remove the fan cover and ensure that all air inlet holes are completely free. Clean any dirt and obstructions from behind the fan and along the ribs of the frame, and between the motor and inverter part.

Periodic maintenance of motor part.

- a. Remove the inverter part, the fan cover and the fan which is keyed to the shaft extension. Loosen and remove bearing cover screws and endshield bolts/studs. The endshields should then be eased off their spigots.
- b. The rotor can now be carefully withdrawn from the stator, taking care not to damage the stator bore and both stator and rotor windings.
- c. Having dismantled the motor, maintenance can be carried out to remove all dirt. For this purpose, the use of an air line supplying dry compressed air under comparatively low pressure is best, as a high velocity air-stream can force dirt into the spaces between the windings and insulation, etc. Grease-removing solvents can cause damage to impregnating varnish or insulation
- d. The FC-motor should be re-assembled in the reverse order from dismantling, remembering to ease endshields onto bearings and spigots. **DO NOT USE FORCE.**
- e. Before starting, check that the rotor revolves freely. Ensure that the electrical connections are correct.
- f. Refit any pulley, coupling, sprocket etc. which has been removed, being particularly careful to ensure correct alignment with the

driven part, as misalignment will lead to ultimate bearing trouble and shaft breakage.

- g. When replacing screws and bolts, care should be taken to use only those with the requisite quality and tensile strength recommended by the manufacturer. These must also be of identical thread form and screw/bolt length (see the table above).

■ Forced ventilation (FV) units

In some applications the fan built on to the motor shaft do not give sufficient cooling for operation at low speed. That problem is solved by mounting a FV unit.

Typical applications are for example conveyors, spindles and other constant torque (CT) applications

where the customer wants a wide control range without reduction in torque down to low speed.

The VLT Drive Motor yields full continuous torque down to low speed with FV built on. The forced vent enclosure is IP 66. Approved according to UL.

■ Voltage range for forced ventilation (FV) unit

The FVU can be supplied with a wide range of voltages depending on the way the terminals are connected. Standard is three phase 380-500 V (50 Hz), 380-575

V (60 Hz) with the possibility to connect three phase 220-290 V (50 Hz), 220-332 V (60 Hz) or single phase 230-277 V (50/60 Hz). The capacitor for single phase is mounted inside the terminal box.

■ FCM 300 Thermal Protection

The thermal protection of FC and motor is covered in the following way:

1. Overload situations are handled by the calculated electrical load ($I^2 X t$).
2. Missing ventilation and high ambient temperature is handled by the temperature measurement. The derating for low speed (due to missing ventilation) is not incorporated in the electrical load calculator but taken care of by the temperature measurement. Forced ventilation is thus automatically covered.

Electrical load

The current is measured in the DC link and the estimated load is calculated. The level of the electrical load is set at an output torque of 105%. Above that level a counter is increased, below the level it is decreased. The counter starts at zero. When the counter reaches 100, the unit trips. At 98 the warning indication goes on (LED and status word).

| Load | Time from 0 to 100 | Time from 100 to 0 |
|-------|------------------------|-------------------------|
| 0% | - | 60 sec |
| 20% | - | 100 sec |
| 40% | - | 150 sec |
| 60% | - | 200 sec |
| 80% | - | 250 sec |
| 105% | 900 sec (if over 105%) | 300 sec (if under 105%) |
| 120% | 550 sec | - |
| 140% | 210 sec | - |
| 160% | 60 sec | - |
| >165% | 20 sec | - |

At full AC brake (parameter 400) a load > 165% is simulated => 20 sec to trip.

The value can be read in parameter 527. (LCP:FC thermal)..

Temperature measurement

The temperature measurement is sensing the temperature within the electronics box.'

At warning level => Warning indication goes on (LED and status word) and the unit might trip if the temperature doesn't sink back below warning level within 15 minutes. If the function TEMP.DEP.SW is activated in parameter 412, the switching frequency is decreased gradually down to 2 kHz attempting to decrease the temperature.

Trip level => Immediate trip and alarm indication (LED and status word).

The value can be read in parameter 537 (LCP: Heat sink temp.).

The temperature levels seem to be high, but due to a local heating of the sensor the practical levels of the inside air temperature are approx. 10 deg C lower.

■ Control panel (175N0131)

The FC motor optionally features a Local Control Panel- LCP 2 which makes up a complete interface for operation and monitoring of the FC motor. IP 65 on front.



NB!

The LCP from the VLT 5000 Series (code number 175Z0401) cannot be used for the FC motor. However, the general LCP 2 (code number 175N0131) can be used for both the FCM 300, VLT 2800 and the VLT 5000 Series.

■ LCP installation

The LCP 2 is connected to the terminal X100, 1-4 (see separate instruction MI.03.AX.YY).

1. Service Plug Kit (175N2546) (see section *Service plug kit*) and cabel 175N0162
2. Plug kit (175N2545) (see section *Plug kit*) and cabel 175N0162
3. Remote mounting kit (175N0160) (see section *Remote mounting kit*)

■ LCP functions

The functions of the control panel can be divided into three groups:

- display
- keys for changing program parameters
- keys for local operation

All data are indicated by means of a 4-line alphanumeric display, which in normal operation is able show 4 measurements and 3 operating conditions continu-

ously. During programming, all the information required for quick, effective parameter Setup of the FC motor will be displayed. As a supplement to the display, there are three LEDs for voltage, warning and alarm. All program parameters of the FC motor can be changed immediately from the control panel, unless this function has been blocked via parameter 018.

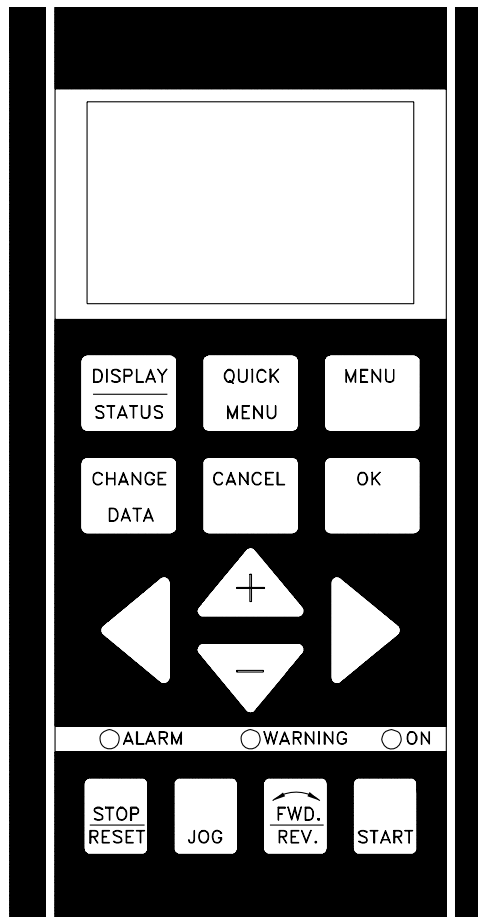

DANFOSS
175ZA004.10

■ Display

The LCD-display has rear lighting and a total of 4 alpha-numeric lines together with a box that shows the direction of rotation (arrow) and the chosen Setup as well as the Setup in which programming is taking place if that is the case.

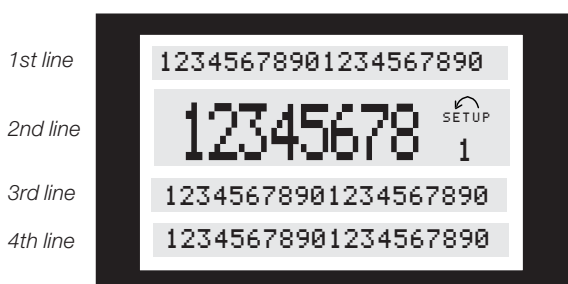

1st line shows up to 3 measurements continuously in normal operating status or a text which explains the 2nd line.

2nd line shows a measurement with related unit continuously, regardless of status (except in the case of alarm/warning).

3rd line is normally blank and is used in the menu mode to show the selected parameter number or parameter group number and name.

4th line is used in operating status for showing a status text or in data change mode for showing the value of the selected parameter.



An arrow indicates the direction of rotation of the motor. Furthermore, the Setup which has been selected as the Active Setup in parameter 004 is shown. When programming another Setup than the Active Setup, the number of the Setup which is being programmed will appear to the right. This second Setup number will flash.

■ LEDs

At the bottom of the control panel is a red alarm LED and a yellow warning LED, as well as a green voltage LED.

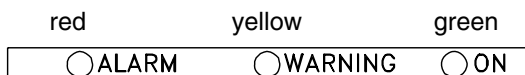

If certain threshold values are exceeded, the alarm and/or warning lamp lights up together with a status and alarm text on the control panel.

The voltage LED is activated when the FC motor receives voltage; at the same time the rear lighting of the display will be on.

■ Control keys

The control keys are divided into functions. This means that the keys between display and indicator LEDs are used for parameter Setup, including choice of display indication during normal operation.

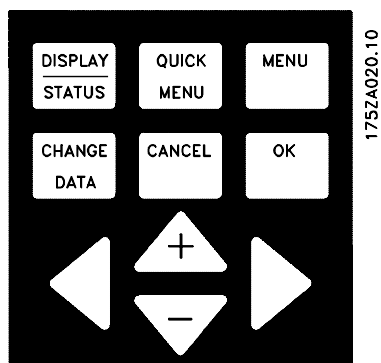

Keys for local control are found under the indicator LEDs.

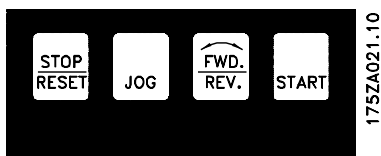

■ Control key functions



[DISPLAY / STATUS] is used for selecting the mode of display or for changing back to Display mode from either the Quick menu mode or the Menu mode.



[QUICK MENU] is used for programming the parameters that belong under the Quick menu mode. It is possible to switch directly between Quick menu mode and Menu mode.



[MENU] is used for programming all parameters. It is possible to switch directly between Menu mode and Quick menu mode.



[CHANGE DATA] is used for changing the parameter selected either in the Menu mode or the Quick menu mode.



[CANCEL] is used if a change of the selected parameter is not to be carried out.



[OK] is used for confirming a change of the parameter selected.



[+/-] is used for selecting parameter and for changing the chosen parameter or for changing the read out in line 2.

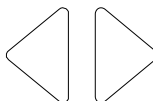

[<>] is used for selecting group and to move the cursor when changing numerical parameters.



[STOP / RESET] is used for stopping or for resetting the FC motor after a drop-out (trip). Can be selected via parameter 014 to be active or inactive. If stop is activated, line 2 will flash, and [START] must be activated.



NB!

Pressing [STOP/RESET] will prevent motor from running also with disconnected LCP 2. Restarting is only possible via the LCP 2 [START] key.

Installation



[JOG] overrides the output frequency to a preset frequency while the key is kept down. Can be selected via parameter 015 to be active or inactive.



[FWD / REV] changes the direction of rotation of the motor, which is indicated by means of the arrow on the display although only in Local. Can be selected via parameter 016 to be active or inactive (parameter 013 must be set to [1] or [3] and parameter 200 set to [1].



[START] is used for starting the FC motor after stop via the [Stop] key. Is always active, but cannot override a stop command given via the terminal strip.



NB!

If the keys for local control have been selected as active, they will remain active both when the frequency has been set for *Local Control* and for *Remote Control* via parameter 002, although with the exception of [FWD/REV], which is only active in Local operation.



NB!

If no external stop function has been selected and the [STOP] key has been selected as inactive via parameter 014, the FC motor can be started and can only be stopped by disconnecting the voltage to the motor.

■ Display read-out state

The display read-out state can be varied - see the list on page 32 - depending on whether the FC motor is in normal operation or is being programmed.

■ Display mode

In normal operation, up to 4 different operating variables can be indicated continuously: 1,1 and 1,2 and 1,3 and 2, and in line 4 the present operating status or alarms and warnings that have arisen.



■ Display mode - selection of read-out state

There are three options in connection with the choice of read-out state in the Display mode - I, II and III. The choice of read-out state determines the number of operating variables read out.

| Read-out state: | I: | II: | III: |
|-----------------|--|--|---|
| Line 1 | Description for operating variable in line 2 | Data value for 3 operating variables in line 1 | Description for 3 operating variables in line 1 |

The table below gives the units linked to the variables in the first and second line of the display (see parameter 009).

| Operating variable: | Unit: |
|--------------------------|---------------|
| Reference | [%] |
| Reference | [unit]* |
| Feedback | [unit]* |
| Frequency | [Hz] |
| Frequency x scaling | [-] |
| Motor current | [A] |
| Torque | [%] |
| Power | [kW] |
| Power | [HP] |
| Motor voltage | [V] |
| DC-link voltage | [V] |
| FC thermal | [%] |
| Hours run | [Hours] |
| Input status, dig. Input | [Binary code] |
| External reference | [%] |
| Status word | [Hex] |
| Heat sink temp. | [°C] |
| Alarm word | [Hex] |
| Control word | [Hex] |
| Warning word 1 | [Hex] |
| Warning word 2 | [Hex] |
| Analog input 1 | [mA] |
| Analog input 2 | [V] |

*) Select in parameter 416. The unit is shown in readout state 1 line 1 otherwise 'U' is shown.

Operating variables 1,1 and 1,2 and 1,3 in the first line, and operating variable 2 in the second line are selected via parameter 009, 010, 011 and 012.

- Read-out state I:

This read-out state is standard after starting up or after initialisation.

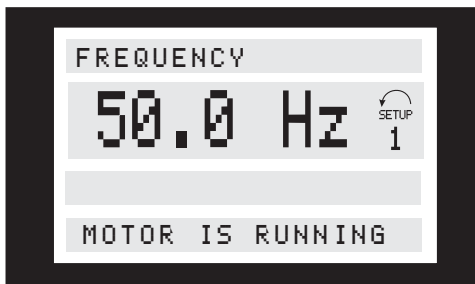

Line 2 gives the data value of an operating variable with related unit, and line 1 provides a text which explains line 2, cf. table. In the example, Frequency has been selected as variable via parameter 009. During normal operation another variable can immediately be read out by using the [+/-] keys.

- Read-out state II:

Switching between read-out states I and II is effected by pressing the [DISPLAY / STATUS] key.

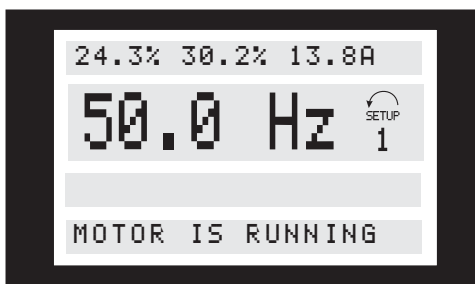

In this state, data values for four operating values are shown at the same time, giving the related unit, cf. table. In the example, Reference, Torque, Current and Frequency are selected as variables in the first and second line.

- Read-out state III:

This read-out state can be held as long as the [DISPLAY/STATUS] key is pressed. When the key is released, the system switches back to Read-out state II, unless the key is pressed for less than approx. 1 sec.

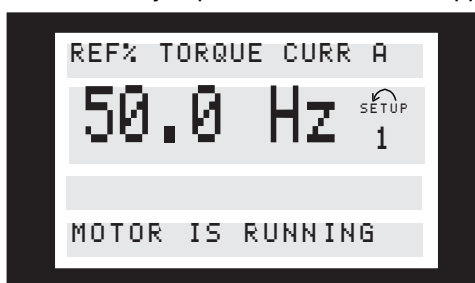

This is where parameter names and units for operating variables in the first line are given - operating variable 2 remains unchanged.

■ Quick menu mode versus Menu mode

The FC motor series can be used for practically all assignments, which is why the number of parameters is quite large. Also, this series offers a choice between two programming modes - a Menu mode and a Quick menu mode.

- The Quick menu takes the user through a number of parameters that may be enough to get the motor to run nearly optimally, if the factory setting for the other parameters takes the desired control functions into account, as well as the configuration of signal inputs/outputs (control terminals).
- The Menu mode makes it possible to select and change all parameters at the user's option. However, some parameters will be "missing", depending on the choice of configuration (parameter 100), e.g. open loop hides all the PID parameters.

In addition to having a name, each parameter is linked up with a number which is the same regardless of the programming mode. In the Menu mode, the parameters are divided into groups, with the first digit of the parameter number (from the left) indicating the group number of the parameter in question.

Regardless of the mode of programming, a change of a parameter will take effect and be visible both in the Menu mode and in the Quick menu mode.

■ Quick Setup via Quick menu

The Quick Setup starts with pressing the [QUICK MENU] key, which brings out the following read-out on the display:



At the bottom of the display, the parameter number and name are given together with the status/value of the first parameter under Quick Setup. The first time the [Quick Menu] key is pressed after the unit has been switched on, the read-outs will always start at pos. 1 - see table below.

■ Parameter selection

The selection of parameter is effected by means of the [+/-] keys. The following parameters are accessible:

| Pos.: | No.: | Parameter: | Unit: |
|-------|------|-----------------------|--------|
| 1 | 001 | Language | |
| 2 | 200 | Direction of rotation | |
| 3 | 101 | Torque characteristic | |
| 4 | 204 | Min. reference | [Hz] |
| 5 | 205 | Max. reference | [Hz] |
| 6 | 207 | Ramp up time | [sec.] |
| 7 | 208 | Ramp down time | [sec.] |
| 8 | 002 | Local/remote control | |
| 9 | 003 | Local reference | |
| 10 | 500 | Bus address | |

■ Menu mode

The Menu mode is started by pressing the [MENU] key, which produces the following read-out on the display:

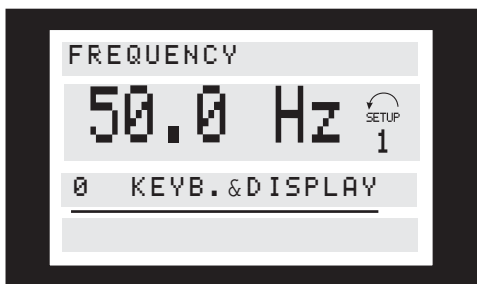

Line 3 on the display shows the parameter group number and name.

■ Parameter groups

In the Menu mode the parameters are divided into groups. Selection of parameter group is effected by means of the [<>] keys.

The following parameter groups are accessible:

| Group no. | Parameter group: |
|-----------|----------------------|
| 0 | Operation & Display |
| 1 | Load & Motor |
| 2 | References & Limits |
| 3 | Inputs & Outputs |
| 4 | Special functions |
| 5 | Serial communication |
| 6 | Technical functions |

*For information on parameter group 800 and 900 for PROFIBUS, please see the FCM Profibus manual MG.03.EX.YY.

When the desired parameter group has been selected, each parameter can be chosen by means of the [+/-] keys:

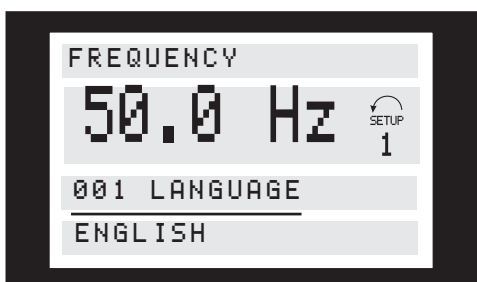

The 3rd line of the display shows the parameter number and name, while the status/value of the selected parameter is shown in line 4.

■ Changing data

Regardless of whether a parameter has been selected under the Quick menu or the Menu mode, the procedure for changing data is the same. Pressing the [CHANGE DATA] key gives access to changing the selected parameter, following which the underlining in line 4 will flash on the display. The procedure for changing data depends on whether the selected parameter represents a numerical data value or a text value.

■ Changing a text value

If the selected parameter is a text value, the text value is changed by means of the [+/-] keys.

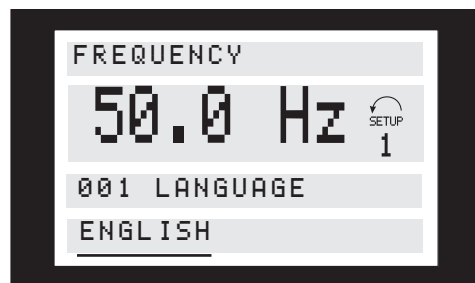

The bottom display line shows the text value that will be entered (saved) when acknowledgement is given [OK].

■ Infinitely variable change of numeric data value

If the chosen parameter represents a numeric data value, a digit is first selected by means of the [<>] keys.

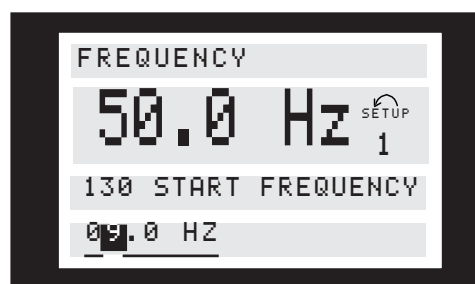

Then the chosen digit is changed infinitely variably by means of the [+/-] keys:

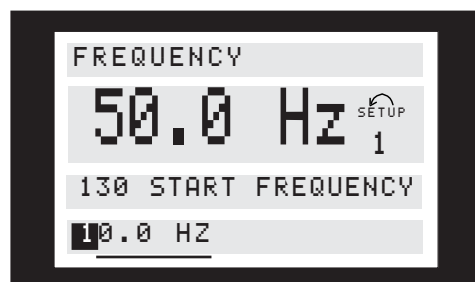

The chosen digit is indicated by the digit flashing. The bottom display line shows the data value that will be entered (saved) when signing off with [OK].

■ Menu structure

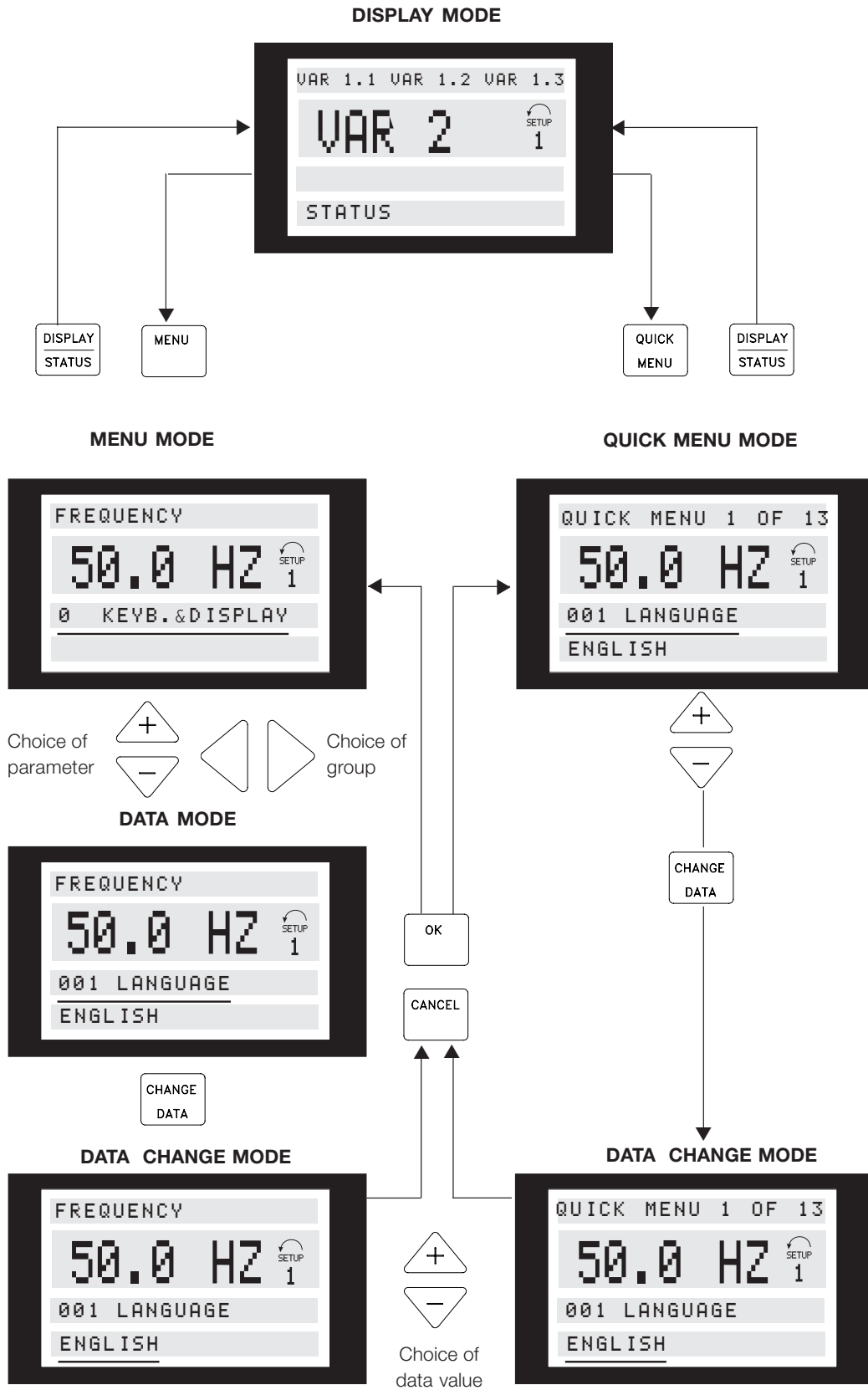

175ZA446.11

VLT® FCM Series

■ Service plug kit (175N2546)

Purpose:

To run LCP2 and PROFIBUS at the same time. The service plug can be used with FCM 300 of serial number 03Gxxx and software version as from 2.03. Used together with cable for plug kit 175N0162.

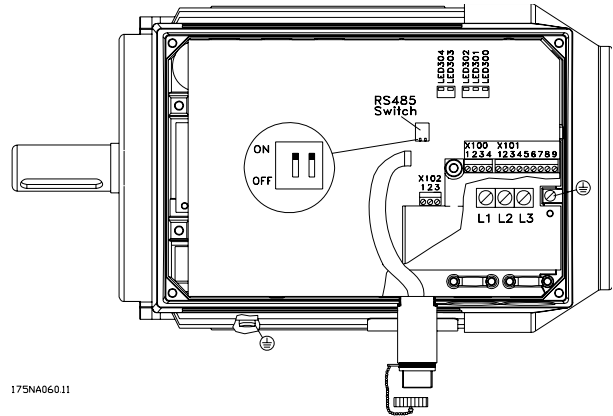

■ Plug kit (175N2545)

Purpose

To make a plugable connection between LCP 2 and FCM 300.

Used together with cable for plug kit 175N0162.

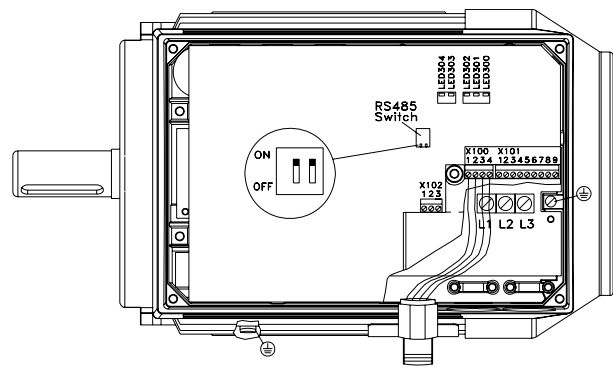

Installation

■ Remote mounting kit (175N0160)

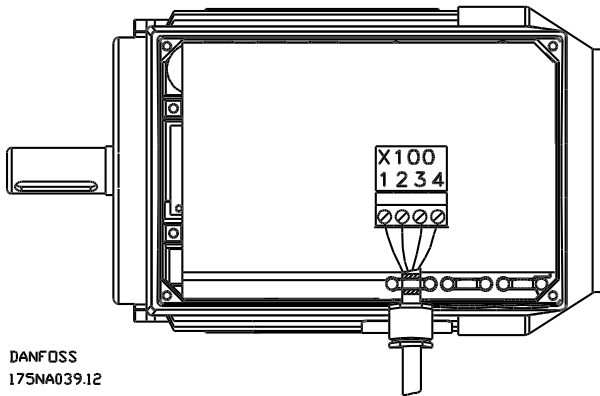

Connections

| Colour of wire/ | Terminal X100/ | D-sub pin |
|-----------------|----------------|-----------|
| yellow | 1 | 8 |
| green | 2 | 9 |
| red | 3 | 2 |
| blue | 4 | 3 |

■ Remote mounting kit cont.

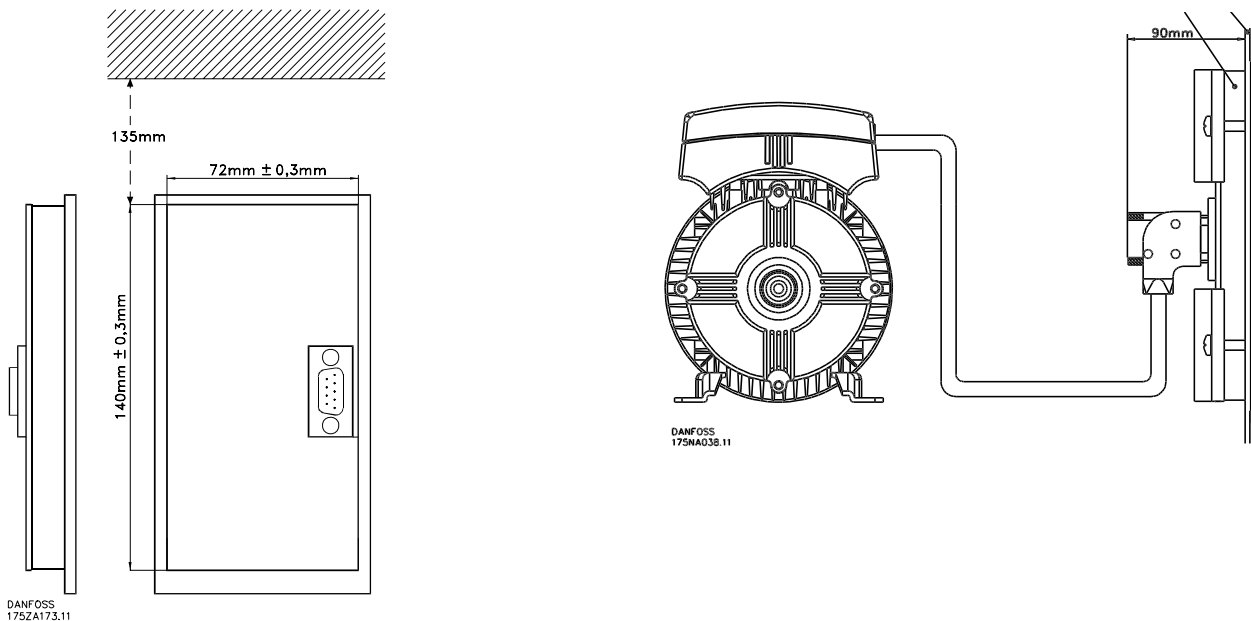

■ Potentiometer option (177N0011)

Option to control the reference by means of a potentiometer. The option is mounted instead of a cable bracket. The potentiometer is operated by removing the blind plug to set the desired reference, and then mount the blind plug again.

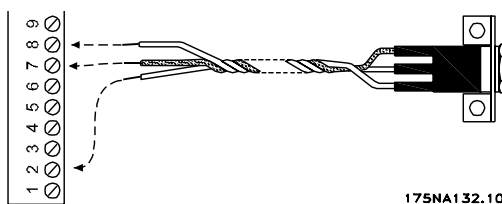

175NA132.10

| Colour of wire | Terminal on X101 |
|----------------|------------------|
| White | 2 (analog input) |
| Red | 8 (0 V) |
| Black | 7 (+10 V) |

■ Local Operation Pad (LOP) (175N0128) IP65

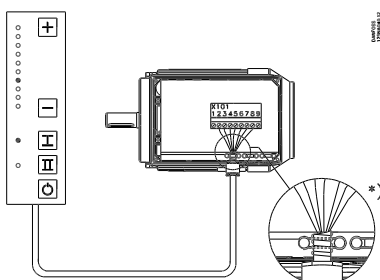

Wiring

| Colour of wire | Terminal | Function |
|------------------|----------|------------------------|
| White | 2 | Reference |
| Brown | 3 | Reset |
| Purple * or Grey | 4 | See table under button |
| Green | 5 | See table under button |
| Red | 6 | +24V |
| Yellow | 7 | +10V |
| Blue | 8 | Ground |

* Can be orange in some cables

Local Operation Panel (LOP) 175N0128 IP 65

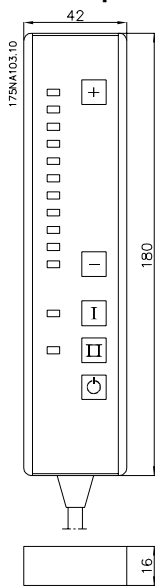

Fixture for LOP 175N2717 (included in 175N0128)

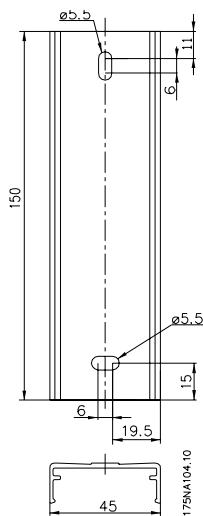

| Functions/settings | Key I (Start) | Key II (Start) | ⏻ Key (Stop) |
|---|----------------------------|--------------------------|-----------------------------|
| Default - Dual speed operation (connect purple wire): No changes to factory setting. | Run on set reference (+/-) | Run on 10 Hz** jog speed | Stop (and reset* - if trip) |
| Function 2 - Dual mode operation (connect purple wire) Select desired modes of operation in Setups 1 and 2 (use para. 4-6) Parameter 335 = 18 (select Setup) | Run with Setup 1 | Run with Setup 2 | Stop (and reset* - if trip) |
| Function 3 - Dual direction operation (connect grey wire) Parameter 335 = 10 (start reversing) Parameter 200 = 1 (both directions) | Run forward | Run reverse | Stop (and reset* - if trip) |

*If no reset is required, do not connect the brown wire**or set parameter 213
Use the +/- keys to set reference

At power up the unit will always be in stop mode. Set reference will be stored during power down. If permanent start mode is desired, connect terminal 6 to terminal 4 and do not connect purple/grey wire to terminal 4. This means the stop function on LOP is disabled.



NB!

After fitting, cut off or isolate excess wire.

001 Language (LANGUAGE)

Value:

| | |
|---------------------|-----|
| ★ English (ENGLISH) | [0] |
| German (DEUTSCH) | [1] |
| French (FRANCAIS) | [2] |
| Danish (DANSK) | [3] |
| Spanish (ESPAÑOL) | [4] |
| Italian (ITALIANO) | [5] |

State when delivered may vary from factory setting.

Function:

The choice in this parameter defines the language to be used on the display.

Description of choice:

There is a choice of *English* [0], *German* [1], *French* [2], *Danish* [3], *Spanish* [4] and *Italian* [5].

002 Local/remote control (OPERATION SITE)

Value:

| | |
|---------------------------|-----|
| ★ Remote control (REMOTE) | [0] |
| Local control (LOCAL) | [1] |

Function:

There is a choice of two methods of controlling the FC motor: *Remote control* [0] and *Local control* [1].

Description of choice:

If *Remote control* [0] is selected, the FC motor can be controlled via:

1. The control terminals or the serial communication port .
2. The [START] key. However, this cannot override Stop commands (also start-disable) entered via the digital inputs or the serial communication port.
3. The [STOP], [JOG] and [RESET] keys, provided that these are active (see parameters 014, 015 and 017).

If *Local control* [1] is selected, the FC motor can be controlled via:

1. The [START] key. However, this cannot override Stop commands on the digital terminals

(if [2] or [4] has been selected in parameter 013).

2. The [STOP], [JOG] and [RESET] keys, provided that these are active (see parameters 014, 015 and 017).
3. The [FWD/REV] key, provided that this has been activated in parameter 016 and that in parameter 013 a choice of [1] or [3] has been made.
4. Via parameter 003 the local reference can be controlled by means of the "Arrow up" and "Arrow down" keys.

003 Local reference (LOCAL REFERENCE)

Value:

Par 013 set for [1] or [2]:

0 - f_{MAX} ★ 000.000

Par 013 set for [3] or [4] and par. 203

= [0] set for:

Ref_{MIN} - Ref_{MAX} ★ 000.000

Par 013 set for [3] or [4] and par. 203

= [1] set for:

-Ref_{MAX} - + Ref_{MAX} ★ 000.000

Function:

This parameter allows manual setting of the desired reference value (speed or reference for the selected configuration, depending on the choice made in parameter 013).

The unit follows the configuration selected in parameter 100, provided that *Process regulation, closed loop* [3] has been selected.

Description of choice:

Local [1] must be selected in parameter 002 for this parameter to be used.

The set value is saved in the case of a voltage dropout, see parameter 019.

In this parameter Data Change Mode is not exited automatically (after time out).

Local reference cannot be set via the serial communication port.



Warning: Since the value set is remembered after the power has been cut, the motor may start without warning when the power is reinstated; if parameter 019 is changed to *Auto restart, use saved ref.* [0].

004 Active Setup (ACTIVE SETUP)

Value:

| | |
|-------------------------------|-----|
| Factory Setup (FACTORY SETUP) | [0] |
| ★ Setup 1 (SETUP 1) | [1] |
| Setup 2 (SETUP 2) | [2] |
| Multi Setup (MULTI SETUP) | [5] |

Function:

The choice in this parameter defines the Setup number you want to control the functions of the FC motor.

All parameters can be programmed in two individual parameter Setups, Setup 1 and Setup 2. In addition, there is a pre-programmed Setup, called Factory Setup, that cannot be modified.

Description of choice:

Factory Setup [0] contains the factory data. Can be used as a data source if the other Setups are to be returned to a known state.

Parameters 005 and 006 allow copying from one Setup to the other.

Setups 1 [1] and *2* [2] are two individual Setups that can be selected as required.

Multi-Setup [5] is used if remote-mounting switching between Setups is desired. Terminals 2, 3, 4, and 5 as well as the serial communication port can be used for switching between Setups.

005 Programming Setup (EDIT SETUP)

Value:

| | |
|-------------------------------|-----|
| Factory Setup (FACTORY SETUP) | [0] |
| Setup 1 (SETUP 1) | [1] |
| Setup 2 (SETUP 2) | [2] |
| ★ Active Setup (ACTIVE SETUP) | [5] |

Function:

The choice is of the Setup in which programming (change of data) is to occur during operation. It is possible to programme the two Setups independently of the Setup selected as the Active Setup (selected in parameter 004).

Description of choice:

The *Factory Setup* [0] contains the factory data and can be used as a data source if the other Setups are to be returned to a known state.

Setups 1 [1] and *2* [2] are individual Setups which can be used as required. They can be programmed freely, regardless of the Setup selected as the Active Setup and thus controlling the functions of the FC motor.



NB!

If a general change of data or a copying to the Active Setup is effected, this immediately affects the functioning of the unit.

006 Copying of Setups (SETUP COPY)

Value:

| | |
|--|-----|
| ★ No copying (NO COPY) | [0] |
| Copy to Setup 1 from # (COPY TO SETUP 1) | [1] |
| Copy to Setup 2 from # (COPY TO SETUP 2) | [2] |
| Copy to Setup all from # (COPY TO ALL) | [5] |

= the Setup selected in parameter 005

Function:

A copy is made from the Setup selected in parameter 005 to one of the other Setups or to all the other Setups simultaneously.



NB!

Copying is only possible in Stop Mode (motor stopped on a Stop command). Copying will take max. 3 seconds and has ended when parameter 006 has returned to value 0.

007 LCP copy (LCP COPY)

Value:

| | |
|--|-----|
| ★ No copying (NO COPY) | [0] |
| Upload all parameters (UPLOAD ALL PARAM) | [1] |
| Download all parameters (DOWNLOAD ALL) | [2] |
| Download power-independent par. (DOWNLOAD SIZE INDEP.) | [3] |

Function:

Parameter 007 is used if it is desired to use the integrated copying function of the control panel. You can therefore easily copy parameter value(s) from one FC motor to another.

Description of choice:

Select *Upload all parameters* [1] if all parameter values are to be transmitted to the control panel. Select *Download all parameters* [2] if all transmitted parameter values are to be copied to the FC motor on which the control panel has been mounted. Select *Download power-independent par.* [3] if only the power-independent parameters are to be downloaded. This is used if downloading to a FC motor that has a different rated power than the one from where the parameter Setup originates.



NB!

Uploading/Downloading can only be carried out in the Stop mode and only between units with the same major data-base version (see par. 626 value major.minor)

008 Display scaling of motor frequency (FREQUENCY SCALE)

Value:

0.01 - 100.00 [1 - 10000]

★ 1.00 [100]

Function:

This parameter chooses the factor to be multiplied by the motor frequency, f_M , for presentation in the display, when parameters 009-012 have been set for Frequency x Scaling [5].

Description of choice:

Set the desired scaling factor.

009 Display line 2 (DISPLAY LINE 2)

Value:

None [0]

Reference [%] (REFERENCE [%]) [1]

Reference [unit] (REFERENCE [UNIT]) [2]

Feedback [unit] (FEEDBACK [UNIT]) [3]

★ Frequency [Hz] (FREQUENCY [Hz]) [4]

Frequency x Scaling [-] (FREQUENCY X SCALE) [5]

Motor current [A] (MOTOR CURRENT [A]) [6]

Torque [%] (TORQUE [%]) [7]

Power [kW] (POWER [kW]) [8]

Power [HP] (POWER [hp] [US]) [9]

| | |
|---|------|
| Motor voltage [V] (MOTOR VOLTAGE [V]) | [11] |
| DC link voltage [V] (DC LINK VOLTAGE [V]) | [12] |
| Thermal load, FC [%] (FC THERMAL [%]) | [14] |
| Hours run [Hours] (RUNNING HOURS) | [15] |
| Digital input [Binary code] (DIGITAL INPUT [BIN]) | [16] |
| External reference [%] (EXTERNAL REF [%]) | [21] |
| Status word [Hex] (STATUS WORD [HEX]) | [22] |
| Heat sink temp. [°C] (HEATSINK TEMP [°C]) | [25] |
| Alarm word [Hex] (ALARM WORD [HEX]) | [26] |
| Control word [Hex] (CONTROL WORD [HEX]) | [27] |
| Warning word 1 [Hex] (WARNING WORD 1 [HEX]) | [28] |
| Warning word 2 [Hex] (EXTENDED STATUS WORD [HEX]) | [29] |
| Analog input 1 [mA] (ANALOG INPUT 1 [mA]) | [30] |
| Analog input 2 [V] (ANALOG INPUT 2 [V]) | [31] |

Function:

This parameter allows a choice of the data value to be displayed in line 2 of the display.

Parameters 010-012 enable the use of three additional data values to be displayed in line 1.

For display read-outs, press the [DISPLAY/STATUS] button, see also page 31.



NB!

In parameter 009, "none" [0] cannot be selected.

Description of choice:

Reference [%] corresponds to the total reference (sum of digital/analogue/preset/bus/freeze ref./ catch-up and slow-down).

Reference [unit] gives the sum of the references using the unit stated on the basis of configuration in parameter 100 (Hz, Hz and rpm).

Feedback [unit] gives the status value of terminal 1 and 2 using the unit/scale selected in parameter 414, 415 and 416.

Frequency [Hz] gives the motor frequency, i.e. the output frequency to the motor.

Frequency x Scaling [-] corresponds to the present motor frequency f_M multiplied by a factor (scaling) set in parameter 008.

Motor current [A] states the phase current of the motor measured as effective value.

Torque [%] gives the current motor load in relation to the rated motor torque.

Power [kW] states the actual power consumed by the motor in kW.

Power [HP] states the actual power consumed by the motor in HP.

Motor voltage [V] states the voltage supplied to the motor.

DC link voltage [V] states the intermediate circuit voltage in the FC motor.

Thermal load, FC [%] states the calculated/ estimated thermal load on the FC motor. 100% is the cut-out limit.

Hours run [Hours] states the number of hours that the motor has run since the latest reset in parameter 619.

Digital input [Binary code] states the signal states from the 4 digital terminals (2, 3, 4 and 5). Input 5 corresponds to the bit at the far left. '0' = no signal, '1' = connected signal.

External reference [%] gives the sum of the external reference as a percentage (the sum of analogue/ pulse/bus).

Status word [Hex] gives the status word sent via the serial communication port in Hex code from the FC motor.

Heat sink temp. [°C] states the present heat sink temperature of the FC motor. The cut-out limit is $90 \pm 5^\circ\text{C}$; cutting back in occurs at $60 \pm 5^\circ\text{C}$.

Alarm word [Hex] indicates one or several alarms in a Hex code. See page 74.

Control word [Hex] indicates the control word for the FC motor. See Serial communication.

Warning word 1 [Hex] indicates one or more warnings in a Hex code. See page 74 for further information.

Extended status word [Hex] indicates one or more status states in a Hex code. See page 74 for further information.

Analog input 1 [mA] states the signal value on terminal 1.

Analog input 2[V] states the signal value on terminal 2.

010 Display line 1.1 (DISPLAY LINE 1.1)

Value:

★ Reference [%] [1]

See parameter 009.

Function:

This parameter enables a choice of the first of three data values to be shown on the display, line 1, position 1.

Description of choice:

There is a choice of 24 different data values, see parameter 009.

011 Display line 1.2 (DISPLAY LINE 1.2)

Value:

★ Motor current [A] [1]

See parameter 009

Function:

This parameter enables a choice of the second of the three data values to be shown on the display, line 1, position 2.

For Display read-outs, press the [DISPLAY/STATUS] button, see also page 31.

Description of choice:

There is a choice of 24 different data values, see parameter 009.

012 Display line 1.3 (DISPLAY LINE 1.3)

Value:

★ Power [kW] [8]

See parameter 009

Function:

This parameter enables a choice of the third of the three data values to be shown on the display, line 1, position 3.

Display read-outs are made by pressing the [DISPLAY/STATUS] button, see also page 31.

Description of choice:

There is a choice of 24 different data values, see parameter 009.

013 Local Control/Configuration as parameter 100 (LOCAL CTRL/CONFIG.)

Value:

Local not active (DISABLE) [0]

LCP control and open loop.

(LCP CTRL/OPEN LOOP) [1]

- LCP digital control and open loop.
(LCP+DIG CTRL/OP.LOOP) [2]
- LCP control/as parameter 100.
(LCP CTRL/AS P100) [3]
- ★ LCP digital control/as parameter 100.
(LCP+DIG CTRL/AS P100) [4]

Function:

This is where the desired function is to be selected if Local control has been chosen in parameter 002. See also the description of parameter 100.

Description of choice:

If *Local not active* [0] is selected, a possible setting of *Local reference via parameter* 003 is blocked. It is only possible to change to *Local not active* [0] from one of the other setting options in parameter 013, when the FC motor has been set to *Remote control* [0] in parameter 002.

LCP control and open loop [1] is used when the speed is to be adjustable (in Hz) via parameter 003, when the FC motor has been set to *Local control* [1] in parameter 002.

If parameter 100 has not been set to *Speed regulation open loop* [0], switch to *Speed regulation open loop* [0].

LCP digital control and open loop [2] functions as *LCP control and open loop* [1], the only difference being that when parameter 002 has been set to *Local operation* [1], the motor is controlled via the digital inputs.

LCP control/as parameter 100 [3] is selected if the reference is to be set via parameter 003.

LCP digital control/as parameter 100 [4] functions as *LCP control/as parameter 100* [3], although, when parameter 002 has been set to *Local operation* [1], the motor may be controlled via the digital inputs.



NB!

Shift from Remote control to LCP digital control and open loop:

The present motor frequency and direction of rotation must be maintained. If the present direction of rotation does not correspond to the reversing signal (negative reference), the motor frequency f_M will be set at 0 Hz.

Shift from LCP digital control and open loop to Remote control:

The selected configuration (parameter 100) will be active. Shifts are effected without any abrupt movement.

Shift from Remote control to LCP control/as parameter 100 or LCP digital control/as parameter 100.

The present reference will be maintained. If the reference signal is negative, the local reference will be set at 0.

Shift from LCP control/as parameter 100 or LCP remote control as parameter 100 to Remote control.

The reference will be replaced by the active reference signal from the remote control..

014 Local stop

(LOCAL STOP)

Value:

- Not possible (DISABLE) [0]
- ★ Possible (ENABLE) [1]

Function:

This parameter disables/enables the local stop function in question from the control panel. This key is used when parameter 002 has been set for *Remote control* [0] or *Local* [1].

Description of choice:

If *Disable* [0] is selected in this parameter, the [STOP] key will be inactive.



NB!

If *Enable* is selected, the [STOP] key overrules all Start commands.

015 Local jog

(LOCAL JOGGING)

Value:

- ★ Not possible (DISABLE) [0]
- Possible (ENABLE) [1]

Function:

In this parameter, the jog function can be enabled/ disabled on the control panel.

Description of choice:

If *Disable* [0] is selected in this parameter, the [JOG] key will be inactive.

016 Local reversing

(LOCAL REVERSING)

Value:

- ★ Not possible (DISABLE) [0]

Possible (ENABLE) [1]

Function:

In this parameter, the reversing function can be enabled/disabled on the control panel. This key can only be used if parameter 002 has been set to *Local operation* [1] and parameter 013 to *LCP control with open loop* [1] or *LCP control as parameter 100* [3].

Description of choice:

If *Disable* [0] is selected in this parameter, the [FWD/REV] key will be inactive. See parameter 200.

017 Local reset of trip

(LOCAL RESET)

Value:

Not possible (DISABLE) [0]
 ☆ Possible (ENABLE) [1]

Function:

In this parameter, the reset function can be selected/removed from the keyboard. This key can be used when parameter 002 has been set for *Remote control* [0] or *Local control* [1].

Description of choice:

If *Disable* [0] is selected in this parameter, the [RESET] key will be inactive.



NB!

Only select *Disable* [0] if an external reset signal has been connected via the digital inputs.

018 Lock for data change

(DATA CHANGE LOCK)

Value:

☆ Not locked (NOT LOCKED) [0]
 Locked (LOCKED) [1]

Function:

In this parameter, the software can "lock" the control, which means that data changes cannot be made via LCP 2 (however, this is still possible via the serial communication port).

Description of choice:

If *Locked* [1] is selected, data changes cannot be made.

019 Operating state at power up, local control

(POWER UP ACTION)

Value:

Auto restart, use saved ref. (AUTO RE-START) [0]
 ☆ Forced stop, use saved ref. (LOCAL=STOP) [1]
 Forced stop, set ref. to 0 (LOCAL=STOP, REF=0) [2]

Function:

Setting of the desired operating mode when the mains voltage is reconnected.

This function can only be active in connection with *Local control* [1] in parameter 002.

Description of choice:

Auto restart, use saved ref. [0] is selected if the unit is to start up with the same local reference (set in parameter 003) and the same start/stop conditions (given via the [START/STOP] keys) that the FC motor had before it was switched off.

Forced stop, use saved ref. [1] is used if the unit is to remain stopped when the mains voltage is connected, until the [START] key is pressed. After the start command, the local reference used is set in parameter 003. *Forced stop, set ref. to 0* [2] is selected if the unit is to remain stopped when the mains voltage is connected. Local reference (parameter 003) is reset.



NB!

In remote controlled operation (parameter 002), the start/stop condition at power up will depend on the external control signals. If *Latched start* is selected in parameter 332-335, the motor will remain stopped at power up.

100 Configuration (CONFIG. MODE)

Value:

- ★ Speed, open loop mode (SPEED OPEN LOOP) [0]
- Process, closed loop mode (PROCESS CLOSED LOOP) [1]

Function:

This parameter is used for selecting the configuration to which the FC motor is to be adapted.

Description of choice:

If *Speed, open loop mode* [0] is selected, a normal speed control (without feedback signal) is obtained, but with automatic slip compensation, ensuring a nearly constant speed at varying loads. Compensations are active, but may be disabled as required in parameter 133 - 136.

If *Process, closed loop mode* [3] is selected, the internal process regulator will be activated, thereby enabling accurate regulation of a process with respect to a given process signal. The process signal can be set using the actual process unit or as a percentage. A feedback signal must be supplied from the process, and the process setpoint must be adjusted. In process closed loop both directions is not allowed in parameter 200.



NB!

This is only possible in Stop Mode (motor stopped on a Stop command).

101 Torque characteristics (TORQUE CHARACT)

Value:

- ★ Constant torque (CONSTANT TORQUE) [1]
- Variable torque: low (VAR.TORQUE: LOW) [2]
- Var. torque: medium (VAR.TORQUE: MEDIUM) [3]
- Variable torque: high (VAR.TORQUE: HIGH) [4]

Function:

In this parameter, the principle for adjusting the U/f characteristics of the FC motor to the torque characteristics of the load is selected.

Description of choice:

If *Constant torque* [1] is selected, a load-dependent U/f characteristic is obtained in which the output voltage is increased in the case of an increasing load (current) so as to maintain constant magnetisation of the motor. Select *Variable torque low* [2], *Variable torque medium* [3] or *Variable torque high* [4] if the load is square (centrifugal pumps, fans).

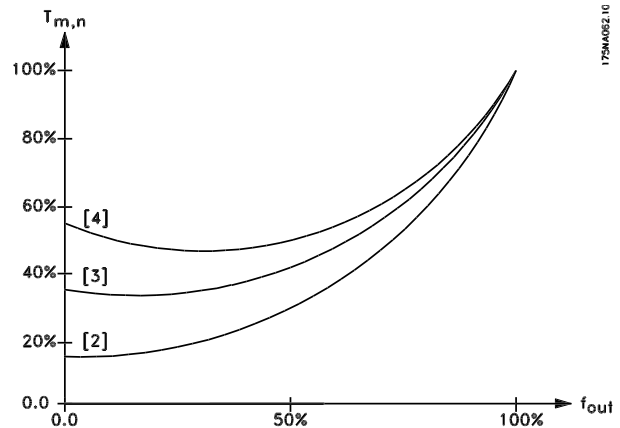

NB!

Slip compensation (parameter 136) and start (parameter 134) are not active if a variable torque is used.

102 Motor power (MOTOR POWER)

Value:

XX.XX kW - depends on the FC motor [XXXX]

Function:

Read only parameter.

103 Motor voltage (MOTOR VOLTAGE)

Value:

XX V- depends on the FC motor [XX]

Function:

Read only parameter.

104 Motor frequency (MOTOR FREQUENCY)

Value:

XX.X Hz - depends on the FC motor [XXX]

Function:

Read only parameter.

**105 Motor current
(MOTOR CURRENT)**

Value:
XX.X X A- depends on the FC motor. [XXXX]

Function:

Read only parameter.

**106 Rated motor speed
(MOTOR NOM. SPEED)**

Value:
XX rpm - depends on the FC motor [XX]

Function:

Read only parameter.

**117 Resonance damping
(RESONANCE DAMP.)**

Value:
OFF - 100% [OFF -100]
★ OFF %. [OFF]

Function:

It is possible to optimise the resonance damping. The grade of the influence is adjusted in this parameter. The value may be set between 0% (OFF) and 100%. 100% corresponds to the unit dependent max. allowed proportional gain. Default value is OFF.



NB!

Vibrations cannot be removed in all cases at no load function or high switching frequency. Vibrations are motor dependent.

Description of functionality:

The system torque is estimated based on the DC-link and fed back to a proportional gain controller. At a unit dependent level of active motor current the controller is disabled.

Description of choice:

Set the grade of proportional gain for the torque feed-back between 0% (OFF) and 100%.

**126 DC braking time
(DC BRAKING TIME)**

Value:
0.0 - 60.0 sec. [0-600]
★ 10.0 sec. [100]
DC braking see P132

Function:

This parameter is for setting the DC braking time for which the DC braking voltage (parameter 132) is to be active.

0.0 sec. = OFF

Description of choice:

Set the desired time.

**127 DC brake cut-in frequency
(DC BRAKE CUT-IN)**

Value:
0.0 - f_{MAX} (parameter 202) [0 -]
0.0 Hz = OFF [0]
DC braking see P132

Function:

This parameter is for setting the DC brake cut-in frequency at which the DC braking voltage (parameter 132) is to be active, in connection with a Stop command.

Description of choice:

Set the desired frequency.

**128 Motor thermal protection
(MOTOR THERM. PROTEC.)**

Value:
★ No protection (NO PROTECTION) [0]

Function:

Read only parameter
Please refer to section *FCM 300 Thermal protection*.

★ = factory setting, () = display text, [] = value for use in communication via serial communication port

132 DC braking voltage

(DC BRAKE VOLTAGE)

Value:

0 - 100 % [0-100]

★ 0 % [0]

Function:

DC braking:

If the stator in an asynchronous is supplied with DC voltage, a braking torque will arise.

The braking torque depends on the selected DC braking voltage.

For applying a braking torque by means of DC braking the rotating field (AC) in the motor is exchanged with a stationary field (DC)

The DC braking will be active when below cut in frequency and stop is activated at the same time. P126, P127 and P132 are used for the control of the DC braking.

The DC braking can also be activated directly by a digital input.

Function:

The braking torque depends on the selected DC braking voltage. The DC braking voltage is stated as a percentage of maximum braking voltage.

Description of choice:

Set the desired voltage as a specified percentage of maximum braking voltage.



NB!

The DC braking voltage cannot be used as a holding brake.

133 Start voltage

(START VOLTAGE)

Value:

0.00 - 100.00 V [0-10000]

★ Depends on motor

Function:

You can set the motor voltage below the field weakening point independently of the motor current. Use this parameter to compensate too low starting torque.

The start voltage is the voltage at 0 Hz.



NB!

If the start voltage is set too high, it can lead to magnetic saturation and motor overheating; the FC motor may trip.

Therefore take care when using the start voltage.

Description of choice:

Set the desired start voltage.

134 Load compensation

(LOAD COMPENSATION)

Value:

0.0 - 300.0 % [0-3000]

★ 100.0 % [1000]

Function:

In this parameter, the load characteristic is set. By increasing the load compensation, the motor is given an extra voltage and frequency supplement at increasing loads. This is used e.g. in motors/applications in which there is a big difference between the full-load current and idle-load current of the motor.



NB!

If the value is too high the FC motor can trip due to overcurrent.

Description of choice:

If the factory setting is not adequate, load compensation must be set to enable the motor to start at the given load.



Should be set to 0% in case of quick load changes. Too high load compensation may lead to instability.

135 U/f ratio

(U/F RATIO)

Value:

0.00 - 20.00 V/Hz [0-2000]

★ Motor dependent

Function:

The output voltage to the motor can be adjusted on a linear basis from 0 to rated frequency.

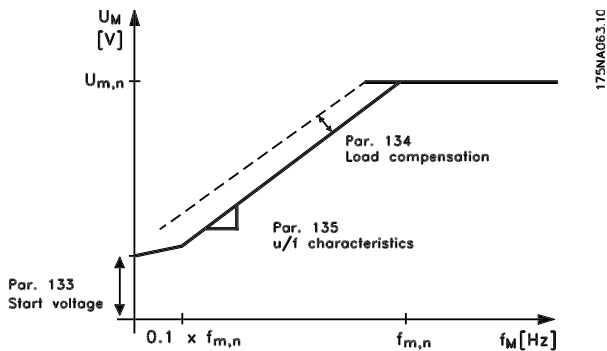

136 Slip compensation (SLIP COMP.)

Value:
 -500.0 - +500.0 % [-5000 - +5000]
 ☆ 100.0 % [1000]

Function:
 The rated slip compensation (factory setting) is calculated on the basis of the motor parameters. In parameter 136 the slip compensation can be adjusted in detail. Optimizing makes the motor speed less load dependent. This function is not active at the same time as variable torque (parameter 101).

Description of choice:
 Enter a % value of rated slip compensation.

137 DC holding voltage (DC HOLD VOLTAGE)

Value:
 0 - 100 % [0-100]
 ☆ 0 (OFF) % [0]

Function:
 This parameter is used to uphold the motor function (holding torque) or to pre-heat the motor. DC holding voltage is active at stopped motor when it is set at a value which is different from 0. Coasting stop will deactivate the function.

Description of choice:
 Enter a percentage value.

138 Brake cut out frequency (BRAKE RELEASE)

Value:

0.5 - 132 Hz (parameter 200) [5-]
 ☆ 3.0 Hz [30]

Function:
 Here the frequency at which the external brake is to be released is selected via output set in parameter 323 or 340 during running.

Description of choice:
 Set desired frequency.

139 Brake cut in frequency at activated stop (BRAKE CUT IN)

Value:
 0.5 - 132 Hz (parameter 200) [5-]
 ☆ 3.0 Hz [30]

Function:
 Here the frequency at which the external brake is to be activated is selected via output set in parameter 323 or 340 when the motor is ramping down to stop.

Description of choice:
 Set the desired frequency.
 See below speed profile for brake function.

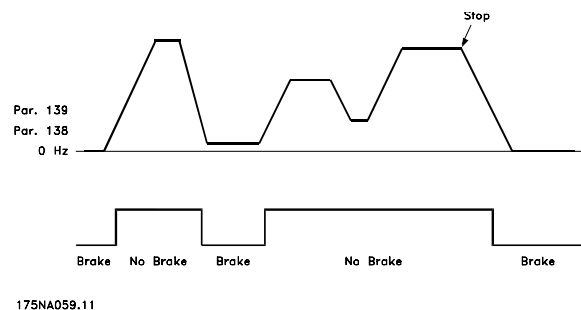

147 Setup of motor type (SETUP OF MOTOR TYPE)

Value:
 Depends on unit

Function:
 This is where to select the specific motor at which the spare part unit is to be installed.

Programming

☆ = factory setting, () = display text, [] = value for use in communication via serial communication port

**NB!**

This parameter will only be changeable in spare part units.

Please check software version number in parameter 624.

If software version = 2.61:

After changing parameter 147, please set parameter 620 to initialize [3] and power off and on again.

If software version > 2.61:

After changing parameter 147, please switch power off and on again.

Please note that the actions above will put the drive into factory settings (except for parameters 500, and 600-605).

Description of choice:

Select the choice of motor according to motor brand, numbers of poles and power size.

Example: ATB STD-4-075 means ATB 4 pole 0.75 kW motor.

| 200 | Rotation direction (ROTATION) |
|---|----------------------------------|
| Value: | |
| ☆ Only clockwise, (Only clockwise) | [0] |
| Both directions, 0-132 Hz (132 Hz BOTH DIRECTIONS) | [1] |
| Only counterclockwise, 0-132 Hz (132Hz COUNTERCLOCKW.) | [2] |

Function:

This parameter guarantees protection against unwanted reversing.

Using *Process, closed loop* mode (parameter 100) parameter 200 must not be changed to *Both directions* [1].

Description of choice:

Select the desired direction seen from the motor drive end.

Note that if *Only clockwise, 0-132 Hz* [0] / *Only counterclockwise, 0-132 Hz* [2] is selected, the output frequency will be limited to the range $f_{MIN} - f_{MAX}$.

If *Both directions, 0-132 Hz* [1] is selected, the output frequency will be limited to the range $\pm f_{MAX}$ (the minimum frequency is of no significance).



NB!

This is only possible in Stop Mode (motor stopped on a Stop command). Ramp will be followed, if no set up change.



NB!

If parameter 200, selection of direction, is set for different values in the 2 setups, and the setup is changed during operation, the direction changes without ramping. In such cases trip may occur and that may reduce the service life of the power module, as well as it may be harmful to the application.

Therefore!

It is recommended not to set parameter 200 for different values in the 2 setups. If that should be necessary the user must make sure that setup changes are only made with stopped motor.

201 Min. output frequency (MIN OUTPUT FREQ)

Value:

0.0 HZ - f_{MAX} (parameter 202) [0 -]

☆ 0.0 HZ [0]

Function:

In this parameter, a minimum motor frequency limit can be selected that corresponds to the minimum frequency at which the motor is to run.

The minimum frequency can never be higher than the maximum frequency, f_{MAX} .

If *Both directions* has been selected in parameter 200, the minimum frequency is of no significance.

Description of choice:

A value from 0.0 Hz to the max. frequency selected in parameter 202 (f_{MAX}) can be chosen.

202 Max. output frequency (MAX OUTPUT FREQ)

Value:

f_{MIN} (parameter 201) - f_{RANGE} (132 Hz, par. 200)

☆ f_{RANGE}

Function:

In this parameter, a maximum motor frequency can be selected that corresponds to the highest frequency at which the motor is to run.

See also parameter 205.

Description of choice:

A value from f_{MIN} to 132 Hz can be selected.

203 Reference/feedback range (REF/FEEDB. RANGE)

Value:

☆ Min - Max (MIN - MAX) [0]

- Max - + Max (-MAX+MAX) [1]

Function:

This parameter decides whether the reference signal is to be positive or can be both positive and negative.



NB!

Analogue input (reference/feedback) can only be positive.

Choose *Min - Max* [0] if *Process, closed loop mode* has been selected in parameter 100.

Description of choice:

Choose the desired range.

204 Minimum reference (MIN. REFERENCE)

Value:

-100,000.000 - Ref_{MAX} (par. 205) [-100000000 -]

★ 0.000 [0]

Depends on parameter 100.

Function:

The *Minimum reference* gives the minimum setting that can be assumed by the sum of all references.

Minimum reference is only active if *Min - Max* [0] has been set in parameter 203; however, it is always active in *Process, closed loop mode* (parameter 100).

Description of choice:

Is only active when parameter 203 has been set to *Min - Max* [0].

Set the desired value.

205 Maximum reference (MAX. REFERENCE)

Value:

Ref_{MIN} (parameter 204)-100,000,000 [-100000000]

★ 50.000 HZ [50000]

Function:

The *Maximum reference* gives the highest value that can be assumed by the sum of all references. If parameter 100 has been selected to open loop the max. setting is 132 Hz.

If closed loop has been selected the maximum reference cannot be set higher than the maximum feedback (parameter 415).

Description of choice:

Set the desired value.

207 Ramp-up time 1 (RAMP UP TIME 1)

Value:

0.15 - 3600.00 sec. [5 -360000]

3.00 sec. [300]

Function:

The ramp-up time is the acceleration time from 0 Hz to the rated motor frequency $f_{M,N}$ (parameter 104). This presupposes that the current limit is not reached (to be set in parameter 221).

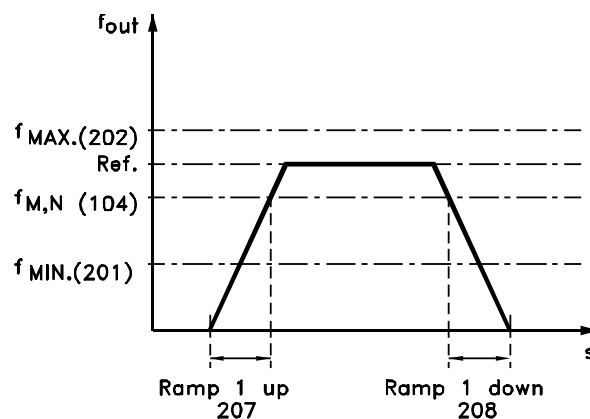

175NA007.11

Description of choice:

Program the desired ramp-up time.

208 Ramp-down time 1 (RAMP DOWN TIME 1)

Value:

0.15 - 3600.00 sec. [5 - 360000]

★ 3.00 sec. [300]

Function:

The ramp-down time is the deceleration time from the rated motor frequency $f_{M,N}$ (parameter 104) to 0 Hz provided there is no over-voltage in the inverter because of regenerative operation of the motor, and the current limit is not reached (to be set in parameter 221).

Description of choice:

Program the desired ramp-down time.

209 Ramp-up time 2 (RAMP UP TIME 2)

Value:

0.15 - 3600.00 sec. [5 - 360000]

★ 3.00 sec. [300]

Function:

The ramp-up time is the acceleration time from 0 Hz to the rated motor frequency $f_{M,N}$ (parameter 104). This presupposes that the current limit is not reached (to be set in parameter 221).

Description of choice:

Program the desired ramp-up time.

Shift from ramp 1 to ramp 2 by activating ramp 2 via a digital input.

210 Ramp-down time 2 (RAMP DOWN TIME 2)

Value:

0.15 - 3600.00 sec. [5 - 360000]

★ 3.00 sec. [300]

Function:

The ramp-down time is the deceleration time from the rated motor frequency $f_{M,N}$ (parameter 104) to 0 Hz provided there is no over-voltage in the inverter because of regenerative operation of the motor, and the current limit is not reached (to be set in parameter 221).

Description of choice:

Program the desired ramp-down time.

Shift from ramp 1 to ramp 2 by activating ramp 2 via a digital input

211 Jog ramp time (JOG RAMP TIME)

Value:

0.15 - 3600.00 sec. [5 - 360000]

★ 3.00 sec. [300]

Function:

The jog ramp time is the acceleration/deceleration time from 0 Hz to the rated motor frequency $f_{M,N}$ (parameter 104), provided there is no over-voltage in the inverter because of regenerative operation of the mo-

tor, and the current limit is not reached (to be set in parameter 221).

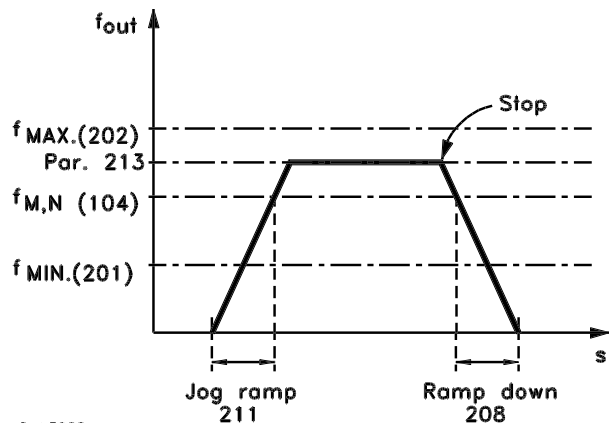

The jog ramp time starts if a jog signal is given via the digital inputs or the serial communication port.

Description of choice:

Set the desired ramp time.

212 Quick stop ramp-down time (Q STOP RAMP TIME)

Value:

0.15 - 3600.00 sec. [5 - 360000]

★ 3.00 sec. [300]

Function:

The ramp-down time is the deceleration time from the rated motor frequency to 0 Hz, provided there is no over-voltage in the inverter because of regenerative operation of the motor, and the current limit is not reached (to be set in parameter 221).

Quick-stop is activated by means of a signal on one of the digital input terminals (2-5), or via the serial communication port.

Description of choice:

Program the desired ramp-down time.

213 Jog frequency (JOG FREQUENCY)

Value:

0.0 HZ - parameter 202 [0 -]

★ 10.0 HZ [100]

Function:

The jog frequency f_{JOG} is the fixed output frequency at which the FC motor is running when the jog function is activated.

Description of choice:

Set the desired frequency.

214 Reference function (REF FUNCTION)

Value:

- ★ Sum (SUM) [0]
- External/preset (EXTERNAL/PRESET) [2]

Function:

It is possible to define how the preset references are to be added to the other references. For this purpose, *Sum* is used. It is also possible - by using the *External/preset* function - to select whether a shift between external references and preset references is desired.

Description of choice:

If *Sum* [0] is selected, one of the adjusted preset references (parameters 215-216) is added as a percentage of the maximum possible reference.

If *External/preset* [2] is selected, it is possible to shift between external references or preset references via terminal 2, 3, 4, or 5 (parameter 332, 333, 334, or 335). Preset references will be a percentage value of the reference range.

External reference is the sum of the analogue references, pulses and bus references.



NB!

If *Sum* is selected, one of the preset references will always be active. If the preset references are to be without influence, they should be set to 0 % (as in the factory setting).

215 Preset reference 1 (PRESET REF. 1)

216 Preset reference 2 (PRESET REF. 2)

Value:

-100.00 % - +100.00 % [-10000 - +10000]

% of the reference range/external reference

0.00%

[0]

Function:

Two different preset references can be programmed in parameters 215-216.

The preset reference is stated as a percentage of the value Ref_{MAX} or as a percentage of the other external references, depending on the choice made in parameter 214. If a $Ref_{MIN} \neq 0$ has been programmed, the preset reference as a percentage will be calculated on the basis of the difference between Ref_{MAX} and Ref_{MIN} , following the value is added to Ref_{MIN} .

Description of choice:

Set the fixed reference(s) that is/are to be the options.

To use the fixed references, it is necessary to have selected Preset ref. enable on terminal 2, 3, 4, or 5 (parameters 332 - 335).

Choices between fixed references can be made by activating terminal 2, 3, 4, or 5 - see the table below.

Terminals 2/3/4/5

Preset reference

| | |
|--------------------|---|
| Preset reference 1 | 0 |
| Preset reference 2 | 1 |



NB!

The parameter 215-216 setting automatically will be the setting of parameter 241-242 as well. Parameter 241-247 can be used for up to 7 preset references.

219 Catch up/slow down value (CATCH UP/SLW DWN)

Value:

0.00 - 100.00 % [0 - 10000]

- ★ 0.00 % [0]

Function:

This parameter enables the entry of a percentage value (relative) which will either be added to or deducted from the actual reference.

Description of choice:

If *Catch up* has been selected via one of the terminals 2, 3, 4, or 5 (parameters 332 - 335), the percentage (relative) value selected in parameter 219 will be added to the total reference.

If Slow down has been selected via one of the terminals 2, 3, 4, or 5 (parameters 332 - 335), the percentage (relative) value selected in parameter 219 will be deducted from the total reference.

221 Current limit for motor mode (CURRENT LIMIT)

Value:

Min. limit (XX.X) - max. limit (XXX.X)

in % of I_{RATED} [XXX - XXXX]

★ Max. limit (XXX.X) [XXXX]

I_{RATED} = rated motor current

Min. limit = magnetising current in % of I_{RATED}

Max. limit = unit dependent limit in % of I_{RATED}

Function:

This function is relevant for all application configurations; speed and process regulation. This is where to set the current limit for motor operation.

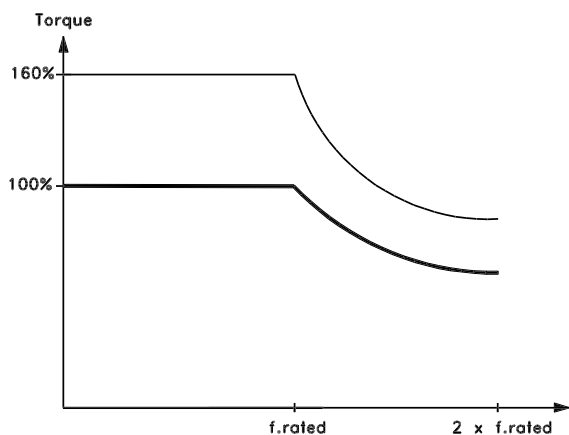

Description of choice:

Set the desired % of current.



NB!

The setting is limited to 160%, but for motors with 2 poles (0.55 + 1.1 kW), the setting is limited to 120% which corresponds to 160% torque, setting 73% corresponds to 100% torque.

229 Frequency bypass, bandwidth (FREQ BYPASS B.W.)

Value:

0 (OFF) - 100% [0-100]

0 (OFF) % [0]

Function:

Some SYSTEMs call for some output frequencies to be avoided because of resonance problems in the SYSTEM.

In parameters 230-231 these output frequencies can be programmed for bypassing (Frequency bypass). In this parameter (229), a bandwidth can be defined on either side of these frequency bypasses.

Description of choice:

The bypass band is the bypass frequency +/- half the set bandwidth.

A percentage of the setting in parameters 230-231 is selected.

230 Frequency bypass 1 (FREQ. BYPASS 1)

231 Frequency bypass 2 (FREQ. BYPASS 2)

Value:

0.0 - 132 Hz (parameter 200) [0 -]

★ 0.0 Hz [0]

Function:

Some SYSTEMs call for some output frequencies to be avoided because of resonance problems in the SYSTEM.

Description of choice:

Enter the frequencies to be avoided.

See also parameter 229.

| | |
|-----|--------------------|
| 241 | Reference preset 1 |
| | (REF PRESET 1) |
| 242 | Reference preset 2 |
| | (REF PRESET 2) |
| 243 | Reference preset 3 |
| | (REF PRESET 3) |
| 244 | Reference preset 4 |
| | (REF PRESET 4) |
| 245 | Reference preset 5 |
| | (REF PRESET 5) |
| 246 | Reference preset 6 |
| | (REF PRESET 6) |
| 247 | Reference preset 7 |
| | (REF PRESET 7) |

Value:

-100.00 % - +100.00 % [-10000 - +10000]

% of the reference range/external reference

★ 0.00% [0]

Function:

Seven different reference presets can be programmed in parameters 241 - 247 *reference preset*. The reference preset is stated as a percentage of the value Ref_{MAX} or as a percentage of the other external references, depending on the choice made in parameter 214. If a Ref_{MIN} • 0 has been programmed, the reference preset as a percentage will be calculated on the basis of the difference between Ref_{MAX} and Ref_{MIN} following the value is added to Ref_{MIN}.

The choice between reference presets can be made via the digital inputs or via serial communication.

Description of choice:

Set the fixed reference(s) that is/are to be the option.

See P332, P333, P334 and P335 Description of choice, where the description of the digital input set up is given.

317 Time out (LIVE ZERO TIME OUT)

Value:

- 1 - 99 sec. [1 - 99]
- ★ 10 sec. [10]

Function:

If the value of the reference signal connected to the input, terminal 1, falls below 50% of the setting in parameter 336 for a period longer than the time set in parameter 317, the function selected in parameter 318 will be activated.

Description of choice:

Set the desired time.

318 Function after time out (LIVE ZERO FUNCT.)

Value:

- ★ Off (OFF) [0]
- Stop and trip (STOP AND TRIP) [5]

Function:

This parameter allows a choice of the function to be activated if the value of the reference signal connected to the input, terminal 1, falls below 50% of the setting in parameter 336 for a period longer than the time set in parameter 317.

If a time-out function (parameter 318) occurs at the same time as a bus time-out function (parameter 514), the time-out function (parameter 318) will be activated.

323 Terminal X102, relay function (RELAY FUNC.)

Settings:

| | | |
|----------------------------------|------------------------|------|
| ★ No function | (NO OPERATION) | [0] |
| Ready signal | (UNIT READY) | [1] |
| Enable, no warning | (ENABLE/NO WARNING) | [2] |
| Running | (MOTOR RUNNING) | [3] |
| Running, no warning | (RUNNING NO WARNING) | [4] |
| Running on reference, no warning | (RUNNING ON REFERENCE) | [5] |
| Fault | (FAULT) | [6] |
| Fault or warning | (FAULT OR WARNING) | [7] |
| Current limit | (CURRENT LIMIT) | [8] |
| Thermal warning | (THERMAL WARNING) | [9] |
| Reversing | (REVERSE) | [10] |
| Control word bit 11 | (CONTROL WORD BIT 11) | [11] |
| Control word bit 12 | (CONTROL WORD BIT 12) | [12] |
| Mechanical brake | (MECHANICAL BRAKE) | [20] |

The relay output can be used to give the present status or a warning.

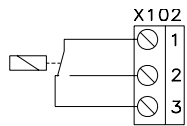

175NA122.10

Relay
1 - 3 break, 1 - 2 make
Max. 250 V AC, 5Amp.

Description of choice:

Unit Ready signal, the FC motor is ready for use.

Enable/no warning, the FC motor is ready for use; no start or stop command has been given (start/ disable). No warning.

Motor Running, the output frequency is higher than 0.1 Hz. A start command has been given.

Running no warning, the output frequency is higher than 0.1 Hz. A start command has been given. No warning.

Running on reference, no warning, speed according to reference. No warning.

Fault, output is activated by alarm.

Fault or warning, the output is activated by alarm or warning.

Current limit, the current limit in parameter 221 has been exceeded.

Thermal warning, above the temperature limit in the frequency converter.

Reverse. Logic '1' = relay activated, 24 V DC on the output when the direction of rotation of the motor is clockwise. Logic '0' = relay not activated, no signal on

★ = factory setting, () = display text, [] = value for use in communication via serial communication port

the output, when the direction of rotation of the motor is counter-clockwise.

Control word bit 11, if bit 11 = "1" in the control word (both Fieldbus Profile and FC Profile) the relay will be activated.

Control word bit 12, if bit 12 = "1" in the control word (both Fieldbus Profile and FC Profile) the relay will be activated.

Mechanical brake, enables control of an optional external mechanical brake (see also parameter 138 and 139).

327 Pulse reference/feedback, max. frequency (PULSE REF/FB MAX)

Value:

100 - 70000 Hz [100 - 70000]

★ 5000 HZ [5000]

Function:

In this parameter, the signal value is set that corresponds to the maximum reference/feedback value set in parameter 205/415.

Description of choice:

Set the desired pulse frequency.



NB!

Frequency limit:
Open collector 24 V: 8 kHz
Push pull 24 V: 70 kHz

331 Terminal 1, analogue input current (AI [mA] 1 FUNCT)

Value:

| | |
|-------------------------------|-----|
| ★ No operation (NO OPERATION) | [0] |
| Reference (REFERENCE) | [1] |
| Feedback (FEEDBACK) | [2] |

Function:

This parameter allows a choice between the different functions available for the input, terminal 1.

Scaling of the input signal is effected in parameters 336 and 337.

Description of choice:

No operation. Is selected if the FC motor is not to react to signals connected to the terminal.

Reference. Is selected to enable change of reference by means of an analogue reference signal.

If other inputs are connected, these are added up, taking account of their signs.

Feedback. Is selected if closed loop regulation with an analogue signal is used.



NB!

If *Reference* or *Feedback* has been selected on more than one terminal, these signals will be added.

332 Terminal 2, analogue/digital input (DIGITAL INPUT 2)

333 Terminal 3, digital input (DIGITAL INPUT 3)

334 Terminal 4, digital input (DIGITAL INPUT 4)

335 Terminal 5, digital input (DIGITAL INPUT 5)

| Parameter | | 332 | 333 | 334 | 335 |
|----------------------------------|------------------------|------|--------|-------|--------|
| Digital input on terminal no. | | 2 | 3 | 4 | 5 |
| Settings: | | | | | |
| No function | (NO OPERATION) | [0] | [0] | [0] | [0] |
| Reset | (RESET) | [1] | ★ [1] | [1] | [1] |
| Coasting stop, inverse | (MOTOR COAST INVERSE) | [2] | [2] | [2] | [2] |
| Reset and coasting stop, inverse | (RESET & COAST INV.) | [3] | [3] | [3] | [3] |
| Quick-stop, inverse | (QUICK STOP INVERSE) | [4] | [4] | [4] | [4] |
| DC-braking, inverse | (DC-BRAKE INVERSE) | [5] | [5] | [5] | [5] |
| Stop inverse | (STOP INVERSE) | [6] | [6] | [6] | [6] |
| Start | (START) | [7] | [7] | ★ [7] | [7] |
| Latched start | (LATCHED START) | [8] | [8] | [8] | [8] |
| Reversing | (REVERSING) | [9] | [9] | [9] | [9] |
| Start reversing | (START REVERSING) | [10] | [10] | [10] | [10] |
| Start clockwise, on | (ENABLE FORWARD) | [11] | [11] | [11] | [11] |
| Start counter-clockwise, on | (ENABLE REVERSE) | [12] | [12] | [12] | [12] |
| Jog | (JOGGING) | [13] | [13] | [13] | ★ [13] |
| Freeze reference | (FREEZE REFERENCE) | [14] | [14] | [14] | [14] |
| Freeze output | (FREEZE OUTPUT) | [15] | [15] | [15] | [15] |
| Speed up | (SPEED UP) | [16] | [16] | [16] | [16] |
| Speed down | (SPEED DOWN) | [17] | [17] | [17] | [17] |
| Selection of Setup | (SETUP SELECT) | [18] | [18] | [18] | [18] |
| Catch-up | (CATCH UP) | [19] | [19] | [19] | [19] |
| Slow-down | (SLOW DOWN) | [20] | [20] | [20] | [20] |
| Preset reference | (PRESET REF.) | [21] | [21] | [21] | [21] |
| Preset reference, on | (PRESET REF. ON) | [22] | [22] | [22] | [22] |
| Precise stop, inverse | (PRECISE STOP) | | | [23] | |
| Pulse reference | (PULSE REFERENCE) | | [24] | | |
| Pulse feedback | (PULSE FEEDBACK) | | [25] | | |
| Analogue reference | (REFERENCE) | | ★ [30] | | |
| Analogue feedback | (FEEDBACK) | [31] | | | |
| Reset and start | (RESET AND START) | [32] | [32] | [32] | [32] |
| Freeze reference and start | (FREEZE REF AND START) | [33] | [33] | [33] | [33] |
| Ramp 2 | (RAMP 2) | [34] | [34] | [34] | [34] |
| Start-ref bit 1 | (START-REF BIT 1) | [35] | [35] | [35] | [35] |
| Start-ref bit 2 | (START-REF BIT 2) | [36] | [36] | [36] | [36] |
| Start-ref bit 3 | (START-REF BIT 3) | [37] | [37] | [37] | [37] |

Function:

In parameters 332-335 it is possible to choose between the different possible functions related to the inputs on terminals 2-5. The function options are shown in the table below.

Description of choice:

No function is selected if the FC motor is not to react to signals transmitted to the terminal.

Reset zeroes the FC motor after an alarm; however, not all alarms can be reset without disconnecting from mains.

Coasting stop, inverse is used for making the FC motor run freely to stop. Logic '0' leads to coasting stop.

Reset and coasting stop, inverse, is used for activating coasting stop at the same time as reset.

Logic '0' leads to coasting stop and reset.

Quick stop, inverse is used for stopping the motor in accordance with the quick-stop ramp (set in parameter 212).

Logic '0' leads to a quick-stop.

DC braking, inverse is used for stopping the motor by energizing it with a DC voltage for a given time, see parameters 126-132.

★ = factory setting, () = display text, [] = value for use in communication via serial communication port

Please note that this function is only active if the settings of parameters 126-132 is different from 0. Logic '0' leads to DC braking.

Stop inverse is activated by interrupting the voltage to the terminal. This means that if the terminal has no voltage, the motor cannot run. The stop will be effected in accordance with the selected ramp (parameters 207/208).



None of the above-mentioned stop commands are to be used as disconnection switch in connection with repairs. Cut mains instead.

Start, is selected if a start/stop command is desired. Logic '1' = start, logic '0' = stop (stand-by).

Latched start - if a pulse is applied for min. 20 ms, the motor will start, provided no stop command. The motor stops if *Stop inverse* is activated briefly.

Reversing is used for changing the direction of rotation of the motor shaft. Logic "0" will not lead to reversing. Logic "1" will lead to reversing. The reversing signal only changes the direction of rotation; it does not activate the start function.

Should not be used with *Process, closed loop mode*.

Start reversing, is used for start/stop and for reversing with the same signal. No start signal is allowed at the same time. Acts as latch start reversing, provided latch start has been chosen for another terminal.

Should not be used with *Process, closed loop mode*.

Start clockwise is used if the motor shaft is only to be able to rotate clockwise when starting.

Should not be used with *Process, closed loop mode*.

Start counter-clockwise, on is used if the motor shaft is to be able to rotate counter-clockwise when started.

Should not be used with *Process, closed loop mode*.

Jog is used for overriding the output frequency to the jog frequency set in parameter 213. The ramp time can be set in parameter 211. Jog is not active if a stop command has been given (start-disable).

Jog overrides stand-by.

Freeze reference - freezes the actual reference. The frozen reference is now the point of enable/ condition for *Speed up* and *Speed down* to be used.

If speed up/down is used, the speed change always follows the normal ramp (parameters 207/208) in the range 0 - Ref_{MAX}.

Freeze output - freezes the actual motor frequency (Hz). The frozen motor frequency is now the point of enable/condition for *Speed up* and *Speed down* to be used.

Freeze output overrides start/stand-by, slip compensation and closed loop process control.

If speed up/down is used, the speed change always follows the normal ramp (parameters 207/208) in the range 0 - f_{M,N}.

Speed up and *Speed down* are selected if digital control of the up/down speed is desired (motor potentiometer). This function is only active if *Freeze reference* or *Freeze output* has been selected.

As long as there is a logic '1' on the terminal selected for speed up, the reference or the output frequency will increase.

As long as there is a logic '1' on the terminal selected for speed down, the reference or the output frequency will be reduced.

Pulses (logic '1' minimum high for 20 ms and a minimum pause of 20 ms) will lead to a change of speed of 0.1% (reference) or 0.1 Hz (output frequency).

Example:

| | Terminal 2-5 | Terminal 2-5 | Freeze ref./ Freeze output |
|-----------------|-----------------|-----------------|-------------------------------|
| No speed change | 0 | 0 | 1 |
| Speed down | 0 | 1 | 1 |
| Speed up | 1 | 0 | 1 |
| Speed down | 1 | 1 | 1 |

Selection of Setup, enables a choice of one of the two Setups; however, this presupposes that parameter 004 has been set to *Multi Setup*.

Catch-up/Slow-down is selected if the reference value is to be increased or reduced by a programmable percentage value set in parameter 219.

| | Slow-down | Catch-up |
|----------------------|-----------|----------|
| Unchanged speed | 0 | 0 |
| Reduced by %-value | 1 | 0 |
| Increased by %-value | 0 | 1 |
| Reduced by %-value | 1 | 1 |

Preset reference enables a choice of one of the two preset references, in accordance with the table in parameter 215 and 216. To be active, *Preset reference*, on has to be selected.

Preset reference is used for shifting between external reference and preset reference. It is assumed that *External/preset* [2] has been selected in parameter 214. Logic '0' = external references active; logic '1' = one of the two preset references is active.

Precise stop corrects the ramp-down time to obtain a high repetitive accuracy of the stopping point.

Pulse reference is selected if a pulse sequence (frequency) of 0 Hz is used, corresponding to Ref_{MIN}, parameter 204. The frequency is set in parameter 327, corresponding to Ref_{MAX}.

Pulse feedback is selected if a pulse sequence (frequency) is selected as a feedback signal. See also parameter 327.

Analogue reference is selected to enable change of reference by means of an analogue reference signal.

If other inputs are connected, these are added up, taking account of their signs.

Analogue feedback is selected if closed loop regulation with an analogue signal is used.

Reset and start is used for activating start at the same time as reset.

Freeze reference and start, both a START and a FREEZE REFERENCE command will be initiated. When using SPEED UP/SPEED DOWN both FREEZE REFERENCE and START must be activated. By implementing this feature a digital input can be spared.

Ramp 2, is selected if a shift between ramp 1 (parameters 207-208) and ramp 2 (parameters 209-210) is required. Logic "0" leads to ramp 1 and logic "1" leads to ramp 2.

Start-ref bit 1,2 and 3, makes it possible to select which REF RESET (1-7) is to be used. The REF PRESET (1-7) are set in parameters 241 to 247.

| Par. No | Fixed speed | START REF BIT |
|---------|-------------|---------------|
| - - - | | 321 |
| - - - | Stand by | 000 |
| 241 | REF RESET 1 | 001 |
| 242 | REF RESET 2 | 010 |
| 243 | REF RESET 3 | 011 |
| 244 | REF RESET 4 | 100 |
| 245 | REF RESET 5 | 101 |
| 246 | REF RESET 6 | 110 |
| 247 | REF RESET 7 | 111 |

If at least one of the 3 digital inputs is activated the FCM has start signal. The 7 possible input combinations will then decide which preset speed is to be used. If only 1 or 2 digital inputs are used respectively 1 or 3 speeds can be chosen after above shown principle. If 2 set-ups are used up to 14 preset speeds can be chosen by means of 4 digital inputs. The P241 and P242 settings will be mirrored into P215 and P216.

Ex.

Digital inputs 2,3 and 4: P332 [choice 35 selected], P333 [choice 36 selected] and P334 [choice 37 selected]

Input combination on the digital inputs 2,3 and 4: "010". This means REF PRESET 2 will be the preset speed. Scaling of the input signal is effected in parameters 338 and 339.



NB!

If *Reference* or *Feedback* has been selected on more than one terminal, these signals will be added with signs.

336 Terminal 1, min. scaling (AI 1 SCALE LOW)

Value:

0.0 - 20.0 mA [0 - 200]

★ 0.0 mA [0]

Function:

This parameter determines the value of the reference signal that is to correspond to the minimum reference value set in parameter 204.

If the *Time-out* function of parameter 317 is to be used, the setting must be > 2 mA.

Description of choice:

Set the desired current value.

337 Terminal 1, max. scaling (AI 1 SCALE HIGH)

Value:

0.0 - 20.0 mA [0 - 200]

★ 20.0 mA [200]

Function:

This parameter sets the value of the reference signal that is to correspond to the maximum reference value set in parameter 205.

Description of choice:

Set the desired current value.

338 Terminal 2, min. scaling (AI 2 SCALE LOW)

Value:

0.0 - 10.0 V [0 - 100]

★ = factory setting, () = display text, [] = value for use in communication via serial communication port

☆ 0.0 V

[0]

0.0 - 10.0 V 0.0 - 10.0 V

[0 - 100]

Function:

This parameter is used for setting the signal value that is to correspond to the minimum reference or the minimum feedback, parameter 204 *Minimum reference*, Ref_{MIN} / 414 *Minimum feedback*, FB_{MIN} .

Description of choice:

Set the required voltage value. For reasons of accuracy, compensation should be made for voltage loss in long signal cables. If the Time out function is to be used (parameter 317 *Time out* and 318 *Function after time out*), the value set must be higher than 1 Volt.

☆ 10.0 V

[100]

Function:

This parameter is used for setting the signal value that is to correspond to the maximum reference value or maximum feedback, parameter 205 *Maximum reference*, Ref_{MAX} / 415 *Maximum feedback*, FB_{MAX} .

Description of choice:

Set the required voltage value. For reasons of accuracy, compensation should be made for voltage losses in long signal cables.

339 Terminal 2, max. scaling
(AI 2 SCALE HIGH)
Value:
340 Terminal 9, output functions (OUTPUT FUNC.)

Settings:

| | | |
|---|------------------------|------|
| ☆ No function | (NO OPERATION) | [0] |
| Ready signal | (UNIT READY) | [1] |
| Enable, no warning | (ENABLE/NO WARNING) | [2] |
| Running | (MOTOR RUNNING) | [3] |
| Running, no warning | (RUNNING NO WARNING) | [4] |
| Running on reference, no warning | (RUNNING ON REFERENCE) | [5] |
| Fault | (FAULT) | [6] |
| Fault or warning | (FAULT OR WARNING) | [7] |
| Current limit | (CURRENT LIMIT) | [8] |
| Thermal warning | (THERMAL WARNING) | [9] |
| Reversing | (REVERSE) | [10] |
| Control word bit 11 | (CONTROL WORD BIT 11) | [11] |
| Actual frequency 0-20 mA | (0-FMAX = 0-20 mA) | [12] |
| Actual frequency 4-20 mA | (0-FMAX = 4-20 mA) | [13] |
| Reference _{MIN} - reference _{MAX} : 0-20 mA | (REF MIN-MAX =0-20 mA) | [14] |
| Reference _{MIN} - reference _{MAX} : 4-20 mA | (REF MIN-MAX =4-20 mA) | [15] |
| Feedback _{MIN} - feedback _{MAX} : 0-20 mA | (FB MIN-MAX =0-20 mA) | [16] |
| Feedback _{MIN} - feedback _{MAX} : 4-20 mA | (FB MIN-MAX =4-20 mA) | [17] |
| Actual current 0-20 mA | (0-IMAX = 0-20 mA) | [18] |
| Actual current 4-20 mA | (0-IMAX = 4-20 mA) | [19] |
| Mechanical brake | (MECHANICAL BRAKE) | [20] |
| Sleep mode | (SLEEP MODE) | [21] |
| Torque 0-20 mA | (0-TMAX = 0-20 mA) | [22] |
| Torque 4-20 mA | (0-TMAX = 4-20 mA) | [23] |

Function:

This output can act both as a digital and an analogue output. If used as a digital output (data value [0]-[23]), a 24 V DC signal is transmitted; if used as an analogue

output either a 0-20 mA signal, or a 4-20 mA signal output.

Description of choice:

Unit Ready signal, the FC motor is ready for use.

Enable/no warning, the FC motor is ready for use; no start or stop command has been given (start/ disable). No warning.

$0-T_{MAX}$ • 4-20 mA and

Motor Running, the output frequency is higher than 0.1 Hz or a start command has been given.

Running no warning, the output frequency is higher than 0.1 Hz. A start command has been given. No warning.

Running on reference, no warning, speed according to reference. No warning.

Fault, output is activated by alarm.

Fault or warning, the output is activated by alarm or warning.

Current limit, the current limit in parameter 221 has been exceeded.

Thermal warning, above the temperature limit in the frequency converter.

Reverse. Logic '1' = relay activated, 24 V DC on the output when the direction of rotation of the motor is clockwise. Logic '0' = relay not activated, no signal on the output, when the direction of rotation of the motor is counter-clockwise.

Control word bit 11, if bit 11 = "1" in the control word (both Fieldbus Profile and FC Profile) the digital output will be activated.

$0-f_{MAX}$ (parameter 202) • 0-20 mA and

$0-f_{MAX}$ (parameter 202) • 4-20 mA

$Reference_{MIN}$ - $Reference_{MAX}$: 0-20 mA and

$Reference_{MIN}$ - $Reference_{MAX}$: 4-20 mA

$Feedback_{LOW}$ - $Feedback_{HIGH}$: 0-20 mA and

$Feedback_{LOW}$ - $Feedback_{HIGH}$: 4-20 mA

$0-I_{VLT, MAX}$ • 0-20 mA and

$0-I_{VLT, MAX}$ • 4-20 mA

Mechanical brake, enables control of an optional external mechanical brake (see also parameter 138 and 139).



NB!

Analog signal

4 mA: Closed brake

20 mA: Open brake

0 mA: Fault

Not suited for switching a relay

Sleep mode, active when the unit is in sleep mode. See section *Sleep mode*.

$0-T_{MAX}$ • 0-20 mA and

400 Brake functions (BRAKE FUNCTIONS)

Value:

| | |
|---------------------|-----|
| OFF (OFF) | [0] |
| AC brake (AC BRAKE) | [4] |

Function:

AC brake [4] can be selected to improve braking. With the new AC brake function it is possible to control the time of increased motor losses, still protecting the motor thermally. This function will yield a braking torque between 80 and 20 % in the speed range up to base speed (50 Hz). Above base speed the extra braking will gradually disappear.

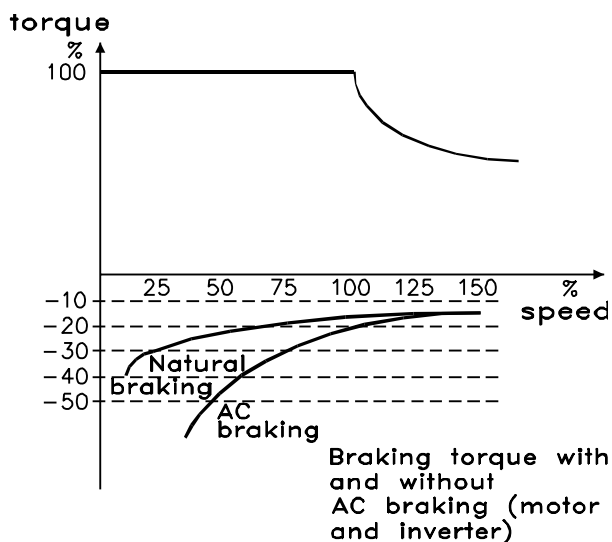

175NA106.10

Description of choice:

Select *AC brake* [4] if short-term generated loads occur.

■ Sleep mode

Sleep mode makes it possible to stop the motor when it is running at low speed, similar to a no load situation. If consumption in the system goes back up, the frequency converter will start the motor and supply the power required.



NB!

Energy can be saved with this function, since the motor is only in operation when the system needs it.

Sleep mode is not active if *Local reference* or *Jog* has been selected

The function is active in both *Open loop* and *Closed loop*.

In parameter 403 *Sleep mode timer*, the Sleep mode is activated. In parameter 403 *Sleep mode timer*, a timer is set that determines how long the output frequency can be lower than the frequency set in parameter 404 *Sleep frequency*. When the timer runs out, the frequency converter will ramp down the motor to stop via parameter 208 *Ramp-down time*. If the output frequency rises above the frequency set in parameter 404 *Sleep frequency*, the timer is reset.

While the frequency converter has stopped the motor in sleep mode, a theoretical output frequency is calculated on the basis of the reference signal. When the theoretical output frequency rises above the frequency in parameter 407 *Wake up frequency*, the frequency converter will restart the motor and the output frequency will ramp up to the reference.

In systems with constant pressure regulation, it is advantageous to provide extra pressure to the system before the frequency converter stops the motor. This extends the time during which the frequency converter has stopped the motor and helps to avoid frequent

starting and stopping of the motor, e.g. in the case of system leaks.

If 25% more pressure is required before the frequency converter stops the motor, parameter 406 *Boost setpoint* is set to 125%.

Parameter 406 *Boost setpoint* is only active in *Closed loop*.



NB!

In highly dynamic pumping processes, it is recommended to switch off the *Flying Start* function (parameter 445).

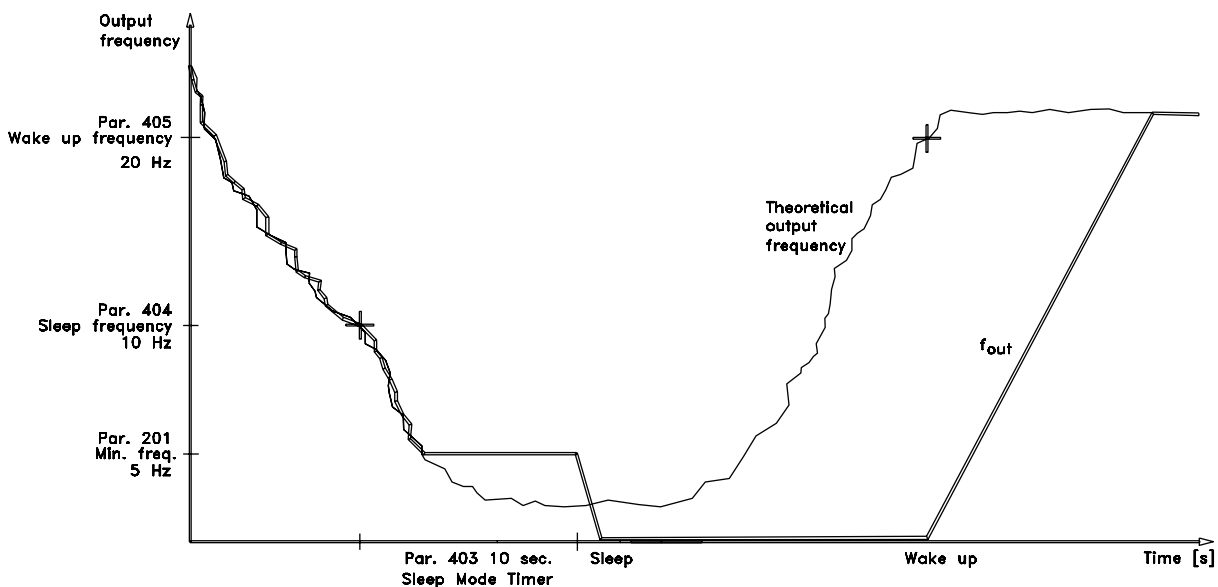

1756A348.14

Programming

★ = factory setting, () = display text, [] = value for use in communication via serial communication port

403 Sleep mode timer (SLEEP MODE TIMER)

Value:

0 - 300 sec. (301 sec. = OFF) ★ OFF

Function:

This parameter enables the frequency converter to stop the motor if the load on the motor is minimal. The timer in parameter 403 *Sleep mode timer* starts when the output frequency drops below the frequency set in parameter 404 *Sleep frequency*.

When the time set in the timer has expired, the frequency converter will turn off the motor.

The frequency converter will restart the motor, when the theoretical output frequency exceeds the frequency in parameter 407 *Wake up frequency*.

Description of choice:

Select OFF if this function is not wanted. Set the threshold value that is to activate Sleep mode after the output frequency has fallen below parameter 404 *Sleep frequency*.

404 Sleep frequency (SLEEP FREQUENCY)

Value:

000,0 - par. 407 *Wake up frequency* ★ 0,0 Hz

Function:

When the output frequency falls below the preset value, the timer will start the time count set in parameter 403 *Sleep mode*. The present output frequency will follow the theoretical output frequency until f_{MIN} is reached.

Description of choice:

Set the required frequency.

405 Reset function (RESET MODE)

Value:

- ★ Manual reset (manual RESET) [0]
- Automatic reset x 1 (AUTOMATIC X 1) [1]
- Automatic reset x 2 (AUTOMATIC X 2) [2]
- Automatic reset x 3 (AUTOMATIC X 3) [3]
- Automatic reset x 4 (AUTOMATIC X 4) [4]
- Automatic reset x 5 (AUTOMATIC X 5) [5]
- Automatic reset x 6 (AUTOMATIC X 6) [6]
- Automatic reset x 7 (AUTOMATIC X 7) [7]

- Automatic reset x 8 (AUTOMATIC X 8) [8]
- Automatic reset x 9 (AUTOMATIC X 9) [9]
- Automatic reset x 10 (AUTOMATIC X 10) [10]
- Reset at power-up (RESET AT POWER UP) [11]

Function:

This parameter makes it possible to select the reset function desired after tripping.

After reset, the FC motor can be restarted after 1.5 sec.

Description of choice:

If *Manual reset* [0] is selected, reset must be effected via the digital inputs.

If the FC motor is to carry out an automatic reset (max. 1-10 times within 10 minutes) after tripping, select data value [1]-[10].



Warning: The motor may start without warning up to 10 x 5 sec. after trip.

406 Boost setpoint (BOOST SETPOINT)

Value:

1 - 200 % ★ 100 % of setpoint

Function:

This function can only be used if *Closed loop* has been selected in parameter 100.

In SYSTEMs with constant pressure regulation, it is advantageous to increase the pressure in the SYSTEM before the frequency converter stops the motor. This extends the time during which the frequency converter stops the motor and helps to avoid frequent starting and stopping of the motor, e.g. in the case of leaks in the water supply SYSTEM.

Use *Boost Time-Out*, par. 472, to set the boost time-out. If the boost set-point cannot be reached within the specified time, the frequency converter will continue in normal operation (Not entering sleep mode).

Description of choice:

Set the required *Boost setpoint* as a percentage of the resulting reference under normal operation. 100% corresponds to the reference without boost (supplement).

407 Wake up frequency (WAKEUP FREQUENCY)

Value:

Par 404 *Sleep frequency* - par. 202 f_{MAX} ★ 50 Hz

Function:

When the theoretical output frequency exceeds the preset value, the frequency converter restarts the motor.

Description of choice:

Set the required frequency.

411 Switching frequency (SWITCH FREQ.)

Value:

1.5 -14.0 kHz [1500 - 14000]

★ Unit dependent

Function:

The setting determines the switching frequency of the inverter. If the switching frequency is changed, this may help to minimise possible acoustic noise from the motor.

Description of choice:

When the motor is running, the switching frequency is adjusted in parameter 411 until the frequency has been obtained at which the motor is as low-noise as possible.

See also parameter 446 - switching pattern. See derating in chapter 10.



NB!

Switching frequencies higher than 4 kHz may cause thermal trip depending on ambient temperature.

412 Variable switching frequency (VAR CARRIER FREQ.)

Value:

Not possible (DISABLE) [0]

Variable switching freq. (VAR. CARRIER FREQ.) [1]

★ Temperature dep. sw. freq. (TEMP. DEP. FREQ.) [2]

Function:

This function makes it possible to change the switching frequency depending on the load. However, the maximum switching frequency is determined by the value set in parameter 411.

Description of choice:

Select *Not possible* [0] if a permanent switching frequency is desired. Set the switching frequency in parameter 411.

If *Variable switching frequency* [1] is selected the switching frequency will decline at an increasing output frequency. This is used in applications with square torque characteristics (centrifugal pumps and fans) in which the load declines depending on the output frequency.

If *Temperature dependent switching frequency* [2] is selected, the switching frequency will decline at an increasing inverter temperature, see the drawing below.

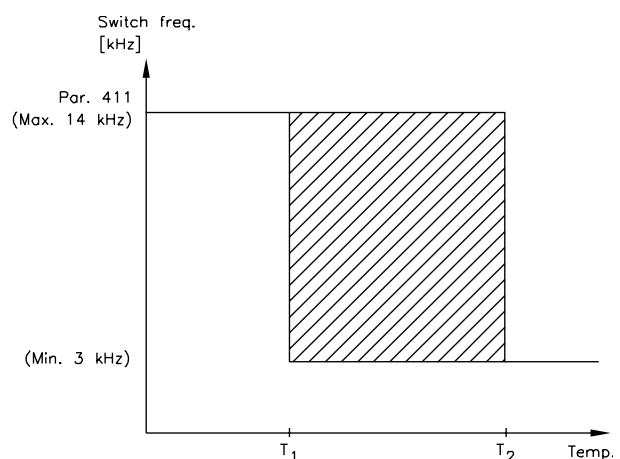

175NA020.13

413 Overmodulation function (OVERMODULATION)

Value:

Off (OFF) [0]

★ On (ON) [1]

Function:

This parameter allows connection of the overmodulation function for the output voltage.

Description of choice:

Off means that there is no overmodulation of the output voltage, which means that torque ripple on the motor shaft is avoided. This can be a good feature, e.g. on grinding machines.

On means that an output voltage can be obtained which is greater than the mains voltage (up to 5%).

| | |
|---|-------------------------|
| 414 | Minimum feedback |
| | (MIN. FEEDBACK) |
| Value: | |
| -100,000,000 - FB _{HIGH} (par. 415) [-100000000 -] | |
| ★ 0.000 | [0] |

Function:
Parameters 414 and 415 are used to scale the feedback range to physical values used by the user. The setting will also be the bounds of the reference (parameters 204 and 205).

Used together with *Process, closed loop mode* (parameter 100).

Description of choice:
Is only active when parameter 203 has been set to *Min-Max* [0].

| | |
|--|-------------------------|
| 415 | Maximum feedback |
| | (MAX. FEEDBACK) |
| Value: | |
| (par. 414) FB _{LOW} - 100,000,000 [- 100000000] | |
| ★ 1.500.000 | [1500000] |

Function:
See description of parameter 414.

| | |
|---------------|--------------------------------|
| 416 | Reference/feedback unit |
| | (REF/FEEDB. UNIT) |
| Value: | |
| NO UNIT | [0] |
| ★ % | [1] |
| PPM | [2] |
| RPM | [3] |
| bar | [4] |
| CYCLE/min | [5] |
| PULSE/s | [6] |
| UNITS/s | [7] |
| UNITS/min | [8] |
| UNITS/h | [9] |
| °C | [10] |
| Pa | [11] |

| | |
|----------------------|------|
| l/s | [12] |
| m ³ /s | [13] |
| l/min | [14] |
| m ³ /min | [15] |
| l/h | [16] |
| m ³ /h | [17] |
| kg/s | [18] |
| kg/min | [19] |
| kg/h | [20] |
| t/min | [21] |
| t/h | [22] |
| m | [23] |
| Nm | [24] |
| m/s | [25] |
| m/min | [26] |
| °F | [27] |
| in wg | [28] |
| gal/s | [29] |
| ft ³ /s | [30] |
| gal/min | [31] |
| ft ³ /min | [32] |
| gal/h | [33] |
| ft ³ /h | [34] |
| lb/s | [35] |
| lb/min | [36] |
| lb/h | [37] |
| lb ft | [38] |
| ft/s | [39] |
| ft/min | [40] |

Function:
Choose among different units to be shown on the display.

This unit is also used directly in *Process regulation, closed loop* as a unit for *Minimum/Maximum reference* (parameters 204/205) and *Minimum/ Maximum feedback* (parameters 414/415).

The possibility of choosing a unit in parameter 416 will depend on the choices made in the following parameters:

- Par. 002 *Local/remote control*.
- Par. 013 *Local control/config. as par. 100*.
- Par. 100 *Configuration*.

Select parameter 002 as Remote control

★ = factory setting, () = display text, [] = value for use in communication via serial communication port

If parameter 100 is selected as *Speed regulation, open loop*, the unit selected in parameter 416 can be used in displays (par. 009-12 *Feedback [unit]*) of process parameters.

Note: The reference can only be shown in Hz (*Speed regulation, open loop*).

If parameter 100 is selected as *Process regulation, closed loop*, the unit selected in parameter 416 will be used when displaying both reference (par. 009- 12: *Reference [unit]*) and feedback (par. 009-12: *Feedback [unit]*).

Select parameter 002 as Local control

If parameter 013 is chosen as *LCP control and open loop* or *LCP digital control and open loop*, the reference will be given in Hz, regardless of the choice made in parameter 416. If parameter 013 is chosen as *LCP control/as par. 100* or *LCP digital control/as par. 100*, the unit will be as described above under parameter 002, *Remote-control*.



NB!

The above applies to display of *Reference [unit]* and *Feedback [unit]*. If *Reference [%]* or *Feedback [%]* is selected, the value displayed will be in the form of a percentage of the selected range.

Description of choice:

Select the desired unit for the reference/feedback signal.

■ FCM 300 Regulator

Process regulation

The PID regulator maintains a constant process mode (pressure, temperature, flow, etc.) and adjusts the motor speed on the basis of the reference/setpoint and feedback signal.

A transmitter provides the PID regulator with a feedback signal from the process as an expression of the process's actual mode. The feedback signal varies as the process load varies.

This means that there is a variance between the reference/setpoint and the actual process mode. This variance is compensated by the PID regulator by means of the output frequency being regulated up or down in relation to the variance between the reference/setpoint and the feedback signal.

The integrated PID regulator in the frequency converter has been optimised for use in process applications. This means that there are a number of special functions available in the frequency converter.

Previously it was necessary to obtain a SYSTEM to handle these special functions by installing extra I/O modules and programming the SYSTEM. With the frequency converter the need to install extra modules can be avoided. The parameters that are specific to the Process Regulator are parameter 437 to parameter 444.

■ PID functions

Unit of reference/feedback

When *Process regulation, closed loop* is selected in parameter 100 *Configuration* the unit is defined in parameter 416 *Reference/feedback unit*:

Feedback

A feedback range must be preset for the regulator. At the same time this feedback range limits the potential reference range so that if the sum of all references lies outside the feedback range, the reference will be limited to lie within the feedback range.

The feedback signal must be connected to a terminal on the frequency converter. If feedback is selected on two terminals simultaneously, the two signals will be added together.

Use the overview below to determine which terminal is to be used and which parameters are to be programmed.

| Feedback type | Terminal | Parameters |
|---------------|----------|---------------|
| Pulse | 3 | 333, 327 |
| Voltage | 2 | 332, 338, 339 |
| Current | 1 | 331, 336, 337 |

A correction can be made for loss of voltage in long signal cables when a transmitter with a voltage output is used. This is done in parameters 338/339 *Min./Max scaling*.

Parameters 414/415 *Minimum/Maximum feedback* must also be preset to a value in the process unit corresponding to the minimum and maximum scaling values for signals that are connected to the terminal.

Reference

In parameter 205 *Maximum reference, Ref_{MAX}* it is possible to preset a maximum reference that scales the sum of all references, i.e. the resulting reference.

The minimum reference in parameter 204 is an expression of the minimum value that the resulting reference can assume.

All references will be added together and the sum will be the reference against which regulation will take place. It is possible to limit the reference range to a range that is smaller than the feedback range. This can be an advantage if you want to avoid an unintentional

change to an external reference making the sum of the references move too far away from the optimal reference. The reference range cannot exceed the feedback range.

If preset references are desired, they are preset in parameters 215 to 216 *Preset reference*. See description *Reference Function and Handling of References* in parameter 214.

If a current signal is used as the feedback signal, it will only be possible to use voltage as an analogue reference. Use the overview below to determine which terminal is to be used and which parameters are to be programmed.

| Reference type | Terminal | Parameters |
|-------------------|----------|----------------------|
| Pulse | 3 | 333, 327 |
| Voltage | 2 | 332, 338, 339 |
| Current | 1 | 331, 336, 337 |
| Preset references | | 215-216 (241-247) |
| Bus reference | 68+69 | |

Note that the bus reference can only be preset via serial communication.



NB!

It is best to preset terminals that are not being used to *No function* [0].

Differentiator gain limit

If very rapid variations occur in an application in either the reference signal or the feedback signal, the deviation between the reference/setpoint and the process's actual mode will change quickly. The differentiator can then become too dominant. This is because it is reacting to the deviation between the reference and the process's actual mode, and the quicker the variance changes the more powerful the differentiator's frequency contribution becomes. The differentiator's frequency contribution can therefore be limited in such a way that both a reasonable differentiation time for slow changes and an appropriate frequency contribution for quick changes can be preset. This is done using parameter 443 *Process PID Differentiator gain limit*.

Lowpass filter

If there is a lot of noise in the feedback signal, these can be dampened using an integrated lowpass filter. A suitable lowpass filter time constant is preset.

If the lowpass filter is preset to 0.1 s, the cut-off frequency will be 10 RAD/sec, corresponding to $(10 / 2 \times \pi) = 1.6$ Hz. This will mean that all currents/voltages that vary by more than 1.6 oscillations per second will be dampened. In other words, there will only be regu-

lation on the basis of a feedback signal that varies by a frequency of less than 1.6 Hz. The appropriate time constant is selected in parameter 444 *Process PID lowpass filter time*.

Inverse regulation

Normal regulation means that the motor speed is increased when the reference/setpoint is greater than the feedback signal. If it is necessary to run inverse regulation, in which the speed is reduced when the reference/setpoint is greater than the feedback signal, parameter 437 *Process PID normal/inverse control* must be programmed at *Inverted*.

Anti Windup

In the factory the process regulator is preset with an active anti windup function. This function means that when either a frequency limit, a current limit or a voltage limit is reached, the integrator is initialised at a frequency corresponding to the present output frequency. This is a means of avoiding the integration of a variance between the reference and the process's actual mode that cannot be deregulated by means of a change of speed. This function can be deselected in parameter 438 *Process PID anti windup*.

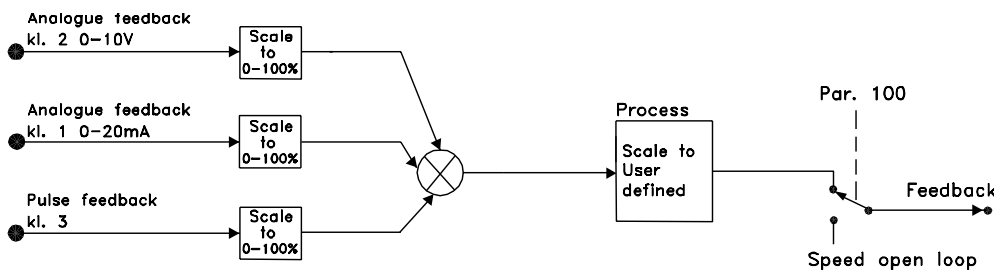

175NA123.10

Starting conditions

In some applications the optimal setting of the process regulator will mean that a relatively long period of time will pass before the required process condition is achieved. In these applications it can be a good idea to define an output frequency to which the frequency converter must run the motor before the process regulator is activated. This is done by programming a start frequency in parameter 439 *Process PID start frequency*.

■ Handling of feedback

Feedback handling is depicted in this flowchart.

The flowchart shows which parameters can affect the handling of feedback and how. A choice can be made between voltage, current and pulse feedback signals.

437 Process PID Normal/inverse control (PROC NO/INV CTRL)

Value:

- ★ Normal (NORMAL) [0]
- Inverse (INVERSE) [1]

Function:

It is possible to choose whether the process regulator is to increase/reduce the output frequency if there is a difference between the reference signal and the feedback signal.

Used together with *Process, closed loop mode* (parameter 100).

Description of choice:

If the FC motor is to reduce the output frequency in case the feedback signal increases, select *Normal* [0]. If the FC motor is to increase the output frequency in case the feedback signal increases, select *Inverse* [1].

438 Process PID anti windup (PROC ANTI WINDUP)

Value:

- Disable (DISABLE) [0]
- ★ Enable (ENABLE) [1]

Function:

It is possible to select whether the process regulator is to continue regulating on an error even if it is not possible to increase/reduce the output frequency. Used together with *Process, closed loop mode* (parameter 100).

Description of choice:

The factory setting is *Enable* [1], which means that the integration link is adjusted in relation to the actual output frequency if either the current limit or the max./min. frequency has been reached. The process regulator will not engage again until either the error is zero or its sign has changed.

Select *Disable* [0] if the integrator is to continue integrating on an error, even if it is not possible to remove the fault by such regulation.



NB!

If *Disable* [0] is selected, it will mean that when the error changes its sign, the integrator will first have to integrate down from the level obtained as a result of the former error, before any change to the output frequency occurs.

439 Process PID start frequency (PROC START VALUE)

Value:
 f_{MIN}-f_{MAX} (parameter 201 and 202) [X.X]
 ☆ parameter 201

Function:

When the start signal comes, the FC motor will react in the form of *Speed, open loop mode* following the ramp. Only when the programmed start frequency has been obtained, will it change over to *Process, closed loop mode*. In addition, it is possible to set a frequency that corresponds to the speed at which the process normally runs, which will enable the required process conditions to be reached sooner.

Used together with *Process, closed loop mode* (parameter 100).

Description of choice:

Set the required start frequency.



NB!

If the FC motor is running at the current limit before the desired start frequency is obtained, the process regulator will not be activated. For the regulator to be activated anyway, the start frequency must be lowered to the required output frequency. This can be done during operation.

440 Process PID proportional gain (PROC. PROP. GAIN)

Value:
 0.00 (OFF) - 10.00 [0 - 1000]
 ☆ 0.01 [1]

Function:

The proportional gain indicates the number of times the error between the set point and the feedback signal is to be applied.

Used together with *Process, closed loop mode* (parameter 100).

Description of choice:

Quick regulation is obtained by a high gain, but if the gain is too high, the process may become unstable.

441 Process PID integral time (PROC. INTEGR. T.)

Value:
 0.01 - 9999 sec. (OFF) [1 - 999900]
 ☆ 9999 sec. [999900]

Function:

The integrator provides an increasing gain at a constant error between the set point and the feedback signal. The greater the error, the quicker the gain will increase. The integral time is the time needed by the integrator to reach the same gain as the proportional gain.

Used together with *Process, closed loop mode* (parameter 100).

Description of choice:

Quick regulation is obtained at a short integral time. However, this time may become too short, which can make the process unstable.

If the integral time is long, major deviations from the required set point may occur, since the process regulator will take a long time to regulate in relation to a given error.

442 Process PID differentiation time (PROC. DIFF. TIME)

Value:
 0.00 (OFF) - 10.00 sec. [0 - 1000]
 ☆ 0.00 sec. [0]

Function:

The differentiator does not react to a constant error. It only provides a gain when the error changes. The quicker the error changes, the stronger the gain from the differentiator.

☆ = factory setting, () = display text, [] = value for use in communication via serial communication port

The gain is proportional to the speed at which the error changes.

Used together with *Process, closed loop mode* (parameter 100).

Description of choice:

Fast regulation is obtained with a long differentiation time. However, this time may become too long, which can make the process unstable.

443 Process PID diff. gain limit (PROC. DIFF. GAIN)

Value:

5.0 - 50.0 [50 - 500]

★ 5.0 [50]

Function:

It is possible to set a limit for the differentiator gain.

The differentiator gain will increase if there are fast changes, which is why it can be beneficial to limit this gain, thereby obtaining a pure differentiator gain at slow changes and a constant differentiator gain where quick changes to the error occur.

Used together with *Process, closed loop mode* (parameter 100).

Description of choice:

Select a limit to differentiator gain as required.

444 Process PID lowpass filter time (PROC. FILTER TIME)

Value:

0.02 - 10.00 sec [2 - 1000]

★ 0.02 sec [2]

Function:

Oscillations on the feedback signal are dampened by the lowpass filter in order to reduce their impact on the process regulation. This can be an advantage e.g. if there is a lot of noise on the signal.

Used together with *Process, closed loop mode* (parameter 100).

Description of choice:

Select the desired time constant (τ). If a time constant (τ) of 100 ms is programmed, the break frequency for

the lowpass filter will be $1/0.1 = 10$ RAD/sec., corresponding to $(10/2 \times \pi) = 1.6$ Hz.

The process regulator will thus only regulate a feedback signal that varies by a frequency lower than 1.6 Hz. If the feedback signal varies by a higher frequency than 1.6 Hz, the Process regulator will not react.

445 Flying start

(FLYING START)

Value:

★ Disable (DISABLE) [0]

OK - same direction (OK-SAME DIRECTION) [1]

OK - both directions (OK-BOTH DIRECTIONS) [2]

DC-brake before start
(DC-BRAKE BEF. START) [3]

Function:

This function makes it possible to 'catch' a motor, which is spinning freely because of a mains dropout.

Description of choice:

Select *Disable* if this function is not required.

OK - same direction: Chosen if the motor can only rotate in same direction on cut-in.

OK - both directions: Chosen if the motor can rotate in both directions on cut-in.

DC-brake - before start: Selected if the motor is to be stopped using DC brake before the motor is ramped up to the desired speed. The DC brake time must be set in parameter 126.

Limitations:

1. Too low inertia will cause acceleration of the load, which may be dangerous or prevent successful *Flying start*. Use DC brake instead.
2. If load is driven eg. by "windmilling", the unit might trip due to overvoltage.
3. Below 250 rpm the *Flying start* will not function.

446 Switching pattern

(SWITCH PATTERN)

Value:

60° AVM (60° AVM) [0]

★ SFAVM (SFAVM) [1]

Function:

Description of choice:

Normally it is not necessary for the customer to set this parameter.

455 Frequency range monitor (MON. FREQ. RANGE)

Value:

- Disable [0]
- ★ Enable [1]

Function:

This parameter is used if warning 35 *Out of frequency range* must be turned off in the display in process control closed loop. This parameter does not affect the extended status word.

Description of choice:

Select *Enable* [1] to enable the readout in the display if warning 35 *Out of frequency range* occurs. Select *Disable* [0] to disable the readout in the display if warning 35 *ut of frequency range* occurs.

461 Feedback conversion (FEEDBACK CONV.)

Value:

- ★ Linear (LINEAR) [0]
- Square root (SQUARE ROOT) [1]

Function:

In this parameter, a function is selected which converts a connected feedback signal from the process to a feedback value that equals the square root of the connected signal.

This is used, e.g. where regulation of a flow (volume) is required on the basis of pressure as feedback signal (flow = constant × √pressure). This conversion makes it possible to set the reference in such a way that there is a linear connection between the reference and the flow required. See drawing.

Description of choice:

If *Linear* [0] is selected, the feedback signal and the feedback value will be proportional.

If *Square root* [1] is selected, the frequency converter translates the feedback signal to be the square root value.

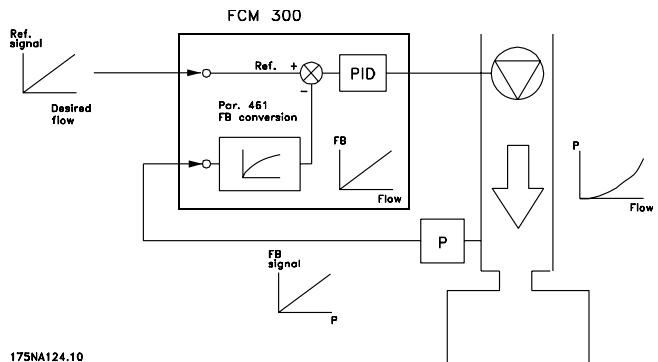

500 Address (BUS ADDRESS)

Value:

1 - 126 [1 -126]

★ 1 [1]

Function:

This parameter allows specification of the address of each FC motor. This feature is used in connection with PLC/PC connection.

Description of choice:

The individual FC motor can be given an address between 1 and 126. The address 0 is used if a master (PLC or PC) wishes to send a telegram that is to be received by all FC motors connected to the serial communication port at the same time. In this case, the FC motor will not acknowledge receipt. If the number of units connected (FC motors + master) exceeds 31, a repeater is required.

501 Baudrate (BAUDRATE)

Value:

300 Baud (300 BAUD) [0]

600 Baud (600 BAUD) [1]

1200 Baud (1200 BAUD) [2]

2400 Baud (2400 BAUD) [3]

4800 Baud (4800 BAUD) [4]

9600 Baud (9600 BAUD) [5]

Function:

This parameter is for programming the speed at which data is to be transmitted via the serial connection. Baud rate is defined as the number of bits transferred per second.

Description of choice:

The transmission speed of the FC motor is to be set at a value that corresponds to the transmission speed of the PLC/PC.



NB!

Can not be changed via LCP 2. LCP 2 is only capable to communicate at 9600 baud.

502 Coasting (COASTING SELECT)

503 Quick-stop (Q STOP SELECT)

504 DC-brake (DC BRAKE SELECT)

505 Start (START SELECT)

506 Reversing (REVERSING SELECT)

507 Selection of Setup (SETUP SELECT)

508 Selection of speed (PRES.REF. SELECT)

Value:

Digital input (DIGITAL INPUT) [0]

Bus (SERIAL PORT) [1]

Logic and (LOGIC AND) [2]

★ Logic or (LOGIC OR) [3]

Function:

Parameters 502-508 allow a choice between controlling the FC motor via the terminals (digital input) and/or via the bus.

If *Logic and* or *Bus* is selected, the command in question can only be activated if transmitted via the serial communication port. In the case of *Logic and*, the command must additionally be activated via one of the digital inputs.

Description of choice:

Digital input [0] is selected if the control command in question is only to be activated via a digital input.

Bus [1] is selected if the control command in question is only to be activated via a bit in the control word (serial communication).

Logic and [2] is selected if the control command in question is only to be activated when a signal is transmitted (active signal = 1) via both a control word and a digital input.

| Digital input | 505-508 | Bus | Control command |
|---------------|---------|-----|-----------------|
| | 0 | 0 | 0 |
| | 0 | 1 | 0 |
| | 1 | 0 | 0 |
| | 1 | 1 | 1 |

Logic or [3] is selected if the control command in question is to be activated when a signal is given (active signal = 1) either via a control word or via a digital input.

| Digital input 505-508 | Bus | Control command |
|--------------------------|-----|-----------------|
| 0 | 0 | 0 |
| 0 | 1 | 1 |
| 1 | 0 | 1 |
| 1 | 1 | 1 |



NB!

Parameters 502-504 deal with stop functions - see examples regarding 502 (coasting) below. Active stop command "0".

Parameter 502 = *Logic and*

| Digital input | Bus | Control command |
|---------------|-----|-----------------|
| 0 | 0 | 1 Coasting |
| 0 | 1 | 0 Motor running |
| 1 | 0 | 0 Motor running |
| 1 | 1 | 0 Motor running |

Parameter 502 = *Logic or*

| Digital input | Bus | Control command |
|---------------|-----|-----------------|
| 0 | 0 | 1 Coasting |
| 0 | 1 | 1 Coasting |
| 1 | 0 | 1 Coasting |
| 1 | 1 | 0 Motor running |

509 Bus jog 1

(BUS JOG 1 FREQ.)

Value:

0.0 - parameter 202 [0 -]

★ 10.0 HZ [100]

Function:

This is where to set a fixed speed (jog) that is activated via the serial communication port.

This function is the same as in parameter 213.

Description of choice:

The jog frequency f_{JOG} can be selected in the range between f_{MIN} (parameter 201) and f_{MAX} (parameter 202).

510 Bus jog 2

(BUS JOG 2 FREQ.)

Value:

0.0 - parameter 202 [0 -]

★ 10.0 HZ [100]

Function:

This is where to set a fixed speed (jog) that is activated via the serial communication port.

This function is the same as in parameter 213.

Description of choice:

The jog frequency f_{JOG} can be selected in the range between f_{MIN} (parameter 201) and f_{MAX} (parameter 202).

512 Telegram profile

(TELEGRAM PROFILE)

Value:

Fieldbus Profile (FIELDBUS PROFILE) [0]

★ FC Profile (FC PROFILE) [1]

Function:

There is a choice of two different control word profiles.

Description of choice:

Select the desired control word profile.

See *Serial communication* for further information about the control word profiles.



NB!

This is only possible in Stop Mode (motor stopped on a Stop command).

513 Bus time interval

(BUS TIMEOUT TIME)

Value:

1 - 99 sec. [1-99]

★ 1 sec. [1]

Function:

This parameter sets the maximum time expected to pass between the receipt of two consecutive telegrams. If this time is exceeded, the serial communication is assumed to have stopped and the desired reaction is set in parameter 514.

Description of choice:

Set the desired time.

**514 Bus time interval function
(BUS TIMEOUT FUNC)**
Value:

| | |
|-------------------------------|-----|
| ★ Off (OFF) | [0] |
| Freeze output (FREEZE OUTPUT) | [1] |
| Stop (STOP) | [2] |
| Jogging (JOGGING) | [3] |
| Max. speed (MAX SPEED) | [4] |
| Stop and trip (STOP AND TRIP) | [5] |

Function:

This parameter selects the desired reaction of the FC motor when the set time for bus timeout (parameter 513) has been exceeded. If choices [1] to [5] are activated, relay 01 and relay 04 will be de-activated.

Description of choice:

The output frequency of the FC motor can: be frozen at the present value, be frozen at the reference, go to stop, go to jogging frequency (parameter 213), go to max. output frequency (parameter 202) or stop and activate a trip.

**515 Data read-out: Reference %
(REFERENCE)**
Value:

XXX.X % [XXXX]

Function:

This parameter can be read out via the serial communication port.

Description of choice:

The value shown corresponds to the total reference (sum of digital/analogue/preset/bus/freeze ref./catch-up and slow-down).

This value is updated every 320 ms.

**516 Data read-out: Reference unit
(REFERENCE [UNIT])**
Value:

X.XXX Hz or rpm. [XXXX]

Function:

This parameter can be read out via the serial communication port.

Description of choice:

Indicates the status value of the unit given on the basis of the choice of the reference sum.

This value is updated every 320 ms.

**517 Data read-out: Feedback
(FEEDBACK [UNIT])**
Value:

X.XXX [XXXX]

Function:

This parameter can be read out via the serial communication port.

Description of choice:

Indicates the status value of terminals 1/2 at the unit/scale selected in parameters 414 and 415.

This value is updated every 320 ms.

**518 Data read-out: Frequency
(FREQUENCY)**
Value:

XXX.X Hz [XXXX]

Function:

This parameter can be read out via the serial communication port.

Description of choice:

The value shown corresponds to the actual motor frequency.

This value is updated every 320 ms.

**519 Data read-out: Frequency x scale
(FREQUENCY X SCALE)**
Value:

XXX.X Hz [XXXX]

Function:

This parameter can be read out via the serial communication port.

Description of choice:

The value corresponds to the present output frequency f_M multiplied by the factor preset in parameter 008 *Display scaling* of output frequency.

★ = factory setting, () = display text, [] = value for use in communication via serial communication port

VLT® FCM Series

520 Data read-out: Current (MOTOR CURRENT)

Value:

XXX.XX A [XXXXX]

Function:

This parameter can be read out via the serial communication port.

Description of choice:

The value shown is a calculated value of the given motor current.

This value is updated every 320 ms.

521 Data read-out: Torque (TORQUE)

Value:

XXX.X % [XXXX]

Function:

This parameter can be read out via the serial communication port.

Description of choice:

The value shown is the torque, with sign, supplied to the motor shaft. The value is given as a percentage of the rated torque.

There is not exact linearity between 160% motor current and torque in relation to the rated torque. Due to tolerances and temperature differences some motors supply more torque than that. Consequently, the min. value and the max. value will depend on the max./min. motor current.

This value is updated every 320 ms.

522 Data read-out: Power, kW (POWER (kW))

Value:

XX.XX kW [XXXX]

Function:

This parameter can be read out via the serial communication port.

Description of choice:

The value shown is calculated on the basis of the actual motor voltage and motor current.

This value is updated every 320 ms.

523 Data read-out: Power, HP (POWER (hp))

Value:

XX.XX HP (US) [XXXX]

Function:

This parameter can be read out via the serial communication port.

Description of choice:

The value shown is calculated on the basis of the actual motor voltage and motor current. The value is indicated in the form of HP.

This value is updated every 320 ms.

524 Data read-out: Motor voltage (MOTOR VOLTAGE)

Value:

XXX.X V [XXXX]

Function:

This parameter can be read out via the serial communication port.

Description of choice:

The value shown is a calculated value used for controlling the motor.

This value is updated every 320 ms.

525 Data read-out: DC link voltage (DC LINK VOLTAGE)

Value:

XXXX V [XXXX]

Function:

This parameter can be read out via the serial communication port.

Description of choice:

The value shown is a measured value.

The value is filtered, which means that approx. 1.3 seconds may pass from an input value changes until the data read-out changes values.

This value is updated every 320 ms.

**527 Data read-out: FC therm.
(FC THERMAL)**

Value:
0 - 100% [0 - 100]

Function:
This parameter can be read out via the serial communication port.

Description of choice:
Only whole numbers are displayed.
This value is updated every 160 ms.

**528 Data read-out: Digital input
(DIGITAL INPUT)**

Value:
Unit

Function:
This parameter can be read out via the serial communication port.

Description of choice:
The value shown indicates the signal status from the 4 digital terminals (2, 3, 4, and 5).
This value is updated every 20 ms.

**533 Data read-out: External reference %
(EXT. REFERENCE)**

Value:
-200.0 - +200.0 %

Function:
This parameter can be read out via the serial communication port.

Description of choice:
The value stated gives, as a percentage, the sum of external references (sum of analogue/bus/pulse).
This value is updated every 80 ms.

**534 Data read-out: Status word, binary
(STATUS WORD [HEX])**

Value:
Unit

Function:
This parameter can be read out via the serial communication port.

Description of choice:
Indicates the status word transmitted via the serial communication port.

**537 Data read-out: INV. temperature
(INVERTER TEMP.)**

Value:
Unit: °C

Function:
This parameter can be read out via the serial communication port.

Description of choice:
States the given temperature of the frequency converter. This value is updated every 10 sec.

**538 Data read-out: Alarm word
(ALARM WORD)**

Value:
Unit

Function:
This parameter can be read out via the serial communication port. See chapter on "Warnings and alarms".

Description of choice:
States whether there is an alarm on the FC motor.

★ = factory setting, () = display text, [] = value for use in communication via serial communication port

VLT® FCM Series

| Hex | Fault messages |
|----------|----------------------|
| 00000002 | Trip lock |
| 00000040 | HPFB timeout |
| 00000080 | Standard bus timeout |
| 00000100 | Short circuit |
| 00000200 | 24 V supply fault |
| 00000400 | Earth fault |
| 00000800 | Overcurrent |
| 00004000 | Motor thermistor |
| 00008000 | Inverter overload |
| 00010000 | Undervoltage |
| 00020000 | Overvoltage |
| 00040000 | Phase loss |
| 00080000 | Live zero error |
| 00100000 | Overtemperature |
| 02000000 | HPFB error |
| 08000000 | Inrush fault |
| 10000000 | Internal error |



NB!

This parameter is updated every 20 ms.

539 Data read-out: Control word

(CONTROL WORD)

Value:

Unit

Function:

This parameter can be read out via the serial communication port.

Description of choice:

Indicates the control word sent via the serial communication port in Hex code from the FC motor. This parameter is updated every 20 ms.

540 Data read-out: Warning word

(WARN. WORD)

Value:

Unit

Function:

This parameter can be read out via the serial communication port. See chapter on "Warnings and alarms".

Description of choice:

States in Hex format whether there is a warning on the FC motor.

| Hex | Warning messages |
|----------|----------------------------|
| 00000008 | HPFB timeout |
| 00000010 | Standard bus timeout |
| 00000040 | Current limit |
| 00000200 | Inverter overload |
| 00001000 | Voltage warning low |
| 00002000 | Voltage warning high |
| 00004000 | Phase loss |
| 00010000 | Live zero error warning |
| 00400000 | Output freq. limit warning |
| 00800000 | HPFB error |
| 40000000 | 24 V supply warning |
| 80000000 | Inverter temp. high |

541 Data read-out: Extended status word

(STATUS WORD)

540

Value:

Unit

Function:

This parameter can be read out via the serial communication port.

Description of choice:

States in Hex format whether there is a warning on the FC motor.

| Hex | Status messages |
|------|----------------------------------|
| 01 | Ramping |
| 04 | Start clockwise/counterclockwise |
| 08 | Slow down |
| 10 | Catch-up |
| 8000 | Frequency limit |

542 Data read-out: Terminal 1, analogue input

(ANALOG INPUT 1)

Value:

Unit: mA

Function:

This parameter can be read out via the serial communication port.

Description of choice:

The value shown indicates the signal value on terminal 1.

The scaling (parameters 336 and 337) does not influence the read-out. Min. and max. are determined by the offset and gain adjustment of the AD-converter.

This value is updated every 20 ms.

| | |
|------------|--|
| 543 | Data read-out: Terminal 2, analogue input |
|------------|--|

| |
|-------------------------|
| (ANALOG INPUT 2) |
|-------------------------|

| |
|---------------|
| Value: |
|---------------|

Unit: X.X V

| |
|------------------|
| Function: |
|------------------|

This parameter can be read out via the serial communication port.

| |
|-------------------------------|
| Description of choice: |
|-------------------------------|

The value shown indicates the signal value on terminal 2.

The scaling (parameters 338 and 339) does not influence the read-out. Min. and max. are determined by the offset and gain adjustment of the AD-converter.

This value is updated every 20 ms.

600 Operating data: Operating hours (OPERATING HOURS)

Value:

Unit: hours
0.0 - 130,000.0

Function:

This parameter can be read out via the display or the serial communication port. The value cannot be reset.

Description of choice:

Indicates the number of hours in which the FC motor has been switched on.

The value is updated in the FC motor every hour and saved when the unit is turned off.

601 Operating data: Hours run (RUNNING HOURS)

Value:

Unit: hours
0.0 - 130,000.0

Function:

This parameter can be read out via the display or the serial communication port. The value can be reset via parameter 619.

Description of choice:

Indicates the number of hours in which the FC motor has been in operation since reset in parameter 619.

The value is updated in the FC motor every hour and saved when the unit is turned off.

603 Operating data: Number of power-up's (POWER UP'S)

Value:

Unit: number
0 - 9999

Function:

This parameter can be read out via the display or the serial communication port.

Description of choice:

States the number of power-ups of the supply voltage to the FC motor.

604 Operating data: Number of overtemperatures (OVER TEMP'S)

Value:

Unit: number
0 - 9999

Function:

This parameter can be read out via the display or the serial communication port.

Description of choice:

States the number of temperature faults there has been on the FC motor.

605 Operating data: Number of overvoltages (OVER VOLT'S)

Value:

Unit: number
0 - 9999

Function:

This parameter can be read out via the display or the serial communication port.

Description of choice:

States the number of overvoltages there has been on the FC motor.



NB!

Parameters 615-617 *Fault log* cannot be read out via the integral control unit.

615 Fault log: Error code (F.LOG: ERROR COD)

Value:

[Index 1 - 10] Error code: 0 - 99

Function:

In this parameter it is possible to see the reason for a trip (cut-out of the frequency converter) occurring. 10 [1-10] log values are defined.

The lowest log number [1] contains the latest/most recently saved data value. The highest log number [10] contains the oldest data value saved. If a trip occurs,

it is possible to see the cause, time and a possible value of the output current or output voltage.

Description of choice:

Given as a fault code, in which the number refers to a table. See the table in *Warnings/alarm messages*.

616 Fault log: Time

(F.LOG: TIME)

Value:

Unit: Hours

[Indication range XX - XXX]

Function:

Array type parameter. This parameter makes it possible to see the total number of operating hours before the trip occurred. 10 (1-10) log values are stored.

The lowest log number (1) contains the latest/most recently saved data value, while the highest log number (10) contains the oldest data value.

Description of choice:

Read out as an option.

Indication range: XX - XXX.

The fault log is reset after initialization (para. 620).

617 Fault log: Value

(F.LOG: VALUE)

Value:

[Index XX - XXX]

Function:

Array type parameter. This parameter makes it possible to see at what current or voltage a given trip occurred.

Description of choice:

Read out as one value.

Indication range: 0.0 - 999.9.

The fault log is reset after initialisation (para. 620).

619 Reset of hours-run counter

(RESET RUN. HOUR)

Value:

★ No reset (DO NOT RESET) [0]

Reset (RESET COUNTER) [1]

Function:

Reset to zero of hours-run counter (parameter 601).

Description of choice:

If *Reset* [1] has been selected the hours-run counter of the FC motor is reset.

620 Operating mode

(OPERATION MODE)

Value:

Normal function (NORMAL OPERATION) [0]

Control card test (CONTROL CARD TEST) [2]

Initialisation (INITIALIZE) [3]

Function:

In addition to its normal function, this parameter can be used for two different tests.

Also, all parameters (except parameters 603-605) can be initialized.

Description of choice:

Normal function [0] is selected for normal operation with the motor in the selected application.

Control card test [2] is selected if control of the analogue and digital inputs, as well as the analogue, digital outputs and the +10 V control voltage is desired.

A test connector with internal connections is required for this test. Setup: Analogue/digital output to digital inputs 3, 4 and 5 and 10 V supply to analogue/digital input 2.

Initialization [3] is selected if the factory setting of the unit is desired without resetting parameters 500, 501 + 600 - 605. Initialisation is active after power up.

621 Nameplate: FC type

(FC TYPE)

Value:

Depends on unit

Function:

The key data of the unit can be read out via the display or the serial communication.

Description of choice:

Type indicates the unit size and basic function concerned.

VLT® FCM Series

**624 Nameplate: Software version no.
(SOFTWARE VERSION)**

Value:

Depends on unit

Function:

The key data of the unit can be read out via the display or the serial communication.

Description of choice:

Software version gives the version number.

**625 Nameplate: LCP identification no.
(LCP VERSION)**

Value:

Depends on unit

Function:

The key data of the unit can be read out via the display or the serial communication port. For example: ID 1,42 2 kB.

**626 Nameplate: Database identification no.
(DATABASE VER.)**

Value:

Depends on unit

Function:

The key data of the unit can be read out via the display or the serial communication port.

**628 Nameplate: Application option type
(APP. OPTION)**

Value:

Function:

The key data of the unit can be read out via the display or the serial communication port.

**630 Nameplate: Communication option
type ordering no.
(COM. ORDER NO)**

Value:

Function:

The key data of the unit can be read out via the display or the serial communication port.

**632 BMC software identification
(BMC SW VERSION)**

Value:

Function:

The key data of the unit can be read out via the display or the serial communication port.

**633 Motor database identification
(MOTOR DATA VERS.)**

Value:

Function:

The key data of the unit can be read out via the display or the serial communication port.

**634 Unit identification for communication
(UNIT ID)**

Value:

Function:

The key data of the unit can be read out via the display or the serial communication port.

**678 Configure Control Card
(CONFIG CONTROL CARD)**

Value:

Standard version (STANDARD VERSION) [1]
Profibus 3 Mbaud Version
(PROFIBUS 3 MB VER.) [2]

Profibus 12 Mbaud Version
(PROFIBUS 12 MB VER.) [3]

Function:

This parameter enables a configuration of a Profibus Control Card. The default value depends on the produced unit, also being the maximum obtainable value. This means, that a control card only can be down graded to a lower performance version.

■ PC Software tools

PC Software - MCT 10

All drives are equipped with a serial communication port. We provide a PC tool for communication between PC and frequency converter, VLT Motion Control Tool MCT 10 Set-up Software.

MCT 10 Set-up Software

MCT 10 has been designed as an easy to use interactive tool for setting parameters in our frequency converters.

The MCT 10 Set-up Software will be useful for:

- Planning a communication network off-line. MCT 10 contains a complete frequency converter database
- Commissioning frequency converters on line
- Saving settings for all frequency converters
- Replacing a drive in a network

- Expanding an existing network
- Future developed drives will be supported

The MCT 10 Set-up Software Modules

The following modules are included in the software package:



MCT 10 Set-up Software

Setting parameters
Copy to and from frequency converters
Documentation and print out of parameter settings incl. diagrams

SyncPos

Creating SyncPos programme

Ordering number:

Please order your CD containing MCT 10 Set-up Software using code number 130B1000.

■ Serial bus

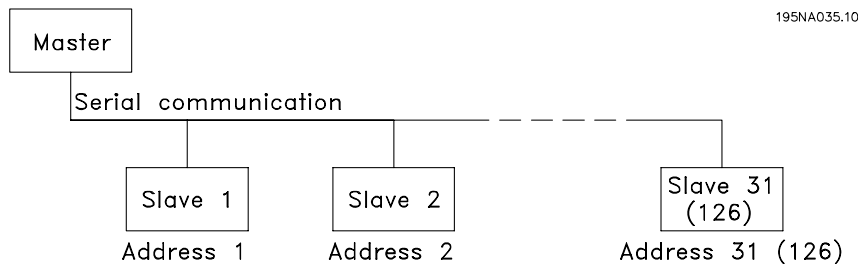

■ Telegram communication

Control and reply telegrams

The telegram communication in a master/slave SYSTEM is controlled by the master. A maximum of 31 slaves (FC motors) can be connected to one master, unless a repeater is used - see also the description of the address format.

The master continuously sends control telegrams addressed to the slaves and awaits reply telegrams from these. The response time of the slaves is maximum 50 ms.

Only a slave that has received a faultless telegram addressed to that slave will respond by sending back the telegram unchanged.

Broadcast

A master can send the same telegram at the same time to all slaves connected to the bus. In such *broadcast* communication, the control telegram *broadcast* bit of the address bit has a value of 1 (see VLT address). Address bits 0-4 are not used.

Contents of a byte

Each transmitted sign begins with a start bit. Subsequently, 8 databits are transmitted. Each sign is given via a parity bit set at "1" when there is an even parity (i.e. an even number of binary 1's in the 8 databits and parity bits together). The sign ends with a stop bit and thus consists of a total of 11 bits.

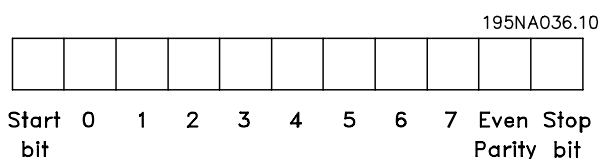

■ Telegram build-up

Each telegram begins with a startbyte (STX) = 02 Hex, followed by a byte that gives the telegram length (LGE) and a byte that gives the address (ADR). Then follows a number of databytes (variable, depending on telegram type). The telegram ends with a data control byte (BCC).

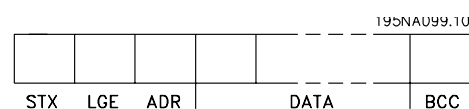

Telegram length (LGE)

The telegram length is the number of databytes plus address byte ADR plus data control byte BCC.

Telegrams with 4 databytes have a length of:

$$LGE = 4 + 1 + 1 = 6 \text{ bytes}$$

Telegrams with 12 databytes have a length of:

$$LGE = 12 + 1 + 1 = 14 \text{ bytes}$$

VLT address (ADR)

Two different address formats are used:

1. Siemens USS protocol address format:

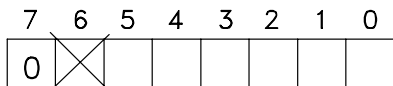

195NA040.10

Bit 7 = 0

Bit 6 is not used

Bit 5 = 1: Broadcast, address bits (0-4) are not used

Bit 5 = 0: No Broadcast

Bits 0-4 = VLT address 1-31

2. Danfoss format:

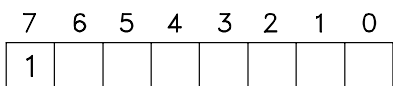

195NA041.10

Bit 7 = 1

Bits 0-6 = VLT address 1-127 (0 = Broadcast)

Data control byte (BCC)

The data control byte can best be explained by means of an example: Before the first sign of the telegram is received, BCC = 0.

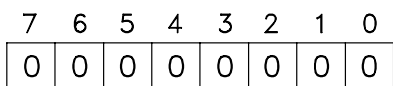

195NA043.10

After the first sign has been received:

$$BCC_{NEW} = BCC_{OLD} \text{ EXOR "first byte"}$$

(EXOR = exclusive-or gate)

$$BCC_{OLD} = 00000000$$

EXOR

$$\text{"first byte"} = 00000010 \text{ (02H)}$$

$$BCC_{NEW} = 00000010$$

Each additional, subsequent byte is gated by

BCC_{OLD} EXOR and gives a new BCC_{NEW} , e.g.:

$$BCC_{OLD} = 00000010$$

EXOR

$$\text{"second byte"} = 11010110 \text{ (D6H)}$$

$$BCC_{NEW} = 11010100$$

The result after the last received sign is BCC.

■ Databytes

The block of databytes is divided into two smaller blocks:

1. Parameter bytes used for transferred parameters between master and slave
2. Process bytes, covering
 - Control word and reference value (from master to slave)
 - Status word and present output frequency (from slave to master)

This structure applies to both the control telegram (master \Rightarrow slave) and the reply telegram (slave \Rightarrow master).

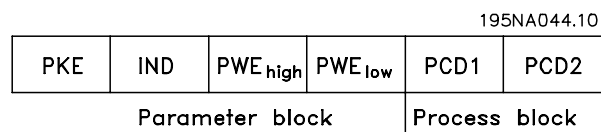

There are two types of telegrams:

- with 12 bytes built up as shown above, with parameter and process block
- with four bytes, which is the process block from the 12 byte telegram

1. Parameter bytes

195NA046.10

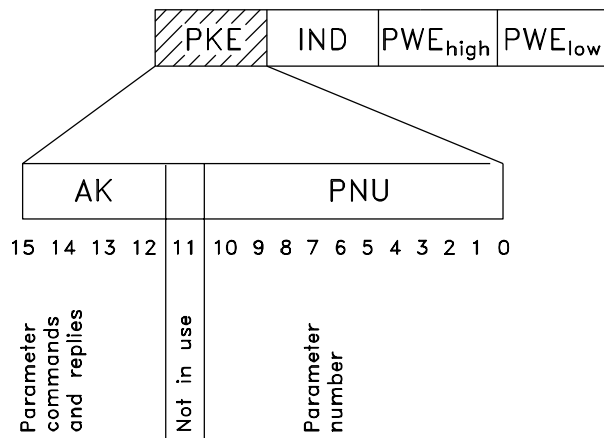

Commands and replies (AK)

Bits no. 12-15 are used for transmitting commands from master to slave and the slave's processed reply back to the master.

Commands master \Rightarrow slave:

Bit no.

| 15 | 14 | 13 | 12 | Command |
|----|----|----|----|---|
| 0 | 0 | 0 | 0 | No command |
| 0 | 0 | 0 | 1 | Read parameter value |
| 0 | 0 | 1 | 0 | Write parameter value in RAM (word) |
| 0 | 0 | 1 | 1 | Write parameter value in RAM (double word) |
| 1 | 1 | 0 | 1 | Write parameter value in RAM and EEPROM (double word) |
| 1 | 1 | 1 | 0 | Write parameter value in RAM and EEPROM (word) |
| 1 | 1 | 1 | 1 | Read text |

Reply slave • master:

Bit no.

| 15 | 14 | 13 | 12 | Reply |
|----|----|----|----|---|
| 0 | 0 | 0 | 0 | No reply |
| 0 | 0 | 0 | 1 | Parameter value transferred (word) |
| 0 | 0 | 1 | 0 | Parameter value transferred (double word) |
| 0 | 1 | 1 | 1 | Command cannot be executed |
| 1 | 1 | 1 | 1 | Text transferred |

If the command cannot be executed, the slave will send this reply (0111) and give the following error message in the parameter value:

Error code

(reply 0111) Error message

| | |
|-----|--|
| 0 | The parameter number used does not exist |
| 1 | There is no write access to the parameter called |
| 2 | The data value exceeds the parameter limits |
| 3 | The used sub-index does not exist |
| 4 | The parameter is not of the array type |
| 5 | The data type does not match the parameter called |
| 17 | Data change in the parameter called is not possible in the present mode of the FC motor. E.g. some parameters can only be changed when the motor has stopped |
| 130 | There is no bus access to the parameter called |
| 131 | Data change is not possible because factory Setup has been selected |

Parameter number (PNU)

Bits no. 0-10 are used for transmitting parameter numbers. The function of a given parameter can be seen from the parameter description in chapter 8.

1/5NA114.10

| | | |
|-----|-----|-----|
| PKE | IND | PWE |
|-----|-----|-----|

Index

Index is used together with the parameter number for read/write access to parameters of the *array* type (par. 615, 616 and 617).

Parameter value (PWE)

1/5NA115.10

| | | |
|-----|-----|-----|
| PKE | IND | PWE |
|-----|-----|-----|

The parameter value depends on the command given. If the master wants a parameter (read), it does not care about the PWE block value. If a parameter is changed by the master (write), the new value is transferred in the PWE block. If the slave replies to a parameter request (read command), the present parameter value is transferred to the PWE block.

The transferred value corresponds to the figures given in the parameter descriptions in chapter 8. E.g. parameter 101, where [1] corresponds to *Constant torque*, [2] corresponds to *Variable torque: low*, etc. However, parameters with data type 9 (text string) are excepted, as this text is transferred as an ASCII text string. When a text string is transferred (read), the telegram length is variable, since the texts have different lengths. The telegram length is stated in the 2nd byte of the telegram, called LGE, see page 73. Parameters 621-634 (nameplate data) have data type 9 (text string).

Data types supported by the VLT frequency converter

| Data type | Description |
|-----------|-------------|
| 3 | Integer 16 |
| 4 | Integer 32 |
| 5 | Unsigned 8 |
| 6 | Unsigned 16 |
| 7 | Unsigned 32 |
| 9 | Text string |

Unsigned means there is no sign included in the telegram.

The different attributes for each parameter can be seen in the section on factory settings. Since a parameter value can only be transferred as an integer, a conversion factor must be used to transfer decimals.

Example:

Parameter 201: minimum frequency, conversion factor 0,1. If parameter 201 is to be set to 10 Hz, a value of 100 must be transferred, since a conversion factor of

0,1 means that the transferred value will be multiplied by 0.1. A value of 100 will thus be understood as 10.

Addressing by unit ID

The unit ID is printed on the label on the plastic cover under the lid of the electronics box. The three groups of unit ID each with three digits must be converted to

Hex. The desired address is added as the last byte. The frame is sent to the bus address parameter(s) 500 (and 918) via a broadcast.

PKE: Write to parameter No. 500 or 918
IND: Not Used

2. Process-bytes

The process byte block is divided into two blocks each of 16 bits, which always come in the sequence stated.

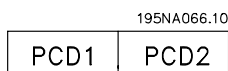

| | PCD1 | PCD2 |
|---------------------------------|--------------|------------------------|
| Control telegram (master⇒slave) | Control word | Reference value |
| Reply telegram (slave⇒master) | Status word | Given output frequency |

■ Control word according to Fieldbus Profile Standard

(parameter 512 = Fieldbus Profile) The control word is used for transmitting commands from a master (e.g. a PC) to a slave (FC motor).

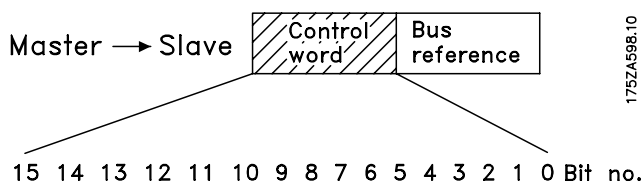

| Bit | Bit = 0 | Bit = 1 |
|-----|-------------------------|---|
| 00 | OFF 1 | ON 1 |
| 01 | OFF 2 | ON 2 |
| 02 | OFF 3 | ON 3 |
| 03 | Motor coasting | Enable |
| 04 | Quick-stop | Ramp |
| 05 | Freeze output frequency | Ramp enable |
| 06 | Ramp stop | Start |
| 07 | No function | Reset |
| 08 | Jog 1 OFF | ON |
| 09 | Jog 2 OFF | ON |
| 10 | Data not valid | Valid |
| 11 | No function | Slow down / Relay 123 / Digital output terminal 9 |
| 12 | No function | Catch-up / Relay 123 |
| 13 | Setup 1 | Setup 2 |
| 14 | | |
| 15 | No function | Reversing |



NB!

The use of Bit 00, Bit 01 and Bit 02 for switching off the power supply (by use of relay) will require a separate power on. This because there is no 24V external connection to supply the FCM 300 control, which is required to activate the FCM 300 again via input signal.

Bit 00, OFF1/ON1:

An ordinary ramp stop which uses the ramp time in parameters 207/208. Bit 00 = "0" leads to a stop. Bit 00 = "1" means that the frequency converter will be able to start if the other conditions for starting have been fulfilled.

Bit 01, OFF2/ON2:

Coasting stop. Bit 01 = "0" leads to a coasting stop. Bit 01 = "1" means that the frequency converter is able to start, provided the other conditions for starting have been fulfilled.

Bit 02, OFF3/ON3:

Quick-stop, which uses the ramp time in parameter 212. Bit 02 = "0" leads to a quick-stop. Bit 02 = "1" means that the frequency converter is able to start, provided the other conditions for starting have been fulfilled.

Bit 03, Coasting/enable:

Coasting. Bit 03 = "0" leads to a stop. Bit 03 = "1" means that the frequency converter is able to start, provided the other conditions for starting are fulfilled. Note: In parameter 502 the choice is made as to how bit 03 is to be combined (gated) with the corresponding function in the digital inputs.

Bit 04, Quick-stop/ramp:

Quick-stop which uses the ramp time in parameter 212. Bit 04 = "0" leads to a quick-stop. Bit 04 = "1" means that the frequency converter is able to start, provided the other conditions for starting are fulfilled. Note: In parameter 503 the choice is made as to how bit 04 is to be combined (gated) with the corresponding function on the digital inputs.

Bit 05, Freeze output frequency/ramp enable:

Bit 05 = "0" means that the given output frequency is maintained even if the reference is changed. Bit 05 = "1" means that the frequency converter is again able to regulate, and the given reference is followed.

Bit 06, Ramp stop/start:

An ordinary ramp stop that uses the ramp time in parameters 207/208. Bit 06 = "0" leads to a stop. Bit 06 = "1" means that the frequency converter is able to start, provided the other conditions for starting have been fulfilled. Note: In parameter 505 the choice is made as to how bit 06 is to be combined (gated) with the corresponding function on the digital inputs.

Bit 07, No function/reset

Reset of trip. Bit 07 = "0" means that there is no reset. Bit 07 = "1" means that a trip is reset. After reset it will take approx. 1.5 second until the unit is ready. The status word will indicate the ready state.

Bit 08, Jog 1 OFF/ON:

Activation of pre-programmed speed in parameter 509 (Bus JOG 1). JOG 1 is only possible when Bit 04 = "0" and bit 00-03 = "1".

Bit 09, Jog 2 OFF/ON:

Activation of pre-programmed speed in parameter 510 (Bus JOG 2). JOG 2 is only possible when Bit 04 = "0" and Bits 00-03 = "1". If both JOG 1 and JOG 2 are activated (Bits 08 and 09 = "1"), JOG 1 has the higher priority, which means that the speed programmed in parameter 509 will be used.

Bit 10, Data not valid/valid:

Used for telling the FC motor whether the control word is to be used or ignored. Bit 10 = "0" means that the control word is ignored. Bit 10 = "1" means that the control word is used. This function is relevant because the control word is always contained in the telegram, regardless of the type of telegram used, i.e. it is possible to disconnect the control word if it is not to be used in connection with updating or reading of parameters.

Bit 11, No function / slow down, relay 123, digital output terminal 9:

Used for reducing the speed reference by the value in parameter 219. Bit 11 = "0" means that there is no

change of the reference. Bit 11 = "1" means that the reference is reduced. Bit 11 = "1" will also activate relay 123 (provided parameter 323 = "Control word bit 11") and set digital out terminal 9 high (provided parameter 340 = "Control word bit 11").

Bit 12, No function / catchup, relay 123:

Used for increasing the speed reference by the value of parameter 219. Bit 12 = "0" means that there is no change of the reference; Bit 12 = "1" means that the reference is increased. If both slow down and catchup are activated (Bits 11 and 12 = "1"), slow down has the higher priority, i.e. the speed reference is reduced. Bit 12 = "1" will also activate relay 123 (provided parameter 323 = "Control word bit 12").

Bits 13, Choice of Setup:

Bit 13 is used for choosing between the two menu Setups in accordance with the following table:

| Setup | Bit 13 |
|-------|--------|
| 1 | 0 |
| 2 | 1 |

This function is only possible if *Multi-Setups* have been selected in parameter 004.



NB!

Parameter 507 is used for choosing how Bit 13 is to be combined (gated) with the corresponding function on the digital inputs.

Bit 15, No function/reversing:

Reversing of the direction of rotation of the motor. Bit 15 = "0" leads to no reversing, Bit 15 = "1" leads to reversing.



NB!

Unless otherwise mentioned, the control word bit is combined (gated) with the corresponding function on the digital inputs as a logic "or" function.

Status word (according to Fieldbus Profile standard)

The status word is used for informing the master (e.g. a PC) of the condition of a slave (FC motor).

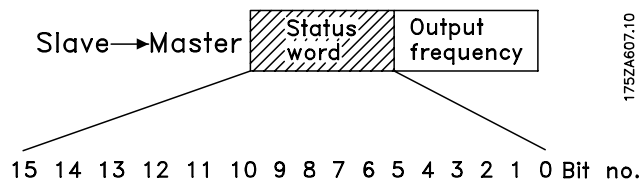

175ZA607.10

| Bit | Bit = 0 | Bit = 1 |
|-----|-------------------------|----------------------|
| 00 | Control not ready | Ready |
| 01 | FC not ready | Ready |
| 02 | Coasting | Enable |
| 03 | No fault | Trip |
| 04 | ON 2 | OFF 2 |
| 05 | ON 3 | OFF 3 |
| 06 | Start enable | Start disable |
| 07 | No warning | Warning |
| 08 | Speed ≠ ref. | Speed = ref. |
| 09 | Local control | Serial communication |
| 10 | Outside frequency range | Frequency limit OK |
| 11 | Not running | Running |
| 12 | | |
| 13 | Voltage OK | Above limit |
| 14 | Current OK | Above limit |
| 15 | | Thermal warning |

Bit 00, Control not ready/ready:

Bit 00 = "0" means that bit 00, 01 or 02 of the control word is "0" (OFF1, OFF2 or OFF3), or that the frequency converter has tripped. Bit 00 = "1" means that the frequency converter control is ready.

Bit 01, FC not ready/ready:

Same meaning as bit 00; however, there is also a supply to the power section, and the frequency converter is ready to run when it receives the necessary start signals.

Bit 02, Coasting/enable:

Bit 02 = "0" means that the control word bit 00, 01, 02 or 03 is "0" (OFF1, OFF2, OFF3 or Coasting), or the FCM 300 Series unit has tripped. Bit 02 = "1" means that the control word bits 00, 01, 02 or 03 are "1" and that the FC motor has not tripped.

Bit 03, No fault/trip:

Bit 03 = "0" means that FCM 300 Series is not in a fault condition. Bit 03 = "1" means that FCM 300 Series has tripped and needs a reset signal in order to run.

Bit 04, ON2/OFF2:

Bit 04 = "0" means that control word bit 01 = "1". Bit 04 = "1" means that control word bit 01 = "0".

Bit 05, ON3/OFF3:

Bit 05 = "0" means that control word bit 02 = "1". Bit 05 = "1" means that control word bit 02 = "0".

Bit 06, Start enable/start disable:

Bit 06 is always "0" if FC Drive has been selected in parameter 512. If *Profidrive* has been selected in parameter 512, bit 06 will be "1" after reset of a trip, after activation of OFF2 or OFF3 and after connection of mains voltage. Start disable is reset, setting control word bit 00 to "0" and bits 01, 02 and 10 to "1".

Bit 07, No warning/warning:

Bit 07 = "0" means that there is no unusual situation. Bit 07 = "1" means that an abnormal condition has arisen for the FC motor. All warnings described in section *List of warnings and alarms* will set bit 07 to "1".

Bit 08, Speed • ref/speed. = ref.:

Bit 08 = "0" means that the actual motor speed is different from the speed reference set. This can be the case i.a. while the speed is ramped up/down during start/stop. Bit 08 = "1" means that the present motor speed equals the speed reference set.

Bit 09, Local operation / serial communication control:

Bit 09 = "0" means that [STOP/RESET] is activated on the control unit, or that *Local control* in parameter 002 *Local/remote operation* is selected. It is not possible to control the frequency converter via serial communication. Bit 09 = "1" means that it is possible to control the frequency converter via serial communication.

Bit 10, Outside frequency range:

Bit 10 = "0", if the output frequency has reached the value in parameter 201 *Output frequency low limit* or parameter 202 *Output frequency high limit*. Bit 10 = "1" means that the output frequency is within the defined limits.

Bit 11, Not running/running:

Bit 11 = "0" means that the motor is not running. Bit 11 = "1" means that the FC motor has a start signal or that the output frequency is greater than 0 Hz.

Bit 13, Voltage OK/above limit:

Bit 13 = "0" means that the voltage limits of the FC motor have not been exceeded. Bit 13 = "1" means that the DC voltage of the FC motor intermediate circuit is too low or too high.

Bit 14, Current OK / above limit:

Bit 14 = "0" means that the motor current is lower than the current limit selected in parameter 221. Bit 14 = "1" means that the current limit in parameter 221 has been exceeded.

Bit 15, Thermal warning:

Bit 15 = "0" means that the timers for motor thermal protection and VLT thermal protection, respectively, have not exceeded 100%. Bit 15 = "1" means that one of the timers has exceeded 100%.

Control word under FC Profile (parameter 512 = FC Drive)

The control word is used for sending commands from a master (e.g. a PC) to a slave (FC motor).

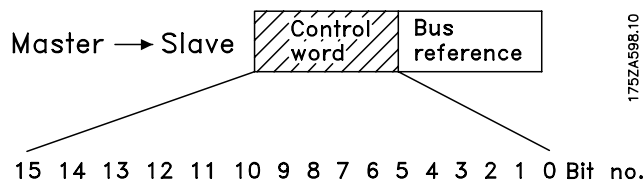

| Bit | Bit = 0 | Bit = 1 |
|-----|-------------------------|--------------------------------------|
| 00 | Preset reference choice | |
| 01 | No function | |
| 02 | DC brake | Ramp |
| 03 | Coasting | Enable |
| 04 | Quick-stop | Ramp |
| 05 | Hold | Ramp enable |
| 06 | Ramp stop | Start |
| 07 | No function | Reset |
| 08 | No function | Jog |
| 09 | No function | |
| 10 | Data not valid | Valid |
| 11 | No function | Relay 123 / digital input terminal 9 |
| 12 | No function | Relay 123 |
| 13 | Setup 1 | Setup 2 |
| 15 | No function | Reversing |

Bit 00:

Bit 00 is used for choosing between the two pre-programmed references (parameters 215-216) in accordance with the following table:

| Preset ref. | Parameter | Bit 00 |
|-------------|-----------|--------|
| 1 | 215 | 0 |
| 2 | 216 | 1 |



NB!

Parameter 508 is where to choose the way bits 1/12 are to be combined (gated) with the corresponding function on the digital inputs.

Bit 02, DC brake:

Bit 02 = "0" leads to DC braking and stop. Braking current and duration are set in parameters 132 and 133. Bit 02 = "1" leads to *ramp*.

Bit 03, Coasting/enable:

Coasting. Bit 03 = "0" leads to a stop. Bit 03 = "1" means that the frequency converter is able to start, provided the other conditions for starting have been

fulfilled. Note: In parameter 502 the choice is made as to how bit 03 is to be combined (gated) with the corresponding function in the digital inputs.

Bit 04, Quick-stop / ramp:

Quick-stop which uses the ramp time in parameter 212. Bit 04 = "0" leads to a quick-stop. Bit 04 = "1" means that the frequency converter is able to start, provided the other conditions for starting have been fulfilled. Note: In parameter 503 the choice is made as to how bit 04 is to be combined (gated) with the corresponding function on the digital inputs.

Bit 05, Hold / ramp enable:

Bit 05 = "0" means that the given output frequency is maintained even if the reference is changed. Bit 05 = "1" means that the frequency converter is again able to regulate, and the given reference is followed.

Bit 06, Ramp stop / start:

An ordinary ramp stop that uses the ramp time in parameters 207/208. Bit 06 = "0" leads to a stop. Bit 06 = "1" means that the frequency converter is able to start, provided the other conditions for starting have been fulfilled. Note: In parameter 505 the choice is made as to how bit 06 is to be combined (gated) with the corresponding function on the digital inputs.

Bit 07, No function / reset:

Reset of trip. Bit 07 = "0" means that there is no reset. Bit 07 = "1" means that a trip is reset. After reset it will take approx. 1.5 second until the unit is ready. The status word will indicate the ready state.

Bit 08, Activation of Jog speed in parameter 213:

Bit 08 = "0": Jog speed not activated. Bit 08 = "1" means that the motor is running at Jog speed.

Bit 10, Data not valid / valid:

Used for telling the FC motor whether the control word is to be used or ignored. Bit 10 = "0" means that the control word is ignored. Bit 10 = "1" means that the control word is used. This function is relevant because the control word is always contained in the telegram, regardless of the type of telegram used, i.e. it is possible to disconnect the control word if it is not to be used in connection with updating or reading of parameters.

Bit 11, No function / relay 123, digital output terminal 9:

Bit 11 = "1" will activate relay 123 (provided parameter 323 = "Control word bit 11") and set digital out terminal 9 high (provided parameter 340 = "Control word bit 11").

Bit 12, No function / relay 123:

Bit 12 = "1" will activate relay 123 (provided parameter 323 = "Control word bit 12").

Bit 13, Choice of setup:

Bit 13 is used for choosing between the two menu setups in accordance with the following table:

| Setup | Bit 13 |
|-------|--------|
| 1 | 0 |
| 2 | 1 |

This function is only possible if *Multi-Setups* have been selected in parameter 004.



NB!

Parameter 507 is used for choosing how Bit 13 is to be combined (gated) with the corresponding function on the digital inputs.

Bit 15, No function / reversing::

Reversing of the direction of rotation of the motor. Bit 15 = "0" leads to no reversing. Bit 15 = "1" leads to reversing..



NB!

Unless otherwise mentioned, the control word bit is combined (gated) with the corresponding function on the digital inputs as a logic "or" function.

Status word under FC Profile

The status word is used for informing the master (e.g. a PC) about the condition of the slave (FC motor).

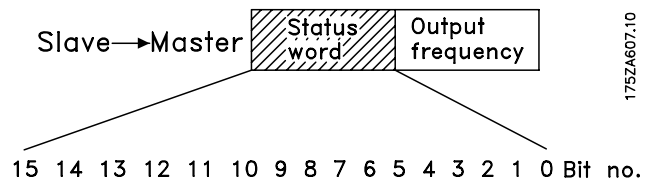

| Bit | Bit = 0 | Bit = 1 |
|-----|-------------------|-----------------|
| 00 | Control not ready | Ready |
| 01 | FC not ready | Ready |
| 02 | Coasting | Enable |
| 03 | No fault | Trip |
| 04 | Reserved | |
| 05 | Reserved | |
| 06 | Reserved | |
| 07 | No warning | Warning |
| 08 | Speed ≠ ref. | Speed = ref. |
| 09 | Local control | Bus control |
| 10 | Out of range | Frequency OK |
| 11 | Not running | Running |
| 12 | | |
| 13 | Voltage OK | Above limit |
| 14 | Current OK | Above limit |
| 15 | Timer OK | Thermal warning |

Bit 01, FC not ready/ready:

Bit 01 = "0" means that the frequency converter has tripped.

Bit 01 = "1" means that the frequency converter is ready.

Bit 02, Coasting/enable:

Bit 02 = "0" means that the control word bit 03 is "0" (Coasting) or that the FC motor has tripped.

Bit 02 = "1" means that control word bit 03 is "1" and that the FC motor has not tripped.

Bit 03, No fault / trip:

Bit 03 = "0" means that FCM 300 Series is not in a fault condition. Bit 03 = "1" means that FCM 300 Series has tripped and needs a reset signal in order to run.

Bit 07, No warning / warning:

Bit 07 = "0" means that there is no unusual situation. Bit 07 = "1" means that an abnormal condition has arisen for the FC motor. All warnings described in the part *List of warnings and alarms* will set bit 07 to "1".

Bit 08, Speed • ref/speed. = ref.:

Bit 08 = "0" means that the actual motor speed is different from the speed reference set. This can be the case i.e. while the speed is ramped up/down during

start/stop. Bit 08 = "1" means that the present motor speed equals the speed reference set.

Bit 09, Local operation / bus control:

Bit 09 = "0" means that [STOP/RESET] is activated on the control unit, or that *Local control* in parameter 002 *Local/remote operation* is selected. It is not possible to control the frequency converter via serial communication. Bit 09 = "1" means that it is possible to control the frequency converter via serial communication.

Bit 10, Out of range/frequency:

Bit 10 = "0", if the output frequency has reached the value in parameter 201 *Output frequency low limit* or parameter 202 *Output frequency high limit*. Bit 10 = "1" means that the output frequency is within the defined limits.

Bit 11, Not running / running:

Bit 11 = "0" means that the motor is not running. Bit 11 = "1" means that the FC motor has a start signal or that the output frequency is greater than 0 Hz.

Bit 13, Voltage OK / above limit:

Bit 13 = "0" means that the voltage limits of the FC motor have not been exceeded. Bit 13 = "1" means that the DC voltage of the FC motor intermediate circuit is too low or too high.

Bit 14, Current OK / above limit:

Bit 14 = "0" means that the motor current is lower than the torque limit selected in parameter 221. Bit 14 = "1" means that the torque limit in parameter 221 has been exceeded.

Bit 15, Thermal warning:

Bit 15 = "0" means that the timers for motor thermal protection and VLT thermal protection, respectively, have not exceeded 100%. Bit 15 = "1" means that one of the timers has exceeded 100%.

Bus reference value:

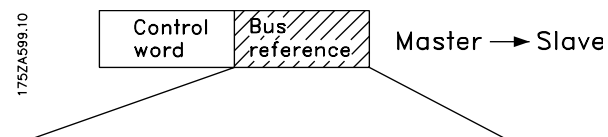

15 14 13 12 11 10 9 8 7 6 5 4 3 2 1 0 Bit no.
The frequency reference value is transmitted to the frequency converter in the form of a 16-bit word. The value is transmitted as a whole number (0-32767). 16384 (4000 Hex) corresponds to 100%. (Negative figures are formed by means of 2's complement.)

The bus reference has the following format:

Parameter 203 = "0"

"ref_{MIN}-ref_{MAX}"

0-16384 (4000 Hex) ~ 0-100% ~ ref_{MIN} - ref_{MAX}

Parameter 203 = "1"

-ref_{MAX} - +ref_{MAX}

-16384 (. . . Hex) - +16384 (4000 Hex) ~

-100- +100% ~ -ref_{MAX}- +ref_{MAX}

Actual output frequency

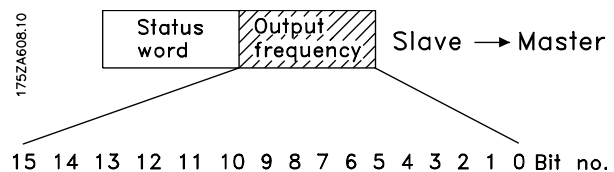

15 14 13 12 11 10 9 8 7 6 5 4 3 2 1 0 Bit no.
The value of the actual output frequency of the frequency converter is transmitted in the form of a 16-bit word. The value is transmitted as a whole number (0-32767). 16384 (4000 Hex) corresponds to 100%. (Negative figures are formed by means of 2's complement).

■ Galvanic isolation (PELV)

PELV offers protection by way of extra low voltage. Protection against electric shock is considered to be ensured when all connected devices are of the PELV type and the installation is made as described in local/national regulations on PELV supplies.

In FCM 300 Series all control terminals are supplied from or in connection with extra low voltage (PELV).

Galvanic (ensured) isolation is obtained by fulfilling requirements concerning higher isolation and by providing the relevant creepage/clearance distances. These requirements are described in the EN 50178 standard.

The components that make up the electrical isolation, as described below, also comply with the requirements concerning higher isolation and the relevant test as described in EN 50178.

The galvanic isolation can be shown in three locations (see drawing below), namely:

1. Power supply (SMPS) incl. signal isolation of U_{DC} , indicating the intermediate current voltage.
2. Gate drive that runs the IGBTs (optocouplers).
3. Current transducers (opto-couplers).

■ Earth leakage current

Earth leakage current is primarily caused by the capacitance between motor phases and the motor frame. The RFI filter contributes additional leakage current, as the filter circuit is connected to earth through capacitors.

The size of the leakage current to the ground depends on the following factors, in order of priority:

1. Switching frequency

2. Motor grounded on site or not

The leakage current is of importance to safety during handling/operation of the frequency converter if (by mistake) the frequency converter has not been earthed.



NB!

FCM 305-375 all have leakage currents > 3.5 mA, approx 4 to 20 mA. Varies with switching frequencies within the given interval.

This means reinforced earthing must be established, if EN50178 is to be complied with.

Never use ELCB (Earth Leakage Circuit Breaker) relays also called RCD(Residual Current Device) that are not suitable for DC fault currents (type A).

If a RCD is used it must be:

- Suitable for protecting equipment with a DC current content in the fault current (3-phase rectifier)
- Suitable for power-up with short charging current to earth
- Suitable for a high leakage current.

This means it is possible to operate the FCM 300 on RCD type B:

Residual Current Devices (RCD) type B has a tolerance on trip level. It is therefore recommended to use a RCD where the max leakage current for the FCM (see above, 20 mA) is less than 1/3 of the trip level for the RCD. This means the trip level for the RCD will have to be 60 mA or higher, i.e. a RCD type B with a trip level 100 mA can be used for protection.

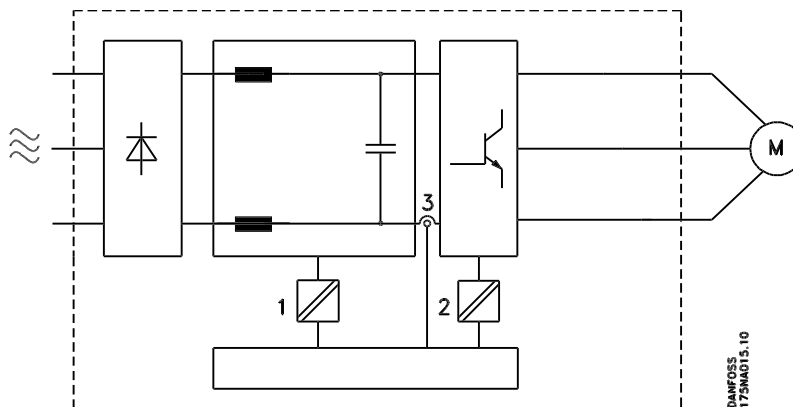

Galvanic isolation

DANFOSS
175MA015.10

■ Extreme running conditions
Motor-generated overvoltage

The voltage in the intermediate circuit is increased when the motor acts as a generator. This occurs in two cases:

1. The load drives the motor (at constant output frequency from the frequency converter), i.e. the load generates energy.
2. During deceleration ("ramp-down") if the moment of inertia is high, the load is low and the ramp-down time is too short for the energy to be dissipated as a loss in the VLT frequency converter, the motor and the installation.

The control unit attempts to correct the ramp if possible.

The inverter turns off to protect the transistors and the intermediate circuit capacitors when a certain voltage level is reached.

Mains drop-out

During a mains drop-out, FCM 300 Series continues until the intermediate circuit voltage drops below the minimum stop level, which is typically 15% below FCM 300 Series's lowest rated supply voltage.

The time before the inverter stops depends on the mains voltage before the drop-out and on the motor load.

Static overload

When FCM 300 Series is overloaded (the current limit in parameter 221 has been reached), the controls will reduce the output frequency in an attempt to reduce the load.

If the overload is excessive, a current may occur that makes the FC motor cut out after approx. 1.5 sec.

■ Acoustic noise

Below are the typical values measured at a distance of 1 m from the unit at full load:

| | 2 pole | 4 pole |
|---------|----------|----------|
| FCM 305 | | 54 dB(A) |
| FCM 311 | | 58 dB(A) |
| FCM 315 | | 59 dB(A) |
| FCM 322 | | 58 dB(A) |
| FCM 330 | | 61 dB(A) |
| FCM 340 | 62 dB(A) | 63 dB(A) |
| FCM 355 | 64 dB(A) | 60 dB(A) |
| FCM 375 | | 61 dB(A) |

■ Balance

The FCM 300 is balanced to class R according to ISO8821 (reduced balance). For critical applications

especially at high speed (>4000 RPM) special balance (class S) might be required.

■ Thermal Protection and Derating

The FCM 300 Series motor is thermally protected in case limits are exceeded. At high temperatures the switching frequency will be gradually reduced down to 2 kHz and eventually the motor will trip.



NB!

Combination of high switching frequency and missing fan cooling might damage the unit.

■ Derating for ambient temperature

The ambient temperature ($T_{AMB,MAX}$) is the maximum temperature allowed. The average ($T_{AMB,AVG}$) measured over 24 hours must be at least 5°C lower.

If FCM 300 Series is operated at temperatures above 40 °C, a derating of the continuous output current is necessary.

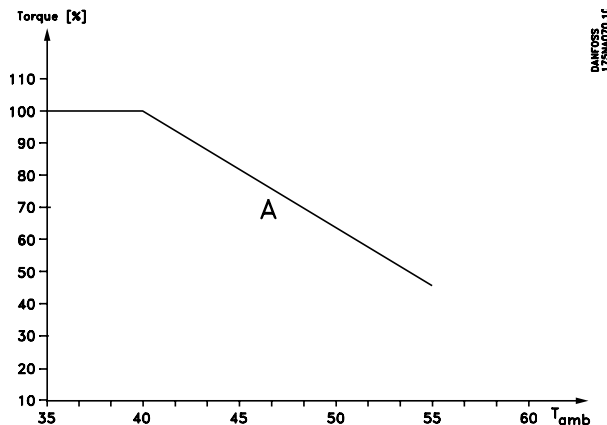

■ Derating for air pressure

By altitudes above 2 km, please contact Danfoss Drives regarding PELV.

Below 1000 m altitude no derating is necessary.

Above 1000 m the ambient temperature (T_{AMB}) or max. output current ($I_{VLT,MAX}$) must be derated in accordance with the following diagram:

1. Derating of output current versus altitude at $T_{AMB} = \text{max. } 40^{\circ}\text{C}$

2. Derating of max. T_{AMB} versus altitude at 100% output current.

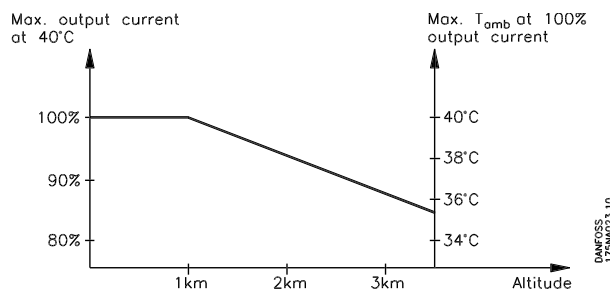

■ Derating for running at low speed

When a centrifugal pump or a fan is controlled by a FC motor, it is not necessary to reduce the output at low speed because the load characteristic of the centrifugal pumps/fans, automatically ensures the necessary reduction.

FC motors running constant load torque applications continuously at low speed must be derated (see diagram) or an independent fan must be used (motor cooling method 2).

Nominal torque (100%) can be yielded up to 15 min and at a duty cycle up to 25% at low speed.

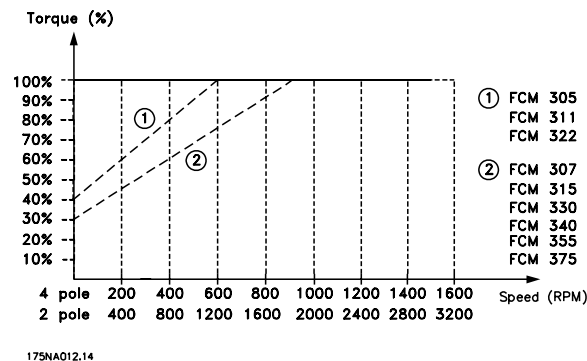

■ Derating for high switching frequency

The FCM 300 Series motor can use two different PWM schemes, SFAVM and 60° AVM. Factory setting is

All about FCM 300

SFAVM. The PWM scheme can be changed in parameter 446. Below 25 Hz motor speed the FCM 300 Series motor automatically change to SFAVM.

Factory setting of the switching frequency is 4000 Hz. It can be changed between 2 and 14 kHz in parameter 411.

A higher switching frequency leads to a quieter running unit but higher losses in the electronics of the FC motor and makes an appropriate derating necessary.

See below Torque characteristic

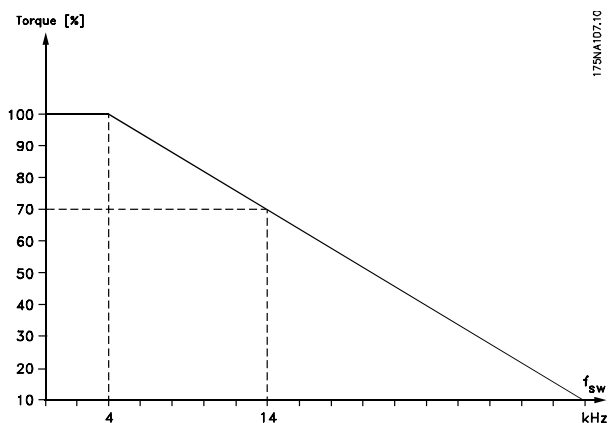

■ Vibration and shock

FCM 300 Series has been tested according to a procedure based on the following standards:

- IEC 60068-2-6: Vibration (sinusoidal) - 1970
- IEC 60068-2-34: Random vibration broad-band
- general requirements
- IEC 60068-2-35: Random vibration broad-band
- high reproducibility
- IEC 60068-2-36: Random vibration broad-band
- medium reproducibility

FCM 300 Series complies with requirements that correspond to conditions in the standards mentioned above.

■ Air humidity

FCM 300 Series has been designed to meet the IEC 60068-2-3 standard, EN 50178 item 9.4.2.2/DIN 40040, class E, at 40°C.

Cyclic damp heat according to IEC 60068-2-30, 40°C.

■ UL standard

FCM 300 Series is UL approved.

See *Technical data* for correct use of prefuses.

Efficiency

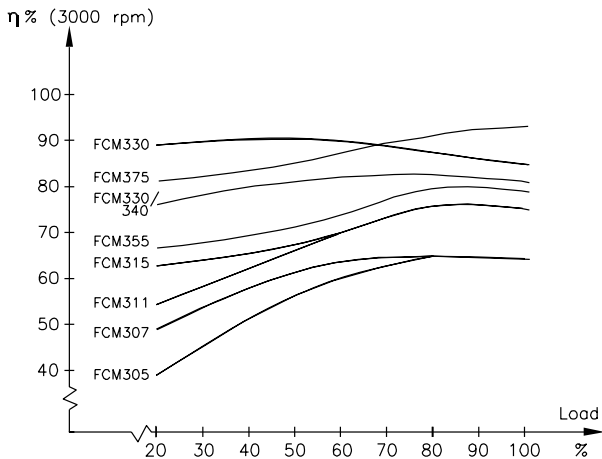

175NA064.11

2 pole

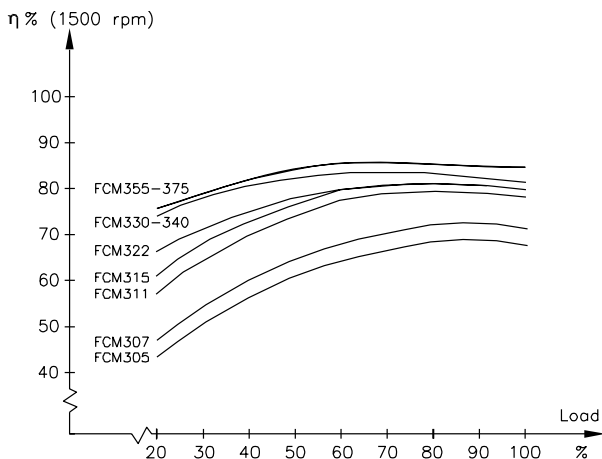

175NA016.14

4 pole

Mains supply interference/harmonics

A FC motor takes up a non-sinusoidal current from mains, which increases the input current I_{RMS} . A non-sinusoidal current can be transformed by means of a Fourier analysis and split up into sine wave currents with different frequencies, i.e. different harmonic currents I_N with 50 Hz as the basic frequency:

| Harmonic currents | I_1 | I_5 | I_7 | I_{11} |
|-------------------|-------|--------|--------|----------|
| Hz | 50 Hz | 250 Hz | 350 Hz | 550 Hz |
| I_n/I_1 [%] | 100% | 44% | 29% | 8% |

The harmonics do not affect the power consumption directly, but increase the heat losses in the installation (transformer, cables). Consequently, in plants with a rather high percentage of rectifier load, it is important to maintain harmonic currents at a low level to avoid overload of the transformer and high temperature in the cables.

Some of the harmonic currents might disturb communication equipment connected to the same transform-

er or cause resonance in connection with power-factor correction batteries.

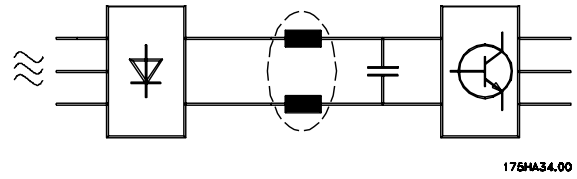

To ensure low, harmonic currents, FCM 300 has intermediate circuit coils as standard.. THD (current) $\leq 54\%$

The voltage distortion on the mains supply depends on the size of the harmonic currents multiplied by the mains impedance for the frequency in question. The total voltage distortion THD is calculated on the basis of the individual voltage harmonics using the following formula:

$$THD = \frac{U_1}{\sqrt{U_2^2 + \dots + U_n^2}} (\%)$$

Power factor

The power factor is the relation between I_1 and I_{RMS} .

The power factor for 3-phase control

$$= \frac{\sqrt{3 \times U \times I_1 \times \cos \varphi_1}}{\sqrt{3 \times U \times I_{RMS}}}$$

$$\text{Power factor} = \frac{I_1 \times \cos \varphi_1}{I_{RMS}} = \frac{I_1}{I_{RMS}} \approx 0.9 \text{ since } \cos \varphi = 1$$

The power factor indicates the extent to which the FC motor imposes a load on the mains supply.

The lower the power factor, the higher the I_{RMS} for the same kW performance.

In addition, a high power factor indicates that the different harmonic currents are low.

$$I_{RMS} = \sqrt{I_1^2 + I_5^2 + I_7^2 + \dots + I_n^2}$$

What is CE labelling?

The purpose of CE labelling is to avoid technical obstacles to trade within EFTA and the EU. The EU has introduced the CE label as a simple way of showing whether a product complies with the relevant EU directives. The CE label says nothing about the specifications or quality of the product. Frequency converters are regulated by three EU directives:

The machinery directive(98/37/EEC)

All machines with critical moving parts are covered by the machinery directive, which came into force on 1 January 1995. Since a frequency converter is largely electrical, and the motor always will be placed in connection with other machines, it does not fall under the machinery directive. However, if a FC motor is sup-

plied for use in a machine, we provide information on safety aspects relating to the FC motor. We do this by means of a manufacturer's declaration.

■ **The low-voltage directive (73/23/EEC)**

Frequency converters must be CE labelled in accordance with the low-voltage directive. The directive applies to all electrical equipment and appliances used in the voltage range of 50-1000 V AC and 75-1500 V DC.

■ **The EMC directive(89/336/EEC)**

EMC is short for electromagnetic compatibility. The presence of electromagnetic compatibility means that the mutual interference between different components/ appliances is so small that the functioning of the appliances is not affected. The EMC directive came into force on 1 January 1996. The directive distinguishes between components, appliances, SYSTEMS and installations.

■ **What is covered?**

The EU "Guidelines on the Application of Council Directive 89/336/EEC" outline three typical situations of using a FC motor. For each of these situations, explanations are offered as to whether the situation in question is covered by the EMC directive and must be CE labelled.

1. The FC motor is sold directly to the endconsumer. The FC motor is for example sold to a DIY market. The end-consumer is a layman. He installs the FC motor himself for use with a hobby machine, a kitchen appliance, etc. For such applications, the FC motor must be CE labelled in accordance with the EMC directive.
2. The FC motor is sold for installation in a plant. The plant is built up by professionals of the trade. It could be a production plant or a heating/ ventilation plant designed and installed by professionals of the trade. Neither the FC motor nor the finished plant has to be CE labelled under the EMC directive. However, the unit must comply with the basic EMC requirements of the directive. The installer can ensure this by using components, appliances and SYSTEMS that are CE labelled under the EMC directive.
3. The FC motor is sold as part of a complete SYSTEM. The SYSTEM is being marketed as complete. It could be e.g. an air-conditioning SYSTEM. The complete SYSTEM must be CE labelled in accordance with the EMC

directive. The manufacturer who supplies the SYSTEM can ensure CE labelling under the EMC directive either by using CE labelled components or by testing the EMC of the SYSTEM. If he chooses to use only CE labelled components, he does not have to test the entire SYSTEM.

■ **Danfoss FCM 300 Series motor and CE labelling**

CE labelling is a positive feature when used for its original purpose, i.e. to facilitate trade within the EU and EFTA.

However, CE labelling may cover many different specifications. This means that it has to be checked what a given CE label specifically covers.

The specifications covered can in fact be widely different. That is why a CE label can give the installer a false feeling of security when using a FC motor as a component in a SYSTEM or an appliance.

We CE label our VLT® DriveMotors in accordance with the low-voltage directive. This means that as long as the FC motor is installed correctly, we guarantee that it complies with the low-voltage directive. We issue a declaration of conformity that confirms our CE labelling in accordance with the low-voltage directive.

The CE label also applies to the EMC directive, on condition that the instructions given in the Operating Instructions for EMC-correct installation and filtering have been followed. On this basis, a declaration of conformity in accordance with the EMC directive is issued.

The Quick Guide gives detailed instructions for installation to ensure that your installation is EMCcorrect. Furthermore, we specify which norms that are complied with by our different products.

We offer the filters that can be seen from the specifications and gladly provide other types of assistance that can help you obtain the best EMC result.

■ **Compliance with EMC directive 89/336/EEC**

In the great majority of cases, the VLT DriveMotor is used by professionals of the trade as a complex component forming part of a larger appliance, SYSTEM or installation. It must be noted that the responsibility for the final EMC properties of the appliance, SYSTEM or installation rests with the installer. As an aid to the installer, Danfoss has prepared EMC installation guidelines for the Power Drive System. The standards and test levels stated for Power Drive Systems are complied with, provided the right EMC-correct instructions for installation have been followed, see electrical installation.

■ EMC standards



NB!

- All EMC specifications are stated with factory settings.
- Maximum 4 kHz switching frequency.
- Screened data/control cables must be used for surge protection.
- The FC motor must be connected to earth in order to comply.
- Maximum/minimum line impedance $Z_{max} = 0.24 + j0.15 \text{ ohm}$; $Z_{min} = 0 + j0 \text{ ohm}$. (EN 61800-3 commutation notches)

Generic standards

The generic standards are stated in the EMC directive (89/336/EEC).

The FC motor complies with:

EN 61000-6-3¹⁾, EN 61000-6-1.

Residential, commercial and light industrial environment.

EN 61000-6-2, EN 61000-6-4.

Industrial environment.

¹⁾Emission levels stated by EN 61000-6-3 are only fulfilled by FC motors with class B-1 optional filter.

Furthermore the FC motor complies with: DIN VDE 0160/1990 ²⁾

²⁾'Protection against overvoltage 7.3.1. class1'

Product standards

The product standards are stated in EN 61800-3 (IEC 61800-3).

The FC motor complies with:

EN 61800-3, unrestricted distribution³⁾.

EN 61800-3, restricted distribution.

³⁾ Emission levels stated by EN 61800-3 unrestricted distribution are only fulfilled by FC motors with class B-1 filter.

Basic standards, emissions

- *EN 55011*: Limits and methods of measuring radio disturbance characteristics of industrial, scientific and medical (ISM) radio-frequency equipment.

- *EN 55022*: Limits and methods of measuring radio disturbance characteristics of information technology equipment.
- *EN 61000-3-2*: Limits for harmonic current emissions (equipment input current • 16 A)
- *EN 61000-3-4*: Limits for harmonic current emissions (equipment input current • 16 A)

Basic standards, immunity

- *EN 61000-2-4 (IEC 61000-2-4)*: Compatibility levels
Simulation of voltage and frequency fluctuations, harmonics and commutation notches on the power line.
- *EN 61000-4-2 (IEC 61000-4-2)*: Electrostatic discharge (ESD)
Simulation of electrostatic discharge.
- *EN 61000-4-4 (IEC 61000-4-4)*: Fast transients, burst 5/ 50 nS
Simulation of transients caused by switching of contactors, relays or similar devices.
- *EN 61000-4-5 (IEC 61000-4-5)*: Surges 1.2/ 50 µS.
Simulation of transients caused by e.g. lightning that strikes near an installation.
- *EN 61000-4-3 (IEC 61000-4-3)*: Radio-frequency electromagnetic field. Amplitude modulated.
Simulation of interference caused by radio transmission equipment.
- *EN 61000-4-6 (IEC 61000-4-6)*: RF common mode.
Simulation of the effect from radio-transmitting equipment connected to connection cables.
- *ENV 50204*: Radio-frequency electromagnetic field. Pulse modulated.
Simulation of interference caused by GSM mobile phones.

General aspects of EMC emissions

For high frequency shielding, screened cables used for Profibus, standard bus, control cables and signal interface must in general be connected to the enclosure at both ends.

General aspects of EMC immunity

If there are problems with low frequency interference (ground loops), screened cable used for Profibus, standard bus, control cables and signal interface can be left open at one end.

■ Aggressive environments

In common with all electronic equipment, a VLT frequency converter contains a large number of mechanical and electronic components, all of which are vulnerable to environmental effects to some extent.



The VLT frequency converter should not therefore be installed in environments with airborne liquids, particles or gases capable of affecting and damaging the electronic components. Failure to take the necessary protective measures increases the risk of stoppages, thus reducing the life of the VLT frequency converter.

Liquids can be carried through the air and condense in the VLT frequency converter. In addition to this, liquids may cause corrosion of components and metal parts.

Steam, oil and salt water may cause corrosion of components and metal parts.

In such environments, equipment with enclosure rating \geq IP 54 is recommended.

In environments with high temperatures and humidity, corrosive gases such as sulphur, nitrogen and chlor-

ine compounds will cause chemical processes on the VLT frequency converter components. Such chemical reactions will rapidly affect and damage the electronic components.



NB!

Mounting VLT frequency converters in aggressive environments will increase the risk of stoppages and furthermore considerably reduce the life of the converter.

Before the installation of the VLT frequency converter, the ambient air should be checked for liquids, particles and gases. This may be done by observing existing installations in this environment. Typical indicators of harmful airborne liquids are water or oil on metal parts, or corrosion of metal parts.

Excessive dust particle levels are often found on installation cabinets and existing electrical installations. One indicator of aggressive airborne gases is blackening of copper rails and cable ends on existing installations.

■ List of warnings and alarms

The table gives the different warnings and alarms and indicates whether the fault locks the FC motor. After Trip locked, the mains supply must be cut and the fault must be corrected. Reconnect the mains supply and reset the FC motor before being ready. Wherever a cross is placed under both Warning and

Alarm, this can mean that a warning precedes the alarm. It can also mean that it is possible to program whether a given fault is to result in a warning or an alarm. After a trip, alarm and warning will flash, but if the fault is removed, only alarm will flash. After a reset, the FC motor will be ready to start operation again.

| No. | Description | Warning | Trip Alarm | Trip locked |
|-----|---|---------|------------|-------------|
| 2 | Live zero fault (LIVE ZERO ERROR) | X | X | |
| 4 | Phase loss (MAINS PHASE LOSS) | X | X | X |
| 5 | Voltage warning high (DC LINK VOLTAGE HIGH) | X | | |
| 6 | Voltage warning low (DC LINK VOLTAGE LOW) | X | | |
| 7 | Overvoltage (DC LINK OVERVOLT) | | X | X |
| 8 | Undervoltage (DC LINK UNDERVOLT) | | X | |
| 9 | Inverter overload (INVERTER TIME) | X | X | |
| 11 | Motor thermistor (MOTOR THERMISTOR) | | X | |
| 12 | Torque limit (TORQUE LIMIT) | X | | |
| 13 | Overcurrent (OVERCURRENT) | | X | X |
| 14 | Earth fault (EARTH FAULT) | | X | X |
| 15 | Supply fault (SWITCH MODE FAULT) | | X | X |
| 16 | Short-circuit (CURR.SHORT CIRCUIT) | | X | X |
| 17 | Standard bus timeout (STD BUS TIMEOUT) | X | X | |
| 18 | HPFB bus timeout (HPFB TIMEOUT) | X | X | |
| 33 | Out of frequency range (OUT FREQ RNG/ROT LIM) | X | | |
| 34 | HPFB error (HPFB ALARM) | X | X | |
| 35 | Inrush fault (INRUSH FAULT) | | X | X |
| 36 | Overtemperature (OVERTEMPERATURE) | X | X | |
| 37 | Internal error (INTERNAL ERROR) | | X | X |

■ What if the motor does not start?

The LCP may be set for local stop. If so, the motor does not start when you disconnect the LCP. To make the motor start a LCP has to be connected, - there is no other way, and the MCT 10 Setup Software will not tell you what is wrong or what to do. So in case of problems follow the procedure stated below:



Warning:

Extreme care must be taken when operating the unit with open lid.

| Green | Yellow | Red | Action |
|---------|---------|---------|--|
| LED 302 | LED 301 | LED 300 | |
| OFF | OFF | OFF | Apply power |
| ON | OFF | OFF | Apply start and reference signals |
| ON | OFF | ON | Apply and remove reset signal |
| ON | ON | ON | Switch off power until all LED's have turned off |

For further information see the quick setup MG.03.Fx.xx.

1. Make sure no parameters have been changed from initial delivery status (factory setting). Use the Local Control Panel or serial port to reset to factory setting. Make sure that parameter 002 is set for remote (if not, the yellow LED 301 will be flashing slowly).
 2. Make sure no STOP command has been made via the optional control panel keyboard
 3. Check the Light Emitting Diodes visible through a hole in the inside isolation cover (see drawing page 16) follow table below.
- *) as from software version 2.12
- (local stop, yellow LED 301 flashing slowly *), Control panel STOP can only be restarted by the Control Panel START button.

Serial communication problems If the bus address is set for a high value, communication may seem to be impossible, if the high address is not scanned by the master. The address is not changed back to factory setting with reset to factory setting function.

■ **Warnings**

The display flashes between normal state and warning. A warning comes up on the first and second line of the display. See examples below:



Alarm messages

The alarm comes up in the 2. and 3. line of the display, see example below:



WARNING/ALARM 2

Live zero fault (LIVE ZERO ERROR):

The current signal on terminal 1 is less than 50% of the value set in parameter 336 *Terminal 1, min. scaling*.

WARNING/ALARM 4

Phase loss (MAINS PHASE LOSS):

Phase missing on the supply side. Check the supply voltage to the FC motor.

WARNING 5

Voltage warning high (DC LINK VOLTAGE HIGH):

The intermediate circuit voltage (DC) is higher than the overvoltage limit of the control SYSTEM, see table on this page. The FC motor is still active.

WARNING 6

Voltage warning low (DC LINK VOLTAGE LOW):

The intermediate circuit voltage (DC) is below the undervoltage limit of the control SYSTEM, see table below. The FC motor is still active.

ALARM 7

Overvoltage (DC LINK OVERVOLT):

If the intermediate circuit voltage (DC) exceeds the inverter overvoltage limit (see table), the FC motor will trip. Furthermore, the voltage will be stated in the display.

ALARM 8

Undervoltage (DC LINK UNDERVOLT):

If the intermediate circuit voltage (DC) drops below the inverter lower voltage limit (see table on this page), the FC motor will trip after 3 - 28 sec., depending on unit. Furthermore, the voltage will be stated in the display. Check whether the supply voltage matches the FC motor, see technical data.

WARNING/ALARM 9

Inverter overload (INVERTER TIME):

The electronic, thermal inverter protection reports that the FC motor is about to cut out because of an overload (too high current for too long). The counter for electronic, thermal inverter protection gives a warning at 95% and trips at 100%, while giving an alarm. The FC motor cannot be reset until the counter is below 90%.

Trip/Alarm/warning limits:

| | |
|----------------------|-----------------------------|
| FC motor Series | 3 x 380 - 480 V [VDC] |
| Undervoltage | 410 |
| Voltage warning low | 440 |
| Voltage warning high | 760 |
| Overvoltage | 760* |

* 760V in 5 sec. or 800V immediately.
The voltages stated are the intermediate circuit voltage of the FC motor.

ALARM 11

Motor thermistor (MOTOR THERMISTOR):

If a thermistor is mounted and parameter 128 is set to *Enable* [1], the FC motor will trip if the motor gets too hot.

WARNING 12

Current limit (CURRENT LIMIT):

The current is higher than the value in parameter 221 (in motor operation).

ALARM 13

Overcurrent (OVERCURRENT):

The inverter peak current limit (approx. 230% of the rated current) has been exceeded. The FC motor will trip, while giving an alarm.

Turn off the FC motor and check whether the motor shaft can be turned.



NB!

If shock loads occur this alarm may appear.

ALARM: 14

Earth fault (EARTH FAULT):

There is a discharge from the output phases to earth, either between the inverter and the motor or in the motor itself.

ALARM: 15

Supply fault (SWITCH MODE FAULT):

Fault in the switch mode power supply (internal 24 V supply).

Contact your Danfoss supplier.

ALARM: 16

Short-circuiting (CURR.SHORT CIRCUIT):

There is short-circuiting on the motor terminals or the motor itself.

Contact your Danfoss supplier.

ALARM: 17

Standard bus timeout (STD BUSTIMEOUT)

There is no communication to the FC motor. The warning will only be active when parameter 514 has been set to another value than *OFF*.

If parameter 514 has been set to *stop and trip*, it will first give a warning and then ramp down until it trips, while giving an alarm.

Parameter 513 Bus time interval could possibly be increased.

WARNING/ALARM 18

HPFB bus timeout (HPFB BUS TIMEOUT)

There is no communication with the FC motor. The warning will only be active when parameter 804 has been set to another value than *OFF*. If parameter 804 has been set to *Stop and trip*, it will first give a warning and then ramp down until it trips, while giving an alarm. Parameter 803 *Bus time out* could possibly be increased.

WARNING 33

Out of frequency range:

This warning is active if the output frequency has reached parameter 201 *Output frequency low limit* or parameter 202 *Output frequency high limit*.

WARNING/ALARM 34

HPFB error (HPFB ALARM):

The profibus communication is not working correctly.

ALARM 35

Inrush fault (INRUSH FAULT):

This warning occurs when the unit has been switched on too many times within 1 minute.

WARNING/ALARM 36

Overtemperature (OVERTEMPERATURE):

ALARM: 37

Internal error (INTERNAL ERROR):

An error has occurred in the SYSTEM. Contact your Danfoss supplier.

■ Warning word, extended Status word and Alarm word

Warning word, extended status word and alarm word are shown on the display in Hex format. If there are more than one warning or alarm, a sum of all warnings or alarms will be shown.

Warning word, extended status word and alarm word can also be displayed using the serial bus in parameter 540, 541 and 538.

| Bit (Hex) | Warning word (P. 540) |
|------------------|------------------------------|
| 00000008 | HPFB timeout |
| 00000010 | Standard bus timeout |
| 00000040 | Current limit |
| 00000200 | Inverter overload |
| 00001000 | Voltage warning low |
| 00002000 | Voltage warning high |
| 00004000 | Phase loss |
| 00010000 | Live zero error warning |
| 00400000 | Output freq. limit warning |
| 00800000 | HPFB error |
| 40000000 | 24 V supply warning |
| 80000000 | Inverter temp. high |

| Bit (Hex) | Extended status word (P.541) |
|------------------|-------------------------------------|
| 01 | Ramping |
| 04 | Start clockwise/counterclockwise |
| 08 | Slow down |
| 10 | Catch-up |
| 8000 | Frequency limit |

| Bit (Hex) | Alarm word (P.538) |
|------------------|---------------------------|
| 00000002 | Trip lock |
| 00000040 | HPFB timeout |
| 00000080 | Standard bus timeout |
| 00000100 | Short circuit |
| 00000200 | 24 V supply fault |
| 00000400 | Earth fault |
| 00000800 | Overcurrent |
| 00004000 | Motor thermistor |
| 00008000 | Inverter overload |
| 00010000 | Undervoltage |
| 00020000 | Overvoltage |
| 00040000 | Phase loss |
| 00080000 | Live zero error |
| 00100000 | Overtemperature |
| 02000000 | HPFB error |
| 08000000 | Inrush fault |
| 10000000 | Internal error |

■ List of parameters

Functions to programme, to control, and to monitor via bus (PROFIBUS) or by PC.

| Parameter No. | Function | Range/number of settings/value | Factory setting | Data type | Conv. index |
|---------------|---------------------------------------|--------------------------------|------------------------------|-----------|-------------|
| 001 | Language | 6 | English | 5 | 0 |
| 002 | Local/remote control | 2 | Remote control | 5 | 0 |
| 003 | Local reference | | 000.000 | 4 | -3 |
| 004 | Active Setup | 4 | Setup 1 | 5 | 0 |
| 005 | Programming Setup | 4 | Active setup | 5 | 0 |
| 006 | Copying of Setups | 4 | No copying | 5 | 0 |
| 007 | LCP copy | 4 | No copying | 5 | 0 |
| 008 | Display scaling of motor frequency | | 100 | 6 | -2 |
| 009 | Display line 2 | 24 | Frequency [Hz] | 5 | 0 |
| 010 | Display line 1.1 | 24 | Reference [%] | 5 | 0 |
| 011 | Display line 1.2 | 24 | Motor current [A] | 5 | 0 |
| 012 | Display line 1.3 | 24 | Power [kW] | 5 | 0 |
| 013 | Local control/configuration | 5 | LCP digital control/par. 100 | 5 | 0 |
| 014 | Local stop | 2 | Possible | 5 | 0 |
| 015 | Local jog | 2 | Not possible | 5 | 0 |
| 016 | Local reversing | 2 | Not possible | 5 | 0 |
| 017 | Local reset of trip | 2 | Possible | 5 | 0 |
| 018 | Lock for data change | 2 | Not locked | 5 | 0 |
| 019 | Operating state at power up, local c. | 3 | Forced stop, use saved ref. | 5 | 0 |
| 100 | Configuration | 2 | Speed, open loop mode | 5 | 0 |
| 101 | Torque characteristics | 4 | Constant torque | 5 | 0 |
| 102 | Motor power | XX.XX kW - dep. on unit | | 6 | 1 |
| 103 | Motor voltage | XX.XX V - dep. on unit | | 6 | 0 |
| 104 | Motor frequency | XX.X Hz - dep. on unit | | 6 | -1 |
| 105 | Motor current | XX.XX A - dep. on unit | | 7 | -2 |
| 106 | Rated motor speed | XX rpm - dep. on unit | | 6 | 0 |
| 117 | Resonance damping | off - 100% | off % | 6 | 0 |
| 126 | DC braking time | 0.0 (off) - 60.0 sec. | 10.0 sec. | 6 | -1 |
| 127 | DC brake cut-in frequency | 0.0 Hz - f _{MAX} | 0.0 Hz | 6 | -1 |
| 128 | Motor thermal protection | 1 | No protection | 5 | 0 |
| 132 | DC braking voltage | 0 - 100 % | 0 % | 5 | 0 |
| 133 | Start voltage | 0.00 - 100.00 V | Motor dependent | 6 | -2 |
| 134 | Start compensation | 0.0 - 300.0 % | 100.0 % | 6 | -1 |
| 135 | U/f ratio | 0.00 - 20.00 V/Hz | Motor dependent | 6 | -2 |
| 136 | Slip compensation | -500.0 - +500.0 % | 100.0 % | 3 | -1 |
| 137 | DC holding voltage | 0 - 100 % | 0 % | 5 | 0 |
| 138 | Brake cut out frequency | 0.5 - 132 Hz | 3.0 Hz | 6 | -1 |
| 139 | Brake cut in frequency | 0.5 - 132 Hz | 3.0 Hz | 6 | -1 |

Conversion index:

This number refers to a conversion figure to be used when writing or reading via serial communication with a frequency converter.

See *Databytes* in *Serial Bus*.

Data type:

Data type shows the type and length of the telegram.

| Data type | Description |
|-----------|-------------|
| 3 | Integer 16 |
| 4 | Integer 32 |
| 5 | Unsigned 8 |
| 6 | Unsigned 16 |
| 7 | Unsigned 32 |
| 9 | Text string |

VLT® FCM Series

Functions to programme, to control, and to monitor via bus (PROFIBUS) or by PC.

| Parameter No. | Function | Range/number of settings/value | Factory setting | Data type | Conv. index |
|---------------|-------------------------------------|--------------------------------------|---------------------------|-----------|-------------|
| 200 | Rotation direction | 3 | Only clockwise 0 - 132 Hz | 5 | 0 |
| 201 | Min. output frequency (f_{MIN}) | 0.0 Hz - f_{MAX} | 0.0 Hz | 6 | -1 |
| 202 | Max. output frequency (f_{MAX}) | f_{MIN} - f_{RANGE} | f_{RANGE} (132 Hz) | 6 | -1 |
| 203 | Reference/feedback range | Min. - max./-max. - +max. | Min. - Max. | 5 | 0 |
| 204 | Minimum reference | -100,000.000 - Ref_{MAX} | 0.000 | 4 | -3 |
| 205 | Maximum reference | Ref_{MIN} - 100,000.000 | 50.000 | 4 | -3 |
| 207 | Ramp-up time 1 | 0.05 - 3600.00 sec. | 3.00 sec. | 7 | -2 |
| 208 | Ramp-down time 1 | 0.05 - 3600.00 sec. | 3.00 sec. | 7 | -2 |
| 209 | Ramp-up time 2 | 0.15 - 3600.00 sec. | 3.00 sec. | 7 | -2 |
| 210 | Ramp-down time 2 | 0.15 - 3600.00 sec. | 3.00 sec. | 7 | -2 |
| 211 | Jog ramp time | 0.05 - 3600.00 sec. | 3.00 sec. | 7 | -2 |
| 212 | Quick stop ramp-down time | 0.05 - 3600.00 sec. | 3.00 sec. | 7 | -2 |
| 213 | Jog frequency | 0 Hz - f_{MAX} | 10.0 Hz | 6 | -1 |
| 214 | Reference function | 2 | Sum | 5 | 0 |
| 215 | Preset reference 1 | -100.00 % - +100.00 % | 0.00 % | 3 | -2 |
| 216 | Preset reference 2 | -100.00 % - +100.00 % | 0.00 % | 3 | -2 |
| 219 | Catch up/slow down value | 0.00 - 100.00 % | 0.00 % | 6 | -2 |
| 221 | Current limit for motor mode | Min.- max. limit in % of I_{rated} | Max. limit | 6 | -1 |
| 229 | Frequency bypass bandwidth | bypass, 0 (off) - 100 % | 0 % | 6 | 0 |
| 230 | Frequency bypass 1 | 0.0 - 132 Hz | 0.0 Hz | 6 | -1 |
| 231 | Frequency bypass 2 | 0.0 - 132 Hz | 0.0 Hz | 6 | -1 |
| 241 | Reference preset 1 | -100.00 % - +100.00 % | 0.00 % | 3 | -2 |
| 242 | Reference preset 2 | -100.00 % - +100.00 % | 0.00 % | 3 | -2 |
| 243 | Reference preset 3 | -100.00 % - +100.00 % | 0.00 % | 3 | -2 |
| 244 | Reference preset 4 | -100.00 % - +100.00 % | 0.00 % | 3 | -2 |
| 245 | Reference preset 5 | -100.00 % - +100.00 % | 0.00 % | 3 | -2 |
| 246 | Reference preset 6 | -100.00 % - +100.00 % | 0.00 % | 3 | -2 |
| 247 | Reference preset 7 | -100.00 % - +100.00 % | 0.00 % | 3 | -2 |

Functions to programme, to control, and to monitor via bus (PROFIBUS) or by PC.

| Parameter No. | Function | Range/number of settings/value | Factory setting | Data type | Conv. index |
|---------------|--------------------------------------|--------------------------------|-----------------|-----------|-------------|
| 317 | Time out | 1 - 99 sec. | 10 sec. | 5 | 0 |
| 318 | Function after time out | Off/Stop and trip | Off | 5 | 0 |
| 323 | X102 relay function | 14 | No operation | 5 | 0 |
| 327 | Pulse reference/feedback, max. freq. | 100 - 70000 Hz | 5000 Hz | 7 | 0 |
| 331 | Terminal 1, analog input current | 3 | No operation | 6 | 0 |
| 332 | Terminal 2, digital input | 31 | Reference | 6 | 0 |
| 333 | Terminal 3, digital input | 31 | Reset | 6 | 0 |
| 334 | Terminal 4, digital input | 30 | Start | 6 | 0 |
| 335 | Terminal 5, digital input | 29 | Jog | 6 | 0 |
| 336 | Terminal 1, min. scaling | 0.0 - 20.0 mA | 0.0 mA | 6 | -4 |
| 337 | Terminal 1, max. scaling | 0.0 - 20.0 mA | 20.0 mA | 6 | -4 |
| 338 | Terminal 2, min. scaling | 0.0 - 10.0 V | 0.0 V | 6 | -1 |
| 339 | Terminal 2, max. scaling | 0.0 - 10.0 V | 10.0 V | 6 | -1 |
| 340 | Output functions | 24 | No operation | 6 | 0 |

VLT® FCM Series

Functions to programme, to control, and to monitor via bus (PROFIBUS) or by PC.

| Parameter No. | Function | Range/number of settings/ value | Factory setting | Data type | Conv. index |
|---------------|-----------------------------------|------------------------------------|----------------------|-----------|-------------|
| 400 | Brake function | Off/AC braking | Off | 5 | 0 |
| 403 | Sleep mode timer | 0-300 sec. | Off | 6 | 0 |
| 404 | Sleep frequency | f_{MIN} - par 407 | 0 Hz | 6 | -1 |
| 405 | Reset function | 11 | Manual reset | 5 | 0 |
| 406 | Boost setpoint | 1-200 % | 100 % | 6 | 0 |
| 407 | Wake up frequency | Par 404 - f_{MAX} | 50 Hz | 6 | -1 |
| 411 | Switching frequency | 1.5 - 14.0 kHz | Unit dependent | 6 | 0 |
| 412 | Variable switching frequency | 3 | Temp. dep. sw. freq. | 5 | 0 |
| 413 | Overmodulation function | Off/On | On | 5 | 0 |
| 414 | Minimum feedback | -100000 - FB_{HIGH} | 0 | 4 | -3 |
| 415 | Maximum feedback | FB_{LOW} - 100,000 | 1500 | 4 | -3 |
| 416 | Reference/feedback unit | 42 | % | 5 | 0 |
| 437 | Process PID normal/inverse ctrl. | Normal/inverse | Normal | 5 | 0 |
| 438 | Process PID anti windup | Disable/Enable | Enable | 5 | 0 |
| 439 | Process PID start frequency | f_{MIN} - f_{MAX} | f_{MIN} | 6 | -1 |
| 440 | Process PID proportional gain | 0.00 (off) - 10.00 | 0.01 | 6 | -2 |
| 441 | Process PID integral time | 0.01 - 9999 sec. (off) | 9999 sec. | 7 | -2 |
| 442 | Process PID differentiation time | 0.00 (off) - 10.00 sec. | 0.00 sec. | 6 | -2 |
| 443 | Process PID different. gain limit | 5 -50 | 5 | 6 | -1 |
| 444 | Process PID lowpass filter time | 0.1 - 10.00 sec. | 0.1 sec. | 6 | -2 |
| 445 | Flying start | 4 | Disable | 5 | 0 |
| 446 | Switching pattern | 2 | SFAVM | 5 | 0 |
| 461 | Feedback conversion | Linear or square root | Linear | 5 | 0 |

Conversion index:

This number refers to a conversion figure to be used when writing or reading via serial communication with a frequency converter.

See *Databytes* in *Serial Bus*.

Data type:

Data type shows the type and length of the telegram.

| Data type | Description |
|-----------|-------------|
| 3 | Integer 16 |
| 4 | Integer 32 |
| 5 | Unsigned 8 |
| 6 | Unsigned 16 |
| 7 | Unsigned 32 |
| 9 | Text string |

VLT® FCM Series

Functions to programme, to control, and to monitor via bus (PROFIBUS) or by PC.

| Parameter No. | Function | Range/number of settings/value | Factory setting | Data type | Conv. index |
|---------------|---|--------------------------------|-----------------|-----------|-------------|
| 500 | Bus address | 1 - 126 | 1 | 5 | 0 |
| 501 | Baudrate | 300 - 9600 Baud/6 | 9600 Baud | 5 | 0 |
| 502 | Coasting | 4 | Logic or | 5 | 0 |
| 503 | Quick-stop | 4 | Logic or | 5 | 0 |
| 504 | DC-brake | 4 | Logic or | 5 | 0 |
| 505 | Start | 4 | Logic or | 5 | 0 |
| 506 | Reversing | 4 | Logic or | 5 | 0 |
| 507 | Selection of setup | 4 | Logic or | 5 | 0 |
| 508 | Selection of speed | 4 | Logic or | 5 | 0 |
| 509 | Bus jog 1 | 0.0 - f_{MAX} | 10.0 Hz | 6 | -1 |
| 510 | Bus jog 2 | 0.0 - f_{MAX} | 10.0 Hz | 6 | -1 |
| 512 | Telegram profile | Profidrive/FC Drive | FC Drive | 5 | 0 |
| 513 | Bus time interval | | 1 sec. | 5 | 0 |
| 514 | Bus time interval function | 6 | Off | 5 | 0 |
| 515 | Data read-out: Reference | XXX.X | | 3 | -1 |
| 516 | Data read-out: Refer. unit | Hz/rpm | | 4 | -3 |
| 517 | Data read-out: Feedback | | | 4 | -3 |
| 518 | Data read-out: Frequency | Hz | | 3 | -1 |
| 519 | Data read-out: Frequency x scale | Hz | | 7 | -2 |
| 520 | Data read-out: Current | A x 100 | | 7 | -2 |
| 521 | Data read-out: Torque | % | | 3 | -1 |
| 522 | Data read-out: Power | kW | | 7 | 1 |
| 523 | Data read-out: Power | hp | | 7 | -2 |
| 524 | Data read-out: Motor voltage | V | | 6 | -1 |
| 525 | Data read-out: DC link voltage | V | | 6 | 0 |
| 527 | Data read-out: FC therm. | 0 - 100 % | | 5 | 0 |
| 528 | Data read-out: Digital input | | | 5 | 0 |
| 533 | Data read-out: External reference | -200.0 - +200.0 % | | 6 | -1 |
| 534 | Data read-out: Status word, binary | | | 6 | 0 |
| 537 | Data read-out: FC temperature | °C | | 5 | 0 |
| 538 | Data read-out: Alarm word, binary | | | 7 | 0 |
| 539 | Data read-out: Control word, binary | | | 6 | 0 |
| 540 | Data read-out: Warning word, 1 | | | 7 | 0 |
| 541 | Data read-out: Warning word, 2 | | | 7 | 0 |
| 542 | Data read-out: Terminal 1, analog input | mA X 10 | | 5 | -4 |
| 543 | Data read-out: Terminal 2, analog input | V X 10 | | 5 | -1 |

Functions to programme, to control, and to monitor via bus (PROFIBUS) or by PC.

| Parameter No. | Function | Range/number of settings/value | Factory setting | Data type | Conv. index |
|---------------|--|--------------------------------|-----------------|-----------|-------------|
| 600 | Operating data: Operating hours | 0 - 130,000.0 hours | | 5 | 0 |
| 601 | Operating data: Hours run | 0 - 130,000.0 hours | | 7 | 73 |
| 603 | Operating data: Number of power-up's | 0 - 9999 | | 7 | 73 |
| 604 | Operating data: Number of overtemp. | 0 - 9999 | | 6 | 0 |
| 605 | Operating data: Number of overvoltages | 0 - 9999 | | 6 | 0 |
| 615 | Fault log, read-out: Error code | Index XX - XXX | | 6 | 0 |
| 616 | Fault log, read-out: Time | Index XX - XXX | | 5 | 0 |
| 617 | Fault log, read-out: Value | Index XX - XXX | | 7 | -1 |
| 619 | Reset of hours-run counter | No reset/reset | No reset | 3 | 0 |
| 620 | Operation mode | 3 | Normal function | 5 | 0 |
| 621 | Nameplate: FC motor type | Depends on unit | | 5 | 0 |
| 624 | Nameplate: Software version no. | Depends on unit | | 9 | 0 |
| 625 | LCP version | Depends on unit | | 9 | 0 |
| 626 | Nameplate: Database identification no. | Depends on unit | | 9 | 0 |
| 628 | Nameplate: Application option type | | | 9 | -2 |
| 630 | Nameplate: Communication option type | | | 9 | 0 |
| 632 | BMC software identification | | | 9 | 0 |
| 633 | Motor database identification | | | 9 | 0 |
| 634 | Unit identification for communication | | | 9 | 0 |
| 635 | Software part No. | | | 9 | 0 |
| 678 | Configure Control Card | | Depends on unit | 5 | 0 |

Conversion index:

See *Databytes* in *Serial Bus*.

This number refers to a conversion figure to be used when writing or reading via serial communication with a frequency converter.

Data type:

Data type shows the type and length of the telegram.

| Data type | Description |
|-----------|-------------|
| 3 | Integer 16 |
| 4 | Integer 32 |
| 5 | Unsigned 8 |
| 6 | Unsigned 16 |
| 7 | Unsigned 32 |
| 9 | Text string |

■ Index
A

| | |
|-------------------------|-----|
| Acoustic noise | 92 |
| Active Setup | 37 |
| Address | 71 |
| Aggressive environments | 98 |
| Air humidity | 94 |
| Alarm word | 101 |
| alarms | 99 |
| Alignment | 23 |

B

| | |
|-----------------------------|----|
| Baudrate | 71 |
| Bearings | 19 |
| BMC software identification | 80 |
| Bolt torques | 24 |
| Broadcast | 82 |
| Bus jog 1 | 72 |
| Bus jog 2 | 72 |
| Bus time interval | 72 |
| Bus time interval function | 73 |

C

| | |
|---|----|
| Catch up/slow down value | 50 |
| CE labelling | 95 |
| Changing data | 30 |
| cleaning of the FC motor | 24 |
| Coasting | 71 |
| Compliance with EMC directive 89/336/EEC | 96 |
| Configuration | 42 |
| Control and reply telegrams | 82 |
| Control card, analogue inputs: | 14 |
| Control card, digital/pulse and analogue outputs: | 14 |
| Control card, digital/pulse inputs: | 13 |
| Control card, pulse input: | 14 |
| Control card, RS 485 serial communication: | 14 |
| Control characteristics | 14 |
| Control keys | 27 |
| Control Panel | 26 |
| Control structures | 7 |
| Copying of Setups | 37 |
| Current limit for motor mode | 51 |

D

| | |
|---|----|
| Data control byte (BCC) | 83 |
| Data read-out: Alarm word | 75 |
| Data read-out: Control word | 76 |
| Data read-out: Current | 74 |
| Data read-out: DC link voltage | 74 |
| Data read-out: Digital input | 75 |
| Data read-out: Extended status word | 76 |
| Data read-out: External reference % | 75 |
| Data read-out: FC therm. | 75 |
| Data read-out: Feedback | 73 |
| Data read-out: Frequency | 73 |
| Data read-out: INV. temperature | 75 |
| Data read-out: Motor voltage | 74 |
| Data read-out: Power, HP | 74 |
| Data read-out: Power, kW | 74 |
| Data read-out: Reference % | 73 |
| Data read-out: Reference unit | 73 |
| Data read-out: Status word, binary | 75 |
| Data read-out: Terminal 1, analogue input | 76 |

| | |
|---|----|
| Data read-out: Terminal 2, analogue input | 77 |
| Data read-out: Torque | 74 |
| Data read-out: Warning word | 76 |
| Databytes | 83 |
| DC brake cut-in frequency | 43 |
| DC braking time | 43 |
| DC braking voltage | 44 |
| DC-brake | 71 |
| Derating for air pressure | 93 |
| Derating for ambient temperature | 93 |
| Derating for high switching frequency | 93 |
| Derating for running at low speed | 93 |
| Dimensions | 20 |
| Display | 26 |
| Display line 1.1 | 39 |
| Display line 1.2 | 39 |
| Display line 1.3 | 39 |
| Display line 2 | 38 |
| Display mode | 28 |
| Display read-out state | 28 |
| Display scaling of motor frequency | 38 |
| Disposal Instruction | 4 |

E

| | |
|----------------------------|----|
| Earth leakage current | 91 |
| Efficiency | 95 |
| EMC directive | 96 |
| EMC standards | 97 |
| Externals | 14 |
| Extreme running conditions | 92 |

F

| | |
|-------------------------------------|----|
| Fault log | 78 |
| Fault log: Time | 79 |
| Fault log: Value | 79 |
| FCM 300 Thermal Protection | 25 |
| FCM 305-375 for 3 phases, 380-480 V | 13 |
| Feedback | 67 |
| feedback range | 65 |
| Flying start | 69 |
| Forced ventilation (FV) units | 25 |
| Frequency bypass 1 | 51 |
| Frequency bypass, bandwidth | 51 |
| Function after time out | 53 |

G

| | |
|---------------------------|----|
| Galvanic isolation (PELV) | 91 |
|---------------------------|----|

H

| | |
|-----------------------|----|
| Handling the FC motor | 19 |
|-----------------------|----|

I

| | |
|--|----|
| Initialisation | 79 |
| Installation of the FC motor | 23 |
| Integration of frequency converter and motor | 7 |
| Inverter versions | 9 |

J

| | |
|---------------|----|
| Jog frequency | 49 |
| Jog ramp time | 49 |

K

| | |
|--------------------------------|---|
| Key diagram for FCM 300 Series | 8 |
|--------------------------------|---|

L

| | |
|-----------------------------------|----|
| Language | 36 |
| LCD-display | 26 |
| LCP copy | 37 |
| LED | 27 |
| LED 300-304 | 16 |
| LEDs | 27 |
| Load compensation | 44 |
| Local Control/Configuration | 39 |
| Local jog | 40 |
| Local Operation Pad | 34 |
| Local reference | 36 |
| Local reference | 36 |
| Local reset of trip | 41 |
| Local reversing | 40 |
| Local stop | 40 |
| Local/remote control | 36 |
| Lock for data change | 41 |
| Lowpass filter | 66 |
| low-voltage directive (73/23/EEC) | 96 |

M

| | |
|-------------------------------------|----|
| machinery directive | 95 |
| Mains drop-out | 92 |
| Mains supply interference/harmonics | 95 |
| Mains supply | 13 |
| Max. output frequency | 47 |
| Maximum feedback | 64 |
| Maximum reference | 48 |
| Menu mode | 30 |
| Menu structure | 32 |
| Min. output frequency | 47 |
| Minimum feedback | 64 |
| Minimum reference | 48 |
| Motor current | 43 |
| Motor database identification | 80 |
| Motor frequency | 42 |
| Motor power | 42 |
| Motor voltage | 42 |
| Motor-generated overvoltage | 92 |

N

| | |
|--|----|
| Nameplate: Application option type | 80 |
| Nameplate: Communication option type | 80 |
| Nameplate: Database identification no. | 80 |
| Nameplate: FC type | 79 |
| Nameplate: Software version no. | 80 |

O

| | |
|--|----|
| Operating data: Hours run | 78 |
| Operating data: Number of overtemperatures | 78 |
| Operating data: Number of overvoltages | 78 |
| Operating data: Number of power-up's | 78 |
| Operating data: Operating hours | 78 |
| Operating mode | 79 |
| Operating state at power up, local control | 41 |
| Ordering | 9 |
| Output shafts | 19 |
| Overmodulation function | 63 |

P

| | |
|-------------------------------------|----|
| Parameter bytes | 83 |
| Parameter number (PNU) | 84 |
| Parameter selection | 29 |
| PC Software tools | 82 |
| Periodic maintenance of motor part. | 24 |
| Plug kit | 33 |
| Potentiometer option (177N0011) | 34 |
| Power factor | 95 |
| Process bytes | 83 |
| Process PID anti windup | 67 |
| Process PID diff. gain limit | 69 |
| Process PID differentiation time | 68 |
| Process PID integral time | 68 |
| Process PID lowpass filter time | 69 |
| Process PID Normal/inverse control | 67 |
| Process PID proportional gain | 68 |
| Process PID start frequency | 68 |
| Process-bytes | 85 |
| Product range | 9 |
| Programming Setup | 37 |

Q

| | |
|---------------------------|----|
| Quick menu | 29 |
| Quick stop ramp-down time | 49 |
| Quick-stop | 71 |

R

| | |
|----------------------------|----|
| Ramp-down time 1 | 48 |
| Ramp-down time 2 | 49 |
| Ramp-up time 1 | 48 |
| Ramp-up time 2 | 49 |
| Rated motor speed | 43 |
| RCD | 91 |
| Reference | 65 |
| Reference function | 50 |
| Reference preset 1 | 52 |
| Reference preset 2 | 52 |
| Reference preset 3 | 52 |
| Reference preset 4 | 52 |
| Reference preset 5 | 52 |
| Reference preset 6 | 52 |
| Reference preset 7 | 52 |
| Reference/feedback range | 47 |
| Relay output: | 14 |
| Remote mounting kit | 33 |
| Reset function | 62 |
| Reset of hours-run counter | 79 |
| Resonance damping | 43 |
| Reversing | 71 |
| Rotation direction | 47 |

S

| | |
|--------------------|----|
| Safety regulations | 5 |
| Selection of Setup | 71 |
| Selection of speed | 71 |
| Serial bus | 82 |
| Service plug kit | 33 |
| Sleep mode | 60 |
| Slip compensation | 45 |
| Start | 71 |
| Start voltage | 44 |
| Static overload | 92 |

| | |
|---------------------|----|
| Switching frequency | 63 |
| Switching pattern | 69 |

T

| | |
|------------------------------------|----|
| technical data | 13 |
| Telegram build-up | 82 |
| Telegram communication | 82 |
| Telegram length (LGE) | 82 |
| Telegram profile | 72 |
| Terminal 1, analogue input current | 54 |
| Terminal 1, max. scaling | 57 |
| Terminal 1, min. scaling | 57 |
| Terminal 2, analogue/digital input | 54 |
| Terminal 2, max. scaling | 58 |
| Terminal 2, min. scaling | 57 |
| Terminal 3, digital input | 54 |
| Terminal 4, digital input | 54 |
| Terminal 5, digital input | 54 |
| Terminal arrangement | 15 |
| The differentiator | 66 |
| Time out | 53 |
| Torque characteristics: | 13 |

U

| | |
|---------------------------------------|----|
| U/f ratio | 44 |
| UL standard | 94 |
| Unit identification for communication | 80 |

V

| | |
|------------------------------|----|
| Variable switching frequency | 63 |
| Vibration and shock | 94 |
| VLT address (ADR) | 83 |

W

| | |
|----------------------------------|-----|
| Warning against unintended start | 5 |
| Warning word | 101 |
| Warnings | 99 |