

## Contents

<b>1. Safety</b>	<b>3</b>
Safety Instructions	3
General Warning	4
Before Commencing Repair Work	4
Special conditions	4
Avoid unintended Start	6
Safe Stop of the Frequency Converter	7
IT Mains	8
<b>2. Introduction</b>	<b>9</b>
Type Code String	10
<b>3. Mechanical installation</b>	<b>13</b>
Before starting	13
How to install	14
<b>4. Electrical installation</b>	<b>21</b>
How to connect	21
Mains wiring overview	24
How to connect motor - foreword	28
Motor wiring overview	30
Motor connection for C1 and C2	33
How to Test Motor and Direction of Rotation.	35
<b>5. How to operate the frequency converter</b>	<b>41</b>
Three ways of operating	41
How to operate graphical LCP (GLCP)	41
How to operate numeric LCP (NLCP)	47
Tips and tricks	52
<b>6. How to programme the frequency converter</b>	<b>55</b>
How to programme	55
Initialisation to Default Settings	86
Parameter list	88
0-** Operation and Display	89
1-** Load/Motor	91
2-** Brakes	92
3-** Reference/Ramps	93
4-** Limits/Warnings	94
5-** Digital In/Out	95
6-** Analog In/Out	97

8-** Comm. and Options	99
9-** Profibus	100
10-**CAN Fieldbus	101
11-** LonWorks	102
13-** Smart Logic	103
14-** Special Functions	104
15-** FC Information	105
16-** Data Readouts	107
18-** Data Readouts 2	109
20-** FC Closed Loop	110
21-** Ext. Closed Loop	111
22-** Application Functions	113
23-** Timed Actions	115
25-** Cascade Controller	116
26-** Analog I/O Option MCB 109	118
<b>7. Troubleshooting</b>	<b>121</b>
Warning/Alarm list	123
<b>8. Specifications</b>	<b>129</b>
General Specifications	129
Special Conditions	138
Purpose of derating	138
Automatic adaptations to ensure performance	141
<b>Index</b>	<b>142</b>

# 1. Safety

1

## 1.1.1. Symbols

Symbols used in this Operating Instructions.

**NB!**

Indicates something to be noted by the reader.



Indicates a general warning.



Indicates a high-voltage warning.

\*

Indicates default setting

## 1.1.2. High Voltage Warning



The voltage of the frequency converter is dangerous whenever it is connected to mains. Incorrect installation of the motor or frequency converter may cause damage to the equipment, serious injury or death. Consequently, it is essential to comply with the instructions in this manual as well as local and national rules and safety regulations.

**Installation at high altitudes:**

At altitudes above 2 km, please contact Danfoss Drives regarding PELV.

## 1.1.3. Safety Instructions

- Make sure the frequency converter is properly connected to earth.
- Do not remove mains connections, motor connections or other power connections while the frequency converter is connected to mains.
- Protect users against supply voltage.
- Protect the motor against overloading according to national and local regulations.
- Motor overload protection is included in the default settings. Parameter 1-90 *Motor thermal protection* is set to value *ETR trip*. For the North American market: ETR functions provide class 20 motor overload protection, in accordance with NEC.
- The earth leakage current exceeds 3.5 mA.
- The [OFF] key is not a safety switch. It does not disconnect the frequency converter from mains.

### 1.1.4. General Warning



**Warning:**

Touching the electrical parts may be fatal - even after the equipment has been disconnected from mains.

Also make sure that other voltage inputs have been disconnected, (linkage of DC intermediate circuit), as well as the motor connection for kinetic back-up.

Before touching any potentially live parts of the VLT® HVAC Drive FC 100, wait at least as follows:

200 - 240 V, 1.1 - 3.7 kW: wait at least 4 minutes.

200 - 240 V, 5.5 - 45 kW: wait at least 15 minutes.

380 - 480 V, 1.1 - 7.5 kW: wait at least 4 minutes.

380 - 480 V, 11 - 90 kW, wait at least 15 minutes.

525 - 600 V, 1.1 - 7.5 kW, wait at least 4 minutes.

Shorter time is allowed only if indicated on the nameplate for the specific unit.



**Leakage Current**

The earth leakage current from the VLT® HVAC Drive FC 100 exceeds 3.5 mA. According to IEC 61800-5-1 a reinforced Protective Earth connection must be ensured by means of: a min. 10mm<sup>2</sup> Cu or 16mm<sup>2</sup> Al PE-wire or an additional PE wire - with the same cable cross section as the Mains wiring - must be terminated separately.

**Residual Current Device**

This product can cause a D.C. current in the protective conductor. Where a residual current device (RCD) is used for extra protection, only an RCD of Type B (time delayed) shall be used on the supply side of this product. See also RCD Application Note MN.90.GX.02.

Protective earthing of the VLT® HVAC Drive FC 100 and the use of RCD's must always follow national and local regulations.

### 1.1.5. Before Commencing Repair Work

1. Disconnect the frequency converter from mains
2. Disconnect DC bus terminals 88 and 89
3. Wait at least the time mentioned in section 1.1.6
4. Remove motor cable

### 1.1.6. Special conditions

**Electrical ratings:**

The rating indicated on the nameplate of the frequency converter is based on a typical 3-phase mains power supply, within the specified voltage, current and temperature range, which is expected to be used in most applications.

The frequency converters also support other special applications, which affect the electrical ratings of the frequency converter.

Special conditions which affect the electrical ratings might be:

- Single phase applications
- High temperature applications which require de-rating of the electrical ratings
- Marine applications with more severe environmental conditions.

Other applications might also affect the electrical ratings.

Consult the relevant clauses in these instructions and in the *VLT® HVAC Drive Design Guide* for information about the electrical ratings.

**Installation requirements:**

The overall electrical safety of the frequency converter requires special installation considerations regarding:

- Fuses and circuit breakers for over-current and short-circuit protection
- Selection of power cables (mains, motor, brake, loadsharing and relay)
- Grid configuration (IT, TN, grounded leg, etc.)
- Safety of low-voltage ports (PELV conditions).

Consult the relevant clauses in these instructions and in the *VLT® HVAC Drive Design Guide* for information about the installation requirements.

1

**1.1.7. Caution**



**Caution**

The frequency converter DC link capacitors remain charged after power has been disconnected. To avoid an electrical shock hazard, disconnect the frequency converter from the mains before carrying out maintenance. Wait at least as follows before doing service on the frequency converter:

Voltage	Min. Waiting Time	
	4 min.	15 min.
200 - 240 V	1.1 - 3.7 kW	5.5 - 45 kW
380 - 480 V	1.1 - 7.5 kW	11 - 90 kW
525 - 600 V	1.1 - 7.5 kW	

Be aware that there may be high voltage on the DC link even when the LEDs are turned off.

**1.1.8. Installation at High Altitudes (PELV)**



By altitudes above 2 km, please contact Danfoss Drives regarding PELV.

**1.1.9. Avoid unintended Start**

While the frequency converter is connected to mains, the motor can be started/stopped using digital commands, bus commands, references or via the Local Control Panel.

- Disconnect the frequency converter from mains whenever personal safety considerations make it necessary to avoid unintended start.
- To avoid unintended start, always activate the [OFF] key before changing parameters.
- Unless terminal 37 is turned off, an electronic fault, temporary overload, a fault in the mains supply, or lost motor connection may cause a stopped motor to start.

## 1.1.10. Safe Stop of the Frequency Converter

For versions fitted with a Safe Stop terminal 37 input, the frequency converter can perform the safety function *Safe Torque Off* (As defined by draft CD IEC 61800-5-2) or *Stop Category 0* (as defined in EN 60204-1).

It is designed and approved suitable for the requirements of Safety Category 3 in EN 954-1. This functionality is called Safe Stop. Prior to integration and use of Safe Stop in an installation, a thorough risk analysis on the installation must be carried out in order to determine whether the Safe Stop functionality and safety category are appropriate and sufficient. In order to install and use the Safe Stop function in accordance with the requirements of Safety Category 3 in EN 954-1, the related information and instructions of the VLT® HVAC Drive Design Guide MG.11.BX.YY must be followed! The information and instructions of the Operating Instructions are not sufficient for a correct and safe use of the Safe Stop functionality!

Prüf- und Zertifizierungsstelle im BG-PRÜFZERT		 <b>BGIA</b> <b>Berufsgenossenschaftliches Institut für Arbeitsschutz</b> Hauptverband der gewerblichen Berufsgenossenschaften	
<b>Translation</b> <small>In any case, the German original shall prevail.</small>		<b>Type Test Certificate</b>	
		05 06004 <small>No. of certificate</small>	
Name and address of the holder of the certificate: (customer)	Danfoss Drives A/S, Ulnoes 1 DK-6300 Graasten, Dänemark		
Name and address of the manufacturer:	Danfoss Drives A/S, Ulnoes 1 DK-6300 Graasten, Dänemark		
Ref. of customer:	Ref. of Test and Certification Body: Apf/Köh VE-Nr. 2003 23220	Date of Issue: 13.04.2005	
Product designation:	Frequency converter with integrated safety functions		
Type:	VLT® Automation Drive FC 302		
Intended purpose:	Implementation of safety function „Safe Stop“		
Testing based on:	EN 954-1, 1997-03, DKE AK 226.03, 1998-06, EN ISO 13849-2; 2003-12, EN 61800-3, 2001-02, EN 61800-5-1, 2003-09,		
Test certificate:	No.: 2003 23220 from 13.04.2005		
Remarks:	The presented types of the frequency converter FC 302 meet the requirements laid down in the test bases. With correct wiring a category 3 according to DIN EN 954-1 is reached for the safety function.		
The type tested complies with the provisions laid down in the directive 98/37/EC (Machinery). Further conditions are laid down in the Rules of Procedure for Testing and Certification of April 2004.			
Head of certification body	Certification officer		
			
(Prof. Dr. rer. nat. Dietmar Reinert)	(Dipl.-Ing. R. Apfeld)		
PZB10E 01.05 	Postal address: 53754 Sankt Augustin	Office: Alte Heerstraße 111 53757 Sankt Augustin	Phone: 0 22 41/2 31-02 Fax: 0 22 41/2 31-22 34  130BA491

Illustration 1.1: A similar certificate will be made available for the FC 102!

1

### 1.1.11. IT Mains

	<p><b>IT Mains</b></p> <p>Do not connect 400 V frequency converters with RFI-filters to mains supplies with a voltage between phase and earth of more than 440 V. For IT mains and delta earth (grounded leg), mains voltage may exceed 440 V between phase and earth.</p>
--	--

Par. 14-50 *RFI 1* can be used to disconnect the internal RFI capacitors from the RFI filter to ground. If this is done it will reduce the RFI performance to A2 level.

### 1.1.12. Software Version and Approvals: VLT HVAC Drive

<p><b>VLT HVAC Drive</b>  <b>Operating Instructions</b>  <b>Software version: 2.0X</b></p>	
<p>This Operating Instructions can be used for all VLT HVAC Drive frequency converters with software version 2.0X. The software version number can be seen from parameter 15-43.</p>	

### 1.1.13. Disposal Instruction

	<p>Equipment containing electrical components may not be disposed of together with domestic waste. It must be separately collected with Electrical and Electronic waste according to local and currently valid legislation.</p>
--	---



## 2. Introduction

### 2.1. Introduction

#### 2.1.1. Frequency Converter Identification

Below is an example of an identification label. This label is situated on the frequency converter and shows the type and options fitted to the unit. See table 2.1 for details of how to read the Type code string (T/C).

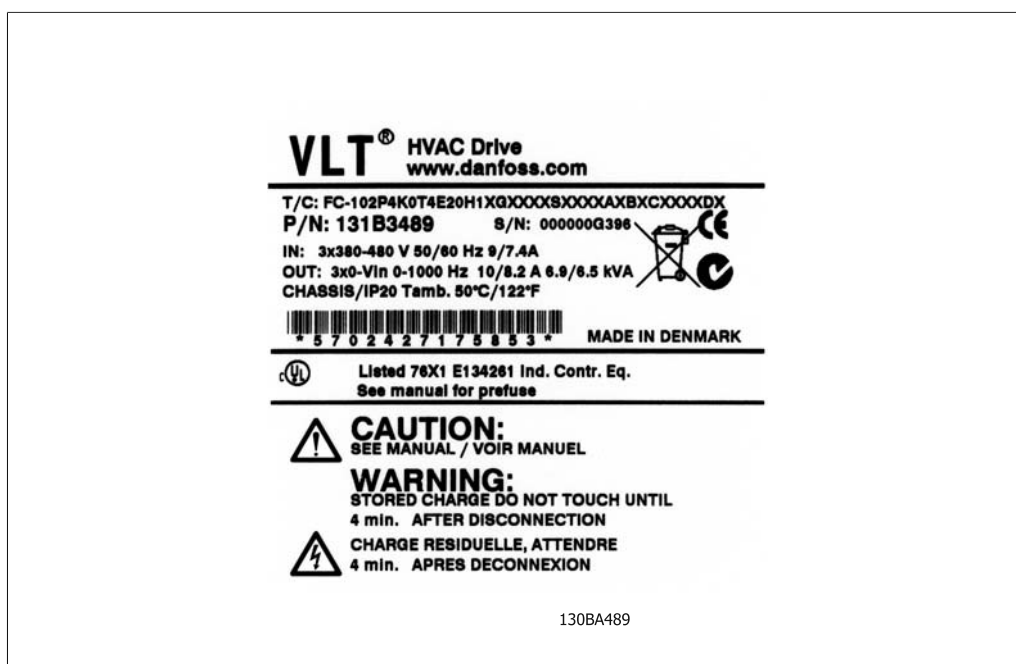
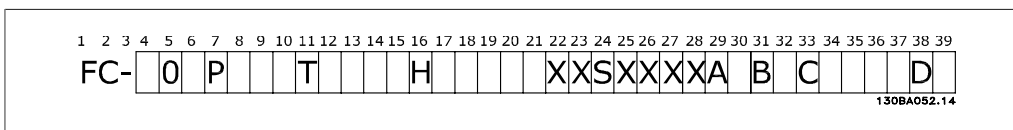

Illustration 2.1: This example shows an identification label.

Please have T/C (type code) number and serial number ready before contacting Danfoss.

### 2.1.2. Type Code String



Description	Pos	Possible choice
Product group & VLT Series	1-6	FC 102
Power rating	8-10	1.1 - 90 kW (1K1 - 90K)
Number of phases	11	Three phases (T)
Mains voltage	11-12	T 2: 200-240 V AC T 4: 380-480 V AC T 6: 525-600 V AC
Enclosure	13-15	E20: IP20 E21: IP 21/NEMA Type 1 E55: IP 55/NEMA Type 12 E66: IP66 P21: IP21/NEMA Type 1 w/backplate P55: IP55/NEMA Type 12 w/backplate
RFI filter	16-17	H1: RFI filter class A1/B H2: Class A2 H3:RFI filter A1/B (reduced cable length)
Brake	18	X: No brake chopper included B: Brake chopper included T: Safe Stop U: Safe + brake
Display	19	G: Graphical Local Control Panel (GLCP) N: Numeric Local Control Panel (NLCP) X: No Local Control Panel
Coating PCB	20	X: No coated PCB C: Coated PCB
Mains option	21	X: No Mains disconnect switch 1: With Mains disconnect switch (IP55 only)
Adaptation	22	Reserved
Adaptation	23	Reserved
Software release	24-27	Actual software
Software language	28	
A options	29-30	AX: No options A0: MCA 101 Profibus DP V1 A4: MCA 104 DeviceNet AG: MCA 108 LON works AJ: MCA 109 BAC Net
B options	31-32	BX: No option BK: MCB 101 General purpose I/O option BP: MCB 105 Relay option BO: MCB 109 Analog I/O
C0 options MCO	33-34	CX: No options
C1 options	35	X: No options
C option software	36-37	XX: Standard software
D options	38-39	DX: No option D0: DC back-up

Table 2.1: Type code description.

The various options are described further in the *VLT® HVAC Drive Design Guide*.

### 2.1.3. Symbols

Symbols used in this Operating Instructions.



**NB!**

Indicates something to be noted by the reader.



Indicates a general warning.



Indicates a high-voltage warning.

\*

Indicates default setting

## 2.1.4. Abbreviations and Standards

Terms:	Abbreviations:	SI-units:	I-P units:
Acceleration		m/s <sup>2</sup>	ft/s <sup>2</sup>
Alternating current	AC	A	Amp
American wire gauge	AWG		
Area		m <sup>2</sup>	in <sup>2</sup> , ft <sup>2</sup>
Automatic Motor Adaptation	AMA		
Centigrade	°C		
Current		A	Amp
Current limit	I <sub>LIM</sub>		
Direct current	DC	A	Amp
Drive Type Dependent	D-TYPE		
Electronic Thermal Relay	ETR		
Energy		J = N·m	ft·lb, Btu
Fahrenheit	°F		
Force		N	lb
Frequency Converter	FC		
Frequency		Hz	Hz
Graphical Local Control Panel	GLCP		
Heat transfer coefficient		W/m <sup>2</sup> ·K	Btu/hr·ft <sup>2</sup> ·°F
Kelvin	°K		
Kilohertz	kHz		
KiloVoltAmpere	KVA		
Length		m	inch, in, foot, ft
Local Control Panel	LCP		
Mass		kg	pound, lb
Milliampere	mA		
Millisecond	ms		
Minute	min		
Motion Control Tool	MCT		
Motor Type Dependent	M-TYPE		
Nanofarad	nF		
Newton Metres	Nm		
Nominal motor current	I <sub>M,N</sub>		
Nominal motor frequency	f <sub>M,N</sub>		
Nominal motor power	P <sub>M,N</sub>		
Nominal motor voltage	U <sub>M,N</sub>		
Numeric Local Control Panel	NLCP		
Parameter	par.		
Protective Extra Low Voltage	PELV		
Power		W	Btu/hr, hp
Pressure		Pa = N/m <sup>2</sup>	psi, psf, ft of water
Rated Inverter Output Current	I <sub>INV</sub>		
Revolutions Per Minute	RPM		
Size Related	SR		
Temperature		°C	°F
Time		s	s,hr
Torque limit	T <sub>LIM</sub>		
Velocity		m/s	fps, fpm, fph
Voltage		V	V
Volume		m <sup>3</sup>	in <sup>3</sup> , ft <sup>3</sup>

Table 2.2: Abbreviation and Standards table .

# 3. Mechanical installation

## 3.1. Before starting

### 3.1.1. Checklist

When unpacking the frequency converter, ensure that the unit is undamaged and complete. Use the following table to identify the packaging:

Enclosure type:	A2 (IP 20/IP 21)	A3 (IP 20/IP 21)	A5 (IP 55/IP 66)	B1 (IP 21/IP 55/IP 66)	B2 (IP 21/IP 55/IP 66)	C1 (IP 21/IP 55/66)	C2 (IP 21/IP 55/66)
<b>Unit size:</b>							
200-240 V	1.1-3.0 kW	3.7 kW	1.1-3.7 kW	5.5-11 kW	15 kW	18.5 - 30 kW	37 - 45 kW
380-480 V	1.1-4.0 kW	5.5-7.5 kW	1.1-7.5 kW	11-18.5 kW	22-30 kW	37 - 55 kW	75 - 90 kW
525-600 V	1.1-4.0 kW	5.5-7.5 kW					

Table 3.1: Unpacking table

Please note that a selection of screwdrivers (phillips or cross-thread screwdriver and torx), a side-cutter, drill and knife is also recommended to have handy for unpacking and mounting the frequency converter. The packaging for these enclosures contains, as shown: Accessories bag(s), documentation and the unit. Depending on options fitted there may be one or two bags and one or more booklets.

## 3.2. How to install

### 3.2.1. Mounting

The Danfoss VLT® series can be mounted side by side for all IP rating units but require 100 mm free space above and below for cooling. With regard to ambient temperature ratings, please see the chapter *Specifications*, section *Special Conditions*.

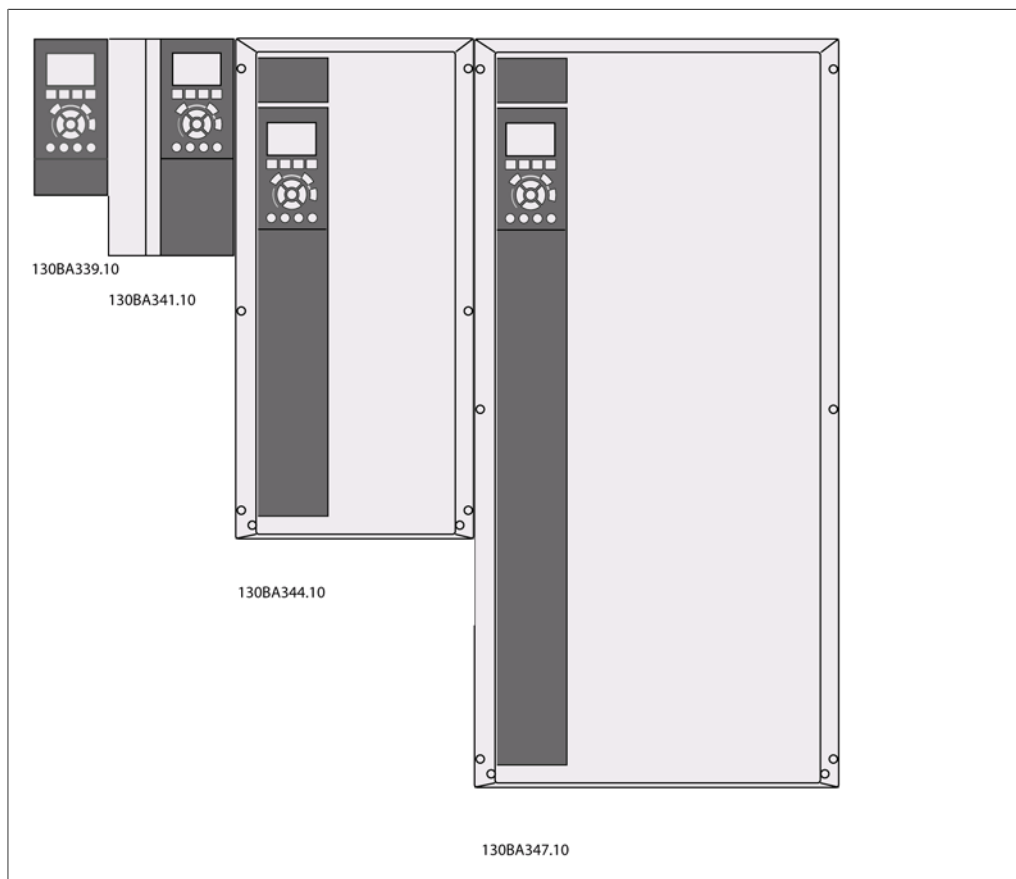

Illustration 3.1: Side by side mounting of all frame sizes.

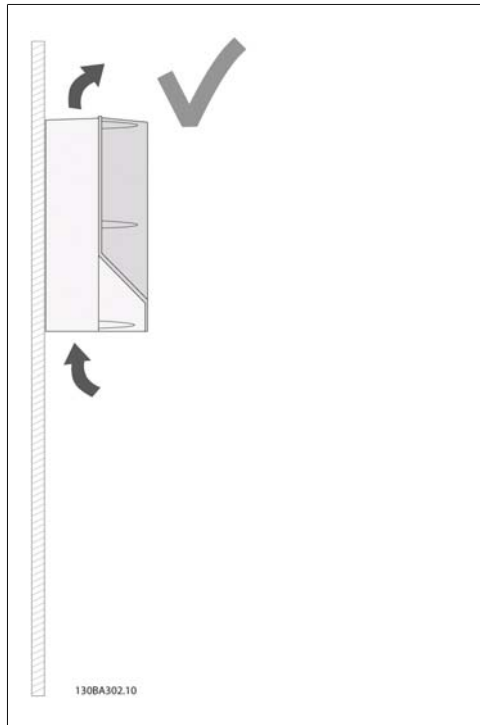

Illustration 3.2: This is the correct way to mount the unit.

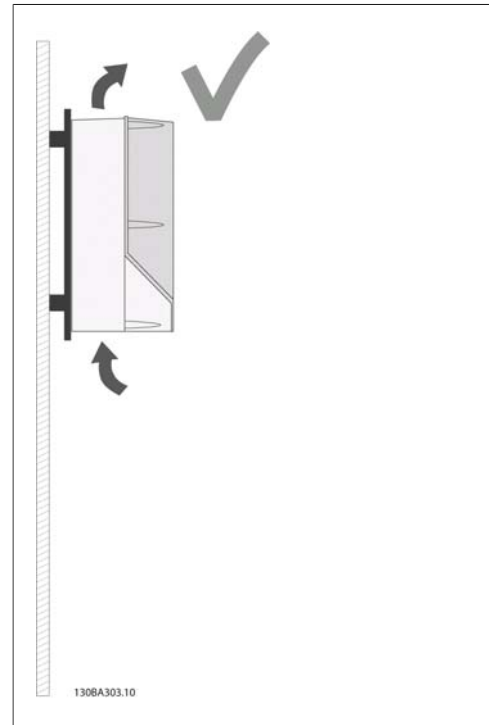

Illustration 3.4: If the unit must be mounted a small distance from the wall please order the back plate with the unit (see Ordering type code position 14-15). A2 and A3 units have back-plate as standard.

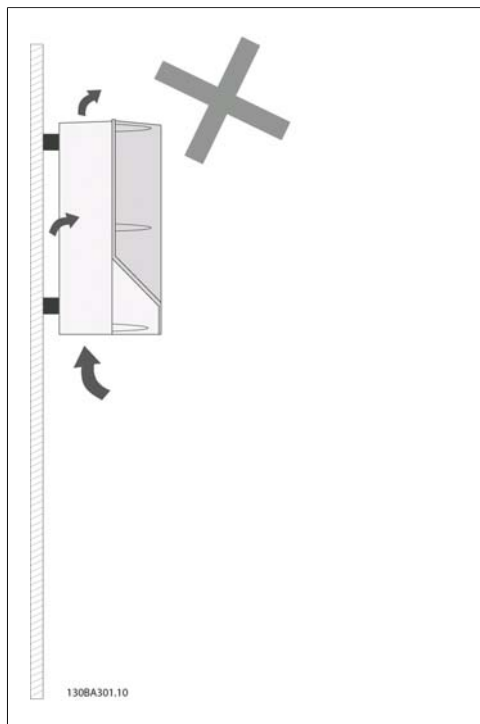

Illustration 3.3: Other than A2 and A3 enclosures do not mount units as shown without back plate. Cooling will be insufficient and service life can be drastically shortened.

Please use the following table to follow mounting instructions







Enclosure:	A2 (IP 20/ IP 21)	A3 (IP 20/ IP 21)	A5 (IP 55/ IP 66)	B1 (IP 21/ IP 55/ IP66)	B2 (IP 21/ IP 55/ IP66)	C1 (IP21/ IP 55/66)	C2 (IP21/ IP 55/66)
							
<b>Unit size:</b>							
200-240 V	1.1-3.0 kW	3.7 kW	1.1-3.7 kW	5.5-11 kW	15 kW	18.5 - 30 kW	37 - 45 kW
380-480 V	1.1-4.0 kW	5.5-7.5 kW	1.1-7.5 kW	11-18.5 kW	22-30 kW	37 - 55 kW	75 - 90 kW
525-600 V	1.1-4.0 kW	5.5-7.5 kW					

Table 3.2: Mounting table.

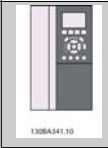
### 3.2.2. Mounting A2 and A3

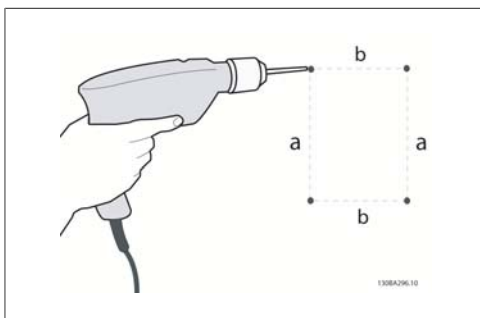

Illustration 3.5: Drilling of holes

Step 1: Drill according to the dimensions in the following table.

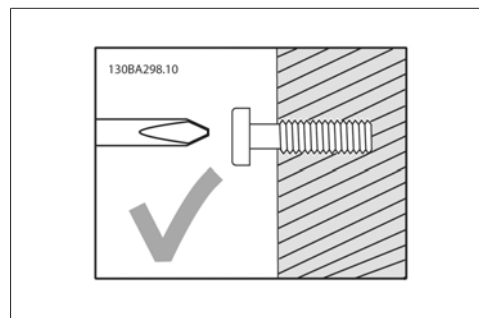

Illustration 3.6: Correct mounting of screws.

Step 2A: This way it is easy to hang the unit on the screws.



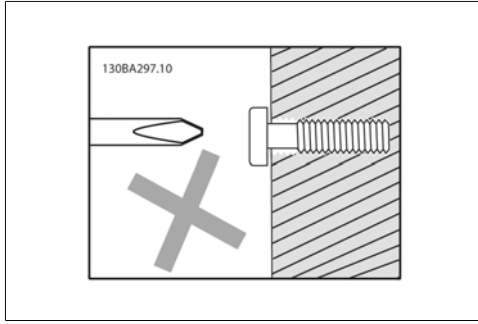

Illustration 3.7: Wrong mounting of screws.

Step 2B: Do not tighten screws completely.

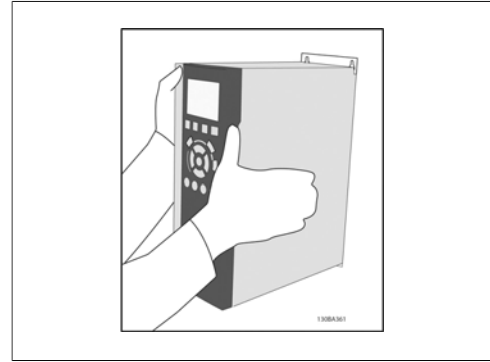

Illustration 3.8: Mounting of unit

Step 3: Lift the unit onto the screws.

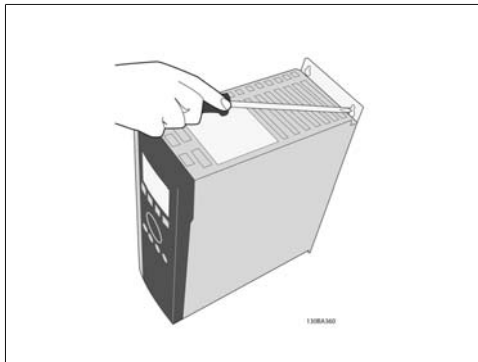
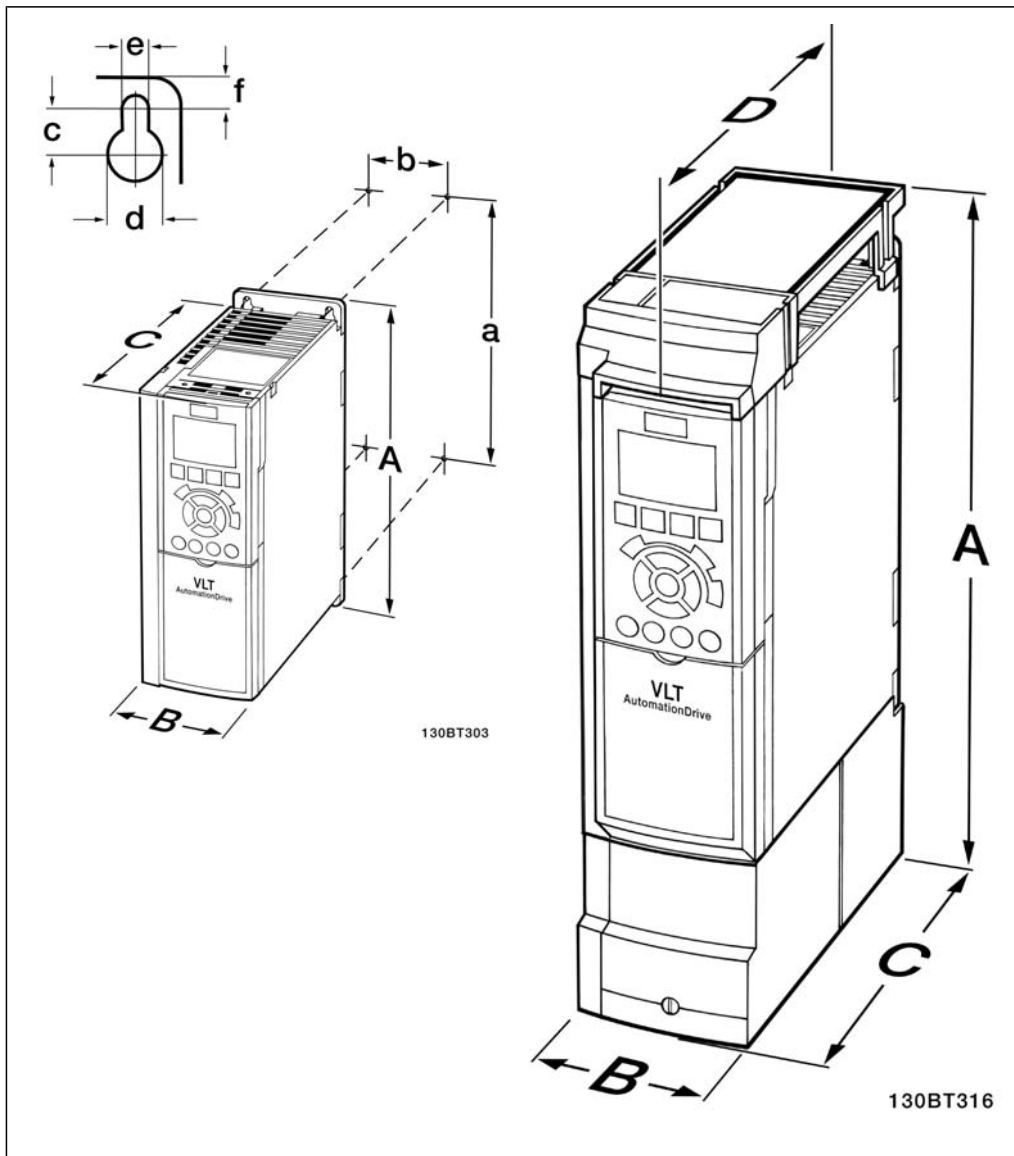

Illustration 3.9: Tightening of screws

Step 4: Tighten screws completely.

3



Mechanical dimensions					
		Frame size A2 1.1-3.0 kW (200-240 V) 1.1-4.0 kW (380-480 V) 1.1-4.0 kW (525-600 V)		Frame size A3 3.7 kW (200-240 V) 5.5-7.5 kW (380-480 V) 5.5-7.5 kW (525-600 V)	
		IP20	IP21/Type 1	IP20	IP21/Type 1
<b>Height</b>					
Height of back plate	A	268 mm	375 mm	268 mm	375 mm
Distance between mounting holes	a	257 mm	350 mm	257 mm	350 mm
<b>Width</b>					
Width of back plate	B	90 mm	90 mm	130 mm	130 mm
Distance between mounting holes	b	70 mm	70 mm	110 mm	110 mm
<b>Depth</b>					
Depth without option A/B	C	205 mm	205 mm	205 mm	205 mm
With option A/B	C	220 mm	220 mm	220 mm	220 mm
Without option A/B	D		207 mm		207 mm
With option A/B	D		222 mm		222 mm
<b>Screw holes</b>					
	c	8.0 mm	8.0 mm	8.0 mm	8.0 mm
	d	ø11 mm	ø11 mm	ø11 mm	ø11 mm
	e	ø5.5 mm	ø5.5 mm	ø5.5 mm	ø5.5 mm
	f	9 mm	9 mm	9 mm	9 mm
<b>Maximum weight</b>		4.9 kg	5.3 kg	6.6 kg	7.0 kg

Table 3.3: A2 and A3 mechanical dimensions

**NB!** Option A/B are serial communication and I/O options, which when fitted increase the depth on some enclosure sizes.

### 3.2.3. Mounting A5, B1, B2, C1 and C2.

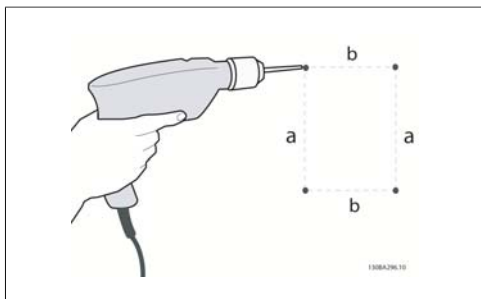

Illustration 3.10: Drilling holes.

Step 1: Drill according to the dimensions in the following table.

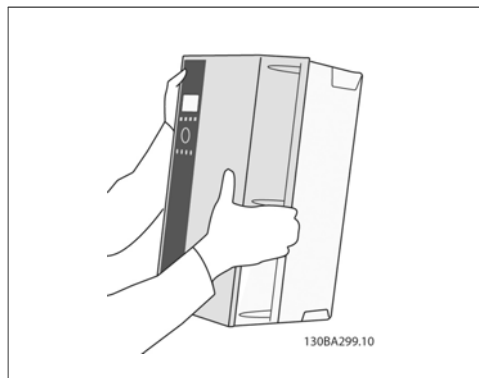

Illustration 3.13: Mounting of unit.

Step 3: Lift the unit onto the screws.

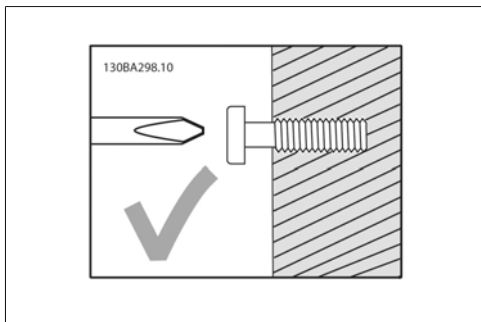

Illustration 3.11: Correct mounting of screws

Step 2A: This way it is easy to hang the unit on the screws.



Illustration 3.14: Tightening of screws

Step 4: Tighten screws completely.

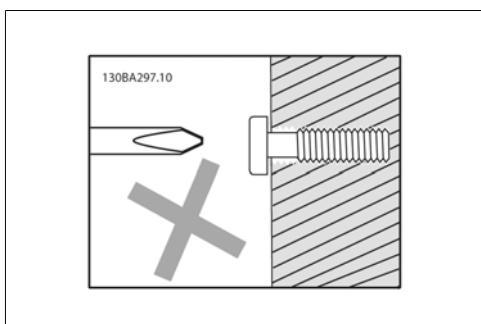
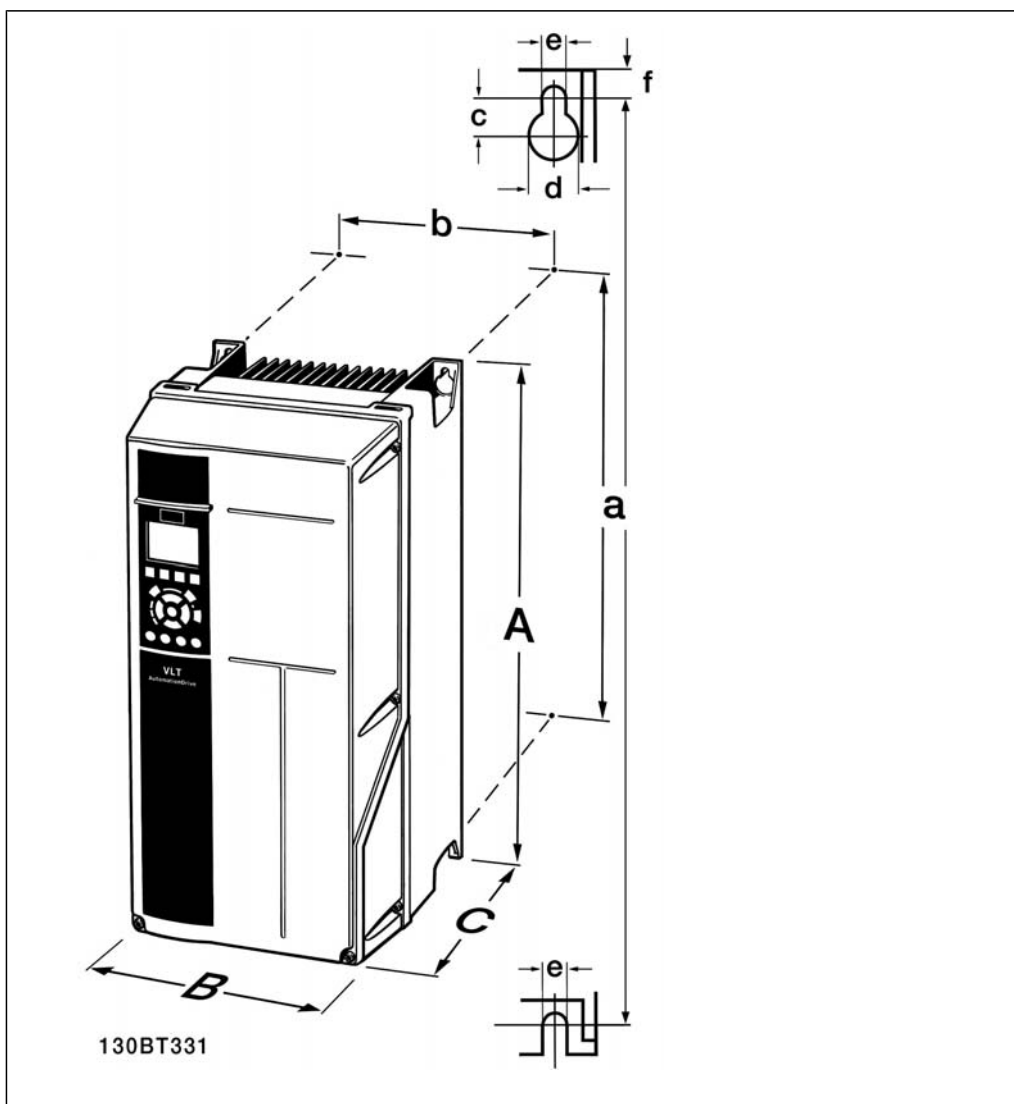

Illustration 3.12: Wrong mounting of screws

Step 2B: Do not tighten screws completely.



Mechanical dimensions		Frame size A5	Frame size B1	Frame size B2	Frame size C1	Frame size C2
Voltage:		1.1-3.7 kW	5.5-11 kW	15 kW	18.5 - 30 kW	37 - 45 kW
200-480 V		1.1-7.5 kW	11-18,5 kW	22-30 kW	37 - 55 kW	75 - 90 kW
380-480 V		IP55/66	IP21/55/66	IP21/55/66	IP21/55/66	IP21/55/66
<b>Height<sup>1)</sup></b>						
Height	A	420 mm	480 mm	650 mm	680 mm	770 mm
Distance between mounting holes	a	402 mm	454 mm	624 mm	648 mm	739 mm
<b>Width<sup>1)</sup></b>						
Width	B	242 mm	242 mm	242 mm	308 mm	370 mm
Distance between mounting holes	b	215 mm	210 mm	210 mm	272 mm	334 mm
<b>Depth</b>						
Depth	C	195 mm	260 mm	260 mm	310 mm	335 mm
<b>Screw holes</b>						
	c	8.25 mm	12 mm	12 mm	12.5 mm	12.5 mm
	d	ø12 mm	ø19 mm	ø19 mm	ø19 mm	ø19 mm
	e	ø6.5 mm	ø6.5 mm	ø6.5 mm	ø9	ø9
	f	9 mm	9 mm	9 mm	ø9.8	ø9.8
<b>Max. weight</b>		13.5 / 14.2	23 kg	27 kg	45 kg	65 kg

Table 3.4: A5, B1, B2, C1 and C2 mechanical dimensions.

1) The dimensions state the maximum height, width and depth needed for mounting the frequency converter, when the top cover is mounted.

## 4. Electrical installation

### 4.1. How to connect

#### 4.1.1. Cables General

**NB!**
**Cables General**

Always comply with national and local regulations on cable cross-sections.

**4**
**Details of terminal tightening torques.**

Enclosure	Power (kW)			Torque (Nm)					
	200-240 V	380-480 V	525-600 V	Line	Motor	DC connection	Brake	Earth	Relay
A2	1.1 - 3.0	1.1 - 4.0	1.1 - 4.0	1.8	1.8	1.8	1.8	3	0.6
A3	3.7	5.5 - 7.5	5.5 - 7.5	1.8	1.8	1.8	1.8	3	0.6
A5	1.1 - 3.7	1.1 - 7.5	1.1 - 7.5	1.8	1.8	1.8	1.8	3	0.6
B1	5.5 - 11	11 - 18.5	-	1.8	1.8	1.5	1.5	3	0.6
B2	-	22	-	2.5	2.5	3.7	3.7	3	0.6
	15	30	-	4.5	4.5	3.7	3.7	3	0.6
C1	18.5 - 30	37 - 55	-	10	10	10	10	3	0.6
C2	37	75	-	14	14	14	14	3	0.6
	45	90	-	24	24	14	14	3	0.6

Table 4.1: Tightening of terminals.

#### 4.1.2. Fuses

**Branch circuit protection**

In order to protect the installation against electrical and fire hazard, all branch circuits in an installation, switch gear, machines etc., must be shortcircuit and overcurrent protected according to the national/international regulations.

**Short circuit protection**

The frequency converter must be protected against short-circuit to avoid electrical or fire hazard. Danfoss recommends using the fuses mentioned in tables 4.3 and 4.4 to protect service personnel or other equipment in case of an internal failure in the unit. The frequency converter provides full short circuit protection in case of a short-circuit on the motor output.

**Over-current protection**

Provide overload protection to avoid fire hazard due to overheating of the cables in the installation. Over current protection must always be carried out according to national regulations. The frequency converter is equipped with an internal over current protection that can be used for upstream overload protection (UL-applications excluded). See VLT® HVAC Drive Programming Guide, par. 4-18. Fuses must be designed for protection in a circuit capable of supplying a maximum of 100,000 A<sub>rms</sub> (symmetrical), 500 V/600 V maximum.

## Non UL compliance

If UL/cUL is not to be complied with, Danfoss recommends using the fuses mentioned in table 4.2, which will ensure compliance with EN50178:

In case of malfunction, not following the recommendation may result in unnecessary damage to the frequency converter.

VLT HVAC	Max. fuse size	Voltage	Type
<b>200-240 V</b>			
K25-1K1	16A <sup>1</sup>	200-240 V	type gG
1K5	16A <sup>1</sup>	200-240 V	type gG
2K2	25A <sup>1</sup>	200-240 V	type gG
3K0	25A <sup>1</sup>	200-240 V	type gG
3K7	35A <sup>1</sup>	200-240 V	type gG
5K5	50A <sup>1</sup>	200-240 V	type gG
7K5	63A <sup>1</sup>	200-240 V	type gG
11K	63A <sup>1</sup>	200-240 V	type gG
15K	80A <sup>1</sup>	200-240 V	type gG
18K5	125A <sup>1</sup>	200-240 V	type gG
22K	125A <sup>1</sup>	200-240 V	type gG
30K	160A <sup>1</sup>	200-240 V	type gG
37K	200A <sup>1</sup>	200-240 V	type aR
45K	250A <sup>1</sup>	200-240 V	type aR
<b>380-500 V</b>			
11K	63A <sup>1</sup>	380-480 V	type gG
15K	63A <sup>1</sup>	380-480 V	type gG
18K	63A <sup>1</sup>	380-480 V	type gG
22K	63A <sup>1</sup>	380-480 V	type gG
30K	80A <sup>1</sup>	380-480 V	type gG
37K	100A <sup>1</sup>	380-480 V	type gG
45K	125A <sup>1</sup>	380-480 V	type gG
55K	160A <sup>1</sup>	380-480 V	type gG
75K	250A <sup>1</sup>	380-480 V	type aR
90K	250A <sup>1</sup>	380-480 V	type aR

Table 4.2: Non UL fuses 200 V to 500 V

1) Max. fuses - see national/international regulations for selecting an applicable fuse size.

## UL Compliance

VLT HVAC	Bussmann	Bussmann	Bussmann	SIBA	Littel fuse	Ferraz-Shawmut	Ferraz-Shawmut
<b>200-240 V</b>							
kW	Type RK1	Type J	Type T	Type RK1	Type RK1	Type CC	Type RK1
K25-1K1	KTN-R10	JKS-10	JJN-10	5017906-010	KLN-R10	ATM-R10	A2K-10R
1K5	KTN-R15	JKS-15	JJN-15	5017906-015	KLN-R15	ATM-R15	A2K-15R
2K2	KTN-R20	JKS-20	JJN-20	5012406-020	KLN-R20	ATM-R20	A2K-20R
3K0	KTN-R25	JKS-25	JJN-25	5012406-025	KLN-R25	ATM-R25	A2K-25R
3K7	KTN-R30	JKS-30	JJN-30	5012406-030	KLN-R30	ATM-R30	A2K-30R
5K5	KTN-R50	JKS-50	JJN-50	5012406-050	KLN-R50	-	A2K-50R
7K5	KTN-R50	JKS-60	JJN-60	5012406-050	KLN-R60	-	A2K-50R
11K	KTN-R60	JKS-60	JJN-60	5014006-063	KLN-R60	-	A2K-60R
15K	KTN-R80	JKS-80	JJN-80	5014006-080	KLN-R80	-	A2K-80R
18K5	KTN-R125	JKS-150	JJN-125	2028220-125	KLN-R125	-	A2K-125R
22K	KTN-R125	JKS-150	JJN-125	2028220-125	KLN-R125	-	A2K-125R
30K	FWX-150	-	-	2028220-150	L25S-150	-	A25X-150
37K	FWX-200	-	-	2028220-200	L25S-200	-	A25X-200
45K	FWX-250	-	-	2028220-250	L25S-250	-	A25X-250

Table 4.3: UL fuses 200 - 240 V

VLT HVAC	Bussmann	Bussmann	Bussmann	SIBA	Littel fuse	Ferraz-Shawmut	Ferraz-Shawmut
<b>380-500 V, 525-600</b>							
kW	Type RK1	Type J	Type T	Type RK1	Type RK1	Type CC	Type RK1
11K	KTS-R40	JKS-40	JJS-40	5014006-040	KLS-R40	-	A6K-40R
15K	KTS-R40	JKS-40	JJS-40	5014006-040	KLS-R40	-	A6K-40R
18K	KTS-R50	JKS-50	JJS-50	5014006-050	KLS-R50	-	A6K-50R
22K	KTS-R60	JKS-60	JJS-60	5014006-063	KLS-R60	-	A6K-60R
30K	KTS-R80	JKS-80	JJS-80	2028220-100	KLS-R80	-	A6K-80R
37K	KTS-R100	JKS-100	JJS-100	2028220-125	KLS-R100	-	A6K-100R
45K	KTS-R125	JKS-150	JJS-150	2028220-125	KLS-R125	-	A6K-125R
55K	KTS-R150	JKS-150	JJS-150	2028220-160	KLS-R150	-	A6K-150R
75K	FWH-220	-	-	2028220-200	L50S-225	-	A50-P225
90K	FWH-250	-	-	2028220-250	L50S-250	-	A50-P250

Table 4.4: UL fuses 380 - 600 V

KTS-fuses from Bussmann may substitute KTN for 240 V frequency converters.

FWH-fuses from Bussmann may substitute FWX for 240 V frequency converters.

KLSR fuses from LITTEL FUSE may substitute KLSR fuses for 240 V frequency converters.

L50S fuses from LITTEL FUSE may substitute L50S fuses for 240 V frequency converters.

A6KR fuses from FERRAZ SHAWMUT may substitute A2KR for 240 V frequency converters.

A50X fuses from FERRAZ SHAWMUT may substitute A25X for 240 V frequency converters.

### 4.1.3. Earthing and IT mains

**!** The earth connection cable cross section must be at least 10 mm<sup>2</sup> or 2 rated mains wires terminated separately according to EN 50178 or IEC 61800-5-1 unless national regulations specify differently.

The mains is connected to the main disconnect switch if this is included.

**NB!** Check that mains voltage corresponds to the mains voltage of the frequency converter name plate.

**IT Mains**  
Do not connect 400 V frequency converters with RFI-filters to mains supplies with a voltage between phase and earth of more than 440 V. For IT mains and delta earth (grounded leg), mains voltage may exceed 440 V between phase and earth.

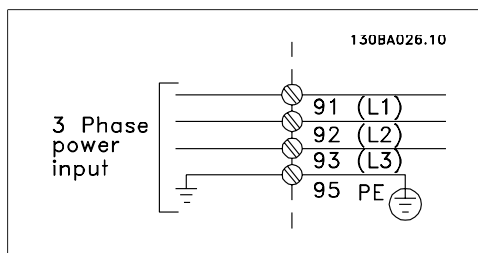

Illustration 4.1: Terminals for mains and earthing.

### 4.1.4. Mains wiring overview

Please use the following table to follow mains wiring connection instructions.

Enclosure:	A2 (IP 20/IP 21)	A3 (IP 20/IP 21)	A5 (IP 55/IP 66)	B1 (IP 21/IP 55/IP 66)	B2 (IP 21/IP 55/IP 66)	C1 (IP 21/IP 55/66)	C2 (IP 21/IP 55/66)
<b>Motor size:</b>							
200-240 V	1.1-3.0 kW	3.7 kW	1.1-3.7 kW	5.5-11 kW	15 kW	18.5-30 kW	37-45 kW
380-480 V	1.1-4.0 kW	5.5-7.5 kW	1.1-7.5 kW	11-18.5 kW	22-30 kW	37-55 kW	75-90 kW
525-600 V	2.2-4.0 kW	5.5-7.5 kW					
<b>Goto:</b>	<b>4.1.5</b>		<b>4.1.6</b>	<b>4.1.7</b>		<b>4.1.8</b>	

Table 4.5: Mains wiring table.



### 4.1.5. Mains connection for A2 and A3

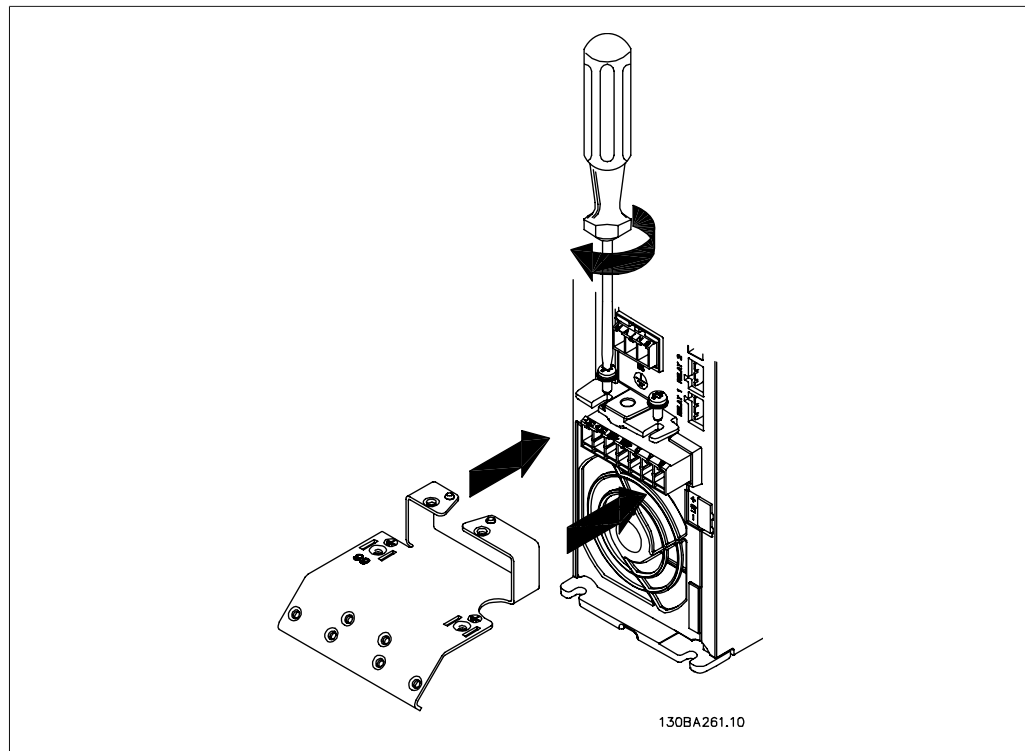

Illustration 4.2: Firstly mount the two screws in the mounting plate, slide it into place and tighten fully.

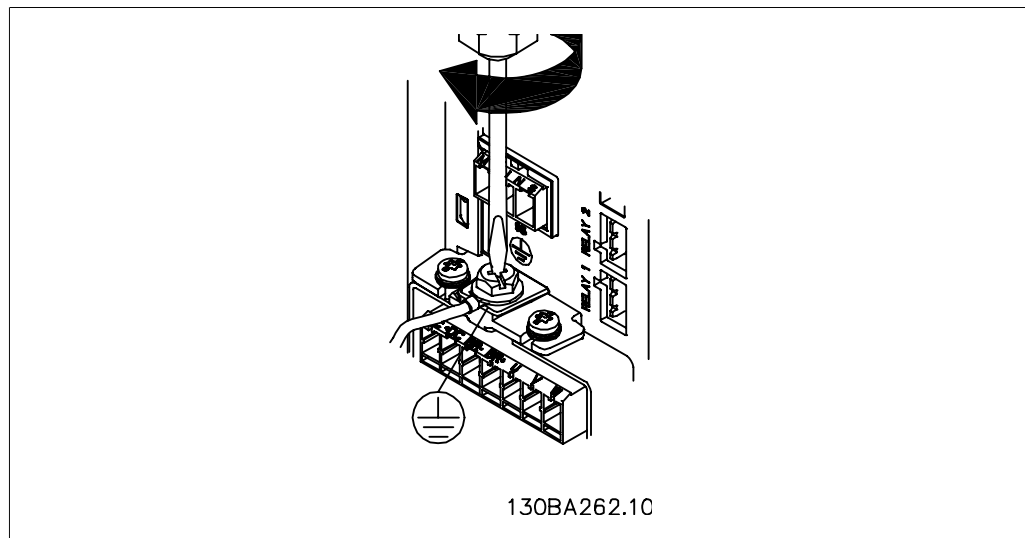

Illustration 4.3: When mounting cables, first mount and tighten earth cable.



The earth connection cable cross section must be at least 10 mm<sup>2</sup> or 2 rated mains wires terminated separately according to EN 50178/IEC 61800-5-1.

4

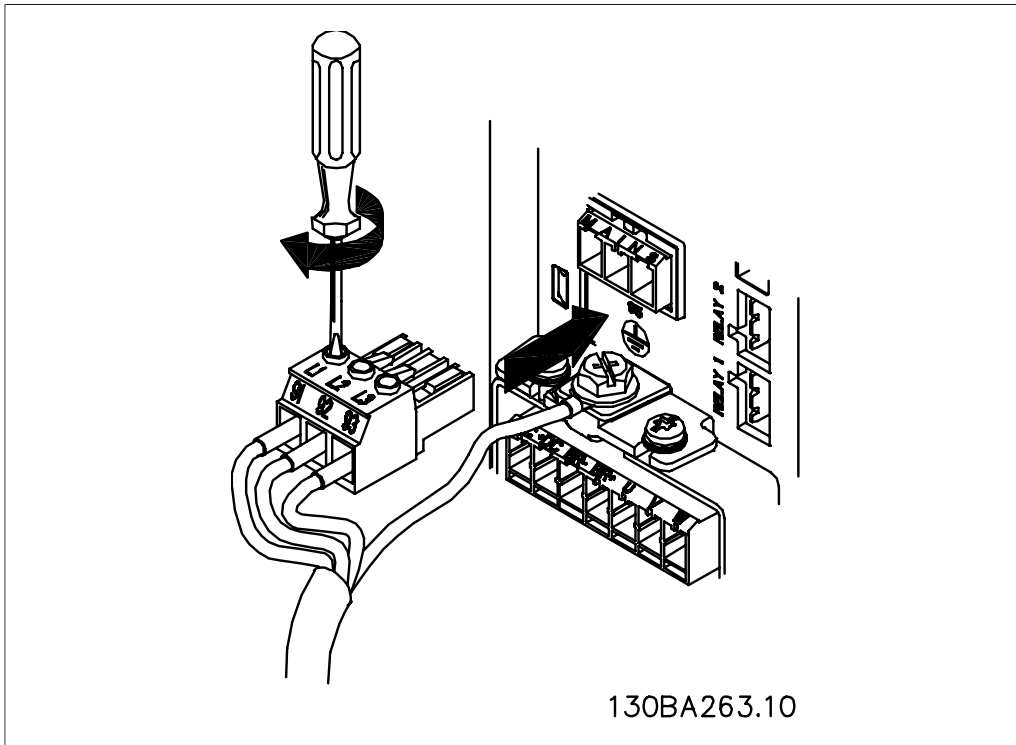

Illustration 4.4: Then mount mains plug and tighten wires.

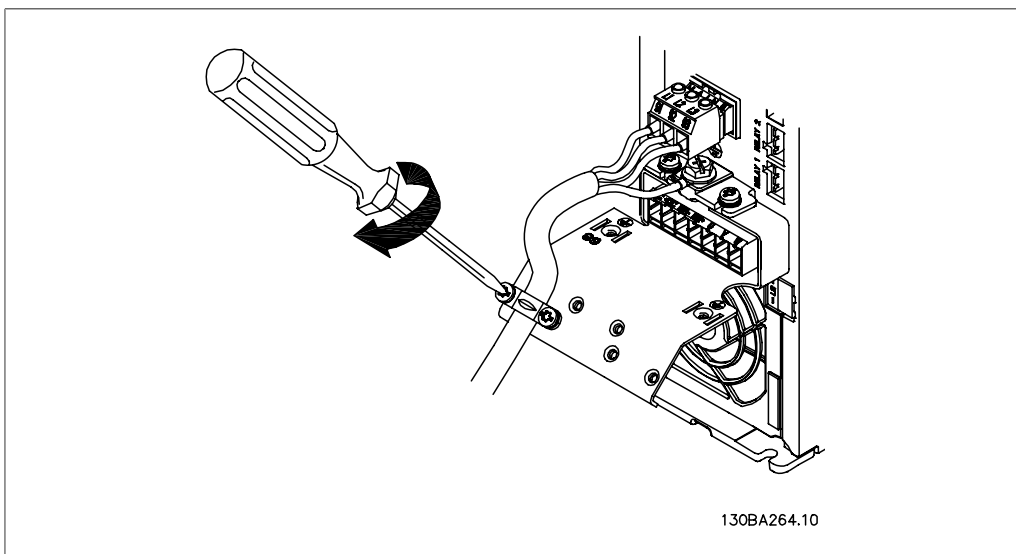

Illustration 4.5: Finally tighten support bracket on mains wires.

### 4.1.6. Mains connection for A5

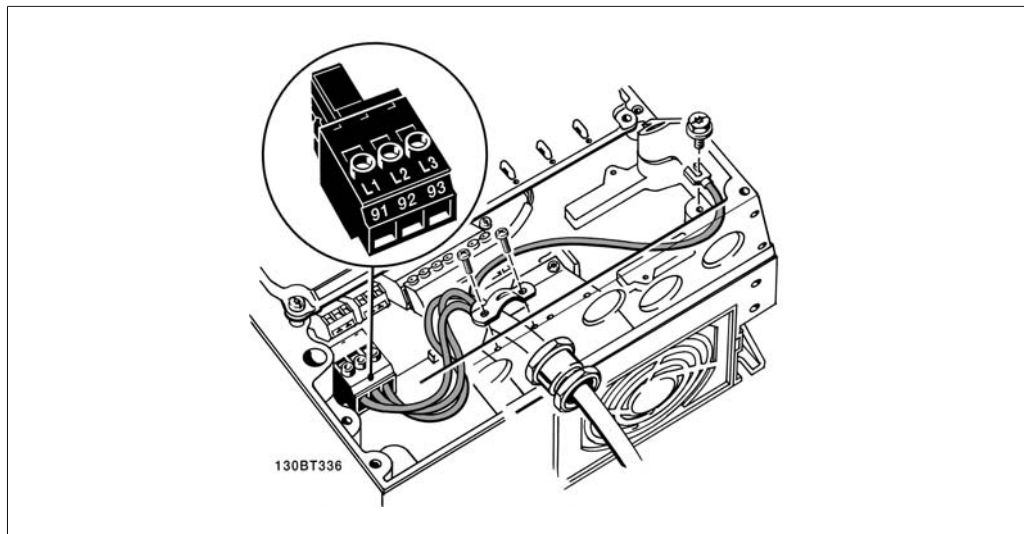

Illustration 4.6: How to connect to mains and earthing without mains disconnect switch. Note that a cable clamp is used.

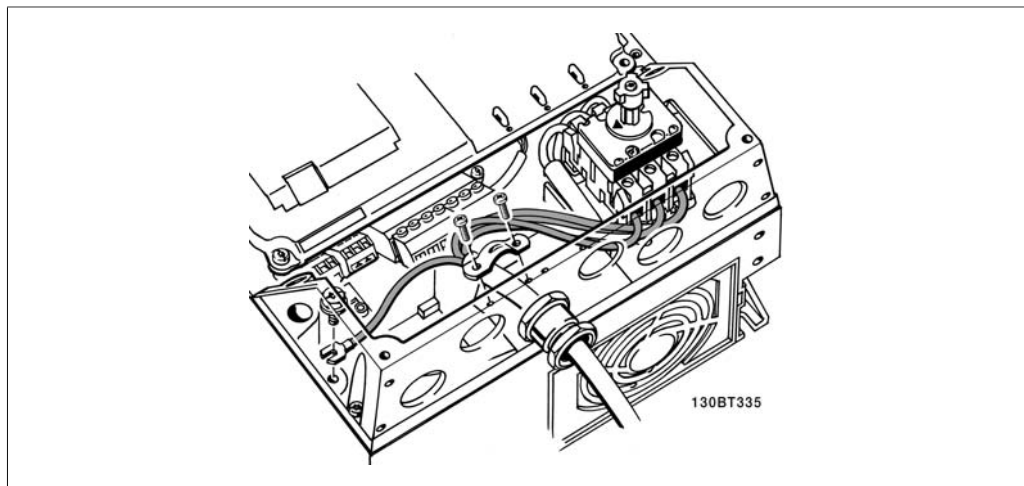

Illustration 4.7: How to connect to mains and earthing with mains disconnect switch.

#### 4.1.7. Mains connection for B1 and B2.

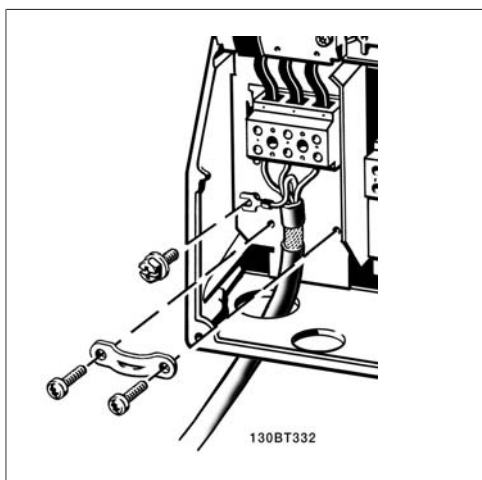

Illustration 4.8: How to connect to mains and earthing.

#### 4.1.8. Mains connection for C1 and C2.

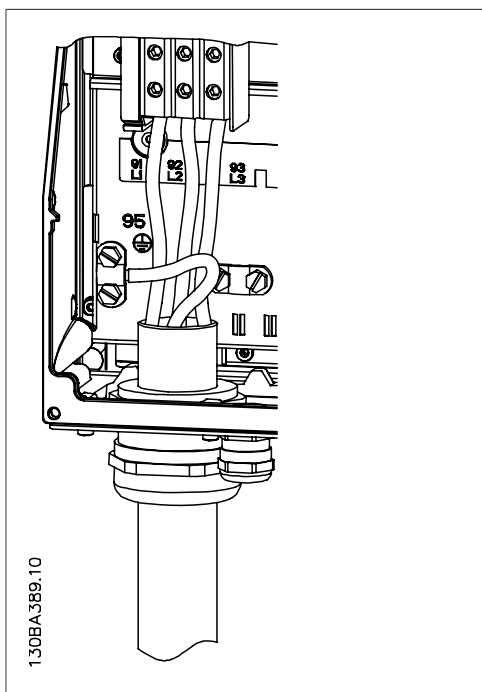

Illustration 4.9: How to connect to mains and earthing.

#### 4.1.9. How to connect motor - foreword

See section *General Specifications* for correct dimensioning of motor cable cross-section and length.

- Use a screened/armoured motor cable to comply with EMC emission specifications (or install the cable in metal conduit).
- Keep the motor cable as short as possible to reduce the noise level and leakage currents.

- Connect the motor cable screen/armor to both the decoupling plate of the frequency converter and to the metal of the motor. (Same applies to both ends of metal conduit if used instead of screen.)
- Make the screen connections with the largest possible surface area (cable clamp or by using an EMC cable gland). This is done by using the supplied installation devices in the frequency converter.
- Avoid terminating the screen by twisting the ends (pigtailed), as this will spoil high frequency screening effects.
- If it is necessary to break the continuity of the screen to install a motor isolator or motor relay, the continuity must be maintained with the lowest possible HF impedance.

#### **Cable length and cross-section**

The frequency converter has been tested with a given length of cable and a given cross-section of that cable. If the cross-section is increased, the cable capacitance - and thus the leakage current - may increase, and the cable length must be reduced correspondingly.

#### **Switching frequency**

When frequency converters are used together with sine wave filters to reduce the acoustic noise from a motor, the switching frequency must be set according to the sine wave filter instruction in *Par. 14-01*.

#### **Aluminium conductors**

Aluminium conductors are not recommended for cable cross sections below 35 mm<sup>2</sup>. Terminals can accept aluminium conductors but the conductor surface has to be clean and the oxidation must be removed and sealed by neutral acid free Vaseline grease before the conductor is connected.

Furthermore, the terminal screw must be retightened after two days due to the softness of the aluminium. It is crucial to ensure the connection makes a gas tight joint, otherwise the aluminium surface will oxidize again.

All types of three-phase asynchronous standard motors can be connected to the frequency converter. Normally, small motors are star-connected (230/400 V, D/Y). Large motors are delta-connected (400/690 V, D/Y). Refer to the motor name plate for correct connection mode and voltage.

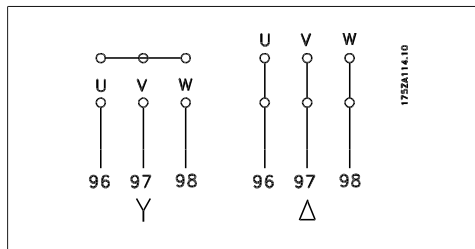

Illustration 4.10: Terminals for motor connection

4



**NB!**

In motors without phase insulation paper or other insulation reinforcement suitable for operation with voltage supply (such as a frequency converter), fit an Sine-wave filter on the output of the frequency converter. (Motors that comply with IEC 60034-17 do not require an Sine-wave filter).

No.	96	97	98	Motor voltage 0-100% of mains voltage.
	U	V	W	3 cables out of motor
	U1	V1	W1	6 cables out of motor, Delta-connected
	W2	U2	V2	
	U1	V1	W1	6 cables out of motor, Star-connected
				U2, V2, W2 to be interconnected separately (optional terminal block)
No.	99			Earth connection
	PE			

Table 4.6: 3 and 6 cable motor connection.

### 4.1.10. Motor wiring overview

Enclosure:	A2 (IP 20/IP 21)	A3 (IP 20/IP 21)	A5 (IP 55/IP 66)	B1 (IP 21/IP 55/ IP 66)	B2 (IP 21/IP 55/ IP 66)	C1 (IP 21/IP 55/ IP 66)	C2 (IP 21/IP 55/ IP 66)
<b>Motor size:</b>							
200-240 V	1.1-3.0 kW	3.7 kW	1.1-3.7 kW	5.5-11 kW	15 kW	18.5-30 kW	37-45 kW
380-480 V	1.1-4.0 kW	5.5-7.5 kW	1.1-7.5 kW	11-18.5 kW	22-30 kW	37-55 kW	75-90 kW
525-600 V	2.2-4.0 kW	5.5-7.5 kW					
<b>Goto:</b>	<b>4.1.11</b>		<b>4.1.12</b>	<b>4.1.13</b>		<b>4.1.14</b>	

Table 4.7: Motor wiring table.

### 4.1.11. Motor connection for A2 and A3

Follow these drawings step by step for connecting the motor to the frequency converter.

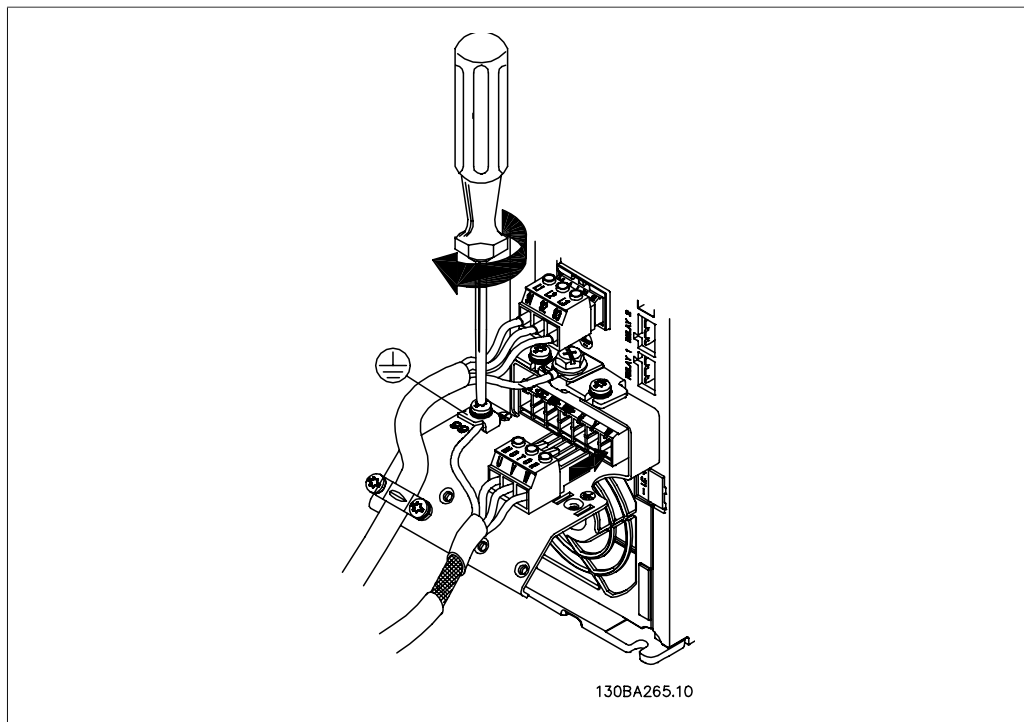

Illustration 4.11: First terminate the motor earth, then place motor U, V and W wires in plug and tighten.

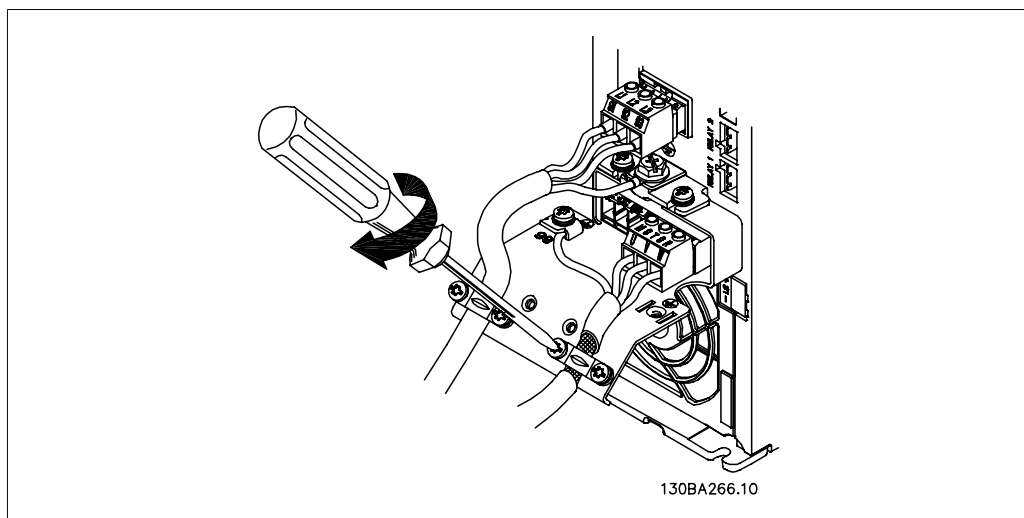

Illustration 4.12: Mount cable clamp to ensure 360 degree connection between chassis and screen, note the outer insulation of the motor cable is removed under the clamp.

#### 4.1.12. Motor connection for A5

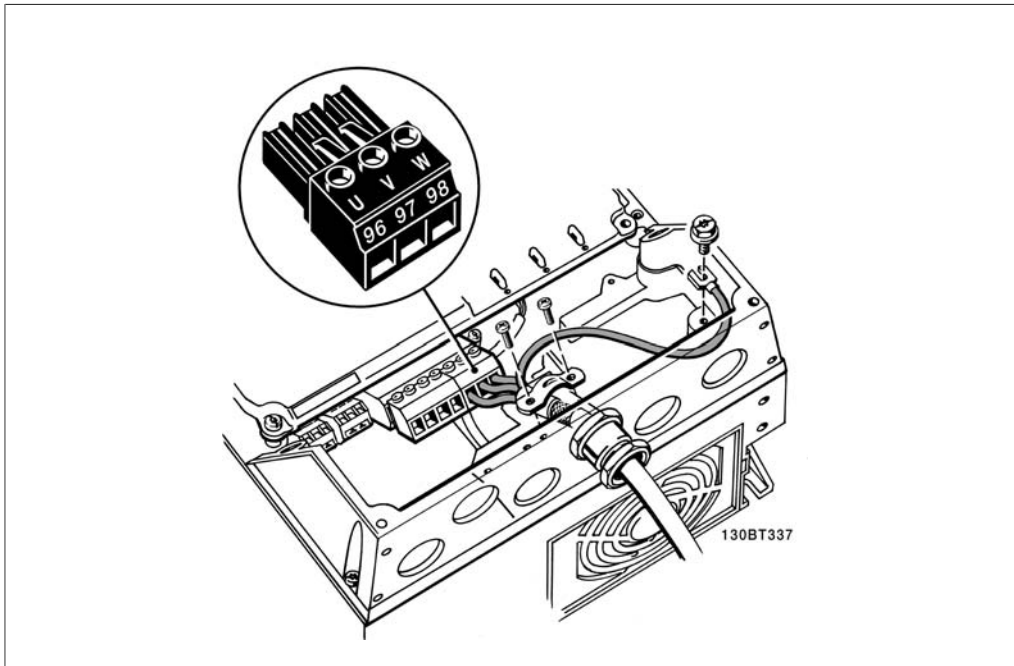

Illustration 4.13: First terminate the motor earth, then place motor U, V and W wires in terminal and tighten. Please ensure that the outer insulation of the motor cable is removed under the EMC clamp.

#### 4.1.13. Motor connection for B1 and B2

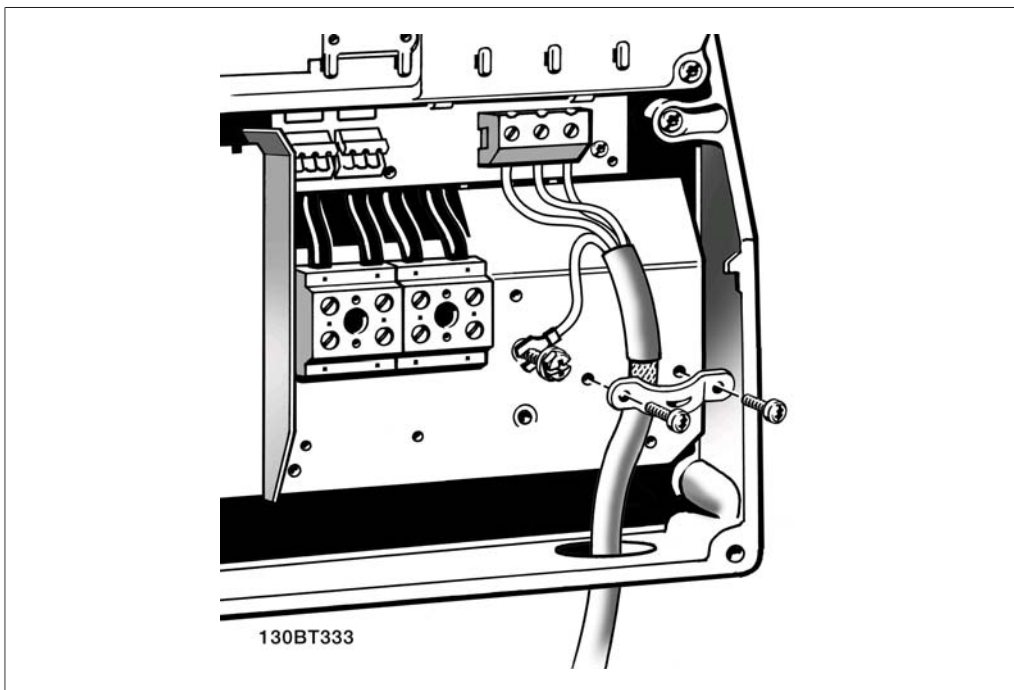

Illustration 4.14: First terminate the motor earth, then Place motor U, V and W wires in terminal and tighten. Please ensure that the outer insulation of the motor cable is removed under the EMC clamp.



#### 4.1.14. Motor connection for C1 and C2

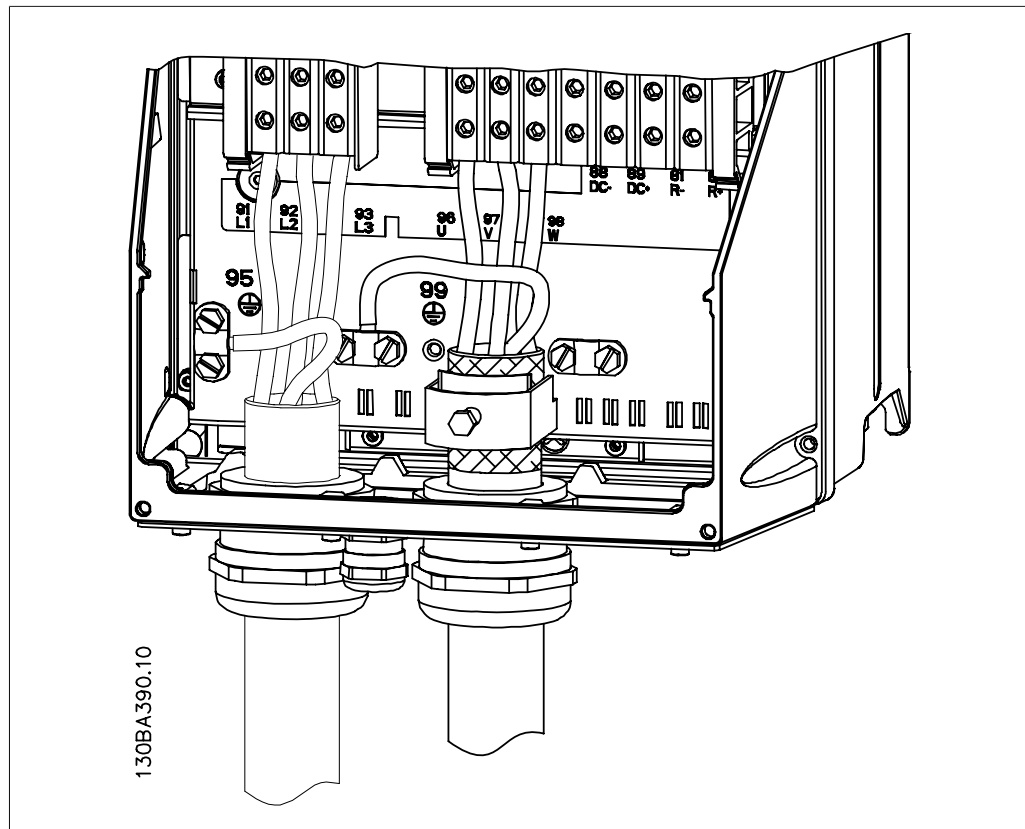

Illustration 4.15: First terminate the motor earth, then Place motor U, V and W wires in terminal and tighten. Please ensure that the outer insulation of the motor cable is removed under the EMC clamp.

#### 4.1.15. Wiring Example and Testing

The following section describes how to terminate control wires and how to access them. For an explanation of the function, programming and wiring of the control terminals, please see chapter, *How to programme the frequency converter*.

#### 4.1.16. Access to Control Terminals

All terminals to the control cables are located underneath the terminal cover on the front of the frequency converter. Remove the terminal cover with a screwdriver.



Illustration 4.16: A2 and A3 enclosures

Remove front-cover to access control terminals. When replacing the front-cover, please ensure proper fastening by applying a torque of 2 Nm.

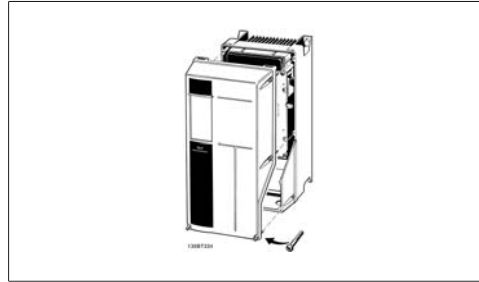

Illustration 4.17: A5, B1, B2, C1 and C2 enclosures

# 4

## 4.1.17. Control Terminals

Drawing reference numbers:

1. 10 pole plug digital I/O.
2. 3 pole plug RS-485 Bus.
3. 6 pole analog I/O.
4. USB connection.

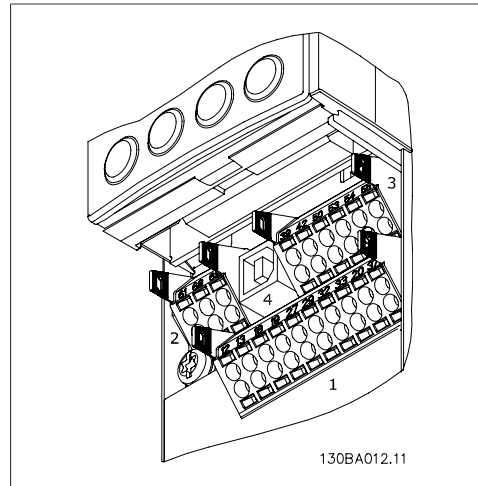



Illustration 4.18: Control terminals (all enclosures)

### 4.1.18. How to Test Motor and Direction of Rotation.



Note that unintended motor start can occur, ensure no personnel or equipment is in danger!

Please follow these steps to test the motor connection and direction of rotation. Start with no power to the unit.

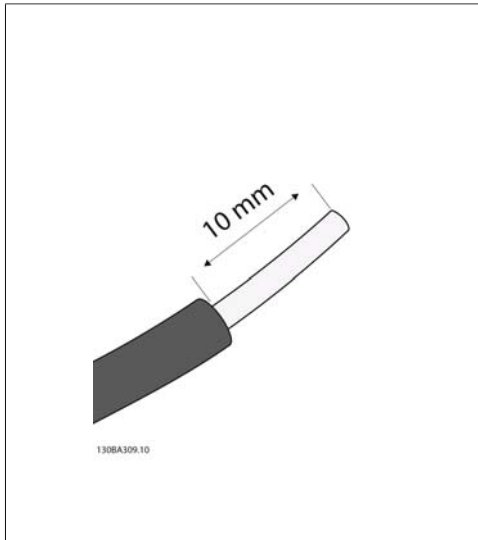

Illustration 4.19:  
**Step 1:** First remove the insulation on both ends of a 50 to 70 mm piece of wire.

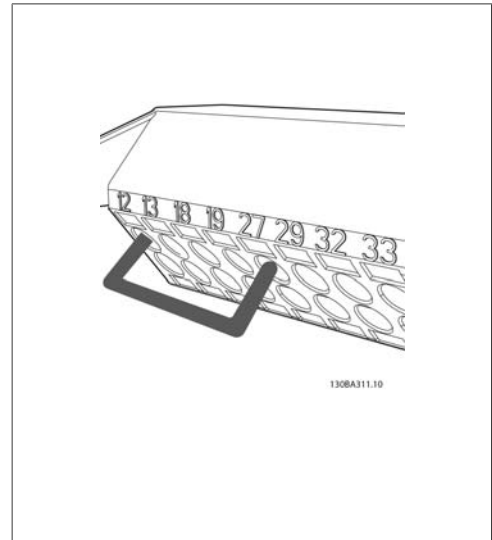

Illustration 4.21:  
**Step 3:** Insert the other end in terminal 12 or 13. (Note: For units with Safe Stop function, the existing jumper between terminal 12 and 37 should not be removed for the unit to be able to run!)

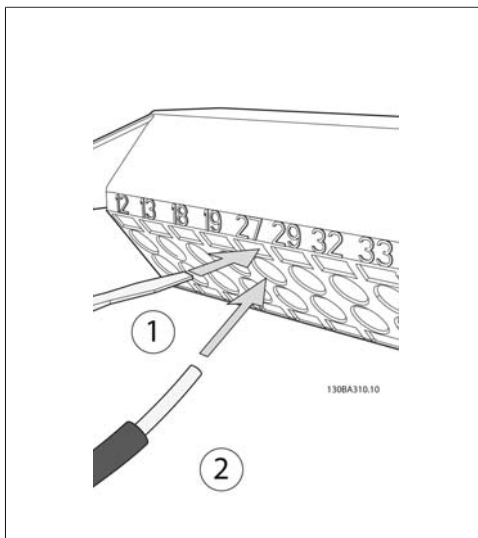

Illustration 4.20:  
**Step 2:** Insert one end in terminal 27 using a suitable terminal screwdriver. (Note: For units with Safe Stop function, the existing jumper between terminal 12 and 37 should not be removed for the unit to be able to run!)



Illustration 4.22:  
**Step 4:** Power-up the unit and press the [Off] button. In this state the motor should not rotate. Press [Off] to stop the motor at any time. Note the LED at the [OFF] button should be lit. If alarms or warnings are flashing, please see chapter 7 regarding these.

4



Illustration 4.23:

**Step 5:** By pressing the [Hand on] button, the LED above the button should be lit and the motor may rotate.



Illustration 4.26:

**Step 8:** Press the [Off] button to stop the motor again.

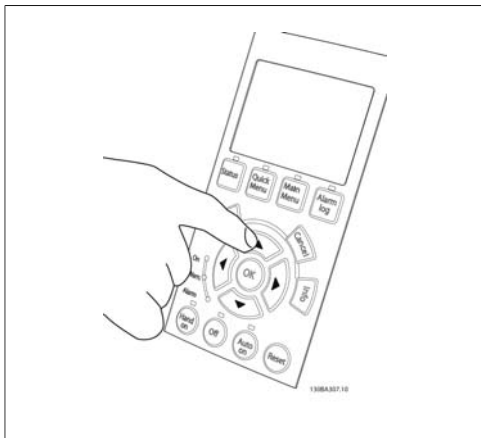

Illustration 4.24:

**Step 6:** The speed of the motor can be seen in the LCP. It can be adjusted by pushing the up ▲ and down ▼ arrow buttons.

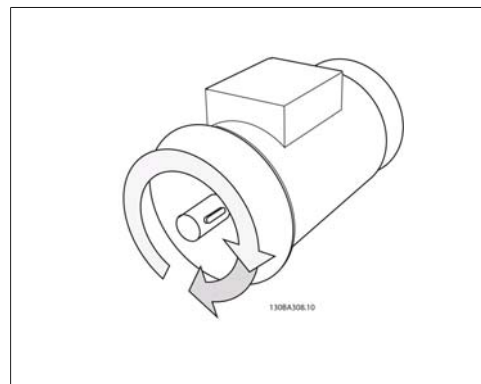

Illustration 4.27:

**Step 9:** Change two motor wires if the desired rotation of direction is not achieved.



Illustration 4.25:

**Step 7:** To move the cursor, use the left ◀ and right ▶ arrow buttons. This enables changing the speed in larger increments.

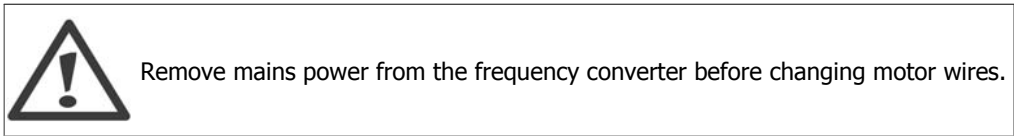

### 4.1.19. Electrical Installation and Control Cables

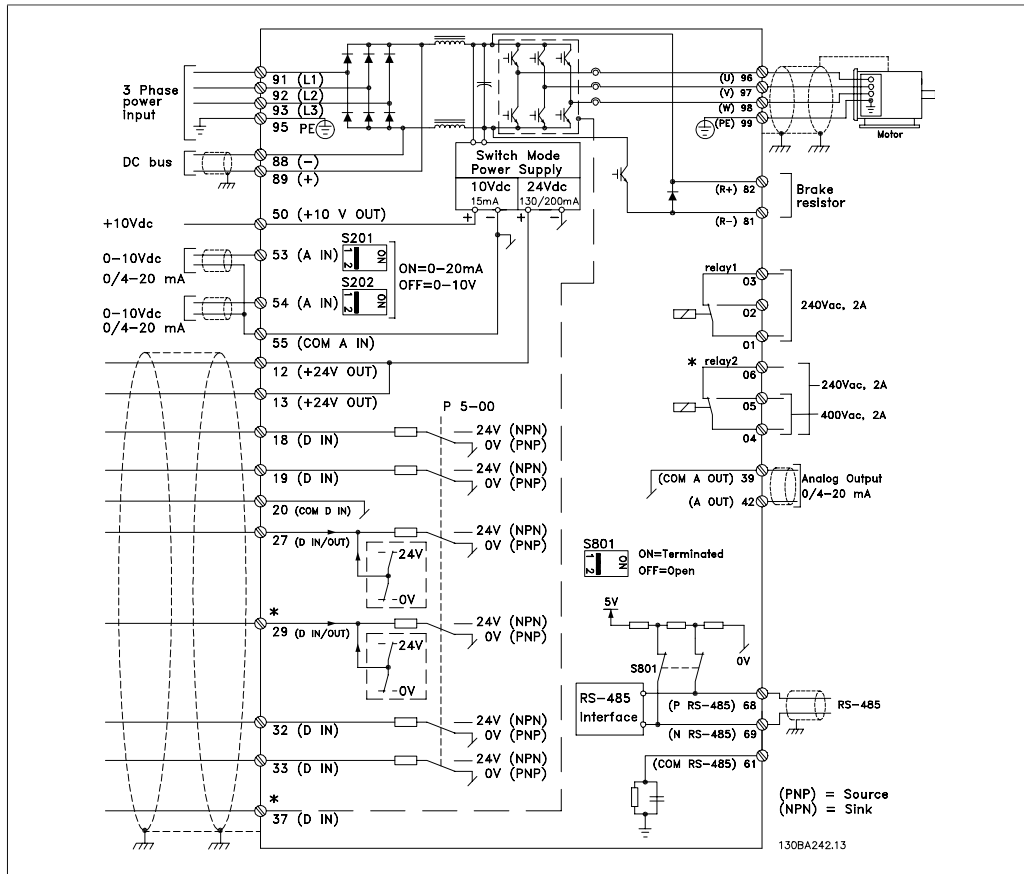

Illustration 4.28: Diagram showing all electrical terminals. (Terminal 37 present for units with Safe Stop function only.)

Very long control cables and analog signals may, in rare cases and depending on installation, result in 50/60 Hz earth loops due to noise from mains supply cables.

If this occurs, break the screen or insert a 100 nF capacitor between screen and chassis.

**NB!**  
Connect the common of digital and analog inputs and outputs to separate frequency converter common terminals 20, 39, and 55. This will avoid ground current interference among groups. For example, it avoids switching on digital inputs disturbing analog inputs.

**NB!**  
Control cables must be screened/armoured.

1. Use a clamp from the accessory bag to connect screen to frequency converter decoupling plate for control cables.

See section entitled *Earthing of Screened/Armoured Control Cables* for the correct termination of control cables.

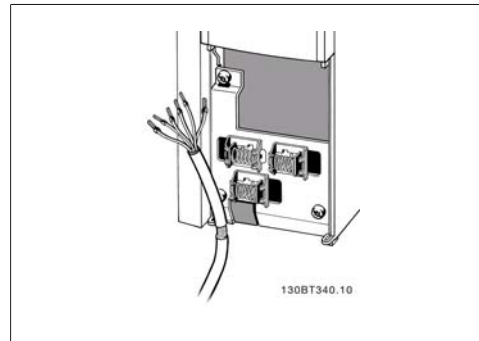

Illustration 4.29: Control cable clamp.

4

#### 4.1.20. Switches S201, S202, and S801

Switches S201 (AI53) and S202 (AI54) are used to select a current (0-20 mA) or a voltage (0 to 10 V) configuration of the analog input terminals 53 and 54 respectively.

Switch S801 (BUS TER.) can be used to enable termination on the RS-485 port (terminals 68 and 69).

Please note that the switches may be covered by an option, if fitted.

Default setting:

S201 (A53) = OFF (voltage input)

S202 (A54) = OFF (voltage input)

S801 (Bus termination) = OFF

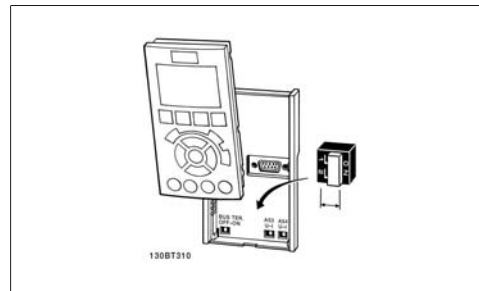



Illustration 4.30: Switches location.

## 4.2. Final optimization and test

### 4.2.1. Final optimization and test

To optimize motor shaft performance and optimize the frequency converter for the connected motor and installation, please follow these steps. Ensure that frequency converter and motor are connected, and power is applied to frequency converter.



**NB!**  
Before power up ensure that connected equipment is ready for use.

Step 1. Locate motor name plate..



**NB!**  
The motor is either star- (Y) or delta- connected ( $\Delta$ ). This information is located on the motor name plate data.

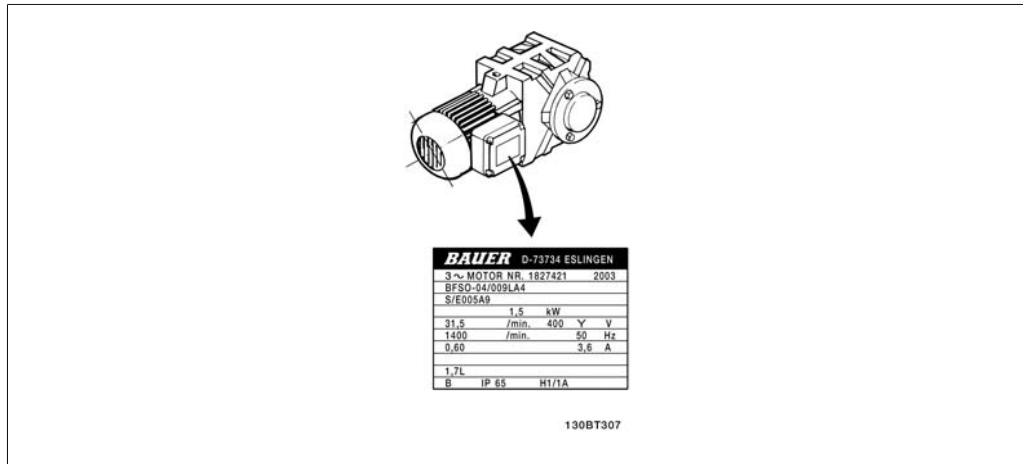

Illustration 4.31: Motor name plate example

### Step 2. Enter motor name plate data in following parameter list.

To access list first press [QUICK MENU] key then select "Q2 Quick Setup".

1.	Motor Power [kW] or Motor Power [HP]	par. 1-20 par. 1-21
2.	Motor Voltage	par. 1-22
3.	Motor Frequency	par. 1-23
4.	Motor Current	par. 1-24
5.	Motor Nominal Speed	par. 1-25

Table 4.8: Motor related parameters

### Step 3. Activate Automatic Motor Adaptation (AMA)

Performing AMA ensures best possible performance. AMA automatically takes measurements from the specific motor connected and compensates for installation variances.

1. Connect terminal 27 to terminal 12 or use [QUICK MENU] and "Q2 Quick Setup" and set Terminal 27 par. 5-12 to *No function* (par. 5-12 [0])
2. Press [QUICK MENU], select "Q3 Function Setups", select "Q3-1 General Settings", select "Q3-10 Adv. Motor Settings" and scroll down to AMA par. 1-29.
3. Press [OK] to activate the AMA par. 1-29.
4. Choose between complete or reduced AMA. If sine wave filter is mounted, run only reduced AMA, or remove sine wave filter during AMA procedure.
5. Press [OK] key. Display should show "Press [Hand on] to start".
6. Press [Hand on] key. A progress bar indicates if AMA is in progress.

#### Stop the AMA during operation

1. Press the [OFF] key - the frequency converter enters into alarm mode and the display shows that the AMA was terminated by the user.

#### Successful AMA

1. The display shows "Press [OK] to finish AMA".
2. Press the [OK] key to exit the AMA state.

**Unsuccessful AMA**

1. The frequency converter enters into alarm mode. A description of the alarm can be found in the *Troubleshooting* section.
2. "Report Value" in the [Alarm Log] shows the last measuring sequence carried out by the AMA, before the frequency converter entered alarm mode. This number along with the description of the alarm will assist troubleshooting. If contacting Danfoss Service, make sure to mention number and alarm description.

**NB!** Unsuccessful AMA is often caused by incorrectly entered motor name plate data or too big difference between the motor power size and the frequency converter power size.

**Step 4. Set speed limit and ramp time**

Set up the desired limits for speed and ramp time.

Minimum Reference	par. 3-02
Maximum Reference	par. 3-03

Motor Speed Low Limit	par. 4-11 or 4-12
Motor Speed High Limit	par. 4-13 or 4-14

Ramp-up Time 1 [s]	par. 3-41
Ramp-down Time 1 [s]	par. 3-42



## 5. How to operate the frequency converter

### 5.1. Three ways of operating

#### 5.1.1. Three ways of operating

The frequency converter can be operated in 3 ways:

1. Graphical Local Control Panel (GLCP), see 5.1.3
2. Numeric Local Control Panel (NLCP), see 5.1.2
3. RS-485 serial communication or USB, both for PC connection, see 5.1.4

If the frequency converter is fitted with fieldbus option, please refer to relevant documentation.

#### 5.1.2. How to operate graphical LCP (GLCP)

The following instructions are valid for the GLCP (LCP 102).

The GLCP is divided into four functional groups:

1. Graphical display with Status lines.
2. Menu keys and indicator lights (LED's) - selecting mode, changing parameters and switching between display functions.
3. Navigation keys and indicator lights (LEDs).
4. Operation keys and indicator lights (LEDs).

**Graphical display:**

The LCD-display is back-lit with a total of 6 alpha-numeric lines. All data is displayed on the LCP which can show up to five operating variables while in [Status] mode.

**Display lines:**

- a. **Status line:** Status messages displaying icons and graphics.
- b. **Line 1-2:** Operator data lines displaying data and variables defined or chosen by the user. By pressing the [Status] key, up to one extra line can be added.
- c. **Status line:** Status messages displaying text.

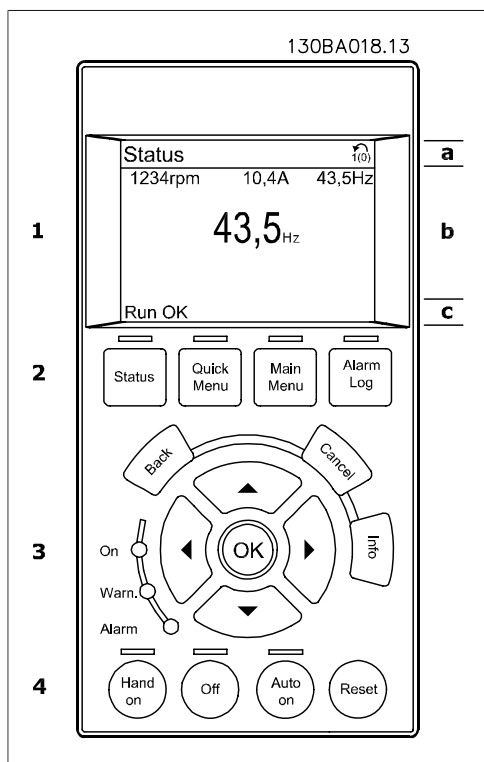

The display is divided into 3 sections:

**Top section(a)** shows the status when in status mode or up to 2 variables when not in status mode and in the case of Alarm/Warning.

The number of the Active Set-up (selected as the Active Set-up in par. 0-10) is shown. When programming in another Set-up than the Active Set-up, the number of the Set-up being programmed appears to the right in brackets.

The **Middle section(b)** shows up to 5 variables with related unit, regardless of status. In case of alarm/warning, the warning is shown instead of the variables.

It is possible to toggle between three status read-out displays by pressing the [Status] key. Operating variables with different formatting are shown in each status screen - see below.

Several values or measurements can be linked to each of the displayed operating variables. The values / measurements to be displayed can be defined via par. 0-20, 0-21, 0-22, 0-23, and 0-24, which can be accessed via [QUICK MENU], "Q3 Function Setups", "Q3-1 General Settings", "Q3-13 Display Settings".

Each value / measurement readout parameter selected in par. 0-20 to par. 0-24 has its own scale and number of digits after a possible decimal point. Larger numeric values are displayed with few digits after the decimal point.

Ex.: Current readout  
5.25 A; 15.2 A 105 A.

#### Status display I:

This read-out state is standard after start-up or initialization.

Use [INFO] to obtain information about the value/measurement linked to the displayed operating variables (1.1, 1.2, 1.3, 2, and 3).

See the operating variables shown in the display in this illustration. 1.1, 1.2 and 1.3 are shown in small size. 2 and 3 are shown in medium size.

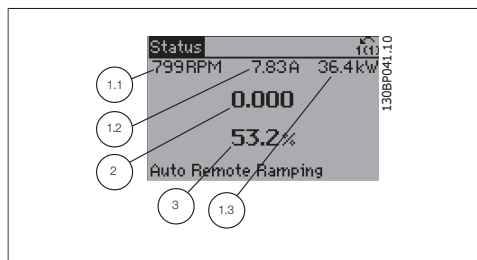

**Status display II:**

See the operating variables (1.1, 1.2, 1.3, and 2) shown in the display in this illustration.

In the example, Speed, Motor current, Motor power and Frequency are selected as variables in the first and second lines.

1.1, 1.2 and 1.3 are shown in small size. 2 is shown in large size.

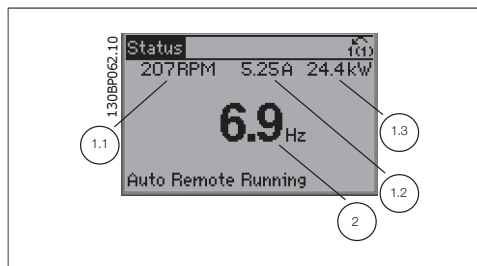

**Status display III:**

This state displays the event and action of the Smart Logic Control. For further information, see section *Smart Logic Control*.

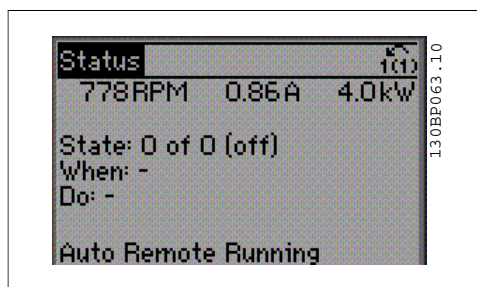

The **Bottom section** always shows the state of the frequency converter in Status mode.

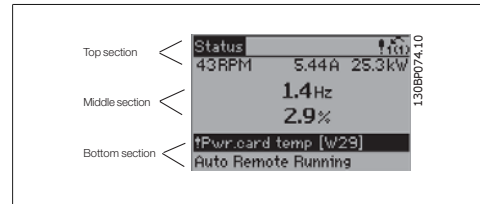

### Display Contrast Adjustment

Press [status] and [▲] for darker display  
Press [status] and [▼] for brighter display

### Indicator lights (LEDs):

If certain threshold values are exceeded, the alarm and/or warning LED lights up. A status and alarm text appear on the control panel.

The On LED is activated when the frequency converter receives power from mains voltage, a DC bus terminal, or an external 24 V supply. At the same time, the back light is on.

- Green LED/On: Control section is working.
- Yellow LED/Warn.: Indicates a warning.
- Flashing Red LED/Alarm: Indicates an alarm.

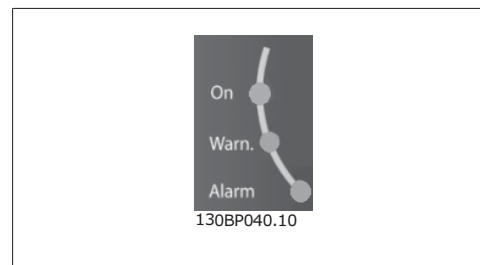

### GLCP keys

#### Menu keys

The menu keys are divided into functions. The keys below the display and indicator lamps are used for parameter set-up, including choice of display indication during normal operation.

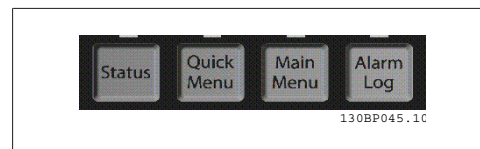

#### [Status]

indicates the status of the frequency converter and/or the motor. 3 different readouts can be chosen by pressing the [Status] key:

5 line readouts, 4 line readouts or Smart Logic Control.

Use [Status] for selecting the mode of display or for changing back to Display mode from either the Quick Menu mode, the Main Menu mode or Alarm mode. Also use the [Status] key to toggle single or double read-out mode.

#### [Quick Menu]

allows quick set-up of the frequency converter. **The most common HVAC functions can be programmed here.**

The [Quick Menu] consists of:

- **My Personal Menu**
- **Quick Set-up**
- **Function set-up**
- **Changes Made**
- **Loggings**

The Function set-up provides quick and easy access to all parameters required for the majority of HVAC applications including most VAV and CAV supply and return fans, cooling tower fans, Primary, Secondary and Condenser Water Pumps and other pump, fan and compressor applications. Amongst other features it also includes parameters for selecting which variables to display on the LCP, digital preset speeds, scaling of analog references, closed loop single zone and multi-zone applications and specific functions related to Fans, Pumps and Compressors.

The Quick Menu parameters can be accessed immediately unless a password has been created via par. 0-60, 0-61, 0-65 or 0-66.

It is possible to switch directly between Quick Menu mode and Main Menu mode.

#### [Main Menu]

is used for programming all parameters.

The Main Menu parameters can be accessed immediately unless a password has been created via par. 0-60, 0-61, 0-65 or 0-66. For the majority of HVAC applications it is not necessary to access the Main Menu parameters but instead the Quick Menu, Quick Set-up and Function Set-up provides the simplest and quickest access to the typical required parameters.

It is possible to switch directly between Main Menu mode and Quick Menu mode.

Parameter shortcut can be carried out by pressing down the [Main Menu] key for 3 seconds. The parameter shortcut allows direct access to any parameter.

#### [Alarm Log]

displays an Alarm list of the five latest alarms (numbered A1-A5). To obtain additional details about an alarm, use the arrow keys to manoeuvre to the alarm number and press [OK]. Information is displayed about the condition of the frequency converter before it enters the alarm mode.

#### [Back]

reverts to the previous step or layer in the navigation structure.

#### [Cancel]

last change or command will be cancelled as long as the display has not been changed.

#### [Info]

displays information about a command, parameter, or function in any display window. [Info] provides detailed information when needed.

Exit Info mode by pressing either [Info], [Back], or [Cancel].

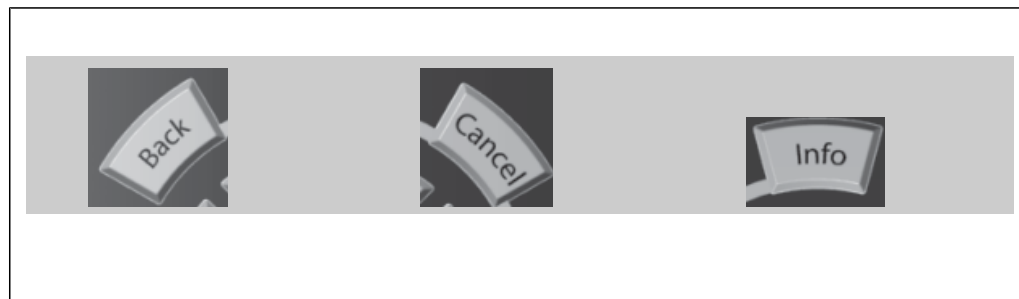

**Navigation Keys**

The four navigation arrows are used to navigate between the different choices available in [Quick Menu], [Main Menu] and [Alarm Log]. Use the keys to move the cursor.

[OK] is used for choosing a parameter marked by the cursor and for enabling the change of a parameter.

**Operation Keys** for local control are found at the bottom of the control panel.

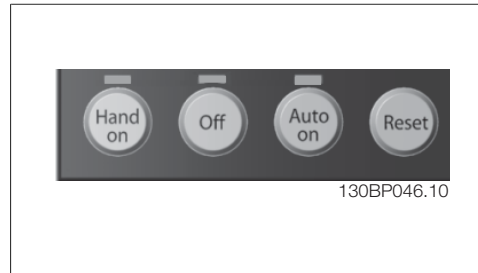
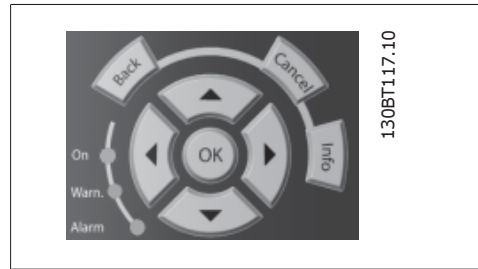
**[Hand On]**

enables control of the frequency converter via the GLCP. [Hand on] also starts the motor, and it is now possible to enter the motor speed data by means of the arrow keys. The key can be selected as *Enable* [1] or *Disable* [0] via par. 0-40 [Hand on] key on LCP.

The following control signals will still be active when [Hand on] is activated:

- [Hand on] - [Off] - [Auto on]
- Reset
- Coasting stop inverse
- Reversing
- Set-up select lsb - Set-up select msb
- Stop command from serial communication
- Quick stop
- DC brake

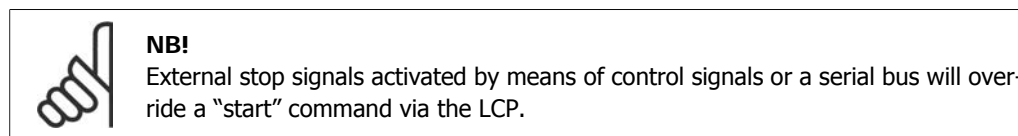
**[Off]**

stops the connected motor. The key can be selected as *Enable* [1] or *Disable* [0] via par. 0-41 [Off] key on LCP. If no external stop function is selected and the [Off] key is inactive the motor can only be stopped by disconnecting the mains supply.

**[Auto On]**

enables the frequency converter to be controlled via the control terminals and/or serial communication. When a start signal is applied on the control terminals and/or the bus, the frequency converter will start. The key can be selected as *Enable* [1] or *Disable* [0] via par. 0-42 [Auto on] key on LCP.

**NB!**

An active HAND-OFF-AUTO signal via the digital inputs has higher priority than the control keys [Hand on] – [Auto on].

**[Reset]**

is used for resetting the frequency converter after an alarm (trip). It can be selected as *Enable* [1] or *Disable* [0] via par. 0-43 *Reset Keys on LCP*.

The **parameter shortcut** can be carried out by holding down the [Main Menu] key for 3 seconds. The parameter shortcut allows direct access to any parameter.

### 5.1.3. How to operate numeric LCP (NLCP)

The following instructions are valid for the NLCP (LCP 101).

The control panel is divided into four functional groups:

1. Numeric display.
2. Menu key and indicator lights (LEDs) - changing parameters and switching between display functions.
3. Navigation keys and indicator lights (LEDs).
4. Operation keys and indicator lights (LEDs).

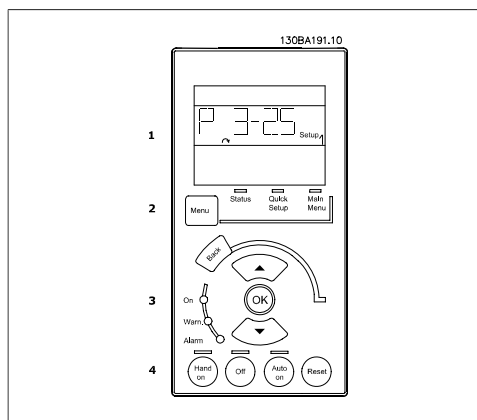

Illustration 5.1: Numerical LCP (NLCP)

**NB!**

Parameter copy is not possible with Numeric Local Control Panel (LCP101).

**Select one of the following modes:**

**Status Mode:** Displays the status of the frequency converter or the motor.

If an alarm occurs, the NLCP automatically switches to status mode.

A number of alarms can be displayed.

**Quick Setup or Main Menu Mode:** Display parameters and parameter settings.

**Indicator lights (LEDs):**

- Green LED/On: Indicates if control section is on.
- Yellow LED/Wrn.: Indicates a warning.
- Flashing red LED/Alarm: Indicates an alarm.

**Main Menu** is used for programming all parameters.

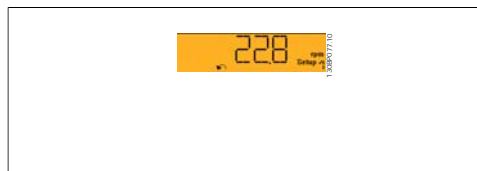

Illustration 5.2: Status display example

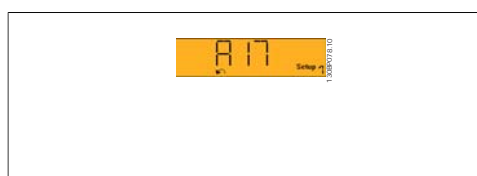

Illustration 5.3: Alarm display example

**Menu key**

**[Menu]** Select one of the following modes:

- Status
- Quick Setup
- Main Menu

The parameters can be accessed immediately unless a password has been created via par. 0-60, 0-61, 0-65 or 0-66.

**Quick Setup** is used to set up the frequency converter using only the most essential parameters. The parameter values can be changed using the up/down arrows when the value is flashing. Select Main Menu by pressing the [Menu] key a number of times until the Main Menu LED is lit. Select the parameter group [xx-\_\_] and press [OK] Select the parameter [\_\_-xx] and press [OK] If the parameter is an array parameter select the array number and press [OK] Select the wanted data value and press [OK]

**Navigation Keys [Back]** for stepping backwards

**Arrow [▲] [▼]** keys are used for manoeuvring between parameter groups, parameters and within parameters.

**[OK]** is used for choosing a parameter marked by the cursor and for enabling the change of a parameter.

5

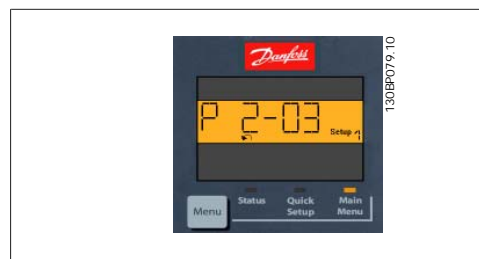

Illustration 5.4: Display example

#### Operation Keys

Keys for local control are found at the bottom of the control panel.

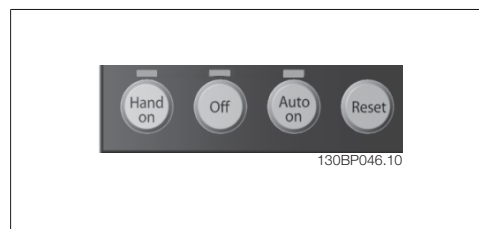

Illustration 5.5: Operation keys of the numerical CP (NLCP)

**[Hand on]** enables control of the frequency converter via the LCP. [Hand on] also starts the motor and it is now possible to enter the motor speed data by means of the arrow keys. The key can be selected as *Enable* [1] or *Disable* [0] via par. 0-40 *[Hand on] Key on LCP*.



External stop signals activated by means of control signals or a serial bus will override a 'start' command via the LCP.

The following control signals will still be active when [Hand on] is activated:

- [Hand on] - [Off] - [Auto on]
- Reset
- Coasting stop inverse
- Reversing
- Set-up select lsb - Set-up select msb
- Stop command from serial communication
- Quick stop
- DC brake

[Off] stops the connected motor. The key can be selected as *Enable* [1] or *Disable* [0] via par. 0-41 [Off] Key on LCP.

If no external stop function is selected and the [Off] key is inactive the motor can be stopped by disconnecting the mains supply.

[Auto on] enables the frequency converter to be controlled via the control terminals and/or serial communication. When a start signal is applied on the control terminals and/or the bus, the frequency converter will start. The key can be selected as *Enable* [1] or *Disable* [0] via par. 0-42 [Auto on] Key on LCP.



**NB!**

An active HAND-OFF-AUTO signal via the digital inputs has higher priority than the control keys [Hand on] [Auto on].

[Reset] is used for resetting the frequency converter after an alarm (trip). It can be selected as *Enable* [1] or *Disable* [0] via par. 0-43 Reset Keys on LCP.

### 5.1.4. RS-485 Bus Connection

One or more frequency converters can be connected to a controller (or master) using the RS-485 standard interface. Terminal 68 is connected to the P signal (TX+, RX+), while terminal 69 is connected to the N signal (TX-, RX-).

If more than one frequency converter is connected to a master, use parallel connections.

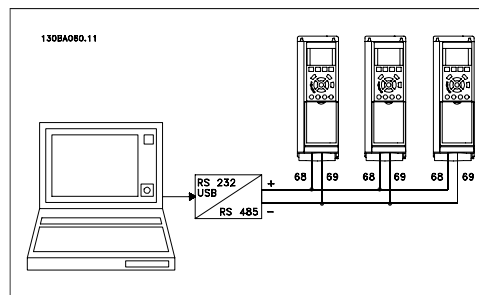

Illustration 5.6: Connection example.

In order to avoid potential equalizing currents in the screen, earth the cable screen via terminal 61, which is connected to the frame via an RC-link.

#### Bus termination

The RS-485 bus must be terminated by a resistor network at both ends. For this purpose, set switch S801 on the control card for ON.

For more information, see the paragraph *Switches S201, S202, and S801*.

### 5.1.5. How to Connect a PC to the FC 100

To control or program the frequency converter from a PC, install the MCT 10 Set-up Software. The PC is connected via a standard (host/device) USB cable, or via the RS-485 interface as shown in the FC 100 Design Guide chapter **How to Install > Installation of misc. connections.**



**NB!**

The USB connection is galvanically isolated from the supply voltage (PELV) and other high-voltage terminals. The USB connection is connected to protection earth on the frequency converter. Use only isolated laptop as PC connection to the USB connector on the VLT HVAC Drive.

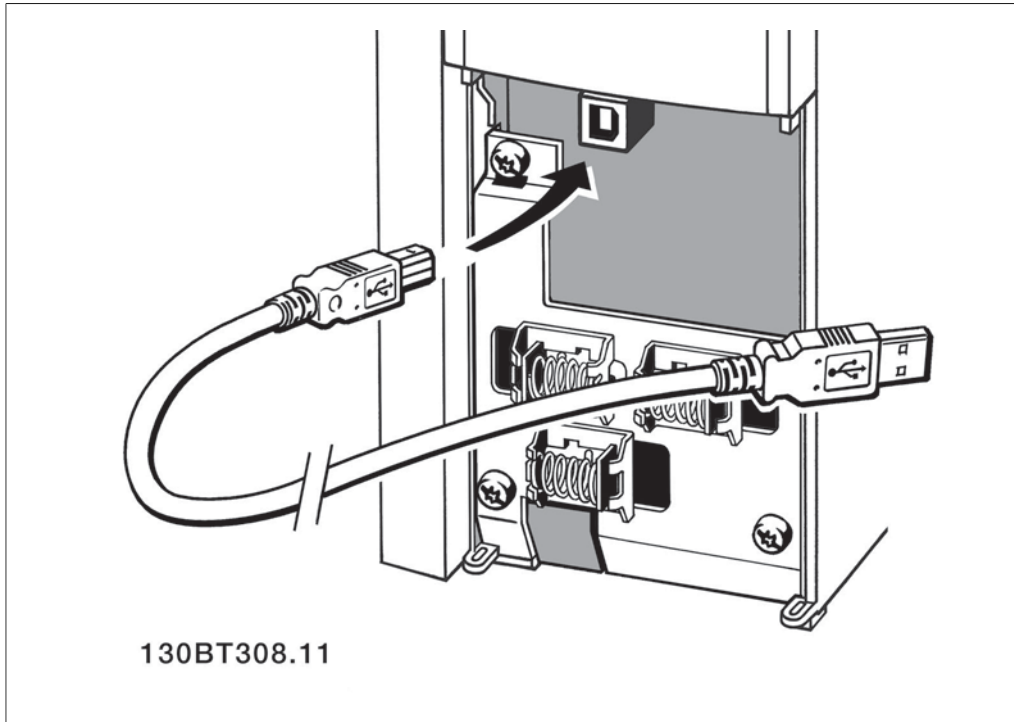

### 5.1.6. PC Software tools

**PC Software - MCT 10**

All Frequency converters are equipped with a serial communication port. Danfoss provides a PC tool for communication between PC and frequency converter, VLT Motion Control Tool MCT 10 Set-up Software.

**MCT 10 Set-up Software**

MCT 10 has been designed as an easy to use interactive tool for setting parameters in our frequency converters. The software can be downloaded from the Danfoss internet site <http://www.vlt-software.com>.

The MCT 10 Set-up Software will be useful for:

- Planning a communication network off-line. MCT 10 contains a complete frequency converter database
- Commissioning frequency converters on line
- Saving settings for all frequency converters
- Replacing a frequency converter in a network

- Simple and accurate documentation of frequency converter settings after commissioning.
- Expanding an existing network
- Future developed frequency converters will be supported

MCT 10 Set-up Software supports Profibus DP-V1 via a Master class 2 connection. It makes it possible to on line read/write parameters in a frequency converter via the Profibus network. This will eliminate the need for an extra communication network.

#### Save Frequency Converter Settings:

1. Connect a PC to the unit via USB com port. (Note: Use a PC, which is isolated from the mains, in conjunction with the USB port. Failure to do so may damage equipment.)
2. Open MCT 10 Set-up Software
3. Choose "Read from drive"
4. Choose "Save as"

All parameters are now stored in the PC.

#### Load Frequency Converter Settings:

1. Connect a PC to the frequency converter via USB com port
2. Open MCT 10 Set-up software
3. Choose "Open"– stored files will be shown
4. Open the appropriate file
5. Choose "Write to drive"

All parameter settings are now transferred to the frequency converter.

A separate manual for MCT 10 Set-up Software is available: **MG.10.R2.02**.

#### The MCT 10 Set-up Software Modules

The following modules are included in the software package:

	<p><b>MCT 10 Set-up Software</b>          Setting parameters          Copy to and from frequency converters          Documentation and print out of parameter settings incl. diagrams</p>
<hr/>	
<p><b>Ext. User Interface</b>          Preventive Maintenance Schedule          Clock settings          Timed Action Programming          Smart Logic Controller Set-up</p>	

#### Ordering number:

Please order the CD containing MCT 10 Set-up Software using code number 130B1000.

MCT 10 can also be downloaded from the Danfoss Internet: [WWW.DANFOSS.COM](http://WWW.DANFOSS.COM), Business Area: Motion Controls.

### 5.1.7. Tips and tricks

- |   |  |
|---|--|
| * | For the majority of HVAC applications the Quick Menu, Quick Set-up and Function Set-up provides the simplest and quickest access to all the typical parameters required. |
| * | Whenever possible, performing an AMA, will ensure best shaft performance   |
| * | Contrast of the display can be adjusted by pressing [Status] and [▲] for darker display or by pressing [Status] and [▼] for brighter display                             |
| * | Under [Quick Menu] and [Changes Made] all parameters that have been changed from factory settings are displayed  |
| * | Press and hold [Main Menu] key for 3 seconds for access to any parameter   |
| * | For service purposes it is recommended to copy all parameters to the LCP, see par 0-50 for further information   |

Table 5.1: Tips and tricks

### 5.1.8. Quick Transfer of Parameter Settings when using GLCP

Once the set-up of a frequency converter is complete, it is recommended to store (backup) the parameter settings in the GLCP or on a PC via MCT 10 Set-up Software Tool.



**NB!**

Stop the motor before performing any of these operations.

**Data storage in LCP:**

1. Go to par. 0-50 *LCP Copy*
2. Press the [OK] key
3. Select "All to LCP"
4. Press the [OK] key

All parameter settings are now stored in the GLCP indicated by the progress bar. When 100% is reached, press [OK].

The GLCP can now be connected to another frequency converter and the parameter settings copied to this frequency converter.

**Data transfer from LCP to Frequency converter:**

1. Go to par. 0-50 *LCP Copy*
2. Press the [OK] key
3. Select "All from LCP"
4. Press the [OK] key

The parameter settings stored in the GLCP are now transferred to the frequency converter indicated by the progress bar. When 100% is reached, press [OK].

### 5.1.9. Initialisation to Default Settings

Initialise the frequency converter to default settings in two ways:

#### Recommended initialisation (via par. 14-22)

1. Select par. 14-22
2. Press [OK]
3. Select "Initialisation" ( for NLCP select "2" )
4. Press [OK]
5. Remove power to unit and wait for display to turn off.
6. Reconnect power and the frequency converter is reset. Note that first start-up takes a few more seconds.

Par. 14-22 initialises all except:

14-50	<i>RFI 1</i>
8-30	<i>Protocol</i>
8-31	<i>Address</i>
8-32	<i>Baud Rate</i>
8-35	<i>Minimum Response Delay</i>
8-36	<i>Max Response Delay</i>
8-37	<i>Max Inter-char Delay</i>
15-00 to 15-05	Operating data
15-20 to 15-22	Historic log
15-30 to 15-32	Fault log



#### NB!

Parameters selected in *Personal Menu*, will stay present, with default factory setting.

#### Manual initialisation



#### NB!

When carrying out manual initialisation, serial communication, RFI filter settings (par. 14-50) and fault log settings are reset.  
Removes parameters selected in *Personal Menu*.

1. Disconnect from mains and wait until the display turns off.
- 2a. Press [Status] - [Main Menu] - [OK] at the same time while power up for Graphical LCP (GLCP).
- 2b. Press [Menu] while power up for LCP 101, Numerical Display
3. Release the keys after 5 s.
4. The frequency converter is now programmed according to default settings.

This parameter initialises all except:

15-00	<i>Operating Hours</i>
15-03	<i>Power-up's</i>
15-04	<i>Over temp's</i>
15-05	<i>Over volt's</i>



## 6. How to programme the frequency converter

### 6.1. How to programme

#### 6.1.1. Parameter Set-Up

Group	Title	Function
0-	Operation / Display	Parameters related to the fundamental functions of the frequency converter, function of the LCP buttons and configuration of the LCP display.
1-	Load / Motor	Parameter group for motor settings.
2-	Brakes	Parameter group for setting brake features in the frequency converter.
3-	Reference / Ramps	Parameters for reference handling, definitions of limitations, and configuration of the reaction of the frequency converter to changes.
4-	Limits / Warnings	Parameter group for configuring limits and warnings.
5-	Digital in/out	Parameter group for configuring the digital inputs and outputs.
6-	Analog in/out	Parameter group for configuration of the analog inputs and outputs.
8-	Communication and options	Parameter group for configuring communications and options.
9-	Profibus	Parameter group for Profibus-specific parameters.
11-	LonWorks	Parameter group for LonWorks parameters
13-	Smart logic	Parameter group for Smart Logic Control
14-	Special functions	Parameter group for configuring special frequency converter functions.
15-	Drive information	Parameter group containing frequency converter information such as operating data, hardware configuration and software versions.
16-	Data readouts	Parameter group for data read-outs, e.g. actual references, voltages, control, alarm, warning and status words.
18-	Maintenance log	This parameter group contains the last 10 Preventive Maintenance logs.
20-	Drive closed loop	This parameter group is used for configuring the closed loop PID Controller that controls the output frequency of the unit.
21-	Extended closed loop	Parameters for configuring the three Extended Closed Loop PID Controllers.
22-	Application functions	These parameters monitor HVAC applications.
23-	Time-based functions	These parameters are for actions needed to be performed on a daily or weekly basis, e.g. different references for working hours/non-working hours.
25-	Cascade controller functions	Parameters for configuring the Basic Cascade Controller for sequence control of multiple pumps.

Table 6.1: Parameter Groups

Parameter descriptions and selections are displayed on the graphic (GLCP) or numeric (NLCP) in the display area. (See Section 5 for details.) Access the parameters by pressing the [Quick Menu] or [Main Menu] key on the control panel. The quick menu is used primarily for commissioning the unit at start-up by providing those parameters necessary to start operation. The main menu provides access to all parameters for detailed application programming.

All digital input/output and analog input/output terminals are multifunctional. All terminals have factory default functions suitable for the majority of HVAC applications but if other special functions are required, they must be programmed in parameter group 5 or 6.

### 6.1.2. Quick Menu Mode

The GLCP provides access to all parameters listed under the Quick Menu. The NLCP only provides access to the Quick Setup parameters. To set parameters using the [Quick Menu] button:

Pressing [Quick Menu] the list indicates the different areas contained in the Quick menu.

#### Efficient Parameter Set-up for HVAC Applications

The parameters can easily be set up for the vast majority of the HVAC applications only by using the [Quick Menu].

The optimum way to set parameters through the [Quick Menu] is by following the below steps:

1. Press [Quick Setup] for selecting basic motor settings, ramp times, etc.
2. Press [Function Setups] for setting up the required functionality of the frequency converter - if not already covered by the settings in [Quick Setup].
3. Choose between *General Settings*, *Open Loop Settings*, *Closed Loop Settings* or *Application Settings*.

It is recommended to do the set-up in the order listed.

Select *My Personal Menu* to display only the parameters, which have been pre-selected and programmed as personal parameters. For example, an AHU or pump OEM may have pre-programmed these to be in My Personal Menu during factory commissioning to make on site commissioning / fine tuning simpler.. These parameters are selected in parameter 0-25 *Personal Menu*. Up to 20 different parameters can be defined in this menu.

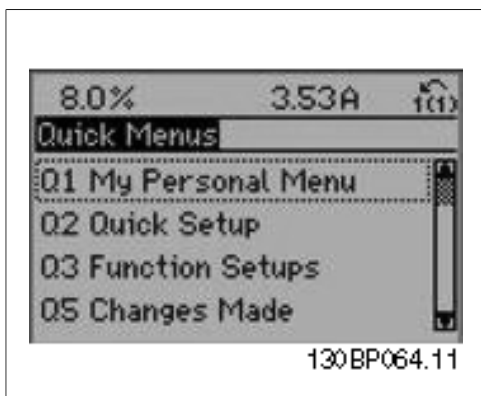

Illustration 6.1: Quick menu view.

Par.	Designation	[Units]
0-01	Language	
1-20	Motor Power	[kW]
1-21	Motor Power*	[HP]
1-22	Motor Voltage	[V]
1-23	Motor Frequency	[Hz]
1-24	Motor Current	[A]
1-25	Motor Nominal Speed	[RPM]
3-41	Ramp 1 Ramp up Time	[s]
3-42	Ramp 1 Ramp down Time	[s]
4-11	Motor Speed Low Limit	[RPM]
4-12	Motor Speed Low Limit*	[Hz]
4-13	Motor Speed High Limit	[RPM]
4-14	Motor Speed High Limit*	[Hz]
3-11	Jog Speed*	[Hz]
5-12	Terminal 27 Digital Input	
5-40	Function Relay	

Table 6.2: Quick Setup parameters



\*The display showing depends on choices made in parameter 0-02 and 0-03. The default setting of parameters 0-02 and 0-03 depends on which region of the world the frequency converter is supplied to but can be re-programmed as required.

If *No Operation* is selected in terminal 27 no connection to +24 V on terminal 27 is necessary to enable start.

If *Coast Inverse* (factory default value) is selected in Terminal 27, a connection to +24V is necessary to enable start.

Select *Changes made* to get information about:

- the last 10 changes. Use the up/down navigation keys to scroll between the last 10 changed parameters.
- the changes made since default setting.

Select *Loggings* to get information about the display line read-outs. The information is shown as graphs.

Only display parameters selected in par. 0-20 and par. 0-24 can be viewed. It is possible to store up to 120 samples in the memory for later reference.

0-01	Language
<b>Value:</b>	
* English (English)	[0]

1-20	Motor power parameter
<b>Value:</b>	
0.09 - 500 kW	* Size related
<b>Function:</b>	

Enter the nominal motor power in kW according to the motor nameplate data. The default value corresponds to the nominal rated output of the unit.

This parameter cannot be adjusted while the motor is running.

1-21	Motor Power [HP]
<b>Value:</b>	
1.5 - 55 HP	* Size related
<b>Function:</b>	

Enter the nominal motor power in HP according to the motor nameplate data. The default value corresponds to the nominal rated output of the unit.

This parameter cannot be adjusted while the motor is running.

1-22	Motor Voltage
<b>Value:</b>	
10 - 1000 V	* Size related
<b>Function:</b>	

Enter the nominal motor voltage according to the motor nameplate data. The default value corresponds to the nominal rated output of the unit.

This parameter cannot be adjusted while the motor is running.

1-23	Motor Frequency
<b>Value:</b>	
20 - 1000 Hz	* Size related
<b>Function:</b>	

Select the motor frequency value from the motor nameplate data. For 87 Hz operation with 230/400 V motors, set the nameplate data for 230 V/50 Hz. Adapt par. 4-13 *Motor Speed High Limit [RPM]* and par. 3-03 *Maximum Reference* to the 87 Hz application.

This parameter cannot be adjusted while the motor is running.

**1-24 Motor Current**  
**Value:**  
 0.1 - 10,000 A \* Size related  
**Function:**  
 Enter the nominal motor current value from the motor nameplate data. This data is used for calculating motor torque, motor thermal protection etc.  
 This parameter cannot be adjusted while the motor is running.

**1-25 Motor Nominal Speed**  
**Value:**  
 100 - 60,000 RPM \* Size related  
**Function:**  
 Enter the nominal motor speed value from the motor nameplate data. This data is used for calculating automatic motor compensations.  
 This parameter cannot be adjusted while the motor is running.

**3-41 Ramp 1 Ramp up Time**  
**Value:**  
 1 - 3600 s \* 3 s  
**Function:**  
 Enter the ramp-up time, i.e. the acceleration time from 0 RPM to the rated motor speed  $n_{M,N}$  (par. 1-25). Choose a ramp-up time such that the output current does not exceed the current limit in par. 4-18 during ramping. See ramp-down time in par. 3-42.

$$par.3 - 41 = \frac{t_{acc} \times n_{norm}[par.1 - 25]}{\Delta ref[rpm]} [s]$$

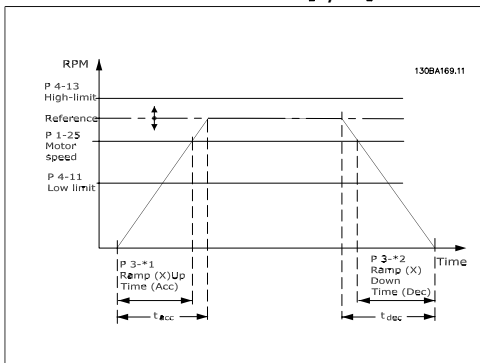

**3-42 Ramp 1 Ramp Down Time**  
**Value:**  
 1 - 3600 s \* 3 s  
**Function:**  
 Enter the ramp-down time, i.e. the deceleration time from the rated motor speed  $n_{M,N}$  (par. 1-25) to 0 RPM. Choose a ramp-down time such that no over-voltage arises in the inverter due to regenerative operation of the motor, and such that the generated current does not exceed the current limit set in par. 4-18. See ramp-up time in par. 3-41.

$$par.3 - 42 = \frac{t_{dec} \times n_{norm} [par.1 - 25]}{\Delta ref[rpm]} [s]$$

**4-11 Motor Speed Low Limit [RPM]**  
**Value:**  
 0 - 60,000 RPM \* Size related  
**Function:**  
 Enter the minimum limit for motor speed. The Motor Speed Low Limit can be set to correspond to the manufacturer's recommended minimum motor speed. The Motor Speed Low Limit must not exceed the setting in par. 4-13 *Motor Speed High Limit [RPM]*.

**4-12 Motor Speed Low Limit [Hz]**  
**Value:**  
 0 - 1000 Hz \* Size related  
**Function:**  
 Enter the minimum limit for motor speed. The Motor Speed Low Limit can be set to correspond to the minimum output frequency of the motor shaft. The Motor Speed Low Limit must not exceed the setting in par. 4-14 *Motor Speed High Limit [Hz]*.

#### 4-13 Motor Speed High Limit [RPM]

##### Value:

0 - 60,000 RPM \* Size related

##### Function:

Enter the maximum limit for motor speed. The Motor Speed High Limit can be set to correspond to the manufacturer's maximum rated motor speed. The Motor Speed High Limit must exceed the setting in par. 4-11 *Motor Speed Low Limit [RPM]*. Only par. 4-11 or 4-12 will be displayed depending on other parameters set in the Main Menu and depending on default settings dependant on global geographical location.



##### NB!

The output frequency value of the frequency converter must not exceed a value higher than 1/10 of the switching frequency.

#### 4-14 Motor Speed High Limit [Hz]

##### Value:

0 - 1000 Hz \* Size related

##### Function:

Enter the maximum limit for motor speed. The Motor Speed High Limit can be set to correspond to the manufacturer's recommended maximum frequency of the motor shaft. The Motor Speed High Limit must exceed the setting in par. 4-12 *Motor Speed Low Limit [Hz]*. Only par. 4-11 or 4-12 will be displayed depending on other parameters set in the Main Menu and depending on default settings dependant on global geographical location.



##### NB!

Max. output frequency cannot exceed 10% of the inverter switching frequency (par. 14-01).

#### 3-11 Jog Speed [Hz]

##### Value:

0 - 1000 Hz \* Size related

##### Function:

The jog speed is a fixed output speed at which the frequency converter is running when the jog function is activated.

See also par. 3-80.

### 6.1.3. Function Setups

The Function set-up provides quick and easy access to all parameters required for the majority of water and wastewater applications including variable torque, constant torque, pumps, dossoing pumps, well pumps, booster pumps, mixer pumps, aeration blowers and other pump and fan applications. Amongst other features it also includes parameters for selecting which variables to display on the LCP, digital preset speeds, scaling of analog references, closed loop single zone and multi-zone applications and specific functions related to Fans, Pumps and Compressors.

#### How to access Function Set-up - example

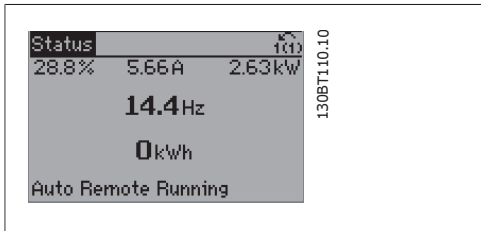

Illustration 6.2: Step 1: Turn on the frequency converter (open LED lights)

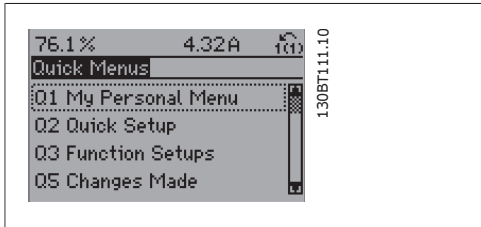

Illustration 6.3: Step 2: Press the [Quick Menus] button (Quick Menu choices appear).

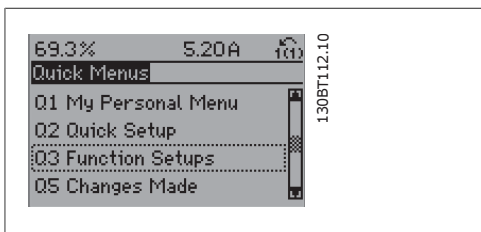

Illustration 6.4: Step 3: Use the up/down navigation keys to scroll down to Function Setups. Press [OK].

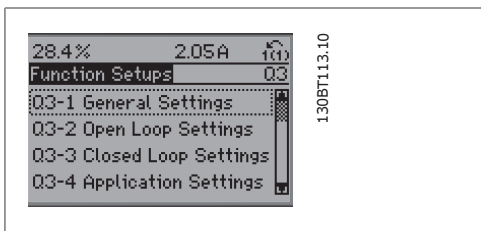

Illustration 6.5: Step 4: Function Setups choices appear. Choose Q3-1 *General Settings*. Press [OK].

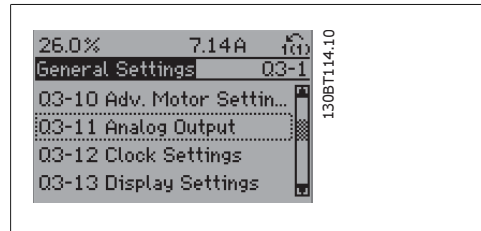

Illustration 6.6: Step 5: Use the up/down navigation keys to scroll down to i.e. Q3-11 *Analog Outputs*. Press [OK].

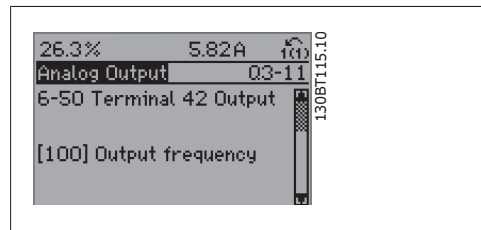

Illustration 6.7: Step 6: Choose parameter 6-50 *Terminal 42 Output*. Press [OK].

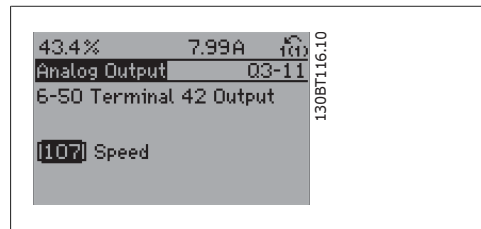

Illustration 6.8: Step 7: Use the up/down navigation keys to select between the different choices. Press [OK].

The Function Setup parameters are grouped in the following way:

Q3-1 General Settings			
Q3-10 Adv. Motor Settings	Q3-11 Analog Output	Q3-12 Clock Settings	Q3-13 Display Settings
1-90 Motor Thermal Protection	6-50 Terminal 42 Output	0-70 Set date and time	0-20 Display Line 1.1 Small
1-93 Thermistor Source	6-51 Terminal 42 Output max. scale	0-71 Date format	0-21 Display Line 1.2 Small
1-29 Automatic Motor Adaption	6-52 Terminal 42 Output min. scale	0-72 Time format	0-22 Display Line 1.3 Small
14-01 Switching Frequency		0-74 DST/Summertime	0-23 Display Line 2 large
		0-76 DST/Summertime start	0-24 Display Line 3 large
		0-77 DST/Summertime end	0-37 Display Text 1
			0-38 Display Text 2
			0-39 Display Text 3

Q3-2 Open Loop Settings	
Q3-20 Digital Reference	Q3-21 Analog Reference
3-02 Minimum reference	3-02 Minimum reference
3-03 Maximum reference	3-03 Maximum reference
3-10 Preset reference	6-10 Terminal 53 low voltage
5-13 Terminal 29 digital input	6-11 Terminal 53 high voltage
5-14 Terminal 32 digital input	6-14 Terminal 53 low ref/feedb. value
5-15 Terminal 33 digital input	6-15 Terminal 53 high ref/feedb. value

Q3-3 Closed Loop Settings		
Q3-30 Single Zone Int. S.	Q3-31 Single Zone Ext. S	Q3-32 Multi Zone / Adv.
1-00 Configuration mode	1-00 Configuration mode	1-00 Configuration mode
20-12 Reference/feedb unit	20-12 Reference/feedback	20-12 Reference/feedb unit
3-02 Minimum reference	3-02 Minimum reference	3-02 Minimum reference
3-03 Maximum reference	3-03 Maximum reference	3-03 Maximum reference
6-24 Terminal 54 low ref/feedb value	6-10 Terminal 53 low voltage	3-15 Reference 1 source
6-25 Terminal 54 high ref/feedb value	6-11 Terminal 53 high voltage	3-16 Reference 2 source
6-26 Terminal 54 Filter time constant	6-14 Terminal 53 low ref/feedb. value	20-00 Feedback 1 source
6-27 Terminal 54 live zero	6-15 Terminal 53 high ref/feedb. value	20-01 Feedback 1 conversion
6-00 Live zero timeout time	6-24 Terminal 54 low ref/feedb value	20-03 Feedback 1 source
6-01 Live zero timeout function	6-25 Terminal 54 high ref/feedb value	20-04 Feedback 2 conversion
20-81 PID normal/inverse control	6-26 Terminal 54 Filter time constant	20-06 Feedback 3 source
20-82 PID start speed [RPM]	6-27 Terminal 54 live zero	20-07 Feed back 3 conversion
20-21 Setpoint 1	6-00 Live zero timeout time	6-10 Terminal 53 low voltage
20-93 PID proportional gain	6-01 Live zero timeout function	6-11 Terminal 53 high voltage
20-94 PID integral time	20-81 PID normal/inverse control	6-14 Terminal 53 low ref/feedb. value
	20-82 PID start speed [RPM]	20-93 PID proportional gain
		20-94 PID integral time
		4-56 Warning feedback low
		4-57 Warning feedback high
		20-20 Feedback function
		20-21 Setpoint 1
		20-22 Setpoint 2

Q3-4 Application Settings		
Q3-40 Fan Functions	Q3-41 Pump Functions	Q3-42 Compressor Functions
22-60 Broken belt function	22-20 Low power auto setup	1-03 Torque characteristics
22-61 broken belt torque	22-21 Low power detection	1-71 Start delay
22-62 Broken belt delay	22-22 Low speed detection	22-75 Short cycle protection
4-64 Semi auto bypass setup	22-23 No-flow function	22-76 Interval between starts
1-03 Torque characteristics	22-24 No-flow delay	22-77 Minimum run time
22-22 Low speed detection	22-40 Minimum run time	5-01 Terminal 27 mode
22-23 No-flow function	22-41 Minimum sleep time	5-02 Terminal 29 mode
22-24 No-flow delay	22-42 Wake-up speed	5-12 Terminal 27 digital input
22-40 Minimum run time	22-26 Dry pump function	5-13 Terminal 29 digital input
22-41 Minimum sleep time	22-27 Dry pump delay	5-40 Function relay
22-42 Wake-up speed	1-03 Torque characteristics	1-73 Flying start
2-10 Brake function	1-73 Flying start	
2-17 Over-voltage control		
1-73 Flying start		
1-71 Start delay		
1-80 Function at stop		
2-00 DC hold/preheat		
4-10 Current motor speed direction		

See also *VLT® HVAC Drive Operating Instructions* for a detailed description of the Function Setups parameter groups.

<b>0-20</b>	<b>Display Line 1.1 Small</b>
<b>Value:</b>	
None	[0]
Display Text 1	[37]

Display Text 2	[38]
Display Text 3	[39]
Date and Time Readout	[89]
Profibus Warning Word	[953]

Readout Transmit Error Counter	[1005]	Pulse Output #27 [Hz]	[1669]
Readout Receive Error Counter	[1006]	Pulse Output #29 [Hz]	[1670]
Readout Bus Off Counter	[1007]	Relay Output [bin]	[1671]
Warning Parameter	[1013]	Counter A	[1672]
LON Warning Word	[1115]	Counter B	[1673]
XIF Revision	[1117]	Analog input X30/11	[1675]
LON Works Revision	[1118]	Analog input X30/12	[1676]
Running Hours	[1501]	Analog output X30/8 mA	[1677]
kWh Counter	[1502]	Fieldbus CTW 1	[1680]
Control Word	[1600]	Fieldbus REF 1	[1682]
Reference [Unit]	[1601]	Comm. Option STW	[1684]
* Reference %	[1602]	FC Port CTW 1	[1685]
Status Word	[1603]	FC Port REF 1	[1686]
Main Actual Value [%]	[1605]	Alarm Word	[1690]
Custom Readout	[1609]	Alarm Word 2	[1691]
Power [kW]	[1610]	Warning Word	[1692]
Power [hp]	[1611]	Warning Word 2	[1693]
Motor Voltage	[1612]	Ext. Status Word	[1694]
Motor Frequency	[1613]	Ext. Status Word 2	[1695]
Motor Current	[1614]	Maintenance Word	[1696]
Frequency [%]	[1615]	Analog Input X42/1	[1820]
Torque [Nm]	[1616]	Analog Input X42/3	[1821]
Speed [RPM]	[1617]	Analog Input X42/5	[1822]
Motor Thermal	[1618]	Analog Out X42/7 [mA]	[1823]
Torque [%]	[1622]	Analog Out X42/9 [mA]	[1824]
DC Link Voltage	[1630]	Analog Out X42/11 [mA]	[1825]
BrakeEnergy/s	[1632]	Ext. 1 Reference [Unit]	[2117]
BrakeEnergy/2 min	[1633]	Ext. 1 Feedback [Unit]	[2118]
Heatsink Temp.	[1634]	Ext. 1 Output [%]	[2119]
Thermal Drive Load	[1635]	Ext. 2 Reference [Unit]	[2137]
Inv. Nom. Current	[1636]	Ext. 2 Feedback [Unit]	[2138]
Inv. Max. Current	[1637]	Ext. 2 Output [%]	[2139]
SL Control State	[1638]	Ext. 3 Reference [Unit]	[2157]
Control Card Temp.	[1639]	Ext. 3 Feedback [Unit]	[2158]
External Reference	[1650]	Ext. Output [%]	[2159]
Feedback [Unit]	[1652]	No-Flow Power	[2230]
Digi Pot Reference	[1653]	User Text 1	[2320]
Feedback 1 [Unit]	[1654]	User Text 2	[2321]
Feedback 2 [Unit]	[1655]	User Text 3	[2322]
Feedback 3 [Unit]	[1656]	User Text 4	[2323]
Digital Input	[1660]	User Text 5	[2324]
Terminal 53 Switch Setting	[1661]	User Text 6	[2325]
Analog Input 53	[1662]	Cascade Status	[2580]
Terminal 54 Switch Setting	[1663]	Pump Status	[2581]
Analog Input 54	[1664]	Idle Time	[9913]
Analog Output 42 [mA]	[1665]	Paramdb Requests in Queue	[9914]
Digital Output [bin]	[1666]	Imbalance Derate [%]	[9994]
Freq. Input #29 [Hz]	[1667]	Temperature Derate [%]	[9995]
Freq. Input #33 [Hz]	[1668]		

Overload Derate [%] [9996]

#### Function:

Select a variable for display in line 1, left position.

**None** [0] No display value selected

**Control Word** [1600] Present control word

**Reference [Unit]** [1601] Total reference (sum of digital/analog/preset/bus/freeze ref./catch up and slow-down) in selected unit.

**\*Reference %** [1602] Total reference (sum of digital/analog/preset/bus/freeze ref./catch up and slow-down) in percent.

**Status Word [binary]** [1603] Present status word

**Main Actual Value** [1605] [Hex] One or more warnings in a Hex code

**Power [kW]** [1610] Actual power consumed by the motor in kW.

**Power [hp]** [1611] Actual power consumed by the motor in HP.

**Motor Voltage [V]** [1612] Voltage supplied to the motor.

**Frequency [Hz]** [1613] Motor frequency, i.e. the output frequency from the frequency converter in Hz.

**Motor Current [A]** [1614] Phase current of the motor measured as effective value.

**Frequency [%]** [1615] Motor frequency, i.e. the output frequency from the frequency converter in percent.

**Torque [%]** [1616] Present motor load as a percentage of the rated motor torque.

**Speed [RPM]** [1617] Speed in RPM (revolutions per minute) i.e. the motor shaft speed in closed loop based on the entered motor nameplate data, the output frequency and the load on the frequency converter. .

**Motor Thermal** [1618] Thermal load on the motor, calculated by the ETR function. See also parameter group 1-9\* Motor Temperature.

**DC Link Voltage [V]** [1630] Intermediate circuit voltage in the frequency converter.

**Brake Energy /s** [1632] Present brake power transferred to an external brake resistor. Stated as an instantaneous value.

**Brake Energy /2 min** [1633] Brake power transferred to an external brake resistor. The mean power is calculated continuously for the most recent 120 seconds.

**Heatsink Temperature [°C]** [1634] Present heat sink temperature of the frequency converter. The cut-out limit is 95 ±5 °C; cutting back in occurs at 70 ±5° C.

**Inverter Thermal** [1635] Percentage load of the inverters

**Inv. Nom. Current** [1636] Nominal current of the frequency converter

**Inv. Max. Current** [1637] Maximum current of the frequency converter

**SL Control State** [1638] State of the event executed by the control

**Control Card Temperature** [1639] Temperature of the control card.

**External Reference** [1650] [%] Sum of the external reference as a percentage, i.e. the sum of analog/pulse/bus.

**Feedback [Unit]** [1652] Reference value from programmed digital input(s).

**Digital Input** [1660] Displays the status of the 6 digital input terminals (18, 19, 27, 29, 32 and 33). Input 18 corresponds to the bit at the far left. Signal low = 0; Signal high = 1

**Terminal 53 Switch Setting** [1661] Setting of input terminal 53. Current = 0; Voltage = 1.

**Analog Input 53** [1662] Actual value at input 53 either as a reference or protection value.

**Terminal 54 Switch Setting** [1663] Setting of input terminal 54. Current = 0; Voltage = 1.

**Analog Input 54** [1664] Actual value at input 54 either as reference or protection value.

**Analog Output 42 [mA]** [1665] Actual value at output 42 in mA. Use par. 6-50 to select the variable to be represented by output 42.

**Digital Output [bin]** [1666] Binary value of all digital outputs.

**Frequency Input #29 [Hz]** [1667] Actual value of the frequency applied at terminal 29 as a pulse input.

**Frequency Input #33 [Hz]** [1668] Actual value of the frequency applied at terminal 33 as a pulse input.

**Pulse Output #27 [Hz]** [1669] Actual value of pulses applied to terminal 27 in digital output mode.

**Pulse Output #29 [Hz]** [1670] Actual value of pulses applied to terminal 29 in digital output mode.

**Analog In X30/11 [V]** [1675] Actual value of the signal on input X30/11 (General Purpose I/O Card. Option)

**Analog In X30/12** [1676] Actual value of the signal on input X30/11 (General Purpose I/O Card. Optional) represented by output X30/8.

**Analog Out X30/8** [1677] Actual value at output X30/8 (General Purpose I/O Card. Op-

tional) Use Par. 6-60 to select the variable to be shown.

**Fieldbus Control Word1 Signal** [1680] Control word (CTW) received from the Bus Master.

**Fieldbus Reference** [1682] Main reference value sent with control word via the serial communications network e.g. from the BMS, PLC or other master controller.

**Communication Option Status Word [binary]** [1684] Extended fieldbus communication option status word.

**FC Port Control Word1 Signal** [1685] Control word (CTW) received from the Bus Master.

**FC Port Speed Set-point A Signal** [1686] Status word (STW) sent to the Bus Master.

**Alarm word [Hex]** [1690] One or more alarms in a Hex code (used for serial communications)

**Alarm Word 2 [Hex]** [1691] One or more alarms in a Hex code (used for serial communications)

**Warning Word [Hex]** [1692] One or more warnings in a Hex code (used for serial communications)

**Warning Word 2 [Hex]** [1693] One or more warnings in a Hex code (used for serial communications)

**Ext. Status Word [Hex]** [1694] One or more status conditions in a Hex code (used for serial communications)

**Ext. Status Word 2 [Hex]** [1695] One or more status conditions in a Hex code (used for serial communications)

**Preventive Maintenance Word** [1696] The bits reflect the status for the programmed Preventive Maintenance Events in parameter group 23-1\*

**Ext. 1 Reference [Units]** [2117] The value of the reference for extended Closed Loop Controller 1

**Ext. 1 Feedback [Units]** [2118] The value of the feedback signal for extended Closed Loop Controller 1

**Ext. 1 Output [Units]** [2119] The value of the output from extended Closed Loop Controller 1

**Ext. 2 Reference[Units]** [2137] The value of the reference for extended Closed Loop Controller 2

**Ext. 2 Feedback[Units]** [2138] The value of the feedback signal for extended Closed Loop Controller 2

**Ext. 2 Output[Units]** [2139] The value of the output from extended Closed Loop Controller 2

**Ext. 3 Reference [Units]** [2157] The value of the reference for extended Closed Loop Controller 3

**Ext. 3 Feedback[Units]** [2158] The value of the feedback signal for extended Closed Loop Controller 3

**Ext. 3 Output[Units]** [2159] The value of the output from extended Closed Loop Controller 3

**No Flow Power [kW]** [2230] The calculated No Flow Power for the actual operating speed

**Cascade Status [Units]** [2580] Status for the operation of the Cascade Controller

**Pump Status [Units]** [2581] Status for the operation of each individual pump controlled by the Cascade Controller

---

#### 0-21 Display Line 1.2 Small

##### Value:

\* Motor Current [A] [1614]

##### Function:

Select a variable for display in line 1, middle position. The options are the same as those listed for par. 0-20 *Display Line 1.1 Small*.

---

#### 0-22 Display Line 1.3 Small

##### Value:

\* Power [kW] [1610]

##### Function:

Select a variable for display in line 1, right position. The options are the same as those listed for par. 0-20 *Display Line 1.1 Small*.

---

#### 0-23 Display Line 2 Large

##### Value:

\* Frequency [Hz] [1613]



**Function:**

Select a variable for display in line 2. The options are the same as those listed for par. 0-20 *Display Line 1.1 Small*.

**0-24 Display Line 3 Large****Value:**

\* Counter [kWh] [1502]

**Function:**

Select a variable for display in line 2. The options are the same as those listed for par. 0-20 *Display Line 1.1 Small*.

**0-37 Display Text 1****Function:**

In this parameter it is possible to write an individual text string for display in the LCP or to be read via serial communication. If to be displayed permanently select Display Text 1 in par. 0-20, 0-21, 0-22, 0-23 or 0-24, *Display Line XXX*. Use the  $\blacktriangle$  or  $\blacktriangledown$  buttons on the LCP to change a character. Use the  $\blacktriangleleft$  and  $\blacktriangleright$  buttons to move the cursor. Then a character is highlighted by a cursor, this character can be changed. A character can be inserted by placing the cursor between two characters and pressing  $\blacktriangle$  for  $\blacktriangledown$ .

**0-38 Display Text 2****Function:**

In this parameter it is possible to write an individual text string for display in the LCP or to be read via serial communication. If to be displayed permanently select Display Text 2 in par. 0-20, 0-21, 0-22, 0-23 or 0-24, *Display Line XXX*. Use the  $\blacktriangle$  or  $\blacktriangledown$  buttons on the LCP to change a character. Use the  $\blacktriangleleft$  and  $\blacktriangleright$  buttons to move the cursor. Then a character is highlighted by a cursor, this character can be changed. A character can be inserted by placing the cursor between two characters and pressing  $\blacktriangle$  for  $\blacktriangledown$ .

**0-39 Display Text 3****Function:**

In this parameter it is possible to write an individual text string for display in the LCP or to be read via serial communication. If to be displayed permanently select Display Text 3 in par. 0-20, 0-21, 0-22, 0-23 or 0-24, *Display Line XXX*. Use the  $\blacktriangle$  or  $\blacktriangledown$  buttons on the LCP to change a character. Use the  $\blacktriangleleft$  and  $\blacktriangleright$  buttons to move the cursor. Then a character is highlighted by a cursor, this character can be changed. A character can be inserted by placing the cursor between two characters and pressing  $\blacktriangle$  for  $\blacktriangledown$ .

**0-70 Set Date and Time****Value:**

2000-01-01 00:00 – \* 2000-01-01  
2099-12-01 23:59 00:00

**Function:**

Sets the date and time of the internal clock. The format to be used is set in par. 0-71 and 0-72.

**NB!**

This parameter does not display the actual time. This can be read in par. 0-89. The clock will not begin counting until a setting different from default has been made.

**0-71 Date Format****Value:**

YYYY-MM-DD [0]  
\* DD-MM-YYYY [1]  
MM/DD/YYYY [2]

**Function:**

Sets the date format to be used in the LCP.

**0-72 Time Format****Value:**

\* 24 H [\*0]  
12 H [1]

**Function:**  
Sets the time format to be used in the LCP.

0-74 DST/Summertime	
<b>Value:</b>	
* OFF	[0]
Manual	[2]

**Function:**  
Choose how Daylight Saving Time/Summertime should be handled. For manual DST/Summertime enter the start date and end date in par. 0-76 and 0-77.

0-76 DST/Summertime Start	
<b>Value:</b>	
2000-01-01 00:00 –	* 2000-01-01 00:00
2099-12-31 23:59	

**Function:**  
Sets the date and time when summertime/DST starts. The date is programmed in the format selected in par. 0-71.

0-77 DST/Summertime End	
<b>Value:</b>	
2000-01-01 00:00 –	* 2000-01-01 00:00
2099-12-31 23:59	

**Function:**  
Sets the date and time when summertime/DST ends. The date is programmed in the format selected in par. 0-71.

1-00 Configuration Mode	
<b>Value:</b>	
* Open loop	[0]
Closed loop	[3]

**Function:**  
*Open Loop* [0]: Motor speed is determined by applying a speed reference or by setting desired speed when in Hand Mode. Open Loop is also used if the frequency converter is part of a closed loop control system

based on an external PID controller providing a speed reference signal as output.

*Closed Loop* [3]: Motor Speed will be determined by a reference from the built-in PID controller varying the motor speed as part of a closed loop control process (e.g. constant pressure or temperature). The PID controller must be configured in par. 20-\*\*, Drive Closed Loop or via the Function Setups accessed by pressing the [Quick Menus] button. This parameter can not be changed when motor is running.

1-03 Torque Characteristics	
<b>Value:</b>	
Compressor	[0]
Variable torque	[1]
Auto energy optim. compressor	[2]
* Auto energy optim. VT	[3]

**Function:**  
*Compressor* [0]: For speed control of screw and scroll compressors. Provides a voltage which is optimized for a constant torque load characteristic of the motor in the entire range down to 15 Hz.

*Variable Torque* [1]: For speed control of centrifugal pumps and fans. Also to be used when controlling more than one motor from the same frequency converter (e.g. multiple condenser fans or cooling tower fans). Provides a voltage which is optimized for a squared torque load characteristic of the motor.

*Auto Energy Optimization Compressor* [2]: For optimum energy efficient speed control of screw and scroll compressors. Provides a voltage which is optimized for a constant torque load characteristic of the motor in the entire range down to 15Hz but in addition the AEO feature will adapt the voltage exactly to the current load situation, thereby reducing energy consumption and audible noise from the motor. To obtain optimal performance, the motor power factor cos phi must be set correctly. This value is set in par. 14-43, Motor cos phi. The parameter has a default value which is automatically adjusted when the motor data is programmed. These settings will typically ensure optimum motor voltage but if the motor power factor cos phi requires tuning, an AMA function can be carried out using

par. 1-29, Automatic Motor Adaptation (AMA). It is very rarely necessary to adjust the motor power factor parameter manually.

*Auto Energy Optimization VT* [3]: For optimum energy efficient speed control of centrifugal pumps and fans. Provides a voltage which is optimized for a squared torque load characteristic of the motor but in addition the AEO feature will adapt the voltage exactly to the current load situation, thereby reducing energy consumption and audible noise from the motor. To obtain optimal performance, the motor power factor  $\cos \phi$  must be set correctly. This value is set in par. 14-43, Motor  $\cos \phi$ . The parameter has a default value and is automatically adjusted when the motor data is programmed. These settings will typically ensure optimum motor voltage but if the motor power factor  $\cos \phi$  requires tuning, an AMA function can be carried out using par. 1-29, Automatic Motor Adaptation (AMA). It is very rarely necessary to adjust the motor power factor parameter manually.

1-29 Automatic Motor Adaptation (AMA)	
<b>Value:</b>	
* OFF	[0]
Enable complete AMA	[1]
Enable reduced AMA	[2]

**Function:**  
 The AMA function optimises dynamic motor performance by automatically optimising the advanced motor parameters (par. 1-30 to par. 1-35) while the motor is stationary. Select the type of AMA. *Enable complete AMA* [1] performs AMA of the stator resistance  $R_s$ , the rotor resistance  $R_r$ , the stator leakage reactance  $x_1$ , the rotor leakage reactance  $X_2$  and the main reactance  $X_h$ . Select *Reduced AMA* [2] performs a reduced AMA of the stator resistance  $R_s$  in the system only. Select this option if an LC filter is used between the frequency converter and the motor.

Activate the AMA function by pressing [Hand on] after selecting [1] or [2]. See also the section *Automatic Motor Adaptation*. After a normal sequence, the display will read: "Press [OK] to finish AMA". After pressing the [OK]

key the frequency converter is ready for operation.

Note:

- For the best adaptation of the frequency converter, run AMA on a cold motor.
- AMA cannot be performed while the motor is spinning.



**NB!**

It is important to set motor par. 1-2\* Motor Data correctly, since these form part of the AMA algorithm. An AMA must be performed to achieve optimum dynamic motor performance. It may take up to 10 min, depending on the power rating of the motor.



**NB!**

Avoid generating external torque during AMA.



**NB!**

If one of the settings in par. 1-2\* Motor Data is changed, par. 1-30 to 1-39, the advanced motor parameters, will return to default setting. This parameter cannot be adjusted while the motor is running.

See section *Automatic Motor Adaptation* - application example.

1-71 Start Delay	
<b>Value:</b>	
0.0 - 120.0 s	* 0.0s
<b>Function:</b>	
The function selected in par. 1-80 <i>Function at Stop</i> is active in the delay period. Enter the time delay required before commencing acceleration.	

1-73 Flying Start	
<b>Value:</b>	
* Disabled	[0]
Enabled	[1]

**Function:**

This function makes it possible to catch a motor which is spinning freely due to a mains drop-out.

**Description of choice:**

Select *Disable* [0] if this function is not required.

Select *Enable* [1] to enable the frequency converter to "catch" and control a spinning motor. When par. 1-73 is enabled, par. 1-71 *Start Delay* has no function.

Search direction for flying start is linked to the setting in par. 4-10, Motor Speed Direction.

*Clockwise* [0]: Flying start search in clockwise direction. If not successful, a DC brake is carried out.

*Both Directions* [2]: The flying start will first make a search in the direction determined by the last reference (direction). If not finding the speed it will make a search in the other direction. If not successful, a DC brake will be activated in the time set in par. 2-02, Braking Time. Start will then take place from 0 Hz.

**1-80 Function at Stop**

**Value:**

- \* Coast [0]
- DC hold/Preheat [1]

**Function:**

Select the frequency converter function after a stop command or after the speed is ramped down to the settings in par. 1-81 *Min Speed for Function at Stop [RPM]*.

Select *Coast* [0] to leave the motor in free mode.

Select *DC hold/Preheat* [1] to energize the motor with a DC holding current (see par. 2-00).

**1-90 Motor Thermal Protection**

**Value:**

- No protection [0]
- Thermistor warning [1]
- Thermistor trip [2]
- ETR warning 1 [3]
- \* ETR trip 1 [4]
- ETR warning 2 [5]

- ETR trip 2 [6]
- ETR warning 3 [7]
- ETR trip 3 [8]
- ETR warning 4 [9]
- ETR trip 4 [10]

**Function:**

The frequency converter determines the motor temperature for motor protection in two different ways:

- Via a thermistor sensor connected to one of the analog or digital inputs (par. 1-93 *Thermistor Source*).
- Via calculation (ETR = Electronic Thermal Relay) of the thermal load, based on the actual load and time. The calculated thermal load is compared with the rated motor current  $I_{M,N}$  and the rated motor frequency  $f_{M,N}$ . The calculations estimate the need for a lower load at lower speed due to less cooling from the fan incorporated in the motor.

Select *No protection* [0] if the motor is continuously overloaded and no warning or trip of frequency converter is wanted.

Select *Thermistor warning* [1] to activate a warning when the connected thermistor in the motor reacts in the event of motor over-temperature.

Select *Thermistor trip* [2] to stop (trip) the frequency converter when the connected thermistor in the motor reacts in the event of motor over-temperature.

The thermistor cut-out value is > 3 kΩ.

Integrate a thermistor (PTC sensor) in the motor for winding protection.

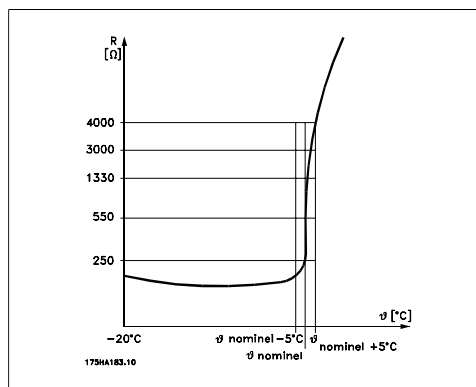

Motor protection can be implemented using a range of techniques: PTC sensor in motor

windings; mechanical thermal switch (Klixon type); or Electronic Thermal Relay (ETR).

Using a digital input and 24 V as power supply:  
Example: The frequency converter trips when the motor temperature is too high.

Parameter set-up:  
Set Par. 1-90 *Motor Thermal Protection to Thermistor Trip* [2]

Set Par. 1-93 *Thermistor Source to Digital Input* [6]

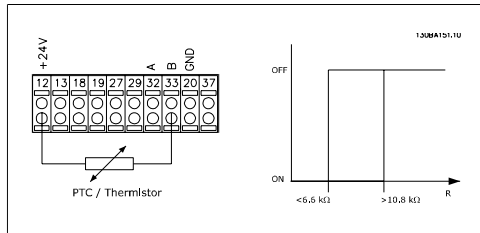

Using a digital input and 10 V as power supply:  
Example: The frequency converter trips when the motor temperature is too high.

Parameter set-up:  
Set Par. 1-90 *Motor Thermal Protection to Thermistor Trip* [2]

Set Par. 1-93 *Thermistor Source to Digital Input 33* [6]

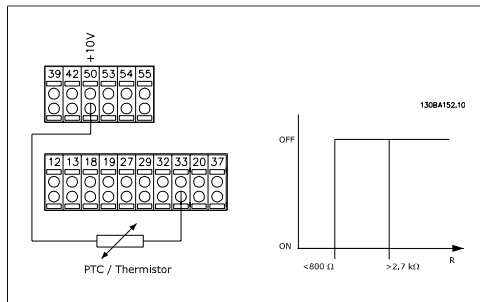

Using an analog input and 10 V as power supply:

Example: The frequency converter trips when the motor temperature is too high.

Parameter set-up:  
Set Par. 1-90 *Motor Thermal Protection to Thermistor Trip* [2]

Set Par. 1-93 *Thermistor Source to Analog Input 54* [2]

Do not select a reference source.

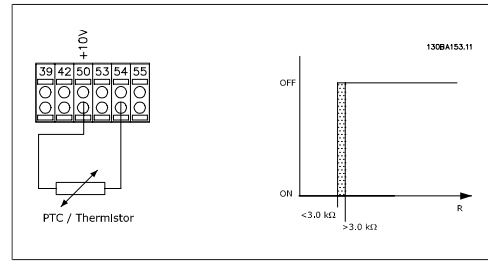

Input	Supply Voltage	Threshold Cut-out Values
Digital/analog		
Digital	24 V	< 6.6 kΩ - > 10.8 kΩ
Digital	10 V	< 800 Ω - > 2.7 kΩ
Analog	10 V	< 3.0 kΩ - > 3.0 kΩ



**NB!**

Check that the chosen supply voltage follows the specification of the used thermistor element.

Select *ETR Warning 1-4*, to activate a warning on the display when the motor is overloaded. Select *ETR Trip 1-4* to trip the frequency converter when the motor is overloaded.

Programme a warning signal via one of the digital outputs. The signal appears in the event of a warning and if the frequency converter trips (thermal warning).

ETR (Electronic Thermal Relay) functions 1-4 will calculate the load when the set-up where they were selected is active. For example ETR starts calculating when setup 3 is selected. For the North American market: The ETR functions provide class 20 motor overload protection in accordance with NEC.

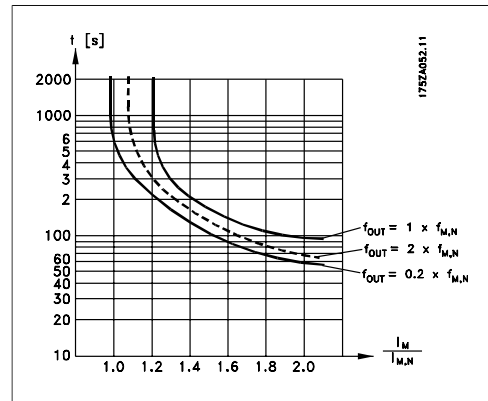

**1-93 Thermistor Source**

**Value:**

- \* None [0]
- Analog input 53 [1]
- Analog input 54 [2]

Digital input 18	[3]
Digital input 19	[4]
Digital input 32	[5]
Digital input 33	[6]

**Function:**

Select the input to which the thermistor (PTC sensor) should be connected. An analog input option [1] or [2] cannot be selected if the analog input is already in use as a reference source (selected in par. 3-15 *Reference Source 1*, 3-16 *Reference Source 2* or 3-17 *Reference Source 3*).

This parameter cannot be adjusted while the motor is running.

**2-00 DC Hold Current/Preheat Current**

**Value:**

0 - 100% \* 50 %

**Function:**

Enter a value for holding current as a percentage of the rated motor current  $I_{M,N}$  set in par. 1-24 *Motor Current*. 100% DC holding current corresponds to  $I_{M,N}$ .

This parameter holds the motor function (holding torque) or pre-heats the motor.

This parameter is active if *DC hold* is selected in par. 1-80 *Function at Stop*.



**NB!**

The maximum value depends on the rated motor current.

**NB!**

Avoid 100 % current for too long. It may damage the motor.

**2-10 Brake Function**

**Value:**

* Off	[0]
Resistor brake	[1]

**Function:**

Select *Off* [0] if no brake resistor is installed. Select *Resistor brake* [1] if a brake resistor is incorporated in the system, for dissipation of surplus brake energy as heat. Connecting a brake resistor allows a higher DC link voltage

during braking (generating operation). The Resistor brake function is only active in frequency converters with an integral dynamic brake.

**2-17 Over-voltage Control**

**Value:**

Disabled	[0]
* Enabled	[2]

**Function:**

Over-voltage control (OVC) reduces the risk of the frequency converter tripping due to an over voltage on the DC link caused by generative power from the load.

Select *Disabled* [0] if no OVC is required.

Select *Enabled* [2] to activate OVC.



**NB!**

The ramp time is automatically adjusted to avoid tripping of the frequency converter.

**3-02 Minimum Reference**

**Value:**  
-100000.000 – par. 3-03 \* 0.000 Unit

**Function:**  
Enter the Minimum Reference. The Minimum Reference is the lowest value obtainable by summing all references.

**3-03 Maximum Reference**

**Value:**  
Par. 3-02 - 100000.000 \* 0.000 Unit

**Function:**  
Enter the Maximum Reference. The Maximum Reference is the highest value obtainable by summing all references.

**3-10 Preset Reference**

Array [8]

**Value:**  
-100.00 - 100.00 % \* 0.00%

**Function:**  
Enter up to eight different preset references (0-7) in this parameter, using array programming. The preset reference is stated as a percentage of the value Ref<sub>MAX</sub> (par. 3-03 *Maximum Reference*) or as a percentage of the other external references. If a Ref<sub>MIN</sub> different from 0 (Par. 3-02 *Minimum Reference*) is programmed, the preset reference is calculated as a percentage of the full reference range, i.e. on the basis of the difference between Ref<sub>MAX</sub> and Ref<sub>MIN</sub>. Afterwards, the value is added to Ref<sub>MIN</sub>. When using preset references, select Preset ref. bit 0 / 1 / 2 [16], [17] or [18] for the corresponding digital inputs in parameter group 5.1\* Digital Inputs.

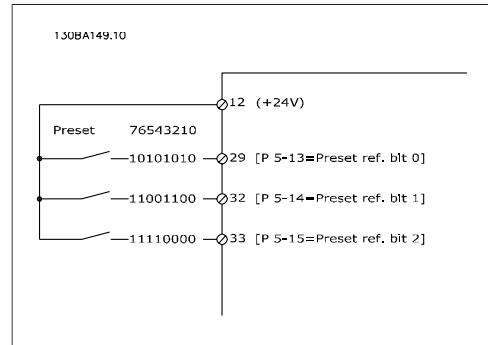

**3-15 Reference 1 Source**

**Value:**

No function	[0]
* Analog input 53	[1]
Analog input 54	[2]
Frequency input 29	[7]
Frequency input 33	[8]
Digital pot.meter	[20]
Analog input X30-11	[21]
Analog input X30-12	[22]
Analog Input X42/1	[23]
Analog Input X42/3	[24]
Analog Input X42/5	[25]
Ext. Closed Loop 1	[30]
Ext. Closed Loop 2	[31]
Ext. Closed Loop 3	[32]

**Function:**  
Select the reference input to be used for the first reference signal. Par. 3-15, 3-16 and 3-17 define up to three different reference signals. The sum of these reference signals defines the actual reference. This parameter cannot be adjusted while the motor is running.

**3-16 Reference 2 Source**

**Value:**

No function	[0]
Analog input 53	[1]
Analog input 54	[2]
Frequency input 29	[7]
Frequency input 33	[8]
* Digital pot.meter	[20]
Analog input X30-11	[21]
Analog input X30-12	[22]
Analog Input X42/1	[23]

Analog Input X42/3	[24]
Analog Input X42/5	[25]
Ext. Closed Loop 1	[30]
Ext. Closed Loop 2	[31]
Ext. Closed Loop 3	[32]

**Function:**

Select the reference input to be used for the second reference signal. Par. 3-15, 3-16 and 3-17 define up to three different reference signals. The sum of these reference signals defines the actual reference.

This parameter cannot be adjusted while the motor is running.

**4-10 Motor Speed Direction****Value:**

Clockwise	[0]
* Both directions	[2]

**Function:**

Selects the motor speed direction required. When par. 1-00 *Configuration Mode* is set to *Closed loop* [3], the parameter default is changed to *Clockwise* [0].

**4-57 Warning Feedback High****Value:**

Par. 4-56 - 999999.999 \* 999999.999

**Function:**

Enter the upper feedback limit. When the feedback exceeds this limit, the display reads Feedb High. The signal outputs can be programmed to produce a status signal on terminal 27 or 29 and on relay output 01 or 02.

**4-64 Semi-Auto By-pass Feature****Value:**

* Off	[0]
Enabled	[1]

**Function:**

Select *Enabled* to start the Semi-Automatic Bypass set-up and continue with the procedure described above.

**5-01 Terminal 27 Mode****Value:**

* Input	[0]
Output	[1]

**Function:**

Select *Input* [0] to define terminal 27 as a digital input.

Select *Output* [1] to define terminal 27 as a digital output.

This parameter cannot be adjusted while the motor is running.

**5-02 Terminal 29 Mode****Value:**

* Input	[0]
Output	[1]

**Function:**

Select *Input* [0] to define terminal 29 as a digital input.

Select *Output* [1] to define terminal 29 as a digital output.

This parameter cannot be adjusted while the motor is running.

**5-12 Terminal 27 Digital Input****Value:**

* Coast Inverse	[2]
-----------------	-----

**Function:**

Same options and functions as par. 5-1\* *Digital Inputs*, except for *Pulse input*.

**5-13 Terminal 29 Digital Input****Value:**

* Jog	[14]
-------	------

**Function:**

Same options and functions as par. 5-1\* *Digital Inputs*.



**5-14 Terminal 32 Digital Input****Value:**

\* No Operation [0]

**Function:**Same options and functions as par. 5-1\* *Digital Inputs*, except for *Pulse input*.**5-15 Terminal 33 Digital Input****Value:**

\* No Operation [0]

**Function:**Same options and functions as par. 5-1\* *Digital Inputs*.**5-40 Function Relay**

Array [8]	(Relay 1 [0], Relay 2 [1], Relay 7 [6], Relay 8 [7], Relay 9 [8])
-----------	---

**Value:**

No Operation	[0]
Control Ready	[1]
Drive Ready	[2]
Drive Ready/Remote	[3]
Stand-by/No Warning	[4]
* Running	[5]
Running/No Warning	[6]
Run on Ref./No Warning	[8]
Alarm	[9]
Alarm or Warning	[10]
At Torque Limit	[11]
Out of Current Range	[12]
Below Current, low	[13]
Above Current, high	[14]
Out of Speed Range	[15]
Below Speed, low	[16]
Above Speed, high	[17]
Out of Feedb. Range	[18]
Below Feedback, low	[19]
Above Feedback, high	[20]
Thermal Warning	[21]

Reverse	[25]
Bus OK	[26]
Torque Limit & Stop	[27]
Brake, No Warning	[28]
Brake Ready, No Fault	[29]
Brake Fault (IGBT)	[30]
External Interlock	[35]
Control Word Bit 11	[36]
Control Word Bit 12	[37]
Out of Ref. Range	[40]
Below Reference, low	[41]
Above Ref. high	[42]
Bus ctrl	[45]
Bus ctrl, 1 if timeout	[46]
Bus ctrl, 0 if timeout	[47]
Comparator 0	[60]
Comparator 1	[61]
Comparator 2	[62]
Comparator 3	[63]
Comparator 4	[64]
Comparator 5	[65]
Logic Rule 0	[70]
Logic Rule 1	[71]
Logic Rule 2	[72]
Logic Rule 3	[73]
Logic Rule 4	[74]
Logic Rule 5	[75]
SL Digital Output A	[80]
SL Digital Output B	[81]
SL Digital Output C	[82]
SL Digital Output D	[83]
SL Digital Output E	[84]
SL Digital Output F	[85]
No Alarm	[160]
Running Reverse	[161]
Local Ref. Active	[165]
Remote Ref. Active	[166]
Start Cmd. Active	[167]
Drive in Hand Mode	[168]
Drive in Auto Mode	[169]
Clock Fault	[180]
Prev. Maintenance	[181]
No-Flow	[190]
Dry Pump	[191]
End of Curve	[192]
Sleep Mode	[193]
Broken Belt	[194]
Bypass Valve Control	[195]

Cascade Pump1	[211]
Cascade Pump2	[212]
Cascade Pump3	[213]
Fire Mode Active	[220]
Fire Mode Coast	[221]
Fire Mode Was Active	[222]
Alarm, Trip Locked	[223]
Bypass Mode Active	[224]

**Function:**

Select options to define the function of the relays.

The selection of each mechanical relay is realised in an array parameter.

**6-00 Live Zero Timeout Time**

**Value:**

1 - 99 s \* 10s

**Function:**

Enter the Live Zero Time-out time period. Live Zero Time-out Time is active for analog inputs, i.e. terminal 53 or terminal 54, allocated to current and used as reference or feedback sources. If the reference signal value associated with the selected current input falls below 50% of the value set in par. 6-10, par. 6-12, par. 6-20 or par. 6-22 for a time period longer than the time set in par. 6-00, the function selected in par. 6-01 will be activated.

**6-01 Live Zero Timeout Function**

**Value:**

- \* Off [0]
- Freeze output [1]
- Stop [2]
- Jogging [3]
- Max. speed [4]
- Stop and trip [5]

**Function:**

Select the time-out function. The function set in par. 6-01 will be activated if the input signal on terminal 53 or 54 is below 50% of the value in par. 6-10, par. 6-12, par. 6-20 or par. 6-22 for a time period defined in par. 6-00. If several time-outs occur simultaneously, the fre-

quency converter prioritises the time-out functions as follows:

1. Par. 6-01 *Live Zero Time-out Function*
2. Par. 8-04 *Control-word Time-out Function*

The output frequency of the frequency converter can be:

- [1] frozen at the present value
- [2] overruled to stop
- [3] overruled to jog speed
- [4] overruled to max. speed
- [5] overruled to stop with subsequent trip

If you select set-up 1-4, par. 0-10, *Active Set-up*, must be set to *Multi Set-up*, [9].

This parameter cannot be adjusted while the motor is running.

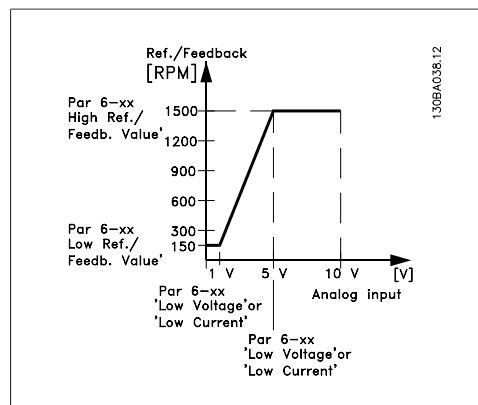

**6-10 Terminal 53 Low Voltage**

**Value:**

0.00 - par. 6-11 \* 0.07V

**Function:**

Enter the low voltage value. This analog input scaling value should correspond to the low reference/feedback value set in par. 6-14.

**6-11 Terminal 53 High Voltage**

**Value:**

Par. 6-10 to 10.0 V \* 10.0V

**Function:**

Enter the high voltage value. This analog input scaling value should correspond to the high reference/feedback value set in par. 6-15.

**6-14 Terminal 53 Low Ref./Feedb. Value****Value:**

-1000000.000 to par. 6-15 \* 0.000 Unit

**Function:**

Enter the analog input scaling value that corresponds to the low voltage/low current set in par. 6-10 and 6-12.

**6-15 Terminal 53 High Ref./Feedb. Value****Value:**

Par. 6-14 to  
1000000.000 \* 100.000 Unit

**Function:**

Enter the analog input scaling value that corresponds to the high voltage/high current value set in par. 6-11/6-13.

**6-16 Terminal 53 Filter Time Constant****Value:**

0.001 - 10.000 s \* 0.001s

**Function:**

Enter the time constant. This is a first-order digital low pass filter time constant for suppressing electrical noise in terminal 53. A high time constant value improves dampening but also increases the time delay through the filter.

This parameter cannot be adjusted while the motor is running.

**6-17 Terminal 53 Live Zero****Value:**

Disabled [0]  
\* Enabled [1]

**Function:**

This parameter makes it possible to disable the Live Zero monitoring. E.g. to be used if the analog outputs are used as part of a decentral I/O system (e.g. when not part of any frequency converter related control functions, but feeding a Building Management system with data)

**6-20 Terminal 54 Low Voltage**  
**Value:**  
 0.00 – par. 6-21 \* 0.07V  
**Function:**  
 Enter the low voltage value. This analog input scaling value should correspond to the low reference/feedback value, set in par. 6-24.

**6-21 Terminal 54 High Voltage**  
**Value:**  
 Par. 6-20 to 10.0 V \* 10.0V  
**Function:**  
 Enter the high voltage value. This analog input scaling value should correspond to the high reference/feedback value set in par. 6-25.

**6-24 Terminal 54 Low Ref./Feedb. Value**  
**Value:**  
 -1000000.000 to par. 6-25 \* 0.000 Unit  
**Function:**  
 Enter the analog input scaling value that corresponds to the low voltage/low current value set in par. 6-20/6-22.

**6-25 Terminal 54 high ref./feedb. value**  
**Value:**  
 Par. 6-24 to 1000000.000 \* 100.000 Unit  
**Function:**  
 Enter the analog input scaling value that corresponds to the high voltage/high current value set in par. 6-21/6-23.

**6-26 Terminal 54 Filter Time Constant**  
**Value:**  
 0.001 - 10.000 s \* 0.001s  
**Function:**  
 Enter the time constant. This is a first-order digital low pass filter time constant for suppressing electrical noise in terminal 54. A high time constant value improves dampening but

also increases the time delay through the filter.  
 This parameter cannot be adjusted while the motor is running.

**6-27 Terminal 54 Live Zero**  
**Value:**  
 Disabled [0]  
 \* Enabled [1]  
**Function:**  
 This parameter makes it possible to disable the Live Zero monitoring. E.g. to be used if the analog outputs are used as part of a decentral I/O system (e.g. when not part of any frequency converter related control functions, but feeding a Building Management System with data)

**6-50 Terminal 42 Output**  
**Value:**  
 No operation [0]  
 \* Output frequency [100]  
 Reference [101]  
 Feedback [102]  
 Motor current [103]  
 Torque rel to lim [104]  
 Torque rel to rated [105]  
 Power [106]  
 Speed [107]  
 Torque [108]  
 Ext. closed loop 1 [113]  
 Ext. closed loop 2 [114]  
 Ext. closed loop 3 [115]  
 Output freq. 4-20mA [130]  
 Reference 4-20mA [131]  
 Feedback 4-20mA [132]  
 Motor cur. 4-20mA [133]  
 Torque % lim. 4-20mA [134]  
 Torque % nom 4-20mA [135]  
 Power 4-20mA [136]  
 Speed 4-20mA [137]  
 Torque 4-20mA [138]  
 Bus ctrl. 0-20 mA [139]  
 Bus ctrl. 4-20 mA [140]  
 Bus ctrl. 0-20 mA, timeout [141]  
 Bus ctrl. 4-20 mA, timeout [142]

- Ext. Closed Loop 1, 4-20 mA [[143]]
- Ext. Closed Loop 2, 4-20 mA [[144]]
- Ext. Closed Loop 3, 4-20 mA [[145]]

**Function:**

Select the function of Terminal 42 as an analog current output.

**6-51 Terminal 42 Output Min Scale**

**Value:**

0.00 – 200% \* 0%

**Function:**

Scale the minimum output of the selected analog signal at terminal 42, as a percentage of the maximum signal value. E.g. if 0 mA (or 0 Hz) is desired at 25% of the maximum output value, then programme 25%. Scaling values up to 100% can never be higher than the corresponding setting in par. 6-52.

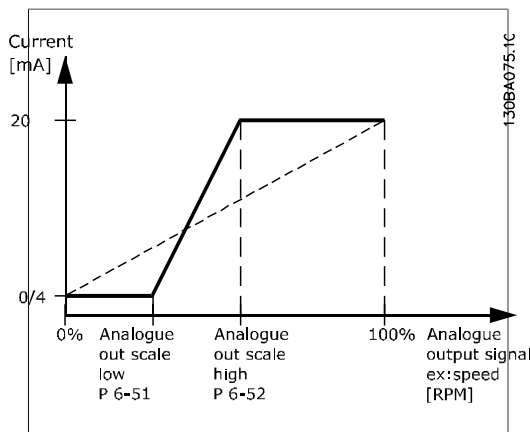

**6-52 Terminal 42 Output Max Scale**

**Value:**

0.00 – 200% \* 100%

**Function:**

Scale the maximum output of the selected analog signal at terminal 42. Set the value to the maximum value of the current signal output. Scale the output to give a current lower than 20 mA at full scale; or 20 mA at an output below 100% of the maximum signal value. If 20 mA is the desired output current at a value between 0 - 100% of the full-scale output, programme the percentage value in the parameter, i.e. 50% = 20 mA. If a current between 4 and 20 mA is desired at maximum

output (100%), calculate the percentage value as follows:

$$20 \text{ mA} / \text{desired maximum current} \times 100 \%$$

$$\text{i.e. } 10 \text{ mA}: \frac{20 \text{ mA}}{10 \text{ mA}} \times 100 \% = 200 \%$$

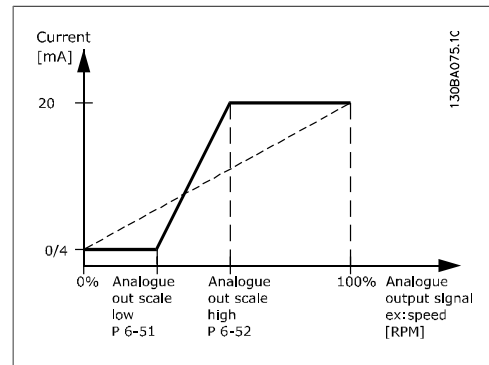

**14-01 Switching Frequency**

**Value:**

- 1.0 kHz [0]
- 1.5 kHz [1]
- 2.0 kHz [2]
- 2.5 kHz [3]
- 3.0 kHz [4]
- 3.5 kHz [5]
- 4.0 kHz [6]
- 5.0 kHz [7]
- 6.0 kHz [8]
- 7.0 kHz [9]
- 8.0 kHz [10]
- 10.0 kHz [11]
- 12.0 kHz [12]
- 14.0 kHz [13]
- 16.0 kHz [14]

**Function:**

Select the inverter switching frequency. Changing the switching frequency can help to reduce acoustic noise from the motor.



**NB!**

The output frequency value of the frequency converter must never exceed 1/10 of the switching frequency. When the motor is running, adjust the switching frequency in par. 14-01 until the motor is as noiseless as possible. See also

par. 14-00 and the section *Derating*.



**NB!**  
Switching frequencies higher than 5.0 kHz lead to automatic derating of the maximum output of the frequency converter.

**20-00 Feedback 1 Source**

**Value:**

No Function	[0]
Analog Input 53	[1]
* Analog Input 54	[2]
Frequency Input 29	[3]
Frequency Input 33	[4]
Analog Input X30/11	[7]
Analog Input X30/12	[8]
Analog Input X42/1	[9]
Analog Input X42/3	[10]
Bus Feedback 1	[100]
Bus Feedback 2	[101]
Bus Feedback 3	[102]

**Function:**

Up to three different feedback signals can be used to provide the feedback signal for the frequency converter's PID Controller. This parameter defines which input will be used as the source of the first feedback signal. Analog input X30/11 and Analog input X30/12 refer to inputs on the optional General Purpose I/O board.



**NB!**  
If a feedback is not used, its source must be set to *No Function* [0]. Parameter 20-10 determines how the three possible feedbacks will be used by the PID Controller.

**20-01 Feedback 1 Conversion**

**Value:**

* Linear	[0]
Square root	[1]
Pressure to temperature	[2]

**Function:**

This parameter allows a conversion function to be applied to Feedback 1.

*Linear* [0] has no effect on the feedback.

*Square root* [1] is commonly used when a pressure sensor is used to provide flow feedback (  $flow \propto \sqrt{pressure}$  ).

*Pressure to temperature* [2] is used in compressor applications to provide temperature feedback using a pressure sensor. The temperature of the refrigerant is calculated using the following formula:

$$Temperature = \frac{A}{2}, \text{ where } A1, A2 \text{ and } A3$$

are refrigerant-specific constants. The refrigerant must be selected in parameter 20-20. Parameters 20-21 through 20-23 allow the values of A1, A2 and A3 to be entered for a refrigerant that is not listed in parameter 20-20.

**20-03 Feedback 2 Source**

**Function:**

See *Feedback 1 Source*, par. 20-00 for details.

**20-04 Feedback 2 Conversion**

**Function:**

See *Feedback 1 Conversion* par. 20-01 for details.

**20-06 Feedback 3 Source**

**Function:**

See *Feedback 1 Source*, par. 20-00 for details.

**20-07 Feedback 3 Conversion**

**Function:**

See *Feedback 1 Conversion*, par. 20-01 for details.

20-20 Feedback Function	
<b>Value:</b>	
Sum	[0]
Difference	[1]
Average	[2]
* Minimum	[3]
Maximum	[4]
Multi setpoint min	[5]
Multi setpoint max	[6]

**Function:**  
 This parameter determines how the three possible feedbacks will be used to control the output frequency of the frequency converter.



**NB!**  
 Any unused feedback must be set to "No function" in its Feedback Source parameter: 20-00, 20-03 or 20-06.

The feedback resulting from the function selected in par. 20-20 will be used by the PID Controller to control the output frequency of the frequency converter. This feedback can also be shown on the frequency converter's display, be used to control a frequency converter's analog output, and be transmitted over various serial communication protocols.

The frequency converter can be configured to handle multi zone applications. Two different multi zone applications are supported:

- Multi zone, single setpoint
- Multi zone, multi setpoint

The difference between the two is illustrated by the following examples:

**Example 1 – Multi zone, single setpoint**

In an office building, a VAV (variable air volume) HVAC system must ensure a minimum pressure at selected VAV boxes. Due to the varying pressure losses in each duct, the pressure at each VAV box cannot be assumed to be the same. The minimum pressure required is the same for all VAV boxes. This control method can be set up by setting *Feedback Function*, par. 20-20 to option [3], Minimum, and entering the desired pressure in par. 20-21. The PID Controller will increase the speed of the fan if any one feedback is below the setpoint and decrease the speed of the fan if all feedbacks are above the setpoint.

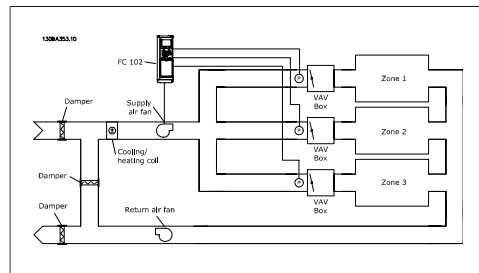

**Example 2 – Multi zone, multi setpoint**

The previous example can be used to illustrate the use of multi zone, multi setpoint control. If the zones require different pressures for each VAV box, each setpoint may be specified in par. 20-21, 20-22 and 20-23. By selecting *Multi setpoint minimum*, [5], in par. 20-20, Feedback Function, the PID Controller will increase the speed of the fan if any one of the feedbacks is below its setpoint and decrease the speed of the fan if all feedbacks are above their individual setpoints.

*Sum* [0] sets up the PID Controller to use the sum of Feedback 1, Feedback 2 and Feedback 3 as the feedback.



**NB!**  
 Any unused feedbacks must be set to *No Function* in par. 20-00, 20-03, or 20-06.

The sum of Setpoint 1 and any other references that are enabled (see par. group 3-1\*) will be used as the PID Controller's setpoint reference.

*Difference* [1] sets up the PID Controller to use the difference between Feedback 1 and Feedback 2 as the feedback. Feedback 3 will not be used with this selection. Only setpoint 1 will be used. The sum of Setpoint 1 and any other references that are enabled (see par. group 3-1\*) will be used as the PID Controller's setpoint reference.

*Average* [2] sets up the PID Controller to use the average of Feedback 1, Feedback 2 and Feedback 3 as the feedback.



**NB!**  
 Any unused feedbacks must be set to *No Function* in par. 20-00, 20-03, or 20-06. The sum of Setpoint 1 and any other references that are enabled (see par. group 3-1\*) will be used as the PID Controller's setpoint reference.

*Minimum* [3] sets up the PID Controller to compare Feedback 1, Feedback 2 and Feedback 3 and use the lowest value as the feedback.

**NB!**

Any unused feedbacks must be set to *No Function* in par. 20-00, 20-03, or 20-06. Only setpoint 1 will be used. The sum of Setpoint 1 and any other references that are enabled (see par. group 3-1\*) will be used as the PID Controller's setpoint reference.

*Maximum* [4] sets up the PID Controller to compare Feedback 1, Feedback 2 and Feedback 3 and use the highest value as the feedback.

**NB!**

Any unused feedbacks must be set to *No Function* in par. 20-00, 20-03, or 20-06.

Only Setpoint 1 will be used. The sum of Setpoint 1 and any other references that are enabled (see par. group 3-1\*) will be used as the PID Controller's setpoint reference.

*Multi-setpoint minimum* [5] sets up the PID Controller to calculate the difference between Feedback 1 and Setpoint 1, Feedback 2 and Setpoint 2, and Feedback 3 and Setpoint 3. It will use the feedback/setpoint pair in which the feedback is the farthest below its corresponding setpoint reference. If all feedback signals are above their corresponding setpoints, the PID Controller will use the feedback/setpoint pair in which the difference between the feedback and setpoint is the least.

**NB!**

If only two feedback signals are used, the feedback that is not to be used must be set to *No Function* in par. 20-00, 20-03 or 20-06. Note that each setpoint reference will be the sum of its respective parameter value (20-11, 20-12 and 20-13) and any other references that are enabled (see par. group 3-1\*).

*Multi-setpoint maximum* [6] sets up the PID Controller to calculate the difference between Feedback 1 and Setpoint 1, Feedback 2 and Setpoint 2, and Feedback 3 and Setpoint 3. It will use the feedback/setpoint pair in which

the feedback is farthest above its corresponding setpoint reference. If all feedback signals are below their corresponding setpoints, the PID Controller will use the feedback/setpoint pair in which the difference between the feedback and the setpoint reference is the least.

**NB!**

If only two feedback signals are used, the feedback that is not to be used must be set to *No Function* in par. 20-00, 20-03 or 20-06. Note that each setpoint reference will be the sum of its respective parameter value (20-21, 20-22 and 20-23) and any other references that are enabled (see par. group 3-1\*).

**20-21 Setpoint 1****Value:**

Ref<sub>MIN</sub> par.3-02 - Ref<sub>MAX</sub> par.  
3-03 UNIT (from par. 20-12) \* 0.000

**Function:**

Setpoint 1 is used in Closed Loop Mode to enter a setpoint reference that is used by the frequency converter's PID Controller. See the description of *Feedback Function*, par. 20-20.

**NB!**

Setpoint reference entered here is added to any other references that are enabled (see par. group 3-1\*).

**20-22 Setpoint 2****Value:**

Ref<sub>MIN</sub> - Ref<sub>MAX</sub> UNIT (from par.  
20-12) \* 0.000

**Function:**

Setpoint 2 is used in Closed Loop Mode to enter a setpoint reference that may be used by the frequency converter's PID Controller. See the description of *Feedback Function*, par. 20-20.

**NB!**

The setpoint reference entered here is added to any other ref-



ences that are enabled (see par. group 3-1\*).

Enabled [1]

**Function:**

Select Enabled for detecting when the motor operates with a speed as set in par. 4-11 or 4-12, *Motor Low Limit*.

**20-93 PID Proportional Gain**

**Value:**

0.00 = Off - 10.00 \* 0.50

**Function:**

This parameter adjusts the output of the frequency converter's PID Controller based on the error between the feedback and the setpoint reference. Quick PID Controller response is obtained when this value is large. However, if too large of a value is used, the frequency converter's output frequency may become unstable.

**22-23 No-Flow Function**

**Value:**

- \* Off [0]
- Sleep Mode [1]
- Warning [2]
- Alarm [3]

**Function:**

Common actions for Low Power Detection and Low Speed Detection (Individual selections not possible).

Warning: Messages in the Local Control Panel display (if mounted) and/or signal via a relay or a digital output.

Alarm: The frequency converter trips and motor stays stopped until reset.

**20-94 PID Integral Time**

**Value:**

0.01 - 10000.00 = Off s \* 20.00 s

**Function:**

The integrator adds over time (integrates) the error between the feedback and the setpoint reference. This is required to ensure that the error approaches zero. Quick frequency converter speed adjustment is obtained when this value is small. However, if too small of a value is used, the frequency converter's output frequency may become unstable.

**22-24 No-Flow Delay**

**Value:**

0-600 sec. \* 10 sec.

**Function:**

Set the time Low Power/Low Speed must stay detected to activate signal for actions. If detection disappears before run out of the timer, the timer will be reset.

**22-21 Low PowerDetection**

**Value:**

- \* Disabled [0]
- Enabled [1]

**Function:**

If selecting Enabled, the Low Power Detection commissioning must be carried out in order to set the parameters in group 22-3\* for proper operation!

**22-26 Dry Pump Function**

**Value:**

- \* Off [0]
- Warning [1]
- Alarm [2]

**Function:**

*Low Power Detection* must be Enabled (par. 22-21) and commissioned (using either par. 22-3\*, *No Flow Power Tuning*, or *Auto Set-*

**22-22 Low Speed Detection**

**Value:**

- \* Disabled [0]

Up, Par. 22-20) in order to use Dry Pump Detection.

Warning: Messages in the Local Control Panel display (if mounted) and/or signal via a relay or a digital output.

Alarm: The frequency converter trips and motor stays stopped until reset.

---

**22-40 Minimum Run Time**

**Value:**  
0 - 600 s \* 10 s

**Function:**  
Set the desired minimum running time for the motor after a Start command (digital input or Bus) before entering Sleep Mode.

---

**22-41 Minimum Sleep Time**

**Value:**  
0 - 600 s \* 10 s

**Function:**  
Set the desired minimum time for staying in Sleep Mode. This will override any wake up conditions.

---

**22-42 Wake-Up Speed [RPM]**

**Value:**  
par. 4-11 (Motor Speed Low Limit) - Par. 4-13 (Motor Speed High Limit)

**Function:**  
To be used if par. 0-02, *Motor Speed Unit*, has been set for RPM (parameter not visible if Hz selected). Only to be used if par. 1-00, *Configuration Mode*, is set for Open Loop and speed reference is applied by an external controller.  
Set the reference speed at which the Sleep Mode should be cancelled.

---

**22-60 Broken Belt Function**

**Value:**  
\* Disabled [0]  
Warning [1]

---

Trip [2]

**Function:**  
Selects the action to be performed if the Broken Belt condition is detected

---

**22-61 Broken Belt Torque**

**Value:**  
0 - 100% \* 10%

**Function:**  
Sets the broken belt torque as a percentage of the rated motor torque.

---

**22-62 Broken Belt Delay**

**Value:**  
0 - 600 s \* 10 s

**Function:**  
Sets the time for which the Broken Belt conditions must be active before carrying out the action selected in *Broken Belt Function*, par. 22-60.

---

**22-75 Short Cycle Protection**

**Value:**  
\* Disabled [0]  
Enabled [1]

**Function:**  
*Disabled* [0]: Timer set in *Interval Between Starts*, par. 22-76 is disabled.  
*Enabled* [1]: Timer set in *Interval between Starts*, par. 22-76 is enabled.

---

**22-76 Interval Between Starts**

**Value:**  
0 - 3600 s \* 0 s

**Function:**  
Sets the time desired as minimum time between two starts. Any normal start command (Start/Jog/Freeze) will be disregarded until the timer has expired.

---

**22-77 Minimum Run Time****Value:**

0 - par. 22-76 \* 0 s

**Function:**

Sets the time desired as min. run time after a normal start command (Start/Jog/Freeze).

Any normal stop command will be disregarded until the set time has expired. The timer will start counting at a normal start command (Start/Jog/Freeze).

The timer will be overridden by a Coast (Inverse) or an External Interlock command.

### 6.1.4. Main Menu Mode

Both the GLCP and NLCP provide access to the main menu mode. Select the Main Menu mode by pressing the [Main Menu] key. Illustration 6.2 shows the resulting read-out, which appears on the display of the GLCP.

Lines 2 through 5 on the display show a list of parameter groups which can be chosen by toggling the up and down buttons.

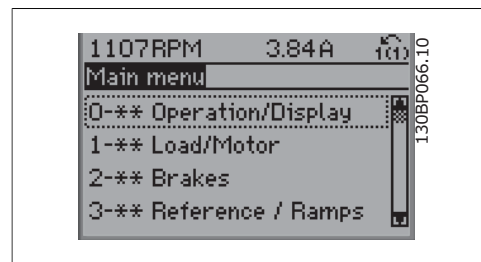

Illustration 6.9: Display example.

Each parameter has a name and number which remain the same regardless of the programming mode. In the Main Menu mode, the parameters are divided into groups. The first digit of the parameter number (from the left) indicates the parameter group number.

All parameters can be changed in the Main Menu. The configuration of the unit (par.1-00) will determine other parameters available for programming. For example, selecting Closed Loop enables additional parameters related to closed loop operation. Option cards added to the unit enable additional parameters associated with the option device.

### 6.1.5. Parameter Selection

In the Main Menu mode, the parameters are divided into groups. Select a parameter group by means of the navigation keys.

The following parameter groups are accessible:

Group no.	Parameter group:
0	Operation/Display
1	Load/Motor
2	Brakes
3	References/Ramps
4	Limits/Warnings
5	Digital In/Out
6	Analog In/Out
8	Comm. and Options
13	Smart Logic
14	Special Functions
15	Drive Information
16	Data Readouts
18	Data Readouts 2
20	Drive Closed Loop
21	Ext. Closed Loop
22	Application Functions
23	Time-based Functions
25	Cascade Controller

Table 6.3: Parameter groups.

After selecting a parameter group, choose a parameter by means of the navigation keys.

The middle section on the GLCP display shows the parameter number and name as well as the selected parameter value.

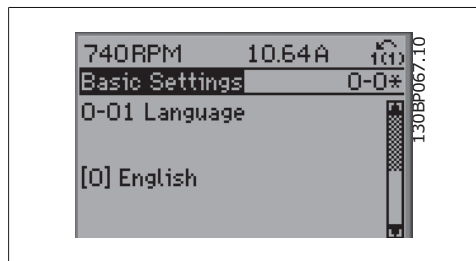

Illustration 6.10: Display example.

### 6.1.6. Changing Data

1. Press [Quick Menu] or [Main Menu] key.
2. Use [▲] and [▼] keys to find parameter group to edit.
3. Use [▲] and [▼] keys to find parameter to edit.
4. Press [OK] key.
5. Use [▲] and [▼] keys to select correct parameter setting. Or, to move to digits within a number, use keys. Cursor indicates digit selected to change. [▲] key increases the value, [▼] key decreases the value.
6. Press [Cancel] key to disregard change, or press [OK] key to accept change and enter new setting.

### 6.1.7. Changing a Text Value

If the selected parameter is a text value, change the text value by means of the up/down navigation keys.

The up key increases the value, and the down key decreases the value. Place the cursor on the value to be saved and press [OK].

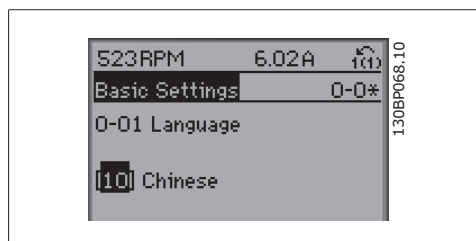

Illustration 6.11: Display example.

### 6.1.8. Changing a Group of Numeric Data Values

If the chosen parameter represents a numeric data value, change the chosen data value by means of the <> navigation keys as well as the up/down navigation keys. Use the <> navigation keys to move the cursor horizontally.

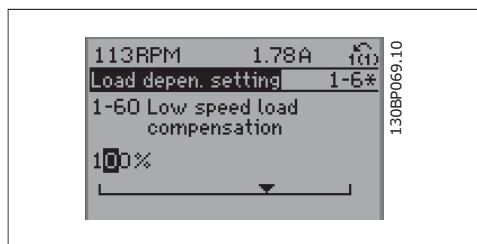

Illustration 6.12: Display example.

Use the up/down navigation keys to change the data value. The up key enlarges the data value, and the down key reduces the data value. Place the cursor on the value to be saved and press [OK].

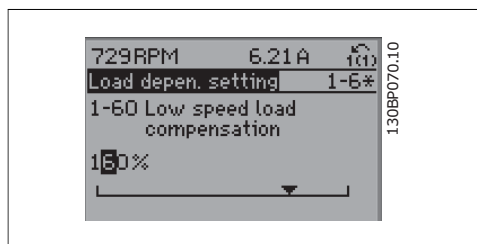

Illustration 6.13: Display example.

### 6.1.9. Changing of Data Value, Step-by-Step

Certain parameters can be changed step by step or infinitely variably. This applies to *Motor Power* (par. 1-20), *Motor Voltage* (par. 1-22) and *Motor Frequency* (par. 1-23).

The parameters are changed both as a group of numeric data values and as numeric data values infinitely variably.

### 6.1.10. Read-out and Programming of Indexed Parameters

Parameters are indexed when placed in a rolling stack.

Par. 15-30 to 15-32 contain a fault log which can be read out. Choose a parameter, press [OK], and use the up/down navigation keys to scroll through the value log.

Use par. 3-10 as another example:

Choose the parameter, press [OK], and use the up/down navigation keys to scroll through the indexed values. To change the parameter value, select the indexed value and press [OK]. Change the value by using the up/down keys. Press [OK] to accept the new setting. Press [Cancel] to abort. Press [Back] to leave the parameter.

**20-81 PID Normal/Inverse Control**

**Value:**

- \* Normal [0]
- Inverse [1]

**Function:**

*Normal* [0] causes the frequency converter's output frequency to decrease when the feed-

back is greater than the setpoint reference. This is common for pressure-controlled supply fan and pump applications.

*Inverse* [1] causes the frequency converter's output frequency to increase when the feed-back is greater than the setpoint reference. This is common for temperature-controlled cooling applications, such as cooling towers.

### 6.1.11. Initialisation to Default Settings

Initialise the frequency converter to default settings in two ways:

Recommended initialisation (via par. 14-22)

1. Select par. 14-22
2. Press [OK]
3. Select "Initialisation"
4. Press [OK]
5. Cut off the mains supply and wait until the display turns off.
6. Reconnect the mains supply - the frequency converter is now reset.
7. Change par. 14-22 back to *Normal Operation*.



**NB!** Keeps parameters selected in *Personal Menu* with default factory setting.

Par. 14-22 initialises all except:	
14-50	<i>RFI 1</i>
8-30	<i>Protocol</i>
8-31	<i>Address</i>
8-32	<i>Baud Rate</i>
8-35	<i>Minimum Response Delay</i>
8-36	<i>Max Response Delay</i>
8-37	<i>Max Inter-char Delay</i>
15-00 to 15-05	Operating data
15-20 to 15-22	Historic log
15-30 to 15-32	Fault log

**Manual initialisation**

1. Disconnect from mains and wait until the display turns off.
- 2a. Press [Status] - [Main Menu] - [OK] at the same time while power up for LCP 102, Graphical Display
- 2b. Press [Menu] while power up for LCP 101, Numerical Display
3. Release the keys after 5 s.
4. The frequency converter is now programmed according to default settings.

This procedure initialises all except:

15-00	<i>Operating Hours</i>
15-03	<i>Power-up's</i>
15-04	<i>Over temp's</i>
15-05	<i>Over volt's</i>

**NB!**

When you carry out manual initialisation, you also reset serial communication, RFI filter settings (par. 14-50) and fault log settings.  
Removes parameters selected in *Personal Menu*.

**NB!**

After initialization and power cycling, the display will not show any information until after a couple of minutes.

**4-56 Warning Feedback Low****Value:**

-999999.999 to  
+999999.999 \* -999999.999

**Function:**

Enter the lower feedback limit. When the feedback falls below this limit, the display reads Feedb Low. The signal outputs can be programmed to produce a status signal on terminal 27 or 29 and on relay output 01 or 02.

## 6.2. Parameter list

Parameters for VLT HVAC Drive FC 102 are grouped into various parameter groups for easy selection of the correct parameters for optimized operation of the frequency converter.

The vast majority of HVAC applications can be programmed using the Quick Menu button and selecting the parameters under Quick Setup and Function Setups.

Descriptions and default settings of parameters may be found under the section Parameter Lists at the back of this manual.

0-xx Operation/Display	10-xx CAN Fieldbus
1-xx Load/Motor	11-xx LonWorks
2-xx Brakes	13-xx Smart Logic
3-xx Reference/Ramps	14-xx Special Functions
4-xx Limits/ Warnings	15-xx FC Information
5-xx Digital In/Out	16-xx Data Readouts
6-xx Analog In/Out	18-xx Data Readouts 2
8-xx Comm. and Options	20-xx FC Closed Loop
9-xx Profibus	21-xx Ext. Closed Loop
	22-xx Application Functions
	23-xx Timed Actions
	25-xx Cascade Controller
	26-xx Analog I/O Option MCB 109



### 6.2.1. 0-\*\* Operation and Display

Par. No. #	Parameter description	Default value	4-set-up	Change during operation	Conversion index	Type
<b>0-0* Basic Settings</b>						
0-01	Language	[0] English	1 set-up	TRUE	-	Uint8
0-02	Motor Speed Unit	[0] RPM	2 set-ups	FALSE	-	Uint8
0-03	Regional Settings	[0] International	2 set-ups	FALSE	-	Uint8
0-04	Operating State at Power-up	[0] Resume	All set-ups	TRUE	-	Uint8
0-05	Local Mode Unit	[0] As Motor Speed Unit	2 set-ups	FALSE	-	Uint8
<b>0-1* Set-up Operations</b>						
0-10	Active Set-up	[1] Set-up 1	1 set-up	TRUE	-	Uint8
0-11	Programming Set-up	[9] Active Set-up	All set-ups	TRUE	-	Uint8
0-12	This Set-up Linked to	[0] Not linked	All set-ups	FALSE	-	Uint8
0-13	Readout: Linked Set-ups	0 N/A	All set-ups	FALSE	0	Uint16
0-14	Readout: Prog. Set-ups / Channel	0 N/A	All set-ups	TRUE	0	Int32
<b>0-2* LCP Display</b>						
0-20	Display Line 1.1 Small	1602	All set-ups	TRUE	-	Uint16
0-21	Display Line 1.2 Small	1614	All set-ups	TRUE	-	Uint16
0-22	Display Line 1.3 Small	1610	All set-ups	TRUE	-	Uint16
0-23	Display Line 2 Large	1613	All set-ups	TRUE	-	Uint16
0-24	Display Line 3 Large	1502	All set-ups	TRUE	-	Uint16
0-25	My Personal Menu	ExpressionLimit	1 set-up	TRUE	0	Uint16
<b>0-3* LCP Custom Readout</b>						
0-30	Custom Readout Unit	[1] %	All set-ups	TRUE	-	Uint8
0-31	Custom Readout Min Value	ExpressionLimit	All set-ups	TRUE	-2	Int32
0-32	Custom Readout Max Value	100.00 CustomReadoutUnit	All set-ups	TRUE	-2	Int32
0-37	Display Text 1	0 N/A	1 set-up	TRUE	0	VisStr[25]
0-38	Display Text 2	0 N/A	1 set-up	TRUE	0	VisStr[25]
0-39	Display Text 3	0 N/A	1 set-up	TRUE	0	VisStr[25]
<b>0-4* LCP Keypad</b>						
0-40	[Hand on] Key on LCP	[1] Enabled	All set-ups	TRUE	-	Uint8
0-41	[Off] Key on LCP	[1] Enabled	All set-ups	TRUE	-	Uint8
0-42	[Auto on] Key on LCP	[1] Enabled	All set-ups	TRUE	-	Uint8
0-43	[Reset] Key on LCP	[1] Enabled	All set-ups	TRUE	-	Uint8
0-44	[Off/Reset] Key on LCP	[1] Enabled	All set-ups	TRUE	-	Uint8
0-45	[Drive Bypass] Key on LCP	[1] Enabled	All set-ups	TRUE	-	Uint8
<b>0-5* Copy/Save</b>						
0-50	LCP Copy	[0] No copy	All set-ups	FALSE	-	Uint8
0-51	Set-up Copy	[0] No copy	All set-ups	FALSE	-	Uint8

Par. No. #	Parameter description	Default value	4-set-up	Change during operation	Conversion index	Type
<b>0-6* Password</b>						
0-60	Main Menu Password	100 N/A	1 set-up	TRUE	0	Uint16
0-61	Access to Main Menu w/o Password	[0] Full access	1 set-up	TRUE	-	Uint8
0-65	Personal Menu Password	200 N/A	1 set-up	TRUE	0	Uint16
0-66	Access to Personal Menu w/o Password	[0] Full access	1 set-up	TRUE	-	Uint8
<b>0-7* Clock Settings</b>						
0-70	Set Date and Time	ExpressionLimit	1 set-up	TRUE	0	TimeOfDay
0-71	Date Format	null	1 set-up	TRUE	-	Uint8
0-72	Time Format	null	1 set-up	TRUE	-	Uint8
0-74	DST/Summertime	[0] Off	1 set-up	TRUE	-	Uint8
0-76	DST/Summertime Start	ExpressionLimit	1 set-up	TRUE	0	TimeOfDay
0-77	DST/Summertime End	ExpressionLimit	1 set-up	TRUE	0	TimeOfDay
0-79	Clock Fault	[0] Disabled	1 set-up	TRUE	-	Uint8
0-81	Working Days	null	1 set-up	TRUE	-	Uint8
0-82	Additional Working Days	ExpressionLimit	1 set-up	TRUE	0	TimeOfDay
0-83	Additional Non-Working Days	ExpressionLimit	1 set-up	TRUE	0	TimeOfDay
0-89	Date and Time Readout	0 N/A	All set-ups	TRUE	0	VisStr[25]

### 6.2.2. 1-\*\* Load/Motor

Par. No. #	Parameter description	Default value	4-set-up	Change during operation	Conversion index	Type
<b>1-0* General Settings</b>						
1-00	Configuration Mode	null	All set-ups	TRUE	-	Uint8
1-03	Torque Characteristics	[3] Auto Energy Optim. VT	All set-ups	TRUE	-	Uint8
<b>1-2* Motor Data</b>						
1-20	Motor Power [kW]	ExpressionLimit	All set-ups	FALSE	1	Uint32
1-21	Motor Power [HP]	ExpressionLimit	All set-ups	FALSE	-2	Uint32
1-22	Motor Voltage	ExpressionLimit	All set-ups	FALSE	0	Uint16
1-23	Motor Frequency	ExpressionLimit	All set-ups	FALSE	0	Uint16
1-24	Motor Current	ExpressionLimit	All set-ups	FALSE	-2	Uint32
1-25	Motor Nominal Speed	ExpressionLimit	All set-ups	FALSE	67	Uint16
1-28	Motor Rotation Check	[0] Off	All set-ups	FALSE	-	Uint8
1-29	Automatic Motor Adaptation (AMA)	[0] Off	All set-ups	FALSE	-	Uint8
<b>1-3* Adv. Motor Data</b>						
1-30	Stator Resistance (Rs)	ExpressionLimit	All set-ups	FALSE	-4	Uint32
1-31	Rotor Resistance (Rr)	ExpressionLimit	All set-ups	FALSE	-4	Uint32
1-35	Main Reactance (Xh)	ExpressionLimit	All set-ups	FALSE	-4	Uint32
1-36	Iron Loss Resistance (Rfe)	ExpressionLimit	All set-ups	FALSE	-3	Uint32
1-39	Motor Poles	ExpressionLimit	All set-ups	FALSE	0	Uint8
<b>1-5* Load Indep. Setting</b>						
1-50	Motor Magnetisation at Zero Speed	100 %	All set-ups	TRUE	0	Uint16
1-51	Min Speed Normal Magnetising [RPM]	ExpressionLimit	All set-ups	TRUE	67	Uint16
1-52	Min Speed Normal Magnetising [Hz]	ExpressionLimit	All set-ups	TRUE	-1	Uint16
<b>1-6* Load Depen. Setting</b>						
1-60	Low Speed Load Compensation	100 %	All set-ups	TRUE	0	Int16
1-61	High Speed Load Compensation	100 %	All set-ups	TRUE	0	Int16
1-62	Slip Compensation	0 %	All set-ups	TRUE	0	Int16
1-63	Slip Compensation Time Constant	0.10 s	All set-ups	TRUE	-2	Uint16
1-64	Resonance Dampening	100 %	All set-ups	TRUE	0	Uint16
1-65	Resonance Dampening Time Constant	5 ms	All set-ups	TRUE	-3	Uint8
<b>1-7* Start Adjustments</b>						
1-71	Start Delay	0.0 s	All set-ups	TRUE	-1	Uint16
1-73	Fiving Start	[0] Disabled	All set-ups	FALSE	-	Uint8
<b>1-8* Stop Adjustments</b>						
1-80	Function at Stop	[0] Coast	All set-ups	TRUE	-	Uint8
1-81	Min Speed for Function at Stop [RPM]	ExpressionLimit	All set-ups	TRUE	67	Uint16
1-82	Min Speed for Function at Stop [Hz]	ExpressionLimit	All set-ups	TRUE	-1	Uint16
<b>1-9* Motor Temperature</b>						
1-90	Motor Thermal Protection	[4] ETR trip 1	All set-ups	TRUE	-	Uint8
1-91	Motor External Fan	[0] No	All set-ups	TRUE	-	Uint16
1-93	Thermistor Source	[0] None	All set-ups	TRUE	-	Uint8

### 6.2.3. 2- \* \* Brakes

Par. No. #	Parameter description	Default value	4-set-up	Change during operation	Conversion index	Type
<b>2-0* DC-Brake</b>						
2-00	DC Hold/Preheat Current	50 %	All set-ups	TRUE	0	Uint8
2-01	DC Brake Current	50 %	All set-ups	TRUE	0	Uint16
2-02	DC Braking Time	10.0 s	All set-ups	TRUE	-1	Uint16
2-03	DC Brake Cut In Speed [RPM]	ExpressionLimit	All set-ups	TRUE	67	Uint16
2-04	DC Brake Cut In Speed [Hz]	ExpressionLimit	All set-ups	TRUE	-1	Uint16
<b>2-1* Brake Energy Funct.</b>						
2-10	Brake Function	[0] Off	All set-ups	TRUE	-	Uint8
2-11	Brake Resistor (ohm)	ExpressionLimit	All set-ups	TRUE	0	Uint16
2-12	Brake Power Limit (kW)	ExpressionLimit	All set-ups	TRUE	0	Uint32
2-13	Brake Power Monitoring	[0] Off	All set-ups	TRUE	-	Uint8
2-15	Brake Check	[0] Off	All set-ups	TRUE	-	Uint8
2-16	AC brake Max. Current	100.0 %	All set-ups	TRUE	-1	Uint32
2-17	Over-voltage Control	[2] Enabled	All set-ups	TRUE	-	Uint8

### 6.2.4. 3-\*\* Reference/Ramps

Par. No. #	Parameter description	Default value	4-set-up	Change during operation	Conversion index	Type
<b>3-0* Reference Limits</b>						
3-02	Minimum Reference	ExpressionLimit	All set-ups	TRUE	-3	Int32
3-03	Maximum Reference	ExpressionLimit	All set-ups	TRUE	-3	Int32
3-04	Reference Function	[0] Sum	All set-ups	TRUE	-	UInt8
<b>3-1* References</b>						
3-10	Preset Reference	0.00 %	All set-ups	TRUE	-2	Int16
3-11	Jog Speed [Hz]	ExpressionLimit	All set-ups	TRUE	-1	UInt16
3-13	Reference Site	[0] Linked to Hand / Auto	All set-ups	TRUE	-	UInt8
3-14	Preset Relative Reference	0.00 %	All set-ups	TRUE	-2	Int32
3-15	Reference 1 Source	[1] Analog input 53	All set-ups	TRUE	-	UInt8
3-16	Reference 2 Source	[20] Digital pot.meter	All set-ups	TRUE	-	UInt8
3-17	Reference 3 Source	[0] No function	All set-ups	TRUE	-	UInt8
3-19	Jog Speed [RPM]	ExpressionLimit	All set-ups	TRUE	67	UInt16
<b>3-4* Ramp 1</b>						
3-41	Ramp 1 Ramp Up Time	ExpressionLimit	All set-ups	TRUE	-2	UInt32
3-42	Ramp 1 Ramp Down Time	ExpressionLimit	All set-ups	TRUE	-2	UInt32
<b>3-5* Ramp 2</b>						
3-51	Ramp 2 Ramp Up Time	ExpressionLimit	All set-ups	TRUE	-2	UInt32
3-52	Ramp 2 Ramp Down Time	ExpressionLimit	All set-ups	TRUE	-2	UInt32
<b>3-8* Other Ramps</b>						
3-80	Jog Ramp Time	ExpressionLimit	All set-ups	TRUE	-2	UInt32
3-81	Quick Stop Ramp Time	ExpressionLimit	2 set-ups	TRUE	-2	UInt32
<b>3-9* Digital Pot.Meter</b>						
3-90	Step Size	0.10 %	All set-ups	TRUE	-2	UInt16
3-91	Ramp Time	1.00 s	All set-ups	TRUE	-2	UInt32
3-92	Power Restore	[0] Off	All set-ups	TRUE	-	UInt8
3-93	Maximum Limit	100 %	All set-ups	TRUE	0	Int16
3-94	Minimum Limit	0 %	All set-ups	TRUE	0	Int16
3-95	Ramp Delay	1.000 N/A	All set-ups	TRUE	-3	TimD

### 6.2.5. 4- \* \* Limits/Warnings

Par. No. #	Parameter description	Default value	4-set-up	Change during operation	Conversion index	Type
<b>4-1* Motor Limits</b>						
4-10	Motor Speed Direction	[2] Both directions	All set-ups	FALSE	-	Ujnt8
4-11	Motor Speed Low Limit [RPM]	ExpressionLimit	All set-ups	TRUE	67	Ujnt16
4-12	Motor Speed Low Limit [Hz]	ExpressionLimit	All set-ups	TRUE	-1	Ujnt16
4-13	Motor Speed High Limit [RPM]	ExpressionLimit	All set-ups	TRUE	67	Ujnt16
4-14	Motor Speed High Limit [Hz]	ExpressionLimit	All set-ups	TRUE	-1	Ujnt16
4-16	Torque Limit Motor Mode	110.0 %	All set-ups	TRUE	-1	Ujnt16
4-17	Torque Limit Generator Mode	100.0 %	All set-ups	TRUE	-1	Ujnt16
4-18	Current Limit	ExpressionLimit	All set-ups	TRUE	-1	Ujnt32
4-19	Max Output Frequency	ExpressionLimit	All set-ups	FALSE	-1	Ujnt16
<b>4-5* Adj. Warnings</b>						
4-50	Warning Current Low	0.00 A	All set-ups	TRUE	-2	Ujnt32
4-51	Warning Current High	ImaxVLT (P1637)	All set-ups	TRUE	-2	Ujnt32
4-52	Warning Speed Low	0 RPM	All set-ups	TRUE	67	Ujnt16
4-53	Warning Speed High	outputSpeedHighLimit (P413)	All set-ups	TRUE	67	Ujnt16
4-54	Warning Reference Low	-999999,999 N/A	All set-ups	TRUE	-3	Int32
4-55	Warning Reference High	999999,999 N/A	All set-ups	TRUE	-3	Int32
4-56	Warning Feedback Low	-999999,999 ReferenceFeedbackUnit	All set-ups	TRUE	-3	Int32
4-57	Warning Feedback High	999999,999 ReferenceFeedbackUnit	All set-ups	TRUE	-3	Int32
4-58	Missing Motor Phase Function	[1] On	All set-ups	TRUE	-	Ujnt8
<b>4-6* Speed Bypass</b>						
4-60	Bypass Speed From [RPM]	ExpressionLimit	All set-ups	TRUE	67	Ujnt16
4-61	Bypass Speed From [Hz]	ExpressionLimit	All set-ups	TRUE	-1	Ujnt16
4-62	Bypass Speed To [RPM]	ExpressionLimit	All set-ups	TRUE	67	Ujnt16
4-63	Bypass Speed To [Hz]	ExpressionLimit	All set-ups	TRUE	-1	Ujnt16
4-64	Semi-Auto Bypass Set-up	[0] Off	All set-ups	FALSE	-	Ujnt8

### 6.2.6. 5- \*\* Digital In/Out

Par. No. #	Parameter description	Default value	4-set-up	Change during operation	Conversion index	Type
<b>5-0* Digital I/O mode</b>						
5-00	Digital I/O Mode	[0] PNP - Active at 24V	All set-ups	FALSE	-	Uint8
5-01	Terminal 27 Mode	[0] Input	All set-ups	TRUE	-	Uint8
5-02	Terminal 29 Mode	[0] Input	All set-ups	TRUE	-	Uint8
<b>5-1* Digital Inputs</b>						
5-10	Terminal 18 Digital Input	[8] Start	All set-ups	TRUE	-	Uint8
5-11	Terminal 19 Digital Input	[10] Reversing	All set-ups	TRUE	-	Uint8
5-12	Terminal 27 Digital Input	null	All set-ups	TRUE	-	Uint8
5-13	Terminal 29 Digital Input	[14] Jog	All set-ups	TRUE	-	Uint8
5-14	Terminal 32 Digital Input	[0] No operation	All set-ups	TRUE	-	Uint8
5-15	Terminal 33 Digital Input	[0] No operation	All set-ups	TRUE	-	Uint8
5-16	Terminal X30/2 Digital Input	[0] No operation	All set-ups	TRUE	-	Uint8
5-17	Terminal X30/3 Digital Input	[0] No operation	All set-ups	TRUE	-	Uint8
5-18	Terminal X30/4 Digital Input	[0] No operation	All set-ups	TRUE	-	Uint8
<b>5-3* Digital Outputs</b>						
5-30	Terminal 27 Digital Output	[0] No operation	All set-ups	TRUE	-	Uint8
5-31	Terminal 29 Digital Output	[0] No operation	All set-ups	TRUE	-	Uint8
5-32	Term X30/6 Digi Out (MCB 101)	[0] No operation	All set-ups	TRUE	-	Uint8
5-33	Term X30/7 Digi Out (MCB 101)	[0] No operation	All set-ups	TRUE	-	Uint8
<b>5-4* Relays</b>						
5-40	Function Relay	null	All set-ups	TRUE	-	Uint8
5-41	On Delay, Relay	0.01 s	All set-ups	TRUE	-2	Uint16
5-42	Off Delay, Relay	0.01 s	All set-ups	TRUE	-2	Uint16
<b>5-5* Pulse Input</b>						
5-50	Term. 29 Low Frequency	100 Hz	All set-ups	TRUE	0	Uint32
5-51	Term. 29 High Frequency	100 Hz	All set-ups	TRUE	0	Uint32
5-52	Term. 29 Low Ref./Feedb. Value	0.000 N/A	All set-ups	TRUE	-3	Int32
5-53	Term. 29 High Ref./Feedb. Value	100.000 N/A	All set-ups	TRUE	-3	Int32
5-54	Pulse Filter Time Constant #29	100 ms	All set-ups	FALSE	-3	Uint16
5-55	Term. 33 Low Frequency	100 Hz	All set-ups	TRUE	0	Uint32
5-56	Term. 33 High Frequency	100 Hz	All set-ups	TRUE	0	Uint32
5-57	Term. 33 Low Ref./Feedb. Value	0.000 N/A	All set-ups	TRUE	-3	Uint32
5-58	Term. 33 High Ref./Feedb. Value	100.000 N/A	All set-ups	TRUE	-3	Uint32
5-59	Pulse Filter Time Constant #33	100 ms	All set-ups	FALSE	-3	Uint16

Par. No. #	Parameter description	Default value	4-set-up	Change during operation	Conversion index	Type
<b>5-6* Pulse Output</b>						
5-60	Terminal 27 Pulse Output Variable	[0] No operation	All set-ups	TRUE	-	Ujnt8
5-62	Pulse Output Max Freq #27	5000 Hz	All set-ups	TRUE	0	Ujnt32
5-63	Terminal 29 Pulse Output Variable	[0] No operation	All set-ups	TRUE	-	Ujnt8
5-65	Pulse Output Max Freq #29	5000 Hz	All set-ups	TRUE	0	Ujnt32
5-66	Terminal X30/6 Pulse Output Variable	[0] No operation	All set-ups	TRUE	-	Ujnt8
5-68	Pulse Output Max Freq #X30/6	5000 Hz	All set-ups	TRUE	0	Ujnt32
<b>5-9* Bus Controlled</b>						
5-90	Digital & Relay Bus Control	0 N/A	All set-ups	TRUE	0	Ujnt32
5-93	Pulse Out #27 Bus Control	0.00 %	All set-ups	TRUE	-2	N2
5-94	Pulse Out #27 Timeout Preset	0.00 %	1 set-up	TRUE	-2	Ujnt16
5-95	Pulse Out #29 Bus Control	0.00 %	All set-ups	TRUE	-2	N2
5-96	Pulse Out #29 Timeout Preset	0.00 %	1 set-up	TRUE	-2	Ujnt16
5-97	Pulse Out #X30/6 Bus Control	0.00 %	All set-ups	TRUE	-2	N2
5-98	Pulse Out #X30/6 Timeout Preset	0.00 %	1 set-up	TRUE	-2	Ujnt16



### 6.2.7. 6-\*\* Analog In/Out

Par. No. #	Parameter description	Default value	4-set-up	Change during operation	Conversion index	Type
<b>6-0* Analog I/O Mode</b>						
6-00	Live Zero Timeout Time	10 s	All set-ups	TRUE	0	Uint8
6-01	Live Zero Timeout Function	[0] Off	All set-ups	TRUE	-	Uint8
6-02	Fire Mode Live Zero Timeout Function	null	All set-ups	TRUE	-	Uint8
<b>6-1* Analog Input 53</b>						
6-10	Terminal 53 Low Voltage	0.07 V	All set-ups	TRUE	-2	Int16
6-11	Terminal 53 High Voltage	10.00 V	All set-ups	TRUE	-2	Int16
6-12	Terminal 53 Low Current	4.00 mA	All set-ups	TRUE	-5	Int16
6-13	Terminal 53 High Current	20.00 mA	All set-ups	TRUE	-5	Int16
6-14	Terminal 53 Low Ref./Feedb. Value	0.000 N/A	All set-ups	TRUE	-3	Int32
6-15	Terminal 53 High Ref./Feedb. Value	ExpressionLimit	All set-ups	TRUE	-3	Int32
6-16	Terminal 53 Filter Time Constant	0.001 s	All set-ups	TRUE	-3	Uint16
6-17	Terminal 53 Live Zero	[1] Enabled	All set-ups	TRUE	-	Uint8
<b>6-2* Analog Input 54</b>						
6-20	Terminal 54 Low Voltage	0.07 V	All set-ups	TRUE	-2	Int16
6-21	Terminal 54 High Voltage	10.00 V	All set-ups	TRUE	-2	Int16
6-22	Terminal 54 Low Current	4.00 mA	All set-ups	TRUE	-5	Int16
6-23	Terminal 54 High Current	20.00 mA	All set-ups	TRUE	-5	Int16
6-24	Terminal 54 Low Ref./Feedb. Value	0.000 N/A	All set-ups	TRUE	-3	Int32
6-25	Terminal 54 High Ref./Feedb. Value	100.000 N/A	All set-ups	TRUE	-3	Int32
6-26	Terminal 54 Filter Time Constant	0.001 s	All set-ups	TRUE	-3	Uint16
6-27	Terminal 54 Live Zero	[1] Enabled	All set-ups	TRUE	-	Uint8
<b>6-3* Analog Input X30/11</b>						
6-30	Terminal X30/11 Low Voltage	0.07 V	All set-ups	TRUE	-2	Int16
6-31	Terminal X30/11 High Voltage	10.00 V	All set-ups	TRUE	-2	Int16
6-34	Term. X30/11 Low Ref./Feedb. Value	0.000 N/A	All set-ups	TRUE	-3	Int32
6-35	Term. X30/11 High Ref./Feedb. Value	100.000 N/A	All set-ups	TRUE	-3	Int32
6-36	Term. X30/11 Filter Time Constant	0.001 s	All set-ups	TRUE	-3	Uint16
6-37	Term. X30/11 Live Zero	[1] Enabled	All set-ups	TRUE	-	Uint8
<b>6-4* Analog Input X30/12</b>						
6-40	Terminal X30/12 Low Voltage	0.07 V	All set-ups	TRUE	-2	Int16
6-41	Terminal X30/12 High Voltage	10.00 V	All set-ups	TRUE	-2	Int16
6-44	Term. X30/12 Low Ref./Feedb. Value	0.000 N/A	All set-ups	TRUE	-3	Int32
6-45	Term. X30/12 High Ref./Feedb. Value	100.000 N/A	All set-ups	TRUE	-3	Int32
6-46	Term. X30/12 Filter Time Constant	0.001 s	All set-ups	TRUE	-3	Uint16
6-47	Term. X30/12 Live Zero	[1] Enabled	All set-ups	TRUE	-	Uint8

Par. No. #	Parameter description	Default value	4-set-up	Change during operation	Conversion index	Type
<b>6-5* Analog Output 42</b>						
6-50	Terminal 42 Output	[100] Output frequency	All set-ups	TRUE	-	Uint8
6-51	Terminal 42 Output Min Scale	0.00 %	All set-ups	TRUE	-2	Int16
6-52	Terminal 42 Output Max Scale	100.00 %	All set-ups	TRUE	-2	Int16
6-53	Terminal 42 Output Bus Control	0.00 %	All set-ups	TRUE	-2	N2
6-54	Terminal 42 Output Timeout Preset	0.00 %	1 set-up	TRUE	-2	Uint16
<b>6-6* Analog Output X30/8</b>						
6-60	Terminal X30/8 Output	[0] No operation	All set-ups	TRUE	-	Uint8
6-61	Terminal X30/8 Min. Scale	0.00 %	All set-ups	TRUE	-2	Int16
6-62	Terminal X30/8 Max. Scale	100.00 %	All set-ups	TRUE	-2	Int16
6-63	Terminal X30/8 Output Bus Control	0.00 %	All set-ups	TRUE	-2	N2
6-64	Terminal X30/8 Output Timeout Preset	0.00 %	1 set-up	TRUE	-2	Uint16

### 6.2.8. 8- \* \* Comm. and Options

Par. No. #	Parameter description	Default value	4-set-up	Change during operation	Conversion index	Type
<b>8-0* General Settings</b>						
8-01	Control Site	[0] Digital and ctrl.word null	All set-ups	TRUE	-	Uint8
8-02	Control Source	ExpressionLimit	All set-ups	TRUE	-	Uint8
8-03	Control Timeout Time	[0] Off	1 set-up	TRUE	-1	Uint32
8-04	Control Timeout Function	[1] Resume set-up	1 set-up	TRUE	-	Uint8
8-05	End-of-Timeout Function	[0] Do not reset	1 set-up	TRUE	-	Uint8
8-06	Reset Control Timeout	[0] Disable	All set-ups	TRUE	-	Uint8
8-07	Diagnosis Trigger		2 set-ups	TRUE	-	Uint8
<b>8-1* Control Settings</b>						
8-10	Control Profile	[0] FC profile	All set-ups	TRUE	-	Uint8
8-13	Configurable Status Word STW	[1] Profile Default	All set-ups	TRUE	-	Uint8
<b>8-3* FC Port Settings</b>						
8-30	Protocol	[0] FC	1 set-up	TRUE	-	Uint8
8-31	Address	1 N/A	1 set-up	TRUE	0	Uint8
8-32	Baud Rate	null	1 set-up	TRUE	-	Uint8
8-33	Parity / Stop Bits	null	1 set-up	TRUE	-	Uint8
8-35	Minimum Response Delay	10 ms	1 set-up	TRUE	-3	Uint16
8-36	Max Response Delay	ExpressionLimit	1 set-up	TRUE	-3	Uint16
8-37	Max Inter-Char Delay	ExpressionLimit	1 set-up	TRUE	-5	Uint16
<b>8-4* FC MC protocol set</b>						
8-40	Telegram Selection	[1] Standard telegram 1	2 set-ups	TRUE	-	Uint8
<b>8-5* Digital/Bus</b>						
8-50	Coasting Select	[3] Logic OR	All set-ups	TRUE	-	Uint8
8-52	DC Brake Select	[3] Logic OR	All set-ups	TRUE	-	Uint8
8-53	Start Select	[3] Logic OR	All set-ups	TRUE	-	Uint8
8-54	Reversing Select	[0] Digital input	All set-ups	TRUE	-	Uint8
8-55	Set-up Select	[3] Logic OR	All set-ups	TRUE	-	Uint8
8-56	Preset Reference Select	[3] Logic OR	All set-ups	TRUE	-	Uint8
<b>8-7* BACnet</b>						
8-70	BACnet Device Instance	1 N/A	1 set-up	TRUE	0	Uint32
8-72	MS/TP Max Masters	127 N/A	1 set-up	TRUE	0	Uint8
8-73	MS/TP Max Info Frames	1 N/A	1 set-up	TRUE	0	Uint16
8-74	"I-Am" Service	[0] Send at power-up	1 set-up	TRUE	-	Uint8
8-75	Initialisation Password	0 N/A	1 set-up	TRUE	0	VisStr[20]
<b>8-8* FC Port Diagnostics</b>						
8-80	Bus Message Count	0 N/A	All set-ups	TRUE	0	Uint32
8-81	Bus Error Count	0 N/A	All set-ups	TRUE	0	Uint32
8-82	Slave Message Count	0 N/A	All set-ups	TRUE	0	Uint32
8-83	Slave Error Count	0 N/A	All set-ups	TRUE	0	Uint32
<b>8-9* Bus Jog / Feedback</b>						
8-90	Bus Jog 1 Speed	100 RPM	All set-ups	TRUE	67	Uint16
8-91	Bus Jog 2 Speed	200 RPM	All set-ups	TRUE	67	Uint16
8-94	Bus Feedback 1	0 N/A	1 set-up	TRUE	0	N2
8-95	Bus Feedback 2	0 N/A	1 set-up	TRUE	0	N2
8-96	Bus Feedback 3	0 N/A	1 set-up	TRUE	0	N2

## 6.2.9. 9- \*\* Profibus

Par. No. #	Parameter description	Default value	4-set-up	Change during operation	Conversion index	Type
9-00	Setpoint	0 N/A	All set-ups	TRUE	0	Uint16
9-07	Actual Value	0 N/A	All set-ups	FALSE	0	Uint16
9-15	PCD Write Configuration	ExpressionLimit	2 set-ups	TRUE	-	Uint16
9-16	PCD Read Configuration	ExpressionLimit	2 set-ups	TRUE	-	Uint16
9-18	Node Address	126 N/A	1 set-up	TRUE	0	Uint8
9-22	Telegram Selection	[108] PPO 8	1 set-up	TRUE	-	Uint8
9-23	Parameters for Signals	0	All set-ups	TRUE	-	Uint16
9-27	Parameter Edit	[1] Enabled	2 set-ups	FALSE	-	Uint16
9-28	Process Control	[1] Enable cyclic master	2 set-ups	FALSE	-	Uint8
9-44	Fault Message Counter	0 N/A	All set-ups	TRUE	0	Uint16
9-45	Fault Code	0 N/A	All set-ups	TRUE	0	Uint16
9-47	Fault Number	0 N/A	All set-ups	TRUE	0	Uint16
9-52	Fault Situation Counter	0 N/A	All set-ups	TRUE	0	Uint16
9-53	Profibus Warning Word	0 N/A	All set-ups	TRUE	0	Uint16
9-63	Actual Baud Rate	[255] No baudrate found	All set-ups	TRUE	-	Uint8
9-64	Device Identification	0 N/A	All set-ups	TRUE	0	Uint16
9-65	Profile Number	0 N/A	All set-ups	TRUE	0	OctStr[2]
9-67	Control Word 1	0 N/A	All set-ups	TRUE	0	V2
9-68	Status Word 1	0 N/A	All set-ups	TRUE	0	V2
9-71	Profibus Save Data Values	[0] Off	All set-ups	TRUE	-	Uint8
9-72	ProfibusDriveReset	[0] No action	1 set-up	FALSE	-	Uint8
9-80	Defined Parameters (1)	0 N/A	All set-ups	FALSE	0	Uint16
9-81	Defined Parameters (2)	0 N/A	All set-ups	FALSE	0	Uint16
9-82	Defined Parameters (3)	0 N/A	All set-ups	FALSE	0	Uint16
9-83	Defined Parameters (4)	0 N/A	All set-ups	FALSE	0	Uint16
9-84	Defined Parameters (5)	0 N/A	All set-ups	FALSE	0	Uint16
9-90	Changed Parameters (1)	0 N/A	All set-ups	FALSE	0	Uint16
9-91	Changed Parameters (2)	0 N/A	All set-ups	FALSE	0	Uint16
9-92	Changed Parameters (3)	0 N/A	All set-ups	FALSE	0	Uint16
9-93	Changed Parameters (4)	0 N/A	All set-ups	FALSE	0	Uint16
9-94	Changed Parameters (5)	0 N/A	All set-ups	FALSE	0	Uint16

### 6.2.10. 10- \* \* CAN Fieldbus

Par. No. #	Parameter description	Default value	4-set-up	Change during operation	Conversion index	Type
<b>10-0* Common Settings</b>						
10-00	CAN Protocol	null	2 set-ups	FALSE	-	Uint8
10-01	Baud Rate Select	null	2 set-ups	TRUE	-	Uint8
10-02	MAC ID	ExpressionLimit	2 set-ups	TRUE	0	Uint8
10-05	Readout Transmit Error Counter	0 N/A	All set-ups	TRUE	0	Uint8
10-06	Readout Receive Error Counter	0 N/A	All set-ups	TRUE	0	Uint8
10-07	Readout Bus Off Counter	0 N/A	All set-ups	TRUE	0	Uint8
<b>10-1* DeviceNet</b>						
10-10	Process Data Type Selection	null	All set-ups	TRUE	-	Uint8
10-11	Process Data Config Write	ExpressionLimit	2 set-ups	TRUE	-	Uint16
10-12	Process Data Config Read	ExpressionLimit	2 set-ups	TRUE	-	Uint16
10-13	Warning Parameter	0 N/A	All set-ups	TRUE	0	Uint16
10-14	Net Reference	[0] Off	2 set-ups	TRUE	-	Uint8
10-15	Net Control	[0] Off	2 set-ups	TRUE	-	Uint8
<b>10-2* COS Filters</b>						
10-20	COS Filter 1	0 N/A	All set-ups	FALSE	0	Uint16
10-21	COS Filter 2	0 N/A	All set-ups	FALSE	0	Uint16
10-22	COS Filter 3	0 N/A	All set-ups	FALSE	0	Uint16
10-23	COS Filter 4	0 N/A	All set-ups	FALSE	0	Uint16
<b>10-3* Parameter Access</b>						
10-30	Array Index	0 N/A	2 set-ups	TRUE	0	Uint8
10-31	Store Data Values	[0] Off	All set-ups	TRUE	-	Uint8
10-32	DeviceNet Revision	ExpressionLimit	All set-ups	TRUE	0	Uint16
10-33	Store Always	[0] Off	1 set-up	TRUE	-	Uint8
10-34	DeviceNet Product Code	120 N/A	1 set-up	TRUE	0	Uint16
10-39	DeviceNet F Parameters	0 N/A	All set-ups	TRUE	0	Uint32

### 6.2.11. 11-\*\*-\*\* LonWorks

Par. No. #	Parameter description	Default value	4-set-up	Change during operation	Conversion index	Type
<b>11-0* LonWorks ID</b>						
11-00	Neuron ID	0 N/A	All set-ups	TRUE	0	OctStr[6]
<b>11-1* LON Functions</b>						
11-10	Drive Profile	[0] VSD profile	All set-ups	TRUE	-	UInt8
11-15	LON Warning Word	0 N/A	All set-ups	TRUE	0	UInt16
11-17	XIF Revision	0 N/A	All set-ups	TRUE	0	VisStr[5]
11-18	LonWorks Revision	0 N/A	All set-ups	TRUE	0	VisStr[5]
<b>11-2* LON Param. Access</b>						
11-21	Store Data Values	[0] Off	All set-ups	TRUE	-	UInt8

### 6.2.12. 13- \*\* Smart Logic

Par. No. #	Parameter description	Default value	4-set-up	Change during operation	Conversion index	Type
<b>13-0* SLC Settings</b>						
13-00	SL Controller Mode	null	2 set-ups	TRUE	-	Uint8
13-01	Start Event	null	2 set-ups	TRUE	-	Uint8
13-02	Stop Event	null	2 set-ups	TRUE	-	Uint8
13-03	Reset SLC	[0] Do not reset SLC	All set-ups	TRUE	-	Uint8
<b>13-1* Comparators</b>						
13-10	Comparator Operand	null	2 set-ups	TRUE	-	Uint8
13-11	Comparator Operator	null	2 set-ups	TRUE	-	Uint8
13-12	Comparator Value	ExpressionLimit	2 set-ups	TRUE	-3	Int32
<b>13-2* Timers</b>						
13-20	SL Controller Timer	ExpressionLimit	1 set-up	TRUE	-3	TimD
<b>13-4* Logic Rules</b>						
13-40	Logic Rule Boolean 1	null	2 set-ups	TRUE	-	Uint8
13-41	Logic Rule Operator 1	null	2 set-ups	TRUE	-	Uint8
13-42	Logic Rule Boolean 2	null	2 set-ups	TRUE	-	Uint8
13-43	Logic Rule Operator 2	null	2 set-ups	TRUE	-	Uint8
13-44	Logic Rule Boolean 3	null	2 set-ups	TRUE	-	Uint8
<b>13-5* States</b>						
13-51	SL Controller Event	null	2 set-ups	TRUE	-	Uint8
13-52	SL Controller Action	null	2 set-ups	TRUE	-	Uint8

### 6.2.13. 14- \*\* Special Functions

Par. No. #	Parameter description	Default value	4-set-up	Change during operation	Conversion index	Type
<b>14-0* Inverter Switching</b>						
14-00	Switching Pattern	[0] 60 AVM	All set-ups	TRUE	-	Uint8
14-01	Switching Frequency	null	All set-ups	TRUE	-	Uint8
14-03	Overmodulation	[1] On	All set-ups	FALSE	-	Uint8
14-04	PWM Random	[0] Off	All set-ups	TRUE	-	Uint8
<b>14-1* Mains On/Off</b>						
14-12	Function at Mains Imbalance	[0] Trip	All set-ups	TRUE	-	Uint8
<b>14-2* Reset Functions</b>						
14-20	Reset Mode	[0] Manual reset	All set-ups	TRUE	-	Uint8
14-21	Automatic Restart Time	10 s	All set-ups	TRUE	0	Uint16
14-22	Operation Mode	[0] Normal operation	All set-ups	TRUE	-	Uint8
14-23	Typecode Setting	null	2 set-ups	FALSE	-	Uint16
14-25	Trip Delay at Torque Limit	60 s	All set-ups	TRUE	0	Uint8
14-26	Trip Delay at Inverter Fault	ExpressionLimit	All set-ups	TRUE	0	Uint8
14-28	Production Settings	[0] No action	All set-ups	TRUE	-	Uint8
14-29	Service Code	0 N/A	All set-ups	TRUE	0	Int32
<b>14-3* Current Limit Ctrl.</b>						
14-30	Current Lim Ctrl, Proportional Gain	100 %	All set-ups	FALSE	0	Uint16
14-31	Current Lim Ctrl, Integration Time	0.020 s	All set-ups	FALSE	-3	Uint16
<b>14-4* Energy Optimising</b>						
14-40	VT Level	66 %	All set-ups	FALSE	0	Uint8
14-41	AEO Minimum Magnetisation	40 %	All set-ups	TRUE	0	Uint8
14-42	Minimum AEO Frequency	10 Hz	All set-ups	TRUE	0	Uint8
14-43	Motor Cosphi	ExpressionLimit	All set-ups	TRUE	-2	Uint16
<b>14-5* Environment</b>						
14-50	RFI Filter	[1] On	1 set-up	FALSE	-	Uint8
14-52	Fan Control	[0] Auto	All set-ups	TRUE	-	Uint8
14-53	Fan Monitor	[1] Warning	All set-ups	TRUE	-	Uint8
<b>14-6* Auto Derate</b>						
14-60	Function at Over Temperature	[0] Trip	All set-ups	TRUE	-	Uint8
14-61	Function at Inverter Overload	[0] Trip	All set-ups	TRUE	-	Uint8
14-62	Inv. Overload Derate Current	95 %	All set-ups	TRUE	0	Uint16



### 6.2.14. 15- \*\* FC Information

Par. No. #	Parameter description	Default value	4-set-up	Change during operation	Conversion index	Type
<b>15-0* Operating Data</b>						
15-00	Operating Hours	0 h	All set-ups	FALSE	74	Uint32
15-01	Running Hours	0 h	All set-ups	FALSE	74	Uint32
15-02	kWh Counter	0 kWh	All set-ups	FALSE	75	Uint32
15-03	Power Up's	0 N/A	All set-ups	FALSE	0	Uint32
15-04	Over Temp's	0 N/A	All set-ups	FALSE	0	Uint16
15-05	Over Volt's	0 N/A	All set-ups	FALSE	0	Uint16
15-06	Reset kWh Counter	[0] Do not reset	All set-ups	TRUE	-	Uint8
15-07	Reset Running Hours Counter	[0] Do not reset	All set-ups	TRUE	-	Uint8
15-08	Number of Starts	0 N/A	All set-ups	FALSE	0	Uint32
<b>15-1* Data Log Settings</b>						
15-10	Logging Source	0	2 set-ups	TRUE	-	Uint16
15-11	Logging Interval	ExpressionLimit	2 set-ups	TRUE	-3	TimD
15-12	Trigger Event	[0] False	1 set-up	TRUE	-	Uint8
15-13	Logging Mode	[0] Log always	2 set-ups	TRUE	-	Uint8
15-14	Samples Before Trigger	50 N/A	2 set-ups	TRUE	0	Uint8
<b>15-2* Historic Log</b>						
15-20	Historic Log: Event	0 N/A	All set-ups	FALSE	0	Uint8
15-21	Historic Log: Value	0 N/A	All set-ups	FALSE	0	Uint32
15-22	Historic Log: Time	0 ms	All set-ups	FALSE	-3	Uint32
15-23	Historic Log: Date and Time	ExpressionLimit	All set-ups	FALSE	0	TimeOfDay
<b>15-3* Alarm Log</b>						
15-30	Alarm Log: Error Code	0 N/A	All set-ups	FALSE	0	Uint8
15-31	Alarm Log: Value	0 N/A	All set-ups	FALSE	0	Uint16
15-32	Alarm Log: Time	0 s	All set-ups	FALSE	0	Uint32
15-33	Alarm Log: Date and Time	ExpressionLimit	All set-ups	FALSE	0	TimeOfDay
<b>15-4* Drive Identification</b>						
15-40	FC Type	0 N/A	All set-ups	FALSE	0	VisStr[6]
15-41	Power Section	0 N/A	All set-ups	FALSE	0	VisStr[20]
15-42	Voltage	0 N/A	All set-ups	FALSE	0	VisStr[20]
15-43	Software Version	0 N/A	All set-ups	FALSE	0	VisStr[5]
15-44	Ordered Typecode String	0 N/A	All set-ups	FALSE	0	VisStr[40]
15-45	Actual Typecode String	0 N/A	All set-ups	FALSE	0	VisStr[40]
15-46	Frequency Converter Ordering No	0 N/A	All set-ups	FALSE	0	VisStr[8]
15-47	Power Card Ordering No	0 N/A	All set-ups	FALSE	0	VisStr[8]
15-48	LCP Id No	0 N/A	All set-ups	FALSE	0	VisStr[20]
15-49	SW ID Control Card	0 N/A	All set-ups	FALSE	0	VisStr[20]
15-50	SW ID Power Card	0 N/A	All set-ups	FALSE	0	VisStr[20]
15-51	Frequency Converter Serial Number	0 N/A	All set-ups	FALSE	0	VisStr[10]
15-53	Power Card Serial Number	0 N/A	All set-ups	FALSE	0	VisStr[19]

Par. No. #	Parameter description	Default value	4-set-up	Change during operation	Conversion index	Type
<b>15-6* Option Ident</b>						
15-60	Option Mounted	0 N/A	All set-ups	FALSE	0	VisStr[30]
15-61	Option SW Version	0 N/A	All set-ups	FALSE	0	VisStr[20]
15-62	Option Ordering No	0 N/A	All set-ups	FALSE	0	VisStr[8]
15-63	Option Serial No	0 N/A	All set-ups	FALSE	0	VisStr[18]
15-70	Option in Slot A	0 N/A	All set-ups	FALSE	0	VisStr[30]
15-71	Slot A Option SW Version	0 N/A	All set-ups	FALSE	0	VisStr[20]
15-72	Option in Slot B	0 N/A	All set-ups	FALSE	0	VisStr[30]
15-73	Slot B Option SW Version	0 N/A	All set-ups	FALSE	0	VisStr[20]
15-74	Option in Slot C0	0 N/A	All set-ups	FALSE	0	VisStr[30]
15-75	Slot C0 Option SW Version	0 N/A	All set-ups	FALSE	0	VisStr[20]
15-76	Option in Slot C1	0 N/A	All set-ups	FALSE	0	VisStr[30]
15-77	Slot C1 Option SW Version	0 N/A	All set-ups	FALSE	0	VisStr[20]
<b>15-9* Parameter Info</b>						
15-92	Defined Parameters	0 N/A	All set-ups	FALSE	0	Ujnt16
15-93	Modified Parameters	0 N/A	All set-ups	FALSE	0	Ujnt16
15-99	Parameter Metadata	0 N/A	All set-ups	FALSE	0	Ujnt16

### 6.2.15. 16- \*\* Data Readouts

Par. No. #	Parameter description	Default value	4-set-up	Change during operation	Conversion index	Type
<b>16-0* General Status</b>						
16-00	Control Word	0 N/A	All set-ups	FALSE	0	V2
16-01	Reference [Unit]	0.000 ReferenceFeedbackUnit	All set-ups	FALSE	-3	Int32
16-02	Reference [%]	0.0 %	All set-ups	FALSE	-1	Int16
16-03	Status Word	0 N/A	All set-ups	FALSE	0	V2
16-05	Main Actual Value [%]	0.00 %	All set-ups	FALSE	-2	N2
16-09	Custom Readout	0.00 CustomReadoutUnit	All set-ups	FALSE	-2	Int32
<b>16-1* Motor Status</b>						
16-10	Power [kW]	0.00 kW	All set-ups	FALSE	1	Int32
16-11	Power [hp]	0.00 hp	All set-ups	FALSE	-2	Int32
16-12	Motor Voltage	0.0 V	All set-ups	FALSE	-1	UInt16
16-13	Frequency	0.0 Hz	All set-ups	FALSE	-1	UInt16
16-14	Motor Current	0.00 A	All set-ups	FALSE	-2	Int32
16-15	Frequency [%]	0.00 %	All set-ups	FALSE	-2	N2
16-16	Torque [Nm]	0.0 Nm	All set-ups	FALSE	-1	Int16
16-17	Speed [RPM]	0 RPM	All set-ups	FALSE	67	Int32
16-18	Motor Thermal	0 %	All set-ups	FALSE	0	UInt8
16-22	Torque [%]	0 %	All set-ups	FALSE	0	Int16
<b>16-3* Drive Status</b>						
16-30	DC Link Voltage	0 V	All set-ups	FALSE	0	UInt16
16-32	Brake Energy /s	0.000 kW	All set-ups	FALSE	0	UInt32
16-33	Brake Energy /2 min	0.000 kW	All set-ups	FALSE	0	UInt32
16-34	Heatsink Temp.	0 °C	All set-ups	FALSE	100	UInt8
16-35	Inverter Thermal	0 %	All set-ups	FALSE	0	UInt8
16-36	Inv. Nom. Current	ExpressionLimit	All set-ups	FALSE	-2	UInt32
16-37	Inv. Max. Current	ExpressionLimit	All set-ups	FALSE	-2	UInt32
16-38	SL Controller State	0 N/A	All set-ups	FALSE	0	UInt8
16-39	Control Card Temp.	0 °C	All set-ups	FALSE	100	UInt8
16-40	Logging Buffer Full	[0] No	All set-ups	TRUE	-	UInt8
<b>16-5* Ref. &amp; Feeds.</b>						
16-50	External Reference	0.0 N/A	All set-ups	FALSE	-1	Int16
16-52	Feedback [Unit]	0.000 ProcessCtrlUnit	All set-ups	FALSE	-3	Int32
16-53	Digi Pot Reference	0.00 N/A	All set-ups	FALSE	-2	Int16
16-54	Feedback 1 [Unit]	0.000 ProcessCtrlUnit	All set-ups	FALSE	-3	Int32
16-55	Feedback 2 [Unit]	0.000 ProcessCtrlUnit	All set-ups	FALSE	-3	Int32
16-56	Feedback 3 [Unit]	0.000 ProcessCtrlUnit	All set-ups	FALSE	-3	Int32

Par. No. #	Parameter description	Default value	4-set-up	Change during operation	Conversion index	Type
<b>16-6* Inputs &amp; Outputs</b>						
16-60	Digital Input	0 N/A	All set-ups	FALSE	0	UInt16
16-61	Terminal 53 Switch Setting	[0] Current	All set-ups	FALSE	-	UInt8
16-62	Analog Input 53	0.000 N/A	All set-ups	FALSE	-3	Int32
16-63	Terminal 54 Switch Setting	[0] Current	All set-ups	FALSE	-	UInt8
16-64	Analog Input 54	0.000 N/A	All set-ups	FALSE	-3	Int32
16-65	Analog Output 42 [mA]	0.000 N/A	All set-ups	FALSE	-3	Int16
16-66	Digital Output [bin]	0 N/A	All set-ups	FALSE	0	Int16
16-67	Pulse Input #29 [Hz]	0 N/A	All set-ups	FALSE	0	Int32
16-68	Pulse Input #33 [Hz]	0 N/A	All set-ups	FALSE	0	Int32
16-69	Pulse Output #27 [Hz]	0 N/A	All set-ups	FALSE	0	Int32
16-70	Pulse Output #29 [Hz]	0 N/A	All set-ups	FALSE	0	Int32
16-71	Relay Output [bin]	0 N/A	All set-ups	FALSE	0	Int16
16-72	Counter A	0 N/A	All set-ups	TRUE	0	Int32
16-73	Counter B	0 N/A	All set-ups	TRUE	0	Int32
16-75	Analog In X30/11	0.000 N/A	All set-ups	FALSE	-3	Int32
16-76	Analog In X30/12	0.000 N/A	All set-ups	FALSE	-3	Int32
16-77	Analog Out X30/8 [mA]	0.000 N/A	All set-ups	FALSE	-3	Int16
<b>16-8* Fieldbus &amp; FC Port</b>						
16-80	Fieldbus CTW 1	0 N/A	All set-ups	FALSE	0	V2
16-82	Fieldbus REF 1	0 N/A	All set-ups	FALSE	0	N2
16-84	Comm. Option STW	0 N/A	All set-ups	FALSE	0	V2
16-85	FC Port CTW 1	0 N/A	All set-ups	FALSE	0	V2
16-86	FC Port REF 1	0 N/A	All set-ups	FALSE	0	N2
<b>16-9* Diagnosis Readouts</b>						
16-90	Alarm Word	0 N/A	All set-ups	FALSE	0	UInt32
16-91	Alarm Word 2	0 N/A	All set-ups	FALSE	0	UInt32
16-92	Warning Word	0 N/A	All set-ups	FALSE	0	UInt32
16-93	Warning Word 2	0 N/A	All set-ups	FALSE	0	UInt32
16-94	Ext. Status Word	0 N/A	All set-ups	FALSE	0	UInt32
16-95	Ext. Status Word 2	0 N/A	All set-ups	FALSE	0	UInt32
16-96	Maintenance Word	0 N/A	All set-ups	FALSE	0	UInt32

## 6.2.16. 18- \*\* Data Readouts 2

Par. No. #	Parameter description	Default value	4-set-up	Change during operation	Conversion index	Type
<b>18-0* Maintenance Log</b>						
18-00	Maintenance Log: Item	0 N/A	All set-ups	FALSE	0	Uint8
18-01	Maintenance Log: Action	0 N/A	All set-ups	FALSE	0	Uint8
18-02	Maintenance Log: Time	0 s	All set-ups	FALSE	0	Uint32
18-03	Maintenance Log: Date and Time	ExpressionLimit	All set-ups	FALSE	0	TimeOfDay
<b>18-3* Inputs &amp; Outputs</b>						
18-30	Analog Input X42/1	0.000 N/A	All set-ups	FALSE	-3	Int32
18-31	Analog Input X42/3	0.000 N/A	All set-ups	FALSE	-3	Int32
18-32	Analog Input X42/5	0.000 N/A	All set-ups	FALSE	-3	Int32
18-33	Analog Out X42/7 [V]	0.000 N/A	All set-ups	FALSE	-3	Int16
18-34	Analog Out X42/9 [V]	0.000 N/A	All set-ups	FALSE	-3	Int16
18-35	Analog Out X42/11 [V]	0.000 N/A	All set-ups	FALSE	-3	Int16

## 6.2.17. 20- \*\* FC Closed Loop

Par. No. #	Parameter description	Default value	4-set-up	Change during operation	Conversion index	Type
<b>20-0* Feedback</b>						
20-00	Feedback 1 Source	[2] Analog input 54	All set-ups	TRUE	-	Uint8
20-01	Feedback 1 Conversion	[0] Linear	All set-ups	FALSE	-	Uint8
20-02	Feedback 1 Source Unit	null	All set-ups	TRUE	-	Uint8
20-03	Feedback 2 Source	[0] No function	All set-ups	TRUE	-	Uint8
20-04	Feedback 2 Conversion	[0] Linear	All set-ups	FALSE	-	Uint8
20-05	Feedback 2 Source Unit	null	All set-ups	TRUE	-	Uint8
20-06	Feedback 3 Source	[0] No function	All set-ups	TRUE	-	Uint8
20-07	Feedback 3 Conversion	[0] Linear	All set-ups	FALSE	-	Uint8
20-08	Feedback 3 Source Unit	null	All set-ups	TRUE	-	Uint8
20-12	Reference/Feedback Unit	null	All set-ups	TRUE	-	Uint8
<b>20-2* Feedback &amp; Setpoint</b>						
20-20	Feedback Function	[3] Minimum	All set-ups	TRUE	-	Uint8
20-21	Setpoint 1	0.000 ProcessCtrlUnit	All set-ups	TRUE	-3	Int32
20-22	Setpoint 2	0.000 ProcessCtrlUnit	All set-ups	TRUE	-3	Int32
20-23	Setpoint 3	0.000 ProcessCtrlUnit	All set-ups	TRUE	-3	Int32
<b>20-3* Feedback Adv. Conv.</b>						
20-30	Refrigerant	[0] R22	All set-ups	TRUE	-	Uint8
20-31	User Defined Refrigerant A1	10.0000 N/A	All set-ups	TRUE	-4	Uint32
20-32	User Defined Refrigerant A2	-2250.00 N/A	All set-ups	TRUE	-2	Int32
20-33	User Defined Refrigerant A3	250.000 N/A	All set-ups	TRUE	-3	Uint32
<b>20-8* PID Basic Settings</b>						
20-81	PID Normal/ Inverse Control	[0] Normal	All set-ups	TRUE	-	Uint8
20-82	PID Start Speed [RPM]	ExpressionLimit	All set-ups	TRUE	67	Uint16
20-83	PID Start Speed [Hz]	ExpressionLimit	All set-ups	TRUE	-1	Uint16
20-84	On Reference Bandwidth	5 %	All set-ups	TRUE	0	Uint8
<b>20-9* PID Controller</b>						
20-91	PID Anti Windup	[1] On	All set-ups	TRUE	-	Uint8
20-93	PID Proportional Gain	0.50 N/A	All set-ups	TRUE	-2	Uint16
20-94	PID Integral Time	20.00 s	All set-ups	TRUE	-2	Uint32
20-95	PID Differentiation Time	0.00 s	All set-ups	TRUE	-2	Uint16
20-96	PID Diff. Gain Limit	5.0 N/A	All set-ups	TRUE	-1	Uint16

### 6.2.18. 21- \*\* Ext. Closed Loop

Par. No. #	Parameter description	Default value	4-set-up	Change during operation	Conversion index	Type
<b>21-1* Ext. CL 1 Ref./Fb.</b>						
21-10	Ext. 1 Ref./Feedback Unit	[1] %	All set-ups	TRUE	-	Uint8
21-11	Ext. 1 Minimum Reference	0.000 ExtPID1Unit	All set-ups	TRUE	-3	Int32
21-12	Ext. 1 Maximum Reference	100.000 ExtPID1Unit	All set-ups	TRUE	-3	Int32
21-13	Ext. 1 Reference Source	[0] No function	All set-ups	TRUE	-	Uint8
21-14	Ext. 1 Feedback Source	[0] No function	All set-ups	TRUE	-	Uint8
21-15	Ext. 1 Setpoint	0.000 ExtPID1Unit	All set-ups	TRUE	-3	Int32
21-17	Ext. 1 Reference [Unit]	0.000 ExtPID1Unit	All set-ups	TRUE	-3	Int32
21-18	Ext. 1 Feedback [Unit]	0.000 ExtPID1Unit	All set-ups	TRUE	-3	Int32
21-19	Ext. 1 Output [%]	0 %	All set-ups	TRUE	0	Int32
<b>21-2* Ext. CL 1 PID</b>						
21-20	Ext. 1 Normal/Inverse Control	[0] Normal	All set-ups	TRUE	-	Uint8
21-21	Ext. 1 Proportional Gain	0.01 N/A	All set-ups	TRUE	-2	Uint16
21-22	Ext. 1 Integral Time	10000.00 s	All set-ups	TRUE	-2	Uint32
21-23	Ext. 1 Differentiation Time	0.00 s	All set-ups	TRUE	-2	Uint16
21-24	Ext. 1 Dif. Gain Limit	5.0 N/A	All set-ups	TRUE	-1	Uint16
<b>21-3* Ext. CL 2 Ref./Fb.</b>						
21-30	Ext. 2 Ref./Feedback Unit	[1] %	All set-ups	TRUE	-	Uint8
21-31	Ext. 2 Minimum Reference	0.000 ExtPID2Unit	All set-ups	TRUE	-3	Int32
21-32	Ext. 2 Maximum Reference	100.000 ExtPID2Unit	All set-ups	TRUE	-3	Int32
21-33	Ext. 2 Reference Source	[0] No function	All set-ups	TRUE	-	Uint8
21-34	Ext. 2 Feedback Source	[0] No function	All set-ups	TRUE	-	Uint8
21-35	Ext. 2 Setpoint	0.000 ExtPID2Unit	All set-ups	TRUE	-3	Int32
21-37	Ext. 2 Reference [Unit]	0.000 ExtPID2Unit	All set-ups	TRUE	-3	Int32
21-38	Ext. 2 Feedback [Unit]	0.000 ExtPID2Unit	All set-ups	TRUE	-3	Int32
21-39	Ext. 2 Output [%]	0 %	All set-ups	TRUE	0	Int32
<b>21-4* Ext. CL 2 PID</b>						
21-40	Ext. 2 Normal/Inverse Control	[0] Normal	All set-ups	TRUE	-	Uint8
21-41	Ext. 2 Proportional Gain	0.01 N/A	All set-ups	TRUE	-2	Uint16
21-42	Ext. 2 Integral Time	10000.00 s	All set-ups	TRUE	-2	Uint32
21-43	Ext. 2 Differentiation Time	0.00 s	All set-ups	TRUE	-2	Uint16
21-44	Ext. 2 Dif. Gain Limit	5.0 N/A	All set-ups	TRUE	-1	Uint16
<b>21-5* Ext. CL 3 Ref./Fb.</b>						
21-50	Ext. 3 Ref./Feedback Unit	[1] %	All set-ups	TRUE	-	Uint8
21-51	Ext. 3 Minimum Reference	0.000 ExtPID3Unit	All set-ups	TRUE	-3	Int32
21-52	Ext. 3 Maximum Reference	100.000 ExtPID3Unit	All set-ups	TRUE	-3	Int32
21-53	Ext. 3 Reference Source	[0] No function	All set-ups	TRUE	-	Uint8
21-54	Ext. 3 Feedback Source	[0] No function	All set-ups	TRUE	-	Uint8
21-55	Ext. 3 Setpoint	0.000 ExtPID3Unit	All set-ups	TRUE	-3	Int32
21-57	Ext. 3 Reference [Unit]	0.000 ExtPID3Unit	All set-ups	TRUE	-3	Int32
21-58	Ext. 3 Feedback [Unit]	0.000 ExtPID3Unit	All set-ups	TRUE	-3	Int32
21-59	Ext. 3 Output [%]	0 %	All set-ups	TRUE	0	Int32

6

Par. No. #	Parameter description	Default value	4-set-up	Change during operation	Conversion index	Type
<b>21-6*</b>	<b>Ext. CL 3 PID</b>					
21-60	Ext. 3 Normal/Inverse Control	[0] Normal	All set-ups	TRUE	-	Uint8
21-61	Ext. 3 Proportional Gain	0.01 N/A	All set-ups	TRUE	-2	Uint16
21-62	Ext. 3 Integral Time	10000.00 s	All set-ups	TRUE	-2	Uint32
21-63	Ext. 3 Differentiation Time	0.00 s	All set-ups	TRUE	-2	Uint16
21-64	Ext. 3 Dif. Gain Limit	5.0 N/A	All set-ups	TRUE	-1	Uint16



### 6.2.19. 22- \*\* Application Functions

Par. No. #	Parameter description	Default value	4-set-up	Change during operation	Conversion index	Type
<b>22-0* Miscellaneous</b>						
22-00	External Interlock Delay	0 s	All set-ups	TRUE	0	Ujnt16
<b>22-2* No-Flow Detection</b>						
22-20	Low Power Auto Set-up	[0] Off	All set-ups	FALSE	-	Ujnt8
22-21	Low Power Detection	[0] Disabled	All set-ups	TRUE	-	Ujnt8
22-22	Low Speed Detection	[0] Disabled	All set-ups	TRUE	-	Ujnt8
22-23	No-Flow Function	[0] Off	All set-ups	TRUE	-	Ujnt8
22-24	No-Flow Delay	10 s	All set-ups	TRUE	0	Ujnt16
22-26	Dry Pump Function	[0] Off	All set-ups	TRUE	-	Ujnt8
22-27	Dry Pump Delay	10 s	All set-ups	TRUE	0	Ujnt16
<b>22-3* No-Flow Power Tuning</b>						
22-30	No-Flow Power	0.00 kW	All set-ups	TRUE	1	Ujnt32
22-31	Power Correction Factor	100 %	All set-ups	TRUE	0	Ujnt16
22-32	Low Speed [RPM]	ExpressionLimit	All set-ups	TRUE	67	Ujnt16
22-33	Low Speed [Hz]	ExpressionLimit	All set-ups	TRUE	-1	Ujnt16
22-34	Low Speed Power [kW]	ExpressionLimit	All set-ups	TRUE	1	Ujnt32
22-35	Low Speed Power [HP]	ExpressionLimit	All set-ups	TRUE	-2	Ujnt32
22-36	High Speed [RPM]	ExpressionLimit	All set-ups	TRUE	67	Ujnt16
22-37	High Speed [Hz]	ExpressionLimit	All set-ups	TRUE	-1	Ujnt16
22-38	High Speed Power [kW]	ExpressionLimit	All set-ups	TRUE	1	Ujnt32
22-39	High Speed Power [HP]	ExpressionLimit	All set-ups	TRUE	-2	Ujnt32
<b>22-4* Sleep Mode</b>						
22-40	Minimum Run Time	10 s	All set-ups	TRUE	0	Ujnt16
22-41	Minimum Sleep Time	10 s	All set-ups	TRUE	0	Ujnt16
22-42	Wake-up Speed [RPM]	ExpressionLimit	All set-ups	TRUE	67	Ujnt16
22-43	Wake-up Speed [Hz]	ExpressionLimit	All set-ups	TRUE	-1	Ujnt16
22-44	Wake-up Ref./FB Difference	10 %	All set-ups	TRUE	0	Int8
22-45	Setpoint Boost	0 %	All set-ups	TRUE	0	Int8
22-46	Maximum Boost Time	60 s	All set-ups	TRUE	0	Ujnt16
<b>22-5* End of Curve</b>						
22-50	End of Curve Function	[0] Off	All set-ups	TRUE	-	Ujnt8
22-51	End of Curve Delay	10 s	All set-ups	TRUE	0	Ujnt16
<b>22-6* Broken Belt Detection</b>						
22-60	Broken Belt Function	[0] Off	All set-ups	TRUE	-	Ujnt8
22-61	Broken Belt Torque	10 %	All set-ups	TRUE	0	Ujnt8
22-62	Broken Belt Delay	10 s	All set-ups	TRUE	0	Ujnt16
<b>22-7* Short Cycle Protection</b>						
22-75	Short Cycle Protection	[0] Disabled	All set-ups	TRUE	-	Ujnt8
22-76	Interval between Starts	start_to_start_min_on_time (P2277)	All set-ups	TRUE	0	Ujnt16
22-77	Minimum Run Time	0 s	All set-ups	TRUE	0	Ujnt16

Par. No. #	Parameter description	Default value	4-set-up	Change during operation	Conversion index	Type
<b>22-8* Flow Compensation</b>						
22-80	Flow Compensation	[0] Disabled	All set-ups	TRUE	-	UInt8
22-81	Square-linear Curve Approximation	100 %	All set-ups	TRUE	0	UInt8
22-82	Work Point Calculation	[0] Disabled	All set-ups	TRUE	-	UInt8
22-83	Speed at No-Flow [RPM]	ExpressionLimit	All set-ups	TRUE	67	UInt16
22-84	Speed at No-Flow [Hz]	ExpressionLimit	All set-ups	TRUE	-1	UInt16
22-85	Speed at Design Point [RPM]	ExpressionLimit	All set-ups	TRUE	67	UInt16
22-86	Speed at Design Point [Hz]	ExpressionLimit	All set-ups	TRUE	-1	UInt16
22-87	Pressure at No-Flow Speed	0.000 N/A	All set-ups	TRUE	-3	Int32
22-88	Pressure at Rated Speed	999999.999 N/A	All set-ups	TRUE	-3	Int32
22-89	Flow at Design Point	0.000 N/A	All set-ups	TRUE	-3	Int32
22-90	Flow at Rated Speed	0.000 N/A	All set-ups	TRUE	-3	Int32

### 6.2.20. 23- \*\* Timed Actions

Par. No. #	Parameter description	Default value	4-set-up	Change during operation	Conversion index	Type
<b>23-0* Timed Actions</b>						
23-00	ON Time	ExpressionLimit	2 set-ups	TRUE	0	TimeOfDay- WoDate
23-01	ON Action	[0] Disabled	2 set-ups	TRUE	-	Uint8
23-02	OFF Time	ExpressionLimit	2 set-ups	TRUE	0	TimeOfDay- WoDate
23-03	OFF Action	[0] Disabled	2 set-ups	TRUE	-	Uint8
23-04	Occurrence	[0] All days	2 set-ups	TRUE	-	Uint8
<b>23-1* Maintenance</b>						
23-10	Maintenance Item	[1] Motor bearings	1 set-up	TRUE	-	Uint8
23-11	Maintenance Action	[1] Lubricate	1 set-up	TRUE	-	Uint8
23-12	Maintenance Time Base	[0] Disabled	1 set-up	TRUE	-	Uint8
23-13	Maintenance Time Interval	1 h	1 set-up	TRUE	74	Uint32
23-14	Maintenance Date and Time	ExpressionLimit	1 set-up	TRUE	0	TimeOfDay
<b>23-1* Maintenance Reset</b>						
23-15	Reset Maintenance Word	[0] Do not reset	All set-ups	TRUE	-	Uint8
<b>23-5* Energy Log</b>						
23-50	Energy Log Resolution	[5] Last 24 Hours	2 set-ups	TRUE	-	Uint8
23-51	Period Start	ExpressionLimit	2 set-ups	TRUE	0	TimeOfDay
23-53	Energy Log	0 N/A	All set-ups	TRUE	0	Uint32
23-54	Reset Energy Log	[0] Do not reset	All set-ups	TRUE	-	Uint8
<b>23-6* Trending</b>						
23-60	Trend Variable	[0] Power [kW]	2 set-ups	TRUE	-	Uint8
23-61	Continuous Bin Data	0 N/A	All set-ups	TRUE	0	Uint32
23-62	Timed Bin Data	0 N/A	All set-ups	TRUE	0	Uint32
23-63	Timed Period Start	ExpressionLimit	2 set-ups	TRUE	0	TimeOfDay
23-64	Timed Period Stop	ExpressionLimit	2 set-ups	TRUE	0	TimeOfDay
23-65	Minimum Bin Value	ExpressionLimit	2 set-ups	TRUE	0	Uint8
23-66	Reset Continuous Bin Data	[0] Do not reset	All set-ups	TRUE	-	Uint8
23-67	Reset Timed Bin Data	[0] Do not reset	All set-ups	TRUE	-	Uint8
<b>23-8* Payback Counter</b>						
23-80	Power Reference Factor	100 %	2 set-ups	TRUE	0	Uint8
23-81	Energy Cost	1.00 N/A	2 set-ups	TRUE	-2	Uint32
23-82	Investment	0 N/A	2 set-ups	TRUE	0	Uint32
23-83	Energy Savings	0 kWh	All set-ups	TRUE	75	Uint32
23-84	Cost Savings	0 N/A	All set-ups	TRUE	0	Uint32

## 6.2.21. 25- \*\* Cascade Controller

Par. No. #	Parameter description	Default value	4-set-up	Change during operation	Conversion index	Type
<b>25-0* System Settings</b>						
25-00	Cascade Controller	[0] Disabled	2 set-ups	FALSE	-	Uint8
25-02	Motor Start	[0] Direct on Line	2 set-ups	FALSE	-	Uint8
25-04	Pump Cycling	[0] Disabled	All set-ups	TRUE	-	Uint8
25-05	Fixed Lead Pump	[1] Yes	2 set-ups	FALSE	-	Uint8
25-06	Number of Pumps	2 N/A	2 set-ups	FALSE	0	Uint8
<b>25-2* Bandwidth Settings</b>						
25-20	Staging Bandwidth	10 %	All set-ups	TRUE	0	Uint8
25-21	Override Bandwidth	100 %	All set-ups	TRUE	0	Uint8
25-22	Fixed Speed Bandwidth	casco_staging_bandwidth (P2520)	All set-ups	TRUE	0	Uint8
25-23	SBW Staging Delay	15 s	All set-ups	TRUE	0	Uint16
25-24	SBW Destaging Delay	15 s	All set-ups	TRUE	0	Uint16
25-25	OBW Time	10 s	All set-ups	TRUE	0	Uint16
25-26	Destage At No-Flow	[0] Disabled	All set-ups	TRUE	-	Uint8
25-27	Stage Function	[1] Enabled	All set-ups	TRUE	-	Uint8
25-28	Stage Function Time	15 s	All set-ups	TRUE	0	Uint16
25-29	Destage Function	[1] Enabled	All set-ups	TRUE	-	Uint8
25-30	Destage Function Time	15 s	All set-ups	TRUE	0	Uint16
<b>25-4* Staging Settings</b>						
25-40	Ramp Down Delay	10.0 s	All set-ups	TRUE	-1	Uint16
25-41	Ramp Up Delay	2.0 s	All set-ups	TRUE	-1	Uint16
25-42	Staging Threshold	ExpressionLimit	All set-ups	TRUE	0	Uint8
25-43	Destaging Threshold	ExpressionLimit	All set-ups	TRUE	0	Uint8
25-44	Staging Speed [RPM]	0 RPM	All set-ups	TRUE	67	Uint16
25-45	Staging Speed [Hz]	0.0 Hz	All set-ups	TRUE	-1	Uint16
25-46	Destaging Speed [RPM]	0 RPM	All set-ups	TRUE	67	Uint16
25-47	Destaging Speed [Hz]	0.0 Hz	All set-ups	TRUE	-1	Uint16
<b>25-5* Alternation Settings</b>						
25-50	Lead Pump Alternation	[0] Off	All set-ups	TRUE	-	Uint8
25-51	Alternation Event	[0] External	All set-ups	TRUE	-	Uint8
25-52	Alternation Time Interval	24 h	All set-ups	TRUE	74	Uint16
25-53	Alternation Timer Value	0 N/A	All set-ups	TRUE	0	VisStr[7]
25-54	Alternation Predefined Time	ExpressionLimit	All set-ups	TRUE	0	TimeOfDay-
25-55	Alternate if Load < 50%	[1] Enabled	All set-ups	TRUE	-	Uint8
25-56	Staging Mode at Alternation	[0] Slow	All set-ups	TRUE	-	Uint8
25-58	Run Next Pump Delay	0.1 s	All set-ups	TRUE	-1	Uint16
25-59	Run on Mains Delay	0.5 s	All set-ups	TRUE	-1	Uint16

Par. No. #	Parameter description	Default value	4-set-up	Change during operation	Conversion index	Type
<b>25-8* Status</b>						
25-80	Cascade Status	0 N/A	All set-ups	TRUE	0	VisStr[25]
25-81	Pump Status	0 N/A	All set-ups	TRUE	0	VisStr[25]
25-82	Lead Pump	0 N/A	All set-ups	TRUE	0	Uint8
25-83	Relay Status	0 N/A	All set-ups	TRUE	0	VisStr[4]
25-84	Pump ON Time	0 h	All set-ups	TRUE	74	Uint32
25-85	Relay ON Time	0 h	All set-ups	TRUE	74	Uint32
25-86	Reset Relay Counters	[0] Do not reset	All set-ups	TRUE	-	Uint8
<b>25-9* Service</b>						
25-90	Pump Interlock	[0] Off	All set-ups	TRUE	-	Uint8
25-91	Manual Alternation	0 N/A	All set-ups	TRUE	0	Uint8

## 6.2.22. 26- \*\* Analog I/O Option MCB 109

Par. No. #	Parameter description	Default value	4-set-up	Change during operation	Conversion index	Type
<b>26-0* Analog I/O Mode</b>						
26-00	Terminal X42/1 Mode	[1] Voltage	All set-ups	TRUE	-	UInt8
26-01	Terminal X42/3 Mode	[1] Voltage	All set-ups	TRUE	-	UInt8
26-02	Terminal X42/5 Mode	[1] Voltage	All set-ups	TRUE	-	UInt8
<b>26-1* Analog Input X42/1</b>						
26-10	Terminal X42/1 Low Voltage	0.07 V	All set-ups	TRUE	-2	Int16
26-11	Terminal X42/1 High Voltage	10.00 V	All set-ups	TRUE	-2	Int16
26-14	Term. X42/1 Low Ref./Feedb. Value	0.000 N/A	All set-ups	TRUE	-3	Int32
26-15	Term. X42/1 High Ref./Feedb. Value	100.000 N/A	All set-ups	TRUE	-3	Int32
26-16	Term. X42/1 Filter Time Constant	0.001 s	All set-ups	TRUE	-3	UInt16
26-17	Term. X42/1 Live Zero	[1] Enabled	All set-ups	TRUE	-	UInt8
<b>26-2* Analog Input X42/3</b>						
26-20	Terminal X42/3 Low Voltage	0.07 V	All set-ups	TRUE	-2	Int16
26-21	Terminal X42/3 High Voltage	10.00 V	All set-ups	TRUE	-2	Int16
26-24	Term. X42/3 Low Ref./Feedb. Value	0.000 N/A	All set-ups	TRUE	-3	Int32
26-25	Term. X42/3 High Ref./Feedb. Value	100.000 N/A	All set-ups	TRUE	-3	Int32
26-26	Term. X42/3 Filter Time Constant	0.001 s	All set-ups	TRUE	-3	UInt16
26-27	Term. X42/3 Live Zero	[1] Enabled	All set-ups	TRUE	-	UInt8
<b>26-3* Analog Input X42/5</b>						
26-30	Terminal X42/5 Low Voltage	0.07 V	All set-ups	TRUE	-2	Int16
26-31	Terminal X42/5 High Voltage	10.00 V	All set-ups	TRUE	-2	Int16
26-34	Term. X42/5 Low Ref./Feedb. Value	0.000 N/A	All set-ups	TRUE	-3	Int32
26-35	Term. X42/5 High Ref./Feedb. Value	100.000 N/A	All set-ups	TRUE	-3	Int32
26-36	Term. X42/5 Filter Time Constant	0.001 s	All set-ups	TRUE	-3	UInt16
26-37	Term. X42/5 Live Zero	[1] Enabled	All set-ups	TRUE	-	UInt8
<b>26-4* Analog Output X42/7</b>						
26-40	Terminal X42/7 Output	[0] No operation	All set-ups	TRUE	-	UInt8
26-41	Terminal X42/7 Min. Scale	0.00 %	All set-ups	TRUE	-2	Int16
26-42	Terminal X42/7 Max. Scale	100.00 %	All set-ups	TRUE	-2	Int16
26-43	Terminal X42/7 Output Bus Control	0.00 %	All set-ups	TRUE	-2	N2
26-44	Terminal X42/7 Output Timeout Preset	0.00 %	1 set-up	TRUE	-2	UInt16
<b>26-5* Analog Output X42/9</b>						
26-50	Terminal X42/9 Output	[0] No operation	All set-ups	TRUE	-	UInt8
26-51	Terminal X42/9 Min. Scale	0.00 %	All set-ups	TRUE	-2	Int16
26-52	Terminal X42/9 Max. Scale	100.00 %	All set-ups	TRUE	-2	Int16
26-53	Terminal X42/9 Output Bus Control	0.00 %	All set-ups	TRUE	-2	N2
26-54	Terminal X42/9 Output Timeout Preset	0.00 %	1 set-up	TRUE	-2	UInt16
<b>26-6* Analog Output X42/11</b>						
26-60	Terminal X42/11 Output	[0] No operation	All set-ups	TRUE	-	UInt8
26-61	Terminal X42/11 Min. Scale	0.00 %	All set-ups	TRUE	-2	Int16
26-62	Terminal X42/11 Max. Scale	100.00 %	All set-ups	TRUE	-2	Int16
26-63	Terminal X42/11 Output Bus Control	0.00 %	All set-ups	TRUE	-2	N2
26-64	Terminal X42/11 Output Timeout Preset	0.00 %	1 set-up	TRUE	-2	UInt16







## 7. Troubleshooting

### 7.1. Alarms and warnings

A warning or an alarm is signalled by the relevant LED on the front of the frequency converter and indicated by a code on the display.

A warning remains active until its cause is no longer present. Under certain circumstances operation of the motor may still be continued. Warning messages may be critical, but are not necessarily so.

In the event of an alarm, the frequency converter will have tripped. Alarms must be reset to restart operation once their cause has been rectified. This may be done in four ways:

1. By using the [RESET] control button on the LCP control panel.
2. Via a digital input with the "Reset" function.
3. Via serial communication/optional fieldbus.
4. By resetting automatically using the [Auto Reset] function, which is a default setting for VLT HVAC Drive. see par. 14-20 Reset Mode in *VLT HVAC Drive Programming Guide*

**NB!**

After a manual reset using the [RESET] button on the LCP, the [AUTO ON] button must be pressed to restart the motor.

If an alarm cannot be reset, the reason may be that its cause has not been rectified, or the alarm is trip-locked (see also table on following page).

Alarms that are trip-locked offer additional protection, means that the mains supply must be switched off before the alarm can be reset. After being switched back on, the frequency converter is no longer blocked and may be reset as described above once the cause has been rectified.

Alarms that are not trip-locked can also be reset using the automatic reset function in parameter 14-20 (Warning: automatic wake-up is possible!)

If a warning and alarm is marked against a code in the table on the following page, this means that either a warning occurs before an alarm, or it can be specified whether it is a warning or an alarm that is to be displayed for a given fault.

This is possible, for instance, in parameter 1-90 *Motor Thermal Protection*. After an alarm or trip, the motor carries on coasting, and the alarm and warning flash on the frequency converter. Once the problem has been rectified, only the alarm continues flashing.

No.	Description	Warning	Alarm/Trip	Alarm/Trip Lock	Parameter Reference
1	10 Volts low	X			
2	Live zero error	(X)	(X)		6-01
3	No motor	(X)			1-80
4	Mains phase loss	(X)	(X)	(X)	14-12
5	DC link voltage high	X			
6	DC link voltage low	X			
7	DC over voltage	X	X		
8	DC under voltage	X	X		
9	Inverter overloaded	X	X		
10	Motor ETR over temperature	(X)	(X)		1-90
11	Motor thermistor over temperature	(X)	(X)		1-90
12	Torque limit	X	X		
13	Over Current	X	X	X	
14	Earth fault	X	X	X	
15	Hardware mesh mash		X	X	
16	Short Circuit		X	X	
17	Control word timeout	(X)	(X)		8-04
25	Brake resistor short-circuited	X			
26	Brake resistor power limit	(X)	(X)		2-13
27	Brake chopper short-circuited	X	X		
28	Brake check	(X)	(X)		2-15
29	Power board over temp	X	X	X	
30	Motor phase U missing	(X)	(X)	(X)	4-58
31	Motor phase V missing	(X)	(X)	(X)	4-58
32	Motor phase W missing	(X)	(X)	(X)	4-58
33	Inrush fault		X	X	
34	Fieldbus communication fault	X	X		
38	Internal fault		X	X	
47	24 V supply low	X	X	X	
48	1.8 V supply low		X	X	
50	AMA calibration failed		X		
51	AMA check $U_{nom}$ and $I_{nom}$		X		
52	AMA low $I_{nom}$		X		
53	AMA motor too big		X		
54	AMA motor too small		X		
55	AMA parameter out of range		X		
56	AMA interrupted by user		X		
57	AMA timeout		X		
58	AMA internal fault	X	X		
59	Current limit	X			
61	Tracking Error	(X)	(X)		4-30
62	Output Frequency at Maximum Limit	X			
64	Voltage Limit	X			
65	Control Board Over-temperature	X	X	X	
66	Heat sink Temperature Low	X			
67	Option Configuration has Changed		X		
68	Safe Stop Activated		X		
80	Drive Initialised to Default Value		X		

Table 7.1: Alarm/Warning code list

(X) Dependent on parameter

<i>LED indication</i>	
Warning	yellow
Alarm	flashing red
Trip locked	yellow and red

Alarm Word and Extended Status Word						
Bit	Hex	Dec	Alarm Word	Warning Word	Extended Word	Status
0	00000001	1	Brake Check	Brake Check	Ramping	
1	00000002	2	Pwr. Card Temp	Pwr. Card Temp	AMA Running	
2	00000004	4	Earth Fault	Earth Fault	Start CW/CCW	
3	00000008	8	Ctrl.Card Temp	Ctrl.Card Temp	Slow Down	
4	00000010	16	Ctrl. Word TO	Ctrl. Word TO	Catch Up	
5	00000020	32	Over Current	Over Current	Feedback High	
6	00000040	64	Torque Limit	Torque Limit	Feedback Low	
7	00000080	128	Motor Th Over	Motor Th Over	Output Current High	
8	00000100	256	Motor ETR Over	Motor ETR Over	Output Current Low	
9	00000200	512	Inverter Overld.	Inverter Overld.	Output Freq High	
10	00000400	1024	DC under Volt	DC under Volt	Output Freq Low	
11	00000800	2048	DC over Volt	DC over Volt	Brake Check OK	
12	00001000	4096	Short Circuit	DC Voltage Low	Braking Max	
13	00002000	8192	Inrush Fault	DC Voltage High	Braking	
14	00004000	16384	Mains ph. Loss	Mains ph. Loss	Out of Speed Range	
15	00008000	32768	AMA Not OK	No Motor	OVC Active	
16	00010000	65536	Live Zero Error	Live Zero Error		
17	00020000	131072	Internal Fault	10V Low		
18	00040000	262144	Brake Overload	Brake Overload		
19	00080000	524288	U phase Loss	Brake Resistor		
20	00100000	1048576	V phase Loss	Brake IGBT		
21	00200000	2097152	W phase Loss	Speed Limit		
22	00400000	4194304	Fieldbus Fault	Fieldbus Fault		
23	00800000	8388608	24 V Supply Low	24V Supply Low		
24	01000000	16777216	Mains Failure	Mains Failure		
25	02000000	33554432	1.8V Supply Low	Current Limit		
26	04000000	67108864	Brake Resistor	Low Temp		
27	08000000	134217728	Brake IGBT	Voltage Limit		
28	10000000	268435456	Option Change	Unused		
29	20000000	536870912	Drive Initialised	Unused		
30	40000000	1073741824	Safe Stop	Unused		

Table 7.2: Description of Alarm Word, Warning Word and Extended Status Word

The alarm words, warning words and extended status words can be read out via serial bus or optional fieldbus for diagnosis. See also par. 16-90, 16-92 and 16-94.

### 7.1.1. Warning/Alarm list

#### WARNING 1

##### 10 Volts low:

The 10 V voltage from terminal 50 on the control card is below 10 V.

Remove some of the load from terminal 50, as the 10 V supply is overloaded. Max. 15 mA or minimum 590 ohm.

#### WARNING/ALARM 2

##### Live zero error:

The signal on terminal 53 or 54 is less than 50% of the value set in par. 6-10, 6-12, 6-20, or 6-22 respectively.

#### WARNING/ALARM 3

##### No motor:

No motor has been connected to the output of the frequency converter.

#### WARNING/ALARM 4

##### Mains phase loss:

A phase is missing on the supply side, or the mains voltage imbalance is too high.

This message also appears in case of a fault in the input rectifier on the frequency converter.

Check the supply voltage and supply currents to the frequency converter.

#### WARNING 5

##### DC link voltage high:

The intermediate circuit voltage (DC) is higher than the overvoltage limit of the control system. The frequency converter is still active.

**WARNING 6**

**DC link voltage low**

The intermediate circuit voltage (DC) is below the undervoltage limit of the control system. The frequency converter is still active.

**WARNING/ALARM 7**

**DC over voltage:**

If the intermediate circuit voltage exceeds the limit, the frequency converter trips after a time.

Possible corrections:

- Connect a brake resistor
- Extend the ramp time
- Activate functions in par. 2-10
- Increase par. 14-26

Connect a brake resistor. Extend the ramp time

Alarm/warning limits:			
Voltage ranges	3 x 200 - 240 V	3 x 380 - 480 V	3 x 525 - 600 V
	[VDC]	[VDC]	[VDC]
Undervoltage	185	373	532
Voltage warning low	205	410	585
Voltage warning high (w/o brake - w/brake)	390/405	810/840	943/965
Overvoltage	410	855	975

The voltages stated are the intermediate circuit voltage of the frequency converter with a tolerance of ± 5 %. The corresponding mains voltage is the intermediate circuit voltage (DC-link) divided by 1.35

**WARNING/ALARM 8**

**DC under voltage:**

If the intermediate circuit voltage (DC) drops below the "voltage warning low" limit (see table above), the frequency converter checks if 24 V backup supply is connected.

If no 24 V backup supply is connected, the frequency converter trips after a given time depending on the unit.

To check whether the supply voltage matches the frequency converter, see *Specifications*.

**WARNING/ALARM 9**

**Inverter overloaded:**

The frequency converter is about to cut out because of an overload (too high current for too long). The counter for electronic, thermal

inverter protection gives a warning at 98% and trips at 100%, while giving an alarm. Reset cannot be performed before counter is below 90%.

The fault is that the frequency converter is overloaded by more than 100% for too long.

**WARNING/ALARM 10**

**Motor ETR over temperature:**

According to the electronic thermal protection (ETR), the motor is too hot. It can be chosen if the frequency converter is to give a warning or an alarm when the counter reaches 100% in par. 1-90. The fault is that the motor is overloaded by more than 100% for too long. Check that the motor par. 1-24 is set correctly.

**WARNING/ALARM 11**

**Motor thermistor over temp:**

The thermistor or the thermistor connection is disconnected. Choose if the frequency converter is to give a warning or an alarm when the counter reaches 100% in par. 1-90. Check that the thermistor is connected correctly between terminal 53 or 54 (analog voltage input) and terminal 50 (+ 10 Volts supply), or between terminal 18 or 19 (digital input PNP only) and terminal 50. If a KTY sensor is used, check for correct connection between terminal 54 and 55.

**WARNING/ALARM 12**

**Torque limit:**

The torque is higher than the value in par. 4-16 (in motor operation) or the torque is higher than the value in par. 4-17 (in regenerative operation).

**WARNING/ALARM 13****Over Current:**

The inverter peak current limit (approx. 200% of the rated current) is exceeded. The warning will last approx. 8-12 sec., then the frequency converter trips and issues an alarm. Turn off the frequency converter and check if the motor shaft can be turned and if the motor size matches the frequency converter.

**ALARM 14****Earth fault:**

There is a discharge from the output phases to earth, either in the cable between the frequency converter and the motor or in the motor itself.

Turn off the frequency converter and remove the earth fault.

**ALARM 15****In-complete hardware:**

A fitted option is not handled by the present control board (hardware or software).

**ALARM 16****Short-circuit:**

There is short-circuiting in the motor or on the motor terminals.

Turn off the frequency converter and remove the short-circuit.

**WARNING/ALARM 17****Control word timeout:**

There is no communication to the frequency converter.

The warning will only be active when par. 8-04 is NOT set to *OFF*.

If par. 8-04 is set to *Stop* and *Trip*, a warning appears and the frequency converter ramps down until it trips, while giving an alarm.

par. 8-03 *Control word Timeout Time* could possibly be increased.

**WARNING 25****Brake resistor short-circuited:**

The brake resistor is monitored during operation. If it short-circuits, the brake function is disconnected and the warning appears. The frequency converter still works, but without the brake function. Turn off the frequency converter and replace the brake resistor (see par. 2-15 *Brake Check*).

**ALARM/WARNING 26****Brake resistor power limit:**

The power transmitted to the brake resistor is calculated as a percentage, as a mean value over the last 120 s, on the basis of the resistance value of the brake resistor (par. 2-11) and the intermediate circuit voltage. The warning is active when the dissipated braking power is higher than 90%. If *Trip* [2] has been selected in par. 2-13, the frequency converter cuts out and issues this alarm, when the dissipated braking power is higher than 100%.

**WARNING 27****Brake chopper fault:**

The brake transistor is monitored during operation and if it short-circuits, the brake function disconnects and the warning comes up. The frequency converter is still able to run, but since the brake transistor has short-circuited, substantial power is transmitted to the brake resistor, even if it is inactive.

Turn off the frequency converter and remove the brake resistor.



Warning: There is a risk of substantial power being transmitted to the brake resistor if the brake transistor is short-circuited.

**ALARM/WARNING 28****Brake check failed:**

Brake resistor fault: the brake resistor is not connected/working.

**ALARM 29****Frequency converter over temperature:**

If the enclosure is IP 20 or IP 21/TYPE 1, the cut-out temperature of the heat-sink is 95 °C ±5 °C, dependent on size of frequency converter. The temperature fault cannot be reset, until the temperature of the heatsink is below 70 °C ±5 °C.

The fault could be:

- Ambient temperature too high
- Too long motor cable

**ALARM 30****Motor phase U missing:**

Motor phase U between the frequency converter and the the motor is missing.

Turn off the frequency converter and check motor phase U.

**ALARM 31****Motor phase V missing:**

Motor phase V between the frequency converter and the motor is missing.

Turn off the frequency converter and check motor phase V.

**ALARM 32****Motor phase W missing:**

Motor phase W between the frequency converter and the motor is missing.

Turn off the frequency converter and check motor phase W.

**ALARM 33****Inrush fault:**

Too many power-ups have occurred within a short time period. See the chapter *Specifications* for the allowed number of powerups within one minute.

**WARNING/ALARM 34****Fieldbus communication fault:**

The fieldbus on the communication option card is not working.

**WARNING 35****Out of frequency range:**

This warning is active if the output frequency has reached its *Warning speed low* (par. 4-52) or *Warning speed high* (par. 4-53). If the frequency converter is in *Process control, closed loop* (par. 1-00), the warning is active in the display. If the frequency converter is not in this mode bit 008000 Out of *frequency range* in extended status word is active but there is no warning in the display.

**ALARM 38****Internal fault:**

Contact the local Danfoss supplier.

**WARNING 47****24 V supply low:**

The external 24 V DC backup power supply may be overloaded, otherwise contact the local Danfoss supplier.

**WARNING 48****1.8 V supply low:**

Contact the local Danfoss supplier.

**ALARM 50****AMA calibration failed:**

Contact the local Danfoss supplier.

**ALARM 51****AMA check Unom and Inom:**

The setting of motor voltage, motor current, and motor power is presumably wrong. Check the settings.

**ALARM 52****AMA low Inom:**

The motor current is too low. Check the settings.

**ALARM 53****AMA motor too big:**

The motor is too big for the AMA to be carried out.

**ALARM 54****AMA motor too small:**

The motor is too small for the AMA to be carried out.

**ALARM 55****AMA par. out of range:**

The par. values found from the motor are outside acceptable range.

**ALARM 56****AMA interrupted by user:**

The AMA has been interrupted by the user.

**ALARM 57****AMA timeout:**

Try to start the AMA again a number of times, until the AMA is carried out. Please note that repeated runs may heat the motor to a level where the resistance  $R_s$  and  $R_r$  are increased. In most cases, however, this is not critical.

**ALARM 58****AMA internal fault:**

Contact the local Danfoss supplier.

**WARNING 59****Current limit:**

Contact the local Danfoss supplier.

**WARNING 62****Output Frequency at Maximum Limit:**

The output frequency is higher than the value set in par. 4-19

**WARNING 64****Voltage Limit:**

The load and speed combination demands a motor voltage higher than the actual DC link voltage.

**WARNING/ALARM/TRIP 65****Control Card Over Temperature:**

Control card over temperature: The cut-out temperature of the control card is 80° C.

**WARNING 66****Heatsink Temperature Low:**

The heat sink temperature is measured as 0° C. This could indicate that the temperature sensor is defective and thus the fan speed is increased to the maximum in case the power part or control card is very hot.

**ALARM 67****Option Configuration has Changed:**

One or more options has either been added or removed since the last power-down.

**ALARM 68****Safe Stop Activated:**

Safe Stop has been activated. To resume normal operation, apply 24 V DC to terminal 37, then send a reset signal (via Bus, Digital I/O, or by pressing [RESET]). For correct and safe use of the Safe Stop function follow the related information and instructions in the Design Guide

**ALARM 70****Illegal Frequency Configuration:**

Actual combination of control board and power board is illegal.

**ALARM 80****Initialization to Default Value:**

Parameter settings are initialised to default setting after a manual (three-finger) reset.



# 8. Specifications

## 8.1. General Specifications

### 8.1.1. Mains Supply 3 x 200 - 240 VAC

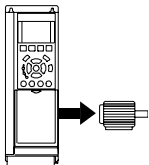
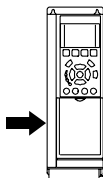
Normal overload 110% for 1 minute						
IP 20	A2	A2	A2	A3	A3	
IP 21	A2	A2	A2	A3	A3	
IP 55	A5	A5	A5	A5	A5	
IP 66	A5	A5	A5	A5	A5	
Mains supply 200 - 240 VAC						
Frequency converter	P1K1	P1K5	P2K2	P3K0	P3K7	
Typical Shaft Output [kW]	1.1	1.5	2.2	3	3.7	
Typical Shaft Output [HP] at 208 V						
Output current						
	Continuous (3 x 200-240 V) [A]	6.6	7.5	10.6	12.5	16.7
	Intermittent (3 x 200-240 V) [A]	7.3	8.3	11.7	13.8	18.4
	Continuous kVA (208 V AC) [kVA]	2.38	2.70	3.82	4.50	6.00
	Max. cable size: (mains, motor, brake) [mm <sup>2</sup> /AWG]	4/10				
	Max. input current					
	Continuous (3 x 200-240 V) [A]	5.9	6.8	9.5	11.3	15.0
	Intermittent (3 x 200-240 V) [A]	6.5	7.5	10.5	12.4	16.5
	Max. pre-fuses <sup>1)</sup> [A]	20	20	20	32	32
	Environment					
	Estimated power loss at rated max. load [W] <sup>4)</sup>	63	82	116	155	185
Weight enclosure IP20 [kg]	4.9	4.9	4.9	6.6	6.6	
Weight enclosure IP21 [kg]	5.5	5.5	5.5	7.5	7.5	
Weight enclosure IP55 [kg]	13.5	13.5	13.5	13.5	13.5	
Weight enclosure IP 66 [kg]	13.5	13.5	13.5	13.5	13.5	
Efficiency <sup>4)</sup>	0.96	0.96	0.96	0.96	0.96	

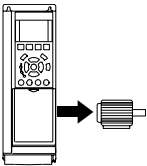
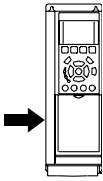
Normal overload 110% for 1 minute					
IP 20					
IP 21	B1	B1	B1	B2	
IP 55	B1	B1	B1	B2	
IP 66	B1	B1	B1	B2	
Mains supply 200 - 240 VAC					
Frequency converter	P5K5	P7K5	P11K	P15K	
Typical Shaft Output [kW]	5.5	7.5	11	15	
Typical Shaft Output [HP] at 208 V	7.5	10	15	20	
Output current					
	Continuous (3 x 200-240 V ) [A]	24.2	30.8	46.2	59.4
	Intermittent (3 x 200-240 V ) [A]	26.6	33.9	50.8	65.3
	Continuous kVA (208 V AC) [kVA]	8.7	11.1	16.6	21.4
	Max. cable size: (mains, motor, brake) [mm <sup>2</sup> /AWG]		10/7		35/2
	Max. input current				
	Continuous (3 x 200-240 V ) [A]	22.0	28.0	42.0	54.0
	Intermittent (3 x 200-240 V ) [A]	24.2	30.8	46.2	59.4
	Max. pre-fuses <sup>1)</sup> [A]	63	63	63	80
	Environment				
	Estimated power loss at rated max. load [W] <sup>4)</sup>	269	310	447	602
Weight enclosure IP20 [kg]					
Weight enclosure IP21 [kg]	23	23	23	27	
Weight enclosure IP55 [kg]	23	23	23	27	
Weight enclosure IP 66 [kg]	23	23	23	27	
Efficiency <sup>4)</sup>	0.96	0.96	0.96	0.96	

<b>Normal overload 110% for 1 minute</b>						
IP 20						
IP 21	C1	C1	C1	C2	C2	
IP 55	C1	C1	C1	C2	C2	
IP 66	C1	C1	C1	C2	C2	
<b>Mains supply 200 - 240 VAC</b>						
Frequency converter	P18K	P22K	P30K	P37K	P45K	
Typical Shaft Output [kW]	18.5	22	30	37	45	
Typical Shaft Output [HP] at 208 V	25	30	40	50	60	
<b>Output current</b>						
	Continuous (3 x 200-240 V ) [A]	74.8	88.0	115	143	170
	Intermittent (3 x 200-240 V ) [A]	82.3	96.8	127	157	187
	Continuous kVA (208 V AC) [kVA]	26.9	31.7	41.4	51.5	61.2
	Max. cable size: (mains, motor, brake) [mm <sup>2</sup> /AWG]	50/1/0		95/4/0		120/25 0 MCM
	<b>Max. input current</b>					
	Continuous (3 x 200-240 V ) [A]	68.0	80.0	104.0	130.0	154.0
	Intermittent (3 x 200-240 V ) [A]	74.8	88.0	114.0	143.0	169.0
	Max. pre-fuses <sup>1)</sup> [A]	125	125	160	200	250
	<b>Environment</b>					
	Estimated power loss at rated max. load [W] <sup>4)</sup>	737	845	1140	1353	1636
	Weight enclosure IP20 [kg]					
	Weight enclosure IP21 [kg]	45	45	65	65	65
Weight enclosure IP55 [kg]	45	45	65	65	65	
Weight enclosure IP 66 [kg]	45	45	65	65	65	
Efficiency <sup>4)</sup>	0.96	0.97	0.97	0.97	0.97	

### 8.1.2. Mains Supply 3 x 380 - 480 VAC

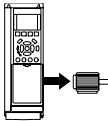
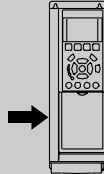
<b>Normal overload 110% for 1 minute</b>									
Frequency converter	P1K1	P1K5	P2K2	P3K0	P4K0	P5K5	P7K5		
Typical Shaft Output [kW]	1.1	1.5	2.2	3	4	5.5	7.5		
Typical Shaft Output [HP] at 460 V									
IP 20	A2	A2	A2	A2	A2	A3	A3		
IP 21									
IP 55	A5	A5	A5	A5	A5	A5	A5		
IP 66	A5	A5	A5	A5	A5	A5	A5		
<b>Output current</b>									
	Continuous (3 x 380-440 V) [A]	3	4.1	5.6	7.2	10	13	16	
	Intermittent (3 x 380-440 V) [A]	3.3	4.5	6.2	7.9	11	14.3	17.6	
	Continuous (3 x 440-480 V) [A]	2.7	3.4	4.8	6.3	8.2	11	14.5	
	Intermittent (3 x 440-480 V) [A]	3.0	3.7	5.3	6.9	9.0	12.1	15.4	
	Continuous kVA (400 V AC) [kVA]	2.1	2.8	3.9	5.0	6.9	9.0	11.0	
	Continuous kVA (460 V AC) [kVA]	2.4	2.7	3.8	5.0	6.5	8.8	11.6	
	Max. cable size: (mains, motor, brake) [[mm <sup>2</sup> / AWG]				4/ 10				
	<b>Max. input current</b>								
		Continuous (3 x 380-440 V) [A]	2.7	3.7	5.0	6.5	9.0	11.7	14.4
		Intermittent (3 x 380-440 V) [A]	3.0	4.1	5.5	7.2	9.9	12.9	15.8
Continuous (3 x 440-480 V) [A]		2.7	3.1	4.3	5.7	7.4	9.9	13.0	
Intermittent (3 x 440-480 V) [A]		3.0	3.4	4.7	6.3	8.1	10.9	14.3	
Max. pre-fuses <sup>1)</sup> [A]		10	10	20	20	20	32	32	
<b>Environment</b>									
Estimated power loss at rated max. load [W] <sup>4)</sup>		58	62	88	116	124	187	255	
Weight enclosure IP20 [kg]		4.8	4.9	4.9	4.9	4.9	6.6	6.6	
Weight enclosure IP 21 [kg]									
Weight enclosure IP 55 [kg]		13.5	13.5	13.5	13.5	13.5	14.2	14.2	
Weight enclosure IP 66 [kg]	13.5	13.5	13.5	13.5	13.5	14.2	14.2		
Efficiency <sup>4)</sup>	0.96	0.97	0.97	0.97	0.97	0.97	0.97		

<b>Normal overload 110% for 1 minute</b>										
Frequency converter	P11K	P15K	P18K	P22K	P30K	P37K	P45K	P55K	P75K	P90K
Typical Shaft Output [kW]	11	15	18.5	22	30	37	45	55	75	90
Typical Shaft Output [HP] at 460 V	15	20	25	30	40	50	60	75	100	125
IP 20										
IP 21	B1	B1	B1	B2	B2	C1	C1	C1	C2	C2
IP 55	B1	B1	B1	B2	B2	C1	C1	C1	C2	C2
IP 66	B1	B1	B1	B2	B2	C1	C1	C1		
<b>Output current</b>										
Continuous (3 x 380-440 V) [A]	24	32	37.5	44	61	73	90	106	147	177
Intermittent (3 x 380-440 V) [A]	26.4	35.2	41.3	48.4	67.1	80.3	99	117	162	195
Continuous (3 x 440-480 V) [A]	21	27	34	40	52	65	80	105	130	160
Intermittent (3 x 440-480 V) [A]	23.1	29.7	37.4	44	61.6	71.5	88	116	143	176
Continuous kVA (400 V AC) [kVA]	16.6	22.2	26	30.5	42.3	50.6	62.4	73.4	102	123
Continuous kVA (460 V AC) [kVA]	16.7	21.5	27.1	31.9	41.4	51.8	63.7	83.7	104	128
Max. cable size: (mains, motor, brake) [[mm <sup>2</sup> /AWG]		10/7		35/2		50/1/0			104	128
<b>Max. input current</b>										
Continuous (3 x 380-440 V) [A]	22	29	34	40	55	66	82	96	133	161
Intermittent (3 x 380-440 V) [A]	24.2	31.9	37.4	44	60.5	72.6	90.2	106	146	177
Continuous (3 x 440-480 V) [A]	19	25	31	36	47	59	73	95	118	145
Intermittent (3 x 440-480 V) [A]	20.9	27.5	34.1	39.6	51.7	64.9	80.3	105	130	160
Max. pre-fuses <sup>1)</sup> [A]	63	63	63	63	80	100	125	160	250	250
<b>Environment</b>										
Estimated power loss at rated max. load [W] <sup>4)</sup>	278	392	465	525	739	698	843	1083	1384	1474
Weight enclosure IP20 [kg]										
Weight enclosure IP 21 [kg]	23	23	23	27	27	45	45	45	65	65
Weight enclosure IP 55 [kg]	23	23	23	27	27	45	45	45	65	65
Weight enclosure IP 66 [kg]	23	23	23	27	27	45	45	45	-	-
Efficiency <sup>4)</sup>	0.98	0.98	0.98	0.98	0.98	0.98	0.98	0.98	0.98	0.99

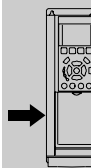
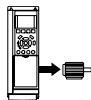

1. For type of fuse see section *Fuses*
2. American Wire Gauge
3. Measured using 5 m screened motor cables at rated load and rated frequency
4. The typical power loss is at normal load conditions and expected to be within +/- 15% (tolerance relates to variety in voltage and cable conditions).  
 Values are based on a typical motor efficiency (eff2/eff3 border line). Lower efficiency motors will also add to the power loss in the frequency converter and vice versa.  
 If the switching frequency is raised from nominal the power losses may rise significantly. LCP and typical control card power consumptions are included. Further options and customer load may add up to 30W to the losses. (Though typically only 4W extra for a fully loaded control card, or options for slot A or slot B, each).  
 Although measurements are made with state of the art equipment, some measurement inaccuracy must be allowed for (+/- 5%).

## Protection and Features:

- Electronic thermal motor protection against overload.
- Temperature monitoring of the heatsink ensures that the frequency converter trips if the temperature reaches  $95\text{ °C} \pm 5\text{ °C}$ . An overload temperature cannot be reset until the temperature of the heatsink is below  $70\text{ °C} \pm 5\text{ °C}$  (Guideline - these temperatures may vary for different power sizes, enclosures etc.). VLT HVAC Drive has an auto derating function to avoid it's heatsink reaching  $95\text{ deg C}$ .
- The frequency converter is protected against short-circuits on motor terminals U, V, W.
- If a mains phase is missing, the frequency converter trips or issues a warning (depending on the load).
- Monitoring of the intermediate circuit voltage ensures that the frequency converter trips if the intermediate circuit voltage is too low or too high.
- The frequency converter is protected against earth faults on motor terminals U, V, W.

## Mains supply (L1, L2, L3):

Supply voltage	200-240 V $\pm 10\%$
Supply voltage	380-480 V $\pm 10\%$
Supply voltage	525-600 V $\pm 10\%$
Supply frequency	50/60 Hz
Max. imbalance temporary between mains phases	3.0 % of rated supply voltage
True Power Factor ( $\lambda$ )	$\geq 0.9$ nominal at rated load
Displacement Power Factor ( $\cos\phi$ ) near unity	(> 0.98)
Switching on input supply L1, L2, L3 (power-ups) $\leq$ enclosure type A	maximum 2 times/min.
Switching on input supply L1, L2, L3 (power-ups) $\geq$ enclosure type B, C	maximum 1 time/min.
Environment according to EN60664-1	overvoltage category III/pollution degree 2

*The unit is suitable for use on a circuit capable of delivering not more than 100.000 RMS symmetrical Amperes, 240/480/600 V maximum.*

## Motor output (U, V, W):

Output voltage	0 - 100% of supply voltage
Output frequency	0 - 1000 Hz
Switching on output	Unlimited
Ramp times	1 - 3600 sec.

## Torque characteristics:

Starting torque (Constant torque)	maximum 110% for 1 min.*
Starting torque	maximum 135% up to 0.5 sec.*
Overload torque (Constant torque)	maximum 110% for 1 min.*

*\*Percentage relates to VLT HVAC Drive's nominal torque.*

## Cable lengths and cross sections:

Max. motor cable length, screened/armoured	VLT AQUA Drive: 150 m
Max. motor cable length, unscreened/unarmoured	VLT AQUA Drive: 300 m
Max. cross section to motor, mains, load sharing and brake *	
Maximum cross section to control terminals, rigid wire	1.5 mm <sup>2</sup> /16 AWG (2 x 0.75 mm <sup>2</sup> )
Maximum cross section to control terminals, flexible cable	1 mm <sup>2</sup> /18 AWG
Maximum cross section to control terminals, cable with enclosed core	0.5 mm <sup>2</sup> /20 AWG
Minimum cross section to control terminals	0.25 mm <sup>2</sup>

*\* See Mains Supply tables for more information!*

## Digital inputs:

Programmable digital inputs	4 (6)
Terminal number	18, 19, 27 <sup>1)</sup> , 29, 32, 33,
Logic	PNP or NPN
Voltage level	0 - 24 V DC
Voltage level, logic '0' PNP	< 5 V DC
Voltage level, logic '1' PNP	> 10 V DC
Voltage level, logic '0' NPN	> 19 V DC
Voltage level, logic '1' NPN	< 14 V DC
Maximum voltage on input	28 V DC
Input resistance, R <sub>i</sub>	approx. 4 kΩ

All digital inputs are galvanically isolated from the supply voltage (PELV) and other high-voltage terminals.

1) Terminals 27 and 29 can also be programmed as output.

Analog inputs:

Number of analog inputs	2
Terminal number	53, 54
Modes	Voltage or current
Mode select	Switch S201 and switch S202
Voltage mode	Switch S201/switch S202 = OFF (U)
Voltage level	: 0 to + 10 (scaleable)
Input resistance, R <sub>i</sub>	approx. 10 kΩ
Max. voltage	± 20 V
Current mode	Switch S201/switch S202 = ON (I)
Current level	0/4 to 20 mA (scaleable)
Input resistance, R <sub>i</sub>	approx. 200 Ω
Max. current	30 mA
Resolution for analog inputs	10 bit (+ sign)
Accuracy of analog inputs	Max. error 0.5% of full scale
Bandwidth	: 200 Hz

The analog inputs are galvanically isolated from the supply voltage (PELV) and other high-voltage terminals.

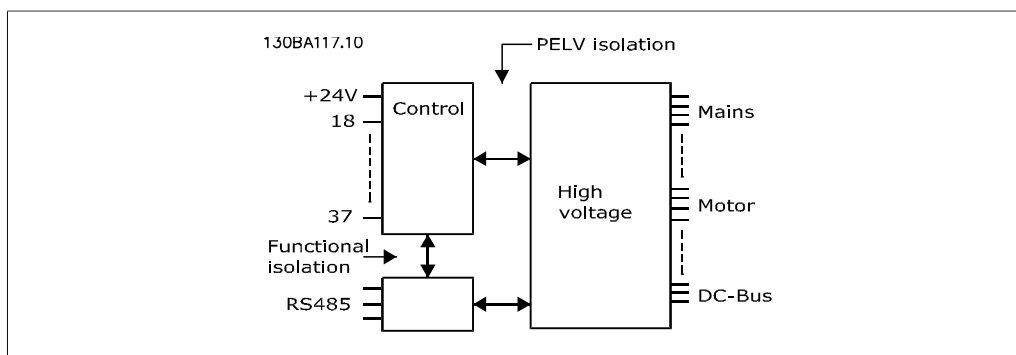

## Pulse inputs:

Programmable pulse inputs	2
Terminal number pulse	29, 33
Max. frequency at terminal, 29, 33	110 kHz (Push-pull driven)
Max. frequency at terminal, 29, 33	5 kHz (open collector)
Min. frequency at terminal 29, 33	4 Hz
Voltage level	see section on Digital input
Maximum voltage on input	28 V DC
Input resistance, $R_i$	approx. 4 k $\Omega$
Pulse input accuracy (0.1 - 1 kHz)	Max. error: 0.1% of full scale

## Analog output:

Number of programmable analog outputs	1
Terminal number	42
Current range at analog output	0/4 - 20 mA
Max. load to common at analog output	500 $\Omega$
Accuracy on analog output	Max. error: 0.5 % of full scale
Resolution on analog output	8 bit

*The analog output is galvanically isolated from the supply voltage (PELV) and other high-voltage terminals.*

## Control card, RS-485 serial communication:

Terminal number	68 (P,TX+, RX+), 69 (N,TX-, RX-)
Terminal number 61	Common for terminals 68 and 69

*The RS-485 serial communication circuit is functionally separated from other central circuits and galvanically isolated from the supply voltage (PELV).*

## Digital output:

Programmable digital/pulse outputs	2
Terminal number	27, 29 <sup>1)</sup>
Voltage level at digital/frequency output	0 - 24 V
Max. output current (sink or source)	40 mA
Max. load at frequency output	1 k $\Omega$
Max. capacitive load at frequency output	10 nF
Minimum output frequency at frequency output	0 Hz
Maximum output frequency at frequency output	32 kHz
Accuracy of frequency output	Max. error: 0.1 % of full scale
Resolution of frequency outputs	12 bit

*1) Terminal 27 and 29 can also be programmed as input.*

*The digital output is galvanically isolated from the supply voltage (PELV) and other high-voltage terminals.*

## Control card, 24 V DC output:

Terminal number	12, 13
Max. load	: 200 mA

*The 24 V DC supply is galvanically isolated from the supply voltage (PELV), but has the same potential as the analog and digital inputs and outputs.*



## Relay outputs:

Programmable relay outputs	2
<b>Relay 01 Terminal number</b>	1-3 (break), 1-2 (make)
Max. terminal load (AC-1) <sup>1)</sup> on 1-3 (NC), 1-2 (NO) (Resistive load)	240 V AC, 2 A
Max. terminal load (AC-15) <sup>1)</sup> (Inductive load @ cosφ 0.4)	240 V AC, 0.2 A
Max. terminal load (DC-1) <sup>1)</sup> on 1-2 (NO), 1-3 (NC) (Resistive load)	60 V DC, 1A
Max. terminal load (DC-13) <sup>1)</sup> (Inductive load)	24 V DC, 0.1A
<b>Relay 02 Terminal number</b>	4-6 (break), 4-5 (make)
Max. terminal load (AC-1) <sup>1)</sup> on 4-5 (NO) (Resistive load)	400 V AC, 2 A
Max. terminal load (AC-15) <sup>1)</sup> on 4-5 (NO) (Inductive load @ cosφ 0.4)	240 V AC, 0.2 A
Max. terminal load (DC-1) <sup>1)</sup> on 4-5 (NO) (Resistive load)	80 V DC, 2 A
Max. terminal load (DC-13) <sup>1)</sup> on 4-5 (NO) (Inductive load)	24 V DC, 0.1A
Max. terminal load (AC-1) <sup>1)</sup> on 4-6 (NC) (Resistive load)	240 V AC, 2 A
Max. terminal load (AC-15) <sup>1)</sup> on 4-6 (NC) (Inductive load @ cosφ 0.4)	240 V AC, 0.2A
Max. terminal load (DC-1) <sup>1)</sup> on 4-6 (NC) (Resistive load)	50 V DC, 2 A
Max. terminal load (DC-13) <sup>1)</sup> on 4-6 (NC) (Inductive load)	24 V DC, 0.1 A
Min. terminal load on 1-3 (NC), 1-2 (NO), 4-6 (NC), 4-5 (NO)	24 V DC 10 mA, 24 V AC 20 mA
Environment according to EN 60664-1	overvoltage category III/pollution degree 2

1) IEC 60947 part 4 and 5

The relay contacts are galvanically isolated from the rest of the circuit by reinforced isolation (PELV).

## Control card, 10 V DC output:

Terminal number	50
Output voltage	10.5 V ±0.5 V
Max. load	15 mA

The 10 V DC supply is galvanically isolated from the supply voltage (PELV) and other high-voltage terminals.

## Control characteristics:

Resolution of output frequency at 0 - 1000 Hz	: +/- 0.003 Hz
System response time (terminals 18, 19, 27, 29, 32, 33)	: ≤ 2 ms
Speed control range (open loop)	1:100 of synchronous speed
Speed accuracy (open loop)	30 - 4000 rpm: Maximum error of ±8 rpm

All control characteristics are based on a 4-pole asynchronous motor

## Surroundings:

Enclosure ≤ enclosure type A	IP 20, IP 55
Enclosure ≥ enclosure type A, B	IP 21, IP 55
Enclosure kit available ≤ enclosure type A	IP21/TYP E 1/IP 4X top
Vibration test	1.0 g
Max. relative humidity	5% - 95%(IEC 721-3-3; Class 3K3 (non-condensing) during operation
Aggressive environment (IEC 721-3-3), uncoated	class 3C2
Aggressive environment (IEC 721-3-3), coated	class 3C3
Test method according to IEC 60068-2-43 H2S (10 days)	
Ambient temperature	Max. 50 °C

*Derating for high ambient temperature, see section on special conditions*

Minimum ambient temperature during full-scale operation	0 °C
Minimum ambient temperature at reduced performance	- 10 °C
Temperature during storage/transport	-25 - +65/70 °C
Maximum altitude above sea level without derating	1000 m
Maximum altitude above sea level with derating	3000 m

*Derating for high altitude, see section on special conditions*

EMC standards, Emission	EN 61800-3, EN 61000-6-3/4, EN 55011, IEC 61800-3 EN 61800-3, EN 61000-6-1/2, EN 61000-4-2, EN 61000-4-3, EN 61000-4-4, EN 61000-4-5, EN
EMC standards, Immunity	61000-4-6

*See section on special conditions*

## Control card performance:

Scan interval	: 5 ms
---------------	--------

## Control card, USB serial communication:

USB standard	1.1 (Full speed)
USB plug	USB type B "device" plug



Connection to PC is carried out via a standard host/device USB cable.  
The USB connection is galvanically isolated from the supply voltage (PELV) and other high-voltage terminals.  
The USB connection is not galvanically isolated from protection earth. Use only isolated laptop/PC as connection to the USB connector on VLT HVAC Drive or an isolated USB cable/converter.

## 8.2. Special Conditions

### 8.2.1. Purpose of derating

Derating must be taken into account when using the frequency converter at low air pressure (heights), at low speeds, with long motor cables, cables with a large cross section or at high ambient temperature. The required action is described in this section.

### 8.2.2. Derating for Ambient Temperature

The average temperature ( $T_{AMB,AVG}$ ) measured over 24 hours must be at least 5 °C lower than the maximum allowed ambient temperature ( $T_{AMB,MAX}$ ).

If the frequency converter is operated at high ambient temperatures, the continuous output current should be decreased.

The derating depends on the switching pattern, which can be set to 60 PWM or SFAVM in parameter 14-00.

**A enclosures**

**60 PWM - Pulse Width Modulation**

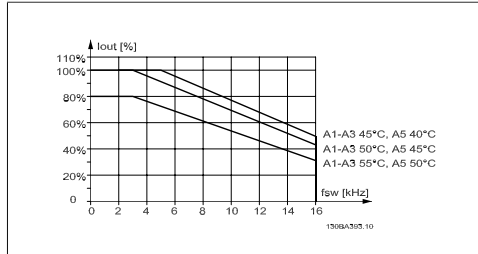

Illustration 8.1: Derating of  $I_{out}$  for different  $T_{AMB, MAX}$  for enclosure A, using 60 PWM

**SFAVM - Stator Frequency Asyncon Vector Modulation**

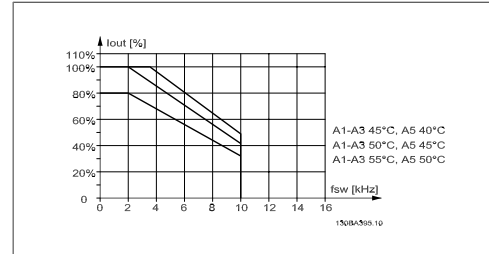

Illustration 8.2: Derating of  $I_{out}$  for different  $T_{AMB, MAX}$  for enclosure A, using SFAVM

In enclosure A, the length of the motor cable has a relatively high impact on the recommended derating. Therefore, the recommended derating for an application with max. 10 m motor cable is also shown.

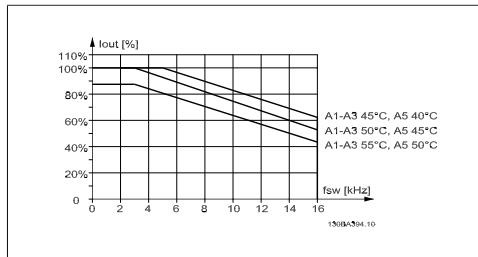

Illustration 8.3: Derating of  $I_{out}$  for different  $T_{AMB, MAX}$  for enclosure A, using 60 PWM and maximum 10 m motor cable

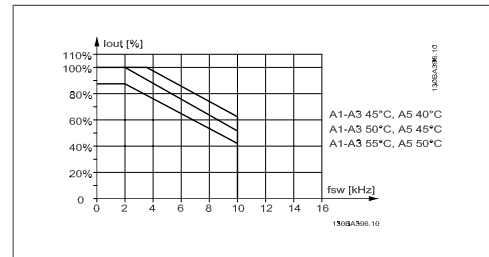

Illustration 8.4: Derating of  $I_{out}$  for different  $T_{AMB, MAX}$  for enclosure A, using SFAVM and maximum 10 m motor cable

**B enclosures**

**60 PWM - Pulse Width Modulation**

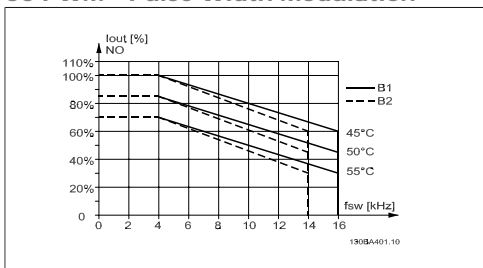

Illustration 8.5: Derating of  $I_{out}$  for different  $T_{AMB, MAX}$  for enclosure B, using 60 PWM in Normal torque mode (110% over torque)

**SFAVM - Stator Frequency Asyncon Vector Modulation**

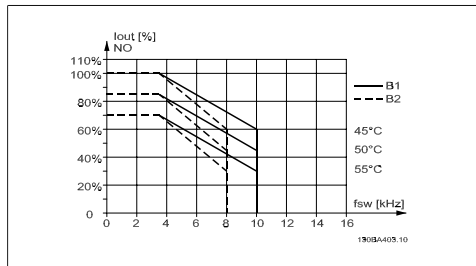

Illustration 8.6: Derating of  $I_{out}$  for different  $T_{AMB, MAX}$  for enclosure B, using SFAVM in Normal torque mode (110% over torque)

**C enclosures**

**60 PWM - Pulse Width Modulation**

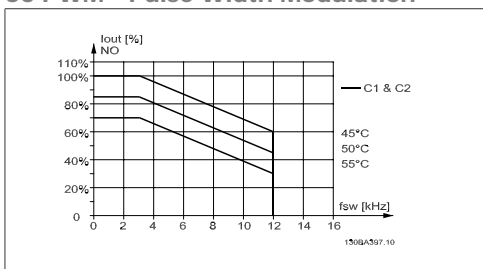

Illustration 8.7: Derating of  $I_{out}$  for different  $T_{AMB, MAX}$  for enclosure C, using 60 PWM in Normal torque mode (110% over torque)

**SFAVM - Stator Frequency Asyncon Vector Modulation**

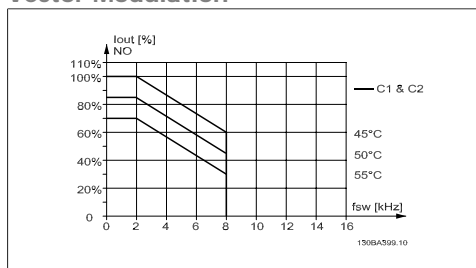

Illustration 8.8: Derating of  $I_{out}$  for different  $T_{AMB, MAX}$  for enclosure C, using SFAVM in Normal torque mode (110% over torque)

8

**8.2.3. Derating for Low Air Pressure**

The cooling capability of air is decreased at lower air pressure.

Below 1000 m altitude no derating is necessary but above 1000 m the ambient temperature ( $T_{AMB}$ ) or max. output current ( $I_{out}$ ) should be derated in accordance with the shown diagram.

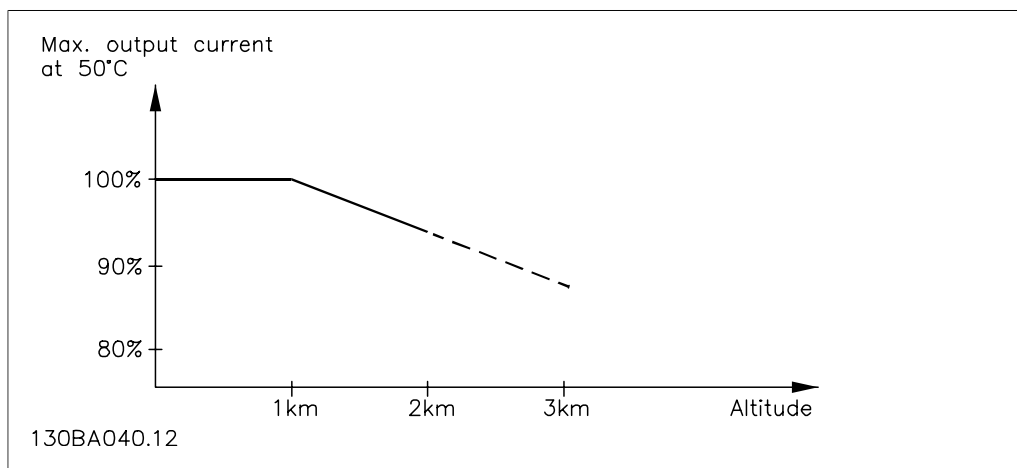

Illustration 8.9: Derating of output current versus altitude at  $T_{AMB, MAX}$ . By altitudes above 2 km, please contact Danfoss Drives regarding PELV.

An alternative is to lower the ambient temperature at high altitudes and thereby ensure 100% output current at high altitudes.

#### **8.2.4. Derating for Running at Low Speed**

When a motor is connected to a frequency converter, it is necessary to check that the cooling of the motor is adequate.

A problem may occur at low RPM values in constant torque applications. The motor fan may not be able to supply the required volume of air for cooling and this limits the torque that can be supported. Therefore, if the motor is to be run continuously at an RPM value lower than half of the rated value, the motor must be supplied with additional air-cooling (or a motor designed for this type of operation may be used).

An alternative is to reduce the load level of the motor by choosing a larger motor. However, the design of the frequency converter puts a limit to the motor size.

#### **8.2.5. Derating for Installing Long Motor Cables or Cables with Larger Cross-Section**

The maximum cable length for this frequency converter is 300 m unscreened and 150 m screened cable.

The frequency converter has been designed to work using a motor cable with a rated cross-section. If a cable with a larger cross-section is used, reduce the output current by 5% for every step the cross-section is increased.

(Increased cable cross-section leads to increased capacity to earth, and thus an increased earth leakage current).

#### **8.2.6. Automatic adaptations to ensure performance**

The frequency converter constantly checks for critical levels of internal temperature, load current, high voltage on the intermediate circuit and low motor speeds. As a response to a critical level, the frequency converter can adjust the switching frequency and/ or change the switching pattern in order to ensure the performance of the drive. The capability to automatically reduce the output current extends the acceptable operating conditions even further.

## Index

### A

Abbreviations And Standards	12
Acceleration Time	58
Access To Control Terminals	33
Ama	52
Analog Inputs	135
Analog Output	136
Auto Energy Optimization Compressor	66
Auto Energy Optimization Vt	67
Automatic Adaptations To Ensure Performance	141
Automatic Motor Adaptation (ama)	39, 67

### B

Baud Rate	53, 86
Brake And Over-voltage Functions, 2-10	70
Branch Circuit Protection	21
Broken Belt Delay, 22-62	82
Broken Belt Function, 22-60	82
Broken Belt Torque, 22-61	82

### C

Cable Lengths And Cross Sections	134
Changing A Group Of Numeric Data Values	85
Changing A Text Value	84
Changing Data	84
Changing Of Data Value	85
Checklist	13
Clockwise	72
Coasting	46
Communication Option	126
Configuration Mode, 1-00	66
Control Cables	37
Control Cables	37
Control Card Performance	138
Control Card, +10 V Dc Output	137
Control Card, 24 V Dc Output	136
Control Card, Rs-485 Serial Communication	136
Control Card, Usb Serial Communication	138
Control Characteristics	137
Control Terminals	34
Cooling	68, 141
Correct Mounting Of Screws	16

### D

Dc Hold Current/preheat Current, 2-00	70
Dc Hold/preheat	68
Dc Link	123
Default Settings	53, 86
Derating For Ambient Temperature	138
Derating For Installing Long Motor Cables Or Cables With Larger Cross-section	141
Derating For Low Air Pressure	140
Derating For Running At Low Speed	141
Digital Inputs:	134
Digital Output	136
Display Line 1.2 Small, 0-21	64
Display Line 1.3 Small, 0-22	64
Display Line 2 Large, 0-23	64
Display Line 3 Large, 0-24	65
Disposal Instruction	8
Drilling Of Holes	16
Dry Pump Function, 22-26	81

Dst/summertime Start, 0-76	66
<b>E</b>	
Earth Leakage Current	3
Efficient Parameter Set-up For Hvac Applications	56
Electrical Installation	37
Electrical Terminals	37
Electronic Thermal Relay	69
Etr	68, 124
<b>F</b>	
Feedback 1 Conversion, 20-01	78
Feedback 1 Source, 20-00	78
Feedback 2 Conversion, 20-04	78
Feedback 2 Source, 20-03	78
Feedback 3 Conversion, 20-07	78
Feedback 3 Source, 20-06	78
Feedback Function, 20-20	79
Flying Start	67
Frequency Converter	38
Function At Stop, 1-80	68
Function Relay, 5-40	73
Function Setups	59
Fuses	21
<b>G</b>	
General Warning.	3, 11
Glcp	52
Graphical Display	41
<b>H</b>	
How To Connect A Pc To The Fc 100	50
How To Operate Graphical Lcp (glcp)	41
<b>I</b>	
Indexed Parameters	85
Indicator Lights	44
Initialisation	53, 86
Installation At High Altitudes (pelv)	6
Intermediate Circuit	123
Interval Between Starts, 22-76	82
<b>J</b>	
Jog Speed	59
<b>K</b>	
Kty Sensor	124
<b>L</b>	
Language	57
Lcp	47, 52
Lcp 102	41
Leakage Current	4
Leds	41
Live Zero Timeout Function, 6-01	74
Live Zero Timeout Time, 6-00	74
Low Power Detection, 22-21	81
Low Speed Detection, 22-22	81

## M

Main Menu	56
Main Menu Mode	45
Main Menu Mode	83
Main Menu Structure	88
Main Reactance	67
Mains Supply	129
Mains Supply (L1, L2, L3)	134
Manual Initialisation	86
Maximum Reference	71
Mct 10	51
Mechanical Dimensions	18, 20
Minimum Run Time, 22-40	82
Minimum Run Time, 22-77	83
Minimum Sleep Time, 22-41	82
Motor Current	58
Motor Frequency, 1-23	57
Motor Name Plate	38
Motor Nominal Speed, 1-25	58
Motor Output	134
Motor Overload Protection	3
Motor Power [hp]	57
Motor Power [hp], 1-21	57
Motor Power Parameter [kw], 1-20	57
Motor Protection	68, 134
Motor Speed Direction 4-10	72
Motor Speed High Limit [hz], 4-14	59
Motor Speed High Limit [rpm], 4-13	59
Motor Speed Low Limit Rpm, 4-11	58
Motor Thermal Protection, 1-90	68
Motor Voltage	57
Motor Voltage, 1-22	57
Mounting	14
Mounting A2 And A3	16
Mounting Of Unit	17

## N

Name Plate Data	39
Name Plate Data	38
Nlcp	47
No-flow Delay, 22-24	81
No-flow Function, 22-23	81
Non UI Compliance	22

## O

Output Performance (u, V, W)	134
Over-current Protection	21
Over-voltage Control, 2-17	70

## P

Parameter Selection	84
Parameter Set-up	55
Pc Software Tools	50
Pelv	6
Pid Integral Time, 20-94	81
Pid Normal/inverse Control, 20-81	86
Pid Proportional Gain, 20-93	81
Preset Reference	71
Profibus Dp-v1	51
Protection And Features	134
Pulse Inputs	136



## Q

Quick Menu	44, 56
Quick Menu Mode	45
Quick Menu Mode	56
Quick Transfer Of Parameter Settings When Using Glcp	52

## R

Ramp 1 Ramp-down Time, 3-42	58
Ramp-up Time 1 Parameter, 3-41	58
Reference 1 Source	71
Relay Outputs	137
Reset	47
Residual Current Device	4

## S

Screened/armoured.	37
Semi-auto By-pass Feature, 4-64	72
Serial Communication	138
Set Date And Time, 0-70	65
Setpoint 1, 20-21	80
Setpoint 2, 20-22	80
Short Circuit Protection	21
Short Cycle Protection, 22-75	82
Sine-wave Filter	30
Start Delay	67
Stator Leakage Reactance	67
Status	44
Status Messages	41
Step-by-step	85
Surroundings	138
Switches S201, S202, And S801	38
Switching Frequency, 14-01	77

## T

Terminal 27 Digital Input, 5-12	72
Terminal 29 Digital Input, 5-13	72
Terminal 29 Mode, 5-02	72
Terminal 32 Digital Input, 5-14	73
Terminal 33 Digital Input, 5-15	73
Terminal 42 Output, 6-50	76
Terminal 53 High Voltage, 6-11	74
Terminal 53 Low Voltage, 6-10	74
Thermistor	68
Thermistor Source, 1-93	69
Tightening Of Screws	17
Torque Characteristics	134
Torque Characteristics, 1-03	66
Type Code String	10
Type Code String (t/c).	9

## U

Usb Connection.	34
-----------------	----

## V

Variable Torque	66
Voltage Level	135

## W

Wake-up Speed [rpm], 22-42	82
Warning Feedback Low, 4-56	87