

Safety

WARNING

HIGH VOLTAGE!

Frequency converters contain high voltage when connected to AC mains input power. Installation, start up, and maintenance should be performed by qualified personnel only. Failure to perform installation, start up, and maintenance by qualified personnel could result in death or serious injury.

High Voltage

Frequency converters are connected to hazardous mains voltages. Extreme care should be taken to protect against shock. Only trained personnel familiar with electronic equipment should install, start, or maintain this equipment.

WARNING

UNINTENDED START!

When the frequency converter is connected to AC mains, the motor may start at any time. The frequency converter, motor, and any driven equipment must be in operational readiness. Failure to be in operational readiness when the frequency converter is connected to AC mains could result in death, serious injury, equipment, or property damage.

Unintended Start

When the frequency converter is connected to the AC mains, the motor may be started by means of an external switch, a serial bus command, an input reference signal, or a cleared fault condition. Use appropriate cautions to guard against an unintended start.

WARNING

DISCHARGE TIME!

Frequency converters contain DC link capacitors that can remain charged even when AC mains is disconnected. To avoid electrical hazards, remove AC mains from the frequency converter before doing any service or repair and wait the amount of time specified in *Table 1.1*. Failure to wait the specified time after power has been removed prior to doing service or repair on the unit could result in death or serious injury.

Voltage (V)	Minimum Waiting Time (Minutes)	
	4	15
200 - 240	1.1 - 3.7 kW 1 1/2 - 5 hp	5.5 - 45 kW 7 1/2 - 60 hp
380 - 480	1.1 - 7.5 kW 1 1/2 - 10 hp	11 - 90 kW 15 - 120 hp
525 - 600	1.1 - 7.5 kW 1 1/2 - 10 hp	11 - 90 kW 15 - 120 hp
525 - 690	n/a	11 - 90 kW 15 - 120 hp

High voltage may be present even when the warning LEDs are off!

Table 1.1 Discharge Time

Symbols

The following symbols are used in this manual.

WARNING

Indicates a potentially hazardous situation which, if not avoided, could result in death or serious injury.

CAUTION

Indicates a potentially hazardous situation which, if not avoided, may result in minor or moderate injury. It may also be used to alert against unsafe practices.

CAUTION

Indicates a situation that may result in equipment or property-damage-only accidents.

NOTE

Indicates highlighted information that should be regarded with attention to avoid mistakes or operate equipment at less than optimal performance.

Approvals



Contents

1 Introduction	4
1.1 Purpose of the Manual	5
1.2 Additional Resources	5
1.3 Product Overview	6
1.4 Internal Frequency Converter Controller Functions	6
1.5 Frame Sizes and Power Ratings	7
2 Installation	8
2.1 Installation Site Check List	8
2.2 Frequency Converter and Motor Pre-installation Check List	8
2.3 Mechanical Installation	8
2.3.1 Cooling	8
2.3.2 Lifting	9
2.3.3 Mounting	9
2.3.4 Tightening Torques	9
2.4 Electrical Installation	10
2.4.1 Requirements	12
2.4.2 Earth (Grounding) Requirements	13
2.4.2.1 Leakage Current (>3,5 mA)	13
2.4.2.2 Grounding Using Shielded Cable	13
2.4.2.3 Grounding Using Conduit	13
2.4.3 Motor Connection	14
2.4.4 AC Mains Connection	15
2.4.5 Control Wiring	15
2.4.5.1 Access	15
2.4.5.2 Control Terminal Types	16
2.4.5.3 Wiring to Control Terminals	17
2.4.5.4 Using Screened Control Cables	18
2.4.5.5 Control Terminal Functions	18
2.4.5.6 Jumper Terminals 12 and 27	18
2.4.5.7 Terminal 53 and 54 Switches	18
2.4.5.8 Terminal 37	19
2.4.6 Serial Communication	22
3 Start Up and Functional Testing	23
3.1 Pre-start	23
3.1.1 Safety Inspection	23
3.1.2 Start Up Check List	24
3.2 Applying Power to the Frequency Converter	25
3.3 Basic Operational Programming	25

3.4 Automatic Motor Adaptation	26
3.5 Check Motor Rotation	27
3.6 Local-control Test	27
3.7 System Start Up	28
4 User Interface	29
4.1 Local Control Panel	29
4.1.1 LCP Layout	29
4.1.2 Setting LCP Display Values	30
4.1.3 Display Menu Keys	30
4.1.4 Navigation Keys	31
4.1.5 Operation Keys	31
4.2 Back Up and Copying Parameter Settings	31
4.2.1 Uploading Data to the LCP	32
4.2.2 Downloading Data from the LCP	32
4.3 Restoring Default Settings	32
4.3.1 Recommended Initialisation	32
4.3.2 Manual Initialisation	32
5 About Frequency Converter Programming	33
5.1 Introduction	33
5.2 Programming Example	33
5.3 Control Terminal Programming Examples	34
5.4 International/North American Default Parameter Settings	35
5.5 Parameter Menu Structure	36
5.5.1 Quick Menu Structure	37
5.5.2 Main Menu Structure	39
5.6 Remote Programming with MCT-10	47
6 Application Set-Up Examples	48
6.1 Introduction	48
6.2 Application Examples	48
7 Status Messages	52
7.1 Status Display	52
7.2 Status Message Definitions Table	52
8 Warnings and Alarms	55
8.1 System Monitoring	55
8.2 Warning and Alarm Types	55
8.3 Warning and Alarm Displays	55
8.4 Warning and Alarm Definitions	56

8.4.1 Fault Messages	57
9 Basic Troubleshooting	64
9.1 Start Up and Operation	64
10 Specifications	66
10.1 Power-dependent Specifications	66
10.2 General Technical Data	71
10.3 Fuse Tables	76
10.3.1 Branch Circuit Protection Fuses	76
10.3.2 UL and cUL Branch Circuit Protection Fuses	77
10.3.3 Substitute Fuses for 240 V	78
10.4 Connection Tightening Torques	78
Index	79

1 Introduction

1

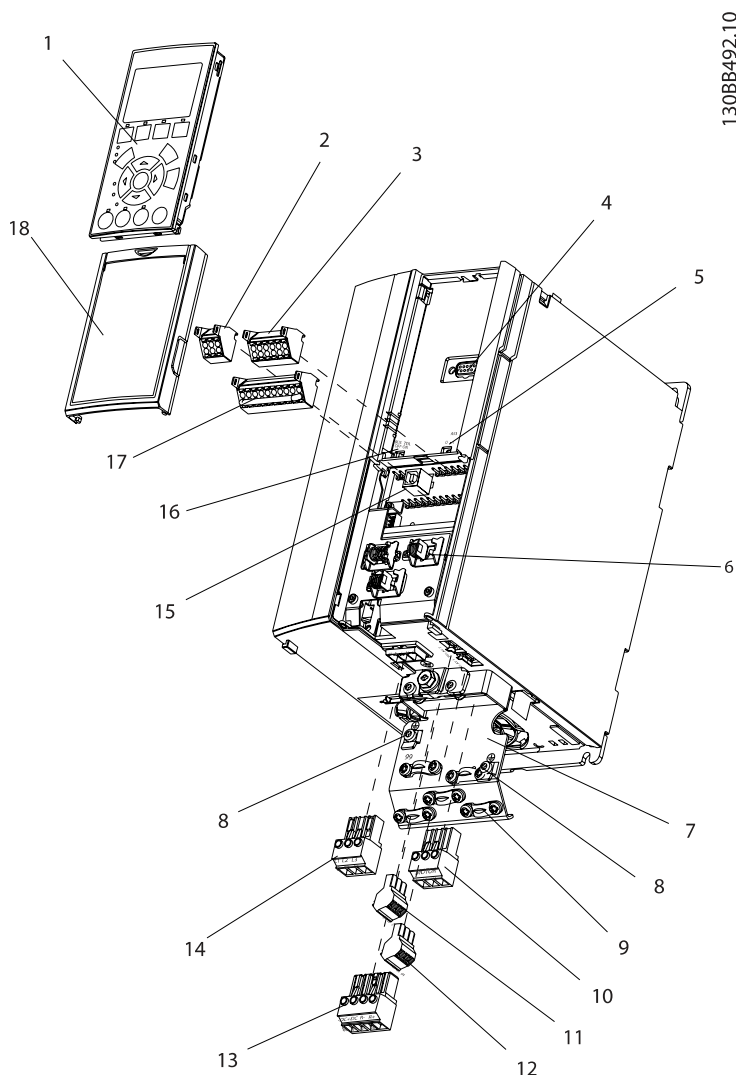

130BB492.10

Illustration 1.1 Exploded View A Size

1	LCP	10	Motor output terminals 96 (U), 97 (V), 98 (W)
2	RS-485 serial bus connector (+68, -69)	11	Relay 1 (01, 02, 03)
3	Analog I/O connector	12	Relay 2 (04, 05, 06)
4	LCP input plug	13	Brake (-81, +82) and load sharing (-88, +89) terminals
5	Analog switches (A53), (A54)	14	Mains input terminals 91 (L1), 92 (L2), 93 (L3)
6	Cable strain relief / PE ground	15	USB connector
7	Decoupling plate	16	Serial bus terminal switch
8	Grounding clamp (PE)	17	Digital I/O and 24 V power supply
9	Shielded cable grounding clamp and strain relief	18	Control cable cover plate

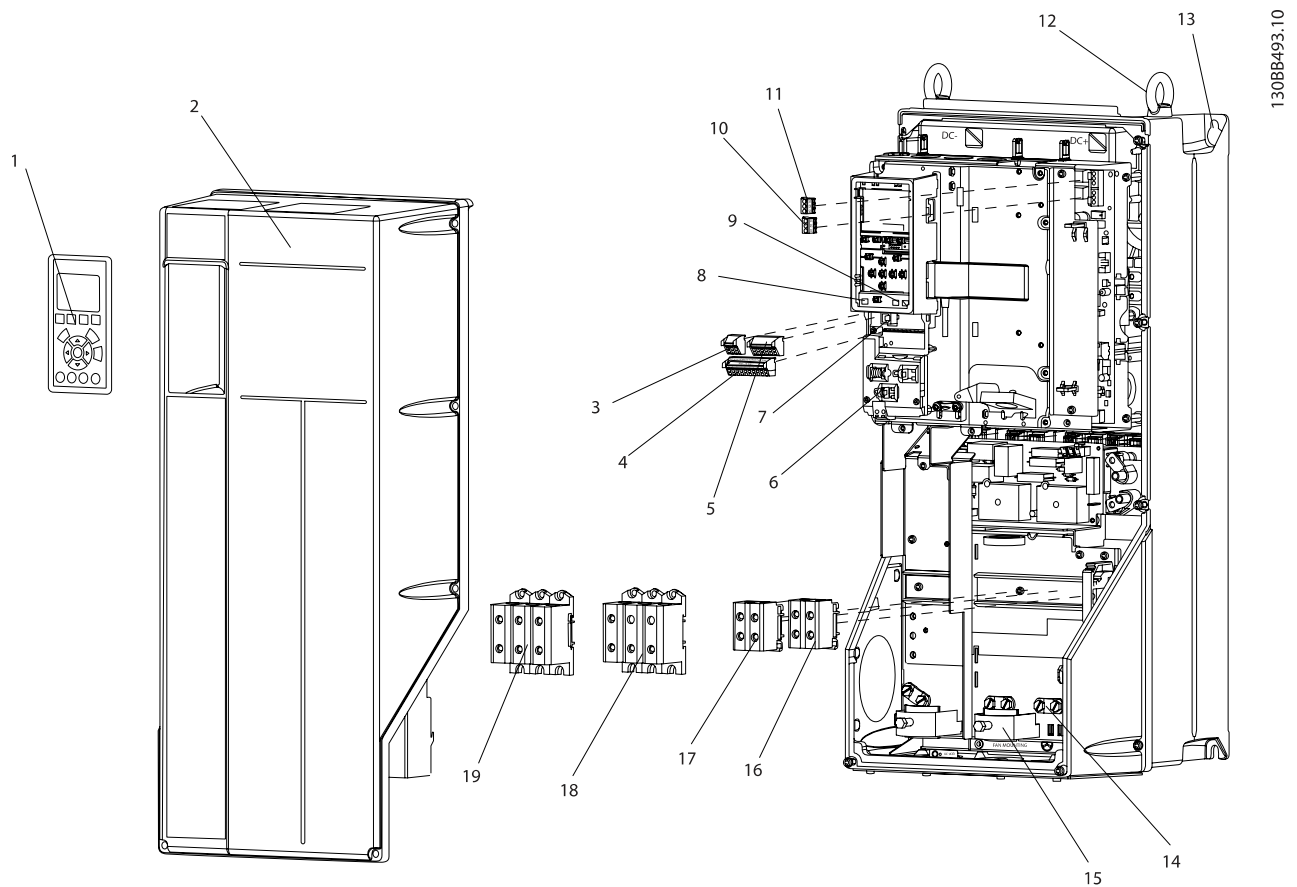

Illustration 1.2 Exploded View B and C Sizes

1	LCP	11	Relay 2 (04, 05, 06)
2	Cover	12	Lifting ring
3	RS-485 serial bus connector	13	Mounting slot
4	Digital I/O and 24 V power supply	14	Grounding clamp (PE)
5	Analog I/O connector	15	Cable strain relief / PE ground
6	Cable strain relief / PE ground	16	Brake terminal (-81, +82)
7	USB connector	17	Load sharing terminal (DC bus) (-88, +89)
8	Serial bus terminal switch	18	Motor output terminals 96 (U), 97 (V), 98 (W)
9	Analog switches (A53), (A54)	19	Mains input terminals 91 (L1), 92 (L2), 93 (L3)
10	Relay 1 (01, 02, 03)		

1.1 Purpose of the Manual

This manual is intended to provide detailed information for the installation and start up of the frequency converter. Chapter 2 *Installation* provides requirements for mechanical and electrical installation, including input, motor, control and serial communications wiring, and control terminal functions. Chapter 3 *Start Up and Functional Testing* provides detailed procedures for start up, basic operational programming, and functional testing. The remaining chapters provide supplementary details. These include user interface, detailed programming, application examples, start-up troubleshooting, and specifications.

1.2 Additional Resources

Other resources are available to understand advanced frequency controller functions and programming.

- The Programming Guide provides greater detail in how to work with parameters and many application examples.
- The Design Guide is intended to provide detailed capabilities and functionality to design motor control systems.

- Supplemental publications and manuals are available from Danfoss. See <http://www.danfoss.com/Products/Literature/Technical+Documentation.htm> for listings.
- Optional equipment is available that may change some of the procedures described. Be sure to see the instructions supplied with those options for specific requirements.

Contact your Danfoss supplier or go to <http://www.danfoss.com/Products/Literature/Technical+Documentation.htm> for downloads or additional information.

1.3 Product Overview

A frequency converter is an electronic motor controller that converts AC mains input into a variable AC waveform output. The frequency and voltage of the output are regulated to control the motor speed or torque. The frequency converter can vary the speed of the motor in response to system feedback, such as changing temperature or pressure for controlling fan, compressor, or pump motors. The frequency converter can also regulate the motor by responding to remote commands from external controllers.

In addition, the frequency converter monitors the system and motor status, issues warnings or alarms for fault conditions, starts and stops the motor, optimizes energy efficiency, and offers many more control, monitoring, and efficiency functions. Operation and monitoring functions are available as status indications to an outside control system or serial communication network.

1.4 Internal Frequency Converter Controller Functions

Below is a block diagram of the frequency converter's internal components. See *Table 1.1* for their functions.

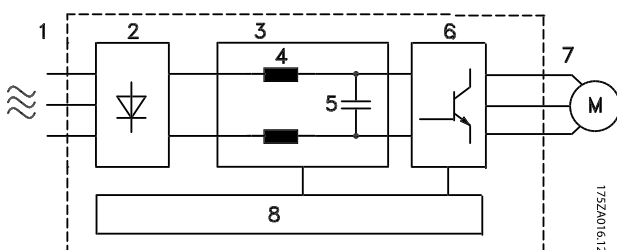

Illustration 1.3 Frequency Converter Block Diagram

Area	Title	Functions
1	Mains input	<ul style="list-style-type: none"> • Three-phase AC mains power supply to the frequency converter
2	Rectifier	<ul style="list-style-type: none"> • The rectifier bridge converts the AC input to DC current to supply inverter power
3	DC bus	<ul style="list-style-type: none"> • The frequency converter's intermediate DC-bus circuit handles the DC current
4	DC reactors	<ul style="list-style-type: none"> • Filter the intermediate DC circuit voltage • Provide line transient protection • Reduce RMS current • Raise the power factor reflected back to the line • Reduce harmonics on the AC input
5	Capacitor bank	<ul style="list-style-type: none"> • Stores the DC power • Provides ride-through protection for short power losses
6	Inverter	<ul style="list-style-type: none"> • Converts the DC into a controlled PWM AC waveform for a controlled variable output to the motor
7	Output to motor	<ul style="list-style-type: none"> • Regulated three-phase output power to the motor
8	Control circuitry	<ul style="list-style-type: none"> • Input power, internal processing, output, and motor current are monitored to provide efficient operation and control • User interface and external commands are monitored and performed • Status output and control can be provided

Table 1.1 Frequency Converter Internal Components

1.5 Frame Sizes and Power Ratings

References to frames sizes used in this manual are defined in *Table 1.2*.

Volts	Frame Size (kW)											
	A2	A3	A4	A5	B1	B2	B3	B4	C1	C2	C3	C4
200-240	1.1-2.2	3.0-3.7	0.25-2.2	1.1-3.7	5.5-11	15	5.5-11	15-18.5	18.5-30	37-45	22-30	37-45
380-480	1.1-4.0	5.5-7.5	0.37-4.0	1.1-7.5	11-18.5	22-30	11-18.5	22-37	37-55	75-90	45-55	75-90
525-600	n/a	1.1-7.5	n/a	1.1-7.5	11-18.5	22-30	11-18.5	22-37	37-55	75-90	45-55	75-90

Table 1.2 Frames Sizes and Power Ratings

2 Installation

2

2.1 Installation Site Check List

- The frequency converter relies on the ambient air for cooling. Observe the limitations on ambient air temperature for optimal operation
- Ensure that the installation location has sufficient support strength to mount the frequency converter
- Keep the frequency converter interior free from dust and dirt. Ensure that the components stay as clean as possible. In construction areas, provide a protective covering. Optional IP55 (NEMA 12) or IP66 (NEMA 4) enclosures may be necessary.
- Keep the manual, drawings, and diagrams accessible for detailed installation and operation instructions. It is important that the manual is available for equipment operators.
- Locate equipment as near to the motor as possible. Keep motor cables as short as possible. Check the motor characteristics for actual tolerances. Do not exceed
 - 300m (1000ft) for unshielded motor leads
 - 150m (500ft) for shielded cable.

2.2 Frequency Converter and Motor Pre-installation Check List

- Compare the model number of unit on the nameplate to what was ordered to verify the proper equipment
- Ensure each of the following are rated for same voltage:
 - Mains (power)
 - Frequency converter
 - Motor
- Ensure that frequency converter output current rating is equal to or greater than motor full load current for peak motor performance
 - Motor size and frequency converter power must match for proper overload protection
 - If frequency converter rating is less than motor, full motor output cannot be achieved

2.3 Mechanical Installation

2.3.1 Cooling

- To provide cooling airflow, mount the unit to a solid flat surface or to the optional back plate (see 2.3.3 Mounting)
- Top and bottom clearance for air cooling must be provided. Generally, 100-225mm (4-10in) is required. See *Illustration 2.1* for clearance requirements
- Improper mounting can result in over heating and reduced performance
- Derating for temperatures starting between 40°C (104°F) and 50°C (122°F) and elevation 1000m (3300ft) above sea level must be considered. See the equipment Design Guide for detailed information.

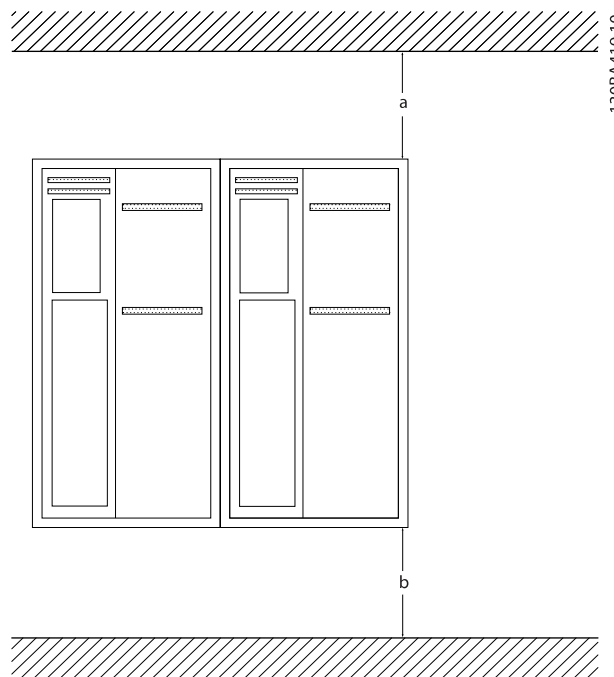

Illustration 2.1 Top and Bottom Cooling Clearance

Enclosure	A2	A3	A4	A5	B1	B2
a/b (mm)	100	100	100	100	200	200
a/b (in)	4	4	4	4	8	8
Enclosure	B3	B4	C1	C2	C3	C4
a/b (mm)	200	200	200	225	200	225
a/b (in)	8	8	8	9	8	9

Table 2.1 Minimum airflow clearance requirements

2.3.2 Lifting

- Check the weight of the unit to determine a safe lifting method
- Ensure that the lifting device is suitable for the task
- If necessary, plan for a hoist, crane, or forklift with the appropriate rating to move the unit
- For lifting, use hoist rings on the unit, when provided

2.3.3 Mounting

- Mount the unit vertically
- The frequency converter allows side by side installation
- Ensure that the strength of the mounting location will support the unit weight
- Mount the unit to a solid flat surface or to the optional back plate to provide cooling airflow (see *Illustration 2.2* and *Illustration 2.3*)
- Improper mounting can result in over heating and reduced performance
- Use the slotted mounting holes on the unit for wall mounting, when provided

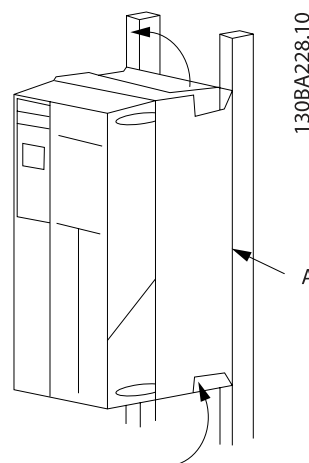

Illustration 2.3 Proper mounting with railings

NOTE

Back plate is needed when mounted on railings.

2.3.4 Tightening Torques

See *10.4.1 Connection Tightening Torques* for proper tightening specifications.

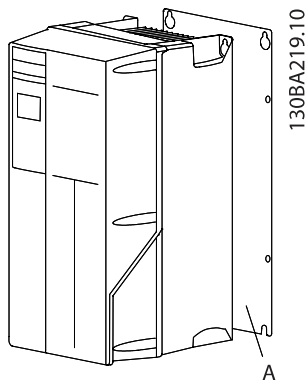

Illustration 2.2 Proper mounting with back plate

Item A is a back plate properly installed for required airflow to cool the unit.

2.4 Electrical Installation

This section contains detailed instructions for wiring the frequency converter. The following tasks are described.

- Wiring the motor to the frequency converter output terminals
- Wiring the AC mains to the frequency converter input terminals

- Connecting control and serial communication wiring
- After power has been applied, checking input and motor power; programming control terminals for their intended functions

Illustration 2.4 shows a basic electrical connection.

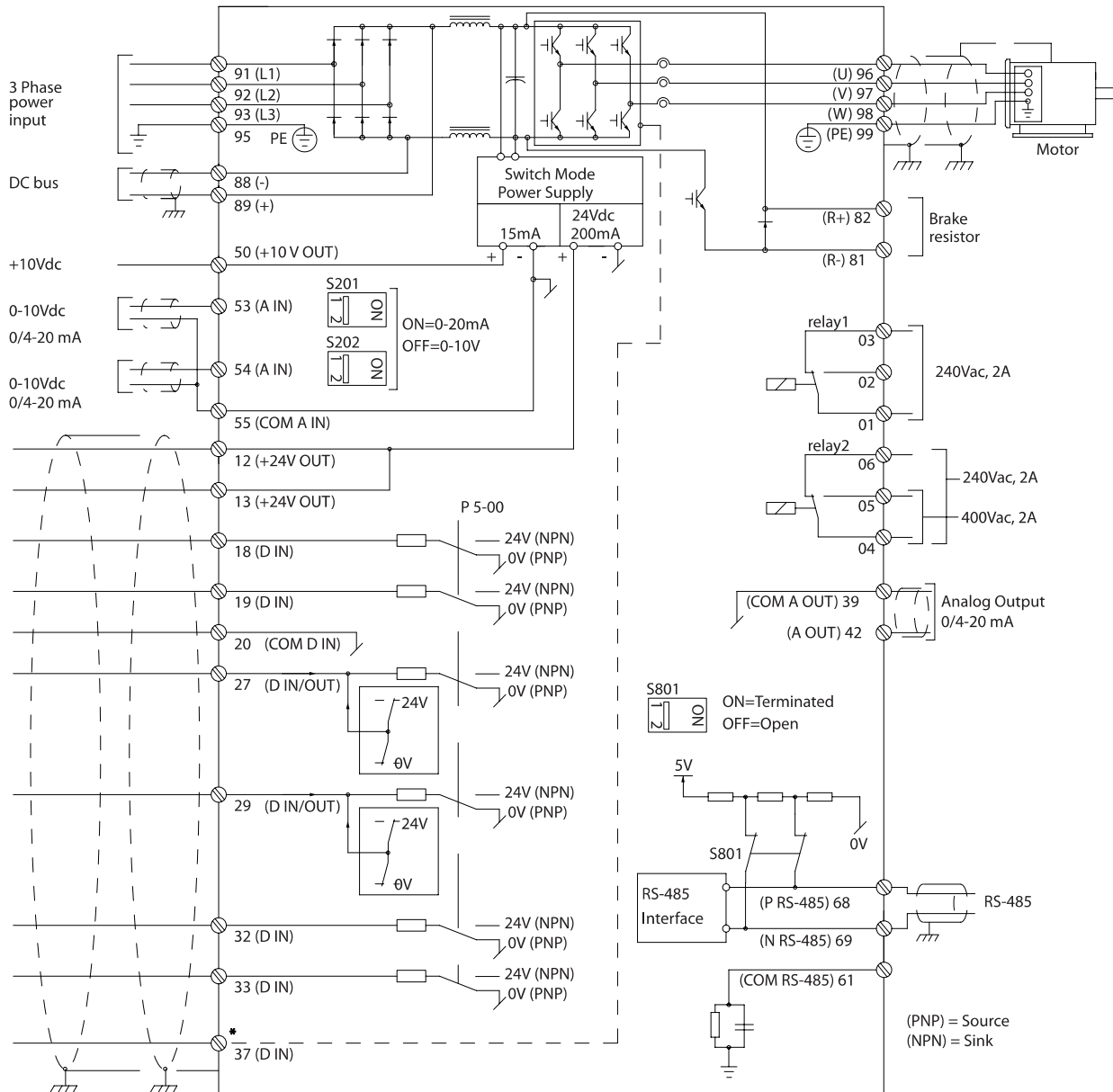

Illustration 2.4 Basic Wiring Schematic Drawing.

* Terminal 37 is an option

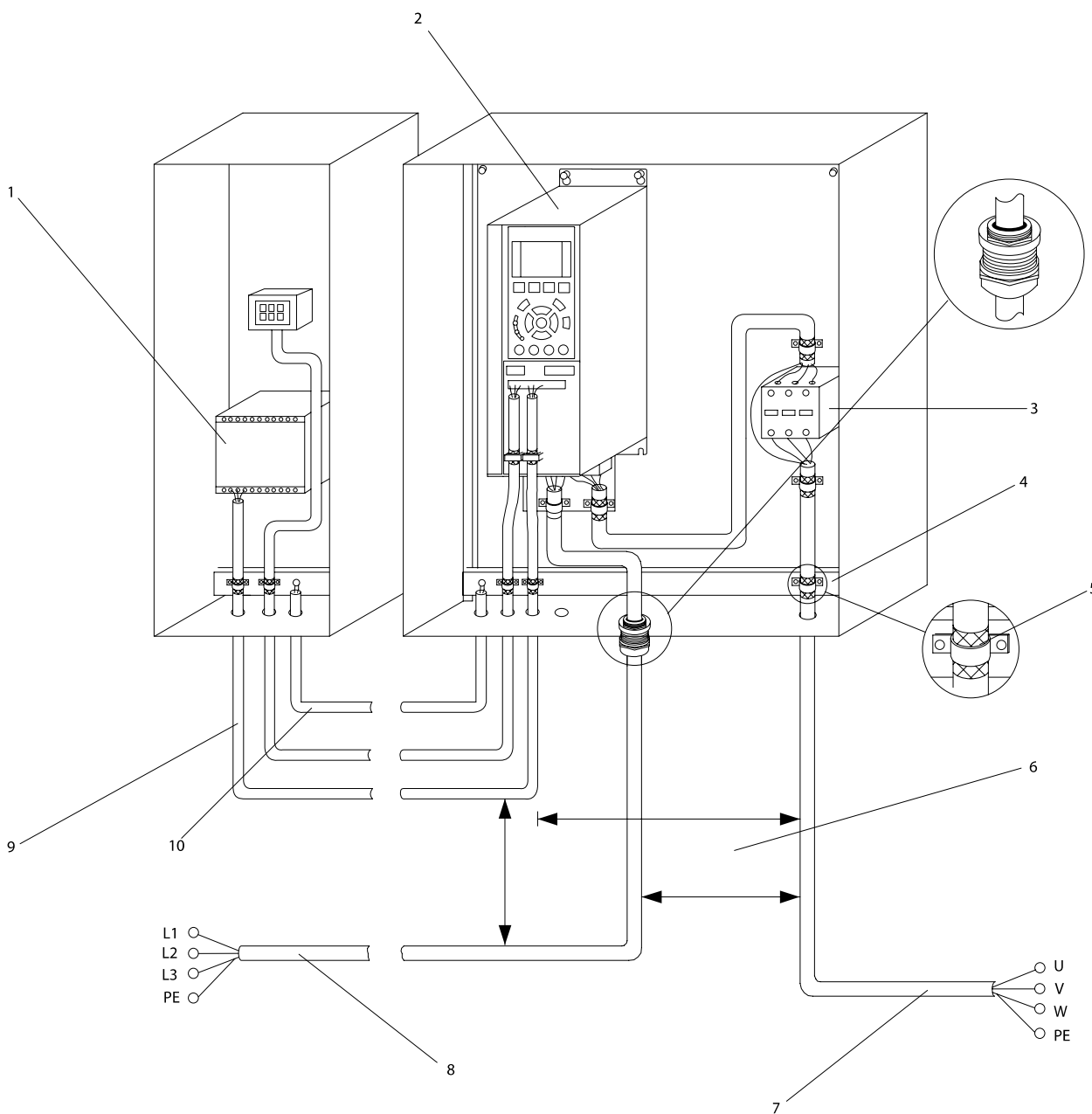

Illustration 2.5 Typical Electrical Connection

1	PLC	6	Min. 200mm (7.9in) between control cables, motor and mains
2	Frequency converter	7	Motor, 3-phase and PE
3	Output contactor (Generally not recommended)	8	Mains, 3-phase and reinforced PE
4	Earth (grounding) rail (PE)	9	Control wiring
5	Cable insulation (stripped)	10	Equalising min. 16mm ² (0.025in)

2.4.1 Requirements

WARNING

EQUIPMENT HAZARD!

Rotating shafts and electrical equipment can be hazardous. All electrical work must conform to national and local electrical codes. It is strongly recommended that installation, start up, and maintenance be performed only by trained and qualified personnel. Failure to follow these guidelines could result in death or serious injury.

CAUTION
WIRING ISOLATION!

Run input power, motor wiring and control wiring in three separate metallic conduits or use separated shielded cable for high frequency noise isolation. Failure to isolate power, motor and control wiring could result in less than optimum frequency converter and associated equipment performance.

For your safety, comply with the following requirements.

- Electronic controls equipment is connected to hazardous mains voltage. Extreme care should be taken to protect against electrical hazards when applying power to the unit.
- Run motor cables from multiple frequency converters separately. Induced voltage from output motor cables run together can charge equipment capacitors even with the equipment turned off and locked out.

Overload and Equipment Protection

- An electronically activated function within the frequency converter provides overload protection for the motor. The overload calculates the level of increase to activate timing for the trip (controller output stop) function. The higher the current draw, the quicker the trip response. The overload provides Class 20 motor protection. See *8 Warnings and Alarms* for details on the trip function.
- Because the motor wiring carries high frequency current, it is important that wiring for mains, motor power, and control are run separately. Use metallic conduit or separated shielded wire. Failure to isolate power, motor, and control wiring could result in less than optimum equipment performance. See *Illustration 2.6*.

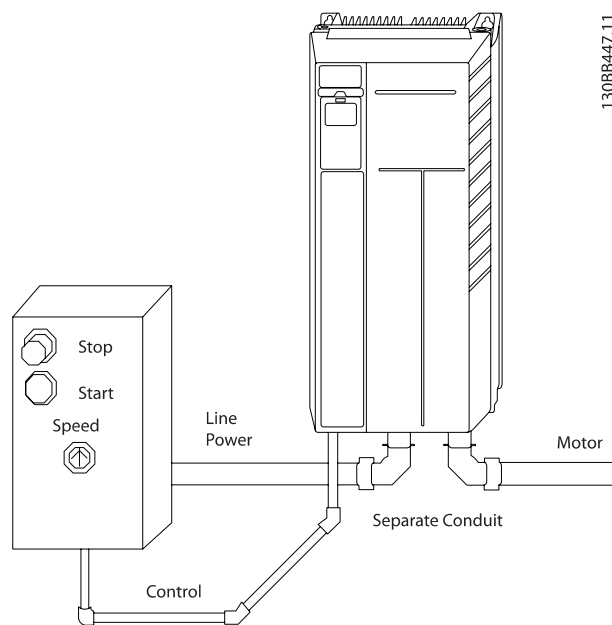

Illustration 2.6 Proper Electrical Installation Using Conduit

- All frequency converters must be provided with short-circuit and over-current protection. Input fusing is required to provide this protection, see *Illustration 2.7*. If not factory supplied, fuses must be provided by the installer as part of installation. See maximum fuse ratings in *10.3 Fuse Tables*.

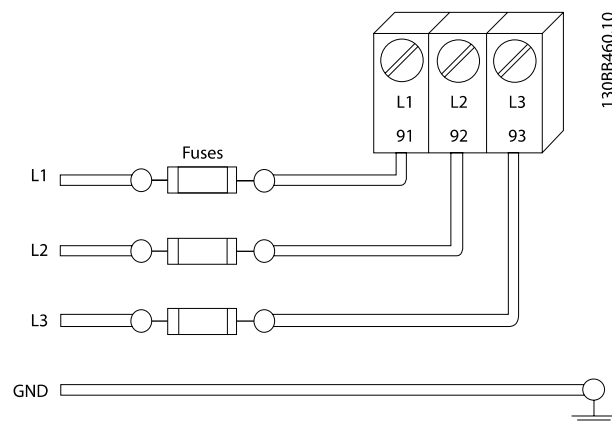

Illustration 2.7 Frequency converter Fuses

Wire Type and Ratings

- All wiring must comply with local and national regulations regarding cross-section and ambient temperature requirements.
- Danfoss recommends that all power connections be made with a minimum 75° C rated copper wire.
- See *10.1 Power-dependent Specifications* for recommended wire sizes.

2.4.2 Earth (Grounding) Requirements

⚠ WARNING

GROUNDING HAZARD!

For operator safety, it is important to ground frequency converter properly in accordance with national and local electrical codes as well as instructions contained within these instructions. Ground currents are higher than 3,5mA. Failure to ground frequency converter properly could result in death or serious injury.

NOTE

It is the responsibility of the user or certified electrical installer to ensure correct grounding (earthing) of the equipment in accordance with national and local electrical codes and standards.

- Follow all local and national electrical codes to ground electrical equipment properly
- Proper protective grounding for equipment with ground currents higher than 3,5mA must be established, see *Leakage Current (>3,5mA)*
- A dedicated ground wire is required for input power, motor power and control wiring
- Use the clamps provided with on the equipment for proper ground connections
- Do not ground one frequency converter to another in a "daisy chain" fashion
- Keep the ground wire connections as short as possible
- Use of high-strand wire to reduce electrical noise is recommended
- Follow motor manufacturer wiring requirements

2.4.2.1 Leakage Current (>3,5 mA)

Follow national and local codes regarding protective earthing of equipment with a leakage current > 3,5 mA. Frequency converter technology implies high frequency switching at high power. This will generate a leakage current in the earth connection. A fault current in the frequency converter at the output power terminals might contain a DC component which can charge the filter capacitors and cause a transient earth current. The earth leakage current depends on various system configurations including RFI filtering, screened motor cables, and frequency converter power.

EN/IEC61800-5-1 (Power Drive System Product Standard) requires special care if the leakage current exceeds 3,5mA. Earth grounding must be reinforced in one of the following ways:

- Earth ground wire of at least 10mm²
- Two separate earth ground wires both complying with the dimensioning rules

See EN/IEC61800-5-1 and EN50178 for further information.

Using RCDs

Where residual current devices (RCDs), also known as earth leakage circuit breakers (ELCBs), are used, comply with the following:

Use RCDs of type B only which are capable of detecting AC and DC currents

Use RCDs with an inrush delay to prevent faults due to transient earth currents

Dimension RCDs according to the system configuration and environmental considerations

2.4.2.2 Grounding Using Shielded Cable

Earthing (grounding) clamps are provided for motor wiring (see *Illustration 2.8*).

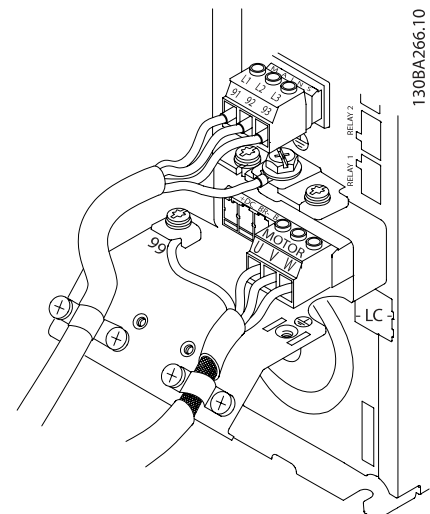

Illustration 2.8 Grounding with Shielded Cable

2.4.2.3 Grounding Using Conduit

⚠ CAUTION

GROUNDING HAZARD!

Do not use conduit connected to the frequency converter as a replacement for proper grounding. Ground currents are higher than 3,5mA. Improper grounding can result in personal injury or electrical shorts.

Dedicated grounding clamps are provided (See *Illustration 2.9*).

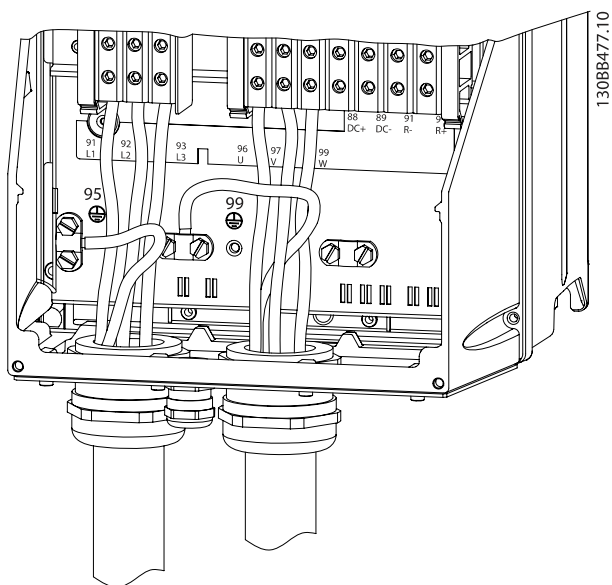

Illustration 2.9 Grounding with Conduit

1. Use a wire stripper to remove the insulation for proper grounding.
2. Secure the grounding clamp to the stripped portion of the wire with the screws provided.
3. Secure the grounding wire to the grounding clamp provided.

2.4.3 Motor Connection

⚠ WARNING

INDUCED VOLTAGE!

Run output motor cables from multiple frequency converters separately. Induced voltage from output motor cables run together can charge equipment capacitors even with the equipment turned off and locked out. Failure to run output motor cables separately could result in death or serious injury.

- For maximum wire sizes see 10.1 Power-dependent Specifications
- Comply with local and national electrical codes for cable sizes
- Motor wiring knockouts or access panels are provided at the base of IP21 and higher (NEMA1/12) units
- Do not install power factor correction capacitors between the frequency converter and the motor
- Do not wire a starting or pole-changing device between the frequency converter and the motor
- Connect the 3-phase motor wiring to terminals 96 (U), 97 (V), and 98 (W)

- Ground the cable in accordance with grounding instructions provided
- Torque terminals in accordance with the information provided in 10.4.1 Connection Tightening Torques
- Follow motor manufacturer wiring requirements

The three following illustrations represent mains input, motor, and earth grounding for basic frequency converters. Actual configurations vary with unit types and optional equipment.

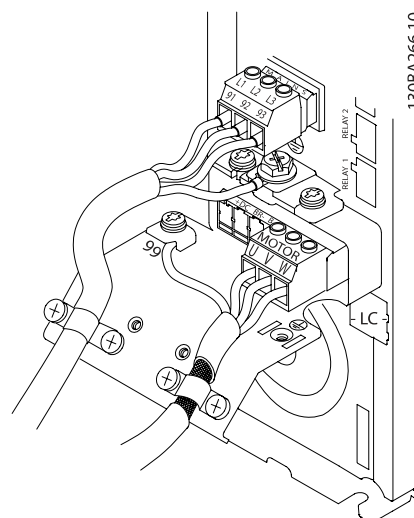

Illustration 2.10 Motor, Mains and Earth Wiring for A-Frame Sizes

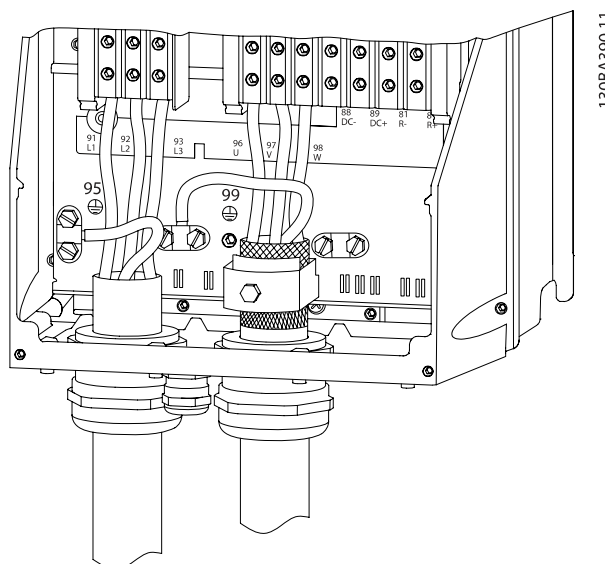

Illustration 2.11 Motor, Mains and Earth Wiring for B-Frame Sizes and Above Using Shielded Cable

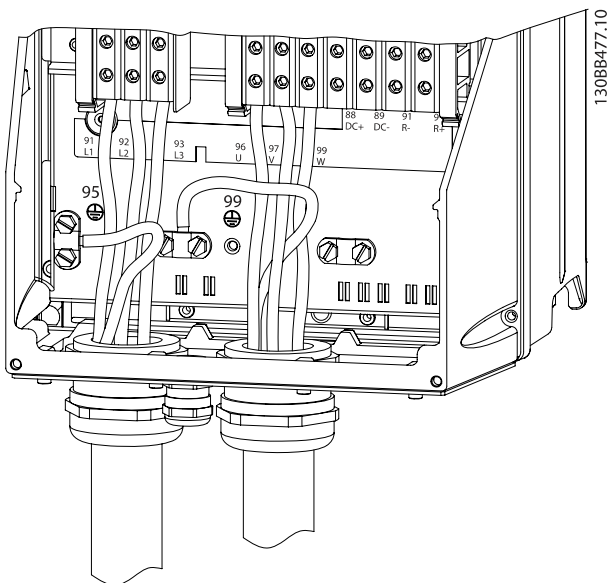

Illustration 2.12 Motor, Mains and Earth Wiring for B-Frame Sizes and Above Using Conduit

2.4.4 AC Mains Connection

- Size wiring based upon the input current of the frequency converter. See the maximum wire size in *10.1 Power-dependent Specifications*.
- Comply with local and national electrical codes for cable sizes.
- Connect 3-phase AC input power wiring to terminals L1, L2, and L3 (see *Illustration 2.13*).
- Depending on the configuration of the equipment, input power will be connected to the mains input terminals or the input disconnect.

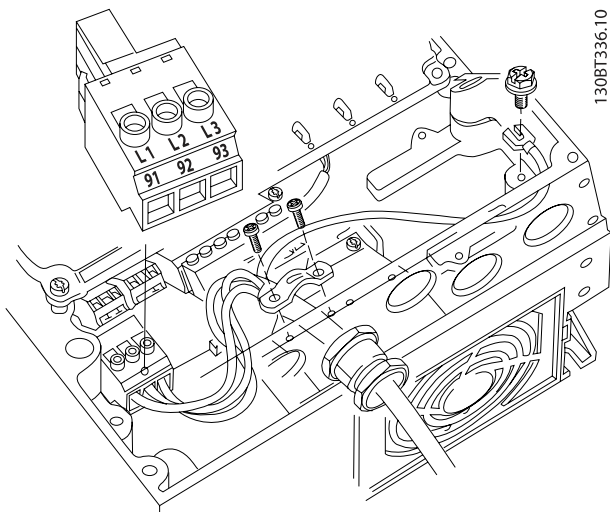

Illustration 2.13 Connecting to AC Mains

- Ground the cable in accordance with grounding instructions provided in *2.4.2 Earth (Grounding) Requirements*
- All frequency converters may be used with an isolated input source as well as with ground reference power lines. When supplied from an isolated mains source (IT mains or floating delta) or TT/TN-S mains with a grounded leg (grounded delta), set *14-50 RFI Filter* to OFF. When off, the internal RFI filter capacitors between the chassis and the intermediate circuit are isolated to avoid damage to the intermediate circuit and to reduce earth capacity currents in accordance with IEC 61800-3.

2.4.5 Control Wiring

- Isolate control wiring from high power components in the frequency converter.
- If the frequency converter is connected to a thermistor, for PELV isolation, optional thermistor control wiring must be reinforced/double insulated. A 24 VDC supply voltage is recommended.

2.4.5.1 Access

- Remove access cover plate with a screw driver. See *Illustration 2.14*.
- Or remove front cover by loosening attaching screws. See *Illustration 2.15*.

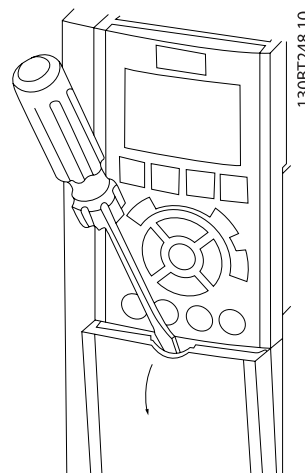

Illustration 2.14 Control Wiring Access for A2, A3, B3, B4, C3 and C4 enclosures

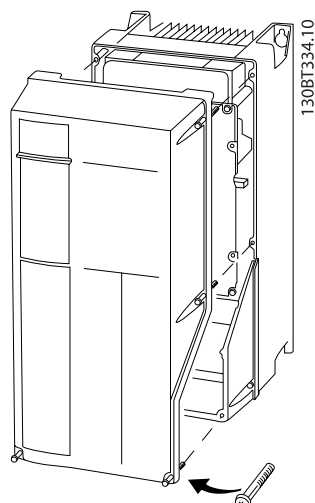

Illustration 2.15 Control Wiring Access for A4, A5, B1, B2, C1 and C2 enclosures

Please see Table 2.2 before tightening the covers.

Frame	IP20	IP21	IP55	IP66
A4/A5	-	-	2	2
B1	-	*	2.2	2.2
B2	-	*	2.2	2.2
C1	-	*	2.2	2.2
C2	-	*	2.2	2.2
* No screws to tighten				
- Does not exist				

Table 2.2 Tightening Torques for Covers (Nm)

2.4.5.2 Control Terminal Types

Illustration 2.19 shows the removable frequency converter connectors. Terminal functions and default settings are summarized in Table 2.3.

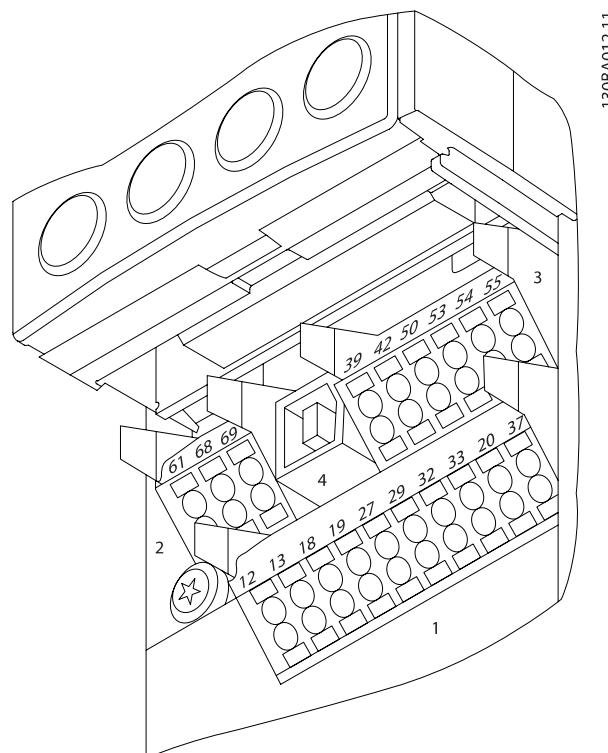

Illustration 2.16 Control Terminal Locations

- **Connector 1** provides four programmable digital inputs terminals, two additional digital terminals programmable as either input or output, a 24V DC terminal supply voltage, and a common for optional customer supplied 24V DC voltage
- **Connector 2** terminals (+)68 and (-)69 are for an RS-485 serial communications connection
- **Connector 3** provides two analog inputs, one analog output, 10V DC supply voltage, and commons for the inputs and output
- **Connector 4** is a USB port available for use with the MCT-10 Setup software
- Also provided are two Form C relay outputs that are in various locations depending upon the frequency converter configuration and size
- Some options available for ordering with the unit may provide additional terminals. See the manual provided with the equipment option.

See 10.2 General Technical Data for terminal ratings details.

Terminal Description			
Digital Inputs/Outputs			
Terminal	Parameter	Default Setting	Description
12, 13	-	+24V DC	24V DC supply voltage. Maximum output current is 200mA total for all 24V loads. Useable for digital inputs and external transducers.
18	5-10	[8] Start	Digital inputs.
19	5-11	[0] No operation	
32	5-14	[0] No operation	
33	5-15	[0] No operation	
27	5-12	[2] Coast inverse	Selectable for either digital input or output. Default setting is input.
29	5-13	[14] JOG	
20	-		Common for digital inputs and 0V potential for 24V supply.
37	-	Safe Torque Off (STO)	(optional) Safe input. Used for STO.
Analog Inputs/Outputs			
39	-		Common for analog output
42	6-50	Speed 0 - High Limit	Programmable analog output. The analog signal is 0-20mA or 4-20mA at a maximum of 500Ω
50	-	+10V DC	10V DC analog supply voltage. 15mA maximum commonly used for potentiometer or thermistor.
53	6-1	Reference	Analog input. Selectable for voltage or current. Switches A53 and A54 select mA or V.
54	6-2	Feedback	
55	-		Common for analog input
Serial Communication			
61	-		Integrated RC-Filter for cable screen. ONLY for connecting the screen when experiencing EMC problems.

Terminal Description			
Digital Inputs/Outputs			
Terminal	Parameter	Default Setting	Description
68 (+)	8-3		RS-485 Interface. A control card switch is provided for termination resistance.
69 (-)	8-3		
Relays			
01, 02, 03	5-40 [0]	[0] Alarm	Form C relay output. Usable for AC or DC voltage and resistive or inductive loads.
04, 05, 06	5-40 [1]	[0] Running	

Table 2.3 Terminal Description

2.4.5.3 Wiring to Control Terminals

Control terminal connectors can be unplugged from the frequency converter for ease of installation, as shown in *Illustration 2.17*.

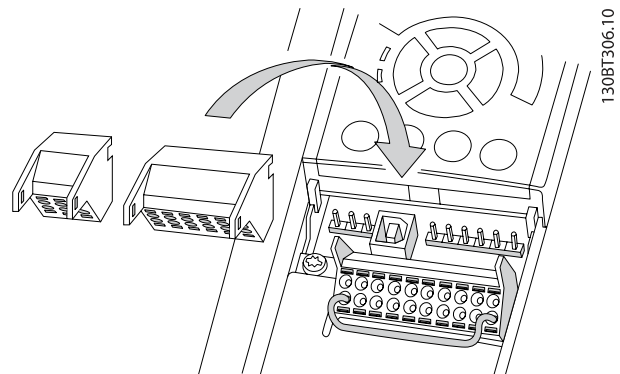

Illustration 2.17 Unplugging Control Terminals

1. Open the contact by inserting a small screwdriver into the slot above or below the contact, as shown in the following illustration.
2. Insert the bared control wire into the contact.
3. Remove the screwdriver to fasten the control wire into the contact.
4. Ensure the contact is firmly established and not loose. Loose control wiring can be the source of equipment faults or less than optimal operation.

See *10.1 Power-dependent Specifications* for control terminal wiring sizes.

See *6 Application Set-Up Examples* for typical control wiring connections.

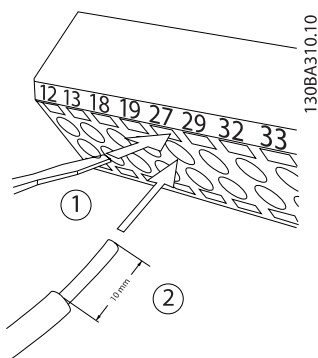

Illustration 2.18 Connecting Control Wiring

associated with that terminal. See Table 2.3 for terminals and associated parameters.

- It is important to confirm that the control terminal is programmed for the correct function. See 4 User Interface for details on accessing parameters and 5 About Frequency Converter Programming for details on programming.
- The default terminal programming is intended to initiate frequency converter functioning in a typical operational mode.

2.4.5.4 Using Screened Control Cables

Correct screening

The preferred method in most cases is to secure control and serial communication cables with screening clamps provided at both ends to ensure best possible high frequency cable contact.

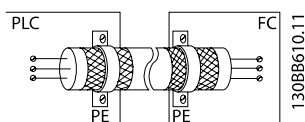

50/60 Hz ground loops

With very long control cables, ground loops may occur. To eliminate ground loops, connect one end of the screen-to-ground with a 100 nF capacitor (keeping leads short).

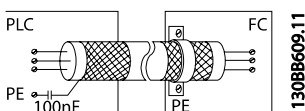

Avoid EMC noise on serial communication

To eliminate low-frequency noise between frequency converters, connect one end of the screen to terminal 61. This terminal is connected to ground via an internal RC link. Use twisted-pair cables to reduce interference between conductors.

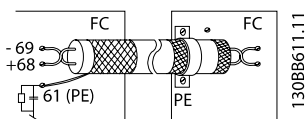

2.4.5.5 Control Terminal Functions

Frequency converter functions are commanded by receiving control input signals.

- Each terminal must be programmed for the function it will be supporting in the parameters

2.4.5.6 Jumper Terminals 12 and 27

A jumper wire may be required between terminal 12 (or 13) and terminal 27 for the frequency converter to operate when using factory default programming values.

- Digital input terminal 27 is designed to receive an 24VDC external interlock command. In many applications, the user wires an external interlock device to terminal 27
- When no interlock device is used, wire a jumper between control terminal 12 (recommended) or 13 to terminal 27. This provides an internal 24 V signal on terminal 27
- No signal present prevents the unit from operating
- When the status line at the bottom of the LCP reads AUTO REMOTE COASTING or Alarm 60 External Interlock is displayed, this indicates that the unit is ready to operate but is missing an input signal on terminal 27.
- When factory installed optional equipment is wired to terminal 27, do not remove that wiring

2.4.5.7 Terminal 53 and 54 Switches

- Analog input terminals 53 and 54 can select either voltage (0 to 10V) or current (0/4-20mA) input signals
- Remove power to the frequency converter before changing switch positions
- Set switches A53 and A54 to select the signal type. U selects voltage, I selects current.
- The switches are accessible when the LCP has been removed (see Illustration 2.19). Note that some option cards available for the unit may cover these switches and must be removed to change switch settings. Always remove power to the unit before removing option cards.
- Terminal 53 default is for a speed reference signal in open loop set in 16-61 Terminal 53 Switch Setting
- Terminal 54 default is for a feedback signal in closed loop set in 16-63 Terminal 54 Switch Setting

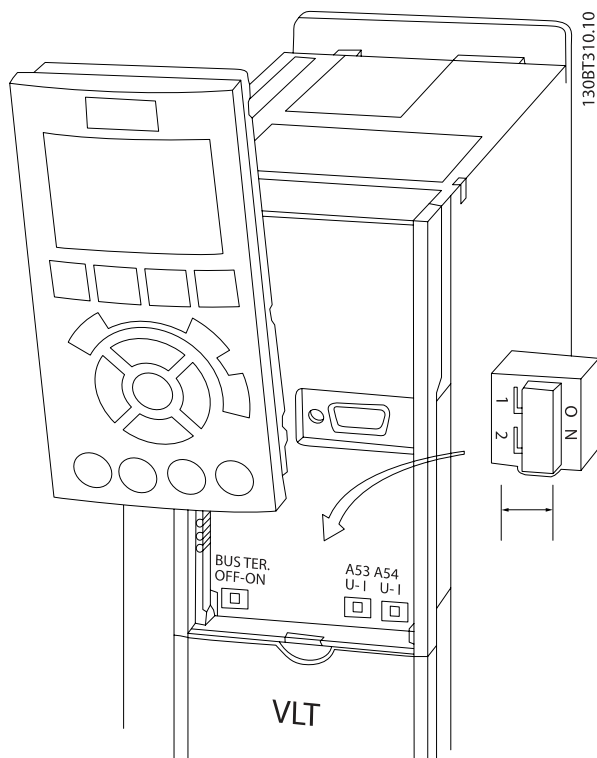

Illustration 2.19 Location of Terminals 53 and 54 Switches

2.4.5.8 Terminal 37

Terminal 37 Safe Stop Function

The FC 102 is available with optional safe stop functionality via control terminal 37. Safe stop disables the control voltage of the power semiconductors of the frequency controller output stage which in turn prevents generating the voltage required to rotate the motor. When the Safe Stop (T37) is activated, the frequency converter issues an alarm, trips the unit, and coasts the motor to a stop. Manual restart is required. The safe stop function can be used for stopping the frequency converter in emergency stop situations. In the normal operating mode when safe stop is not required, use the frequency converter's regular stop function instead. When automatic restart is used – the requirements according to ISO 12100-2 paragraph 5.3.2.5 must be fulfilled.

Liability Conditions

It is the responsibility of the user to ensure personnel installing and operating the Safe Stop function:

- Read and understand the safety regulations concerning health and safety/accident prevention
- Understand the generic and safety guidelines given in this description and the extended description in the *Design Guide*
- Have a good knowledge of the generic and safety standards applicable to the specific application

User is defined as: integrator, operator, servicing, maintenance staff.

Standards

Use of safe stop on terminal 37 requires that the user satisfies all provisions for safety including relevant laws, regulations and guidelines. The optional safe stop function complies with the following standards.

EN 954-1: 1996 Category 3

IEC 60204-1: 2005 category 0 – uncontrolled stop

IEC 61508: 1998 SIL2

IEC 61800-5-2: 2007 – safe torque off (STO) function

IEC 62061: 2005 SIL CL2

ISO 13849-1: 2006 Category 3 PL d

ISO 14118: 2000 (EN 1037) – prevention of unexpected start up

The information and instructions of the instruction manual are not sufficient for a proper and safe use of the safe stop functionality. The related information and instructions of the relevant *Design Guide* must be followed.

Protective Measures

- Safety engineering systems may only be installed and commissioned by qualified and skilled personnel
- The unit must be installed in an IP54 cabinet or in an equivalent environment
- The cable between terminal 37 and the external safety device must be short circuit protected according to ISO 13849-2 table D.4
- If any external forces influence the motor axis (e.g. suspended loads), additional measures (e.g., a safety holding brake) are required in order to eliminate hazards

Safe Stop Installation and Set-Up



Safe Stop Function!

The safe stop function does NOT isolate mains voltage to the frequency converter or auxiliary circuits. Perform work on electrical parts of the frequency converter or the motor only after isolating the mains voltage supply and waiting the length of time specified under Safety in this manual. Failure to isolate the mains voltage supply from the unit and waiting the time specified could result in death or serious injury.

- It is not recommended to stop the frequency converter by using the Safe Torque Off function. If a running frequency converter is stopped by using the function, the unit will trip and stop by coasting. If this is not acceptable, e.g. causes danger, the frequency converter and machinery must be stopped using the appropriate stopping mode

before using this function. Depending on the application a mechanical brake may be required.

- Concerning synchronous and permanent magnet motor frequency converters in case of a multiple IGBT power semiconductor failure: In spite of the activation of the Safe torque off function, the frequency converter system can produce an alignment torque which maximally rotates the motor shaft by $180/p$ degrees. p denotes the pole pair number.
- This function is suitable for performing mechanical work on the frequency converter system or affected area of a machine only. It does not provide electrical safety. This function should not be used as a control for starting and/or stopping the frequency converter.

The following requirements have to be met to perform a safe installation of the frequency converter:

1. Remove the jumper wire between control terminals 37 and 12 or 13. Cutting or breaking the jumper is not sufficient to avoid short-circuiting. (See jumper on *Illustration 2.20*.)
2. Connect an external Safety monitoring relay via a NO safety function (the instruction for the safety device must be followed) to terminal 37 (safe stop) and either terminal 12 or 13 (24V DC). The Safety monitoring relay must comply with Category 3 (EN 954-1) / PL "d" (ISO 13849-1).

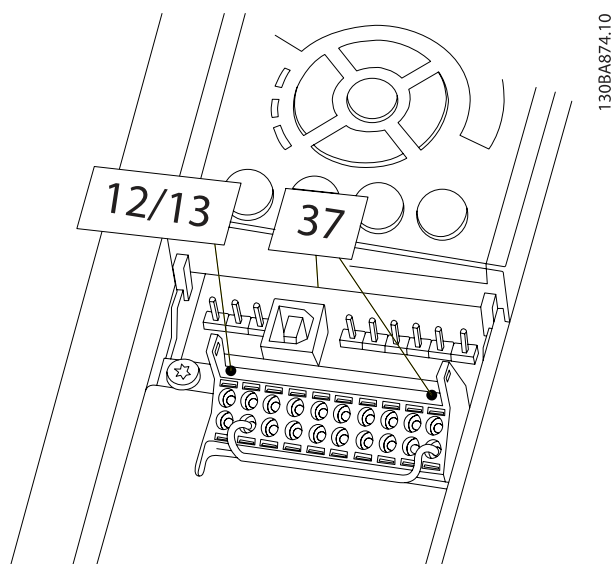
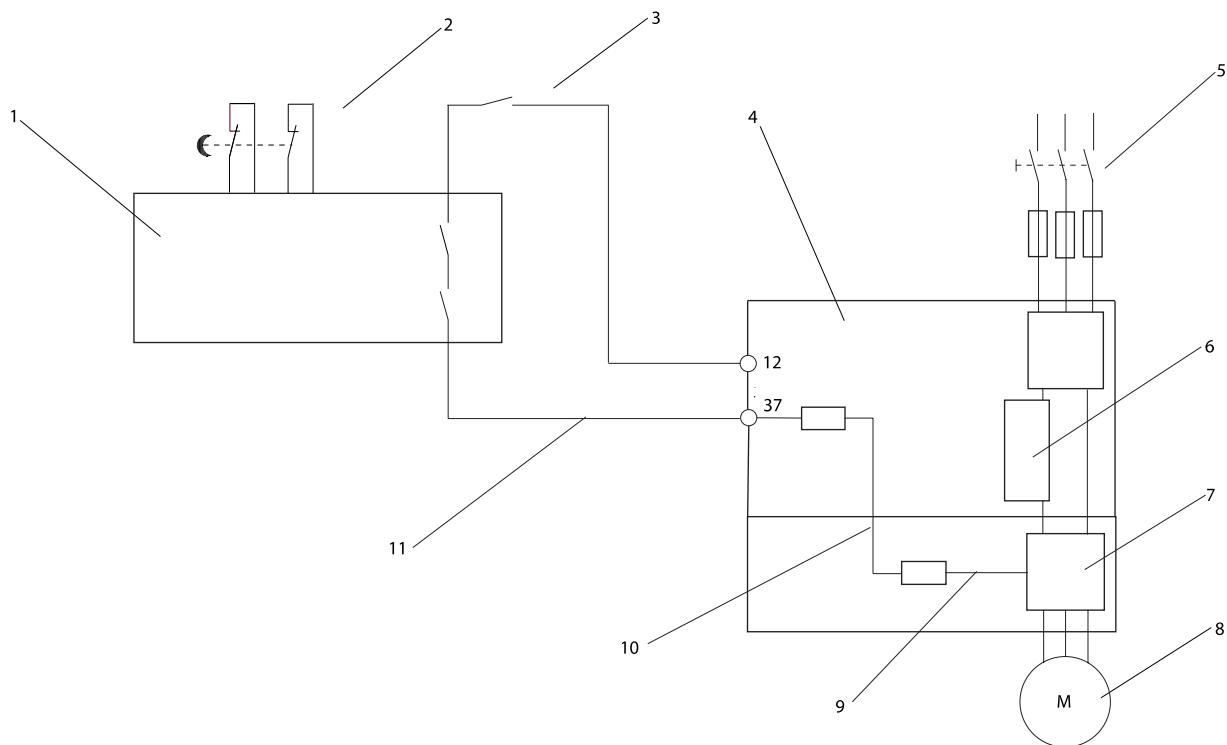

Illustration 2.20 Jumper Between Terminal 12/13 (24 V) and 37



13088749.10

2

Illustration 2.21 Installation to Achieve a Stopping Category 0 (EN 60204-1) with Safety Cat. 3 (EN 954-1) / PL "d" (ISO 13849-1).

1	Safety device Cat. 3 (circuit interrupt device, possibly with release input)	7	Inverter
2	Door contact	8	Motor
3	Contactora (Coast)	9	5V DC
4	Frequency converter	10	Safe channel
5	Mains	11	Short-circuit protected cable (if not inside installation cabinet)
6	Control board		

Safe Stop Commissioning Test

After installation and before first operation, perform a commissioning test of the installation making use of safe stop. Moreover, perform the test after each modification of the installation.

2.4.6 Serial Communication

Connect RS-485 serial communication wiring to terminals (+)68 and (-)69.

2

- Screened serial communication cable is recommended
- See 2.4.2 *Earth (Grounding) Requirements* for proper grounding

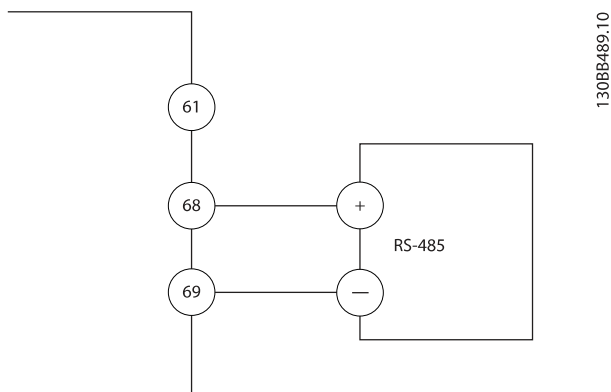

Illustration 2.22 Serial Communication Wiring Diagram

For basic serial communication set-up, select the following

1. Protocol type in 8-30 *Protocol*.
 2. Frequency converter address in 8-31 *Address*.
 3. Baud rate in 8-32 *Baud Rate*.
- Four communication protocols are internal to the frequency converter. Follow motor manufacturer wiring requirements.
 - Danfoss FC
 - Modbus RTU
 - Johnson Controls N2®
 - Siemens FLN®
 - Functions can be programmed remotely using the protocol software and RS-485 connection or in parameter group 8-** *Communications and Options*
 - Selecting a specific communication protocol changes various default parameter settings to match that protocol's specifications along with making additional protocol-specific parameters available
 - Option cards which install into the frequency converter are available to provide additional communication protocols. See the option-card documentation for installation and operation instructions

3 Start Up and Functional Testing

3.1 Pre-start

3.1.1 Safety Inspection



HIGH VOLTAGE!

If input and output connections have been connected improperly, there is potential for high voltage on these terminals. If power leads for multiple motors are improperly run in same conduit, there is potential for leakage current to charge capacitors within the frequency converter, even when disconnected from mains input. For initial start up, make no assumptions about power components. Follow pre-start procedures. Failure to follow pre-start procedures could result in personal injury or damage to equipment.

1. Input power to the unit must be OFF and locked out. Do not rely on the frequency converter disconnect switches for input power isolation.
2. Verify that there is no voltage on input terminals L1 (91), L2 (92), and L3 (93), phase-to-phase and phase-to-ground,
3. Verify that there is no voltage on output terminals 96 (U), 97(V), and 98 (W), phase-to-phase and phase-to-ground.
4. Confirm continuity of the motor by measuring ohm values on U-V (96-97), V-W (97-98), and W-U (98-96).
5. Check for proper grounding of the frequency converter as well as the motor.
6. Inspect the frequency converter for loose connections on terminals.
7. Record the following motor-nameplate data: power, voltage, frequency, full load current, and nominal speed. These values are needed to program motor nameplate data later.
8. Confirm that the supply voltage matches voltage of frequency converter and motor.

3.1.2 Start Up Check List

CAUTION

Before applying power to the unit, inspect the entire installation as detailed in *Table 3.1*. Check mark those items when completed.

3

Inspect for	Description	<input checked="" type="checkbox"/>
Auxiliary equipment	<ul style="list-style-type: none"> Look for auxiliary equipment, switches, disconnects, or input fuses/circuit breakers that may reside on input power side of frequency converter or output side to motor. Examine their operational readiness and ensure that they are ready in all respects for operation at full speed. Check function and installation of any sensors used for feedback to frequency converter Remove power factor correction caps on motor(s), if present 	
Cable routing	<ul style="list-style-type: none"> Ensure that input power, motor wiring, and control wiring are separated or in three separate metallic conduits for high frequency noise isolation 	
Control wiring	<ul style="list-style-type: none"> Check for broken or damaged wires and loose connections Check that control wiring is isolated from power and motor wiring for noise immunity Check the voltage source of the signals, if necessary The use of shielded cable or twisted pair is recommended. Ensure that the shield is terminated correctly. 	
Cooling clearance	<ul style="list-style-type: none"> Measure that top and bottom clearance is adequate to ensure proper air flow for cooling 	
EMC considerations	<ul style="list-style-type: none"> Check for proper installation regarding electromagnetic compatibility 	
Environmental considerations	<ul style="list-style-type: none"> See equipment label for the maximum ambient operating temperature limits Humidity levels must be 5-95% non-condensing 	
Fusing and circuit breakers	<ul style="list-style-type: none"> Check for proper fusing or circuit breakers Check that all fuses are inserted firmly and in operational condition and that all circuit breakers are in the open position 	
Grounding	<ul style="list-style-type: none"> The unit requires a ground wire from its chassis to the building ground Check for good ground connections that are tight and free of oxidation Grounding to conduit or mounting the back panel to a metal surface is not a suitable ground 	
Input and output power wiring	<ul style="list-style-type: none"> Check for loose connections Check that motor and mains are in separate conduit or separated screened cables 	
Panel interior	<ul style="list-style-type: none"> Inspect that the unit interior is free of dirt, metal chips, moisture, and corrosion 	
Switches	<ul style="list-style-type: none"> Ensure that all switch and disconnect settings are in the proper position 	
Vibration	<ul style="list-style-type: none"> Check that the unit is mounted solidly or that shock mounts are used, as necessary Look for any unusual amount of vibration the unit may be subjected to 	

Table 3.1 Start Up Check List

3.2 Applying Power to the Frequency Converter

WARNING

HIGH VOLTAGE!

Frequency converters contain high voltage when connected to AC mains. Installation, start-up and maintenance should be performed by qualified personnel only. Failure to perform installation, start-up and maintenance by qualified personnel could result in death or serious injury.

WARNING

UNINTENDED START!

When frequency converter is connected to AC mains, the motor may start at any time. The frequency converter, motor, and any driven equipment must be in operational readiness. Failure to be in operational readiness when the frequency converter is connected to AC mains could result in death, serious injury, equipment, or property damage.

1. Confirm input voltage is balanced within 3%. If not, correct input voltage imbalance before proceeding. Repeat procedure after voltage correction.
2. Ensure optional equipment wiring, if present, matches installation application.
3. Ensure that all operator devices are in the OFF position. Panel doors closed or cover mounted.
4. Apply power to the unit. DO NOT start the frequency converter at this time. For units with a disconnect switch, turn to the ON position to apply power to the frequency converter.

NOTE

If the status line at the bottom of the LCP reads **AUTO REMOTE COASTING** or **Alarm 60 External Interlock** is displayed, this indicates that the unit is ready to operate but is missing an input signal on terminal 27. See *Illustration 2.20* for details.

3.3 Basic Operational Programming

Frequency converters require basic operational programming prior to running for best performance. Basic operational programming requires entering motor-nameplate data for the motor being operated and the minimum and maximum motor speeds. Enter data in accordance with the following procedure. Parameter settings recommended are intended for start up and checkout purposes. Application settings may vary. See *4 User Interface* for detailed instructions on entering data through the LCP.

Enter data with power ON, but prior to operating the frequency converter.

1. Press [Main Menu] twice on the LCP.
2. Use the navigation keys to scroll to parameter group 0-** *Operation/Display* and press [OK].

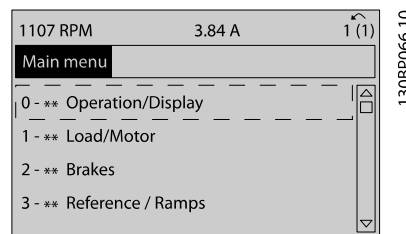

3. Use navigation keys to scroll to parameter group 0-0* *Basic Settings* and press [OK].

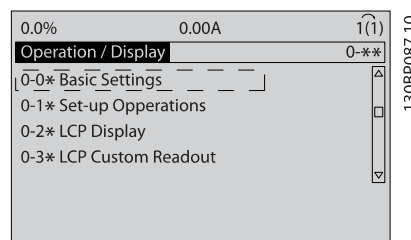

4. Use navigation keys to scroll to 0-03 *Regional Settings* and press [OK].

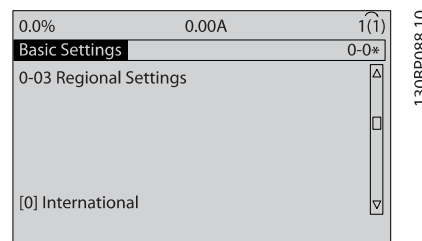

5. Use navigation keys to select *International* or *North America* as appropriate and press [OK]. (This changes the default settings for a number of basic parameters. See *5.4 International/North American Default Parameter Settings* for a complete list.)
6. Press [Quick Menu] on the LCP.

- Use the navigation keys to scroll to parameter group **Q2 Quick Setup** and press [OK].

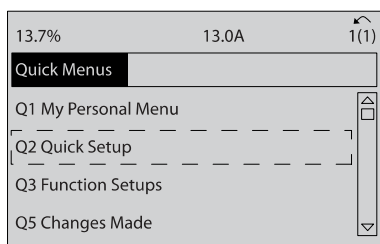

- Select language and press [OK]. Then enter the motor data in parameters 1-20/1-21 through 1-25. The information can be found on the motor nameplate. The entire quick menu is shown in *5.5.1 Quick Menu Structure*

1-20 Motor Power [kW] or 1-21 Motor Power [HP]

1-22 Motor Voltage

1-23 Motor Frequency

1-24 Motor Current

1-25 Motor Nominal Speed

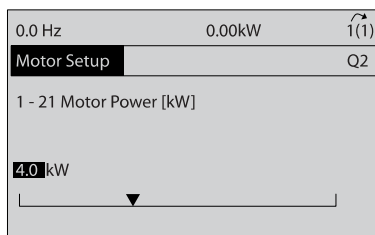

- For best results, skip *1-28 Motor Rotation Check* at this time until basic programming is complete. This will be tested following basic set-up.
- 3-41 Ramp 1 Ramp Up Time* is recommended as 60 seconds for fans or 10 seconds for pumps.
- 3-42 Ramp 1 Ramp Down Time* is recommended as 60 seconds for fans or 10 seconds for pumps.
- For *4-12 Motor Speed Low Limit [Hz]* enter the application requirements. If these values are unknown at this time, the following values are recommended. These values will ensure initial frequency converter operation. However, take any precautions necessary to prevent equipment damage. Make sure that the recommended values are safe to use for functional testing before starting the equipment.
 - Fan = 20Hz
 - Pump = 20Hz
 - Compressor = 30Hz
- In *4-14 Motor Speed High Limit [Hz]* enter the motor frequency from *1-23 Motor Frequency*.

- Leave *3-11 Jog Speed [Hz]* (10Hz) at the factory default (this is not used in initial programming).
- A jumper wire should be in place between control terminals 12 and 27. If this is the case, leave *5-12 Terminal 27 Digital Input* at factory default. Otherwise select *No Operation*. For frequency converters with an optional Danfoss bypass, no jumper wire is required.
- 5-40 Function Relay*, leave at factory default.

This concludes the quick set-up procedure. Press [Status] to return to the operational display.

3.4 Automatic Motor Adaptation

Automatic motor adaptation (AMA) is a test procedure that measures the electrical characteristics of the motor to optimize compatibility between the frequency converter and the motor.

- The frequency converter builds a mathematical model of the motor for regulating output motor current. The procedure also tests the input phase balance of electrical power. It compares the motor characteristics with the data entered in parameters 1-20 to 1-25.
- It does not cause the motor to run or harm to the motor
- Some motors may be unable to run the complete version of the test. In that case, select *Enable reduced AMA*
- If an output filter is connected to the motor, select *Enable reduced AMA*
- If warnings or alarms occur, see *8 Warnings and Alarms*
- Run this procedure on a cold motor for best results

To run AMA

- Press [Main Menu] to access parameters.
- Scroll to 1-** *Load and Motor*.
- Press [OK].
- Scroll to 1-2* *Motor Data*.
- Press [OK].
- Scroll to 1-29 *Automatic Motor Adaptation (AMA)*.
- Press [OK].
- Select *Enable complete AMA*.
- Press [OK].
- Follow on-screen instructions.
- The test will run automatically and indicate when it is complete.

3.5 Check Motor Rotation

Prior to running the frequency converter, check the motor rotation. The motor will run briefly at 5Hz or the minimum frequency set in 4-12 *Motor Speed Low Limit [Hz]*.

1. Press [Quick Menu].
2. Scroll to *Q2 Quick Setup*.
3. Press [OK].
4. Scroll to *1-28 Motor Rotation Check*.
5. Press [OK].
6. Scroll to *Enable*.

The following text will appear: *Note! Motor may run in wrong direction.*

7. Press [OK].
8. Follow the on-screen instructions.

To change the direction of rotation, remove power to the frequency converter and wait for power to discharge. Reverse the connection of any two of the three motor cables on the motor or frequency converter side of the connection.

3.6 Local-control Test



MOTOR START!

Ensure that the motor, system, and any attached equipment is ready for start. It is the responsibility of the user to ensure safe operation under any operational condition. Failure to ensure that the motor, system, and any attached equipment is ready for start could result in personal injury or equipment damage.

NOTE

The hand on key on the LCP provides a local start command to the frequency converter. The OFF key provides the stop function.

When operating in local mode, the up and down arrows on the LCP increase and decrease the speed output of the frequency converter. The left and right arrow keys move the display cursor in the numeric display.

1. Press [Hand ON].
2. Accelerate the frequency converter by pressing [▲] to full speed. Moving the cursor left of the decimal point provides quicker input changes.
3. Note any acceleration problems.
4. Press [OFF].
5. Note any deceleration problems.

If acceleration problems were encountered

- If warnings or alarms occur, see 8 *Warnings and Alarms*
- Check that motor data is entered correctly
- Increase the ramp-up time in 3-41 *Ramp 1 Ramp Up Time*
- Increase current limit in 4-18 *Current Limit*
- Increase torque limit in 4-16 *Torque Limit Motor Mode*

If deceleration problems were encountered

- If warnings or alarms occur, see 8 *Warnings and Alarms*
- Check that motor data is entered correctly
- Increase the ramp-down time in 3-42 *Ramp 1 Ramp Down Time*
- Enable overvoltage control in 2-17 *Over-voltage Control*

See 8.4 *Warning and Alarm Definitions* for resetting the frequency converter after a trip.

NOTE

3.1 *Pre-start* through 3.6 *Local-control Test* in this chapter concludes the procedures for applying power to the frequency converter, basic programming, set-up, and functional testing.

3.7 System Start Up

The procedure in this section requires user-wiring and application programming to be completed. *6 Application Set-Up Examples* is intended to help with this task. Other aids to application set-up are listed in *1.2 Additional Resources*. The following procedure is recommended after application set-up by the user is completed.

3

⚠ CAUTION

MOTOR START!

Ensure that the motor, system, and any attached equipment is ready for start. It is the responsibility of the user to ensure safe operation under any operational condition. Failure to ensure that the motor, system, and any attached equipment is ready for start could result in personal injury or equipment damage.

1. Press [Auto On].
2. Ensure that external control functions are properly wired to the frequency converter and all programming completed.
3. Apply an external run command.
4. Adjust the speed reference throughout the speed range.
5. Remove the external run command.
6. Note any problems.

If warnings or alarms occur, see *8 Warnings and Alarms*.

4 User Interface

4.1 Local Control Panel

The local control panel (LCP) is the combined display and keypad on the front of the unit. The LCP is the user interface to the frequency converter.

The LCP has several user functions.

- Start, stop, and control speed when in local control
- Display operational data, status, warnings and cautions
- Programming frequency converter functions
- Manually reset the frequency converter after a fault when auto-reset is inactive

An optional numeric LCP (NLCP) is also available. The NLCP operates in a manner similar to the LCP. See the Programming Guide for details on use of the NLCP.

4.1.1 LCP Layout

The LCP is divided into four functional groups (see illustration).

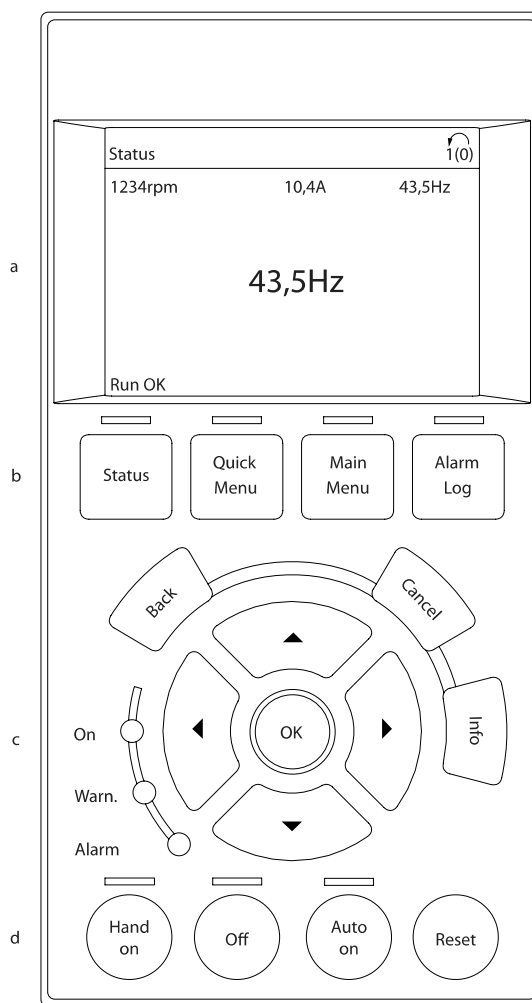

1308B465.10

Illustration 4.1 LCP

- Display area
- Display menu keys for changing the display to show status options, programming, or error message history.
- Navigation keys for programming functions, moving the display cursor, and speed control in local operation. Also included are the status indicator lights.
- Operational mode keys and reset.

4.1.2 Setting LCP Display Values

The display area is activated when the frequency converter receives power from mains voltage, a DC bus terminal, or an external 24V supply.

The information displayed on the LCP can be customized for user application.

- Each display readout has a parameter associated with it.
- Options are selected in the quick menu Q3-13 *Display Settings*.
- Display 2 has an alternate larger display option.
- The frequency converter status at the bottom line of the display is generated automatically and is not selectable. See 7 *Status Messages* for definitions and details.

Display	Parameter number	Default setting
1.1	0-20	Motor RPMs
1.2	0-21	Motor current
1.3	0-22	Motor power (kW)
2	0-23	Motor frequency
3	0-24	Reference in percent

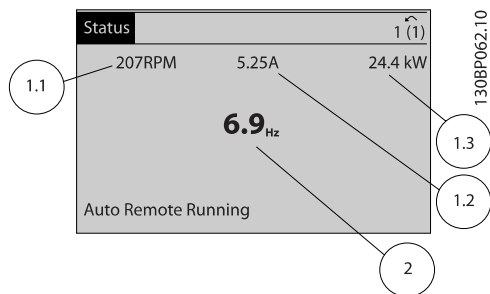
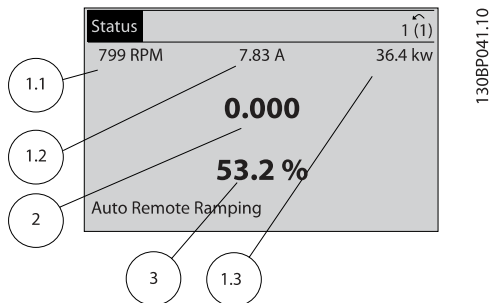

4.1.3 Display Menu Keys

Menu keys are used for menu access for parameter set-up, toggling through status display modes during normal operation, and viewing fault log data.



Key	Function
Status	<p>Press to show operational information.</p> <ul style="list-style-type: none"> • In Auto mode, press and hold to toggle between status read-out displays • Press repeatedly to scroll through each status display • Press and hold [Status] plus [▲] or [▼] to adjust the display brightness • The symbol in the upper right corner of the display shows the direction of motor rotation and which set-up is active. This is not programmable.
Quick Menu	<p>Allows access to programming parameters for initial set up instructions and many detailed application instructions.</p> <ul style="list-style-type: none"> • Press to access Q2 <i>Quick Setup</i> for sequenced instructions to program the basic frequency controller set up • Press to access Q3 <i>Function Setups</i> for sequenced instructions to program applications • Follow the sequence of parameters as presented for the function set up
Main Menu	<p>Allows access to all programming parameters.</p> <ul style="list-style-type: none"> • Press twice to access top-level index • Press once to return to the last location accessed • Press and hold to enter a parameter number for direct access to that parameter
Alarm Log	<p>Displays a list of current warnings, the last 10 alarms, and the maintenance log.</p> <ul style="list-style-type: none"> • For details about the frequency converter before it entered the alarm mode, select the alarm number using the navigation keys and press [OK].

4.1.4 Navigation Keys

Navigation keys are used for programming functions and moving the display cursor. The navigation keys also provide speed control in local (hand) operation. Three frequency converter status indicator lights are also located in this area.

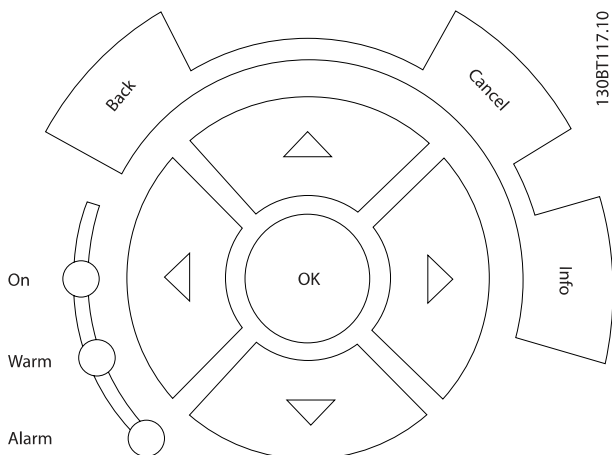

Key	Function
Back	Reverts to the previous step or list in the menu structure.
Cancel	Cancels the last change or command as long as the display mode has not changed.
Info	Press for a definition of the function being displayed.
Navigation Keys	Use the four navigation arrows to move between items in the menu.
OK	Use to access parameter groups or to enable a choice.

Light	Indicator	Function
Green	ON	The ON light activates when the frequency converter receives power from mains voltage, a DC bus terminal, or an external 24 V supply.
Yellow	WARN	When warning conditions are met, the yellow WARN light comes on and text appears in the display area identifying the problem.
Red	ALARM	A fault condition causes the red alarm light to flash and an alarm text is displayed.

4.1.5 Operation Keys

Operation keys are found at the bottom of the control panel.

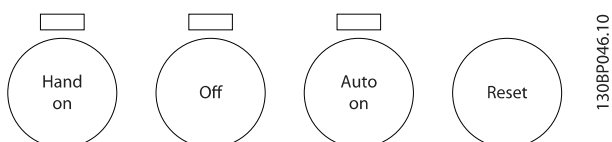

Key	Function
Hand On	Press to start the frequency converter in local control. <ul style="list-style-type: none"> Use the navigation keys to control frequency converter speed An external stop signal by control input or serial communication overrides the local hand on
Off	Stops the motor but does not remove power to the frequency converter.
Auto On	Puts the system in remote operational mode. <ul style="list-style-type: none"> Responds to an external start command by control terminals or serial communication Speed reference is from an external source
Reset	Resets the frequency converter manually after a fault has been cleared.

4

4.2 Back Up and Copying Parameter Settings

Programming data is stored internally in the frequency converter.

- The data can be up loaded into the LCP memory as a storage back up
- Once stored in the LCP, the data can be downloaded back into the frequency converter
- Or downloaded into other frequency converters by connecting the LCP into those units and downloading the stored settings. (This is a quick way to program multiple units with the same settings.)
- Initialisation of the frequency converter to restore factory default settings does not change data stored in the LCP memory

WARNING

UNINTENDED START!

When frequency converter is connected to AC mains, the motor may start at any time. The frequency converter, motor, and any driven equipment must be in operational readiness. Failure to be in operational readiness when the frequency converter is connected to AC mains could result in death, serious injury, equipment, or property damage.

4.2.1 Uploading Data to the LCP

1. Press [OFF] to stop the motor before uploading or downloading data.
2. Go to *0-50 LCP Copy*.
3. Press [OK].
4. Select *All to LCP*.
5. Press [OK]. A progress bar shows the uploading process.
6. Press [Hand On] or [Auto On] to return to normal operation.

4.2.2 Downloading Data from the LCP

1. Press [OFF] to stop the motor before uploading or downloading data.
2. Go to *0-50 LCP Copy*.
3. Press [OK].
4. Select *All from LCP*.
5. Press [OK]. A progress bar shows the downloading process.
6. Press [Hand On] or [Auto On] to return to normal operation.

4.3 Restoring Default Settings

CAUTION

Initialisation restores the unit to factory default settings. Any programming, motor data, localization, and monitoring records will be lost. Uploading data to the LCP provides a backup prior to initialisation.

Restoring the frequency converter parameter settings back to default values is done by initialisation of the frequency converter. Initialisation can be through *14-22 Operation Mode* or manually.

- Initialisation using *14-22 Operation Mode* does not change frequency converter data such as operating hours, serial communication selections, personal menu settings, fault log, alarm log, and other monitoring functions
- Using *14-22 Operation Mode* is generally recommended
- Manual initialisation erases all motor, programming, localization, and monitoring data and restores factory default settings

4.3.1 Recommended Initialisation

1. Press [Main Menu] twice to access parameters.
2. Scroll to *14-22 Operation Mode*.
3. Press [OK].
4. Scroll to *Initialisation*.
5. Press [OK].
6. Remove power to the unit and wait for the display to turn off.
7. Apply power to the unit.

Default parameter settings are restored during start up. This may take slightly longer than normal.

8. Press [Reset] to return to operation mode.

4.3.2 Manual Initialisation

1. Remove power to the unit and wait for the display to turn off.
2. Press and hold [Status], [Main Menu], and [OK] at the same time and apply power to the unit.

Factory default parameter settings are restored during start up. This may take slightly longer than normal.

Manual initialisation does not reset the following frequency converter information

- *15-00 Operating Hours*
- *15-03 Power Up's*
- *15-04 Over Temp's*
- *15-05 Over Volt's*

5 About Frequency Converter Programming

5.1 Introduction

The frequency converter is programmed for its application functions using parameters. Parameter are accessed by pressing either [Quick Menu] or [Main Menu] on the LCP. (See 4 User Interface for details on using the LCP function keys.) Parameters may also be accessed through a PC using the MCT-10 Setup software (see Remote Programming with MCT-10).

The quick menu is intended for initial start up (Q2-** Quick Set Up) and detailed instructions for common frequency converter applications (Q3-** Function Set Up). Step-by-step instructions are provided. These instructions enable the user to walk through the parameters used for programming applications in their proper sequence. Data entered in a parameter can change the options available in the parameters following that entry. The quick menu presents easy guidelines for getting most systems up and running.

The main menu accesses all parameters and allows for advanced frequency converter applications.

5.2 Programming Example

Here is an example for programming the frequency converter for a common application in open loop using the quick menu.

- This procedure programs the frequency converter to receive a 0-10V DC analog control signal on input terminal 53
- The frequency converter will respond by providing 6-60Hz output to the motor proportional to the input signal (0-10V DC = 6-60Hz)

This is a common HVAC fan application.

Press [Quick Menu] and select the following parameters using the navigation keys to scroll to the titles and press [OK] after each action.

1. Q3 Function Setups

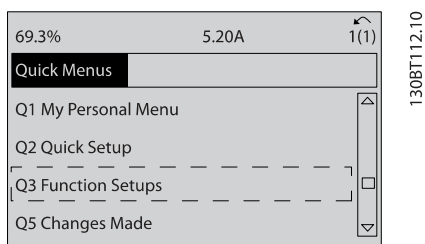

2. Q3-2 Open Loop Settings

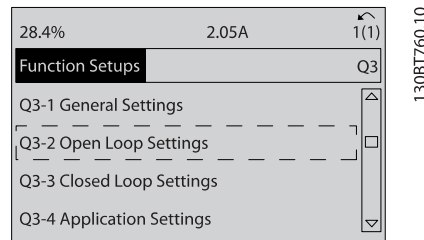

3. Q3-21 Analog Reference

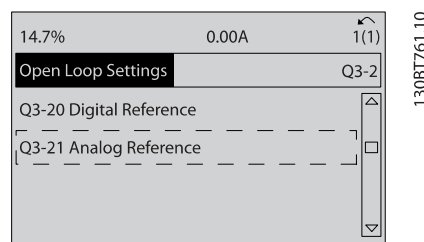

4. 3-02 Minimum Reference. Set minimum internal frequency converter reference to 0Hz. (This sets the minimum frequency converter speed at 0Hz.)

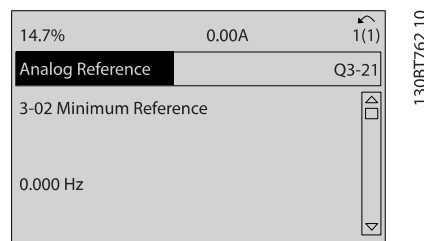

5. 3-03 Maximum Reference. Set maximum internal frequency converter reference to 60Hz. (This sets the maximum frequency converter speed at 60Hz. Note that 50/60Hz is a regional variation.)

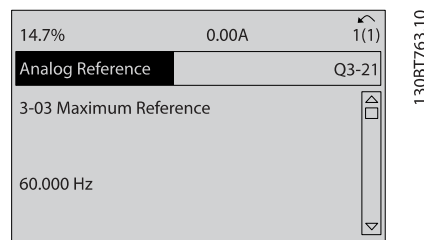

- 6-10 Terminal 53 Low Voltage. Set minimum external voltage reference on Terminal 53 at 0V. (This sets the minimum input signal at 0V.)

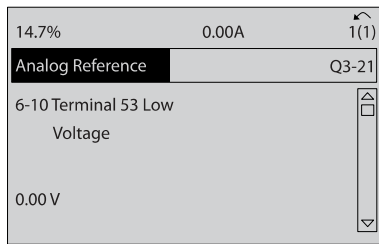

130BT764.10

- 6-11 Terminal 53 High Voltage. Set maximum external voltage reference on Terminal 53 at 10V. (This sets the maximum input signal at 10V.)

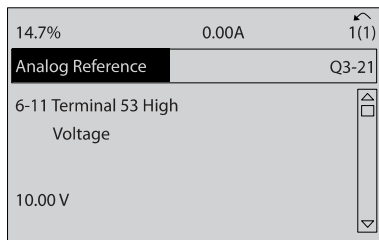

130BT765.10

- 6-14 Terminal 53 Low Ref./Feedb. Value. Set minimum speed reference on Terminal 53 at 6Hz. (This tells the frequency converter that the minimum voltage received on Terminal 53 (0V) equals 6Hz output.)

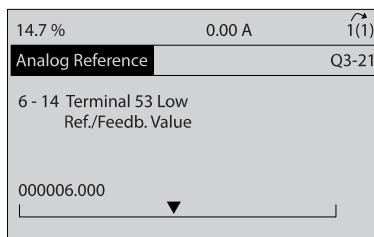

130BT773.10

- 6-15 Terminal 53 High Ref./Feedb. Value. Set maximum speed reference on Terminal 53 at 60Hz. (This tells the frequency converter that the maximum voltage received on Terminal 53 (10V) equals 60Hz output.)

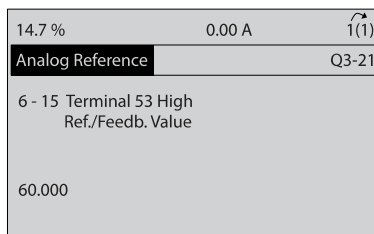

130BT774.10

in the last illustration of the display is at the bottom, indicating the procedure is complete.

Illustration 5.1 shows the wiring connections used to enable this set up.

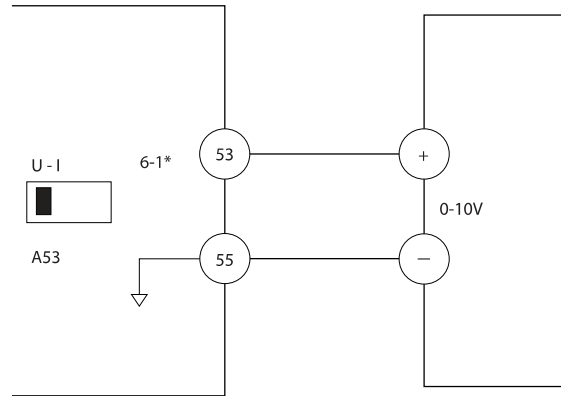

Illustration 5.1 Wiring Example for External Device Providing 0-10V Control Signal

5.3 Control Terminal Programming Examples

Control terminals can be programmed.

- Each terminal has specified functions it is capable of performing
- Parameters associated with the terminal enable the function
- For proper frequency converter functioning, the control terminals must be
 - Wired properly
 - Programmed for the intended function
 - Receiving a signal

See Table 2.3 for control terminal parameter number and default setting. (Default setting can change based on the selection in 0-03 Regional Settings.)

The example below shows accessing Terminal 18 to see the default setting.

With an external device providing a 0-10V control signal connected to frequency converter terminal 53, the system is now ready for operation. Note that the scroll bar on the right

1. Press [Main Menu] twice, scroll to 5-** *Digital In/Out* and press [OK].

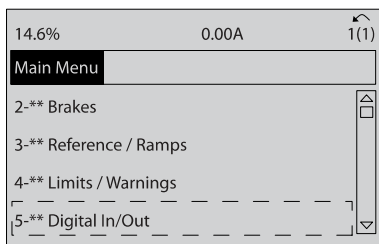

2. Scroll to 5-1* *Digital Inputs* and press [OK].

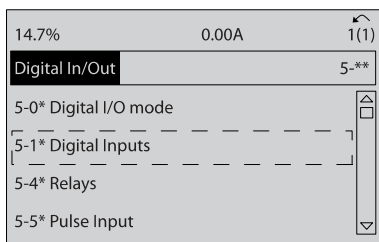

3. Scroll to 5-10 *Terminal 18 Digital Input*. Press [OK] to access function choices. The default setting *Start* is shown.

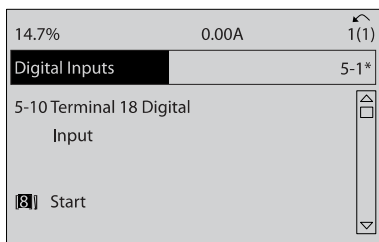

Parameter	International Default Parameter Value	North American Default Parameter Value
3-03 Maximum Reference	50Hz	60Hz
3-04 Reference Function	Sum	External/Preset
4-13 Motor Speed High Limit [RPM] See Note 3	1500RPM	1800RPM
4-14 Motor Speed High Limit [Hz] See Note 4	50Hz	60Hz
4-19 Max Output Frequency	100Hz	120Hz
4-53 Warning Speed High	1500RPM	1800RPM
5-12 Terminal 27 Digital Input	Coast inverse	External interlock
5-40 Function Relay	Alarm	No alarm
6-15 Terminal 53 High Ref./Feedb. Value	50	60
6-50 Terminal 42 Output	Speed 0 - HighLim	Speed 4-20mA
14-20 Reset Mode	Manual reset	Infinite auto reset
22-85 Speed at Design Point [RPM] See Note 3	1500RPM	1800RPM
22-86 Speed at Design Point [Hz]	50Hz	60Hz
24-04 Fire Mode Max Reference	50Hz	60Hz

5

5.4 International/North American Default Parameter Settings

Setting 0-03 *Regional Settings* to [0] *International* or [1] *North America* changes the default settings for some parameters. Table 5.1 lists those parameters that are effected.

Parameter	International Default Parameter Value	North American Default Parameter Value
0-03 Regional Settings	International	North America
0-71 Date Format	DD-MM-YYYY	MM/DD/YYYY
0-72 Time Format	24h	12h
1-20 Motor Power [kW]	See Note 1	See Note 1
1-21 Motor Power [HP]	See Note 2	See Note 2
1-22 Motor Voltage	230V/400V/575V	208V/460V/575V
1-23 Motor Frequency	50Hz	60Hz

Table 5.1 International/North American Default Parameter Settings

Note 1: 1-20 *Motor Power [kW]* is only visible when 0-03 *Regional Settings* is set to [0] *International*.

Note 2: 1-21 *Motor Power [HP]*, is only visible when 0-03 *Regional Settings* is set to [1] *North America*.

Note 3: This parameter is only visible when 0-02 *Motor Speed Unit* is set to [0] *RPM*.

Note 4: This parameter is only visible when 0-02 *Motor Speed Unit* is set to [1] *Hz*.

Changes made to default settings are stored and available for viewing in the quick menu along with any programming entered into parameters.

1. Press [Quick Menu].
2. Scroll to *Q5 Changes Made* and press [OK].

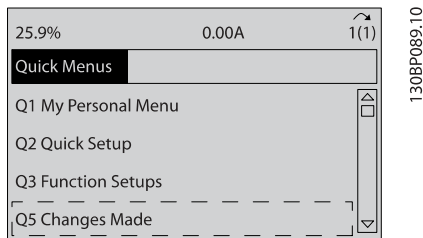

3. Select *Q5-2 Since Factory Setting* to view all programming changes or *Q5-1 Last 10 Changes* for the most recent.

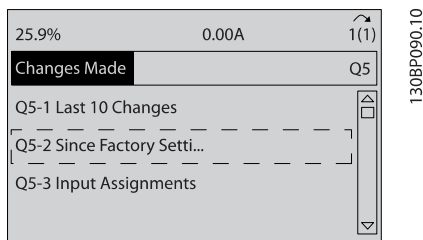
5

5.5 Parameter Menu Structure

Establishing the correct programming for applications often requires setting functions in several related parameters. These parameter settings provide the frequency converter with system details for the frequency converter to operate properly. System details may include such things as input and output signal types, programming terminals, minimum and maximum signal ranges, custom displays, automatic restart, and other features.

- See the LCP display to view detailed parameter programming and setting options
- Press [Info] in any menu location to view additional details for that function
- Press and hold [Main Menu] to enter a parameter number for direct access to that parameter
- Details for common application set ups are provided in *6 Application Set-Up Examples*

5.5.1 Quick Menu Structure

Q3-1 General Settings	0-24 Display Line 3 Large	1-00 Configuration Mode	Q3-31 Single Zone Ext. Set Point	20-70 Closed Loop Type
Q3-10 Adv. Motor Settings	0-37 Display Text 1	20-12 Reference/Feedback Unit	1-00 Configuration Mode	20-71 PID Performance
1-90 Motor Thermal Protection	0-38 Display Text 2	20-13 Minimum Reference/Feedb.	20-12 Reference/Feedback Unit	20-72 PID Output Change
1-93 Thermistor Source	0-39 Display Text 3	20-14 Maximum Reference/Feedb.	20-13 Minimum Reference/Feedb.	20-73 Minimum Feedback Level
1-29 Automatic Motor Adaptation (AMA)	Q3-2 Open Loop Settings	6-22 Terminal 54 Low Current	20-14 Maximum Reference/Feedb.	20-74 Maximum Feedback Level
14-01 Switching Frequency	Q3-20 Digital Reference	6-24 Terminal 54 Low Ref./Feedb. Value	6-10 Terminal 53 Low Voltage	20-79 PID Autotuning
4-53 Warning Speed High	3-02 Minimum Reference	6-25 Terminal 54 High Ref./Feedb. Value	6-11 Terminal 53 High Voltage	Q3-32 Multi Zone / Adv
Q3-11 Analog Output	3-03 Maximum Reference	6-26 Terminal 54 Filter Time Constant	6-12 Terminal 53 Low Current	1-00 Configuration Mode
6-50 Terminal 42 Output	3-10 Preset Reference	6-27 Terminal 54 Live Zero	6-13 Terminal 53 High Current	3-15 Reference 1 Source
6-51 Terminal 42 Output Min Scale	5-13 Terminal 29 Digital Input	6-00 Live Zero Timeout Time	6-14 Terminal 53 Low Ref./Feedb. Value	3-16 Reference 2 Source
6-52 Terminal 42 Output Max Scale	5-14 Terminal 32 Digital Input	6-01 Live Zero Timeout Function	6-15 Terminal 53 High Ref./Feedb. Value	20-00 Feedback 1 Source
Q3-12 Clock Settings	5-15 Terminal 33 Digital Input	20-21 Setpoint 1	6-22 Terminal 54 Low Current	20-01 Feedback 1 Conversion
0-70 Date and Time	Q3-21 Analog Reference	20-81 PID Normal/ Inverse Control	6-24 Terminal 54 Low Ref./Feedb. Value	20-02 Feedback 1 Source Unit
0-71 Date Format	3-02 Minimum Reference	20-82 PID Start Speed [RPM]	6-25 Terminal 54 High Ref./Feedb. Value	20-03 Feedback 2 Source
0-72 Time Format	3-03 Maximum Reference	20-83 PID Start Speed [Hz]	6-26 Terminal 54 Filter Time Constant	20-04 Feedback 2 Conversion
0-74 DST/Summertime	6-10 Terminal 53 Low Voltage	20-93 PID Proportional Gain	6-27 Terminal 54 Live Zero	20-05 Feedback 2 Source Unit
0-76 DST/Summertime Start	6-11 Terminal 53 High Voltage	20-94 PID Integral Time	6-00 Live Zero Timeout Time	20-06 Feedback 3 Source
0-77 DST/Summertime End	6-12 Terminal 53 Low Current	20-70 Closed Loop Type	6-01 Live Zero Timeout Function	20-07 Feedback 3 Conversion
Q3-13 Display Settings	6-13 Terminal 53 High Current	20-71 PID Performance	20-81 PID Normal/ Inverse Control	20-08 Feedback 3 Source Unit
0-20 Display Line 1.1 Small	6-14 Terminal 53 Low Ref./Feedb. Value	20-72 PID Output Change	20-82 PID Start Speed [RPM]	20-12 Reference/Feedback Unit
0-21 Display Line 1.2 Small	6-15 Terminal 53 High Ref./Feedb. Value	20-73 Minimum Feedback Level	20-83 PID Start Speed [Hz]	20-13 Minimum Reference/Feedb.
0-22 Display Line 1.3 Small	Q3-3 Closed Loop Settings	20-74 Maximum Feedback Level	20-93 PID Proportional Gain	20-14 Maximum Reference/Feedb.
0-23 Display Line 2 Large	Q3-30 Single Zone Int. Set Point	20-79 PID Autotuning	20-94 PID Integral Time	6-10 Terminal 53 Low Voltage

6-11 Terminal 53 High Voltage	20-21 Setpoint 1	22-22 Low Speed Detection	22-21 Low Power Detection	22-87 Pressure at No-Flow Speed
6-12 Terminal 53 Low Current	20-22 Setpoint 2	22-23 No-Flow Function	22-22 Low Speed Detection	22-88 Pressure at Rated Speed
6-13 Terminal 53 High Current	20-81 PID Normal/ Inverse Control	22-24 No-Flow Delay	22-23 No-Flow Function	22-89 Flow at Design Point
6-14 Terminal 53 Low Ref./Feedb. Value	20-82 PID Start Speed [RPM]	22-40 Minimum Run Time	22-24 No-Flow Delay	22-90 Flow at Rated Speed
6-15 Terminal 53 High Ref./Feedb. Value	20-83 PID Start Speed [Hz]	22-41 Minimum Sleep Time	22-40 Minimum Run Time	1-03 Torque Characteristics
6-16 Terminal 53 Filter Time Constant	20-93 PID Proportional Gain	22-42 Wake-up Speed [RPM]	22-41 Minimum Sleep Time	1-73 Flying Start
6-17 Terminal 53 Live Zero	20-94 PID Integral Time	22-43 Wake-up Speed [Hz]	22-42 Wake-up Speed [RPM]	Q3-42 Compressor Functions
6-20 Terminal 54 Low Voltage	20-70 Closed Loop Type	22-44 Wake-up Ref./FB Difference	22-43 Wake-up Speed [Hz]	1-03 Torque Characteristics
6-21 Terminal 54 High Voltage	20-71 PID Performance	22-45 Setpoint Boost	22-44 Wake-up Ref./FB Difference	1-71 Start Delay
6-22 Terminal 54 Low Current	20-72 PID Output Change	22-46 Maximum Boost Time	22-45 Setpoint Boost	22-75 Short Cycle Protection
6-23 Terminal 54 High Current	20-73 Minimum Feedback Level	2-10 Brake Function	22-46 Maximum Boost Time	22-76 Interval between Starts
6-24 Terminal 54 Low Ref./Feedb. Value	20-74 Maximum Feedback Level	2-16 AC brake Max. Current	22-26 Dry Pump Function	22-77 Minimum Run Time
6-25 Terminal 54 High Ref./Feedb. Value	20-79 PID Autotuning	2-17 Over-voltage Control	22-27 Dry Pump Delay	5-01 Terminal 27 Mode
6-26 Terminal 54 Filter Time Constant	Q3-4 Application Settings	1-73 Flying Start	22-80 Flow Compensation	5-02 Terminal 29 Mode
6-27 Terminal 54 Live Zero	Q3-40 Fan Functions	1-71 Start Delay	22-81 Square-linear Curve Approximation	5-12 Terminal 27 Digital Input
6-00 Live Zero Timeout Time	22-60 Broken Belt Function	1-80 Function at Stop	22-82 Work Point Calculation	5-13 Terminal 29 Digital Input
6-01 Live Zero Timeout Function	22-61 Broken Belt Torque	2-00 DC Hold/Preheat Current	22-83 Speed at No-Flow [RPM]	5-40 Function Relay
4-56 Warning Feedback Low	22-62 Broken Belt Delay	4-10 Motor Speed Direction	22-84 Speed at No-Flow [Hz]	1-73 Flying Start
4-57 Warning Feedback High	4-64 Semi-Auto Bypass Set-up	Q3-41 Pump Functions	22-85 Speed at Design Point [RPM]	1-86 Trip Speed Low [RPM]
20-20 Feedback Function	1-03 Torque Characteristics	22-20 Low Power Auto Set-up	22-86 Speed at Design Point [Hz]	1-87 Trip Speed Low [Hz]

5.5.2 Main Menu Structure

0-0** Operation / Display	0-37 Display Text 1	0-77 DST/Summertime End	1-36 Iron Loss Resistance (Rfe)	1-82 Min Speed for Function at Stop [Hz]
0-0* Basic Settings	0-38 Display Text 2	0-79 Clock Fault	1-39 Motor Poles	1-86 Trip Speed Low [RPM]
0-01 Language	0-39 Display Text 3	0-81 Working Days	1-5* Load Indep. Setting	1-87 Trip Speed Low [Hz]
0-02 Motor Speed Unit	0-4* LCP Keypad	0-82 Additional Working Days	1-50 Motor Magnetisation at Zero Speed	1-9* Motor Temperature
0-03 Regional Settings	0-40 [Hand on] Key on LCP	0-83 Additional Non-Working Days	1-51 Min Speed Normal Magnetising [RPM]	1-90 Motor Thermal Protection
0-04 Operating State at Power-up	0-41 [Off] Key on LCP	0-89 Date and Time Readout	1-52 Min Speed Normal Magnetising [Hz]	1-91 Motor External Fan
0-05 Local Mode Unit	0-42 [Auto on] Key on LCP	1-1** Load and Motor	1-58 Flystart Test Pulses Current	1-93 Thermistor Source
0-1* Set-up Operations	0-43 [Reset] Key on LCP	1-0* General Settings	1-59 Flystart Test Pulses Frequency	2-1** Brakes
0-10 Active Set-up	0-44 [Off/Reset] Key on LCP	1-00 Configuration Mode	1-6* Load Deplen. Setting	2-0* DC-Brake
0-11 Programming Set-up	0-45 [Drive Bypass] Key on LCP	1-03 Torque Characteristics	1-60 Low Speed Load Compensation	2-00 DC Hold/Preheat Current
0-12 This Set-up Linked to	0-5* Copy/Save	1-06 Clockwise Direction	1-61 High Speed Load Compensation	2-01 DC Brake Current
0-13 Readout: Linked Set-ups	0-50 LCP Copy	1-2* Motor Data	1-62 Slip Compensation	2-02 DC Braking Time
0-14 Readout: Prog. Set-ups / Channel	0-51 Set-up Copy	1-20 Motor Power [kW]	1-63 Slip Compensation Time Constant	2-03 DC Brake Cut In Speed [RPM]
0-2* LCP Display	0-6* Password	1-21 Motor Power [HP]	1-64 Resonance Dampening	2-04 DC Brake Cut In Speed [Hz]
0-20 Display Line 1.1 Small	0-60 Main Menu Password	1-22 Motor Voltage	1-65 Resonance Dampening Time Constant	2-1* Brake Energy Funct.
0-21 Display Line 1.2 Small	0-61 Access to Main Menu w/o Password	1-23 Motor Frequency	1-7* Start Adjustments	2-10 Brake Function
0-22 Display Line 1.3 Small	0-65 Personal Menu Password	1-24 Motor Current	1-71 Start Delay	2-11 Brake Resistor (ohm)
0-23 Display Line 2 Large	0-66 Access to Personal Menu w/o Password	1-25 Motor Nominal Speed	1-73 Flying Start	2-12 Brake Power Limit (kW)
0-24 Display Line 3 Large	0-7* Clock Settings	1-28 Motor Rotation Check	1-77 Compressor Start Max Speed [RPM]	2-13 Brake Power Monitoring
0-25 My Personal Menu	0-70 Date and Time	1-29 Automatic Motor Adaptation (AMA)	1-78 Compressor Start Max Speed [Hz]	2-15 Brake Check
0-3* LCP Custom Readout	0-71 Date Format	1-3* Adv. Motor Data	1-79 Compressor Start Max Time to Trip	2-16 AC brake Max. Current
0-30 Custom Readout Unit	0-72 Time Format	1-30 Stator Resistance (Rs)	1-8* Stop Adjustments	2-17 Over-voltage Control
0-31 Custom Readout Min Value	0-74 DST/Summertime	1-31 Rotor Resistance (Rr)	1-80 Function at Stop	3-1** Reference / Ramps
0-32 Custom Readout Max Value	0-76 DST/Summertime Start	1-35 Main Reactance (Xh)	1-81 Min Speed for Function at Stop [RPM]	3-0* Reference Limits

3-02 Minimum Reference	3-92 Power Restore	4-6* Speed Bypass	5-33 Term X30/7 Digi Out (MCB 101)	5-93 Pulse Out #27 Bus Control
3-03 Maximum Reference	3-93 Maximum Limit	4-60 Bypass Speed From [RPM]	5-4* Relays	5-94 Pulse Out #27 Timeout Preset
3-04 Reference Function	3-94 Minimum Limit	4-61 Bypass Speed From [Hz]	5-40 Function Relay	5-95 Pulse Out #29 Bus Control
3-1* References	3-95 Ramp Delay	4-62 Bypass Speed To [RPM]	5-41 On Delay, Relay	5-96 Pulse Out #29 Timeout Preset
3-10 Preset Reference	4-** Limits / Warnings	4-63 Bypass Speed To [Hz]	5-42 Off Delay, Relay	5-97 Pulse Out #X30/6 Bus Control
3-11 Jog Speed [Hz]	4-1* Motor Limits	4-64 Semi-Auto Bypass Set-up	5-5* Pulse Input	5-98 Pulse Out #X30/6 Timeout Preset
3-13 Reference Site	4-10 Motor Speed Direction	5-** Digital In/Out	5-50 Term. 29 Low Frequency	6-** Analog In/Out
3-14 Preset Relative Reference	4-11 Motor Speed Low Limit [RPM]	5-0* Digital I/O mode	5-51 Term. 29 High Frequency	6-0* Analog I/O Mode
3-15 Reference 1 Source	4-12 Motor Speed Low Limit [Hz]	5-00 Digital I/O Mode	5-52 Term. 29 Low Ref./Feedb. Value	6-00 Live Zero Timeout Time
3-16 Reference 2 Source	4-13 Motor Speed High Limit [RPM]	5-01 Terminal 27 Mode	5-53 Term. 29 High Ref./Feedb. Value	6-01 Live Zero Timeout Function
3-17 Reference 3 Source	4-14 Motor Speed High Limit [Hz]	5-02 Terminal 29 Mode	5-54 Pulse Filter Time Constant #29	6-02 Fire Mode Live Zero Timeout Function
3-19 Jog Speed [RPM]	4-16 Torque Limit Motor Mode	5-1* Digital Inputs	5-55 Term. 33 Low Frequency	6-1* Analog Input 53
3-4* Ramp 1	4-17 Torque Limit Generator Mode	5-10 Terminal 18 Digital Input	5-56 Term. 33 High Frequency	6-10 Terminal 53 Low Voltage
3-41 Ramp 1 Ramp Up Time	4-18 <i>Current Limit</i>	5-11 Terminal 19 Digital Input	5-57 Term. 33 Low Ref./Feedb. Value	6-11 Terminal 53 High Voltage
3-42 Ramp 1 Ramp Down Time	4-19 Max Output Frequency	5-12 Terminal 27 Digital Input	5-58 Term. 33 High Ref./Feedb. Value	6-12 Terminal 53 Low Current
3-5* Ramp 2	4-5* Adj. Warnings	5-13 Terminal 29 Digital Input	5-59 Pulse Filter Time Constant #33	6-13 Terminal 53 High Current
3-51 Ramp 2 Ramp Up Time	4-50 Warning Current Low	5-14 Terminal 32 Digital Input	5-6* Pulse Output	6-14 Terminal 53 Low Ref./Feedb. Value
3-52 Ramp 2 Ramp Down Time	4-51 Warning Current High	5-15 Terminal 33 Digital Input	5-60 Terminal 27 Pulse Output	6-15 Terminal 53 High Ref./Feedb. Value
3-8* Other Ramps	4-52 Warning Speed Low	5-16 Terminal X30/2 Digital Input	Variable	6-16 Terminal 53 Filter Time Constant
3-80 Jog Ramp Time	4-53 Warning Speed High	5-17 Terminal X30/3 Digital Input	5-62 Pulse Output Max Freq #27	6-17 Terminal 53 Live Zero
3-81 Quick Stop Ramp Time	4-54 Warning Reference Low	5-18 Terminal X30/4 Digital Input	5-63 Terminal 29 Pulse Output	6-2* Analog Input 54
3-82 Starting Ramp Up Time	4-55 Warning Reference High	5-3* Digital Outputs	Variable	6-20 Terminal 54 Low Voltage
3-9* Digital Pot.Meter	4-56 Warning Feedback Low	5-30 Terminal 27 Digital Output	5-65 Pulse Output Max Freq #29	6-21 Terminal 54 High Voltage
3-90 Step Size	4-57 Warning Feedback High	5-31 Terminal 29 Digital Output	5-66 Terminal X30/6 Pulse Output	6-22 Terminal 54 Low Current
3-91 Ramp Time	4-58 Missing Motor Phase Function	5-32 Term X30/6 Digi Out (MCB 101)	Variable	6-23 Terminal 54 High Current

6-24 Terminal 54 Low Ref./Feedb. Value	6-64 Terminal X30/8 Output Timeout Preset	8-52 DC Brake Select	9-16 PCD Read Configuration	10-** CAN Fieldbus
6-25 Terminal 54 High Ref./Feedb. Value	8-** Comm. and Options	8-53 Start Select	9-18 Node Address	10-0* Common Settings
6-26 Terminal 54 Filter Time Constant	8-0* General Settings	8-54 Reversing Select	9-22 Telegram Selection	10-00 CAN Protocol
6-27 Terminal 54 Live Zero	8-01 Control Site	8-55 Set-up Select	9-23 Parameters for Signals	10-01 Baud Rate Select
6-3* Analog Input X30/11	8-02 Control Source	8-56 Preset Reference Select	9-27 Parameter Edit	10-02 MAC ID
6-30 Terminal X30/11 Low Voltage	8-03 Control Timeout Time	8-7* BACnet	9-28 Process Control	10-05 Readout Transmit Error Counter
6-31 Terminal X30/11 High Voltage	8-04 Control Timeout Function	8-70 BACnet Device Instance	9-44 Fault Message Counter	10-06 Readout Receive Error Counter
6-34 Term. X30/11 Low Ref./Feedb. Value	8-05 End-of-Timeout Function	8-72 MS/TP Max Masters	9-45 Fault Code	10-07 Readout Bus Off Counter
6-35 Term. X30/11 High Ref./Feedb. Value	8-06 Reset Control Timeout	8-73 MS/TP Max Info Frames	9-47 Fault Number	10-1* DeviceNet
6-36 Term. X30/11 Filter Time Constant	8-07 Diagnosis Trigger	8-74 "I-Am" Service	9-52 Fault Situation Counter	10-10 Process Data Type Selection
6-37 Term. X30/11 Live Zero	8-08 Readout Filtering	8-75 Initialisation Password	9-53 Profibus Warning Word	10-11 Process Data Config Write
6-4* Analog Input X30/12	8-1* Control Settings	8-8* FC Port Diagnostics	9-63 Actual Baud Rate	10-12 Process Data Config Read
6-40 Terminal X30/12 Low Voltage	8-10 Control Profile	8-80 Bus Message Count	9-64 Device Identification	10-13 Warning Parameter
6-41 Terminal X30/12 High Voltage	8-13 Configurable Status Word STW	8-81 Bus Error Count	9-65 Profile Number	10-14 Net Reference
6-44 Term. X30/12 Low Ref./Feedb. Value	8-3* FC Port Settings	8-82 Slave Messages Rcvd	9-67 Control Word 1	10-15 Net Control
6-45 Term. X30/12 High Ref./Feedb. Value	8-30 Protocol	8-83 Slave Error Count	9-68 Status Word 1	10-2* COS Filters
6-46 Term. X30/12 Filter Time Constant	8-31 Address	8-84 Slave Messages Sent	9-70 Programming Set-up	10-20 COS Filter 1
6-47 Term. X30/12 Live Zero	8-32 Baud Rate	8-85 Slave Timeout Errors	9-71 Profibus Save Data Values	10-21 COS Filter 2
6-5* Analog Output 42	8-33 Parity / Stop Bits	8-89 Diagnostics Count	9-72 ProfibusDriveReset	10-22 COS Filter 3
6-50 Terminal 42 Output	8-34 Estimated cycle time	8-9* Bus Jog / Feedback	9-80 Defined Parameters (1)	10-23 COS Filter 4
6-51 Terminal 42 Output Min Scale	8-35 Minimum Response Delay	8-90 Bus Jog 1 Speed	9-81 Defined Parameters (2)	10-3* Parameter Access
6-52 Terminal 42 Output Max Scale	8-36 Maximum Response Delay	8-91 Bus Jog 2 Speed	9-82 Defined Parameters (3)	10-30 Array Index
6-53 Terminal 42 Output Bus Control	8-37 Maximum Inter-Char Delay	8-94 Bus Feedback 1	9-83 Defined Parameters (4)	10-31 Store Data Values
6-54 Terminal 42 Output Timeout Preset	8-4* FC MC protocol set	8-95 Bus Feedback 2	9-84 Defined Parameters (5)	10-32 Devicenet Revision
6-6* Analog Output X30/8	8-40 Telegram Selection	8-96 Bus Feedback 3	9-90 Changed Parameters (1)	10-33 Store Always
6-60 Terminal X30/8 Output	8-42 PCD write configuration	9-** Profibus	9-91 Changed Parameters (2)	10-34 DeviceNet Product Code
6-61 Terminal X30/8 Min. Scale	8-43 PCD read configuration	9-00 Setpoint	9-92 Changed Parameters (3)	10-39 Devicenet F Parameters
6-62 Terminal X30/8 Max. Scale	8-5* Digital/Bus	9-07 Actual Value	9-93 Changed Parameters (4)	11-** LonWorks
6-63 Terminal X30/8 Output Bus Control	8-50 Coasting Select	9-15 PCD Write Configuration	9-94 Changed Parameters (5)	11-0* LonWorks ID

11-00 Neuron ID			14-50 RFI Filter	15-23 Historic Log: Date and Time	15-72 Option in Slot B
11-1* LON Functions	14-** Special Functions				
11-10 Drive Profile	14-0* Inverter Switching		14-51 DC Link Compensation	15-3* Alarm Log	15-73 Slot B Option SW Version
11-15 LON Warning Word	14-00 Switching Pattern		14-52 Fan Control	15-30 Alarm Log: Error Code	15-74 Option in Slot C0
11-17 XIF Revision	14-01 Switching Frequency		14-53 Fan Monitor	15-31 Alarm Log: Value	15-75 Slot C0 Option SW Version
	14-03 Overmodulation		14-6* Auto Derate	15-32 Alarm Log: Time	15-76 Option in Slot C1
11-18 LonWorks Revision	14-04 PWM Random		14-60 Function at Over Temperature	15-33 Alarm Log: Date and Time	15-77 Slot C1 Option SW Version
11-2* LON Param. Access	14-1* Mains On/Off		14-61 Function at Inverter Overload	15-4* Drive Identification	15-9* Parameter Info
11-21 Store Data Values	14-10 Mains Failure		14-62 Inv. Overload Derate Current	15-40 FC Type	15-92 Defined Parameters
13-** Smart Logic	14-11 Mains Voltage at Mains Fault		15-** Drive Information	15-41 Power Section	15-93 Modified Parameters
13-0* SLC Settings	14-12 Function at Mains Imbalance		15-0* Operating Data	15-42 Voltage	15-98 Drive Identification
13-00 SL Controller Mode	14-2* Reset Functions		15-00 Operating Hours	15-43 Software Version	15-99 Parameter Metadata
13-01 Start Event	14-20 Reset Mode		15-01 Running Hours	15-44 Ordered Typecode String	16-** Data Readouts
13-02 Stop Event	14-21 Automatic Restart Time		15-02 kWh Counter	15-45 Actual Typecode String	16-0* General Status
13-03 Reset SLC	14-22 Operation Mode		15-03 Power Up's	15-46 Frequency Converter Ordering No	16-00 Control Word
13-1* Comparators	14-23 Typecode Setting		15-04 Over Temp's	15-47 Power Card Ordering No	16-01 Reference [Unit]
13-10 Comparator Operand	14-25 Trip Delay at Torque Limit		15-05 Over Volt's	15-48 LCP Id No	16-02 Reference [%]
13-11 Comparator Operator	14-26 Trip Delay at Inverter Fault		15-06 Reset kWh Counter	15-49 SW ID Control Card	16-03 Status Word
13-12 Comparator Value	14-28 Production Settings		15-07 Running Hours Counter	15-50 SW ID Power Card	16-05 Main Actual Value [%]
13-2* Timers	14-29 Service Code		15-08 Number of Starts	15-51 Frequency Converter Serial Number	16-09 Custom Readout
13-20 SL Controller Timer	14-3* Current Limit Ctrl.		15-1* Log Settings	15-53 Power Card Serial Number	16-1* Motor Status
13-4* Logic Rules	14-30 Current Lim Ctrl, Proportional Gain		15-10 Logging Source	15-55 Vendor URL	16-10 Power [kW]
13-40 Logic Rule Boolean 1	14-31 Current Lim Ctrl, Integration Time		15-11 Logging Interval	15-56 Vendor Name	16-11 Power [hp]
13-41 Logic Rule Operator 1	14-32 Current Lim Ctrl, Filter Time		15-12 Trigger Event	15-6* Option Ident	16-12 Motor Voltage
13-42 Logic Rule Boolean 2	14-4* Energy Optimising		15-13 Logging Mode	15-60 Option Mounted	16-13 Frequency
13-43 Logic Rule Operator 2	14-40 VT Level		15-14 Samples Before Trigger	15-61 Option SW Version	16-14 Motor Current
13-44 Logic Rule Boolean 3	14-41 AEO Minimum Magnetisation		15-2* Historic Log	15-62 Option Ordering No	16-15 Frequency [%]
13-5* States	14-42 Minimum AEO Frequency		15-20 Historic Log: Event	15-63 Option Serial No	16-16 [Nm]
13-51 SL Controller Event	14-43 Motor Cosphi		15-21 Historic Log: Value	15-70 Option in Slot A	16-17 Speed [RPM]
13-52 SL Controller Action	14-5* Environment		15-22 Historic Log: Time	15-71 Slot A Option SW Version	16-18 Motor Thermal

16-22 Torque [%]	16-66 Digital Output [bin]	18-1* Fire Mode Log	20-14 Maximum Reference/ Feedb.	20-84 On Reference Bandwidth
16-26 Power Filtered [kW]	16-67 Pulse Input #29 [Hz]	18-10 Fire Mode Log: Event	20-2* Feedback/Setpoint	20-9* PID Controller
16-27 Power Filtered [hp]	16-68 Pulse Input #33 [Hz]	18-11 Fire Mode Log: Time	20-20 Feedback Function	20-91 PID Anti Windup
16-3* Drive Status	16-69 Pulse Output #27 [Hz]	18-12 Fire Mode Log: Date and Time	20-21 Setpoint 1	20-93 PID Proportional Gain
16-30 DC Link Voltage	16-70 Pulse Output #29 [Hz]	18-3* Inputs & Outputs	20-22 Setpoint 2	20-94 PID Integral Time
16-32 Brake Energy /s	16-71 Relay Output [bin]	18-30 Analog Input X42/1	20-23 Setpoint 3	20-95 PID Differentiation Time
16-33 Brake Energy /2 min	16-72 Counter A	18-31 Analog Input X42/3	20-3* Feedb. Adv. Conv.	20-96 PID Diff. Gain Limit
16-34 Heatsink Temp.	16-73 Counter B	18-32 Analog Input X42/5	20-30 Refrigerant	21-** Ext. Closed Loop
16-36 Nom. Current	16-75 Analog In X30/11	18-33 Analog Out X42/7 [V]	20-31 User Defined	21-0* Ext. CL Autotuning
16-37 Inv. Max. Current	16-76 Analog In X30/12	18-34 Analog Out X42/9 [V]	Refrigerant A1	21-00 Closed Loop Type
16-38 SL Controller State	16-77 Analog Out X30/8 [mA]	18-35 Analog Out X42/11 [V]	20-32 User Defined	21-01 PID Performance
16-39 Control Card Temp.	16-8* Fieldbus & FC Port	18-36 Analog Input X48/2 [mA]	Refrigerant A3	21-02 PID Output Change
16-40 Logging Buffer Full	16-80 Fieldbus CTW 1	18-37 Temp. Input X48/4	20-34 Duct 1 Area [m2]	21-03 Minimum Feedback Level
16-43 Timed Actions Status	16-82 Fieldbus REF 1	18-38 Temp. Input X48/7	20-35 Duct 1 Area [in2]	21-04 Maximum Feedback Level
16-49 Current Fault Source	16-84 Comm. Option STW	18-39 Temp. Input X48/10	20-36 Duct 2 Area [m2]	21-09 PID Autotuning
16-5* Ref. & Feedb.	16-85 FC Port CTW 1	18-5* Ref. & Feedb.	20-37 Duct 2 Area [in2]	21-1* Ext. CL 1 Ref./Fb.
16-50 External Reference	16-86 FC Port REF 1	18-50 Sensorless Readout [unit]	20-38 Air Density Factor [%]	21-10 Ext. 1 Ref./Feedback Unit
16-52 Feedback [Unit]	16-9* Diagnosis Readouts	20-** Drive Closed Loop	20-6* Sensorless	21-11 Ext. 1 Minimum Reference
16-53 Digi. Pot Reference	16-90 Alarm Word	20-0* Feedback	20-60 Sensorless Unit	21-12 Ext. 1 Maximum Reference
16-54 Feedback 1 [Unit]	16-91 Alarm Word 2	20-00 1 Source	20-69 Sensorless Information	21-13 Ext. 1 Reference Source
16-55 Feedback 2 [Unit]	16-92 Warning Word	20-01 Feedback 1 Conversion	20-7* PID Autotuning	21-14 Ext. 1 Feedback Source
16-56 3 [Unit]	16-93 Warning Word 2	20-02 Feedback 1 Source Unit	20-70 Closed Loop Type	21-15 Ext. 1 Setpoint
16-58 PID Output [%]	16-94 Ext. Status Word	20-03 Feedback 2 Source	20-71 PID Performance	21-17 Ext. 1 Reference [Unit]
16-6* Inputs & Outputs	16-96 Maintenance Word	20-04 Feedback 2 Conversion	20-72 PID Output Change	21-18 Ext. 1 Feedback [Unit]
16-60 Digital Input	18-** Info & Readouts	20-05 Feedback 2 Source Unit	20-73 Minimum Feedback Level	21-19 Ext. 1 Output [%]
16-61 Terminal 53 Switch Setting	18-0* Maintenance Log	20-06 Feedback 3 Source	20-74 Maximum Feedback Level	21-2* Ext. CL 1 PID
16-62 Analog Input 53	18-00 Maintenance Log: Item	20-07 Feedback 3 Conversion	20-79 PID Autotuning	21-20 Ext. 1 Normal/Inverse Control
16-63 Terminal 54 Switch Setting	18-01 Maintenance Log: Action	20-08 Feedback 3 Source Unit	20-8* PID Basic Settings	21-21 Ext. 1 Proportional Gain
16-64 Input 54	18-02 Maintenance Log: Time	20-12 Reference/Feedback Unit	20-81 PID Normal/ Inverse Control	21-22 Ext. 1 Integral Time
16-65 Analog Output 42 [mA]	18-03 Maintenance Log: Date and Time	20-13 Minimum Reference/Feedb.	20-82 PID Start Speed [RPM]	21-23 Ext. 1 Differentiation Time

21-24 Ext. 1 Dif. Gain Limit	21-60 Ext. 3 Normal/Inverse Control	22-4* Sleep Mode	22-86 Speed at Design Point [Hz]	23-60 Trend Variable
21-3* Ext. CL 2 Ref/Fb.	21-61 Ext. 3 Proportional Gain	22-40 Minimum Run Time	22-87 Pressure at No-Flow Speed	23-61 Continuous Bin Data
21-30 Ext. 2 Ref./Feedback Unit	21-62 Ext. 3 Integral Time	22-41 Minimum Sleep Time	22-88 Pressure at Rated Speed	23-62 Timed Bin Data
21-31 Ext. 2 Minimum Reference	21-63 Ext. 3 Differentiation Time	22-42 Wake-up Speed [RPM]	22-89 Flow at Design Point	23-63 Timed Period Start
21-32 Ext. 2 Maximum Reference	21-64 Ext. 3 Dif. Gain Limit	22-43 Wake-up Speed [Hz]	22-90 Flow at Rated Speed	23-64 Timed Period Stop
21-33 Ext. 2 Reference Source	22-** Appl. Functions	22-44 Wake-up Ref./FB Difference	23-** Time-based Functions	23-65 Minimum Bin Value
21-34 Ext. 2 Feedback Source	22-0* Miscellaneous	22-45 Setpoint Boost	23-0* Timed Actions	23-66 Reset Continuous Bin Data
21-35 Ext. 2 Setpoint	22-00 External Interlock Delay	22-46 Maximum Boost Time	23-00 ON Time	23-67 Reset Timed Bin Data
21-37 Ext. 2 Reference [Unit]	22-01 Power Filter Time	22-5* End of Curve	23-01 ON Action	23-8* Payback Counter
21-38 Ext. 2 Feedback [Unit]	22-2* No-Flow Detection	22-50 End of Curve Function	23-02 OFF Time	23-80 Power Reference Factor
21-39 Ext. 2 Output [%]	22-20 Low Power Auto Set-up	22-51 End of Curve Delay	23-03 OFF Action	23-81 Energy Cost
21-4* Ext. CL 2 PID	22-21 Low Power Detection	22-6* Broken Belt Detection	23-04 Occurrence	23-82 Investment
21-40 Ext. 2 Normal/Inverse Control	22-22 Low Speed Detection	22-60 Broken Belt Function	23-08 Timed Actions Mode	23-83 Energy Savings
21-41 Ext. 2 Proportional Gain	22-23 No-Flow Function	22-61 Broken Belt Torque	23-09 Timed Actions Reac-tion	23-84 Cost Savings
21-42 Ext. 2 Integral Time	22-24 No-Flow Delay	22-62 Broken Belt Delay	23-1* Maintenance	24-** Appl. Functions 2
21-43 Ext. 2 Differentiation Time	22-26 Dry Pump Function	22-7* Short Cycle Protection	23-10 Maintenance Item	24-0* Fire Mode
21-44 Ext. 2 Dif. Gain Limit	22-27 Dry Pump Delay	22-75 Short Cycle Protection	23-11 Maintenance Action	24-00 Fire Mode Function
21-5* Ext. CL 3 Ref/Fb.	22-3* No-Flow Power Tuning	22-76 Interval between Starts	23-12 Maintenance Time Base	24-01 Fire Mode Configuration
21-50 Ext. 3 Ref./Feedback Unit	22-30 No-Flow Power	22-77 Minimum Run Time	23-13 Maintenance Time Interval	24-02 Fire Mode Unit
21-51 Ext. 3 Minimum Reference	22-31 Power Correction Factor	22-78 Minimum Run Time Override	23-14 Maintenance Date and Time	24-03 Fire Mode Min Reference
21-52 Ext. 3 Maximum Reference	22-32 Low Speed [RPM]	22-79 Minimum Run Time Override Value	23-15 Reset Maintenance Word	24-04 Fire Mode Max Reference
21-53 Ext. 3 Reference Source	22-33 Low Speed [Hz]	22-8* Flow Compensation	23-16 Maintenance Text	24-05 Fire Mode Preset Reference
21-54 Ext. 3 Feedback Source	22-34 Low Speed Power [kW]	22-80 Flow Compensation	23-5* Energy Log	24-06 Fire Mode Reference Source
21-55 Ext. 3 Setpoint	22-35 Low Speed Power [HP]	22-81 Square-linear Curve Approx-imation	23-50 Energy Log Resolution	24-07 Fire Mode Feedback Source
21-57 Ext. 3 Reference [Unit]	22-36 High Speed [RPM]	22-82 Work Point Calculation	23-51 Period Start	24-09 Fire Mode Alarm Handling
21-58 Ext. 3 Feedback [Unit]	22-37 High Speed [Hz]	22-83 Speed at No-Flow [RPM]	23-53 Energy Log	24-1* Drive Bypass
21-59 Ext. 3 Output [%]	22-38 High Speed Power [kW]	22-84 Speed at No-Flow [Hz]	23-54 Reset Energy Log	24-10 Drive Bypass Function
21-6* Ext. CL 3 PID	22-39 High Speed Power [HP]	22-85 Speed at Design Point [RPM]	23-6* Trending	24-11 Drive Bypass Delay Time

24-9* Multi-Motor Funct.	25-25 OBW Time	25-59 Run on Mains Delay	26-2* Analog Input X42/3	26-53 Terminal X42/9 Bus Control
24-90 Missing Motor Function	25-26 Destage At No-Flow	25-8* Status	26-20 Terminal X42/3 Low Voltage	26-54 Terminal X42/9 Timeout Preset
24-91 Missing Motor Coefficient 1	25-27 Stage Function	25-80 Cascade Status	26-21 Terminal X42/3 High Voltage	26-6* Analog Out X42/11
24-92 Missing Motor Coefficient 2	25-28 Stage Function Time	25-81 Pump Status	26-24 Term. X42/3 Low Ref./Feedb. Value	26-60 Terminal X42/11 Output
24-93 Missing Motor Coefficient 3	25-29 Destage Function	25-82 Lead Pump	26-25 Term. X42/3 High Ref./Feedb. Value	26-61 Terminal X42/11 Min. Scale
24-94 Missing Motor Coefficient 4	25-30 Destage Function Time	25-83 Relay Status	26-26 Term. X42/3 Filter Time Constant	26-62 Terminal X42/11 Max. Scale
24-95 Locked Rotor Function	25-4* Staging Settings	25-84 Pump ON Time	26-27 Term. X42/3 Live Zero	26-63 Terminal X42/11 Bus Control
24-96 Locked Rotor Coefficient 1	25-40 Ramp Down Delay	25-85 Relay ON Time	26-3* Analog Input X42/5	26-64 Terminal X42/11 Timeout Preset
24-97 Locked Rotor Coefficient 2	25-41 Ramp Up Delay	25-86 Reset Relay Counters	26-30 Terminal X42/5 Low Voltage	31-** Bypass Option
24-98 Locked Rotor Coefficient 3	25-42 Staging Threshold	25-9* Service	26-31 Terminal X42/5 High Voltage	31-00 Bypass Mode
24-99 Locked Rotor Coefficient 4	25-43 Destaging Threshold	25-90 Pump Interlock	26-34 Term. X42/5 Low Ref./Feedb. Value	31-01 Bypass Start Time Delay
25-** Cascade Controller	25-44 Staging Speed [RPM]	25-91 Manual Alternation	26-35 Term. X42/5 High Ref./Feedb. Value	31-02 Bypass Trip Time Delay
25-0* System Settings	25-45 Staging Speed [Hz]	26-** Analog I/O Option	26-36 Term. X42/5 Filter Time Constant	31-03 Test Mode Activation
25-00 Cascade Controller	25-46 Destaging Speed [RPM]	26-0* Analog I/O Mode	26-37 Term. X42/5 Live Zero	31-10 Bypass Status Word
25-02 Motor Start	25-47 Destaging Speed [Hz]	26-00 Terminal X42/1 Mode	24-4* Analog Out X42/7	31-11 Bypass Running Hours
25-04 Pump Cycling	25-5* Alternation Settings	26-01 Terminal X42/3 Mode	26-40 Terminal X42/7 Output	13-19 Remote Bypass Activation
25-05 Fixed Lead Pump	25-50 Lead Pump Alternation	26-02 Terminal X42/5 Mode	26-41 Terminal X42/7 Min. Scale	35-** Sensor Input Option
25-06 Number of Pumps	25-51 Alternation Event	26-1* Analog Input X42/1	26-42 Terminal X42/7 Max. Scale	35-0* Temp. Input Mode
25-2* Bandwidth Settings	25-52 Alternation Time Interval	26-10 Terminal X42/1 Low Voltage	26-43 Terminal X42/7 Bus Control	35-00 Term. X48/4 Temp. Unit
25-20 Staging Bandwidth	25-53 Alternation Timer Value	26-11 Terminal X42/1 High Voltage	26-44 Terminal X42/7 Timeout Preset	35-01 Term. X48/4 Input Type
25-21 Override Bandwidth	25-54 Alternation Predefined Time	26-14 Term. X42/1 Low Ref./Feedb. Value	26-5* Analog Out X42/9	35-02 Term. X48/7 Temp. Unit
25-22 Fixed Speed Bandwidth	25-55 Alternate if Load < 50%	26-15 Term. X42/1 High Ref./Feedb. Value	26-50 Terminal X42/9 Output	35-03 Term. X48/7 Input Type
25-23 SBW Staging Delay	25-56 Staging Mode at Alternation	26-16 Term. X42/1 Filter Time Constant	26-51 Terminal X42/9 Min. Scale	35-04 Term. X48/10 Temp. Unit
25-24 SBW Destaging Delay	25-58 Run Next Pump Delay	26-17 Term. X42/1 Live Zero	26-52 Terminal X42/9 Max. Scale	35-05 Term. X48/10 Input Type

35-06 Temperature Sensor Alarm Function	35-17 Term. X48/4 High Temp. Limit 35-2* Temp. Input X48/7	35-27 Term. X48/7 High Temp. Limit 35-3* Temp. Input X48/10	35-37 Term. X48/10 High Temp. Limit 35-4* Analog Input X48/2	35-45 Term. X48/2 High Ref./Feedb. Value 35-46 Term. X48/2 Filter Time Constant
35-1* Temp. Input X48/4				
35-14 Term. X48/4 Filter Time Constant	35-24 Term. X48/7 Filter Time Constant	35-34 Term. X48/10 Filter Time Constant	35-42 Term. X48/2 Low Current	35-47 Term. X48/2 Live Zero
35-15 Term. X48/4 Temp. Monitor	35-25 Term. X48/7 Temp. Monitor	35-35 Term. X48/10 Temp. Monitor	35-43 Term. X48/2 High Current	
35-16 Term. X48/4 Low Temp. Limit	35-26 Term. X48/7 Low Temp. Limit	35-36 Term. X48/10 Low Temp. Limit	35-44 Term. X48/2 Low Ref./Feedb. Value	

5.6 Remote Programming with MCT-10

Danfoss has a software program available for developing, storing, and transferring frequency converter programming. The MCT-10 Setup software allows the user to connect a PC to the frequency converter and perform live programming rather than using the LCP. Also, all frequency converter programming can be done off-line and simply downloaded into frequency converter. Or the entire frequency converter profile can be loaded onto the PC for back up storage or analysis.

The USB connector or RS-485 terminal are available for connecting to the frequency converter.

MCT-10 Setup software is available for free download at www.VLT-software.com. A CD disc is also available by requesting part number 130B1000. A user's manual provides detailed operation instructions.

6 Application Set-Up Examples

6.1 Introduction

The examples in this section are intended as a quick reference for common applications.

- Parameter settings are the regional default values unless otherwise indicated (selected in 0-03 Regional Settings)
- Parameters associated with the terminals and their settings are shown next to the drawings
- Where switch settings for analog terminals A53 or A54 are required, these are also shown

6

6.2 Application Examples

		Parameters	
		Function	Setting
		6-22 Terminal 54 Low Current	4mA*
		6-23 Terminal 54 High Current	20mA*
		6-24 Terminal 54 Low Ref./Feedb. Value	0*
		6-25 Terminal 54 High Ref./Feedb. Value	50*
		* = Default Value	

Table 6.1 Analog Current Feedback Transducer

		Parameters	
		Function	Setting
		6-20 Terminal 54 Low Voltage	0.07V*
		6-21 Terminal 54 High Voltage	10V*
		6-24 Terminal 54 Low Ref./Feedb. Value	0*
		6-25 Terminal 54 High Ref./Feedb. Value	50*
		* = Default Value	

Table 6.2 Analog Voltage Feedback Transducer (3-wire)

		Parameters	
		Function	Setting
		6-20 Terminal 54 Low Voltage	0.07V*
		6-21 Terminal 54 High Voltage	10V*
		6-24 Terminal 54 Low Ref./Feedb. Value	0*
		6-25 Terminal 54 High Ref./Feedb. Value	50*
		* = Default Value	

Table 6.3 Analog Voltage Feedback Transducer (4-wire)

		Parameters	
		Function	Setting
		6-10 Terminal 53 Low Voltage	0.07V*
		6-11 Terminal 53 High Voltage	10V*
		6-14 Terminal 53 Low Ref./Feedb. Value	0*
		6-15 Terminal 53 High Ref./Feedb. Value	50*
		* = Default Value	
Notes/comments:			

Table 6.4 Analog Speed Reference (Voltage)

		Parameters	
		Function	Setting
		6-12 Terminal 53 Low Current	4mA*
		6-13 Terminal 53 High Current	20mA*
		6-14 Terminal 53 Low Ref./Feedb. Value	0*
		6-15 Terminal 53 High Ref./Feedb. Value	50*
		* = Default Value	
Notes/comments:			

Table 6.5 Analog Speed Reference (Current)

		Parameters	
		Function	Setting
		5-10 Terminal 18 Digital Input	[8] Start*
		5-12 Terminal 27 Digital Input	[7] External Interlock
		* = Default Value	
Notes/comments:			

Table 6.6 Run/Stop Command with External Interlock

		Parameters	
		Function	Setting
		5-10 Terminal 18 Digital Input	[8] Start*
		5-12 Terminal 27 Digital Input	[7] External Interlock
		* = Default Value	
Notes/comments:		If 5-12 Terminal 27 Digital Input is set to [0] No operation, a jumper wire to terminal 27 is not needed.	

Table 6.7 Run/Stop Command without External Interlock

6

		Parameters	
FC		Function	Setting
+24 V	12		
+24 V	13	5-11 Terminal 19	[1] Reset
D IN	18	Digital Input	
D IN	19		
COM	20		
D IN	27		
D IN	29		
D IN	32		
D IN	33		
D IN	37		
+10 V	50		
A IN	53		
A IN	54		
COM	55		
A OUT	42		
COM	39		
		* = Default Value	
		Notes/comments:	

Table 6.8 External Alarm Reset

		Parameters	
FC		Function	Setting
+24 V	12		
+24 V	13	5-10 Terminal 18	
D IN	18	Digital Input	[8] Start*
D IN	19	5-11 Terminal 19	[52] Run Permissive
COM	20	Digital Input	
D IN	27	5-12 Terminal 27	[7] External Interlock
D IN	29	Digital Input	
D IN	32	5-40 Function	[167] Start command act.
D IN	33	Relay	
D IN	37		
+10 V	50		
A IN	53		
A IN	54		
COM	55		
A OUT	42		
COM	39		
		* = Default Value	
		Notes/comments:	

Table 6.10 Run Permissive

		Parameters	
FC		Function	Setting
+24 V	12		
+24 V	13	6-10 Terminal 53	Low Voltage
D IN	18		0.07V*
D IN	19	6-11 Terminal 53	High Voltage
COM	20		10V*
D IN	27	6-14 Terminal 53	Low Ref./Feedb. Value
D IN	29		0*
D IN	32		
D IN	33	6-15 Terminal 53	High Ref./Feedb. Value
D IN	37		50*.
+10 V	50		
A IN	53		
A IN	54		
COM	55		
A OUT	42		
COM	39		
		* = Default Value	
		Notes/comments:	

Table 6.9 Speed Reference (using a manual potentiometer)

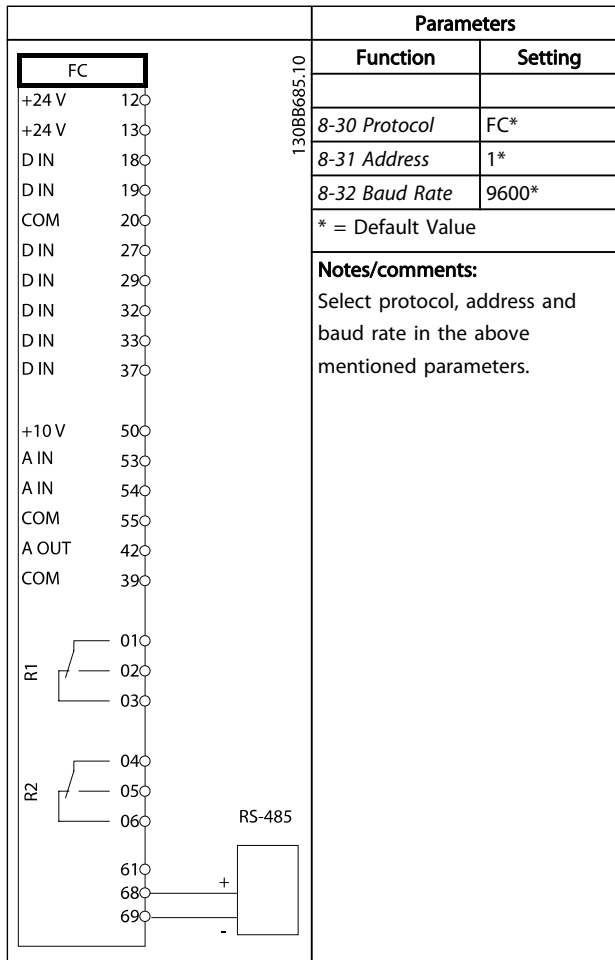

Table 6.11 RS-485 Network Connection (N2, FLN, Modbus RTU, FC)

CAUTION

Thermistors must use reinforced or double insulation to meet PELV insulation requirements.

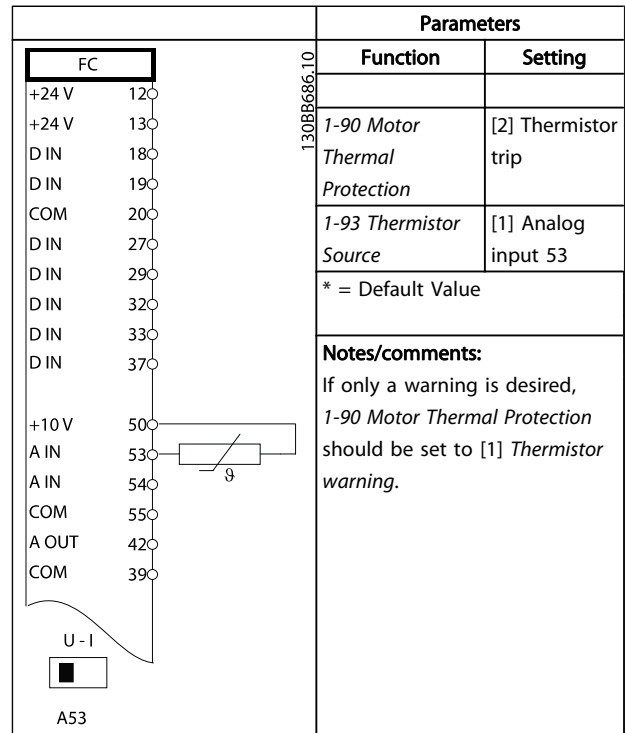

Table 6.12 Motor Thermistor

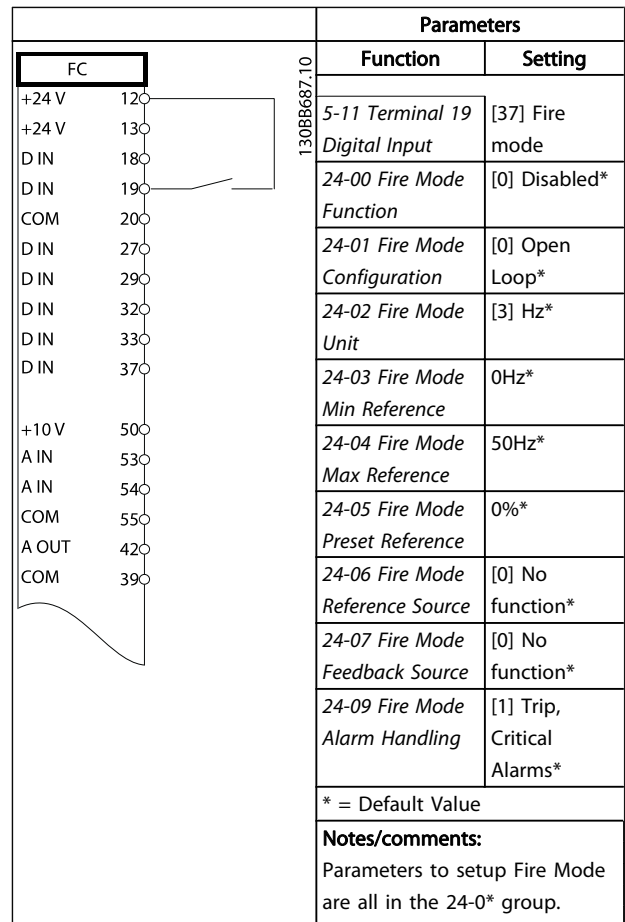

Table 6.13 Fire Mode

7 Status Messages

7.1 Status Display

When the frequency converter is in status mode, status messages are generated automatically from within the frequency converter and appear in the bottom line of the display (see *Illustration 7.1.*)

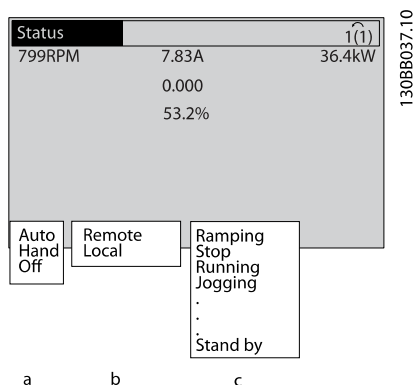

Illustration 7.1 Status Display

- The first word on the status line indicates where the stop/start command originates.
- The second word on the status line indicates where the speed control originates.
- The last part of the status line gives the present frequency converter status. These show the operational mode the frequency converter is in.

NOTE

In auto/remote mode, the frequency converter requires external commands to execute functions.

7.2 Status Message Definitions Table

The next three tables define the meaning of the status message display words.

	Operation Mode
Off	The frequency converter does not react to any control signal until [Auto On] or [Hand On] is pressed.
Auto On	The frequency converter is controlled from the control terminals and/or the serial communication.
Hand On	The frequency converter can be controlled by the navigation keys on the LCP. Stop commands, reset, reversing, DC brake, and other signals applied to the control terminals can override local control.

	Reference Site
Remote	The speed reference is given from external signals, serial communication, or internal preset references.
Local	The frequency converter uses [Hand On] control or reference values from the LCP.

	Operation Status
AC Brake	AC Brake was selected in 2-10 <i>Brake Function</i> . The AC brake over-magnetizes the motor to achieve a controlled slow down.
AMA finish OK	Automatic motor adaptation (AMA) was carried out successfully.
AMA ready	AMA is ready to start. Press [Hand On] to start.
AMA running	AMA process is in progress.
Braking	The brake chopper is in operation. Generative energy is absorbed by the brake resistor.
Braking max.	The brake chopper is in operation. The power limit for the brake resistor defined in 2-12 <i>Brake Power Limit (kW)</i> is reached.
Coast	<ul style="list-style-type: none"> Coast inverse was selected as a function for a digital input (parameter group 5-1*). The corresponding terminal is not connected. Coast activated by serial communication
Ctrl. Ramp-down	Control Ramp-down was selected in 14-10 <i>Mains Failure</i> . <ul style="list-style-type: none"> The mains voltage is below the value set in 14-11 <i>Mains Voltage at Mains Fault</i> at mains fault The frequency converter ramps down the motor using a controlled ramp down

	Operation Status
Current High	The frequency converter output current is above the limit set in <i>4-51 Warning Current High</i> .
Current Low	The frequency converter output current is below the limit set in <i>4-52 Warning Speed Low</i> .
DC Hold	DC hold is selected in <i>1-80 Function at Stop</i> and a stop command is active. The motor is held by a DC current set in <i>2-00 DC Hold/Preheat Current</i> .
DC Stop	The motor is held with a DC current (<i>2-01 DC Brake Current</i>) for a specified time (<i>2-02 DC Braking Time</i>). <ul style="list-style-type: none"> DC Brake is activated in <i>2-03 DC Brake Cut In Speed [RPM]</i> and a Stop command is active. DC Brake (inverse) is selected as a function for a digital input (parameter group 5-1*). The corresponding terminal is not active. The DC Brake is activated via serial communication.
Feedback high	The sum of all active feedbacks is above the feedback limit set in <i>4-57 Warning Feedback High</i> .
Feedback low	The sum of all active feedbacks is below the feedback limit set in <i>4-56 Warning Feedback Low</i> .
Freeze output	The remote reference is active which holds the present speed. <ul style="list-style-type: none"> Freeze output was selected as a function for a digital input (Group 5-1*). The corresponding terminal is active. Speed control is only possible via the terminal functions speed up and speed down. Hold ramp is activated via serial communication.
Freeze output request	A freeze output command has been given, but the motor will remain stopped until a run permissive signal is received.
Freeze ref.	<i>Freeze Reference</i> was chosen as a function for a digital input (parameter group 5-1*). The corresponding terminal is active. The frequency converter saves the actual reference. Changing the reference is now only possible via terminal functions speed up and speed down.
Jog request	A jog command has been given, but the motor will be stopped until a run permissive signal is received via a digital input.

	Operation Status
Jogging	The motor is running as programmed in <i>3-19 Jog Speed [RPM]</i> . <ul style="list-style-type: none"> <i>Jog</i> was selected as function for a digital input (parameter group 5-1*). The corresponding terminal (e.g. Terminal 29) is active. The Jog function is activated via the serial communication. The Jog function was selected as a reaction for a monitoring function (e.g. No signal). The monitoring function is active.
Motor check	In <i>1-80 Function at Stop, Motor Check</i> was selected. A stop command is active. To ensure that a motor is connected to the frequency converter, a permanent test current is applied to the motor.
OVC control	<i>Overvoltage</i> control was activated in <i>2-17 Overvoltage Control</i> . The connected motor is supplying the frequency converter with generative energy. The overvoltage control adjusts the V/Hz ratio to run the motor in controlled mode and to prevent the frequency converter from tripping.
PowerUnit Off	(For frequency converters with an external 24V power supply installed only.) Mains supply to the frequency converter is removed, but the control card is supplied by the external 24V.
Protection md	Protection mode is active. The unit has detected a critical status (an overcurrent or overvoltage). <ul style="list-style-type: none"> To avoid tripping, switching frequency is reduced to 4kHz. If possible, protection mode ends after approximately 10sec. Protection mode can be restricted in <i>14-26 Trip Delay at Inverter Fault</i>
QStop	The motor is decelerating using <i>3-81 Quick Stop Ramp Time</i> . <ul style="list-style-type: none"> <i>Quick stop inverse</i> was chosen as a function for a digital input (parameter group 5-1*). The corresponding terminal is not active. The quick stop function was activated via serial communication.
Ramping	The motor is accelerating/decelerating using the active Ramp Up/Down. The reference, a limit value or a standstill is not yet reached.
Ref. high	The sum of all active references is above the reference limit set in <i>4-55 Warning Reference High</i> .
Ref. low	The sum of all active references is below the reference limit set in <i>4-54 Warning Reference Low</i> .

	Operation Status
Run on ref.	The frequency converter is running in the reference range. The feedback value matches the setpoint value.
Run request	A start command has been given, but the motor is stopped until a run permissive signal is received via digital input.
Running	The motor is driven by the frequency converter.
Sleep Mode	The energy saving function is enabled. This means that at present the motor has stopped, but that it will restart automatically when required.
Speed high	Motor speed is above the value set in <i>4-53 Warning Speed High</i> .
Speed low	Motor speed is below the value set in <i>4-52 Warning Speed Low</i> .
Standby	In Auto On mode, the frequency converter will start the motor with a start signal from a digital input or serial communication.
Start delay	In <i>1-71 Start Delay</i> , a delay starting time was set. A start command is activated and the motor will start after the start delay time expires.
Start fwd/rev	Start forward and start reverse were selected as functions for two different digital inputs (parameter group 5-1). The motor will start in forward or reverse depending on which corresponding terminal is activated.
Stop	The frequency converter has received a stop command from the LCP, digital input or serial communication.
Trip	An alarm occurred and the motor is stopped. Once the cause of the alarm is cleared, the frequency converter can be reset manually by pressing [Reset] or remotely by control terminals or serial communication.
Trip lock	An alarm occurred and the motor is stopped. Once the cause of the alarm is cleared, power must be cycled to the frequency converter. The frequency converter can then be reset manually by pressing [Reset] or remotely by control terminals or serial communication.

8 Warnings and Alarms

8.1 System Monitoring

The frequency converter monitors the condition of its input power, output, and motor factors as well as other system performance indicators. A warning or alarm may not necessarily indicate a problem internal to the frequency converter itself. In many cases it indicates failure conditions from input voltage, motor load or temperature, external signals, or other areas monitored by the frequency converter's internal logic. Be sure to investigate those areas exterior to the frequency converter as indicated in the alarm or warning.

8.2 Warning and Alarm Types

Warnings

A warning is issued when an alarm condition is impending or when an abnormal operating condition is present and may result in the frequency converter issuing an alarm. A warning clears by itself when the abnormal condition is removed.

Alarms

Trip

An alarm is issued when the frequency converter is tripped, that is, the frequency converter suspends operation to prevent frequency converter or system damage. The motor will coast to a stop. The frequency converter logic will continue to operate and monitor the frequency converter status. After the fault condition is remedied, the frequency converter can be reset. It will then be ready to start operation again.

A trip can be reset in any of 4 ways:

- Press [RESET] on the LCP
- Digital reset input command
- Serial communication reset input command
- Auto reset

Trip-lock

An alarm that causes the frequency converter to trip-lock requires that input power be cycled. The motor will coast to a stop. The frequency converter logic will continue to operate and monitor the frequency converter status. Remove input power to the frequency converter and correct the cause of the fault, then restore power. This action puts the frequency converter into a trip condition as described above and may be reset in any of those four ways.

8.3 Warning and Alarm Displays

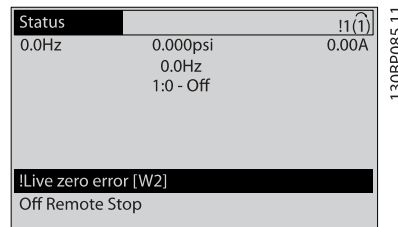

An alarm or trip-lock alarm will flash on display along with the alarm number.

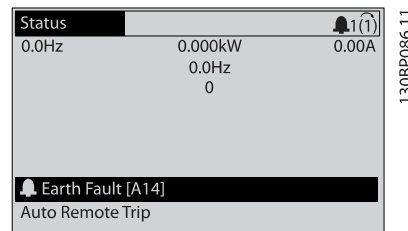

In addition to the text and alarm code on the frequency converter display, the status indicator lights operate.

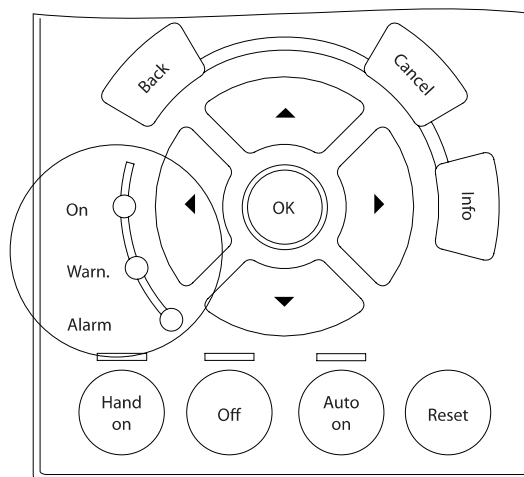

	Warn. LED	Alarm LED
Warning	ON	OFF
Alarm	OFF	ON (Flashing)
Trip-Lock	ON	ON (Flashing)

8.4 Warning and Alarm Definitions

Table 8.1 defines whether a warning is issued prior to an alarm, and whether the alarm trips the unit or trip locks the unit.

No.	Description	Warning	Alarm/ Trip	Alarm/Trip Lock	Parameter Reference
1	10 Volts low	X			
2	Live zero error	(X)	(X)		6-01
4	Mains phase loss	(X)	(X)	(X)	14-12
5	DC link voltage high	X			
6	DC link voltage low	X			
7	DC over voltage	X	X		
8	DC under voltage	X	X		
9	Inverter overloaded	X	X		
10	Motor ETR over temperature	(X)	(X)		1-90
11	Motor thermistor over temperature	(X)	(X)		1-90
12	Torque limit	X	X		
13	Over Current	X	X	X	
14	Earth fault	X	X	X	
15	Hardware mismatch		X	X	
16	Short Circuit		X	X	
17	Control word timeout	(X)	(X)		8-04
23	Internal Fan Fault	X			
24	External Fan Fault	X			14-53
25	Brake resistor short-circuited	X			
26	Brake resistor power limit	(X)	(X)		2-13
27	Brake chopper short-circuited	X	X		
28	Brake check	(X)	(X)		2-15
29	Drive over temperature	X	X	X	
30	Motor phase U missing	(X)	(X)	(X)	4-58
31	Motor phase V missing	(X)	(X)	(X)	4-58
32	Motor phase W missing	(X)	(X)	(X)	4-58
33	Inrush fault		X	X	
34	Fieldbus communication fault	X	X		
35	Out of frequency range	X	X		
36	Mains failure	X	X		
37	Phase Imbalance	X	X		
38	Internal fault		X	X	
39	Heatsink sensor		X	X	
40	Overload of Digital Output Terminal 27	(X)			5-00, 5-01
41	Overload of Digital Output Terminal 29	(X)			5-00, 5-02
42	Overload of Digital Output On X30/6	(X)			5-32
42	Overload of Digital Output On X30/7	(X)			5-33
46	Pwr. card supply		X	X	
47	24 V supply low	X	X	X	
48	1.8 V supply low		X	X	
49	Speed limit	X	(X)		1-86
50	AMA calibration failed		X		
51	AMA check U_{nom} and I_{nom}		X		
52	AMA low I_{nom}		X		
53	AMA motor too big		X		
54	AMA motor too small		X		
55	AMA Parameter out of range		X		
56	AMA interrupted by user		X		

No.	Description	Warning	Alarm/ Trip	Alarm/Trip Lock	Parameter Reference
57	AMA timeout		X		
58	AMA internal fault	X	X		
59	Current limit	X			
60	External Interlock	X			
62	Output Frequency at Maximum Limit	X			
64	Voltage Limit	X			
65	Control Board Over-temperature	X	X	X	
66	Heat sink Temperature Low	X			
67	Option Configuration has Changed		X		
69	Pwr. Card Temp		X	X	
70	Illegal FC configuration			X	
71	PTC 1 Safe Stop	X	X ¹⁾		
72	Dangerous Failure			X ¹⁾	
73	Safe Stop Auto Restart				
76	Power Unit Setup	X			
79	Illegal PS config		X	X	
80	Drive Initialized to Default Value		X		
91	Analog input 54 wrong settings			X	
92	NoFlow	X	X		22-2*
93	Dry Pump	X	X		22-2*
94	End of Curve	X	X		22-5*
95	Broken Belt	X	X		22-6*
96	Start Delayed	X			22-7*
97	Stop Delayed	X			22-7*
98	Clock Fault	X			0-7*
201	Fire M was Active				
202	Fire M Limits Exceeded				
203	Missing Motor				
204	Locked Rotor				
243	Brake IGBT	X	X		
244	Heatsink temp	X	X	X	
245	Heatsink sensor		X	X	
246	Pwr.card supply		X	X	
247	Pwr.card temp		X	X	
248	Illegal PS config		X	X	
250	New spare parts			X	
251	New Type Code		X	X	

Table 8.1 Alarm/Warning code list

(X) Dependent on parameter

¹⁾ Cannot be Auto reset via *14-20 Reset Mode*

8.4.1 Fault Messages

The warning/alarm information below defines the warning/ alarm condition, provides the probable cause for the condition, and details a remedy or troubleshooting procedure.

WARNING 1, 10 volts low

The control card voltage is below 10 V from terminal 50. Remove some of the load from terminal 50, as the 10 V supply is overloaded. Max. 15 mA or minimum 590 Ω.

This condition can be caused by a short in a connected potentiometer or improper wiring of the potentiometer.

Troubleshooting

Remove the wiring from terminal 50. If the warning clears, the problem is with the customer wiring. If the warning does not clear, replace the control card.

WARNING/ALARM 2, Live zero error

This warning or alarm will only appear if programmed by the user in *6-01 Live Zero Timeout Function*. The signal on one of the analog inputs is less than 50% of the minimum value programmed for that input. This condition can be caused by broken wiring or faulty device sending the signal.

Troubleshooting

Check connections on all the analog input terminals. Control card terminals 53 and 54 for signals, terminal 55 common. MCB 101 terminals 11 and 12 for signals, terminal 10 common. MCB 109 terminals 1, 3, 5 for signals, terminals 2, 4, 6 common).

Check that the frequency converter programming and switch settings match the analog signal type.

Perform Input Terminal Signal Test.

WARNING/ALARM 4, Mains phase loss

A phase is missing on the supply side, or the mains voltage imbalance is too high. This message also appears for a fault in the input rectifier on the frequency converter. Options are programmed at *14-12 Function at Mains Imbalance*.

Troubleshooting

Check the supply voltage and supply currents to the frequency converter.

WARNING 5, DC link voltage high

The intermediate circuit voltage (DC) is higher than the high voltage warning limit. The limit is dependent on the frequency converter voltage rating. The frequency converter is still active.

WARNING 6, DC link voltage low

The intermediate circuit voltage (DC) is lower than the low voltage warning limit. The limit is dependent on the frequency converter voltage rating. The frequency converter is still active.

WARNING/ALARM 7, DC overvoltage

If the intermediate circuit voltage exceeds the limit, the frequency converter trips after a time.

Troubleshooting

Connect a brake resistor

Extend the ramp time

Change the ramp type

Activate functions in *2-10 Brake Function*

Increase *14-26 Trip Delay at Inverter Fault*

WARNING/ALARM 8, DC under voltage

If the intermediate circuit voltage (DC) drops below the under voltage limit, the frequency converter checks if a 24 VDC backup supply is connected. If no 24 VDC backup supply is connected, the frequency converter trips after a fixed time delay. The time delay varies with unit size.

Troubleshooting

Check that the supply voltage matches the frequency converter voltage.

Perform Input voltage test

Perform soft charge and rectifier circuit test

WARNING/ALARM 9, Inverter overloaded

The frequency converter is about to cut out because of an overload (too high current for too long). The counter for electronic, thermal inverter protection gives a warning at 98% and trips at 100%, while giving an alarm. The frequency converter *cannot* be reset until the counter is below 90%. The fault is that the frequency converter is overloaded by more than 100% for too long.

Troubleshooting

Compare the output current shown on the LCP with the frequency converter rated current.

Compare the output current shown on the LCP with measured motor current.

Display the Thermal Drive Load on the LCP and monitor the value. When running above the frequency converter continuous current rating, the counter should increase. When running below the frequency converter continuous current rating, the counter should decrease.

See the derating section in the *Design Guide* for more details if a high switching frequency is required.

WARNING/ALARM 10, Motor overload temperature

According to the electronic thermal protection (ETR), the motor is too hot. Select whether the frequency converter gives a warning or an alarm when the counter reaches 100% in *1-90 Motor Thermal Protection*. The fault occurs when the motor is overloaded by more than 100% for too long.

Troubleshooting

Check for motor overheating.

Check if the motor is mechanically overloaded

Check that the motor current set in *1-24 Motor Current* is correct.

Ensure that Motor data in parameters 1-20 through 1-25 are set correctly.

If an external fan is in use, check in *1-91 Motor External Fan* that it is selected.

Running AMA in *1-29 Automatic Motor Adaptation (AMA)* may tune the frequency controller to the motor more accurately and reduce thermal loading.

WARNING/ALARM 11, Motor thermistor over temp

The thermistor might be disconnected. Select whether the frequency converter gives a warning or an alarm in *1-90 Motor Thermal Protection*.

Troubleshooting

Check for motor overheating.

Check if the motor is mechanically overloaded.

When using terminal 53 or 54, check that the thermistor is connected correctly between either terminal 53 or 54 (analog voltage input) and terminal 50 (+10 V supply) and that the terminal

switch for 53 or 54 is set for voltage. Check *1-93 Thermistor Source* selects terminal 53 or 54.

When using digital inputs 18 or 19, check that the thermistor is connected correctly between either terminal 18 or 19 (digital input PNP only) and terminal 50. Check *1-93 Thermistor Source* selects terminal 18 or 19.

WARNING/ALARM 12, Torque limit

The torque has exceeded the value in *4-16 Torque Limit Motor Mode* or the value in *4-17 Torque Limit Generator Mode*. *14-25 Trip Delay at Torque Limit* can change this from a warning only condition to a warning followed by an alarm.

Troubleshooting

If the motor torque limit is exceeded during ramp up, extend the ramp up time.

If the generator torque limit is exceeded during ramp down, extend the ramp down time.

If torque limit occurs while running, possibly increase the torque limit. Be sure the system can operate safely at a higher torque.

Check the application for excessive current draw on the motor.

WARNING/ALARM 13, Over current

The inverter peak current limit (approx. 200% of the rated current) is exceeded. The warning lasts about 1.5 sec., then the frequency converter trips and issues an alarm. This fault may be caused by shock loading or fast acceleration with high inertia loads. If extended mechanical brake control is selected, trip can be reset externally.

Troubleshooting

Remove power and check if the motor shaft can be turned.

Check that the motor size matches the frequency converter.

Check parameters 1-20 through 1-25 for correct motor data.

ALARM 14, Earth (ground) fault

There is current from the output phases to earth, either in the cable between the frequency converter and the motor or in the motor itself.

Troubleshooting

Remove power to the frequency converter and repair the earth fault.

Check for earth faults in the motor by measuring the resistance to ground of the motor leads and the motor with a megohmmeter.

ALARM 15, Hardware mismatch

A fitted option is not operational with the present control board hardware or software.

Record the value of the following parameters and contact your Danfoss supplier:

15-40 FC Type

15-41 Power Section

15-42 Voltage

15-43 Software Version

15-45 Actual Typecode String

15-49 SW ID Control Card

15-50 SW ID Power Card

15-60 Option Mounted

15-61 Option SW Version

ALARM 16, Short circuit

There is a short circuit in the motor or motor wiring.

Remove power to the frequency converter and repair the short circuit.

WARNING/ALARM 17, Control word timeout

There is no communication to the frequency converter.

The warning will only be active when *8-04 Control Timeout Function* is NOT set to [0] OFF.

If *8-04 Control Timeout Function* is set to *Stop and Trip*, a warning appears and the frequency converter ramps down until it stops then displays an alarm.

Troubleshooting

Check connections on the serial communication cable.

Increase *8-03 Control Timeout Time*

Check operation of the communication equipment.

Verify proper installation based on EMC requirements.

WARNING 23, Internal fan fault

The fan warning function checks if the fan is running. The fan warning can be disabled in *14-53 Fan Monitor*.

Troubleshooting

Check for proper fan operation.

Cycle power to the frequency converter and check that the fan operates briefly at start up.

Check the sensors on the heatsink and control card.

WARNING 24, External fan fault

The fan warning function checks if the fan is running. The fan warning can be disabled in *14-53 Fan Monitor*.

Troubleshooting

Check for proper fan operation.

Cycle power to the frequency converter and check that the fan operates briefly at start up.

Check the sensors on the heatsink and control card.

WARNING 25, Brake resistor short circuit

The brake resistor is monitored during operation. If a short circuit occurs, the brake function is disabled and the warning appears. The frequency converter is still operational but without the brake function. Remove power to the frequency

converter and replace the brake resistor (see *2-15 Brake Check*).

WARNING/ALARM 26, Brake resistor power limit

The power transmitted to the brake resistor is calculated as a mean value over the last 120 seconds of run time. The calculation is based on the intermediate circuit voltage and the brake resistance value set in *2-16 AC brake Max. Current*. The warning is active when the dissipated braking is higher than 90% of the brake resistance power. If *Trip [2]* is selected in *2-13 Brake Power Monitoring*, the frequency converter will trip when the dissipated braking power reaches 100%.

WARNING/ALARM 27, Brake chopper fault

The brake transistor is monitored during operation and if a short circuit occurs, the brake function is disabled and a warning is issued. The frequency converter is still operational but, since the brake transistor has short-circuited, substantial power is transmitted to the brake resistor, even if it is inactive.

Remove power to the frequency converter and remove the brake resistor.

WARNING/ALARM 28, Brake check failed

The brake resistor is not connected or not working. Check *2-15 Brake Check*.

ALARM 29, Heatsink temp

The maximum temperature of the heatsink has been exceeded. The temperature fault will not reset until the temperature falls below the reset heatsink temperature. The trip and reset points are based on the frequency converter power size.

Troubleshooting

Check for the following conditions.

- Ambient temperature too high.
- Motor cable too long.
- Incorrect airflow clearance above and below the frequency converter.
- Blocked airflow around the frequency converter.
- Damaged heatsink fan.
- Dirty heatsink.

ALARM 30, Motor phase U missing

Motor phase U between the frequency converter and the motor is missing.

Remove power from the frequency converter and check motor phase U.

ALARM 31, Motor phase V missing

Motor phase V between the frequency converter and the motor is missing.

Remove power from the frequency converter and check motor phase V.

ALARM 32, Motor phase W missing

Motor phase W between the frequency converter and the motor is missing.

Remove power from the frequency converter and check motor phase W.

ALARM 33, Inrush fault

Too many power-ups have occurred within a short time period. Let the unit cool to operating temperature.

WARNING/ALARM 34, Fieldbus communication fault

Communication between the fieldbus and the communication option card is not operating.

WARNING/ALARM 36, Mains failure

This warning/alarm is only active if the supply voltage to the frequency converter is lost and *14-10 Mains Failure* is NOT set to [0] *No Function*. Check the fuses to the frequency converter and mains power supply to the unit.

ALARM 38, Internal fault

When an internal fault occurs, a code number defined in the table below is displayed.

Troubleshooting

- Cycle power to the frequency converter.
- Check that the option is properly installed.
- Check for loose or missing wiring.

It may be necessary to contact your Danfoss supplier or service department. Note the code number for further troubleshooting directions.

No.	Text
0	Serial port cannot be initialised. Contact yourDanfoss supplier or DanfossService Department.
256-258	Power EEPROM data is defect or too old
512-519	Internal fault. Contact yourDanfoss supplier or DanfossService Department.
783	Parameter value outside of min/max limits
1024-1284	Internal fault. Contact your Danfoss supplier or the Danfoss Service Department.
1299	Option SW in slot A is too old
1300	Option SW in slot B is too old
1302	Option SW in slot C1 is too old
1315	Option SW in slot A is not supported (not allowed)
1316	Option SW in slot B is not supported (not allowed)
1318	Option SW in slot C1 is not supported (not allowed)
1379-2819	Internal fault. Contact yourDanfoss supplier or DanfossService Department.
2820	LCP stack overflow
2821	Serial port overflow
2822	USB port overflow
3072-5122	Parameter value is outside its limits
5123	Option in slot A: Hardware incompatible with control board hardware
5124	Option in slot B: Hardware incompatible with control board hardware
5125	Option in slot C0: Hardware incompatible with control board hardware
5126	Option in slot C1: Hardware incompatible with control board hardware

No.	Text
5376-6231	Internal fault. Contact your Danfoss supplier or Danfoss Service Department.

ALARM 39, Heatsink sensor

No feedback from the heatsink temperature sensor.

The signal from the IGBT thermal sensor is not available on the power card. The problem could be on the power card, on the gate drive card, or the ribbon cable between the power card and gate drive card.

WARNING 40, Overload of digital output terminal 27

Check the load connected to terminal 27 or remove short-circuit connection. Check *5-00 Digital I/O Mode* and *5-01 Terminal 27 Mode*.

WARNING 41, Overload of digital output terminal 29

Check the load connected to terminal 29 or remove short-circuit connection. Check *5-00 Digital I/O Mode* and *5-02 Terminal 29 Mode*.

WARNING 42, Overload of digital output on X30/6 or overload of digital output on X30/7

For X30/6, check the load connected to X30/6 or remove short-circuit connection. Check *5-32 Term X30/6 Digi Out (MCB 101)*.

For X30/7, check the load connected to X30/7 or remove short-circuit connection. Check *5-33 Term X30/7 Digi Out (MCB 101)*.

ALARM 45, Earth fault 2

Earth (ground) fault on start up.

Troubleshooting

Check for proper earthing (grounding) and loose connections.

Check for proper wire size.

Check motor cables for short-circuits or leakage currents.

ALARM 46, Power card supply

The supply on the power card is out of range.

There are three power supplies generated by the switch mode power supply (SMPS) on the power card: 24 V, 5 V, +/- 18 V. When powered with 24 VDC with the MCB 107 option, only the 24 V and 5 V supplies are monitored. When powered with three phase mains voltage, all three supplied are monitored.

Troubleshooting

Check for a defective power card.

Check for a defective control card.

Check for a defective option card.

If a 24 VDC power supply is used, verify proper supply power.

WARNING 47, 24 V supply low

The 24 V DC is measured on the control card. The external 24V DC backup power supply may be overloaded, otherwise contact your Danfoss supplier.

WARNING 48, 1.8 V supply low

The 1.8V DC supply used on the control card is outside of allowable limits. The power supply is measured on the control card. Check for a defective control card. If an option card is present, check for an overvoltage condition.

WARNING 49, Speed limit

When the speed is not within the specified range in *4-11 Motor Speed Low Limit [RPM]* and *4-13 Motor Speed High Limit [RPM]*, the frequency converter will show a warning. When the speed is below the specified limit in *1-86 Trip Speed Low [RPM]* (except when starting or stopping) the frequency converter will trip.

ALARM 50, AMA calibration failed

Contact your Danfoss supplier or Danfoss Service Department.

ALARM 51, AMA check U_{nom} and I_{nom}

The settings for motor voltage, motor current, and motor power are wrong. Check the settings in parameters 1-20 to 1-25.

ALARM 52, AMA low I_{nom}

The motor current is too low. Check the setting in *4-18 Current Limit*.

ALARM 53, AMA motor too big

The motor is too big for the AMA to operate.

ALARM 54, AMA motor too small

The motor is too small for the AMA to operate.

ALARM 55, AMA Parameter out of range

The parameter values of the motor are outside of the acceptable range. AMA will not run.

ALARM 56, AMA interrupted by user

The AMA has been interrupted by the user.

ALARM 57, AMA timeout

Try to restart AMA again. Repeated restarts may over heat the motor.

ALARM 58, AMA internal fault

Contact your Danfoss supplier.

WARNING 59, Current limit

The current is higher than the value in *4-18 Current Limit*. Ensure that Motor data in parameters 1-20 through 1-25 are set correctly. Possibly increase the current limit. Be sure the system can operate safely at a higher limit.

ALARM 60, External interlock

A digital input signal is indicating a fault condition external to the frequency controller. An external interlock has commanded the frequency controller to trip. Clear the external fault condition. To resume normal operation, apply 24 VDC to the terminal programmed for external interlock. Reset the frequency converter.

WARNING 62, Output frequency at maximum limit

The output frequency has reached the value set in *4-19 Max Output Frequency*. Check the application to determine the cause. Possibly increase the output frequency limit. Be sure the system can operate safely at a higher output frequency. The warning will clear when the output drops below the maximum limit.

WARNING/ALARM 65, Control card over temperature

The cutout temperature of the control card is 80° C.

Troubleshooting

Check that the ambient operating temperature is within limits.

Check for clogged filters.

Check fan operation.

Check the control card.

WARNING 66, Heatsink temperature low

The frequency converter is too cold to operate. This warning is based on the temperature sensor in the IGBT module. Increase the ambient temperature of the unit. Also, a trickle amount of current can be supplied to the frequency controller whenever the motor is stopped by setting *2-00 DC Hold/Preheat Current* at 5% and *1-80 Function at Stop*.

ALARM 67, Option module configuration has changed

One or more options have either been added or removed since the last power down. Check that the configuration change is intentional and reset the frequency controller.

ALARM 68, Safe stop activated

Loss of the 24 VDC signal on terminal 37 has caused the frequency controller to trip. To resume normal operation, apply 24 VDC to terminal 37 and reset the frequency controller.

ALARM 69, Power card temperature

The temperature sensor on the power card is either too hot or too cold.

Troubleshooting

Check that the ambient operating temperature is within limits.

Check for clogged filters.

Check fan operation.

Check the power card.

ALARM 70, Illegal FC configuration

The control card and power card are incompatible. Contact your supplier with the typecode of the unit from the nameplate and the part numbers of the cards to check compatibility.

ALARM 80, Drive initialised to default value

Parameter settings are initialised to default settings after a manual reset. Reset the unit to clear the alarm.

ALARM 92, No flow

A no-flow condition has been detected in the system. *22-23 No-Flow Function* is set for alarm. Troubleshoot the system and reset the frequency converter after the fault has been cleared.

ALARM 93, Dry pump

A no-flow condition in the system with the frequency converter operating at high speed may indicate a dry pump. *22-26 Dry Pump Function* is set for alarm. Troubleshoot the system and reset the frequency converter after the fault has been cleared.

ALARM 94, End of curve

Feedback is lower than the set point. This may indicate leakage in the system. *22-50 End of Curve Function* is set for alarm. Troubleshoot the system and reset the frequency converter after the fault has been cleared.

ALARM 95, Broken belt

Torque is below the torque level set for no load, indicating a broken belt. *22-60 Broken Belt Function* is set for alarm. Troubleshoot the system and reset the frequency converter after the fault has been cleared.

ALARM 96, Start delayed

Motor start has been delayed due to short-cycle protection. *22-76 Interval between Starts* is enabled. Troubleshoot the system and reset the frequency converter after the fault has been cleared.

WARNING 97, Stop delayed

Stopping the motor has been delayed due to short cycle protection. *22-76 Interval between Starts* is enabled. Troubleshoot the system and reset the frequency converter after the fault has been cleared.

WARNING 98, Clock fault

Time is not set or the RTC clock has failed. Reset the clock in *0-70 Date and Time*.

WARNING, 200 Fire mode

This indicates the frequency controller is operating in fire mode. The warning clears when fire mode is removed. See the fire mode data in the alarm log.

WARNING 201, Fire mode was active

This indicates the frequency controller had entered fire mode. Cycle power to the unit to remove the warning. See the fire mode data in the alarm log.

WARNING 202, Fire mode limits exceeded

While operating in fire mode one or more alarm conditions has been ignored which would normally trip the unit. Operating in this condition voids unit warranty. Cycle power to the unit to remove the warning. See the fire mode data in the alarm log.

WARNING 203, Missing motor

With a frequency converter operating multi-motors, an under-load condition was detected. This could indicate a missing motor. Inspect the system for proper operation.

WARNING 204, Locked rotor

With a frequency converter operating multi-motors, an overload condition was detected. This could indicate a locked rotor. Inspect the motor for proper operation.

WARNING 250, New spare part

A component in the frequency converter has been replaced. Reset the frequency converter for normal operation.

WARNING 251, New typecode

A component in the frequency converter has been replaced and the typecode changed. Reset the frequency converter for normal operation.

9 Basic Troubleshooting

9.1 Start Up and Operation

Symptom	Possible Cause	Test	Solution
Display dark / No function	Missing input power	See <i>Table 3.1</i> .	Check the input power source.
	Missing or open fuses or circuit breaker tripped	See open fuses and tripped circuit breaker in this table for possible causes.	Follow the recommendations provided
	No power to the LCP	Check the LCP cable for proper connection or damage.	Replace the faulty LCP or connection cable.
	Shortcut on control voltage (terminal 12 or 50) or at control terminals	Check the 24V control voltage supply for terminal 12/13 to 20-39 or 10V supply for terminal 50 to 55.	Wire the terminals properly.
	Wrong LCP (LCP from VLT® 2800 or 5000/6000/8000/ FCD or FCM)		Use only LCP 101 (P/N 130B1124) or LCP 102 (P/N. 130B1107).
	Wrong contrast setting		Press [Status] + Up/Down arrows to adjust the contrast.
	Display (LCP) is defective	Test using a different LCP.	Replace the faulty LCP or connection cable.
Intermittent display	Internal voltage supply fault or SMPS is defective		Contact supplier.
Intermittent display	Overloaded power supply (SMPS) due to improper control wiring or a fault within the frequency converter	To rule out a problem in the control wiring, disconnect all control wiring by removing the terminal blocks.	If the display stays lit, then the problem is in the control wiring. Check the wiring for shorts or incorrect connections. If the display continues to cut out, follow the procedure for display dark.
Motor not running	Service switch open or missing motor connection	Check if the motor is connected and the connection is not interrupted (by a service switch or other device).	Connect the motor and check the service switch.
	No mains power with 24V DC option card	If the display is functioning but no output, check that mains power is applied to the frequency converter.	Apply mains power to run the unit.
	LCP Stop	Check if [Off] has been pressed.	Press [Auto On] or [Hand On] (depending on your operation mode) to run the motor.
	Missing start signal (Standby)	Check <i>5-10 Start</i> for correct setting for terminal 18 (use default setting).	Apply a valid start signal to start the motor.
	Motor coast signal active (Coasting)	Check <i>5-12 Coast inv.</i> for correct setting for terminal 27 (use default setting).	Apply 24V on terminal 27 or programm this terminal to <i>No operation</i> .
Motor not running	Wrong reference signal source	Check reference signal: Local, remote or bus reference? Preset reference active? Terminal connection correct? Scaling of terminals correct? Reference signal available?	Program correct settings Check <i>3-13 Reference site</i> . Set preset reference active <i>3-1* References</i> . Check for correct wiring. Check scaling of terminals. Check reference signal.

Symptom	Possible Cause	Test	Solution
Motor running in wrong direction	Motor rotation limit	Check that 4-10 <i>Motor speed direction</i> is programmed correctly.	Program correct settings.
	Active reversing signal	Check if a reversing command is programmed for the terminal in 5-1* <i>Digital inputs</i> .	Deactivate reversing signal.
	Wrong motor phase connection		See 3.5.1 <i>Check Motor Rotation</i> in this manual.
Motor is not reaching maximum speed	Frequency limits set wrong	Check output limits in 4-13 <i>Motor speed high limit [RPM]</i> , 4-14 <i>Motor speed high limit [Hz]</i> , and 4-19 <i>Max output frequency</i> .	Program correct limits.
	Reference input signal not scaled correctly	Check reference input signal scaling in 6-* <i>Analog I/O mode</i> and 3-1* <i>References</i> .	Program correct settings.
Motor speed unstable	Possible incorrect parameter settings	Check the settings of all motor parameters, including all motor compensation settings. For closed loop operation, check PID settings.	Check settings in 1-6* <i>Analog I/O mode</i> . For closed loop operation check settings in 20-0* <i>Feedback</i> .
Motor runs rough	Possible over-magnetization	Check for incorrect motor settings in all motor parameters.	Check motor settings in 1-2* <i>Motor data</i> , 1-3* <i>Adv motor data</i> , and 1-5* <i>Load indep. setting</i> .
Motor will not brake	Possible incorrect settings in the brake parameters. Possible too short ramp down times.	Check brake parameters. Check ramp time settings.	Check 2-0* <i>DC brake</i> and 3-0* <i>Reference limits</i> .
Open power fuses or circuit breaker trip	Phase to phase short	Motor or panel has a short phase to phase. Check motor and panel phase to for shorts.	Eliminate any shorts detected.
	Motor overload	Motor is overloaded for the application.	Perform startup test and verify motor current is within specifications. If motor current is exceeding nameplate full load current, motor may run only with reduced load. Review the specifications for the application.
	Loose connections	Perform pre-startup check for loose connections.	Tighten loose connections.
Mains current imbalance greater than 3%	Problem with mains power (See <i>Alarm 4 Mains phase loss</i> description)	Rotate input power leads into the drive one position: A to B, B to C, C to A.	If imbalanced leg follows the wire, it is a power problem. Check mains power supply.
	Problem with the frequency converter unit	Rotate input power leads into the frequency converter one position: A to B, B to C, C to A.	If imbalance leg stays on same input terminal, it is a problem with the unit. Contact supplier.
Motor current imbalance greater than 3%	Problem with motor or motor wiring	Rotate output motor leads one position: U to V, V to W, W to U.	If imbalanced leg follows the wire, the problem is in the motor or motor wiring. Check motor and motor wiring.
	Problem with drive unit	Rotate output motor leads one position: U to V, V to W, W to U.	If imbalance leg stays on same output terminal, it is a problem with the unit. Contact supplier.

10 Specifications

10.1 Power-dependent Specifications

Mains supply 200 - 240 VAC - Normal overload 110% for 1 minute						
Frequency converter	P1K1	P1K5	P2K2	P3K0	P3K7	
Typical Shaft Output [kW]	1.1	1.5	2.2	3	3.7	
IP20/Chassis (A2+A3 may be converted to IP21 using a conversion kit. (Please also see <i>Mechanical mounting</i> and <i>IP21/Type 1 Enclosure kit</i> in the Design Guide.))	A2	A2	A2	A3	A3	
IP55/NEMA 12	A4/A5	A4/A5	A4/A5	A5	A5	
IP66/NEMA 12	A4/A5	A4/A5	A4/A5	A5	A5	
Typical Shaft Output [HP] at 208 V	1.5	2.0	2.9	4.0	4.9	
Output current						
 130BA058.10	Continuous (3 x 200-240 V) [A]	6.6	7.5	10.6	12.5	16.7
	Intermittent (3 x 200-240 V) [A]	7.3	8.3	11.7	13.8	18.4
	Continuous kVA (208 V AC) [kVA]	2.38	2.70	3.82	4.50	6.00
Max. input current						
 130BA057.10	Continuous (3 x 200-240 V) [A]	5.9	6.8	9.5	11.3	15.0
	Intermittent (3 x 200-240 V) [A]	6.5	7.5	10.5	12.4	16.5
Additional specifications						
Estimated power loss at rated max. load [W] ⁴⁾	63	82	116	155	185	
Max. cable size (mains, motor, brake) [mm ² /AWG] ²⁾	4/10					
Weight enclosure IP20 [kg]	4.9	4.9	4.9	6.6	6.6	
Weight enclosure IP21 [kg]	5.5	5.5	5.5	7.5	7.5	
Weight enclosure IP55 [kg] (A4/A5)	9.7/13.5	9.7/13.5	9.7/13.5	13.5	13.5	
Weight enclosure IP 66 [kg] (A4/A5)	9.7/13.5	9.7/13.5	9.7/13.5	13.5	13.5	
Efficiency ³⁾	0.96	0.96	0.96	0.96	0.96	

Table 10.1 Mains Supply 200 - 240 VAC

10

Mains supply 3 x 200 - 240 VAC - Normal overload 110% for 1 minute											
IP20/Chassis (B3+4 and C3+4 may be converted to IP21 using a conversion kit. (Please see also items Mechanical mounting and IP21/Type 1 Enclosure kit in the Design Guide.))	B3		B3		B3		B3		B3		
	B1	B1	B1	B1	B1	B1	B1	B1	B1	B1	
IP21/NEMA 1	B1		B1		B1		B1		B1		
IP55/NEMA 12	B1		B1		B1		B1		B1		
IP66/NEMA 12	B1		B1		B1		B1		B1		
Frequency converter	P5K5	P7K5	P11K	P15K	P18K	P22K	P30K	P37K	P45K	P45K	
Typical Shaft Output [kW]	5.5	7.5	11	15	18.5	22	30	37	45	45	
Typical Shaft Output [HP] at 208 V	7.5	10	15	20	25	30	40	50	60	60	
Output current											
	Continuous (3 x 200-240 V) [A]		24.2	30.8	46.2	59.4	74.8	88.0	115	143	170
	Intermittent (3 x 200-240 V) [A]		26.6	33.9	50.8	65.3	82.3	96.8	127	157	187
	Continuous kVA (208 V AC) [kVA]		8.7	11.1	16.6	21.4	26.9	31.7	41.4	51.5	61.2
Max. input current											
	Continuous (3 x 200-240 V) [A]		22.0	28.0	42.0	54.0	68.0	80.0	104.0	130.0	154.0
	Intermittent (3 x 200-240 V) [A]		24.2	30.8	46.2	59.4	74.8	88.0	114.0	143.0	169.0
Additional Specifications											
Estimated power loss at rated max. load [W] ⁴⁾			269	310	447	602	737	845	1140	1353	1636
Max. cable size (mains, motor, brake) [mm ² /AWG] ²⁾			10/7		35/2		50/1/0 (B4=35/2)		95/4/0		120/250 MCM
With mains disconnect switch included:			16/6		35/2		35/2		70/3/0		185/ kcmil350
Weight enclosure IP20 [kg]			12	12	12	23.5	23.5	35	35	50	50
Weight enclosure IP21 [kg]			23	23	23	27	45	45	45	65	65
Weight enclosure IP55 [kg]			23	23	23	27	45	45	45	65	65
Weight enclosure IP66 [kg]			23	23	23	27	45	45	45	65	65
Efficiency ³⁾			0.96	0.96	0.96	0.96	0.96	0.97	0.97	0.97	0.97

Table 10.2 Mains Supply 3 x 200 - 240 VAC

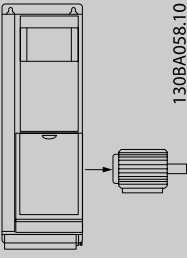
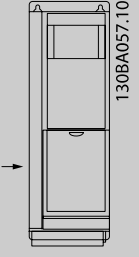
Mains Supply 3 x 380 - 480 VAC - Normal overload 110% for 1 minute									
Frequency converter	P1K1	P1K5	P2K2	P3K0	P4K0	P5K5	P7K5		
Typical Shaft Output [kW]	1.1	1.5	2.2	3	4	5.5	7.5		
Typical Shaft Output [HP] at 460 V	1.5	2.0	2.9	4.0	5.0	7.5	10		
IP 20 / Chassis	A2								
(A2+A3 may be converted to IP21 using a conversion kit. (Please see also items Mechanical mounting and IP 21/Type 1 Enclosure kit in the Design Guide.))									
IP 55 / NEMA 12	A4/A5								
IP 66 / NEMA 12	A4/A5								
Output current									
	Continuous (3 x 380-440 V) [A]	3	4.1	5.6	7.2	10	13	16	
	Intermittent (3 x 380-440 V) [A]	3.3	4.5	6.2	7.9	11	14.3	17.6	
	Continuous (3 x 441-480 V) [A]	2.7	3.4	4.8	6.3	8.2	11	14.5	
	Intermittent (3 x 441-480 V) [A]	3.0	3.7	5.3	6.9	9.0	12.1	15.4	
	Continuous kVA (400 V AC) [kVA]	2.1	2.8	3.9	5.0	6.9	9.0	11.0	
Continuous kVA (460 V AC) [kVA]	2.4 2.7 3.8 5.0 6.5 8.8 11.6								
Max. input current									
	Continuous (3 x 380-440 V) [A]	2.7	3.7	5.0	6.5	9.0	11.7	14.4	
	Intermittent (3 x 380-440 V) [A]	3.0	4.1	5.5	7.2	9.9	12.9	15.8	
	Continuous (3 x 441-480 V) [A]	2.7	3.1	4.3	5.7	7.4	9.9	13.0	
	Intermittent (3 x 441-480 V) [A]	3.0	3.4	4.7	6.3	8.1	10.9	14.3	
Additional specifications									
Estimated power loss at rated max. load [W] ⁴⁾ (mains, motor, brake) [[mm ² /AWG] ²⁾	58	62	88	116	124	187	255		
Weight enclosure IP20 [kg]	4/10								
Weight enclosure IP 21 [kg]	4.8	4.9	4.9	4.9	4.9	6.6	6.6	6.6	
Weight enclosure IP 55 [kg] (A4/A5)	9.7/13.5 9.7/13.5 9.7/13.5 9.7/13.5 9.7/13.5 9.7/13.5								
Weight enclosure IP 66 [kg] (A4/A5)	9.7/13.5 9.7/13.5 9.7/13.5 9.7/13.5 9.7/13.5 9.7/13.5								
Efficiency ³⁾	0.96	0.97	0.97	0.97	0.97	0.97	0.97	0.97	

Table 10.3 Mains Supply 3 x 380 - 480 VAC

Mains Supply 3 x 380 - 480 VAC - Normal overload 110% for 1 minute												
Frequency converter	P11K	P15K	P18K	P22K	P30K	P37K	P45K	P55K	P75K	P90K		
Typical Shaft Output [kW]	11	15	18.5	22	30	37	45	55	75	90		
Typical Shaft Output [HP] at 460 V	15	20	25	30	40	50	60	75	100	125		
IP20/Chassis (B3+4 and C3+4 may be converted to IP21 using a conversion kit (Please contact Danfoss))	B3	B3	B3	B4	B4	B4	C3	C3	C4	C4		
IP21/NEMA 1	B1	B1	B1	B2	B2	C1	C1	C1	C2	C2		
IP55/NEMA 12	B1	B1	B1	B2	B2	C1	C1	C1	C2	C2		
IP66/NEMA 12	B1	B1	B1	B2	B2	C1	C1	C1	C2	C2		
Output current												
	Continuous (3 x 380-439 V) [A]			44	61	73	90	106	147	177		
	Intermittent (3 x 380-439 V) [A]			48.4	67.1	80.3	99	117	162	195		
	Continuous (3 x 440-480 V) [A]			40	52	65	80	105	130	160		
	Intermittent (3 x 440-480 V) [A]			44	61.6	71.5	88	116	143	176		
	Continuous kVA (400 V AC) [kVA]			30.5	42.3	50.6	62.4	73.4	102	123		
Continuous kVA 460 V AC [kVA]			16.7	21.5	27.1	31.9	41.4	63.7	83.7	104	128	
Max. input current												
	Continuous (3 x 380-439 V) [A]			40	55	66	82	96	133	161		
	Intermittent (3 x 380-439 V) [A]			44	60.5	72.6	90.2	106	146	177		
	Continuous (3 x 440-480 V) [A]			36	47	59	73	95	118	145		
	Intermittent (3 x 440-480 V) [A]			39.6	51.7	64.9	80.3	105	130	160		
Additional specifications												
Estimated power loss at rated max. load [W]			525	698	739	843	1083	1384	1474			
Max. cable size (mains, motor, brake) [mm ² /AWG] ²⁾			35/2			50/1/0 (B4=35/2)			95/4/0	120/MCM250		
With mains disconnect switch included:			16/6			35/2			70/3/0	185/kcmil350		
Weight enclosure IP20 [kg]			12	12	12	23.5	35	35	50	50		
Weight enclosure IP21 [kg]			23	23	23	27	45	45	65	65		
Weight enclosure IP55 [kg]			23	23	23	27	45	45	65	65		
Weight enclosure IP66 [kg]			23	23	23	27	45	45	65	65		
Efficiency ³⁾			0.98	0.98	0.98	0.98	0.98	0.98	0.98	0.98	0.99	

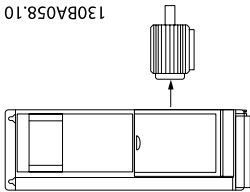
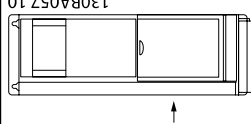
Table 10.4 Mains Supply 3 x 380 - 480 VAC

Mains supply 3 x 525 - 600 VAC Normal overload 110% for 1 minute																		
Size:	P1K1	PTK5	P2K2	P3K0	P3K7	P4K0	P5K5	P7K5	P11K	P15K	P18K	P22K	P30K	P37K	P45K	P55K	P75K	P90K
Typical Shaft Output [kW]	1.1	1.5	2.2	3	3.7	4	5.5	7.5	11	15	18.5	22	30	37	45	55	75	90
IP20/Chassis	A3	A3	A3	A3	A2	A3	A3	A3	B3	B3	B3	B4	B4	B4	C3	C3	C4	C4
IP21/NEMA 1	A3	A3	A3	A3	A2	A3	A3	A3	B1	B1	B1	B2	B2	C1	C1	C1	C2	C2
IP55/NEMA 12	A5	A5	A5	A5	A5	A5	A5	A5	B1	B1	B1	B2	B2	C1	C1	C1	C2	C2
IP66/NEMA 12	A5	A5	A5	A5	A5	A5	A5	A5	B1	B1	B1	B2	B2	C1	C1	C1	C2	C2
Output current																		
	Continuous (3 x 525-550V) [A]																	
	Intermittent (3 x 525-550V) [A]																	
	Continuous (3 x 525-600V) [A]																	
	Intermittent (3 x 525-600V) [A]																	
	Continuous kVA (525V AC) [kVA]																	
Continuous kVA (575V AC) [kVA]																		
Max. input current																		
Continuous (3 x 525-600V) [A]																124.3		
Intermittent (3 x 525-600V) [A]																137		
Additional specifications																		
Estim. power loss at rated max. load [W] ⁴⁾																	1500	
Max. cable size, IP21/55/66 (mains, motor, brake) [mm ²]/[AWG] ²⁾																	120/MCM250	
Mains disconnect switch included:																	150/MCM250 ⁵⁾	
Weight IP20 [kg]																	185/kcmil350	
Weight IP21/55 [kg]																	50	
Efficiency ⁴⁾																	65	

Table 10.5 ⁵⁾ With brake and load sharing 95/ 4/0

10.2 General Technical Data

Mains supply (L1, L2, L3):

Supply voltage	200-240V ±10%, 380-480V ±10%, 525-690V ±10%
----------------	---

Mains voltage low / mains drop-out:

During low mains voltage or a mains drop-out, the FC continues until the intermediate circuit voltage drops below the minimum stop level, which corresponds typically to 15% below the FC's lowest rated supply voltage. Power-up and full torque cannot be expected at mains voltage lower than 10% below the FC's lowest rated supply voltage.

Supply frequency	50/60Hz ±5%
Max. imbalance temporary between mains phases	3.0% of rated supply voltage
True Power Factor ()	≥ 0.9 nominal at rated load
Displacement Power Factor (cos) near unity	(> 0.98)
Switching on input supply L1, L2, L3 (power-ups) ≤ enclosure type A	maximum twice/min.
Switching on input supply L1, L2, L3 (power-ups) ≥ enclosure type B, C	maximum once/min.
Switching on input supply L1, L2, L3 (power-ups) ≥ enclosure type D, E, F	maximum once/2 min.
Environment according to EN60664-1	overvoltage category III / pollution degree 2

The unit is suitable for use on a circuit capable of delivering not more than 100.000 RMS symmetrical Amperes, 480/600 V maximum.

Motor output (U, V, W):

Output voltage	0 - 100% of supply voltage
Output frequency	0 - 1000 Hz*
Switching on output	Unlimited
Ramp times	1 - 3600 sec.

* Dependent on power size.

Torque characteristics:

Starting torque (Constant torque)	maximum 110% for 1 min.*
Starting torque	maximum 135% up to 0.5 sec.*
Overload torque (Constant torque)	maximum 110% for 1 min.*

*Percentage relates to the frequency converter's nominal torque.

Cable lengths and cross sections:

Max. motor cable length, screened/armoured	VLT HVAC Drive: 150 m
Max. motor cable length, unscreened/unarmoured	VLT HVAC Drive: 300 m
Max. cross section to motor, mains, load sharing and brake *	
Maximum cross section to control terminals, rigid wire	1.5 mm ² /16 AWG (2 x 0.75 mm ²)
Maximum cross section to control terminals, flexible cable	1 mm ² /18 AWG
Maximum cross section to control terminals, cable with enclosed core	0.5 mm ² /20 AWG
Minimum cross section to control terminals	0.25 mm ²

* See 10.1 Power-dependent Specifications for more information!

Digital inputs:

Programmable digital inputs	4 (6)
Terminal number	18, 19, 27 ¹⁾ , 29 ¹⁾ , 32, 33,
Logic	PNP or NPN
Voltage level	0 - 24V DC
Voltage level, logic '0' PNP	< 5V DC
Voltage level, logic '1' PNP	> 10V DC
Voltage level, logic '0' NPN	> 19 V DC
Voltage level, logic '1' NPN	< 14V DC
Maximum voltage on input	28V DC
Input resistance, R _i	approx. 4kΩ

All digital inputs are galvanically isolated from the supply voltage (PELV) and other high-voltage terminals.

1) Terminals 27 and 29 can also be programmed as output.

Analog inputs:

Number of analog inputs	2
Terminal number	53, 54
Modes	Voltage or current
Mode select	Switches A53 and A54
Voltage mode	Switch A53/A54 = (U)
Voltage level	0 to + 10V (scaleable)
Input resistance, R_i	approx. 10 k Ω
Max. voltage	\pm 20 V
Current mode	Switch A53/A54 = (I)
Current level	0/4 to 20 mA (scaleable)
Input resistance, R_i	approx. 200 Ω
Max. current	30 mA
Resolution for analog inputs	10 bit (+ sign)
Accuracy of analog inputs	Max. error 0.5% of full scale
Bandwidth	200Hz

The analog inputs are galvanically isolated from the supply voltage (PELV) and other high-voltage terminals.

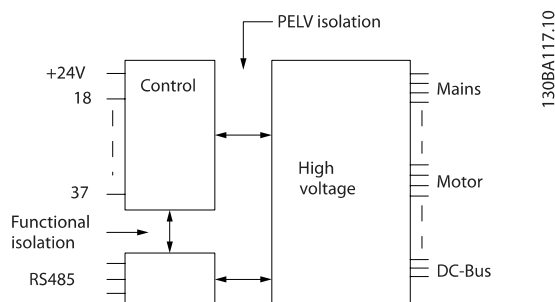
10
Pulse inputs:

Programmable pulse inputs	2
Terminal number pulse	29, 33
Max. frequency at terminal, 29, 33	110 kHz (Push-pull driven)
Max. frequency at terminal, 29, 33	5 kHz (open collector)
Min. frequency at terminal 29, 33	4 Hz
Voltage level	see section on Digital input
Maximum voltage on input	28 V DC
Input resistance, R_i	approx. 4 k Ω
Pulse input accuracy (0.1 - 1 kHz)	Max. error: 0.1% of full scale

Analog output:

Number of programmable analog outputs	1
Terminal number	42
Current range at analog output	0/4 - 20 mA
Max. resistor load to common at analog output	500 Ω
Accuracy on analog output	Max. error: 0.8 % of full scale
Resolution on analog output	8 bit

The analog output is galvanically isolated from the supply voltage (PELV) and other high-voltage terminals.

Control card, RS-485 serial communication:

Terminal number	68 (P,TX+, RX+), 69 (N,TX-, RX-)
Terminal number 61	Common for terminals 68 and 69

The RS-485 serial communication circuit is functionally seated from other central circuits and galvanically isolated from the supply voltage (PELV).

Digital output:

Programmable digital/pulse outputs	2
Terminal number	27, 29 ¹⁾
Voltage level at digital/frequency output	0 - 24 V
Max. output current (sink or source)	40 mA
Max. load at frequency output	1 kΩ
Max. capacitive load at frequency output	10 nF
Minimum output frequency at frequency output	0 Hz
Maximum output frequency at frequency output	32 kHz
Accuracy of frequency output	Max. error: 0.1 % of full scale
Resolution of frequency outputs	12 bit

1) Terminal 27 and 29 can also be programmed as input.

The digital output is galvanically isolated from the supply voltage (PELV) and other high-voltage terminals.

Control card, 24 V DC output:

Terminal number	12, 13
Max. load	200mA

The 24 V DC supply is galvanically isolated from the supply voltage (PELV), but has the same potential as the analog and digital inputs and outputs.

Relay outputs:

Programmable relay outputs	2
Relay 01 Terminal number	1-3 (break), 1-2 (make)
Max. terminal load (AC-1) ¹⁾ on 1-3 (NC), 1-2 (NO) (Resistive load)	240V AC, 2A
Max. terminal load (AC-15) ¹⁾ (Inductive load @ cosφ 0.4)	240V AC, 0.2A
Max. terminal load (DC-1) ¹⁾ on 1-2 (NO), 1-3 (NC) (Resistive load)	60V DC, 1A
Max. terminal load (DC-13) ¹⁾ (Inductive load)	24V DC, 0.1A
Relay 02 Terminal number	4-6 (break), 4-5 (make)
Max. terminal load (AC-1) ¹⁾ on 4-5 (NO) (Resistive load) ²⁾³⁾	400V AC, 2A
Max. terminal load (AC-15) ¹⁾ on 4-5 (NO) (Inductive load @ cosφ 0.4)	240V AC, 0.2A
Max. terminal load (DC-1) ¹⁾ on 4-5 (NO) (Resistive load)	80V DC, 2A
Max. terminal load (DC-13) ¹⁾ on 4-5 (NO) (Inductive load)	24V DC, 0.1A
Max. terminal load (AC-1) ¹⁾ on 4-6 (NC) (Resistive load)	240V AC, 2A
Max. terminal load (AC-15) ¹⁾ on 4-6 (NC) (Inductive load @ cosφ 0.4)	240V AC, 0.2A
Max. terminal load (DC-1) ¹⁾ on 4-6 (NC) (Resistive load)	50V DC, 2A
Max. terminal load (DC-13) ¹⁾ on 4-6 (NC) (Inductive load)	24V DC, 0.1A
Min. terminal load on 1-3 (NC), 1-2 (NO), 4-6 (NC), 4-5 (NO)	24V DC 10mA, 24V AC 2 mA
Environment according to EN 60664-1	overvoltage category III/pollution degree 2

1) IEC 60947 t 4 and 5

The relay contacts are galvanically isolated from the rest of the circuit by reinforced isolation (PELV).

2) Overvoltage Category II

3) UL applications 300V AC 2A

Control card, 10 V DC output:

Terminal number	50
Output voltage	10.5 V ±0.5 V
Max. load	25 mA

The 10 V DC supply is galvanically isolated from the supply voltage (PELV) and other high-voltage terminals.

Control characteristics:

Resolution of output frequency at 0 - 1000 Hz	+/- 0.003 Hz
System response time (terminals 18, 19, 27, 29, 32, 33)	≤ 2 ms
Speed control range (open loop)	1:100 of synchronous speed
Speed accuracy (open loop)	30 - 4000 rpm: Maximum error of ±8 rpm

All control characteristics are based on a 4-pole asynchronous motor

Surroundings:

Enclosure type A	IP 20/Chassis, IP 21kit/Type 1, IP55/Type12, IP 66/Type12
Enclosure type B1/B2	IP 21/Type 1, IP55/Type12, IP 66/12
Enclosure type B3/B4	IP20/Chassis
Enclosure type C1/C2	IP 21/Type 1, IP55/Type 12, IP66/12
Enclosure type C3/C4	IP20/Chassis
Enclosure type D1/D2/E1	IP21/Type 1, IP54/Type12
Enclosure type D3/D4/E2	IP00/Chassis
Enclosure type F1/F3	IP21, 54/Type1, 12
Enclosure type F2/F4	IP21, 54/Type1, 12
Enclosure kit available ≤ enclosure type D	IP21/NEMA 1/IP 4x on top of enclosure
Vibration test all enclosure types	1.0g
Relative humidity	5% - 95% (IEC 721-3-3; Class 3K3 (non-condensing) during operation
Aggressive environment (IEC 60068-2-43) H ₂ S test	class Kd
Test method according to IEC 60068-2-43 H ₂ S (10 days)	
Ambient temperature (at 60 AVM switching mode)	
- with derating	max. 55°C ¹⁾
- with full output power of typical EFF2 motors (up to 90% output current)	max. 50 °C ¹⁾
- at full continuous FC output current	max. 45 °C ¹⁾

¹⁾ For more information on derating see the Design Guide, section on Special Conditions.

Minimum ambient temperature during full-scale operation	0°C
Minimum ambient temperature at reduced performance	- 10°C
Temperature during storage/transport	-25 - +65/70°C
Maximum altitude above sea level without derating	1000m
Maximum altitude above sea level with derating	3000m

Derating for high altitude, see section on special conditions

EMC standards, Emission	EN 61800-3, EN 61000-6-3/4, EN 55011, IEC 61800-3 EN 61800-3, EN 61000-6-1/2,
EMC standards, Immunity	EN 61000-4-2, EN 61000-4-3, EN 61000-4-4, EN 61000-4-5, EN 61000-4-6

See section on special conditions!

Control card performance:

Scan interval	5 ms
---------------	------

Control card, USB Serial Communication:

USB standard	1.1 (Full speed)
USB plug	USB type B "device" plug



Connection to PC is carried out via a standard host/device USB cable.

The USB connection is galvanically isolated from the supply voltage (PELV) and other high-voltage terminals.

The USB connection is not galvanically isolated from protection earth. Use only isolated laptop/PC as connection to the USB connector on frequency converter or an isolated USB cable/converter.

Protection and Features:

- Electronic thermal motor protection against overload.
- Temperature monitoring of the heatsink ensures that the frequency converter trips if the temperature reaches $95^{\circ}\text{C} \pm 5^{\circ}\text{C}$. An overload temperature cannot be reset until the temperature of the heatsink is below $70^{\circ}\text{C} \pm 5^{\circ}\text{C}$ (Guideline - these temperatures may vary for different power sizes, enclosures etc.). The frequency converter has an auto derating function to avoid it's heatsink reaching 95°C .
- The frequency converter is protected against short-circuits on motor terminals U, V, W.
- If a mains phase is missing, the frequency converter trips or issues a warning (depending on the load).
- Monitoring of the intermediate circuit voltage ensures that the frequency converter trips if the intermediate circuit voltage is too low or too high.
- The frequency converter is protected against earth faults on motor terminals U, V, W.

10.3 Fuse Tables

10.3.1 Branch Circuit Protection Fuses

For compliance with IEC/EN 61800-5-1 electrical standards the following fuses are recommended.

Frequency converter	Maximum fuse size	Voltage	Type
200-240 V - T2			
1K1-1K5	16A ¹	200-240	type gG
2K2	25A ¹	200-240	type gG
3K0	25A ¹	200-240	type gG
3K7	35A ¹	200-240	type gG
5K5	50A ¹	200-240	type gG
7K5	63A ¹	200-240	type gG
11K	63A ¹	200-240	type gG
15K	80A ¹	200-240	type gG
18K5	125A ¹	200-240	type gG
22K	125A ¹	200-240	type gG
30K	160A ¹	200-240	type gG
37K	200A ¹	200-240	type aR
45K	250A ¹	200-240	type aR
380-480 V - T4			
1K1-1K5	10A ¹	380-500	type gG
2K2-3K0	16A ¹	380-500	type gG
4K0-5K5	25A ¹	380-500	type gG
7K5	35A ¹	380-500	type gG
11K-15K	63A ¹	380-500	type gG
18K	63A ¹	380-500	type gG
22K	63A ¹	380-500	type gG
30K	80A ¹	380-500	type gG
37K	100A ¹	380-500	type gG
45K	125A ¹	380-500	type gG
55K	160A ¹	380-500	type gG
75K	250A ¹	380-500	type aR
90K	250A ¹	380-500	type aR
1) Max. fuses - see national/international regulations for selecting an applicable fuse size.			

Table 10.6 EN50178 fuses 200 V to 480 V

10.3.2 UL and cUL Branch Circuit Protection Fuses

For compliance with UL and cUL electrical standards the following fuses or UL/cUL approved substitutions are required. Maximum fuse ratings are listed.

Frequency converter	Bussmann	Bussmann	Bussmann	SIBA	Littel fuse	Ferraz-Shawmut	Ferraz-Shawmut
200-240 V							
kW	Type RK1	Type J	Type T	Type RK1	Type RK1	Type CC	Type RK1
K25-K37	KTN-R05	JKS-05	JJN-05	5017906-005	KLN-R005	ATM-R05	A2K-05R
K55-1K1	KTN-R10	JKS-10	JJN-10	5017906-010	KLN-R10	ATM-R10	A2K-10R
1K5	KTN-R15	JKS-15	JJN-15	5017906-015	KLN-R15	ATM-R15	A2K-15R
2K2	KTN-R20	JKS-20	JJN-20	5012406-020	KLN-R20	ATM-R20	A2K-20R
3K0	KTN-R25	JKS-25	JJN-25	5012406-025	KLN-R25	ATM-R25	A2K-25R
3K7	KTN-R30	JKS-30	JJN-30	5012406-030	KLN-R30	ATM-R30	A2K-30R
5K5	KTN-R50	JKS-50	JJN-50	5012406-050	KLN-R50	-	A2K-50R
7K5	KTN-R50	JKS-60	JJN-60	5012406-050	KLN-R60	-	A2K-50R
11K	KTN-R60	JKS-60	JJN-60	5014006-063	KLN-R60	A2K-60R	A2K-60R
15K	KTN-R80	JKS-80	JJN-80	5014006-080	KLN-R80	A2K-80R	A2K-80R
18K5	KTN-R125	JKS-150	JJN-125	2028220-125	KLN-R125	A2K-125R	A2K-125R
22K	KTN-R125	JKS-150	JJN-125	2028220-125	KLN-R125	A2K-125R	A2K-125R
30K	FWX-150	-	-	2028220-150	L25S-150	A25X-150	A25X-150
37K	FWX-200	-	-	2028220-200	L25S-200	A25X-200	A25X-200
45K	FWX-250	-	-	2028220-250	L25S-250	A25X-250	A25X-250
380-480 V, 525-600 V							
kW	Type RK1	Type J	Type T	Type RK1	Type RK1	Type CC	Type RK1
K37-1K1	KTS-R6	JKS-6	JJS-6	5017906-006	KLS-R6	ATM-R6	A6K-6R
1K5-2K2	KTS-R10	JKS-10	JJS-10	5017906-010	KLS-R10	ATM-R10	A6K-10R
3K0	KTS-R15	JKS-15	JJS-15	5017906-016	KLS-R16	ATM-R16	A6K-16R
4K0	KTS-R20	JKS-20	JJS-20	5017906-020	KLS-R20	ATM-R20	A6K-20R
5K5	KTS-R25	JKS-25	JJS-25	5017906-025	KLS-R25	ATM-R25	A6K-25R
7K5	KTS-R30	JKS-30	JJS-30	5012406-032	KLS-R30	ATM-R30	A6K-30R
11K	KTS-R40	JKS-40	JJS-40	5014006-040	KLS-R40	-	A6K-40R
15K	KTS-R40	JKS-40	JJS-40	5014006-040	KLS-R40	-	A6K-40R
18K	KTS-R50	JKS-50	JJS-50	5014006-050	KLS-R50	-	A6K-50R
22K	KTS-R60	JKS-60	JJS-60	5014006-063	KLS-R60	-	A6K-60R
30K	KTS-R80	JKS-80	JJS-80	2028220-100	KLS-R80	-	A6K-80R
37K	KTS-R100	JKS-100	JJS-100	2028220-125	KLS-R100		A6K-100R
45K	KTS-R125	JKS-150	JJS-150	2028220-125	KLS-R125		A6K-125R
55K	KTS-R150	JKS-150	JJS-150	2028220-160	KLS-R150		A6K-150R
75K	FWH-220	-	-	2028220-200	L50S-225		A50-P225
90K	FWH-250	-	-	2028220-250	L50S-250		A50-P250

Table 10.7 UL fuses, 200 - 240 V and 380 - 600 V

10.3.3 Substitute Fuses for 240 V

Original fuse	Manufacturer	Substitute fuses
KTN	Bussmann	KTS
FWX	Bussmann	FWH
KLNR	LITTEL FUSE	KLSR
L50S	LITTEL FUSE	L50S
A2KR	FERRAZ SHAWMUT	A6KR
A25X	FERRAZ SHAWMUT	A50X

10.4 Connection Tightening Torques

Enclosure	Power (kW)			Torque (Nm)					
	200-240V	380-480V	525-600V	Mains	Motor	DC connection	Brake	Earth	Relay
A2	1.1 - 3.0	1.1 - 4.0	1.1 - 4.0	1.8	1.8	1.8	1.8	3	0.6
A3	3.7	5.5 - 7.5	5.5 - 7.5	1.8	1.8	1.8	1.8	3	0.6
A4	1.1 - 2.2	1.1 - 4.0		1.8	1.8	1.8	1.8	3	0.6
A5	1.1 - 3.7	1.1 - 7.5	1.1 - 7.5	1.8	1.8	1.8	1.8	3	0.6
B1	5.5 - 11	11 - 18.5	11 - 18.5	1.8	1.8	1.5	1.5	3	0.6
B2	-	22	22	4.5	4.5	3.7	3.7	3	0.6
	15	30	30	4.5 ²⁾	4.5 ²⁾	3.7	3.7	3	0.6
B3	5.5 - 11	11 - 18.5	11 - 18.5	1.8	1.8	1.8	1.8	3	0.6
B4	15 - 18.5	22 - 37	22 - 37	4.5	4.5	4.5	4.5	3	0.6
C1	18.5 - 30	37 - 55	37 - 55	10	10	10	10	3	0.6
C2	37 - 45	75 - 90	75 - 90	14/24 ¹⁾	14/24 ¹⁾	14	14	3	0.6
C3	22 - 30	45 - 55	45 - 55	10	10	10	10	3	0.6
C4	37 - 45	75 - 90	75 - 90	14/24 ¹⁾	14/24 ¹⁾	14	14	3	0.6

Table 10.8 Tightening of terminals

- 1) For different cable dimensions x/y, where $x \leq 95\text{mm}^2$ and $y \geq 95\text{mm}^2$.
- 2) Cable dimensions above $18.5\text{kW} \geq 35\text{mm}^2$ and below $22\text{kW} \leq 10\text{mm}^2$.

Index

A
A53..... 18
A54..... 18
AC
 Input..... 6, 15
 Mains..... 6, 10, 15
 Waveform..... 6
Alarm Log..... 32, 30
Alarm/Warning Code List..... 57
Alarms..... 55
Analog
 Inputs..... 16, 57, 72
 Output..... 16, 72
Application Examples..... 48
Approvals..... 1
Auto
 Mode..... 30
 On..... 31, 52, 54
Automatic Motor Adaptation..... 26, 52
Auto-reset..... 29
AWG..... 66

B
Back Plate..... 9
Braking..... 60, 52

C
Cable Lengths And Cross Sections..... 71
Circuit Breakers..... 24
Clearance
 Clearance..... 60, 8
 Requirements..... 8
Closed Loop..... 18
Communication Option..... 60
Conduit..... 12, 24, 15
Control
 Cables..... 18
 Card Performance..... 74
 Card, 10 V DC Output..... 73
 Card, 24 V DC Output..... 73
 Card, RS-485 Serial Communication..... 72
 Card, USB Serial Communication..... 74
 Characteristics..... 73
 Signal..... 33, 34, 52
 System..... 5, 6
 Terminals..... 10, 26, 31, 52, 54, 71, 34, 17
 Wire..... 17
 Wiring..... 12, 13, 17, 24, 15
Cooling
 Cooling..... 8
 Clearance..... 24

Copying Parameter Settings..... 31
Current
 Limit..... 27, 59, 61
 Rating..... 8, 58

D
Danfoss FC..... 22
DC
 Current..... 6, 53
 Link..... 58
Derating..... 58, 74, 75, 8
Digital
 Input..... 54, 59, 18
 Inputs..... 16, 54, 71, 35
 Output..... 73
Disconnect
 Switch..... 25
 Switches..... 23

E
Electrical Noise..... 13
EMC..... 24, 59, 74
EN50178 Fuses 200 V To 480 V..... 76
External
 Commands..... 6, 52
 Controllers..... 6
 Interlock..... 18, 35, 61, 49
 Voltage..... 34

F
Fault
 Log..... 30, 32
 Messages..... 57
Feedback..... 18, 24, 61, 48, 53, 62
Floating Delta..... 15
Full Load Current..... 8, 23
Functional Testing..... 5, 27, 23
Fuses..... 24, 60, 64, 76, 77
Fusing..... 12, 24

G
General Technical Data..... 71
Ground
 Connections..... 13, 24
 Loops..... 18
 Wire..... 13, 24
Grounded Delta..... 15
Grounding
 Grounding..... 13, 14, 15, 23, 24
 Using Conduit..... 13
 Using Shielded Cable..... 13

H
Hand On..... 27, 31, 52
Harmonics..... 6

I
IEC 61800-3..... 15, 74
Induced Voltage..... 12
Initialisation..... 32
Input
 Current..... 15
 Disconnect..... 15
 Power..... 12, 13, 15, 24, 55, 64, 6, 23
 Signal..... 34
 Signals..... 18
 Terminals..... 10, 15, 18, 23, 58
 Voltage..... 25, 55, 58
Installation..... 5, 8, 9, 12, 17, 22, 24, 59, 25
Isolated Mains..... 15

J
Johnson Controls N2* 22

L
Leakage
 Current..... 23, 13
 Current (>3,5 MA)..... 13
Lifting..... 9
Local
 Control..... 29, 31, 52
 Control Panel..... 29
 Mode..... 27
 Operation..... 29
 Start..... 27
Local-control Test..... 27

M
Main Menu..... 33, 30
Mains
 Mains..... 12
 Supply..... 66, 70
 Voltage..... 30, 31, 52, 58, 61, 71
MCT-10..... 47
Menu
 Keys..... 29, 30
 Structure..... 31, 36, 37
Modbus RTU..... 22

Motor
 Cables..... 8, 12, 14, 27
 Current..... 6, 26, 58, 61, 30
 Data..... 26, 27, 32, 59, 58, 61, 26
 Frequency..... 26, 30
 Leads..... 59
 Output..... 71
 Power..... 10, 12, 13, 61, 30
 Protection..... 12, 75
 Rotation..... 27, 30
 Speeds..... 25
 Status..... 6
 Wiring..... 12, 13
 Wiring, And..... 24
Mounting..... 9, 24
Multiple
 Frequency Converters..... 12, 14
 Motors..... 23

N
Navigation Keys..... 25, 33, 52, 29, 31
Noise Isolation..... 12, 24

O
Open Loop..... 18, 33, 73
Operation Keys..... 31
Optional Equipment..... 14, 18, 25, 6
Output
 Current..... 53, 58, 73
 Performance (U, V, W)..... 71
 Signal..... 36
 Terminals..... 10, 23
Overcurrent..... 53
Overload Protection..... 8, 12
Overvoltage..... 27, 58, 71, 53

P
PELV..... 15, 51, 71, 73
Power
 Connections..... 12
 Factor..... 6, 14, 24, 71
Power-dependent..... 66
Pre-start..... 23
Programming
 Programming..... 5, 18, 26, 27, 30, 32, 36, 47, 58, 25, 29, 31, 33
 Example..... 33
Protection And Features..... 75
Pulse Inputs..... 72

Q
Quick
 Menu..... 26, 30, 33, 36, 30
 Set-up..... 26

R

Ramp-down Time..... 27

Ramp-up Time..... 27

RCD..... 13

Reference..... 1, 48, 52, 53, 30, 33

Relay Outputs..... 16, 73

Remote

 Commands..... 6

 Programming..... 47

 Reference..... 53

Reset..... 29, 32, 54, 55, 58, 60, 62, 75, 31

RFI Filter..... 15

RMS Current..... 6

Run

 Command..... 28

 Permissive..... 53

S

Safety Inspection..... 23

Screened Control Cables..... 18

Serial Communication... 6, 10, 16, 18, 31, 32, 52, 53, 54, 59, 55, 22

Set Up..... 30

Setpoint..... 54

Set-up..... 28, 30

Shielded

 Cable..... 8, 12, 24

 Wire..... 12

Siemens FLN®..... 22

Sleep Mode..... 54

Specifications..... 5, 9, 22, 66

Speed Reference..... 18, 28, 34, 52, 49

Start Up..... 5, 32, 33, 23, 24, 64

Status

 Messages..... 52

 Mode..... 52

Stop Command..... 53

Supply Voltage..... 15, 16, 23, 58, 60, 72, 71

Surroundings..... 74

Switching Frequency..... 53, 58

Symbols..... 1

System

 Feedback..... 6

 Monitoring..... 55

 Start Up..... 28

T

Technical Data..... 71

Temperature Limits..... 24

Terminal

 53..... 33, 18, 34

 54..... 18

 Programming..... 18

 Programming Examples..... 34

Thermistor

 Thermistor..... 15, 58, 51

 Control Wiring..... 15

Tightening Of Terminals..... 78

Torque

 Characteristics..... 71

 Limit..... 27, 59

Transient Protection..... 6

Trip

 Trip..... 55

 Function..... 12

Trip-lock..... 55

Troubleshooting..... 5, 57, 64

U

UL Fuses..... 77

V

Voltage Level..... 71

W

Warning

 And Alarm Definitions..... 56

 And Alarm Displays..... 55

 And Alarm Types..... 55

Warnings..... 55

Wire Sizes..... 12, 14