

Contents

1. How to Read the Instruction Manual	3
Copyright, Limitation of Liability and Revision Rights	3
Approvals	4
Symbols	4
2. Safety	5
General Warning	6
Before Commencing Repair Work	6
Special conditions	7
Avoid unintended Start.	7
Safe Stop of the Adjustable Frequency Drive	8
IT Line	8
3. Introduction	11
Type Code String	11
4. Mechanical installation	15
Before starting	15
How to install	16
5. Electrical installation	23
How to connect	23
Line power wiring overview	26
How to connect the motor - foreword	30
Motor wiring overview	32
Motor connection for C1 and C2	35
How to Test Motor and Direction of Rotation.	36
6. How to operate the adjustable frequency drive	43
Ways of Operation	43
How to operate the Graphical LCP (GLCP)	43
How to operate numeric LCP (NLCP)	49
Tips and tricks	54
7. How to program the adjustable frequency drive	57
How to program	57
Initialization to Default Settings	85
Parameter Options	86

Default settings	86
0-** Operation/Display	88
1-** Load/Motor	90
2-** Brakes	91
3-** Reference / Ramps	92
4-** Limits / Warnings	93
5-** Digital In/Out	94
6-** Analog In/Out	96
8-** Comm. and Options	98
9-** Profibus	99
10-**CAN Ser. Com. Bus	100
13-** Smart Logic	101
14-** Special Functions	102
15-** FC Information	103
16-** Data Readouts	105
18-** Data Readouts 2	107
20-** FC Closed-loop	108
21-** Ext. Closed-loop	109
22-** Application Functions	111
23-** Timed Actions	113
25-** Cascade Controller	114
26-** Analog I/O Option MCB 109	116
29-** Water Application Functions	117
31-** Bypass Option	118
8. Troubleshooting	119
	121
9. Specifications	127
General Specifications	127
Line Supply 3 x 200-240 V AC	127
Line Supply 3 x 380-480 V AC	131
Special Conditions	141
Purpose of derating	141
Automatic adaptations to ensure performance	144
Index	145

1. How to Read the Instruction Manual

1.1.1. Copyright, Limitation of Liability and Revision Rights

This publication contains information proprietary to Danfoss A/S. By accepting and using this manual, the user agrees that the information contained herein will be used solely for operating equipment from Danfoss A/S or equipment from other vendors, provided that such equipment is intended for communication with Danfoss equipment over a serial communication link. This publication is protected under the copyright laws of Denmark and most other countries.

Danfoss A/S does not guarantee that a software program produced according to the guidelines provided in this manual will function properly in every physical, hardware or software environment.

Although Danfoss A/S has tested and reviewed the documentation within this manual, Danfoss A/S makes no warranty or representation, neither expressed nor implied, with respect to this documentation, including its quality, performance or fitness for a particular purpose.

In no event shall Danfoss A/S be liable for direct, indirect, special, incidental or consequential damages arising from the use or the inability to use information contained in this manual, even if advised of the possibility of such damages. In particular, Danfoss A/S is not responsible for any costs, including, but not limited to, those incurred as a result of lost profits or revenue, loss of or damages to equipment, loss of computer programs, loss of data, the costs to substitute these, or any claims by third parties.

Danfoss A/S reserves the right to revise this publication at any time and to make changes to its contents without prior notice or any obligation to notify former or present users of such revisions or changes.

This Instruction Manual will introduce all aspects of your VLT AQUA Drive.

Available literature for the VLT AQUA Drive

- The Instruction Manual MG.20.MX.YY provides the necessary information for getting the drive up and running.
- The Design Guide MG.20.NX.YY contains technical information about the drive design and customer applications.
- The Programming Guide MG.20.OX.YY provides information on how to program and includes complete parameter descriptions.

X = Revision number

YY = Language code

Danfoss Drives technical literature is also available online at www.danfoss.com/BusinessAreas/DrivesSolutions/Documentations/Technical+Documentation.

1

1.1.2. Approvals

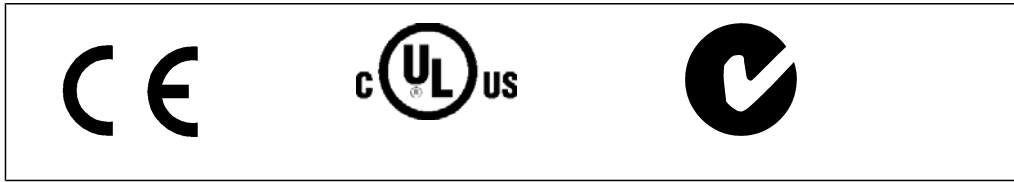

1.1.3. Symbols

Symbols used in this Instruction Manual.

	NOTE Indicates something to be noted by the reader.
--	---

	Indicates a general warning.
--	------------------------------

	Indicates a high-voltage warning.
--	-----------------------------------

*	Indicates a default setting
---	-----------------------------

2. Safety

2.1.1. Safety note



The voltage of the adjustable frequency drive is dangerous whenever connected to line power. Incorrect installation of the motor, adjustable frequency drive or serial communication bus may cause damage to the equipment, serious personal injury or death. Consequently, the instructions in this manual, as well as national and local rules and safety regulations, must be followed.

Safety Regulations

1. The adjustable frequency drive must be disconnected from line power if repair work is to be carried out. Make sure that the line supply has been disconnected and that the necessary time has passed before removing motor and line plugs.
2. The [STOP/RESET] key on the control panel of the adjustable frequency drive does not disconnect the equipment from line power and is thus not to be used as a safety switch.
3. Correct protective grounding of the equipment must be established, the user must be protected against supply voltage, and the motor must be protected against overload in accordance with applicable national and local regulations.
4. The ground leakage currents are higher than 3.5 mA.
5. Protection against motor overload is set by par. 1-90 *Motor Thermal Protection*. If this function is desired, set par. 1-90 to data value [ETR trip] (default value) or data value [ETR warning]. Note: The function is initialized at 1.16 x rated motor current and rated motor frequency. For the North American market: The ETR functions provide class 20 motor overload protection in accordance with NEC.
6. Do not remove the plugs for the motor and line supply while the adjustable frequency drive is connected to line power. Make sure that the line supply has been disconnected and that the necessary time has passed before removing motor and line plugs.
7. Please note that the adjustable frequency drive has more voltage inputs than L1, L2 and L3 when load sharing (linking of the DC intermediate circuit) and external 24 V DC have been installed. Make sure that all voltage inputs have been disconnected and that the necessary time has passed before commencing repair work.

Installation at High Altitudes



At altitudes higher than 6,600 feet [2 km], please contact Danfoss Drives regarding PELV.

Warning against Unintended Start

1. The motor can be brought to a stop by means of digital commands, bus commands, references or a local stop while the adjustable frequency drive is connected to line power. If personal safety considerations make it necessary to ensure that no unintended start occurs, these stop functions are not sufficient.
2. While parameters are being changed, the motor may start. Consequently, the stop key [STOP/RESET] must always be activated, following which data can be modified.
3. A motor that has been stopped may start if faults occur in the electronics of the adjustable frequency drive, or if a temporary overload or a fault in the supply line or the motor connection ceases.

**Warning:**

Touching the electrical parts may be fatal - even after the equipment has been disconnected from line power.

Also, make sure that other voltage inputs have been disconnected, such as external 24 V DC, load sharing (linkage of the DC intermediate circuit), as well as the motor connection for kinetic backup.

2.1.2. General Warning

**Warning:**

Touching the electrical parts may be fatal - even after the equipment has been disconnected from line power.

Also make sure that other voltage inputs have been disconnected (linkage of DC intermediate circuit), as well as the motor connection for kinetic backup.

Before touching any potentially live parts of the VLT AQUA Drive FC 200, wait at least as long as follows:

200-240 V, 0.36-5 hp [0.25-3.7 kW]: wait at least 4 minutes.

200-240 V, 7.5-60 hp [5.5-45 kW]: wait at least 15 minutes.

380-480 V, 0.5-10 hp [0.37-7.5 kW]: wait at least 4 minutes.

380-480 V, 15-125 hp [11-90 kW]: wait at least 15 minutes.

A shorter time is allowed only if indicated on the nameplate for the specific unit.

**Leakage Current**

The ground leakage current from the VLT AQUA Drive FC 200 exceeds 3.5 mA. According to IEC 61800-5-1, a reinforced protective ground connection must be ensured by means of: a min. 0.015 in² [10 mm²] Cu or 0.025 in² [16 mm²] Al PE wire or an additional PE wire, with the same cable cross-section as the line power wiring, must be terminated separately.

Residual Current Device

This product can cause DC current in the protective conductor. If a residual current device (RCD) is used for extra protection, only an RCD of Type B (time delayed) may be used on the supply side of this product. See also RCD Application Note MN.90.GX.02.

Protective grounding of the VLT AQUA Drive FC 200 and the use of RCDs must always follow national and local regulations.

2.1.3. Before Commencing Repair Work

1. Disconnect the adjustable frequency drive from the line power.
2. Disconnect DC bus terminals 88 and 89.
3. Wait at least as long as the time mentioned in section 2.1.2.
4. Remove motor cable.

2.1.4. Special conditions

Electrical ratings:

The rating indicated on the nameplate of the adjustable frequency drive is based on a typical 3-phase line power supply within the specified voltage, current and temperature ranges, which are expected to be used in most applications.

The adjustable frequency drives also support other special applications, which affect the electrical ratings of the adjustable frequency drive.

Special conditions that affect the electrical ratings might be:

- Single phase applications
- High temperature applications which require derating of the electrical ratings
- Marine applications with more severe environmental conditions

Consult the relevant clauses in these instructions and in the **VLT® AQUA Drive Design Guide** for information about the electrical ratings.

Installation requirements:

The overall electrical safety of the adjustable frequency drive requires special installation considerations regarding:

- Fuses and circuit breakers for overcurrent and short-circuit protection
- Selection of power cables (line, motor, brake, load sharing and relay)
- Grid configuration (IT,TN, grounded leg, etc.)
- Safety of low voltage ports (PELV conditions).

Consult the relevant clauses in these instructions and in the **VLT® AQUA Drive Design Guide** for information about the installation requirements.

2.1.5. Caution

The adjustable frequency drive DC link capacitors remain charged after power has been disconnected. To avoid the risk of electrical shock, disconnect the adjustable frequency drive from the line power before performing maintenance procedures. Wait at least as long as follows before servicing the adjustable frequency drive:

Voltage	Min. Waiting Time	
	4 min.	15 min.
200-240 V	0.33-5 hp [0.25-3.7 kW]	7.5-60 hp [5.5-45 kW]
380-480 V	0.5-10 hp [0.37-7.5 kW]	15-125 hp [11-90 kW]

Be aware that there may be high voltage on the DC link even when the LEDs are turned off.

2.1.6. Avoid unintended Start.

While the adjustable frequency drive is connected to line power, the motor can be started/stopped using digital commands, bus commands, references or via the Local Control Panel.

- Disconnect the adjustable frequency drive from line power whenever personal safety considerations make it necessary to avoid unintended start.
- To avoid unintended start, always activate the [OFF] key before changing parameters.
- Unless terminal 37 is turned off, an electronic fault, temporary overload, a fault in the line supply or lost motor connection may cause a stopped motor to start.

2.1.7. Safe Stop of the Adjustable Frequency Drive

For versions fitted with a Safe Stop terminal 37 input, the adjustable frequency drive can perform the safety function *Safe Torque Off* (As defined by draft CD IEC 61800-5-2) or *Stop Category 0* (as defined in EN 60204-1).

It is designed and deemed suitable for the requirements of Safety Category 3 in EN 954-1. This functionality is called Safe Stop. Prior to integrating and using Safe Stop in an installation, a thorough risk analysis must be carried out on the installation in order to determine whether the Safe Stop functionality and safety category are appropriate and sufficient. In order to install and use the Safe Stop function in accordance with the requirements of Safety Category 3 in EN 954-1, the related information and instructions of the VLT AQUA Drive Design Guide MG.20.NX.YY must be followed! The information and instructions contained in the Instruction Manual are not sufficient for a correct and safe use of the Safe Stop functionality!



2.1.8. IT Line



IT Line



Do not connect 400 V adjustable frequency drives with RFI filters to line supplies with a voltage between phase and ground of more than 440 V.

For IT lines and delta ground (grounded leg), line voltage may exceed 440 V between phase and ground.

Par. 14-50 *RFI 1* can be used to disconnect the internal RFI capacitors from the RFI filter to ground. If this is done, it will reduce the RFI performance to A2 level.

2.1.9. Software Version and Approvals: VLT AQUA Drive

VLT AQUA Drive
Instruction Manual
Software version: 1.00

This instruction manual can be used for all VLT AQUA Drive adjustable frequency drives with software version 1.00.
The software version number can be seen in parameter 15-43.

2

2.1.10. Disposal Instructions



Equipment containing electrical components may not be disposed of together with domestic waste.
It must be separately collected with electrical and electronic waste according to local and currently valid legislation.

3. Introduction

3.1. Introduction

3.1.1. Adjustable Frequency Drive Identification

3

Below is an example of an identification label. This label is situated on the adjustable frequency drive and shows the type and the options with which the unit is equipped. See table 2.1 for details of how to read the Type code string (T/C).

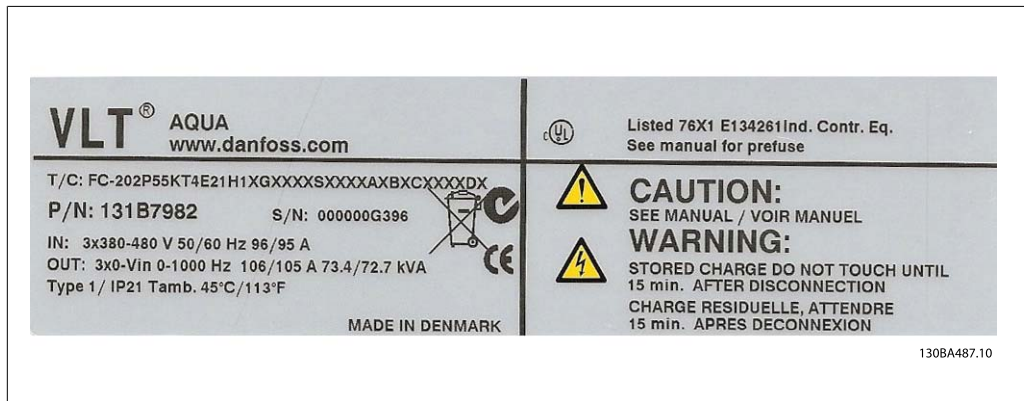

3.1: This example shows an identification label for the VLT AQUA Drive.

Please have T/C (type code) number and serial number ready before contacting Danfoss.

3.1.2. Type Code String

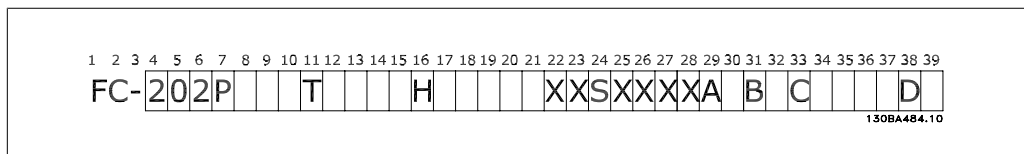

Description	Pos	Possible choice
Product group & VLT Series	1-6	FC 202
Power rating	8-10	0.33-125 hp [0.25-90 kW]
Number of phases	11	Three phases (T)
AC line voltage	11-12	T 2: 200-240 V AC T 4: 380-480 V AC
Enclosure	13-15	E20: IP 20 E21: IP 21/NEMA Type 1 E55: IP 55/NEMA Type 12 E66: IP 66 P21: IP 21/NEMA Type 1 w/backplate P55: IP 55/NEMA Type 12 w/backplate
RFI filter	16-17	H1: RFI filter class A1/B H2: Class A2 H3: RFI filter A1/B (reduced cable length)

Description	Pos	Possible choice
Brake	18	X: No brake chopper included B: Brake chopper included T: Safe Stop U: Safe + brake
Display	19	G: Graphical Local Control Panel (GLCP) N: Numeric Local Control Panel (NLCP) X: No Local Control Panel
Coating PCB	20	X: No coated PCB C: Coated PCB
Line option	21	X: No line power disconnect switch 1: With line power disconnect switch (IP55 only)
Adaptation	22	Reserved
Adaptation	23	Reserved
Software release	24-27	Current software
Software language	28	
A options	29-30	AX: No options A0: MCA 101 Profibus DP V1 A4: MCA 104 DeviceNet AG: MCA 108 LON works
B options	31-32	BX: No option BK: MCB 101 General purpose I/O option BP: MCB 105 Relay option BY: MCO 101 Extended Cascade Control
C0 options MCO	33-34	CX: No options
C1 options	35	X: No options
C option software	36-37	XX: Standard software
D options	38-39	DX: No option D0: DC backup

3.1: Type code description.

The various options are described further in the [VLT AQUA Drive Design Guide](#).

3.1.3. Abbreviations and Standards

Terms:	Abbreviations:	SI units:	I-P units:
Acceleration		m/s ²	ft/s ²
American wire gauge	AWG		
Automatic Motor Tuning	AMT		
Current		A	Amp
Current limit	I _{LIM}		
Energy		J = N·m	ft-lb, Btu
Fahrenheit	°F		
Adjustable Frequency Drive	FC		
Frequency		Hz	Hz
Kilohertz	kHz		
Local Control Panel	LCP		
Milliampere	mA		
Millisecond	ms		
Minute	min		
Motion Control Tool	MCT		
Motor Type Dependent	M-TYPE		
Newton meters	Nm		
Nominal motor current	I _{M,N}		
Nominal motor frequency	f _{M,N}		
Nominal motor power	P _{M,N}		
Nominal motor voltage	U _{M,N}		
Parameter	par.		
Protective Extra Low Voltage	PELV		
Power		W	Btu/hr, hp
Pressure		Pa = N/m ²	psi, psf, ft of water
Rated Inverter Output Current	I _{INV}		
Revolutions Per Minute	RPM		
Size Related	SR		
Temperature		°C	°F
Time		s	s, hr
Torque limit	T _{LIM}		
Voltage		V	V

3.2: Abbreviation and Standards table

4. Mechanical installation

4.1. Before starting

4.1.1. Checklist

When unpacking the adjustable frequency drive, make sure that the unit is undamaged and complete. Use the following table to identify the packaging:

4

Enclosure type:	A2 (IP 20/IP 21)	A3 (IP 20/IP 21)	A5 (IP 55/IP 66)	B1 (IP 21/IP 55/IP 66)	B2 (IP 21/ IP 55/ IP66)	C1 (IP21/IP 55/66)	C2 (IP21/IP 55/66)	
Unit size:								
200-240 V	0.25-3.0 kW	3.7 kW	0.25-3.7 kW	5.5-7.5 kW	11-15 kW	18.5 - 22 kW	30 - 45 kW	
380-480 V	0.37-4.0 kW	7.5-10 hp [5.5-7.5 kW]	0.37-7.5 kW	11-18.5 kW	22-30 kW	37 - 55 kW	75 - 90 kW	





4.1: Unpacking table

Please note that it is recommended to have a selection of screwdrivers (phillips or cross-thread screwdriver and torx), a side-cutter, drill and knife handy for unpacking and mounting the adjustable frequency drive. The packaging for these enclosures contains, as shown: accessories bag (s), documentation and the unit. Depending on options fitted, there may be one or two bags and one or more booklets.

4.2. How to install

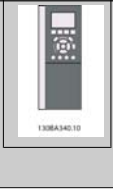
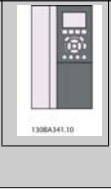
4.2.1. Checklist

Please use the following table for the mounting instructions

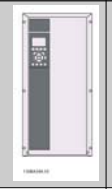
Enclosure:	A2 (IP 20/ IP 21)	A3 (IP 20/ IP 21)	A5 (IP 55/ IP 66)	B1 (IP 21/ IP 55/IP 66)	B2 (IP 21/ IP 55/IP 66)	C1 (IP 21/ IP 55/66)	C2 (IP 21/ IP 55/66)
							
Unit size:							
200-240 V	0.25-3.0 kW	3.7 kW	0.25-3.7 kW	5.5-7.5 kW	11-15 kW	18.5 - 22 kW	30 - 45 kW
380-480 V	0.37-4.0 kW	7.5-10 hp [5.5-7.5 kW]	0.37-7.5 kW	11-18.5 kW	22-30 kW	37 - 55 kW	75 - 90 kW

4.2: Mounting table.

The Danfoss VLT series can be mounted side-by-side for all IP rating units and requires 3.4 in. [100 mm] of free space above and below for cooling. With regard to ambient temperature ratings, please see the Special Conditions.

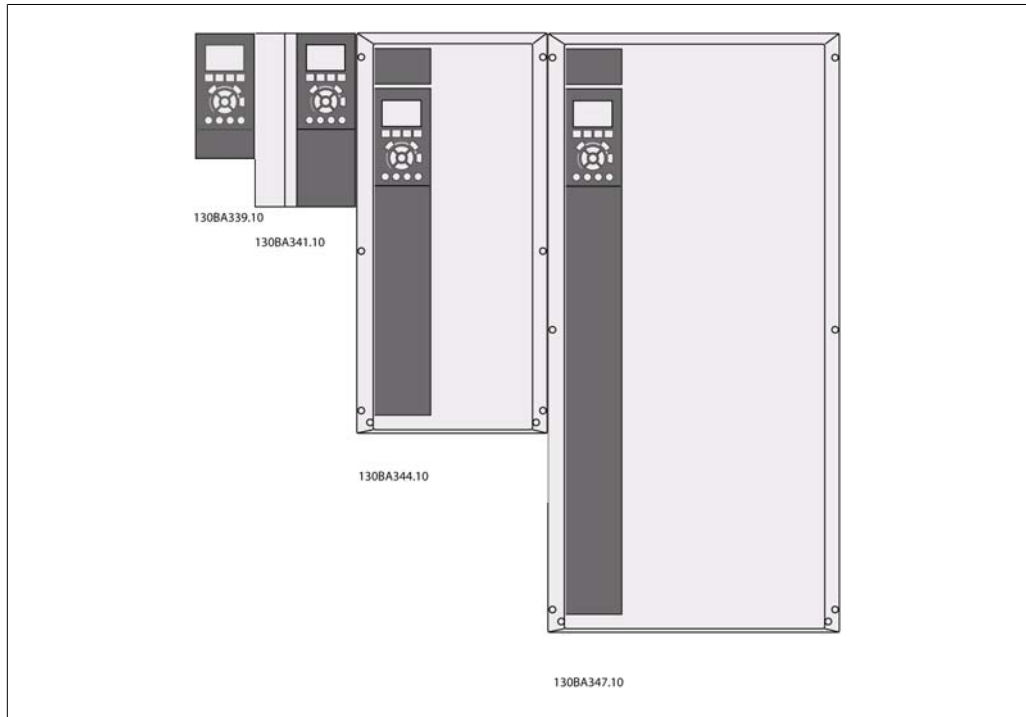

4.1: Side-by-side mounting of all frame sizes.

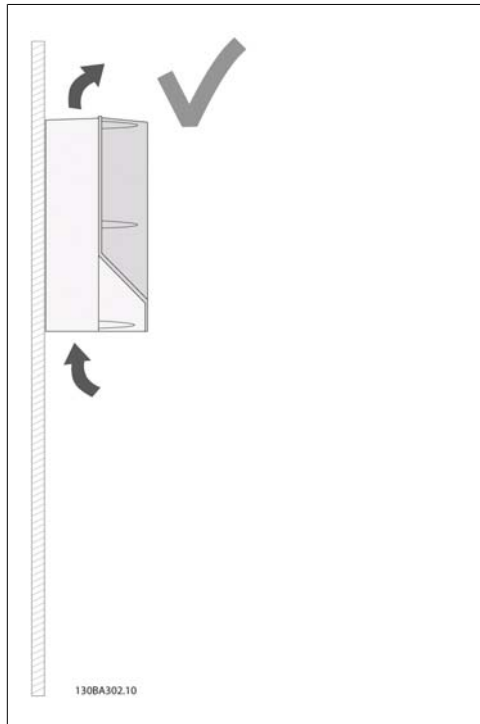

4.2: This is the correct way to mount the unit.

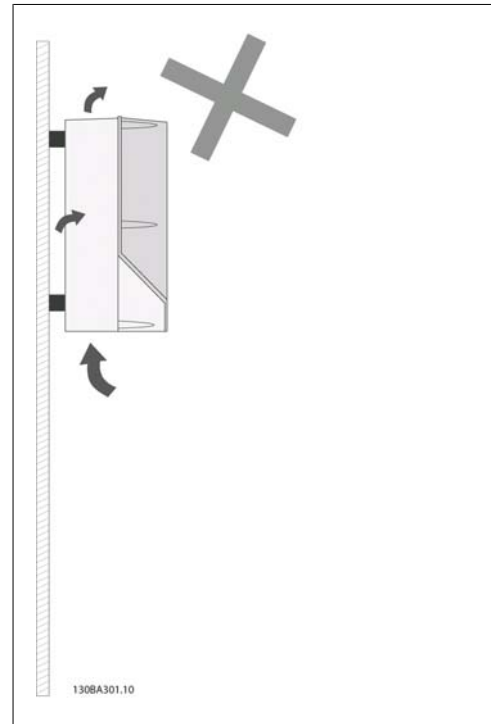

4.3: Other than A2 and A3 enclosures, do not mount units as shown without backplate. Cooling will be insufficient and service life can be drastically shortened.

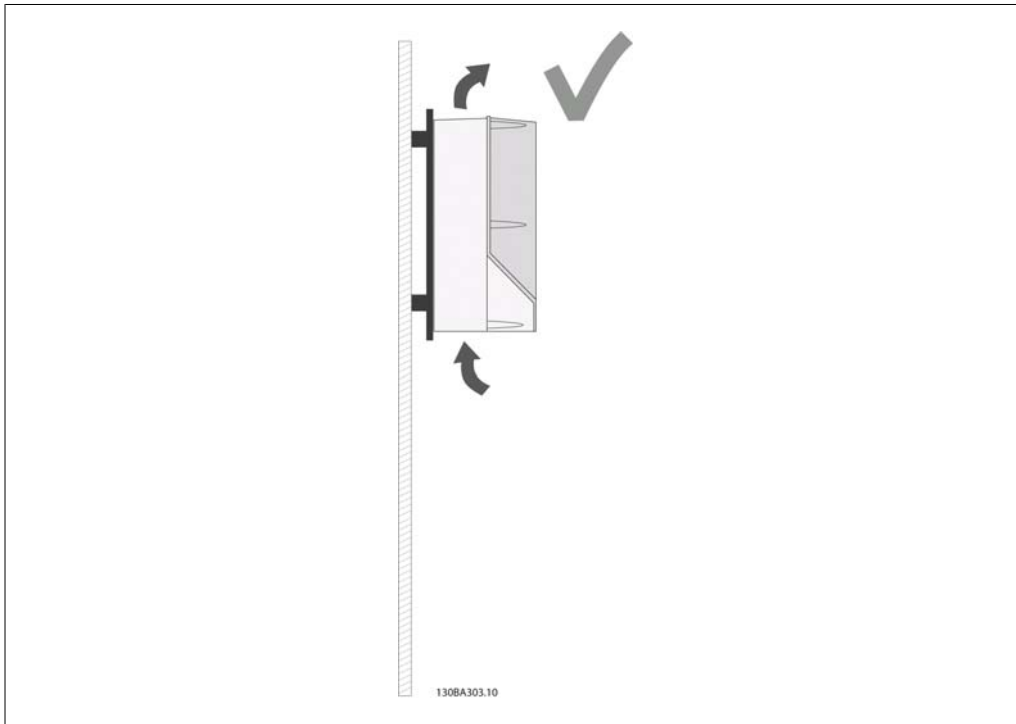

4.4: If the unit must be mounted only a small distance from the wall, please order the backplate with the unit (see Ordering type code position 14-15). A2 and A3 units are equipped with the backplate by default.

4.2.2. Mounting A2 and A3.

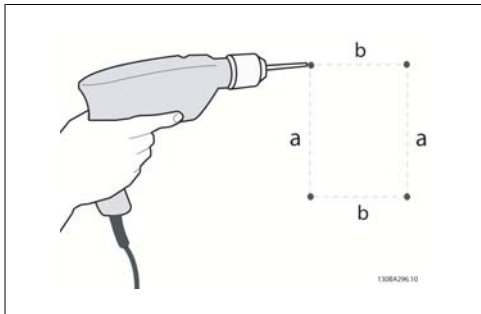

4.5: Drilling of holes

Step 1: Drill according to the dimensions in the following table.

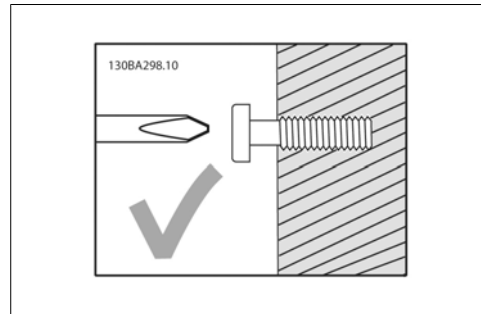

4.6: Correct mounting of screws.

Step 2A: This way it is easy to hang the unit on the screws.

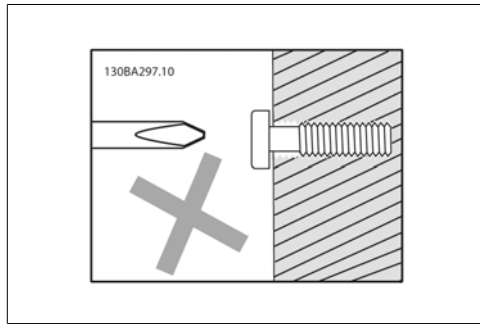

4.7: Incorrect mounting of screws.

Step 2B: Do not tighten screws completely.

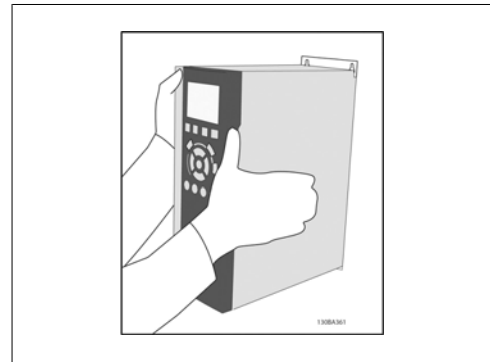

4.8: Mounting of unit.

Step 3: Lift the unit onto the screws.

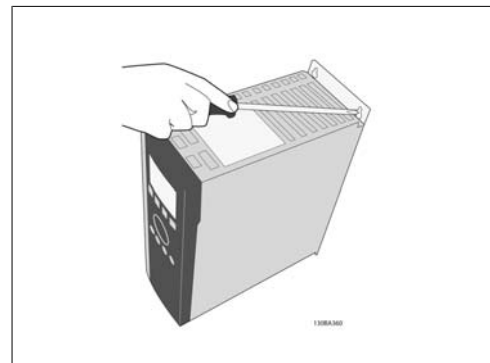

4.9: Tightening of screws

Step 4: Tighten the screws completely.

4

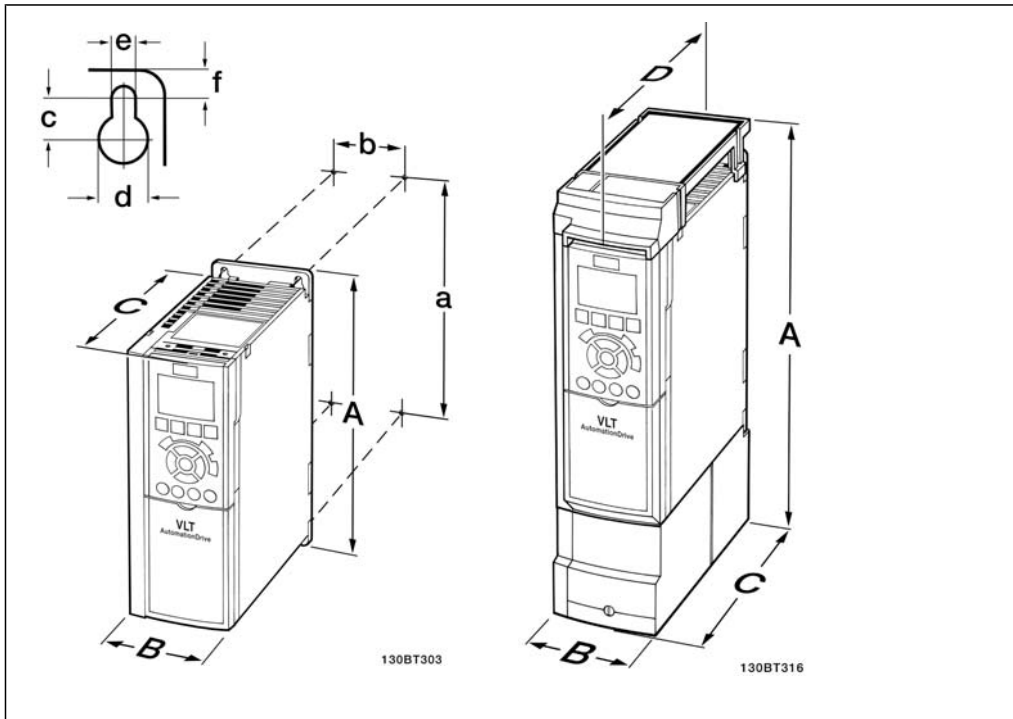

Mechanical dimensions					
Voltage		Frame size A2		Frame size A3	
200-240 V		0.33-4 hp [0.25-3 kW]		5 hp [3.7 kW]	
380-480 V		0.5-5 hp [0.37-4 kW]		7.5-10 hp [5.5-7.5 kW]	
Encapsulation		IP 20	IP 21/Type 1	IP 20	IP 21/Type 1
Height					
Height of backplate	A	10.6 in [268 mm]	1.4 in [375 mm]	10.6 in [268 mm]	1.4 in [375 mm]
Distance between mounting holes	a	10.1 in [257 mm]	13.8 in [350 mm]	10.1 in [257 mm]	13.8 in [350 mm]
Width					
Width of backplate	B	3.5 in [90 mm]	3.5 in [90 mm]	5.1 in [130 mm]	5.1 in [130 mm]
Distance between mounting holes	b	2.8 in [70 mm]	2.8 in [70 mm]	110 mm	4.3 in [110 mm]
Depth					
Depth without option A/B	C	8.01 in [205 mm]	8.01 in [205 mm]	8.01 in [205 mm]	8.01 in [205 mm]
With option A/B	C	8.7 in [220 mm]	8.7 in [220 mm]	8.7 in [220 mm]	8.7 in [220 mm]
Without option A/B	D		8.2 in [207 mm]		8.2 in [207 mm]
With option A/B	D		8.7 in [222 mm]		8.7 in [222 mm]
Screw holes					
	c	0.32 in [8.0 mm]	0.32 in [8.0 mm]	0.32 in [8.0 mm]	0.32 in [8.0 mm]
	d	ø0.43 in [11 mm]	ø0.43 in [11 mm]	ø0.43 in [11 mm]	ø0.43 in [11 mm]
	e	ø0.22 in [5.5 mm]	ø0.22 in [5.5 mm]	ø0.22 in [5.5 mm]	ø0.22 in [5.5 mm]
	f	0.35 in [9 mm]	0.35 in [9 mm]	0.35 in [9 mm]	0.35 in [9 mm]
Maximum weight		10.8 lbs [4.9 kg]	11.7 lbs [5.3 kg]	14.6 lbs [6.6 kg]	15.4 lbs [7.0 kg]

4.3: A2 and A3 mechanical dimensions

NOTE
Options A/B are serial communication and I/O options, which, when fitted, increase the depth of some enclosure sizes.

4.2.3. Mounting A5, B1, B2, C1 and C2.

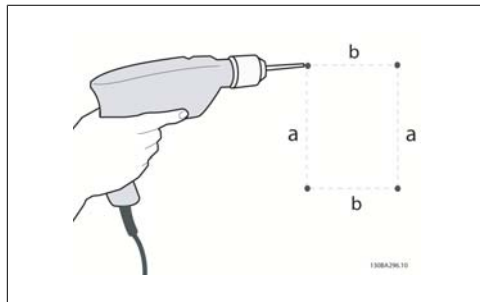

4.10: Drilling holes.

Step 1: Drill according to the dimensions in the following table.

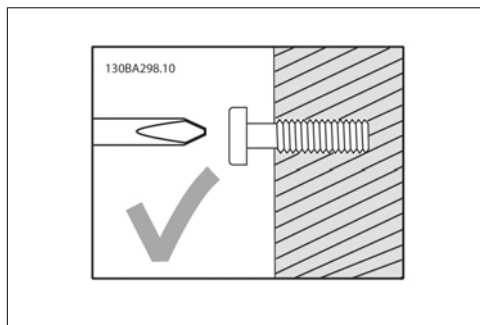

4.11: Correct mounting of screws

Step 2A: This way it is easy to hang the unit on the screws.

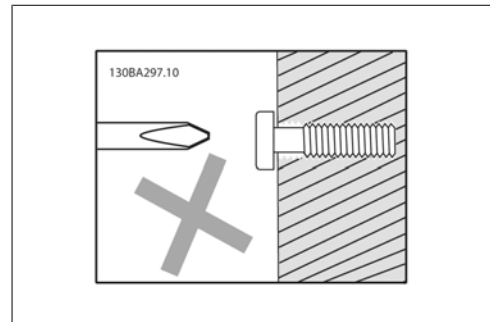

4.12: Incorrect mounting of screws

Step 2B: Do not tighten screws completely.

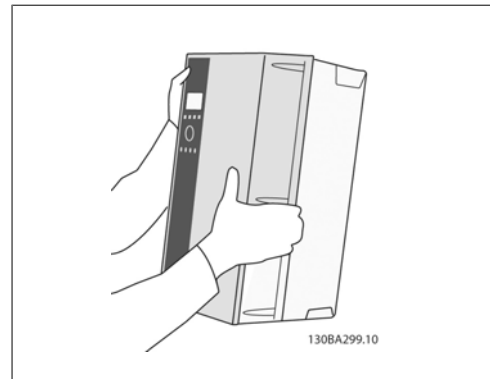

4.13: Mounting of unit.

Step 3: Lift the unit onto the screws.



4.14: Tightening of screws

Step 4: Tighten the screws completely.

4

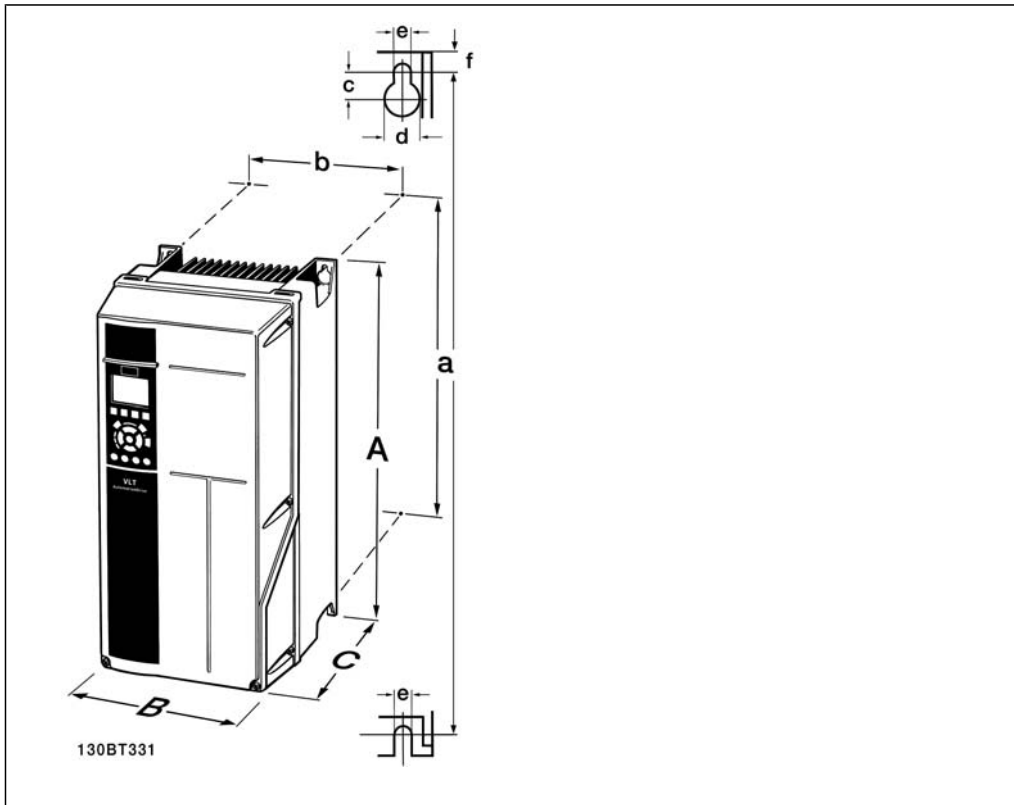

Mechanical dimensions						
Voltage: 200-240 V 380-480 V		Frame size A5 0.33-5 hp [0.25-3.7 kW] 0.5-10 hp [0.37-7.5 kW]	Frame size B1 7.5-10 hp [5.5-7.5 kW] 15-25 hp [11-18.5 kW]	Frame size B2 15-20 hp [11-15 kW] 30-40 hp [22-30 kW]	Frame size C1 25-30 hp [18.5-22 kW] 50-75 hp [37-55 kW]	Frame size C2 40-60 hp [30-45 kW] 100-125-hp [75-90 kW]
Encapsulation		IP 55/66	IP 21/55/66	IP 21/55/66	IP 21/55/66	IP 21/55/66
Height¹⁾						
Height	A	16.5 in [420 mm]	18.9 in [480 mm]	25.6 in [650 mm]	26.8 in [680 mm]	30.3 in [770 mm]
Distance between mounting holes	a	15.8 in [402 mm]	17.9 in [454 mm]	24.6 in [624 mm]	25.5 in [648 mm]	29.1 in [739 mm]
Width¹⁾						
Width	B	9.5 in [242 mm]	9.5 in [242 mm]	9.5 in [242 mm]	12.1 in [308 mm]	14.6 in [370 mm]
Distance between mounting holes	b	8.5 in [215 mm]	8.3 in [210 mm]	8.3 in [210 mm]	10.7 in [272 mm]	13.2 in [334 mm]
Depth						
Depth	C	7.7 in [195 mm]	10.2 in [260 mm]	10.2 in [260 mm]	12.2 in [310 mm]	13.2 in [335 mm]
Screw holes						
	c	0.33 in [8.25 mm]	0.47 in [12 mm]	0.47 in [12 mm]	0.49 in [12.5 mm]	0.49 in [12.5 mm]
	d	ø0.47 in [12 mm]	ø0.75 in [19 mm]	ø0.75 in [19 mm]	ø0.75 in [19 mm]	ø0.75 in [19 mm]
	e	ø0.26 in (6.5 mm)	ø0.26 in (6.5 mm)	ø0.26 in (6.5 mm)	ø9	ø9
	f	0.35 in [9 mm]	0.35 in [9 mm]	0.35 in [9 mm]	ø9.8	ø9.8
Max. weight		13.5 / 14.2	50.7 lbs [23 kg]	59.5 lbs [27 kg]	99.2 lbs [45 kg]	143.3 lbs [65 kg]

4.4: A5, B1 and B2 mechanical dimensions

1) The dimensions state the maximum height, width and depth needed for mounting the adjustable frequency drive when the top cover is mounted.

5. Electrical installation

5.1. How to connect

5.1.1. Cables General



NOTE

Always comply with national and local regulations on cable cross-sections.

Details of terminal tightening torques.

Enclosure	Power (kW)		Torque (Nm)					
	200-240 V	380-480 V	Line	Motor	DC connection	Brake	Ground	Relay
A2	0.25 - 3.0	0.37 - 4.0	1.8	1.8	1.8	1.8	3	0.6
A3	3.7	5.5 - 7.5	1.8	1.8	1.8	1.8	3	0.6
A5	0.25 - 3.7	0.37 - 7.5	1.8	1.8	1.8	1.8	3	0.6
B1	5.5 - 7.5	11 - 18.5	1.8	1.8	1.5	1.5	3	0.6
B2	11	22	2.5	2.5	3.7	3.7	3	0.6
	15	30	4.5	4.5	3.7	3.7	3	0.6
C1	18.5 - 22	37 - 55	10	10	10	10	3	0.6
C2	30	75	14	14	14	14	3	0.6
	45	90	24	24	14	14	3	0.6

5.1: Tightening of terminals.

5.1.2. Fuses

Branch circuit protection:

In order to protect the installation against electrical and fire hazards, all branch circuits in an installation - the switch gear, machines, etc. - must be protected from both short circuit and overcurrent in accordance with national/international regulations.

Short circuit protection:

The adjustable frequency drive must be protected against short circuit in order to avoid electrical or fire hazard. Danfoss recommends using the fuses mentioned in tables 4.3 and 4.4 in order to protect service personnel and equipment in case of an internal failure in the unit. The adjustable frequency drive provides full short circuit protection in case of a short circuit in the motor output.

Overcurrent protection:

Provide overload protection to avoid fire hazard due to overheating of the cables in the installation. Overcurrent protection must always be provided according to national regulations. The adjustable frequency drive is equipped with internal overcurrent protection that can be used for upstream overload protection (UL applications excluded). See par. 4-18. Fuses must be designed for protection in a circuit capable of supplying a maximum of 100,000 A_{rms} (symmetrical), 500 V / 600 V maximum.

Non-UL compliance

If UL/cUL is not to be complied with, Danfoss recommends using the fuses mentioned in table 4.2, which will ensure compliance with EN50178:

In case of malfunction, not following the recommendation may result in unnecessary damage to the adjustable frequency drive.

VLT AQUA	Max. fuse size	Voltage	Type
200-240 V			
K25-1K1	16A ¹	200-240 V	type gG
1K5	16A ¹	200-240 V	type gG
2K2	25A ¹	200-240 V	type gG
3K0	25A ¹	200-240 V	type gG
3K7	35A ¹	200-240 V	type gG
5K5	50A ¹	200-240 V	type gG
7K5	63A ¹	200-240 V	type gG
11K	63A ¹	200-240 V	type gG
15K	80A ¹	200-240 V	type gG
18K5	125A ¹	200-240 V	type gG
22K	125A ¹	200-240 V	type gG
30K	160A ¹	200-240 V	type gG
37K	200A ¹	200-240 V	type aR
45K	250A ¹	200-240 V	type aR
380-480 V			
K37-1K5	10A ¹	380-480 V	type gG
2K2-4K0	20A ¹	380-480 V	type gG
5K5-7K5	32A ¹	380-480 V	type gG
11K	63A ¹	380-480 V	type gG
15K	63A ¹	380-480 V	type gG
18K	63A ¹	380-480 V	type gG
22K	63A ¹	380-480 V	type gG
30K	80A ¹	380-480 V	type gG
37K	100A ¹	380-480 V	type gG
45K	125A ¹	380-480 V	type gG
55K	160A ¹	380-480 V	type gG
75K	250A ¹	380-480 V	type aR
90K	250A ¹	380-480 V	type aR

5.2: Non-UL fuses 200 V to 480 V

1) Max. fuses - refer to national/international regulations to select an appropriate fuse size.

UL Compliance

VLT AQUA	Bussmann	Bussmann	Bussmann	SIBA	Littel fuse	Ferraz-Shawmut	Ferraz-Shawmut
200-240 V							
Type	Type RK1	Type J	Type T	Type RK1	Type RK1	Type CC	Type RK1
K25-1K1	KTN-R10	JKS-10	JJN-10	5017906-010	KLN-R10	ATM-R10	A2K-10R
1K5	KTN-R15	JKS-15	JJN-15	5017906-015	KLN-R15	ATM-R15	A2K-15R
2K2	KTN-R20	JKS-20	JJN-20	5012406-020	KLN-R20	ATM-R20	A2K-20R
3K0	KTN-R25	JKS-25	JJN-25	5012406-025	KLN-R25	ATM-R25	A2K-25R
3K7	KTN-R30	JKS-30	JJN-30	5012406-030	KLN-R30	ATM-R30	A2K-30R
5K5	KTN-R50	JKS-50	JJN-50	5012406-050	KLN-R50	-	A2K-50R
7K5	KTN-R50	JKS-60	JJN-60	5012406-050	KLN-R60	-	A2K-50R
11K	KTN-R60	JKS-60	JJN-60	5014006-063	KLN-R60	-	A2K-60R
15K	KTN-R80	JKS-80	JJN-80	5014006-080	KLN-R80	-	A2K-80R
18K5	KTN-R125	JKS-150	JJN-125	2028220-125	KLN-R125	-	A2K-125R
22K	KTN-R125	JKS-150	JJN-125	2028220-125	KLN-R125	-	A2K-125R
30K	FWX-150	-	-	2028220-150	L25S-150	-	A25X-150
37K	FWX-200	-	-	2028220-200	L25S-200	-	A25X-200
45K	FWX-250	-	-	2028220-250	L25S-250	-	A25X-250

5.3: UL fuses 200-240 V

VLT AQUA	Bussmann	Bussmann	Bussmann	SIBA	Littel fuse	Ferraz-Shawmut	Ferraz-Shawmut
380-480 V							
kW	Type RK1	Type J	Type T	Type RK1	Type RK1	Type CC	Type RK1
11K	KTS-R40	JKS-40	JJS-40	5014006-040	KLS-R40	-	A6K-40R
15K	KTS-R40	JKS-40	JJS-40	5014006-040	KLS-R40	-	A6K-40R
18K	KTS-R50	JKS-50	JJS-50	5014006-050	KLS-R50	-	A6K-50R
22K	KTS-R60	JKS-60	JJS-60	5014006-063	KLS-R60	-	A6K-60R
30K	KTS-R80	JKS-80	JJS-80	2028220-100	KLS-R80	-	A6K-80R
37K	KTS-R100	JKS-100	JJS-100	2028220-125	KLS-R100	-	A6K-100R
45K	KTS-R125	JKS-150	JJS-150	2028220-125	KLS-R125	-	A6K-125R
55K	KTS-R150	JKS-150	JJS-150	2028220-160	KLS-R150	-	A6K-150R
75K	FWH-220	-	-	2028220-200	L50S-225	-	A50-P225
90K	FWH-250	-	-	2028220-250	L50S-250	-	A50-P250

5.4: UL fuses 380-480 V

KTS fuses from Bussmann may substitute for KTN in 240 V adjustable frequency drives.

FWH fuses from Bussmann may substitute for FWX in 240 V adjustable frequency drives.

KLSR fuses from LITTEL FUSE may substitute for KLSR fuses in 240 V adjustable frequency drives.

L50S fuses from LITTEL FUSE may substitute for L50S fuses in 240 V adjustable frequency drives.

A6KR fuses from FERRAZ SHAWMUT may substitute for A2KR in 240 V adjustable frequency drives.

A50X fuses from FERRAZ SHAWMUT may substitute for A25X in 240 V adjustable frequency drives.

5.1.3. Grounding and IT line power

The ground connection cable cross-section must be at least 0.016 in.² [10 mm²] or 2 rated line power wires terminated separately according to *EN 50178* or *IEC 61800-5-1*, unless national regulations specify otherwise. Always comply with national and local regulations on cable cross-sections.

The power supply is connected to the main disconnect switch if this is included.

NOTE
Make sure that the line voltage corresponds to the line voltage of the adjustable frequency drive nameplate.

IT Line
Do not connect 400 V adjustable frequency drives with RFI filters to line supplies with a voltage between phase and ground of more than 440 V. For IT lines and delta ground (grounded leg), line voltage may exceed 440 V between phase and ground.

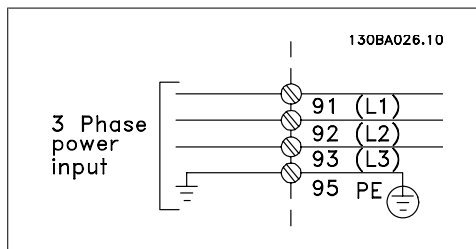

5.1: Terminals for line supply and grounding.

5

5.1.4. Line power wiring overview

Please refer to the following table for the line power wiring connection instructions.

Enclosure:	A2 (IP 20/ IP 21)	A3 (IP 20/ IP 21)	A5 (IP 55/ IP 66)	B1 (IP 21/ IP 55/IP 66)	B2 (IP 21/ IP 55/IP 66)	C1 (IP 21/ IP 55/66)	C2 (IP 21/ IP 55/66)
Motor size:							
200-240 V	0.25-3.0 kW	3.7 kW	0.25-3.7 kW	5.5-7.5 kW	11-15 kW	18.5-22 kW	30-45 kW
380-480 V	0.37-4.0 kW	5.5-7.5 kW	0.37-7.5 kW	11-18.5 kW	22-30 kW	37-55 kW	75-90 kW
Goto:	5.1.5		5.1.6	5.1.7		5.1.8	

5.5: Line power wiring table.

5.1.5. Line connection for A2 and A3

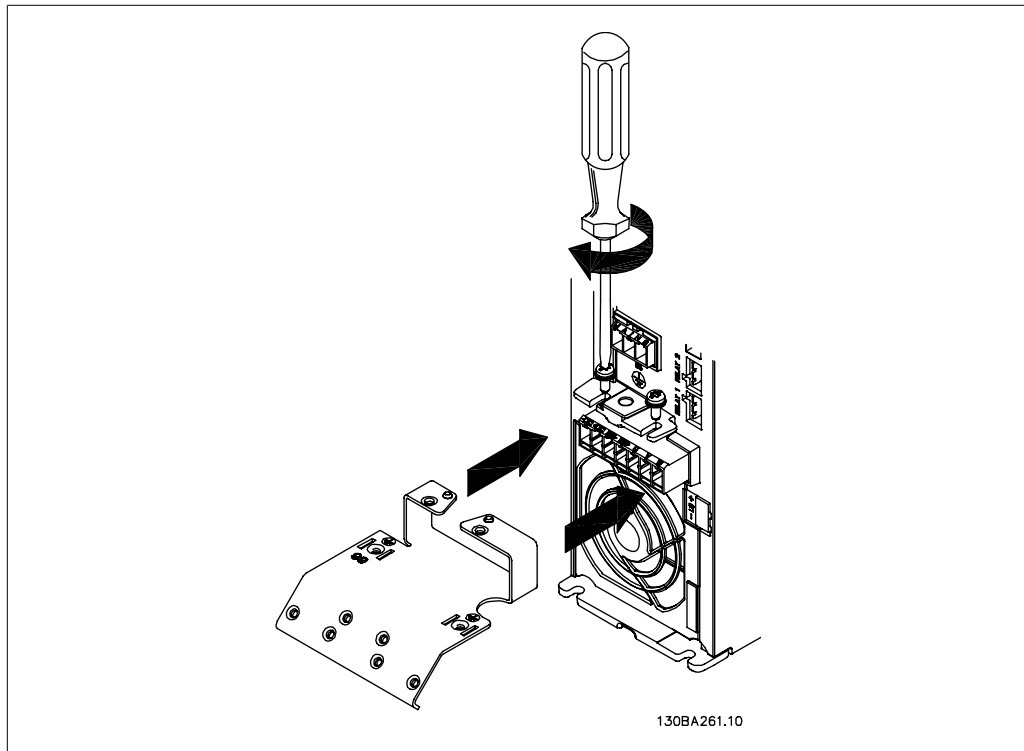

5.2: First mount the two screws on the mounting plate, slide it into place and tighten fully.

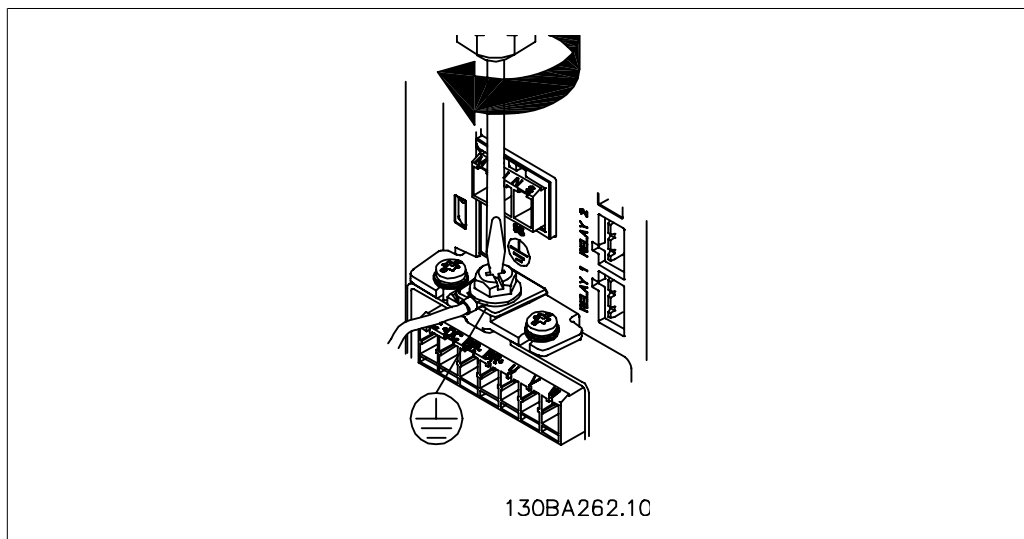

5.3: When mounting cables, first mount and tighten the ground cable.



The ground connection cable cross-section must be at least 0.016 in² [10 mm²] or 2 rated line power wires terminated separately according to *EN 50178/IEC 61800-5-1*.

5

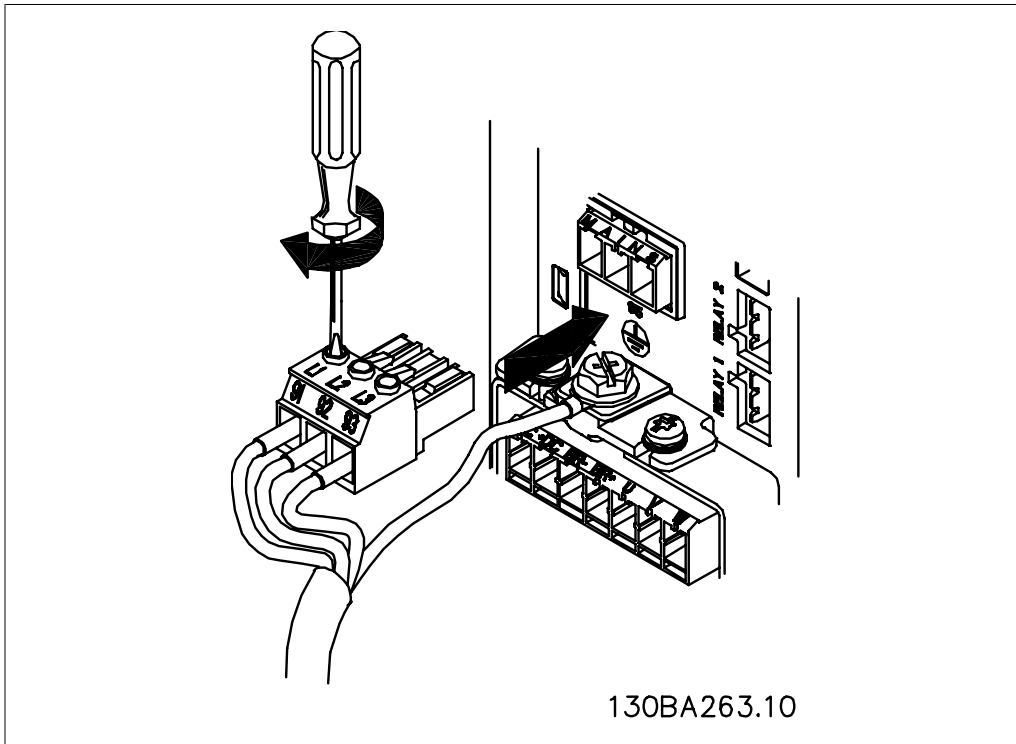

5.4: Then insert the line power plug and tighten the wires.

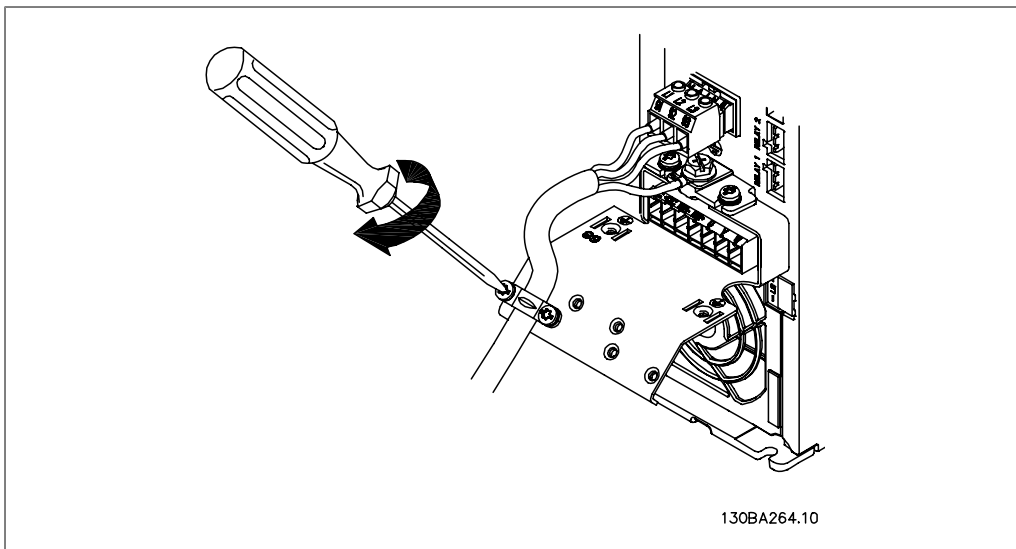

5.5: Finally, tighten the support bracket on the line power wires.

5.1.6. Line power connection for A5

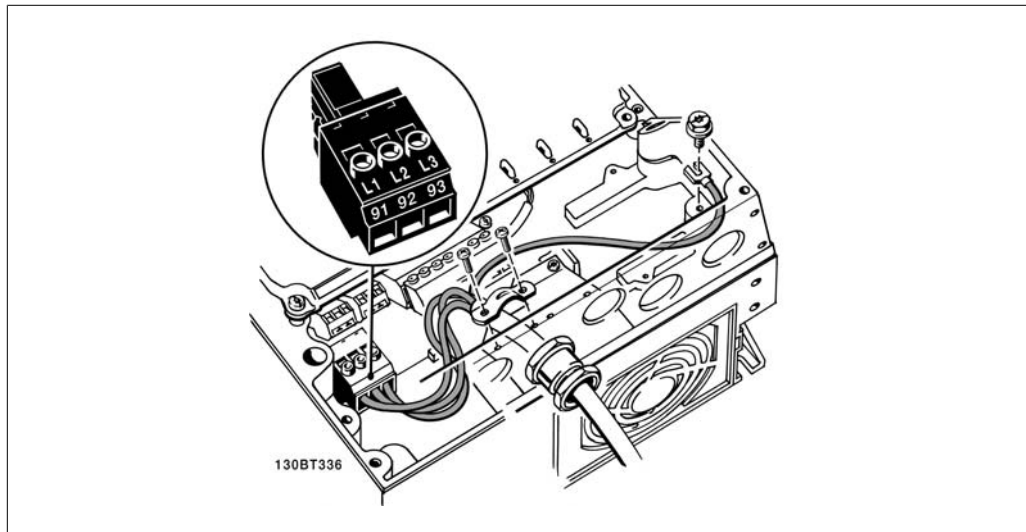

5.6: How to connect to line power and grounding without the line disconnect switch. Note that a cable clamp is used.

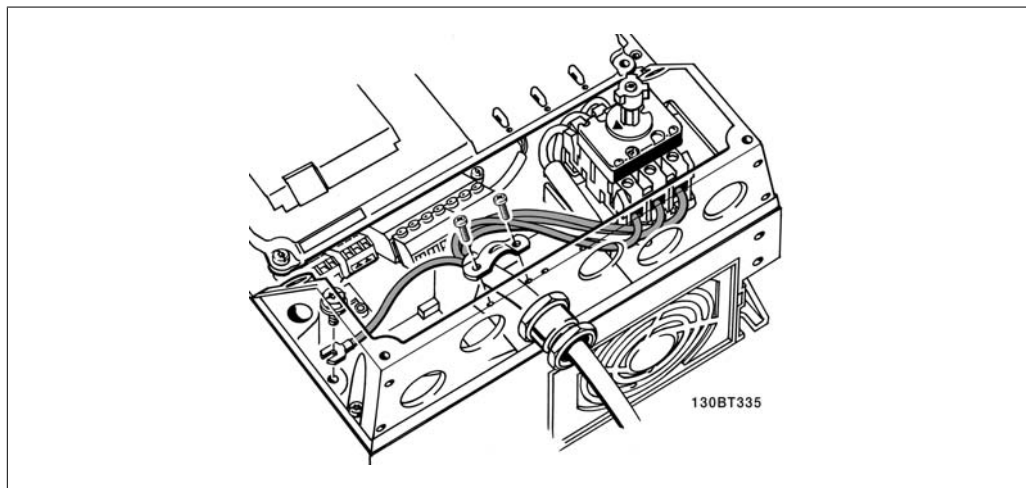

5.7: How to connect to line power and grounding with the line disconnect switch.

5.1.7. Line power connection for B1 and B2.

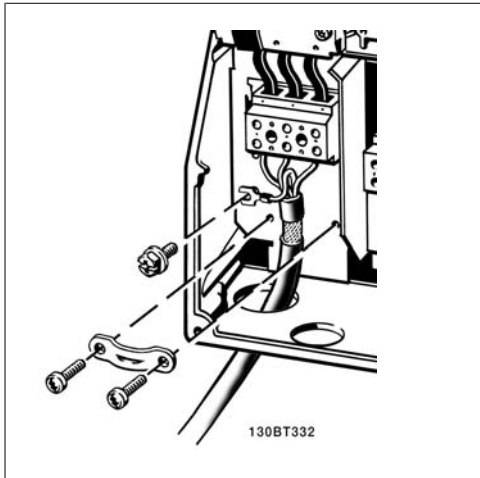

5.8: How to connect to the line supply and grounding.

5.1.8. Line power connection for C1 and C2.

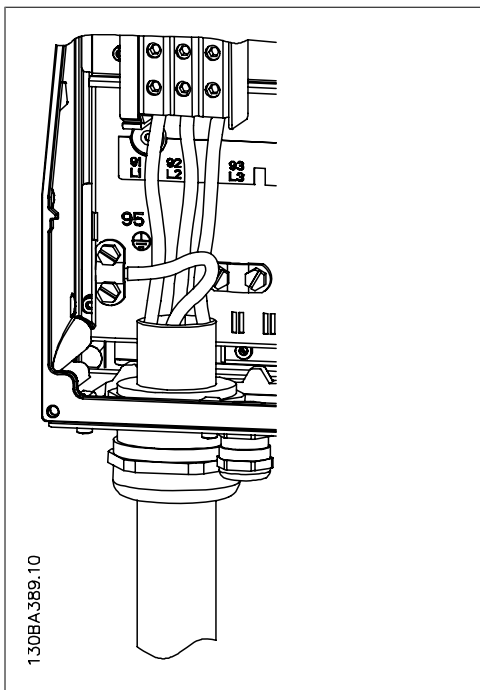

5.9: How to connect to the line supply and grounding.

5.1.9. How to connect the motor - foreword

See section *General Specifications* for correct dimensioning of motor cable cross-section and length.

- Use a shielded/armored motor cable to comply with EMC emission specifications (or install the cable in a metal conduit).
- Keep the motor cable as short as possible to reduce the noise level and leakage currents.
- Connect the motor cable shield/armor to both the decoupling plate of the adjustable frequency drive and to the metal of the motor. (Same applies to both ends of the metal conduit if used instead of a shield.)
- Make the shield connections with the largest possible surface area (by using a cable clamp or an EMC cable gland). This is done by using the supplied installation devices in the adjustable frequency drive.
- Avoid terminating the shield by twisting the ends (pigtailed), as this will spoil high frequency shielding effects.
- If it is necessary to break the continuity of the shield to install a motor isolator or motor relay, the continuity must be maintained with the lowest possible HF impedance.

Cable length and cross-section

The adjustable frequency drive has been tested with a given length of cable and a given cross-section of that cable. If the cross-section is increased, the cable capacitance - and thus the leakage current - may increase, thereby requiring that the cable length is reduced accordingly.

Switching frequency

When adjustable frequency drives are used together with sine wave filters to reduce the acoustic noise from a motor, the switching frequency must be set according to the sine wave filter instructions in *Par. 14-01*.

Precautions while using Aluminum conductors

Aluminum conductors are not recommended for cable cross-sections less than 0.054 in² [35 mm²]. Terminals can accept aluminum conductors, but the conductor surface has to be clean, oxidation must be removed, and the area must be sealed by neutral acid-free Vaseline grease before the conductor is connected.

Furthermore, the terminal screw must be retightened after two days due to the softness of the aluminum. It is crucial to ensure the connection makes a gas tight joint, otherwise the aluminum surface will oxidize again.

All types of three-phase asynchronous standard motors can be connected to the adjustable frequency drive. Normally, small motors are star-connected (230/400 V, D/Y). Large motors are delta-connected (400/690 V, D/Y). Refer to the motor name plate for the correct connection mode and voltage.

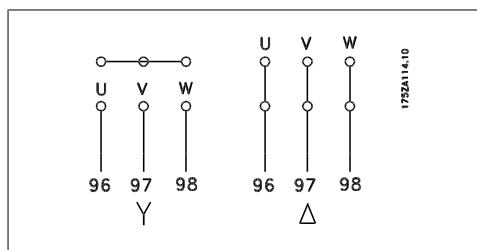

5.10: Terminals for motor connection





NOTE
In motors without phase insulation paper or other insulation reinforcement suitable for operation with a voltage supply (such as an adjustable frequency drive), fit a sine-wave filter on the output of the adjustable frequency drive. (Motors that comply with IEC 60034-17 do not require a sine-wave filter).

No.	96	97	98	Motor voltage 0-100% of line voltage.
	U	V	W	3 cables out of motor
	U1	V1	W1	6 cables out of motor, Delta-connected
	W2	U2	V2	
	U1	V1	W1	6 cables out of motor, Star-connected
				U2, V2, W2 to be interconnected separately (optional terminal block)
No.	99			Ground connection
	PE			

5.6: 3 and 6 cable motor connection.

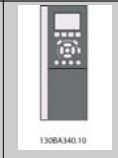
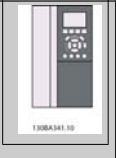
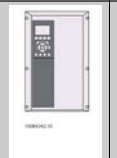
5.1.10. Motor wiring overview

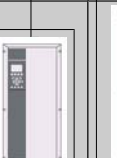
5

Enclosure:	A2 (IP 20/ IP 21)	A3 (IP 20/ IP 21)	A5 (IP 55/ IP 66)	B1 (IP 21/ IP 55/IP 66)	B2 (IP 21/ IP 55/IP 66)	C1 (IP 21/ IP 55/IP 66)	C2 (IP 21/ IP 55/IP 66)
							
Motor size:							
200-240 V	0.25-3.0 kW	3.7 kW	0.25-3.7 kW	5.5-7.5 kW	11-15 kW	18.5-22 kW	30-45 kW
380-480 V	0.37-4.0 kW	5.5-7.5 kW	0.37-7.5 kW	11-18.5 kW	22-30 kW	37-55 kW	75-90 kW
Goto:	5.1.11		5.1.12	5.1.13		5.1.14	

5.7: Motor wiring table.

5.1.11. Motor connection for A2 and A3

Follow these drawings step-by-step for connecting the motor to the adjustable frequency drive.

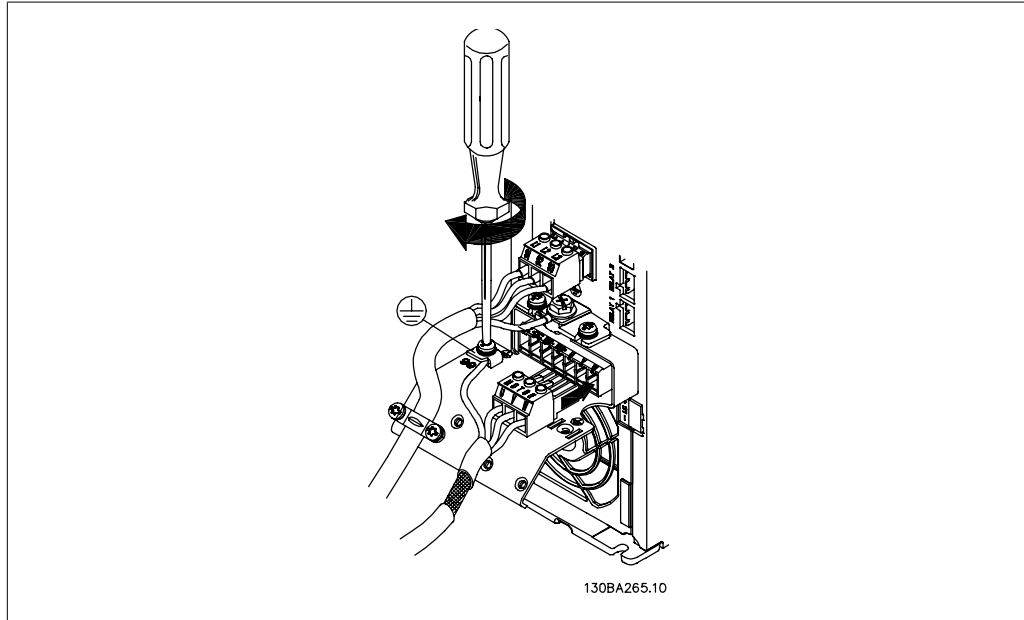

5.11: First terminate the motor ground, then place motor U, V and W wires in the plug and tighten them.

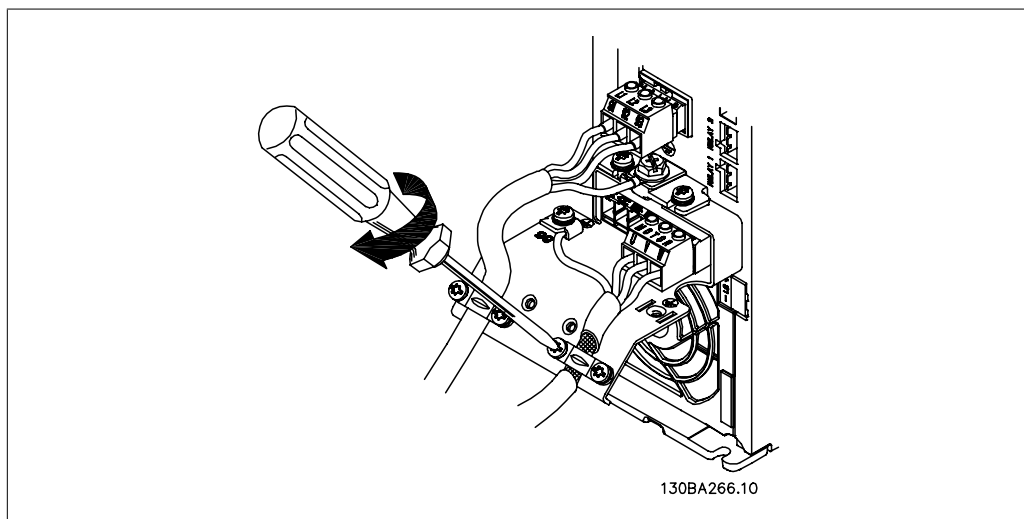

5.12: Mount cable clamp to ensure 360 degree connection between chassis and shield; ensure that the outer insulation of the motor cable is removed under the clamp.

5.1.12. Motor connection for A5

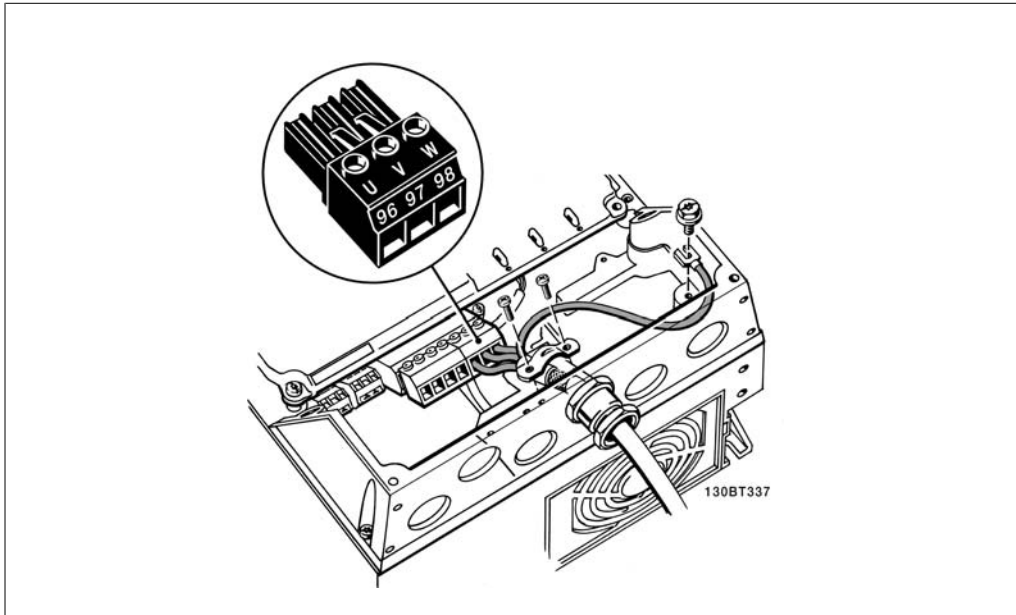

5.13: First, terminate the motor ground, then insert the motor u, v and w wires in the terminal and tighten them. Please ensure that the outer insulation of the motor cable is removed under the EMC clamp.

5.1.13. Motor connection for B1 and B2

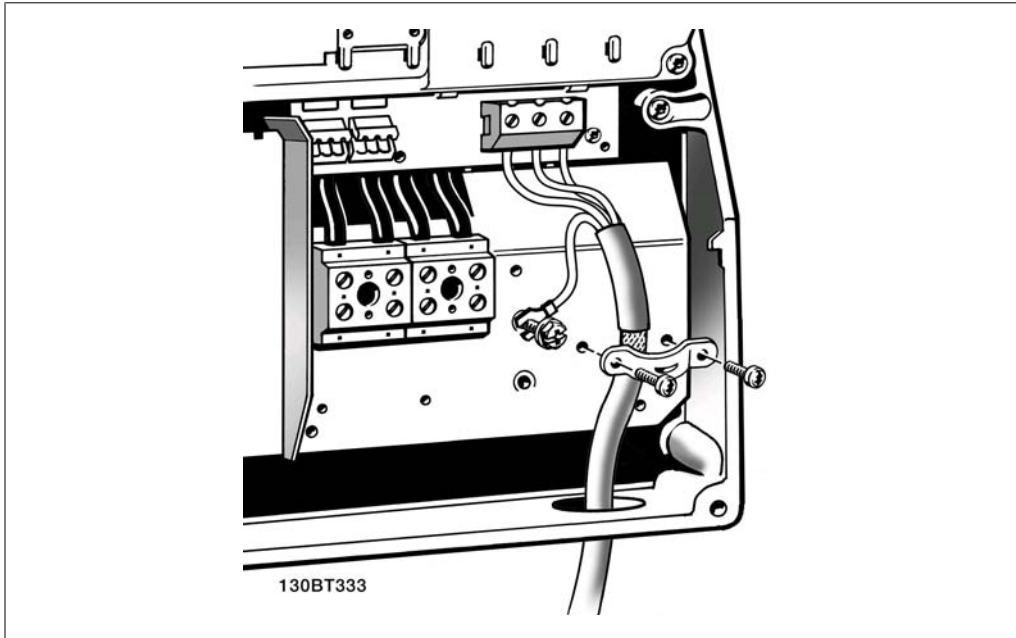

5.14: First terminate the motor ground, then place motor U, V and W wires in the terminal and tighten them. Please ensure that the outer insulation of the motor cable is removed under the EMC clamp.

5.1.14. Motor connection for C1 and C2

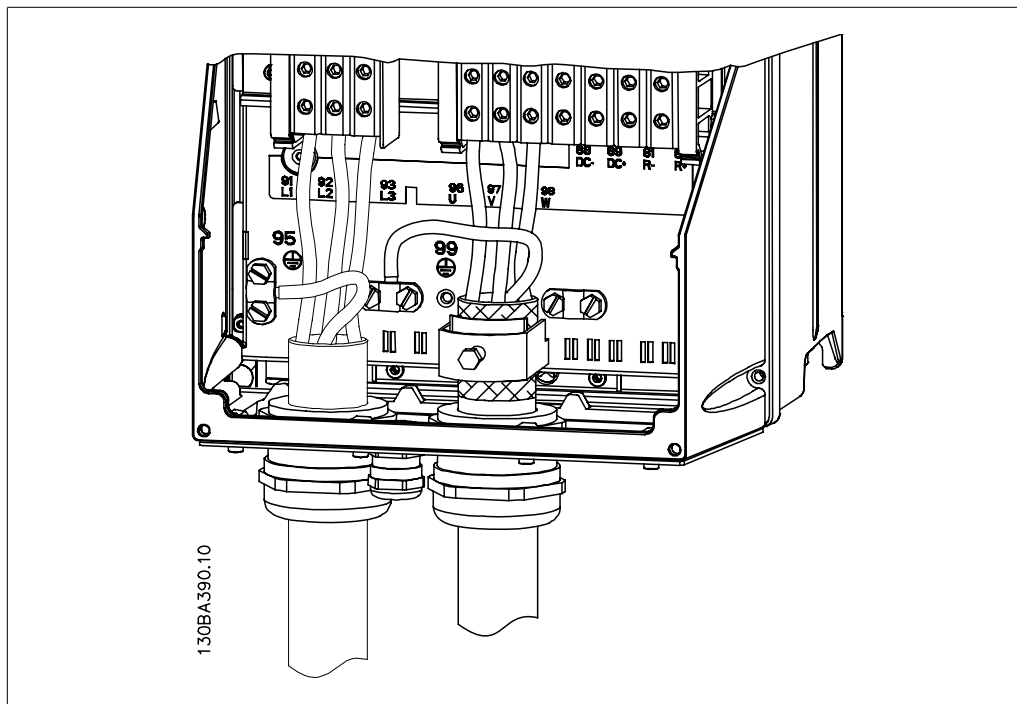

5.15: First terminate the motor ground, then place motor U, V and W wires in the terminal and tighten them. Please ensure that the outer insulation of the motor cable is removed under the EMC clamp.

5.1.15. Wiring Example and Testing

The following section describes how to terminate and access control wires. For an explanation of programming and wiring control terminals, please see the chapter entitled *How to program the adjustable frequency drive*.

5.1.16. Access to Control Terminals

All terminals to the control cables are located underneath the terminal cover on the front of the adjustable frequency drive. Remove the terminal cover with a screwdriver.

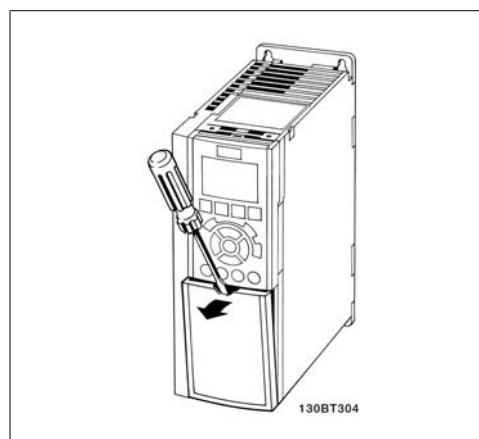

5.16: A2 and A3 enclosures

Remove front cover to access control terminals. When replacing the front cover, ensure proper fastening by applying a torque of 2 Nm.

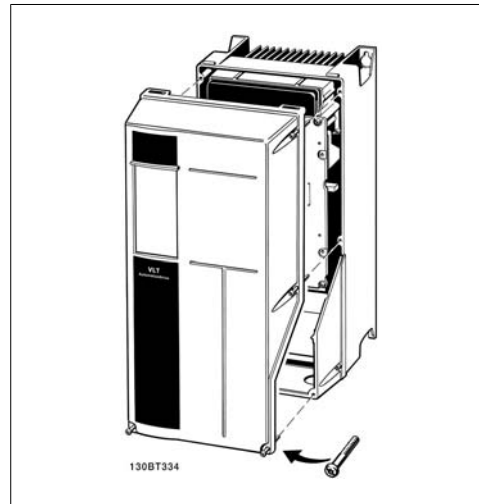

5.17: A5, B1, B2, C1 and C2 enclosures

5.1.17. Control Terminals

Drawing reference numbers:

1. 10-pole plug, digital I/O.
2. 3-pole plug, RS-485 bus.
3. 6-pole, analog I/O.
4. USB connection.

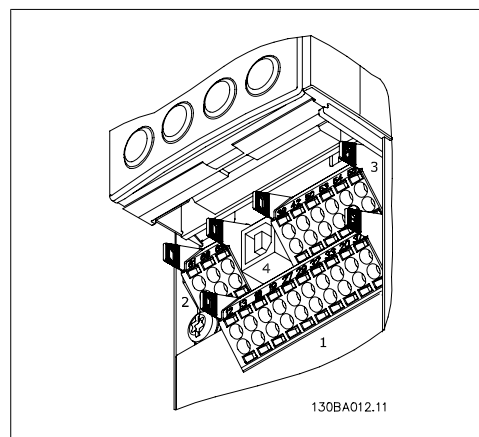

5.18: Control terminals (all enclosures)

5.1.18. How to Test Motor and Direction of Rotation.



Note that unintended motor start can occur; make sure no personnel or equipment is in danger!

Please follow these steps to test the motor connection and direction of rotation. Start with no power to the unit.

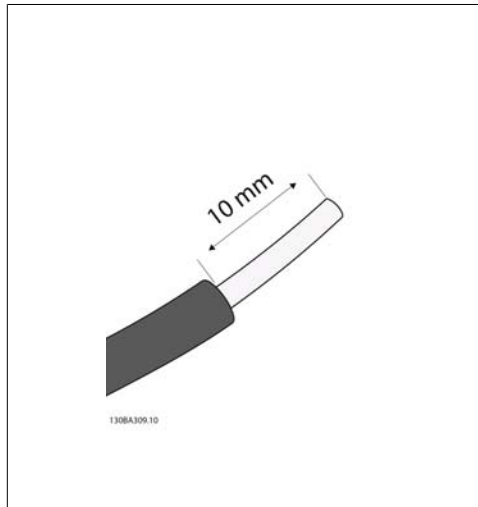

5.19:
Step 1: First, remove the insulation on both ends of a 1.97-2.76 in. [50 to 70 mm] piece of wire.

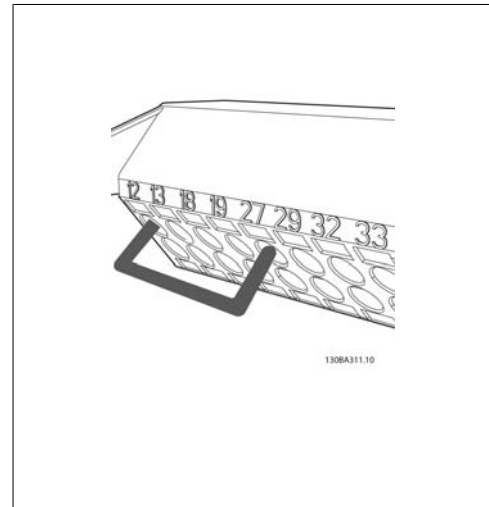

5.21:
Step 3: Insert the other end in terminal 12 or 13. (Note: For units with the Safe Stop function, the existing jumper between terminal 12 and 37 should not be removed for the unit to be able to run!)

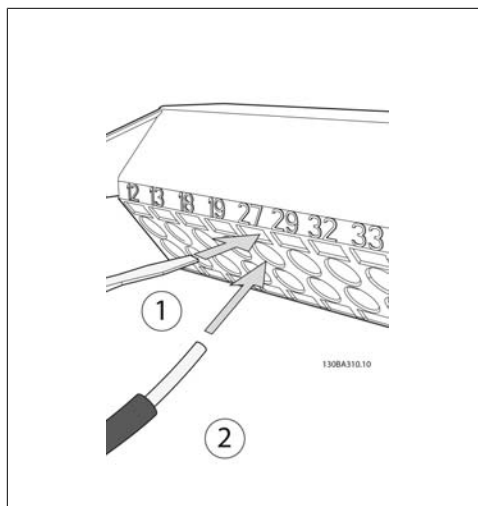

5.20:
Step 2: Insert one end in terminal 27 using a suitable terminal screwdriver. (Note: For units with the Safe Stop function, the existing jumper between terminal 12 and 37 should not be removed for the unit to be able to run!)

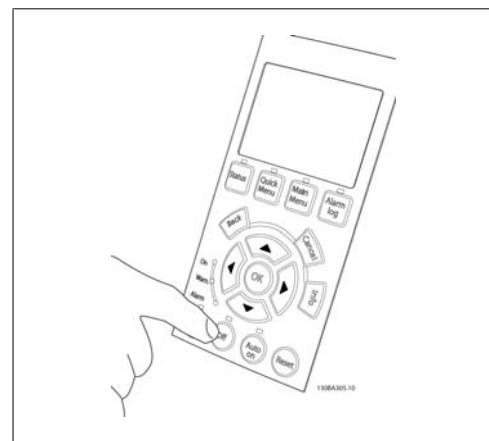

5.22:
Step 4: Power up the unit and press the [Off] button. In this state, the motor should not rotate. Press [Off] to stop the motor at any time. Note that the LED on the [OFF] button should be lit. If alarms or warnings are flashing, please see chapter 7 for more information.

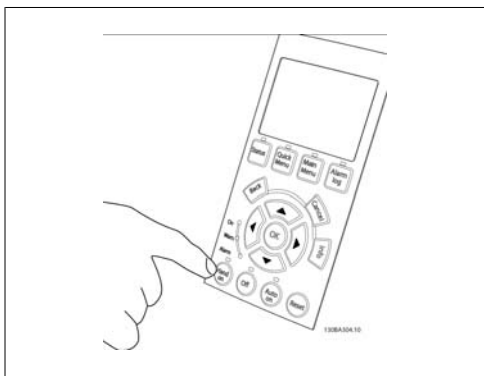

5.23:

Step 5: By pressing the [Hand on] button, the LED above the button should be lit and the motor may rotate.



5.24:

Step 6: The speed of the motor can be seen in the LCP. It can be adjusted by pushing the up ▲ and down ▼ arrow buttons.



5.25:

Step 7: To move the cursor, use the left ◀ and right ▶ arrow buttons. This enables speed changes by larger increments.



5.26:

Step 8: Press the [Off] button to stop the motor again.

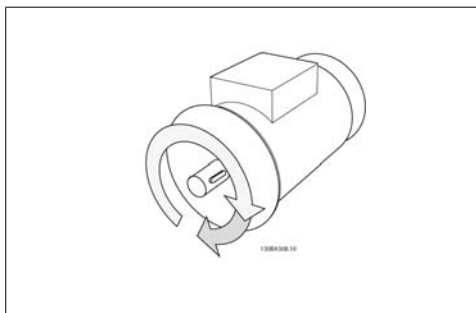

5.27:

Step 9: Change two motor wires if the desired rotation of direction is not achieved.

Remove line power from the adjustable frequency drive before changing motor wires.

5.1.19. Electrical Installation and Control Cables

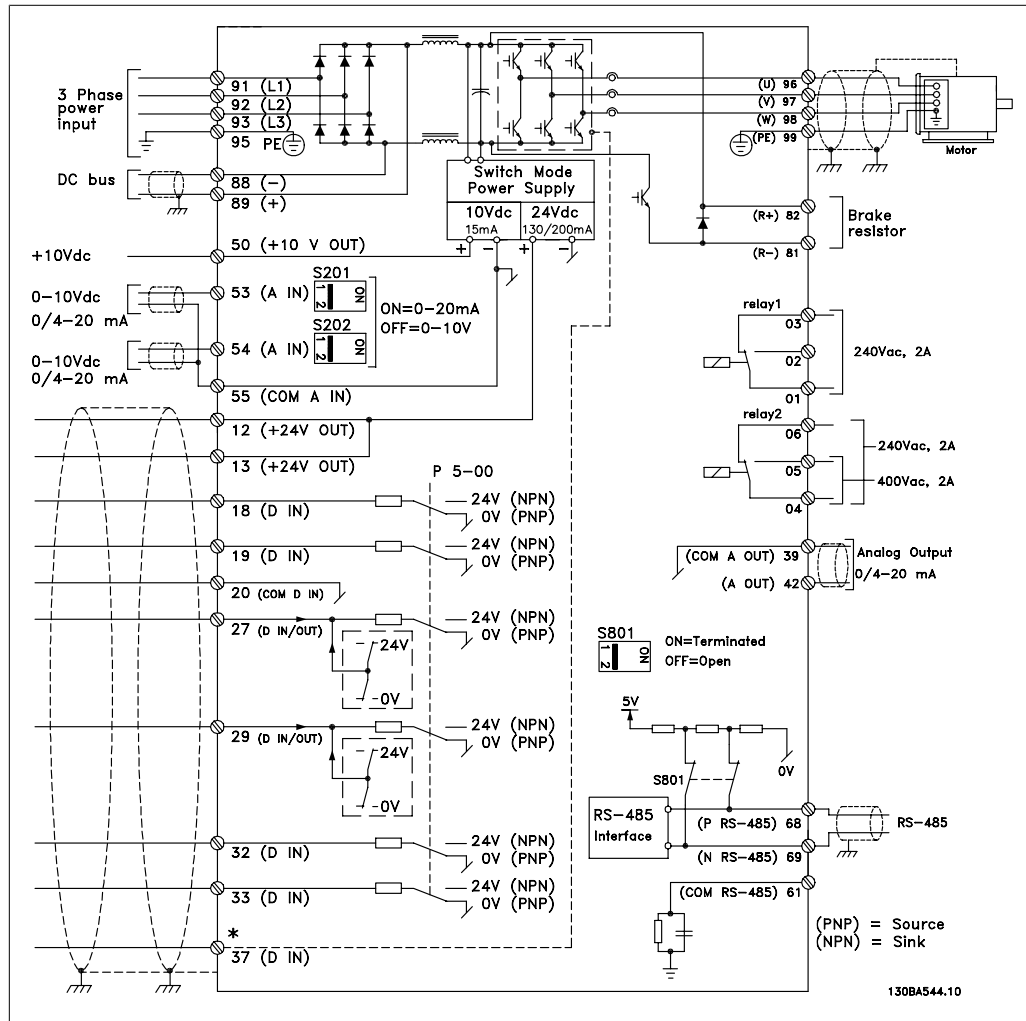

5.28: Diagram showing all electrical terminals. (Terminal 37 present for units with safe stop function only.)

Very long control cables and analog signals may, in rare cases and depending on the installation, result in 50/60 Hz ground loops due to noise from line supply cables.

If this occurs, break the shield or insert a 100 nF capacitor between shield and chassis.

NOTE
The common of digital / analog inputs and outputs should be connected to separate common terminals 20, 39, and 55. This will prevent ground current interference among groups. For example, it prevents switching on digital inputs from disturbing analog inputs.

**NOTE**

Control cables must be shielded/armored.

1. Use a clamp from the accessory bag to connect the shield to the adjustable frequency drive decoupling plate for control cables.

See section entitled *Grounding of Shielded/Armored Control Cables* for the correct termination of control cables.

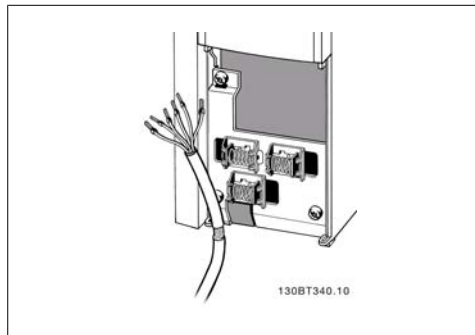

5.29: Control cable clamp.

5.1.20. Switches S201, S202, and S801

Switches S201 (AI 53) and S202 (AI 54) are used to select a current (0-20 mA) or a voltage (0 to 10 V) configuration of the analog input terminals 53 and 54 respectively.

Switch S801 (BUS TER.) can be used to enable termination on the RS-485 port (terminals 68 and 69).

Please note that the switches may be covered by an option, if so equipped.

Default setting:

S201 (AI 53) = OFF (voltage input)

S202 (AI 54) = OFF (voltage input)

S801 (Bus termination) = OFF

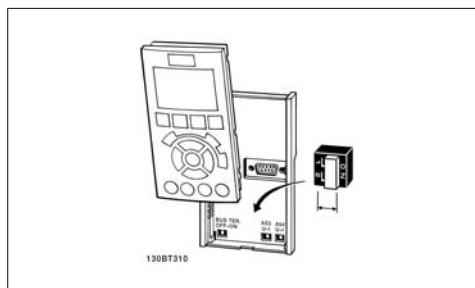

5.30: Switches location.

5.2. Final optimization and test

5.2.1. Final optimization and test

To optimize motor shaft performance and optimize the adjustable frequency drive for the connected motor and installation, please follow these steps: Ensure that adjustable frequency drive and motor are connected, and power is applied to the adjustable frequency drive.

**NOTE**

Before power-up, ensure that connected equipment is ready for use.

Step 1. Locate motor nameplate.

 **NOTE**
The motor is either star- (Y) or delta-connected (Δ). This information is located on the motor nameplate data.

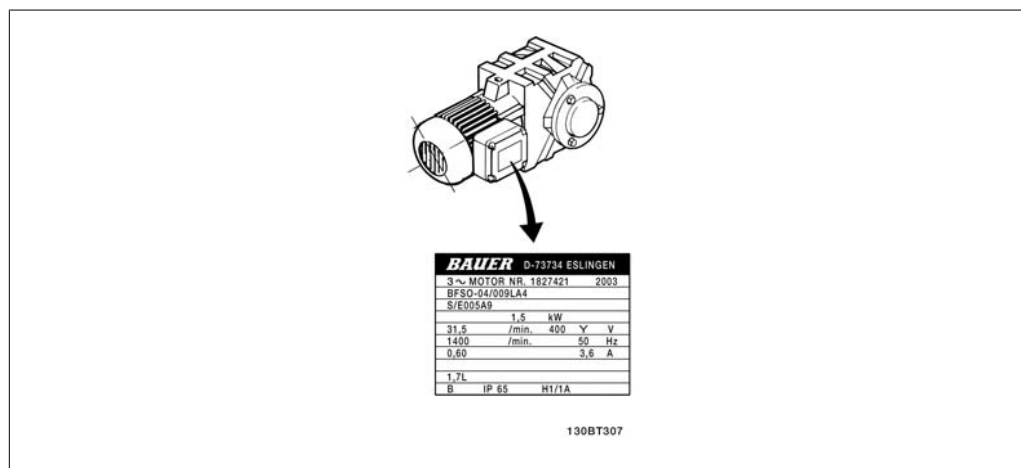

5.31: Motor nameplate example

Step 2. Enter motor nameplate data in the following parameter list.

To access the list, first press [QUICK MENU] key, then select "Q2 Quick Set-up."

1.	Motor Power [kW] or Motor Power [HP]	par. 1-20 par. 1-21
2.	Motor Voltage	par. 1-22
3.	Motor Frequency	par. 1-23
4.	Motor Current	par. 1-24
5.	Motor Nominal Speed	par. 1-25

5.8: Motor related parameters

Step 3. Activate Automatic Motor Adaptation (AMA)

Performing AMA ensures the best possible performance. AMA automatically takes measurements from the specific motor connected and compensates for installation variances.

1. Connect terminal 27 to terminal 12 or use [MAIN MENU] and set Terminal 27 par. 5-12 to *No operation* (par. 5-12 [0])
2. Press [QUICK MENU], select "Q2 Quick Set-up", scroll down to AMA par. 1-29.
3. Press [OK] to activate the AMA par. 1-29.
4. Choose between complete or reduced AMA. If the sine wave filter is mounted, run only reduced AMA, or remove the sine wave filter during the AMA procedure.
5. Press the [OK] key. The display should show "Press [Hand on] to start."
6. Press the [Hand on] key. A progress bar indicates if the AMA is in progress.

Stop the AMA during operation.

1. Press the [OFF] key. The adjustable frequency drive enters into alarm mode and the display shows that the AMA was terminated by the user.

Successful AMA

1. The display shows "Press [OK] to finish AMA."
2. Press the [OK] key to exit the AMA state.

Unsuccessful AMA

1. The adjustable frequency drive enters into alarm mode. A description of the alarm can be found in the *Troubleshooting* section.
2. "Report Value" in the [Alarm Log] shows the last measuring sequence carried out by the AMA before the adjustable frequency drive entered alarm mode. This number, along with the description of the alarm, will assist in troubleshooting. If contacting Danfoss Service, make sure to mention the number and alarm description.

	<p>NOTE An unsuccessful AMA is often caused by incorrectly entered motor name plate data or too big of a difference between the motor and the adjustable frequency drive power sizes.</p>
--	--

Step 4. Set speed limit and ramp time

Set up the desired limits for speed and ramp time.

Minimum Reference	par. 3-02
Maximum Reference	par. 3-03

Motor Speed Low Limit	par. 4-11 or 4-12
Motor Speed High Limit	par. 4-13 or 4-14

Ramp 1 Ramp-up Time [s]	par. 3-41
Ramp 1 Ramp-down Time 1 [s]	par. 3-42

6. How to operate the adjustable frequency drive

6.1. Ways of Operation

6.1.1. Ways of Operation

The adjustable frequency drive can be operated in 3 ways:

1. Graphical Local Control Panel (GLCP), see 6.1.2
2. Numeric Local Control Panel (NLCP), see 6.1.3
3. RS-485 serial communication or USB, both for PC connection, see 6.1.4

If the adjustable frequency drive is equipped with the serial communication option, please refer to the relevant documentation.

6.1.2. How to operate the Graphical LCP (GLCP)

The following instructions apply to the GLCP (LCP 102).

The GLCP is divided into four functional groups:

1. Graphical display with Status lines.
2. Menu keys and LEDs - for selecting mode, changing parameters and switching between display functions.
3. Navigation keys and lights (LEDs).
4. Operation keys and LEDs.

Graphical display:

The LCD display is backlit with a total of 6 alpha-numeric lines. All data is displayed on the LCP. This can show up to five operating variables while in [Status] mode.

Display lines:

- a. **Status line:** Status messages displaying icons and graphics.1
- b. **Line 1-2:** Operator data lines displaying data and variables defined or chosen by the user. By pressing the [Status] key, up to one extra line can be added.1
- c. **Status line:** Status messages displaying text.1

The display is divided into 3 sections:

Top section(a) shows the status when in status mode or up to 2 variables when not in status mode and in the case of an alarm/warning.

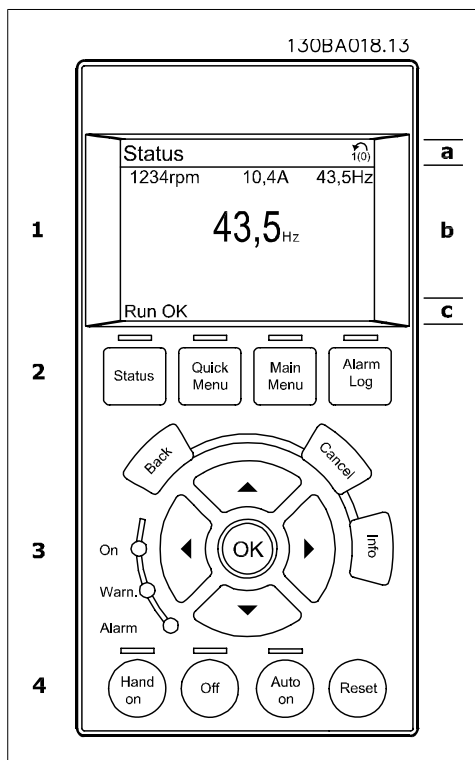

The number of the active set-up (selected as the active set-up in par. 0-10) is shown. When programming in another set-up than the active set-up, the number of the set-up being programmed appears to the right in brackets.

The **Middle section(b)** shows up to 5 variables with related unit, regardless of status. In case of an alarm/warning, the warning is shown instead of the variables.

It is possible to toggle between three status readout displays by pressing the [Status] key. Operating variables with different formatting are shown in each status screen - see below.

Several values or measurements can be linked to each of the displayed operating variables. The values/measurements to be displayed can be defined via par. 0-20, 0-21, 0-22, 0-23, and 0-24, which can be accessed via [QUICK MENU], "Q3 Function Set-ups", "Q3-1 General Settings", "Q3-11 Display Settings".

Each value/measurement readout parameter selected in par. 0-20 to par. 0-24 has its own scale and number of digits after a possible decimal point. Larger numeric values are displayed with few digits after the decimal point.

Ex.: Current readout
5.25 A; 15.2 A 105 A.

Status display I:

This readout state is standard after start-up or initialization

Use [INFO] to obtain information about the value/measurement linked to the displayed operating variables (1.1, 1.2, 1.3, 2 and 3). See the operating variables shown in the display in this illustration. 1.1, 1.2 and 1.3 are shown in small size. 2 and 3 are shown in medium size.

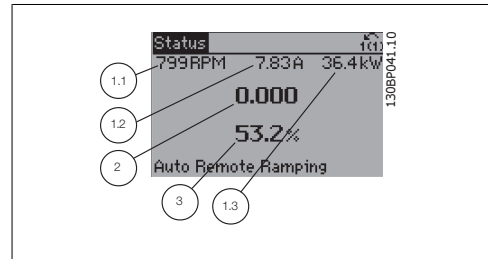

Status display II:

See the operating variables (1.1, 1.2, 1.3 and 2) shown in the display in this illustration.

In the example, Speed, Motor current, Motor power and Frequency are selected as variables in the first and second lines.

1.1, 1.2 and 1.3 are shown in small size. 2 is shown in large size.

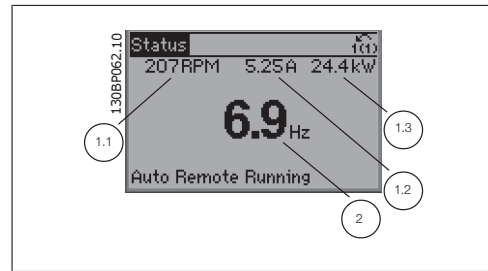

Status display III:

This state displays the event and action of the smart logic control. For further information, see section *Smart Logic Control*.

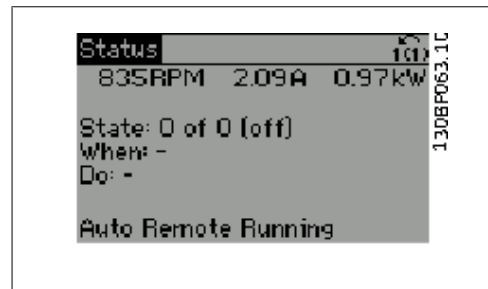

The **Bottom section** always shows the state of the adjustable frequency drive in status mode.

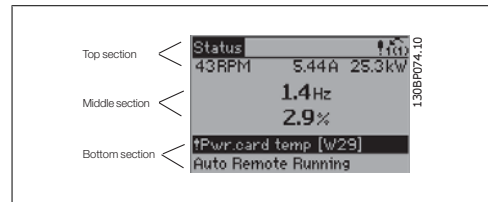

Display Contrast Adjustment

Press [status] and [▲] for darker display
Press [status] and [▼] for brighter display

LEDs:

If certain threshold values are exceeded, the alarm and/or warning LED lights up. A status and alarm text appear on the control panel.

The On LED is activated when the adjustable frequency drive receives power from AC line voltage, a DC bus terminal, or an external 24 V supply. At the same time, the back light is on.

- Green LED/On: Control section is working.
- Yellow LED/Warn.: Indicates a warning.
- Flashing Red LED/Alarm: Indicates an alarm.

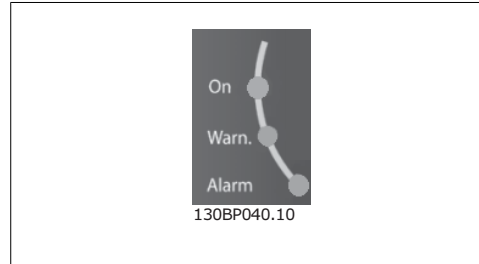

GLCP keys

Menu keys

The menu keys are divided into functions. The keys below the display and LEDs are used for parameter set-up, including display indication selection during normal operation.

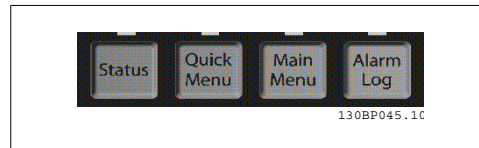

[Status]

indicates the status of the adjustable frequency drive and/or the motor. 3 different readouts can be chosen by pressing the [Status] key:

5 line readouts, 4 line readouts or smart logic control.

Use [Status] for selecting the mode of display or for changing back to display mode from either the quick menu mode, the main menu mode or alarm mode. Also use the [Status] key to toggle single or double readout mode.

[Quick Menu]

Allows quick set-up of the adjustable frequency drive. **The most common AQUA functions can be programmed here.**

The [Quick Menu] consists of:

- **Q1: My Personal Menu**
- **Q2: Quick Set-up**
- **Q3: Function Set-ups**
- **Q5: Changes Made**
- **Q6: Loggings**

The function set-up provides quick and easy access to all parameters required for the majority of water and wastewater applications including variable torque, constant torque, pumps, dosing pumps, well pumps, booster pumps, mixer pumps, aeration blowers and other pump and fan applications. Among other features, it also includes parameters for selecting which variables to display on the LCP, digital preset speeds, scaling of analog references, closed-loop single zone and multi-zone applications and specific functions related to water and wastewater applications.

The quick menu parameters can be accessed immediately unless a password has been created via par. 0-60, 0-61, 0-65 or 0-66.

It is possible to switch directly between Quick Menu mode and Main Menu mode.

[Main Menu]

is used for programming all parameters.

The main menu parameters can be accessed immediately unless a password has been created via par. 0-60, 0-61, 0-65 or 0-66. For the majority of water and wastewater applications it is not necessary to access the main menu parameters, but instead the quick menu, quick set-up and function set-ups provide the simplest and quickest access to the typical required parameters.

It is possible to switch directly between Main Menu mode and Quick Menu mode.

Parameter shortcuts can be carried out by pressing the **[Main Menu]** key for 3 seconds. The parameter shortcut allows direct access to any parameter.

[Alarm Log]

displays an Alarm list of the last five alarms (numbered A1-A5). For additional details on a particular alarm, use the arrow keys to navigate to the alarm number and press [OK]. Information is displayed about the condition of the adjustable frequency drive before it enters Alarm mode.

[Back]

reverts to the previous step or layer in the navigation structure.

[Cancel]

the last change or command will be canceled as long as the display has not been changed.

[Info]

displays information about a command, parameter, or function in any display window. [Info] provides detailed information when needed.

Exit Info mode by pressing either [Info], [Back], or [Cancel].

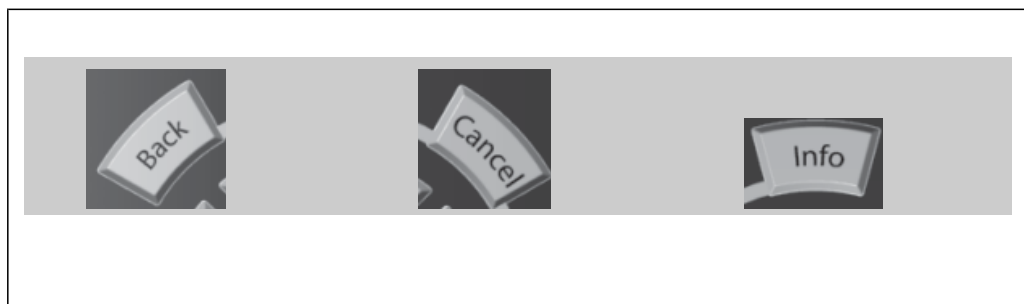

Navigation Keys

The four navigation arrows are used to navigate between the different choices available in **[Quick Menu]**, **[Main Menu]** and **[Alarm Log]**. Use the keys to move the cursor.

[OK] is used for choosing a parameter marked by the cursor and for enabling the change of a parameter.

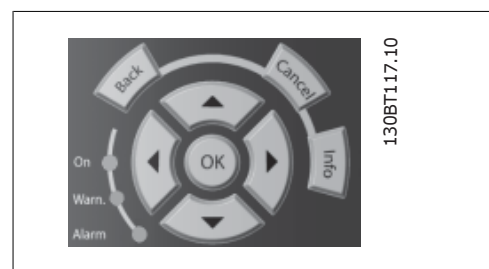

Operation Keys for local control are found at the bottom of the control panel.

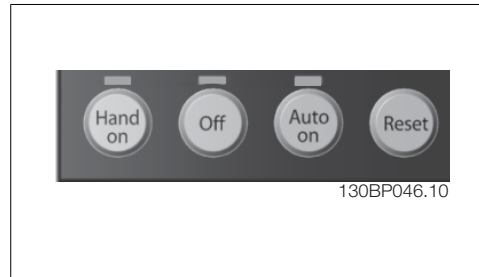

[Hand On]

enables control of the adjustable frequency drive via the GLCP. [Hand on] also starts the motor, and makes it possible to give the motor speed reference using the arrow keys. The key can be *Enabled* [1] or *Disabled* [0] via par. 0-40 [Hand on] Key on LCP.

The following control signals will still be active when [Hand on] is activated:

- [Hand on] - [Off] - [Auto on]
- Reset
- Coasting stop inverse (motor coasting to stop)
- Reversing
- Set-up select lsb - Set-up select msb
- Stop command from serial communication
- Quick stop
- DC brake

NOTE
External stop signals activated by using control signals or serial bus will override a "start" command via the LCP.

[Off]

stops the connected motor. The key can be *Enabled* [1] or *Disabled* [0] via par. 0-41 [Off] key on LCP. If no external stop function is selected, and the [Off] key is inactive, the motor can only be stopped by disconnecting the line power supply.

[Auto On]

enables the adjustable frequency drive to be controlled via the control terminals and/or serial communication. When a start signal is applied to the control terminals and/or the bus, the adjustable frequency drive will start. The key can be *Enabled* [1] or *Disabled* [0] via par. 0-42 [Auto on] key on LCP.

NOTE
An active HAND-OFF-AUTO signal via the digital inputs has higher priority than the control keys [Hand on] – [Auto on].

[Reset]

is used for resetting the adjustable frequency drive after an alarm (trip). The key can be *Enabled* [1] or *Disabled* [0] via par. 0-43 Reset Keys on LCP.

The **parameter shortcut** can be carried out by holding down the [Main Menu] key for 3 seconds. The parameter shortcut allows direct access to any parameter.

6.1.3. How to operate numeric LCP (NLCP)

The following instructions are valid for the NLCP (LCP 101).

The control panel is divided into four functional groups:

1. Numeric display.
2. Menu key and LEDs - changing parameters and switching between display functions.
3. Navigation keys and LEDs.
4. Operation keys and LEDs.

NOTE
Parameter copy is not possible with the Numeric Local Control Panel (LCP101).

Select one of the following modes:

Status Mode: Displays the status of the adjustable frequency drive or the motor.

If an alarm occurs, the NLCP automatically switches to status mode.

A number of alarms can be displayed.

Quick Set-up or Main Menu Mode: Display parameters and parameter settings.

LEDs:

- Green LED/On: Indicates if control section is on.
- Yellow LED/Wrn.: Indicates a warning.
- Flashing red LED/Alarm: Indicates an alarm.

Main Menu is used for programming all parameters.

The parameters can be accessed immediately unless a password has been created via par. 0-60, 0-61, 0-65 or 0-66.

Quick Set-up is used to set up the adjustable frequency drive using only the most essential parameters.

The parameter values can be changed using the up/down arrows when the value is flashing.

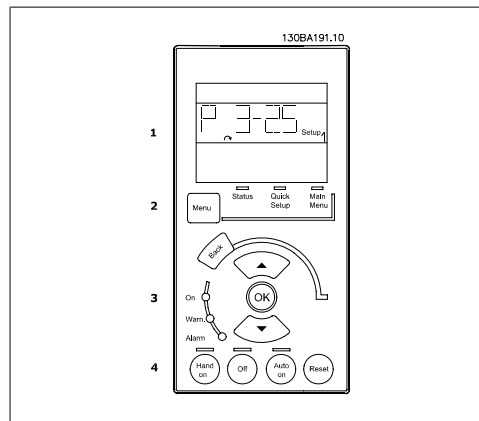

6.1: Numerical LCP (NLCP)

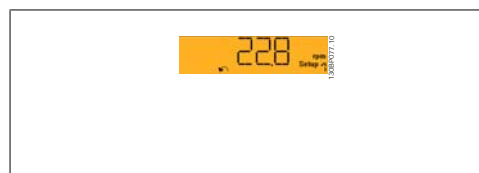

6.2: Status display example

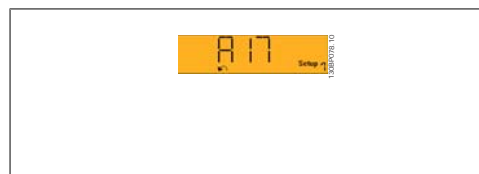

6.3: Alarm display example

Menu key

[Menu] Select one of the following modes:

- Status
- Quick Set-up
- Main Menu

Select the main menu by pressing the [Menu] key a number of times until the main menu LED is lit.

Select the parameter group [xx-__] and press [OK].

Select the parameter [__-xx] and press [OK].

If the parameter is an array parameter, select the array number and press [OK].

Select the desired data value and press [OK].

Navigation Keys [Back] for stepping backwards

Arrow [▼] [▲] keys are used for maneuvering between parameter groups, parameters and within parameters.

[OK] is used for choosing a parameter marked by the cursor and for enabling the change of a parameter.

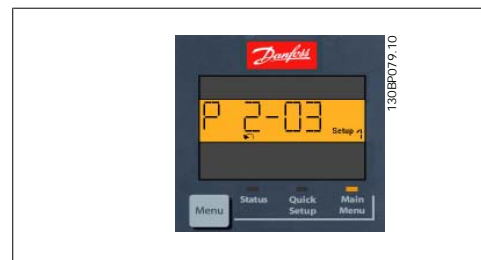

6.4: Display example

Operation Keys

Keys for local control are found at the bottom of the control panel.

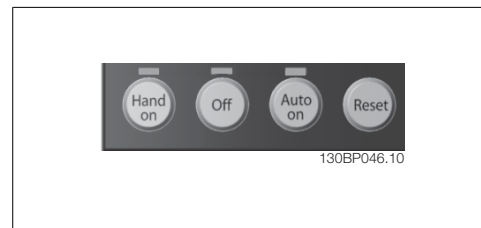

6.5: Operation keys of the Numerical CP (NLCP)

[Hand on] enables control of the adjustable frequency drive via the LCP. [Hand on] also starts the motor and makes it possible to enter the motor speed data by means of the arrow keys. The key can be *Enabled* [1] or *Disabled* [0] via par. 0-40 *[Hand on] key on the LCP*.

External stop signals activated by means of control signals or a serial bus will override a "start" command via the LCP.

The following control signals will still be active when [Hand on] is activated:

- [Hand on] - [Off] - [Auto on]
- Reset
- Coasting stop inverse
- Reversing
- Set-up select lsb - Set-up select msb
- Stop command from serial communication
- Quick stop
- DC brake

[Off] stops the connected motor. The key can be *Enabled* [1] or *Disabled* [0] via par. 0-41 [Off] key on LCP.

If no external stop function is selected, and the [Off] key is inactive, the motor can be stopped by disconnecting the line power supply.

[Auto on] enables the adjustable frequency drive to be controlled via the control terminals and/or serial communication. When a start signal is applied to the control terminals and/or the bus, the adjustable frequency drive will start. The key can be *Enabled* [1] or *Disabled* [0] via par. 0-42 [Auto on] key on LCP.

NOTE
An active HAND-OFF-AUTO signal via the digital inputs has higher priority than the control keys [Hand on] [Auto on].

[Reset] is used for resetting the adjustable frequency drive after an alarm (trip). The key can be *Enabled* [1] or *Disabled* [0] via par. 0-43 *Reset Keys* on LCP.

6.1.4. RS-485 Bus Connection

One or more adjustable frequency drives can be connected to a controller (or master) using the standard RS-485 interface. Terminal 68 is connected to the P signal (TX+, RX+), while terminal 69 is connected to the N signal (TX-, RX-).

If more than one adjustable frequency drive is connected to a master, use parallel connections.

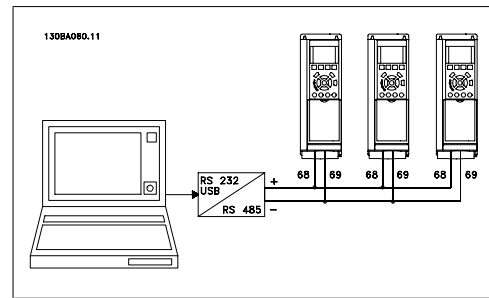

6.6: Connection example.

In order to avoid potential equalizing currents in the shield, ground the cable shield via terminal 61, which is connected to the frame via an RC link.

Bus termination

The RS-485 bus must be terminated by a resistor network at both ends. If the drive is the first or the last device in the RS-485 loop, set the switch S80 on the control card for ON.

For more information, see the paragraph *Switches S201, S202, and S801*.

6.1.5. How to Connect a PC to the Adjustable Frequency Drive

To control or program the adjustable frequency drive from a PC, install the MCT 10 Set-up software on the computer.

The PC is connected via a standard (host/device) USB cable, or via the RS-485 interface as shown in the VLT® AQUA Drive FC 200 Design Guide chapter **How to Install > Installation of misc. connections**.



NOTE

The USB connection is galvanically isolated from the supply voltage (PELV) and other high-voltage terminals. The USB connection is connected to protection ground on the adjustable frequency drive. Use only isolated laptop for PC connection to the USB connector on the adjustable frequency drive.

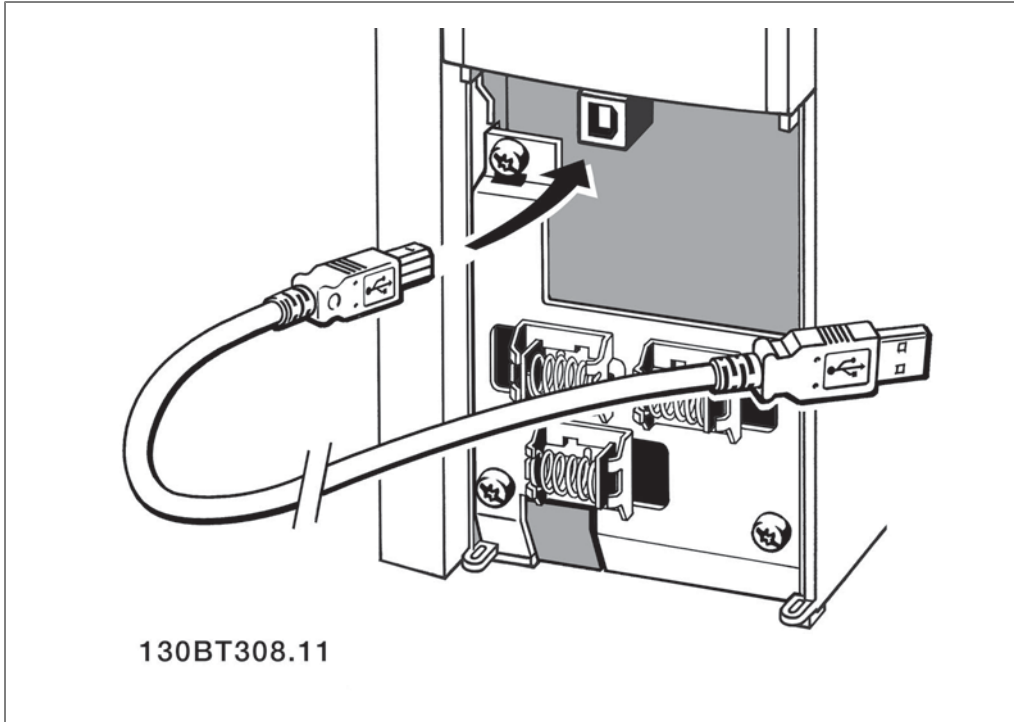

6.7: USB Connection

6.1.6. PC Software tools

PC Software - MCT 10

All adjustable frequency drives are equipped with a serial communication port. Danfoss provides a PC tool for communication between the PC and the adjustable frequency drive, called the VLT Motion Control Tool MCT 10 Set-up software.

MCT 10 Set-up Software

MCT 10 has been designed as an easy-to-use interactive tool for setting parameters in our adjustable frequency drives. The software can be downloaded from the Danfoss homepage at: <http://www.vlt-software.com>.

The MCT 10 Set-up software will be useful for:

- Planning a communication network off-line. The MCT 10 contains a complete adjustable frequency drive database.
- Commissioning adjustable frequency drives on-line.
- Saving settings for all adjustable frequency drives.
- Replacing an adjustable frequency drive in a network.

- Simple and accurate documentation of adjustable frequency drive settings after commissioning.
- Expanding an existing network.
- Adjustable frequency drives developed in the future will be fully supported.

MCT 10 Set-up software support Profibus DP-V1 via a Master class 2 connection. This makes it possible to access on-line read/write parameters in an adjustable frequency drive via the Profibus network. This will eliminate the need for an extra communication network.

Save Adjustable Frequency Drive Settings:

1. Connect a PC to the unit via the USB COM port. (Note: Use a PC that is isolated from the AC line power, in conjunction with the USB port. Failure to do so may result in equipment damage.)
2. Open MCT 10 Set-up software
3. Choose "Read from drive".
4. Choose "Save as".

All parameters are now stored on the PC.

Load Adjustable Frequency Drive Settings:

1. Connect a PC to the adjustable frequency drive via the USB com port
2. Open MCT 10 Set-up software
3. Choose "Open"— stored files will be shown.
4. Open the appropriate file.
5. Choose "Write to drive."

All parameter settings are now transferred to the adjustable frequency drive.

A separate manual for the MCT 10 Set-up software is available: **MG.10.R2.02.**

The MCT 10 Set-up Software Modules

The following modules are included in the software package:

	<p>MCT 10 Set-up Software Setting parameters Copy to and from adjustable frequency drives Documentation and print-out of parameter settings incl. diagrams</p>
	<p>Ext. User Interface Preventive Maintenance Schedule Clock settings Timed Action Programming Smart Logic Controller Set-up Cascade Control Config. Tool</p>

Ordering number:

Please order the CD containing the MCT 10 Set-up software using code number 130B1000.

MCT 10 can also be downloaded from the Danfoss website: www.danfoss.com - Business Area: Motion Controls.

6.1.7. Tips and tricks

- * For the majority of water and wastewater applications, the Quick Menu, Quick Setup and Function Set-ups provide the simplest and quickest access to all of the typical parameters required.
- * Whenever possible, perform an AMA to ensure the best shaft performance
- * Display contrast can be adjusted by pressing [Status] and [▲] for a darker display, or by pressing [Status] and [▼] for a brighter display.
- * Under [Quick Menu] and [Changes Made], all the parameters that have been changed from the factory settings are displayed.
- * Press and hold the [Main Menu] key for 3 seconds to access any parameter.
- * For service purposes, it is recommended to copy all parameters to the LCP; see par 0-50 for further information.

6.1: Tips and tricks

6.1.8. Quick Transfer of Parameter Settings when using GLCP

Once the set-up of an adjustable frequency drive is complete, it is recommended to store (backup) the parameter settings in the GLCP or on a PC via MCT 10 Set-up software tool.



NOTE

Stop the motor before performing any of these operations.

Data storage in LCP:

1. Go to par. 0-50 *LCP Copy*
2. Press the [OK] key.
3. Select "All to LCP"
4. Press the [OK] key.

All the parameter settings are now stored in the GLCP as indicated by the progress bar. When 100% is reached, press [OK].

The GLCP can now be connected to another adjustable frequency drive, and the parameter settings can be copied to this adjustable frequency drive.

Data transfer from LCP to adjustable frequency drive:

1. Go to par. 0-50 *LCP Copy*
2. Press the [OK] key.
3. Select "All from LCP."
4. Press the [OK] key.

The parameter settings stored in the GLCP are now transferred to the adjustable frequency drive, as indicated by the progress bar. When 100% is reached, press [OK].

6.1.9. Initialization to Default Settings

Initialize the adjustable frequency drive using default settings in two ways:

Recommended initialization (via par. 14-22)

1. Select par. 14-22
2. Press [OK]
3. Select "Initialization" (for NLCP select "2")
4. Press [OK]
5. Disconnect the power from the unit and wait for the display to turn off.
6. Reconnecting the power resets the adjustable frequency drive. Please note that the first start-up takes a few more seconds.

Par. 14-22 initializes everything except:	
14-50	<i>RFI 1</i>
8-30	<i>Protocol</i>
8-31	<i>Address</i>
8-32	<i>Baud Rate</i>
8-35	<i>Minimum Response Delay</i>
8-36	<i>Max Response Delay</i>
8-37	<i>Max Inter-char Delay</i>
15-00 to 15-05	Operating data
15-20 to 15-22	Historical log
15-30 to 15-32	Fault log

NOTE
Parameters selected in *Personal Menu*, will stay present with the default factory settings.

Manual initialization

NOTE
When carrying out manual initialization, serial communication, RFI filter settings (par. 14-50) and fault log settings are reset.
Removes parameters selected in *Personal Menu*.

1. Disconnect from the power supply and wait until the display turns off.
 - 2a. Press [Status] - [Main Menu] - [OK] at the same time while powering up the Graphical LCP (GLCP).
 - 2b. Press [Menu] while the LCP 101, Numerical Display is powering up.
 3. Release the keys after 5 s.
 4. The adjustable frequency drive is now programmed according to default settings.

This parameter initializes everything except:

15-00	<i>Operating Hours</i>
15-03	<i>Power-ups</i>
15-04	<i>Overtemps</i>
15-05	<i>Overvolts</i>

7. How to program the adjustable frequency drive

7.1. How to program

7.1.1. Parameter Set-up

Group	Title	Function
0-	Operation/Display	Parameters related to the fundamental functions of the adjustable frequency drive, the functions of the LCP buttons and the configuration of the LCP display.
1-	Load / Motor	Parameter group for motor settings.
2-	Brakes	Parameter group for setting brake features in the adjustable frequency drive.
3-	Reference/Ramps	Parameters for reference handling, defining limitations, and configuring the reaction of the adjustable frequency drive to changes.
4-	Limits/Warnings	Parameter group for configuring limits and warnings.
5-	Digital In/Out	Parameter group for configuring the digital inputs and outputs.
6-	Analog In/Out	Parameter group for configuring the analog inputs and outputs.
8-	Communication and Options	Parameter group for configuring communications and options.
9-	Profibus	Parameter group for Profibus-specific parameters.
10-	DeviceNet Serial Communication Bus	Parameter group for DeviceNet-specific parameters.
11-	LonWorks	Parameter group for LonWorks parameters
13-	Smart Logic	Parameter group for Smart Logic Control
14-	Special Functions	Parameter group for configuring special adjustable frequency drive functions.
15-	Drive Information	Parameter group containing adjustable frequency drive information such as operating data, hardware configuration and software versions.
16-	Data Readouts	Parameter group for data readouts, such as current references, voltages, control, alarm, warning and status words.
18-	Info and Readouts	This parameter group contains the last 10 Preventive Maintenance logs.
20-	Drive Closed-loop	This parameter group is used for configuring the closed-loop PID Controller that controls the output frequency of the unit.
21-	Extended Closed-loop	Parameters for configuring the three extended closed-loop PID controllers.
22-	Application Functions	These parameters monitor water applications.
23-	Time-based Functions	These parameters are for actions to be performed on a daily or weekly basis, such as different references for working hours/non-working hours.
25-	Basic Cascade Controller Functions	Parameters for configuring the Basic Cascade Controller for sequence control of multiple pumps.
26-	Analog I/O Option MCB 109	Parameters for configuring the Analog I/O Option MCB 109.
27-	Extended Cascade Control	Parameters for configuring the extended cascade control.
29-	Water Application Functions	Parameters for setting water specific functions.
31-	Bypass Option	Parameters for configuring the bypass option

7.1: Parameter Groups

Parameter descriptions and selections are displayed on the Graphic LCP or Numeric LCP in the display area (see Section 5 for details.) Access the parameters by pressing the [Quick Menu] or [Main Menu] key on the control panel. The quick menu is used primarily for commissioning the unit at start-up by providing those parameters necessary to commence operations. The main menu provides access to all the parameters for detailed application programming.

All digital input/output and analog input/output terminals are multifunctional. All terminals have factory default functions suitable for the majority of water applications but if other special functions are required, they must be programmed in parameter group 5 or 6.

7.1.2. Quick Menu Mode

The GLCP provides access to all parameters listed under the Quick Menus. The NLCP only provides access to the Quick Setup parameters. To set parameters using the [Quick Menu] button:

Pressing [Quick Menu] the list indicates the different areas contained in the Quick menu.

Efficient Parameter Set-up for Water Applications

The parameters can easily be set up for the vast majority of the water and wastewater applications only by using the [Quick Menu].

The optimum way to set parameters through the [Quick Menu] is by following the below steps:

1. Press [Quick Setup] for selecting basic motor settings, ramp times, etc.
2. Press [Function Setups] for setting up the required functionality of the frequency converter - if not already covered by the settings in [Quick Setup].
3. Choose between *General Settings*, *Open Loop Settings* and *Closed Loop Settings*.

It is recommended to do the set-up in the order listed.

Select *My Personal Menu* to display only the parameters, which have been pre-selected and programmed as personal parameters. For example, a pump or equipment OEM may have pre-programmed these to be in My Personal Menu during factory commissioning to make on site commissioning / fine tuning simpler.. These parameters are selected in parameter 0-25 *My Personal Menu*. Up to 20 different parameters can be defined in this menu.

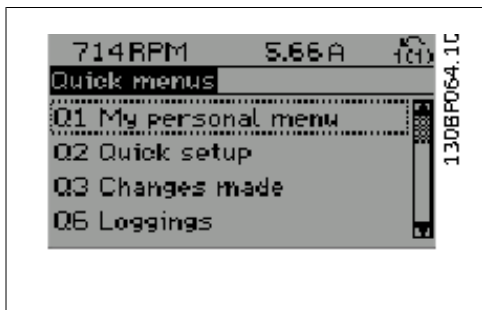

7.1: Quick menu view.

Par.	Designation	[Units]
0-01	Language	
1-20	Motor Power	[kW]
1-22	Motor Voltage	[V]
1-23	Motor Frequency	[Hz]
1-24	Motor Current	[A]
1-25	Motor Nominal Speed	[RPM]
3-41	Ramp 1 Ramp up Time	[s]
3-42	Ramp 1 Ramp down Time	[s]
4-11	Motor Speed Low Limit	[RPM]
4-13	Motor Speed Low High	[RPM]
1-29	Automatic Motor Adaption	[AMA]

7.2: Quick Setup parameters

*The display showing depends on choices made in parameter 0-02 and 0-03. The default setting of parameters 0-02 and 0-03 depends on which region of the world the frequency converter is supplied to but can be re-programmed as required.

If *No Operation* is selected in terminal 27 no connection to +24 V on terminal 27 is necessary to enable start.

If *Coast Inverse* (factory default value) is selected in Terminal 27, a connection to +24V is necessary to enable start.

Select *Changes made* to get information about:

- the last 10 changes. Use the up/down navigation keys to scroll between the last 10 changed parameters.
- the changes made since default setting.

Select *Loggings* to get information about the display line read-outs. The information is shown as graphs.

Only display parameters selected in par. 0-20 and par. 0-24 can be viewed. It is possible to store up to 120 samples in the memory for later reference.

0-01 Language

Option:

Function:

Defines the language to be used in the display.

[0] * English UK

1-20 Motor Power [kW]

Range:

Function:

Size re- [0.12-670 hp [0.09 -
lated* 500 kW]]

Enter the nominal motor power (in kW) according to the motor nameplate data. The default value corresponds to the nominal rated output of the unit.

This parameter cannot be adjusted while the motor is running. Depending on the choices made in par. 0-03 *Regional Settings*, either par. 1-20 or par. 1-21 *Motor Power* is made invisible.

1-22 Motor Voltage

Range:

Function:

Size re- [10 - 1,000 V]
lated*

Enter the nominal motor voltage according to the motor nameplate data. The default value corresponds to the nominal rated output of the unit.

This parameter cannot be adjusted while the motor is running.

1-23 Motor Frequency

Range:

Function:

Size re- [20 - 1000 Hz]
lated*

Select the motor frequency value from the motor nameplate data. For 87 Hz operation with 230/400 V motors, set the nameplate data for 230 V/50 Hz. Adapt par. 4-13 *Motor Speed High Limit [RPM]* and par. 3-03 *Maximum Reference* to the 87 Hz application.

This parameter cannot be adjusted while the motor is running.

1-24 Motor Current

Range:	Function:
Size re- [0.1 - 10,000 A] lated*	Enter the nominal motor current value from the motor nameplate data. This data is used for calculating motor torque, motor thermal protection, etc.

This parameter cannot be adjusted while the motor is running.

1-25 Motor Nominal Speed

Range:	Function:
Size re- [100 - 60,000 rpm] lated*	Enter the nominal motor speed value from the motor nameplate data. This data is used for calculating automatic motor compensations.

This parameter cannot be adjusted while the motor is running.

3-41 Ramp 1 Ramp-up Time

Range:	Function:
3 s* [1 - 3600 s]	Enter the ramp-up time, i.e., the acceleration time from 0 rpm to the rated motor speed $n_{M,N}$ (par. 1-25). Choose a ramp-up time such that the output current does not exceed the current limit in par. 4-18 during ramping. Enter the ramp-up time, i.e., the acceleration time from 0 rpm to the rated motor speed $n_{M,N}$ (par. 1-25)

$$par.3 - 41 = \frac{t_{acc} \times n_{norm}[par.1 - 25]}{\Delta ref[rpm]} [s]$$

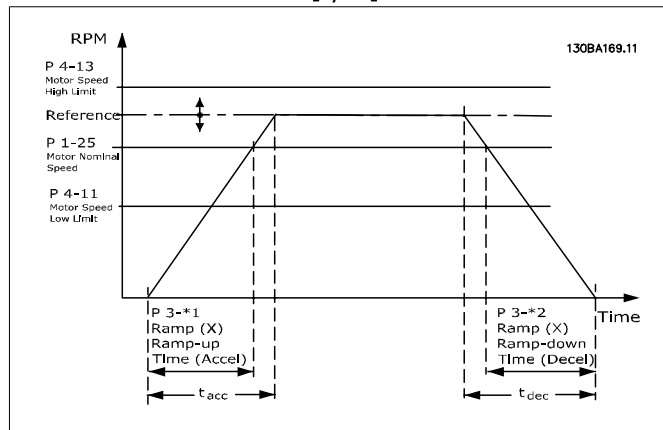

3-42 Ramp 1 Ramp-down Time

Range:
3 s* [1 - 3,600 s]

Function:
Enter the ramp-down time, i.e., the deceleration time from the rated motor speed $n_{M,N}$ (par. 1-25) to 0 rpm. Choose a ramp-down time so that no overvoltage arises in the inverter due to regenerative operation of the motor, and so that the generated current does not exceed the current limit set in par. 4-18. See ramp-up time in par. 3-41.

$$par.3 - 42 = \frac{t_{dec} \times n_{norm} [par.1 - 25]}{\Delta ref [rpm]} [s]$$

4-11 Motor Speed Low Limit [RPM]

Range:
Size re- [0 - 60,000 rpm]
lated*

Function:
Enter the minimum limit for motor speed. The Motor Speed Low Limit can be set to correspond to the manufacturer's recommended minimum motor speed. The Motor Speed Low Limit must not exceed the setting in par. 4-13 *Motor Speed High Limit [RPM]*.

4-13 Motor Speed High Limit [RPM]

Range:
Size re- [0 - 60,000 rpm]
lated*

Function:
Enter the maximum limit for motor speed. The Motor Speed High Limit can be set to correspond to the manufacturer's maximum rated motor speed. The Motor Speed High Limit must exceed the setting in par. 4-11 *Motor Speed Low Limit [RPM]*. Only par. 4-11 or 4-12 will be displayed depending on other parameters set in the Main Menu, and depending on default settings specific to global geographical locations.



NOTE
The output frequency value of the adjustable frequency drive must not exceed a value higher than 1/10 of the switching frequency.

1-29 Automatic Motor Adaptation (AMA)

Option:

Function:
The AMA function optimizes dynamic motor performance by automatically optimizing the advanced motor parameters (par. 1-30 to par. 1-35) while the motor is stationary.

[0] *	OFF	No function
[1]	Enable complete AMA	performs AMA of the stator resistance R_s , the rotor resistance R_r , the stator leakage reactance X_{1l} , the rotor leakage reactance X_{2l} and the main reactance X_h .

[2] Enable reduced AMA performs a reduced AMA of the stator resistance R_s in the system only. Select this option if an LC filter is used between the adjustable frequency drive and the motor.

Activate the AMA function by pressing [Hand on] after selecting [1] or [2]. See also the section *Automatic Motor Adaptation*. After a normal sequence, the display will read: "Press [OK] to finish AMA". After pressing the [OK] key, the adjustable frequency drive is ready for operation.

Note:

- For the best adaptation of the adjustable frequency drive, run the AMA on a cold motor.
- AMA cannot be performed while the motor is spinning.



NOTE

It is important to set motor par. 1-2* Motor Data correctly, since these form part of the AMA algorithm. An AMA must be performed to achieve optimum dynamic motor performance. It may take up to 10 min, depending on the power rating of the motor.



NOTE

Avoid generating external torque during AMA.



NOTE

If one of the settings in par. 1-2* Motor Data is changed, par. 1-30 to 1-39, the advanced motor parameters, will return to default setting. This parameter cannot be adjusted while the motor is running.

See section *Automatic Motor Adaptation* - application example.

7.1.3. Function Set-ups

The function set-up provides quick and easy access to all parameters required for the majority of water and wastewater applications including variable torque, constant torque, pumps, dosing pumps, well pumps, booster pumps, mixer pumps, aeration blowers and other pump and fan applications. Among other features, it also includes parameters for selecting which variables to display on the LCP, digital preset speeds, scaling of analog references, closed-loop single zone and multi-zone applications and specific functions related to water and wastewater applications.

How to access Function Set-up - example

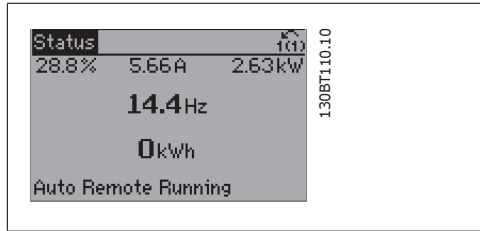

7.2: Step 1: Turn on the adjustable frequency drive (on LED lights).

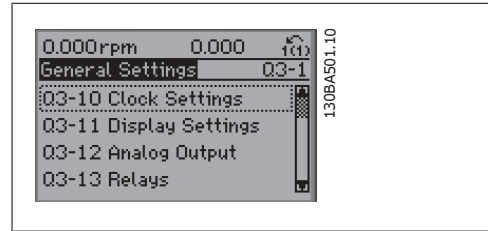

7.6: Step 5: Use the up/down navigation keys to scroll down to, e.g., 03-12 *Analog Outputs*. Press [OK].

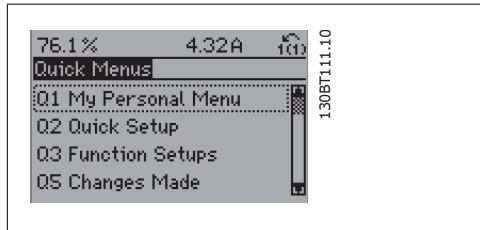

7.3: Step 2: Press the [Quick Menus] button (quick menu choices appear).

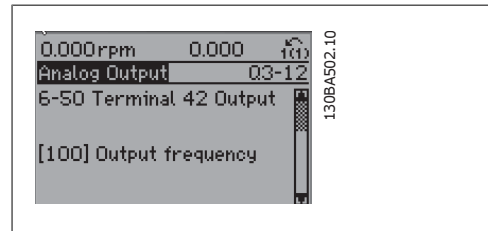

7.7: Step 6: Choose parameter 6-50 *Terminal 42 Output*. Press [OK].

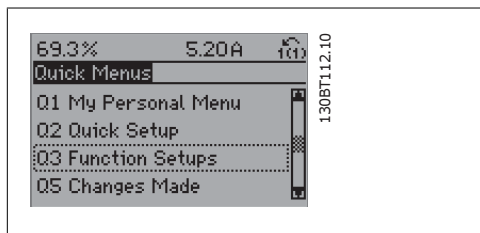

7.4: Step 3: Use the up/down navigation keys to scroll down to Function Set-ups. Press [OK].

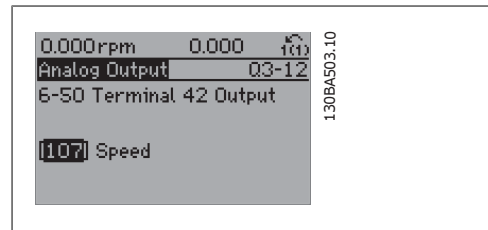

7.8: Step 7: Use the up/down navigation keys to select between the different choices. Press [OK].

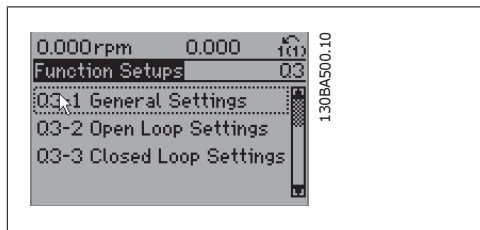

7.5: Step 4: Function Set-ups choices appear. Choose 03-1 *General Settings*. Press [OK].

The function set-up parameters are grouped in the following way:

Q3-1 General Settings			
Q3-10 Clock Settings	Q3-11 Display Settings	Q3-12 Analog Output	Q3-13 Relays
0-70 Set Date and Time	0-20 Display Line 1.1 Small	6-50 Terminal 42 Output	Relay 1 ⇒ 5-40 Function Relay
0-71 Date Format	0-21 Display Line 1.2 Small	6-51 Terminal 42 Output Min Scale	Relay 2 ⇒ 5-40 Function Relay
0-72 Time Format	0-22 Display Line 1.3 Small	6-52 Terminal 42 Output Max Scale	Option relay 7 ⇒ 5-40 Function Relay
0-74 DST/Summertime	0-23 Display Line 2 Large		Option relay 8 ⇒ 5-40 Function Relay
0-76 DST/Summertime Start	0-24 Display Line 3 Large		Option relay 9 ⇒ 5-40 Function Relay
0-77 DST/Summertime End	0-37 Display Text 1		
	0-38 Display Text 2		
	0-39 Display Text 3		

Q3-2 Open-loop Settings	
Q3-20 Digital Reference	Q3-21 Analog Reference
3-02 Minimum Reference	3-02 Minimum Reference
3-03 Maximum Reference	3-03 Maximum Reference
3-10 Preset Reference	6-10 Terminal 53 Low Voltage
5-13 Terminal 29 Digital Input	6-11 Terminal 53 High Voltage
5-14 Terminal 32 Digital Input	6-14 Terminal 53 Low Ref/Feedb. Value
5-15 Terminal 33 Digital Input	6-15 Terminal 53 High Ref/Feedb. Value

Q3-3 Closed-loop Settings	
Q3-30 Feedback Settings	Q3-31 PID Settings
1-00 Configuration Mode	20-81 PID Normal/Inverse Control
20-12 Reference/Feedb.Unit	20-82 PID Start Speed [RPM]
3-02 Minimum Reference	20-21 Setpoint 1
3-03 Maximum Reference	20-93 PID Proportional Gain
6-20 Terminal 54 Low Voltage	20-94 PID Integral Time
6-21 Terminal 54 High Voltage	
6-24 Terminal 54 Low Ref/Feedb Value	
6-25 Terminal 54 High Ref/Feedb Value	
6-00 Live Zero Timeout Time	
6-01 Live Zero Timeout Function	

0-20 Display Line 1.1 Small

Option:

Function:

Select a variable for display in line 1, left position.

[0]	None	No display value selected
[37]	Display Text 1	Present control word
[38]	Display Text 2	Enables an individual text string to be written for display in the LCP or to be read via serial communication.

[39]	Display Text 3		Enables an individual text string to be written for display in the LCP or to be read via serial communication.
[89]	Date and Time Readout		Displays the current date and time.
[953]	Profibus Warning Word		Displays Profibus communication warnings.
[1005]	Readout Transmit Error Counter		View the number of CAN control transmission errors since the last power-up.
[1006]	Readout Receive Error Counter		View the number of CAN control receipt errors since the last power-up.
[1007]	Readout Bus Off Counter		View the number of Bus Off events since the last power-up.
[1013]	Warning Parameter		View a DeviceNet-specific warning word. One separate bit is assigned to every warning.
[1115]	LON Warning Word		Shows the LON-specific warnings.
[1117]	XIF Revision		Shows the version of the external interface file of the Neuron C chip on the LON option.
[1118]	LON Works Revision		Shows the software version of the application program of the Neuron C chip on the LON option.
[1501]	Running Hours		View the number of running hours of the motor.
[1502]	kWh Counter		View the line power consumption in kWh.
[1600]	Control Word		View the control word sent from the adjustable frequency drive via the serial communication port in hex code.
[1601]	* Reference [Unit]		Total reference (sum of digital/analog/preset/bus/freeze ref./catch up and slow-down) in selected unit.
[1602]	Reference %		Total reference (sum of digital/analog/preset/bus/freeze ref./catch up and slow-down) in percent.
[1603]	Status Word		Present status word
[1605]	Main Actual Value [%]		One or more warnings in hex code.
[1609]	Custom Readout		View the user-defined readouts as defined in par. 0-30, 0-31 and 0-32.
[1610]	Power [kW]		Actual power consumed by the motor in kW.
[1611]	Power [HP]		Actual power consumed by the motor in HP.
[1612]	Motor Voltage		Voltage supplied to the motor.
[1613]	Motor Frequency		Motor frequency, i.e., the output frequency from the adjustable frequency drive in Hz.
[1614]	Motor Current		Phase current of the motor measured as effective value.

[1615]	Frequency [%]	Motor frequency, i.e., the output frequency from the adjustable frequency drive in percent.
[1616]	Torque [Nm]	Present motor load as a percentage of the rated motor torque.
[1617]	Speed [RPM]	Speed in RPM (revolutions per minute), i.e., the motor shaft speed in closed-loop based on the entered motor nameplate data, the output frequency and the load on the adjustable frequency drive.
[1618]	Motor Thermal	Thermal load on the motor, calculated by the ETR function. See also parameter group 1-9* Motor Temperature.
[1622]	Torque [%]	Shows the actual torque produced, in percentage.
[1630]	DC Link Voltage	Intermediate circuit voltage in the adjustable frequency drive.
[1632]	Brake Energy/s	Present braking energy transferred to an external brake resistor. Stated as an instantaneous value.
[1633]	Brake Energy/2 min	Braking energy transferred to an external brake resistor. The mean power is calculated continuously for the latest 120 seconds.
[1634]	Heatsink Temp.	Present heat sink temperature of the adjustable frequency drive. The cut-out limit is $203 \pm 9^{\circ}\text{F}$ [$95 \pm 5^{\circ}\text{C}$]; cutting back in occurs at $158 \pm 9^{\circ}\text{F}$ [$70 \pm 5^{\circ}\text{C}$].
[1635]	Thermal Drive Load	Percentage load of the inverters.
[1636]	Inv. Nom. Current	Nominal current of the adjustable frequency drive.
[1637]	Inv. Max. Current	Maximum current of the adjustable frequency drive.
[1638]	SL Control State	State of the event executed by the control.
[1639]	Control Card Temp.	Temperature of the control card.
[1650]	External Reference	Sum of the external reference as a percentage, i.e., the sum of analog/pulse/bus.
[1652]	Feedback [Unit]	Signal value in units from the programmed digital input(s).
[1653]	DigiPot Reference	View the contribution of the digital potentiometer to the actual reference feedback.
[1654]	Feedback 1 [Unit]	View the value of Feedback 1. See also par. 20-0*.
[1655]	Feedback 2 [Unit]	View the value of Feedback 2. See also par. 20-0*.
[1656]	Feedback 3 [Unit]	View the value of Feedback 3. See also par. 20-0*.
[1660]	Digital Input	Displays the status of the 6 digital input terminals (18, 19, 27, 29, 32 and 33). Input 18 corresponds to the bit at the far left. Signal low = 0; Signal high = 1
[1661]	Terminal 53 Switch Setting	Setting of input terminal 53. Current = 0; Voltage = 1.

[1662]	Analog Input 53		Actual value at input 53 either as a reference or protection value.
[1663]	Terminal 54	Switch Setting	Setting of input terminal 54. Current = 0; Voltage = 1.
[1664]	Analog Input 54		Actual value at input 54 either as reference or protection value.
[1665]	Analog Output [mA]	42	Actual value at output 42 in mA. Use par. 6-50 to select the variable to be represented by output 42.
[1666]	Digital Output [bin]		Binary value of all digital outputs.
[1667]	Freq. Input #29 [Hz]		Actual value of the frequency applied at terminal 29 as a pulse input.
[1668]	Freq. Input #33 [Hz]		Actual value of the frequency applied at terminal 33 as a pulse input.
[1669]	Pulse Output [Hz]	#27	Actual value of pulses applied to terminal 27 in digital output mode.
[1670]	Pulse Output [Hz]	#29	Actual value of pulses applied to terminal 29 in digital output mode.
[1671]	Relay Output [bin]		View the setting of all relays.
[1672]	Counter A		View the present value of Counter A.
[1673]	Counter B		View the present value of Counter B.
[1675]	Analog input X30/11		Actual value of the signal on input X30/11 (General Purpose I/O Card. Option)
[1676]	Analog input X30/12		Actual value of the signal on input X30/12 (General Purpose I/O Card. Optional)
[1677]	Analog output [mA]	X30/8	Actual value at output X30/8 (General Purpose I/O Card. Optional) Use Par. 6-60 to select the variable to be shown.
[1680]	Ser. Com. Bus CTW 1		Control word (CTW) received from the bus master.
[1682]	Ser. com. bus REF 1		Main reference value sent with control word via the serial communications network, such as from the BMS, PLC or other master controller, for example.
[1684]	Comm. Option STW		Extended serial communication bus option status word.
[1685]	FC Port CTW 1		Control word (CTW) received from the bus master.
[1686]	FC Port REF 1		Status word (STW) sent to the bus master.
[1690]	Alarm Word		One or more alarms in a Hex code (used for serial communications).
[1691]	Alarm Word 2		One or more alarms in a Hex code (used for serial communications).
[1692]	Warning Word		One or more warnings in a Hex code (used for serial communications).

[1693]	Warning Word 2	One or more warnings in a Hex code (used for serial communications).
[1694]	Ext. Status Word	One or more status conditions in a Hex code (used for serial communications)
[1695]	Ext. Status Word 2	One or more status conditions in a Hex code (used for serial communications)
[1696]	Maintenance Word	The bits reflect the status for the programmed preventive maintenance events in parameter group 23-1*.
[1830]	Analog Input X42/1	Shows the value of the signal applied to terminal X42/1 on the analog I/O card.
[1831]	Analog Input X42/3	Shows the value of the signal applied to terminal X42/3 on the analog I/O card.
[1832]	Analog Input X42/5	Shows the value of the signal applied to terminal X42/5 on the analog I/O card.
[1833]	Analog Out X42/7 [V]	Shows the value of the signal applied to terminal X42/7 on the analog I/O card.
[1834]	Analog Out X42/9 [V]	Shows the value of the signal applied to terminal X42/9 on the analog I/O card.
[1835]	Analog Out X42/11 [V]	Shows the value of the signal applied to terminal X42/11 on the analog I/O card.
[2117]	Ext. 1 Reference [Unit]	The value of the reference for extended closed-loop controller 1.
[2118]	Ext. 1 Feedback [Unit]	The value of the feedback signal for extended closed-loop controller 1.
[2119]	Ext. 1 Output [%]	The value of the output from extended closed-loop controller 1.
[2137]	Ext. 2 Reference [Unit]	The value of the reference for extended closed-loop controller 2.
[2138]	Ext. 2 Feedback [Unit]	The value of the feedback signal for extended closed-loop controller 2.
[2139]	Ext. 2 Output [%]	The value of the output from extended closed-loop controller 2.
[2157]	Ext. 3 Reference [Unit]	The value of the reference for extended closed-loop controller 3.
[2158]	Ext. 3 Feedback [Unit]	The value of the feedback signal for extended closed-loop controller 3.
[2159]	Ext. Output [%]	The value of the output from extended closed-loop controller 3.
[2230]	No-Flow Power	The calculated no-flow power for the actual operating speed.
[2580]	Cascade Status	Status for the operation of the cascade controller.

[2581] Pump Status	Status for the operation of each individual pump controlled by the cascade controller.
--------------------	--



NOTE

Please consult the VLT® AQUA Drive Programming Guide, MG.20.OX.YY for detailed information.

0-21 Display Line 1.2 Small

Option:	Function:
	Select a variable for display in line 1, middle position.

[1662] * Analog input 53	The options are the same as those listed for par. 0-20 <i>Display Line 1.1 Small</i> .
--------------------------	--

0-22 Display Line 1.3 Small

Option:	Function:
	Select a variable for display in line 1, right position.

[1614] * Motor Current	The options are the same as those listed for par. 0-20 <i>Display Line 1.1 Small</i> .
------------------------	--

0-23 Display Line 2 Large

Option:	Function:
	Select a variable for display in line 2. The options are the same as those listed for par. 0-20 <i>Display Line 1.1 Small</i> .

[1615] * Frequency	
--------------------	--

0-24 Display Line 3 Large

Option:	Function:
[1652] * Feedback [Unit]	Select a variable for display in line 2. The options are the same as those listed for par. 0-20 <i>Display Line 1.1 Small</i> .

0-37 Display Text 1

Option:	Function:
	In this parameter, it is possible to write an individual text string for display in the LCP or to be read via serial communication. If to be displayed permanently select Display Text 1 in par. 0-20, 0-21, 0-22, 0-23 or 0-24, <i>Display Line XXX</i> . Use the ▲ or ▼ buttons on the LCP to change a character. Use the ◀ and ▶ buttons to move the cursor. When a character is highlighted by the cur-

sor, it can be changed. Use the ▲ or ▼ buttons on the LCP to change a character. A character can be inserted by placing the cursor between two characters and pressing ▲ or ▼.

0-38 Display Text 2

Option:

Function:

In this parameter, it is possible to write an individual text string for display in the LCP or to be read via serial communication. If to be displayed permanently, select Display Text 2 in par. 0-20, 0-21, 0-22, 0-23 or 0-24, *Display Line XXX*. Use the ▲ or ▼ buttons on the LCP to change a character. Use the ◀ and ▶ buttons to move the cursor. When a character is highlighted by the cursor, this character can be changed. A character can be inserted by placing the cursor between two characters and pressing ▲ or ▼.

0-39 Display Text 3

Option:

Function:

In this parameter, it is possible to write an individual text string for display in the LCP or to be read via serial communication. If to be displayed permanently, select Display Text 3 in par. 0-20, 0-21, 0-22, 0-23 or 0-24, *Display Line XXX*. Use the ▲ or ▼ buttons on the LCP to change a character. Use the ◀ and ▶ buttons to move the cursor. When a character is highlighted by the cursor, this character can be changed. A character can be inserted by placing the cursor between two characters and pressing ▲ or ▼.

0-70 Set Date and Time

Range:

2000-01 [2000-01-01 00:00]
-01
00:00 –
2099-12
-01
23:59 *

Function:

Sets the date and time of the internal clock. The format to be used is set in par. 0-71 and 0-72.



NOTE

This parameter does not display the actual time. This can be read in par. 0-89. The clock will not begin counting until a setting different from default has been made.

0-71 Date Format

Option:

[0] * YYYY-MM-DD

Function:

Sets the date format to be used in the LCP.

[1]	DD-MM-YYYY	Sets the date format to be used in the LCP.
[2]	MM/DD/YYYY	Sets the date format to be used in the LCP.

0-72 Time Format

Option:
Function:
Sets the time format to be used in the LCP.

[0] *	24 H
[1]	12 H

0-74 DST/Summertime

Option:
Function:
Choose how Daylight Saving Time/Summertime should be handled. For manual DST/Summertime, enter the start date and end date in par. 0-76 and 0-77.

[0] *	OFF
[2]	Manual

0-76 DST/Summertime Start

Range:
2000-01 [2000-01-01 00:00 – 2099-12-31 23:59] 00:00*
Function:
Sets the date and time when Summertime/DST starts. The date is programmed in the format selected in par. 0-71.

0-77 DST/Summertime End

Range:
2000-01 [2000-01-01 00:00 – 2099-12-31 23:59] 00:00*
Function:
Sets the date and time when Summertime/DST ends. The date is programmed in the format selected in par. 0-71.

1-00 Configuration Mode

Option:
[0] * Open-loop
Function:
Motor speed is determined by applying a speed reference or by setting desired speed when in hand mode. Open-loop is also used if the adjustable frequency drive is part of a closed-loop control system based on an external PID controller providing a speed reference signal as output.

[3]	Closed-loop	Motor speed will be determined by a reference from the built-in PID controller varying the motor speed as part of a closed-loop control process (e.g., constant pressure or flow). The PID controller must be configured in par. 20-**, Drive Closed-loop or
-----	-------------	--

via the function set-ups accessed by pressing the [Quick Menus] button.

This parameter cannot be changed while the motor is running.

 **NOTE**
When set for closed-loop, the commands reversing and start reversing will not reverse the direction of the motor.

3-02 Minimum Reference

Range:	Function:
0.000 [-100000.000 – par. 3-03] Unit* 3-03]	Enter the Minimum Reference. The Minimum Reference is the lowest value obtainable by adding all references together.

3-03 Maximum Reference

Option:	Function:
[0.000 Par. 3-02] Unit] * 100000.000	- Enter the maximum reference. The maximum reference is the highest value obtainable by adding all references together.

3-10 Preset Reference

Array [8]

0.00%* [-100.00 - 100.00 %] Enter up to eight different preset references (0-7) in this parameter using array programming. The preset reference is stated as a percentage of the value Ref_{MAX} (par. 3-03 *Maximum Reference*) or as a percentage of the other external references. If a Ref_{MIN} different from 0 (Par. 3-02 *Minimum Reference*) is programmed, the preset reference is calculated as a percentage of the full reference range, i.e., on the basis of the difference between Ref_{MAX} and Ref_{MIN}. Afterwards, the value is added to Ref_{MIN}. When using preset references, select Preset ref. bit 0 / 1 / 2 [16], [17] or [18] for the corresponding digital inputs in parameter group 5.1* Digital Inputs.

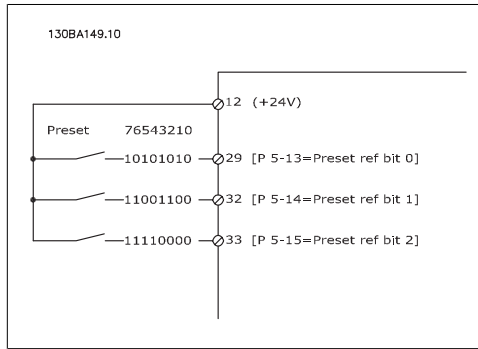

5-13 Terminal 29 Digital Input

Option: [0] * No Operation **Function:** Same options and functions as par. 5-1* *Digital Inputs*.

5-14 Terminal 32 Digital Input

Option: [0] * No Operation **Function:** Same options and functions as par. 5-1* *Digital Inputs*, except for *Pulse input*.

5-15 Terminal 33 Digital Input

Option: [0] * No Operation **Function:** Same options and functions as par. 5-1* *Digital Inputs*.

5-40 Function Relay

Array [8]	(Relay 1 [0], Relay 2 [1], Relay 7 [6], Relay 8 [7], Relay 9 [8])
-----------	---

Select options to define the function of the relays.
The selection of each mechanical relay is realized in an array parameter.

- [0] No Operation
- [1] Control Ready
- [2] Drive Ready
- [3] Drive Ready/Remote
- [4] Stand-by/No Warning
- [5] * Running
- [6] Running/No Warning
- [8] Run on Ref./No Warning

[9]	Alarm
[10]	Alarm or Warning
[11]	At Torque Limit
[12]	Out of Current Range
[13]	Below Current, low
[14]	Above Current, high
[15]	Out of Speed Range
[16]	Below Speed, low
[17]	Above Speed, high
[18]	Out of Feedb. Range
[19]	Below Feedback, low
[20]	Above Feedback, high
[21]	Thermal Warning
[25]	Reverse
[26]	Bus OK
[27]	Torque Limit & Stop
[28]	Brake, No Warning
[29]	Brake Ready, No Fault
[30]	Brake Fault (IGBT)
[35]	External Interlock
[36]	Control Word Bit 11
[37]	Control Word Bit 12
[40]	Out of Ref. Range
[41]	Below Reference, low
[42]	Above Ref. high
[45]	Bus ctrl
[46]	Bus ctrl, 1 if timeout
[47]	Bus ctrl, 0 if timeout
[60]	Comparator 0
[61]	Comparator 1
[62]	Comparator 2
[63]	Comparator 3
[64]	Comparator 4
[65]	Comparator 5
[70]	Logic Rule 0
[71]	Logic Rule 1
[72]	Logic Rule 2
[73]	Logic Rule 3
[74]	Logic Rule 4
[75]	Logic Rule 5
[80]	SL Digital Output A
[81]	SL Digital Output B

[82]	SL Digital Output C
[83]	SL Digital Output D
[84]	SL Digital Output E
[85]	SL Digital Output F
[160]	No Alarm
[161]	Running Reverse
[165]	Local Ref. Active
[166]	Remote Ref. Active
[167]	Start Cmd. Active
[168]	Drive in Hand Mode
[169]	Drive in Auto Mode
[180]	Clock Fault
[181]	Prev. Maintenance
[190]	No-Flow
[191]	Dry Pump
[192]	End of Curve
[193]	Sleep Mode
[194]	Broken Belt
[195]	Bypass Valve Control
[196]	Pipe Filling
[211]	Cascade Pump1
[212]	Cascade Pump2
[213]	Cascade Pump3
[223]	Alarm, Trip-locked
[224]	Bypass Mode Active

6-00 Live Zero Timeout Time

Range: 10 s* [1 - 99 s]	Function: Enter the Live Zero Timeout time period. Live Zero Timeout Time is active for analog inputs, (i.e., terminal 53 or terminal 54), allocated to current and used as reference or feedback sources. If the reference signal value associated with the selected current input falls below 50% of the value set in par. 6-10, par. 6-12, par. 6-20 or par. 6-22 for a period of time longer than that set in par. 6-00, the function selected in par. 6-01 will be activated.
-----------------------------------	--

6-01 Live Zero Timeout Function

Option:	Function: Select the timeout function. The function set in par. 6-01 will be activated if the input signal on terminal 53 or 54 is below 50%
----------------	--

of the value in par. 6-10, par. 6-12, par. 6-20 or par. 6-22 for a time period defined in par. 6-00. If several timeouts occur simultaneously, the adjustable frequency drive prioritizes the timeout functions as follows:

1. Par. 6-01 *Live Zero Timeout Function*
2. Par. 8-04 *Control Word Timeout Function*

The output frequency of the adjustable frequency drive can be:

- [1] frozen at the present value
- [2] overruled to stop
- [3] overruled to jog speed
- [4] overruled to max. speed
- [5] overruled to stop with subsequent trip

If you select set-up 1-4, par. 0-10, *Active Set-up*, must be set to *Multi Set-up*, [9].

This parameter cannot be adjusted while the motor is running.

[0] *	Off
[1]	Freeze output
[2]	Stop
[3]	Jogging
[4]	Max. speed
[5]	Stop and trip

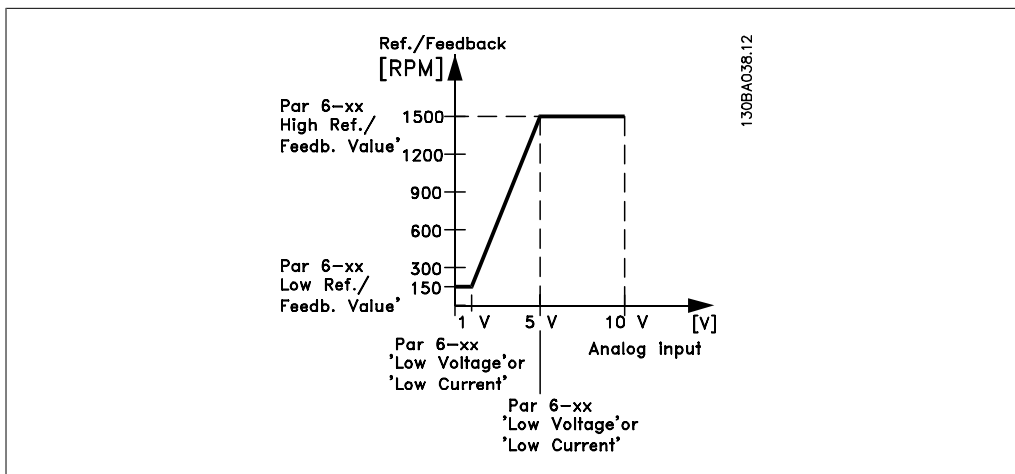

6-10 Terminal 53 Low Voltage

Range: 0.07V* [0.00 - par. 6-11] **Function:** Enter the low voltage value. This analog input scaling value should correspond to the low reference/feedb. value set in par. 6-14.

6-11 Terminal 53 High Voltage

Range:	Function:
10.0 V* [Par. 6-10 to 10.0 V]	Enter the high voltage value. This analog input scaling value should correspond to the high reference/feedback value set in par. 6-15.

6-14 Terminal 53 Low Ref./Feedb. Value

Range:	Function:
0.000 [-1000000.000 to par. Unit* 6-15]	Enter the analog input scaling value that corresponds to the low voltage/low current set in par. 6-10 and 6-12.

6-15 Terminal 53 High Ref./Feedb. Value

Range:	Function:
100.000 [Par. 6-14 to Unit* 1,000,000.000]	Enter the analog input scaling value that corresponds to the high voltage/high current value set in par. 6-11/6-13.

6-20 Terminal 54 Low Voltage

Range:	Function:
0.07V* [0.00 – par. 6-21]	Enter the low voltage value. This analog input scaling value should correspond to the low reference/feedback value set in par. 6-24.

6-21 Terminal 54 High Voltage

Range:	Function:
10.0 V* [Par. 6-20 to 10.0 V]	Enter the high voltage value. This analog input scaling value should correspond to the high reference/feedback value set in par. 6-25.

6-24 Terminal 54 Low Ref./Feedb. Value

Range:	Function:
0.000 [-1,000,000.000 to Unit* par. 6-25]	Enter the analog input scaling value that corresponds to the low voltage/low current value set in par. 6-20/6-22.

6-25 Terminal 54 high ref./feedb. value

Range:	Function:
100.000 [Par. 6-24 to Unit* 1,000,000.000]	Enter the analog input scaling value that corresponds to the high voltage/high current value set in par. 6-21/6-23.

6-50 Terminal 42 Output

Option:	Function:
[0] No operation	

[100] *	Output frequency
[101]	Reference
[102]	Feedback
[103]	Motor current
[104]	Torque rel to lim
[105]	Torque rel to rated
[106]	Power
[107]	Speed
[108]	Torque
[113]	Ext. closed-loop 1
[114]	Ext. closed-loop 2
[115]	Ext. closed-loop 3
[130]	Output freq. 4-20 mA
[131]	Reference 4-20 mA
[132]	Feedback 4-20 mA
[133]	Motor cur. 4-20 mA
[134]	Torque % lim. 4-20 mA
[135]	Torque % nom 4-20 mA
[136]	Power 4-20 mA
[137]	Speed 4-20 mA
[138]	Torque 4-20 mA
[139]	Bus ctrl. 0-20 mA
[140]	Bus ctrl. 4-20 mA
[141]	Bus ctrl. 0-20 mA, timeout
[142]	Bus ctrl. 4-20 mA, timeout
[143]	Ext. Closed-loop 1, 4-20 mA
[144]	Ext. Closed-loop 2, 4-20 mA
[145]	Ext. Closed-loop 3, Select the function of terminal 42 as an analog current output. 4-20 mA

6-51 Terminal 42 Output Min Scale

Range:

0%* [0 – 200%]

Function:

Scale the minimum output of the selected analog signal at terminal 42, as a percentage of the maximum signal value. For example, if 0 mA (or 0 Hz) is desired at 25% of the maximum output value, program it to 25%. Scaling values up to 100% can never be higher than the corresponding setting in par. 6-52.

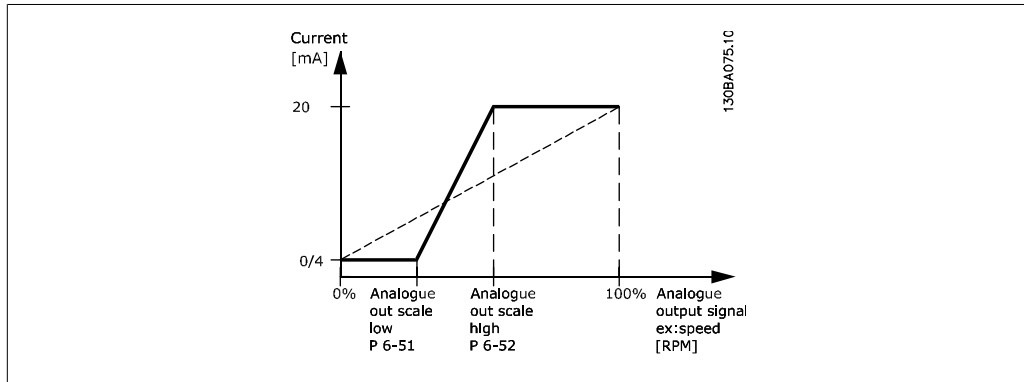

6-52 Terminal 42 Output Max Scale

Range:
100%* [0.00 – 200%]

Function:
Scale the maximum output of the selected analog signal at terminal 42. Set the value to the maximum value of the current signal output. Scale the output to give a current lower than 20 mA at full scale; or 20 mA at an output below 100% of the maximum signal value. If 20 mA is the desired output current at a value between 0 - 100% of the full-scale output, program the percentage value in the parameter, i.e., 50% = 20 mA. If a current between 4 and 20 mA is desired at maximum output (100%), calculate the percentage value as follows:

$$20 \text{ mA} / \text{desired maximum current} \times 100 \%$$

i.e. 10 mA: $\frac{20 \text{ mA}}{10 \text{ mA}} \times 100 \% = 200 \%$

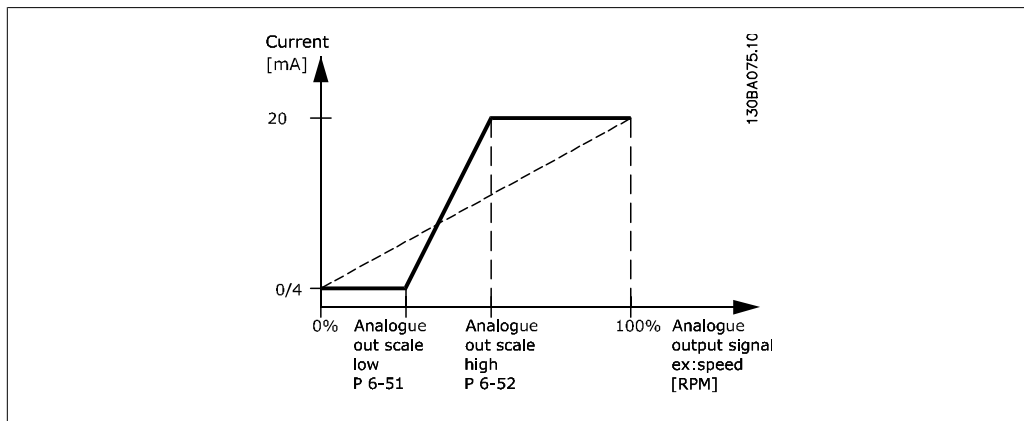

20-12 Reference/Feedback Unit

- Option:**
- [0] None
 - [1] * %
 - [5] PPM
 - [10] 1/min

Function:

[11]	RPM
[12]	Pulse/s
[20]	l/s
[21]	l/min
[22]	l/h
[23]	m ³ /s
[24]	m ³ /min
[25]	m ³ /h
[30]	kg/s
[31]	kg/min
[32]	kg/h
[33]	t/min
[34]	t/h
[40]	m/s
[41]	m/min
[45]	m
[60]	°C
[70]	mbar
[71]	bar
[72]	Pa
[73]	kPa
[74]	m WG
[75]	mm Hg
[80]	kW
[120]	GPM
[121]	gal/s
[122]	gal/min
[123]	gal/h
[124]	CFM
[125]	ft ³ /s
[126]	ft ³ /min
[127]	ft ³ /h
[130]	lb/s
[131]	lb/min
[132]	lb/h
[140]	ft/s
[141]	ft/min
[145]	ft
[160]	°F
[170]	psi
[171]	lb/in ²
[172]	in WG

[173]	ft WG	
[174]	in Hg	
[180]	HP	This parameter determines the unit that is used for the setpoint reference and feedback that the PID controller will use for controlling the output frequency of the adjustable frequency drive.

20-21 Setpoint 1

Range:	Function:
0.000* [Ref _{MIN} par.3-02 - Ref _{MAX} par. 3-03 UNIT (from par. 20-12)]	Setpoint 1 is used in closed-loop mode to enter a setpoint reference that is used by the adjustable frequency drive's PID controller. See the description of <i>Feedback Function</i> , par. 20-20.

NOTE
Setpoint reference entered here is added to any other references that are enabled (see par. group 3-1*).

20-81 PID Normal/Inverse Control

Option:	Function:
[0]* Normal	<p><i>Normal</i> [0] causes the adjustable frequency drive's output frequency to decrease when the feedback is greater than the setpoint reference. This is common for pressure-controlled supply fan and pump applications.</p> <p><i>Inverse</i> [1] causes the adjustable frequency drive's output frequency to increase when the feedback is greater than the setpoint reference.</p>
[1] Inverse	

20-82 PID Start Speed [RPM]

Range:	Function:
0* [0 - 6,000 RPM]	When the adjustable frequency drive is first started, it initially ramps up to this output speed in open-loop mode, following the active ramp-up time. When the output speed programmed here is reached, the adjustable frequency drive will automatically switch to closed-loop mode and the PID controller will begin to function. This is useful in applications in which the driven load must first quickly accelerate to a minimum speed when it is started.



NOTE

This parameter will only be visible if par. 0-02 is set to [0], RPM.

20-93 PID Proportional Gain

Range:

0.50* [0.00 = Off - 10.00]

Function:

This parameter adjusts the output of the adjustable frequency drive's PID controller based on the error between the feedback and the setpoint reference. The quick PID controller response is obtained when this value is large. However, if a value that is too large is used, the adjustable frequency drive's output frequency may become unstable.

20-94 PID Integral Time

Range:

20.00 s* [0.01 - 10,000.00 = Off s]

Function:

Over time, the integrator adds (integrates) the error between the feedback and the setpoint reference. This is required to ensure that the error approaches zero. Quick adjustable frequency drive speed adjustment is obtained when this value is small. However, if a value that is too small is used, the adjustable frequency drive's output frequency may become unstable.

7

7.1.4. Main Menu Mode

Both the GLCP and NLCP provide access to the Main Menu mode. Select Main Menu mode by pressing the [Main Menu] key. Illustration 6.2 shows the resulting read-out, which appears on the display of the GLCP. Lines 2 through 5 on the display show a list of parameter groups which can be chosen by toggling the up and down buttons.

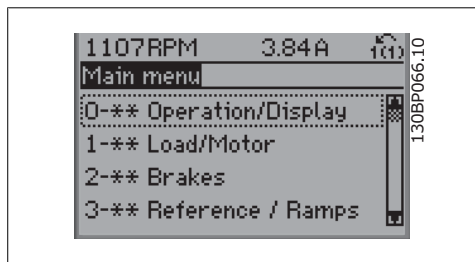

7.9: Display example.

Each parameter has a name and number which remain the same regardless of the programming mode. In Main Menu mode, the parameters are divided into groups. The first digit of the parameter number (from the left) indicates the parameter group number.

All parameters can be changed in the Main Menu. The configuration of the unit (par. 1-00) will determine other parameters available for programming. For example, selecting Closed-loop enables additional parameters related to closed-loop operation. Option cards added to the unit enable additional parameters associated with the option device.

7.1.5. Parameter Selection

In main menu mode, the parameters are divided into groups. Select a parameter group using the navigation keys.

The following parameter groups are accessible:

Group no.	Parameter group:
0	Operation/Display
1	Load/Motor
2	Brakes
3	References/Ramps
4	Limits/Warnings
5	Digital In/Out
6	Analog In/Out
8	Comm. and Options
9	Profibus
10	CAN ser. com. bus
11	LonWorks
13	Smart Logic
14	Special Functions
15	Drive Information
16	Data Readouts
18	Data Readouts 2
20	Drive Closed-loop
21	Ext. Closed-loop
22	Application Functions
23	Time-based Functions
24	Fire Mode
25	Cascade Controller
26	Analog I/O Option MCB 109

7.3: Parameter groups.

After selecting a parameter group, choose a parameter using the navigation keys.

The middle section on the GLCP display shows the parameter number and name, as well as the selected parameter value.

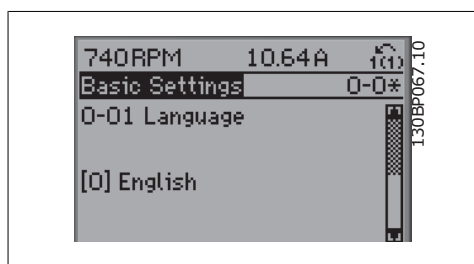

7.10: Display example.

7.1.6. Changing Data

1. Press the [Quick Menu] or [Main Menu] key.
2. Use the [▲] and [▼] keys to find the parameter group to edit.
3. Use the [▲] and [▼] keys to find the parameter to edit.
4. Press the [OK] key.
5. Use the [▲] and [▼] keys to select the correct parameter setting. Or, to move to digits within a number, use the keys. The cursor indicates the selected digit to be changed. The [▲] key increases the value, the [▼] key decreases the value.
6. Press the [Cancel] key to disregard the change, or press the [OK] key to accept the change and enter the new setting.

7.1.7. Changing a Text Value

If the selected parameter is a text value, change the text value using the up/down navigation keys.

The up key increases the value, and the down key decreases the value. Place the cursor on the value to be saved and press [OK].

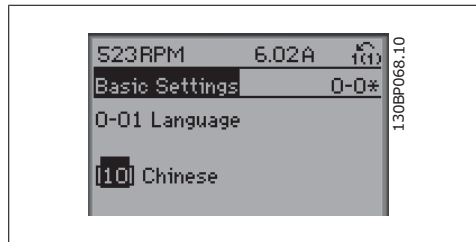

7.11: Display example.

7.1.8. Changing a Group of Numeric Data Values

If the chosen parameter represents a numeric data value, change the chosen data value using the <> navigation keys as well as the up/down navigation keys. Use the <> navigation keys to move the cursor horizontally.

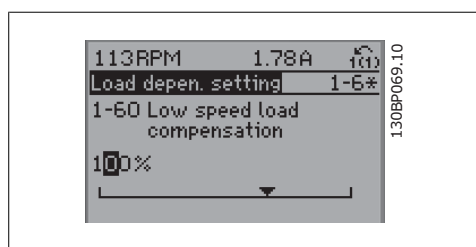

7.12: Display example.

Use the up/down navigation keys to change the data value. The up key increases the data value, and the down key reduces the data value. Place the cursor on the value to be saved and press [OK].

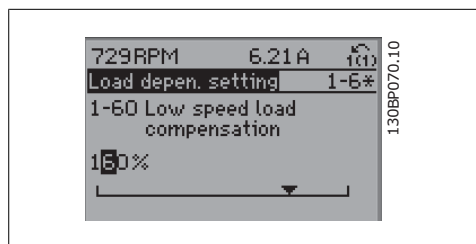

7.13: Display example.

7.1.9. Changing Data Value, Step-by-Step

Certain parameters can be changed step-by-step or by an infinite number of variables. This applies to *Motor Power* (par. 1-20), *Motor Voltage* (par. 1-22) and *Motor Frequency* (par. 1-23).

The parameters are changed both as a group of numeric data values and as numeric data values using an infinite number of variables.

7.1.10. Read-out and Programming of Indexed Parameters

Parameters are indexed when placed in a rolling stack.

Par. 15-30 to 15-32 contain a fault log that can be read out. Choose a parameter, press [OK], and use the up/down navigation keys to scroll through the value log.

Use par. 3-10 as another example:

Choose the parameter, press [OK], and use the up/down navigation keys to scroll through the indexed values. To change the parameter value, select the indexed value and press [OK]. Change

the value by using the up/down keys. Press [OK] to accept the new setting. Press [Cancel] to abort. Press [Back] to leave the parameter.

20-81 PID Normal/Inverse Control	
Option:	Function:
[0] * Normal	
[1] Inverse	<p><i>Normal</i> [0] causes the adjustable frequency drive's output frequency to decrease when the feedback is greater than the setpoint reference. This is common for pressure-controlled supply fan and pump applications.</p> <p><i>Inverse</i> [1] causes the adjustable frequency drive's output frequency to increase when the feedback is greater than the setpoint reference. This is common for temperature-controlled cooling applications, such as cooling towers.</p>

7.1.11. Initialization to Default Settings

Initialize the adjustable frequency drive using default settings in two ways:

Recommended initialization (via par. 14-22)

1. Select par. 14-22
2. Press [OK]
3. Select "Initialization"
4. Press [OK]
5. Cut off the line power supply and wait until the display turns off.
6. Reconnect the line power supply - the adjustable frequency drive is now reset.
7. Change par. 14-22 back to *Normal Operation*.

NOTE
Keeps parameters selected in *Personal Menu* with default factory setting.

Par. 14-22 initializes everything except:	
14-50	<i>RFI 1</i>
8-30	<i>Protocol</i>
8-31	<i>Address</i>
8-32	<i>Baud Rate</i>
8-35	<i>Minimum Response Delay</i>
8-36	<i>Max Response Delay</i>
8-37	<i>Max Inter-char Delay</i>
15-00 to 15-05	Operating data
15-20 to 15-22	Historical log
15-30 to 15-32	Fault log

Manual initialization

1. Disconnect from the power supply and wait until the display turns off.
- 2a. Press [Status] - [Main Menu] - [OK] at the same time the LCP 102, Graphical Display is powering up.
- 2b. Press [Menu] while the LCP 101, Numerical Display is powering up.
3. Release the keys after 5 s.
4. The adjustable frequency drive is now programmed according to default settings.

This procedure initializes all except:

15-00	Operating Hours
15-03	Power-ups
15-04	Overtmps
15-05	Overvolts

 **NOTE**
 When you carry out manual initialization, you also reset serial communication, RFI filter settings (par. 14-50) and fault log settings.
 Removes parameters selected in *Personal Menu*.

 **NOTE**
 After initialization and power cycling, the display will not show any information until after a couple of minutes.

7

7.2. Parameter Options

7.2.1. Default settings

Changes during operation

"TRUE" means that the parameter can be changed while the adjustable frequency drive is in operation, and "FALSE" means that the adjustable frequency drive must be stopped before a change can be made.

4-Set-up

'All set-up': the parameter can be set individually in each of the four set-ups, i.e., one single parameter can have four different data values.

'1 set-up': the data value will be the same in all set-ups.

Conversion index

This number refers to a conversion figure used when writing or reading by means of an adjustable frequency drive.

Conv. index	100	67	6	5	4	3	2	1	0	-1	-2	-3	-4	-5	-6
Conv. factor	1	1/60	100000 0	100000	10000	1000	100	10	1	0.1	0.01	0.00	0.000	0.0000	0.000001

Data type	Description	Type
2	Integer 8	Int8
3	Integer 16	Int16
4	Integer 32	Int32
5	Unsigned 8	UInt8
6	Unsigned 16	UInt16
7	Unsigned 32	UInt32
9	Visible String	VisStr
33	Normalized value 2 bytes	N2
35	Bit sequence of 16 Boolean variables	V2
54	Time difference w/o date	TimD

SR = Size related

7.2.2. 0- ** Operation/Display

Par. No. #	Parameter description	Default value	4 set-up	Change during operation	Conversion index	Type
0-0* Basic Settings						
0-01	Language	[0] English	1 set-up	TRUE	-	UInt8
0-02	Motor Speed Unit	[0] RPM	2 set-ups	FALSE	-	UInt8
0-03	Regional Settings	[0] International	2 set-ups	FALSE	-	UInt8
0-04	Operating State at Power-up	[0] Resume	All set-ups	TRUE	-	UInt8
0-05	Local Mode Unit	[0] As Motor Speed Unit	2 set-ups	FALSE	-	UInt8
0-1* Set-up Operations						
0-10	Active Set-up	[1] Set-up 1	1 set-up	TRUE	-	UInt8
0-11	Programming Set-up	[9] Active Set-up	All set-ups	TRUE	-	UInt8
0-12	This Set-up Linked to	[0] Not linked	All set-ups	FALSE	-	UInt8
0-13	Readout: Linked Set-ups	0 N/A	All set-ups	FALSE	0	UInt16
0-14	Readout: Prog. Set-ups/Channel	0 N/A	All set-ups	TRUE	0	Int32
0-2* LCP Display						
0-20	Display Line 1.1 Small	1601	All set-ups	TRUE	-	UInt16
0-21	Display Line 1.2 Small	1662	All set-ups	TRUE	-	UInt16
0-22	Display Line 1.3 Small	1614	All set-ups	TRUE	-	UInt16
0-23	Display Line 2 Large	1613	All set-ups	TRUE	-	UInt16
0-24	Display Line 3 Large	1652	All set-ups	TRUE	-	UInt16
0-25	My Personal Menu	SR	1 set-up	TRUE	0	UInt16
0-3* LCP Custom Readout						
0-30	Custom Readout Unit	[1] %	All set-ups	TRUE	-	UInt8
0-31	Custom Readout Min Value	SR	All set-ups	TRUE	-2	Int32
0-32	Custom Readout Max Value	100.00 CustomReadoutUnit	All set-ups	TRUE	-2	Int32
0-37	Display Text 1	0 N/A	1 set-up	TRUE	0	VisStr[25]
0-38	Display Text 2	0 N/A	1 set-up	TRUE	0	VisStr[25]
0-39	Display Text 3	0 N/A	1 set-up	TRUE	0	VisStr[25]
0-4* LCP Keypad						
0-40	[Hand on] Key on LCP	[1] Enabled	All set-ups	TRUE	-	UInt8
0-41	[Off] Key on LCP	[1] Enabled	All set-ups	TRUE	-	UInt8
0-42	[Auto on] Key on LCP	[1] Enabled	All set-ups	TRUE	-	UInt8
0-43	[Reset] Key on LCP	[1] Enabled	All set-ups	TRUE	-	UInt8
0-44	[Off/Reset] Key on LCP	[1] Enabled	All set-ups	TRUE	-	UInt8
0-45	[Drive Bypass] Key on LCP	[1] Enabled	All set-ups	TRUE	-	UInt8
0-5* Copy/Save						
0-50	LCP Copy	[0] No copy	All set-ups	FALSE	-	UInt8
0-51	Set-up Copy	[0] No copy	All set-ups	FALSE	-	UInt8
0-6* Password						
0-60	Main Menu Password	100 N/A	1 set-up	TRUE	0	UInt16
0-61	Access to Main Menu w/o Password	[0] Full access	1 set-up	TRUE	-	UInt8
0-65	Personal Menu Password	200 N/A	1 set-up	TRUE	0	UInt16
0-66	Access to Personal Menu w/o Password	[0] Full access	1 set-up	TRUE	-	UInt8

Par. No. #	Parameter description	Default value	4 set-up	Change during operation	Conversion index	Type
0-7* Clock Settings						
0-70	Set Date and Time	SR	1 set-up	TRUE	0	TimeOfDay
0-71	Date Format	[0] YYYY-MM-DD	1 set-up	TRUE	-	UInt8
0-72	Time Format	[0] 24h	1 set-up	TRUE	-	UInt8
0-74	DST/Summertime	[0] Off	1 set-up	TRUE	-	UInt8
0-76	DST/Summertime Start	SR	1 set-up	TRUE	0	TimeOfDay
0-77	DST/Summertime End	SR	1 set-up	TRUE	0	TimeOfDay
0-79	Clock Fault	null	1 set-up	TRUE	-	UInt8
0-81	Working Days	null	1 set-up	TRUE	-	UInt8
0-82	Additional Working Days	SR	1 set-up	TRUE	0	TimeOfDay
0-83	Additional Non-Working Days	SR	1 set-up	TRUE	0	TimeOfDay
0-89	Date and Time Readout	0 N/A	All set-ups	TRUE	0	VisStr[25]

7.2.3. 1- ** Load/Motor

Par. No. #	Parameter description	Default value	4 set-up	Change during operation	Conversion index	Type
1-0* General Settings						
1-00	Configuration Mode	null	All set-ups	TRUE	-	Uint8
1-03	Torque Characteristics	[3] Auto Energy Optim. VT	All set-ups	TRUE	-	Uint8
1-2* Motor Data						
1-20	Motor Power [kW]	SR	All set-ups	FALSE	1	Uint32
1-21	Motor Power [HP]	SR	All set-ups	FALSE	-2	Uint32
1-22	Motor Voltage	SR	All set-ups	FALSE	0	Uint16
1-23	Motor Frequency	SR	All set-ups	FALSE	0	Uint16
1-24	Motor Current	SR	All set-ups	FALSE	-2	Uint32
1-25	Motor Nominal Speed	SR	All set-ups	FALSE	67	Uint16
1-28	Motor Rotation Check	[0] Off	All set-ups	FALSE	-	Uint8
1-29	Automatic Motor Adaptation (AMA)	[0] Off	All set-ups	FALSE	-	Uint8
1-3* Adv. Motor Data						
1-30	Stator Resistance (Rs)	SR	All set-ups	FALSE	-4	Uint32
1-31	Rotor Resistance (Rr)	SR	All set-ups	FALSE	-4	Uint32
1-35	Main Reactance (Xh)	SR	All set-ups	FALSE	-4	Uint32
1-36	Iron Loss Resistance (Rfe)	SR	All set-ups	FALSE	-3	Uint32
1-39	Motor Poles	SR	All set-ups	FALSE	0	Uint8
1-5* Load Indep. Setting						
1-50	Motor Magnetization at Zero Speed	100 %	All set-ups	TRUE	0	Uint16
1-51	Min Speed Normal Magnetizing [RPM]	SR	All set-ups	TRUE	67	Uint16
1-52	Min Speed Normal Magnetizing [Hz]	SR	All set-ups	TRUE	-1	Uint16
1-6* Load Depen. Setting						
1-60	Low Speed Load Compensation	100 %	All set-ups	TRUE	0	Int16
1-61	High Speed Load Compensation	100 %	All set-ups	TRUE	0	Int16
1-62	Slip Compensation	0 %	All set-ups	TRUE	0	Int16
1-63	Slip Compensation Time Constant	0.10 s	All set-ups	TRUE	-2	Uint16
1-64	Resonance Damping	100 %	All set-ups	TRUE	0	Uint16
1-65	Resonance Damping Time Constant	5 ms	All set-ups	TRUE	-3	Uint8
1-7* Start Adjustments						
1-71	Start Delay	0.0 s	All set-ups	TRUE	-1	Uint16
1-73	Flying Start	[0] Disabled	All set-ups	FALSE	-	Uint8
1-8* Stop Adjustments						
1-80	Function at Stop	[0] Coast	All set-ups	TRUE	-	Uint8
1-81	Min Speed for Function at Stop [RPM]	SR	All set-ups	TRUE	67	Uint16
1-82	Min. Speed for Function at Stop [Hz]	SR	All set-ups	TRUE	-1	Uint16
1-9* Motor Temperature						
1-90	Motor Thermal Protection	[4] ETR trip 1	All set-ups	TRUE	-	Uint8
1-91	Motor External Fan	[0] No	All set-ups	TRUE	-	Uint16
1-93	Thermistor Source	[0] None	All set-ups	TRUE	-	Uint8

7.2.4. 2-* * Brakes

Par. No. #	Parameter description	Default value	4 set-up	Change during operation	Conversion index	Type
2-0* DC Brake						
2-00	DC Hold/Preheat Current	50 %	All set-ups	TRUE	0	Uint8
2-01	DC Brake Current	50 %	All set-ups	TRUE	0	Uint16
2-02	DC Braking Time	10.0 s	All set-ups	TRUE	-1	Uint16
2-03	DC Brake Cut-in Speed [RPM]	SR	All set-ups	TRUE	67	Uint16
2-04	DC Brake Cut-in Speed [Hz]	SR	All set-ups	TRUE	-1	Uint16
2-1* Brake Energy Funct.						
2-10	Brake Function	[0] Off	All set-ups	TRUE	-	Uint8
2-11	Brake Resistor (ohm)	SR	All set-ups	TRUE	0	Uint16
2-12	Braking Energy Limit (kW)	SR	All set-ups	TRUE	0	Uint32
2-13	Braking Energy Monitoring	[0] Off	All set-ups	TRUE	-	Uint8
2-15	Brake Check	[0] Off	All set-ups	TRUE	-	Uint8
2-16	AC Brake Max. Current	100.0 %	All set-ups	TRUE	-1	Uint32
2-17	Overvoltage Control	[2] Enabled	All set-ups	TRUE	-	Uint8

7.2.5. 3- ** Reference / Ramps

Par. No. #	Parameter description	Default value	4 set-up	Change during operation	Conversion index	Type
3-0* Reference Limits						
3-02	Minimum Reference	SR	All set-ups	TRUE	-3	Int32
3-03	Maximum Reference	SR	All set-ups	TRUE	-3	Int32
3-04	Reference Function	[0] Sum	All set-ups	TRUE	-	UInt8
3-1* References						
3-10	Preset Reference	0.00 %	All set-ups	TRUE	-2	Int16
3-11	Jog Speed [Hz]	SR	All set-ups	TRUE	-1	UInt16
3-13	Reference Site	[0] Linked to Hand / Auto	All set-ups	TRUE	-	UInt8
3-14	Preset Relative Reference	0.00 %	All set-ups	TRUE	-2	Int32
3-15	Reference 1 Source	[1] Analog input 53	All set-ups	TRUE	-	UInt8
3-16	Reference 2 Source	[0] No function	All set-ups	TRUE	-	UInt8
3-17	Reference 3 Source	[0] No function	All set-ups	TRUE	-	UInt8
3-19	Jog Speed [RPM]	SR	All set-ups	TRUE	67	UInt16
3-4* Ramp 1						
3-41	Ramp 1 Ramp-up Time	SR	All set-ups	TRUE	-2	UInt32
3-42	Ramp 1 Ramp-down Time	SR	All set-ups	TRUE	-2	UInt32
3-5* Ramp 2						
3-51	Ramp 2 Ramp-up Time	SR	All set-ups	TRUE	-2	UInt32
3-52	Ramp 2 Ramp-down Time	SR	All set-ups	TRUE	-2	UInt32
3-8* Other Ramps						
3-80	Jog Ramp Time	SR	All set-ups	TRUE	-2	UInt32
3-81	Quick Stop Ramp Time	SR	2 set-ups	TRUE	-2	UInt32
3-84	Initial Ramp Time	0(Off)	All set-ups	TRUE	-	-
3-85	Check Valve Ramp Time	0(Off)	All set-ups	TRUE	-	-
3-86	Check Valve Ramp End Speed [RPM]	Motor Speed Low Limit	All set-ups	TRUE	-	-
3-87	Check Valve Ramp End Speed [Hz]	Motor Speed Low Limit	All set-ups	TRUE	-	-
3-88	Final Ramp Time	0(Off)	All set-ups	TRUE	-	-
3-9* Digital Pot.Meter						
3-90	Step Size	0.10 %	All set-ups	TRUE	-2	UInt16
3-91	Ramp Time	1.00 s	All set-ups	TRUE	-2	UInt32
3-92	Power Restore	[0] Off	All set-ups	TRUE	-	UInt8
3-93	Maximum Limit	100 %	All set-ups	TRUE	0	Int16
3-94	Minimum Limit	0 %	All set-ups	TRUE	0	Int16
3-95	Ramp Delay	1.000 N/A	All set-ups	TRUE	-3	TimD

7.2.6. 4- * * Limits / Warnings

Par. No. #	Parameter description	Default value	4 set-up	Change during operation	Conversion index	Type
4-1 * Motor Limits						
4-10	Motor Speed Direction	[0] Clockwise	All set-ups	FALSE	-	UInt8
4-11	Motor Speed Low Limit [RPM]	SR	All set-ups	TRUE	67	UInt16
4-12	Motor Speed Low Limit [Hz]	SR	All set-ups	TRUE	-1	UInt16
4-13	Motor Speed High Limit [RPM]	SR	All set-ups	TRUE	67	UInt16
4-14	Motor Speed High Limit [Hz]	SR	All set-ups	TRUE	-1	UInt16
4-16	Torque Limit Motor Mode	110.0 %	All set-ups	TRUE	-1	UInt16
4-17	Torque Limit Generator Mode	100.0 %	All set-ups	TRUE	-1	UInt16
4-18	Current Limit	SR	All set-ups	TRUE	-1	UInt32
4-19	Max Output Frequency	120 Hz	All set-ups	FALSE	-1	UInt16
4-5 * Adj. Warnings						
4-50	Warning Current Low	0.00 A	All set-ups	TRUE	-2	UInt32
4-51	Warning Current High	I _{max} VLT (P1637)	All set-ups	TRUE	-2	UInt32
4-52	Warning Speed Low	0 RPM	All set-ups	TRUE	67	UInt16
4-53	Warning Speed High	outputSpeedHighLimit (P413)	All set-ups	TRUE	67	UInt16
4-54	Warning Reference Low	-999999,999 N/A	All set-ups	TRUE	-3	Int32
4-55	Warning Reference High	999999,999 N/A	All set-ups	TRUE	-3	Int32
4-56	Warning Feedback Low	-999999,999 ReferenceFeedbackUnit	All set-ups	TRUE	-3	Int32
4-57	Warning Feedback High	999999,999 ReferenceFeedbackUnit	All set-ups	TRUE	-3	Int32
4-58	Missing Motor Phase Function	[1] On	All set-ups	TRUE	-	UInt8
4-6 * Speed Bypass						
4-60	Bypass Speed From [RPM]	SR	All set-ups	TRUE	67	UInt16
4-61	Bypass Speed From [Hz]	SR	All set-ups	TRUE	-1	UInt16
4-62	Bypass Speed To [RPM]	SR	All set-ups	TRUE	67	UInt16
4-63	Bypass Speed To [Hz]	SR	All set-ups	TRUE	-1	UInt16
4-64	Semi-Auto Bypass Set-up	[0] Off	All set-ups	FALSE	-	UInt8

7.2.7. 5- ** Digital In/Out

Par. No. #	Parameter description	Default value	4 set-up	Change during operation	Conversion index	Type
5-0* Digital I/O mode						
5-00	Digital I/O Mode	[0] PNP - Active at 24 V	All set-ups	FALSE	-	Uint8
5-01	Terminal 27 Mode	[0] Input	All set-ups	TRUE	-	Uint8
5-02	Terminal 29 Mode	[0] Input	All set-ups	TRUE	-	Uint8
5-1* Digital Inputs						
5-10	Terminal 18 Digital Input	[8] Start	All set-ups	TRUE	-	Uint8
5-11	Terminal 19 Digital Input	[0] No operation	All set-ups	TRUE	-	Uint8
5-12	Terminal 27 Digital Input	[0] No operation	All set-ups	TRUE	-	Uint8
5-13	Terminal 29 Digital Input	[0] No operation	All set-ups	TRUE	-	Uint8
5-14	Terminal 32 Digital Input	[0] No operation	All set-ups	TRUE	-	Uint8
5-15	Terminal 33 Digital Input	[0] No operation	All set-ups	TRUE	-	Uint8
5-16	Terminal X30/2 Digital Input	[0] No operation	All set-ups	TRUE	-	Uint8
5-17	Terminal X30/3 Digital Input	[0] No operation	All set-ups	TRUE	-	Uint8
5-18	Terminal X30/4 Digital Input	[0] No operation	All set-ups	TRUE	-	Uint8
5-3* Digital Outputs						
5-30	Terminal 27 Digital Output	[0] No operation	All set-ups	TRUE	-	Uint8
5-31	Terminal 29 Digital Output	[0] No operation	All set-ups	TRUE	-	Uint8
5-32	Term X30/6 Digi Out (MCB 101)	[0] No operation	All set-ups	TRUE	-	Uint8
5-33	Term X30/7 Digi Out (MCB 101)	[0] No operation	All set-ups	TRUE	-	Uint8
5-4* Relays						
5-40	Function Relay	[0] No operation	All set-ups	TRUE	-	Uint8
5-41	On Delay, Relay	0.01 s	All set-ups	TRUE	-2	Uimt16
5-42	Off Delay, Relay	0.01 s	All set-ups	TRUE	-2	Uimt16
5-5* Pulse Input						
5-50	Term. 29 Low Frequency	100 Hz	All set-ups	TRUE	0	Uimt32
5-51	Term. 29 High Frequency	100 Hz	All set-ups	TRUE	0	Uimt32
5-52	Term. 29 Low Ref./Feedb. Value	0.000 N/A	All set-ups	TRUE	-3	Int32
5-53	Term. 29 High Ref./Feedb. Value	100.000 N/A	All set-ups	TRUE	-3	Int32
5-54	Pulse Filter Time Constant #29	100 ms	All set-ups	FALSE	-3	Uimt16
5-55	Term. 33 Low Frequency	100 Hz	All set-ups	TRUE	0	Uimt32
5-56	Term. 33 High Frequency	100 Hz	All set-ups	TRUE	0	Uimt32
5-57	Term. 33 Low Ref./Feedb. Value	0.000 N/A	All set-ups	TRUE	-3	Int32
5-58	Term. 33 High Ref./Feedb. Value	100.000 N/A	All set-ups	TRUE	-3	Int32
5-59	Pulse Filter Time Constant #33	100 ms	All set-ups	FALSE	-3	Uimt16
5-6* Pulse Output						
5-60	Terminal 27 Pulse Output Variable	[0] No operation	All set-ups	TRUE	-	Uint8
5-62	Pulse Output Max Freq #27	5000 Hz	All set-ups	TRUE	0	Uimt32
5-63	Terminal 29 Pulse Output Variable	[0] No operation	All set-ups	TRUE	-	Uint8
5-65	Pulse Output Max Freq #29	5000 Hz	All set-ups	TRUE	0	Uimt32
5-66	Terminal X30/6 Pulse Output Variable	[0] No operation	All set-ups	TRUE	-	Uint8
5-68	Pulse Output Max Freq #X30/6	5000 Hz	All set-ups	TRUE	0	Uimt32

Par. No. #	Parameter description	Default value	4 set-up	Change during operation	Conversion index	Type
5-9* Bus Controlled						
5-90	Digital & Relay Bus Control	0 N/A	All set-ups	TRUE	0	Ujnt32
5-93	Pulse Out #27 Bus Control	0.00 %	All set-ups	TRUE	-2	N2
5-94	Pulse Out #27 Timeout Preset	0.00 %	1 set-up	TRUE	-2	Ujnt16
5-95	Pulse Out #29 Bus Control	0.00 %	All set-ups	TRUE	-2	N2
5-96	Pulse Out #29 Timeout Preset	0.00 %	1 set-up	TRUE	-2	Ujnt16
5-97	Pulse Out #X30/6 Bus Control	0.00 %	All set-ups	TRUE	-2	N2
5-98	Pulse Out #X30/6 Timeout Preset	0.00 %	1 set-up	TRUE	-2	Ujnt16

7.2.8. 6- ** Analog In/Out

Par. No. #	Parameter description	Default value	4 set-up	Change during operation	Conversion index	Type
6-0* Analog I/O Mode						
6-00	Live Zero Timeout Time	10 s	All set-ups	TRUE	0	Uint8
6-01	Live Zero Timeout Function	[0] Off	All set-ups	TRUE	-	Uint8
6-02	Fire Mode Live Zero Timeout Function	null	All set-ups	TRUE	-	Uint8
6-1* Analog Input 53						
6-10	Terminal 53 Low Voltage	0.07 V	All set-ups	TRUE	-2	Int16
6-11	Terminal 53 High Voltage	10.00 V	All set-ups	TRUE	-2	Int16
6-12	Terminal 53 Low Current	4.00 mA	All set-ups	TRUE	-5	Int16
6-13	Terminal 53 High Current	20.00 mA	All set-ups	TRUE	-5	Int16
6-14	Terminal 53 Low Ref./Feedb. Value	0.000 N/A	All set-ups	TRUE	-3	Int32
6-15	Terminal 53 High Ref./Feedb. Value	SR	All set-ups	TRUE	-3	Int32
6-16	Terminal 53 Filter Time Constant	0.001 s	All set-ups	TRUE	-3	Uint16
6-17	Terminal 53 Live Zero	[1] Enabled	All set-ups	TRUE	-	Uint8
6-2* Analog Input 54						
6-20	Terminal 54 Low Voltage	0.07 V	All set-ups	TRUE	-2	Int16
6-21	Terminal 54 High Voltage	10.00 V	All set-ups	TRUE	-2	Int16
6-22	Terminal 54 Low Current	4.00 mA	All set-ups	TRUE	-5	Int16
6-23	Terminal 54 High Current	20.00 mA	All set-ups	TRUE	-5	Int16
6-24	Terminal 54 Low Ref./Feedb. Value	0.000 N/A	All set-ups	TRUE	-3	Int32
6-25	Terminal 54 High Ref./Feedb. Value	100.000 N/A	All set-ups	TRUE	-3	Int32
6-26	Terminal 54 Filter Time Constant	0.001 s	All set-ups	TRUE	-3	Uint16
6-27	Terminal 54 Live Zero	[1] Enabled	All set-ups	TRUE	-	Uint8
6-3* Analog Input X30/11						
6-30	Terminal X30/11 Low Voltage	0.07 V	All set-ups	TRUE	-2	Int16
6-31	Terminal X30/11 High Voltage	10.00 V	All set-ups	TRUE	-2	Int16
6-34	Term. X30/11 Low Ref./Feedb. Value	0.000 N/A	All set-ups	TRUE	-3	Int32
6-35	Term. X30/11 High Ref./Feedb. Value	100.000 N/A	All set-ups	TRUE	-3	Int32
6-36	Term. X30/11 Filter Time Constant	0.001 s	All set-ups	TRUE	-3	Uint16
6-37	Term. X30/11 Live Zero	[1] Enabled	All set-ups	TRUE	-	Uint8
6-4* Analog Input X30/12						
6-40	Terminal X30/12 Low Voltage	0.07 V	All set-ups	TRUE	-2	Int16
6-41	Terminal X30/12 High Voltage	10.00 V	All set-ups	TRUE	-2	Int16
6-44	Term. X30/12 Low Ref./Feedb. Value	0.000 N/A	All set-ups	TRUE	-3	Int32
6-45	Term. X30/12 High Ref./Feedb. Value	100.000 N/A	All set-ups	TRUE	-3	Int32
6-46	Term. X30/12 Filter Time Constant	0.001 s	All set-ups	TRUE	-3	Uint16
6-47	Term. X30/12 Live Zero	[1] Enabled	All set-ups	TRUE	-	Uint8
6-5* Analog Output 42						
6-50	Terminal 42 Output	[100] Output frequency	All set-ups	TRUE	-	Uint8
6-51	Terminal 42 Output Min Scale	0.00 %	All set-ups	TRUE	-2	Int16
6-52	Terminal 42 Output Max Scale	100.00 %	All set-ups	TRUE	-2	Int16
6-53	Terminal 42 Output Bus Control	0.00 %	All set-ups	TRUE	-2	N2
6-54	Terminal 42 Output Timeout Preset	0.00 %	1 set-up	TRUE	-2	Uint16

Par. No. #	Parameter description	Default value	4 set-up	Change during operation	Conversion index	Type
6-6* Analog Output X30/8						
6-60	Terminal X30/8 Output	[0] No operation	All set-ups	TRUE	-	Uint8
6-61	Terminal X30/8 Min. Scale	0.00 %	All set-ups	TRUE	-2	Int16
6-62	Terminal X30/8 Max. Scale	100.00 %	All set-ups	TRUE	-2	Int16
6-63	Terminal X30/8 Output Bus Control	0.00 %	All set-ups	TRUE	-2	N2
6-64	Terminal X30/8 Output Timeout Preset	0.00 %	1 set-up	TRUE	-2	Uint16

7.2.9. 8- * Comm. and Options

Par. No. #	Parameter description	Default value	4 set-up	Change during operation	Conversion index	Type
8-0* General Settings						
8-01	Control Site	[0] Digital and ctrl.word	All set-ups	TRUE	-	Uint8
8-02	Control Source	[0] None	All set-ups	TRUE	-	Uint8
8-03	Control Timeout Time	SR	1 set-up	TRUE	-1	Uint32
8-04	Control Timeout Function	[0] Off	1 set-up	TRUE	-	Uint8
8-05	End-of-Timeout Function	[1] Resume set-up	1 set-up	TRUE	-	Uint8
8-06	Reset Control Timeout	[0] Do not reset	All set-ups	TRUE	-	Uint8
8-07	Diagnosis Trigger	[0] Disable	2 set-ups	TRUE	-	Uint8
8-1* Control Settings						
8-10	Control Profile	[0] FC profile	All set-ups	TRUE	-	Uint8
8-13	Configurable Status Word STW	[1] Profile Default	All set-ups	TRUE	-	Uint8
8-3* FC Port Settings						
8-30	Protocol	[0] FC	1 set-up	TRUE	-	Uint8
8-31	Address	1 N/A	1 set-up	TRUE	0	Uint8
8-32	Baud Rate	null	1 set-up	TRUE	-	Uint8
8-33	Parity / Stop Bits	null	1 set-up	TRUE	-	Uint8
8-35	Minimum Response Delay	10 ms	1 set-up	TRUE	-3	Uint16
8-36	Max Response Delay	SR	1 set-up	TRUE	-3	Uint16
8-37	Max Inter-Char Delay	SR	1 set-up	TRUE	-5	Uint16
8-4* FC MC protocol set						
8-40	Telegram Selection	[1] Standard telegram 1	2 set-ups	TRUE	-	Uint8
8-5* Digital/Bus						
8-50	Coasting Select	[3] Logic OR	All set-ups	TRUE	-	Uint8
8-52	DC Brake Select	[3] Logic OR	All set-ups	TRUE	-	Uint8
8-53	Start Select	[3] Logic OR	All set-ups	TRUE	-	Uint8
8-54	Reversing Select	[0] Digital input	All set-ups	TRUE	-	Uint8
8-55	Set-up Select	[3] Logic OR	All set-ups	TRUE	-	Uint8
8-56	Preset Reference Select	[3] Logic OR	All set-ups	TRUE	-	Uint8
8-7* BACnet						
8-70	BACnet Device Instance	1 N/A	1 set-up	TRUE	0	Uint32
8-72	MS/TP Max Masters	127 N/A	1 set-up	TRUE	0	Uint8
8-73	MS/TP Max Info Frames	1 N/A	1 set-up	TRUE	0	Uint16
8-74	"I-Am" Service	[0] Send at power-up	1 set-up	TRUE	-	Uint8
8-75	Initialization Password	0 N/A	1 set-up	TRUE	0	VisStr[20]
8-8* FC Port Diagnostics						
8-80	Bus Message Count	0 N/A	All set-ups	TRUE	0	Uint32
8-81	Bus Error Count	0 N/A	All set-ups	TRUE	0	Uint32
8-82	Slave Message Count	0 N/A	All set-ups	TRUE	0	Uint32
8-83	Slave Error Count	0 N/A	All set-ups	TRUE	0	Uint32
8-9* Bus Jog / Feedback						
8-90	Bus Jog 1 Speed	100 RPM	All set-ups	TRUE	67	Uint16
8-91	Bus Jog 2 Speed	200 RPM	All set-ups	TRUE	67	Uint16
8-94	Bus Feedback 1	0 N/A	1 set-up	TRUE	0	N2
8-95	Bus Feedback 2	0 N/A	1 set-up	TRUE	0	N2
8-96	Bus Feedback 3	0 N/A	1 set-up	TRUE	0	N2

7.2.10. 9- ** Profibus

Par. No. #	Parameter description	Default value	4 set-up	Change during operation	Conversion index	Type
9-00	Setpoint	0 N/A	All set-ups	TRUE	0	Uint16
9-07	Actual Value	0 N/A	All set-ups	FALSE	0	Uint16
9-15	PCD Write Configuration	SR	2 set-ups	TRUE	-	Uint16
9-16	PCD Read Configuration	SR	2 set-ups	TRUE	-	Uint16
9-18	Node Address	126 N/A	1 set-up	TRUE	0	Uint8
9-22	Telegram Selection	[108] PPO 8	1 set-up	TRUE	-	Uint8
9-23	Parameters for Signals	0	All set-ups	TRUE	-	Uint16
9-27	Parameter Edit	[1] Enabled	2 set-ups	FALSE	-	Uint16
9-28	Process Control	[1] Enable cyclic master	2 set-ups	FALSE	-	Uint8
9-44	Fault Message Counter	0 N/A	All set-ups	TRUE	0	Uint16
9-45	Fault Code	0 N/A	All set-ups	TRUE	0	Uint16
9-47	Fault Number	0 N/A	All set-ups	TRUE	0	Uint16
9-52	Fault Situation Counter	0 N/A	All set-ups	TRUE	0	Uint16
9-53	Profibus Warning Word	0 N/A	All set-ups	TRUE	0	Uint16
9-63	Actual Baud Rate	0 N/A	All set-ups	TRUE	0	V2
9-64	Device Identification	[255] No baud rate found	All set-ups	TRUE	-	Uint8
9-65	Profile Number	0 N/A	All set-ups	TRUE	0	Uint16
9-67	Control Word 1	0 N/A	All set-ups	TRUE	0	OctStr[2] V2
9-68	Status Word 1	0 N/A	All set-ups	TRUE	0	V2
9-71	Profibus Save Data Values	[0] Off	All set-ups	TRUE	-	Uint8
9-72	ProfibusDriveReset	[0] No action	1 set-up	FALSE	-	Uint8
9-80	Defined Parameters (1)	0 N/A	All set-ups	FALSE	0	Uint16
9-81	Defined Parameters (2)	0 N/A	All set-ups	FALSE	0	Uint16
9-82	Defined Parameters (3)	0 N/A	All set-ups	FALSE	0	Uint16
9-83	Defined Parameters (4)	0 N/A	All set-ups	FALSE	0	Uint16
9-84	Defined Parameters (5)	0 N/A	All set-ups	FALSE	0	Uint16
9-90	Changed Parameters (1)	0 N/A	All set-ups	FALSE	0	Uint16
9-91	Changed Parameters (2)	0 N/A	All set-ups	FALSE	0	Uint16
9-92	Changed Parameters (3)	0 N/A	All set-ups	FALSE	0	Uint16
9-93	Changed Parameters (4)	0 N/A	All set-ups	FALSE	0	Uint16
9-94	Changed Parameters (5)	0 N/A	All set-ups	FALSE	0	Uint16

7.2.11. 10-* *CAN Ser. Com. Bus

Par. No. #	Parameter description	Default value	4 set-up	Change during operation	Conversion index	Type
10-0* Common Settings						
10-00	CAN Protocol	null	2 set-ups	FALSE	-	Uint8
10-01	Baud Rate Select	null	2 set-ups	TRUE	-	Uint8
10-02	MAC ID	SR	2 set-ups	TRUE	0	Uint8
10-05	Readout Transmit Error Counter	0 N/A	All set-ups	TRUE	0	Uint8
10-06	Readout Receive Error Counter	0 N/A	All set-ups	TRUE	0	Uint8
10-07	Readout Bus Off Counter	0 N/A	All set-ups	TRUE	0	Uint8
10-1* DeviceNet						
10-10	Process Data Type Selection	null	All set-ups	TRUE	-	Uint8
10-11	Process Data Config Write	SR	2 set-ups	TRUE	-	Uint16
10-12	Process Data Config Read	SR	2 set-ups	TRUE	-	Uint16
10-13	Warning Parameter	0 N/A	All set-ups	TRUE	0	Uint16
10-14	Net Reference	[0] Off	2 set-ups	TRUE	-	Uint8
10-15	Net Control	[0] Off	2 set-ups	TRUE	-	Uint8
10-2* COS Filters						
10-20	COS Filter 1	0 N/A	All set-ups	FALSE	0	Uint16
10-21	COS Filter 2	0 N/A	All set-ups	FALSE	0	Uint16
10-22	COS Filter 3	0 N/A	All set-ups	FALSE	0	Uint16
10-23	COS Filter 4	0 N/A	All set-ups	FALSE	0	Uint16
10-3* Parameter Access						
10-30	Array Index	0 N/A	2 set-ups	TRUE	0	Uint8
10-31	Store Data Values	[0] Off	All set-ups	TRUE	-	Uint8
10-32	DeviceNet Revision	SR	All set-ups	TRUE	0	Uint16
10-33	Store Always	[0] Off	1 set-up	TRUE	-	Uint8
10-34	DeviceNet Product Code	120 N/A	1 set-up	TRUE	0	Uint16
10-39	DeviceNet F Parameters	0 N/A	All set-ups	TRUE	0	Uint32

7.2.12. 13-** Smart Logic

Par. No. #	Parameter description	Default value	4 set-up	Change during operation	Conversion index	Type
13-0* SLC Settings						
13-00	SL Controller Mode	null	2 set-ups	TRUE	-	UInt8
13-01	Start Event	null	2 set-ups	TRUE	-	UInt8
13-02	Stop Event	null	2 set-ups	TRUE	-	UInt8
13-03	Reset SLC	[0] Do not reset SLC	All set-ups	TRUE	-	UInt8
13-1* Comparators						
13-10	Comparator Operand	null	2 set-ups	TRUE	-	UInt8
13-11	Comparator Operator	null	2 set-ups	TRUE	-	UInt8
13-12	Comparator Value	SR	2 set-ups	TRUE	-3	Int32
13-2* Timers						
13-20	SL Controller Timer	SR	1 set-up	TRUE	-3	TimD
13-4* Logic Rules						
13-40	Logic Rule Boolean 1	null	2 set-ups	TRUE	-	UInt8
13-41	Logic Rule Operator 1	null	2 set-ups	TRUE	-	UInt8
13-42	Logic Rule Boolean 2	null	2 set-ups	TRUE	-	UInt8
13-43	Logic Rule Operator 2	null	2 set-ups	TRUE	-	UInt8
13-44	Logic Rule Boolean 3	null	2 set-ups	TRUE	-	UInt8
13-5* States						
13-51	SL Controller Event	null	2 set-ups	TRUE	-	UInt8
13-52	SL Controller Action	null	2 set-ups	TRUE	-	UInt8

7.2.13. 14- * * Special Functions

Par. No. #	Parameter description	Default value	4 set-up	Change during operation	Conversion index	Type
14-0* Inverter Switching						
14-00	Switching Pattern	[0] 60 AVM	All set-ups	TRUE	-	Uint8
14-01	Switching Frequency	null	All set-ups	TRUE	-	Uint8
14-03	Overmodulation	[1] On	All set-ups	FALSE	-	Uint8
14-04	PWM Random	[0] Off	All set-ups	TRUE	-	Uint8
14-1* Line Supply On/Off						
14-12	Function at Line Imbalance	[3] Derate	All set-ups	TRUE	-	Uint8
14-2* Reset Functions						
14-20	Reset Mode	[10] Automatic reset x 10	All set-ups	TRUE	-	Uint8
14-21	Automatic Restart Time	10 s	All set-ups	TRUE	0	Uint16
14-22	Operation Mode	[0] Normal operation	All set-ups	TRUE	-	Uint8
14-23	Typecode Setting	null	2 set-ups	FALSE	-	Uint16
14-25	Trip Delay at Torque Limit	60 s	All set-ups	TRUE	0	Uint8
14-26	Trip Delay at Inverter Fault	SR	All set-ups	TRUE	0	Uint8
14-28	Production Settings	[0] No action	All set-ups	TRUE	-	Uint8
14-29	Service Code	0 N/A	All set-ups	TRUE	0	Int32
14-3* Current Limit Ctrl.						
14-30	Current Lim Ctrl, Proportional Gain	100 %	All set-ups	FALSE	0	Uint16
14-31	Current Lim Ctrl, Integration Time	0.020 s	All set-ups	FALSE	-3	Uint16
14-4* Energy Optimizing						
14-40	VT Level	66 %	All set-ups	FALSE	0	Uint8
14-41	AEO Minimum Magnetization	40 %	All set-ups	TRUE	0	Uint8
14-42	Minimum AEO Frequency	10 Hz	All set-ups	TRUE	0	Uint8
14-43	Motor Cos-Phi	SR	All set-ups	TRUE	-2	Uint16
14-5* Environment						
14-50	RFI Filter	[1] On	1 set-up	FALSE	-	Uint8
14-52	Fan Control	[0] Auto	All set-ups	TRUE	-	Uint8
14-53	Fan Monitor	[1] Warning	All set-ups	TRUE	-	Uint8
14-6* Auto Derate						
14-60	Function at Overtemperature	[1] Derate	All set-ups	TRUE	-	Uint8
14-61	Function at Inverter Overload	[1] Derate	All set-ups	TRUE	-	Uint8
14-62	Inv. Overload Derate Current	95 %	All set-ups	TRUE	0	Uint16

7.2.14. 15-** FC Information

Par. No. #	Parameter description	Default value	4 set-up	Change during operation	Conversion index	Type
15-0* Operating Data						
15-00	Operating Hours	0 h	All set-ups	FALSE	74	UInt32
15-01	Running Hours	0 h	All set-ups	FALSE	74	UInt32
15-02	kWh Counter	0 kWh	All set-ups	FALSE	75	UInt32
15-03	Power-ups	0 N/A	All set-ups	FALSE	0	UInt32
15-04	Overtmps	0 N/A	All set-ups	FALSE	0	UInt16
15-05	Overtolts	0 N/A	All set-ups	FALSE	0	UInt16
15-06	Reset kWh Counter	[0] Do not reset	All set-ups	TRUE	-	UInt8
15-07	Reset Running Hours Counter	[0] Do not reset	All set-ups	TRUE	-	UInt8
15-08	Number of Starts	0 N/A	All set-ups	FALSE	0	UInt32
15-1* Data Log Settings						
15-10	Logging Source	0	2 set-ups	TRUE	-	UInt16
15-11	Logging Interval	SR	2 set-ups	TRUE	-3	TimD
15-12	Trigger Event	[0] False	1 set-up	TRUE	-	UInt8
15-13	Logging Mode	[0] Log always	2 set-ups	TRUE	-	UInt8
15-14	Samples Before Trigger	50 N/A	2 set-ups	TRUE	0	UInt8
15-2* Historic Log						
15-20	Historic Log: Event	0 N/A	All set-ups	FALSE	0	UInt8
15-21	Historic Log: Value	0 N/A	All set-ups	FALSE	0	UInt32
15-22	Historic Log: Time	0 ms	All set-ups	FALSE	-3	UInt32
15-23	Historic Log: Date and Time	SR	All set-ups	FALSE	0	TimeOfDay
15-3* Alarm Log						
15-30	Alarm Log: Error Code	0 N/A	All set-ups	FALSE	0	UInt8
15-31	Alarm Log: Value	0 N/A	All set-ups	FALSE	0	UInt16
15-32	Alarm Log: Time	0 s	All set-ups	FALSE	0	UInt32
15-33	Alarm Log: Date and Time	SR	All set-ups	FALSE	0	TimeOfDay
15-4* Drive Identification						
15-40	FC Type	0 N/A	All set-ups	FALSE	0	VisStr[6]
15-41	Power Section	0 N/A	All set-ups	FALSE	0	VisStr[20]
15-42	Voltage	0 N/A	All set-ups	FALSE	0	VisStr[20]
15-43	Software Version	0 N/A	All set-ups	FALSE	0	VisStr[5]
15-44	Ordered Typecode String	0 N/A	All set-ups	FALSE	0	VisStr[40]
15-45	Actual Typecode String	0 N/A	All set-ups	FALSE	0	VisStr[40]
15-46	Adjustable Frequency Drive Ordering No.	0 N/A	All set-ups	FALSE	0	VisStr[8]
15-47	Power Card Ordering No.	0 N/A	All set-ups	FALSE	0	VisStr[8]
15-48	LCP ID No	0 N/A	All set-ups	FALSE	0	VisStr[20]
15-49	SW ID Control Card	0 N/A	All set-ups	FALSE	0	VisStr[20]
15-50	SW ID Power Card	0 N/A	All set-ups	FALSE	0	VisStr[20]
15-51	Adjustable Frequency Drive Serial Number	0 N/A	All set-ups	FALSE	0	VisStr[10]
15-53	Power Card Serial Number	0 N/A	All set-ups	FALSE	0	VisStr[19]

Par. No. #	Parameter description	Default value	4 set-up	Change during operation	Conversion index	Type
15-6* Option Ident						
15-60	Option Mounted	0 N/A	All set-ups	FALSE	0	VisStr[30]
15-61	Option SW Version	0 N/A	All set-ups	FALSE	0	VisStr[20]
15-62	Option Ordering No	0 N/A	All set-ups	FALSE	0	VisStr[8]
15-63	Option Serial No	0 N/A	All set-ups	FALSE	0	VisStr[18]
15-70	Option in Slot A	0 N/A	All set-ups	FALSE	0	VisStr[30]
15-71	Slot A Option SW Version	0 N/A	All set-ups	FALSE	0	VisStr[20]
15-72	Option in Slot B	0 N/A	All set-ups	FALSE	0	VisStr[30]
15-73	Slot B Option SW Version	0 N/A	All set-ups	FALSE	0	VisStr[20]
15-74	Option in Slot C0	0 N/A	All set-ups	FALSE	0	VisStr[30]
15-75	Slot C0 Option SW Version	0 N/A	All set-ups	FALSE	0	VisStr[20]
15-76	Option in Slot C1	0 N/A	All set-ups	FALSE	0	VisStr[30]
15-77	Slot C1 Option SW Version	0 N/A	All set-ups	FALSE	0	VisStr[20]
15-9* Parameter Info						
15-92	Defined Parameters	0 N/A	All set-ups	FALSE	0	Uint16
15-93	Modified Parameters	0 N/A	All set-ups	FALSE	0	Uint16
15-99	Parameter Metadata	0 N/A	All set-ups	FALSE	0	Uint16

7.2.15. 16- ** Data Readouts

Par. No. #	Parameter description	Default value	4 set-up	Change during operation	Conversion index	Type
16-0* General Status						
16-00	Control Word	0 N/A	All set-ups	FALSE	0	V2
16-01	Reference [Unit]	0.000 ReferenceFeedbackUnit	All set-ups	FALSE	-3	Int32
16-02	Reference [%]	0.0 %	All set-ups	FALSE	-1	Int16
16-03	Status Word	0 N/A	All set-ups	FALSE	0	V2
16-05	Main Actual Value [%]	0.00 %	All set-ups	FALSE	-2	N2
16-09	Custom Readout	0.00 CustomReadoutUnit	All set-ups	FALSE	-2	Int32
16-1* Motor Status						
16-10	Power [kW]	0.00 kW	All set-ups	FALSE	1	Int32
16-11	Power [HP]	0.00 hp	All set-ups	FALSE	-2	Int32
16-12	Motor Voltage	0.0 V	All set-ups	FALSE	-1	Uint16
16-13	Frequency	0.0 Hz	All set-ups	FALSE	-1	Uint16
16-14	Motor Current	0.00 A	All set-ups	FALSE	-2	Int32
16-15	Frequency [%]	0.00 %	All set-ups	FALSE	-2	N2
16-16	Torque [Nm]	0.0 Nm	All set-ups	FALSE	-1	Int16
16-17	Speed [RPM]	0 RPM	All set-ups	FALSE	67	Int32
16-18	Motor Thermal	0 %	All set-ups	FALSE	0	Uint8
16-22	Torque [%]	0 %	All set-ups	FALSE	0	Int16
16-3* Drive Status						
16-30	DC Link Voltage	0 V	All set-ups	FALSE	0	Uint16
16-32	Braking Energy /s	0.000 kW	All set-ups	FALSE	0	Uint32
16-33	Brake Energy/2 min	0.000 kW	All set-ups	FALSE	0	Uint32
16-34	Heatsink Temp.	0 °C	All set-ups	FALSE	100	Uint8
16-35	Inverter Thermal	0 %	All set-ups	FALSE	0	Uint8
16-36	Inv. Nom. Current	SR	All set-ups	FALSE	-2	Uint32
16-37	Inv. Max. Current	SR	All set-ups	FALSE	-2	Uint32
16-38	SL Controller State	0 N/A	All set-ups	FALSE	0	Uint8
16-39	Control Card Temp.	0 °C	All set-ups	FALSE	100	Uint8
16-40	Logging Buffer Full	[0] No	All set-ups	TRUE	-	Uint8
16-5* Ref. & Feedb.						
16-50	External Reference	0.0 N/A	All set-ups	FALSE	-1	Int16
16-52	Feedback [Unit]	0.000 ProcessCtrlUnit	All set-ups	FALSE	-3	Int32
16-53	DigiPot Reference	0.00 N/A	All set-ups	FALSE	-2	Int16
16-54	Feedback 1 [Unit]	0.000 ProcessCtrlUnit	All set-ups	FALSE	-3	Int32
16-55	Feedback 2 [Unit]	0.000 ProcessCtrlUnit	All set-ups	FALSE	-3	Int32
16-56	Feedback 3 [Unit]	0.000 ProcessCtrlUnit	All set-ups	FALSE	-3	Int32
16-59	Adjusted Setpoint		All set-ups	FALSE	-3	Int32

Par. No. #	Parameter description	Default value	4 set-up	Change during operation	Conversion index	Type
16-6* Inputs & Outputs						
16-60	Digital Input	0 N/A	All set-ups	FALSE	0	Uint16
16-61	Terminal 53 Switch Setting	[0] Current	All set-ups	FALSE	-	Uint8
16-62	Analog Input 53	0.000 N/A	All set-ups	FALSE	-3	Int32
16-63	Terminal 54 Switch Setting	[0] Current	All set-ups	FALSE	-	Uint8
16-64	Analog Input 54	0.000 N/A	All set-ups	FALSE	-3	Int32
16-65	Analog Output 42 [mA]	0.000 N/A	All set-ups	FALSE	-3	Int16
16-66	Digital Output [bin]	0 N/A	All set-ups	FALSE	0	Int16
16-67	Pulse Input #29 [Hz]	0 N/A	All set-ups	FALSE	0	Int32
16-68	Pulse Input #33 [Hz]	0 N/A	All set-ups	FALSE	0	Int32
16-69	Pulse Output #27 [Hz]	0 N/A	All set-ups	FALSE	0	Int32
16-70	Pulse Output #29 [Hz]	0 N/A	All set-ups	FALSE	0	Int32
16-71	Relay Output [bin]	0 N/A	All set-ups	FALSE	0	Int16
16-72	Counter A	0 N/A	All set-ups	TRUE	0	Int32
16-73	Counter B	0 N/A	All set-ups	TRUE	0	Int32
16-75	Analog In X30/11	0.000 N/A	All set-ups	FALSE	-3	Int32
16-76	Analog In X30/12	0.000 N/A	All set-ups	FALSE	-3	Int32
16-77	Analog Out X30/8 [mA]	0.000 N/A	All set-ups	FALSE	-3	Int16
16-8* Ser. Com. Bus & FC Port						
16-80	Ser. Com. Bus CTW 1	0 N/A	All set-ups	FALSE	0	V2
16-82	Ser. com. bus REF 1	0 N/A	All set-ups	FALSE	0	N2
16-84	Comm. Option STW	0 N/A	All set-ups	FALSE	0	V2
16-85	FC Port CTW 1	0 N/A	All set-ups	FALSE	0	V2
16-86	FC Port REF 1	0 N/A	All set-ups	FALSE	0	N2
16-9* Diagnosis Readouts						
16-90	Alarm Word	0 N/A	All set-ups	FALSE	0	Uint32
16-91	Alarm Word 2	0 N/A	All set-ups	FALSE	0	Uint32
16-92	Warning Word	0 N/A	All set-ups	FALSE	0	Uint32
16-93	Warning Word 2	0 N/A	All set-ups	FALSE	0	Uint32
16-94	Ext. Status Word	0 N/A	All set-ups	FALSE	0	Uint32
16-95	Ext. Status Word 2	0 N/A	All set-ups	FALSE	0	Uint32
16-96	Maintenance Word	0 N/A	All set-ups	FALSE	0	Uint32

7.2.16. 18- ** Data Readouts 2

Par. No. #	Parameter description	Default value	4 set-up	Change during operation	Conversion index	Type
18-0* Maintenance Log						
18-00	Maintenance Log: Item	0 N/A	All set-ups	FALSE	0	Uint8
18-01	Maintenance Log: Action	0 N/A	All set-ups	FALSE	0	Uint8
18-02	Maintenance Log: Time	0 s	All set-ups	FALSE	0	Uint32
18-03	Maintenance Log: Date and Time	SR	All set-ups	FALSE	0	TimeOfDay
18-3* Inputs & Outputs						
18-30	Analog Input X42/1	0.000 N/A	All set-ups	FALSE	-3	Int32
18-31	Analog Input X42/3	0.000 N/A	All set-ups	FALSE	-3	Int32
18-32	Analog Input X42/5	0.000 N/A	All set-ups	FALSE	-3	Int32
18-33	Analog Out X42/7 [V]	0.000 N/A	All set-ups	FALSE	-3	Int16
18-34	Analog Out X42/9 [V]	0.000 N/A	All set-ups	FALSE	-3	Int16
18-35	Analog Out X42/11 [V]	0.000 N/A	All set-ups	FALSE	-3	Int16

7.2.17. 20- ** FC Closed-loop

Par. No. #	Parameter description	Default value	4 set-up	Change during operation	Conversion index	Type
20-0* Feedback						
20-00	Feedback 1 Source	[2] Analog input 54	All set-ups	TRUE	-	Uint8
20-03	Feedback 2 Source	[0] No function	All set-ups	TRUE	-	Uint8
20-06	Feedback 3 Source	[0] No function	All set-ups	TRUE	-	Uint8
20-07	Feedback 3 Conversion	[0] Linear	All set-ups	TRUE	-	-
20-09	Feedback 4 Source	[0] No function	All set-ups	TRUE	-	Uint8
20-11	Feedback 4 Source Unit	null	All set-ups	TRUE	-	Uint8
20-12	Reference/Feedback Unit	null	All set-ups	TRUE	-	Uint8
20-2* Feedback & Setpoint						
20-20	Feedback Function	[4] Maximum	All set-ups	TRUE	-	Uint8
20-21	Setpoint 1	0.000 ProcessCtrlUnit	All set-ups	TRUE	-3	Int32
20-22	Setpoint 2	0.000 ProcessCtrlUnit	All set-ups	TRUE	-3	Int32
20-23	Setpoint 3	0.000 ProcessCtrlUnit	All set-ups	TRUE	-3	Int32
20-37* PID Auto-tuning						
20-70	Closed-loop Type	Auto	All set-ups	TRUE	-	-
20-71	PID Output Change	0.10	All set-ups	TRUE	-	-
20-72	Minimum Feedback Level	0.000 User Units	All set-ups	TRUE	-	-
20-73	Maximum Feedback Level	0.000 User Units	All set-ups	TRUE	-	-
20-74	Tuning Mode	Normal	All set-ups	TRUE	-	-
20-75	PID Auto-tuning	Disabled	All set-ups	TRUE	-	-
20-8* PID Basic Settings						
20-81	PID Normal/ Inverse Control	[0] Normal	All set-ups	TRUE	-	Uint8
20-82	PID Start Speed [RPM]	SR	All set-ups	TRUE	67	Uint16
20-83	PID Start Speed [Hz]	SR	All set-ups	TRUE	-1	Uint16
20-84	On Reference Bandwidth	5 %	All set-ups	TRUE	0	Uint8
20-9* PID Controller						
20-91	PID Anti Windup	[1] On	All set-ups	TRUE	-	Uint8
20-93	PID Proportional Gain	0.50 N/A	All set-ups	TRUE	-2	Uint16
20-94	PID Integral Time	20.00 s	All set-ups	TRUE	-2	Uint32
20-95	PID Differentiation Time	0.00 s	All set-ups	TRUE	-2	Uint16
20-96	PID Diff. Gain Limit	5.0 N/A	All set-ups	TRUE	-1	Uint16

7.2.18. 21-* * Ext. Closed-loop

Par. No. #	Parameter description	Default value	4 set-up	Change during operation	Conversion index	Type
21-1* Ext. CL 1 Ref./Fb.						
21-10	Ext. 1 Ref./Feedback Unit	[0]	All set-ups	TRUE	-	Uint8
21-11	Ext. 1 Minimum Reference	0.000 ExtPID1Unit	All set-ups	TRUE	-3	Int32
21-12	Ext. 1 Maximum Reference	100.000 ExtPID1Unit	All set-ups	TRUE	-3	Int32
21-13	Ext. 1 Reference Source	[0] No function	All set-ups	TRUE	-	Uint8
21-14	Ext. 1 Feedback Source	[0] No function	All set-ups	TRUE	-	Uint8
21-15	Ext. 1 Setpoint	0.000 ExtPID1Unit	All set-ups	TRUE	-3	Int32
21-17	Ext. 1 Reference [Unit]	0.000 ExtPID1Unit	All set-ups	TRUE	-3	Int32
21-18	Ext. 1 Feedback [Unit]	0.000 ExtPID1Unit	All set-ups	TRUE	-3	Int32
21-19	Ext. 1 Output [%]	0 %	All set-ups	TRUE	0	Int32
21-2* Ext. CL 1 PID						
21-20	Ext. 1 Normal/Inverse Control	[0] Normal	All set-ups	TRUE	-	Uint8
21-21	Ext. 1 Proportional Gain	0.5	All set-ups	TRUE	-2	Uint16
21-22	Ext. 1 Integral Time	20.0 s	All set-ups	TRUE	-2	Uint32
21-23	Ext. 1 Differentiation Time	0.00 s	All set-ups	TRUE	-2	Uint16
21-24	Ext. 1 Dif. Gain Limit	5.0 N/A	All set-ups	TRUE	-1	Uint16
21-3* Ext. CL 2 Ref./Fb.						
21-30	Ext. 2 Ref./Feedback Unit	[0]	All set-ups	TRUE	-	Uint8
21-31	Ext. 2 Minimum Reference	0.000 ExtPID2Unit	All set-ups	TRUE	-3	Int32
21-32	Ext. 2 Maximum Reference	100.000 ExtPID2Unit	All set-ups	TRUE	-3	Int32
21-33	Ext. 2 Reference Source	[0] No function	All set-ups	TRUE	-	Uint8
21-34	Ext. 2 Feedback Source	[0] No function	All set-ups	TRUE	-	Uint8
21-35	Ext. 2 Setpoint	0.000 ExtPID2Unit	All set-ups	TRUE	-3	Int32
21-37	Ext. 2 Reference [Unit]	0.000 ExtPID2Unit	All set-ups	TRUE	-3	Int32
21-38	Ext. 2 Feedback [Unit]	0.000 ExtPID2Unit	All set-ups	TRUE	-3	Int32
21-39	Ext. 2 Output [%]	0 %	All set-ups	TRUE	0	Int32
21-4* Ext. CL 2 PID						
21-40	Ext. 2 Normal/Inverse Control	[0] Normal	All set-ups	TRUE	-	Uint8
21-41	Ext. 2 Proportional Gain	0.5	All set-ups	TRUE	-2	Uint16
21-42	Ext. 2 Integral Time	20.0 s	All set-ups	TRUE	-2	Uint32
21-43	Ext. 2 Differentiation Time	0.00 s	All set-ups	TRUE	-2	Uint16
21-44	Ext. 2 Dif. Gain Limit	5.0 N/A	All set-ups	TRUE	-1	Uint16
21-5* Ext. CL 3 Ref./Fb.						
21-50	Ext. 3 Ref./Feedback Unit	[0]	All set-ups	TRUE	-	Uint8
21-51	Ext. 3 Minimum Reference	0.000 ExtPID3Unit	All set-ups	TRUE	-3	Int32
21-52	Ext. 3 Maximum Reference	100.000 ExtPID3Unit	All set-ups	TRUE	-3	Int32
21-53	Ext. 3 Reference Source	[0] No function	All set-ups	TRUE	-	Uint8
21-54	Ext. 3 Feedback Source	[0] No function	All set-ups	TRUE	-	Uint8
21-55	Ext. 3 Setpoint	0.000 ExtPID3Unit	All set-ups	TRUE	-3	Int32
21-57	Ext. 3 Reference [Unit]	0.000 ExtPID3Unit	All set-ups	TRUE	-3	Int32
21-58	Ext. 3 Feedback [Unit]	0.000 ExtPID3Unit	All set-ups	TRUE	-3	Int32
21-59	Ext. 3 Output [%]	0 %	All set-ups	TRUE	0	Int32

Par. No. #	Parameter description	Default value	4 set-up	FC 302 only	Change during operation	Conver- sion index	Type
21-6*	Ext. CL 3 PID						
21-60	Ext. 3 Normal/Inverse Control	[0] Normal	All set-ups		TRUE	-	Uint8
21-61	Ext. 3 Proportional Gain	0.5	All set-ups		TRUE	-2	Uint16
21-62	Ext. 3 Integral Time	20.0 s	All set-ups		TRUE	-2	Uint32
21-63	Ext. 3 Differentiation Time	0.00 s	All set-ups		TRUE	-2	Uint16
21-64	Ext. 3 Dif. Gain Limit	5.0 N/A	All set-ups		TRUE	-1	Uint16

7.2.19. 22-* Application Functions

Par. No. #	Parameter description	Default value	4 set-up	Change during operation	Conversion index	Type
22-0* Miscellaneous						
22-00	External Interlock Delay	0 s	All set-ups	TRUE	0	Uint16
22-2* No-Flow Detection						
22-20	Low Power Auto Set-up	[0] Off	All set-ups	FALSE	-	Uint8
22-21	Low Power Detection	[0] Disabled	All set-ups	TRUE	-	Uint8
22-22	Low Speed Detection	[0] Disabled	All set-ups	TRUE	-	Uint8
22-23	No-Flow Function	[0] Off	All set-ups	TRUE	-	Uint8
22-24	No-Flow Delay	10 s	All set-ups	TRUE	0	Uint16
22-26	Dry Pump Function	[0] Off	All set-ups	TRUE	-	Uint8
22-27	Dry Pump Delay	10 s	All set-ups	TRUE	0	Uint16
22-3* No-Flow Power Tuning						
22-30	No-Flow Power	0.00 kW	All set-ups	TRUE	1	Uint32
22-31	Power Correction Factor	100 %	All set-ups	TRUE	0	Uint16
22-32	Low Speed [RPM]	SR	All set-ups	TRUE	67	Uint16
22-33	Low Speed [Hz]	SR	All set-ups	TRUE	-1	Uint16
22-34	Low Speed Power [kW]	SR	All set-ups	TRUE	1	Uint32
22-35	Low Speed Power [HP]	SR	All set-ups	TRUE	-2	Uint32
22-36	High Speed [RPM]	SR	All set-ups	TRUE	67	Uint16
22-37	High Speed [Hz]	SR	All set-ups	TRUE	-1	Uint16
22-38	High Speed Power [kW]	SR	All set-ups	TRUE	1	Uint32
22-39	High Speed Power [HP]	SR	All set-ups	TRUE	-2	Uint32
22-4* Sleep Mode						
22-40	Minimum Run Time	60 s	All set-ups	TRUE	0	Uint16
22-41	Minimum Sleep Time	30 s	All set-ups	TRUE	0	Uint16
22-42	Wake-up Speed [RPM]	SR	All set-ups	TRUE	67	Uint16
22-43	Wake-up Speed [Hz]	SR	All set-ups	TRUE	-1	Uint16
22-44	Wake-up Ref./FB Difference	10 %	All set-ups	TRUE	0	Int8
22-45	Setpoint Boost	0 %	All set-ups	TRUE	0	Int8
22-46	Maximum Boost Time	60 s	All set-ups	TRUE	0	Uint16
22-5* End of Curve						
22-50	End of Curve Function	[0] Off	All set-ups	TRUE	-	Uint8
22-51	End of Curve Delay	10 s	All set-ups	TRUE	0	Uint16
22-6* Broken Belt Detection						
22-60	Broken Belt Function	[0] Off	All set-ups	TRUE	-	Uint8
22-61	Broken Belt Torque	10 %	All set-ups	TRUE	0	Uint8
22-62	Broken Belt Delay	10 s	All set-ups	TRUE	0	Uint16
22-7* Short Cycle Protection						
22-75	Short Cycle Protection	[0] Disabled	All set-ups	TRUE	-	Uint8
22-76	Interval between Starts	start_to_start_min_on_time (P2277)	All set-ups	TRUE	0	Uint16
22-77	Minimum Run Time	0 s	All set-ups	TRUE	0	Uint16

Par. No. #	Parameter description	Default value	4 set-up	Change during operation	Conversion index	Type
22-8* Flow Compensation						
22-80	Flow Compensation	[0] Disabled	All set-ups	TRUE	-	UInt8
22-81	Square-linear Curve Approximation	100 %	All set-ups	TRUE	0	UInt8
22-82	Work Point Calculation	[0] Disabled	All set-ups	TRUE	-	UInt8
22-83	Speed at No-Flow [RPM]	SR	All set-ups	TRUE	67	UInt16
22-84	Speed at No-Flow [Hz]	SR	All set-ups	TRUE	-1	UInt16
22-85	Speed at Design Point [RPM]	SR	All set-ups	TRUE	67	UInt16
22-86	Speed at Design Point [Hz]	SR	All set-ups	TRUE	-1	UInt16
22-87	Pressure at No-Flow Speed	0.000 ReferenceFeedbackUnit	All set-ups	TRUE	-3	Int32
22-88	Pressure at Rated Speed	999999.999 ReferenceFeedbackUnit	All set-ups	TRUE	-3	Int32
22-89	Flow at Design Point	0.000 N/A	All set-ups	TRUE	-3	Int32
22-90	Flow at Rated Speed	0.000 N/A	All set-ups	TRUE	-3	Int32

7.2.20. 23-** Timed Actions

Par. No. #	Parameter description	Default value	4 set-up	Change during operation	Conversion index	Type
23-0* Timed Actions						
23-00	ON Time	SR	2 set-ups	TRUE	0	TimeOfDay- WoDate UInt8
23-01	ON Action	[0] Disabled	2 set-ups	TRUE	-	TimeOfDay- WoDate UInt8
23-02	OFF Time	SR	2 set-ups	TRUE	0	TimeOfDay- WoDate UInt8
23-03	OFF Action	[0] Disabled	2 set-ups	TRUE	-	TimeOfDay- WoDate UInt8
23-04	Occurrence	[0] All days	2 set-ups	TRUE	-	TimeOfDay- WoDate UInt8
23-1* Maintenance						
23-10	Maintenance Item	[1] Motor bearings	1 set-up	TRUE	-	UInt8
23-11	Maintenance Action	[1] Lubricate	1 set-up	TRUE	-	UInt8
23-12	Maintenance Time Base	[0] Disabled	1 set-up	TRUE	-	UInt8
23-13	Maintenance Time Interval	1 h	1 set-up	TRUE	74	UInt32
23-14	Maintenance Date and Time	SR	1 set-up	TRUE	0	TimeOfDay
23-1* Maintenance Reset						
23-15	Reset Maintenance Word	[0] Do not reset	All set-ups	TRUE	-	UInt8
23-5* Energy Log						
23-50	Energy Log Resolution	[5] Last 24 Hours	2 set-ups	TRUE	-	UInt8
23-51	Period Start	SR	2 set-ups	TRUE	0	TimeOfDay
23-53	Energy Log	0 N/A	All set-ups	TRUE	0	UInt32
23-54	Reset Energy Log	[0] Do not reset	All set-ups	TRUE	-	UInt8
23-6* Trending						
23-60	Trend Variable	[0] Power [kW]	2 set-ups	TRUE	-	UInt8
23-61	Continuous Bin Data	0 N/A	All set-ups	TRUE	0	UInt32
23-62	Timed Bin Data	0 N/A	All set-ups	TRUE	0	UInt32
23-63	Timed Period Start	SR	2 set-ups	TRUE	0	TimeOfDay
23-64	Timed Period Stop	SR	2 set-ups	TRUE	0	TimeOfDay
23-65	Minimum Bin Value	SR	2 set-ups	TRUE	0	UInt8
23-66	Reset Continuous Bin Data	[0] Do not reset	All set-ups	TRUE	-	UInt8
23-67	Reset Timed Bin Data	[0] Do not reset	All set-ups	TRUE	-	UInt8
23-8* Payback Counter						
23-80	Power Reference Factor	100 %	2 set-ups	TRUE	0	UInt8
23-81	Energy Cost	1.00 N/A	2 set-ups	TRUE	-2	UInt32
23-82	Investment	0 N/A	2 set-ups	TRUE	0	UInt32
23-83	Energy Savings	0 kWh	All set-ups	TRUE	75	Int32
23-84	Cost Savings	0 N/A	All set-ups	TRUE	0	Int32

7.2.21. 25- ** Cascade Controller

Par. No. #	Parameter description	Default value	4 set-up	Change during operation	Conversion index	Type
25-0* System Settings						
25-00	Cascade Controller	[0] Disabled	2 set-ups	FALSE	-	Uint8
25-02	Motor Start	[0] Direct on Line	2 set-ups	FALSE	-	Uint8
25-04	Pump Cycling	[0] Disabled	All set-ups	TRUE	-	Uint8
25-05	Fixed Lead Pump	[1] Yes	2 set-ups	FALSE	-	Uint8
25-06	Number of Pumps	2 N/A	2 set-ups	FALSE	0	Uint8
25-2* Bandwidth Settings						
25-20	Staging Bandwidth	10 %	All set-ups	TRUE	0	Uint8
25-21	Override Bandwidth	100 %	All set-ups	TRUE	0	Uint8
25-22	Fixed Speed Bandwidth	casco_staging_bandwidth (P2520)	All set-ups	TRUE	0	Uint8
25-23	SBW Staging Delay	15 s	All set-ups	TRUE	0	Uint16
25-24	SBW De-staging Delay	15 s	All set-ups	TRUE	0	Uint16
25-25	OBW Time	10 s	All set-ups	TRUE	0	Uint16
25-26	De-stage At No-Flow	[0] Disabled	All set-ups	TRUE	-	Uint8
25-27	Stage Function	[1] Enabled	All set-ups	TRUE	-	Uint8
25-28	Stage Function Time	15 s	All set-ups	TRUE	0	Uint16
25-29	De-stage Function	[1] Enabled	All set-ups	TRUE	-	Uint8
25-30	De-stage Function Time	15 s	All set-ups	TRUE	0	Uint16
25-4* Staging Settings						
25-40	Ramp-down Delay	10.0 s	All set-ups	TRUE	-1	Uint16
25-41	Ramp-up Delay	2.0 s	All set-ups	TRUE	-1	Uint16
25-42	Staging Threshold	SR	All set-ups	TRUE	0	Uint8
25-43	De-staging Threshold	SR	All set-ups	TRUE	0	Uint8
25-44	Staging Speed [RPM]	0 RPM	All set-ups	TRUE	67	Uint16
25-45	Staging Speed [Hz]	0.0 Hz	All set-ups	TRUE	-1	Uint16
25-46	De-staging Speed [RPM]	0 RPM	All set-ups	TRUE	67	Uint16
25-47	De-staging Speed [Hz]	0.0 Hz	All set-ups	TRUE	-1	Uint16
25-5* Alternation Settings						
25-50	Lead Pump Alternation	[0] Off	All set-ups	TRUE	-	Uint8
25-51	Alternation Event	[0] External	All set-ups	TRUE	-	Uint8
25-52	Alternation Time Interval	24 h	All set-ups	TRUE	74	Uint16
25-53	Alternation Timer Value	0 N/A	All set-ups	TRUE	0	VisStr[7]
25-54	Alternation Predefined Time	SR	All set-ups	TRUE	0	TimeOfDay- WoDate
25-55	Alternates if Load < 50%	[1] Enabled	All set-ups	TRUE	-	Uint8
25-56	Staging Mode at Alternation	[0] Slow	All set-ups	TRUE	-	Uint8
25-58	Run Next Pump Delay	0.1 s	All set-ups	TRUE	-1	Uint16
25-59	Run-on Line Delay	0.5 s	All set-ups	TRUE	-1	Uint16

Par. No. #	Parameter description	Default value	4 set-up	Change during operation	Conversion index	Type
25-8* Status						
25-80	Cascade Status	0 N/A	All set-ups	TRUE	0	VisStr[25]
25-81	Pump Status	0 N/A	All set-ups	TRUE	0	VisStr[25]
25-82	Lead Pump	0 N/A	All set-ups	TRUE	0	Uint8
25-83	Relay Status	0 N/A	All set-ups	TRUE	0	VisStr[4]
25-84	Pump ON Time	0 h	All set-ups	TRUE	74	Uint32
25-85	Relay ON Time	0 h	All set-ups	TRUE	74	Uint32
25-86	Reset Relay Counters	[0] Do not reset	All set-ups	TRUE	-	Uint8
25-9* Service						
25-90	Pump Interlock	[0] Off	All set-ups	TRUE	-	Uint8
25-91	Manual Alternation	0 N/A	All set-ups	TRUE	0	Uint8

7.2.22. 26- * Analog I/O Option MCB 109

Par. No. #	Parameter description	Default value	4 set-up	Change during operation	Conversion index	Type
26-0* Analog I/O Mode						
26-00	Terminal X42/1 Mode	[1] Voltage	All set-ups	TRUE	-	Uint8
26-01	Terminal X42/3 Mode	[1] Voltage	All set-ups	TRUE	-	Uint8
26-02	Terminal X42/5 Mode	[1] Voltage	All set-ups	TRUE	-	Uint8
26-1* Analog Input X42/1						
26-10	Terminal X42/1 Low Voltage	0.07 V	All set-ups	TRUE	-2	Int16
26-11	Terminal X42/1 High Voltage	10.00 V	All set-ups	TRUE	-2	Int16
26-14	Term. X42/1 Low Ref./Feedb. Value	0.000 N/A	All set-ups	TRUE	-3	Int32
26-15	Term. X42/1 High Ref./Feedb. Value	100.000 N/A	All set-ups	TRUE	-3	Int32
26-16	Term. X42/1 Filter Time Constant	0.001 s	All set-ups	TRUE	-3	Uint16
26-17	Term. X42/1 Live Zero	[1] Enabled	All set-ups	TRUE	-	Uint8
26-2* Analog Input X42/3						
26-20	Terminal X42/3 Low Voltage	0.07 V	All set-ups	TRUE	-2	Int16
26-21	Terminal X42/3 High Voltage	10.00 V	All set-ups	TRUE	-2	Int16
26-24	Term. X42/3 Low Ref./Feedb. Value	0.000 N/A	All set-ups	TRUE	-3	Int32
26-25	Term. X42/3 High Ref./Feedb. Value	100.000 N/A	All set-ups	TRUE	-3	Int32
26-26	Term. X42/3 Filter Time Constant	0.001 s	All set-ups	TRUE	-3	Uint16
26-27	Term. X42/3 Live Zero	[1] Enabled	All set-ups	TRUE	-	Uint8
26-3* Analog Input X42/5						
26-30	Terminal X42/5 Low Voltage	0.07 V	All set-ups	TRUE	-2	Int16
26-31	Terminal X42/5 High Voltage	10.00 V	All set-ups	TRUE	-2	Int16
26-34	Term. X42/5 Low Ref./Feedb. Value	0.000 N/A	All set-ups	TRUE	-3	Int32
26-35	Term. X42/5 High Ref./Feedb. Value	100.000 N/A	All set-ups	TRUE	-3	Int32
26-36	Term. X42/5 Filter Time Constant	0.001 s	All set-ups	TRUE	-3	Uint16
26-37	Term. X42/5 Live Zero	[1] Enabled	All set-ups	TRUE	-	Uint8
26-4* Analog Output X42/7						
26-40	Terminal X42/7 Output	[0] No operation	All set-ups	TRUE	-	Uint8
26-41	Terminal X42/7 Min. Scale	0.00 %	All set-ups	TRUE	-2	Int16
26-42	Terminal X42/7 Max. Scale	100.00 %	All set-ups	TRUE	-2	Int16
26-43	Terminal X42/7 Output Bus Control	0.00 %	All set-ups	TRUE	-2	N2
26-44	Terminal X42/7 Output Timeout Preset	0.00 %	1 set-up	TRUE	-2	Uint16
26-5* Analog Output X42/9						
26-50	Terminal X42/9 Output	[0] No operation	All set-ups	TRUE	-	Uint8
26-51	Terminal X42/9 Min. Scale	0.00 %	All set-ups	TRUE	-2	Int16
26-52	Terminal X42/9 Max. Scale	100.00 %	All set-ups	TRUE	-2	Int16
26-53	Terminal X42/9 Output Bus Control	0.00 %	All set-ups	TRUE	-2	N2
26-54	Terminal X42/9 Output Timeout Preset	0.00 %	1 set-up	TRUE	-2	Uint16
26-6* Analog Output X42/11						
26-60	Terminal X42/11 Output	[0] No operation	All set-ups	TRUE	-	Uint8
26-61	Terminal X42/11 Min. Scale	0.00 %	All set-ups	TRUE	-2	Int16
26-62	Terminal X42/11 Max. Scale	100.00 %	All set-ups	TRUE	-2	Int16
26-63	Terminal X42/11 Output Bus Control	0.00 %	All set-ups	TRUE	-2	N2
26-64	Terminal X42/11 Output Timeout Preset	0.00 %	1 set-up	TRUE	-2	Uint16

7.2.23. 29- * * Water Application Functions

Par. No. #	Parameter description	Default value	4 set-up	Change during operation	Conversion index	Type
29-0* Pipe Fill						
29-00	Pipe Fill Enable	Disabled	All set-ups	TRUE	-	-
29-01	Pipe Fill Speed [RPM]	Motor Speed Low Limit	All set-ups	TRUE	-	-
29-02	Pipe Fill Speed [Hz]	Motor Speed Low Limit	All set-ups	TRUE	-	-
29-03	Pipe Fill Time	0	All set-ups	TRUE	-	-
29-04	Pipe Fill Rate	-	All set-ups	TRUE	-	-
29-05	Filled Setpoint	0	All set-ups	TRUE	-	-

7.2.24. 31-**-** Bypass Option

Par. No. #	Parameter description	Default value	4 set-up	Change during operation	Conversion index	Type
31-00	Bypass Mode	[0] Drive	All set-ups	TRUE	-	Uint8
31-01	Bypass Start Time Delay	30 s	All set-ups	TRUE	0	Uint16
31-02	Bypass Trip Time Delay	0 s	All set-ups	TRUE	0	Uint16
31-03	Test Mode Activation	[0] Disabled	All set-ups	TRUE	-	Uint8
31-10	Bypass Status Word	0 N/A	All set-ups	FALSE	0	V2
31-11	Bypass Running Hours	0 h	All set-ups	FALSE	74	Uint32
31-19	Remote Bypass Activation	[0] Disabled	2 set-ups	TRUE	-	Uint8

8. Troubleshooting

8.1. Alarms and warnings

A warning or an alarm is signaled by the relevant LED on the front of the adjustable frequency drive, indicated by a code on the display.

A warning remains active until its cause is no longer present. Under certain circumstances, operation of the motor may still be continued. Warning messages may be critical, but are not necessarily so.

In the event of an alarm, the adjustable frequency drive will have tripped. Alarms must be reset to restart operation once their cause has been rectified. This may be done in four ways:

1. By using the [RESET] control button on the LCP control panel.
2. Via a digital input with the "Reset" function.
3. Via serial communication/optional serial communication bus.
4. When resetting automatically using the [Auto Reset] function, which is a default setting for VLT AQUA Drive, see par. 14-20 Reset Mode in **VLT AQUA Drive Programming Guide**.



NOTE

After a manual reset using the [RESET] button on the LCP, the [AUTO ON] or [HAND ON] button must be pressed to restart the motor.

If an alarm cannot be reset, the reason may be that its cause has not been rectified, or that the alarm is trip-locked (see also the table on following page).

Alarms that are trip-locked offer additional protection; this means that the line supply must be switched off before the alarm can be reset. After being switched back on, the adjustable frequency drive is no longer blocked and may be reset as described above, once the cause has been rectified.

Alarms that are not trip-locked can also be reset using the automatic reset function in parameter 14-20 (Warning: automatic wake-up is possible!)

If a warning and alarm is marked against a code in the table on the following page, this means that either a warning occurs before an alarm, or that it can be specified whether it is a warning or an alarm that is to be displayed for a given fault.

This is possible, for instance, in parameter 1-90 *Motor Thermal Protection*. After an alarm or trip, the motor carries on coasting, and the alarm and warning flash on the adjustable frequency drive. Once the problem has been rectified, only the alarm continues flashing.

No.	Description	Warning	Alarm/Trip	Alarm/Trip Lock	Parameter Reference
1	10 Volts low	X			
2	Live zero error	(X)	(X)		6-01
3	No motor	(X)			1-80
4	Line phase loss	(X)	(X)	(X)	14-12
5	DC link voltage high	X			
6	DC link voltage low	X			
7	DC overvoltage	X	X		
8	DC undervoltage	X	X		
9	Inverter overloaded	X	X		
10	Motor ETR overtemperature	(X)	(X)		1-90
11	Motor thermistor overtemperature	(X)	(X)		1-90
12	Torque limit	X	X		
13	Overcurrent	X	X	X	
14	Ground fault	X	X	X	
15	Hardware mismatch		X	X	
16	Short Circuit		X	X	
17	Control word timeout	(X)	(X)		8-04
25	Brake resistor short-circuited	X			
26	Brake resistor power limit	(X)	(X)		2-13
27	Brake chopper short-circuited	X	X		
28	Brake check	(X)	(X)		2-15
29	Power board overtemp.	X	X	X	
30	Motor phase U missing	(X)	(X)	(X)	4-58
31	Motor phase V missing	(X)	(X)	(X)	4-58
32	Motor phase W missing	(X)	(X)	(X)	4-58
33	Soft-charge fault		X	X	
34	Serial communication bus fault	X	X		
38	Internal fault		X	X	
47	24 V supply low	X	X	X	
48	1.8 V supply low		X	X	
50	AMA calibration failed		X		
51	AMA check U_{nom} and I_{nom}		X		
52	AMA low I_{nom}		X		
53	AMA motor too big		X		
54	AMA motor too small		X		
55	AMA parameter out of range		X		
56	AMA interrupted by user		X		
57	AMA timeout		X		
58	AMA internal fault	X	X		
59	Current limit	X			
61	Tracking Error	(X)	(X)		4-30
62	Output Frequency at Maximum Limit	X			
64	Voltage Limit	X			
65	Control Board Overtemperature	X	X	X	
66	Heatsink Temperature Low	X			
67	Option Configuration Has Changed		X		
68	Safe Stop Activated		X		
80	Drive Initialized to Default Value		X		

8.1: Alarm/Warning code list

(X) Dependent on parameter

LED indication	
Warning	yellow
Alarm	flashing red
Trip-locked	yellow and red

Alarm Word and Extended Status Word						
Bit	Hex	Dec	Alarm Word	Warning Word	Extended Word	Status
0	00000001	1	Brake Check	Brake Check	Ramping	
1	00000002	2	Pwr. Card Temp	Pwr. Card Temp	AMA Running	
2	00000004	4	Ground Fault	Ground Fault	Start CW/CCW	
3	00000008	8	Ctrl.Card Temp	Ctrl.Card Temp	Slow-down	
4	00000010	16	Ctrl. Word TO	Ctrl. Word TO	Catch Up	
5	00000020	32	Overcurrent	Overcurrent	Feedback High	
6	00000040	64	Torque Limit	Torque Limit	Feedback Low	
7	00000080	128	Motor Th Over	Motor Th Over	Output Current High	
8	00000100	256	Motor ETR Over	Motor ETR Over	Output Current Low	
9	00000200	512	Inverter Overld.	Inverter Overld.	Output Freq High	
10	00000400	1024	DC Undervolt	DC Undervolt	Output Freq Low	
11	00000800	2048	DC Overvolt	DC Overvolt	Brake Check OK	
12	00001000	4096	Short Circuit	DC Voltage Low	Braking Max	
13	00002000	8192	Soft-charge fault	DC Voltage High	Braking	
14	00004000	16384	Line ph. Loss	Line ph. Loss	Out of Speed Range	
15	00008000	32768	AMA Not OK	No Motor	OVC Active	
16	00010000	65536	Live Zero Error	Live Zero Error		
17	00020000	131072	Internal Fault	10 V Low		
18	00040000	262144	Brake Overload	Brake Overload		
19	00080000	524288	U-phase Loss	Brake Resistor		
20	00100000	1048576	V-phase Loss	Brake IGBT		
21	00200000	2097152	W-phase Loss	Speed Limit		
22	00400000	4194304	Ser. com. bus fault	Ser. com. bus fault		
23	00800000	8388608	24 V Supply Low	24 V Supply Low		
24	01000000	16777216	Line Failure	Line Failure		
25	02000000	33554432	1.8 V Supply Low	Current Limit		
26	04000000	67108864	Brake Resistor	Low Temp		
27	08000000	134217728	Brake IGBT	Voltage Limit		
28	10000000	268435456	Option Change	Unused		
29	20000000	536870912	Drive Initialized	Unused		
30	40000000	1073741824	Safe Stop	Unused		

8.2: Description of Alarm Word, Warning Word and Extended Status Word

The alarm words, warning words and extended status words can be read out for diagnosis via serial bus or optional serial communication bus. See also par. 16-90, 16-92, and 16-94.

8.1.1.

WARNING 1

10 Volts low:

The 10 V voltage from terminal 50 on the control card is below 10 V.

Remove some of the load from terminal 50, as the 10 V supply is overloaded. Max. 15 mA or minimum 590 ohm.

WARNING/ALARM 2

Live zero error:

The signal on terminal 53 or 54 is less than 50% of the value set in par. 6-10, 6-12, 6-20 or 6-22, respectively.

WARNING/ALARM 3**No motor:**

No motor has been connected to the output of the adjustable frequency drive.

WARNING/ALARM 4**Line phase loss:**

A phase is missing on the supply side, or the line voltage imbalance is too high.

This message also appears in case of a fault in the input rectifier on the adjustable frequency drive.

Check the supply voltage and supply currents to the adjustable frequency drive.

WARNING 5**DC link voltage high:**

The intermediate circuit voltage (DC) is higher than the overvoltage limit of the control system. The adjustable frequency drive is still active.

WARNING 6**DC link voltage low**

The intermediate circuit voltage (DC) is below the undervoltage limit of the control system. The adjustable frequency drive is still active.

WARNING/ALARM 7**DC overvoltage:**

If the intermediate circuit voltage exceeds the limit, the adjustable frequency drive trips after a given period of time.

Possible corrections:

- Connect a brake resistor
- Extend the ramp time
- Activate functions in par. 2-10
- Increase par. 14-26

Connect a brake resistor. Extend the ramp time

Alarm/warning limits:			
Voltage ranges	3 x 200-240 V	3 x 380-480 V	3 x 525-600 V
	[VDC]	[VDC]	[VDC]
Undervoltage	185	373	532
Voltage warning low	205	410	585
Voltage warning high (w/o brake - w/brake)	390/405	810/840	943/965
Overvoltage	410	855	975

The voltages stated are the intermediate circuit voltages of the adjustable frequency drive with a tolerance of $\pm 5\%$. The corresponding line voltage is the intermediate circuit voltage (DC link) divided by 1.35.

WARNING/ALARM 8**DC undervoltage:**

If the intermediate circuit voltage (DC) drops below the "voltage warning low" limit (see table above), the adjustable frequency drive checks if 24 V backup supply is connected.

If no 24 V backup supply is connected, the adjustable frequency drive trips after a given period of time, depending on the unit.

To check whether the supply voltage matches the adjustable frequency drive, see *Specifications*.

WARNING/ALARM 9**Inverter overloaded:**

The adjustable frequency drive is about to cut out because of an overload (too high current for too long). The counter for electronic, thermal inverter protection gives a warning at 98% and trips at 100%, while giving an alarm. Reset cannot be performed before counter is below 90%.

The fault is that the adjustable frequency drive is overloaded by more than 100% for too long.

WARNING/ALARM 10**Motor ETR overtemperature:**

According to the electronic thermal protection (ETR), the motor is too hot. It can be chosen if the adjustable frequency drive is to give a warning or an alarm when the counter reaches 100% in par. 1-90. The fault is that the

motor is overloaded by more than 100% for too long. Check that the motor par. 1-24 is set correctly.

WARNING/ALARM 11

Motor thermistor overtemp.:

The thermistor or the thermistor connection is disconnected. Decide whether the adjustable frequency drive is to give a warning or an alarm when the counter reaches 100% in par. 1-90. Make sure the thermistor is connected correctly between terminal 53 or 54 (analog voltage input) and terminal 50 (+10 V supply), or between terminal 18 or 19 (digital input PNP only) and terminal 50. If a KTY sensor is used, check for correct connection between terminal 54 and 55.

WARNING/ALARM 12

Torque limit:

The torque is higher than the value in par. 4-16 (in motor operation), or the torque is higher than the value in par. 4-17 (in regenerative operation).

WARNING/ALARM 13

Overcurrent:

The inverter peak current limit (approximately 200% of the rated current) is exceeded. The warning will last approximately 8-12 sec., then the adjustable frequency drive trips and issues an alarm. Turn off the adjustable frequency drive and check if the motor shaft can be turned and if the motor size matches the adjustable frequency drive.

ALARM 14

Ground fault:

There is a discharge from the output phases to ground, either in the cable between the adjustable frequency drive and the motor or in the motor itself.

Turn off the adjustable frequency drive and remove the ground fault.

ALARM 15

Incomplete hardware:

A fitted option is not handled by the present control board (hardware or software).

ALARM 16

Short-circuit:

There is a short-circuit in the motor or on the motor terminals.

Turn off the adjustable frequency drive and remove the short-circuit.

WARNING/ALARM 17

Control word timeout:

There is no communication to the adjustable frequency drive.

The warning will only be active when par. 8-04 is NOT set to *OFF*.

If par. 8-04 is set to *Stop* and *Trip*, a warning appears and the adjustable frequency drive ramps down until it trips, while giving an alarm.

par. 8-03 *Control word Timeout Time* could possibly be increased.

WARNING 25

Brake resistor short-circuited:

The brake resistor is monitored during operation. If it short-circuits, the brake function is disconnected and the warning appears. The adjustable frequency drive still works, but without the brake function. Turn off the adjustable frequency drive and replace the brake resistor (see par. 2-15 *Brake Check*).

ALARM/WARNING 26

Brake resistor power limit:

The power transmitted to the brake resistor is calculated as a percentage, as a mean value over the last 120 s, on the basis of the resistance value of the brake resistor (par. 2-11) and the intermediate circuit voltage. The warning is active when the dissipated braking energy is higher than 90%. If *Trip* [2] has been selected in par. 2-13, the adjustable frequency drive cuts out and issues this alarm when the dissipated braking energy is higher than 100%.

WARNING 27

Brake chopper fault:

The brake transistor is monitored during operation, and if it short-circuits, the brake function disconnects and the warning is issued. The adjustable frequency drive is still able to run, but since the brake transistor has short-

circuited, substantial power is transmitted to the brake resistor, even if it is inactive. Turn off the adjustable frequency drive and remove the brake resistor.



Warning: There is a risk of substantial power being transmitted to the brake resistor if the brake transistor is short-circuited.

ALARM/WARNING 28

Brake check failed:

Brake resistor fault: the brake resistor is not connected/working.

ALARM 29

Adjustable frequency drive over-temperature:

If the enclosure is IP 20 or IP 21/TYPE 1, the cut-out temperature of the heatsink is 203°F +9° [95°C +5°C], depending on the size of the adjustable frequency drive. The temperature fault cannot be reset until the temperature of the heatsink is below 158° C +5° F [70 °C +5° C].

The fault could be a result of:

- Ambient temperature too high
- Motor cable too long

ALARM 30

Motor phase U missing:

Motor phase U between the adjustable frequency drive and the motor is missing.

Turn off the adjustable frequency drive and check motor phase U.

ALARM 31

Motor phase V missing:

Motor phase V between the adjustable frequency drive and the motor is missing.

Turn off the adjustable frequency drive and check motor phase V.

ALARM 32

Motor phase W missing:

Motor phase W between the adjustable frequency drive and the motor is missing.

Turn off the adjustable frequency drive and check motor phase W.

ALARM 33

Soft-charge fault:

Too many power-ups have occurred within a short time period. See the chapter *Specifications* for the allowed number of power-ups within one minute.

WARNING/ALARM 34

Ser. com. bus fault:

The serial communication bus on the communication option card is not working.

WARNING 35

Out of frequency range:

This warning is issued if the output frequency has reached its *Warning speed low* (par. 4-52) or *Warning speed high* (par. 4-53). If the adjustable frequency drive is in *Process control, closed-loop* (par. 1-00), the warning is active in the display. If the adjustable frequency drive is not in this mode, bit 008000 *Out of frequency range* in extended status word is active but there is no warning in the display.

ALARM 38

Internal fault:

Contact the local Danfoss supplier.

WARNING 47

24 V supply low:

The external 24 V DC back-up power supply may be overloaded; otherwise, contact your local Danfoss supplier.

WARNING 48

1.8 V supply low:

Contact the local Danfoss supplier.

ALARM 50

AMA calibration failed:

Contact the local Danfoss supplier.

ALARM 51

AMA check Unom and Inom:

The setting of motor voltage, motor current and motor power is presumably wrong. Check the settings.

ALARM 52

AMA low Inom:

The motor current is too low. Check the settings.

ALARM 53

AMA motor too big:

The motor is too big for the AMA to be carried out.

ALARM 54

AMA motor too small:

The motor is too small for the AMA to be carried out.

ALARM 55

AMA par. out of range:

The par. values found from the motor are outside the acceptable range.

ALARM 56

AMA interrupted by user:

The AMA has been interrupted by the user.

ALARM 57

AMA timeout:

Try to start the AMA again a number of times, until the AMA is carried out. Please note that repeated runs may heat the motor to a level where the resistances R_s and R_r are increased. In most cases, however, this is not critical.

ALARM 58

AMA internal fault:

Contact the local Danfoss supplier.

WARNING 59

Current limit:

Contact the local Danfoss supplier.

WARNING 62

Output Frequency at Maximum Limit:

The output frequency is higher than the value set in par. 4-19.

WARNING 64

Voltage Limit:

The load and speed combinations demand a motor voltage higher than the actual DC link voltage.

WARNING/ALARM/TRIP 65

Control Card Overtemperature:

Control card overtemperature: The cut-out temperature of the control card is 176°F [80°C].

WARNING 66

Heatsink Temperature Low:

The heatsink temperature is measured at 32°F [0°C]. This could indicate that the temperature sensor is defective, and that the fan speed has increased to maximum, if the power part or control card is very hot.

ALARM 67

Option Configuration has Changed:

One or more options has either been added or removed since the last power-down.

ALARM 68

Safe Stop Activated:

Safe Stop has been activated. To resume normal operation, apply 24 V DC to terminal 37, then send a reset signal (via bus, digital I/O, or by pressing [RESET]). For correct and safe use of the Safe Stop function, follow the related information and instructions in the Design Guide

ALARM 70

Illegal Frequency Configuration:

Current combination of control board and power board is illegal.

ALARM 80

Initialization to Default Value:

Parameter settings are initialized to default setting after a manual (three-finger) reset.

9. Specifications

9.1. General Specifications

9.1.1. Line Supply 3 x 200-240 V AC

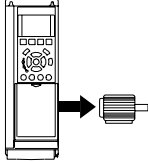
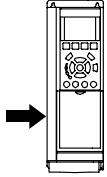
Normal overload 110% for 1 minute						
Line supply 200-240 V AC.						
Adjustable frequency drive	PK25	PK37	PK55	PK75		
Typical Shaft Output [kW]	0.25	0.37	0.55	0.75		
Typical Shaft Output [HP] at 208 V	0.3	0.5	0.75	1.0		
Encapsulation						
IP 20	A2	A2	A2	A2		
IP 55	A5	A5	A5	A5		
IP 66	A5	A5	A5	A5		
Output current						
	Continuous (3 x 200-240 V) [A]	1.8	2.4	3.5	4.6	
	Intermittent (3 x 200-240 V) [A]	2.9	3.8	5.6	7.4	
	Continuous kVA (208 V AC) [kVA]	0.65	0.86	1.26	1.66	
	Max. cable size: (line, motor, brake) [mm ² /AWG]	24 - 10 AWG 0.00031-0.0062 in. [0.2-4 mm] ²				
	Max. input current					
	Continuous (3 x 200-240 V) [A]	1.6	2.2	3.2	4.1	
	Intermittent (3 x 200-240 V) [A]	2.6	3.5	5.1	6.6	
	Max. pre-fuses ¹⁾ [A]	10	10	10	10	
	Environment					
	Estimated power loss at rated max. load [W] ⁴⁾	21	29	42	54	
Weight enclosure IP 20 [kg]	4.7	4.7	4.8	4.8		
Efficiency ⁴⁾	0.94	0.94	0.95	0.95		

1. For type of fuse, see section Fuses.
2. American Wire Gauge
3. Measured using 16.4 ft. [5 m] shielded motor cables at rated load and rated frequency.
4. The typical power loss is at nominal load conditions and expected to be within +/-15% (tolerance relates to variety in voltage and cable conditions).
Values are based on a typical motor efficiency (eff2/eff3 border line). Lower efficiency motors will also add to the power loss in the adjustable frequency drive and vice versa. If the switching frequency is raised from nominal, the power losses may rise significantly. LCP and typical control card power consumption values are included. Further options and customer load may add up to 30W to the losses (though typically only 4W extra for a fully loaded control card, or options for slot A or slot B, each).
Although measurements are made with state of the art equipment, some measurement inaccuracy must be allowed for (+/- 5%).

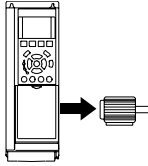
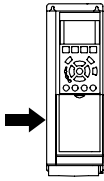
Normal overload 110% for 1 minute						
Line supply 200-240 V AC.						
Adjustable frequency drive	P1K1	P1K5	P2K2	P3K0	P3K7	
Typical Shaft Output [kW]	1.1	1.5	2.2	3	3.7	
Typical Shaft Output [HP] at 208 V	1.5	2	3	4	5	
Encapsulation						
IP 20	A2	A2	A2	A3	A3	
IP 55	A5	A5	A5	A5	A5	
IP 66	A5	A5	A5	A5	A5	
Output current						
	Continuous (3 x 200-240 V) [A]	6.6	7.5	10.6	12.5	16.7
	Intermittent (3 x 200-240 V) [A]	7.3	8.3	11.7	13.8	18.4
	Continuous kVA (208 V AC) [kVA]	2.38	2.70	3.82	4.50	6.00
	Max. cable size: (line, motor, brake) [mm ² /AWG]	4/10				
	Max. input current					
	Continuous (3 x 200-240 V) [A]	5.9	6.8	9.5	11.3	15.0
	Intermittent (3 x 200-240 V) [A]	6.5	7.5	10.5	12.4	16.5
	Max. pre-fuses ¹⁾ [A]	20	20	20	32	32
	Environment					
	Estimated power loss at rated max. load [W] ⁴⁾	63	82	116	155	185
Weight enclosure IP 20 [kg]	4.9	4.9	4.9	6.6	6.6	
Weight enclosure IP 21 [kg]	5.5	5.5	5.5	7.5	7.5	
Weight enclosure IP 55 [kg]	13.5	13.5	13.5	13.5	13.5	
Weight enclosure IP 66 [kg]	13.5	13.5	13.5	13.5	13.5	
Efficiency ⁴⁾	0.96	0.96	0.96	0.96	0.96	

1. For type of fuse, see section Fuses.
2. American Wire Gauge
3. Measured using 16.4 ft. [5 m] shielded motor cables at rated load and rated frequency.
4. The typical power loss is at nominal load conditions and expected to be within +/-15% (tolerance relates to variety in voltage and cable conditions).
Values are based on a typical motor efficiency (eff2/eff3 border line). Lower efficiency motors will also add to the power loss in the adjustable frequency drive and vice versa. If the switching frequency is raised from nominal, the power losses may rise significantly. LCP and typical control card power consumption values are included. Further options and customer load may add up to 30W to the losses (though typically only 4W extra for a fully loaded control card, or options for slot A or slot B, each).
Although measurements are made with state of the art equipment, some measurement inaccuracy must be allowed for (+/- 5%).

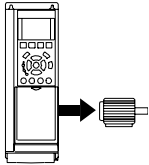
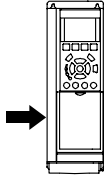
Normal overload 110% for 1 minute					
Line supply 200-240 V AC.					
Adjustable frequency drive	P5K5	P7K5	P11K	P15K	
Typical Shaft Output [kW]	5.5	7.5	11	15	
Typical Shaft Output [HP] at 208 V	7.5	10	15	20	
Encapsulation					
IP 21	B1	B1	B2	B2	
IP 55	B1	B1	B2	B2	
IP 66	B1	B1	B2	B2	
Output current					
	Continuous (3 x 200-240 V) [A]	24.2	30.8	46.2	59.4
	Intermittent (3 x 200-240 V) [A]	26.6	33.9	50.8	65.3
	Continuous kVA (208 V AC) [kVA]	8.7	11.1	16.6	21.4
	Max. cable size: (line, motor, brake) [mm ² /AWG]		10/7		35/2
	Max. input current				
	Continuous (3 x 200-240 V) [A]	22.0	28.0	42.0	54.0
	Intermittent (3 x 200-240 V) [A]	24.2	30.8	46.2	59.4
	Max. pre-fuses ¹⁾ [A]	63	63	63	80
	Environment				
	Estimated power loss at rated max. load [W] ⁴⁾	269	310	447	602
	Weight enclosure IP 20 [kg]				
	Weight enclosure IP 21 [kg]	23	23	23	27
Weight enclosure IP 55 [kg]	23	23	23	27	
Weight enclosure IP 66 [kg]	23	23	23	27	
Efficiency ⁴⁾	0.96	0.96	0.96	0.96	

1. For type of fuse, see section Fuses.
2. American Wire Gauge
3. Measured using 16.4 ft. [5 m] shielded motor cables at rated load and rated frequency.
4. The typical power loss is at nominal load conditions and expected to be within +/-15% (tolerance relates to variety in voltage and cable conditions).
Values are based on a typical motor efficiency (eff2/eff3 border line). Lower efficiency motors will also add to the power loss in the adjustable frequency drive and vice versa. If the switching frequency is raised from nominal, the power losses may rise significantly. LCP and typical control card power consumption values are included. Further options and customer load may add up to 30W to the losses (though typically only 4W extra for a fully loaded control card, or options for slot A or slot B, each).
Although measurements are made with state of the art equipment, some measurement inaccuracy must be allowed for (+/- 5%).

Normal overload 110% for 1 minute						
Line supply 200-240 V AC.						
Adjustable frequency drive						
Typical Shaft Output [kW]	P18K	P22K	P30K	P37K	P45K	
Typical Shaft Output [HP] at 208 V	25	30	40	50	60	
Encapsulation						
IP 21	C1	C1	C2	C2	C2	
IP 55	C1	C1	C2	C2	C2	
IP 66	C1	C1	C2	C2	C2	
Output current						
	Continuous (3 x 200-240 V) [A]	74.8	88.0	115	143	170
	Intermittent (3 x 200-240 V) [A]	82.3	96.8	127	157	187
	Continuous kVA (208 V AC) [kVA]	26.9	31.7	41.4	51.5	61.2
	Max. cable size: (line, motor, brake) [mm ² /AWG]	50/1/0		95/4/0		120/25 0 MCM
	Max. input current					
		Continuous (3 x 200-240 V) [A]	68.0	80.0	104.0	130.0
Intermittent (3 x 200-240 V) [A]		74.8	88.0	114.0	143.0	169.0
Max. pre-fuses ¹⁾ [A]		125	125	160	200	250
Environment						
Estimated power loss at rated max. load [W] ⁴⁾		737	845	1140	1353	1636
Weight enclosure IP 20 [kg]						
Weight enclosure IP 21 [kg]	45	45	65	65	65	
Weight enclosure IP 55 [kg]	45	45	65	65	65	
Weight enclosure IP 66 [kg]	45	45	65	65	65	
Efficiency ⁴⁾	0.96	0.97	0.97	0.97	0.97	

1. For type of fuse, see section Fuses.
2. American Wire Gauge
3. Measured using 16.4 ft. [5 m] shielded motor cables at rated load and rated frequency.
4. The typical power loss is at nominal load conditions and expected to be within +/-15% (tolerance relates to variety in voltage and cable conditions).
Values are based on a typical motor efficiency (eff2/eff3 border line). Lower efficiency motors will also add to the power loss in the adjustable frequency drive and vice versa. If the switching frequency is raised from nominal, the power losses may rise significantly. LCP and typical control card power consumption values are included. Further options and customer load may add up to 30W to the losses (though typically only 4W extra for a fully loaded control card, or options for slot A or slot B, each).
Although measurements are made with state of the art equipment, some measurement inaccuracy must be allowed for (+/- 5%).

9.1.2. Line Supply 3 x 380-480 V AC

Normal overload 110% for 1 minute							
Line Supply 3 x 380-480 V AC							
Adjustable frequency drive	PK37	PK55	PK75	P1K1	P1K5		
Typical Shaft Output [kW]	0.37	0.55	0.75	1.1	1.5		
Typical Shaft Output [HP] at 460 V	0.5	0.75	1	1.5	2		
Encapsulation							
IP 20	A2	A2	A2	A2	A2		
IP 21							
IP 55	A5	A5	A5	A5	A5		
IP 66	A5	A5	A5	A5	A5		
Output current							
	Continuous (3 x 380-440 V) [A]	1.3	1.8	2.4	3	4.1	
	Intermittent (3 x 380-440 V) [A]	2.1	2.9	3.8	3.3	4.5	
	Continuous (3 x 440-480 V) [A]	1.2	1.6	2.1	2.7	3.4	
	Intermittent (3 x 440-480 V) [A]	1.9	2.6	3.4	3.0	3.7	
	Continuous kVA (400 V AC) [kVA]	0.9	1.3	1.7	2.1	2.8	
	Continuous kVA (460 V AC) [kVA]	0.9	1.3	1.7	2.4	2.7	
	Max. cable size: (line, motor, brake) [[mm ² / AWG]	4/10					
	Max. input current						
		Continuous (3 x 380-440 V) [A]	1.2	1.6	2.2	2.7	3.7
		Intermittent (3 x 380-440 V) [A]	1.9	2.6	3.5	3.0	4.1
		Continuous (3 x 440-480 V) [A]	1.0	1.4	1.9	2.7	3.1
		Intermittent (3 x 440-480 V) [A]	1.6	2.2	3.0	3.0	3.4
Max. pre-fuses ¹⁾ [A]		10	10	10	10	10	
Environment							
Estimated power loss at rated max. load [W] ⁴⁾		35	42	46	58	62	
Weight enclosure IP 20 [kg]		4.7	4.7	4.8	4.8	4.9	
Weight enclosure IP 55 [kg]		13.5	13.5	13.5	13.5	13.5	
Efficiency ⁴⁾		0.93	0.95	0.96	0.96	0.97	

1. For type of fuse, see section Fuses.
2. American Wire Gauge
3. Measured using 16.4 ft. [5 m] shielded motor cables at rated load and rated frequency.
4. The typical power loss is at nominal load conditions and expected to be within +/-15% (tolerance relates to variety in voltage and cable conditions).
Values are based on a typical motor efficiency (eff2/eff3 border line). Lower efficiency motors will also add to the power loss in the adjustable frequency drive and vice versa. If the switching frequency is raised from nominal, the power losses may rise significantly. LCP and typical control card power consumption values are included. Further options and customer load may add up to 30W to the losses (though typically only 4W extra for a fully loaded control card, or options for slot A or slot B, each).
Although measurements are made with state of the art equipment, some measurement inaccuracy must be allowed for (+/- 5%).

Normal overload 110% for 1 minute							
Line Supply 3 x 380-480 V AC							
Adjustable frequency drive		P2K2	P3K0	P4K0	P5K5	P7K5	
Typical Shaft Output [kW]		2.2	3	4	5.5	7.5	
Typical Shaft Output [HP] at 460 V		3	4	5	7	10	
Encapsulation							
IP 20		A2	A2	A2	A3	A3	
IP 21							
IP 55		A5	A5	A5	A5	A5	
IP 66		A5	A5	A5	A5	A5	
Output current							
	Continuous (3 x 380-440 V) [A]	5.6	7.2	10	13	16	
	Intermittent (3 x 380-440 V) [A]	6.2	7.9	11	14.3	17.6	
	Continuous (3 x 440-480 V) [A]	4.8	6.3	8.2	11	14.5	
	Intermittent (3 x 440-480 V) [A]	5.3	6.9	9.0	12.1	15.4	
	Continuous kVA (400 V AC) [kVA]	3.9	5.0	6.9	9.0	11.0	
	Continuous kVA (460 V AC) [kVA]	3.8	5.0	6.5	8.8	11.6	
	Max. cable size: (line, motor, brake) [mm ² /AWG]						
	Max. input current						
		Continuous (3 x 380-440 V) [A]	5.0	6.5	9.0	11.7	14.4
		Intermittent (3 x 380-440 V) [A]	5.5	7.2	9.9	12.9	15.8
Continuous (3 x 440-480 V) [A]		4.3	5.7	7.4	9.9	13.0	
Intermittent (3 x 440-480 V) [A]		4.7	6.3	8.1	10.9	14.3	
Max. pre-fuses ¹⁾ [A]		20	20	20	32	32	
Environment							
Estimated power loss at rated max. load [W] ⁴⁾		88	116	124	187	255	
Weight enclosure IP 20 [kg]		4.9	4.9	4.9	6.6	6.6	
Weight enclosure IP 21 [kg]							
Weight enclosure IP 55 [kg]		13.5	13.5	13.5	14.2	14.2	
Weight enclosure IP 66 [kg]	13.5	13.5	13.5	14.2	14.2		
Efficiency ⁴⁾	0.97	0.97	0.97	0.97	0.97		

1. For type of fuse, see section Fuses.
2. American Wire Gauge
3. Measured using 16.4 ft. [5 m] shielded motor cables at rated load and rated frequency.
4. The typical power loss is at nominal load conditions and expected to be within +/-15% (tolerance relates to variety in voltage and cable conditions).
Values are based on a typical motor efficiency (eff2/eff3 border line). Lower efficiency motors will also add to the power loss in the adjustable frequency drive and vice versa. If the switching frequency is raised from nominal, the power losses may rise significantly. LCP and typical control card power consumption values are included. Further options and customer load may add up to 30W to the losses (though typically only 4W extra for a fully loaded control card, or options for slot A or slot B, each).
Although measurements are made with state of the art equipment, some measurement inaccuracy must be allowed for (+/- 5%).

Normal overload 110% for 1 minute						
Line Supply 3 x 380-480 V AC						
Adjustable frequency drive	P11K	P15K	P18K	P22K	P30K	
Typical Shaft Output [kW]	11	15	18.5	22	30	
Typical Shaft Output [HP] at 460 V	15	20	25	30	40	
Encapsulation						
IP 20						
IP 21	B1	B1	B1	B2	B2	
IP 55	B1	B1	B1	B2	B2	
IP 66	B1	B1	B1	B2	B2	
Output current						
	Continuous (3 x 380-440 V) [A]	24	32	37.5	44	61
	Intermittent (3 x 380-440 V) [A]	26.4	35.2	41.3	48.4	67.1
	Continuous (3 x 440-480 V) [A]	21	27	34	40	52
	Intermittent (3 x 440-480 V) [A]	23.1	29.7	37.4	44	61.6
	Continuous kVA (400 V AC) [kVA]	16.6	22.2	26	30.5	42.3
	Continuous kVA (460 V AC) [kVA]	16.7	21.5	27.1	31.9	41.4
	Max. cable size:					
	(line, motor, brake) [[mm ² / AWG]		10/7		35/2	
	Max. input current					
		Continuous (3 x 380-440 V) [A]	22	29	34	40
Intermittent (3 x 380-440 V) [A]		24.2	31.9	37.4	44	60.5
Continuous (3 x 440-480 V) [A]		19	25	31	36	47
Intermittent (3 x 440-480 V) [A]		20.9	27.5	34.1	39.6	51.7
Max. pre-fuses ¹⁾ [A]		63	63	63	63	80
Environment						
Estimated power loss at rated max. load [W] ⁴⁾		278	392	465	525	739
Weight enclosure IP 20 [kg]						
Weight enclosure IP 21 [kg]		23	23	23	27	27
Weight enclosure IP 55 [kg]		23	23	23	27	27
Weight enclosure IP 66 [kg]	23	23	23	27	27	
Efficiency ⁴⁾	0.98	0.98	0.98	0.98	0.98	

1. For type of fuse, see section Fuses.
2. American Wire Gauge
3. Measured using 16.4 ft. [5 m] shielded motor cables at rated load and rated frequency.
4. The typical power loss is at nominal load conditions and expected to be within +/-15% (tolerance relates to variety in voltage and cable conditions).
Values are based on a typical motor efficiency (eff2/eff3 border line). Lower efficiency motors will also add to the power loss in the adjustable frequency drive and vice versa. If the switching frequency is raised from nominal, the power losses may rise significantly. LCP and typical control card power consumption values are included. Further options and customer load may add up to 30W to the losses (though typically only 4W extra for a fully loaded control card, or options for slot A or slot B, each).
Although measurements are made with state of the art equipment, some measurement inaccuracy must be allowed for (+/- 5%).

Normal overload 110% for 1 minute							
Line Supply 3 x 380-480 V AC							
Adjustable frequency drive	P37K	P45K	P55K	P75K	P90K		
Typical Shaft Output [kW]	37	45	55	75	90		
Typical Shaft Output [HP] at 460 V	50	60	75	100	125		
Encapsulation							
IP 20							
IP 21	C1	C1	C1	C2	C2		
IP 55	C1	C1	C1	C2	C2		
IP 66	C1	C1	C1	C2	C2		
Output current							
	Continuous (3 x 380-440 V) [A]	73	90	106	147	177	
	Intermittent (3 x 380-440 V) [A]	80.3	99	117	162	195	
	Continuous (3 x 440-480 V) [A]	65	80	105	130	160	
	Intermittent (3 x 440-480 V) [A]	71.5	88	116	143	176	
	Continuous kVA (400 V AC) [kVA]	50.6	62.4	73.4	102	123	
	Continuous kVA (460 V AC) [kVA]	51.8	63.7	83.7	104	128	
	Max. cable size: (line, motor, brake) [[mm ² /AWG]		50/1/0		104	128	
	Max. input current						
		Continuous (3 x 380-440 V) [A]	66	82	96	133	161
		Intermittent (3 x 380-440 V) [A]	72.6	90.2	106	146	177
Continuous (3 x 440-480 V) [A]		59	73	95	118	145	
Intermittent (3 x 440-480 V) [A]		64.9	80.3	105	130	160	
Max. pre-fuses ¹⁾ [A]		100	125	160	250	250	
Environment							
Estimated power loss at rated max. load [W] ⁴⁾		698	843	1083	1384	1474	
Weight enclosure IP 20 [kg]							
Weight enclosure IP 21 [kg]		45	45	45	65	65	
Weight enclosure IP 55 [kg]		45	45	45	65	65	
Weight enclosure IP 66 [kg]	45	45	45	-	-		
Efficiency ⁴⁾	0.98	0.98	0.98	0.98	0.99		

1. For type of fuse, see section Fuses.
2. American Wire Gauge
3. Measured using 16.4 ft. [5 m] shielded motor cables at rated load and rated frequency.
4. The typical power loss is at nominal load conditions and expected to be within +/-15% (tolerance relates to variety in voltage and cable conditions).
Values are based on a typical motor efficiency (eff2/eff3 border line). Lower efficiency motors will also add to the power loss in the adjustable frequency drive and vice versa. If the switching frequency is raised from nominal, the power losses may rise significantly. LCP and typical control card power consumption values are included. Further options and customer load may add up to 30W to the losses (though typically only 4W extra for a fully loaded control card, or options for slot A or slot B, each).
Although measurements are made with state of the art equipment, some measurement inaccuracy must be allowed for (+/- 5%).

Protection and Features:

- Electronic thermal motor protection against overload.
- Temperature monitoring of the heatsink ensures that the adjustable frequency drive trips if the temperature reaches 203°F ± 9°F [95 °C ± 5°C]. An overload temperature cannot be reset until the temperature of the heatsink is below 158°C ± 9°C [70°C ± 5°C] (Guideline - these temperatures may vary for different power sizes, enclosures, etc.). VLT AQUA Drive has an auto-derating function to prevent its heatsink from reaching 203° F [95°C].
- The adjustable frequency drive is protected against short-circuits on motor terminals U, V, W.
- If a line phase is missing, the adjustable frequency drive trips or issues a warning (depending on the load).
- Monitoring of the intermediate circuit voltage ensures that the adjustable frequency drive trips if the intermediate circuit voltage is too low or too high.
- The adjustable frequency drive is protected against ground faults on motor terminals U, V, W.

Line power supply (L1, L2, L3):

Supply voltage	200-240 V ±10%
Supply voltage	380-480 V ±10%
Supply voltage	525-600 V ±10%
Supply frequency	50/60 Hz
Max. imbalance temporary between line phases	3.0% of rated supply voltage
True Power Factor (λ)	≥ 0.9 nominal at rated load
Displacement Power Factor ($\cos\phi$) near unity	(> 0.98)
Switching on input supply L1, L2, L3 (power-ups) ≤ enclosure type A	maximum twice/min.
Switching on input supply L1, L2, L3 (power-ups) ≥ enclosure type B, C	maximum once/min.
Environment according to EN60664-1	overvoltage category III/pollution degree 2

The unit is suitable for use on a circuit capable of delivering no more than 100,000 RMS symmetrical Amperes, 240/500/600 V maximum.

Motor output (U, V, W):

Output voltage	0 - 100% of supply voltage
Output frequency	0 - 1000 Hz
Switching on output	Unlimited
Ramp times	1 - 3600 sec.

Torque characteristics:

Starting torque (Constant torque)	maximum 110% for 1 min.*
Starting torque	maximum 135% up to 0.5 sec.*
Overload torque (Constant torque)	maximum 110% for 1 min.*

**Percentage relates to VLT AQUA Drive's nominal torque.*

Cable lengths and cross-sections:

Max. motor cable length, shielded/armored	VLT AQUA Drive: 492 ft [150 m]
Max. motor cable length, unshielded/unarmored	VLT AQUA Drive: 984 ft [300 m]
Max. cross-section to motor, line power, load sharing and brake *	
Maximum cross-section to control terminals, rigid wire	0.0023 in. ² [1.5 mm ²]/16 AWG (2 x 0.0012 in. ² [2 x 0.75 mm ²])

Maximum cross-section to control terminals, flexible cable	0.0016 in. ² [1 mm ²]/18 AWG
Maximum cross-section to control terminals, cable with enclosed core	0.00078 in. ² [0.5 mm ²]/20 AWG
Minimum cross-section to control terminals	0.00039 in. ² [0.25 mm ²]

* See Line Supply tables for more information!

Control card, RS-485 serial communication:

Terminal number	68 (P,TX+, RX+), 69 (N,TX-, RX-)
Terminal number 61	Common for terminals 68 and 69

The RS-485 serial communication circuit is functionally separated from other central circuits and galvanically isolated from the supply voltage (PELV).

Digital inputs:

Programmable digital inputs	4 (6)
Terminal number	18, 19, 27 ¹⁾ , 29, 32, 33,
Logic	PNP or NPN
Voltage level	0 - 24 V DC
Voltage level, logic '0' PNP	< 5 V DC
Voltage level, logic '1' PNP	> 10 V DC
Voltage level, logic '0' NPN	> 19 V DC
Voltage level, logic '1' NPN	< 14 V DC
Maximum voltage on input	28 V DC
Input resistance, R _i	approx. 4 kΩ

All digital inputs are galvanically isolated from the supply voltage (PELV) and other high-voltage terminals.

1) Terminals 27 and 29 can also be programmed as output.

Digital output:

Programmable digital/pulse outputs	2
Terminal number	27, 29 ¹⁾
Voltage level at digital/frequency output	0 - 24 V
Max. output current (sink or source)	40 mA
Max. load at frequency output	1 kΩ
Max. capacitive load at frequency output	10 nF
Minimum output frequency at frequency output	0 Hz
Maximum output frequency at frequency output	32 kHz
Accuracy of frequency output	Max. error: 0.1% of full scale
Resolution of output frequency	12 bit

1) Terminal 27 and 29 can also be programmed as input.

The digital output is galvanically isolated from the supply voltage (PELV) and other high-voltage terminals.

Analog inputs:

Number of analog inputs	2
Terminal number	53, 54
Modes	Voltage or current
Mode select	Switch S201 and switch S202
Voltage mode	Switch S201/switch S202 = OFF (U)

Voltage level	: 0 to + 10 V (scalable)
Input resistance, R_i	approx. 10 k Ω
Max. voltage	\pm 20 V
Current mode	Switch S201/switch S202 = ON (I)
Current level	0/4 to 20 mA (scalable)
Input resistance, R_i	approx. 200 Ω
Max. current	30 mA
Resolution for analog inputs	10 bit (+ sign)
Accuracy of analog inputs	Max. error 0.5% of full scale
Bandwidth	: 200 Hz

The analog inputs are galvanically isolated from the supply voltage (PELV) and other high-voltage terminals.

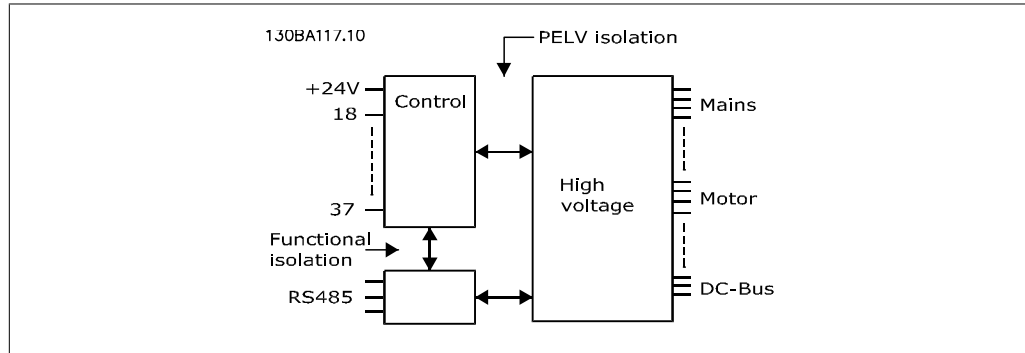

Analog output:	
Number of programmable analog outputs	1
Terminal number	42
Current range at analog output	0/4 - 20 mA
Max. load to common at analog output	500 Ω
Accuracy on analog output	Max. error: 0.8% of full scale
Resolution on analog output	8 bit

The analog output is galvanically isolated from the supply voltage (PELV) and other high-voltage terminals.

Control card, 24 V DC output:	
Terminal number	12, 13
Max. load	: 200 mA

The 24 V DC supply is galvanically isolated from the supply voltage (PELV), but has the same potential as the analog and digital inputs and outputs.

Relay outputs:	
Programmable relay outputs	2
Relay 01 Terminal number	1-3 (break), 1-2 (make)
Max. terminal load (AC-1) ¹⁾ on 1-3 (NC), 1-2 (NO) (Resistive load)	240 V AC, 2 A
Max. terminal load (AC-15) ¹⁾ (Inductive load @ cos ϕ 0.4)	240 V AC, 0.2 A
Max. terminal load (DC-1) ¹⁾ on 1-2 (NO), 1-3 (NC) (Resistive load)	60 V DC, 1 A
Max. terminal load (DC-13) ¹⁾ (Inductive load)	24 V DC, 0.1 A
Relay 02 Terminal number	4-6 (break), 4-5 (make)
Max. terminal load (AC-1) ¹⁾ on 4-5 (NO) (Resistive load)	240 V AC, 2 A

Max. terminal load (AC-15) ¹⁾ on 4-5 (NO) (Inductive load @ $\cos\phi$ 0.4)	240 V AC, 0.2 A
Max. terminal load (DC-1) ¹⁾ on 4-5 (NO) (Resistive load)	80 V DC, 2 A
Max. terminal load (DC-13) ¹⁾ on 4-5 (NO) (Inductive load)	24 V DC, 0.1 A
Max. terminal load (AC-1) ¹⁾ on 4-6 (NC) (Resistive load)	240 V AC, 2 A
Max. terminal load (AC-15) ¹⁾ on 4-6 (NC) (Inductive load @ $\cos\phi$ 0.4)	240 V AC, 0.2 A
Max. terminal load (DC-1) ¹⁾ on 4-6 (NC) (Resistive load)	50 V DC, 2 A
Max. terminal load (DC-13) ¹⁾ on 4-6 (NC) (Inductive load)	24 V DC, 0.1 A
Min. terminal load on 1-3 (NC), 1-2 (NO), 4-6 (NC), 4-5 (NO)	24 V DC 10 mA, 24 V AC 20 mA
Environment according to EN 60664-1	overvoltage category III/pollution degree 2

1) IEC 60947 part 4 and 5

The relay contacts are galvanically isolated from the rest of the circuit by reinforced isolation (PELV).

Control card, 10 V DC output:

Terminal number	50
Output voltage	10.5 V \pm 0.5 V
Max. load	25 mA

The 10 V DC supply is galvanically isolated from the supply voltage (PELV) and other high-voltage terminals.

Control characteristics:

Resolution of output frequency at 0-1000 Hz	: \pm 0.003 Hz
System response time (terminals 18, 19, 27, 29, 32, 33)	: \leq 2 ms
Speed control range (open-loop)	1:100 of synchronous speed
Speed accuracy (open-loop)	30-4000 rpm: Maximum error of \pm 8 rpm

All control characteristics are based on a 4-pole asynchronous motor

Surroundings:

Enclosure \leq enclosure type A	IP 20, IP 55
Enclosure \geq enclosure type A, B	IP 21, IP 55
Enclosure kit available \leq enclosure type A	IP 21/TYPE 1/IP 4X top
Vibration test	1.0 g
Max. relative humidity	5% - 95% (IEC 721-3-3); Class 3K3 (non-condensing) during operation
Aggressive environment (IEC 721-3-3), uncoated	class 3C2
Aggressive environment (IEC 721-3-3), coated	class 3C3
Test method according to IEC 60068-2-43 H2S (10 days)	
Ambient temperature	Max. 122°F [50°C] (max.113°F [45°C])

Derating for high ambient temperature, see section on special conditions

Minimum ambient temperature during full-scale operation	32° F [0 °C]
Minimum ambient temperature at reduced performance	14° F [-10° C]
Temperature during storage/transport	-13°-149°/158° F [-25° - +65/70 °C]
Maximum altitude above sea level without derating	3280 ft [1000 m]
Maximum altitude above sea level with derating	9842 ft [3000 m]

Derating for high altitude, see section on special conditions.

EMC standards, Emission	EN 61800-3, EN 61000-6-3/4, EN 55011, IEC 61800-3 EN 61800-3, EN 61000-6-1/2, EN 61000-4-2, EN 61000-4-3, EN 61000-4-4, EN 61000-4-5, EN
EMC standards, Immunity	61000-4-6

See section on Special conditions

Control card performance:

Scan interval : 5 ms

Control card, USB serial communication:

USB standard 1.1 (Full speed)
USB plug USB type B "device" plug

	<p>Connection to PC is carried out via a standard host/device USB cable.</p> <p>The USB connection is galvanically isolated from the supply voltage (PELV) and other high-voltage terminals.</p> <p>The USB connection is <u>not</u> galvanically isolated from protection ground. Use only isolated laptop/PC as connection to the USB connector on VLT AQUA Drive or an isolated USB cable/drive.</p>
--	---

9.1.3. Efficiency

Efficiency of VLT AQUA Drive Series (η_{VLT})

The load on the adjustable frequency drive has little effect on its efficiency. In general, the efficiency is the same at the rated motor frequency $f_{M,N}$, even if the motor supplies 100% of the rated shaft torque, or only 75% in case of part loads.

This also means that the efficiency of the adjustable frequency drive does not change even if other U/f characteristics are chosen.

However, the U/f characteristics influence the efficiency of the motor.

The efficiency declines a little when the switching frequency is set to a value greater than 5 kHz. The efficiency will also be slightly reduced if the line voltage is 480 V, or if the motor cable is longer than 98.43 ft. [30 m].

Efficiency of the motor (η_{MOTOR})

The efficiency of a motor connected to the adjustable frequency drive depends on magnetizing level. In general, the efficiency is just as good as with line operation. The efficiency of the motor depends on the type of motor.

In the range of 75-100% of the rated torque, the efficiency of the motor is practically constant, both when it is controlled by the adjustable frequency drive, and when it runs directly on line power.

In small motors, the influence from the U/f characteristic on efficiency is marginal. However, in motors from 15 hp [11 kW] and up, the advantages are significant.

In general, the switching frequency does not affect the efficiency of small motors. The efficiency of motors from 15 hp [11 kW] and up improves by 1-2%. This is because the sine shape of the motor current is almost perfect at high switching frequency.

Efficiency of the system (η_{SYSTEM})

To calculate the system efficiency, the efficiency of VLT AQUA Drive (η_{VLT}) is multiplied by the efficiency of the motor (η_{MOTOR}):

$$\eta_{\text{SYSTEM}} = \eta_{\text{VLT}} \times \eta_{\text{MOTOR}}$$

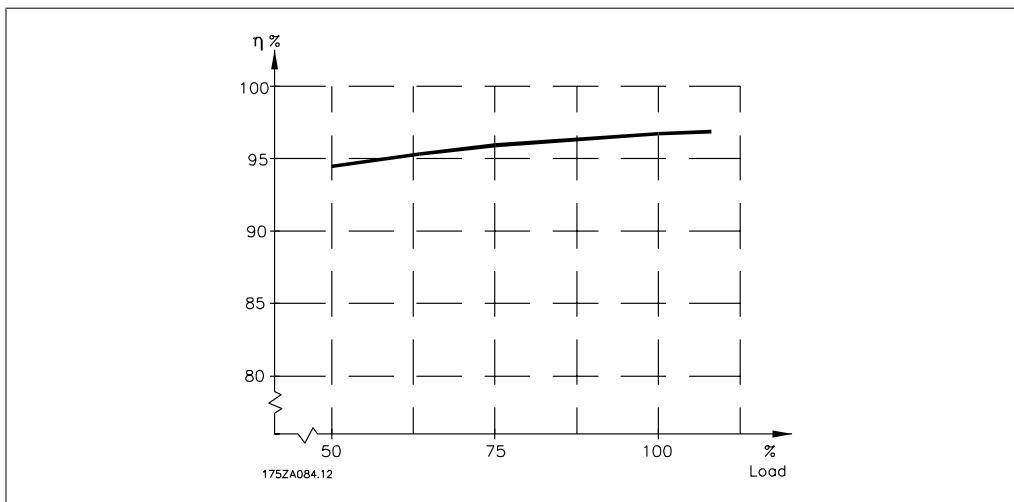

Based on the graph outlined above, it is possible to calculate the system efficiency at different speeds.

The acoustic noise from the adjustable frequency drive comes from three sources:

1. DC intermediate circuit coils.
2. Integrated fan.
3. RFI filter choke.

Typical values are measured at a distance of 3.28 ft. [1 m] from the unit:

Encapsulation	At reduced fan speed (50%) [dBA]	Full fan speed [dBA]
A2	51	60
A3	51	60
A5	-	54
B1	61	67
B2	58	70
C1	52	62
C2	55	65

When a transistor in the inverter bridge switches, the voltage across the motor increases by a du/dt ratio depending on:

- the motor cable (type, cross-section, length, shielded or unshielded)
- inductance

The natural induction causes an overshoot U_{PEAK} in the motor voltage before it stabilizes itself at a level depending on the voltage in the intermediate circuit. The rise time and the peak voltage

U_{PEAK} affect the service life of the motor. If the peak voltage is too high, motors without phase coil insulation are especially affected. If the motor cable is short (by a few yards), the rise time and peak voltage are lower.

If the motor cable is long (328 ft. [100 m]), the rise time and peak voltage are higher.

In motors without phase insulation paper or other insulation reinforcement suitable for operation with voltage supply (such as an adjustable frequency drive), fit a du/dt filter or a sine-wave filter on the output of the adjustable frequency drive.

9.2. Special Conditions

9.2.1. Purpose of derating

Derating must be taken into account when using the adjustable frequency drive at low air pressure (high elevations), at low speeds, with long motor cables, cables with a large cross-section or at high ambient temperature. The required action is described in this section.

9.2.2. Derating for Ambient Temperature

The average temperature ($T_{AMB, AVG}$) measured over 24 hours must be at least 9° F [5° C] lower than the maximum allowed ambient temperature ($T_{AMB, MAX}$).

If the adjustable frequency drive is operated at high ambient temperatures, the continuous output current should be decreased.

The derating depends on the switching pattern, which can be set to 60 PWM or SFAVM in parameter 14-00.

A enclosures

60 PWM (Pulse Width Modulation)

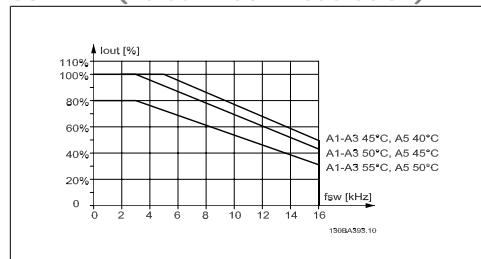

9.1: Derating of I_{out} for different $T_{AMB, MAX}$ for enclosure A, using 60 PWM

SFAVM - Stator Frequency Asynchron Vector Modulation

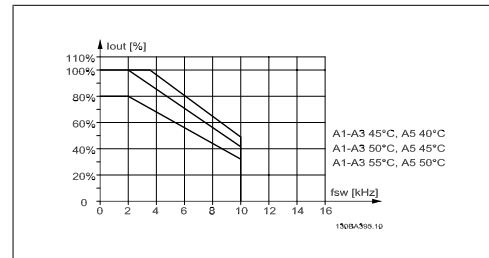

9.2: Derating of I_{out} for different $T_{AMB, MAX}$ for enclosure A, using SFAVM

In enclosure A, the length of the motor cable has a relatively high impact on the recommended derating. Therefore, the recommended derating for an application with max. 32 ft. [10 m] motor cable is also shown.

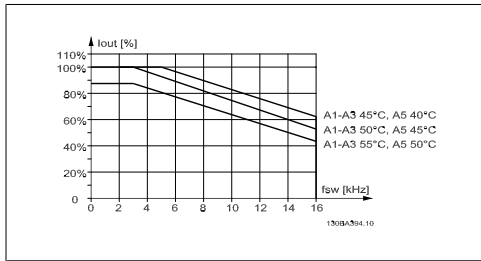

9.3: Derating of I_{out} for different $T_{AMB, MAX}$ for enclosure A, using 60 PWM and a maximum of 32 ft. [10 m] motor cable

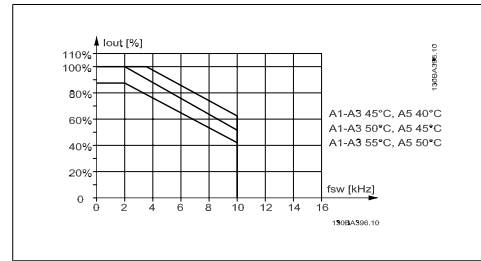

9.4: Derating of I_{out} for different $T_{AMB, MAX}$ for enclosure A, using SFAVM and a maximum of 32 ft. [10 m] motor cable

B enclosures

60 PWM (Pulse Width Modulation)

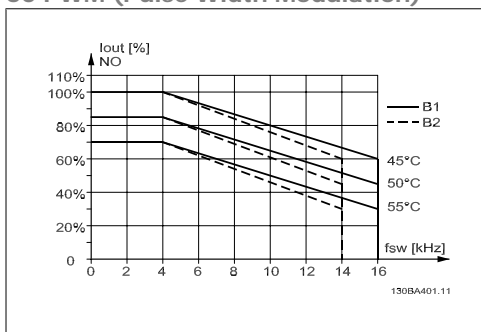

9.5: Derating of I_{out} for different $T_{AMB, MAX}$ for enclosure B, using 60 PWM in normal torque mode (110% over-torque)

SFAVM - Stator Frequency Asyncon Vector Modulation

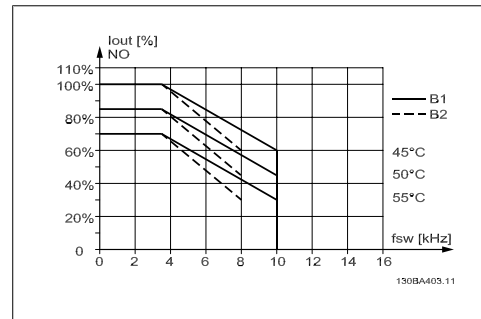

9.6: Derating of I_{out} for different $T_{AMB, MAX}$ for enclosure B, using SFAVM in normal torque mode (110% over-torque)

C enclosures

60 PWM (Pulse Width Modulation)

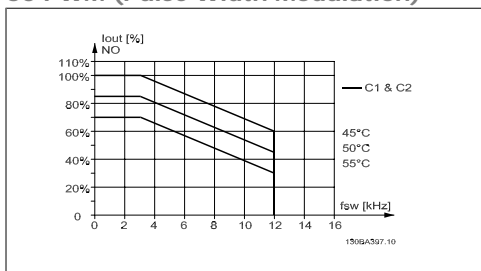

9.7: Derating of I_{out} for different $T_{AMB, MAX}$ for enclosure C, using 60 PWM in normal torque mode (110% over-torque)

SFAVM - Stator Frequency Asyncon Vector Modulation

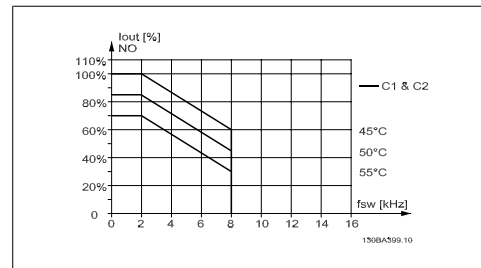

9.8: Derating of I_{out} for different $T_{AMB, MAX}$ for enclosure C, using SFAVM in normal torque mode (110% over-torque)

9.2.3. Derating for Low Air Pressure

The cooling capability of air is decreased at a lower air pressure.

At altitudes higher than 6,600 feet [2 km], please contact Danfoss Drives regarding PELV.

At an altitude lower than 3,280 ft [1,000 m], no derating is necessary; but at an altitude higher than 3,280 ft [1,000 m], the ambient temperature (T_{AMB}) or max. output current (I_{out}) should be derated in accordance with the diagram shown.

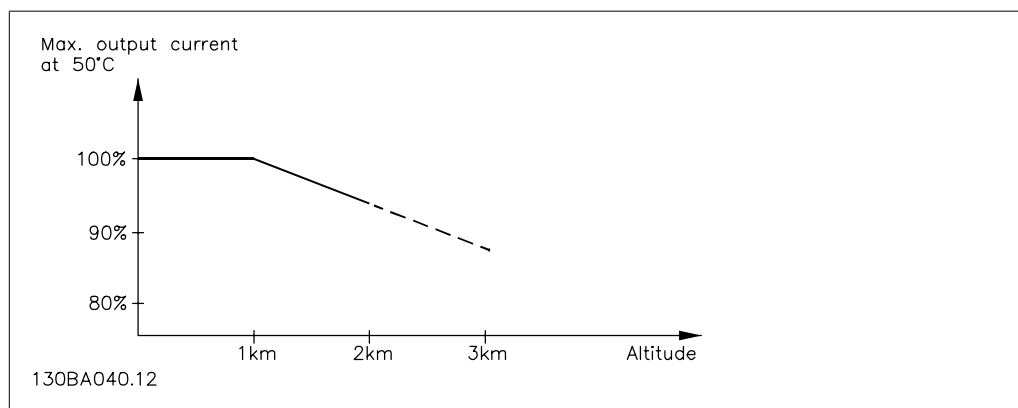

9.9: Derating of output current versus altitude at $T_{AMB, MAX}$. At altitudes higher than 6,600 feet [2 km], please contact Danfoss Drives regarding PELV.

An alternative is to lower the ambient temperature at high altitudes and thereby ensure 100% output current at high altitudes.

9.2.4. Derating for Running at Low Speed

When a motor is connected to an adjustable frequency drive, it is necessary to make sure that the cooling of the motor is adequate.

A problem may occur at low RPM values in constant torque applications. The motor fan may not be able to supply the required volume of air for cooling, which limits the torque that can be supported. Therefore, if the motor is to be run continuously at an RPM value lower than half of the rated value, the motor must be supplied with additional air-cooling (or a motor designed for this type of operation may be used).

An alternative is to reduce the load level of the motor by choosing a larger motor. However, the design of the adjustable frequency drive limits the motor size.

9.2.5. Derating for Installing Long Motor Cables or Cables with Larger Cross-Section

The maximum cable length for this adjustable frequency drive is 984 ft [300 m] for unshielded cable, and 492 ft [150 m] for shielded cable.

The adjustable frequency drive has been designed to work using a motor cable with a rated cross-section. If a cable with a larger cross-section is used, reduce the output current by 5% for every step the cross-section is increased.

(Increased cable cross-section leads to increased capacity to ground, and thus an increased ground leakage current).

9.2.6. Automatic adaptations to ensure performance

The adjustable frequency drive constantly checks for critical levels of internal temperature, load current, high voltage on the intermediate circuit and low motor speeds. As a response to a critical level, the adjustable frequency drive can adjust the switching frequency and/or change the switching pattern in order to ensure the performance of the drive. The capability to automatically reduce the output current extends the acceptable operating conditions even further.

Index

0

0-** Operation/display	88
------------------------------	----

1

1-** Load/motor	90
13-** Smart Logic	101
14-** Special Functions	102
15-** Fc Information	103
16-** Data Readouts	105
18-** Data Readouts 2	107

2

2-** Brakes	91
20-** Fc Closed-loop	108
21-** Ext. Closed-loop	109
22-** Application Functions	111
23-** Timed Actions	113
25-** Cascade Controller	114

3

3-** Reference / Ramps	92
------------------------------	----

4

4-** Limits / Warnings	93
------------------------------	----

5

5-** Digital In/out	94
---------------------------	----

6

6-** Analog In/out	96
--------------------------	----

8

8-** Comm. And Options	98
------------------------------	----

9

9-** Profibus	99
---------------------	----

A

Abbreviations And Standards	13
Acceleration Time	60
Access To Control Terminals	35
Acoustic Noise	140
Adjustable Frequency Drive	40
Ama	54
Analog Inputs	136
Analog Output	137
Automatic Adaptations To Ensure Performance	144
Automatic Motor Adaptation (ama)	41, 61

C

Cable Lengths And Cross-sections	135
--	-----

Changing A Group Of Numeric Data Values	84
Changing A Text Value	84
Changing Data	83
Changing Data Value	84
Coasting	48
Communication Option	124
Configuration Mode, 1-00	71
Control Cables	40
Control Cables	39
Control Card Performance	139
Control Card, +10 V Dc Output	138
Control Card, 24 V Dc Output	137
Control Card, Rs-485 Serial Communication	136
Control Card, Usb Serial Communication	139
Control Characteristics	138
Control Terminals	36
Cooling	143
D	
Dc Link	122
Default Settings	86
Default Settings	55, 85
Derating For Ambient Temperature	141
Derating For Installing Long Motor Cables Or Cables With Larger Cross-section	143
Derating For Low Air Pressure	142
Derating For Running At Low Speed	143
Digital Inputs:	136
Digital Output	136
Display Line 1.2 Small, 0-21	69
Display Line 1.3 Small, 0-22	69
Display Line 2 Large, 0-23	69
Display Line 3 Large, 0-24	69
Display Text 2, 0-38	70
Display Text 3, 0-39	70
Disposal Instructions	9
Dst/summertime Start, 0-76	71
E	
Efficiency	139
Efficient Parameter Set-up For Water Applications	58
Electrical Installation	39
Electronic Waste	9
Etr	122
F	
Function Relay, 5-40	73
Function Set-ups	62
Fuses	23
G	
General Warning	4
Glcp	54
Graphical Display	43
Grounding And It Line Power	25
H	
How To Connect A Pc To The Adjustable Frequency Drive	51
How To Operate The Graphical Lcp (glcp)	43

I	
Indexed Parameters	84
Initialization	55, 85
Installation At High Altitudes	5
Intermediate Circuit	122, 140
K	
Kty Sensor	123
L	
Language	59
Lcp	49, 54
Lcp 102	43
Leakage Current	6
Leds	43, 45
Line Connection For A2 And A3	27
Line Supply	127
Line Supply (L1, L2, L3)	135
Live Zero Timeout Function, 6-01	75
Live Zero Timeout Time, 6-00	75
M	
Main Menu	57
Main Menu Mode	47
Main Menu Mode	82
Main Reactance	61
Manual Initialization	86
Maximum Reference, 3-03	72
Mct 10	53
Mechanical Dimensions	20, 22
Motor Current	60
Motor Frequency, 1-23	59
Motor Nameplate	41
Motor Nominal Speed, 1-25	60
Motor Output	135
Motor Power [kw], 1-20	59
Motor Protection	135
Motor Speed High Limit [rpm], 4-13	61
Motor Speed Low Limit Rpm, 4-11	61
Motor Voltage	140
Motor Voltage	59
Motor Voltage, 1-22	59
N	
Nameplate Data	41
Nameplate Data.	41
Nlcp	49
Non-ul Compliance	24
O	
Output Performance (u, V, W)	135
P	
Parameter Options	86
Parameter Selection	83

Parameter Set-up	57
Pc Software Tools	52
Peak Voltage On Motor	140
Pid Integral Time, 20-94	82
Pid Normal/inverse Control, 20-81	81, 85
Pid Proportional Gain, 20-93	82
Pid Start Speed [rpm], 20-82	81
Preset Reference	72
Profibus Dp-v1	53
Protection	23
Protection And Features	134

Q

Quick Menu	46, 57, 58
Quick Menu Mode	46
Quick Transfer Of Parameter Settings When Using Gicp	54

R

Ramp 1 Ramp-down Time, 3-42	60
Ramp-up Time 1 Parameter, 3-41	60
Reference/feedback Unit, 20-12	79
Relay Outputs	137
Reset	48
Residual Current Device	6
Rise Time	140
Rs-485 Bus Connection	51

S

Safety Note	5
Safety Regulations	5
Serial Communication	139
Set Date And Time, 0-70	70
Setpoint 1, 20-21	81
Shielded/armored.	40
Sine-wave Filter	31
Stator Leakage Reactance	61
Status	46
Status Messages	43
Step-by-step	84
Surroundings	138
Switches S201, S202, And S801	40

T

Terminal 32 Digital Input, 5-14	73
Terminal 33 Digital Input, 5-15	73
Terminal 42 Output Min Scale, 6-51	78
Terminal 42 Output, 6-50	77
Terminal 53 High Voltage, 6-11	76
Terminal 53 Low Voltage, 6-10	76
Torque Characteristics	135
Type Code String	11
Type Code String (t/c).	11

U

Usb Connection.	36
-----------------	----

V

Voltage Level 136

W

Warning Against Unintended Start 5