

Contents

1. How to Read these Operating Instructions	3
Copyright, Limitation of Liability and Revision Rights	3
Approvals	3
Symbols	3
2. Safety	5
General Warning	6
Before Commencing Repair Work	6
Special conditions	6
Avoid unintended Start	7
Safe Stop of the Frequency Converter (optional)	7
IT Mains	8
3. Introduction	11
Type Code String	12
4. Mechanical installation	15
Before starting	15
How to install	16
5. Electrical installation	23
How to connect	23
Mains wiring overview	26
How to connect motor - foreword	31
Motor wiring overview	32
How to Test Motor and Direction of Rotation.	37
6. Application Examples	45
Closed Loop Wiring	45
Submersible Pump Application	46
7. How to operate the frequency converter	49
Ways of Operation	49
How to operate graphical LCP (GLCP)	49
How to operate numeric LCP (NLCP)	54
Tips and tricks	57
8. How to programme the frequency converter	61
How to programme	61
Q1 My Personal Menu	62
Q2 Quick Setup	62
Q5 Changes Made	65

Q6 Loggings	65
Common Used Parameters - Explanations	67
Main Menu	67
Parameter Options	99
How to Read the Parameter Tabela	99
Operation/Display 0-**	100
Load/Motor 1-**	102
Brakes 2-**	103
Reference / Ramps 3-**	104
Limits / Warnings 4-**	105
Digital In/Out 5-**	106
Analog In/Out 6-**	107
Comm. and Options 8-**	108
Profibus 9-**	109
CAN Fieldbus 10-**	110
Smart Logic 13-**	111
Special Functions 14-**	112
FC Information 15-**	113
Data Readouts 16-**	115
Data Readouts 2 18-**	117
FC Closed Loop 20-**	118
Ext. Closed Loop 21-**	119
Application Functions 22-**	120
Timed Actions 23-**	122
Cascade Controller 25-**	123
Analog I/O Option MCB 109 26-**	125
Cascade CTL Option 27-**	126
Water Application Functions 29-**	127
Bypass Option 31-**	128
9. Troubleshooting	129
Warning/Alarm list	131
10. Specifications	135
General Specifications	135
Special Conditions	150
Index	155

1. How to Read these Operating Instructions

1.1.1. Copyright, Limitation of Liability and Revision Rights

This publication contains information proprietary to . By accepting and using this manual the user agrees that the information contained herein will be used solely for operating equipment from or equipment from other vendors provided that such equipment is intended for communication with equipment over a serial communication link. This publication is protected under the Copyright laws of Denmark and most other countries.

does not warrant that a software program produced according to the guidelines provided in this manual will function properly in every physical, hardware or software environment.

Although has tested and reviewed the documentation within this manual, makes no warranty or representation, neither expressed nor implied, with respect to this documentation, including its quality, performance, or fitness for a particular purpose.

In no event shall be liable for direct, indirect, special, incidental, or consequential damages arising out of the use, or the inability to use information contained in this manual, even if advised of the possibility of such damages. In particular, is not responsible for any costs, including but not limited to those incurred as a result of lost profits or revenue, loss or damage of equipment, loss of computer programs, loss of data, the costs to substitute these, or any claims by third parties.

reserves the right to revise this publication at any time and to make changes to its contents without prior notice or any obligation to notify former or present users of such revisions or changes.

These Operating Instructions will introduce all aspects of your VLT AQUA Drive.

Available literature for VLT AQUA Drive:

- Operating Instructions MG.20.MX.YY provide the necessary information for getting the drive up and running.
- Design Guide MG.20.NX.YY entails technical information about the drive design and customer applications.
- Programming Guide MG.20.OX.YY provides information on how to programme and includes complete parameter descriptions.

X = Revision number

YY = Language code

Danfoss Drives technical literature is also available online at www.danfoss.com/BusinessAreas/DrivesSolutions/Documentations/Technical+Documentation.

1.1.2. Approvals



1.1.3. Symbols

Symbols used in these Operating Instructions.



1



Indicates a general warning.



Indicates a high-voltage warning.

*

Indicates default setting

2. Safety

2.1.1. Safety note



The voltage of the frequency converter is dangerous whenever connected to mains. Incorrect installation of the motor, frequency converter or fieldbus may cause damage to the equipment, serious personal injury or death. Consequently, the instructions in this manual, as well as national and local rules and safety regulations, must be complied with.

Safety Regulations

1. The frequency converter must be disconnected from mains if repair work is to be carried out. Check that the mains supply has been disconnected and that the necessary time has passed before removing motor and mains plugs.
2. The [STOP/RESET] key on the control panel of the frequency converter does not disconnect the equipment from mains and is thus not to be used as a safety switch.
3. Correct protective earthing of the equipment must be established, the user must be protected against supply voltage, and the motor must be protected against overload in accordance with applicable national and local regulations.
4. The earth leakage currents are higher than 3.5 mA.
5. Protection against motor overload is set by par. 1-90 *Motor Thermal Protection*. If this function is desired, set par. 1-90 to data value [ETR trip] (default value) or data value [ETR warning]. Note: The function is initialised at 1.16 x rated motor current and rated motor frequency. For the North American market: The ETR functions provide class 20 motor overload protection in accordance with NEC.
6. Do not remove the plugs for the motor and mains supply while the frequency converter is connected to mains. Check that the mains supply has been disconnected and that the necessary time has passed before removing motor and mains plugs.
7. Please note that the frequency converter has voltage inputs other than L1, L2 and L3, when load sharing (linking of DC intermediate circuit) and external 24 V DC have been installed. Check that all voltage inputs have been disconnected and that the necessary time has passed before commencing repair work.

Installation at High Altitudes



By altitudes above 2 km, please contact Danfoss regarding PELV.

Warning against Unintended Start

1. The motor can be brought to a stop by means of digital commands, bus commands, references or a local stop, while the frequency converter is connected to mains. If personal safety considerations make it necessary to ensure that no unintended start occurs, these stop functions are not sufficient.
2. While parameters are being changed, the motor may start. Consequently, the stop key [STOP/RESET] must always be activated; following which data can be modified.
3. A motor that has been stopped may start if faults occur in the electronics of the frequency converter, or if a temporary overload or a fault in the supply mains or the motor connection ceases.



Warning:

Touching the electrical parts may be fatal - even after the equipment has been disconnected from mains.

Also make sure that other voltage inputs have been disconnected, such as external 24 V DC, load sharing (linkage of DC intermediate circuit), as well as the motor connection for kinetic back up.

2.1.2. General Warning



Warning:

Touching the electrical parts may be fatal - even after the equipment has been disconnected from mains.

Also make sure that other voltage inputs have been disconnected, (linkage of DC intermediate circuit), as well as the motor connection for kinetic back-up.

Before touching any potentially live parts of the VLT AQUA Drive FC 200, wait at least as follows:

200 - 240 V, 0.25 - 3.7 kW: wait at least 4 minutes.

200 - 240 V, 5.5 - 45 kW: wait at least 15 minutes.

380 - 480 V, 0.37 - 7.5 kW: wait at least 4 minutes.

380 - 480 V, 11 - 90 kW, wait at least 15 minutes.

525 - 600 V, 1.1 - 7.5 kW, wait at least 4 minutes.

525 - 600 V, 110 - 250 kW, wait at least 20 minutes.

525 - 600 V, 315 - 560 kW, wait at least 30 minutes.

Shorter time is allowed only if indicated on the nameplate for the specific unit.



Leakage Current

The earth leakage current from the VLT AQUA Drive FC 200 exceeds 3.5 mA. According to IEC 61800-5-1 a reinforced Protective Earth connection must be ensured by means of: a min. 10mm² Cu or 16mm² Al PE-wire or an additional PE wire - with the same cable cross section as the Mains wiring - must be terminated separately.

Residual Current Device

This product can cause a D.C. current in the protective conductor. Where a residual current device (RCD) is used for extra protection, only an RCD of Type B (time delayed) shall be used on the supply side of this product. See also RCD Application Note MN.90.GX.02.

Protective earthing of the VLT AQUA Drive FC 200 and the use of RCD's must always follow national and local regulations.

2.1.3. Before Commencing Repair Work

1. Disconnect the frequency converter from mains
2. Disconnect DC bus terminals 88 and 89
3. Wait at least the time mentioned in section 2.1.2
4. Remove motor cable

2.1.4. Special conditions

Electrical ratings:

The rating indicated on the nameplate of the frequency converter is based on a typical 3-phase mains power supply, within the specified voltage, current and temperature range, which is expected to be used in most applications.

The frequency converters also support other special applications, which affect the electrical ratings of the frequency converter. Special conditions which affect the electrical ratings might be:

- Single phase applications
- High temperature applications which require derating of the electrical ratings
- Marine applications with more severe environmental conditions.

Consult the relevant clauses in these instructions and in the **VLT® AQUA Drive Design Guide** for information about the electrical ratings.

Installation requirements:

The overall electrical safety of the frequency converter requires special installation considerations regarding:

- Fuses and circuit breakers for over-current and short-circuit protection
- Selection of power cables (mains, motor, brake, loadsharing and relay)
- Grid configuration (IT, TN, grounded leg, etc.)
- Safety of low-voltage ports (PELV conditions).

Consult the relevant clauses in these instructions and in the **VLT® AQUA Drive Design Guide** for information about the installation requirements.

2.1.5. Caution

The frequency converter DC link capacitors remain charged after power has been disconnected. To avoid an electrical shock hazard, disconnect the frequency converter from the mains before carrying out maintenance. Wait at least as follows before doing service on the frequency converter:



Voltage	Min. Waiting Time			
	4 min.	15 min.	20 min.	30 min.
200 - 240 V	0.25 - 3.7 kW	5.5 - 45 kW		
380 - 480 V	0.37 - 7.5 kW	11 - 90 kW	110 - 250 kW	315 - 450 kW
525-600 V	0.75 kW - 7.5 kW		110 - 250 kW	315 - 560 kW
525-690 V			45 - 400 kW	450 - 630 kW

Be aware that there may be high voltage on the DC link even when the LEDs are turned off.

2.1.6. Avoid unintended Start

While the frequency converter is connected to mains, the motor can be started/stopped using digital commands, bus commands, references or via the Local Control Panel.

- Disconnect the frequency converter from mains whenever personal safety considerations make it necessary to avoid unintended start.
- To avoid unintended start, always activate the [OFF] key before changing parameters.
- Unless terminal 37 is turned off, an electronic fault, temporary overload, a fault in the mains supply, or lost motor connection may cause a stopped motor to start.

2.1.7. Safe Stop of the Frequency Converter (optional)

For versions fitted with a Safe Stop terminal 37 input, the frequency converter can perform the safety function *Safe Torque Off* (As defined by draft CD IEC 61800-5-2) or *Stop Category 0* (as defined in EN 60204-1).

It is designed and approved suitable for the requirements of Safety Category 3 in EN 954-1. This functionality is called Safe Stop. Prior to integration and use of Safe Stop in an installation, a thorough risk analysis on the installation must be carried out in order to determine whether the Safe Stop functionality and safety category are appropriate and sufficient. In order to install and use the Safe Stop function in accordance with the requirements of Safety Category 3 in EN 954-1, the related information and instructions of the VLT AQUA Drive Design Guide MG.20.NX.YY must be followed! The information and instructions of the Operating Instructions are not sufficient for a correct and safe use of the Safe Stop functionality!

2



2.1.8. IT Mains

IT Mains
Do not connect 400 V frequency converters with RFI-filters to mains supplies with a voltage between phase and earth of more than 440 V.
For IT mains and delta earth (grounded leg), mains voltage may exceed 440 V between phase and earth.

Par. 14-50 *RFI 1* can be used to disconnect the internal RFI capacitors from the RFI filter to ground. If this is done it will reduce the RFI performance to A2 level.

2.1.9. Software Version and Approvals: VLT AQUA Drive

VLT AQUA Drive
Operating Instructions
Software version: 1.05

This Operating Instructions can be used for all VLT AQUA Drive frequency converters with software version 1.05.
The software version number can be seen from parameter 15-43.

2.1.10. Disposal Instruction



Equipment containing electrical components must not be disposed of together with domestic waste. It must be separately collected with electrical and electronic waste according to local and currently valid legislation.

3. Introduction

3.1. Introduction

3.1.1. Frequency Converter Identification

Below is an example of an identification label. This label is situated on the frequency converter and shows the type and options fitted to the unit. See table 2.1 for details of how to read the type code string (T/C).



Illustration 3.1: This example shows an identification label for VLT AQUA Drive.

Please have T/C (type code) number and serial number ready before contacting Danfoss.

3.1.2. Type Code String

1	2	3	4	5	6	7	8	9	10	11	12	13	14	15	16	17	18	19	20	21	22	23	24	25	26	27	28	29	30	31	32	33	34	35	36	37	38	39
FC	-	2	0	2	P					T						H						X	X	S	X	X	X	X	A	B	C						D	
130BA484.10																																						

3

Description	Pos	Possible choice
Product group & VLT Series	1-6	FC 202
Power rating	8-10	0.25 - 630 kW
Number of phases	11	Three phases (T)
Mains voltage	11-12	T 2: 200-240 VAC T 4: 380-480 VAC T 6: 525-600 VAC T 7:
Enclosure	13-15	E20: IP20 E21: IP 21/NEMA Type 1 E55: IP 55/NEMA Type 12 E2M: IP21/NEMA Type 1 w/mains shield E5M: IP 55/NEMA Type 12 w/mains shield E66: IP66 P21: IP21/NEMA Type 1 w/backplate P55: IP55/NEMA Type 12 w/backplate
RFI filter	16-17	H1: RFI filter class A1/B H2: RFI filter class A2 H3: RFI filter class A1/B (reduced cable length) H4: RFI filter class A2/A1
Brake	18	X: No brake chopper included B: Brake chopper included T: Safe Stop U: Safe + brake
Display	19	G: Graphical Local Control Panel (GLCP) N: Numeric Local Control Panel (NLCP) X: No Local Control Panel
Coating PCB	20	X: No coated PCB C: Coated PCB
Mains option	21	X: No Mains disconnect switch 1: With Mains disconnect switch
Adaptation	22	Reserved
Adaptation	23	Reserved
Software release	24-27	Actual software
Software language	28	
A options	29-30	AX: No options A0: MCA 101 Profibus DP V1 A4: MCA 104 DeviceNet
B options	31-32	BX: No option BK: MCB 101 General purpose I/O option BP: MCB 105 Relay option BO: MCB 109 Analog I/O option
C0 options MCO	33-34	CX: No options
C1 options	35	X: No options
C option software	36-37	XX: Standard software
D options	38-39	DX: No option D0: DC back-up

Table 3.1: Type code description.

The various options are described further in the VLT AQUA Drive Design Guide.

3.1.3. Abbreviations and Standards

Abbreviations:	Terms:	SI-units:	I-P units:
	Acceleration	m/s ²	ft/s ²
AWG	American wire gauge		
Auto Tune	Automatic Motor Tuning		
°C	Celsius		
	Current	A	Amp
I _{LIM}	Current limit		
	Energy	J = N·m	ft-lb, Btu
°F	Fahrenheit		
FC	Frequency Converter		
	Frequency	Hz	Hz
kHz	Kilohertz		
LCP	Local Control Panel		
mA	Milliampere		
ms	Millisecond		
min	Minute		
MCT	Motion Control Tool		
M-TYPE	Motor Type Dependent		
Nm	Newton Metres		in-lbs
I _{M,N}	Nominal motor current		
f _{M,N}	Nominal motor frequency		
P _{M,N}	Nominal motor power		
U _{M,N}	Nominal motor voltage		
par.	Parameter		
PELV	Protective Extra Low Voltage		
	Power	W	Btu/hr, hp
	Pressure	Pa = N/m ²	psi, psf, ft of water
I _{INV}	Rated Inverter Output Current		
RPM	Revolutions Per Minute		
SR	Size Related		
	Temperature	°C	°F
	Time	s	s,hr
T _{LIM}	Torque limit		
	Voltage	V	V

Table 3.2: Abbreviation and Standards table .

4. Mechanical installation

4.1. Before starting

4.1.1. Checklist

When unpacking the frequency converter, ensure that the unit is undamaged and complete. Use the following table to identify the packaging:

Enclosure type:	A2 (IP 20/ 21)	A3 (IP 20/21)	A5 (IP 55/ 66)	B1/B3 (IP20/ 21/ 55/ 66)	B2/B4 (IP20/ 21/ 55/66)	C1/C3 (IP20/21/ 55/66)	C2/C4 (IP20/21/ 55/66)
Unit size:							
200-240 V	0.25-3.0 kW	3.7 kW	0.25-3.7 kW	5.5-7.5 kW	11-15 kW	18.5 - 30 kW	37 - 45 kW
380-480 V	0.37-4.0 kW	5.5-7.5 kW	0.37-7.5 kW	11-18.5 kW	22-37 kW	37 - 55 kW	75 - 90 kW
525-600 V	0.75-4.0 kW	5.5-7.5 kW	0.75-7.5 kW	11-18.5 kW	22-37 kW	45-55 kW	75 - 90 kW

Table 4.1: Unpacking table

Please note that a selection of screwdrivers (phillips or cross-thread screwdriver and torx), a side-cutter, drill and knife is also recommended to have handy for unpacking and mounting the frequency converter. The packaging for these enclosures contains, as shown: Accessories bag(s), documentation and the unit. Depending on options fitted there may be one or two bags and one or more booklets.

4.2. How to install

4.2.1. Checklist

Please use the following table to follow mounting instructions

4







Enclosure:	A2 (IP 20/ 21)	A3 (IP 20/ 21)	A5 (IP 55/ 66)	B1 /B3 (IP 20/ 21/ 55/66)	B2 /B4 (IP20/ 21/ 55/66)	C1/C3 (IP20/21/ 55/66)	C2/C4 (IP20/21/ 55/66)
							
Unit size:							
200-240 V	0.25-3.0 kW	3.7 kW	0.25-3.7 kW	5.5-11 kW	15 kW	18.5-30 kW	37-45 kW
380-480 V	0.37-4.0 kW	5.5-7.5 kW	0.37-7.5 kW	11-18.5 kW	22-30 kW	37-55 kW	75-90 kW
525-600 V	0.75-4.0 kW	5.5-7.5 kW	0.75-7.5 kW	11-18.5 kW	22-37 kW	45-55 kW	75-90 kW

Table 4.2: Mounting table.

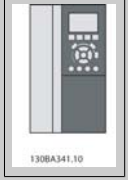
The frequency converter can be mounted side by side for all IP rating units and requires 100 mm free space above and below for cooling. With regard to ambient temperature ratings, please see Special Conditions.

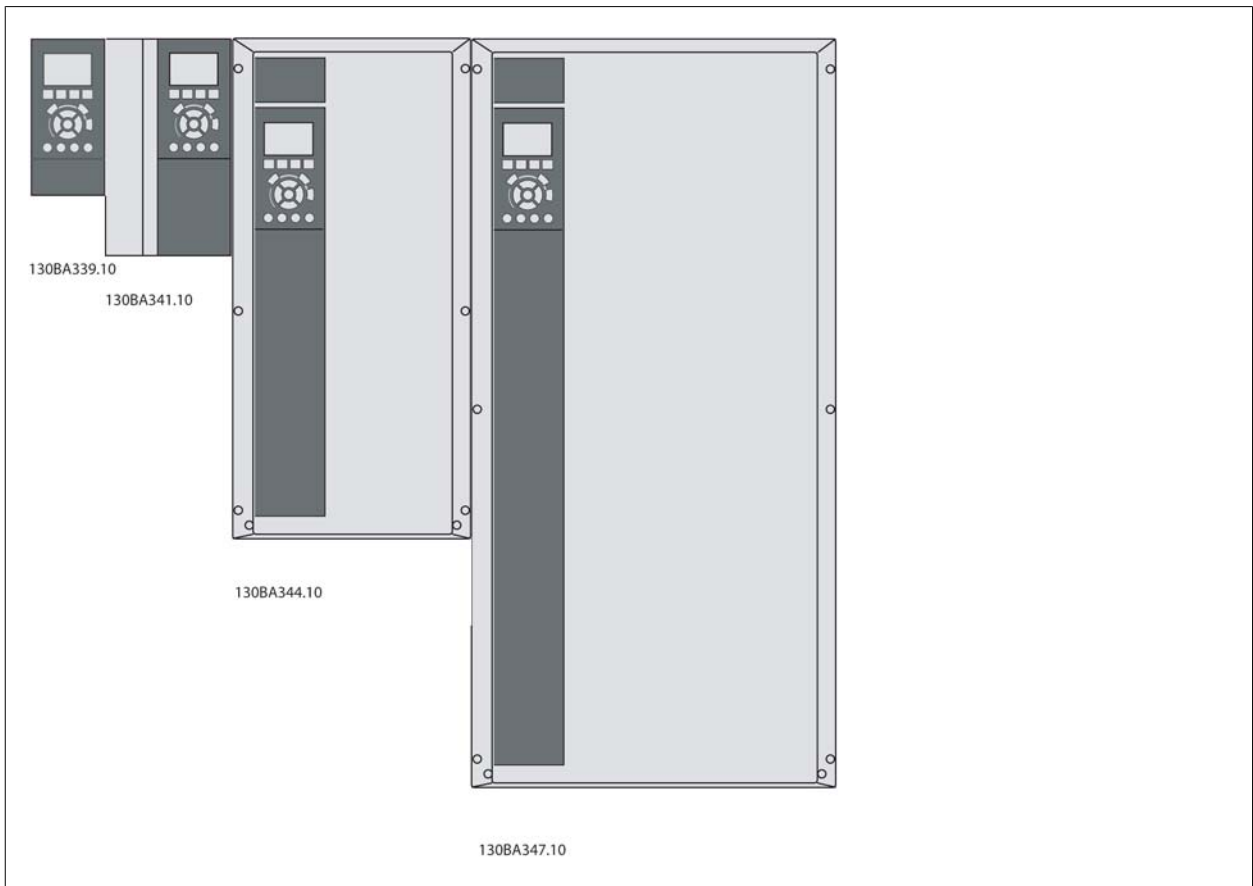

Illustration 4.1: Side by side mounting of all frame sizes.

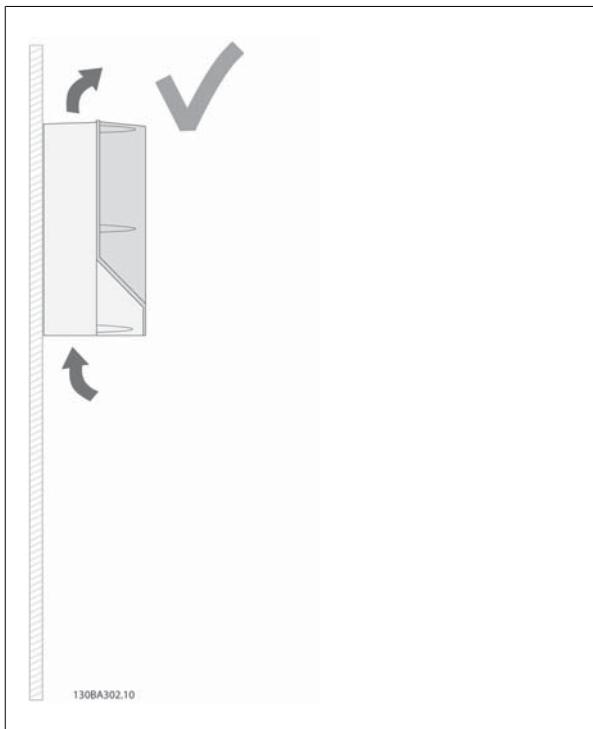

Illustration 4.2: This is the correct way to mount the unit.

4

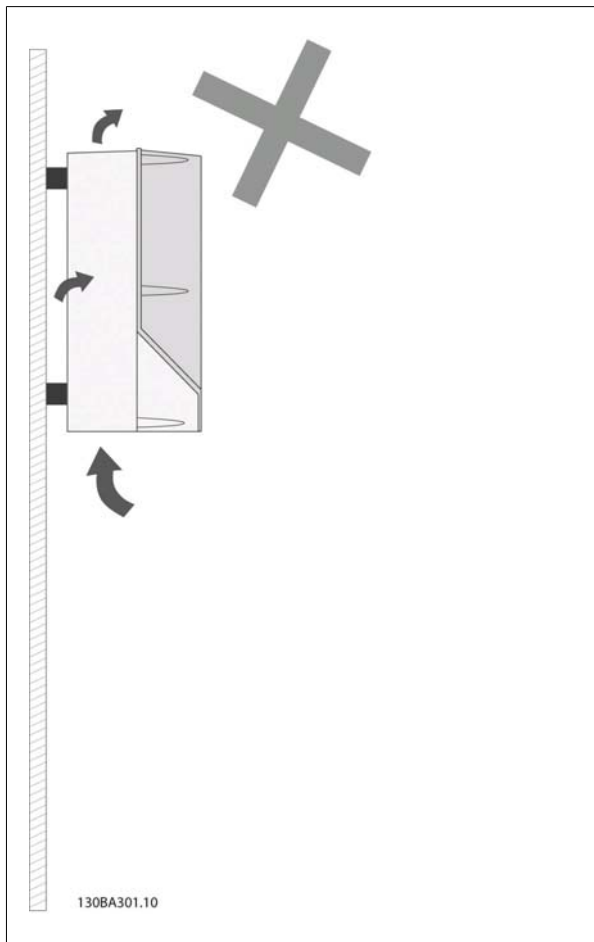

Illustration 4.3: Other than A2 and A3 enclosures do not mount units as shown without back plate. Cooling will be insufficient and service life can be drastically shortened.

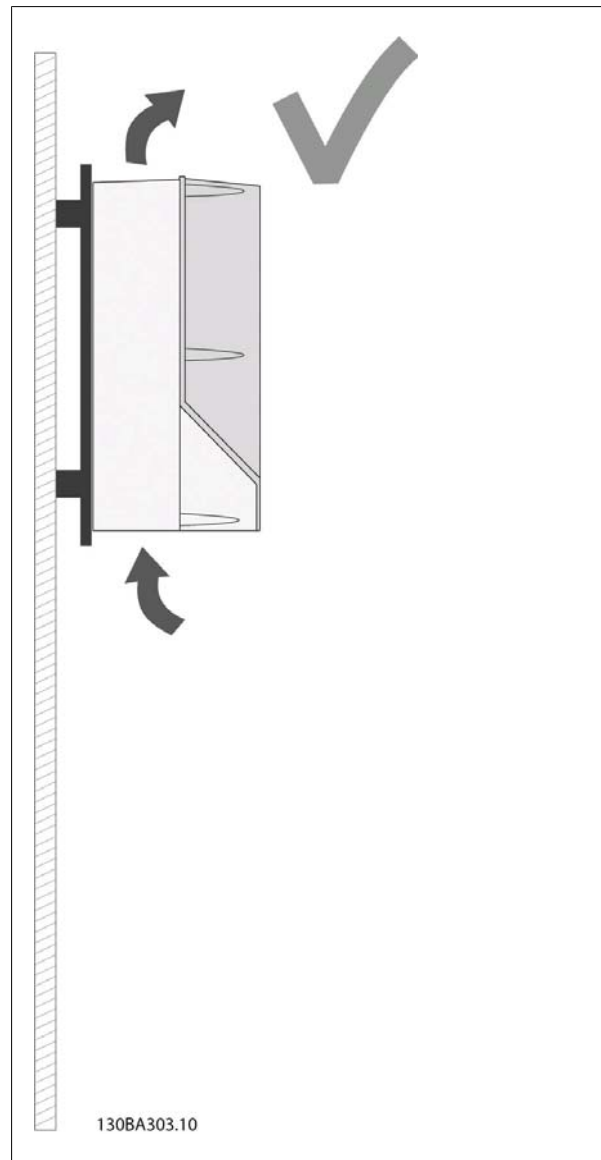

Illustration 4.4: If the unit must be mounted a small distance from the wall please order the back plate with the unit (see Ordering type code position 14-15). A2 and A3 units have back-plate as standard.

4.2.2. Mounting A2 and A3.

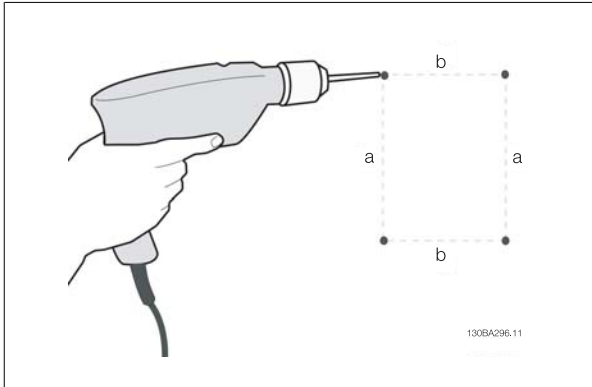

Illustration 4.5: Drilling of holes

Step 1: Drill according to the dimensions in the following table.

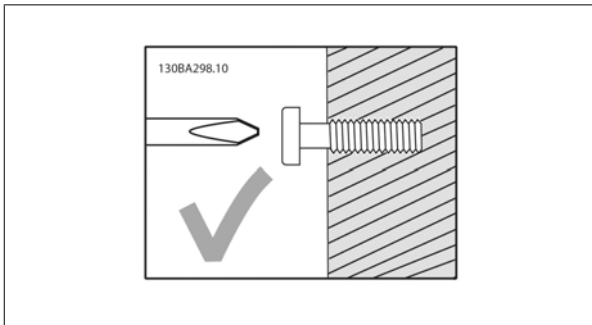

Illustration 4.6: Correct mounting of screws.

Step 2A: This way it is easy to hang the unit on the screws.

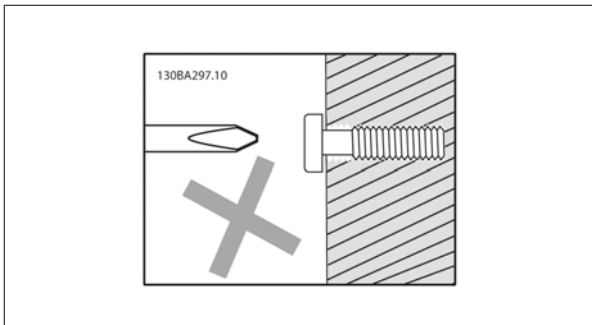

Illustration 4.7: Wrong mounting of screws.

Step 2B: Do not tighten screws completely.

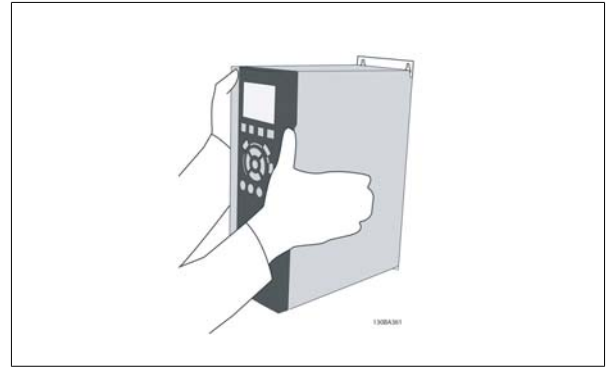

Illustration 4.8: Mounting of unit.

Step 3: Lift the unit onto the screws.

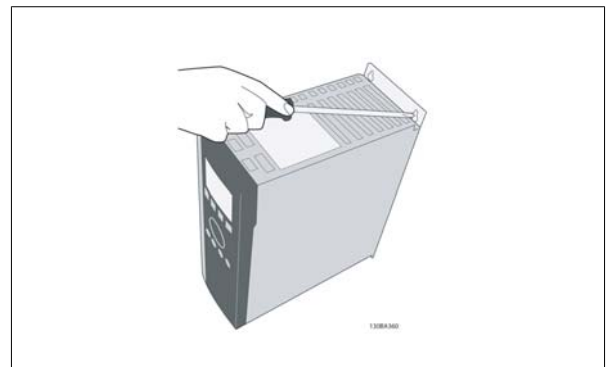
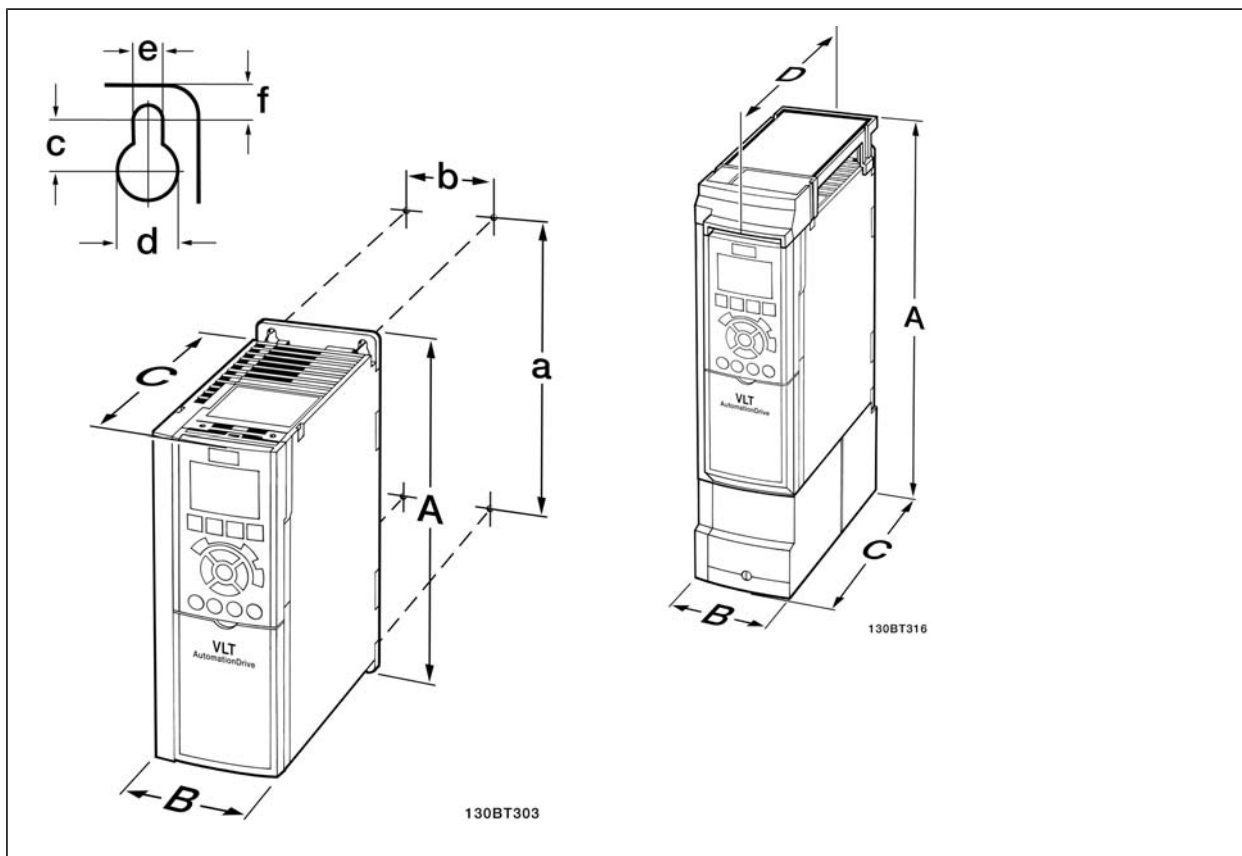

Illustration 4.9: Tightening of screws

Step 4: Tighten screws completely.

4



Mechanical dimensions					
Voltage		Frame size A2		Frame size A3	
200-240 V		0.25-3.0 kW		3.7 kW	
Voltage		0.37-4.0 kW		5.5-7.5 kW	
380-480 V					
Encapsulation		IP20	IP21/Type 1	IP20	IP21/Type 1
Height					
Height of back plate	A	268 mm	375 mm	268 mm	375 mm
Distance between mounting holes	a	257 mm	350 mm	257 mm	350 mm
Width					
Width of back plate	B	90 mm	90 mm	130 mm	130 mm
Distance between mounting holes	b	70 mm	70 mm	110 mm	110 mm
Depth					
Depth without option A/B	C	205 mm	205 mm	205 mm	205 mm
With option A/B	C	220 mm	220 mm	220 mm	220 mm
Without option A/B	D	207 mm	207 mm	207 mm	207 mm
With option A/B	D	222 mm	222 mm	222 mm	222 mm
Screw holes					
	c	8.0 mm	8.0 mm	8.0 mm	8.0 mm
	d	ø11 mm	ø11 mm	ø11 mm	ø11 mm
	e	ø5.5 mm	ø5.5 mm	ø5.5 mm	ø5.5 mm
	f	9 mm	9 mm	9 mm	9 mm
Maximum weight		4.9 kg	5.3 kg	6.6 kg	7.0 kg

Table 4.3: A2 and A3 mechanical dimensions

NB!
Option A/B are serial communication and I/O options, which when fitted increase the depth on some enclosure sizes.

4.2.3. Mounting A5, B1, B2, B3, B4, C1, C2, C3 and C4.

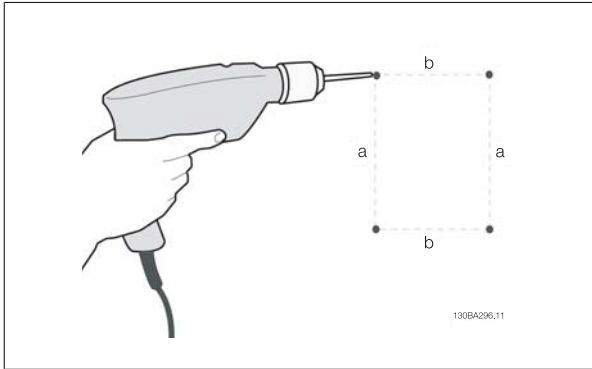

Illustration 4.10: Drilling holes.

Step 1: Drill according to the dimensions in the following table.

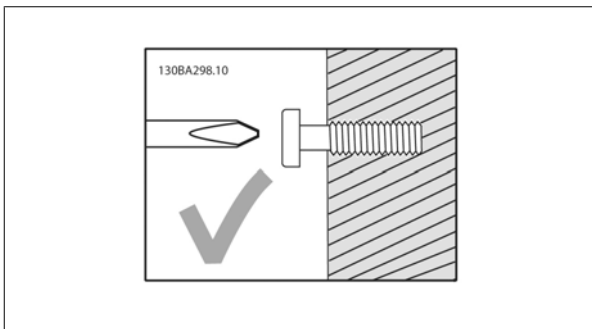

Illustration 4.11: Correct mounting of screws

Step 2A: This way it is easy to hang the unit on the screws.

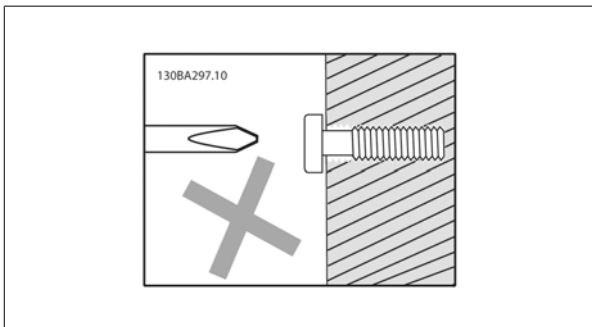

Illustration 4.12: Wrong mounting of screws

Step 2B: Do not tighten screws completely.

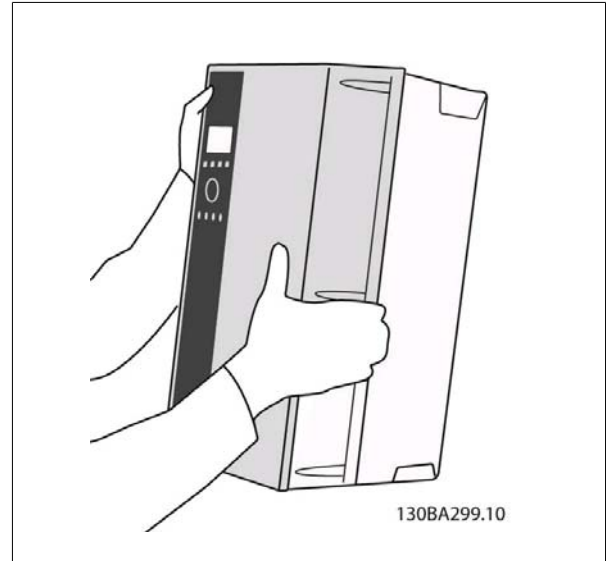

Illustration 4.13: Mounting of unit.

Step 3: Lift the unit onto the screws.

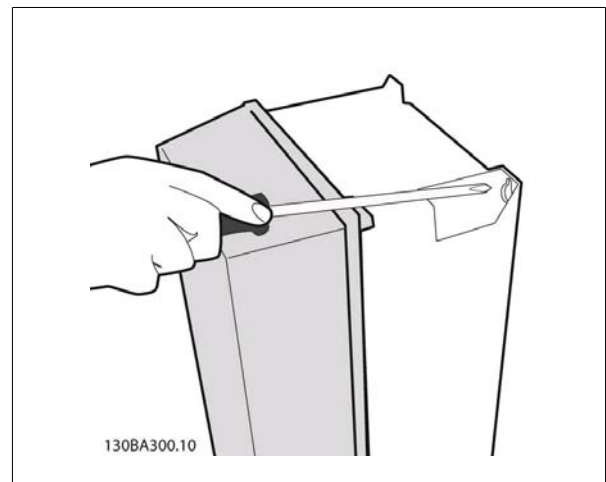
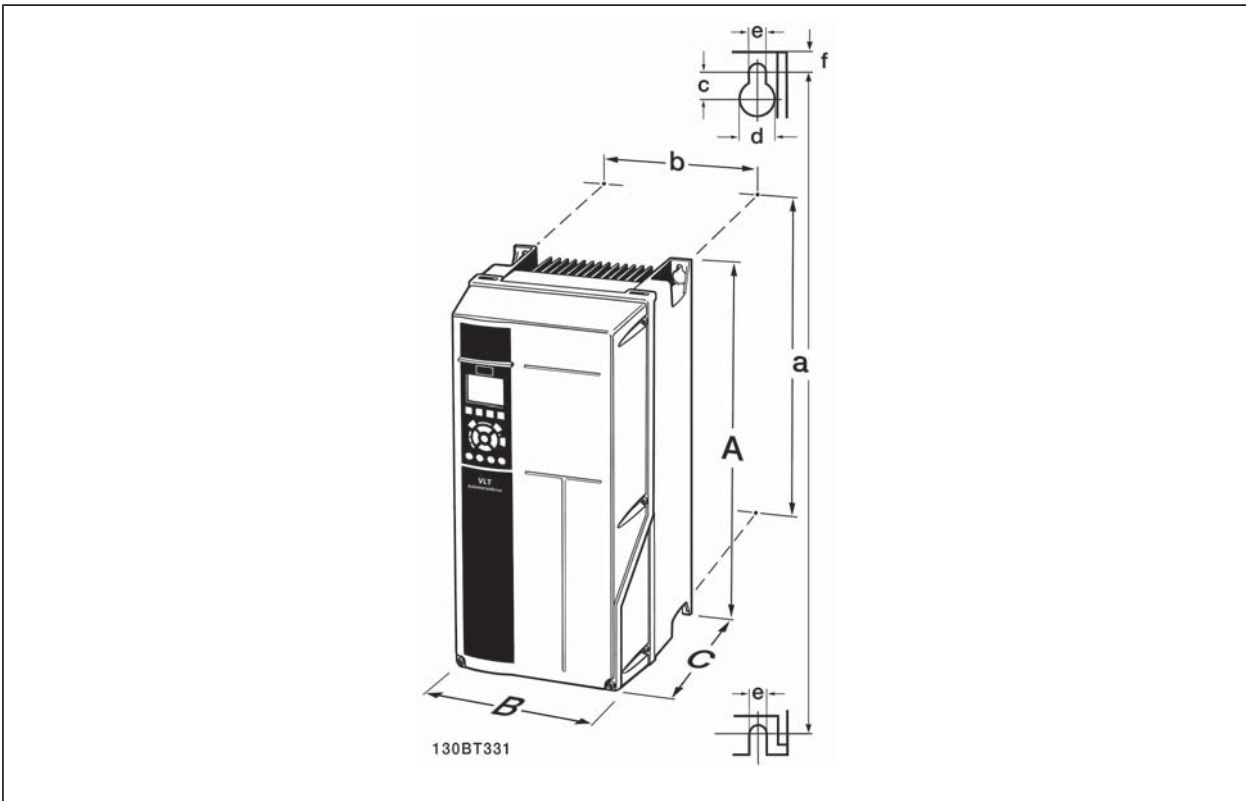

Illustration 4.14: Tightening of screws

Step 4: Tighten screws completely.

4



Mechanical dimensions										
Voltage: 200-240 V 380-480 V	Frame size A5 0.25-3.7 kW 0.37-7.5 kW	Frame size B1 5.5-11 kW 11-18.5 kW	Frame size B2 15 kW 22-30 kW	Frame size B3 5.5-11 kW 11-18.5 kW	Frame size B4 15-18.5 kW 22-37 kW	Frame size C1 18.5-30 kW 37-55 kW	Frame size C2 30-45 kW 75-90 kW	Frame size C3 22-30 kW 45-55 kW	Frame size C4 37-45 kW 75-90 kW	
Encapsula- tion	IP55/66	IP21/55/66	IP21/55/66	IP20	IP20	IP21/55/66	IP21/55/66	IP20	IP20	
Height¹⁾										
Height	A	420 mm	480 mm	650 mm	399 mm	520 mm	680 mm	770 mm	550 mm	660 mm
Distance be- tween mounting holes	a	402 mm	454 mm	624 mm	380 mm	495 mm	648 mm	739 mm	521 mm	631 mm
Width¹⁾										
Width	B	242 mm	242 mm	242 mm	165 mm	230 mm	308 mm	370 mm	380 mm	370 mm
Distance be- tween mounting holes	b	215 mm	210 mm	210 mm	140 mm	200 mm	272 mm	334 mm	270 mm	330 mm
Depth										
Depth	C	195 mm	260 mm	260 mm	232 mm	239 mm	310 mm	335 mm	330 mm	330 mm
Screw holes										
c	8.25 mm	12 mm	12 mm	8 mm	-	12.5 mm	12.5 mm	-	-	
d	ø12 mm	ø19 mm	ø19 mm	12 mm	-	ø19 mm	ø19 mm	-	-	
e	ø6.5 mm	ø6.5 mm	ø6.5 mm	ø6.8 mm	ø8.5 mm	ø9	ø9	ø8.5	ø8.5	
f	9 mm	9 mm	9 mm	7.9 mm	15 mm	9.8	9.8	17	17	
Max. weight		13.5 / 14.2	23 kg	27 kg	12 kg	23.5 kg	45 kg	65 kg	35 kg	50 kg

Table 4.4: A5, B1, B2, B3, B4, C3 and C4 mechanical dimensions.

1) The dimensions state the maximum height, width and depth needed for mounting the frequency converter, when the top cover is mounted.

5. Electrical installation

5.1. How to connect

5.1.1. Cables General



NB!

Always comply with national and local regulations on cable cross-sections.

Details of terminal tightening torques.

Enclosure	Power (kW)			Torque (Nm)					
	200-240 V	380-480 V	525-600 V	Line	Motor	DC connection	Brake	Earth	Relay
A2	0.25 - 3.0	0.37 - 4.0	0.75 - 4.0	1.8	1.8	1.8	1.8	3	0.6
A3	3.7	5.5 - 7.5	5.5 - 7.5	1.8	1.8	1.8	1.8	3	0.6
A5	0.25 - 3.7	0.37 - 7.5	0.75 - 7.5	1.8	1.8	1.8	1.8	3	0.6
B1	5.5 - 11	11 - 18.5	-	1.8	1.8	1.5	1.5	3	0.6
B2	15	22 30	-	2.5 4.5	2.5 4.5	3.7 3.7	3.7 3.7	3 3	0.6 0.6
B3	5.5 - 11	11 - 18.5	11 - 18.5	1.8	1.8	1.8	1.8	3	0.6
B4	11 - 18.5	18.5 - 37	18.5 - 37	4.5	4.5	4.5	4.5	3	0.6
C1	18.5 - 30	37 - 55	-	10	10	10	10	3	0.6
C2	37 45	75 90	-	14 24	14 24	14 14	14 14	3 3	0.6 0.6
C3	18.5 - 30	37 - 55	37 - 55	10	10	10	10	3	0.6
C4	30 - 45	55 - 90	55 - 90	14/24 ¹	14/24 ¹	14	14	3	0.6

Table 5.1: Tightening of terminals.

1. For different cable dimensions x/y where $x \leq 95 \text{ mm}^2$ and $y \geq 95 \text{ mm}^2$.

5.1.2. Fuses

Branch circuit protection:

In order to protect the installation against electrical and fire hazard, all branch circuits in an installation, switch gear, machines etc., must be shortcircuit and overcurrent protected according to the national/international regulations.

Short circuit protection

The frequency converter must be protected against short-circuit to avoid electrical or fire hazard. Danfoss recommends using the fuses mentioned in tables 4.3 and 4.4 to protect service personnel or other equipment in case of an internal failure in the unit. The frequency converter provides full short circuit protection in case of a short-circuit on the motor output.

Over-current protection:

Provide overload protection to avoid fire hazard due to overheating of the cables in the installation. Over current protection must always be carried out according to national regulations. The frequency converter is equipped with an internal over current protection that can be used for upstream overload protection (UL-applications excluded). See par. 4-18. Fuses must be designed for protection in a circuit capable of supplying a maximum of 100,000 A_{rms} (symmetrical), 500 V/600 V maximum.

Non UL compliance

If UL/cUL is not to be complied with, Danfoss recommends using the fuses mentioned in table 4.2, which will ensure compliance with EN50178: In case of malfunction, not following the recommendation may result in unnecessary damage to the frequency converter.

VLT AQUA	Max. fuse size	Voltage	Type
200-240 V			
K25-1K1	16A ¹	200-240 V	type gG
1K5	16A ¹	200-240 V	type gG
2K2	25A ¹	200-240 V	type gG
3K0	25A ¹	200-240 V	type gG
3K7	35A ¹	200-240 V	type gG
5K5	50A ¹	200-240 V	type gG
7K5	63A ¹	200-240 V	type gG
11K	63A ¹	200-240 V	type gG
15K	80A ¹	200-240 V	type gG
18K5	125A ¹	200-240 V	type gG
22K	125A ¹	200-240 V	type gG
30K	160A ¹	200-240 V	type gG
37K	200A ¹	200-240 V	type aR
45K	250A ¹	200-240 V	type aR
380-480 V			
K37-1K5	10A ¹	380-480 V	type gG
2K2-4K0	20A ¹	380-480 V	type gG
5K5-7K5	32A ¹	380-480 V	type gG
11K	63A ¹	380-480 V	type gG
15K	63A ¹	380-480 V	type gG
18K	63A ¹	380-480 V	type gG
22K	63A ¹	380-480 V	type gG
30K	80A ¹	380-480 V	type gG
37K	100A ¹	380-480 V	type gG
45K	125A ¹	380-480 V	type gG
55K	160A ¹	380-480 V	type gG
75K	250A ¹	380-480 V	type aR
90K	250A ¹	380-480 V	type aR

Table 5.2: Non UL fuses 200 V to 480 V

1) Max. fuses - see national/international regulations for selecting an applicable fuse size.

UL Compliance

VLT AQUA	Bussmann	Bussmann	Bussmann	SIBA	Littel fuse	Ferraz-Shawmut	Ferraz-Shawmut
200-240 V							
Type	Type RK1	Type J	Type T	Type RK1	Type RK1	Type CC	Type RK1
K25-1K1	KTN-R10	JKS-10	JJN-10	5017906-010	KLN-R10	ATM-R10	A2K-10R
1K5	KTN-R15	JKS-15	JJN-15	5017906-015	KLN-R15	ATM-R15	A2K-15R
2K2	KTN-R20	JKS-20	JJN-20	5012406-020	KLN-R20	ATM-R20	A2K-20R
3K0	KTN-R25	JKS-25	JJN-25	5012406-025	KLN-R25	ATM-R25	A2K-25R
3K7	KTN-R30	JKS-30	JJN-30	5012406-030	KLN-R30	ATM-R30	A2K-30R
5K5	KTN-R50	JKS-50	JJN-50	5012406-050	KLN-R50	-	A2K-50R
7K5	KTN-R50	JKS-60	JJN-60	5012406-050	KLN-R60	-	A2K-50R
11K	KTN-R60	JKS-60	JJN-60	5014006-063	KLN-R60	-	A2K-60R
15K	KTN-R80	JKS-80	JJN-80	5014006-080	KLN-R80	-	A2K-80R
18K5	KTN-R125	JKS-150	JJN-125	2028220-125	KLN-R125	-	A2K-125R
22K	KTN-R125	JKS-150	JJN-125	2028220-125	KLN-R125	-	A2K-125R
30K	FWX-150	-	-	2028220-150	L25S-150	-	A25X-150
37K	FWX-200	-	-	2028220-200	L25S-200	-	A25X-200
45K	FWX-250	-	-	2028220-250	L25S-250	-	A25X-250

Table 5.3: UL fuses 200 - 240 V

VLT AQUA	Bussmann	Bussmann	Bussmann	SIBA	Littel fuse	Ferraz-Shawmut	Ferraz-Shawmut
380-480 V, 525-600 V							
kW	Type RK1	Type J	Type T	Type RK1	Type RK1	Type CC	Type RK1
K37-1K1	KTS-R6	JKS-6	JJS-6	5017906-006	KLS-R6	ATM-R6	A6K-6R
1K5-2K2	KTS-R10	JKS-10	JJS-10	5017906-010	KLS-R10	ATM-R10	A6K-10R
3K0	KTS-R15	JKS-15	JJS-15	5017906-016	KLS-R16	ATM-R16	A6K-16R
4K0	KTS-R20	JKS-20	JJS-20	5017906-020	KLS-R20	ATM-R20	A6K-20R
5K5	KTS-R25	JKS-25	JJS-25	5017906-025	KLS-R25	ATM-R25	A6K-25R
7K5	KTS-R30	JKS-30	JJS-30	5012406-032	KLS-R30	ATM-R30	A6K-30R
11K	KTS-R40	JKS-40	JJS-40	5014006-040	KLS-R40	-	A6K-40R
15K	KTS-R40	JKS-40	JJS-40	5014006-040	KLS-R40	-	A6K-40R
18K	KTS-R50	JKS-50	JJS-50	5014006-050	KLS-R50	-	A6K-50R
22K	KTS-R60	JKS-60	JJS-60	5014006-063	KLS-R60	-	A6K-60R
30K	KTS-R80	JKS-80	JJS-80	2028220-100	KLS-R80	-	A6K-80R
37K	KTS-R100	JKS-100	JJS-100	2028220-125	KLS-R100	-	A6K-100R
45K	KTS-R125	JKS-150	JJS-150	2028220-125	KLS-R125	-	A6K-125R
55K	KTS-R150	JKS-150	JJS-150	2028220-160	KLS-R150	-	A6K-150R
75K	FWH-220	-	-	2028220-200	L50S-225	-	A50-P225
90K	FWH-250	-	-	2028220-250	L50S-250	-	A50-P250

Table 5.4: UL fuses 380 - 600 V

KTS-fuses from Bussmann may substitute KTN for 240 V frequency converters.

FWH-fuses from Bussmann may substitute FWX for 240 V frequency converters.

KLSR fuses from LITTEL FUSE may substitute KLNK fuses for 240 V frequency converters.

L50S fuses from LITTEL FUSE may substitute L50S fuses for 240 V frequency converters.

A6KR fuses from FERRAZ SHAWMUT may substitute A2KR for 240 V frequency converters.

A50X fuses from FERRAZ SHAWMUT may substitute A25X for 240 V frequency converters.

5.1.3. Earthing and IT mains



The earth connection cable cross section must be at least 10 mm² or 2 rated mains wires terminated separately according to *EN 50178* or *IEC 61800-5-1* unless national regulations specify differently. Always comply with national and local regulations on cable cross-sections.

The mains is connected to the main disconnect switch if this is included.



NB!

Check that mains voltage corresponds to the mains voltage of the frequency converter name plate.

5

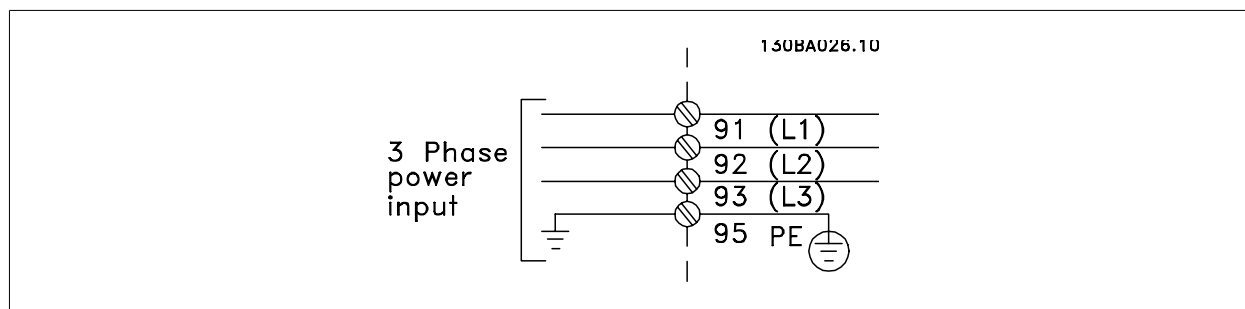

Illustration 5.1: Terminals for mains and earthing.



IT Mains

Do not connect 400 V frequency converters with RFI-filters to mains supplies with a voltage between phase and earth of more than 440 V.

For IT mains and delta earth (grounded leg), mains voltage may exceed 440 V between phase and earth.

5.1.4. Mains wiring overview

Please use the following table to follow mains wiring connection instructions.

Enclosure:	A2 (IP 20/ IP 21)	A3 (IP 20/ IP 21)	A5 (IP 55/ IP 66)	B1 (IP 21/ IP 55/IP 66)	B2 (IP 21/ IP 55/IP 66)	C1 (IP 21/ IP 55/66)	C2 (IP 21/ IP 55/66)
Motor size:							
200-240 V	0.25-3.0 kW	3.7 kW	0.25-3.7 kW	5.5-7.5 kW	11-15 kW	18.5-22 kW	30-45 kW
380-480 V	0.37-4.0 kW	5.5-7.5 kW	0.37-7.5 kW	11-18.5 kW	22-30 kW	37-55 kW	75-90 kW
Goto:	5.1.5		5.1.6	5.1.7		5.1.8	

Table 5.5: Mains wiring table.

5.1.5. Mains connection for A2 and A3

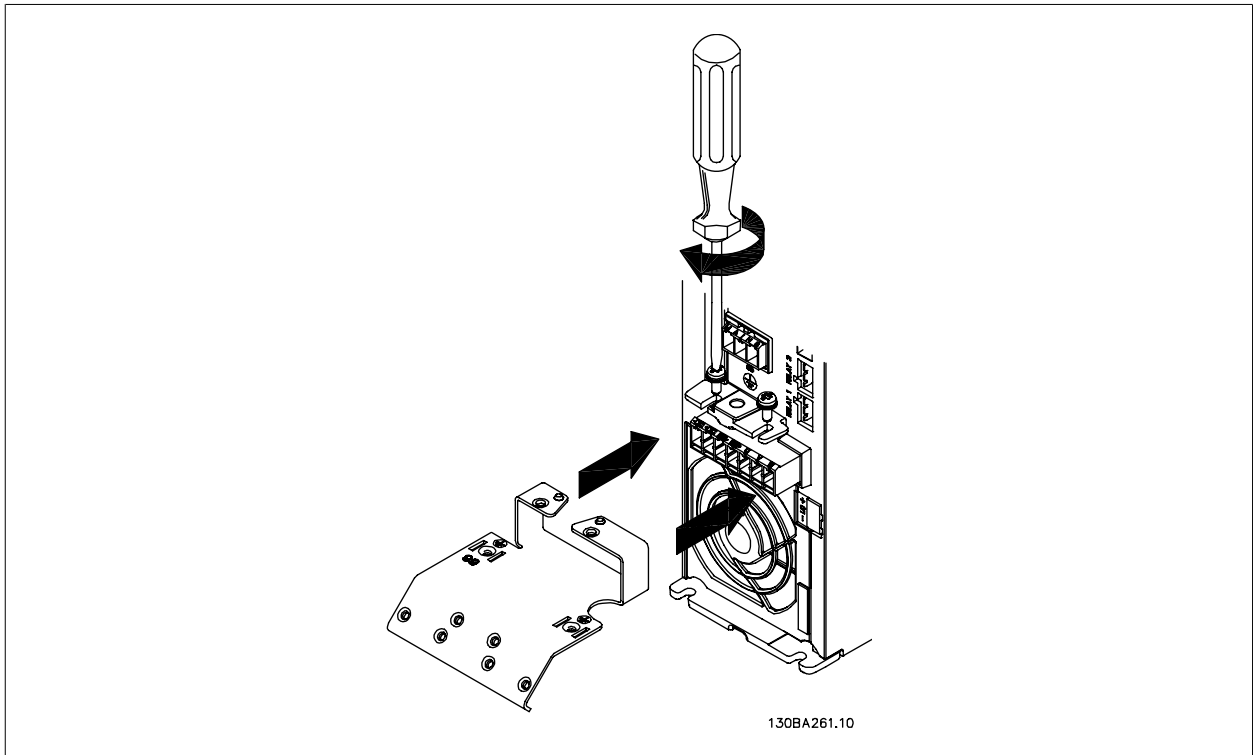

Illustration 5.2: First mount the two screws on the mounting plate, slide it into place and tighten fully.

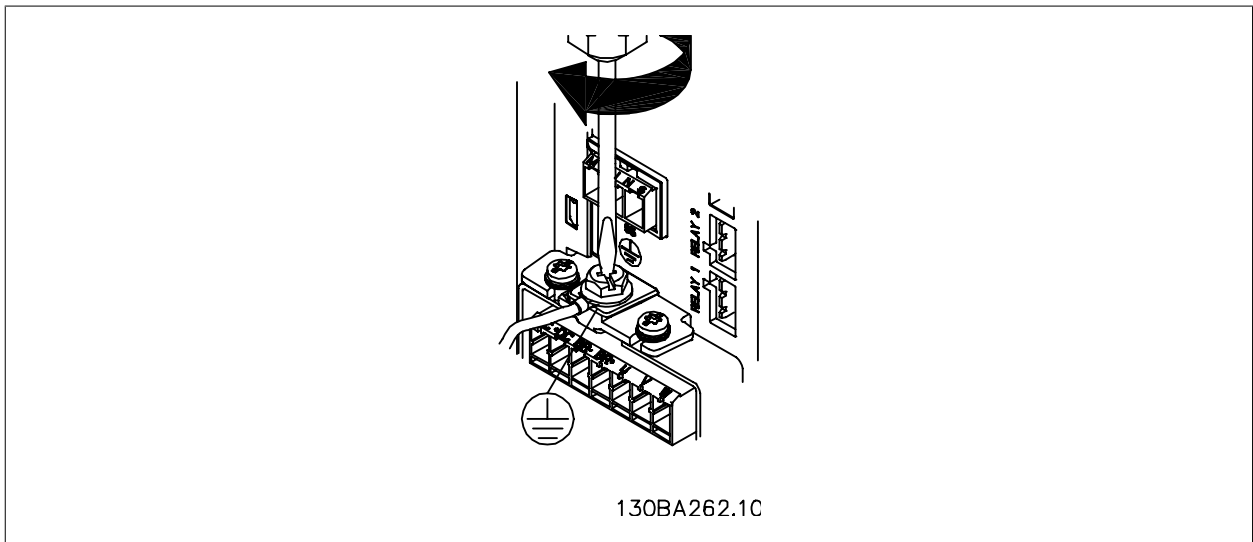

Illustration 5.3: When mounting cables, first mount and tighten earth cable.



The earth connection cable cross section must be at least 10 mm² or 2 rated mains wires terminated separately according to *EN 50178/IEC 61800-5-1*.

5

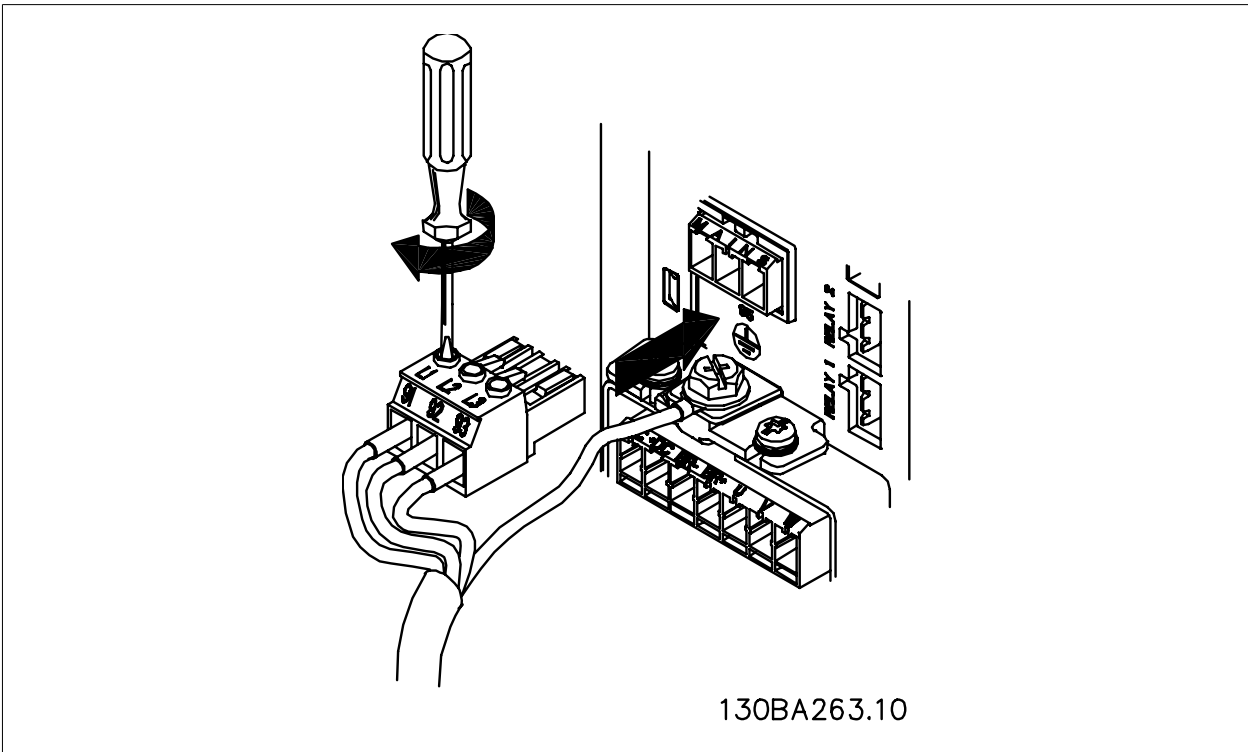

Illustration 5.4: Then mount mains plug and tighten wires.

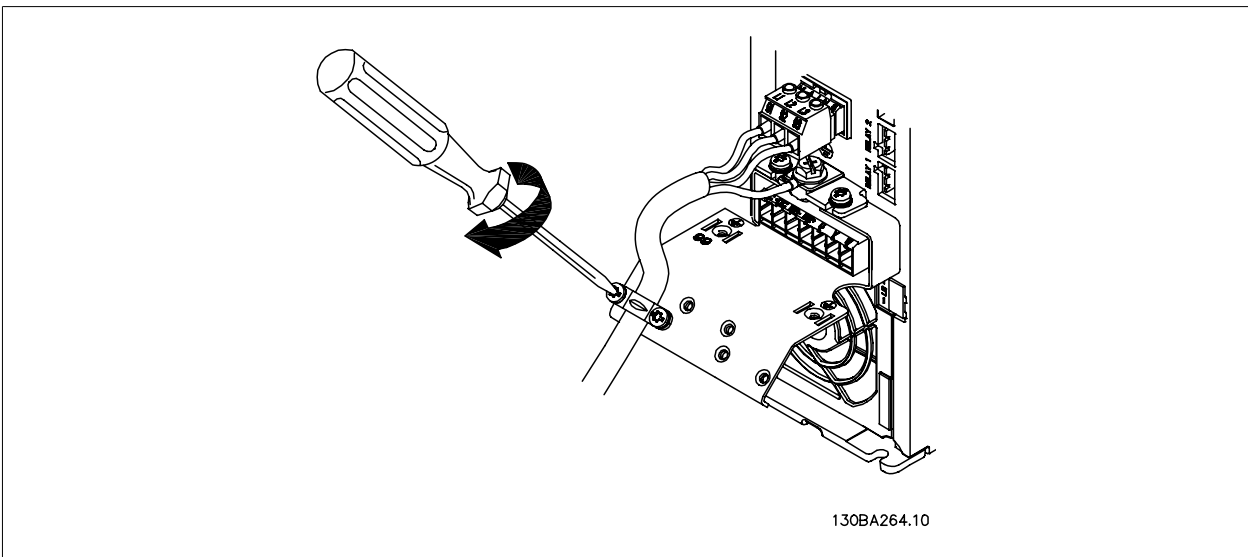

Illustration 5.5: Finally tighten support bracket on mains wires.

5.1.6. Mains connection for A5

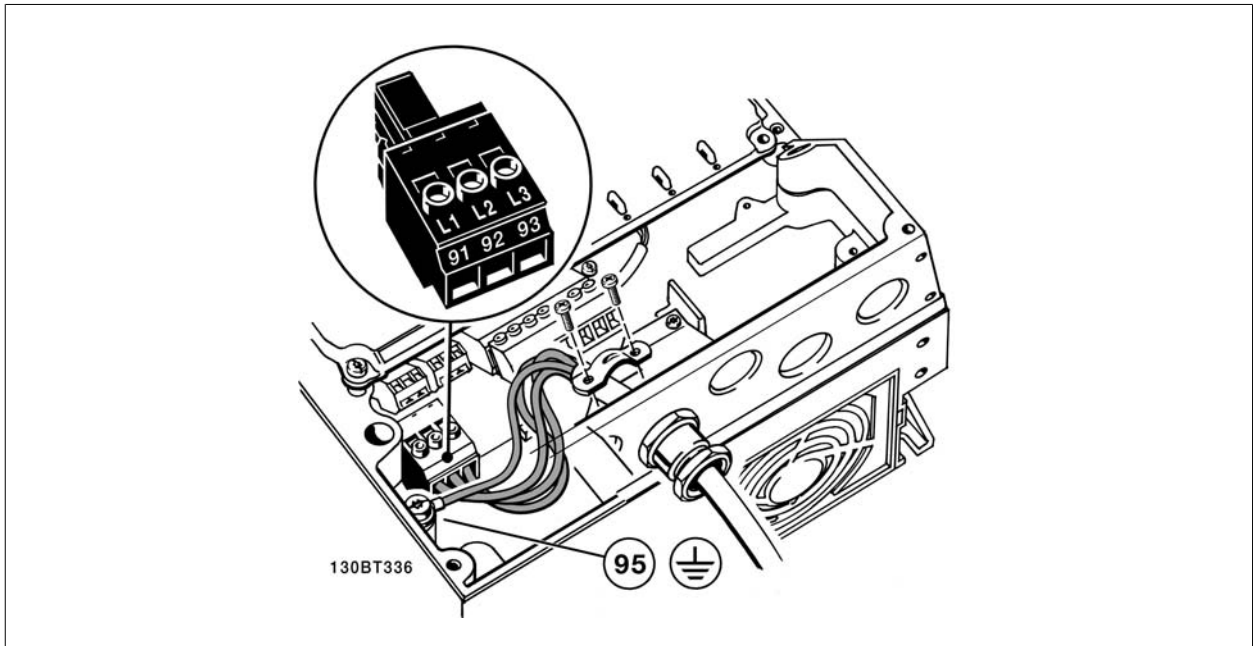

Illustration 5.6: How to connect to mains and earthing without mains disconnect switch. Note that a cable clamp is used.

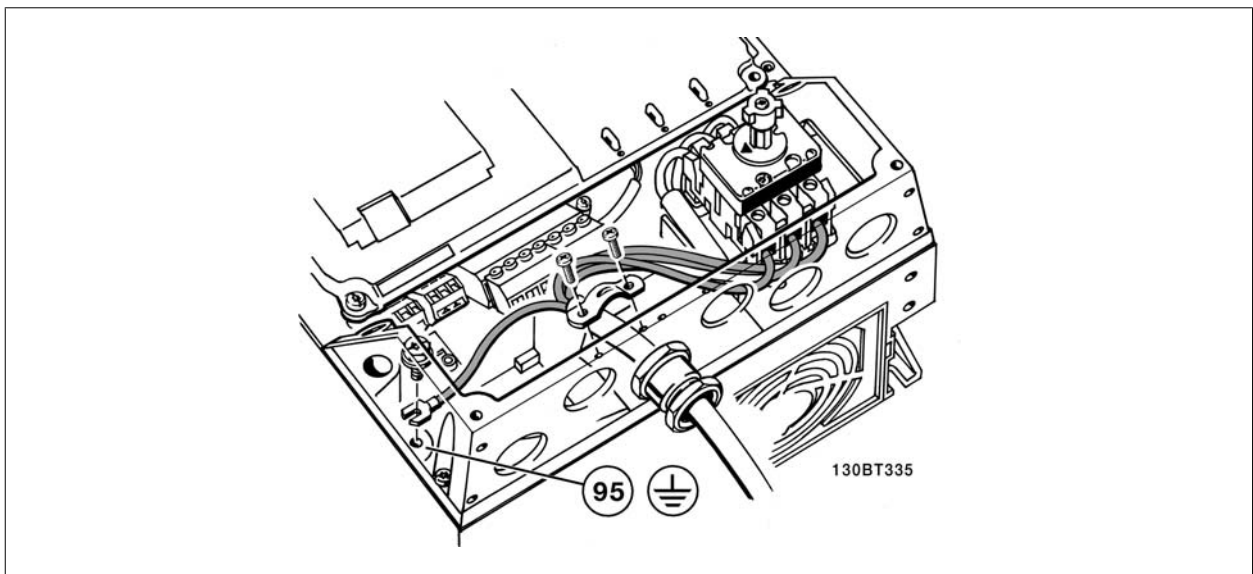

Illustration 5.7: How to connect to mains and earthing with mains disconnect switch.

5.1.7. Mains connection for B1, B2 and B3

5

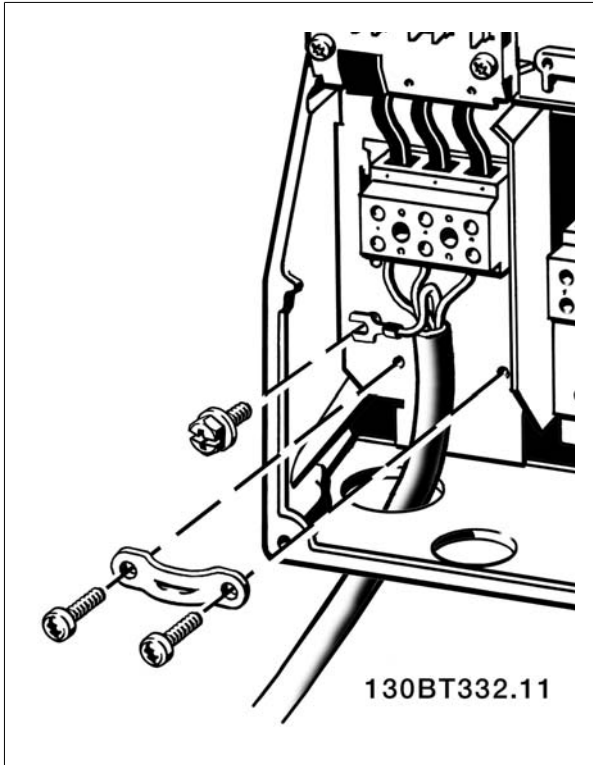

Illustration 5.8: How to connect to mains and earthing for B1 and B2.

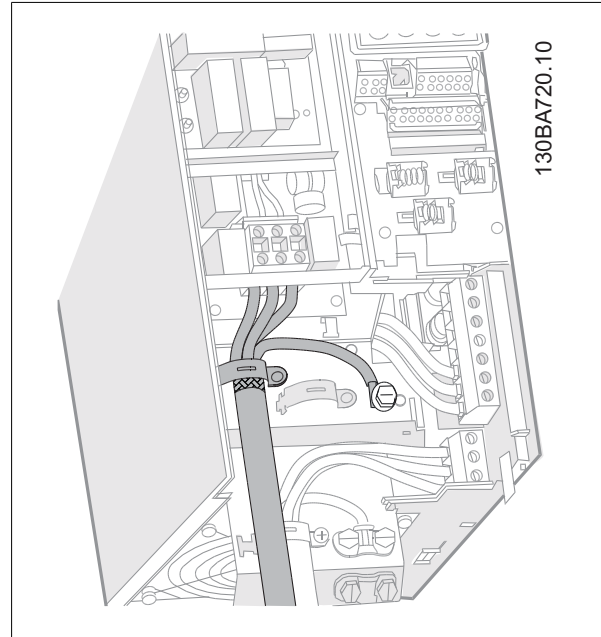

Illustration 5.9: How to connect to mains and earthing for B3 with RFI.

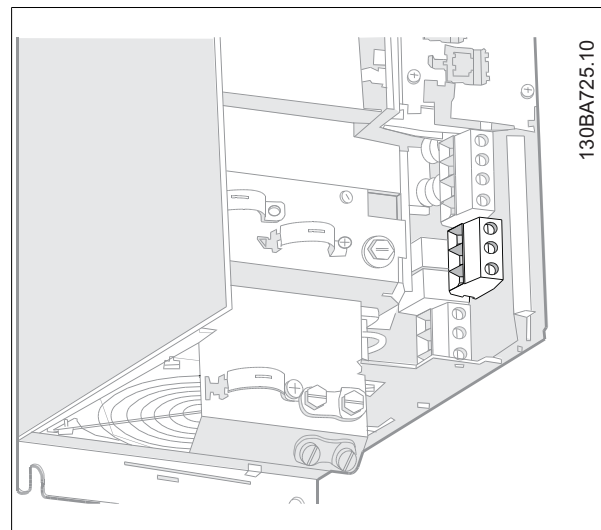

Illustration 5.10: How to connect to mains and earthing for B3 without RFI.



NB!

For correct cable dimensions please see the section General Specifications at the back of this manual.

5.1.8. Mains connection for C1 and C2

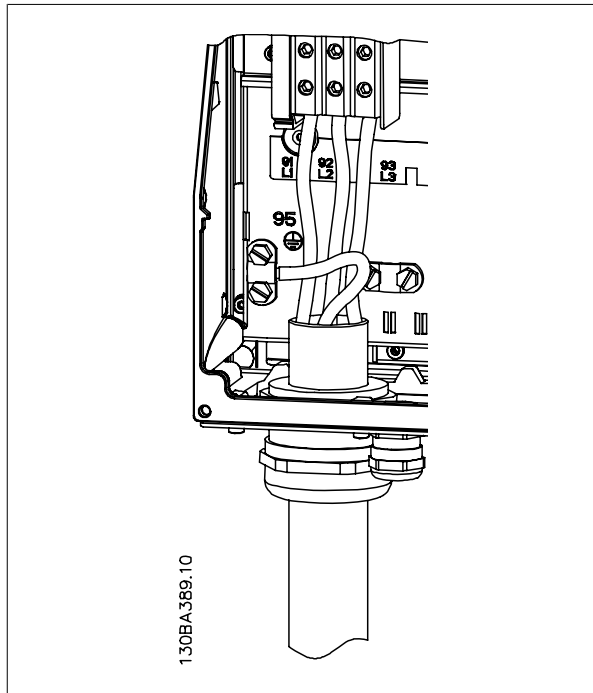

Illustration 5.11: How to connect to mains and earthing.

5.1.9. How to connect motor - foreword

See section *General Specifications* for correct dimensioning of motor cable cross-section and length.

- Use a screened/armoured motor cable to comply with EMC emission specifications (or install the cable in metal conduit).
- Keep the motor cable as short as possible to reduce the noise level and leakage currents.
- Connect the motor cable screen/armour to both the decoupling plate of the frequency converter and to the metal of the motor. (Same applies to both ends of metal conduit if used instead of screen.)
- Make the screen connections with the largest possible surface area (cable clamp or by using an EMC cable gland). This is done by using the supplied installation devices in the frequency converter.
- Avoid terminating the screen by twisting the ends (pigtailed), as this will spoil high frequency screening effects.
- If it is necessary to break the continuity of the screen to install a motor isolator or motor relay, the continuity must be maintained with the lowest possible HF impedance.

Cable length and cross-section

The frequency converter has been tested with a given length of cable and a given cross-section of that cable. If the cross-section is increased, the cable capacitance - and thus the leakage current - may increase, and the cable length must be reduced correspondingly.

Switching frequency

When frequency converters are used together with sine wave filters to reduce the acoustic noise from a motor, the switching frequency must be set according to the sine wave filter instruction in par. 14-01.

Precautions while using Aluminium conductors

Aluminium conductors are not recommended for cable cross sections below 35 mm². Terminals can accept aluminium conductors but the conductor surface has to be clean and the oxidation must be removed and sealed by neutral acid free Vaseline grease before the conductor is connected. Furthermore, the terminal screw must be retightened after two days due to the softness of the aluminium. It is crucial to ensure the connection makes a gas tight joint, otherwise the aluminium surface will oxidize again.

All types of three-phase asynchronous standard motors can be connected to the frequency converter. Normally, small motors are star-connected (230/400 V, D/Y). Large motors are delta-connected (400/690 V, D/Y). Refer to the motor name plate for correct connection mode and voltage.

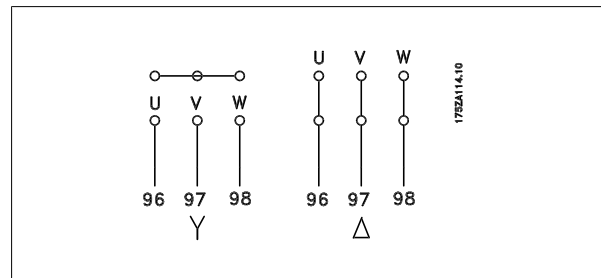

Illustration 5.12: Terminals for motor connection



NB!

In motors without phase insulation paper or other insulation reinforcement suitable for operation with voltage supply (such as a frequency converter), fit a sine-wave filter on the output of the frequency converter. (Motors that comply with IEC 60034-17 do not require an Sine-wave filter).

5

No.	96	97	98	Motor voltage 0-100% of mains voltage.
	U	V	W	3 cables out of motor
	U1	V1	W1	6 cables out of motor, Delta-connected
	W2	U2	V2	
	U1	V1	W1	6 cables out of motor, Star-connected
				U2, V2, W2 to be interconnected separately (optional terminal block)
No.	99			Earth connection
	PE			

Table 5.6: 3 and 6 cable motor connection.

5.1.10. Motor wiring overview

Enclosure:	A2 (IP 20/ IP 21)	A3 (IP 20/ IP 21)	A5 (IP 55/ IP 66)	B1 (IP 21/ IP 55/IP 66)	B2 (IP 21/ IP 55/IP 66)	C1 (IP 21/ IP 55/IP 66)	C2 (IP 21/ IP 55/IP 66)
	130BA340.10	130BA341.10	130BA342.10	130BA343.10	130BA344.10	130BA345.10	130BA346.10
Motor size:							
200-240 V	0.25-3.0 kW	3.7 kW	0.25-3.7 kW	5.5-7.5 kW	11-15 kW	18.5-22 kW	30-45 kW
380-480 V	0.37-4.0 kW	5.5-7.5 kW	0.37-7.5 kW	11-18.5 kW	22-30 kW	37-55 kW	75-90 kW
Goto:	5.1.11		5.1.12	5.1.13		5.1.14	

Table 5.7: Motor wiring table.

5.1.11. Motor connection for A2 and A3

Follow these drawings step by step for connecting the motor to the frequency converter.

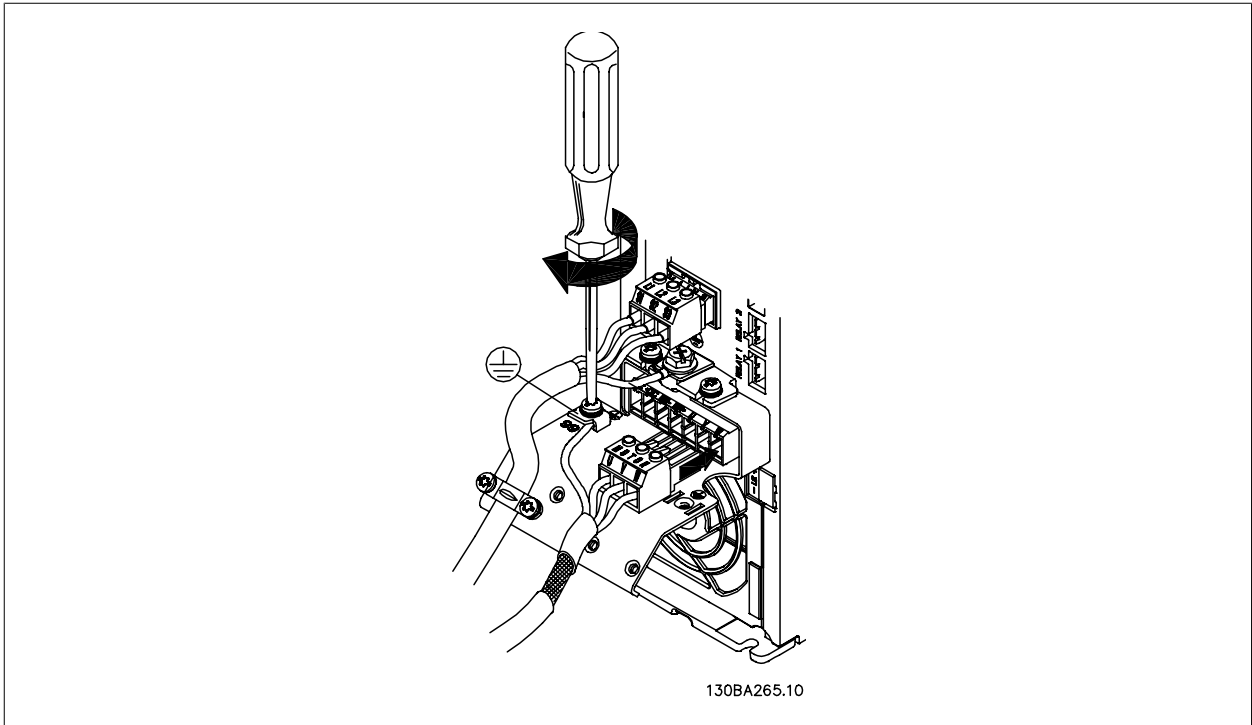

Illustration 5.13: First terminate the motor earth, then place motor U, V and W wires in plug and tighten.

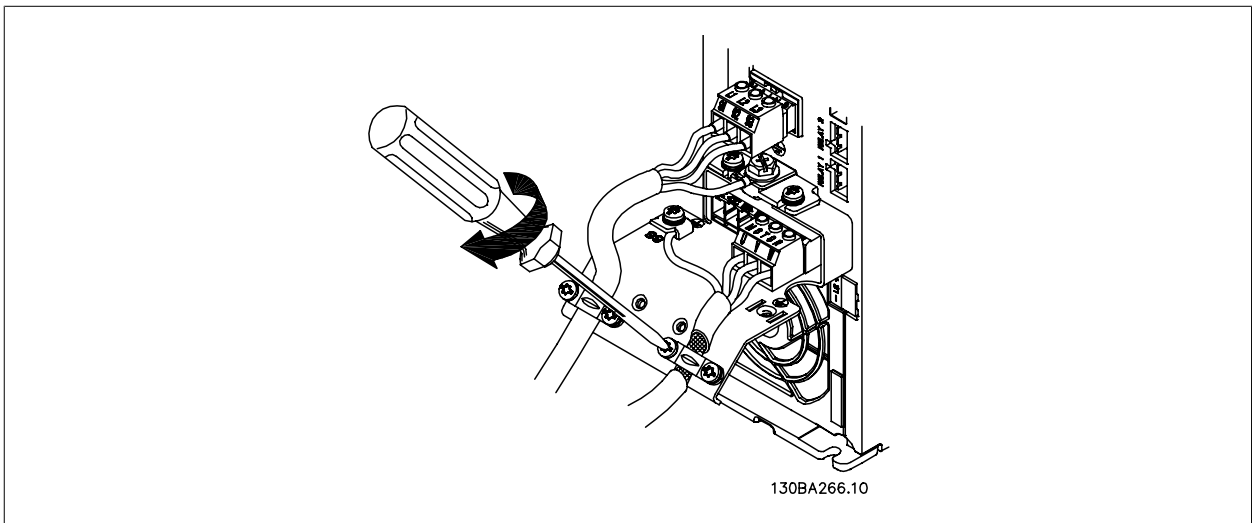

Illustration 5.14: Mount cable clamp to ensure 360 degree connection between chassis and screen, note the outer insulation of the motor cable is removed under the clamp.

5.1.12. Motor connection for A5

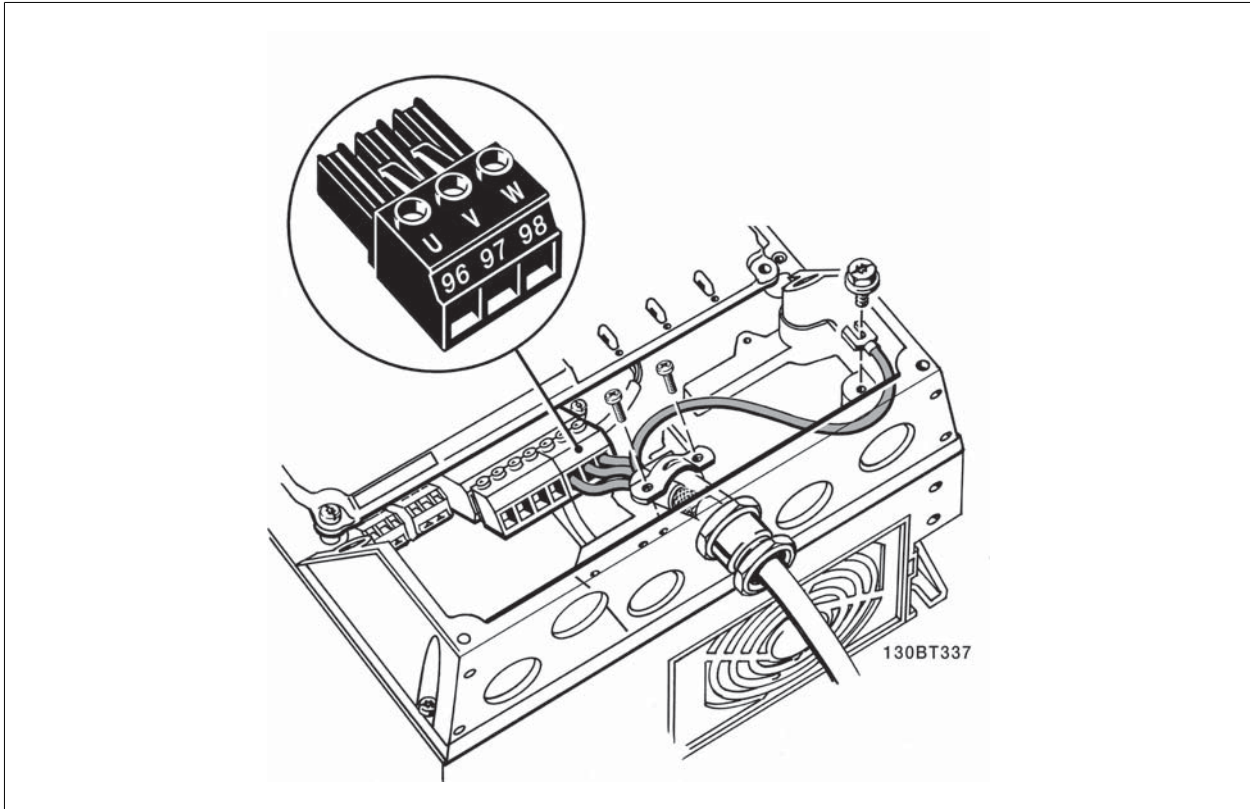

Illustration 5.15: First terminate the motor earth, then place motor U, V and W wires in terminal and tighten. Please ensure that the outer insulation of the motor cable is removed under the EMC clamp.

5.1.13. Motor connection for B1 and B2

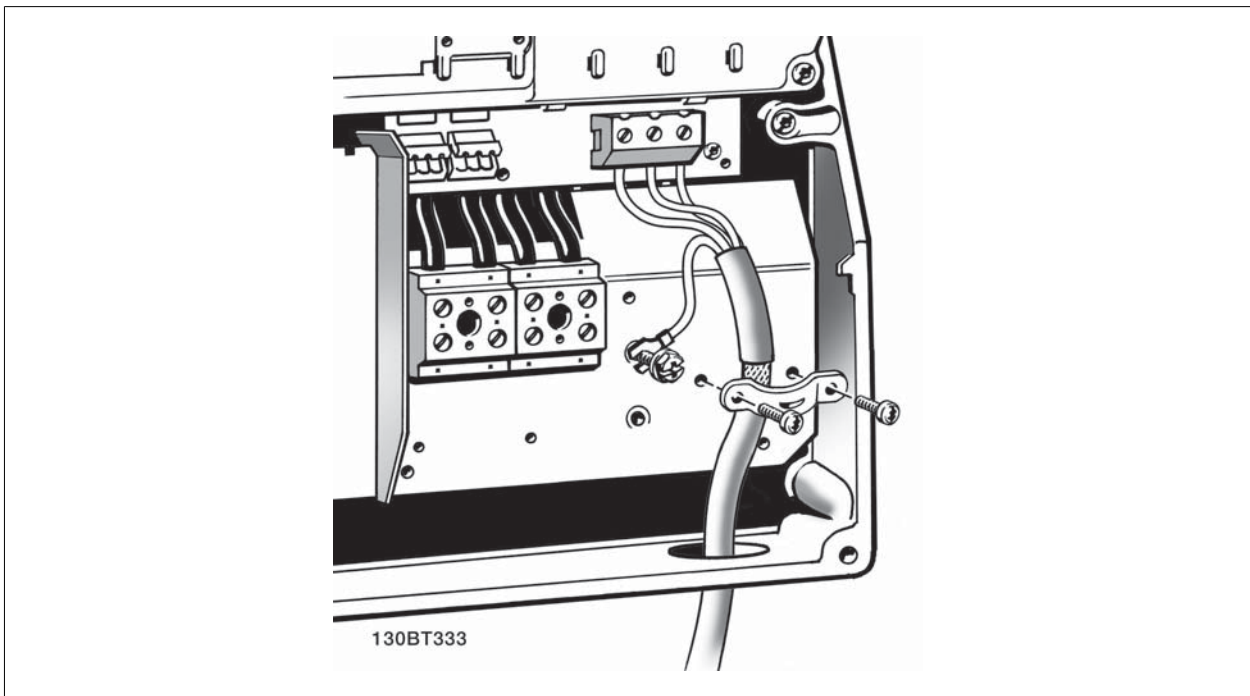

Illustration 5.16: First terminate the motor earth, then Place motor U, V and W wires in terminal and tighten. Please ensure that the outer insulation of the motor cable is removed under the EMC clamp.

5.1.14. Motor connection for C1 and C2

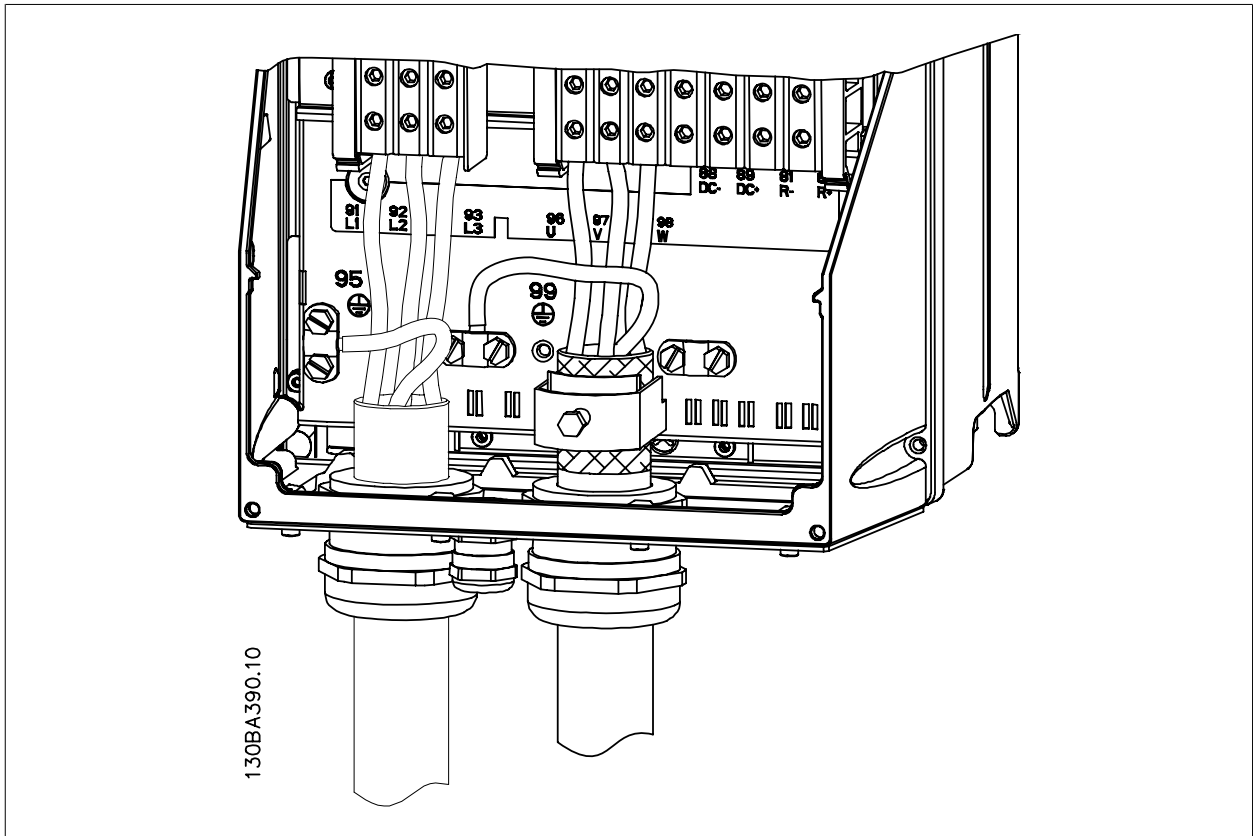

Illustration 5.17: First terminate the motor earth, then Place motor U, V and W wires in terminal and tighten. Please ensure that the outer insulation of the motor cable is removed under the EMC clamp.

5.1.15. Wiring Example and Testing

The following section describes how to terminate control wires and how to access them. For an explanation of the function, programming and wiring of the control terminals, please see chapter, *How to programme the frequency converter*.

5.1.16. Access to Control Terminals

All terminals to the control cables are located underneath the terminal cover on the front of the frequency converter. Remove the terminal cover with a screwdriver.

5

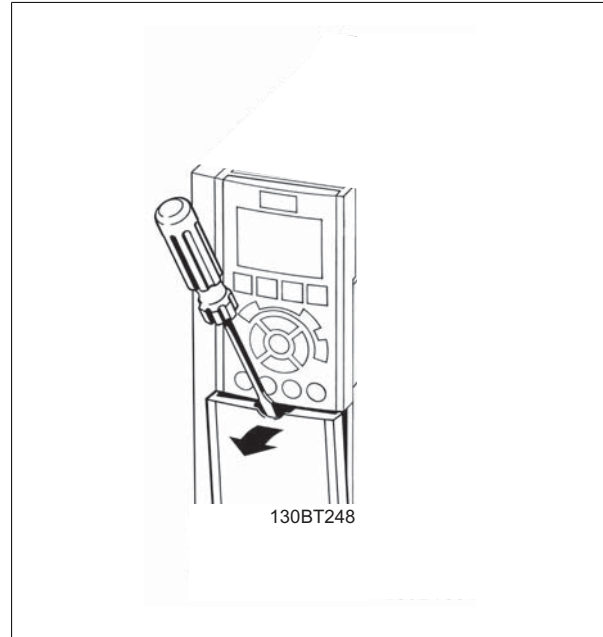

Illustration 5.18: Access to control terminals for A2, A3, B3, B4, C3 and C4 enclosures

Remove front-cover to access control terminals. When replacing the front-cover, please ensure proper fastening by applying a torque of 2 Nm.

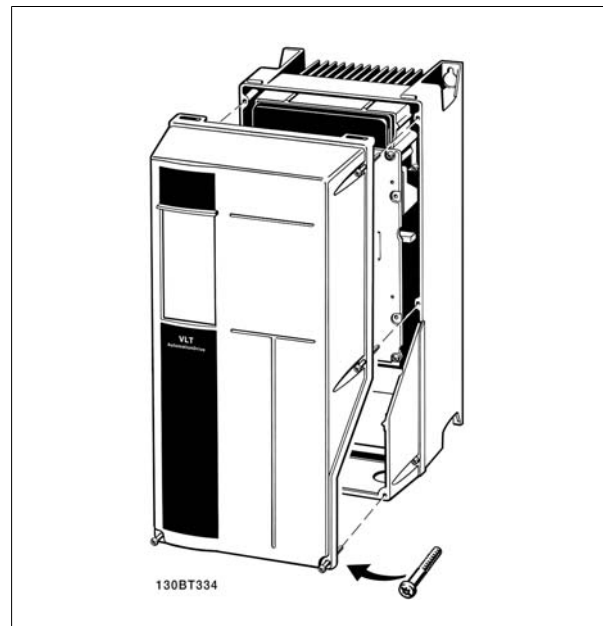

Illustration 5.19: Access to control terminals for A5, B1,B2, C1 and C2 enclosures

5.1.17. Control Terminals

Drawing reference numbers:

1. 10 pole plug digital I/O.
2. 3 pole plug RS-485 Bus.
3. 6 pole analog I/O.
4. USB connection.

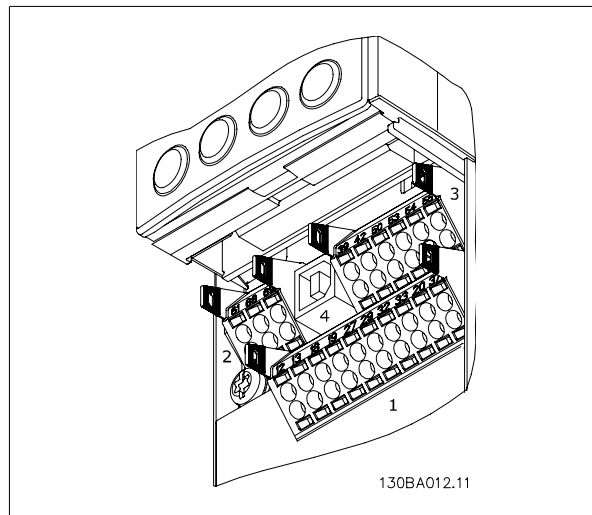



Illustration 5.20: Control terminals (all enclosures)

5.1.18. How to Test Motor and Direction of Rotation.



Note that unintended motor start can occur, ensure no personnel or equipment is in danger!

Please follow these steps to test the motor connection and direction of rotation. Start with no power to the unit.

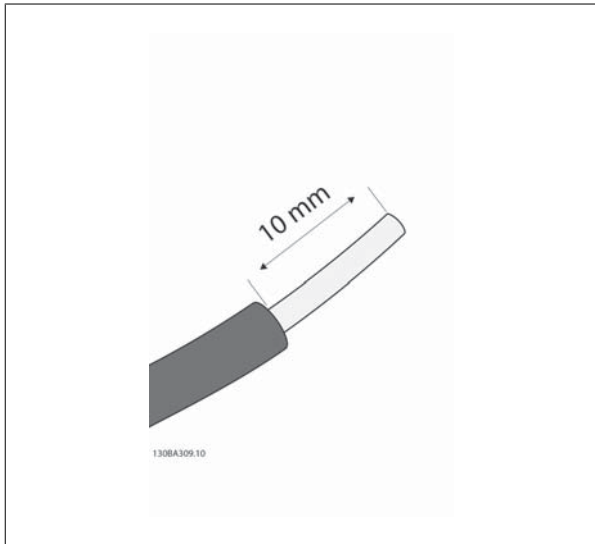

Illustration 5.21:

Step 1: First remove the insulation on both ends of a 50 to 70 mm piece of wire.

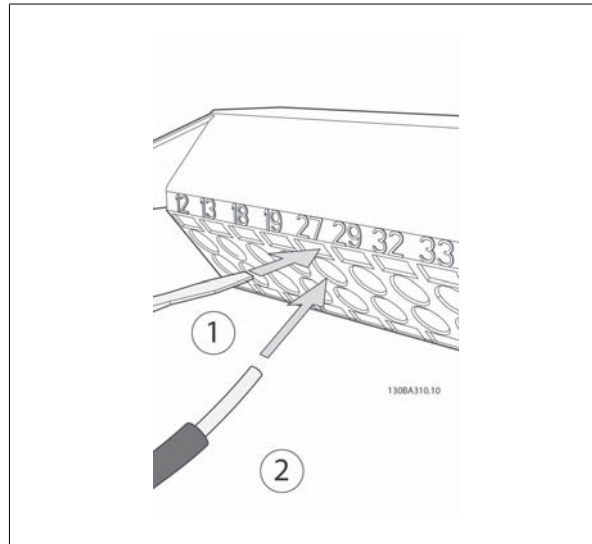

Illustration 5.22:

Step 2: Insert one end in terminal 27 using a suitable terminal screwdriver. (Note: For units with Safe Stop function, the existing jumper between terminal 12 and 37 should not be removed for the unit to be able to run!)

5

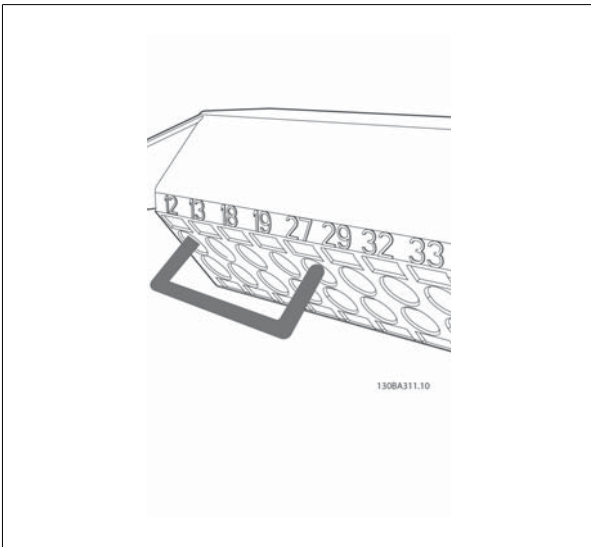

Illustration 5.23:

Step 3: Insert the other end in terminal 12 or 13. (Note: For units with Safe Stop function, the existing jumper between terminal 12 and 37 should not be removed for the unit to be able to run!)



Illustration 5.24:

Step 4: Power-up the unit and press the [Off] button. In this state the motor should not rotate. Press [Off] to stop the motor at any time. Note the LED at the [OFF] button should be lit. If alarms or warnings are flashing, please see chapter 7 regarding these.

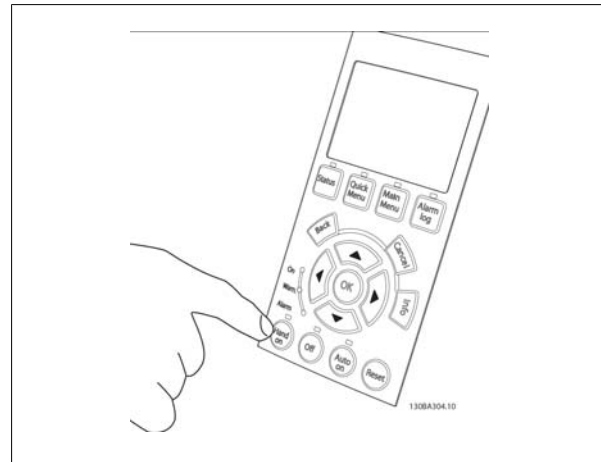

Illustration 5.25:

Step 5: By pressing the [Hand on] button, the LED above the button should be lit and the motor may rotate.



Illustration 5.26:

Step 6: The speed of the motor can be seen in the LCP. It can be adjusted by pushing the up ▲ and down ▼ arrow buttons.



Illustration 5.27:

Step 7: To move the cursor, use the left ◀ and right ▶ arrow buttons. This enables changing the speed in larger increments.

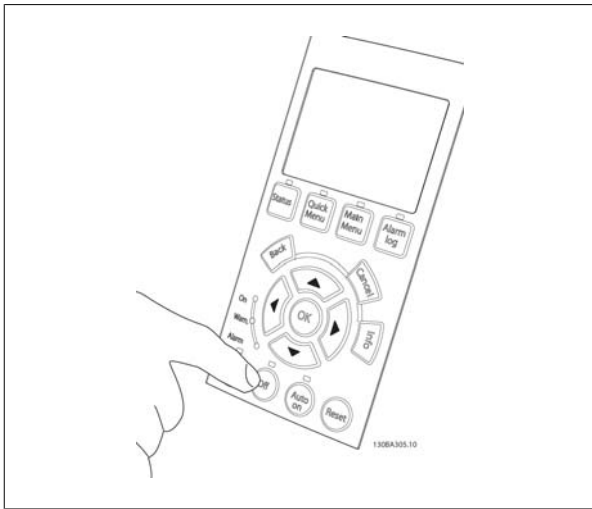

Illustration 5.28:

Step 8: Press the [Off] button to stop the motor again.

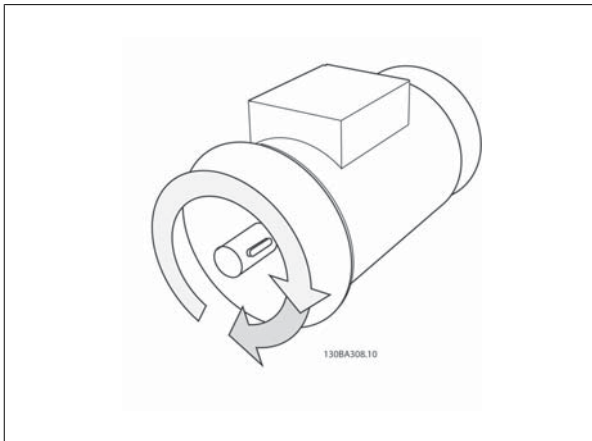



Illustration 5.29:

Step 9: Change two motor wires if the desired rotation of direction is not achieved.



Remove mains power from the frequency converter before changing motor wires.

5.1.19. Electrical Installation and Control Cables

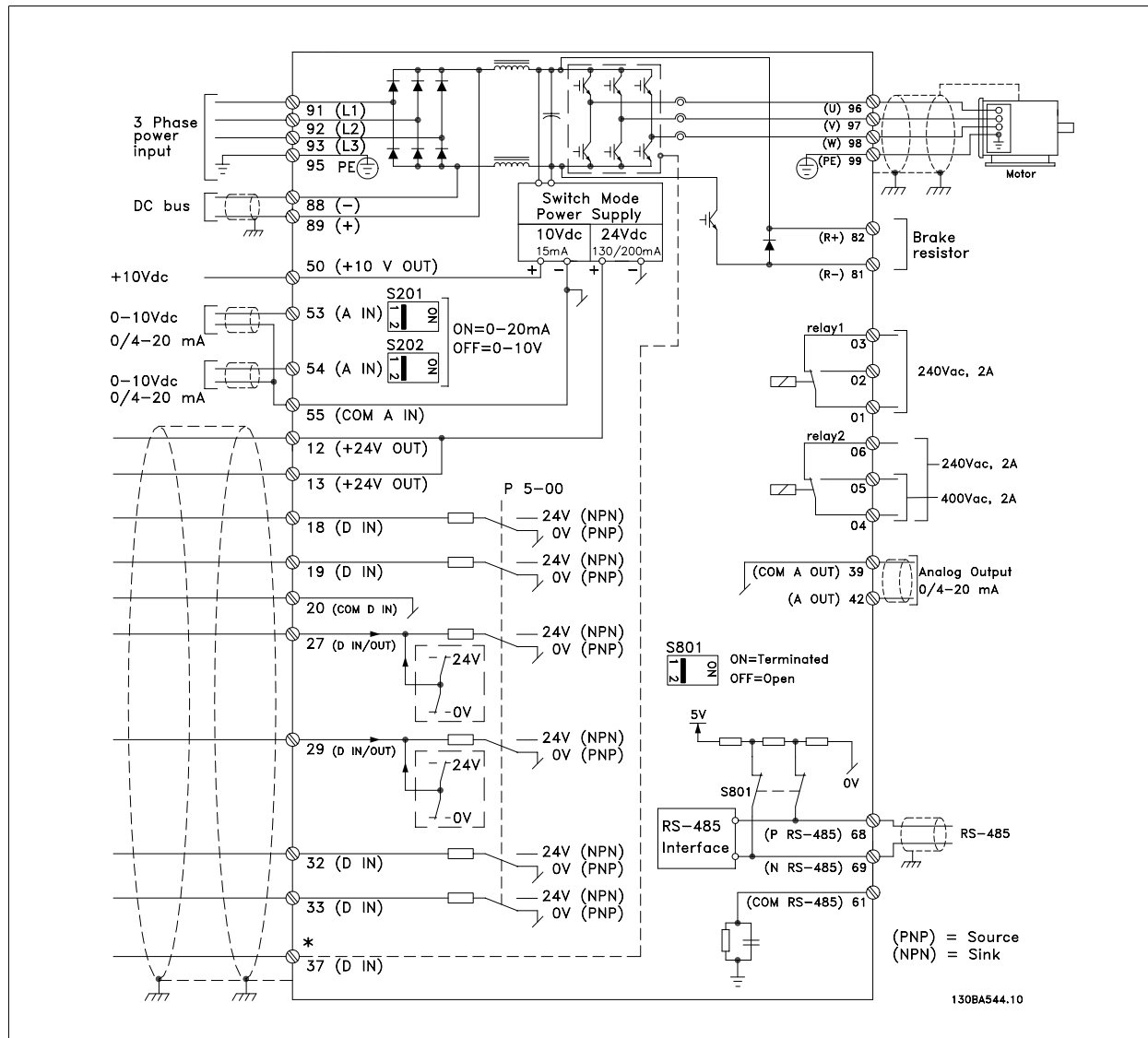

Illustration 5.30: Diagram showing all electrical terminals. (Terminal 37 present for units with Safe Stop Function only.)

Very long control cables and analog signals may, in rare cases and depending on installation, result in 50/60 Hz earth loops due to noise from mains supply cables.

If this occurs, break the screen or insert a 100 nF capacitor between screen and chassis.

NB!
The common of digital / analog inputs and outputs should be connected to separate common terminals 20, 39, and 55. This will avoid ground current interference among groups. For example, it avoids switching on digital inputs disturbing analog inputs.

NB!
Control cables must be screened/armoured.

1. Use a clamp from the accessory bag to connect screen to frequency converter decoupling plate for control cables.

See section entitled *Earthing of Screened/Armoured Control Cables* for the correct termination of control cables.

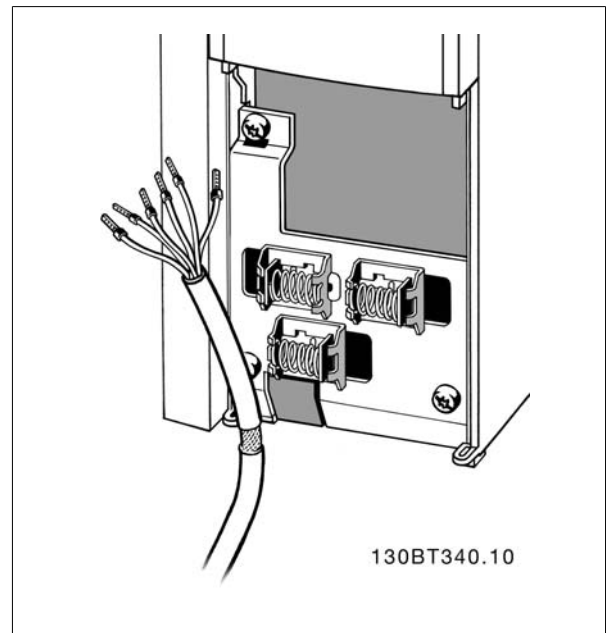

Illustration 5.31: Control cable clamp.

5.1.20. Switches S201, S202, and S801

Switches S201 (AI 53) and S202 (AI 54) are used to select a current (0-20 mA) or a voltage (0 to 10 V) configuration of the analog input terminals 53 and 54 respectively.

Switch S801 (BUS TER.) can be used to enable termination on the RS-485 port (terminals 68 and 69).

Please note that the switches may be covered by an option, if fitted.

Default setting:

- S201 (AI 53) = OFF (voltage input)
- S202 (AI 54) = OFF (voltage input)
- S801 (Bus termination) = OFF

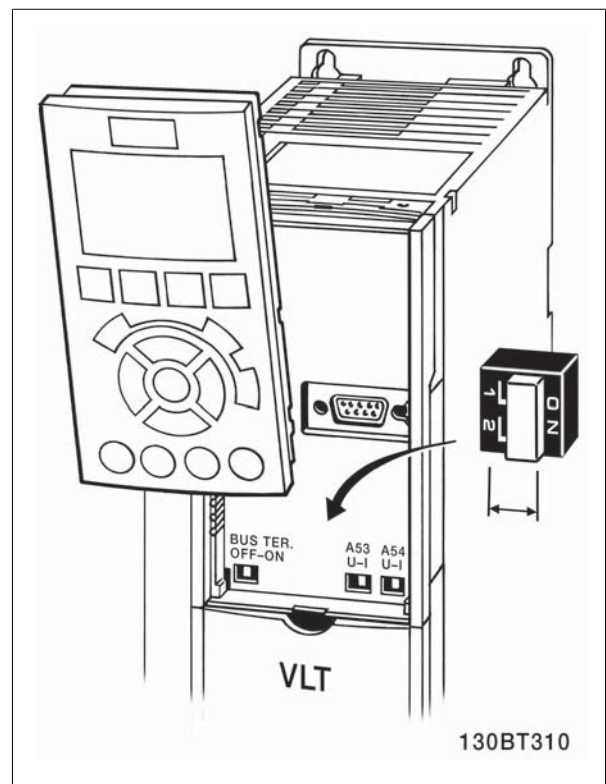

Illustration 5.32: Switches location.

5.2. Final optimization and test

5.2.1. Final optimization and test

To optimize motor shaft performance and optimize the frequency converter for the connected motor and installation, please follow these steps. Ensure that frequency converter and motor are connected, and power is applied to frequency converter.



NB!

Before power up ensure that connected equipment is ready for use.

Step 1. Locate motor name plate.



NB!

The motor is either star- (Y) or delta- connected (Δ). This information is located on the motor name plate data.

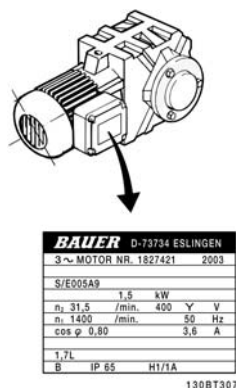

Illustration 5.33: Motor name plate example

Step 2. Enter motor name plate data in following parameter list.

To access list first press [QUICK MENU] key then select "Q2 Quick Setup".

1.	Motor Power [kW] or Motor Power [HP]	par. 1-20 par. 1-21
2.	Motor Voltage	par. 1-22
3.	Motor Frequency	par. 1-23
4.	Motor Current	par. 1-24
5.	Motor Nominal Speed	par. 1-25

Table 5.8: Motor related parameters

Step 3. Activate Automatic Motor Adaptation (AMA)

Performing AMA ensures best possible performance. AMA automatically takes measurements from the specific motor connected and compensates for installation variances.

1. Connect terminal 27 to terminal 12 or use [MAIN MENU] and set Terminal 27 par. 5-12 to *No operation* (par. 5-12 [0])
2. Press [QUICK MENU], select "Q2 Quick Setup", scroll down to AMA par. 1-29.
3. Press [OK] to activate the AMA par. 1-29.
4. Choose between complete or reduced AMA. If sine wave filter is mounted, run only reduced AMA, or remove sine wave filter during AMA procedure.
5. Press [OK] key. Display should show "Press [Hand on] to start".
6. Press [Hand on] key. A progress bar indicates if AMA is in progress.

Stop the AMA during operation

1. Press the [OFF] key - the frequency converter enters into alarm mode and the display shows that the AMA was terminated by the user.

Successful AMA

1. The display shows "Press [OK] to finish AMA".
2. Press the [OK] key to exit the AMA state.

Unsuccessful AMA

1. The frequency converter enters into alarm mode. A description of the alarm can be found in the *Troubleshooting* section.
2. "Report Value" in the [Alarm Log] shows the last measuring sequence carried out by the AMA, before the frequency converter entered alarm mode. This number along with the description of the alarm will assist troubleshooting. If contacting Danfoss Service, make sure to mention number and alarm description.

	<p>NB! Unsuccessful AMA is often caused by incorrectly entered motor name plate data or too big difference between the motor power size and the frequency converter power size.</p>
--	--

Step 4. Set speed limit and ramp time

Set up the desired limits for speed and ramp time.

Minimum Reference	par. 3-02
Maximum Reference	par. 3-03

Motor Speed Low Limit	par. 4-11 or 4-12
Motor Speed High Limit	par. 4-13 or 4-14

Ramp 1 Ramp Up Time [s]	par. 3-41
Ramp 1 Ramp Down Time 1 [s]	par. 3-42

6. Application Examples

6.1.1. Start/Stop

Terminal 18 = start/stop par. 5-10 [8] *Start*

Terminal 27 = No operation par. 5-12 [0] *No operation* (Default *coast inverse*)

Par. 5-10 *Digital Input*, Terminal 18 = *Start* (default)

Par. 5-12 *Digital Input*, Terminal 27 = *coast inverse* (default)

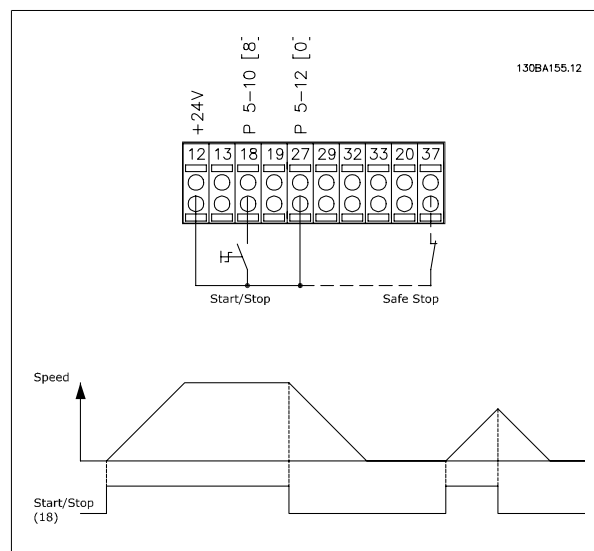

Illustration 6.1: Terminal 37: Available only with Safe Stop Function!

6.1.2. Closed Loop Wiring

Terminal 12 /13: +24V DC

Terminal 18: Start par. 5-18 [8] Start (Default)

Terminal 27: Coast par. 5-12 [2] coast inverse (Default)

Terminal 54: Analog input

L1-L3: Mains terminals

U,V and W: Motor terminals

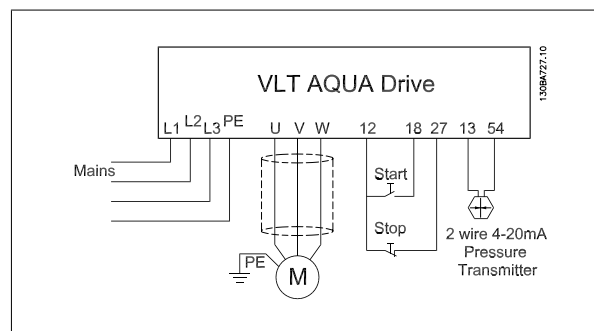

6.1.3. Submersible Pump Application

The system consists of a submersible pump controlled by a Danfoss VLT AQUA Drive and a pressure transmitter. The transmitter gives a 4-20 mA feedback signal to the VLT AQUA Drive, which keeps a constant pressure by controlling the speed of the pump. To design a drive for a submersible pump application, there are a few important issues to take into consideration. Therefore the drive used must be chosen according to motor current.

1. The motor is a so called "Can motor" with a stainless steel can between the rotor and stator. There is a larger and a more magnetic resistant air-gap than on a normal motor hence a weaker field which results in the motors being designed with a higher rated current than a norm motor with similar rated power.
2. The pump contains thrust bearings which will be damaged when running below minimum speed which normally will be 30 Hz.
3. The motor reactance is nonlinear in submersible pump motors and therefore Automatic Motor Adaption (AMA) may not be possible. However, normally submersible pumps are operated with very long motor cables that might eliminate the nonlinear motor reactance and enable the drive to perform AMA. If AMA fails, the motor data can be set from parameter group 1-3* (see motor datasheet). Be aware that if AMA has succeeded the drive will compensate for voltage drop in the long motor cables, so if the Advanced motor data are set manually, the length of the motor cable must be taken into considerations to optimize system performance.
4. It is important that the system is operated with a minimum of wear and tear of the pump and motor. A Danfoss Sine-Wave filter can lower the motor insulation stress and increase lifetime (check actual motor insulation and VLT AQUA Drive du/dt specification). It is recommended to use a filter to reduce the need for service.
5. EMC performance can be difficult to achieve due to the fact that the special pump cable which is able to withstand the wet conditions in the well normally is unshielded. A solution could be to use a screened cable above the well and fix the screen to the well pipe if it is made of steel (can also be made of plastic). A Sine-Wave filter will also reduce the EMI from unshielded motor cables.

The special "can motor" is used due to the wet installation conditions. The drive needs to be designed for the system according to output current to be able to run the motor at nominal power.

To prevent damage to the thrust bearings of the pump, it is important to ramp the pump from stop to min. speed as quick as possible. Well-known manufacturers of submersible pumps recommend that the pump is ramped to min. speed (30 Hz) in max. 2 -3 seconds. The new VLT® AQUA Drive is designed with Initial and Final Ramp for these applications. The Initial and Final ramps are 2 individual ramps, where Initial Ramp, if enabled, will ramp the motor from stop to min. speed and automatically switch to normal ramp, when min. speed is reached. Final ramp will do the opposite from min. speed to stop in a stop situation.

Pipe-Fill mode can be enabled to prevent water hammering. The Danfoss VLT AQUA Drive is capable of filling vertical pipes using the PID controller to slowly ramp up the pressure with a user specified rate (units/sec). If enabled the drive will, when it reaches min. speed after startup, enter pipe fill mode. The pressure will slowly be ramped up until it reaches a user specified Filled Set Point, where after the drive automatically disables Pipe Fill Mode and continues in normal closed loop operation.

This feature is designed for irrigation applications.

Electrical Wiring

Typical parameter settings

Typical/recommended settings in brackets().

Parameters:

Motor Rated Power Par. 1-20 / par. 1-21

Motor Rated Voltage Par. 1-22

Motor Current Par. 1-24

Motor Rated Speed Par. 1-28

Enable Automatic Motor Adaptation (AMA in par. 1-29)



NB!

Note the analog input 2, (terminal (54) format must be set to mA. (switch 202).

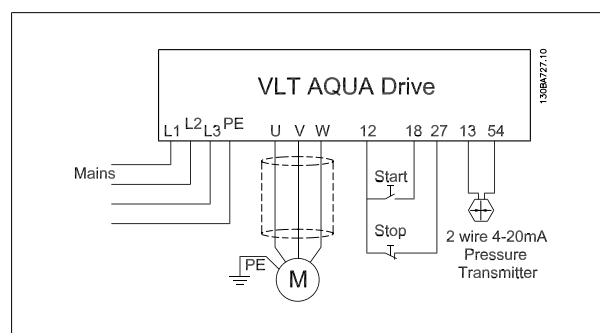

Min. Reference	Par. 3-01	(30 Hz)
Max. Reference	Par. 3-02	(50/60 Hz)
Initial Ramp Up Time	Par. 3-84	(2 sec.)
Final Ramp Down Time	Par. 3-88	(2 sec.)
Normal Ramp Up Time	Par. 3-41	(8 sec. depending on size)
Normal Ramp Down Time	Par. 3-42	(8 sec. depending on size)
Motor Min. Speed	Par. 4-11	(30 Hz)
Motor Max. Speed	Par. 4-13	(50/60 Hz)

Use the "Closed Loop" wizard under "Quick Menu_Funtion_Setup", to easily set up the feedback settings in the PID controller.

Pipe Fill Mode		
Pipe Fill Enable	Par. 29-00	
Pipe Fill Rate	Par. 29-04	(Feedback units/sec.)
Filled Set Point	Par. 29-05	(Feedback units)

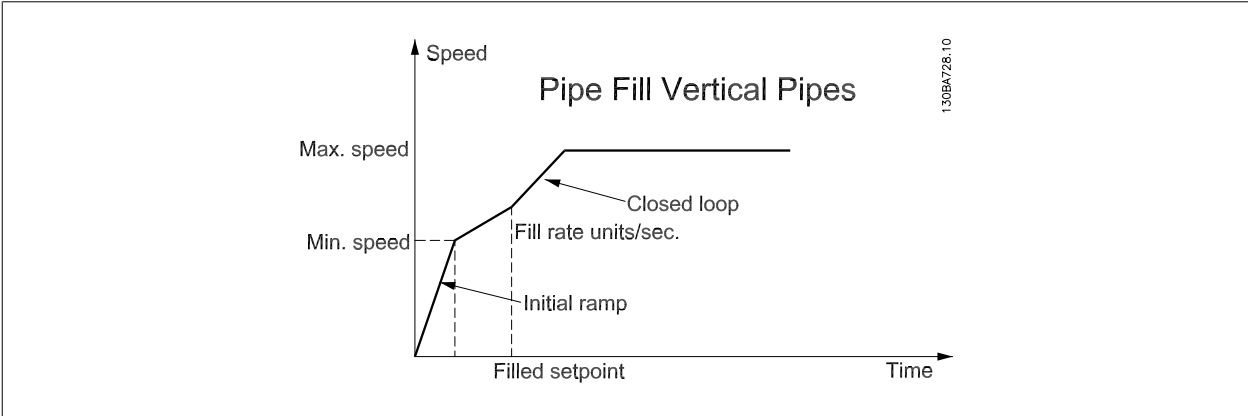

7. How to operate the frequency converter

7.1. Ways of Operation

7.1.1. Ways of Operation

The frequency converter can be operated in 3 ways:

1. Graphical Local Control Panel (GLCP), see 6.1.2
2. Numeric Local Control Panel (NLCP), see 6.1.3
3. RS-485 serial communication or USB, both for PC connection, see 6.1.4

If the frequency converter is fitted with fieldbus option, please refer to relevant documentation.

7.1.2. How to operate graphical LCP (GLCP)

The following instructions are valid for the GLCP (LCP 102).

The GLCP is divided into four functional groups:

1. Graphical display with Status lines.
2. Menu keys and indicator lights (LED's) - selecting mode, changing parameters and switching between display functions.
3. Navigation keys and indicator lights (LEDs).
4. Operation keys and indicator lights (LEDs).

Graphical display:

The LCD-display is back-lit with a total of 6 alpha-numeric lines. All data is displayed on the LCP which can show up to five operating variables while in [Status] mode.

Display lines:

- a. **Status line:** Status messages displaying icons and graphics.¹
- b. **Line 1-2:** Operator data lines displaying data and variables defined or chosen by the user. By pressing the [Status] key, up to one extra line can be added.¹
- c. **Status line:** Status messages displaying text.¹

The display is divided into 3 sections:

Top section (a)

shows the status when in status mode or up to 2 variables when not in status mode and in the case of Alarm/Warning.

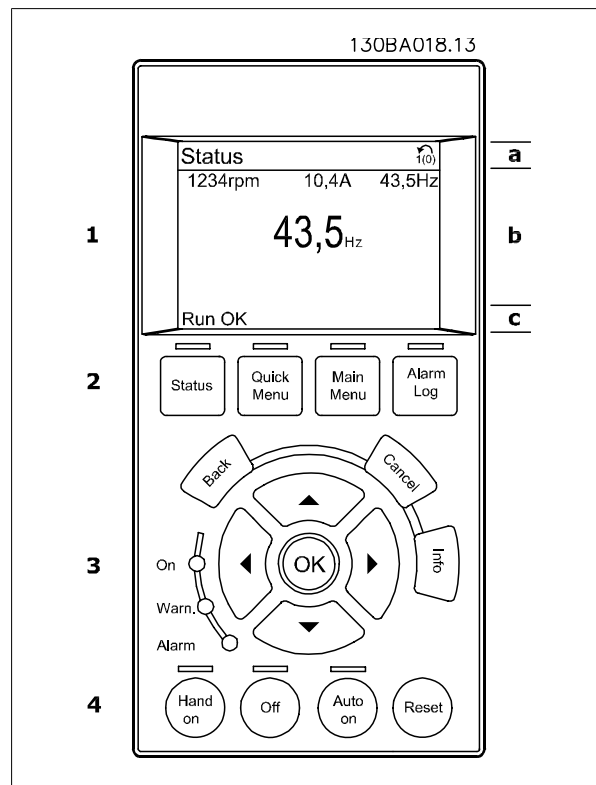

The number of the Active Set-up (selected as the Active Set-up in par. 0-10) is shown. When programming in another Set-up than the Active Set-up, the number of the Set-up being programmed appears to the right in brackets.

Middle section (b)

shows up to 5 variables with related unit, regardless of status. In case of alarm/warning, the warning is shown instead of the variables.

It is possible to toggle between three status read-out displays by pressing the [Status] key.

Operating variables with different formatting are shown in each status screen - see below.

Several values or measurements can be linked to each of the displayed operating variables. The values / measurements to be displayed can be defined via par. 0-20, 0-21, 0-22, 0-23, and 0-24, which can be accessed via [QUICK MENU], "Q3 Function Setups", "Q3-1 General Settings", "Q3-11 Display Settings".

Each value / measurement readout parameter selected in par. 0-20 to par. 0-24 has its own scale and number of digits after a possible decimal point. Larger numeric values are displayed with few digits after the decimal point.

Ex.: Current readout

5.25 A; 15.2 A 105 A.

Status display I

This read-out state is standard after start-up or initialization.

Use [INFO] to obtain information about the value/measurement linked to the displayed operating variables (1.1, 1.2, 1.3, 2, and 3).

See the operating variables shown in the display in this illustration. 1.1, 1.2 and 1.3 are shown in small size. 2 and 3 are shown in medium size.

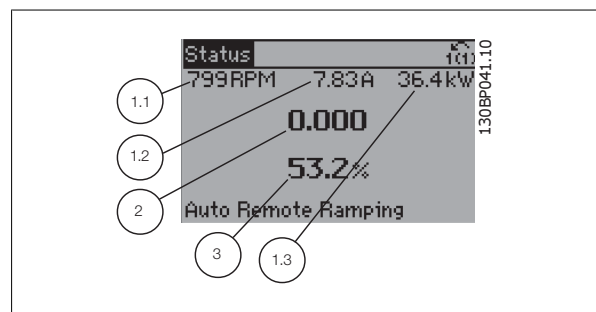

Status display II

See the operating variables (1.1, 1.2, 1.3, and 2) shown in the display in this illustration.

In the example, Speed, Motor current, Motor power and Frequency are selected as variables in the first and second lines.

1.1, 1.2 and 1.3 are shown in small size. 2 is shown in large size.

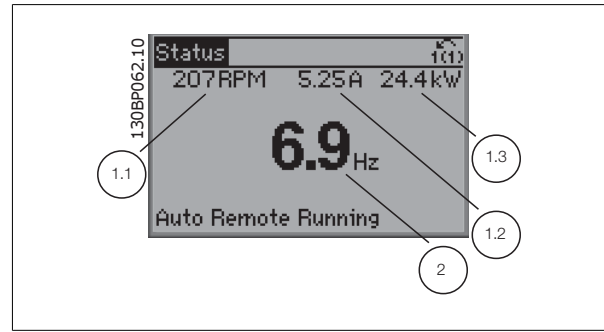

Status display III:

This state displays the event and action of the Smart Logic Control. For further information, see section *Smart Logic Control*.

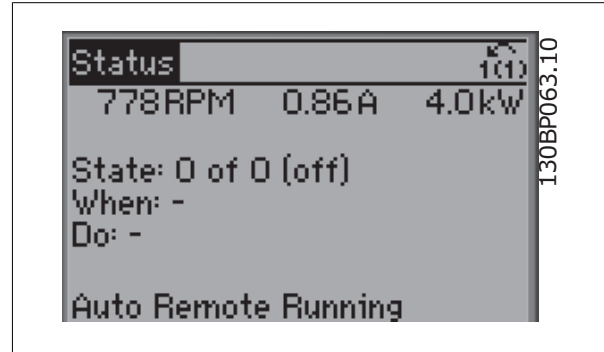

Bottom section

always shows the state of the frequency converter in Status mode.

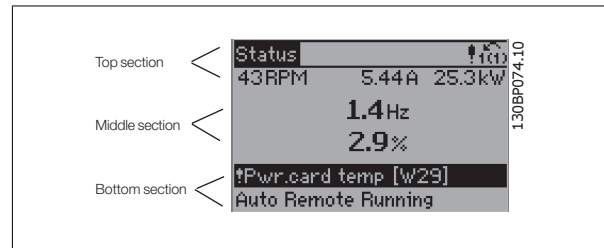

Display Contrast Adjustment

Press [status] and [▲] for darker display

Press [status] and [▼] for brighter display

Indicator lights (LEDs):

If certain threshold values are exceeded, the alarm and/or warning LED lights up. A status and alarm text appear on the control panel.

The On LED is activated when the frequency converter receives power from mains voltage, a DC bus terminal, or an external 24 V supply. At the same time, the back light is on.

- Green LED/On: Control section is working.
- Yellow LED/Warn.: Indicates a warning.
- Flashing Red LED/Alarm: Indicates an alarm.

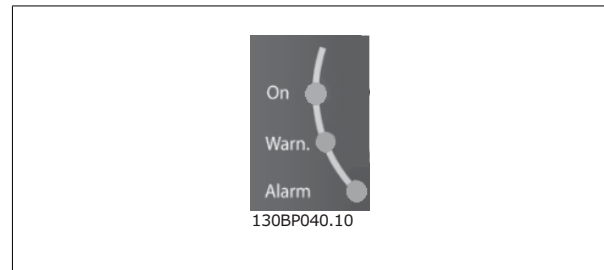

GLCP keys

Menu keys

The menu keys are divided into functions. The keys below the display and indicator lamps are used for parameter set-up, including choice of display indication during normal operation.

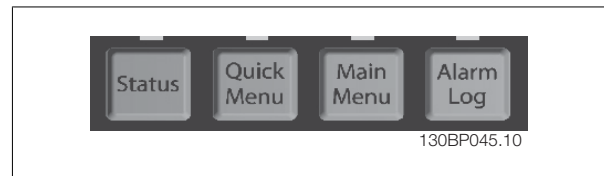

[Status]

Indicates the status of the frequency converter and/or the motor. 3 different readouts can be chosen by pressing the [Status] key:

5 line readouts, 4 line readouts or Smart Logic Control.

Use [Status] for selecting the mode of display or for changing back to Display mode from either the Quick Menu mode, the Main Menu mode or Alarm mode. Also use the [Status] key to toggle single or double read-out mode.

[Quick Menu]

Allows quick set-up of the frequency converter. **The most common functions can be programmed here.**

The [Quick Menu] consists of:

- Q1: My Personal Menu
- Q2: Quick Setup
- Q3: Function Setups
- Q5: Changes Made
- Q6: Loggings

The Function set-up provides quick and easy access to all parameters required for the majority of water and wastewater applications including variable torque, constant torque, pumps, dosing pumps, well pumps, booster pumps, mixer pumps, aeration blowers and other pump and fan applications. Amongst other features it also includes parameters for selecting which variables to display on the LCP, digital preset speeds, scaling of analog references, closed loop single zone and multi-zone applications and specific functions related to water and wastewater applications.

The Quick Menu parameters can be accessed immediately unless a password has been created via par. 0-60, 0-61, 0-65 or 0-66.

It is possible to switch directly between Quick Menu mode and Main Menu mode.

[Main Menu]

is used for programming all parameters.

The Main Menu parameters can be accessed immediately unless a password has been created via par. 0-60, 0-61, 0-65 or 0-66. For the majority of water and wastewater applications it is not necessary to access the Main Menu parameters but instead the Quick Menu, Quick Setup and Function Setups provides the simplest and quickest access to the typical required parameters.

It is possible to switch directly between Main Menu mode and Quick Menu mode.

Parameter shortcut can be carried out by pressing down the [Main Menu] key for 3 seconds. The parameter shortcut allows direct access to any parameter.

[Alarm Log]

displays an Alarm list of the five latest alarms (numbered A1-A5). To obtain additional details about an alarm, use the arrow keys to manoeuvre to the alarm number and press [OK]. Information is displayed about the condition of the frequency converter before it enters the alarm mode.

[Back]

reverts to the previous step or layer in the navigation structure.

[Cancel]

last change or command will be cancelled as long as the display has not been changed.

[Info]

displays information about a command, parameter, or function in any display window. [Info] provides detailed information when needed.

Exit Info mode by pressing either [Info], [Back], or [Cancel].



Navigation Keys

The four navigation arrows are used to navigate between the different choices available in [Quick Menu], [Main Menu] and [Alarm Log]. Use the keys to move the cursor.

[OK]

is used for choosing a parameter marked by the cursor and for enabling the change of a parameter.



Operation Keys

for local control are found at the bottom of the control panel.



[Hand On]

enables control of the frequency converter via the GLCP. [Hand on] also starts the motor, and it is now possible to give the motor speed reference by means of the arrow keys. The key can be *Enabled* [1] or *Disabled* [0] via par. 0-40 [Hand on] Key on LCP.

The following control signals will still be active when [Hand on] is activated:

- [Hand on] - [Off] - [Auto on]
- Reset
- Coasting stop inverse (motor coasting to stop)
- Reversing
- Set-up select lsb - Set-up select msb
- Stop command from serial communication
- Quick stop
- DC brake

NB!
External stop signals activated by means of control signals or a serial bus will override a "start" command via the LCP.

[Off]

stops the connected motor. The key can be *Enabled* [1] or *Disabled* [0] via par. 0-41 [Off] key on LCP. If no external stop function is selected and the [Off] key is inactive the motor can only be stopped by disconnecting the mains supply.

[Auto On]

enables the frequency converter to be controlled via the control terminals and/or serial communication. When a start signal is applied on the control terminals and/or the bus, the frequency converter will start. The key can be *Enabled* [1] or *Disabled* [0] via par. 0-42 [Auto on] key on LCP.

NB!
An active HAND-OFF-AUTO signal via the digital inputs has higher priority than the control keys [Hand on] – [Auto on].

[Reset]

is used for resetting the frequency converter after an alarm (trip). The key can be *Enabled* [1] or *Disabled* [0] via par. 0-43 Reset Keys on LCP.

The parameter shortcut

can be carried out by holding down the [Main Menu] key for 3 seconds. The parameter shortcut allows direct access to any parameter.

7.1.3. How to operate numeric LCP (NLCP)

The following instructions are valid for the NLCP (LCP 101).

The control panel is divided into four functional groups:

1. Numeric display.
2. Menu key and indicator lights (LEDs) - changing parameters and switching between display functions.
3. Navigation keys and indicator lights (LEDs).
4. Operation keys and indicator lights (LEDs).

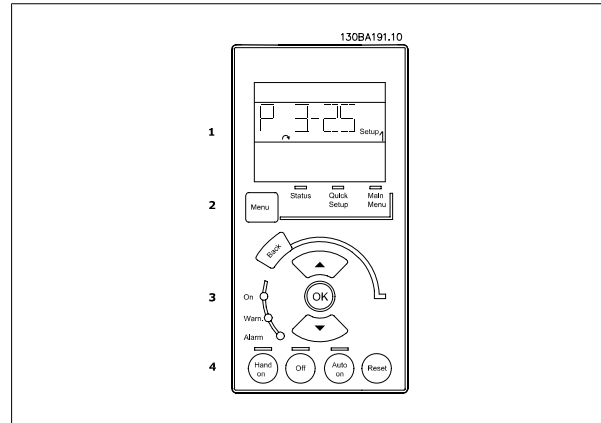
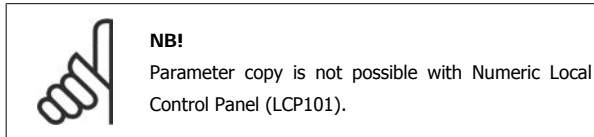

Illustration 7.1: Numerical LCP (NLCP)

Select one of the following modes:

Status Mode: Displays the status of the drive or the motor.

If an alarm occurs, the NLCP automatically switches to status mode.

A number of alarms can be displayed.

Quick Setup or Main Menu Mode: Display parameters and parameter settings.

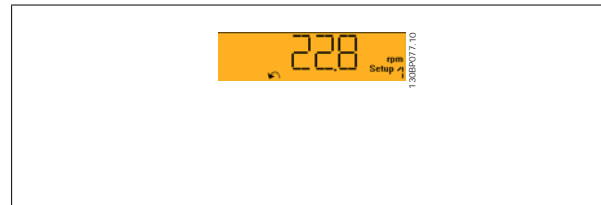

Illustration 7.2: Status display example



Illustration 7.3: Alarm display example

Indicator lights (LEDs):

- Green LED/On: Indicates if control section is on.
- Yellow LED/Wrn.: Indicates a warning.
- Flashing red LED/Alarm: Indicates an alarm.

Menu key

[Menu] Select one of the following modes:

- Status
- Quick Setup
- Main Menu

Main Menu

is used for programming all parameters.

The parameters can be accessed immediately unless a password has been created via par. 0-60, par. 0-61, par. 0-65 or par. 0-66.

Quick Setup is used to set up the drive using only the most essential parameters.

The parameter values can be changed using the up/down arrows when the value is flashing.

Select Main Menu by pressing the [Menu] key a number of times until the Main Menu LED is lit.

Select the parameter group [xx-__] and press [OK]

Select the parameter [__-xx] and press [OK]

If the parameter is an array parameter select the array number and press [OK]

Select the wanted data value and press [OK]

Navigation Keys

[Back]

for stepping backwards

Arrow [▲] [▼]

keys are used for manoeuvring between parameter groups, parameters and within parameters

[OK]

is used for choosing a parameter marked by the cursor and for enabling the change of a parameter.

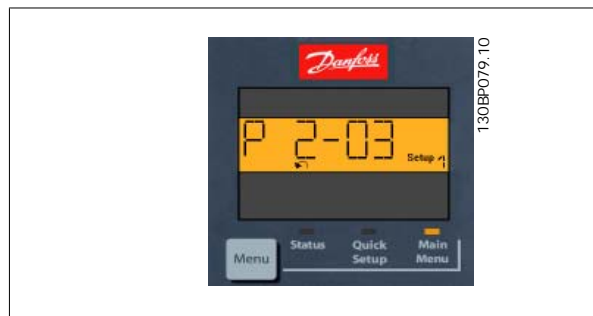

Illustration 7.4: Display example

Operation Keys

Keys for local control are found at the bottom of the control panel.



Illustration 7.5: Operation keys of the numerical CP (NLCP)

[Hand on]

enables control of the drive via the LCP. [Hand on] also starts the motor and it is now possible to enter the motor speed data by means of the arrow keys. The key can be *Enabled* [1] or *Disabled* [0] via par. 0-40 *[Hand on] Key on LCP*.

External stop signals activated by means of control signals or a serial bus will override a 'start' command via the LCP.

The following control signals will still be active when [Hand on] is activated:

- [Hand on] - [Off] - [Auto on]
- Reset
- Coasting stop inverse
- Reversing
- Set-up select lsb - Set-up select msb
- Stop command from serial communication
- Quick stop
- DC brake

[Off]

stops the connected motor. The key can be *Enabled* [1] or *Disabled* [0] via par. 0-41 *[Off] Key on LCP*.

If no external stop function is selected and the [Off] key is inactive the motor can be stopped by disconnecting the mains supply.

[Auto on]

enables the drive to be controlled via the control terminals and/or serial communication. When a start signal is applied on the control terminals and/or the bus, the drive will start. The key can be *Enabled* [1] or *Disabled* [0] via par. 0-42 *[Auto on] Key on LCP*.

NB!
An active HAND-OFF-AUTO signal via the digital inputs has higher priority than the control keys [Hand on] [Auto on].

[Reset]

is used for resetting the drive after an alarm (trip). The key can be *Enabled* [1] or *Disabled* [0] via par. 0-43 *Reset Keys on LCP*.

7.1.4. Changing Data

1. Press [Quick Menu] or [Main Menu] key.
2. Use [▲] and [▼] keys to find parameter group to edit.
3. Press [OK] key.
4. Use [▲] and [▼] keys to find parameter to edit.
5. Press [OK] key.
6. Use [▲] and [▼] keys to select correct parameter setting. Or, to move to digits within a number, use keys. Cursor indicates digit selected to change. [▲] key increases the value, [▼] key decreases the value.
7. Press [Cancel] key to disregard change, or press [OK] key to accept change and enter new setting.

7.1.5. Changing a Text Value

If the selected parameter is a text value, change the text value by means of the up/down navigation keys.

The up key increases the value, and the down key decreases the value.

Place the cursor on the value to be saved and press [OK].

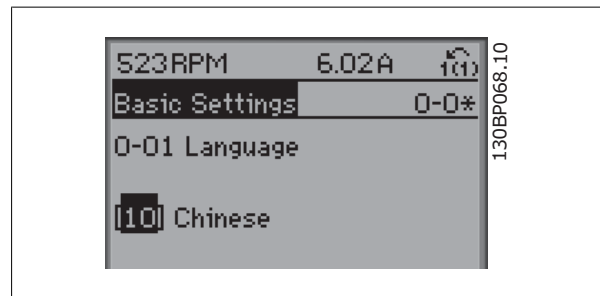

Illustration 7.6: Display example.

7.1.6. Changing a Group of Numeric Data Values

If the chosen parameter represents a numeric data value, change the chosen data value by means of the <> navigation keys as well as the up/down navigation keys. Use the <> navigation keys to move the cursor horizontally.

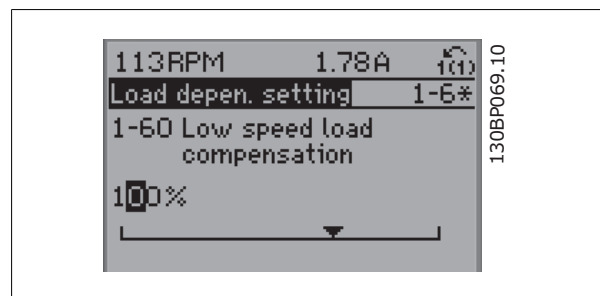

Illustration 7.7: Display example.

Use the up/down navigation keys to change the data value. The up key enlarges the data value, and the down key reduces the data value. Place the cursor on the value to be saved and press [OK].

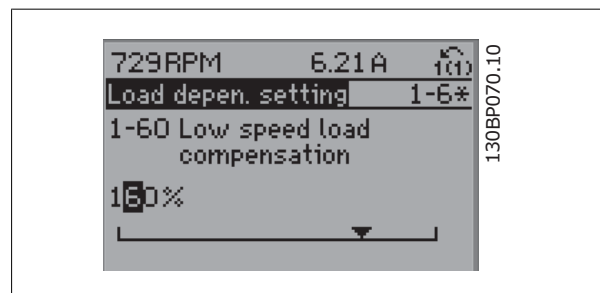

Illustration 7.8: Display example.

7.1.7. Changing of Data Value, Step-by-Step

Certain parameters can be changed step by step or infinitely variably. This applies to *Motor Power* (par. 1-20), *Motor Voltage* (par. 1-22) and *Motor Frequency* (par. 1-23).

The parameters are changed both as a group of numeric data values and as numeric data values infinitely variably.

7.1.8. Read-out and Programming of Indexed Parameters

Parameters are indexed when placed in a rolling stack.

Par. 15-30 to par. 15-32 contain a fault log which can be read out. Choose a parameter, press [OK], and use the up/down navigation keys to scroll through the value log.

Use par. 3-10 as another example:

Choose the parameter, press [OK], and use the up/down navigation keys to scroll through the indexed values. To change the parameter value, select the indexed value and press [OK]. Change the value by using the up/down keys. Press [OK] to accept the new setting. Press [Cancel] to abort. Press [Back] to leave the parameter.

7.1.9. Tips and tricks

*	For the majority of water and wastewater applications the Quick Menu, Quick Setup and Function Setups provides the simplest and quickest access to all the typical parameters required.
*	Whenever possible, performing an AMA, will ensure best shaft performance
*	Contrast of the display can be adjusted by pressing [Status] and [▲] for darker display or by pressing [Status] and [▼] for brighter display
*	Under [Quick Menu] and [Changes Made] all parameters that have been changed from factory settings are displayed
*	Press and hold [Main Menu] key for 3 seconds for access to any parameter
*	For service purposes it is recommended to copy all parameters to the LCP, see par 0-50 for further information

Table 7.1: Tips and tricks

7.1.10. Quick Transfer of Parameter Settings when using GLCP

Once the set-up of a frequency converter is complete, it is recommended to store (backup) the parameter settings in the GLCP or on a PC via MCT 10 Set-up Software Tool.

NB!
Stop the motor before performing any of these operations.

Data storage in LCP:

1. Go to par. 0-50 *LCP Copy*
2. Press the [OK] key
3. Select "All to LCP"
4. Press the [OK] key

All parameter settings are now stored in the GLCP indicated by the progress bar. When 100% is reached, press [OK].

The GLCP can now be connected to another frequency converter and the parameter settings copied to this frequency converter.

Data transfer from LCP to Frequency converter:

1. Go to par. 0-50 *LCP Copy*
2. Press the [OK] key
3. Select "All from LCP"
4. Press the [OK] key

The parameter settings stored in the GLCP are now transferred to the frequency converter indicated by the progress bar. When 100% is reached, press [OK].

7.1.11. Initialisation to Default Settings

There are two ways to initialise the frequency converter to default: Recommended initialisation and manual initialisation. Please be aware that they have different impact according to the below description.

Recommended initialisation (via par. 14-22)

1. Select par. 14-22
2. Press [OK]
3. Select "Initialisation" (for NLCP select "2")
4. Press [OK]
5. Remove power to unit and wait for display to turn off.
6. Reconnect power and the frequency converter is reset. Note that first start-up takes a few more seconds.
7. Press [Reset]

Par. 14-22 initialises all except:	
Par. 14-50	RFI 1
Par. 8-30	Protocol
Par. 8-31	Address
Par. 8-32	Baud Rate
Par. 8-35	Minimum Response Delay
Par. 8-36	Max Response Delay
Par. 8-37	Max Inter-char Delay
Par. 15-00 to par. 15-05	Operating data
Par. 15-20 to par. 15-22	Historic log
Par. 15-30 to par. 15-32	Fault log



NB!
Parameters selected in *Personal Menu*, will stay present, with default factory setting.

Manual initialisation



NB!
When carrying out manual initialisation, serial communication, RFI filter settings (par. 14-50) and fault log settings are reset. Removes parameters selected in *Personal Menu*.

1. Disconnect from mains and wait until the display turns off.
- 2a. Press [Status] - [Main Menu] - [OK] at the same time while power up for Graphical LCP (GLCP).
- 2b. Press [Menu] while power up for LCP 101, Numerical Display
3. Release the keys after 5 s.
4. The frequency converter is now programmed according to default settings.

This parameter initialises all except:	
15-00	Operating Hours
15-03	Power-up's
15-04	Over temp's
15-05	Over volt's

7.1.12. RS-485 Bus Connection

One or more frequency converters can be connected to a controller (or master) using the RS-485 standard interface. Terminal 68 is connected to the P signal (TX+, RX+), while terminal 69 is connected to the N signal (TX-,RX-).

If more than one frequency converter is connected to a master, use parallel connections.

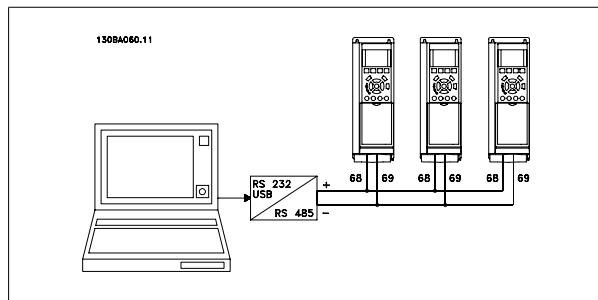

Illustration 7.9: Connection example.

In order to avoid potential equalizing currents in the screen, earth the cable screen via terminal 61, which is connected to the frame via an RC-link.

Bus termination

The RS-485 bus must be terminated by a resistor network at both ends. If the drive is the first or the last device in the RS-485 loop, set the switch S801 on the control card for ON.

For more information, see the paragraph *Switches S201, S202, and S801*.

7.1.13. How to Connect a PC to the Frequency Converter

To control or programme the frequency converter from a PC, install the MCT 10 Set-up software on the computer.

The PC is connected via a standard (host/device) USB cable, or via the RS-485 interface as shown in the VLT® AQUA Drive FC 200 Design Guide chapter *How to Install > Installation of misc. connections*.

 **NB!**
The USB connection is galvanically isolated from the supply voltage (PELV) and other high-voltage terminals. The USB connection is connected to protection earth on the frequency converter. Use only isolated laptop as PC connection to the USB connector on the frequency converter.

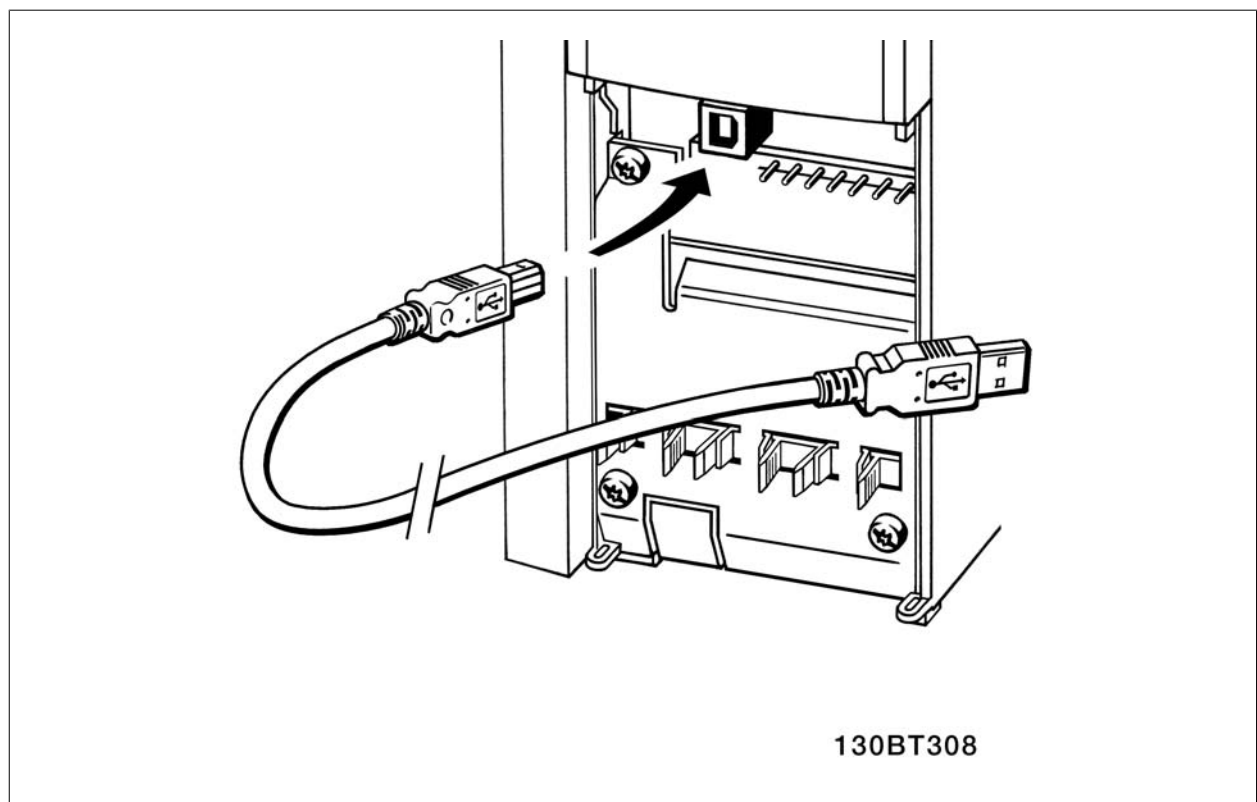

Illustration 7.10: USB Connection

7.1.14. PC Software tools

PC Software - MCT 10

All Frequency converters are equipped with a serial communication port. Danfoss provides a PC tool for communication between PC and frequency converter, VLT Motion Control Tool MCT 10 Set-up Software.

MCT 10 Set-up Software

MCT 10 has been designed as an easy to use interactive tool for setting parameters in our frequency converters. The software can be downloaded from the Danfoss internet site <http://www.vlt-software.com>.

The MCT 10 Set-up Software will be useful for:

- Planning a communication network off-line. MCT 10 contains a complete frequency converter database
- Commissioning frequency converters on line
- Saving settings for all frequency converters
- Replacing a frequency converter in a network
- Simple and accurate documentation of frequency converter settings after commissioning.
- Expanding an existing network
- Future developed frequency converters will be supported

MCT 10 Set-up Software supports Profibus DP-V1 via a Master class 2 connection. It makes it possible to on line read/write parameters on-line in a frequency converter via the Profibus network. This will eliminate the need for an extra communication network.

Save Frequency Converter Settings:

1. Connect a PC to the unit via USB com port. (Note: Use a PC, which is isolated from the mains, in conjunction with the USB port. Failure to do so may damage equipment.)
2. Open MCT 10 Set-up Software
3. Choose "Read from drive"
4. Choose "Save as"

All parameters are now stored in the PC.

Load Frequency Converter Settings:

1. Connect a PC to the frequency converter via USB com port
2. Open MCT 10 Set-up software
3. Choose "Open"– stored files will be shown
4. Open the appropriate file
5. Choose "Write to drive"

All parameter settings are now transferred to the frequency converter.

A separate manual for MCT 10 Set-up Software is available: **MG.10.R2.02**.

The MCT 10 Set-up Software Modules

The following modules are included in the software package:

	MCT 10 Set-up Software Setting parameters Copy to and from frequency converters Documentation and print out of parameter settings incl. diagrams
	Ext. User Interface Preventive Maintenance Schedule Clock settings Timed Action Programming Smart Logic Controller Set-up Cascade Control Config. Tool

Ordering number:

Please order the CD containing MCT 10 Set-up Software using code number 130B1000.

MCT 10 can also be downloaded from the Danfoss Internet: WWW.DANFOSS.COM, Business Area: Motion Controls.

8. How to programme the frequency converter

8.1. How to programme

8.1.1. Parameter Set-Up

Overview of parameter groups

Group	Title	Function
0-	Operation / Display	Parameters related to the fundamental functions of the frequency converter, function of the LCP buttons and configuration of the LCP display.
1-	Load / Motor	Parameter group for motor settings.
2-	Brakes	Parameter group for setting brake features in the frequency converter.
3-	Reference / Ramps	Parameters for reference handling, definitions of limitations, and configuration of the reaction of the frequency converter to changes.
4-	Limits / Warnings	Parameter group for configuring limits and warnings.
5-	Digital In/Out	Parameter group for configuring the digital inputs and outputs.
6-	Analog In/Out	Parameter group for configuration of the analog inputs and outputs.
8-	Communication and Options	Parameter group for configuring communications and options.
9-	Profibus	Parameter group for Profibus-specific parameters.
10-	DeviceNet Fieldbus	Parameter group for DeviceNet-specific parameters.
11-	LonWorks	Parameter group for LonWorks parameters
13-	Smart Logic	Parameter group for Smart Logic Control
14-	Special Functions	Parameter group for configuring special frequency converter functions.
15-	Drive Information	Parameter group containing frequency converter information such as operating data, hardware configuration and software versions.
16-	Data Readouts	Parameter group for data read-outs, e.g. actual references, voltages, control, alarm, warning and status words.
18-	Info and Readouts	This parameter group contains the last 10 Preventive Maintenance logs.
20-	Drive Closed Loop	This parameter group is used for configuring the closed loop PID Controller that controls the output frequency of the unit.
21-	Extended Closed Loop	Parameters for configuring the three Extended Closed Loop PID Controllers.
22-	Application Functions	These parameters monitor water applications.
23-	Time-based Functions	These parameters are for actions needed to be performed on a daily or weekly basis, e.g. different references for working hours/non-working hours.
25-	Basic Cascade Controller Functions	Parameters for configuring the Basic Cascade Controller for sequence control of multiple pumps.
26-	Analog I/O Option MCB 109	Parameters for configuring the Analog I/O Option MCB 109.
27-	Extended Cascade Control	Parameters for configuring the Extended Cascade Control.
29-	Water Application Functions	Parameters for setting water specific functions.
31-	Bypass Option	Parameters for configuring the Bypass Option

Table 8.1: Parameter Groups

Parameter descriptions and selections are displayed on the graphic (GLCP) or numeric (NLCP) in the display area. (See Section 5 for details.) Access the parameters by pressing the [Quick Menu] or [Main Menu] key on the control panel. The quick menu is used primarily for commissioning the unit at start-up by providing those parameters necessary to start operation. The main menu provides access to all parameters for detailed application programming.

All digital input/output and analog input/output terminals are multifunctional. All terminals have factory default functions suitable for the majority of water applications but if other special functions are required, they must be programmed in parameter group 5 or 6.

8.1.2. Quick Menu Mode

The GLCP provides access to all parameters listed under the Quick Menu. To set parameters using the [Quick Menu] button:

Pressing [Quick Menu] the list indicates the different areas contained in the Quick menu.

Efficient Parameter Set-up for Water Applications

The parameters can easily be set up for the vast majority of the water and wastewater applications only by using the [Quick Menu].

The optimum way to set parameters through the [Quick Menu] is by following the below steps:

1. Press [Quick Setup] for selecting basic motor settings, ramp times, etc.
2. Press [Function Setups] for setting up the required functionality of the frequency converter - if not already covered by the settings in [Quick Setup].
3. Choose between *General Settings*, *Open Loop Settings* and *Closed Loop Settings*.

It is recommended to do the set-up in the order listed.

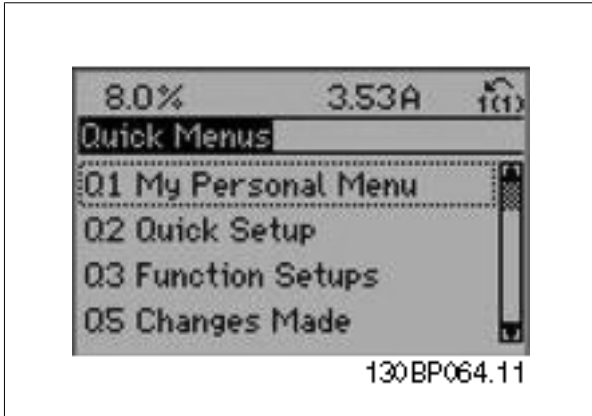

Illustration 8.1: Quick menu view.

Par.	Designation	[Units]
0-01	Language	
1-20	Motor Power	[kW]
1-22	Motor Voltage	[V]
1-23	Motor Frequency	[Hz]
1-24	Motor Current	[A]
1-25	Motor Nominal Speed	[RPM]
3-41	Ramp 1 Ramp up Time	[s]
3-42	Ramp 1 Ramp down Time	[s]
4-11	Motor Speed Low Limit	[RPM]
4-13	Motor Speed Low High	[RPM]
1-29	Automatic Motor Adaption	[AMA]

Table 8.2: Quick Setup parameters

If *No Operation* is selected in terminal 27 no connection to +24 V on terminal 27 is necessary to enable start.

If *Coast Inverse* (factory default value) is selected in Terminal 27, a connection to +24V is necessary to enable start.

8.1.3. Q1 My Personal Menu

Parameters defined by the user can be stored in Q1 My Personal Menu.

Select *My Personal Menu* to display only the parameters, which have been pre-selected and programmed as personal parameters. For example, a pump or equipment OEM may have pre-programmed these to be in My Personal Menu during factory commissioning to make on site commissioning / fine tuning simpler.. These parameters are selected in par. 0-25 *My Personal Menu*. Up to 20 different parameters can be defined in this menu.

Q1 My Personal Menu	
20-21	Setpoint 1
20-93	PID Proportional Gain
20-94	PID Integral Time

8.1.4. Q2 Quick Setup

The parameters in Q2 Quick Setup are the basic parameters which are always needed to set-up the frequency converter to operation.

Q2 Quick Setup	
Parameter number and name	Unit
0-01	Language
1-20	Motor Power
1-22	Motor Voltage
1-23	Motor Frequency
1-24	Motor Current
1-25	Motor Nominal Speed
3-41	Ramp 1 Ramp Up Time
3-42	Ramp 1 Ramp Down Time
4-11	Motor Speed Low Limit
4-13	Motor Speed High Limit
1-29	Automatic Motor Adaptation (AMA)

8.1.5. Q3 Function Setups

The Function Setup provides quick and easy access to all parameters required for the majority of water and wastewater applications including variable torque, constant torque, pumps, dosing pumps, well pumps, booster pumps, mixer pumps, aeration blowers and other pump and fan applications. Amongst other features it also includes parameters for selecting which variables to display on the LCP, digital preset speeds, scaling of analog references, closed loop single zone and multi-zone applications and specific functions related to water and wastewater applications.

How to access Function Set-up - example

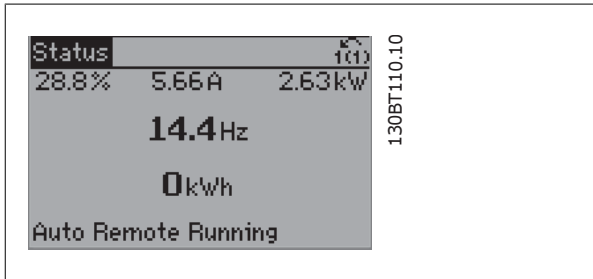

Illustration 8.2: Step 1: Turn on the frequency converter (On LED lights)

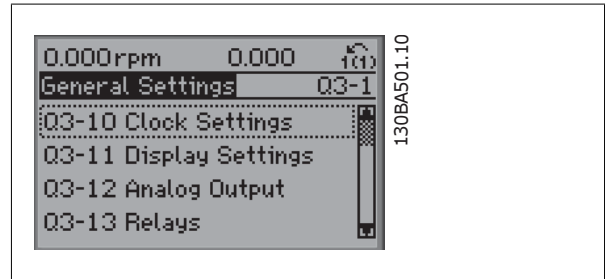

Illustration 8.6: Step 5: Use the up/down navigation keys to scroll down to i.e. Q3-12 *Analog Outputs*. Press [OK].

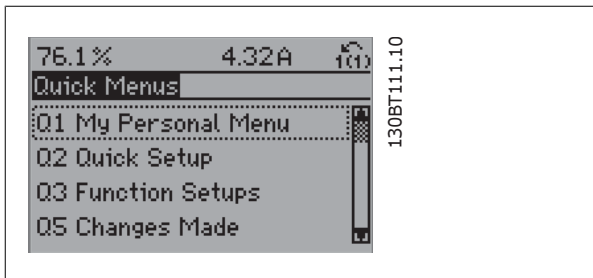

Illustration 8.3: Step 2: Press the [Quick Menus] button (Quick Menu choices appear).

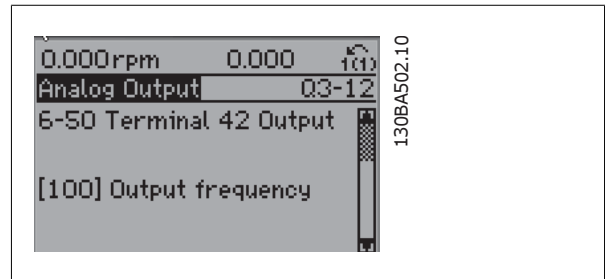

Illustration 8.7: Step 6: Choose parameter 6-50 *Terminal 42 Output*. Press [OK].

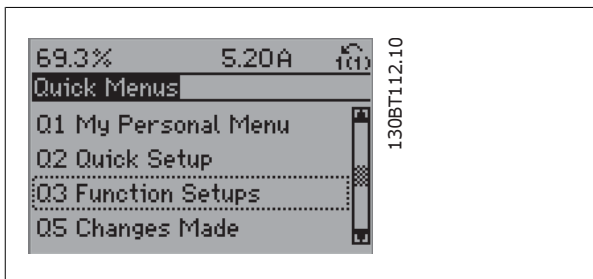

Illustration 8.4: Step 3: Use the up/down navigation keys to scroll down to Function Setups. Press [OK].

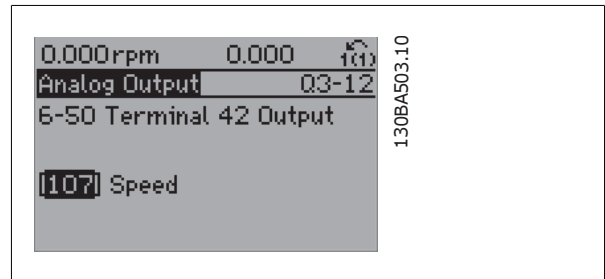

Illustration 8.8: Step 7: Use the up/down navigation keys to select between the different choices. Press [OK].

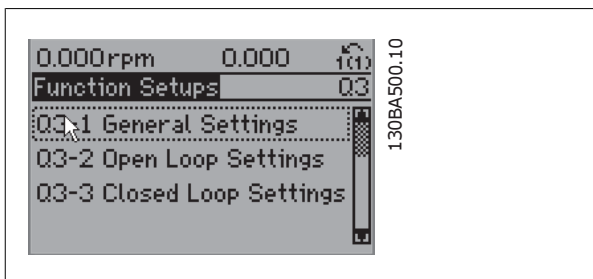

Illustration 8.5: Step 4: Function Setups choices appear. Choose Q3-1 *General Settings*. Press [OK].

The Function Setup parameters are grouped in the following way:

Q3-1 General Settings			
Q3-10 Clock Settings	Q3-11 Display Settings	Q3-12 Analog Output	Q3-13 Relays
0-70 Set Date and Time	0-20 Display Line 1.1 Small	6-50 Terminal 42 Output	Relay 1 ⇒ 5-40 Function Relay
0-71 Date Format	0-21 Display Line 1.2 Small	6-51 Terminal 42 Output Min Scale	Relay 2 ⇒ 5-40 Function Relay
0-72 Time Format	0-22 Display Line 1.3 Small	6-52 Terminal 42 Output Max Scale	Option relay 7 ⇒ 5-40 Function Relay
0-74 DST/Summertime	0-23 Display Line 2 Large		Option relay 8 ⇒ 5-40 Function Relay
0-76 DST/Summertime Start	0-24 Display Line 3 Large		Option relay 9 ⇒ 5-40 Function Relay
0-77 DST/Summertime End	0-37 Display Text 1		
	0-38 Display Text 2		
	0-39 Display Text 3		

Q3-2 Open Loop Settings	
Q3-20 Digital Reference	Q3-21 Analog Reference
3-02 Minimum Reference	3-02 Minimum Reference
3-03 Maximum Reference	3-03 Maximum Reference
3-10 Preset Reference	6-10 Terminal 53 Low Voltage
5-13 Terminal 29 Digital Input	6-11 Terminal 53 High Voltage
5-14 Terminal 32 Digital Input	6-14 Terminal 53 Low Ref/Feedb. Value
5-15 Terminal 33 Digital Input	6-15 Terminal 53 High Ref/Feedb. Value

Q3-3 Closed Loop Settings	
Q3-30 Feedback Settings	Q3-31 PID Settings
1-00 Configuration Mode	20-81 PID Normal/Inverse Control
20-12 Reference/Feedb.Unit	20-82 PID Start Speed [RPM]
3-02 Minimum Reference	20-21 Setpoint 1
3-03 Maximum Reference	20-93 PID Proportional Gain
6-20 Terminal 54 Low Voltage	20-94 PID Integral Time
6-21 Terminal 54 High Voltage	
6-24 Terminal 54 Low Ref/Feedb Value	
6-25 Terminal 54 High Ref/Feedb Value	
6-00 Live Zero Timeout Time	
6-01 Live Zero Timeout Function	

8.1.6. Q5 Changes Made

Q5 Changes Made can be used for fault finding.

Select **Changes made** to get information about:

- the last 10 changes. Use the up/down navigation keys to scroll between the last 10 changed parameters.
- the changes made since default setting.

Select **Loggings** to get information about the display line read-outs. The information is shown as graphs.

Only display parameters selected in par. 0-20 and par. 0-24 can be viewed. It is possible to store up to 120 samples in the memory for later reference.

Please notice that the parameters listed in the below tables for Q5 only serve as examples as they will vary depending on the programming of the particular frequency converter.

Q5-1 Last 10 Changes	
20-94 PID Integral Time	
20-93 PID Proportional Gain	

Q5-2 Since Factory Setting	
20-93 PID Proportional Gain	
20-94 PID Integral Time	

Q5-3 Input Assignments	
Analog Input 53	
Analog Input 54	

8.1.7. Q6 Loggings

Q6 Loggings can be used for fault finding.

Please notice that the parameters listed in the below table for Q6 only serve as examples as they will vary depending on the programming of the particular frequency converter.

Q6 Loggings	
Reference	
Analog Input 53	
Motor Current	
Frequency	
Feedback	
Energy Log	
Trending Cont Bin	
Trending Timed Bin	
Trending Comparison	

8.1.8. Main Menu Mode

Both the GLCP and NLCP provide access to the main menu mode. Select the Main Menu mode by pressing the [Main Menu] key. Illustration 6.2 shows the resulting read-out, which appears on the display of the GLCP. Lines 2 through 5 on the display show a list of parameter groups which can be chosen by toggling the up and down buttons.

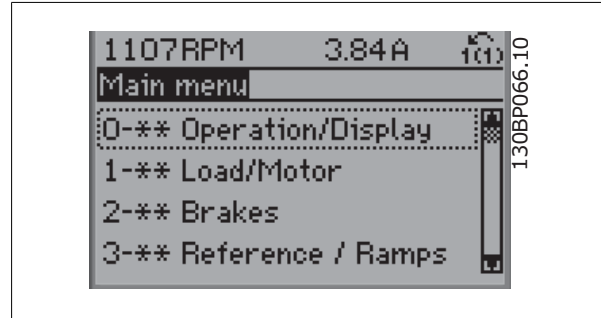

Illustration 8.9: Display example.

Each parameter has a name and number which remain the same regardless of the programming mode. In the Main Menu mode, the parameters are divided into groups. The first digit of the parameter number (from the left) indicates the parameter group number.

All parameters can be changed in the Main Menu. The configuration of the unit (par.1-00) will determine other parameters available for programming. For example, selecting Closed Loop enables additional parameters related to closed loop operation. Option cards added to the unit enable additional parameters associated with the option device.

8.1.9. Parameter Selection

In the Main Menu mode, the parameters are divided into groups. Select a parameter group by means of the navigation keys. The following parameter groups are accessible:

Group no.	Parameter group:
0	Operation/Display
1	Load/Motor
2	Brakes
3	References/Ramps
4	Limits/Warnings
5	Digital In/Out
6	Analog In/Out
8	Comm. and Options
9	Profibus
10	CAN Fieldbus
11	LonWorks
13	Smart Logic
14	Special Functions
15	Drive Information
16	Data Readouts
18	Data Readouts 2
20	Drive Closed Loop
21	Ext. Closed Loop
22	Application Functions
23	Time-based Functions
24	Fire Mode
25	Cascade Controller
26	Analog I/O Option MCB 109

Table 8.3: Parameter groups.

[1115]	LON Warning Word	Shows the LON-specific warnings.
[1117]	XIF Revision	Shows the version of the external interface file of the Neuron C chip on the LON option.
[1118]	LON Works Revision	Shows the software version of the application program of the Neuron C chip on the LON option.
[1501]	Running Hours	View the number of running hours of the motor.
[1502]	kWh Counter	View the mains power consumption in kWh.
[1600]	Control Word	View the Control Word sent from the frequency converter via the serial communication port in hex code.
[1601] *	Reference [Unit]	Total reference (sum of digital/analog/preset/bus/freeze ref./catch up and slow-down) in selected unit.
[1602]	Reference %	Total reference (sum of digital/analog/preset/bus/freeze ref./catch up and slow-down) in percent.
[1603]	Status Word	Present status word
[1605]	Main Actual Value [%]	One or more warnings in a Hex code
[1609]	Custom Readout	View the user-defined readouts as defined in par. 0-30, 0-31 and 0-32.
[1610]	Power [kW]	Actual power consumed by the motor in kW.
[1611]	Power [hp]	Actual power consumed by the motor in HP.
[1612]	Motor Voltage	Voltage supplied to the motor.
[1613]	Motor Frequency	Motor frequency, i.e. the output frequency from the frequency converter in Hz.
[1614]	Motor Current	Phase current of the motor measured as effective value.
[1615]	Frequency [%]	Motor frequency, i.e. the output frequency from the frequency converter in percent.
[1616]	Torque [Nm]	Present motor load as a percentage of the rated motor torque.
[1617]	Speed [RPM]	Speed in RPM (revolutions per minute) i.e. the motor shaft speed in closed loop based on the entered motor nameplate data, the output frequency and the load on the frequency converter.
[1618]	Motor Thermal	Thermal load on the motor, calculated by the ETR function. See also parameter group 1-9* Motor Temperature.
[1622]	Torque [%]	Shows the actual torque produced, in percentage.
[1630]	DC Link Voltage	Intermediate circuit voltage in the frequency converter.
[1632]	BrakeEnergy/s	Present brake power transferred to an external brake resistor. Stated as an instantaneous value.
[1633]	BrakeEnergy/2 min	Brake power transferred to an external brake resistor. The mean power is calculated continuously for the most recent 120 seconds.
[1634]	Heatsink Temp.	Present heat sink temperature of the frequency converter. The cut-out limit is 95 ±5 °C; cutting back in occurs at 70 ±5° C.
[1635]	Thermal Drive Load	Percentage load of the inverters
[1636]	Inv. Nom. Current	Nominal current of the frequency converter
[1637]	Inv. Max. Current	Maximum current of the frequency converter
[1638]	SL Control State	State of the event executed by the control
[1639]	Control Card Temp.	Temperature of the control card.
[1650]	External Reference	Sum of the external reference as a percentage, i.e. the sum of analog/pulse/bus.
[1652]	Feedback [Unit]	Signal value in units from the programmed digital input(s).
[1653]	Digi Pot Reference	View the contribution of the digital potentiometer to the actual reference Feedback.
[1654]	Feedback 1 [Unit]	View the value of Feedback 1. See also par. 20-0*.
[1655]	Feedback 2 [Unit]	View the value of Feedback 2. See also par. 20-0*.
[1656]	Feedback 3 [Unit]	View the value of Feedback 3. See also par. 20-0*.
[1660]	Digital Input	Displays the status of the 6 digital input terminals (18, 19, 27, 29, 32 and 33). Input 18 corresponds to the bit at the far left. Signal low = 0; Signal high = 1
[1661]	Terminal 53 Switch Setting	Setting of input terminal 53. Current = 0; Voltage = 1.
[1662]	Analog Input 53	Actual value at input 53 either as a reference or protection value.
[1663]	Terminal 54 Switch Setting	Setting of input terminal 54. Current = 0; Voltage = 1.
[1664]	Analog Input 54	Actual value at input 54 either as reference or protection value.

[1665]	Analog Output 42 [mA]	Actual value at output 42 in mA. Use par. 6-50 to select the variable to be represented by output 42.
[1666]	Digital Output [bin]	Binary value of all digital outputs.
[1667]	Freq. Input #29 [Hz]	Actual value of the frequency applied at terminal 29 as a pulse input.
[1668]	Freq. Input #33 [Hz]	Actual value of the frequency applied at terminal 33 as a pulse input.
[1669]	Pulse Output #27 [Hz]	Actual value of pulses applied to terminal 27 in digital output mode.
[1670]	Pulse Output #29 [Hz]	Actual value of pulses applied to terminal 29 in digital output mode.
[1671]	Relay Output [bin]	View the setting of all relays.
[1672]	Counter A	View the present value of Counter A.
[1673]	Counter B	View the present value of Counter B.
[1675]	Analog input X30/11	Actual value of the signal on input X30/11 (General Purpose I/O Card. Option)
[1676]	Analog input X30/12	Actual value of the signal on input X30/12 (General Purpose I/O Card. Optional)
[1677]	Analog output X30/8 [mA]	Actual value at output X30/8 (General Purpose I/O Card. Optional) Use Par. 6-60 to select the variable to be shown.
[1680]	Fieldbus CTW 1	Control word (CTW) received from the Bus Master.
[1682]	Fieldbus REF 1	Main reference value sent with control word via the serial communications network e.g. from the BMS, PLC or other master controller.
[1684]	Comm. Option STW	Extended fieldbus communication option status word.
[1685]	FC Port CTW 1	Control word (CTW) received from the Bus Master.
[1686]	FC Port REF 1	Status word (STW) sent to the Bus Master.
[1690]	Alarm Word	One or more alarms in a Hex code (used for serial communications)
[1691]	Alarm Word 2	One or more alarms in a Hex code (used for serial communications)
[1692]	Warning Word	One or more warnings in a Hex code (used for serial communications)
[1693]	Warning Word 2	One or more warnings in a Hex code (used for serial communications)
[1694]	Ext. Status Word	One or more status conditions in a Hex code (used for serial communications)
[1695]	Ext. Status Word 2	One or more status conditions in a Hex code (used for serial communications)
[1696]	Maintenance Word	The bits reflect the status for the programmed Preventive Maintenance Events in parameter group 23-1*
[1830]	Analog Input X42/1	Shows the value of the signal applied to terminal X42/1 on the Analog I/O card.
[1831]	Analog Input X42/3	Shows the value of the signal applied to terminal X42/3 on the Analog I/O card.
[1832]	Analog Input X42/5	Shows the value of the signal applied to terminal X42/5 on the Analog I/O card.
[1833]	Analog Out X42/7 [V]	Shows the value of the signal applied to terminal X42/7 on the Analog I/O card.
[1834]	Analog Out X42/9 [V]	Shows the value of the signal applied to terminal X42/9 on the Analog I/O card.
[1835]	Analog Out X42/11 [V]	Shows the value of the signal applied to terminal X42/11 on the Analog I/O card.
[2117]	Ext. 1 Reference [Unit]	The value of the reference for extended Closed Loop Controller 1
[2118]	Ext. 1 Feedback [Unit]	The value of the feedback signal for extended Closed Loop Controller 1
[2119]	Ext. 1 Output [%]	The value of the output from extended Closed Loop Controller 1
[2137]	Ext. 2 Reference [Unit]	The value of the reference for extended Closed Loop Controller 2
[2138]	Ext. 2 Feedback [Unit]	The value of the feedback signal for extended Closed Loop Controller 2
[2139]	Ext. 2 Output [%]	The value of the output from extended Closed Loop Controller 2
[2157]	Ext. 3 Reference [Unit]	The value of the reference for extended Closed Loop Controller 3
[2158]	Ext. 3 Feedback [Unit]	The value of the feedback signal for extended Closed Loop Controller 3
[2159]	Ext. Output [%]	The value of the output from extended Closed Loop Controller 3
[2230]	No-Flow Power	The calculated No Flow Power for the actual operating speed
[2580]	Cascade Status	Status for the operation of the Cascade Controller
[2581]	Pump Status	Status for the operation of each individual pump controlled by the Cascade Controller

**NB!**

Please consult the VLT® AQUA Drive Programming Guide, MG.20.OX.YY for detailed information.

0-21 Display Line 1.2 Small**Option:****Function:**

Select a variable for display in line 1, middle position.

[1662] * Analog input 53

The options are the same as those listed for par. 0-20 *Display Line 1.1 Small*.

0-22 Display Line 1.3 Small**Option:****Function:**

Select a variable for display in line 1, right position.

[1614] * Motor Current

The options are the same as those listed for par. 0-20 *Display Line 1.1 Small*.

0-23 Display Line 2 Large**Option:****Function:**

Select a variable for display in line 2. The options are the same as those listed for par. 0-20 *Display Line 1.1 Small*.

[1615] * Frequency

0-24 Display Line 3 Large**Option:****Function:**

[1652] * Feedback [Unit]

Select a variable for display in line 2. The options are the same as those listed for par. 0-20 *Display Line 1.1 Small*.

0-37 Display Text 1**Option:****Function:**

In this parameter it is possible to write an individual text string for display in the LCP or to be read via serial communication. If to be displayed permanently select Display Text 1 in par. 0-20, par. 0-21, par. 0-22, par. 0-23 or par. 0-24, *Display Line XXX*. Use the ▲ or ▼ buttons on the LCP to change a character. Use the ◀ and ▶ buttons to move the cursor. When a character is highlighted by the cursor, it can be changed. Use the ▲ or ▼ buttons on the LCP to change a character. A character can be inserted by placing the cursor between two characters and pressing ▲ or ▼.

0-38 Display Text 2**Option:****Function:**

In this parameter it is possible to write an individual text string for display in the LCP or to be read via serial communication. If to be displayed permanently select Display Text 2 in par. 0-20, par. 0-21, par. 0-22, par. 0-23 or par. 0-24, *Display Line XXX*. Use the ▲ or ▼ buttons on the LCP to change a character. Use the ◀ and ▶ buttons to move the cursor. When a character is highlighted by the cursor, this character can be changed. A character can be inserted by placing the cursor between two characters and pressing ▲ or ▼.

0-39 Display Text 3**Option:****Function:**

In this parameter it is possible to write an individual text string for display in the LCP or to be read via serial communication. If to be displayed permanently select Display Text 3 in par. 0-20, par. 0-21, par. 0-22, par. 0-23

or par. 0-24, *Display Line XXX*. Use the ▲ or ▼ buttons on the LCP to change a character. Use the ◀ and ▶ buttons to move the cursor. When a character is highlighted by the cursor, this character can be changed. A character can be inserted by placing the cursor between two characters and pressing ▲ or ▼.

0-70 Set Date and Time

Range:

2000-01-01 00:00 – 2099-12-01
23:59 * [2000-01-01 00:00]

Function:

Sets the date and time of the internal clock. The format to be used is set in par. 0-71 and 0-72.



NB!

This parameter does not display the actual time. This can be read in par. 0-89. The clock will not begin counting until a setting different from default has been made.

0-71 Date Format

Option:

[0] * YYYY-MM-DD

[1] DD-MM-YYYY

[2] MM/DD/YYYY

Function:

Sets the date format to be used in the LCP.

Sets the date format to be used in the LCP.

Sets the date format to be used in the LCP.

0-72 Time Format

Option:

[0] * 24 H

[1] 12 H

Function:

Sets the time format to be used in the LCP.

0-74 DST/Summertime

Option:

[0] * OFF

[2] Manual

Function:

Choose how Daylight Saving Time/Summertime should be handled. For manual DST/Summertime enter the start date and end date in par. 0-76 and par. 0-77.

0-76 DST/Summertime Start

Range:

2000-01-01 00:00* [2000-01-01
00:00 – 2099-12-31 23:59]

Function:

Sets the date and time when summertime/DST starts. The date is programmed in the format selected in par. 0-71.

0-77 DST/Summertime End

Range:

2000-01-01 00:00* [2000-01-01
00:00 – 2099-12-31 23:59]

Function:

Sets the date and time when summertime/DST ends. The date is programmed in the format selected in par. 0-71.

8.2.3. General Settings, 1-0*

Define whether the frequency converter operates in open loop or closed loop.

1-00 Configuration Mode

Option:

[0] * Open loop

Function:

Motor speed is determined by applying a speed reference or by setting desired speed when in Hand Mode. Open Loop is also used if the frequency converter is part of a closed loop control system based on an external PID controller providing a speed reference signal as output.

[3]	Closed loop	Motor Speed will be determined by a reference from the built-in PID controller varying the motor speed as part of a closed loop control process (e.g. constant pressure or flow). The PID controller must be configured in par. 20-** Drive Closed Loop or via the Function Setups accessed by pressing the [Quick Menus] button.
-----	-------------	---

This parameter can not be changed when motor is running.

**NB!**

When set for Closed Loop, the commands Reversing and Start Reversing will not reverse the direction of the motor.

1-20 Motor Power [kW]

Range:

Size related* [0.09 - 1200 kW]

Function:

Enter the nominal motor power in kW according to the motor nameplate data. The default value corresponds to the nominal rated output of the unit.

This parameter cannot be adjusted while the motor is running. Depending on the choices made in par. 0-03 *Regional Settings*, either par. 1-20 or par. 1-21 *Motor Power* is made invisible.

1-22 Motor Voltage

Range:

Size related* [10 - 1000 V]

Function:

Enter the nominal motor voltage according to the motor nameplate data. The default value corresponds to the nominal rated output of the unit.

This parameter cannot be adjusted while the motor is running.

1-23 Motor Frequency

Range:

Size related* [20 - 1000 Hz]

Function:

Select the motor frequency value from the motor nameplate data. For 87 Hz operation with 230/400 V motors, set the nameplate data for 230 V/50 Hz. Adapt par. 4-13 *Motor Speed High Limit [RPM]* and par. 3-03 *Maximum Reference* to the 87 Hz application.

This parameter cannot be adjusted while the motor is running.

1-24 Motor Current

Range:

Size related* [0.1 - 10000 A]

Function:

Enter the nominal motor current value from the motor nameplate data. This data is used for calculating motor torque, motor thermal protection etc.

This parameter cannot be adjusted while the motor is running.

1-25 Motor Nominal Speed

Range:

Size related* [100 - 60,000 RPM]

Function:

Enter the nominal motor speed value from the motor nameplate data. This data is used for calculating automatic motor compensations.

This parameter cannot be adjusted while the motor is running.

1-29 Automatic Motor Adaptation (AMA)

Option:

[0] * OFF

Function:

The AMA function optimizes dynamic motor performance by automatically optimizing the advanced motor parameters (par. 1-30 to par. 1-35) while the motor is stationary.

No function

- | | | |
|-----|---------------------|--|
| [1] | Enable complete AMA | performs AMA of the stator resistance R_s , the rotor resistance R_r , the stator leakage reactance X_{1l} , the rotor leakage reactance X_{2l} and the main reactance X_h . |
| [2] | Enable reduced AMA | performs a reduced AMA of the stator resistance R_s in the system only. Select this option if an LC filter is used between the frequency converter and the motor. |

Activate the AMA function by pressing [Hand on] after selecting [1] or [2]. See also the section *Automatic Motor Adaptation*. After a normal sequence, the display will read: "Press [OK] to finish AMA". After pressing the [OK] key the frequency converter is ready for operation.

Note:

- For the best adaptation of the frequency converter, run AMA on a cold motor.
- AMA cannot be performed while the motor is spinning.

NB!
It is important to set motor par. 1-2* Motor Data correctly, since these form part of the AMA algorithm. An AMA must be performed to achieve optimum dynamic motor performance. It may take up to 10 min, depending on the power rating of the motor.

NB!
Avoid generating external torque during AMA.

NB!
If one of the settings in par. 1-2* Motor Data is changed, par. 1-30 to par. 1-39, the advanced motor parameters, will return to default setting.
This parameter cannot be adjusted while the motor is running.

See section *Automatic Motor Adaptation* - application example.

8.2.4. 3-0* Reference Limits

Parameters for setting the reference unit, limits and ranges.

3-02 Minimum Reference

Range:	Function:
0.000 Unit* [-100000.000 – par. 3-03]	Enter the Minimum Reference. The Minimum Reference is the lowest value obtainable by summing all references.

3-03 Maximum Reference

Option:	Function:
[0.000 Unit] Par. 3-02 - 100000.000*	Enter the Maximum Reference. The Maximum Reference is the highest value obtainable by summing all references.

3-10 Preset Reference

Array [8]

0.00%* [-100.00 - 100.00 %]	Enter up to eight different preset references (0-7) in this parameter, using array programming. The preset reference is stated as a percentage of the value Ref _{MAX} (par. 3-03 <i>Maximum Reference</i>) or as a percentage of the other external references. If a Ref _{MIN} different from 0 (Par. 3-02 <i>Minimum Reference</i>) is programmed, the preset reference is calculated as a percentage of the full reference range, i.e. on the basis of the difference between Ref _{MAX} and Ref _{MIN} . Afterwards, the value is added to Ref _{MIN} . When using preset references, select Preset ref. bit 0 / 1 / 2 [16], [17] or [18] for the corresponding digital inputs in parameter group 5.1* Digital Inputs.
-----------------------------	---

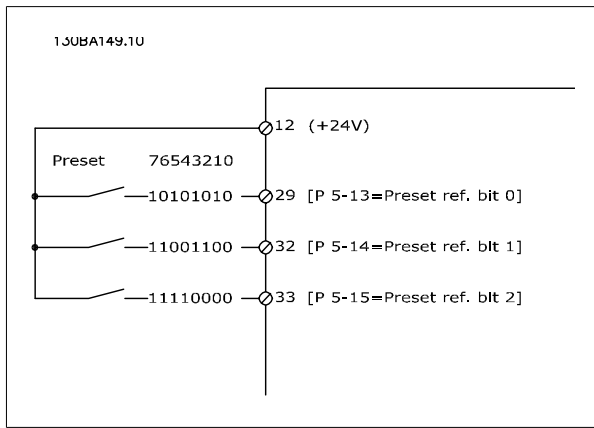

3-41 Ramp 1 Ramp up Time

Range:

10 s* [1 - 3600 s]

Function:

Enter the ramp-up time, i.e. the acceleration time from 0 RPM to the rated motor speed $n_{M,N}$ (par. 1-25). Choose a ramp-up time such that the output current does not exceed the current limit in par. 4-18 during ramping. See ramp-down time in par. 3-42.

$$par.3 - 41 = \frac{t_{acc} \times n_{norm} [par.1 - 25]}{\Delta ref [rpm]} [s]$$

See drawing above!

3-42 Ramp 1 Ramp Down Time

Range:

20 s* [1 - 3600 s]

Function:

Enter the ramp-down time, i.e. the deceleration time from the rated motor speed $n_{M,N}$ (par. 1-25) to 0 RPM. Choose a ramp-down time such that no over-voltage arises in the inverter due to regenerative operation of the motor, and such that the generated current does not exceed the current limit set in par. 4-18. See ramp-up time in par. 3-41.

$$par.3 - 42 = \frac{t_{dec} \times n_{norm} [par.1 - 25]}{\Delta ref [rpm]} [s]$$

3-84 Initial Ramp Time

Range:

0(off)* [0(off) – 60s]

Function:

Enter the initial ramp up time from 0rpm to minimum reference. Some pump applications have a requirement for different ramp rates when operating below the motor speed low limit. Initial ramp can be used as a faster ramp rate to quickly bring the up to speed from stopped to prevent damage to its thrust bearings. When P3-84 is different from 0s the initial ramp time will be used instead of the existing Ramp Up Time (P3-41 or P3-51).

3-85 Check Valve Ramp Time

Range:

0(off)* [0(off) – 60s]

Function:

To control the Check Valve closure to prevent water hammering this parameter can be used to set a ramp down time from motor speed low limit to Check Valve Ramp End Speed (P3-86 or P3-87) When P3-85 is different from 0.00 the Check valve Ramp Time is in effect and will be used to ramp down the speed from motor speed low limit to the Check Valve stop speed set in P3-86 or P3-87.

3-86 Check Valve Ramp End Speed [RPM]

Range:

Motor Speed Low Limit* [0 – Motor Speed Low Limit]

Function:

Set the speed in RPM below motor speed low limit where the Check Valve Ramp Time will no longer be used.

3-87 Check Valve Ramp End Speed [Hz]

Range:

Motor Speed Low Limit* [0 – Motor Speed Low Limit]

Function:

Set the speed in Hz below motor speed low limit where the Check Valve Ramp Time will no longer be used.

3-88 Final Ramp Time

Range:

0(off)* [0(off) – 60s]

Function:

Set the Final Ramp Down Time to be used when ramping down from Check Valve Ramp End Speed and 0 RPM. Final Ramp Down Time can be used as a quick ramp down time to prevent damage of pumps with thrust bearings. When Final Ramp Time is in effect the Final Ramp will be used instead of the existing ramp down time (P3-42 or P3-52)

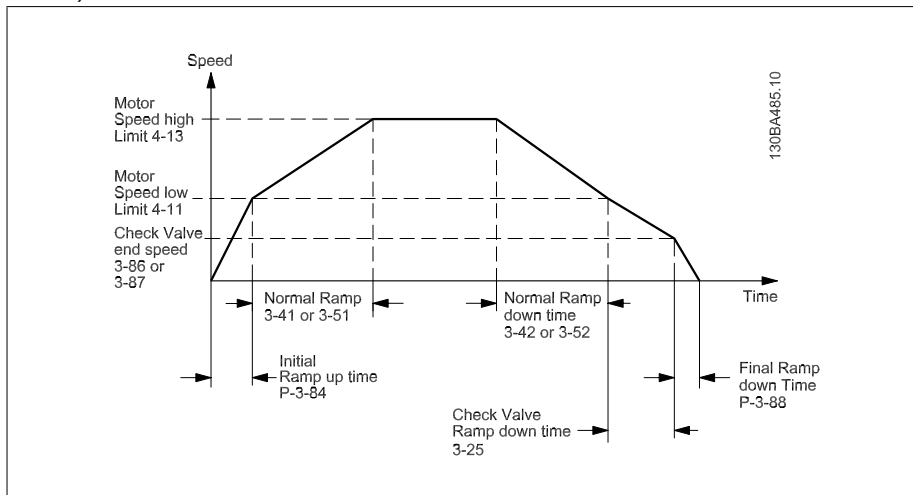

8.2.5. 4-** Limits and Warnings

Parameter group for configuring limits and warnings.



4-11 Motor Speed Low Limit [RPM]

Range:

Size related* [0 - 60,000 RPM]

Function:

Enter the minimum limit for motor speed. The Motor Speed Low Limit can be set to correspond to the manufacturer's recommended minimum motor speed. The Motor Speed Low Limit must not exceed the setting in par. 4-13 *Motor Speed High Limit [RPM]*.

4-13 Motor Speed High Limit [RPM]

Range:

Size related* [0 - 60,000 RPM]

Function:

Enter the maximum limit for motor speed. The Motor Speed High Limit can be set to correspond to the manufacturer's maximum rated motor speed. The Motor Speed High Limit must exceed the setting in par. 4-11 *Motor Speed Low Limit [RPM]*. Only par. 4-11 or par. 4-12 will be displayed depending on other parameters set in the Main Menu and depending on default settings dependant on global geographical location.

 **NB!**
The output frequency value of the frequency converter must not exceed a value higher than 1/10 of the switching frequency.

 **NB!**
Any changes in par. 4-13 will reset the value in par. 4-53 *Warning High Speed* to the same value as set in par. 4-13.

8.2.6. 5-** Digital In/Out

Parameter group for configuring the digital input and output.

8.2.7. 5-1* Digital Inputs

Parameters for configuring the input functions for the input terminals.

The digital inputs are used for selecting various functions in the frequency converter. All digital inputs can be set to the following functions:

Digital input function	Select	Terminal
No operation	[0]	All *term 32, 33
Reset	[1]	All
Coast inverse	[2]	All
Coast and reset inverse	[3]	All
DC-brake inverse	[5]	All
Stop inverse	[6]	All
External interlock	[7]	All
Start	[8]	All *term 18
Latched start	[9]	All
Reversing	[10]	All *term 19
Start reversing	[11]	All
Jog	[14]	All *term 29
Preset reference on	[15]	All
Preset ref bit 0	[16]	All
Preset ref bit 1	[17]	All
Preset ref bit 2	[18]	All
Freeze reference	[19]	All
Freeze output	[20]	All
Speed up	[21]	All
Speed down	[22]	All
Set-up select bit 0	[23]	All
Set-up select bit 1	[24]	All
Pulse input	[32]	term 29, 33
Ramp bit 0	[34]	All
Mains failure inverse	[36]	All
Run Permissive	[52]	
Hand start	[53]	
Auto start	[54]	
DigiPot Increase	[55]	All
DigiPot Decrease	[56]	All
DigiPot Clear	[57]	All
Counter A (up)	[60]	29, 33
Counter A (down)	[61]	29, 33
Reset Counter A	[62]	All
Counter B (up)	[63]	29, 33
Counter B (down)	[64]	29, 33
Reset Counter B	[65]	All
Sleep Mode	[66]	
Reset Maintenance Word	[78]	
Lead Pump Start	[120]	
Lead Pump Alternation	[121]	
Pump 1 Interlock	[130]	
Pump 2 Interlock	[131]	
Pump 3 Interlock	[132]	

All = Terminals 18, 19, 27, 29, 32, X30/2, X30/3, X30/4. X30/ are the terminals on MCB 101.

Functions dedicated to only one digital input are stated in the associated parameter.

All digital inputs can be programmed to these functions:

[0]	No operation	No reaction to signals transmitted to terminal.
[1]	Reset	Resets frequency converter after a TRIP/ALARM. Not all alarms can be reset.
[2]	Coast inverse	Leaves motor in free mode. Logic '0' => coasting stop. (Default Digital input 27): Coasting stop, inverted input (NC).
[3]	Coast and reset inverse	Reset and coasting stop Inverted input (NC). Leaves motor in free mode and resets the frequency converter. Logic '0' => coasting stop and reset.
[5]	DC-brake inverse	Inverted input for DC braking (NC). Stops motor by energizing it with a DC current for a certain time period. See par. 2-01 to par. 2-03. The function is only active when the value in par. 2-02 is different from 0. Logic '0' => DC braking.
[6]	Stop inverse	Stop Inverted function. Generates a stop function when the selected terminal goes from logical level '1' to '0'. The stop is performed according to the selected ramp time (par. 3-42, par. 3-52, par. 3-62, par. 3-72).



NB!

When the frequency converter is at the torque limit and has received a stop command, it may not stop by itself. To ensure that the frequency converter stops, configure a digital output to *Torque limit & stop* [27] and connect this digital output to a digital input that is configured as coast.

[7]	External Interlock	Same function as Coasting stop, inverse, but External Interlock generates the alarm message 'external fault' on the display when the terminal which is programmed for Coast Inverse is logic '0'. The alarm message will also be active via digital outputs and relay outputs, if programmed for External Interlock. The alarm can be reset using a digital input or the [RESET] key if the cause for the External Interlock has been removed. A delay can be programmed in par. 22-00, External Interlock Time. After applying a signal to the input, the reaction described above will be delayed with the time set in par. 22-00.
[8]	Start	Select start for a start/stop command. Logic '1' = start, logic '0' = stop. (Default Digital input 18)
[9]	Latched start	Motor starts, if a pulse is applied for min. 2 ms. Motor stops when Stop inverse is activated
[10]	Reversing	Changes direction of motor shaft rotation. Select Logic '1' to reverse. The reversing signal only changes the direction of rotation. It does not activate the start function. Select both directions in par. 4-10 <i>Motor Speed Direction</i> . (Default Digital input 19).
[11]	Start reversing	Used for start/stop and for reversing on the same wire. Signals on start are not allowed at the same time.
[14]	Jog	Used for activating jog speed. See par. 3-11. (Default Digital input 29)
[15]	Preset reference on	Used for shifting between external reference and preset reference. It is assumed that <i>External/preset</i> [1] has been selected in par. 3-04. Logic '0' = external reference active; logic '1' = one of the eight preset references is active.
[16]	Preset ref bit 0	Enables a choice between one of the eight preset references according to the table below.
[17]	Preset ref bit 1	Enables a choice between one of the eight preset references according to the table below.
[18]	Preset ref bit 2	Enables a choice between one of the eight preset references according to the table below.

Preset ref. bit	2	1	0
Preset ref. 0	0	0	0
Preset ref. 1	0	0	1
Preset ref. 2	0	1	0
Preset ref. 3	0	1	1
Preset ref. 4	1	0	0
Preset ref. 5	1	0	1
Preset ref. 6	1	1	0
Preset ref. 7	1	1	1

[19]	Freeze ref	Freezes actual reference. The frozen reference is now the point of enable/condition for Speed up and Speed down to be used. If Speed up/down is used, the speed change always follows ramp 2 (par. 3-51 and 3-52) in the range 0 - par. 3-03 <i>Maximum Reference</i> .
[20]	Freeze output	Freezes actual motor frequency (Hz). The frozen motor frequency is now the point of enable/condition for Speed up and Speed down to be used. If Speed up/down is used, the speed change always follows ramp 2 (par. 3-51 and 3-52) in the range 0 - par. 1-23 <i>Motor Frequency</i> .

NB!
When Freeze output is active, the frequency converter cannot be stopped via a low 'start [13]' signal. Stop the frequency converter via a terminal programmed for Coasting inverse [2] or Coast and reset, inverse [3].

[21]	Speed up	For digital control of the up/down speed is desired (motor potentiometer). Activate this function by selecting either Freeze reference or Freeze output. When Speed up is activated for less than 400 msec. the resulting reference will be increased by 0.1 %. If Speed up is activated for more than 400 msec. the resulting reference will ramp according to Ramp 1 in par. 3-41.
[22]	Speed down	Same as Speed up [21].
[23]	Set-up select bit 0	Selects one of the four set-ups. Set par. 0-10 <i>Active Set-up</i> to Multi Set-up.
[24]	Set-up select bit 1	Same as Set-up select bit 0 [23].

(Default Digital input 32)

[32]	Pulse input	Select Pulse input when using a pulse sequence as either reference or feedback. Scaling is done in par. group 5-5*.
[34]	Ramp bit 0	Select which ramp to use. Logic "0" will select ramp 1 while logic "1" will select ramp 2.
[36]	Mains failure inverse	Activates par. 14-10 <i>Mains Failure</i> . Mains failure inverse is active in the Logic "0" situation.
[52]	Run Permissive	The input terminal, for which the Run permissive has been programmed must be logic "1" before a start command can be accepted. Run permissive has a logic 'AND' function related to the terminal which is programmed for <i>START</i> [8], <i>Jog</i> [14] or <i>Freeze Output</i> [20], which means that in order to start running the motor, both conditions must be fulfilled. If Run Permissive is programmed on multiple terminals, Run permissive needs only be logic '1' on one of the terminals for the function to be carried out. The digital output signal for Run Request (<i>Start</i> [8], <i>Jog</i> [14] or <i>Freeze output</i> [20]) programmed in par. 5-3* Digital outputs, or par. 5-4* Relays, will not be affected by Run Permissive.
[53]	Hand start	A signal applied will put the frequency converter into Hand mode as if button <i>Hand On</i> on the LCP has been pressed and a normal stop command will be overridden. If disconnecting the signal, the motor will stop. To make any other start commands valid, another digital input must be assign to <i>Auto Start</i> and a signal applied to this. The <i>Hand On</i> and <i>Auto On</i> buttons on the LCP has no impact. The <i>Off</i> button on the LCP will override <i>Hand Start</i> and <i>Auto Start</i> . Press either the <i>Hand On</i> or <i>Auto On</i> button to make <i>Hand Start</i> and <i>Auto Start</i> active again. If no signal on neither <i>Hand Start</i> nor <i>Auto Start</i> , the motor will stop regardless of any normal Start command applied. If signal applied to both <i>Hand Start</i> and <i>Auto Start</i> , the function will be <i>Auto Start</i> . If pressing the <i>Off</i> button on the LCP the motor will stop regardless of signals on <i>Hand Start</i> and <i>Auto Start</i> .
[54]	Auto start	A signal applied will put the frequency converter into Auto mode as if the LCP button <i>Auto On</i> has been pressed. See also <i>Hand Start</i> [53]
[55]	DigiPot Increase	Uses the input as an INCREASE signal to the Digital Potentiometer function described in parameter group 3-9*
[56]	DigiPot Decrease	Uses the input as a DECREASE signal to the Digital Potentiometer function described in parameter group 3-9*
[57]	DigiPot Clear	Uses the input to CLEAR the Digital Potentiometer reference described in parameter group 3-9*
[60]	Counter A (up)	(Terminal 29 or 33 only) Input for increment counting in the SLC counter.
[61]	Counter A (down)	(Terminal 29 or 33 only) Input for decrement counting in the SLC counter.
[62]	Reset Counter A	Input for reset of counter A.
[63]	Counter B (up)	(Terminal 29 and 33 only) Input for increment counting in the SLC counter.
[64]	Counter B (down)	(Terminal 29 and 33 only) Input for decrement counting in the SLC counter.
[65]	Reset Counter B	Input for reset of counter B.
[66]	Sleep Mode	Forces frequency converter into Sleep Mode (see par. 22-4*, Sleep Mode). Reacts on the rising edge of signal applied!
[78]	Reset Preventive Maintenance Word	Resets all data in par. 16-96, Preventive Maintenance Word, to 0.

The below setting options are all related to the Cascade Controller. Wiring diagrams and settings for parameter, see group 25-** for more details.

[120]	Lead Pump Start	Starts/Stops the Lead Pump (controlled by the frequency converter). A start requires that also a System Start signal has been applied e.g. to one of the digital inputs set for <i>Start</i> [8]!
[121]	Lead Pump Alternation	Forces alternation of the lead pump in a Cascade Controller. <i>Lead Pump Alternation</i> , par. 25-50, must be set to either <i>At Command</i> [2] or <i>At Staging or At Command</i> [3]. <i>Alternation Event</i> , par. 25-51, can be set to any of the four options.
[130 - 138]	Pump1 Interlock Pump9 Interlock	- For the above 9 setting options, par. 25-10, Pump Interlock, must be set to <i>On</i> [1]. The function will also depend on the setting in par. 25-06, Fixed Lead Pump. If set to <i>No</i> [0], then Pump1 refers to the pump controlled by relay RELAY1 etc. If set to <i>Yes</i> [1], Pump1 refers to the pump controlled by the frequency converter only (without any of the build in relays involved) and Pump2 to the pump controlled by the relay RELAY1. Variable speed pump (lead) cannot be interlocked in the basic Cascade Controller. See below table:

Setting in Par. 5-1*	Setting in Par. 25-06	
	[0] No	[1] Yes
[130] Pump1 Interlock	Controlled by RELAY1 (only if not lead pump)	Frequency Converter controlled (cannot be interlocked)
[131] Pump2 Interlock	Controlled by RELAY2	Controlled by RELAY1
[132] Pump3 Interlock	Controlled by RELAY3	Controlled by RELAY2
[133] Pump4 Interlock	Controlled by RELAY4	Controlled by RELAY3
[134] Pump5 Interlock	Controlled by RELAY5	Controlled by RELAY4
[135] Pump6 Interlock	Controlled by RELAY6	Controlled by RELAY5
[136] Pump7 Interlock	Controlled by RELAY7	Controlled by RELAY6
[137] Pump8 Interlock	Controlled by RELAY8	Controlled by RELAY7
[138] Pump9 Interlock	Controlled by RELAY9	Controlled by RELAY8

5-13 Terminal 29 Digital Input

Option:

[0] * No Operation

Function:

Same options and functions as par. 5-1* *Digital Inputs*.

5-14 Terminal 32 Digital Input

Option:

[0] * No Operation

Function:

Same options and functions as par. 5-1* *Digital Inputs*, except for *Pulse input*.

5-15 Terminal 33 Digital Input

Option:

[0] * No Operation

Function:

Same options and functions as par. 5-1* *Digital Inputs*.

5-40 Function Relay

Array [8]	(Relay 1 [0], Relay 2 [1], Relay 7 [6], Relay 8 [7], Relay 9 [8])
-----------	---

Select options to define the function of the relays.
The selection of each mechanical relay is realised in an array parameter.

[0]	No Operation
[1]	Control Ready
[2]	Drive Ready
[3]	Drive Ready/Remote
[4]	Stand-by/No Warning
[5] *	Running
[6]	Running/No Warning
[8]	Run on Ref./No Warning
[9]	Alarm
[10]	Alarm or Warning
[11]	At Torque Limit
[12]	Out of Current Range
[13]	Below Current, low
[14]	Above Current, high
[15]	Out of Speed Range

[16]	Below Speed, low
[17]	Above Speed, high
[18]	Out of Feedb. Range
[19]	Below Feedback, low
[20]	Above Feedback, high
[21]	Thermal Warning
[25]	Reverse
[26]	Bus OK
[27]	Torque Limit & Stop
[28]	Brake, No Warning
[29]	Brake Ready, No Fault
[30]	Brake Fault (IGBT)
[35]	External Interlock
[36]	Control Word Bit 11
[37]	Control Word Bit 12
[40]	Out of Ref. Range
[41]	Below Reference, low
[42]	Above Ref. high
[45]	Bus ctrl
[46]	Bus ctrl, 1 if timeout
[47]	Bus ctrl, 0 if timeout
[60]	Comparator 0
[61]	Comparator 1
[62]	Comparator 2
[63]	Comparator 3
[64]	Comparator 4
[65]	Comparator 5
[70]	Logic Rule 0
[71]	Logic Rule 1
[72]	Logic Rule 2
[73]	Logic Rule 3
[74]	Logic Rule 4
[75]	Logic Rule 5
[80]	SL Digital Output A
[81]	SL Digital Output B
[82]	SL Digital Output C
[83]	SL Digital Output D
[84]	SL Digital Output E
[85]	SL Digital Output F
[160]	No Alarm
[161]	Running Reverse
[165]	Local Ref. Active
[166]	Remote Ref. Active
[167]	Start Cmd. Active
[168]	Drive in Hand Mode
[169]	Drive in Auto Mode
[180]	Clock Fault

[181]	Prev. Maintenance
[190]	No-Flow
[191]	Dry Pump
[192]	End of Curve
[193]	Sleep Mode
[194]	Broken Belt
[195]	Bypass Valve Control
[196]	Pipe Filling
[211]	Cascade Pump1
[212]	Cascade Pump2
[213]	Cascade Pump3
[223]	Alarm, Trip Locked
[224]	Bypass Mode Active

8.2.8. 6- ** Analog In/Out

Parameter group for configuration of the analog input and output.

6-00 Live Zero Timeout Time

Range:

10s* [1 - 99 s]

Function:

Enter the Live Zero Time-out time period. Live Zero Time-out Time is active for analog inputs, i.e. terminal 53 or terminal 54, allocated to current and used as reference or feedback sources. If the reference signal value associated with the selected current input falls below 50% of the value set in par. 6-10, par. 6-12, par. 6-20 or par. 6-22 for a time period longer than the time set in par. 6-00, the function selected in par. 6-01 will be activated.

6-01 Live Zero Timeout Function

Option:

Function:

Select the time-out function. The function set in par. 6-01 will be activated if the input signal on terminal 53 or 54 is below 50% of the value in par. 6-10, par. 6-12, par. 6-20 or par. 6-22 for a time period defined in par. 6-00. If several time-outs occur simultaneously, the frequency converter prioritises the time-out functions as follows:

1. Par. 6-01 *Live Zero Time-out Function*
2. Par. 8-04 *Control-word Time-out Function*

The output frequency of the frequency converter can be:

- [1] frozen at the present value
- [2] overruled to stop
- [3] overruled to jog speed
- [4] overruled to max. speed
- [5] overruled to stop with subsequent trip

If you select set-up 1-4, par. 0-10, *Active Set-up*, must be set to *Multi Set-up*, [9].

This parameter cannot be adjusted while the motor is running.

[0] *	Off
[1]	Freeze output
[2]	Stop
[3]	Jogging
[4]	Max. speed
[5]	Stop and trip

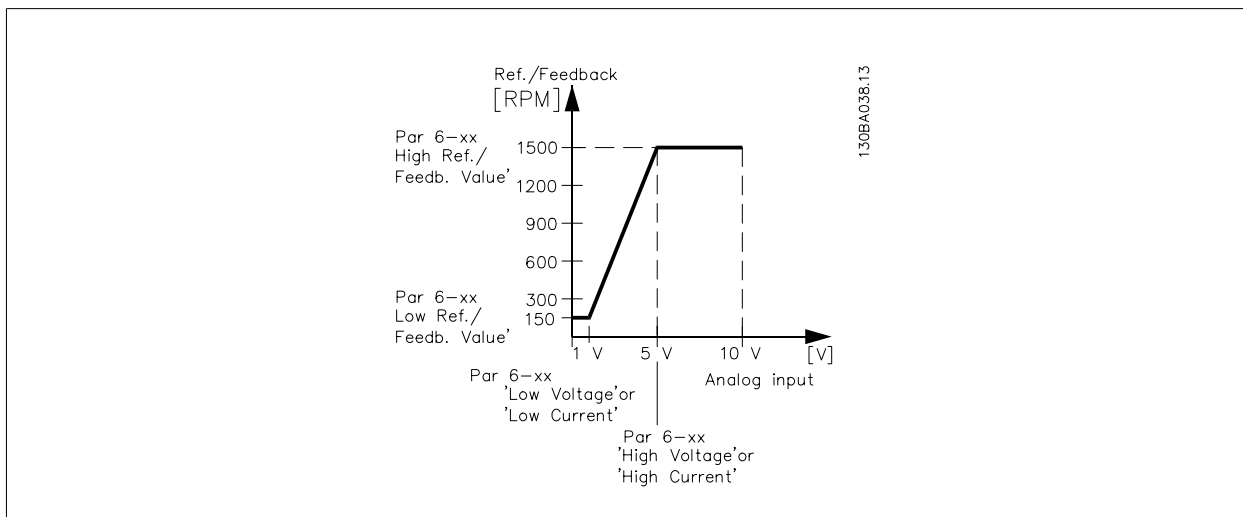

6-10 Terminal 53 Low Voltage

Range:

0.07V* [0.00 - par. 6-11]

Function:

Enter the low voltage value. This analog input scaling value should correspond to the low reference/feedback value set in par. 6-14.

6-11 Terminal 53 High Voltage

Range:

10.0V* [Par. 6-10 to 10.0 V]

Function:

Enter the high voltage value. This analog input scaling value should correspond to the high reference/feedback value set in par. 6-15.

6-14 Terminal 53 Low Ref./Feedb. Value

Range:

0.000 Unit* [-1000000.000 to par. 6-15]

Function:

Enter the analog input scaling value that corresponds to the low voltage/low current set in par. 6-10 and par. 6-12.

6-15 Terminal 53 High Ref./Feedb. Value

Range:

100.000 Unit* [Par. 6-14 to 1000000.000]

Function:

Enter the analog input scaling value that corresponds to the high voltage/high current value set in par. 6-11 and par. 6-13.

6-20 Terminal 54 Low Voltage

Range:

0.07V* [0.00 - par. 6-21]

Function:

Enter the low voltage value. This analog input scaling value should correspond to the low reference/feedback value, set in par. 6-24.

6-21 Terminal 54 High Voltage

Range:

10.0V* [Par. 6-20 to 10.0 V]

Function:

Enter the high voltage value. This analog input scaling value should correspond to the high reference/feedback value set in par. 6-25.

6-24 Terminal 54 Low Ref./Feedb. Value

Range:

0.000 Unit* [-1000000.000 to par. 6-25]

Function:

Enter the analog input scaling value that corresponds to the low voltage/low current value set in par. 6-20 and par. 6-22.

6-25 Terminal 54 high ref./feedb. value

Range:

100.000 Unit* [Par. 6-24 to 1000000.000]

Function:

Enter the analog input scaling value that corresponds to the high voltage/high current value set in par. 6-21 and par. 6-23.

6-50 Terminal 42 Output

Option:

Function:

Select the function of Terminal 42 as an analog current output.

[0]	No operation	
[100] *	Output frequency	: 0 - 100 Hz
[101]	Reference	: Minimum reference - Maximum reference
[102]	Feedback	: -200% to +200% of par. 2-14
[103]	Motor current	: 0 - Inverter Max. Current (par. 16-37)
[104]	Torque rel to lim	: 0 - Torque limit (par. 4-16)
[105]	Torque rel to rated	: 0 - Motor rated torque
[106]	Power	: 0 - Motor rated power
[107]	Speed	: 0 - Speed High Limit (par. 4-13 and par. 4-14)
[113]	Ext. closed loop 1	: 0 - 100%
[114]	Ext. closed loop 2	: 0 - 100%
[115]	Ext. closed loop 3	: 0 - 100%
[130]	Output freq. 4-20mA	:0 - 100 Hz
[131]	Reference 4-20mA	:Minimum Reference - Maximum Reference
[132]	Feedback 4-20mA	:-200% to +200% of par. 2-14
[133]	Motor cur. 4-20 mA	:0 - Inverter Max. Current (par. 16-37)
[134]	Torque % lim. 4-20 mA	:0 - Torque limit (par. 4-16)
[135]	Torque % nom 4-20 mA	:0 - Motor rated torque
[136]	Power 4-20 mA	:0 - Motor rated power
[137]	Speed 4-20 mA	:0 - Speed High Limit (par. 4-13 and par. 4-14)
[139]	Bus ctrl. 0-20 mA	:0 - 100%
[140]	Bus ctrl. 4-20 mA	: 0 - 100%
[141]	Bus ctrl. 0-20 mA, time-out	: 0 - 100%
[142]	Bus ctrl. 4-20 mA, time-out	: 0 - 100%
[143]	Ext. Closed Loop 1, 4-20 mA	: 0 - 100%
[144]	Ext. Closed Loop 2, 4-20 mA	: 0 - 100%
[145]	Ext. Closed Loop 3, 4-20 mA	: 0 - 100%

NB!

Values for setting the Minimum Reference is found in par. 3-02 *Open Loop* and par. 20-13 *Closed Loop* - values for Maximum Reference is found in par. 3-03 *Open Loop* and par. 20-14 *Closed Loop*.

6-51 Terminal 42 Output Min Scale

Range:

Function:

See the drawing below for details.

0%* [0 – 200%]

Scale for the minimum output (0 or 4 mA) of the selected analogue signal at terminal 42.
Set the value to be the **percentage** of the full scale value range of the variable selected in par. 6-50.

6-52 Terminal 42 Output Max Scale

Range:

Function:

Scale for the maximum output (20 mA) of the selected analog signal at terminal 42.

100%* [0 – 200%]

Set the value to be the percentage of the full scale value range of the variable selected in par. 6-50.

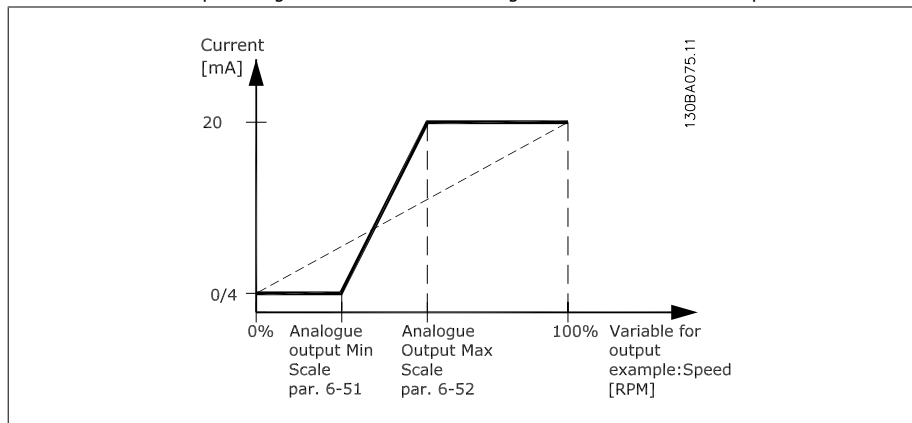

It is possible to get a value lower than 20 mA at full scale by programming values >100% by using a formula as follows:

$$20 \text{ mA} / \text{desired maximum current} \times 100 \%$$

$$\text{i.e. } 10 \text{ mA}: \frac{20 \text{ mA}}{10 \text{ mA}} \times 100 \% = 200 \%$$

(See example 3).

EXAMPLE 1:

Variable value= OUTPUT FREQUENCY, range= 0-100 Hz

Range needed for output= 0-50 Hz

Output signal 0 or 4 mA is needed at 0 Hz (0% of range) - set par. 6-51 to 0%

Output signal 20 mA is needed at 50 Hz (100% of range) - set par. 6-52 to 50%

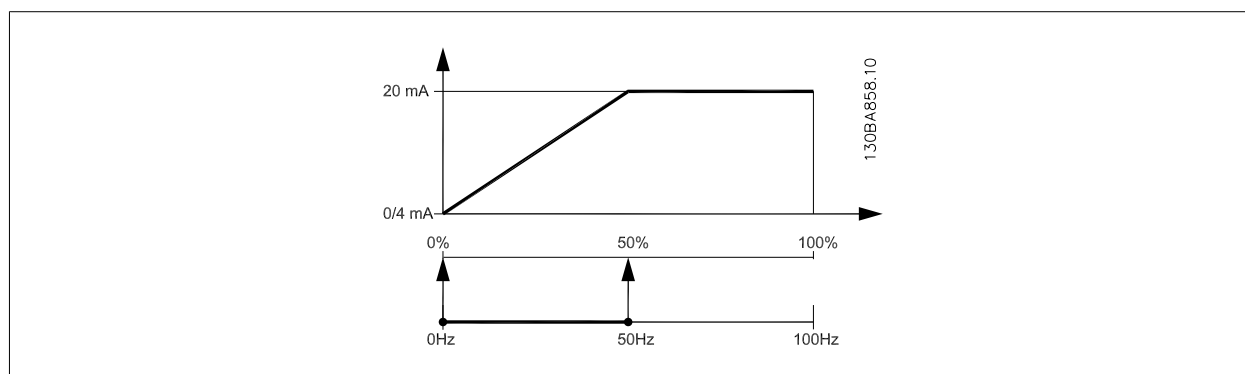

EXAMPLE 2:

Variable= FEEDBACK, range= -200% to +200%

Range needed for output= 0-100%

Output signal 0 or 4 mA is needed at 0% (50% of range) - set par. 6-51 to 50%

Output signal 20 mA is needed at 100% (75% of range) - set par. 6-52 to 75%

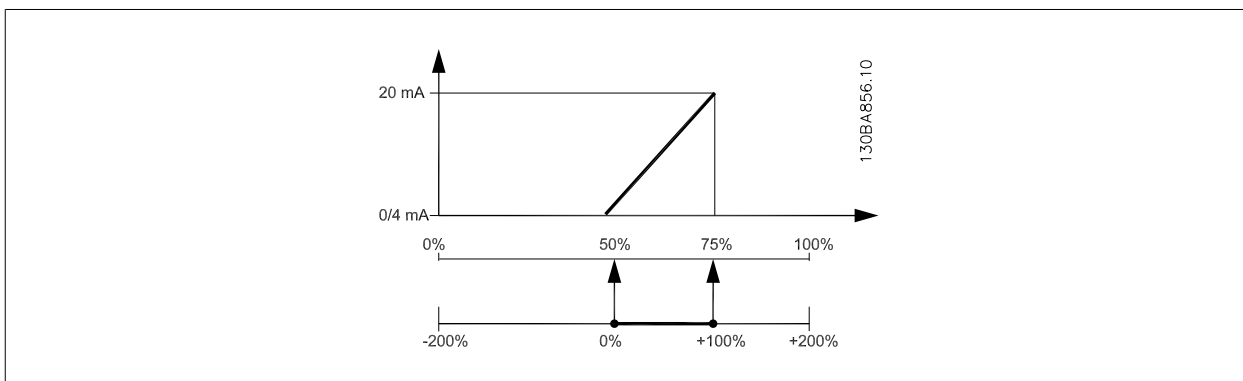

EXAMPLE 3:

Variable value= REFERENCE, range= Min ref - Max ref

Range needed for output= Min ref (0%) - Max ref (100%), 0-10 mA

Output signal 0 or 4 mA is needed at Min ref - set par. 6-51 to 0%

Output signal 10 mA is needed at Max ref (100% of range) - set par. 6-52 to 200%

(20 mA / 10 mA x 100%=200%).

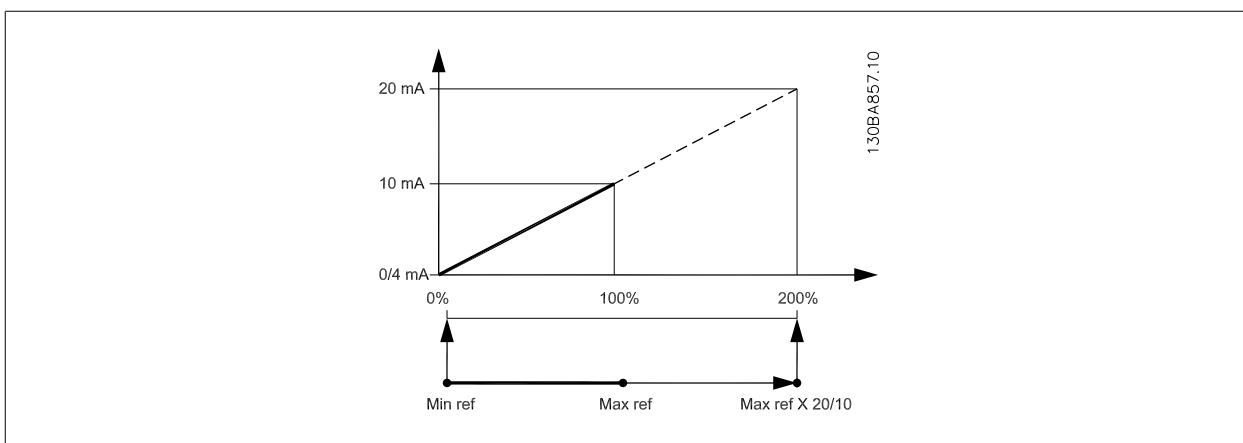

8.2.9. Drive Closed Loop, 20- **

This parameter group is used for configuring the closed loop PID Controller, that controls the output frequency of the frequency converter.

20-12 Reference/Feedback Unit

Option:

Function:

[0] None

[1] * %

[5] PPM

[10] 1/min

[11] RPM

[12] Pulse/s

[20] 1/s

[21]	l/min
[22]	l/h
[23]	m ³ /s
[24]	m ³ /min
[25]	m ³ /h
[30]	kg/s
[31]	kg/min
[32]	kg/h
[33]	t/min
[34]	t/h
[40]	m/s
[41]	m/min
[45]	m
[60]	°C
[70]	mbar
[71]	bar
[72]	Pa
[73]	kPa
[74]	m WG
[75]	mm Hg
[80]	kW
[120]	GPM
[121]	gal/s
[122]	gal/min
[123]	gal/h
[124]	CFM
[125]	ft ³ /s
[126]	ft ³ /min
[127]	ft ³ /h
[130]	lb/s
[131]	lb/min
[132]	lb/h
[140]	ft/s
[141]	ft/min
[145]	ft
[160]	°F
[170]	psi
[171]	lb/in ²
[172]	in WG
[173]	ft WG
[174]	in Hg
[180]	HP

This parameter determines the unit that is used for the setpoint reference and feedback that the PID Controller will use for controlling the output frequency of the frequency converter.

20-21 Setpoint 1

Range:

0.000* [Ref_{MIN} par.3-02 - Ref_{MAX} par. 3-03 UNIT (from par. 20-12)]

Function:

Setpoint 1 is used in Closed Loop Mode to enter a setpoint reference that is used by the frequency converter's PID Controller. See the description of *Feedback Function*, par. 20-20.



NB!

Setpoint reference entered here is added to any other references that are enabled (see par. group 3-1*).

20-81 PID Normal/Inverse Control

Option:

[0] * Normal

[1] Inverse

Function:

Normal [0] causes the frequency converter's output frequency to decrease when the feedback is greater than the setpoint reference. This is common for pressure-controlled supply fan and pump applications.

Inverse [1] causes the frequency converter's output frequency to increase when the feedback is greater than the setpoint reference.

20-82 PID Start Speed [RPM]

Range:

0* [0 - 6000 RPM]

Function:

When the frequency converter is first started, it initially ramps up to this output speed in Open Loop Mode, following the active Ramp Up Time. When the output speed programmed here is reached, the frequency converter will automatically switch to Closed Loop Mode and the PID Controller will begin to function. This is useful in applications in which the driven load must first quickly accelerate to a minimum speed when it is started.



NB!

This parameter will only be visible if par. 0-02 is set to [0], RPM.

20-93 PID Proportional Gain

Range:

0.50* [0.00 = Off - 10.00]

Function:

This parameter adjusts the output of the frequency converter's PID Controller based on the error between the feedback and the setpoint reference. Quick PID Controller response is obtained when this value is large. However, if too large a value is used, the frequency converter's output frequency may become unstable.

20-94 PID Integral Time

Range:

20.00 s* [0.01 - 10000.00 = Off s]

Function:

The integrator adds over time (integrates) the error between the feedback and the setpoint reference. This is required to ensure that the error approaches zero. Quick frequency converter speed adjustment is obtained when this value is small. However, if too small of a value is used, the frequency converter's output frequency may become unstable.

8.2.10. 22-** Miscellaneous

This group contains parameters used for monitoring water/ wastewater applications.

22-20 Low Power Auto Set-up

Option:

Function:

When set for *Enabled*, an auto set up sequence is activated, automatically setting speed to approx. 50 and 85% of rated motor speed (par. 4-13/14, *Motor Speed High Limit*). At those two speeds, the power consumption is automatically measured and stored.

Before enabling Auto Set Up:

22-26 Dry Pump Function

Option:

Function:

Low Power Detection must be Enabled (par. 22-21) and commissioned (using either par. 22-3*, *No Flow Power Tuning*, or par. 22-20 *Auto Set-Up*) in order to use Dry Pump Detection.

[0] * Off

[1] Warning Messages in the Local Control Panel display (if mounted) and/or signal via a relay or a digital output.

[2] Alarm The frequency converter trips and motor stays stopped until reset.

22-27 Dry Pump Delay

Range:

60 sec.* [0-600 sec.]

Function:

Defines for how long the Dry Pump condition must be active before activating Warning or Alarm

22-30 No-Flow Power

Range:

[Depends on the power size detection of No-Flow]

Function:

Read out of calculated No Flow power at actual speed. If power drops to the display value the frequency converter will consider the condition as a No Flow situation.

22-31 Power Correction Factor

Range:

100% [1-400%]

Function:

Make corrections to the calculated power at No Flow Detection (see par. 22-30).
If No Flow is detected the setting should be increased to above 100%. If however No Flow is not detected the setting should be decreased.

22-32 Low Speed [RPM]

Range:

0 RPM [0.0 - par. 4-13 (Motor High Speed Limit)]

Function:

To be used if par. 0-02, *Motor Speed Unit*, has been set for RPM (parameter not visible if Hz selected).
Set used speed for the 50% level.
This function is used for storing values needed to tune No Flow Detection.

22-33 Low Speed [Hz]

Range:

0 Hz* [0.0 - par. 4-14 (Motor High Speed Limit)]

Function:

To be used if par. 0-02, *Motor Speed Unit*, has been set for Hz (parameter not visible if RPM selected).
Set used speed for the 50% level.
The function is used for storing values needed to tune No Flow Detection.

22-34 Low Speed Power [kW]

Range:

0* [0.0 - par. 22-38]

Function:

To be used if par. 0-03, *Regional Settings*, has been set for International (parameter not visible if North America selected).
Set power consumption at 50% speed level.
This function is used for storing values needed to tune No Flow Detection.

22-35 Low Speed Power [Hp]

Range:

0* [0.0 - Par. 22-39]

Function:

To be used if par. 0-03, *Regional Settings*, has been set for North America (parameter not visible if International selected).
Set power consumption at 50% speed level.
This function is used for storing values needed to tune No Flow Detection.

22-36 High Speed [RPM]

Range:

0 RPM* [0.0 - par. 4-13 (Motor High Speed Limit)]

Function:

To be used if par. 0-02, *Motor Speed Unit*, has been set for RPM (parameter not visible if Hz selected).
Set used speed for the 85% level.
The function is used for storing values needed to tune No Flow Detection.

22-37 High Speed [Hz]

Range:

0 Hz* [0 - 1000 Hz]

Function:

To be used if *par. 0-02, Motor Speed Unit* has been set for Hz (parameter not visible if RPM selected).
Set used speed for the 85% level.
The function is used for storing values needed to tune No Flow Detection.

22-38 High Speed Power [kW]

Range:

0* [Size dependent]

Function:

To be used if *par. 0-03, Regional Settings*, has been set for International (parameter not visible if North America selected).
Set power consumption at 85% speed level.
This function is used for storing values needed to tune No Flow Detection.

22-39 High Speed Power [Hp]

Range:

0* [0.0 - Max Motor Output]

Function:

To be used if *par. 0-03, Regional Settings*, has been set for North America (parameter not visible if International selected).
Set power consumption at 85% speed level.
This function is used for storing values needed to tune No Flow Detection.

22-40 Minimum Run Time

Range:

10 s* [0 - 600 s]

Function:

Set the desired minimum running time for the motor after a Start command (digital input or Bus) before entering Sleep Mode.

22-41 Minimum Sleep Time

Range:

10 s* [0 - 600 s]

Function:

Set the desired minimum time for staying in Sleep Mode. This will override any wake up conditions.

22-42 Wake-Up Speed [RPM]

Range:

[par. 4-11 Motor Speed Low Limit -
par. 4-13 Motor Speed High Limit]

Function:

To be used if *par. 0-02 Motor Speed Unit* has been set for RPM (parameter not visible if Hz selected). Only to be used if *par. 1-00 Configuration Mode* is set for Open Loop and speed reference is applied by an external controller. Set the reference speed at which the Sleep Mode should be cancelled.

22-43 Wake-up Speed [Hz]

Range:

[Par. 4-12 (Motor Speed Low Limit)
- Par. 4-14 (Motor Speed High Limit)]

Function:

To be used if *par. 0-02, Motor Speed Unit*, has been set for Hz (parameter not visible if RPM selected). Only to be used if *par. 1-00, Configuration Mode*, is set for Open Loop and speed reference is applied by an external controller controlling the pressure.
Set the reference speed at which the Sleep Mode should be cancelled.

22-44 Wake-up Ref./FB Difference

Range:

10%* [0-100%]

Function:

Only to be used if *par. 1-00, Configuration Mode*, is set for Closed Loop and the integrated PI controller is used for controlling the pressure.
Set the pressure drop allowed in percentage of set point for the pressure (Pset) before cancelling the Sleep Mode.

**NB!**

If used in application where the integrated PI controller is set for inverse control in *par. 20-71, PID, Normal/Inverse Control*, the value set in *par. 22-44* will automatically be added.

22-45 Set Point Boost

Range:

0%* [-100% - +100%]

Function:

Only to be used if par. 1-00, *Configuration Mode*, is set for Closed Loop and the integrated PI controller is used. In systems with e.g. constant pressure control, it is advantageous to increase the system pressure before the motor is stopped. This will extend the time in which the motor is stopped and help to avoid frequent start/stop. Set the desired over pressure/temperature in percentage of set point for the pressure (Pset)/temperature before entering the Sleep Mode.

If setting for 5%, the boost pressure will be Pset*1.05. The negative values can be used for e.g. cooling tower control where a negative change is needed.

22-46 Maximum Boost Time

Range:

60 sec.* [0-600 sec.]

Function:

Only to be used if par. 1-00, *Configuration Mode*, is set for Closed Loop and the integrated PI controller is used for controlling the pressure.

Set the maximum time for which boost mode will be allowed. If the set time is exceeded, Sleep Mode will be entered, not waiting for the set boost pressure to be reached.

22-50 End of Curve Function

Option:

[0] * Off

Function:

End of Curve monitoring not active.

[1] Warning

A warning is issued in the display [W94].

[2] Alarm

An alarm is issued and the frequency converter trips. A message [A94] appears in the display.



NB!

Important: If using the cascade controller, the fixed speed pumps are not affected by the End of Curve function and will keep running.

22-51 End of Curve Delay

Range:

10 s* [0 to 600 s]

Function:

When an End of Curve condition is detected, a timer is activated. When the time set in this parameter expires, and the End of Curve condition has been steady in the entire period, the function set in par. 22-50, *End of Curve Function*, will be activated. If the condition disappears before the timer expires, the timer will be reset.

22-80 Flow Compensation

Option:

[0] * Disabled

Function:

[0] *Disabled*: Set-Point compensation not active.

[1] Enabled

[1] *Enabled*: Set-Point compensation is active. Enabling this parameter allows Flow Compensated Setpoint operation.

22-81 Square-Linear Curve Approximation

Range:

100%* [0 – 100%]

Function:

Example 1:

Adjustment of this parameter allows the shape of the control curve to be adjusted.

0 = Linear

100% = Ideal shape (theoretical).



NB!
Please note: Not visible when running in cascade.

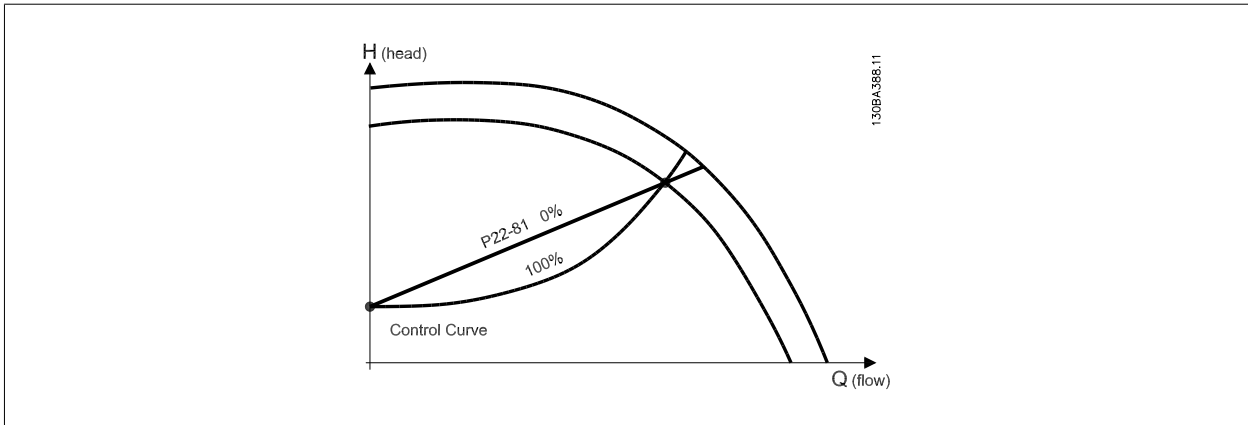

22-82 Work Point Calculation

Option:

[0] * Disabled

Function:

Disabled [0]: Work Point Calculation not active. To be used if speed at design point is known (see table above).

[1] Enabled

Enabled [1]: Work Point Calculation is active. Enabling this parameter allows the calculation of the unknown System Design Working Point at 50/60 Hz speed, from the input data set in par.22-83/84, 22-87, 22-88, 22-89 and 22-90.

Example 1: Speed at System Design Working Point is known:

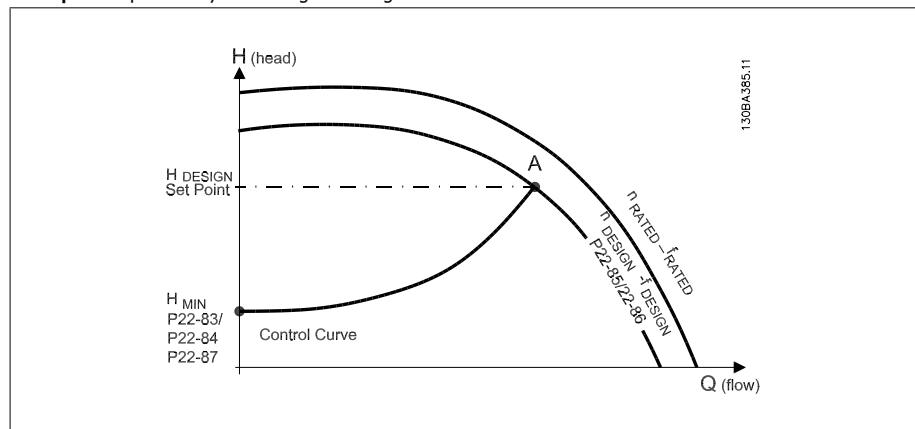

From the data sheet showing characteristics for the specific equipment at different speeds, simply reading across from the H_{DESIGN} point and the Q_{DESIGN} point allows us to find point A, which is the System Design Working Point. The pump characteristics at this point should be identified and the associated speed programmed. Closing the valves and adjusting the speed until H_{MIN} has been achieved allows the speed at the no flow point to be identified. Adjustment of par. 22-81 Square-Linear Curve Approximation then allows the shape of the control curve to be adjusted infinitely.

Example 2:

Speed at System Design Working Point is not known: Where the Speed at System Design Working Point is unknown, another reference point on the control curve needs to be determined by means of the data sheet. By looking at the curve for the rated speed and plotting the design pressure (H_{DESIGN} , Point C) the flow at that pressure Q_{RATED} can be determined. Similarly, by plotting the design flow (Q_{DESIGN} , Point D), the pressure H_D at that flow can be determined. Knowing these two points on the pump curve, along with H_{MIN} as described above, allows the frequency converter to calculate the reference point B and thus to plot the control curve which will also include the System design Working Point A.

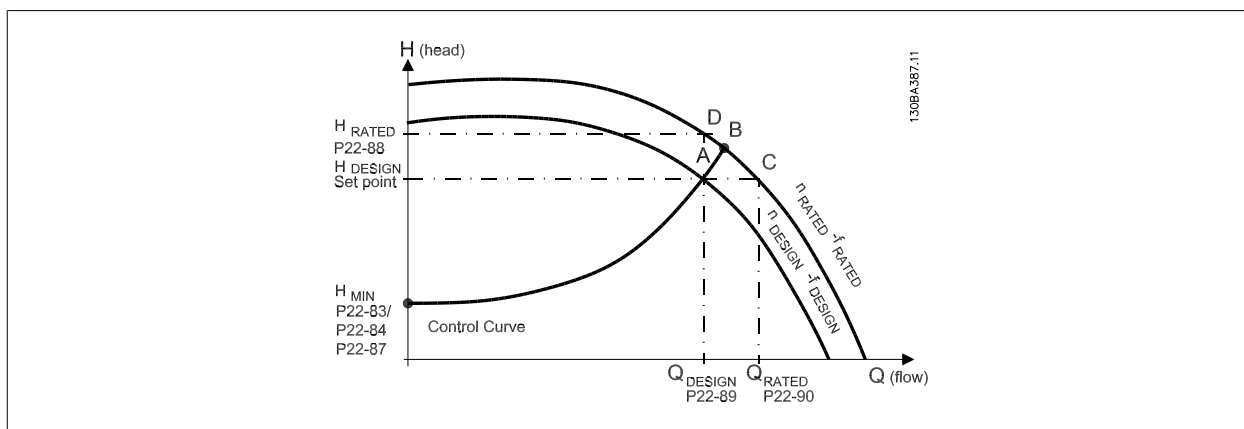

22-84 Speed at No-Flow [Hz]

Range:

10 Hz* [0 - Value of par. 22-86]

Function:

Resolution 0.033 Hz.

The speed of the motor at which flow has effectively stopped and minimum pressure H_{MIN} is achieved should be entered here in Hz. Alternatively, the speed in RPM can be entered in par. 22-83 Speed at No-Flow [RPM]. If it has been decided to use Hz in par. 0-02 then par. 22-86 Speed at Design point [Hz] should also be used. Closing the valves and reducing the speed until minimum pressure H_{MIN} is achieved will determine this value.

22-85 Speed at Design Point [RPM]

Range:

1500 RPM* [0 - 60,000]

Function:

Resolution 1 RPM.

Only visible when par. 22-82 Work Point Calculation, is set to *Disable*. The speed of the motor at which the System Design Working Point is achieved should be entered here in RPM. Alternatively, the speed in Hz can be entered in par. 22-86 Speed at Design Point [Hz]. If it has been decided to use RPM in par. 0-02 then par. 22-83 Speed No Flow [RPM] should also be used.

22-86 Speed at Design Point [Hz]

Range:

50 Hz* [0 - 1000 Hz]

Function:

Resolution 0.033 Hz.

Only visible when par. 22-82, Work Point Calculation, is set to *Disable*. The speed of the motor at which the System Design Working Point is achieved should be entered here in Hz. Alternatively, the speed in RPM can be entered in par. 22-85 Speed at Design Point [RPM]. If it has been decided to use Hz in par. 0-02, then par. 22-83 Speed No Flow [Hz] should also be used.

22-87 Pressure at No-Flow Speed

Range:

0 Reference/ Feedback Units* [0 - 999999.999]

Function:

Enter the pressure H_{MIN} corresponding to Speed at No Flow in Reference/Feedback Units.

22-88 Pressure at Rated Speed

Range:

0 Reference/ Feedback Units* [0 - 999999.999]

Function:

Enter the value corresponding to the Pressure at Rated Speed, in Reference/Feedback Units. This value can be defined using the pump datasheet.

22-83 Speed at No-Flow [RPM]

Range:

300 RPM* [0-Value of par. 22-85]

Function:

Resolution 1 RPM.

The speed of the motor at which flow is zero and minimum pressure H_{MIN} is achieved should be entered here in RPM. Alternatively, the speed in Hz can be entered in par 22-84 *Speed at No-Flow [Hz]*. If it has been decided to use RPM in par. 0-02 then par. 22-85 *Speed at Design point [RPM]* should also be used. Closing the valves and reducing the speed until minimum pressure H_{MIN} is achieved will determine this value.

22-90 Flow at Rated Speed

Range:

0* [0 - 999999.999]

Function:

Enter the value corresponding to Flow at Rated Speed. This value can be defined using the pump datasheet.

8.2.11. Timed Actions, 23-0*

Use *Timed Actions* for actions needing to be performed on a daily or weekly basis, e.g. different references for working hours / non-working hours. Up to 10 Timed Actions can be programmed in the frequency converter. The Timed Action number is selected from the list when entering parameter group 23-0* from the Local Control Panel. Par. 23-00 – 23-04 then refer to the selected Timed Action number. Each Timed Action is divided into an ON time and an OFF time, in which two different actions may be performed.

NB!

The clock (parameter group 0-7*) must be correctly programmed for Timed Actions to function correctly.

NB!

When mounting an Analog I/O MCB109 option card, a battery back up of the date and time is included.

23-00 ON Time

Array [10]

00:00:00* [00:00:00 –23:59:59]

Sets the ON time for the Timed Action.

NB!

The frequency converter has no back up of the clock function and the set date/time will reset to default (2000-01-01 00:00) after a power down unless a Real Time Clock module with back up is installed. In par. 0-79, *Clock Fault*, it is possible to program for a Warning in case clock has not been set properly, e.g. after a power down.

23-01 ON Action

Option:
Function:

Select the action during ON Time. See par. 13.52 *SL Controller Action* for descriptions of the options.

Array [10]

[0] * DISABLED

[1] No action

[2] Select setup 1

[3] Select setup 2

[4] Select setup 3

[5]	Select setup 4
[10]	Select preset ref. 0
[11]	Select preset ref. 1
[12]	Select preset ref. 2
[13]	Select preset ref. 3
[14]	Select preset ref. 4
[15]	Select preset ref. 5
[16]	Select preset ref. 6
[17]	Select preset ref. 7
[18]	Select ramp 1
[19]	Select ramp 2
[22]	Run
[23]	Run reverse
[24]	Stop
[26]	DC brake
[27]	Coast
[28]	Freeze output
[29]	Start timer 0
[30]	Start timer 1
[31]	Start timer 2
[32]	Set dig. out. A low
[33]	Set dig. out. B low
[34]	Set dig. out. C low
[35]	Set dig. out. D low
[36]	Set dig. out. E low
[37]	Set dig. out. F low
[38]	Set dig. out. A high
[39]	Set dig. out. B high
[40]	Set dig. out. C high
[41]	Set dig. out. D high
[42]	Set dig. out. E high
[43]	Set dig. out. F high
[60]	Reset counter A
[61]	Reset counter B
[70]	Start timer 3
[71]	Start timer 4
[72]	Start timer 5
[73]	Start timer 6
[74]	Start timer 7

23-02 OFF Time

Array [10]

00:00:00* [00:00:00 –23:59:59] Sets the OFF time for the Timed Action.

**NB!**

The frequency converter has no back up of the clock function and the set date/time will reset to default (2000-01-01 00:00) after a power down unless a Real Time Clock module with back up is installed. In par. 0-79, *Clock Fault*, it is possible to program for a Warning in case clock has not been set properly, e.g. after a power down.

23-03 OFF Action**Option:****Function:**

Select the action during OFF Time. See par. 13.52 *SL Controller Action* for descriptions of the options.

Array [10]

[0] *	DISABLED
[1]	No action
[2]	Select setup 1
[3]	Select setup 2
[4]	Select setup 3
[5]	Select setup 4
[10]	Select preset ref. 0
[11]	Select preset ref. 1
[12]	Select preset ref. 2
[13]	Select preset ref. 3
[14]	Select preset ref. 4
[15]	Select preset ref. 5
[16]	Select preset ref. 6
[17]	Select preset ref. 7
[18]	Select ramp 1
[19]	Select ramp 2
[22]	Run
[23]	Run reverse
[24]	Stop
[26]	DC brake
[27]	Coast
[28]	Freeze output
[29]	Start timer 0
[30]	Start timer 1
[31]	Start timer 2
[32]	Set dig. out. A low
[33]	Set dig. out. B low
[34]	Set dig. out. C low
[35]	Set dig. out. D low
[36]	Set dig. out. E low
[37]	Set dig. out. F low
[38]	Set dig. out. A high
[39]	Set dig. out. B high
[40]	Set dig. out. C high
[41]	Set dig. out. D high
[42]	Set dig. out. E high

[43] Set dig. out. F high

[60] Reset counter A

[61] Reset counter B

[70] Start timer 3

[71] Start timer 4

[72] Start timer 5

[73] Start timer 6

[74] Start timer 7

23-04 Occurrence

Option:

Function:

Select which day(s) the Timed Action applies to. Specify working/non-working days in par. 0-81, 0-82 and 0-83.

Array [10]

[0] * All days

[1] Working days

[2] Non-working days

[3] Monday

[4] Tuesday

[5] Wednesday

[6] Thursday

[7] Friday

[8] Saturday

[9] Sunday

8.2.12. Water Application Functions, 29- **

The group contains parameters used for monitoring water / wastewater applications.

29-00 Pipe Fill Enable**Option:**

[0] * Disabled

Function:

[1] Enabled Select Enabled to fill pipes with a user specified rate.

29-01 Pipe Fill Speed [RPM]**Range:**Speed Low Limit* [Speed Low Limit
- Speed High Limit]**Function:**

Set the filling speed for filling horizontal pipe systems. The speed can be selected in Hz or RPM depending on the choice in P4-11/P4-13 (RPM) or P4-12/P4-14 (Hz).

29-02 Pipe Fill Speed [Hz]**Range:**Motor Speed Low Limit* [Speed Low
Limit - Speed High Limit]**Function:**

Set the filling speed for filling horizontal pipe systems. The speed can be selected in Hz or RPM depending on the choice in P4-11/P4-13 (RPM) or P4-12/P4-14 (Hz).

29-03 Pipe Fill Time**Range:**

0 s* [0 - 3600 s]

Function:

Set the specified time for Pipe Fill of horizontal pipe systems.

29-04 Pipe Fill Rate**Range:**0.001 units/s* [0.001 –
999999.999]**Function:**

Specifies the filling rate units/second using the PI controller. Fill Rate units are Feedback Units/second. This function is for filling up vertical pipe systems.

29-05 Filled Setpoint**Range:**

0 s* [0 – 999999,999]

Function:

Specifies the Filled Setpoint at which the Pipe Fill Function will be disabled and PID controller will take control. This can be used both for horizontal and vertical pipe systems.

8.3. Parameter Options

All parameters in the VLT ® AQUA Drive FC 200 are listed in the following tables.

8.3.1. How to Read the Parameter Tabela

Changes during operation

“TRUE” means that the parameter can be changed while the frequency converter is in operation and “FALSE” means that the frequency converter must be stopped before a change can be made.

4-Set-up

'All set-up': the parameter can be set individually in each of the four set-ups, i. e. one single parameter can have four different data values.

'1 set-up': data value will be the same in all set-ups.

Conversion index

This number refers to a conversion figure used when writing or reading by means of a frequency converter.

Conv. index	100	67	6	5	4	3	2	1	0	-1	-2	-3	-4	-5	-6
Conv. factor	1	1/60	1000000	100000	10000	1000	100	10	1	0.1	0.01	0.001	0.0001	0.0000	0.000001

Data type	Description	Type
2	Integer 8	Int8
3	Integer 16	Int16
4	Integer 32	Int32
5	Unsigned 8	UInt8
6	Unsigned 16	UInt16
7	Unsigned 32	UInt32
9	Visible String	VisStr
33	Normalized value 2 bytes	N2
35	Bit sequence of 16 boolean variables	V2
54	Time difference w/o date	TimD

SR = Size related

8.3.2. Operation/Display 0- **

Par. No. #	Parameter description	Default value	4-set-up	Change during operation	Conversion index	Type
0-0* Basic Settings						
0-01	Language	[0] English	1 set-up	TRUE	-	Uint8
0-02	Motor Speed Unit	[0] RPM	2 set-ups	FALSE	-	Uint8
0-03	Regional Settings	[0] International	2 set-ups	FALSE	-	Uint8
0-04	Operating State at Power-up	[0] Resume	All set-ups	TRUE	-	Uint8
0-05	Local Mode Unit	[0] As Motor Speed Unit	2 set-ups	FALSE	-	Uint8
0-1* Set-up Operations						
0-10	Active Set-up	[1] Set-up 1	1 set-up	TRUE	-	Uint8
0-11	Programming Set-up	[9] Active Set-up	All set-ups	TRUE	-	Uint8
0-12	This Set-up Linked to	[0] Not linked	All set-ups	FALSE	-	Uint8
0-13	Readout: Linked Set-ups	0 N/A	All set-ups	FALSE	0	Uint16
0-14	Readout: Prog. Set-ups / Channel	0 N/A	All set-ups	TRUE	0	Int32
0-2* LCP Display						
0-20	Display Line 1.1 Small	1601	All set-ups	TRUE	-	Uint16
0-21	Display Line 1.2 Small	1662	All set-ups	TRUE	-	Uint16
0-22	Display Line 1.3 Small	1614	All set-ups	TRUE	-	Uint16
0-23	Display Line 2 Large	1613	All set-ups	TRUE	-	Uint16
0-24	Display Line 3 Large	1652	All set-ups	TRUE	-	Uint16
0-25	My Personal Menu	SR	1 set-up	TRUE	0	Uint16
0-3* LCP Custom Readout						
0-30	Custom Readout Unit	[1] %	All set-ups	TRUE	-	Uint8
0-31	Custom Readout Min Value	SR	All set-ups	TRUE	-2	Int32
0-32	Custom Readout Max Value	100.00 CustomReadoutUnit	All set-ups	TRUE	-2	Int32
0-37	Display Text 1	0 N/A	1 set-up	TRUE	0	VisStr[25]
0-38	Display Text 2	0 N/A	1 set-up	TRUE	0	VisStr[25]
0-39	Display Text 3	0 N/A	1 set-up	TRUE	0	VisStr[25]
0-4* LCP Keypad						
0-40	[Hand on] Key on LCP	[1] Enabled	All set-ups	TRUE	-	Uint8
0-41	[Off] Key on LCP	[1] Enabled	All set-ups	TRUE	-	Uint8
0-42	[Auto on] Key on LCP	[1] Enabled	All set-ups	TRUE	-	Uint8
0-43	[Reset] Key on LCP	[1] Enabled	All set-ups	TRUE	-	Uint8
0-44	[Off/Reset] Key on LCP	[1] Enabled	All set-ups	TRUE	-	Uint8
0-45	[Drive Bypass] Key on LCP	[1] Enabled	All set-ups	TRUE	-	Uint8
0-5* Copy/Save						
0-50	LCP Copy	[0] No copy	All set-ups	FALSE	-	Uint8
0-51	Set-up Copy	[0] No copy	All set-ups	FALSE	-	Uint8
0-6* Password						
0-60	Main Menu Password	100 N/A	1 set-up	TRUE	0	Uint16
0-61	Access to Main Menu w/o Password	[0] Full access	1 set-up	TRUE	-	Uint8
0-65	Personal Menu Password	200 N/A	1 set-up	TRUE	0	Uint16
0-66	Access to Personal Menu w/o Password	[0] Full access	1 set-up	TRUE	-	Uint8

Par. No. #	Parameter description	Default value	4-set-up	Change during operation	Conversion index	Type
0-7* Clock Settings						
0-70	Set Date and Time	SR	1 set-up	TRUE	0	TimeOfDay
0-71	Date Format	[0] YYYY-MM-DD	1 set-up	TRUE	-	UInt8
0-72	Time Format	[0] 24 h	1 set-up	TRUE	-	UInt8
0-74	DST/Summertime	[0] Off	1 set-up	TRUE	-	UInt8
0-76	DST/Summertime Start	SR	1 set-up	TRUE	0	TimeOfDay
0-77	DST/Summertime End	SR	1 set-up	TRUE	0	TimeOfDay
0-79	Clock Fault	[0] Disabled	1 set-up	TRUE	-	UInt8
0-81	Working Days	null	1 set-up	TRUE	-	UInt8
0-82	Additional Working Days	SR	1 set-up	TRUE	0	TimeOfDay
0-83	Additional Non-Working Days	SR	1 set-up	TRUE	0	TimeOfDay
0-89	Date and Time Readout	0 N/A	All set-ups	TRUE	0	VisStr[25]

8.3.3. Load/Motor 1-**-*

Par. No. #	Parameter description	Default value	4-set-up	Change during operation	Conversion index	Type
1-0* General Settings						
1-00	Configuration Mode	null	All set-ups	TRUE	-	Uint8
1-01	Motor Control Principle	null	All set-ups	FALSE	-	Uint8
1-03	Torque Characteristics	null	All set-ups	TRUE	-	Uint8
1-2* Motor Data						
1-20	Motor Power [kW]	SR	All set-ups	FALSE	1	Uint32
1-21	Motor Power [HP]	SR	All set-ups	FALSE	-2	Uint32
1-22	Motor Voltage	SR	All set-ups	FALSE	0	Uint16
1-23	Motor Frequency	SR	All set-ups	FALSE	0	Uint16
1-24	Motor Current	SR	All set-ups	FALSE	-2	Uint32
1-25	Motor Nominal Speed	SR	All set-ups	FALSE	67	Uint16
1-28	Motor Rotation Check	[0] Off	All set-ups	FALSE	-	Uint8
1-29	Automatic Motor Adaptation (AMA)	[0] Off	All set-ups	FALSE	-	Uint8
1-3* Adv. Motor Data						
1-30	Stator Resistance (Rs)	SR	All set-ups	FALSE	-4	Uint32
1-31	Rotor Resistance (Rr)	SR	All set-ups	FALSE	-4	Uint32
1-35	Main Reactance (Xh)	SR	All set-ups	FALSE	-4	Uint32
1-36	Iron Loss Resistance (Rfe)	SR	All set-ups	FALSE	-3	Uint32
1-39	Motor Poles	SR	All set-ups	FALSE	0	Uint8
1-5* Load Indep. Setting						
1-50	Motor Magnetisation at Zero Speed	100 %	All set-ups	TRUE	0	Uint16
1-51	Min Speed Normal Magnetising [RPM]	SR	All set-ups	TRUE	67	Uint16
1-52	Min Speed Normal Magnetising [Hz]	SR	All set-ups	TRUE	-1	Uint16
1-6* Load Depen. Setting						
1-60	Low Speed Load Compensation	100 %	All set-ups	TRUE	0	Int16
1-61	High Speed Load Compensation	100 %	All set-ups	TRUE	0	Int16
1-62	Slip Compensation	0 %	All set-ups	TRUE	0	Int16
1-63	Slip Compensation Time Constant	SR	All set-ups	TRUE	-2	Uint16
1-64	Resonance Dampening	100 %	All set-ups	TRUE	0	Uint16
1-65	Resonance Dampening Time Constant	5 ms	All set-ups	TRUE	-3	Uint8
1-7* Start Adjustments						
1-71	Start Delay	0.0 s	All set-ups	TRUE	-1	Uint16
1-73	Flying Start	[0] Disabled	All set-ups	FALSE	-	Uint8
1-8* Stop Adjustments						
1-80	Function at Stop	[0] Coast	All set-ups	TRUE	-	Uint8
1-81	Min Speed for Function at Stop [RPM]	SR	All set-ups	TRUE	67	Uint16
1-82	Min Speed for Function at Stop [Hz]	SR	All set-ups	TRUE	-1	Uint16
1-9* Motor Temperature						
1-90	Motor Thermal Protection	[4] ETR trip 1	All set-ups	TRUE	-	Uint8
1-91	Motor External Fan	[0] No	All set-ups	TRUE	-	Uint16
1-93	Thermistor Source	[0] None	All set-ups	TRUE	-	Uint8

8.3.4. Brakes 2-.* *

Par. No. #	Parameter description	Default value	4-set-up	Change during operation	Conversion index	Type
2-0* DC-Brake						
2-00	DC Hold/Preheat Current	50 %	All set-ups	TRUE	0	Uint8
2-01	DC Brake Current	50 %	All set-ups	TRUE	0	Uint16
2-02	DC Braking Time	10.0 s	All set-ups	TRUE	-1	Uint16
2-03	DC Brake Cut In Speed [RPM]	SR	All set-ups	TRUE	67	Uint16
2-04	DC Brake Cut In Speed [Hz]	SR	All set-ups	TRUE	-1	Uint16
2-1* Brake Energy Funct.						
2-10	Brake Function	[0] Off	All set-ups	TRUE	-	Uint8
2-11	Brake Resistor (ohm)	SR	All set-ups	TRUE	0	Uint16
2-12	Brake Power Limit (kW)	SR	All set-ups	TRUE	0	Uint32
2-13	Brake Power Monitoring	[0] Off	All set-ups	TRUE	-	Uint8
2-15	Brake Check	[0] Off	All set-ups	TRUE	-	Uint8
2-16	AC brake Max. Current	100.0 %	All set-ups	TRUE	-1	Uint32
2-17	Over-voltage Control	[2] Enabled	All set-ups	TRUE	-	Uint8

8.3.5. Reference / Ramps 3- **

Par. No. #	Parameter description	Default value	4-set-up	Change during operation	Conversion index	Type
3-0* Reference Limits						
3-02	Minimum Reference	SR	All set-ups	TRUE	-3	Int32
3-03	Maximum Reference	SR	All set-ups	TRUE	-3	Int32
3-04	Reference Function	[0] Sum	All set-ups	TRUE	-	UInt8
3-1* References						
3-10	Preset Reference	0.00 %	All set-ups	TRUE	-2	Int16
3-11	Jog Speed [Hz]	SR	All set-ups	TRUE	-1	UInt16
3-13	Reference Site	[0] Linked to Hand / Auto	All set-ups	TRUE	-	UInt8
3-14	Preset Relative Reference	0.00 %	All set-ups	TRUE	-2	Int32
3-15	Reference 1 Source	[1] Analog input 53	All set-ups	TRUE	-	UInt8
3-16	Reference 2 Source	[0] No function	All set-ups	TRUE	-	UInt8
3-17	Reference 3 Source	[0] No function	All set-ups	TRUE	-	UInt8
3-19	Jog Speed [RPM]	SR	All set-ups	TRUE	67	UInt16
3-4* Ramp 1						
3-41	Ramp 1 Ramp Up Time	SR	All set-ups	TRUE	-2	UInt32
3-42	Ramp 1 Ramp Down Time	SR	All set-ups	TRUE	-2	UInt32
3-5* Ramp 2						
3-51	Ramp 2 Ramp Up Time	SR	All set-ups	TRUE	-2	UInt32
3-52	Ramp 2 Ramp Down Time	SR	All set-ups	TRUE	-2	UInt32
3-8* Other Ramps						
3-80	Jog Ramp Time	SR	All set-ups	TRUE	-2	UInt32
3-81	Quick Stop Ramp Time	SR	2 set-ups	TRUE	-2	UInt32
3-84	Initial Ramp Time	0.00 s	All set-ups	TRUE	-2	UInt16
3-85	Check Valve Ramp Time	0.00 s	All set-ups	TRUE	-2	UInt16
3-86	Check Valve Ramp End Speed [RPM]	SR	All set-ups	TRUE	67	UInt16
3-87	Check Valve Ramp End Speed [Hz]	SR	All set-ups	TRUE	-1	UInt16
3-88	Final Ramp Time	0.00 s	All set-ups	TRUE	-2	UInt16
3-9* Digital Pot.Meter						
3-90	Step Size	0.10 %	All set-ups	TRUE	-2	UInt16
3-91	Ramp Time	1.00 s	All set-ups	TRUE	-2	UInt32
3-92	Power Restore	[0] Off	All set-ups	TRUE	-	UInt8
3-93	Maximum Limit	100 %	All set-ups	TRUE	0	Int16
3-94	Minimum Limit	0 %	All set-ups	TRUE	0	Int16
3-95	Ramp Delay	1.000 N/A	All set-ups	TRUE	-3	TimD

8.3.6. Limits / Warnings 4-**

Par. No. #	Parameter description	Default value	4-set-up	Change during operation	Conversion index	Type
4-1* Motor Limits						
4-10	Motor Speed Direction	[0] Clockwise	All set-ups	FALSE	-	UInt8
4-11	Motor Speed Low Limit [RPM]	SR	All set-ups	TRUE	67	UInt16
4-12	Motor Speed Low Limit [Hz]	SR	All set-ups	TRUE	-1	UInt16
4-13	Motor Speed High Limit [RPM]	SR	All set-ups	TRUE	67	UInt16
4-14	Motor Speed High Limit [Hz]	SR	All set-ups	TRUE	-1	UInt16
4-16	Torque Limit Motor Mode	110.0 %	All set-ups	TRUE	-1	UInt16
4-17	Torque Limit Generator Mode	100.0 %	All set-ups	TRUE	-1	UInt16
4-18	Current Limit	SR	All set-ups	TRUE	-1	UInt32
4-19	Max Output Frequency	SR	All set-ups	FALSE	-1	UInt16
4-5* Adj. Warnings						
4-50	Warning Current Low	0.00 A	All set-ups	TRUE	-2	UInt32
4-51	Warning Current High	ImaxVLT (P1637)	All set-ups	TRUE	-2	UInt32
4-52	Warning Speed Low	0 RPM	All set-ups	TRUE	67	UInt16
4-53	Warning Speed High	outputSpeedHighLimit (P413)	All set-ups	TRUE	67	UInt16
4-54	Warning Reference Low	-999999.999 N/A	All set-ups	TRUE	-3	Int32
4-55	Warning Reference High	999999.999 N/A	All set-ups	TRUE	-3	Int32
4-56	Warning Feedback Low	-999999.999 ReferenceFeedbackUnit	All set-ups	TRUE	-3	Int32
4-57	Warning Feedback High	999999.999 ReferenceFeedbackUnit	All set-ups	TRUE	-3	Int32
4-58	Missing Motor Phase Function	[1] On	All set-ups	TRUE	-	UInt8
4-6* Speed Bypass						
4-60	Bypass Speed From [RPM]	SR	All set-ups	TRUE	67	UInt16
4-61	Bypass Speed From [Hz]	SR	All set-ups	TRUE	-1	UInt16
4-62	Bypass Speed To [RPM]	SR	All set-ups	TRUE	67	UInt16
4-63	Bypass Speed To [Hz]	SR	All set-ups	TRUE	-1	UInt16
4-64	Semi-Auto Bypass Set-up	[0] Off	All set-ups	FALSE	-	UInt8

8.3.7. Digital In/Out 5- **

Par. No. #	Parameter description	Default value	4-set-up	Change during operation	Conversion index	Type
5-0* Digital I/O mode						
5-00	Digital I/O Mode	[0] PNP - Active at 24V	All set-ups	FALSE	-	Uint8
5-01	Terminal 27 Mode	[0] Input	All set-ups	TRUE	-	Uint8
5-02	Terminal 29 Mode	[0] Input	All set-ups	TRUE	-	Uint8
5-1* Digital Inputs						
5-10	Terminal 18 Digital Input	[8] Start	All set-ups	TRUE	-	Uint8
5-11	Terminal 19 Digital Input	[0] No operation	All set-ups	TRUE	-	Uint8
5-12	Terminal 27 Digital Input	null	All set-ups	TRUE	-	Uint8
5-13	Terminal 29 Digital Input	[0] No operation	All set-ups	TRUE	-	Uint8
5-14	Terminal 32 Digital Input	[0] No operation	All set-ups	TRUE	-	Uint8
5-15	Terminal 33 Digital Input	[0] No operation	All set-ups	TRUE	-	Uint8
5-16	Terminal X30/2 Digital Input	[0] No operation	All set-ups	TRUE	-	Uint8
5-17	Terminal X30/3 Digital Input	[0] No operation	All set-ups	TRUE	-	Uint8
5-18	Terminal X30/4 Digital Input	[0] No operation	All set-ups	TRUE	-	Uint8
5-3* Digital Outputs						
5-30	Terminal 27 Digital Output	[0] No operation	All set-ups	TRUE	-	Uint8
5-31	Terminal 29 Digital Output	[0] No operation	All set-ups	TRUE	-	Uint8
5-32	Term X30/6 Digi Out (MCB 101)	[0] No operation	All set-ups	TRUE	-	Uint8
5-33	Term X30/7 Digi Out (MCB 101)	[0] No operation	All set-ups	TRUE	-	Uint8
5-4* Relays						
5-40	Function Relay	null	All set-ups	TRUE	-	Uint8
5-41	On Delay, Relay	0.01 s	All set-ups	TRUE	-2	Uint16
5-42	Off Delay, Relay	0.01 s	All set-ups	TRUE	-2	Uint16
5-5* Pulse Input						
5-50	Term. 29 Low Frequency	100 Hz	All set-ups	TRUE	0	Uint32
5-51	Term. 29 High Frequency	100 Hz	All set-ups	TRUE	0	Uint32
5-52	Term. 29 Low Ref./Feedb. Value	0.000 N/A	All set-ups	TRUE	-3	Int32
5-53	Term. 29 High Ref./Feedb. Value	100.000 N/A	All set-ups	TRUE	-3	Int32
5-54	Pulse Filter Time Constant #29	100 ms	All set-ups	FALSE	-3	Uint16
5-55	Term. 33 Low Frequency	100 Hz	All set-ups	TRUE	0	Uint32
5-56	Term. 33 High Frequency	100 Hz	All set-ups	TRUE	0	Uint32
5-57	Term. 33 Low Ref./Feedb. Value	0.000 N/A	All set-ups	TRUE	-3	Int32
5-58	Term. 33 High Ref./Feedb. Value	100.000 N/A	All set-ups	TRUE	-3	Int32
5-59	Pulse Filter Time Constant #33	100 ms	All set-ups	FALSE	-3	Uint16
5-6* Pulse Output						
5-60	Terminal 27 Pulse Output Variable	[0] No operation	All set-ups	TRUE	-	Uint8
5-62	Pulse Output Max Freq #27	5000 Hz	All set-ups	TRUE	0	Uint32
5-63	Terminal 29 Pulse Output Variable	[0] No operation	All set-ups	TRUE	-	Uint8
5-65	Pulse Output Max Freq #29	5000 Hz	All set-ups	TRUE	0	Uint32
5-66	Terminal X30/6 Pulse Output Variable	[0] No operation	All set-ups	TRUE	-	Uint8
5-68	Pulse Output Max Freq #X30/6	5000 Hz	All set-ups	TRUE	0	Uint32
5-9* Bus Controlled						
5-90	Digital & Relay Bus Control	0 N/A	All set-ups	TRUE	0	Uint32
5-93	Pulse Out #27 Bus Control	0.00 %	All set-ups	TRUE	-2	N2
5-94	Pulse Out #27 Timeout Preset	0.00 %	1 set-up	TRUE	-2	Uint16
5-95	Pulse Out #29 Bus Control	0.00 %	All set-ups	TRUE	-2	N2
5-96	Pulse Out #29 Timeout Preset	0.00 %	1 set-up	TRUE	-2	Uint16
5-97	Pulse Out #X30/6 Bus Control	0.00 %	All set-ups	TRUE	-2	N2
5-98	Pulse Out #X30/6 Timeout Preset	0.00 %	1 set-up	TRUE	-2	Uint16

8.3.8. Analog In/Out 6-*

Par. No. #	Parameter description	Default value	4-set-up	Change during operation	Conversion index	Type
6-0* Analog I/O Mode						
6-00	Live Zero Timeout Time	10 s	All set-ups	TRUE	0	Uint8
6-01	Live Zero Timeout Function	[0] Off	All set-ups	TRUE	-	Uint8
6-02	Fire Mode Live Zero Timeout Function	null	All set-ups	TRUE	-	Uint8
6-1* Analog Input 53						
6-10	Terminal 53 Low Voltage	0.07 V	All set-ups	TRUE	-2	Int16
6-11	Terminal 53 High Voltage	10.00 V	All set-ups	TRUE	-2	Int16
6-12	Terminal 53 Low Current	4.00 mA	All set-ups	TRUE	-5	Int16
6-13	Terminal 53 High Current	20.00 mA	All set-ups	TRUE	-5	Int16
6-14	Terminal 53 Low Ref./Feedb. Value	0.000 N/A	All set-ups	TRUE	-3	Int32
6-15	Terminal 53 High Ref./Feedb. Value	SR	All set-ups	TRUE	-3	Int32
6-16	Terminal 53 Filter Time Constant	0.001 s	All set-ups	TRUE	-3	Uint16
6-17	Terminal 53 Live Zero	[1] Enabled	All set-ups	TRUE	-	Uint8
6-2* Analog Input 54						
6-20	Terminal 54 Low Voltage	0.07 V	All set-ups	TRUE	-2	Int16
6-21	Terminal 54 High Voltage	10.00 V	All set-ups	TRUE	-2	Int16
6-22	Terminal 54 Low Current	4.00 mA	All set-ups	TRUE	-5	Int16
6-23	Terminal 54 High Current	20.00 mA	All set-ups	TRUE	-5	Int16
6-24	Terminal 54 Low Ref./Feedb. Value	0.000 N/A	All set-ups	TRUE	-3	Int32
6-25	Terminal 54 High Ref./Feedb. Value	100.000 N/A	All set-ups	TRUE	-3	Int32
6-26	Terminal 54 Filter Time Constant	0.001 s	All set-ups	TRUE	-3	Uint16
6-27	Terminal 54 Live Zero	[1] Enabled	All set-ups	TRUE	-	Uint8
6-3* Analog Input X30/11						
6-30	Terminal X30/11 Low Voltage	0.07 V	All set-ups	TRUE	-2	Int16
6-31	Terminal X30/11 High Voltage	10.00 V	All set-ups	TRUE	-2	Int16
6-34	Term. X30/11 Low Ref./Feedb. Value	0.000 N/A	All set-ups	TRUE	-3	Int32
6-35	Term. X30/11 High Ref./Feedb. Value	100.000 N/A	All set-ups	TRUE	-3	Int32
6-36	Term. X30/11 Filter Time Constant	0.001 s	All set-ups	TRUE	-3	Uint16
6-37	Term. X30/11 Live Zero	[1] Enabled	All set-ups	TRUE	-	Uint8
6-4* Analog Input X30/12						
6-40	Terminal X30/12 Low Voltage	0.07 V	All set-ups	TRUE	-2	Int16
6-41	Terminal X30/12 High Voltage	10.00 V	All set-ups	TRUE	-2	Int16
6-44	Term. X30/12 Low Ref./Feedb. Value	0.000 N/A	All set-ups	TRUE	-3	Int32
6-45	Term. X30/12 High Ref./Feedb. Value	100.000 N/A	All set-ups	TRUE	-3	Int32
6-46	Term. X30/12 Filter Time Constant	0.001 s	All set-ups	TRUE	-3	Uint16
6-47	Term. X30/12 Live Zero	[1] Enabled	All set-ups	TRUE	-	Uint8
6-5* Analog Output 42						
6-50	Terminal 42 Output	[100] Output frequency	All set-ups	TRUE	-	Uint8
6-51	Terminal 42 Output Min Scale	0.00 %	All set-ups	TRUE	-2	Int16
6-52	Terminal 42 Output Max Scale	100.00 %	All set-ups	TRUE	-2	Int16
6-53	Terminal 42 Output Bus Control	0.00 %	All set-ups	TRUE	-2	N2
6-54	Terminal 42 Output Timeout Preset	0.00 %	1 set-up	TRUE	-2	Uint16
6-6* Analog Output X30/8						
6-60	Terminal X30/8 Output	[0] No operation	All set-ups	TRUE	-	Uint8
6-61	Terminal X30/8 Min. Scale	0.00 %	All set-ups	TRUE	-2	Int16
6-62	Terminal X30/8 Max. Scale	100.00 %	All set-ups	TRUE	-2	Int16
6-63	Terminal X30/8 Output Bus Control	0.00 %	All set-ups	TRUE	-2	N2
6-64	Terminal X30/8 Output Timeout Preset	0.00 %	1 set-up	TRUE	-2	Uint16

8.3.9. Comm. and Options 8-.*

Par. No. #	Parameter description	Default value	4-set-up	Change during operation	Conversion index	Type
8-0* General Settings						
8-01	Control Site	[0] Digital and ctrl.word	All set-ups	TRUE	-	Uint8
8-02	Control Source	null	All set-ups	TRUE	-	Uint8
8-03	Control Timeout Time	SR	1 set-up	TRUE	-1	Uint32
8-04	Control Timeout Function	[0] Off	1 set-up	TRUE	-	Uint8
8-05	End-of-Timeout Function	[1] Resume set-up	1 set-up	TRUE	-	Uint8
8-06	Reset Control Timeout	[0] Do not reset	All set-ups	TRUE	-	Uint8
8-07	Diagnosis Trigger	[0] Disable	2 set-ups	TRUE	-	Uint8
8-1* Control Settings						
8-10	Control Profile	[0] FC profile	All set-ups	TRUE	-	Uint8
8-13	Configurable Status Word STW	[1] Profile Default	All set-ups	TRUE	-	Uint8
8-3* FC Port Settings						
8-30	Protocol	[0] FC	1 set-up	TRUE	-	Uint8
8-31	Address	1 N/A	1 set-up	TRUE	0	Uint8
8-32	Baud Rate	null	1 set-up	TRUE	-	Uint8
8-33	Parity / Stop Bits	null	1 set-up	TRUE	-	Uint8
8-35	Minimum Response Delay	10 ms	1 set-up	TRUE	-3	Uint16
8-36	Max Response Delay	SR	1 set-up	TRUE	-3	Uint16
8-37	Max Inter-Char Delay	SR	1 set-up	TRUE	-5	Uint16
8-4* FC MC protocol set						
8-40	Telegram Selection	[1] Standard telegram 1	2 set-ups	TRUE	-	Uint8
8-5* Digital/Bus						
8-50	Coasting Select	[3] Logic OR	All set-ups	TRUE	-	Uint8
8-52	DC Brake Select	[3] Logic OR	All set-ups	TRUE	-	Uint8
8-53	Start Select	[3] Logic OR	All set-ups	TRUE	-	Uint8
8-54	Reversing Select	[0] Digital input	All set-ups	TRUE	-	Uint8
8-55	Set-up Select	[3] Logic OR	All set-ups	TRUE	-	Uint8
8-56	Preset Reference Select	[3] Logic OR	All set-ups	TRUE	-	Uint8
8-7* BACnet						
8-70	BACnet Device Instance	1 N/A	1 set-up	TRUE	0	Uint32
8-72	MS/TP Max Masters	127 N/A	1 set-up	TRUE	0	Uint8
8-73	MS/TP Max Info Frames	1 N/A	1 set-up	TRUE	0	Uint16
8-74	"I-Am" Service	[0] Send at power-up	1 set-up	TRUE	-	Uint8
8-75	Initialisation Password	0 N/A	1 set-up	TRUE	0	VisStr[20]
8-8* FC Port Diagnostics						
8-80	Bus Message Count	0 N/A	All set-ups	TRUE	0	Uint32
8-81	Bus Error Count	0 N/A	All set-ups	TRUE	0	Uint32
8-82	Slave Message Count	0 N/A	All set-ups	TRUE	0	Uint32
8-83	Slave Error Count	0 N/A	All set-ups	TRUE	0	Uint32
8-9* Bus Jog / Feedback						
8-90	Bus Jog 1 Speed	100 RPM	All set-ups	TRUE	67	Uint16
8-91	Bus Jog 2 Speed	200 RPM	All set-ups	TRUE	67	Uint16
8-94	Bus Feedback 1	0 N/A	1 set-up	TRUE	0	N2
8-95	Bus Feedback 2	0 N/A	1 set-up	TRUE	0	N2
8-96	Bus Feedback 3	0 N/A	1 set-up	TRUE	0	N2

8.3.10. Profibus 9_**

Par. No. #	Parameter description	Default value	4-set-up	Change during operation	Conversion index	Type
9-00	Setpoint	0 N/A	All set-ups	TRUE	0	Uint16
9-07	Actual Value	0 N/A	All set-ups	FALSE	0	Uint16
9-15	PCD Write Configuration	SR	2 set-ups	TRUE	-	Uint16
9-16	PCD Read Configuration	SR	2 set-ups	TRUE	-	Uint16
9-18	Node Address	126 N/A	1 set-up	TRUE	0	Uint8
9-22	Telegram Selection	[108] PPO 8	1 set-up	TRUE	-	Uint8
9-23	Parameters for Signals	0	All set-ups	TRUE	-	Uint16
9-27	Parameter Edit	[1] Enabled	2 set-ups	FALSE	-	Uint16
9-28	Process Control	[1] Enable cyclic master	2 set-ups	FALSE	-	Uint8
9-44	Fault Message Counter	0 N/A	All set-ups	TRUE	0	Uint16
9-45	Fault Code	0 N/A	All set-ups	TRUE	0	Uint16
9-47	Fault Number	0 N/A	All set-ups	TRUE	0	Uint16
9-52	Fault Situation Counter	0 N/A	All set-ups	TRUE	0	Uint16
9-53	Profibus Warning Word	0 N/A	All set-ups	TRUE	0	V2
9-63	Actual Baud Rate	[255] No baudrate found	All set-ups	TRUE	-	Uint8
9-64	Device Identification	0 N/A	All set-ups	TRUE	0	Uint16
9-65	Profile Number	0 N/A	All set-ups	TRUE	0	OctStr[2]
9-67	Control Word 1	0 N/A	All set-ups	TRUE	0	V2
9-68	Status Word 1	0 N/A	All set-ups	TRUE	0	V2
9-71	Profibus Save Data Values	[0] Off	All set-ups	TRUE	-	Uint8
9-72	ProfibusDriveReset	[0] No action	1 set-up	FALSE	-	Uint8
9-80	Defined Parameters (1)	0 N/A	All set-ups	FALSE	0	Uint16
9-81	Defined Parameters (2)	0 N/A	All set-ups	FALSE	0	Uint16
9-82	Defined Parameters (3)	0 N/A	All set-ups	FALSE	0	Uint16
9-83	Defined Parameters (4)	0 N/A	All set-ups	FALSE	0	Uint16
9-84	Defined Parameters (5)	0 N/A	All set-ups	FALSE	0	Uint16
9-90	Changed Parameters (1)	0 N/A	All set-ups	FALSE	0	Uint16
9-91	Changed Parameters (2)	0 N/A	All set-ups	FALSE	0	Uint16
9-92	Changed Parameters (3)	0 N/A	All set-ups	FALSE	0	Uint16
9-93	Changed Parameters (4)	0 N/A	All set-ups	FALSE	0	Uint16
9-94	Changed Parameters (5)	0 N/A	All set-ups	FALSE	0	Uint16

8.3.11. CAN Fieldbus 10-.*

Par. No. #	Parameter description	Default value	4-set-up	Change during operation	Conversion index	Type
10-0* Common Settings						
10-00	CAN Protocol	null	2 set-ups	FALSE	-	Uint8
10-01	Baud Rate Select	null	2 set-ups	TRUE	-	Uint8
10-02	MAC ID	SR	2 set-ups	TRUE	0	Uint8
10-05	Readout Transmit Error Counter	0 N/A	All set-ups	TRUE	0	Uint8
10-06	Readout Receive Error Counter	0 N/A	All set-ups	TRUE	0	Uint8
10-07	Readout Bus Off Counter	0 N/A	All set-ups	TRUE	0	Uint8
10-1* DeviceNet						
10-10	Process Data Type Selection	null	All set-ups	TRUE	-	Uint8
10-11	Process Data Config Write	SR	2 set-ups	TRUE	-	Uint16
10-12	Process Data Config Read	SR	2 set-ups	TRUE	-	Uint16
10-13	Warning Parameter	0 N/A	All set-ups	TRUE	0	Uint16
10-14	Net Reference	[0] Off	2 set-ups	TRUE	-	Uint8
10-15	Net Control	[0] Off	2 set-ups	TRUE	-	Uint8
10-2* COS Filters						
10-20	COS Filter 1	0 N/A	All set-ups	FALSE	0	Uint16
10-21	COS Filter 2	0 N/A	All set-ups	FALSE	0	Uint16
10-22	COS Filter 3	0 N/A	All set-ups	FALSE	0	Uint16
10-23	COS Filter 4	0 N/A	All set-ups	FALSE	0	Uint16
10-3* Parameter Access						
10-30	Array Index	0 N/A	2 set-ups	TRUE	0	Uint8
10-31	Store Data Values	[0] Off	All set-ups	TRUE	-	Uint8
10-32	DeviceNet Revision	SR	All set-ups	TRUE	0	Uint16
10-33	Store Always	[0] Off	1 set-up	TRUE	-	Uint8
10-34	DeviceNet Product Code	120 N/A	1 set-up	TRUE	0	Uint16
10-39	DeviceNet F Parameters	0 N/A	All set-ups	TRUE	0	Uint32

8.3.12. Smart Logic 13-**

Par. No. #	Parameter description	Default value	4-set-up	Change during operation	Conversion index	Type
13-0* SLC Settings						
13-00	SL Controller Mode	null	2 set-ups	TRUE	-	Uint8
13-01	Start Event	null	2 set-ups	TRUE	-	Uint8
13-02	Stop Event	null	2 set-ups	TRUE	-	Uint8
13-03	Reset SLC	[0] Do not reset SLC	All set-ups	TRUE	-	Uint8
13-1* Comparators						
13-10	Comparator Operand	null	2 set-ups	TRUE	-	Uint8
13-11	Comparator Operator	null	2 set-ups	TRUE	-	Uint8
13-12	Comparator Value	SR	2 set-ups	TRUE	-3	Int32
13-2* Timers						
13-20	SL Controller Timer	SR	1 set-up	TRUE	-3	TimD
13-4* Logic Rules						
13-40	Logic Rule Boolean 1	null	2 set-ups	TRUE	-	Uint8
13-41	Logic Rule Operator 1	null	2 set-ups	TRUE	-	Uint8
13-42	Logic Rule Boolean 2	null	2 set-ups	TRUE	-	Uint8
13-43	Logic Rule Operator 2	null	2 set-ups	TRUE	-	Uint8
13-44	Logic Rule Boolean 3	null	2 set-ups	TRUE	-	Uint8
13-5* States						
13-51	SL Controller Event	null	2 set-ups	TRUE	-	Uint8
13-52	SL Controller Action	null	2 set-ups	TRUE	-	Uint8

8.3.13. Special Functions 14-.*

Par. No. #	Parameter description	Default value	4-set-up	Change during operation	Conversion index	Type
14-0* Inverter Switching						
14-00	Switching Pattern	[0] 60 AVM	All set-ups	TRUE	-	Uint8
14-01	Switching Frequency	null	All set-ups	TRUE	-	Uint8
14-03	Overmodulation	[1] On	All set-ups	FALSE	-	Uint8
14-04	PWM Random	[0] Off	All set-ups	TRUE	-	Uint8
14-1* Mains On/Off						
14-12	Function at Mains Imbalance	[3] Derate	All set-ups	TRUE	-	Uint8
14-2* Reset Functions						
14-20	Reset Mode	[10] Automatic reset x 10	All set-ups	TRUE	-	Uint8
14-21	Automatic Restart Time	10 s	All set-ups	TRUE	0	Uint16
14-22	Operation Mode	[0] Normal operation	All set-ups	TRUE	-	Uint8
14-23	Typecode Setting	null	2 set-ups	FALSE	-	Uint16
14-25	Trip Delay at Torque Limit	60 s	All set-ups	TRUE	0	Uint8
14-26	Trip Delay at Inverter Fault	SR	All set-ups	TRUE	0	Uint8
14-28	Production Settings	[0] No action	All set-ups	TRUE	-	Uint8
14-29	Service Code	0 N/A	All set-ups	TRUE	0	Int32
14-3* Current Limit Ctrl.						
14-30	Current Lim Ctrl, Proportional Gain	100 %	All set-ups	FALSE	0	Uint16
14-31	Current Lim Ctrl, Integration Time	0.020 s	All set-ups	FALSE	-3	Uint16
14-4* Energy Optimising						
14-40	VT Level	66 %	All set-ups	FALSE	0	Uint8
14-41	AEO Minimum Magnetisation	40 %	All set-ups	TRUE	0	Uint8
14-42	Minimum AEO Frequency	10 Hz	All set-ups	TRUE	0	Uint8
14-43	Motor Cosphi	SR	All set-ups	TRUE	-2	Uint16
14-5* Environment						
14-50	RFI Filter	[1] On	1 set-up	FALSE	-	Uint8
14-52	Fan Control	[0] Auto	All set-ups	TRUE	-	Uint8
14-53	Fan Monitor	[1] Warning	All set-ups	TRUE	-	Uint8
14-6* Auto Derate						
14-60	Function at Over Temperature	[1] Derate	All set-ups	TRUE	-	Uint8
14-61	Function at Inverter Overload	[1] Derate	All set-ups	TRUE	-	Uint8
14-62	Inv. Overload Derate Current	95 %	All set-ups	TRUE	0	Uint16

8.3.14. FC Information 15-**

Par. No. #	Parameter description	Default value	4-set-up	Change during operation	Conversion index	Type
15-0* Operating Data						
15-00	Operating Hours	0 h	All set-ups	FALSE	74	Uint32
15-01	Running Hours	0 h	All set-ups	FALSE	74	Uint32
15-02	kWh Counter	0 kWh	All set-ups	FALSE	75	Uint32
15-03	Power Up's	0 N/A	All set-ups	FALSE	0	Uint32
15-04	Over Temp's	0 N/A	All set-ups	FALSE	0	Uint16
15-05	Over Volt's	0 N/A	All set-ups	FALSE	0	Uint16
15-06	Reset kWh Counter	[0] Do not reset	All set-ups	TRUE	-	Uint8
15-07	Reset Running Hours Counter	[0] Do not reset	All set-ups	TRUE	-	Uint8
15-08	Number of Starts	0 N/A	All set-ups	FALSE	0	Uint32
15-1* Data Log Settings						
15-10	Logging Source	0	2 set-ups	TRUE	-	Uint16
15-11	Logging Interval	SR	2 set-ups	TRUE	-3	TimD
15-12	Trigger Event	[0] False	1 set-up	TRUE	-	Uint8
15-13	Logging Mode	[0] Log always	2 set-ups	TRUE	-	Uint8
15-14	Samples Before Trigger	50 N/A	2 set-ups	TRUE	0	Uint8
15-2* Historic Log						
15-20	Historic Log: Event	0 N/A	All set-ups	FALSE	0	Uint8
15-21	Historic Log: Value	0 N/A	All set-ups	FALSE	0	Uint32
15-22	Historic Log: Time	0 ms	All set-ups	FALSE	-3	Uint32
15-23	Historic Log: Date and Time	SR	All set-ups	FALSE	0	TimeOfDay
15-3* Alarm Log						
15-30	Alarm Log: Error Code	0 N/A	All set-ups	FALSE	0	Uint8
15-31	Alarm Log: Value	0 N/A	All set-ups	FALSE	0	Uint16
15-32	Alarm Log: Time	0 s	All set-ups	FALSE	0	Uint32
15-33	Alarm Log: Date and Time	SR	All set-ups	FALSE	0	TimeOfDay
15-34	Alarm Log: Setpoint	0.000 ProcessCtrlUnit	All set-ups	FALSE	-3	Int32
15-35	Alarm Log: Feedback	0.000 ProcessCtrlUnit	All set-ups	FALSE	-3	Int32
15-36	Alarm Log: Current Demand	0 %	All set-ups	FALSE	0	Uint8
15-37	Alarm Log: Process Ctrl Unit	[0]	All set-ups	FALSE	-	Uint8
15-4* Drive Identification						
15-40	FC Type	0 N/A	All set-ups	FALSE	0	VisStr[6]
15-41	Power Section	0 N/A	All set-ups	FALSE	0	VisStr[20]
15-42	Voltage	0 N/A	All set-ups	FALSE	0	VisStr[20]
15-43	Software Version	0 N/A	All set-ups	FALSE	0	VisStr[5]
15-44	Ordered Typecode String	0 N/A	All set-ups	FALSE	0	VisStr[40]
15-45	Actual Typecode String	0 N/A	All set-ups	FALSE	0	VisStr[40]
15-46	Frequency Converter Ordering No	0 N/A	All set-ups	FALSE	0	VisStr[8]
15-47	Power Card Ordering No	0 N/A	All set-ups	FALSE	0	VisStr[8]
15-48	LCP Id No	0 N/A	All set-ups	FALSE	0	VisStr[20]
15-49	SW ID Control Card	0 N/A	All set-ups	FALSE	0	VisStr[20]
15-50	SW ID Power Card	0 N/A	All set-ups	FALSE	0	VisStr[20]
15-51	Frequency Converter Serial Number	0 N/A	All set-ups	FALSE	0	VisStr[10]
15-53	Power Card Serial Number	0 N/A	All set-ups	FALSE	0	VisStr[19]

Par. No. #	Parameter description	Default value	4-set-up	Change during operation	Conversion index	Type
15-6* Option Ident						
15-60	Option Mounted	0 N/A	All set-ups	FALSE	0	VisStr[30]
15-61	Option SW Version	0 N/A	All set-ups	FALSE	0	VisStr[20]
15-62	Option Ordering No	0 N/A	All set-ups	FALSE	0	VisStr[8]
15-63	Option Serial No	0 N/A	All set-ups	FALSE	0	VisStr[18]
15-70	Option in Slot A	0 N/A	All set-ups	FALSE	0	VisStr[30]
15-71	Slot A Option SW Version	0 N/A	All set-ups	FALSE	0	VisStr[20]
15-72	Option in Slot B	0 N/A	All set-ups	FALSE	0	VisStr[30]
15-73	Slot B Option SW Version	0 N/A	All set-ups	FALSE	0	VisStr[20]
15-74	Option in Slot C0	0 N/A	All set-ups	FALSE	0	VisStr[30]
15-75	Slot C0 Option SW Version	0 N/A	All set-ups	FALSE	0	VisStr[20]
15-76	Option in Slot C1	0 N/A	All set-ups	FALSE	0	VisStr[30]
15-77	Slot C1 Option SW Version	0 N/A	All set-ups	FALSE	0	VisStr[20]
15-9* Parameter Info						
15-92	Defined Parameters	0 N/A	All set-ups	FALSE	0	Uint16
15-93	Modified Parameters	0 N/A	All set-ups	FALSE	0	Uint16
15-99	Parameter Metadata	0 N/A	All set-ups	FALSE	0	Uint16

8.3.15. Data Readouts 16-**

Par. No. #	Parameter description	Default value	4-set-up	Change during operation	Conversion index	Type
16-0* General Status						
16-00	Control Word	0 N/A	All set-ups	FALSE	0	V2
16-01	Reference [Unit]	0.000 ReferenceFeedbackUnit	All set-ups	FALSE	-3	Int32
16-02	Reference [%]	0.0 %	All set-ups	FALSE	-1	Int16
16-03	Status Word	0 N/A	All set-ups	FALSE	0	V2
16-05	Main Actual Value [%]	0.00 %	All set-ups	FALSE	-2	N2
16-09	Custom Readout	0.00 CustomReadoutUnit	All set-ups	FALSE	-2	Int32
16-1* Motor Status						
16-10	Power [kW]	0.00 kW	All set-ups	FALSE	1	Int32
16-11	Power [hp]	0.00 hp	All set-ups	FALSE	-2	Int32
16-12	Motor Voltage	0.0 V	All set-ups	FALSE	-1	Uint16
16-13	Frequency	0.0 Hz	All set-ups	FALSE	-1	Uint16
16-14	Motor Current	0.00 A	All set-ups	FALSE	-2	Int32
16-15	Frequency [%]	0.00 %	All set-ups	FALSE	-2	N2
16-16	Torque [Nm]	0.0 Nm	All set-ups	FALSE	-1	Int32
16-17	Speed [RPM]	0 RPM	All set-ups	FALSE	67	Int32
16-18	Motor Thermal	0 %	All set-ups	FALSE	0	Int8
16-22	Torque [%]	0 %	All set-ups	FALSE	0	Int16
16-3* Drive Status						
16-30	DC Link Voltage	0 V	All set-ups	FALSE	0	Uint16
16-32	Brake Energy /s	0.000 kW	All set-ups	FALSE	0	Int32
16-33	Brake Energy /2 min	0.000 kW	All set-ups	FALSE	0	Int32
16-34	Heatsink Temp.	0 °C	All set-ups	FALSE	100	Uint8
16-35	Inverter Thermal	0 %	All set-ups	FALSE	0	Uint8
16-36	Inv. Nom. Current	SR	All set-ups	FALSE	-2	Uint32
16-37	Inv. Max. Current	SR	All set-ups	FALSE	-2	Uint32
16-38	SL Controller State	0 N/A	All set-ups	FALSE	0	Int8
16-39	Control Card Temp.	0 °C	All set-ups	FALSE	100	Uint8
16-40	Logging Buffer Full	[0] No	All set-ups	TRUE	-	Uint8
16-5* Ref. & Feedb.						
16-50	External Reference	0.0 N/A	All set-ups	FALSE	-1	Int16
16-52	Feedback [Unit]	0.000 ProcessCtrlUnit	All set-ups	FALSE	-3	Int32
16-53	Digi Pot Reference	0.00 N/A	All set-ups	FALSE	-2	Int16
16-54	Feedback 1 [Unit]	0.000 ProcessCtrlUnit	All set-ups	FALSE	-3	Int32
16-55	Feedback 2 [Unit]	0.000 ProcessCtrlUnit	All set-ups	FALSE	-3	Int32
16-56	Feedback 3 [Unit]	0.000 ProcessCtrlUnit	All set-ups	FALSE	-3	Int32
16-59	Adjusted Setpoint	0.000 ProcessCtrlUnit	All set-ups	FALSE	-3	Int32

Par. No. #	Parameter description	Default value	4-set-up	Change during operation	Conversion index	Type
16-6* Inputs & Outputs						
16-60	Digital Input	0 N/A	All set-ups	FALSE	0	UInt16
16-61	Terminal 53 Switch Setting	[0] Current	All set-ups	FALSE	-	UInt8
16-62	Analog Input 53	0.000 N/A	All set-ups	FALSE	-3	Int32
16-63	Terminal 54 Switch Setting	[0] Current	All set-ups	FALSE	-	UInt8
16-64	Analog Input 54	0.000 N/A	All set-ups	FALSE	-3	Int32
16-65	Analog Output 42 [mA]	0.000 N/A	All set-ups	FALSE	-3	Int16
16-66	Digital Output [bin]	0 N/A	All set-ups	FALSE	0	Int16
16-67	Pulse Input #29 [Hz]	0 N/A	All set-ups	FALSE	0	Int32
16-68	Pulse Input #33 [Hz]	0 N/A	All set-ups	FALSE	0	Int32
16-69	Pulse Output #27 [Hz]	0 N/A	All set-ups	FALSE	0	Int32
16-70	Pulse Output #29 [Hz]	0 N/A	All set-ups	FALSE	0	Int32
16-71	Relay Output [bin]	0 N/A	All set-ups	FALSE	0	Int16
16-72	Counter A	0 N/A	All set-ups	TRUE	0	Int32
16-73	Counter B	0 N/A	All set-ups	TRUE	0	Int32
16-75	Analog In X30/11	0.000 N/A	All set-ups	FALSE	-3	Int32
16-76	Analog In X30/12	0.000 N/A	All set-ups	FALSE	-3	Int32
16-77	Analog Out X30/8 [mA]	0.000 N/A	All set-ups	FALSE	-3	Int16
16-8* Fieldbus & FC Port						
16-80	Fieldbus CTW 1	0 N/A	All set-ups	FALSE	0	V2
16-82	Fieldbus REF 1	0 N/A	All set-ups	FALSE	0	N2
16-84	Comm. Option STW	0 N/A	All set-ups	FALSE	0	V2
16-85	FC Port CTW 1	0 N/A	All set-ups	FALSE	0	V2
16-86	FC Port REF 1	0 N/A	All set-ups	FALSE	0	N2
16-9* Diagnosis Readouts						
16-90	Alarm Word	0 N/A	All set-ups	FALSE	0	UInt32
16-91	Alarm Word 2	0 N/A	All set-ups	FALSE	0	UInt32
16-92	Warning Word	0 N/A	All set-ups	FALSE	0	UInt32
16-93	Warning Word 2	0 N/A	All set-ups	FALSE	0	UInt32
16-94	Ext. Status Word	0 N/A	All set-ups	FALSE	0	UInt32
16-95	Ext. Status Word 2	0 N/A	All set-ups	FALSE	0	UInt32
16-96	Maintenance Word	0 N/A	All set-ups	FALSE	0	UInt32

8.3.16. Data Readouts 2 18- **

Par. No. #	Parameter description	Default value	4-set-up	Change during operation	Conversion index	Type
18-0* Maintenance Log						
18-00	Maintenance Log: Item	0 N/A	All set-ups	FALSE	0	Uint8
18-01	Maintenance Log: Action	0 N/A	All set-ups	FALSE	0	Uint8
18-02	Maintenance Log: Time	0 s	All set-ups	FALSE	0	Uint32
18-03	Maintenance Log: Date and Time	SR	All set-ups	FALSE	0	TimeOfDay
18-3* Inputs & Outputs						
18-30	Analog Input X42/1	0.000 N/A	All set-ups	FALSE	-3	Int32
18-31	Analog Input X42/3	0.000 N/A	All set-ups	FALSE	-3	Int32
18-32	Analog Input X42/5	0.000 N/A	All set-ups	FALSE	-3	Int32
18-33	Analog Out X42/7 [V]	0.000 N/A	All set-ups	FALSE	-3	Int16
18-34	Analog Out X42/9 [V]	0.000 N/A	All set-ups	FALSE	-3	Int16
18-35	Analog Out X42/11 [V]	0.000 N/A	All set-ups	FALSE	-3	Int16

8.3.17. FC Closed Loop 20-.*

Par. No. #	Parameter description	Default value	4-set-up	Change during operation	Conversion index	Type
20-0* Feedback						
20-00	Feedback 1 Source	[2] Analog input: 54	All set-ups	TRUE	-	Uint8
20-01	Feedback 1 Conversion	[0] Linear	All set-ups	FALSE	-	Uint8
20-02	Feedback 1 Source Unit	null	All set-ups	TRUE	-	Uint8
20-03	Feedback 2 Source	[0] No function	All set-ups	TRUE	-	Uint8
20-04	Feedback 2 Conversion	[0] Linear	All set-ups	FALSE	-	Uint8
20-05	Feedback 2 Source Unit	null	All set-ups	TRUE	-	Uint8
20-06	Feedback 3 Source	[0] No function	All set-ups	TRUE	-	Uint8
20-07	Feedback 3 Conversion	[0] Linear	All set-ups	FALSE	-	Uint8
20-08	Feedback 3 Source Unit	null	All set-ups	TRUE	-	Uint8
20-12	Reference/Feedback Unit	null	All set-ups	TRUE	-	Uint8
20-2* Feedback & Setpoint						
20-20	Feedback Function	[4] Maximum	All set-ups	TRUE	-	Uint8
20-21	Setpoint 1	0.000 ProcessCtrlUnit	All set-ups	TRUE	-3	Int32
20-22	Setpoint 2	0.000 ProcessCtrlUnit	All set-ups	TRUE	-3	Int32
20-23	Setpoint 3	0.000 ProcessCtrlUnit	All set-ups	TRUE	-3	Int32
20-8* PID Basic Settings						
20-81	PID Normal/ Inverse Control	[0] Normal	All set-ups	TRUE	-	Uint8
20-82	PID Start Speed [RPM]	SR	All set-ups	TRUE	67	Uint16
20-83	PID Start Speed [Hz]	SR	All set-ups	TRUE	-1	Uint16
20-84	On Reference Bandwidth	5 %	All set-ups	TRUE	0	Uint8
20-9* PID Controller						
20-91	PID Anti Windup	[1] On	All set-ups	TRUE	-	Uint8
20-93	PID Proportional Gain	2.00 N/A	All set-ups	TRUE	-2	Uint16
20-94	PID Integral Time	8.00 s	All set-ups	TRUE	-2	Uint32
20-95	PID Differentiation Time	0.00 s	All set-ups	TRUE	-2	Uint16
20-96	PID Diff. Gain Limit	5.0 N/A	All set-ups	TRUE	-1	Uint16

8.3.18. Ext. Closed Loop 21-*

Par. No. #	Parameter description	Default value	4-set-up	Change during operation	Conversion index	Type
21-1* Ext. CL 1 Ref./Fb.						
21-10	Ext. 1 Ref./Feedback Unit	[0]	All set-ups	TRUE	-	Uint8
21-11	Ext. 1 Minimum Reference	0.000 ExtPID1Unit	All set-ups	TRUE	-3	Int32
21-12	Ext. 1 Maximum Reference	100.000 ExtPID1Unit	All set-ups	TRUE	-3	Int32
21-13	Ext. 1 Reference Source	[0] No function	All set-ups	TRUE	-	Uint8
21-14	Ext. 1 Feedback Source	[0] No function	All set-ups	TRUE	-	Uint8
21-15	Ext. 1 Setpoint	0.000 ExtPID1Unit	All set-ups	TRUE	-3	Int32
21-17	Ext. 1 Reference [Unit]	0.000 ExtPID1Unit	All set-ups	TRUE	-3	Int32
21-18	Ext. 1 Feedback [Unit]	0.000 ExtPID1Unit	All set-ups	TRUE	-3	Int32
21-19	Ext. 1 Output [%]	0 %	All set-ups	TRUE	0	Int32
21-2* Ext. CL 1 PID						
21-20	Ext. 1 Normal/Inverse Control	[0] Normal	All set-ups	TRUE	-	Uint8
21-21	Ext. 1 Proportional Gain	0.50 N/A	All set-ups	TRUE	-2	Uint16
21-22	Ext. 1 Integral Time	20.00 s	All set-ups	TRUE	-2	Uint32
21-23	Ext. 1 Differentiation Time	0.00 s	All set-ups	TRUE	-2	Uint16
21-24	Ext. 1 Dif. Gain Limit	5.0 N/A	All set-ups	TRUE	-1	Uint16
21-3* Ext. CL 2 Ref./Fb.						
21-30	Ext. 2 Ref./Feedback Unit	[0]	All set-ups	TRUE	-	Uint8
21-31	Ext. 2 Minimum Reference	0.000 ExtPID2Unit	All set-ups	TRUE	-3	Int32
21-32	Ext. 2 Maximum Reference	100.000 ExtPID2Unit	All set-ups	TRUE	-3	Int32
21-33	Ext. 2 Reference Source	[0] No function	All set-ups	TRUE	-	Uint8
21-34	Ext. 2 Feedback Source	[0] No function	All set-ups	TRUE	-	Uint8
21-35	Ext. 2 Setpoint	0.000 ExtPID2Unit	All set-ups	TRUE	-3	Int32
21-37	Ext. 2 Reference [Unit]	0.000 ExtPID2Unit	All set-ups	TRUE	-3	Int32
21-38	Ext. 2 Feedback [Unit]	0.000 ExtPID2Unit	All set-ups	TRUE	-3	Int32
21-39	Ext. 2 Output [%]	0 %	All set-ups	TRUE	0	Int32
21-4* Ext. CL 2 PID						
21-40	Ext. 2 Normal/Inverse Control	[0] Normal	All set-ups	TRUE	-	Uint8
21-41	Ext. 2 Proportional Gain	0.50 N/A	All set-ups	TRUE	-2	Uint16
21-42	Ext. 2 Integral Time	20.00 s	All set-ups	TRUE	-2	Uint32
21-43	Ext. 2 Differentiation Time	0.00 s	All set-ups	TRUE	-2	Uint16
21-44	Ext. 2 Dif. Gain Limit	5.0 N/A	All set-ups	TRUE	-1	Uint16
21-5* Ext. CL 3 Ref./Fb.						
21-50	Ext. 3 Ref./Feedback Unit	[0]	All set-ups	TRUE	-	Uint8
21-51	Ext. 3 Minimum Reference	0.000 ExtPID3Unit	All set-ups	TRUE	-3	Int32
21-52	Ext. 3 Maximum Reference	100.000 ExtPID3Unit	All set-ups	TRUE	-3	Int32
21-53	Ext. 3 Reference Source	[0] No function	All set-ups	TRUE	-	Uint8
21-54	Ext. 3 Feedback Source	[0] No function	All set-ups	TRUE	-	Uint8
21-55	Ext. 3 Setpoint	0.000 ExtPID3Unit	All set-ups	TRUE	-3	Int32
21-57	Ext. 3 Reference [Unit]	0.000 ExtPID3Unit	All set-ups	TRUE	-3	Int32
21-58	Ext. 3 Feedback [Unit]	0.000 ExtPID3Unit	All set-ups	TRUE	-3	Int32
21-59	Ext. 3 Output [%]	0 %	All set-ups	TRUE	0	Int32
21-6* Ext. CL 3 PID						
21-60	Ext. 3 Normal/Inverse Control	[0] Normal	All set-ups	TRUE	-	Uint8
21-61	Ext. 3 Proportional Gain	0.50 N/A	All set-ups	TRUE	-2	Uint16
21-62	Ext. 3 Integral Time	20.00 s	All set-ups	TRUE	-2	Uint32
21-63	Ext. 3 Differentiation Time	0.00 s	All set-ups	TRUE	-2	Uint16
21-64	Ext. 3 Dif. Gain Limit	5.0 N/A	All set-ups	TRUE	-1	Uint16

8.3.19. Application Functions 22-*

Par. No. #	Parameter description	Default value	4-set-up	Change during operation	Conversion index	Type
22-0* Miscellaneous						
22-00	External Interlock Delay	0 s	All set-ups	TRUE	0	Uint16
22-2* No-Flow Detection						
22-20	Low Power Auto Set-up	[0] Off	All set-ups	FALSE	-	Uint8
22-21	Low Power Detection	[0] Disabled	All set-ups	TRUE	-	Uint8
22-22	Low Speed Detection	[0] Disabled	All set-ups	TRUE	-	Uint8
22-23	No-Flow Function	[0] Off	All set-ups	TRUE	-	Uint8
22-24	No-Flow Delay	10 s	All set-ups	TRUE	0	Uint16
22-26	Dry Pump Function	[0] Off	All set-ups	TRUE	-	Uint8
22-27	Dry Pump Delay	10 s	All set-ups	TRUE	0	Uint16
22-3* No-Flow Power Tuning						
22-30	No-Flow Power	0.00 kW	All set-ups	TRUE	1	Uint32
22-31	Power Correction Factor	100 %	All set-ups	TRUE	0	Uint16
22-32	Low Speed [RPM]	SR	All set-ups	TRUE	67	Uint16
22-33	Low Speed [Hz]	SR	All set-ups	TRUE	-1	Uint16
22-34	Low Speed Power [kW]	SR	All set-ups	TRUE	1	Uint32
22-35	Low Speed Power [HP]	SR	All set-ups	TRUE	-2	Uint32
22-36	High Speed [RPM]	SR	All set-ups	TRUE	67	Uint16
22-37	High Speed [Hz]	SR	All set-ups	TRUE	-1	Uint16
22-38	High Speed Power [kW]	SR	All set-ups	TRUE	1	Uint32
22-39	High Speed Power [HP]	SR	All set-ups	TRUE	-2	Uint32
22-4* Sleep Mode						
22-40	Minimum Run Time	60 s	All set-ups	TRUE	0	Uint16
22-41	Minimum Sleep Time	30 s	All set-ups	TRUE	0	Uint16
22-42	Wake-up Speed [RPM]	SR	All set-ups	TRUE	67	Uint16
22-43	Wake-up Speed [Hz]	SR	All set-ups	TRUE	-1	Uint16
22-44	Wake-up Ref./FB Difference	10 %	All set-ups	TRUE	0	Int8
22-45	Setpoint Boost	0 %	All set-ups	TRUE	0	Int8
22-46	Maximum Boost Time	60 s	All set-ups	TRUE	0	Uint16
22-5* End of Curve						
22-50	End of Curve Function	[0] Off	All set-ups	TRUE	-	Uint8
22-51	End of Curve Delay	10 s	All set-ups	TRUE	0	Uint16
22-6* Broken Belt Detection						
22-60	Broken Belt Function	[0] Off	All set-ups	TRUE	-	Uint8
22-61	Broken Belt Torque	10 %	All set-ups	TRUE	0	Uint8
22-62	Broken Belt Delay	10 s	All set-ups	TRUE	0	Uint16
22-7* Short Cycle Protection						
22-75	Short Cycle Protection	[0] Disabled	All set-ups	TRUE	-	Uint8
22-76	Interval between Starts	start_to_start_min_on_time (P2277)	All set-ups	TRUE	0	Uint16
22-77	Minimum Run Time	0 s	All set-ups	TRUE	0	Uint16

Par. No. #	Parameter description	Default value	4-set-up	Change during operation	Conversion index	Type
22-8* Flow Compensation						
22-80	Flow Compensation	[0] Disabled	All set-ups	TRUE	-	Uint8
22-81	Square-linear Curve Approximation	100 %	All set-ups	TRUE	0	Uint8
22-82	Work Point Calculation	[0] Disabled	All set-ups	TRUE	-	Uint8
22-83	Speed at No-Flow [RPM]	SR	All set-ups	TRUE	67	Uint16
22-84	Speed at No-Flow [Hz]	SR	All set-ups	TRUE	-1	Uint16
22-85	Speed at Design Point [RPM]	SR	All set-ups	TRUE	67	Uint16
22-86	Speed at Design Point [Hz]	SR	All set-ups	TRUE	-1	Uint16
22-87	Pressure at No-Flow Speed	0.000 N/A	All set-ups	TRUE	-3	Int32
22-88	Pressure at Rated Speed	999999.999 N/A	All set-ups	TRUE	-3	Int32
22-89	Flow at Design Point	0.000 N/A	All set-ups	TRUE	-3	Int32
22-90	Flow at Rated Speed	0.000 N/A	All set-ups	TRUE	-3	Int32

8.3.20. Timed Actions 23- **

Par. No. #	Parameter description	Default value	4-set-up	Change during operation	Conversion index	Type
23-0* Timed Actions						
23-00	ON Time	SR	2 set-ups	TRUE	0	TimeOfDay- WoDate
23-01	ON Action	[0] Disabled	2 set-ups	TRUE	-	Uint8
23-02	OFF Time	SR	2 set-ups	TRUE	0	TimeOfDay- WoDate
23-03	OFF Action	[0] Disabled	2 set-ups	TRUE	-	Uint8
23-04	Occurrence	[0] All days	2 set-ups	TRUE	-	Uint8
23-1* Maintenance						
23-10	Maintenance Item	[1] Motor bearings	1 set-up	TRUE	-	Uint8
23-11	Maintenance Action	[1] Lubricate	1 set-up	TRUE	-	Uint8
23-12	Maintenance Time Base	[0] Disabled	1 set-up	TRUE	-	Uint8
23-13	Maintenance Time Interval	1 h	1 set-up	TRUE	74	Uint32
23-14	Maintenance Date and Time	SR	1 set-up	TRUE	0	TimeOfDay
23-1* Maintenance Reset						
23-15	Reset Maintenance Word	[0] Do not reset	All set-ups	TRUE	-	Uint8
23-5* Energy Log						
23-50	Energy Log Resolution	[5] Last 24 Hours	2 set-ups	TRUE	-	Uint8
23-51	Period Start	SR	2 set-ups	TRUE	0	TimeOfDay
23-53	Energy Log	0 N/A	All set-ups	TRUE	0	Uint32
23-54	Reset Energy Log	[0] Do not reset	All set-ups	TRUE	-	Uint8
23-6* Trending						
23-60	Trend Variable	[0] Power [kW]	2 set-ups	TRUE	-	Uint8
23-61	Continuous Bin Data	0 N/A	All set-ups	TRUE	0	Uint32
23-62	Timed Bin Data	0 N/A	All set-ups	TRUE	0	Uint32
23-63	Timed Period Start	SR	2 set-ups	TRUE	0	TimeOfDay
23-64	Timed Period Stop	SR	2 set-ups	TRUE	0	TimeOfDay
23-65	Minimum Bin Value	SR	2 set-ups	TRUE	0	Uint8
23-66	Reset Continuous Bin Data	[0] Do not reset	All set-ups	TRUE	-	Uint8
23-67	Reset Timed Bin Data	[0] Do not reset	All set-ups	TRUE	-	Uint8
23-8* Payback Counter						
23-80	Power Reference Factor	100 %	2 set-ups	TRUE	0	Uint8
23-81	Energy Cost	1.00 N/A	2 set-ups	TRUE	-2	Uint32
23-82	Investment	0 N/A	2 set-ups	TRUE	0	Uint32
23-83	Energy Savings	0 kWh	All set-ups	TRUE	75	Int32
23-84	Cost Savings	0 N/A	All set-ups	TRUE	0	Int32

8.3.21. Cascade Controller 25- **

Par. No. #	Parameter description	Default value	4-set-up	Change during operation	Conversion index	Type
25-0* System Settings						
25-00	Cascade Controller	null	2 set-ups	FALSE	-	Uint8
25-02	Motor Start	[0] Direct on Line	2 set-ups	FALSE	-	Uint8
25-04	Pump Cycling	null	All set-ups	TRUE	-	Uint8
25-05	Fixed Lead Pump	null	2 set-ups	FALSE	-	Uint8
25-06	Number of Pumps	2 N/A	2 set-ups	FALSE	0	Uint8
25-2* Bandwidth Settings						
25-20	Staging Bandwidth	SR	All set-ups	TRUE	0	Uint8
25-21	Override Bandwidth	100 %	All set-ups	TRUE	0	Uint8
25-22	Fixed Speed Bandwidth	casco_staging_bandwidth (P2520)	All set-ups	TRUE	0	Uint8
25-23	SBW Staging Delay	15 s	All set-ups	TRUE	0	Uint16
25-24	SBW Destaging Delay	15 s	All set-ups	TRUE	0	Uint16
25-25	OBW Time	10 s	All set-ups	TRUE	0	Uint16
25-26	Destage At No-Flow	[0] Disabled	All set-ups	TRUE	-	Uint8
25-27	Stage Function	null	All set-ups	TRUE	-	Uint8
25-28	Stage Function Time	15 s	All set-ups	TRUE	0	Uint16
25-29	Destage Function	null	All set-ups	TRUE	-	Uint8
25-30	Destage Function Time	15 s	All set-ups	TRUE	0	Uint16
25-4* Staging Settings						
25-40	Ramp Down Delay	10.0 s	All set-ups	TRUE	-1	Uint16
25-41	Ramp Up Delay	2.0 s	All set-ups	TRUE	-1	Uint16
25-42	Staging Threshold	SR	All set-ups	TRUE	0	Uint8
25-43	Destaging Threshold	SR	All set-ups	TRUE	0	Uint8
25-44	Staging Speed [RPM]	0 RPM	All set-ups	TRUE	67	Uint16
25-45	Staging Speed [Hz]	0.0 Hz	All set-ups	TRUE	-1	Uint16
25-46	Destaging Speed [RPM]	0 RPM	All set-ups	TRUE	67	Uint16
25-47	Destaging Speed [Hz]	0.0 Hz	All set-ups	TRUE	-1	Uint16
25-5* Alternation Settings						
25-50	Lead Pump Alternation	null	All set-ups	TRUE	-	Uint8
25-51	Alternation Event	[0] External	All set-ups	TRUE	-	Uint8
25-52	Alternation Time Interval	24 h	All set-ups	TRUE	74	Uint16
25-53	Alternation Timer Value	0 N/A	All set-ups	TRUE	0	VisStr[7]
25-54	Alternation Predefined Time	SR	All set-ups	TRUE	0	TimeOfDay-
25-55	Alternate if Load < 50%	[1] Enabled	All set-ups	TRUE	-	WoDate
25-56	Staging Mode at Alternation	[0] Slow	All set-ups	TRUE	-	Uint8
25-58	Run Next Pump Delay	0.1 s	All set-ups	TRUE	-1	Uint16
25-59	Run on Mains Delay	0.5 s	All set-ups	TRUE	-1	Uint16

Par. No. #	Parameter description	Default value	4-set-up	Change during operation	Conversion index	Type
25-8* Status						
25-80	Cascade Status	0 N/A	All set-ups	TRUE	0	VisStr[25]
25-81	Pump Status	0 N/A	All set-ups	TRUE	0	VisStr[25]
25-82	Lead Pump	0 N/A	All set-ups	TRUE	0	Uint8
25-83	Relay Status	0 N/A	All set-ups	TRUE	0	VisStr[4]
25-84	Pump ON Time	0 h	All set-ups	TRUE	74	Uint32
25-85	Relay ON Time	0 h	All set-ups	TRUE	74	Uint32
25-86	Reset Relay Counters	[0] Do not reset	All set-ups	TRUE	-	Uint8
25-9* Service						
25-90	Pump Interlock	[0] Off	All set-ups	TRUE	-	Uint8
25-91	Manual Alternation	0 N/A	All set-ups	TRUE	0	Uint8

8.3.22. Analog I/O Option MCB 109 26-**

Par. No. #	Parameter description	Default value	4-set-up	Change during operation	Conversion index	Type
26-0* Analog I/O Mode						
26-00	Terminal X42/1 Mode	[1] Voltage	All set-ups	TRUE	-	Uint8
26-01	Terminal X42/3 Mode	[1] Voltage	All set-ups	TRUE	-	Uint8
26-02	Terminal X42/5 Mode	[1] Voltage	All set-ups	TRUE	-	Uint8
26-1* Analog Input X42/1						
26-10	Terminal X42/1 Low Voltage	0.07 V	All set-ups	TRUE	-2	Int16
26-11	Terminal X42/1 High Voltage	10.00 V	All set-ups	TRUE	-2	Int16
26-14	Term. X42/1 Low Ref./Feedb. Value	0.000 N/A	All set-ups	TRUE	-3	Int32
26-15	Term. X42/1 High Ref./Feedb. Value	100.000 N/A	All set-ups	TRUE	-3	Int32
26-16	Term. X42/1 Filter Time Constant	0.001 s	All set-ups	TRUE	-3	Uint16
26-17	Term. X42/1 Live Zero	[1] Enabled	All set-ups	TRUE	-	Uint8
26-2* Analog Input X42/3						
26-20	Terminal X42/3 Low Voltage	0.07 V	All set-ups	TRUE	-2	Int16
26-21	Terminal X42/3 High Voltage	10.00 V	All set-ups	TRUE	-2	Int16
26-24	Term. X42/3 Low Ref./Feedb. Value	0.000 N/A	All set-ups	TRUE	-3	Int32
26-25	Term. X42/3 High Ref./Feedb. Value	100.000 N/A	All set-ups	TRUE	-3	Int32
26-26	Term. X42/3 Filter Time Constant	0.001 s	All set-ups	TRUE	-3	Uint16
26-27	Term. X42/3 Live Zero	[1] Enabled	All set-ups	TRUE	-	Uint8
26-3* Analog Input X42/5						
26-30	Terminal X42/5 Low Voltage	0.07 V	All set-ups	TRUE	-2	Int16
26-31	Terminal X42/5 High Voltage	10.00 V	All set-ups	TRUE	-2	Int16
26-34	Term. X42/5 Low Ref./Feedb. Value	0.000 N/A	All set-ups	TRUE	-3	Int32
26-35	Term. X42/5 High Ref./Feedb. Value	100.000 N/A	All set-ups	TRUE	-3	Int32
26-36	Term. X42/5 Filter Time Constant	0.001 s	All set-ups	TRUE	-3	Uint16
26-37	Term. X42/5 Live Zero	[1] Enabled	All set-ups	TRUE	-	Uint8
26-4* Analog Output X42/7						
26-40	Terminal X42/7 Output	[0] No operation	All set-ups	TRUE	-	Uint8
26-41	Terminal X42/7 Min. Scale	0.00 %	All set-ups	TRUE	-2	Int16
26-42	Terminal X42/7 Max. Scale	100.00 %	All set-ups	TRUE	-2	Int16
26-43	Terminal X42/7 Output Bus Control	0.00 %	All set-ups	TRUE	-2	N2
26-44	Terminal X42/7 Output Timeout Preset	0.00 %	1 set-up	TRUE	-2	Uint16
26-5* Analog Output X42/9						
26-50	Terminal X42/9 Output	[0] No operation	All set-ups	TRUE	-	Uint8
26-51	Terminal X42/9 Min. Scale	0.00 %	All set-ups	TRUE	-2	Int16
26-52	Terminal X42/9 Max. Scale	100.00 %	All set-ups	TRUE	-2	Int16
26-53	Terminal X42/9 Output Bus Control	0.00 %	All set-ups	TRUE	-2	N2
26-54	Terminal X42/9 Output Timeout Preset	0.00 %	1 set-up	TRUE	-2	Uint16
26-6* Analog Output X42/11						
26-60	Terminal X42/11 Output	[0] No operation	All set-ups	TRUE	-	Uint8
26-61	Terminal X42/11 Min. Scale	0.00 %	All set-ups	TRUE	-2	Int16
26-62	Terminal X42/11 Max. Scale	100.00 %	All set-ups	TRUE	-2	Int16
26-63	Terminal X42/11 Output Bus Control	0.00 %	All set-ups	TRUE	-2	N2
26-64	Terminal X42/11 Output Timeout Preset	0.00 %	1 set-up	TRUE	-2	Uint16

8.3.23. Cascade CTL Option 27-.* *

Par. No. #	Parameter description	Default value	4-set-up	Change during operation	Conversion index	Type
27-0* Control & Status						
27-01	Pump Status	[0] Ready	All set-ups	TRUE	-	Uint8
27-02	Manual Pump Control	[0] No Operation	2 set-ups	TRUE	-	Uint8
27-03	Current Runtime Hours	0 h	All set-ups	TRUE	74	Uint32
27-04	Pump Total Lifetime Hours	0 h	All set-ups	TRUE	74	Uint32
27-1* Configuration						
27-10	Cascade Controller	[0] Disabled	2 set-ups	FALSE	-	Uint8
27-11	Number Of Drives	1 N/A	2 set-ups	FALSE	0	Uint8
27-12	Number Of Pumps	SR	2 set-ups	FALSE	0	Uint8
27-14	Pump Capacity	100 %	2 set-ups	FALSE	0	Uint16
27-16	Runtime Balancing	[0] Balanced Priority 1	2 set-ups	TRUE	-	Uint8
27-17	Motor Starters	[0] Direct Online	2 set-ups	FALSE	-	Uint8
27-18	Spin Time for Unused Pumps	SR	All set-ups	TRUE	0	Uint16
27-19	Reset Current Runtime Hours	[0] Do not reset	All set-ups	TRUE	-	Uint8
27-2* Bandwidth Settings						
27-20	Normal Operating Range	SR	All set-ups	TRUE	0	Uint8
27-21	Override Limit	100 %	All set-ups	TRUE	0	Uint8
27-22	Fixed Speed Only Operating Range	SR	All set-ups	TRUE	0	Uint8
27-23	Staging Delay	15 s	All set-ups	TRUE	0	Uint16
27-24	Destaging Delay	15 s	All set-ups	TRUE	0	Uint16
27-25	Override Hold Time	10 s	All set-ups	TRUE	0	Uint16
27-27	Min Speed Destage Delay	SR	All set-ups	TRUE	0	Uint16
27-3* Staging Speed						
27-31	Stage On Speed [RPM]	SR	All set-ups	TRUE	67	Uint16
27-32	Stage On Speed [Hz]	SR	All set-ups	TRUE	-1	Uint16
27-33	Stage Off Speed [RPM]	SR	All set-ups	TRUE	67	Uint16
27-34	Stage Off Speed [Hz]	SR	All set-ups	TRUE	-1	Uint16
27-4* Staging Settings						
27-40	Automatic Staging/Destaging	[0] Disabled	All set-ups	FALSE	-	Uint8
27-41	Ramp Down Delay	10.0 s	All set-ups	TRUE	-1	Uint16
27-42	Ramp Up Delay	2.0 s	All set-ups	TRUE	-1	Uint16
27-43	Staging Threshold	SR	All set-ups	TRUE	0	Uint8
27-44	Destaging Threshold	SR	All set-ups	TRUE	0	Uint8
27-45	Staging Speed [RPM]	0 RPM	All set-ups	TRUE	67	Uint16
27-46	Staging Speed [Hz]	0.0 Hz	All set-ups	TRUE	-1	Uint16
27-47	Destaging Speed [RPM]	0 RPM	All set-ups	TRUE	67	Uint16
27-48	Destaging Speed [Hz]	0.0 Hz	All set-ups	TRUE	-1	Uint16
27-5* Alternate Settings						
27-50	Automatic Alternation	[0] Disabled	All set-ups	FALSE	-	Uint8
27-51	Alternation Event	null	All set-ups	TRUE	-	Uint8
27-52	Alternation Time Interval	0 min	All set-ups	TRUE	70	Uint16
27-53	Alternation Timer Value	0 min	All set-ups	TRUE	70	Uint16
27-54	Alternation At Time of Day	[0] Disabled	All set-ups	TRUE	-	Uint8
27-55	Alternation Predefined Time	SR	All set-ups	TRUE	0	TimeOfDay-
27-56	Alternate Capacity is <	0 %	All set-ups	TRUE	0	WoDate
27-58	Run Next Pump Delay	0.1 s	All set-ups	TRUE	-1	Uint16
27-7* Connections						
27-70	Relay	[0] Standard Relay	2 set-ups	FALSE	-	Uint8
27-9* Readouts						
27-91	Cascade Reference	0.0 %	All set-ups	TRUE	-1	Uint16
27-92	% Of Total Capacity	0 %	All set-ups	TRUE	0	Uint16
27-93	Cascade Option Status	[0] Disabled	All set-ups	TRUE	-	Uint8

8.3.24. Water Application Functions 29-.*.*

Par. No. #	Parameter description	Default value	4-set-up	Change during operation	Conversion index	Type
29-0* Pipe Fill						
29-00	Pipe Fill Enable	[0] Disabled	2 set-ups	FALSE	-	Uint8
29-01	Pipe Fill Speed [RPM]	SR	All set-ups	TRUE	67	Uint16
29-02	Pipe Fill Speed [Hz]	SR	All set-ups	TRUE	-1	Uint16
29-03	Pipe Fill Time	0.00 s	All set-ups	TRUE	-2	Uint32
29-04	Pipe Fill Rate	0.001 ProcessCtrlUnit	All set-ups	TRUE	-3	Int32
29-05	Filled Setpoint	0.000 ProcessCtrlUnit	All set-ups	TRUE	-3	Int32

8.3.25. Bypass Option 31 - * *

Par. No. #	Parameter description	Default value	4-set-up	Change during operation	Conversion index	Type
31-00	Bypass Mode	[0] Drive	All set-ups	TRUE	-	Uint8
31-01	Bypass Start Time Delay	30 s	All set-ups	TRUE	0	Uint16
31-02	Bypass Trip Time Delay	0 s	All set-ups	TRUE	0	Uint16
31-03	Test Mode Activation	[0] Disabled	All set-ups	TRUE	-	Uint8
31-10	Bypass Status Word	0 N/A	All set-ups	FALSE	0	V2
31-11	Bypass Running Hours	0 h	All set-ups	FALSE	74	Uint32
31-19	Remote Bypass Activation	[0] Disabled	2 set-ups	TRUE	-	Uint8

9. Troubleshooting

9.1. Alarms and warnings

A warning or an alarm is signalled by the relevant LED on the front of the frequency converter and indicated by a code on the display.

A warning remains active until its cause is no longer present. Under certain circumstances operation of the motor may still be continued. Warning messages may be critical, but are not necessarily so.

In the event of an alarm, the frequency converter will have tripped. Alarms must be reset to restart operation once their cause has been rectified.

This may be done in four ways:

1. By using the [RESET] control button on the LCP control panel.
2. Via a digital input with the "Reset" function.
3. Via serial communication/optional fieldbus.
4. By resetting automatically using the [Auto Reset] function, which is a default setting for VLT AQUA Drive. see par. 14-20 Reset Mode in [VLT AQUA Drive Programming Guide](#)



NB!

After a manual reset using the [RESET] button on the LCP, the [AUTO ON] or [HAND ON] button must be pressed to restart the motor.

If an alarm cannot be reset, the reason may be that its cause has not been rectified, or the alarm is trip-locked (see also table on following page).

Alarms that are trip-locked offer additional protection, means that the mains supply must be switched off before the alarm can be reset. After being switched back on, the frequency converter is no longer blocked and may be reset as described above once the cause has been rectified.

Alarms that are not trip-locked can also be reset using the automatic reset function in parameter 14-20 (Warning: automatic wake-up is possible!)

If a warning and alarm is marked against a code in the table on the following page, this means that either a warning occurs before an alarm, or it can be specified whether it is a warning or an alarm that is to be displayed for a given fault.

This is possible, for instance, in parameter 1-90 *Motor Thermal Protection*. After an alarm or trip, the motor carries on coasting, and the alarm and warning flash on the frequency converter. Once the problem has been rectified, only the alarm continues flashing.

No.	Description	Warning	Alarm/Trip	Alarm/Trip Lock	Parameter Reference
1	10 Volts low	X			
2	Live zero error	(X)	(X)		6-01
3	No motor	(X)			1-80
4	Mains phase loss	(X)	(X)	(X)	14-12
5	DC link voltage high	X			
6	DC link voltage low	X			
7	DC over voltage	X	X		
8	DC under voltage	X	X		
9	Inverter overloaded	X	X		
10	Motor ETR over temperature	(X)	(X)		1-90
11	Motor thermistor over temperature	(X)	(X)		1-90
12	Torque limit	X	X		
13	Over Current	X	X	X	
14	Earth fault	X	X	X	
15	Hardware mesh mash		X	X	
16	Short Circuit		X	X	
17	Control word timeout	(X)	(X)		8-04
25	Brake resistor short-circuited	X			
26	Brake resistor power limit	(X)	(X)		2-13
27	Brake chopper short-circuited	X	X		
28	Brake check	(X)	(X)		2-15
29	Power board over temp	X	X	X	
30	Motor phase U missing	(X)	(X)	(X)	4-58
31	Motor phase V missing	(X)	(X)	(X)	4-58
32	Motor phase W missing	(X)	(X)	(X)	4-58
33	Inrush fault		X	X	
34	Fieldbus communication fault	X	X		
38	Internal fault		X	X	
47	24 V supply low	X	X	X	
48	1.8 V supply low		X	X	
50	AMA calibration failed		X		
51	AMA check I_{nom} and I_{nom}		X		
52	AMA low I_{nom}		X		
53	AMA motor too big		X		
54	AMA motor too small		X		
55	AMA parameter out of range		X		
56	AMA interrupted by user		X		
57	AMA timeout		X		
58	AMA internal fault	X	X		
59	Current limit	X			
61	Tracking Error	(X)	(X)		4-30
62	Output Frequency at Maximum Limit	X			
64	Voltage Limit	X			
65	Control Board Over-temperature	X	X	X	
66	Heat sink Temperature Low	X			
67	Option Configuration has Changed		X		
68	Safe Stop Activated		X		
80	Drive Initialised to Default Value		X		

Table 9.1: Alarm/Warning code list

(X) Dependent on parameter

<i>LED indication</i>	
Warning	yellow
Alarm	flashing red
Trip locked	yellow and red

Alarm Word and Extended Status Word					
Bit	Hex	Dec	Alarm Word	Warning Word	Extended Status Word
0	00000001	1	Brake Check	Brake Check	Ramping
1	00000002	2	Pwr. Card Temp	Pwr. Card Temp	AMA Running
2	00000004	4	Earth Fault	Earth Fault	Start CW/CCW
3	00000008	8	Ctrl.Card Temp	Ctrl.Card Temp	Slow Down
4	00000010	16	Ctrl. Word TO	Ctrl. Word TO	Catch Up
5	00000020	32	Over Current	Over Current	Feedback High
6	00000040	64	Torque Limit	Torque Limit	Feedback Low
7	00000080	128	Motor Th Over	Motor Th Over	Output Current High
8	00000100	256	Motor ETR Over	Motor ETR Over	Output Current Low
9	00000200	512	Inverter Overld.	Inverter Overld.	Output Freq High
10	00000400	1024	DC under Volt	DC under Volt	Output Freq Low
11	00000800	2048	DC over Volt	DC over Volt	Brake Check OK
12	00001000	4096	Short Circuit	DC Voltage Low	Braking Max
13	00002000	8192	Inrush Fault	DC Voltage High	Braking
14	00004000	16384	Mains ph. Loss	Mains ph. Loss	Out of Speed Range
15	00008000	32768	AMA Not OK	No Motor	OVC Active
16	00010000	65536	Live Zero Error	Live Zero Error	
17	00020000	131072	Internal Fault	10V Low	
18	00040000	262144	Brake Overload	Brake Overload	
19	00080000	524288	U phase Loss	Brake Resistor	
20	00100000	1048576	V phase Loss	Brake IGBT	
21	00200000	2097152	W phase Loss	Speed Limit	
22	00400000	4194304	Fieldbus Fault	Fieldbus Fault	
23	00800000	8388608	24 V Supply Low	24V Supply Low	
24	01000000	16777216	Mains Failure	Mains Failure	
25	02000000	33554432	1.8V Supply Low	Current Limit	
26	04000000	67108864	Brake Resistor	Low Temp	
27	08000000	134217728	Brake IGBT	Voltage Limit	
28	10000000	268435456	Option Change	Unused	
29	20000000	536870912	Drive Initialised	Unused	
30	40000000	1073741824	Safe Stop	Unused	

Table 9.2: Description of Alarm Word, Warning Word and Extended Status Word

The alarm words, warning words and extended status words can be read out via serial bus or optional fieldbus for diagnosis. See also par. 16-90, 16-92 and 16-94.

9.1.1. Warning/Alarm list

WARNING 1, 10 Volts low:

The 10 V voltage from terminal 50 on the control card is below 10 V. Remove some of the load from terminal 50, as the 10 V supply is overloaded. Max. 15 mA or minimum 590 ohm.

WARNING/ALARM 2, Live zero error:

The signal on terminal 53 or 54 is less than 50% of the value set in par. 6-10, par. 6-12, par. 6-20, or par. 6-22 respectively.

WARNING/ALARM 3, No motor:

No motor has been connected to the output of the frequency converter.

WARNING/ALARM 4, Mains phase loss:

A phase is missing on the supply side, or the mains voltage imbalance is too high.

This message also appears in case of a fault in the input rectifier on the frequency converter.

Check the supply voltage and supply currents to the frequency converter.

WARNING 5, DC link voltage high:

The intermediate circuit voltage (DC) is higher than the overvoltage limit of the control system. The frequency converter is still active.

WARNING 6, DC link voltage low

The intermediate circuit voltage (DC) is below the undervoltage limit of the control system. The frequency converter is still active.

WARNING/ALARM 7, DC over voltage:

If the intermediate circuit voltage exceeds the limit, the frequency converter trips after a time.

Connect a brake resistor. Extend the ramp time

Possible corrections:

Connect a brake resistor

Extend the ramp time

Activate functions in par. 2-10

Increase par. 14-26

Alarm/warning limits:			
Voltage ranges	3 x 200 - 240 V	3 x 380 - 480 V	3 x 525 - 600 V
	[VDC]	[VDC]	[VDC]
Undervoltage	185	373	532
Voltage warning low	205	410	585
Voltage warning high (w/o brake - w/ brake)	390/405	810/840	943/965
Overvoltage	410	855	975

The voltages stated are the intermediate circuit voltage of the frequency converter with a tolerance of ± 5 %. The corresponding mains voltage is the intermediate circuit voltage (DC-link) divided by 1.35

WARNING/ALARM 8, DC under voltage:

If the intermediate circuit voltage (DC) drops below the "voltage warning low" limit (see table above), the frequency converter checks if 24 V backup supply is connected.

If no 24 V backup supply is connected, the frequency converter trips after a given time depending on the unit.

To check whether the supply voltage matches the frequency converter, see *Specifications*.

WARNING/ALARM 9, Inverter overloaded:

The frequency converter is about to cut out because of an overload (too high current for too long). The counter for electronic, thermal inverter protection gives a warning at 98% and trips at 100%, while giving an alarm. Reset cannot be performed before counter is below 90%.

The fault is that the frequency converter is overloaded by more than 100% for too long.

WARNING/ALARM 10, Motor ETR over temperature:

According to the electronic thermal protection (ETR), the motor is too hot. It can be chosen if the frequency converter is to give a warning or an alarm when the counter reaches 100% in par. 1-90. The fault is that the motor is overloaded by more than 100% for too long. Check that the motor par. 1-24 is set correctly.

WARNING/ALARM 11, Motor thermistor over temp:

The thermistor or the thermistor connection is disconnected. Choose if the frequency converter is to give a warning or an alarm when the counter reaches 100% in par. 1-90. Check that the thermistor is connected correctly between terminal 53 or 54 (analog voltage input) and terminal 50 (+ 10 Volts supply), or between terminal 18 or 19 (digital input PNP only) and terminal 50. If a KTY sensor is used, check for correct connection between terminal 54 and 55.

WARNING/ALARM 12, Torque limit:

The torque is higher than the value in par. 4-16 (in motor operation) or the torque is higher than the value in par. 4-17 (in regenerative operation).

WARNING/ALARM 13, Over Current:

The inverter peak current limit (approx. 200% of the rated current) is exceeded. The warning will last approx. 8-12 sec., then the frequency converter trips and issues an alarm. Turn off the frequency converter and check if the motor shaft can be turned and if the motor size matches the frequency converter.

ALARM 14, Earth fault:

There is a discharge from the output phases to earth, either in the cable between the frequency converter and the motor or in the motor itself. Turn off the frequency converter and remove the earth fault.

ALARM 15, In-complete hardware:

A fitted option is not handled by the present control board (hardware or software).

ALARM 16, Short-circuit:

There is short-circuiting in the motor or on the motor terminals. Turn off the frequency converter and remove the short-circuit.

WARNING/ALARM 17, Control word timeout:

There is no communication to the frequency converter. The warning will only be active when par. 8-04 is NOT set to *OFF*. If par. 8-04 is set to *Stop* and *Trip*, a warning appears and the frequency converter ramps down until it trips, while giving an alarm. par. 8-03 *Control word Timeout Time* could possibly be increased.

WARNING 25, Brake resistor short-circuited:

The brake resistor is monitored during operation. If it short-circuits, the brake function is disconnected and the warning appears. The frequency converter still works, but without the brake function. Turn off the frequency converter and replace the brake resistor (see par. 2-15 *Brake Check*).

ALARM/WARNING 26, Brake resistor power limit:

The power transmitted to the brake resistor is calculated as a percentage, as a mean value over the last 120 s, on the basis of the resistance value of the brake resistor (par. 2-11) and the intermediate circuit voltage. The warning is active when the dissipated braking power is higher than 90%. If *Trip* [2] has been selected in par. 2-13, the frequency converter cuts out and issues this alarm, when the dissipated braking power is higher than 100%.

WARNING 27, Brake chopper fault:

The brake transistor is monitored during operation and if it short-circuits, the brake function disconnects and the warning comes up. The frequency converter is still able to run, but since the brake transistor has short-circuited, substantial power is transmitted to the brake resistor, even if it is inactive. Turn off the frequency converter and remove the brake resistor.



Warning: There is a risk of substantial power being transmitted to the brake resistor if the brake transistor is short-circuited.

ALARM/WARNING 28, Brake check failed:

Brake resistor fault: the brake resistor is not connected/working.

ALARM 29, Frequency converter over temperature:

If the enclosure is IP 20 or IP 21/TYP 1, the cut-out temperature of the heat-sink is 95 °C ±5 °C, dependent on size of frequency converter. The temperature fault cannot be reset, until the temperature of the heatsink is below 70 °C ±5 °C.

The fault could be:

- Ambient temperature too high
- Too long motor cable

ALARM 30, Motor phase U missing:

Motor phase U between the frequency converter and the the motor is missing.

Turn off the frequency converter and check motor phase U.

ALARM 31, Motor phase V missing:

Motor phase V between the frequency converter and the motor is missing.

Turn off the frequency converter and check motor phase V.

ALARM 32, Motor phase W missing:

Motor phase W between the frequency converter and the motor is missing.

Turn off the frequency converter and check motor phase W.

ALARM 33, Inrush fault:

Too many power-ups have occurred within a short time period. See the chapter *Specifications* for the allowed number of powerups within one minute.

WARNING/ALARM 34, Fieldbus communication fault:

The fieldbus on the communication option card is not working.

WARNING 35, Out of frequency range:

This warning is active if the output frequency has reached its *Warning speed low* (par. 4-52) or *Warning speed high* (par. 4-53). If the frequency converter is in *Process control, closed loop* (par. 1-00), the warning is active in the display. If the frequency converter is not in this mode bit 008000 *Out of frequency range* in extended status word is active but there is no warning in the display.

ALARM 38, Internal fault:

Contact the local supplier.

WARNING 47, 24 V supply low:

The external 24 V DC backup power supply may be overloaded, otherwise contact the local supplier.

WARNING 48, 1.8 V supply low:

Contact the local supplier.

ALARM 50, AMA calibration failed:

Contact the local supplier.

ALARM 51, AMA check Unom and Inom:

The setting of motor voltage, motor current, and motor power is presumably wrong. Check the settings.

ALARM 52, AMA low Inom:

The motor current is too low. Check the settings.

ALARM 53, AMA motor too big:

The motor is too big for the AMA to be carried out.

ALARM 54, AMA motor too small:

The motor is too small for the AMA to be carried out.

ALARM 55, AMA par. out of range:

The par. values found from the motor are outside acceptable range.

ALARM 56, AMA interrupted by user:

The AMA has been interrupted by the user.

ALARM 57, AMA timeout:

Try to start the AMA again a number of times, until the AMA is carried out. Please note that repeated runs may heat the motor to a level where the resistance R_s and R_r are increased. In most cases, however, this is not critical.

ALARM 58, AMA internal fault:

Contact the local supplier.

WARNING 59, Current limit:

Contact the local supplier.

WARNING 62, Output Frequency at Maximum Limit:

The output frequency is higher than the value set in par. 4-19

WARNING 64, Voltage Limit:

The load and speed combination demands a motor voltage higher than the actual DC link voltage.

WARNING/ALARM/TRIP 65, Control Card Over Temperature:

Control card over temperature: The cut-out temperature of the control card is 80° C.

WARNING 66, Heatsink Temperature Low:

The heat sink temperature is measured as 0° C. This could indicate that the temperature sensor is defective and thus the fan speed is increased to the maximum in case the power part or control card is very hot.

ALARM 67, Option Configuration has Changed:

One or more options has either been added or removed since the last power-down.

ALARM 68, Safe Stop Activated:

Safe Stop has been activated. To resume normal operation, apply 24 V DC to terminal 37, then send a reset signal (via Bus, Digital I/O, or by pressing [RESET]). For correct and safe use of the Safe Stop function follow the related information and instructions in the Design Guide

ALARM 70, Illegal Frequency Configuration:

Actual combination of control board and power board is illegal.

ALARM 80, Initialization to Default Value:

Parameter settings are initialised to default setting after a manual (three-finger) reset.

10

10. Specifications

10.1. General Specifications

10.1.1. Mains Supply 1 x 200 - 240 VAC

Mains Supply 1 x 200 - 240 VAC - Normal overload 110% for 1 minute

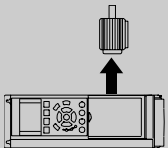
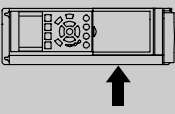
Frequency converter Typical Shaft Output [kW]	P5K 5	P7K 5	P15K	P22K
Typical Shaft Output [HP] at 240 V	7.5	10	20	30
IP 21 / NEMA 1	B1	B2	C1	C2
IP 55 / NEMA 12	B1	B2	C1	C2
IP 66 / NEMA 12	B1	B2	C1	C2
Output current				
	Continuous (1 x 200-240 V) [A]	30.8	59.4	88
	Intermittent (1 x 200-240 V) [A]	26.6	65.3	96.8
	Continuous kVA (208 V AC) [kVA]	5.00	6.40	12.27
	Max. cable size: (mains, motor, brake) [[mm ² / AWG] ²⁾	10/7	35/2	50/1/0
Max. input current				
	Continuous (1 x 200-240 V) [A]	46	111	172
	Intermittent (1 x 200-240 V) [A]	50.6	122.1	189.2
	Max. pre-fuses ¹⁾ [A]	80	100	150
	Environment			
	Estimated power loss at rated max. load [W] ⁴⁾	110	150	300
	Weight enclosure IP 21 [kg]	23	27	45
	Weight enclosure IP 55 [kg]	23	27	45
Weight enclosure IP 66 [kg]	23	27	45	
Efficiency ³⁾	0.98	0.98	0.98	0.98

Mains supply 3 x 200 - 240 VAC - Normal overload 110% for 1 minute												
IP 20 / NEMA Chassis (B3+4 and C3+4 may be converted to IP21 using a conversion kit (Please contact Danfoss))												
IP 21 / NEMA 1												
IP 55 / NEMA 12												
IP 66 / NEMA 12												
Frequency converter												
Typical Shaft Output [kW]												
Typical Shaft Output [HP] at 208 V												
	B3	B3	B3	B4	B4	B3	B3	B3	B4	B4	C3	C4
Continuous (3 x 200-240 V) [A]	24.2	30.8	46.2	59.4	74.8	88.0	115	143	170			
Intermittent (3 x 200-240 V) [A]	26.6	33.9	50.8	65.3	82.3	96.8	127	157	187			
Continuous kVA (208 V AC) [kVA]	8.7	11.1	16.6	21.4	26.9	31.7	41.4	51.5	61.2			
Max. cable size: (mains, motor, brake) [mm ² /AWG] ²⁾	10/7		35/2		50/1/0		95/4/0		120/250 MCM			
Max. input current												
Continuous (3 x 200-240 V) [A]	22.0	28.0	42.0	54.0	68.0	80.0	104.0	130.0	154.0			
Intermittent (3 x 200-240 V) [A]	24.2	30.8	46.2	59.4	74.8	88.0	114.0	143.0	169.0			
Max. pre-fuses ¹⁾ [A]	63	63	63	80	125	125	160	200	250			
Environment:												
Estimated power loss at rated max. load [W] ⁴⁾	269	310	447	602	737	845	1140	1353	1636			
Weight enclosure IP20 [kg]	12	12	12	23.5	23.5	35	35	50	50			
Weight enclosure IP21 [kg]	23	23	23	27	45	45	65	65	65			
Weight enclosure IP55 [kg]	23	23	23	27	45	45	65	65	65			
Weight enclosure IP 66 [kg]	23	23	23	27	45	45	65	65	65			
Efficiency ³⁾	0.96	0.96	0.96	0.96	0.96	0.97	0.97	0.97	0.97			

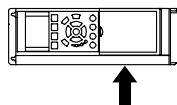
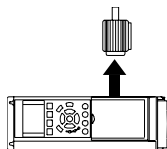

10.1.3. Mains Supply 3 x 380 - 480 VAC - Normal overload 110% for 1 minute

Mains Supply 3 x 380 - 480 VAC - Normal overload 110% for 1 minute

Frequency converter	PK37	PK55	PK75	PIK1	PIK5	P2K2	P3K0	P4K0	P5K5	P7K5
Typical Shaft Output [kW]	0.37	0.55	0.75	1.1	1.5	2.2	3	4	5.5	7.5
Typical Shaft Output [HP] at 460 V	0.5	0.75	1.0	1.5	2.0	2.9	4.0	5.3	7.5	10
IP 20 / NEMA Chassis	A2	A2	A2	A2	A2	A2	A2	A2	A3	A3
IP 21 / NEMA 1										
IP 55 / NEMA 12	A5	A5	A5	A5	A5	A5	A5	A5	A5	A5
IP 66 / NEMA 12	A5	A5	A5	A5	A5	A5	A5	A5	AA	A5
Output current										
Continuous (3 x 380-440 V) [A]	1.3	1.8	2.4	3	4.1	5.6	7.2	10	13	16
Intermittent (3 x 380-440 V) [A]	1.43	1.98	2.64	3.3	4.5	6.2	7.9	11	14.3	17.6
Continuous (3 x 441-480 V) [A]	1.2	1.6	2.1	2.7	3.4	4.8	6.3	8.2	11	14.5
Intermittent (3 x 441-480 V) [A]	1.32	1.76	2.31	3.0	3.7	5.3	6.9	9.0	12.1	15.4
Continuous kVA (400 V AC) [kVA]	0.9	1.3	1.7	2.1	2.8	3.9	5.0	6.9	9.0	11.0
Continuous kVA (460 V AC) [kVA]	0.9	1.3	1.7	2.4	2.7	3.8	5.0	6.5	8.8	11.6
Max. cable size: (mains, motor, brake) [mm ² /AWG] ²⁾	4/10									

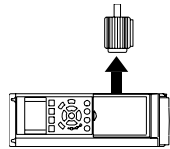

Max. input current

Continuous (3 x 380-440 V) [A]	1.2	1.6	2.2	2.7	3.7	5.0	6.5	9.0	11.7	14.4
Intermittent (3 x 380-440 V) [A]	1.32	1.76	2.42	3.0	4.1	5.5	7.2	9.9	12.9	15.8
Continuous (3 x 441-480 V) [A]	1.0	1.4	1.9	2.7	3.1	4.3	5.7	7.4	9.9	13.0
Intermittent (3 x 441-480 V) [A]	1.1	1.54	2.09	3.0	3.4	4.7	6.3	8.1	10.9	14.3
Max. pre-fuses ¹⁾ [A]	10	10	10	10	10	20	20	20	32	32
Environment										
Estimated power loss at rated max. load [W] ⁴⁾	35	42	46	58	62	88	116	124	187	255
Weight enclosure IP20 [kg]	4.7	4.7	4.8	4.8	4.9	4.9	4.9	4.9	6.6	6.6
Weight enclosure IP 21 [kg]	13.5	13.5	13.5	13.5	13.5	13.5	13.5	13.5	14.2	14.2
Weight enclosure IP 55 [kg]	13.5	13.5	13.5	13.5	13.5	13.5	13.5	13.5	14.2	14.2
Weight enclosure IP 66 [kg]	0.93	0.95	0.96	0.96	0.97	0.97	0.97	0.97	0.97	0.97
Efficiency ³⁾										

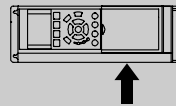

10

Mains Supply 3 x 380 - 480 VAC - Normal overload 110% for 1 minute

Frequency converter Typical Shaft Output [kW]	P11K 11	P15K 15	P18K 18.5	P22K 22	P30K 30	P37K 37	P45K 45	P55K 55	P75K 75	P90K 90	
Typical Shaft Output [HP] at 460 V	15	20	25	30	40	50	60	75	100	125	
IP 20 / NEMA Chassis (B3+4 and C3+4 may be converted to IP21 using a conversion kit (Please contact Danfoss))	B3	B3	B3	B4	B4	B4	C3	C3	C4	C4	
IP 21 / NEMA 1	B1	B1	B1	B2	B2	C1	C1	C1	C2	C2	
IP 55 / NEMA 12	B1	B1	B1	B2	B2	C1	C1	C1	C2	-	
IP 66 / NEMA 12	B1	B1	B1	B2	B2	C1	C1	C1	C2	-	
Output current											
Continuous (3 x 380-440 V) [A]	24	32	37.5	44	61	73	90	106	147	177	
Intermittent (3 x 380-440 V) [A]	26.4	35.2	41.3	48.4	67.1	80.3	99	117	162	195	
Continuous (3 x 441-480 V) [A]	21	27	34	40	52	65	80	105	130	160	
Intermittent (3 x 441-480 V) [A]	23.1	29.7	37.4	44	61.6	71.5	88	116	143	176	
Continuous kVA (400 V AC) [kVA]	16.6	22.2	26	30.5	42.3	50.6	62.4	73.4	102	123	
Continuous kVA (460 V AC) [kVA]	16.7	21.5	27.1	31.9	41.4	51.8	63.7	83.7	104	128	
Max. cable size: (mains, motor, brake) [[mm ² / AWG] ²⁾	10/7			35/2			50/1/0			120/4/0	

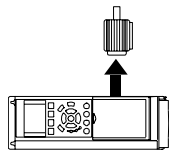

Max. input current

Continuous (3 x 380-440 V) [A]	22	29	34	40	55	66	82	96	133	161
Intermittent (3 x 380-440 V) [A]	24.2	31.9	37.4	44	60.5	72.6	90.2	106	146	177
Continuous (3 x 441-480 V) [A]	19	25	31	36	47	59	73	95	118	145
Intermittent (3 x 441-480 V) [A]	20.9	27.5	34.1	39.6	51.7	64.9	80.3	105	130	160
Max. pre-fuses ¹⁾ [A]	63	63	63	63	80	100	125	160	250	250
Environment										
Estimated power loss at rated max. load [W] ⁴⁾	278	392	465	525	739	698	843	1083	1384	1474
Weight enclosure IP20 [kg]	12	12	12	23.5	23.5	23.5	35	35	50	50
Weight enclosure IP 21 [kg]	23	23	23	27	27	45	45	45	65	65
Weight enclosure IP 55 [kg]	23	23	23	27	27	45	45	45	65	65
Weight enclosure IP 66 [kg]	23	23	23	27	27	45	45	45	-	-
Efficiency ³⁾	0.98	0.98	0.98	0.98	0.98	0.98	0.98	0.98	0.98	0.99

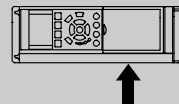

Normal overload 110% for 1 minute												
Frequency converter	P110	P132	P160	P200	P250	P315	P355	P400	P450			
Typical Shaft Output [kW]	110	132	160	200	250	315	355	400	450			
Typical Shaft Output [HP] at 460V	150	200	250	300	350	450	500	550	600			
IP 00	D3	D3	D4	D4	D4	E2	E2	E2	E2			
IP 21	D1	D1	D2	D2	D2	E1	E1	E1	E1			
IP 54	D1	D1	D2	D2	D2	E1	E1	E1	E1			
Output current												
	Continuous (3 x 400 V) [A]	212	260	315	395	480	600	745	800			
	Intermittent (3 x 400 V) [A]	233	286	347	435	528	660	820	880			
	Continuous (3 x 460-500V) [A]	190	240	302	361	443	540	590	678			
	Intermittent (3 x 460-500V) [A]	209	264	332	397	487	594	649	746			
	Continuous KVA (400 V AC) [kVA]	147	180	218	274	333	416	456	516			
	Continuous KVA (460 V AC) [kVA]	151	191	241	288	353	430	470	540			
Max. cable size:												
(mains, motor, brake) [mm ² / AWG] ²⁾	2x70	2x185		2x350 mcm		4x240		4x500 mcm				
Max. input current												
	Continuous (3 x 400 V) [A]	204	251	304	381	463	590	733	787			
	Continuous (3 x 460/500V) [A]	183	231	291	348	427	531	580	667			
	Max. pre-fuses ¹⁾ [A]	300	350	400	500	600	700	900	900			
	Environment											
Estimated power loss at rated max. load [W] ⁴⁾	3234	3782	4213	5119	5893	7630	7701	8879	9428			
Weight enclosure IP00 [kg]	81.9	90.5	111.8	122.9	137.7	221.4	234.1	236.4	277.3			
Weight enclosure IP 21 [kg]	95.5	104.1	125.4	136.3	151.3	263.2	270.0	272.3	313.2			
Weight enclosure IP 54 [kg]	95.5	104.1	125.4	136.3	151.3	263.2	270.0	272.3	313.2			
Efficiency ³⁾	0.98	0.98	0.98	0.98	0.98	0.98	0.98	0.98	0.98			

1) For type of fuse see section Fuses
 2) American Wire Gauge
 3) Measured using 5 m screened motor cables at rated load and rated frequency
 4) The typical power loss is at normal load conditions and expected to be within +/- 15% (tolerance relates to variety in voltage and cable conditions). Values are based on a typical motor efficiency (eff2/eff3 border line). Lower efficiency motors will also add to the power loss in the frequency converter and vice versa. If the switching frequency is raised from nominal the power losses may rise significantly. LCP and typical control card power consumptions are included. Further options and customer load may add up to 30W to the losses. (Though typically only 4W extra for a fully loaded control card, or options for slot A or slot B, each).
 Although measurements are made with state of the art equipment, some measurement inaccuracy must be allowed for (+/- 5%).

10

10.1.4. Mains Supply 3 x 525 - 600 VAC

Normal overload 110% for 1 minute		PK75	PK1K1	PK1K5	P2K2	P3K0	P3K7	P4K0	P5K5	P7K5	P11K	P15K	P18K	P22K	P30K	P37K	P45K	P55K	P75K	P90K
Size:		Typical Shaft Output [kW]																		
Output current		0.75	1.1	1.5	2.2	3	3.7	4	5.5	7.5	11	15	18.5	22	30	37	45	55	75	90
IP 20 / NEMA Chassis		A2	A2	A2	A2	A2	A2	A2	A3	A3	B3	B3	B3	B4	B4	B4	B4	C3	C3	C4
IP 21 / NEMA 1		A2	A2	A2	A2	A2	A2	A2	A3	A3	B1	B1	B1	B2	B2	B2	C1	C1	C2	C2
IP 55 / NEMA 12		A5	A5	A5	A5	A5	A5	A5	A5	A5	B1	B1	B1	B2	B2	B2	C1	C1	C2	C2
IP 66 / NEMA 12		A5	A5	A5	A5	A5	A5	A5	A5	A5	B1	B1	B1	B2	B2	B2	C1	C1	C2	C2
Continuous (3 x 525-550 V) [A]		1.8	2.6	2.9	4.1	5.2	-	6.4	9.5	11.5	19	23	28	36	43	54	65	87	105	137
Intermittent (3 x 525-550 V) [A]		2.9	3.2	3.2	4.5	5.7	-	7.0	10.5	12.7	21	25	31	40	47	59	72	96	116	151
Continuous (3 x 525-600 V) [A]		1.7	2.4	2.7	3.9	4.9	-	6.1	9.0	11.0	18	22	27	34	41	52	62	83	100	131
Intermittent (3 x 525-600 V) [A]		2.6	3.0	3.0	4.3	5.4	-	6.7	9.9	12.1	20	24	30	37	45	57	68	91	110	144
Continuous kVA (525 V AC) [kVA]		1.7	2.5	2.8	3.9	5.0	-	6.1	9.0	11.0	18.1	21.9	26.7	34.3	41	51.4	61.9	82.9	100	130.5
Continuous kVA (575 V AC) [kVA]		1.7	2.4	2.7	3.9	4.9	-	6.1	9.0	11.0	17.9	21.9	26.9	33.9	40.8	51.8	61.7	82.7	99.6	130.5
Max. cable size (mains, motor, brake) [AWG] ²⁾ [mm ²]		24 - 10 AWG 0.2 - 4																		
Max. input current		6 16																		
Continuous (3 x 525-600 V) [A]		1.7	2.4	2.7	4.1	5.2	-	5.8	8.6	10.4	17.2	20.9	25.4	32.7	39	49	59	78.9	95.3	124.3
Intermittent (3 x 525-600 V) [A]		2.7	3.0	3.0	4.5	5.7	-	6.4	9.5	11.5	19	23	28	36	43	54	65	87	105	137
Max. pre-fuses ¹⁾ [A]		10	10	10	20	20	-	20	32	32										
Environment:																				
Estimated power loss at rated max. load [W] ⁴⁾		35	50	65	92	122	-	145	195	261	225	285	329							
Enclosure IP 20:																				
Weight enclosure IP20 [kg]		6.5	6.5	6.5	6.5	6.5	-	6.5	6.6	6.6	12	12	12	23.5	23.5	23.5	35	35	50	50
Efficiency ⁴⁾		0.97	0.97	0.97	0.97	0.97	-	0.97	0.97	0.97	0.98	0.98	0.98	0.98	0.98	0.98	0.98	0.98	0.98	0.98

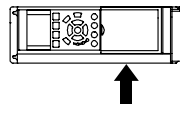
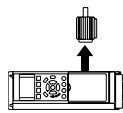

Table 10.1: ⁵⁾ Motor and mains cable: 300MCM/150mm²

Normal overload 110% for 1 minute													
Frequency converter	P110	P132	P160	P200	P250	P315	P355	P400	P500	P560			
Typical Shaft Output [kW]	110	132	160	200	250	315	355	400	500	560			
Typical Shaft Output [HP] at 575 V	150	200	250	300	350	400	450	500	600	650			
IP 00	D3	D3	D4	D4	D4	D4	E2	E2	E2	E2			
IP 21	D1	D1	D2	D2	D2	D2	E1	E1	E1	E1			
IP 54	D1	D1	D2	D2	D2	D2	E1	E1	E1	E1			
Output current													
	Continuous (3 x 550 V) [A]	162	201	253	303	418	470	523	596	630			
	Intermittent (3 x 550 V) [A]	178	221	278	333	460	517	575	656	693			
	Continuous (3 x 575-690 V) [A]	155	192	242	290	344	400	450	500	570			
	Intermittent (3 x 575-690 V) [A]	171	211	266	319	378	440	495	550	627			
	Continuous kVA (550 V AC) [kVA]	154	191	241	289	343	398	448	498	568			
	Continuous kVA (575 V AC) [kVA]	154	191	241	289	343	398	448	498	568			
Continuous kVA (690 V AC) [kVA]	185	229	289	347	411	478	538	598	681				
Max. cable size:													
(mains, motor, brake) [mm ² / AWG] ²⁾	2x70	2x185	2x350	2x350	2x350	2x350	2x350	2x350	2x350	2x350	2x350	2x350	
	2x2/0	4x240	4x500	4x500	4x500	4x500	4x500	4x500	4x500	4x500	4x500	4x500	
Max. input current													
	Continuous (3 x 550 V) [A]	158	198	245	299	408	453	504	574	607			
	Continuous (3 x 575 V) [A]	151	189	234	286	339	390	434	482	549			
	Continuous (3 x 690 V) [A]	155	197	240	296	352	400	434	482	549			
	Max. pre-fuses ¹⁾ [A]	225	250	350	400	500	600	700	700	900			
	Environment												
	Estimated power loss at rated max. load [W] ⁴⁾	3114	3612	4293	5156	5821	6149	6449	7249	8727	9673		
Weight enclosure IP00 [kg]	81.9	90.5	111.8	122.9	137.7	151.3	221	221	236	277			
Weight enclosure IP 21 [kg]	95.5	104.1	125.4	136.3	151.3	164.9	263	263	272	313			
Weight enclosure IP 54 [kg]	95.5	104.1	125.4	136.3	151.3	164.9	263	263	272	313			
Efficiency ³⁾	0.98	0.98	0.98	0.98	0.98	0.98	0.98	0.98	0.98	0.98			

¹⁾ For type of fuse see section *Fuses*
²⁾ American Wire Gauge
³⁾ Measured using 5 m screened motor cables at rated load and rated frequency
⁴⁾ The typical power loss is at normal load conditions and expected to be within +/- 15% (tolerance relates to variety in voltage and cable conditions). Values are based on a typical motor efficiency (eff2/eff3 border line). Lower efficiency motors will also add to the power loss in the frequency converter and vice versa. If the switching frequency is raised from nominal the power losses may rise significantly.
 LCP and typical control card power consumptions are included. Further options and customer load may add up to 30W to the losses. (Though typically only 4W extra for a fully loaded control card, or options for slot A or slot B, each).
 Although measurements are made with state of the art equipment, some measurement inaccuracy must be allowed for (+/- 5%).

Protection and Features:

- Electronic thermal motor protection against overload.
- Temperature monitoring of the heatsink ensures that the frequency converter trips if the temperature reaches $95\text{ °C} \pm 5\text{ °C}$. An overload temperature cannot be reset until the temperature of the heatsink is below $70\text{ °C} \pm 5\text{ °C}$ (Guideline - these temperatures may vary for different power sizes, enclosures etc.). The frequency converter has an auto derating function to avoid it's heatsink reaching 95 deg C.
- The frequency converter is protected against short-circuits on motor terminals U, V, W.
- If a mains phase is missing, the frequency converter trips or issues a warning (depending on the load).
- Monitoring of the intermediate circuit voltage ensures that the frequency converter trips if the intermediate circuit voltage is too low or too high.
- The frequency converter is protected against earth faults on motor terminals U, V, W.

Mains supply (L1, L2, L3):

Supply voltage	380-480 V $\pm 10\%$
Supply voltage	525-690 V $\pm 10\%$
Supply frequency	50/60 Hz
Max. imbalance temporary between mains phases	3.0 % of rated supply voltage
True Power Factor (λ)	≥ 0.9 nominal at rated load
Displacement Power Factor ($\cos\phi$) near unity	(> 0.98)
Switching on input supply L1, L2, L3 (power-ups) \leq enclosure type A	maximum 2 times/min.
Switching on input supply L1, L2, L3 (power-ups) \geq enclosure type B, C	maximum 1 time/min.
Environment according to EN60664-1	overvoltage category III/pollution degree 2

The unit is suitable for use on a circuit capable of delivering not more than 100.000 RMS symmetrical Amperes, 500/600/690 V maximum.

Motor output (U, V, W):

Output voltage	0 - 100% of supply voltage
Output frequency	0 - 1000 Hz
Switching on output	Unlimited
Ramp times	1 - 3600 sec.

Torque characteristics:

Starting torque (Constant torque)	maximum 110% for 1 min.*
Starting torque	maximum 135% up to 0.5 sec.*
Overload torque (Constant torque)	maximum 110% for 1 min.*

**Percentage relates to VLT AQUA Drive's nominal torque.*

Cable lengths and cross sections:

Max. motor cable length, screened/armoured	VLT AQUA Drive: 150 m
Max. motor cable length, unscreened/unarmoured	VLT AQUA Drive: 300 m
Max. cross section to motor, mains, load sharing and brake *	
Maximum cross section to control terminals, rigid wire	1.5 mm ² /16 AWG (2 x 0.75 mm ²)
Maximum cross section to control terminals, flexible cable	1 mm ² /18 AWG
Maximum cross section to control terminals, cable with enclosed core	0.5 mm ² /20 AWG
Minimum cross section to control terminals	0.25 mm ²

** See Mains Supply tables for more information!*

Control card, RS-485 serial communication:

Terminal number	68 (P,TX+, RX+), 69 (N,TX-, RX-)
Terminal number 61	Common for terminals 68 and 69

The RS-485 serial communication circuit is functionally separated from other central circuits and galvanically isolated from the supply voltage (PELV).

Digital inputs:

Programmable digital inputs	4 (6)
Terminal number	18, 19, 27 ¹⁾ , 29, 32, 33,
Logic	PNP or NPN
Voltage level	0 - 24 V DC
Voltage level, logic '0' PNP	< 5 V DC
Voltage level, logic '1' PNP	> 10 V DC
Voltage level, logic '0' NPN	> 19 V DC
Voltage level, logic '1' NPN	< 14 V DC
Maximum voltage on input	28 V DC
Input resistance, R _i	approx. 4 kΩ

All digital inputs are galvanically isolated from the supply voltage (PELV) and other high-voltage terminals.

1) Terminals 27 and 29 can also be programmed as output.

Digital output:

Programmable digital/pulse outputs	2
Terminal number	27, 29 ¹⁾
Voltage level at digital/frequency output	0 - 24 V
Max. output current (sink or source)	40 mA
Max. load at frequency output	1 kΩ
Max. capacitive load at frequency output	10 nF
Minimum output frequency at frequency output	0 Hz
Maximum output frequency at frequency output	32 kHz
Accuracy of frequency output	Max. error: 0.1 % of full scale
Resolution of frequency outputs	12 bit

1) Terminal 27 and 29 can also be programmed as input.

The digital output is galvanically isolated from the supply voltage (PELV) and other high-voltage terminals.

Analog inputs:

Number of analog inputs	2
Terminal number	53, 54
Modes	Voltage or current
Mode select	Switch S201 and switch S202
Voltage mode	Switch S201/switch S202 = OFF (U)
Voltage level	: 0 to + 10 V (scaleable)
Input resistance, R _i	approx. 10 kΩ
Max. voltage	± 20 V
Current mode	Switch S201/switch S202 = ON (I)
Current level	0/4 to 20 mA (scaleable)
Input resistance, R _i	approx. 200 Ω
Max. current	30 mA
Resolution for analog inputs	10 bit (+ sign)
Accuracy of analog inputs	Max. error 0.5% of full scale
Bandwidth	: 200 Hz

The analog inputs are galvanically isolated from the supply voltage (PELV) and other high-voltage terminals.

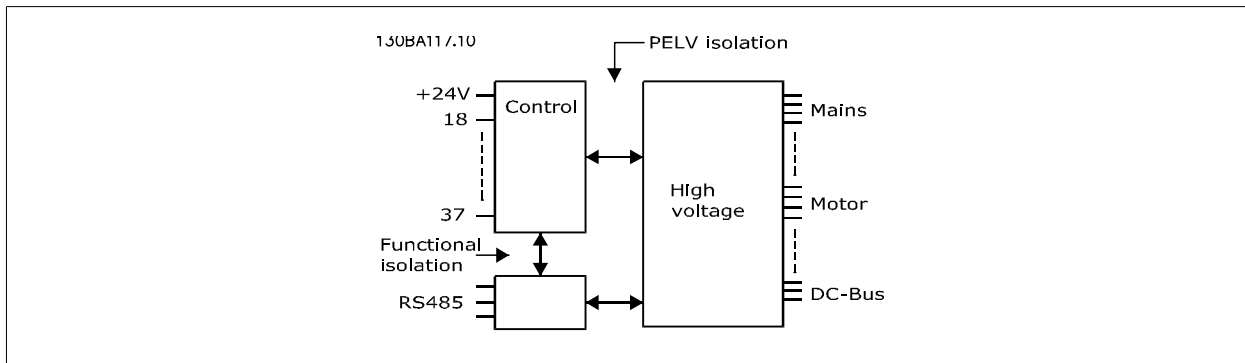

Analog output:

Number of programmable analog outputs	1
Terminal number	42
Current range at analog output	0/4 - 20 mA
Max. resistor load to common at analog output	500 Ω
Accuracy on analog output	Max. error: 0.8 % of full scale
Resolution on analog output	8 bit

The analog output is galvanically isolated from the supply voltage (PELV) and other high-voltage terminals.

Control card, 24 V DC output:

Terminal number	12, 13
Max. load	: 200 mA

The 24 V DC supply is galvanically isolated from the supply voltage (PELV), but has the same potential as the analog and digital inputs and outputs.

Relay outputs:

Programmable relay outputs	2
Relay 01 Terminal number	1-3 (break), 1-2 (make)
Max. terminal load (AC-1) ¹⁾ on 1-3 (NC), 1-2 (NO) (Resistive load)	240 V AC, 2 A
Max. terminal load (AC-15) ¹⁾ (Inductive load @ cosφ 0.4)	240 V AC, 0.2 A
Max. terminal load (DC-1) ¹⁾ on 1-2 (NO), 1-3 (NC) (Resistive load)	60 V DC, 1A
Max. terminal load (DC-13) ¹⁾ (Inductive load)	24 V DC, 0.1A
Relay 02 Terminal number	4-6 (break), 4-5 (make)
Max. terminal load (AC-1) ¹⁾ on 4-5 (NO) (Resistive load) ²⁾³⁾	400 V AC, 2 A
Max. terminal load (AC-15) ¹⁾ on 4-5 (NO) (Inductive load @ cosφ 0.4)	240 V AC, 0.2 A
Max. terminal load (DC-1) ¹⁾ on 4-5 (NO) (Resistive load)	80 V DC, 2 A
Max. terminal load (DC-13) ¹⁾ on 4-5 (NO) (Inductive load)	24 V DC, 0.1A
Max. terminal load (AC-1) ¹⁾ on 4-6 (NC) (Resistive load)	240 V AC, 2 A
Max. terminal load (AC-15) ¹⁾ on 4-6 (NC) (Inductive load @ cosφ 0.4)	240 V AC, 0.2A
Max. terminal load (DC-1) ¹⁾ on 4-6 (NC) (Resistive load)	50 V DC, 2 A
Max. terminal load (DC-13) ¹⁾ on 4-6 (NC) (Inductive load)	24 V DC, 0.1 A
Min. terminal load on 1-3 (NC), 1-2 (NO), 4-6 (NC), 4-5 (NO)	24 V DC 10 mA, 24 V AC 20 mA
Environment according to EN 60664-1	overvoltage category III/pollution degree 2

1) IEC 60947 part 4 and 5

The relay contacts are galvanically isolated from the rest of the circuit by reinforced isolation (PELV).

2) Overvoltage Category II

3) UL applications 300 V AC 2A

Control card, 10 V DC output:

Terminal number	50
Output voltage	10.5 V ±0.5 V
Max. load	25 mA

The 10 V DC supply is galvanically isolated from the supply voltage (PELV) and other high-voltage terminals.

Control characteristics:

Resolution of output frequency at 0 - 1000 Hz	: +/- 0.003 Hz
System response time (terminals 18, 19, 27, 29, 32, 33)	: ≤ 2 ms
Speed control range (open loop)	1:100 of synchronous speed
Speed accuracy (open loop)	30 - 4000 rpm: Maximum error of ±8 rpm

All control characteristics are based on a 4-pole asynchronous motor

Surroundings:

Enclosure type A	IP 20/Chassis, IP 21kit/Type 1, IP55/Type12, IP 66/Type12
Enclosure type B1/B2	IP 21/Type 1, IP55/Type12, IP 66/Type12
Enclosure type B3/B4	IP20/Chassis
Enclosure type C1/C2	IP 21/Type 1, IP55/Type 12, IP66/Type12
Enclosure type C3/C4	IP20/Chassis
Enclosure type D1/D2/E1	IP21/Type 1, IP54/Type12
Enclosure type D3/D4/E2	IP00/Chassis
Enclosure kit available ≤ enclosure type A	IP21/TYPE 1/IP 4X top
Vibration test	1.0 g
Max. relative humidity	5% - 95%(IEC 721-3-3; Class 3K3 (non-condensing) during operation
Aggressive environment (IEC 721-3-3), uncoated	class 3C2
Aggressive environment (IEC 721-3-3), coated	class 3C3
Test method according to IEC 60068-2-43 H2S (10 days)	
Ambient temperature	Max. 50 °C

Derating for high ambient temperature, see section on special conditions

Minimum ambient temperature during full-scale operation	0 °C
Minimum ambient temperature at reduced performance	- 10 °C
Temperature during storage/transport	-25 - +65/70 °C
Maximum altitude above sea level without derating	1000 m
Maximum altitude above sea level with derating	3000 m

Derating for high altitude, see section on special conditions

EMC standards, Emission	EN 61800-3, EN 61000-6-3/4, EN 55011, IEC 61800-3 EN 61800-3, EN 61000-6-1/2,
EMC standards, Immunity	EN 61000-4-2, EN 61000-4-3, EN 61000-4-4, EN 61000-4-5, EN 61000-4-6

See section on special conditions

Control card performance:

Scan interval	: 5 ms
---------------	--------

Control card, USB serial communication:

USB standard	1.1 (Full speed)
USB plug	USB type B "device" plug

Connection to PC is carried out via a standard host/device USB cable.
 The USB connection is galvanically isolated from the supply voltage (PELV) and other high-voltage terminals.
 The USB connection is not galvanically isolated from protection earth. Use only isolated laptop/PC as connection to the USB connector on VLT AQUA Drive or an isolated USB cable/converter.

10.1.5. Efficiency

Efficiency of the frequency converter (η_{VLT})

The load on the frequency converter has little effect on its efficiency. In general, the efficiency is the same at the rated motor frequency $f_{M,N}$, even if the motor supplies 100% of the rated shaft torque or only 75%, i.e. in case of part loads.

This also means that the efficiency of the frequency converter does not change even if other U/f characteristics are chosen. However, the U/f characteristics influence the efficiency of the motor.

The efficiency declines a little when the switching frequency is set to a value of above 5 kHz. The efficiency will also be slightly reduced if the mains voltage is 480 V, or if the motor cable is longer than 30 m.

Efficiency of the motor (η_{MOTOR})

The efficiency of a motor connected to the frequency converter depends on magnetising level. In general, the efficiency is just as good as with mains operation. The efficiency of the motor depends on the type of motor.

In the range of 75-100% of the rated torque, the efficiency of the motor is practically constant, both when it is controlled by the frequency converter and when it runs directly on mains.

In small motors, the influence from the U/f characteristic on efficiency is marginal. However, in motors from 11 kW and up, the advantages are significant.

In general, the switching frequency does not affect the efficiency of small motors. Motors from 11 kW and up have their efficiency improved (1-2%). This is because the sine shape of the motor current is almost perfect at high switching frequency.

Efficiency of the system (η_{SYSTEM})

To calculate the system efficiency, the efficiency of the frequency converter (η_{VLT}) is multiplied by the efficiency of the motor (η_{MOTOR}):

$$\eta_{SYSTEM} = \eta_{VLT} \times \eta_{MOTOR}$$

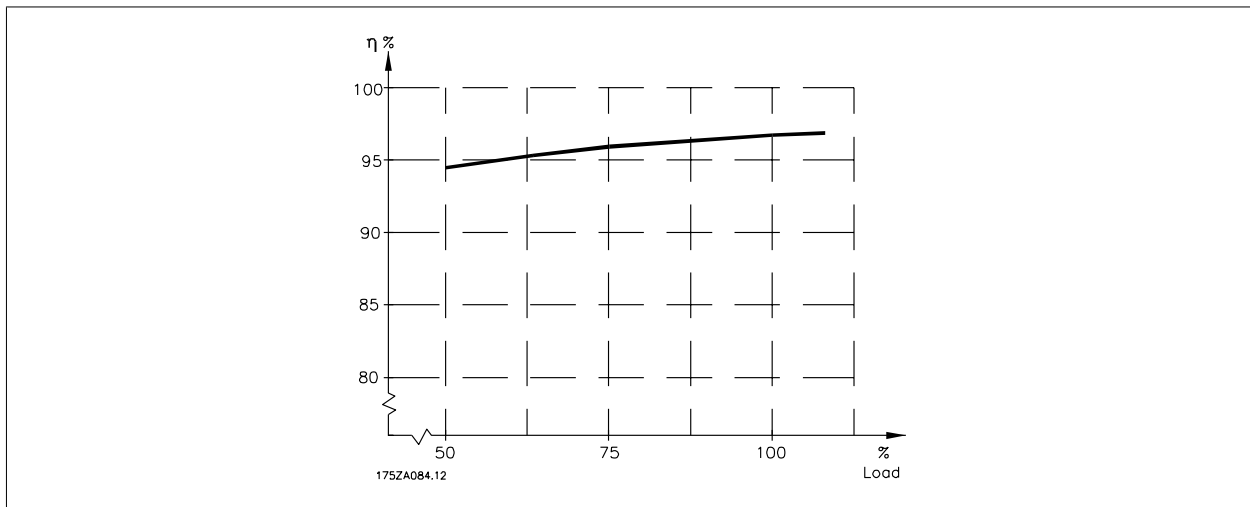

Based on the graph outlined above, it is possible to calculate the system efficiency at different speeds.

The acoustic noise from the frequency converter comes from three sources:

1. DC intermediate circuit coils.
2. Integral fan.
3. RFI filter choke.

The typical values measured at a distance of 1 m from the unit:

Enclosure	At reduced fan speed (50%) [dBA] ***	Full fan speed [dBA]
A2	51	60
A3	51	60
A5	54	63
B1	61	67
B2	58	70
B3	-	-
B4	-	-
C1	52	62
C2	55	65
C3	-	-
C4	-	-
D1+D3	74	76
D2+D4	73	74
E1/E2 *	73	74
E1/E2 **	82	83

* 315 kW, 380-480 VAC and 355 kW, 525-600 VAC only!
 ** Remaining E1+E2 power sizes.
 *** For D and E sizes, reduced fan speed is at 87%, measured at 200 V.

When a transistor in the inverter bridge switches, the voltage across the motor increases by a du/dt ratio depending on:

- the motor cable (type, cross-section, length screened or unscreened)
- inductance

The natural induction causes an overshoot U_{PEAK} in the motor voltage before it stabilises itself at a level depending on the voltage in the intermediate circuit. The rise time and the peak voltage U_{PEAK} affect the service life of the motor. If the peak voltage is too high, especially motors without phase coil insulation are affected. If the motor cable is short (a few metres), the rise time and peak voltage are lower.

If the motor cable is long (100 m), the rise time and peak voltage are higher.

In motors without phase insulation paper or other insulation reinforcement suitable for operation with voltage supply (such as a frequency converter), fit a du/dt filter or a sine-wave filter on the output of the frequency converter.

10.2. Special Conditions

10.2.1. Purpose of derating

Derating must be taken into account when using the frequency converter at low air pressure (heights), at low speeds, with long motor cables, cables with a large cross section or at high ambient temperature. The required action is described in this section.

10.2.2. Derating for Ambient Temperature

The average temperature ($T_{AMB, AVG}$) measured over 24 hours must be at least 5 °C lower than the maximum allowed ambient temperature ($T_{AMB, MAX}$).

If the frequency converter is operated at high ambient temperatures, the continuous output current should be decreased.

The derating depends on the switching pattern, which can be set to 60 AVM or SFAVM in parameter 14-00.

A enclosures

60 AVM - Pulse Width Modulation

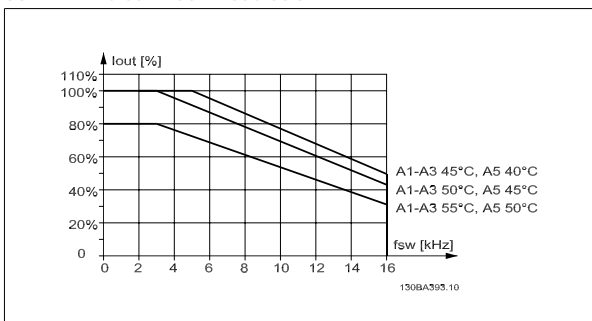

Illustration 10.1: Derating of I_{out} for different $T_{AMB, MAX}$ for enclosure A, using 60 AVM

SFAVM - Stator Frequency Asynchron Vector Modulation

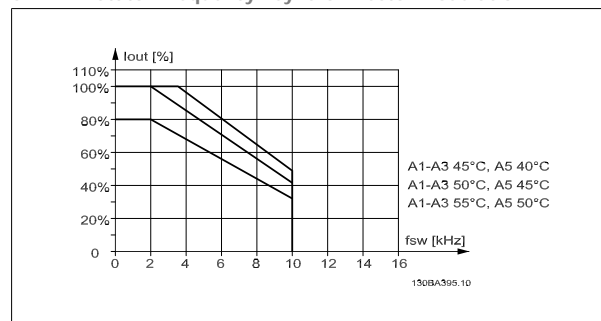

Illustration 10.2: Derating of I_{out} for different $T_{AMB, MAX}$ for enclosure A, using SFAVM

In enclosure A, the length of the motor cable has a relatively high impact on the recommended derating. Therefore, the recommended derating for an application with max. 10 m motor cable is also shown.

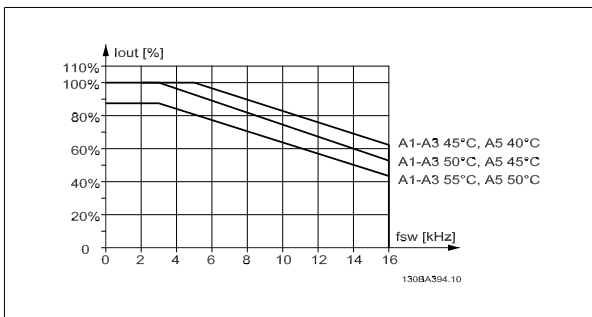

Illustration 10.3: Derating of I_{out} for different $T_{AMB, MAX}$ for enclosure A, using 60 AVM and maximum 10 m motor cable

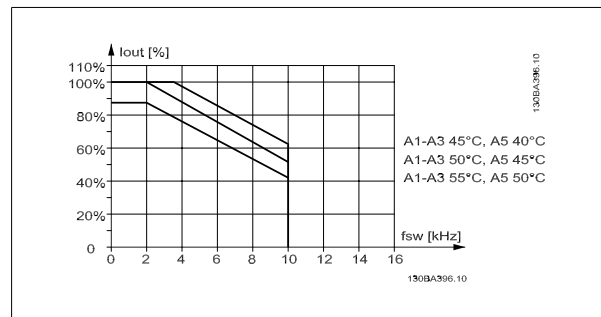

Illustration 10.4: Derating of I_{out} for different $T_{AMB, MAX}$ for enclosure A, using SFAVM and maximum 10 m motor cable

10

B enclosures

60 AVM - Pulse Width Modulation

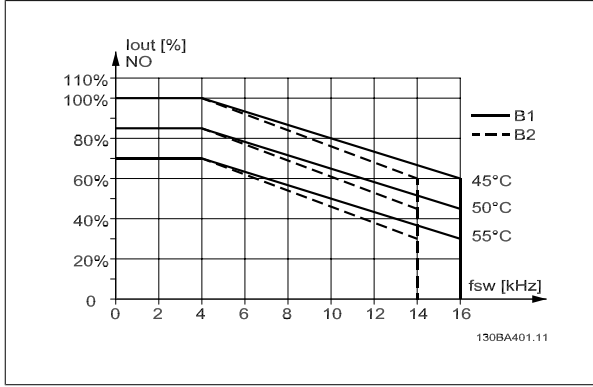

Illustration 10.5: Derating of I_{out} for different $T_{AMB, MAX}$ for enclosure B, using 60 AVM in Normal torque mode (110% over torque)

SFAVM - Stator Frequency Asyncon Vector Modulation

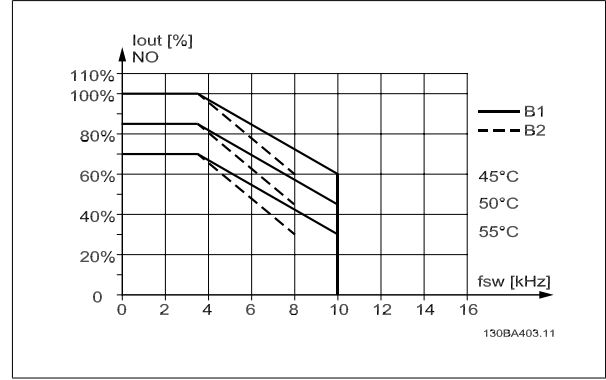

Illustration 10.6: Derating of I_{out} for different $T_{AMB, MAX}$ for enclosure B, using SFAVM in Normal torque mode (110% over torque)

C enclosures

Please note: For 90 kW in IP55 and IP66 the max. ambient temperature is 5° C lower.

60 AVM - Pulse Width Modulation

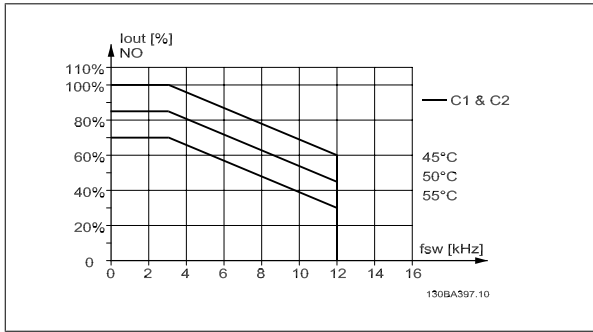

Illustration 10.7: Derating of I_{out} for different $T_{AMB, MAX}$ for enclosure C, using 60 AVM in Normal torque mode (110% over torque)

SFAVM - Stator Frequency Asyncon Vector Modulation

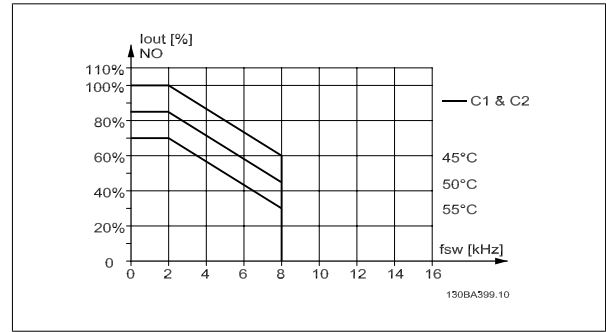

Illustration 10.8: Derating of I_{out} for different $T_{AMB, MAX}$ for enclosure C, using SFAVM in Normal torque mode (110% over torque)

D enclosures

60 AVM - Pulse Width Modulation, 380 - 480 V

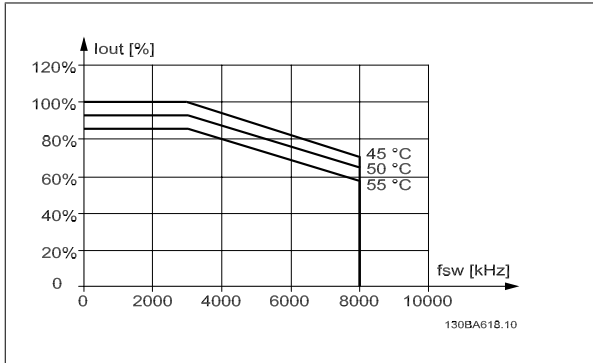

Illustration 10.9: Derating of I_{out} for different $T_{AMB, MAX}$ for enclosure D at 480 V, using 60 AVM in Normal torque mode (110% over torque)

SFAVM - Stator Frequency Asyncon Vector Modulation

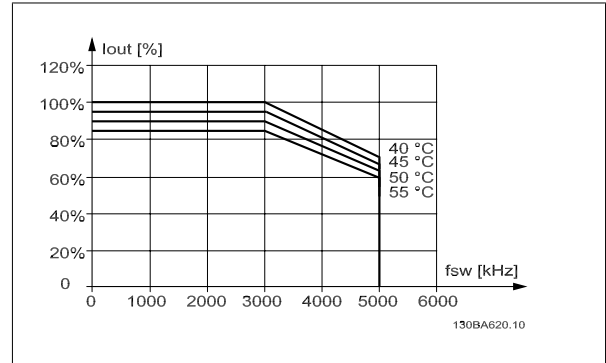

Illustration 10.10: Derating of I_{out} for different $T_{AMB, MAX}$ for enclosure D at 480 V, using SFAVM in Normal torque mode (110% over torque)

10

60 AVM - Pulse Width Modulation, 525 - 600 V (except P315)

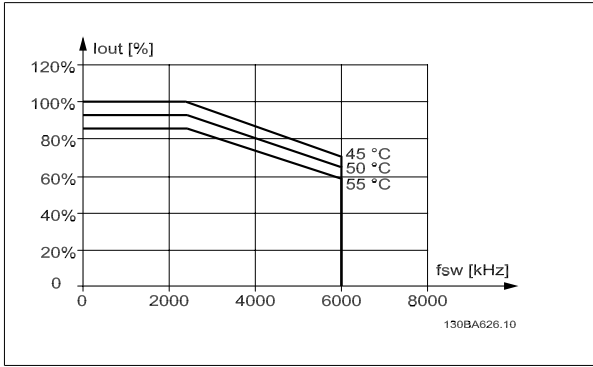

Illustration 10.11: Derating of I_{out} for different $T_{AMB, MAX}$ for enclosure D at 600 V, using 60 AVM in Normal torque mode (110% over torque).
Note: *not* valid for P315.

SFAVM - Stator Frequency Asyncon Vector Modulation

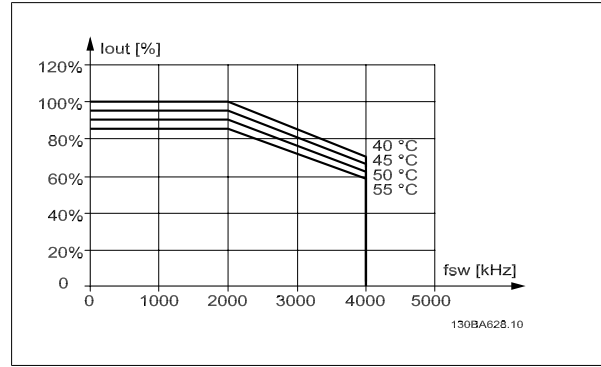

Illustration 10.12: Derating of I_{out} for different $T_{AMB, MAX}$ for enclosure D at 600 V, using SFAVM in Normal torque mode (110% over torque).
Note: *not* valid for P315.

60 AVM - Pulse Width Modulation, 525 - 600 V, P315

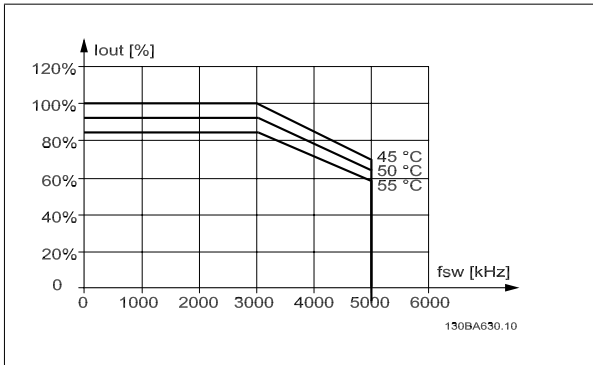

Illustration 10.13: Derating of I_{out} for different $T_{AMB, MAX}$ for enclosure D at 600 V, using 60 AVM in Normal torque mode (110% over torque).
Note: P315 *only*.

SFAVM - Stator Frequency Asyncon Vector Modulation

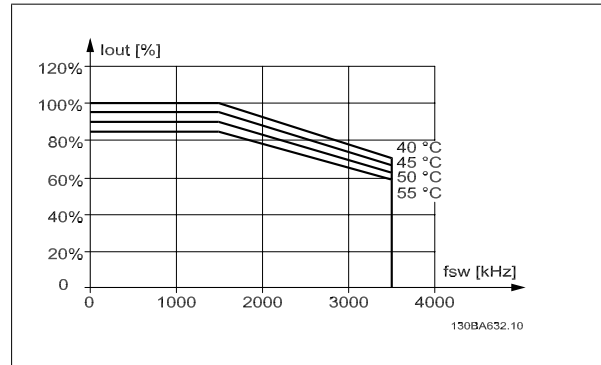

Illustration 10.14: Derating of I_{out} for different $T_{AMB, MAX}$ for enclosure D at 600 V, using SFAVM in Normal torque mode (110% over torque).
Note: P315 *only*.

E enclosures

60 AVM - Pulse Width Modulation, 380 - 480 V

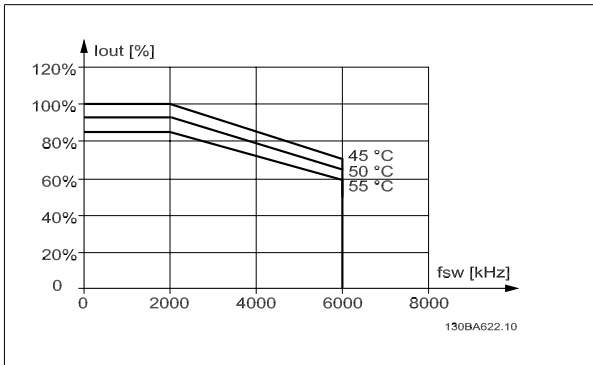

Illustration 10.15: Derating of I_{out} for different $T_{AMB, MAX}$ for enclosure E at 480 V, using 60 AVM in Normal torque mode (110% over torque)

SFAVM - Stator Frequency Asyncon Vector Modulation

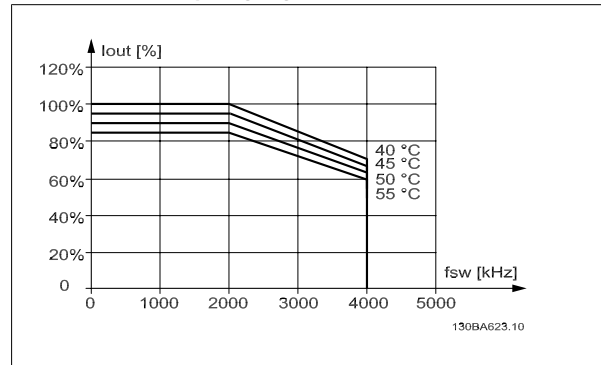

Illustration 10.16: Derating of I_{out} for different $T_{AMB, MAX}$ for enclosure E at 480 V, using SFAVM in Normal torque mode (110% over torque)

10

60 AVM - Pulse Width Modulation, 525 - 600 V

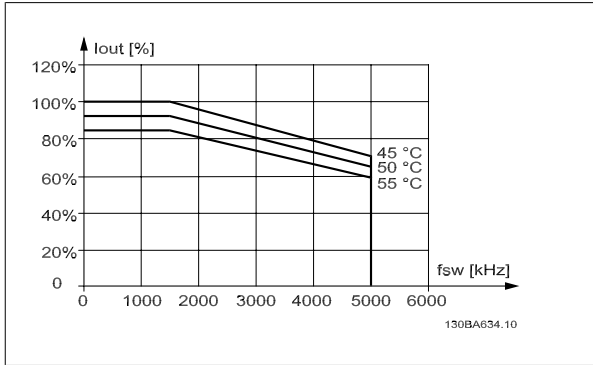

Illustration 10.17: Derating of I_{out} for different $T_{AMB, MAX}$ for enclosure E at 600 V, using 60 AVM in Normal torque mode (110% over torque).

SFAVM - Stator Frequency Asyncon Vector Modulation

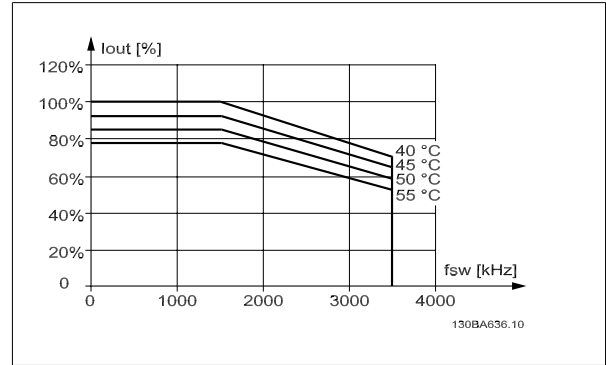

Illustration 10.18: Derating of I_{out} for different $T_{AMB, MAX}$ for enclosure E at 600 V, using SFAVM in Normal torque mode (110% over torque).

10.2.3. Derating for Low Air Pressure

The cooling capability of air is decreased at lower air pressure.

At altitudes higher than 2 km, please contact regarding PELV.

Below 1000 m altitude no derating is necessary but above 1000 m the ambient temperature (T_{AMB}) or max. output current (I_{out}) should be derated in accordance with the shown diagram.

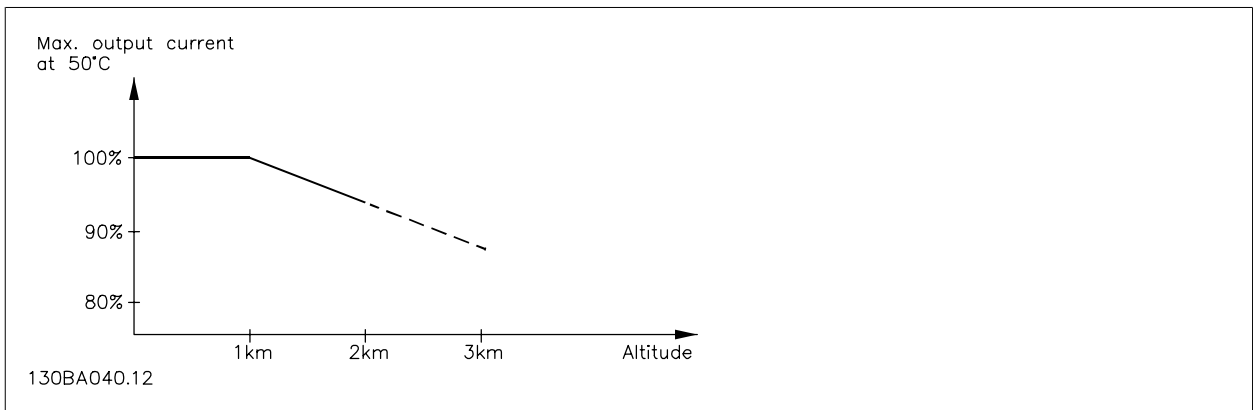

Illustration 10.19: Derating of output current versus altitude at $T_{AMB, MAX}$. By altitudes above 2 km, please contact regarding PELV.

An alternative is to lower the ambient temperature at high altitudes and thereby ensure 100% output current at high altitudes.

10.2.4. Derating for Running at Low Speed

When a motor is connected to a frequency converter, it is necessary to check that the cooling of the motor is adequate.

A problem may occur at low RPM values in constant torque applications. The motor fan may not be able to supply the required volume of air for cooling and this limits the torque that can be supported. Therefore, if the motor is to be run continuously at an RPM value lower than half of the rated value, the motor must be supplied with additional air-cooling (or a motor designed for this type of operation may be used).

An alternative is to reduce the load level of the motor by choosing a larger motor. However, the design of the frequency converter puts a limit to the motor size.

10.2.5. Derating for Installing Long Motor Cables or Cables with Larger Cross-Section

The maximum cable length for this frequency converter is 300 m unscreened and 150 m screened cable.

The frequency converter has been designed to work using a motor cable with a rated cross-section. If a cable with a larger cross-section is used, reduce the output current by 5% for every step the cross-section is increased.

(Increased cable cross-section leads to increased capacity to earth, and thus an increased earth leakage current).

10.2.6. Automatic adaptations to ensure performance

The frequency converter constantly checks for critical levels of internal temperature, load current, high voltage on the intermediate circuit and low motor speeds. As a response to a critical level, the frequency converter can adjust the switching frequency and / or change the switching pattern in order to ensure the performance of the frequency converter. The capability to automatically reduce the output current extends the acceptable operating conditions even further.

Index

6

60 Avm	150
--------	-----

A

Abbreviations And Standards	13
Acceleration Time	74
Access To Control Terminals	36
Acoustic Noise	148
Ama	57
Analog I/o Option Mcb 109	125
Analog In/out	107
Analog Inputs	145
Analog Output	146
Application Functions	120
Automatic Adaptations To Ensure Performance	154
Automatic Motor Adaptation (ama)	43, 72
Awg	137

B

Brakes	103
Bypass Option	128

C

Cable Lengths And Cross Sections	144
Can Fieldbus	110
Cascade Controller	123
Cascade Ctl Option	126
Changing A Group Of Numeric Data Values	56
Changing A Text Value	56
Changing Data	56
Changing Of Data Value	56
Check Valve Ramp End Speed [hz]	74
Check Valve Ramp End Speed [rpm]	74
Check Valve Ramp Time	74
Coasting	53
Comm. And Options	108
Communication Option	132
Configuration Mode, 1-00	71
Control Cables	40
Control Cables	40
Control Card Performance	147
Control Card, +10 V Dc Output	146
Control Card, 24 V Dc Output	146
Control Card, Rs-485 Serial Communication:	144
Control Card, Usb Serial Communication	147
Control Characteristics	147
Control Terminals	37
Cooling	153
Copyright, Limitation Of Liability And Revision Rights	3

D

Data Readouts	115
Data Readouts 2	117
Dc Link	131
Default Settings	58
Derating For Ambient Temperature	150
Derating For Installing Long Motor Cables Or Cables With Larger Cross-section	154
Derating For Low Air Pressure	153
Derating For Running At Low Speed	153
Digital In/out	106
Digital Inputs:	144
Digital Output	145

Display Line 1.2 Small, 0-21	70
Display Line 1.3 Small, 0-22	70
Display Line 2 Large, 0-23	70
Display Line 3 Large, 0-24	70
Display Text 2, 0-38	70
Display Text 3, 0-39	70
Disposal Instruction	9
Drive Closed Loop, 20-**	85
Dry Pump Function, 22-26	88
Dst/summertime Start, 0-76	71

E

Earthing And It Mains	26
Efficiency	148
Efficient Parameter Set-up For Water Applications	61
Electrical Installation	40
Electronic Waste	9
End Of Curve Delay	91
End Of Curve Function	91
End Of Curve Function, 22-50	91
Etr	132
Ext. Closed Loop	119

F

Fc Closed Loop	118
Fc Information	113
Filled Setpoint, 29-05	98
Final Ramp Time	75
Flow At Rated Speed, 22-90	94
Flow Compensation, 22-80	91
Frequency Converter	42
Function Relay, 5-40	79
Fuses	23

G

General Settings, 1-0*	71
General Warning	4
Glcp	57
Graphical Display	49

H

High Speed [hz], 22-37	89
High Speed Power [kw], 22-38	90
How To Connect A Pc To The Frequency Converter	59
How To Connect Motor - Foreword	31
How To Connect To Mains And Earthing For B1 And B2	30
How To Operate Graphical Lcp (glcp)	49
How To Read The Parameter Tables	99

I

Indexed Parameters	57
Indicator Lights (leds):	51
Initial Ramp Time	74
Initialisation	58
Installation At High Altitudes	5
Intermediate Circuit	131, 148, 149

K

Kty Sensor	132
------------	-----

L

Language	67
Lcp	54, 57

Lcp 102	49
Leakage Current	6
Leds	49
Limits / Warnings	105
Live Zero Timeout Function, 6-01	81
Live Zero Timeout Time, 6-00	81
Load/motor	102
Low Power Detection, 22-21	88
Low Speed Detection, 22-22	88

M

Main Menu	61
Main Menu Mode	52
Main Menu Mode	66
Main Reactance	73
Mains Connection For A2 And A3	27
Mains Connection For B1, B2 And B3	30
Mains Connection For C1 And C2	31
Mains Supply	137, 142
Mains Supply (I1, L2, L3)	144
Maximum Boost Time	91
Maximum Reference, 3-03	73
Mct 10	60
Mechanical Dimensions	20, 22
Minimum Run Time, 22-40	90
Minimum Sleep Time, 22-41	90
Motor Current	72
Motor Frequency, 1-23	72
Motor Name Plate	42
Motor Nominal Speed, 1-25	72
Motor Output	144
Motor Power [kw], 1-20	72
Motor Protection	144
Motor Speed High Limit [rpm], 4-13	75
Motor Speed Low Limit Rpm, 4-11	75
Motor Voltage	149
Motor Voltage	72
Motor Voltage, 1-22	72

N

Name Plate Data	42
Name Plate Data.	42
Nlcp	54
No-flow Delay, 22-24	88
No-flow Function, 22-23	88
Non UI Compliance	23

O

Occurrence, 23-04	97
Off Action, 23-03	96
On Action, 23-01	94
Operation/display	100
Output Performance (u, V, W)	144

P

Parameter Options	99
Parameter Selection	66
Parameter Set-up	61
Pc Software Tools	60
Peak Voltage On Motor	149
Pid Integral Time, 20-94	87
Pid Normal/inverse Control, 20-81	87
Pid Proportional Gain, 20-93	87
Pid Start Speed [rpm], 20-82	87
Pipe Fill Rate, 29-04	98

Pipe Fill Speed [hz], 29-02	98
Pipe Fill Speed [rpm], 29-01	98
Pipe Fill Time, 29-03	98
Preset Reference	73
Pressure At No-flow Speed, 22-87	93
Pressure At Rated Speed, 22-88	93
Profibus	109
Profibus Dp-v1	60
Protection	23
Protection And Features	144
Pulse Width Modulation	150

Q

Q1 My Personal Menu	62
Q2 Quick Setup	62
Q3 Function Setups	63
Q5 Changes Made	65
Q6 Loggings	65
Quick Menu	52, 61
Quick Menu Mode	52
Quick Transfer Of Parameter Settings When Using Glcp	57

R

Ramp 1 Ramp-down Time, 3-42	74
Ramp-up Time 1 Parameter, 3-41	74
Reference / Ramps	104
Reference/feedback Unit, 20-12	85
Relay Outputs	146
Reset	53
Residual Current Device	6
Rise Time	149
Rs-485 Bus Connection	58

S

Safety Note	5
Screened/armoured.	40
Serial Communication	147
Set Date And Time, 0-70	71
Setpoint 1, 20-21	86
Sfavm	150
Sine-wave Filter	32
Smart Logic	111
Special Functions	112
Speed At Design Point [hz], 22-86	93
Speed At Design Point [rpm], 22-85	93
Speed At No-flow [hz], 22-84	93
Speed At No-flow [rpm], 22-83	93
Square-linear Curve Approximation, 22-81	91
Start/stop	45
Stator Frequency Asynchron Vector Modulation	150
Stator Leakage Reactance	73
Status	52
Status Messages	49
Step-by-step	56
Submersible Pump	46
Surroundings	147
Switches S201, S202, And S801	41

T

Terminal 32 Digital Input, 5-14	79
Terminal 33 Digital Input, 5-15	79
Terminal 42 Output Max Scale 6-52	84
Terminal 42 Output Min Scale, 6-51	84
Terminal 42 Output, 6-50	83
Terminal 53 High Voltage, 6-11	82

Terminal 53 Low Voltage, 6-10	82
Timed Actions	122
Timed Actions, 23-0*	94
Torque Characteristics	144
Type Code String	12
Type Code String (t/c)	11

U

Usb Connection	37
----------------	----

V

Voltage Level	145
---------------	-----

W

Wake-up Ref./fb Difference	90
Wake-up Speed [rpm], 22-42	90
Warning Against Unintended Start	5
Water Application Functions	127
Wiring Example And Testing	35
Work Point Calculation, 22-82	92