

## Contents

<b>1 How to Read these Operating Instructions</b>	<b>3</b>
Copyright, Limitation of Liability and Revision Rights	4
Approvals	4
Symbols	5
<b>2 Safety</b>	<b>7</b>
General Warning	8
Before commencing repair work	8
Special conditions	8
Avoid unintended start	9
Safe Stop of the Frequency Converter (optional)	9
IT mains	10
<b>3 Introduction</b>	<b>11</b>
Type Code String	11
<b>4 Mechanical installation</b>	<b>13</b>
Before starting	13
<b>5 Electrical installation</b>	<b>19</b>
How to connect	19
Mains wiring overview	25
Motor wiring overview	32
DC bus connection	36
Brake Connection Option	37
Relay Connection	38
Electrical Installation and Control Cables	44
How to Test Motor and Direction of Rotation.	45
<b>6 Application Examples</b>	<b>51</b>
Closed Loop Wiring	51
Submersible Pump Application	52
<b>7 How to operate the frequency converter</b>	<b>55</b>
Ways of Operation	55
How to operate graphical LCP (GLCP)	55
How to operate numeric LCP (NLCP)	59
Tips and tricks	62
<b>8 How to programme the frequency converter</b>	<b>67</b>
How to programme	67
Q1 My Personal Menu	68

Q2 Quick Setup	68
Q5 Changes Made	70
Q6 Loggings	71
Commonly Used Parameters - Explanations	72
Main Menu	72
Parameter Options	110
Default settings	110
Operation/Display 0-**	111
Load/Motor 1-**	113
Brakes 2-**	115
Reference / Ramps 3-**	116
Limits / Warnings 4-**	117
Digital In/Out 5-**	118
Analog In/Out 6-**	119
Comm. and Options 8-**	120
Profibus 9-**	121
CAN Fieldbus 10-**	122
Smart Logic 13-**	123
Special Functions 14-**	124
FC Information 15-**	125
Data Readouts 16-**	127
Data Readouts 2 18-**	129
FC Closed Loop 20-**	130
Ext. Closed Loop 21-**	131
Application Functions 22-**	133
Timed Actions 23-**	135
Cascade Controller 25-**	136
Analog I/O Option MCB 109 26-**	138
Cascade CTL Option 27-**	139
Water Application Functions 29-**	141
Bypass Option 31-**	142
<b>9 Troubleshooting</b>	<b>143</b>
Fault messages	146
<b>10 Specifications</b>	<b>149</b>
General Specifications	149
Efficiency	164
Special Conditions	170
<b>Index</b>	<b>176</b>

## 1 How to Read these Operating Instructions

1

# VLT AQUA Drive FC 200 Series Software version: 1.33



This guide can be used with all FC 200 frequency converters with software version 1.33 or later.  
The actual software version number can be read from par. 15-43 *Software Version*.

**1****1.1.1 Copyright, Limitation of Liability and Revision Rights**

This publication contains information proprietary to Danfoss. By accepting and using this manual the user agrees that the information contained herein will be used solely for operating equipment from Danfoss or equipment from other vendors provided that such equipment is intended for communication with Danfoss equipment over a serial communication link. This publication is protected under the Copyright laws of Denmark and most other countries.

Danfoss does not warrant that a software program produced according to the guidelines provided in this manual will function properly in every physical, hardware or software environment.

Although Danfoss has tested and reviewed the documentation within this manual, Danfoss makes no warranty or representation, neither expressed nor implied, with respect to this documentation, including its quality, performance, or fitness for a particular purpose.

In no event shall Danfoss be liable for direct, indirect, special, incidental, or consequential damages arising out of the use, or the inability to use information contained in this manual, even if advised of the possibility of such damages. In particular, Danfoss is not responsible for any costs, including but not limited to those incurred as a result of lost profits or revenue, loss or damage of equipment, loss of computer programs, loss of data, the costs to substitute these, or any claims by third parties.

Danfoss reserves the right to revise this publication at any time and to make changes to its contents without prior notice or any obligation to notify former or present users of such revisions or changes.

**1.1.2 Available Literature for VLT® AQUA DriveFC 200**

- VLT® AQUA Drive Operating Instructions MG.20.Mx.yy provide the necessary information for getting the drive up and running.
- VLT® AQUA Drive High Power Operating Instructions MG.20.Px.yy provide the necessary information for getting the HP drive up and running.
- VLT® AQUA Drive Design Guide MG.20.Nx.yy entails all technical information about the drive and customer design and applications.
- VLT® AQUA Drive Programming Guide MN.20.Ox.yy provides information on how to programme and includes complete parameter descriptions.
- VLT® AQUA Drive FC 200 Profibus MG.33.Cx.yy
- VLT® AQUA Drive FC 200 DeviceNet MG.33.Dx.yy
- Output Filters Design Guide MG.90.Nx.yy
- VLT® AQUA Drive FC 200 Cascade Controller MI.38.Cx.yy
- Application Note MN20A102: Submersible Pump Application
- Application Note MN20B102: Master/Follower Operation Application
- Application Note MN20F102: Drive Closed Loop and Sleep Mode
- Instruction MI.38.Bx.yy: Installation Instruction for Mounting Brackets Enclosure type A5, B1, B2, C1 and C2 IP21, IP55 or IP66
- Instruction MI.90.Lx.yy: Analog I/O Option MCB109
- Instruction MI.33.Hx.yy: Panel through mount kit

x = Revision number

yy = Language code

Danfoss technical literature is also available online at

[www.danfoss.com/BusinessAreas/DrivesSolutions/Documentations/Technical+Documentation.htm](http://www.danfoss.com/BusinessAreas/DrivesSolutions/Documentations/Technical+Documentation.htm).

**1.1.3 Approvals**

### 1.1.4 Symbols

Symbols used in these Operating Instructions.

	<b>NB!</b> Indicates something to be noted by the reader.
---	--

	Indicates a general warning.
---	------------------------------

	Indicates a high-voltage warning.
---	-----------------------------------

*	Indicates default setting
---	---------------------------

**2**

## 2 Safety

2

### 2.1.1 Safety note



The voltage of the frequency converter is dangerous whenever connected to mains. Incorrect installation of the motor, frequency converter or fieldbus may cause damage to the equipment, serious personal injury or death. Consequently, the instructions in this manual, as well as national and local rules and safety regulations, must be complied with.

#### Safety Regulations

1. The frequency converter must be disconnected from mains if repair work is to be carried out. Check that the mains supply has been disconnected and that the necessary time has passed before removing motor and mains plugs.
2. The [STOP/RESET] key on the control panel of the frequency converter does not disconnect the equipment from mains and is thus not to be used as a safety switch.
3. Correct protective earthing of the equipment must be established, the user must be protected against supply voltage, and the motor must be protected against overload in accordance with applicable national and local regulations.
4. The earth leakage currents are higher than 3.5 mA.
5. Protection against motor overload is set by par. 1-90 *Motor Thermal Protection*. If this function is desired, set par. 1-90 to data value [ETR trip] (default value) or data value [ETR warning]. Note: The function is initialised at 1.16 x rated motor current and rated motor frequency. For the North American market: The ETR functions provide class 20 motor overload protection in accordance with NEC.
6. Do not remove the plugs for the motor and mains supply while the frequency converter is connected to mains. Check that the mains supply has been disconnected and that the necessary time has passed before removing motor and mains plugs.
7. Please note that the frequency converter has voltage inputs other than L1, L2 and L3, when load sharing (linking of DC intermediate circuit) and external 24 V DC have been installed. Check that all voltage inputs have been disconnected and that the necessary time has passed before commencing repair work.

#### Installation at High Altitudes



##### Installation at high altitude:

380 - 480 V: At altitudes above 3 km, please contact Danfoss Drives regarding PELV.  
525 - 690 V: At altitudes above 2 km, please contact Danfoss Drives regarding PELV.

#### Warning against Unintended Start

1. The motor can be brought to a stop by means of digital commands, bus commands, references or a local stop, while the frequency converter is connected to mains. If personal safety considerations make it necessary to ensure that no unintended start occurs, these stop functions are not sufficient.
2. While parameters are being changed, the motor may start. Consequently, the stop key [STOP/RESET] must always be activated; following which data can be modified.
3. A motor that has been stopped may start if faults occur in the electronics of the frequency converter, or if a temporary overload or a fault in the supply mains or the motor connection ceases.



##### Warning:

Touching the electrical parts may be fatal - even after the equipment has been disconnected from mains.

Also make sure that other voltage inputs have been disconnected, such as external 24 V DC, load sharing (linkage of DC intermediate circuit), as well as the motor connection for kinetic back up.

### 2.1.2 General Warning



**Warning:**

Touching the electrical parts may be fatal - even after the equipment has been disconnected from mains.

Also make sure that other voltage inputs have been disconnected, (linkage of DC intermediate circuit), as well as the motor connection for kinetic back-up.

Before touching any potentially live parts of the VLT AQUA Drive FC 200, wait at least as follows:

200 - 240 V, 0.25 - 3.7 kW: wait at least 4 minutes.

200 - 240 V, 5.5 - 45 kW: wait at least 15 minutes.

380 - 480 V, 0.37 - 7.5 kW: wait at least 4 minutes.

380 - 480 V, 11 - 90 kW, wait at least 15 minutes.

525 - 600 V, 1.1 - 7.5 kW, wait at least 4 minutes.

525 - 600 V, 110 - 250 kW, wait at least 20 minutes.

525 - 600 V, 315 - 560 kW, wait at least 30 minutes.

Shorter time is allowed only if indicated on the nameplate for the specific unit.



**Leakage Current**

The earth leakage current from the VLT AQUA Drive FC 200 exceeds 3.5 mA. According to IEC 61800-5-1 a reinforced Protective Earth connection must be ensured by means of: a min. 10mm<sup>2</sup> Cu or 16mm<sup>2</sup> Al PE-wire or an additional PE wire - with the same cable cross section as the Mains wiring - must be terminated separately.

**Residual Current Device**

This product can cause a D.C. current in the protective conductor. Where a residual current device (RCD) is used for extra protection, only an RCD of Type B (time delayed) shall be used on the supply side of this product. See also RCD Application Note MN.90.GX.02.

Protective earthing of the VLT AQUA Drive FC 200 and the use of RCD's must always follow national and local regulations.

### 2.1.3 Before commencing repair work

1. Disconnect the frequency converter from mains
2. Disconnect DC bus terminals 88 and 89
3. Wait at least the time mentioned in section General Warning above
4. Remove motor cable

### 2.1.4 Special conditions

**Electrical ratings:**

The rating indicated on the nameplate of the frequency converter is based on a typical 3-phase mains power supply, within the specified voltage, current and temperature range, which is expected to be used in most applications.

**The frequency converters also support other special applications, which affect the electrical ratings of the frequency converter. Special conditions which affect the electrical ratings might be:**

- Single phase applications
- High temperature applications which require derating of the electrical ratings
- Marine applications with more severe environmental conditions.

Consult the relevant clauses in these instructions and in the **VLT® AQUA Drive Design Guide** for information about the electrical ratings.

**Installation requirements:**

**The overall electrical safety of the frequency converter requires special installation considerations regarding:**

- Fuses and circuit breakers for over-current and short-circuit protection
- Selection of power cables (mains, motor, brake, loadsharing and relay)
- Grid configuration (IT, TN, grounded leg, etc.)
- Safety of low-voltage ports (PELV conditions).

Consult the relevant clauses in these instructions and in the **VLT® AQUA Drive Design Guide** for information about the installation requirements.



### 2.1.5 Caution

The frequency converter DC link capacitors remain charged after power has been disconnected. To avoid an electrical shock hazard, disconnect the frequency converter from the mains before carrying out maintenance. Wait at least as follows before doing service on the frequency converter:



Voltage (V)	Min. Waiting Time (Minutes)				
	4	15	20	30	40
200 - 240	0.25 - 3.7 kW	5.5 - 45 kW			
380 - 480	0.37 - 7.5 kW	11 - 90 kW	110 - 250 kW	315 - 1000 kW	
525-600	0.75 kW - 7.5 kW	11 - 90 kW			315 - 1200 kW
525-690		11 - 90 kW	45 - 400 kW	450 - 1200 kW	

Be aware that there may be high voltage on the DC link even when the LEDs are turned off.

### 2.1.6 Avoid unintended start

**While the frequency converter is connected to mains, the motor can be started/stopped using digital commands, bus commands, references or via the Local Control Panel.**

- Disconnect the frequency converter from mains whenever personal safety considerations make it necessary to avoid unintended start.
- To avoid unintended start, always activate the [OFF] key before changing parameters.
- Unless terminal 37 is turned off, an electronic fault, temporary overload, a fault in the mains supply, or lost motor connection may cause a stopped motor to start.

### 2.1.7 Safe Stop of the Frequency Converter (optional)

For versions fitted with a Safe Stop terminal 37 input, the frequency converter can perform the safety function *Safe Torque Off* (As defined by draft CD IEC 61800-5-2) or *Stop Category 0* (as defined in EN 60204-1).

It is designed and approved suitable for the requirements of Safety Category 3 in EN 954-1. This functionality is called Safe Stop. Prior to integration and use of Safe Stop in an installation, a thorough risk analysis on the installation must be carried out in order to determine whether the Safe Stop functionality and safety category are appropriate and sufficient. In order to install and use the Safe Stop function in accordance with the requirements of Safety Category 3 in EN 954-1, the related information and instructions of the VLT AQUA Drive Design Guide MG.20.NX.YY must be followed! The information and instructions of the Operating Instructions are not sufficient for a correct and safe use of the Safe Stop functionality!

2

Prof.- und Zertifizierungsstelle im BG-PRÜFZERT		<b>BGIA</b> Berufsgenossenschaftliches Institut für Arbeitsschutz Hauptverband der gewerblichen Berufsgenossenschaften		130BA373.10
Translation <small>In any case, the German original shall prevail.</small>		<b>Type Test Certificate</b>		
Name and address of the holder of the certificate (customer): Danfoss Drives A/S, Ulnoes 1 DK-6300 Graasten, Dänemark		No. of certificate 05 06004		
Name and address of the manufacturer: Danfoss Drives A/S, Ulnoes 1 DK-6300 Graasten, Dänemark				
Ref. of customer:	Ref. of Test and Certification Body: Apf/Ksh VE-Nr. 2003 23220	Date of issue: 13.04.2005		
Product designation: Frequency converter with integrated safety functions				
Type: VLT® Automation Drive FC 302				
Intended purpose: Implementation of safety function „Safe Stop“				
Testing based on: EN 954-1, 1997-03, DKE AK 226.03, 1998-06, EN ISO 13849-2:2003-12, EN 61800-3, 2001-02, EN 61800-5-1, 2003-09,				
Test certificate: No.: 2003 23220 from 13.04.2005				
Remarks: The presented types of the frequency converter FC 302 meet the requirements laid down in the test bases. With correct wiring a category 3 according to DIN EN 954-1 is reached for the safety function.				
The type tested complies with the provisions laid down in the directive 98/37/EC (Machinery).				
Further conditions are laid down in the Rules of Procedure for Testing and Certification of April 2004.				
Head of certification body:  (Prof. Dr. rer. nat. Diemar Reimer)		Certification officer:  (Dipl.-Ing. K. Apfeld)		
FZS/DE 01-05		Postal address: 53754 Sankt Augustin	Office: Alte Hauptstraße 111 53757 Sankt Augustin	Phone: 0 22 41/2 31-02 Fax: 0 22 41/2 31-22 34

### 2.1.8 IT mains



#### IT Mains

Do not connect frequency converters with RFI-filters to mains supplies with a voltage between phase and earth of more than 440 V for 400 V converters and 760 V for 690 V converters.

For 400 V IT mains and delta earth (grounded leg), mains voltage may exceed 440 V between phase and earth.

For 690 V IT mains and delta earth (grounded leg), mains voltage may exceed 760 V between phase and earth.

par. 14-50 *RFI Filter* can be used to disconnect the internal RFI capacitors from the RFI filter to ground.

### 2.1.9 Disposal instruction



Equipment containing electrical components must not be disposed of together with domestic waste. It must be separately collected with electrical and electronic waste according to local and currently valid legislation.

## 3 Introduction

### 3.1.1 Type Code String

1	2	3	4	5	6	7	8	9	10	11	12	13	14	15	16	17	18	19	20	21	22	23	24	25	26	27	28	29	30	31	32	33	34	35	36	37	38	39												
FC-	202		P						T										H										X		X		X		X		X		A		B		C						D	
130BA484.10																																																		



Description	Pos.:	Possible choice
Product group & VLT Series	1-6	FC 202
Power rating	7-10	0.25 - 1200 kW
Number of phases	11	Three phases (T)
Mains voltage	11-12	S2: 220-240 VAC single phase S4: 380-480 VAC single phase T 2: 200-240 VAC T 4: 380-480 VAC T 6: 525-600 VAC T 7: 525-690 VAC
Enclosure	13-15	E20: IP20 E21: IP 21/NEMA Type 1 E55: IP 55/NEMA Type 12 E2M: IP21/NEMA Type 1 w/mains shield E5M: IP 55/NEMA Type 12 w/mains shield E66: IP66 F21: IP21 kit without backplate G21: IP21 kit with backplate P20: IP20/Chassis with backplate P21: IP21/NEMA Type 1 w/backplate P55: IP55/NEMA Type 12 w/backplate
RFI filter	16-17	HX: No RFI filter H1: RFI filter class A1/B H2: RFI filter class A2 H3: RFI filter class A1/B (reduced cable length) H4: RFI filter class A2/A1
Brake	18	X: No brake chopper included B: Brake chopper included T: Safe Stop U: Safe + brake
Display	19	G: Graphical Local Control Panel (GLCP) N: Numeric Local Control Panel (NLCP) X: No Local Control Panel
Coating PCB	20	X: No coated PCB C: Coated PCB
Mains option	21	D: Loadsharing X: No Mains disconnect switch 8: Mains Disconnect + Loadsharing
Cable entries	22	X: Standard cable entries O: European metric thread in cable entries
Software release	24-27	Reserved
Software language	28	Actual software version
A options	29-30	AX: No options A0: MCA 101 Profibus DP V1 A4: MCA 104 DeviceNet AN: MCA 121 Ethernet IP
B options	31-32	BX: No option BK: MCB 101 General purpose I/O option BP: MCB 105 Relay option BO: MCB 109 Analog I/O option BY: MCO 101 Extended Cascade Control
C <sub>0</sub> options	33-34	CX: No options
C <sub>1</sub> options	35	X: No options 5: MCO 102 Advanced Cascade Control
C option software	36-37	XX: Standard software
D options	38-39	DX: No option D0: DC backup
The various options are described further in this Design Guide.		

Table 3.1: Type code description.

### 3.1.2 Frequency Converter Identification

Below is an example of an identification label. This label is situated on the frequency converter and shows the type and options fitted to the unit. See table 2.1 for details of how to read the Type code string (T/C).

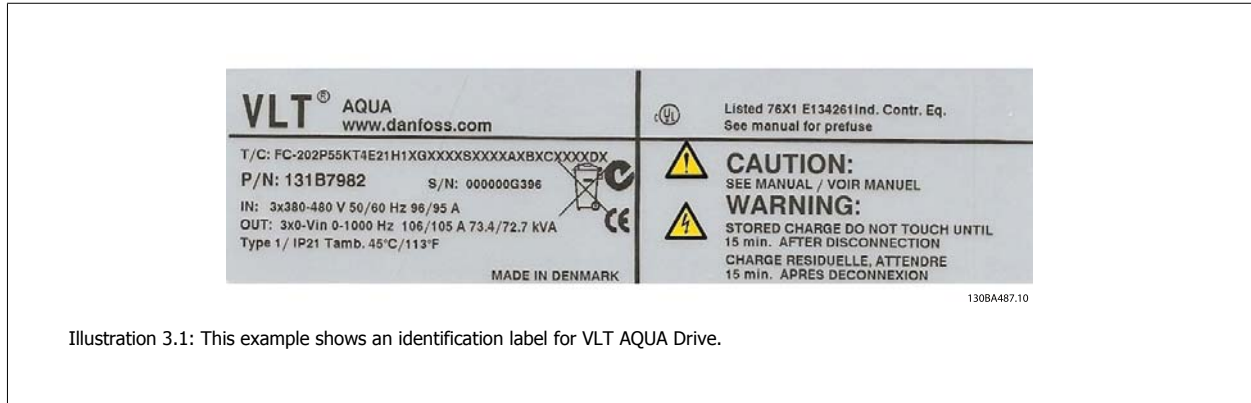


Illustration 3.1: This example shows an identification label for VLT AQUA Drive.

Please have T/C (type code) number and serial number ready before contacting Danfoss.

### 3.1.3 Abbreviations and Standards

Abbreviations:	Terms:	SI-units:	I-P units:
a	Acceleration	m/s <sup>2</sup>	ft/s <sup>2</sup>
AWG	American wire gauge		
Auto Tune	Automatic Motor Tuning		
°C	Celsius		
I	Current	A	Amp
I <sub>LIM</sub>	Current limit		
Joule	Energy	J = N•m	ft-lb, Btu
°F	Fahrenheit		
FC	Frequency Converter		
f	Frequency	Hz	Hz
kHz	Kilohertz	kHz	kHz
LCP	Local Control Panel		
mA	Milliampere		
ms	Millisecond		
min	Minute		
MCT	Motion Control Tool		
M-TYPE	Motor Type Dependent		
Nm	Newton Metres		in-lbs
I <sub>M,N</sub>	Nominal motor current		
f <sub>M,N</sub>	Nominal motor frequency		
P <sub>M,N</sub>	Nominal motor power		
U <sub>M,N</sub>	Nominal motor voltage		
par.	Parameter		
PELV	Protective Extra Low Voltage		
Watt	Power	W	Btu/hr, hp
Pascal	Pressure	Pa = N/m <sup>2</sup>	psi, psf, ft of water
I <sub>INV</sub>	Rated Inverter Output Current		
RPM	Revolutions Per Minute		
SR	Size Related		
T	Temperature	C	F
t	Time	s	s,hr
T <sub>LIM</sub>	Torque limit		
U	Voltage	V	V

Table 3.2: Abbreviation and Standards table .

## 4 Mechanical installation

### 4.1 Before starting

#### 4.1.1 Checklist

When unpacking the frequency converter, ensure that the unit is undamaged and complete. Use the following table to identify the packaging:

Enclosure type:	A2 (IP 20/ 21)	A3 (IP 20/21)	A5 (IP 55/ 66)	B1/B3 (IP20/ 21/ 55/ 66)	B2/B4 (IP20/ 21/ 55/66)	C1/C3 (IP20/21/ 55/66)	C2/C4 (IP20/21/ 55/66)
<b>Unit size (kW):</b>							
200-240 V	0.25-3.0	3.7	0.25-3.7	5.5-11/ 5.5-11	15/ 15-18.5	18.5-30/ 22-30	37-45/ 37-45
380-480 V	0.37-4.0	5.5-7.5	0.37-7.5	11-18.5/ 11-18.5	22-30/ 22-37	37-55/ 45-55	75 - 90/ 75-90
525-600 V		0.75-7.5	0.75-7.5	11-18.5/ 11-18.5	22-37/ 22-37	45-55/ 45-55	75 - 90/ 75-90

Table 4.1: Unpacking table

Please note that a selection of screwdrivers (philips or cross-thread screwdriver and torx), a side-cutter, drill and knife is also recommended to have handy for unpacking and mounting the frequency converter. The packaging for these enclosures contains, as shown: Accessories bag(s), documentation and the unit. Depending on options fitted there may be one or two bags and one or more booklets.

4

4.2.1 Mechanical Front Views

IP20/21	IP20/21	IP55/66	IP21/55/66	IP21/55/66	IP20	IP20	IP21/55/66	IP21/55/66	IP20	IP20
<p>Illustration 4.1: Top and bottom mounting holes.</p>						<p>Illustration 4.2: Top and bottom mounting holes. (B4+C3+C4 only)</p>				
<p>Accessory bags containing necessary brackets, screws and connectors are included with the drives upon delivery.</p>										
<p>All measurements in mm.</p>										

### 4.2.2 Mechanical Dimensions

Frame size (kW):	Mechanical dimensions											
	A2	A3	A5	B1	B2	B3	B4	C1	C2	C3	C4	
200-240 V	0.25-3.0	3.7	0.25-3.7	5.5-11	15	5.5-11	15-18.5	18.5-30	37-45	22-30	37-45	
380-480 V	0.37-4.0	5.5-7.5	0.37-7.5	11-18.5	22-30	11-18.5	22-37	37-55	75-90	45-55	75-90	
525-600 V	-	0.75-7.5	0.75-7.5	11-18.5	22-30	11-18.5	22-37	37-55	75-90	45-55	75-90	
525-690 V	-	-	-	-	11-30	-	-	-	37-90	-	-	
TP	20	21	55/66	21/55/66	21/55/66	20	20	21/55/66	21/55/66	20	20	
NEMA	Chassis	Chassis	Type 12	Type 1/12	Type 1/12	Chassis	Chassis	Type 1/12	Type 1/12	Chassis	Chassis	
<b>Height (mm)</b>												
Enclosure	A**	246	372	420	480	350	460	680	770	490	600	
.with de-coupling plate	A2	374	-	-	-	419	595	-	-	630	800	
Back plate	A1	268	375	420	480	399	520	680	770	550	660	
Distance between mount. holes	a	257	350	402	454	380	495	648	739	521	631	
<b>Width (mm)</b>												
Enclosure	B	90	130	242	242	165	231	308	370	308	370	
With one C option	B	130	170	242	242	205	231	308	370	308	370	
Back plate	B	90	130	242	242	165	231	308	370	308	370	
Distance between mount. holes	b	70	110	215	210	140	200	272	334	270	330	
<b>Depth (mm)</b>												
Without option A/B	C	205	205	200	260	248	242	310	335	333	333	
With option A/B	C*	220	220	200	260	262	242	310	335	333	333	
<b>Screw holes (mm)</b>												
	c	8,0	8,0	8,2	12	8	-	12	12	-	-	
Diameter ø	d	11	11	12	19	12	-	19	19	-	-	
Diameter ø	e	5,5	5,5	6,5	9	6,8	8,5	9,0	9,0	8,5	8,5	
	f	9	9	9	9	7,9	15	9,8	9,8	17	17	
<b>Max weight (kg)</b>												
		4,9	5,3	14	23	12	23,5	45	65	35	50	

\* Depth of enclosure will vary with different options installed.

\*\* The free space requirements are above and below the bare enclosure height measurement A. See section 3.2.3 for further information.

### 4.2.3 Mechanical mounting

All IP20 enclosure sizes as well as IP21/ IP55 enclosure sizes except A2 and A3 allow side-by-side installation.

If the IP 21 Enclosure kit (130B1122 or 130B1123) is used on enclosure A2 or A3, there must be a clearance between the drives of min. 50 mm.

For optimal cooling conditions allow a free air passage above and below the frequency converter. See table below.

**Air passage for different enclosures**

Enclosure:	A2	A3	A5	B1	B2	B3	B4	C1	C2	C3	C4
a (mm):	100	100	100	200	200	200	200	200	225	200	225
b (mm):	100	100	100	200	200	200	200	200	225	200	225

1. Drill holes in accordance with the measurements given.
2. You must provide screws suitable for the surface on which you want to mount the frequency converter. Re-tighten all four screws.

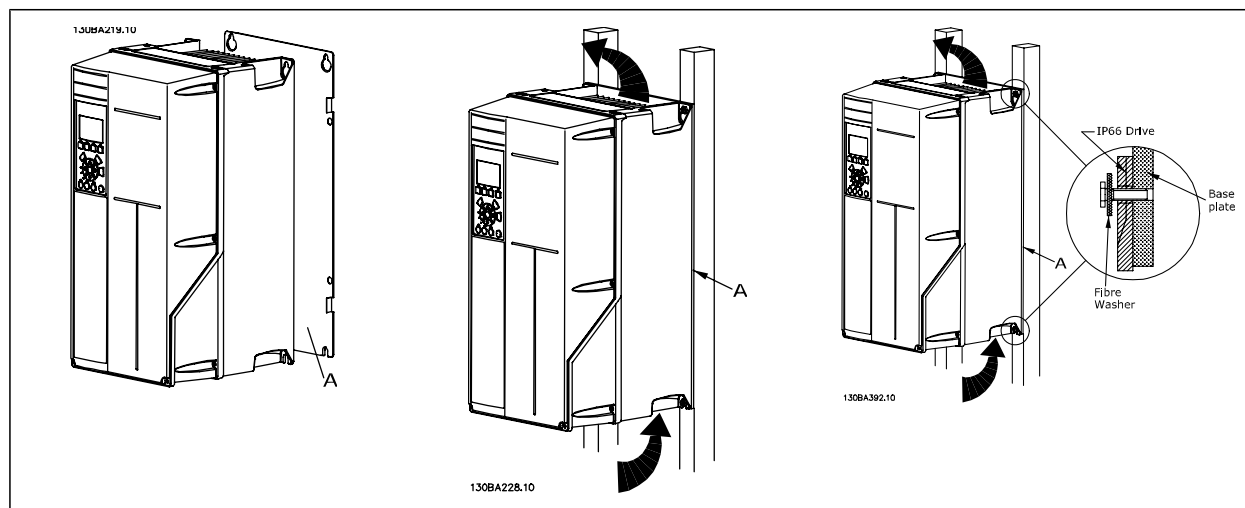


Table 4.2: Mounting frame sizes A5, B1, B2, B3, B4, C1, C2, C3 and C4 on a non-solid back wall, the drive must be provided with a back plate A due to insufficient cooling air over the heat sink.

With heavier drives (B4, C3, C4) use a lift. First wall-mount the 2 lower bolts - then lift the drive onto the lower bolts - finally fasten the drive against the wall with the 2 top bolts.

### 4.2.4 Safety Requirements of Mechanical Installation

!

Pay attention to the requirements that apply to integration and field mounting kit. Observe the information in the list to avoid serious damage or injury, especially when installing large units.

The frequency converter is cooled by means of air circulation.

To protect the unit from overheating, it must be ensured that the ambient temperature *does not exceed the maximum temperature stated for the frequency converter* and that the 24-hour average temperature *is not exceeded*. Locate the maximum temperature and 24-hour average in the paragraph *Derating for Ambient Temperature*.



If the ambient temperature is in the range of 45 °C - 55 ° C, derating of the frequency converter will become relevant, see *Derating for Ambient Temperature*.

The service life of the frequency converter is reduced if derating for ambient temperature is not taken into account.

#### 4.2.5 Field Mounting

For field mounting the IP 21/IP 4X top/TYPE 1 kits or IP 54/55 units are recommended.

#### 4.2.6 Panel Through Mounting

A Panel Through Mount Kit is available for frequency converter series , VLT Aqua Drive and .

In order to increase heatsink cooling and reduce panel depth, the frequency converter may be mounted in a through panel. Furthermore the in-built fan can then be removed.

The kit is available for enclosures A5 through C2.



**NB!**

This kit cannot be used with cast front covers. No cover or IP21 plastic cover must be used instead.

Information on ordering numbers is found in the *Design Guide*, section *Ordering Numbers*.

More detailed information is available in the *Panel Through Mount Kit instruction*, MI.33.H1.YY, where yy=language code.

**5**

## 5 Electrical installation

### 5.1 How to connect

#### 5.1.1 Cables General



**NB!**

Always comply with national and local regulations on cable cross-sections.

#### Details of terminal tightening torques.

Enclosure	Power (kW)			Torque (Nm)					
	200-240 V	380-480 V	525-600 V	Mains	Motor	DC connection	Brake	Earth	Relay
A2	0.25 - 3.0	0.37 - 4.0		1.8	1.8	1.8	1.8	3	0.6
A3	3.7	5.5 - 7.5	0.75 - 7.5	1.8	1.8	1.8	1.8	3	0.6
A5	0.25 - 3.7	0.37 - 7.5	0.75 - 7.5	1.8	1.8	1.8	1.8	3	0.6
B1	5.5 - 11	11 - 18.5	-	1.8	1.8	1.5	1.5	3	0.6
B2	-	22	-	4.5	4.5	3.7	3.7	3	0.6
	15	30	-	4.5 <sup>2)</sup>	4.5 <sup>2)</sup>	3.7	3.7	3	0.6
B3	5.5 - 11	11 - 18.5	11 - 18.5	1.8	1.8	1.8	1.8	3	0.6
B4	15 - 18.5	22 - 37	22 - 37	4.5	4.5	4.5	4.5	3	0.6
C1	18.5 - 30	37 - 55	-	10	10	10	10	3	0.6
C2	37	75	-	14	14	14	14	3	0.6
	45	90	-	24	24	14	14	3	0.6
C3	22 -	45 -	45 -	10	10	10	10	3	0.6
	30	55	55						
C4	37 -	75 -	75 -	14	14	14	14	3	0.6
	45	90	90	24 <sup>1)</sup>	24 <sup>1)</sup>				

Table 5.1: Tightening of terminals

1. For different cable dimensions x/y where  $x \leq 95 \text{ mm}^2$  and  $y \geq 95 \text{ mm}^2$ .
2. Cable dimensions above 18.5 kW  $\geq 35 \text{ mm}^2$  and below 22 kW  $\leq 10 \text{ mm}^2$

#### 5.1.2 Enclosure Knock-outs

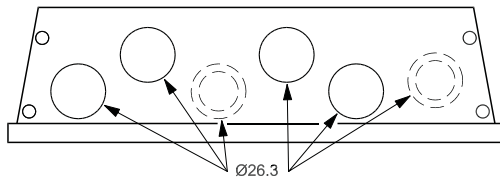


Illustration 5.1: Cable entry holes for enclosure A5. The suggested use of the holes are purely recommendations and other solutions are possible.

5

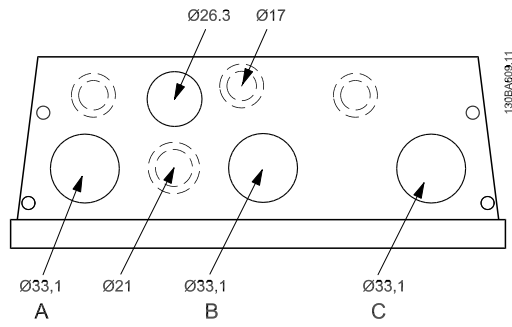


Illustration 5.2: Cable entry holes for enclosure B1. The suggested use of the holes are purely recommendations and other solutions are possible.

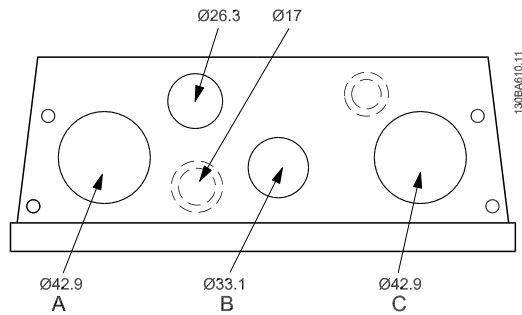


Illustration 5.3: Cable entry holes for enclosure B2. The suggested use of the holes are purely recommendations and other solutions are possible.

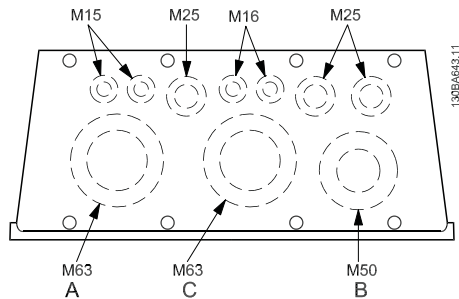
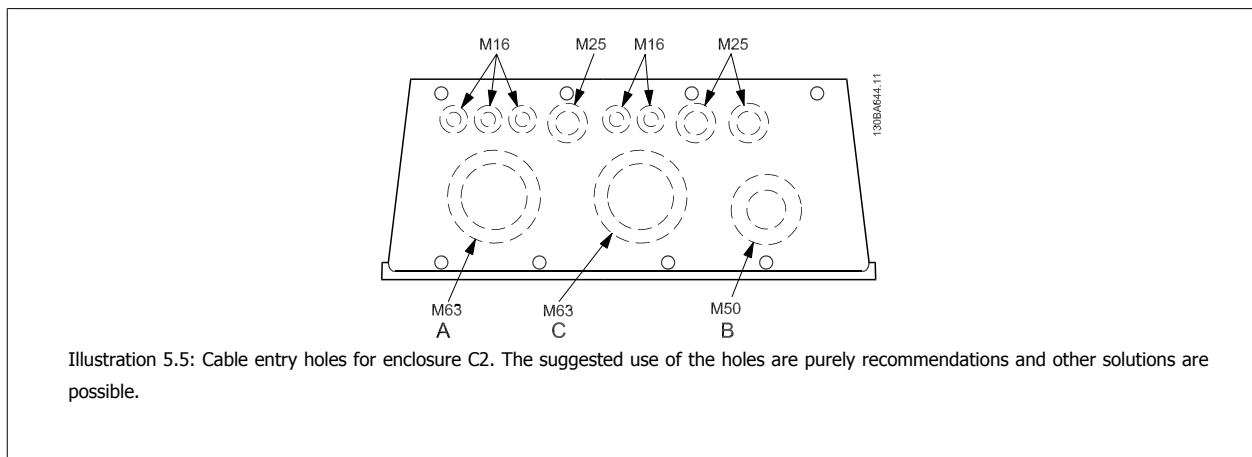


Illustration 5.4: Cable entry holes for enclosure C1. The suggested use of the holes are purely recommendations and other solutions are possible.



5

### 5.1.3 Fuses

**Branch circuit protection:**

In order to protect the installation against electrical and fire hazard, all branch circuits in an installation, switch gear, machines etc., must be shortcircuit and overcurrent protected according to the national/international regulations.

**Short circuit protection**

The frequency converter must be protected against short-circuit to avoid electrical or fire hazard. Danfoss recommends using the fuses mentioned in tables 4.3 and 4.4 to protect service personnel or other equipment in case of an internal failure in the unit. The frequency converter provides full short circuit protection in case of a short-circuit on the motor output.

**Over-current protection:**

Provide overload protection to avoid fire hazard due to overheating of the cables in the installation. Over current protection must always be carried out according to national regulations. The frequency converter is equipped with an internal over current protection that can be used for upstream overload protection (UL-applications excluded). See par. 4-18. Fuses must be designed for protection in a circuit capable of supplying a maximum of 100,000 A<sub>rms</sub> (symmetrical), 500 V/600 V maximum.

**Non UL compliance**

If UL/cUL is not to be complied with, Danfoss recommends using the fuses mentioned in table 4.2, which will ensure compliance with EN50178: In case of malfunction, not following the recommendation may result in unnecessary damage to the frequency converter.

Frequency converter	Max. fuse size	Voltage	Type
<b>200-240 V</b>			
K25-1K1	16A <sup>1</sup>	200-240 V	type gG
1K5	16A <sup>1</sup>	200-240 V	type gG
2K2	25A <sup>1</sup>	200-240 V	type gG
3K0	25A <sup>1</sup>	200-240 V	type gG
3K7	35A <sup>1</sup>	200-240 V	type gG
5K5	50A <sup>1</sup>	200-240 V	type gG
7K5	63A <sup>1</sup>	200-240 V	type gG
11K	63A <sup>1</sup>	200-240 V	type gG
15K	80A <sup>1</sup>	200-240 V	type gG
18K5	125A <sup>1</sup>	200-240 V	type gG
22K	125A <sup>1</sup>	200-240 V	type gG
30K	160A <sup>1</sup>	200-240 V	type gG
37K	200A <sup>1</sup>	200-240 V	type aR
45K	250A <sup>1</sup>	200-240 V	type aR
<b>380-480 V</b>			
K37-1K5	10A <sup>1</sup>	380-480 V	type gG
2K2-4K0	20A <sup>1</sup>	380-480 V	type gG
5K5-7K5	32A <sup>1</sup>	380-480 V	type gG
11K	63A <sup>1</sup>	380-480 V	type gG
15K	63A <sup>1</sup>	380-480 V	type gG
18K	63A <sup>1</sup>	380-480 V	type gG
22K	63A <sup>1</sup>	380-480 V	type gG
30K	80A <sup>1</sup>	380-480 V	type gG
37K	100A <sup>1</sup>	380-480 V	type gG
45K	125A <sup>1</sup>	380-480 V	type gG
55K	160A <sup>1</sup>	380-480 V	type gG
75K	250A <sup>1</sup>	380-480 V	type aR
90K	250A <sup>1</sup>	380-480 V	type aR

Table 5.2: Non UL fuses 200 V to 480 V

1) Max. fuses - see national/international regulations for selecting an applicable fuse size.

#### UL Compliance

Frequency converter	Bussmann	Bussmann	Bussmann	SIBA	Littel fuse	Ferraz-Shawmut	Ferraz-Shawmut
<b>200-240 V</b>							
Type	Type RK1	Type J	Type T	Type RK1	Type RK1	Type CC	Type RK1
K25-1K1	KTN-R10	JKS-10	JJN-10	5017906-010	KLN-R10	ATM-R10	A2K-10R
1K5	KTN-R15	JKS-15	JJN-15	5017906-015	KLN-R15	ATM-R15	A2K-15R
2K2	KTN-R20	JKS-20	JJN-20	5012406-020	KLN-R20	ATM-R20	A2K-20R
3K0	KTN-R25	JKS-25	JJN-25	5012406-025	KLN-R25	ATM-R25	A2K-25R
3K7	KTN-R30	JKS-30	JJN-30	5012406-030	KLN-R30	ATM-R30	A2K-30R
5K5	KTN-R50	JKS-50	JJN-50	5012406-050	KLN-R50	-	A2K-50R
7K5	KTN-R50	JKS-60	JJN-60	5012406-050	KLN-R60	-	A2K-50R
11K	KTN-R60	JKS-60	JJN-60	5014006-063	KLN-R60	-	A2K-60R
15K	KTN-R80	JKS-80	JJN-80	5014006-080	KLN-R80	-	A2K-80R
18K5	KTN-R125	JKS-150	JJN-125	2028220-125	KLN-R125	-	A2K-125R
22K	KTN-R125	JKS-150	JJN-125	2028220-125	KLN-R125	-	A2K-125R
30K	FWX-150	-	-	2028220-150	L25S-150	-	A25X-150
37K	FWX-200	-	-	2028220-200	L25S-200	-	A25X-200
45K	FWX-250	-	-	2028220-250	L25S-250	-	A25X-250

Table 5.3: UL fuses 200 - 240 V

Frequency converter	Bussmann	Bussmann	Bussmann	SIBA	Littel fuse	Ferraz-Shawmut	Ferraz-Shawmut
<b>380-480 V, 525-600 V</b>							
kW	Type RK1	Type J	Type T	Type RK1	Type RK1	Type CC	Type RK1
K37-1K1	KTS-R6	JKS-6	JJS-6	5017906-006	KLS-R6	ATM-R6	A6K-6R
1K5-2K2	KTS-R10	JKS-10	JJS-10	5017906-010	KLS-R10	ATM-R10	A6K-10R
3K0	KTS-R15	JKS-15	JJS-15	5017906-016	KLS-R16	ATM-R16	A6K-16R
4K0	KTS-R20	JKS-20	JJS-20	5017906-020	KLS-R20	ATM-R20	A6K-20R
5K5	KTS-R25	JKS-25	JJS-25	5017906-025	KLS-R25	ATM-R25	A6K-25R
7K5	KTS-R30	JKS-30	JJS-30	5012406-032	KLS-R30	ATM-R30	A6K-30R
11K	KTS-R40	JKS-40	JJS-40	5014006-040	KLS-R40	-	A6K-40R
15K	KTS-R40	JKS-40	JJS-40	5014006-040	KLS-R40	-	A6K-40R
18K	KTS-R50	JKS-50	JJS-50	5014006-050	KLS-R50	-	A6K-50R
22K	KTS-R60	JKS-60	JJS-60	5014006-063	KLS-R60	-	A6K-60R
30K	KTS-R80	JKS-80	JJS-80	2028220-100	KLS-R80	-	A6K-80R
37K	KTS-R100	JKS-100	JJS-100	2028220-125	KLS-R100	-	A6K-100R
45K	KTS-R125	JKS-150	JJS-150	2028220-125	KLS-R125	-	A6K-125R
55K	KTS-R150	JKS-150	JJS-150	2028220-160	KLS-R150	-	A6K-150R
75K	FWH-220	-	-	2028220-200	L50S-225	-	A50-P225
90K	FWH-250	-	-	2028220-250	L50S-250	-	A50-P250

Table 5.4: UL fuses 380 - 600 V

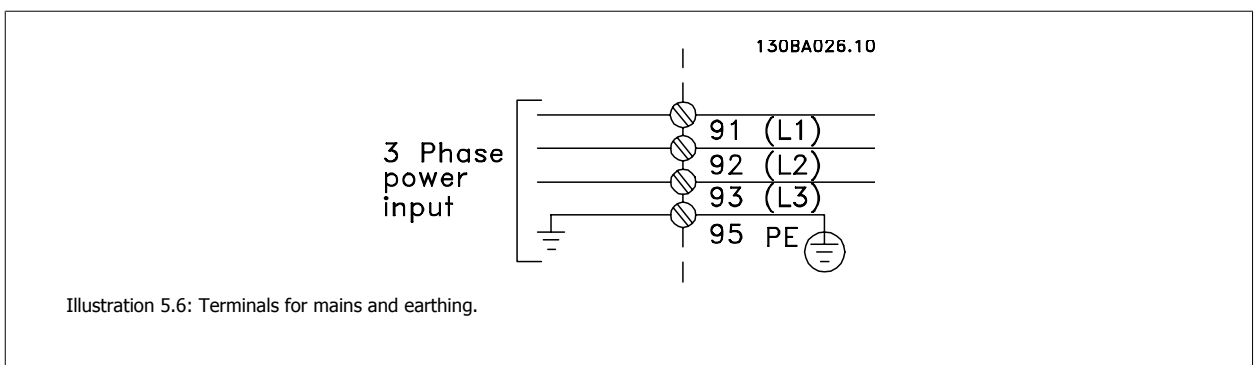
- KTS-fuses from Bussmann may substitute KTN for 240 V frequency converters.
- FWH-fuses from Bussmann may substitute FWX for 240 V frequency converters.
- KLSR fuses from LITTEL FUSE may substitute KLNK fuses for 240 V frequency converters.
- L50S fuses from LITTEL FUSE may substitute L50S fuses for 240 V frequency converters.
- A6KR fuses from FERRAZ SHAWMUT may substitute A2KR for 240 V frequency converters.
- A50X fuses from FERRAZ SHAWMUT may substitute A25X for 240 V frequency converters.

### 5.1.4 Earthing and IT mains

The earth connection cable cross section must be at least 10 mm<sup>2</sup> or 2 rated mains wires terminated separately according to *EN 50178* or *IEC 61800-5-1* unless national regulations specify differently. Always comply with national and local regulations on cable cross-sections.

The mains is connected to the main disconnect switch if this is included.

**NB!**  
Check that mains voltage corresponds to the mains voltage of the frequency converter name plate.



**IT Mains**

Do not connect 400 V frequency converters with RFI-filters to mains supplies with a voltage between phase and earth of more than 440 V.

For IT mains and delta earth (grounded leg), mains voltage may exceed 440 V between phase and earth.



### 5.1.5 Mains wiring overview












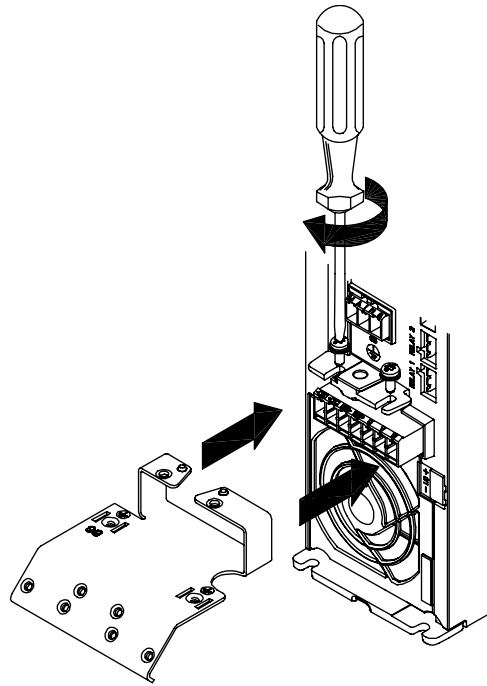
Enclosure:	A2 (IP 20/IP 21)	A3 (IP 20/IP 21)	A5 (IP 55/IP 66)	B1 (IP 21/IP 55/IP 66)	B2 (IP 21/IP 55/IP 66)	B3 (IP 20)	B4 (IP 20)	C1 (IP 21/IP 55/66)	C2 (IP 21/IP 55/66)	C3 (IP 20)	C4 (IP20)
											
<b>Motor size (kW):</b>											
200-240 V	0.25-3.0	3.7	1.1-3.7	5.5-11	15	5.5-11	15-18.5	18.5-30	37-45	22-30	37-45
380-480 V	0.37-4.0	5.5-7.5	1.1-7.5	11-18.5	22-30	11-18.5	22-37	37-55	75-90	45-55	75-90
525-600 V		1.1-7.5	1.1-7.5	11-18.5	22-30	11-18.5	22-37	37-55	75-90	45-55	75-90
<b>Goto:</b>	<b>5.1.6</b>	<b>5.1.6</b>	<b>5.1.7</b>	<b>5.1.8</b>	<b>5.1.8</b>	<b>5.1.8</b>	<b>5.1.9</b>	<b>5.1.9</b>	<b>5.1.9</b>	<b>5.1.10</b>	<b>5.1.10</b>

Table 5.5: Mains wiring table.

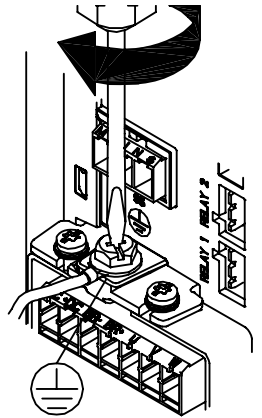
## 5.1.6 Mains connection for A2 and A3

5



130BA261.10

Illustration 5.7: First mount the two screws on the mounting plate, slide it into place and tighten fully.

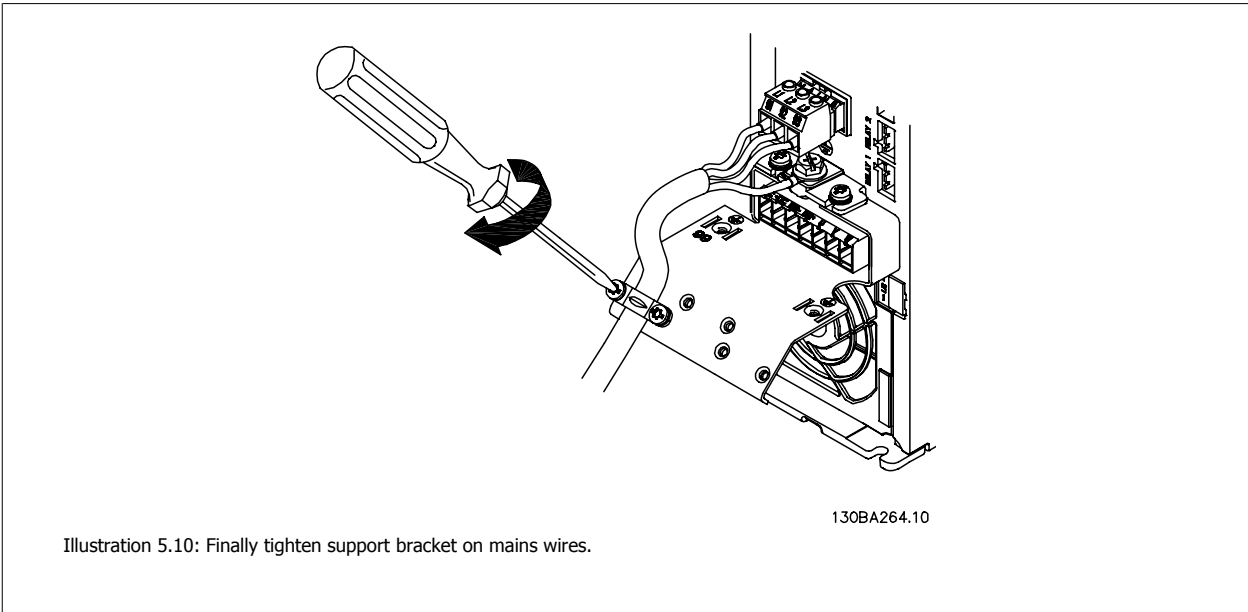
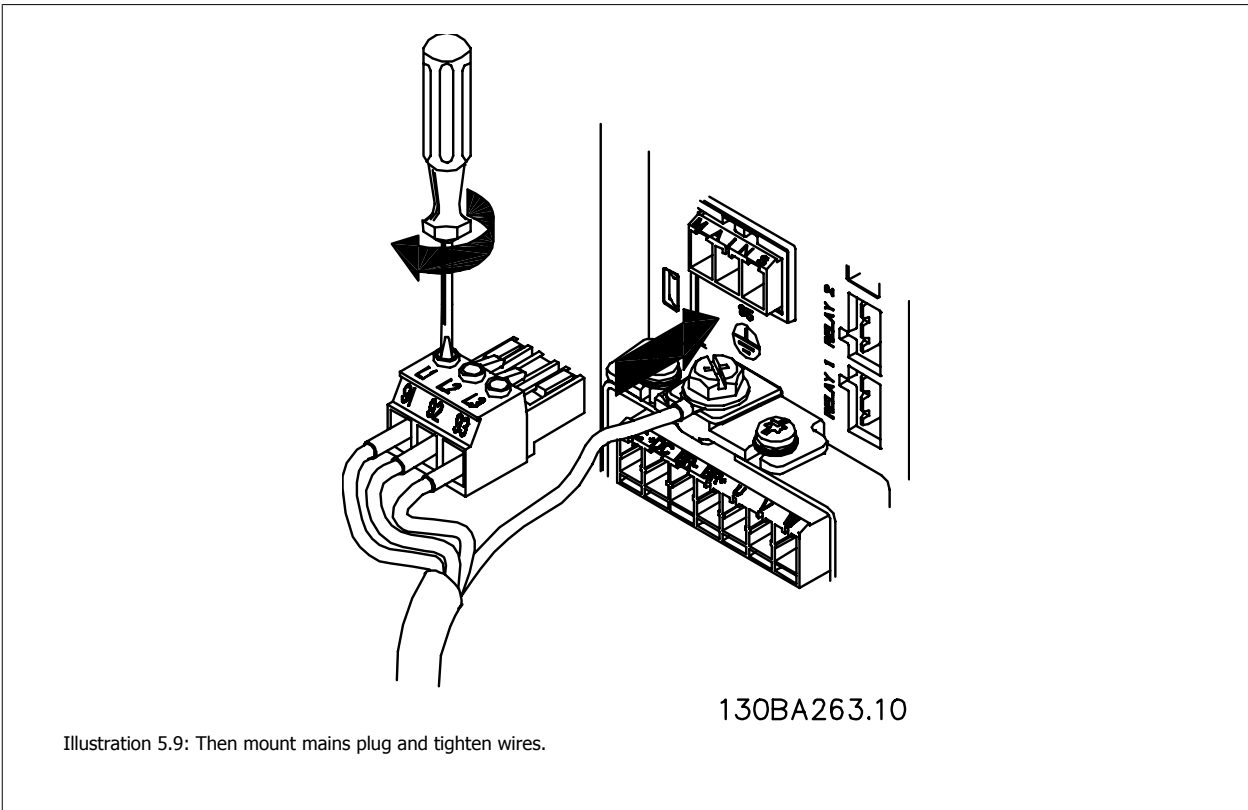


130BA262.1C

Illustration 5.8: When mounting cables, first mount and tighten earth cable.



The earth connection cable cross section must be at least 10 mm<sup>2</sup> or 2 rated mains wires terminated separately according to *EN 50178/IEC 61800-5-1*.



**NB!**  
With single phase A3 use L1 and L2 terminals.

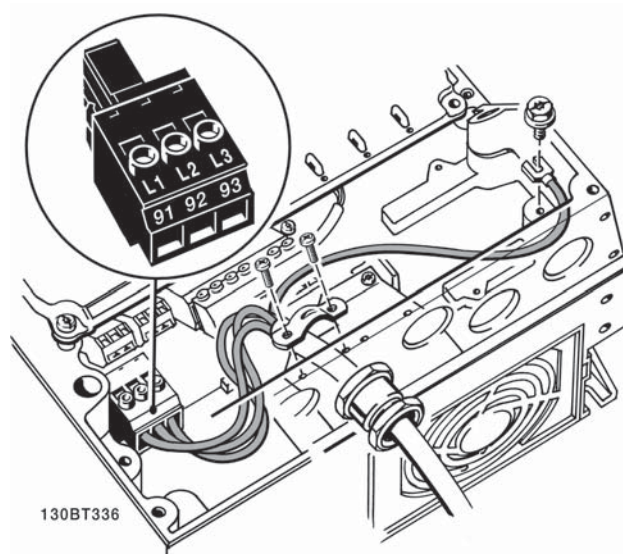
**5.1.7 Mains connection for A5****5**

Illustration 5.11: How to connect to mains and earthing without mains disconnect switch. Note that a cable clamp is used.

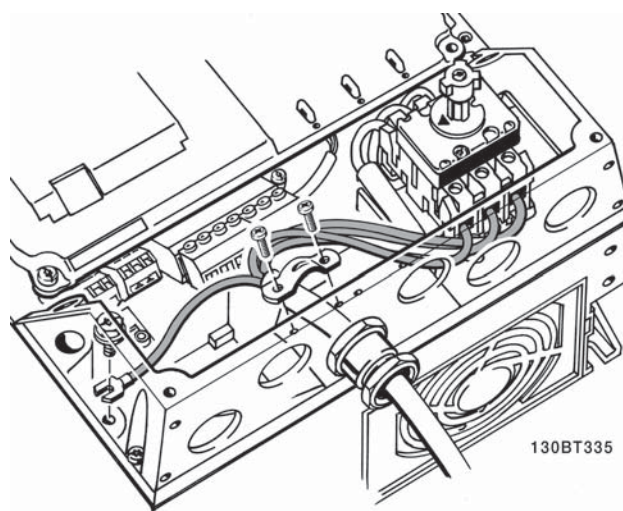
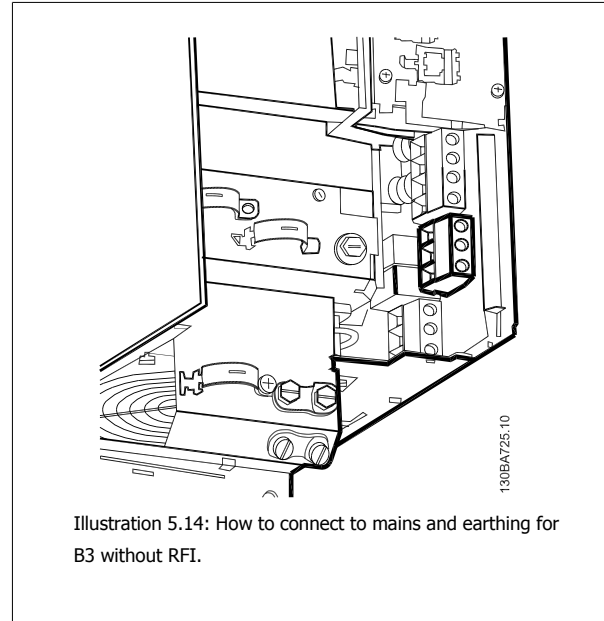
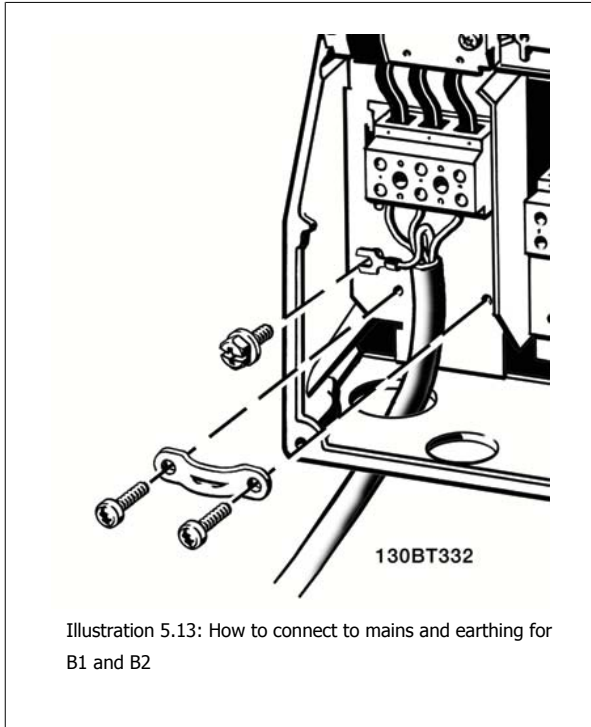


Illustration 5.12: How to connect to mains and earthing with mains disconnect switch.

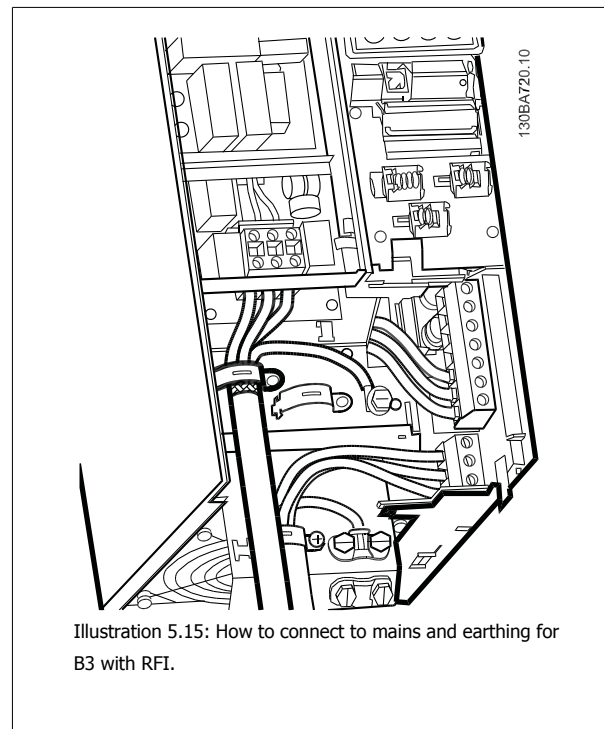
**NB!**

With single phase A5 use L1 and L2 terminals.


### 5.1.8 Mains connection for B1, B2 and B3



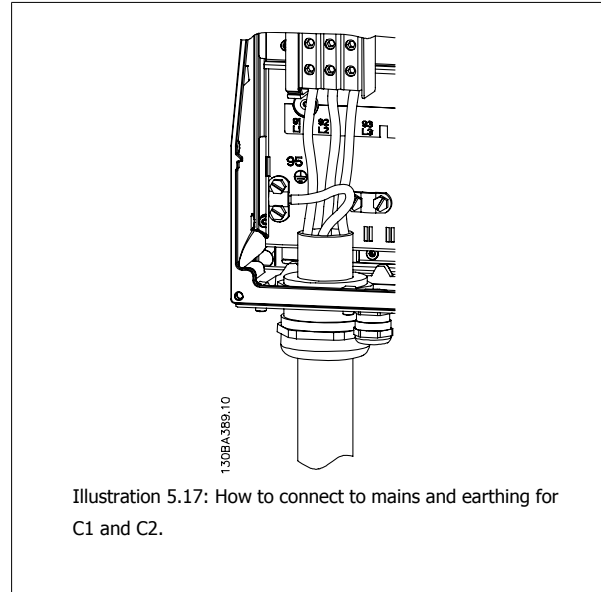
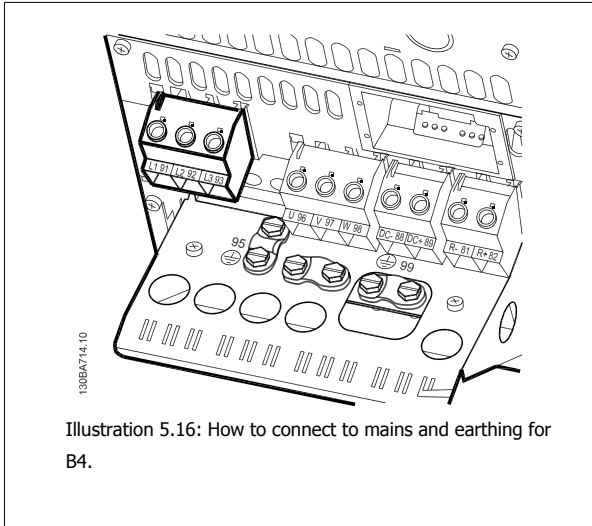
5



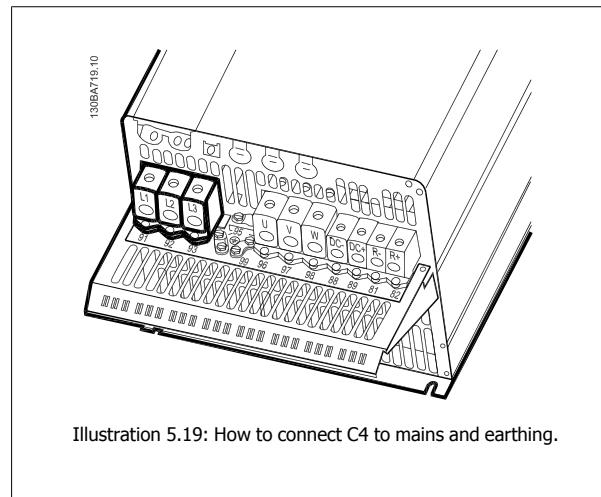
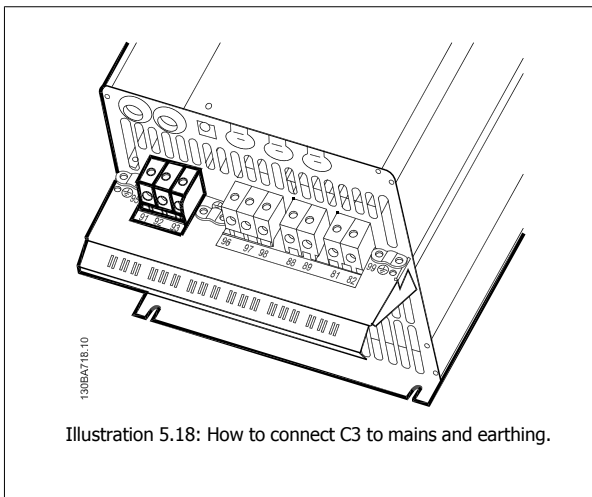
**NB!**  
With single phase B1 use L1 and L2 terminals.

 **NB!**  
For correct cable dimensions please see the section General Specifications at the back of this manual.

### 5.1.9 Mains connection for B4, C1 and C2



### 5.1.10 Mains connection for C3 and C4



### 5.1.11 How to connect motor - foreword

See section *General Specifications* for correct dimensioning of motor cable cross-section and length.

- Use a screened/armoured motor cable to comply with EMC emission specifications (or install the cable in metal conduit).
- Keep the motor cable as short as possible to reduce the noise level and leakage currents.
- Connect the motor cable screen/armour to both the decoupling plate of the frequency converter and to the metal of the motor. (Same applies to both ends of metal conduit if used instead of screen.)
- Make the screen connections with the largest possible surface area (cable clamp or by using an EMC cable gland). This is done by using the supplied installation devices in the frequency converter.
- Avoid terminating the screen by twisting the ends (pigtailed), as this will spoil high frequency screening effects.
- If it is necessary to break the continuity of the screen to install a motor isolator or motor relay, the continuity must be maintained with the lowest possible HF impedance.

**Cable length and cross-section**

The frequency converter has been tested with a given length of cable and a given cross-section of that cable. If the cross-section is increased, the cable capacitance - and thus the leakage current - may increase, and the cable length must be reduced correspondingly.

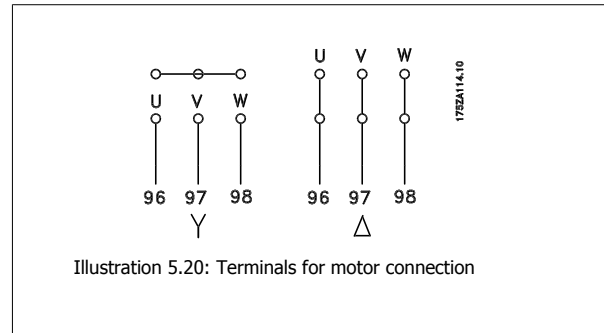
**Switching frequency**

When frequency converters are used together with sine wave filters to reduce the acoustic noise from a motor, the switching frequency must be set according to the sine wave filter instruction in par. 14-01 *Switching Frequency*.

**Precautions while using Aluminium conductors**

Aluminium conductors are not recommended for cable cross sections below 35 mm<sup>2</sup>. Terminals can accept aluminium conductors but the conductor surface has to be clean and the oxidation must be removed and sealed by neutral acid free Vaseline grease before the conductor is connected. Furthermore, the terminal screw must be retightened after two days due to the softness of the aluminium. It is crucial to ensure the connection makes a gas tight joint, otherwise the aluminium surface will oxidize again.

All types of three-phase asynchronous standard motors can be connected to the frequency converter. Normally, small motors are star-connected (230/400 V, D/Y). Large motors are delta-connected (400/690 V, D/Y). Refer to the motor name plate for correct connection mode and voltage.



**NB!** In motors without phase insulation paper or other insulation reinforcement suitable for operation with voltage supply (such as a frequency converter), fit a sine-wave filter on the output of the frequency converter. (Motors that comply with IEC 60034-17 do not require an Sine-wave filter).

No.	96	97	98	Motor voltage 0-100% of mains voltage.
	U	V	W	3 cables out of motor
	U1	V1	W1	6 cables out of motor, Delta-connected
	W2	U2	V2	
	U1	V1	W1	6 cables out of motor, Star-connected
				U2, V2, W2 to be interconnected separately (optional terminal block)
No.	99			Earth connection
	PE			

Table 5.6: 3 and 6 cable motor connection.

**5.1.12 Motor wiring overview**

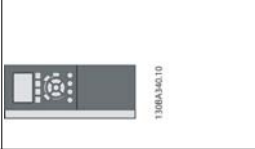
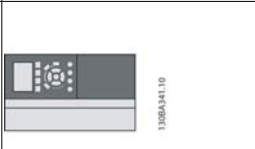
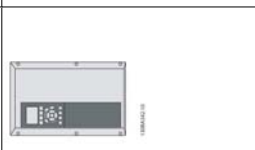
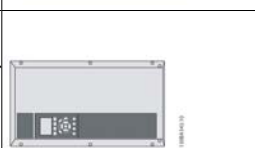







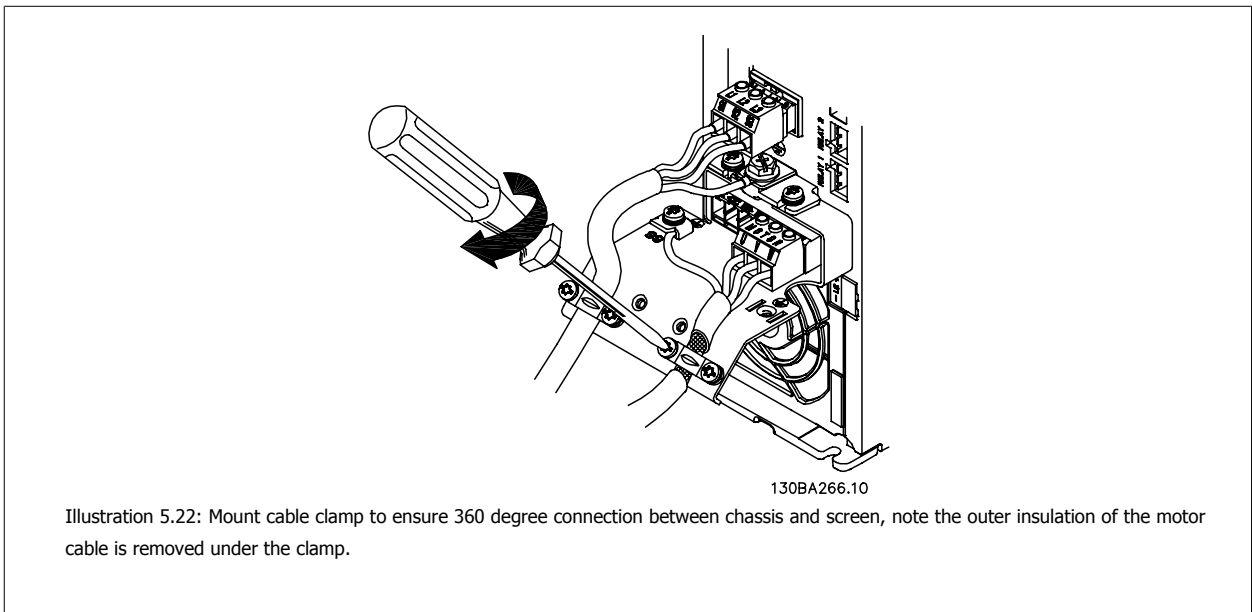
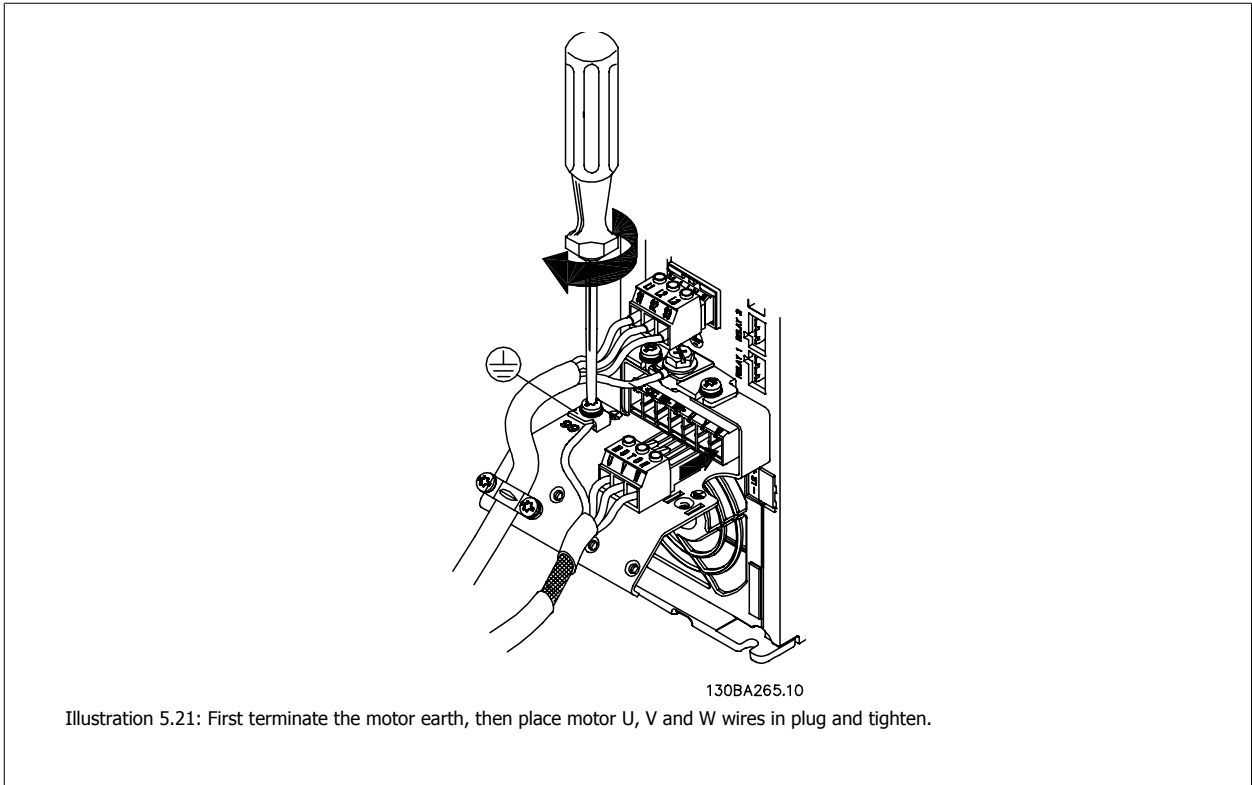
Enclosure:	A2 (IP 20/IP 21)	A3 (IP 20/IP 21)	A5 (IP 55/IP 66)	B1 (IP 21/IP 55/ IP 66)	B2 (IP 21/IP 55/ IP 66)	B3 (IP 20)	B4 (IP 20)	C1 (IP 21/IP 55/66)	C2 (IP 21/IP 55/66)	C3 (IP 20)	C4 (IP20)
											
<b>Motor size (kW):</b>	0.25-3.0	3.7	1.1-3.7	5.5-11	15	5.5-11	15-18.5	18.5-30	37-45	22-30	37-45
200-240 V	0.37-4.0	5.5-7.5	1.1-7.5	11-18.5	22-30	11-18.5	22-37	37-55	75-90	45-55	75-90
380-480 V		1.1-7.5	1.1-7.5	11-18.5	22-30	11-18.5	22-37	37-55	75-90	45-55	75-90
525-600 V		1.1-7.5	1.1-7.5	11-18.5	22-30	11-18.5	22-37	37-55	75-90	45-55	75-90
<b>Goto:</b>	<b>5.1.13</b>		<b>5.1.14</b>		<b>5.1.15</b>		<b>5.1.16</b>		<b>5.1.17</b>		<b>5.1.18</b>

Table 5.7: Motor wiring table.



### 5.1.13 Motor connection for A2 and A3

Follow these drawings step by step for connecting the motor to the frequency converter.



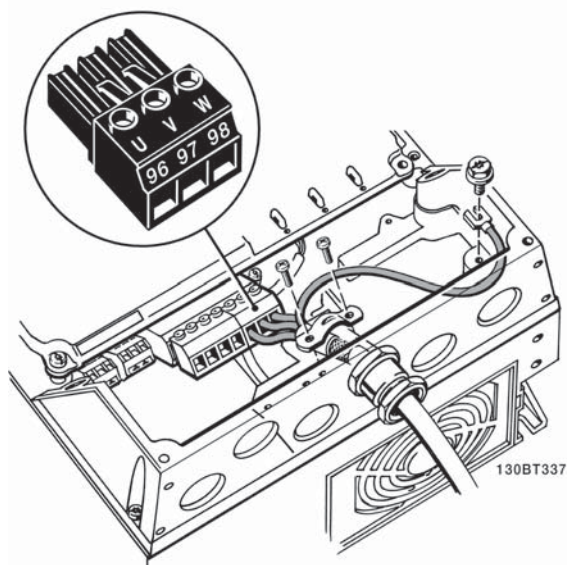
**5.1.14 Motor connection for A5**

Illustration 5.23: First terminate the motor earth, then place motor U, V and W wires in terminal and tighten. Please ensure that the outer insulation of the motor cable is removed under the EMC clamp.

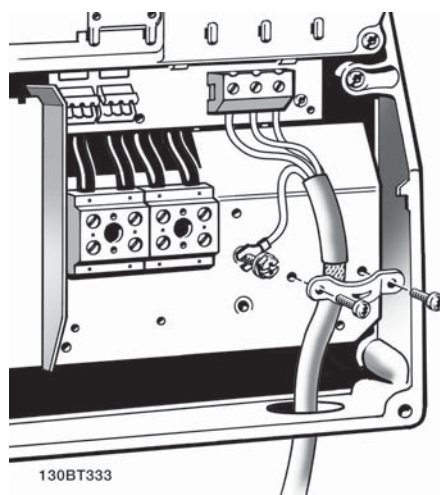
**5.1.15 Motor connection for B1 and B2**

Illustration 5.24: First terminate the motor earth, then Place motor U, V and W wires in terminal and tighten. Please ensure that the outer insulation of the motor cable is removed under the EMC clamp.

### 5.1.16 Motor connection for B3 and B4

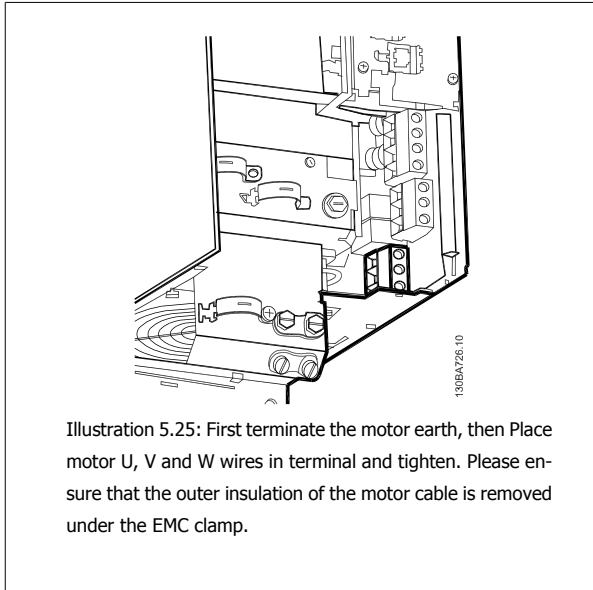


Illustration 5.25: First terminate the motor earth, then Place motor U, V and W wires in terminal and tighten. Please ensure that the outer insulation of the motor cable is removed under the EMC clamp.

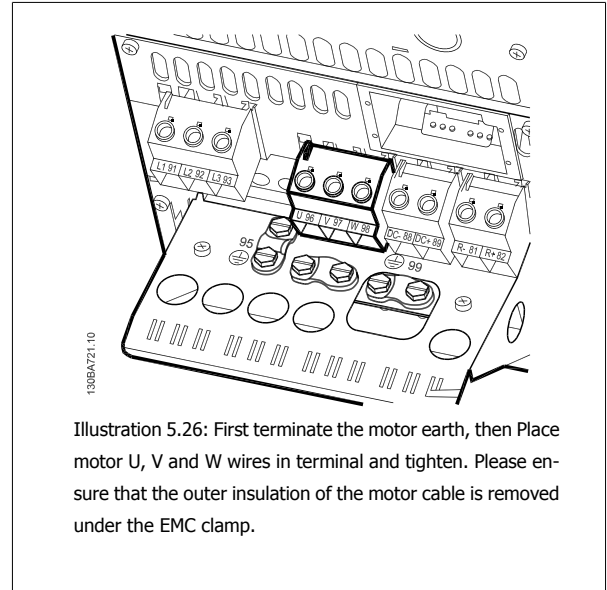


Illustration 5.26: First terminate the motor earth, then Place motor U, V and W wires in terminal and tighten. Please ensure that the outer insulation of the motor cable is removed under the EMC clamp.

5

### 5.1.17 Motor connection for C1 and C2

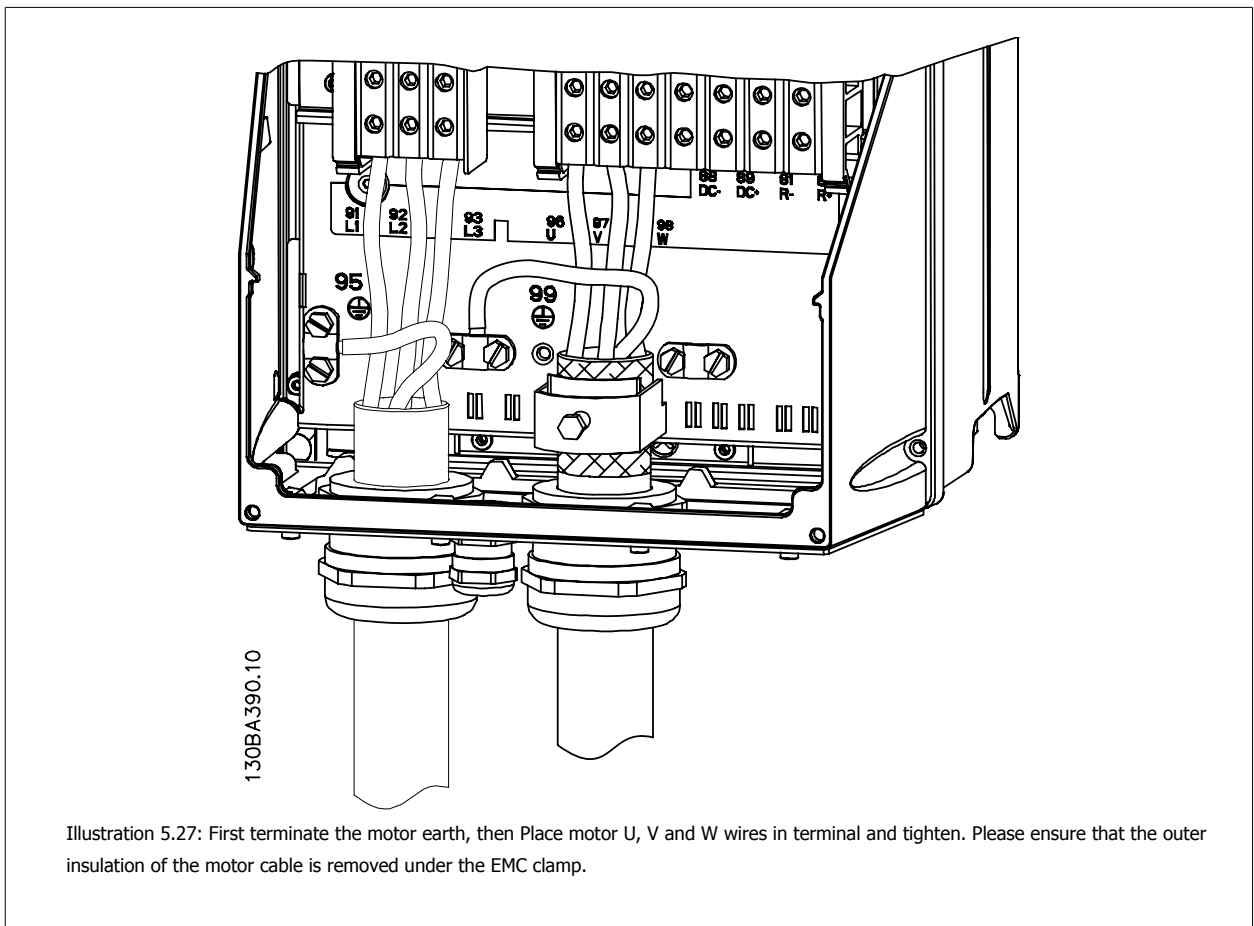


Illustration 5.27: First terminate the motor earth, then Place motor U, V and W wires in terminal and tighten. Please ensure that the outer insulation of the motor cable is removed under the EMC clamp.

### 5.1.18 Motor connection for C3 and C4

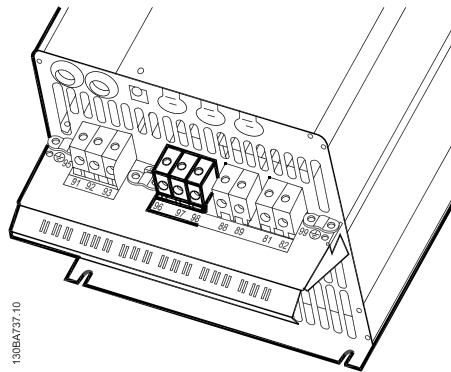


Illustration 5.28: First terminate the motor earth, then place motor U, V and W wires into the appropriate terminals and tighten. Please ensure that the outer insulation of the motor cable is removed under the EMC clamp.

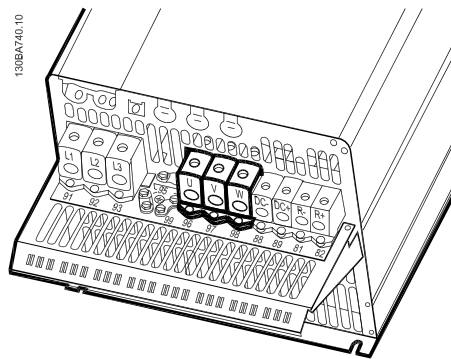


Illustration 5.29: First terminate the motor earth, then place motor U, V and W wires into the appropriate terminals and tighten. Please ensure that the outer insulation of the motor cable is removed under the EMC clamp.

### 5.1.19 DC bus connection

The DC bus terminal is used for DC back-up, with the intermediate circuit being supplied from an external source.

Terminal numbers used: 88, 89

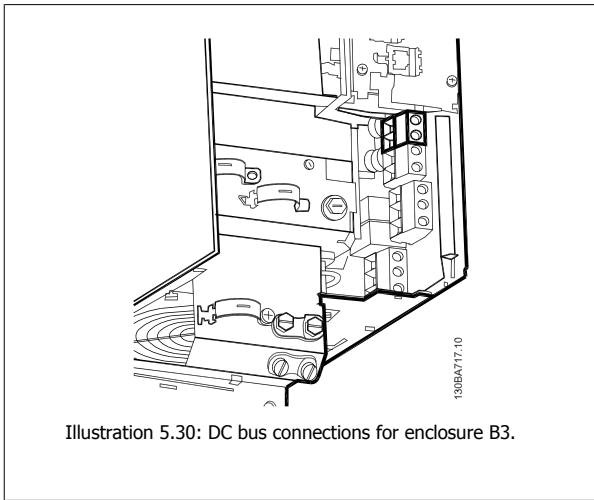


Illustration 5.30: DC bus connections for enclosure B3.

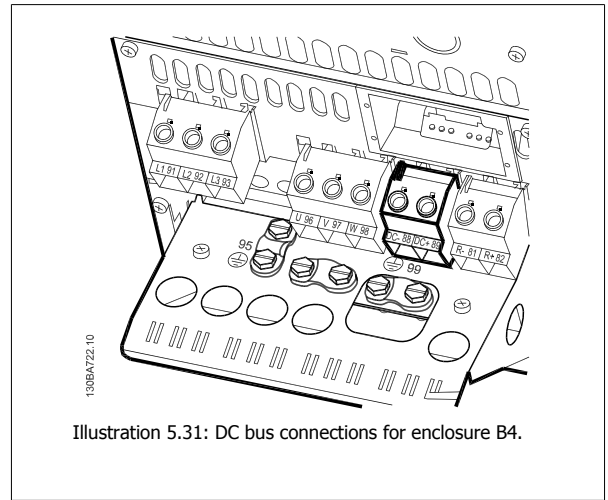


Illustration 5.31: DC bus connections for enclosure B4.

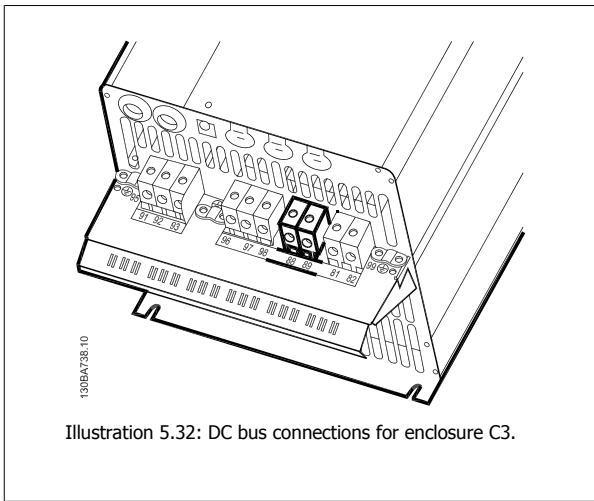


Illustration 5.32: DC bus connections for enclosure C3.

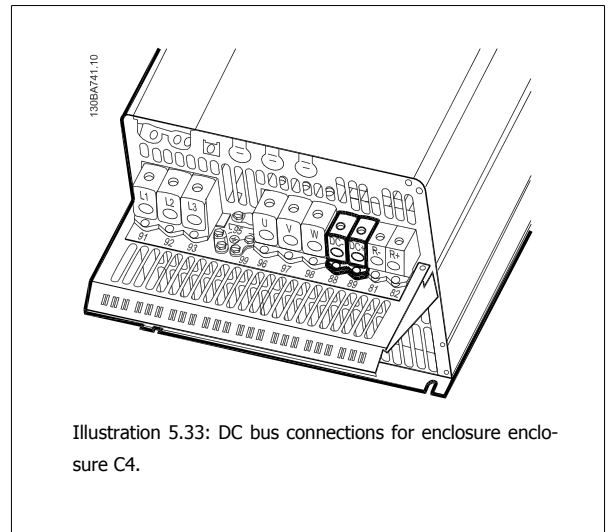



Illustration 5.33: DC bus connections for enclosure C4.

Please contact Danfoss if you require further information.


### 5.1.20 Brake Connection Option

The connection cable to the brake resistor must be screened/armoured.

Enclosure	A+B+C+D+F	A+B+C+D+F
Brake resistor	81	82
Terminals	R-	R+

 **NB!**  
Dynamic brake calls for extra equipment and safety considerations. For further information, please contact Danfoss.

1. Use cable clamps to connect the screen to the metal cabinet of the frequency converter and to the decoupling plate of the brake resistor.
2. Dimension the cross-section of the brake cable to match the brake current.

 **NB!**  
Voltages up to 975 V DC (@ 600 V AC) may occur between the terminals.

5

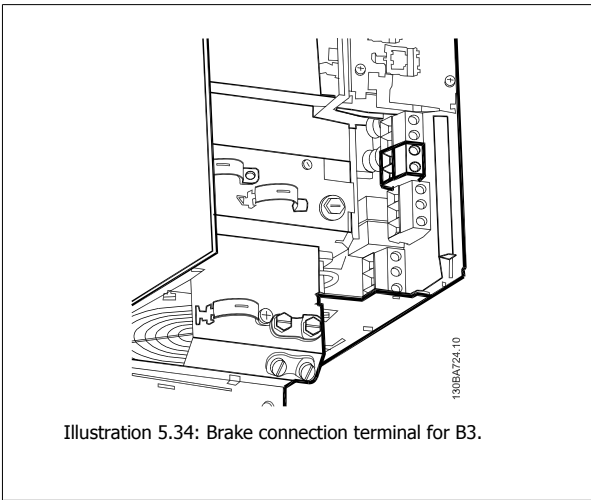


Illustration 5.34: Brake connection terminal for B3.

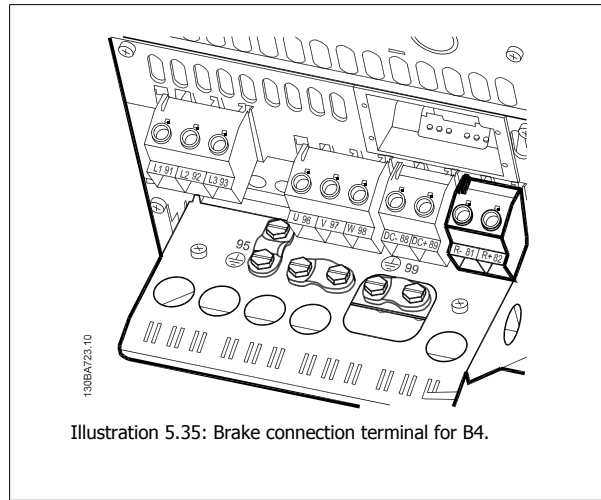


Illustration 5.35: Brake connection terminal for B4.

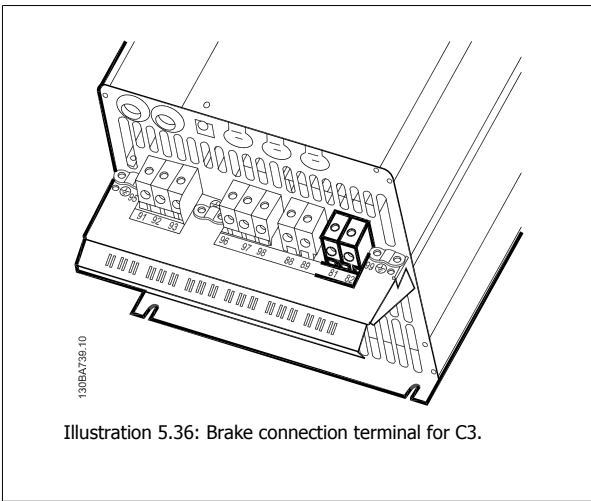


Illustration 5.36: Brake connection terminal for C3.

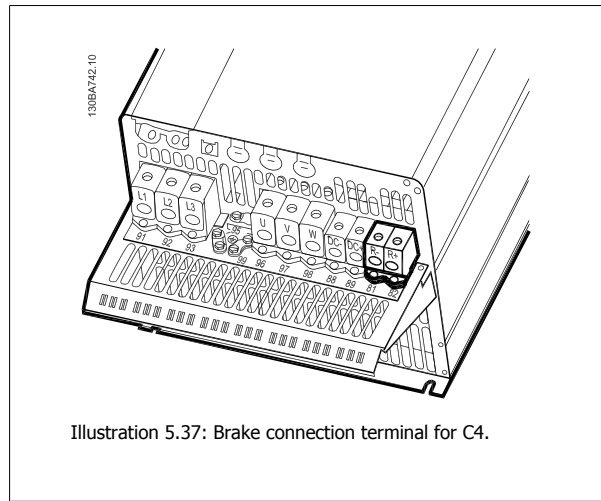


Illustration 5.37: Brake connection terminal for C4.



**NB!**

If a short circuit in the brake IGBT occurs, prevent power dissipation in the brake resistor by using a mains switch or contactor to disconnect the mains for the frequency converter. Only the frequency converter shall control the contactor.



**NB!**

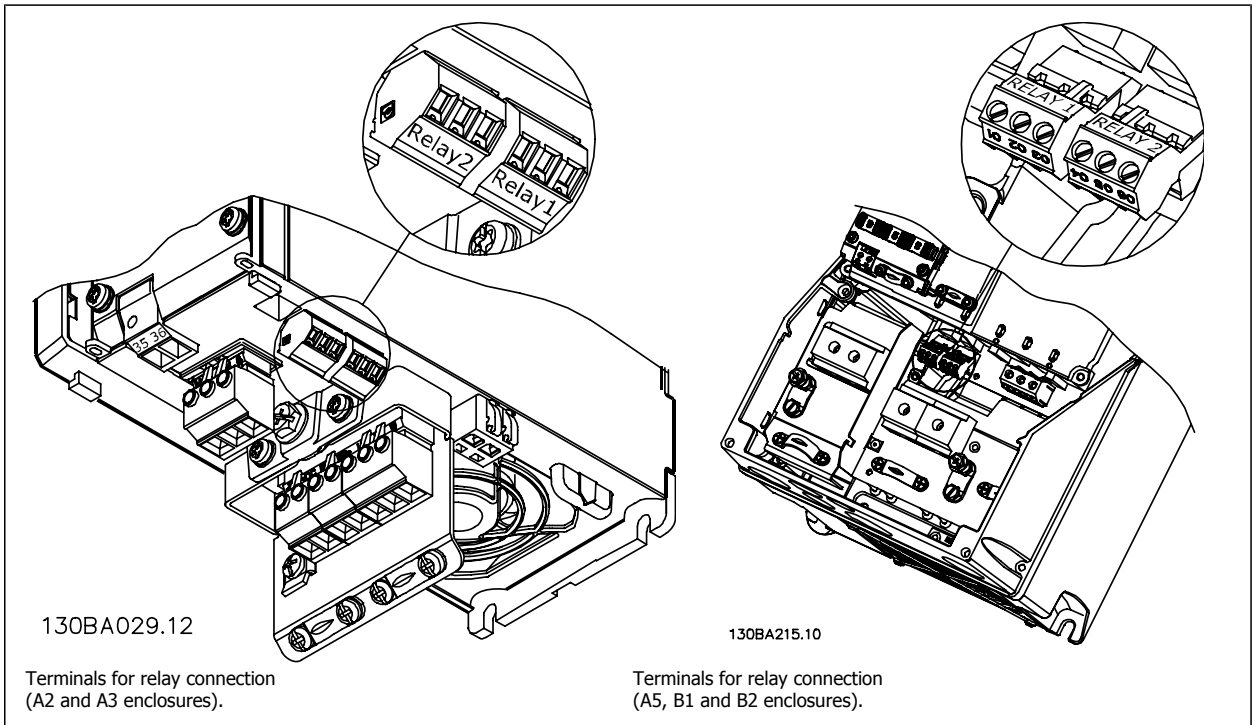
Place the brake resistor in an environment free of fire risk and ensure that no external objects can fall into the brake resistor through ventilation slots.  
Do not cover ventilation slots and grids.

**5.1.21 Relay Connection**

To set relay output, see par. group 5-4\* Relays.

No.	01 - 02	make (normally open)
	01 - 03	break (normally closed)
	04 - 05	make (normally open)
	04 - 06	break (normally closed)

**5**

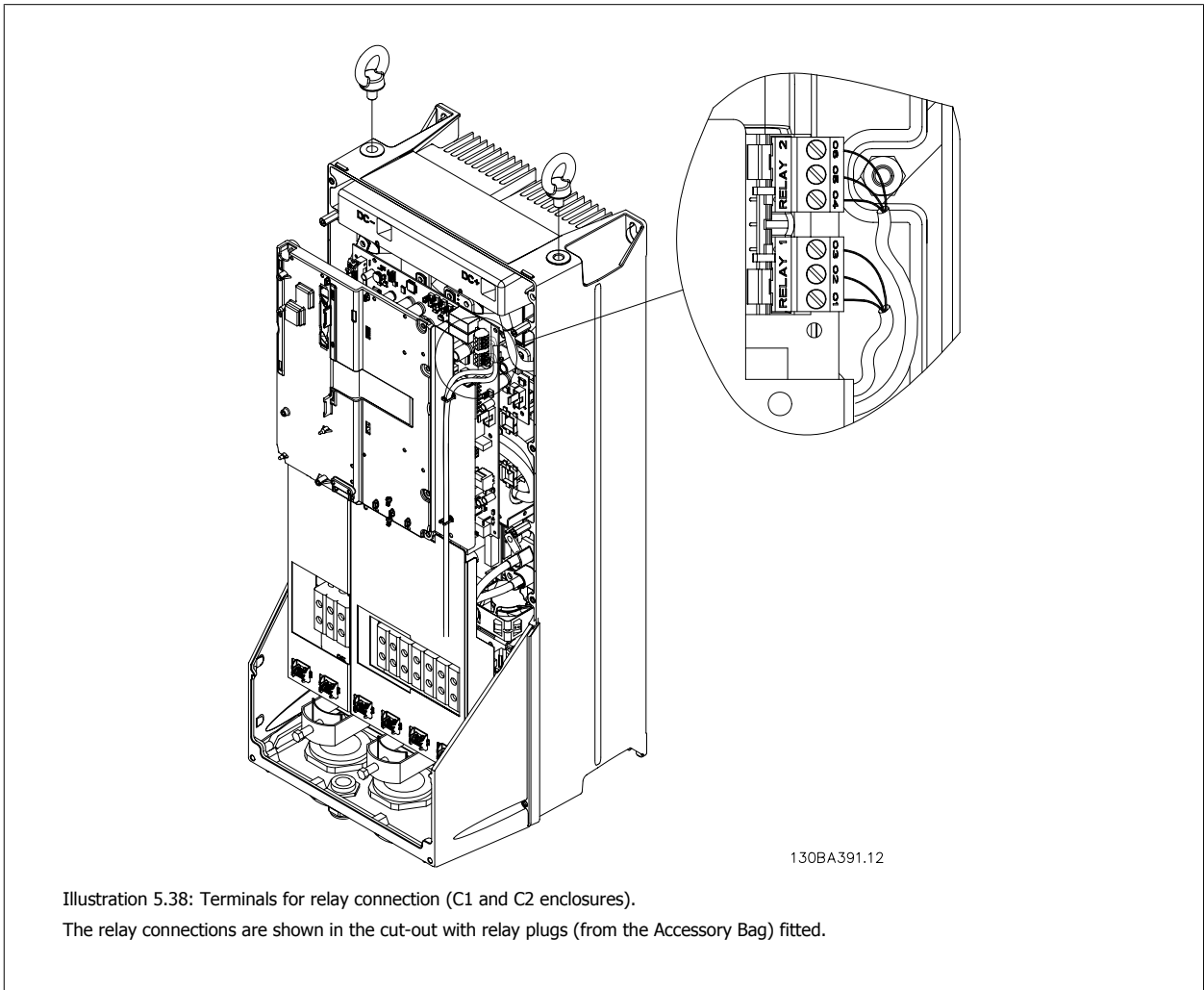


130BA029.12

Terminals for relay connection  
(A2 and A3 enclosures).

130BA215.10

Terminals for relay connection  
(A5, B1 and B2 enclosures).



130BA391.12

Illustration 5.38: Terminals for relay connection (C1 and C2 enclosures).  
The relay connections are shown in the cut-out with relay plugs (from the Accessory Bag) fitted.

5

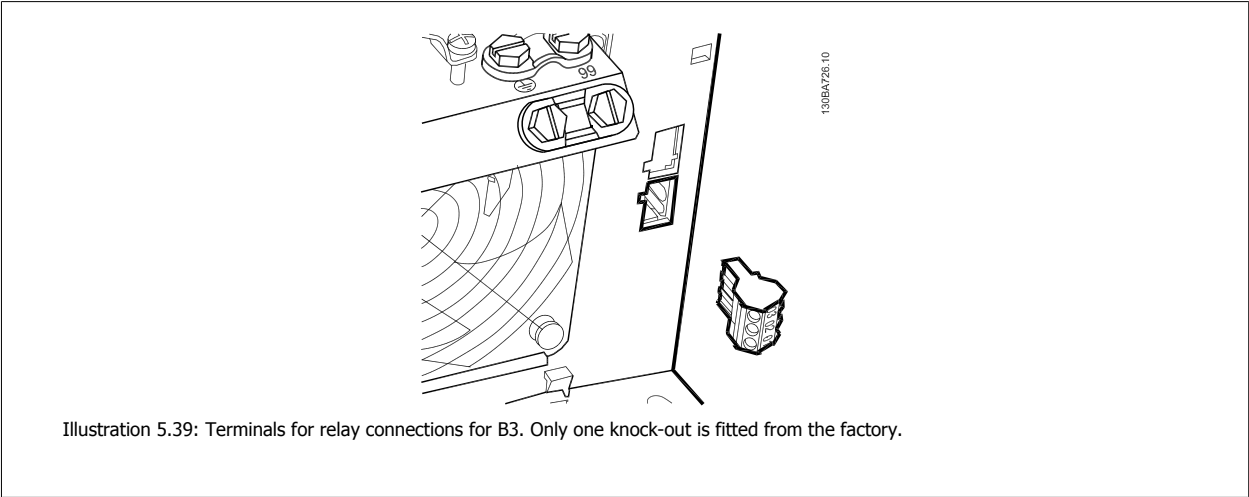


Illustration 5.39: Terminals for relay connections for B3. Only one knock-out is fitted from the factory.

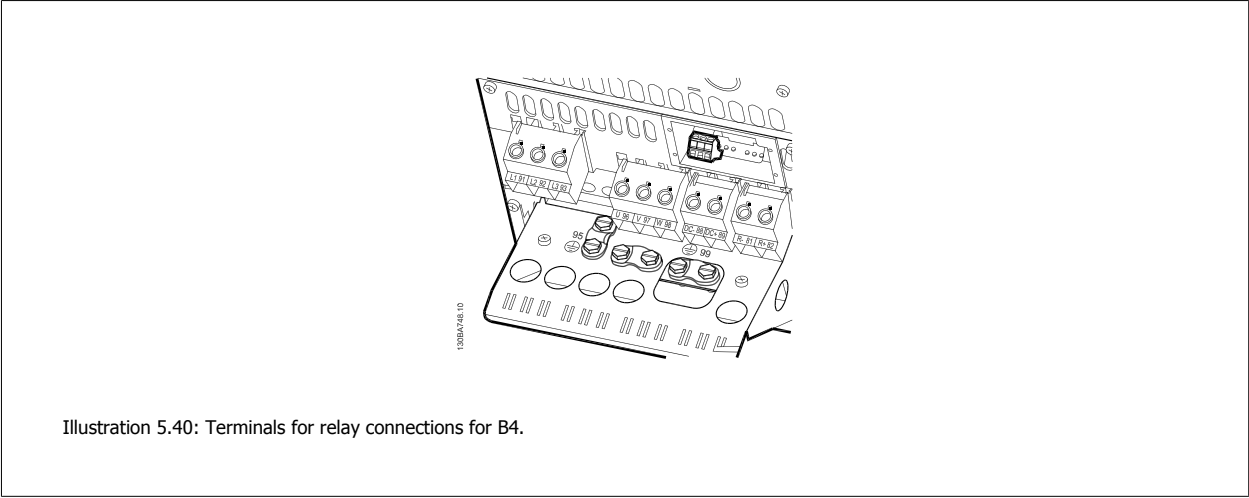


Illustration 5.40: Terminals for relay connections for B4.

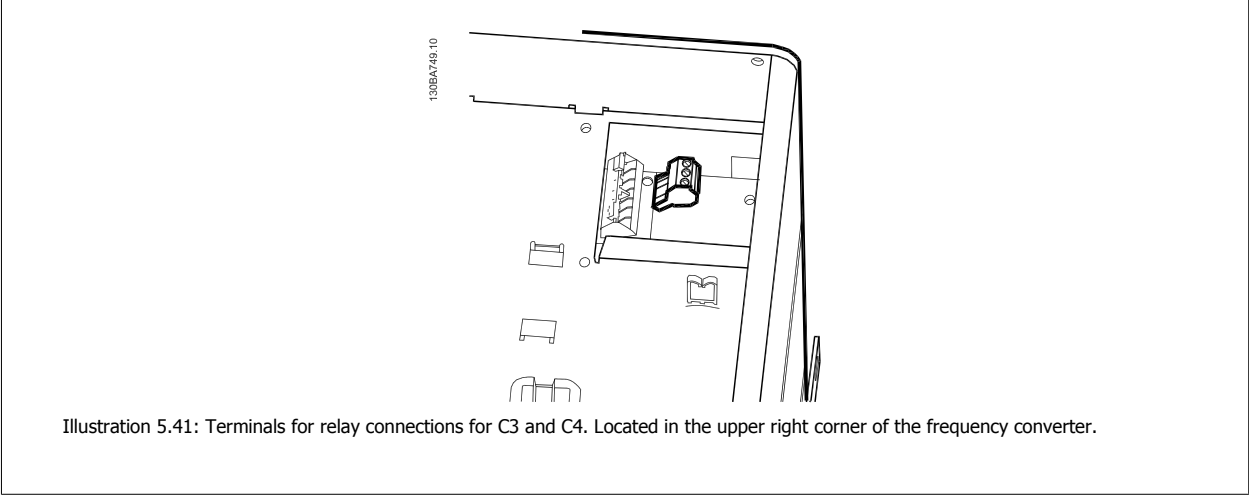


Illustration 5.41: Terminals for relay connections for C3 and C4. Located in the upper right corner of the frequency converter.



### 5.1.22 Relay Output

#### Relay 1

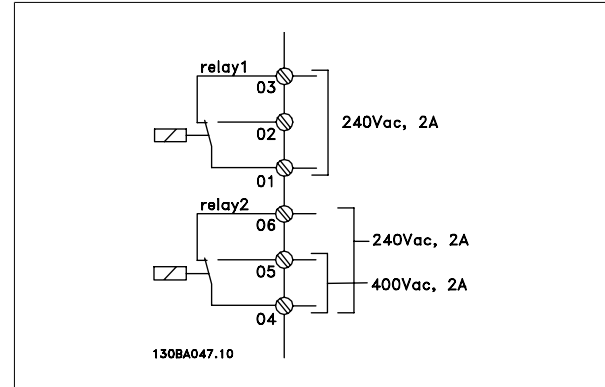
- Terminal 01: common
- Terminal 02: normal open 240 V AC
- Terminal 03: normal closed 240 V AC

#### Relay 2

- Terminal 04: common
- Terminal 05: normal open 400 V AC
- Terminal 06: normal closed 240 V AC

Relay 1 and relay 2 are programmed in par. 5-40 *Function Relay*, par. 5-41 *On Delay, Relay*, and par. 5-42 *Off Delay, Relay*.

Additional relay outputs by using option module MCB 105.



### 5.1.23 Wiring Example and Testing

The following section describes how to terminate control wires and how to access them. For an explanation of the function, programming and wiring of the control terminals, please see chapter, *How to programme the frequency converter*.

### 5.1.24 Access to Control Terminals

All terminals to the control cables are located underneath the terminal cover on the front of the frequency converter. Remove the terminal cover with a screwdriver.

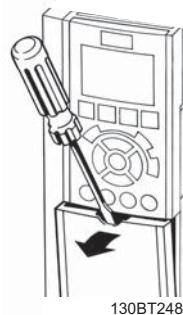


Illustration 5.42: Access to control terminals for A2, A3, B3, B4, C3 and C4 enclosures

Remove front-cover to access control terminals. When replacing the front-cover, please ensure proper fastening by applying a torque of 2 Nm.

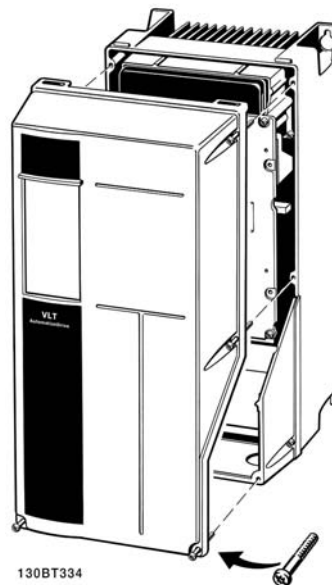
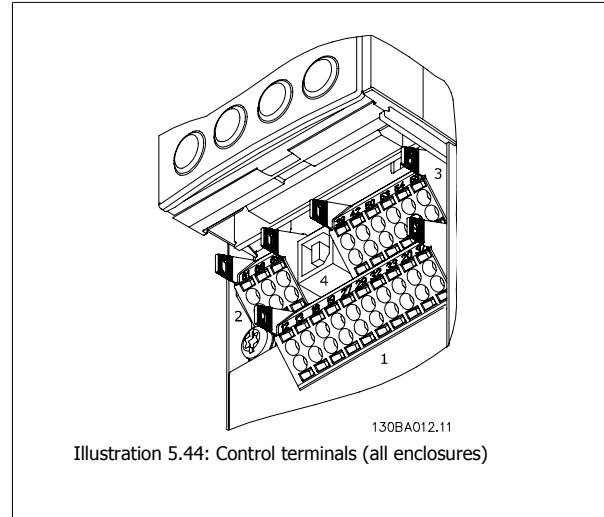


Illustration 5.43: Access to control terminals for A5, B1, B2, C1 and C2 enclosures

### 5.1.25 Control Terminals

**Drawing reference numbers:**

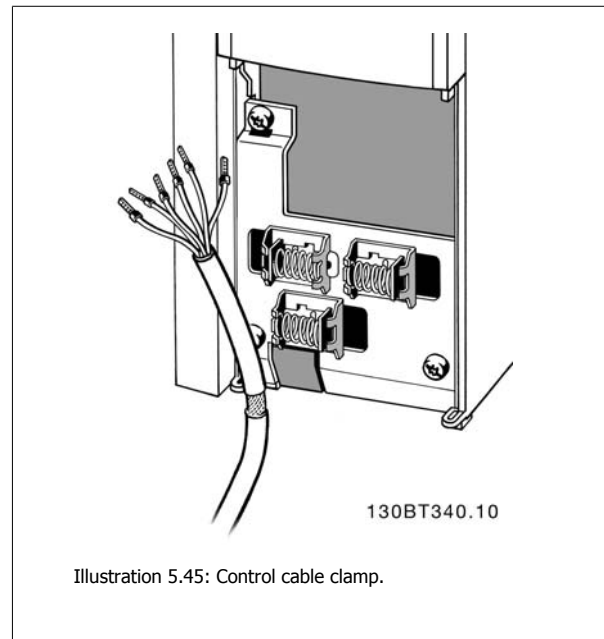
1. 10 pole plug digital I/O.
2. 3 pole plug RS-485 Bus.
3. 6 pole analog I/O.
4. USB connection.



### 5.1.26 Control Cable Clamp

1. Use a clamp from the accessory bag to connect screen to frequency converter decoupling plate for control cables.

See section entitled *Earthing of Screened/Armoured Control Cables* for the correct termination of control cables.



5.1.27 Electrical Installation and Control Cables

5

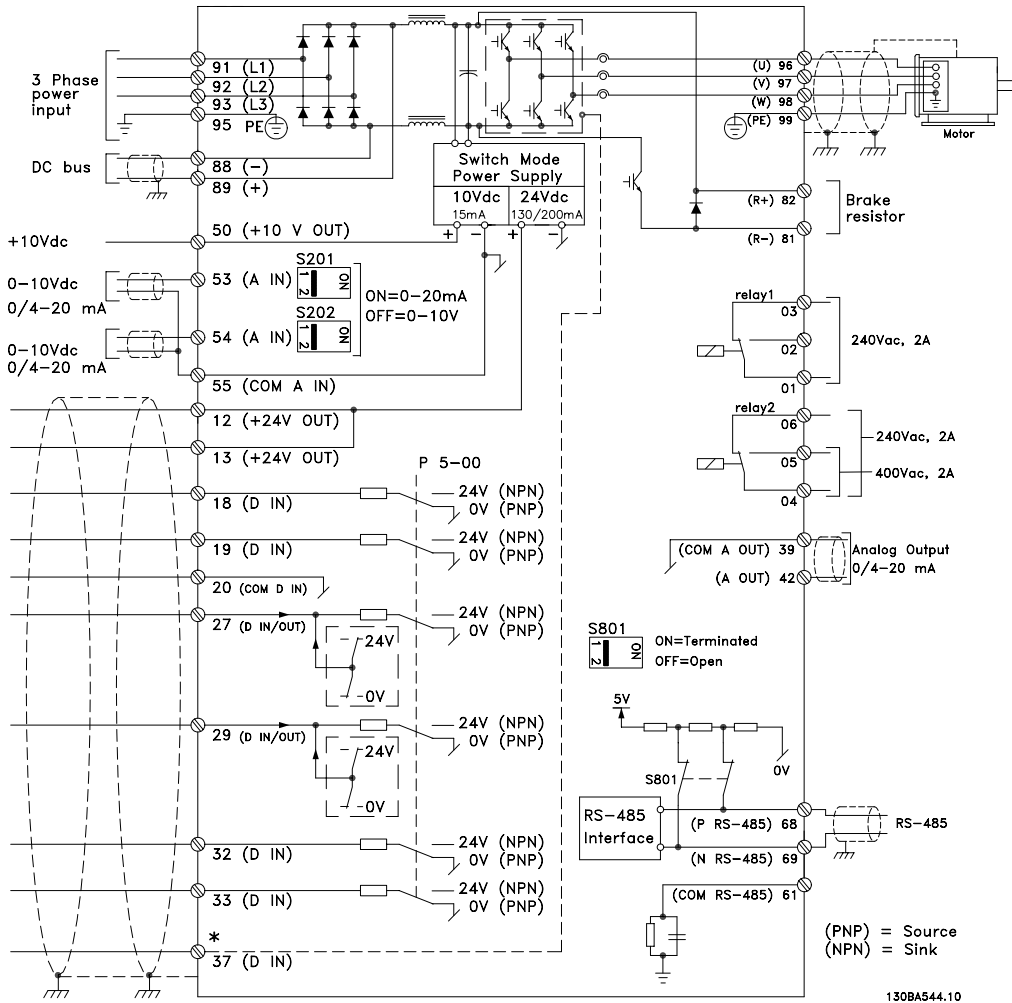



Illustration 5.46: Diagram showing all electrical terminals. (Terminal 37 present for units with Safe Stop Function only.)

Terminal number	Terminal description	Parameter number	Factory default
1+2+3	Terminal 1+2+3-Relay1	5-40	No operation
4+5+6	Terminal 4+5+6-Relay2	5-40	No operation
12	Terminal 12 Supply	-	+24 VDC
13	Terminal 13 Supply	-	+24 VDC
18	Terminal 18 Digital Input	5-10	Start
19	Terminal 19 Digital Input	5-11	No operation
20	Terminal 20	-	Common
27	Terminal 27 Digital Input/Output	5-12/5-30	Coast inverse
29	Terminal 29 Digital Input/Output	5-13/5-31	Jog
32	Terminal 32 Digital Input	5-14	No operation
33	Terminal 33 Digital Input	5-15	No operation
37	Terminal 37 Digital Input	-	Safe Stop
42	Terminal 42 Analog Output	6-50	No operation
53	Terminal 53 Analog Input	3-15/6-1*/20-0*	Reference
54	Terminal 54 Analog Input	3-15/6-2*/20-0*	Feedback

Table 5.8: Terminal connections

Very long control cables and analog signals may, in rare cases and depending on installation, result in 50/60 Hz earth loops due to noise from mains supply cables.

If this occurs, break the screen or insert a 100 nF capacitor between screen and chassis.




**NB!**  
The common of digital / analog inputs and outputs should be connected to separate common terminals 20, 39, and 55. This will avoid ground current interference among groups. For example, it avoids switching on digital inputs disturbing analog inputs.



**NB!**  
Control cables must be screened/armoured.

### 5.1.28 How to Test Motor and Direction of Rotation.



Note that unintended motor start can occur, ensure no personnel or equipment is in danger!

Please follow these steps to test the motor connection and direction of rotation. Start with no power to the unit.

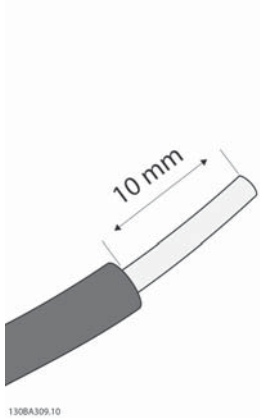


Illustration 5.47:  
**Step 1:** First remove the insulation on both ends of a 50 to 70 mm piece of wire.

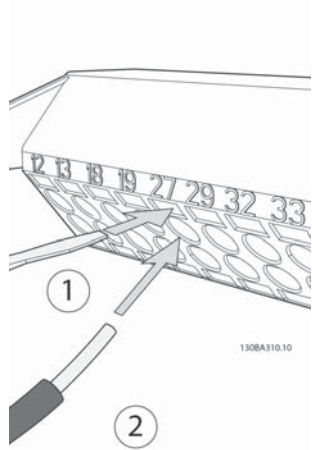


Illustration 5.48:  
**Step 2:** Insert one end in terminal 27 using a suitable terminal screwdriver. (Note: For units with Safe Stop function, the existing jumper between terminal 12 and 37 should not be removed for the unit to be able to run!)

5

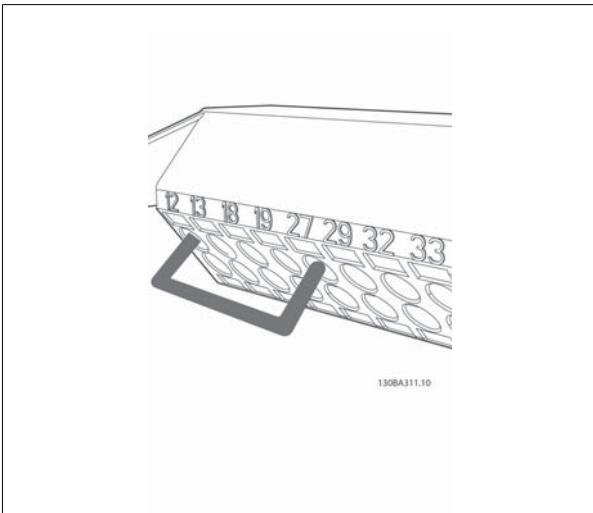


Illustration 5.49:

**Step 3:** Insert the other end in terminal 12 or 13. (Note: For units with Safe Stop function, the existing jumper between terminal 12 and 37 should not be removed for the unit to be able to run!)

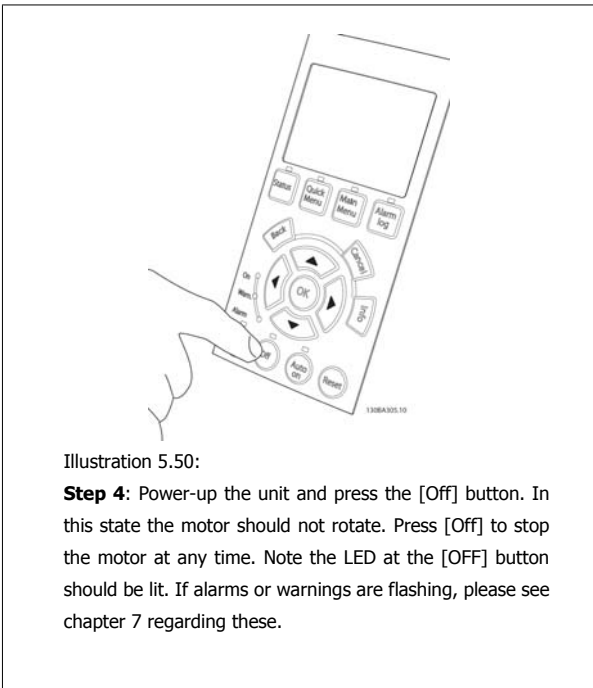


Illustration 5.50:

**Step 4:** Power-up the unit and press the [Off] button. In this state the motor should not rotate. Press [Off] to stop the motor at any time. Note the LED at the [OFF] button should be lit. If alarms or warnings are flashing, please see chapter 7 regarding these.



Illustration 5.51:

**Step 5:** By pressing the [Hand on] button, the LED above the button should be lit and the motor may rotate.



Illustration 5.52:

**Step 6:** The speed of the motor can be seen in the LCP. It can be adjusted by pushing the up ▲ and down ▼ arrow buttons.

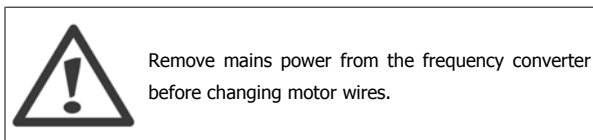
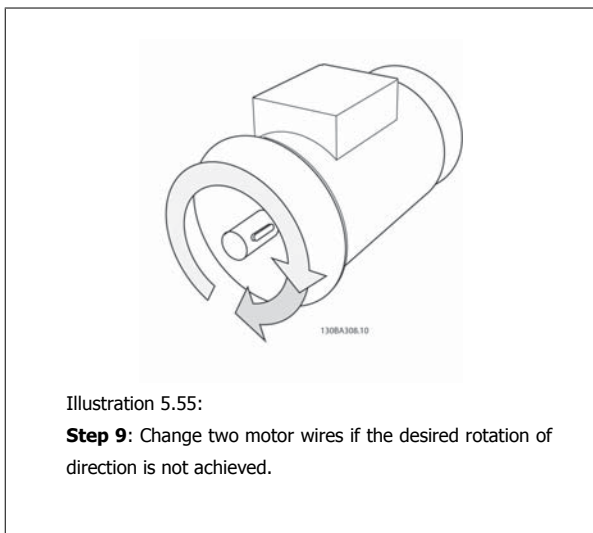


Illustration 5.53:

**Step 7:** To move the cursor, use the left ◀ and right ▶ arrow buttons. This enables changing the speed in larger increments.



5



### 5.1.29 Switches S201, S202, and S801

Switches S201 (AI 53) and S202 (AI 54) are used to select a current (0-20 mA) or a voltage (0 to 10 V) configuration of the analog input terminals 53 and 54 respectively.

Switch S801 (BUS TER.) can be used to enable termination on the RS-485 port (terminals 68 and 69).

Please note that the switches may be covered by an option, if fitted.

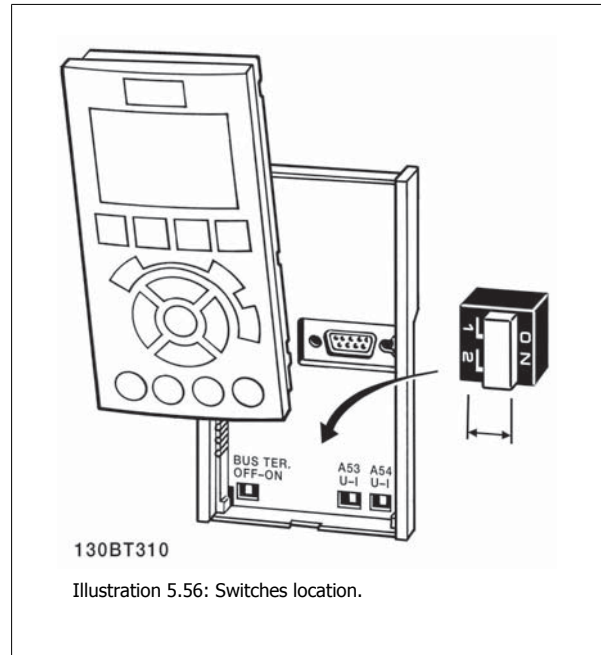
**Default setting:**

S201 (AI 53) = OFF (voltage input)

S202 (AI 54) = OFF (voltage input)

S801 (Bus termination) = OFF

5



## 5.2 Final optimization and test

### 5.2.1 Final optimization and test

To optimize motor shaft performance and optimize the frequency converter for the connected motor and installation, please follow these steps. Ensure that frequency converter and motor are connected, and power is applied to frequency converter.



**NB!**

Before power up ensure that connected equipment is ready for use.

**Step 1. Locate motor name plate.**



**NB!**

The motor is either star- (Y) or delta- connected ( $\Delta$ ). This information is located on the motor name plate data.



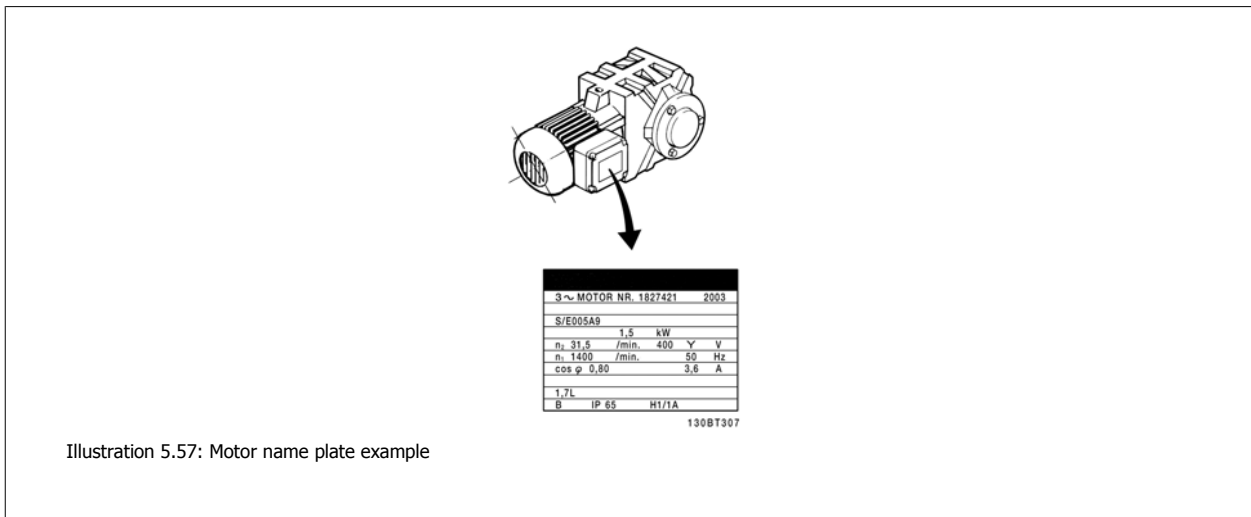


Illustration 5.57: Motor name plate example

5

**Step 2. Enter motor name plate data in following parameter list.**

To access list first press [QUICK MENU] key then select "Q2 Quick Setup".

1.	Motor Power [kW] or Motor Power [HP]	par. 1-20 par. 1-21
2.	Motor Voltage	par. 1-22
3.	Motor Frequency	par. 1-23
4.	Motor Current	par. 1-24
5.	Motor Nominal Speed	par. 1-25

Table 5.9: Motor related parameters

**Step 3. Activate Automatic Motor Adaptation (AMA)**

Performing AMA ensures best possible performance. AMA automatically takes measurements from the specific motor connected and compensates for installation variances.

1. Connect terminal 27 to terminal 12 or use [MAIN MENU] and set Terminal 27 par. 5-12 to *No operation* (par. 5-12 [0])
2. Press [QUICK MENU], select "Q2 Quick Setup", scroll down to AMA par. 1-29.
3. Press [OK] to activate the AMA par. 1-29.
4. Choose between complete or reduced AMA. If sine wave filter is mounted, run only reduced AMA, or remove sine wave filter during AMA procedure.
5. Press [OK] key. Display should show "Press [Hand on] to start".
6. Press [Hand on] key. A progress bar indicates if AMA is in progress.

## 5

**Stop the AMA during operation**

1. Press the [OFF] key - the frequency converter enters into alarm mode and the display shows that the AMA was terminated by the user.

**Successful AMA**

1. The display shows "Press [OK] to finish AMA".
2. Press the [OK] key to exit the AMA state.

**Unsuccessful AMA**

1. The frequency converter enters into alarm mode. A description of the alarm can be found in the *Troubleshooting* section.
2. "Report Value" in the [Alarm Log] shows the last measuring sequence carried out by the AMA, before the frequency converter entered alarm mode. This number along with the description of the alarm will assist troubleshooting. If contacting Danfoss Service, make sure to mention number and alarm description.

**NB!**

Unsuccessful AMA is often caused by incorrectly entered motor name plate data or too big difference between the motor power size and the frequency converter power size.

**Step 4. Set speed limit and ramp time**

Set up the desired limits for speed and ramp time.

Minimum Reference	par. 3-02
Maximum Reference	par. 3-03

Motor Speed Low Limit	par. 4-11 or 4-12
Motor Speed High Limit	par. 4-13 or 4-14

Ramp 1 Ramp Up Time [s]	par. 3-41
Ramp 1 Ramp Down Time 1 [s]	par. 3-42

## 6 Application Examples

### 6.1.1 Start/Stop

Terminal 18 = start/stop par. 5-10 [8] *Start*

Terminal 27 = No operation par. 5-12 [0] *No operation* (Default *coast inverse*)

Par. 5-10 *Digital Input*, Terminal 18 = *Start* (default)

Par. 5-12 *Digital Input*, Terminal 27 = *coast inverse* (default)

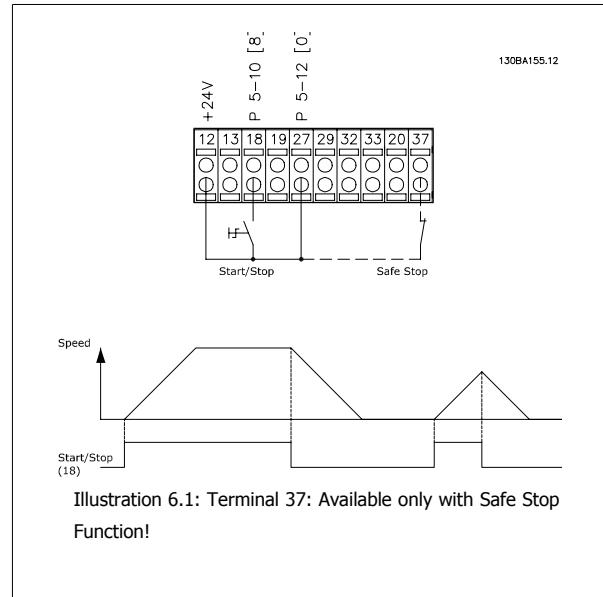


Illustration 6.1: Terminal 37: Available only with Safe Stop Function!

### 6.1.2 Closed Loop Wiring

Terminal 12 /13: +24V DC

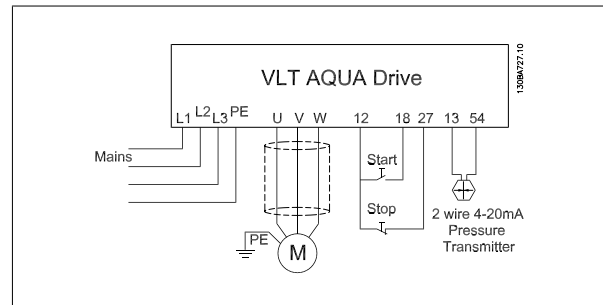
Terminal 18: Start par. 5-18 [8] Start (Default)

Terminal 27: Coast par. 5-12 [2] coast inverse (Default)

Terminal 54: Analog input

L1-L3: Mains terminals

U,V and W: Motor terminals



### 6.1.3 Submersible Pump Application

The system consists of a submersible pump controlled by a Danfoss VLT AQUA Drive and a pressure transmitter. The transmitter gives a 4-20 mA feedback signal to the VLT AQUA Drive, which keeps a constant pressure by controlling the speed of the pump. To design a drive for a submersible pump application, there are a few important issues to take into consideration. Therefore the drive used must be chosen according to motor current.

1. The motor is a so called "Can motor" with a stainless steel can between the rotor and stator. There is a larger and a more magnetic resistant air-gap than on a normal motor hence a weaker field which results in the motors being designed with a higher rated current than a norm motor with similar rated power.
2. The pump contains thrust bearings which will be damaged when running below minimum speed which normally will be 30 Hz.
3. The motor reactance is nonlinear in submersible pump motors and therefore Automatic Motor Adaption (AMA) may not be possible. However, normally submersible pumps are operated with very long motor cables that might eliminate the nonlinear motor reactance and enable the drive to perform AMA. If AMA fails, the motor data can be set from parameter group 1-3\* (see motor datasheet). Be aware that if AMA has succeeded the drive will compensate for voltage drop in the long motor cables, so if the Advanced motor data are set manually, the length of the motor cable must be taken into considerations to optimize system performance.
4. It is important that the system is operated with a minimum of wear and tear of the pump and motor. A Danfoss Sine-Wave filter can lower the motor insulation stress and increase lifetime (check actual motor insulation and the frequency converter du/dt specification). It is recommended to use a filter to reduce the need for service.
5. EMC performance can be difficult to achieve due to the fact that the special pump cable which is able to withstand the wet conditions in the well normally is unshielded. A solution could be to use a screened cable above the well and fix the screen to the well pipe if it is made of steel (can also be made of plastic). A Sine-Wave filter will also reduce the EMI from unshielded motor cables.

The special "can motor" is used due to the wet installation conditions. The drive needs to be designed for the system according to output current to be able to run the motor at nominal power.

To prevent damage to the thrust bearings of the pump, it is important to ramp the pump from stop to min. speed as quick as possible. Well-known manufacturers of submersible pumps recommend that the pump is ramped to min. speed (30 Hz) in max. 2 -3 seconds. The new VLT® AQUA Drive is designed with initial and final Ramp for these applications. The initial and final ramps are 2 individual ramps, where Initial Ramp, if enabled, will ramp the motor from stop to min. speed and automatically switch to normal ramp, when min. speed is reached. Final ramp will do the opposite from min. speed to stop in a stop situation.

Pipe-Fill mode can be enabled to prevent water hammering. The Danfoss frequency converter is capable of filling vertical pipes using the PID controller to slowly ramp up the pressure with a user specified rate (units/sec). If enabled the drive will, when it reaches min. speed after startup, enter pipe fill mode. The pressure will slowly be ramped up until it reaches a user specified Filled Set Point, where after the drive automatically disables Pipe Fill Mode and continues in normal closed loop operation.

This feature is designed for irrigation applications.

#### Electrical Wiring

##### Typical parameter settings

Typical/recommended settings in brackets().

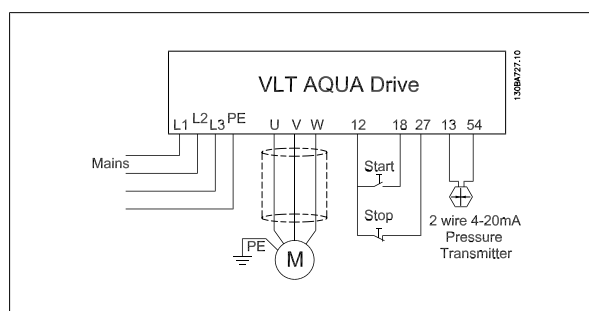
##### Parameters:

Motor Rated Power	Par. 1-20 / par. 1-21
Motor Rated Voltage	Par. 1-22
Motor Current	Par. 1-24
Motor Rated Speed	Par. 1-28
Enable Reduced Automatic Motor Adaptation (AMA in par. 1-29)	



##### NB!

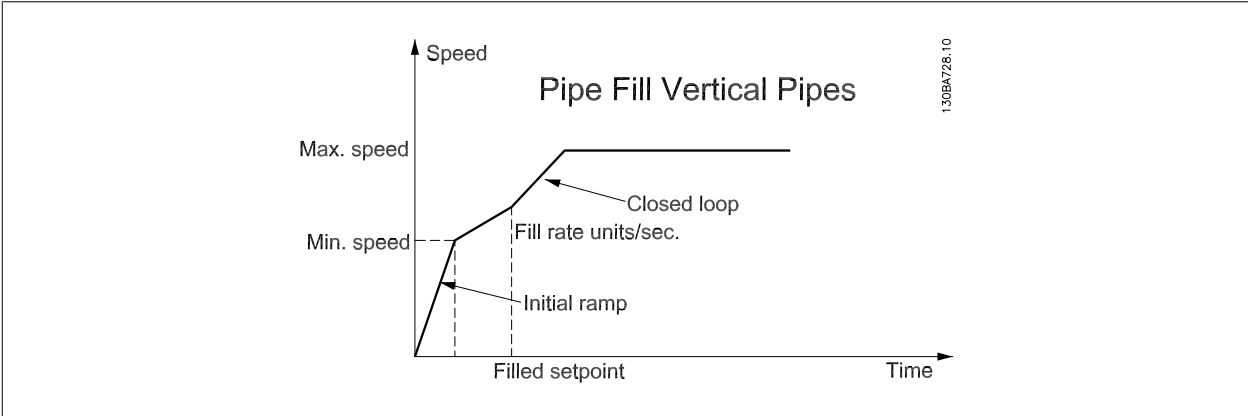
Note the analog input 2, (terminal (54) format must be set to mA. (switch 202).



Min. Reference	Par. 3-01	(30 Hz)
Max. Reference	Par. 3-02	(50/60 Hz)
Initial Ramp Up Time	Par. 3-84	(2 sec.)
Final Ramp Down Time	Par. 3-88	(2 sec.)
Normal Ramp Up Time	Par. 3-41	(8 sec. depending on size)
Normal Ramp Down Time	Par. 3-42	(8 sec. depending on size)
Motor Min. Speed	Par. 4-11	(30 Hz)
Motor Max. Speed	Par. 4-13	(50/60 Hz)

Use the "Closed Loop" wizard under "Quick Menu\_Funtion\_Setup", to easily set up the feedback settings in the PID controller.

<b>Pipe Fill Mode</b>		
Pipe Fill Enable	Par. 29-00	
Pipe Fill Rate	Par. 29-04	(Feedback units/sec.)
Filled Set Point	Par. 29-05	(Feedback units)





## 7 How to operate the frequency converter

### 7.1 Ways of Operation

#### 7.1.1 Ways of Operation

The frequency converter can be operated in 3 ways:

1. Graphical Local Control Panel (GLCP), see 6.1.2
2. Numeric Local Control Panel (NLCP), see 6.1.3
3. RS-485 serial communication or USB, both for PC connection, see 6.1.4

If the frequency converter is fitted with fieldbus option, please refer to relevant documentation.

#### 7.1.2 How to operate graphical LCP (GLCP)

The following instructions are valid for the GLCP (LCP 102).

The GLCP is divided into four functional groups:

1. Graphical display with Status lines.
2. Menu keys and indicator lights (LED's) - selecting mode, changing parameters and switching between display functions.
3. Navigation keys and indicator lights (LEDs).
4. Operation keys and indicator lights (LEDs).

#### Graphical display:

The LCD-display is back-lit with a total of 6 alpha-numeric lines. All data is displayed on the LCP which can show up to five operating variables while in [Status] mode.

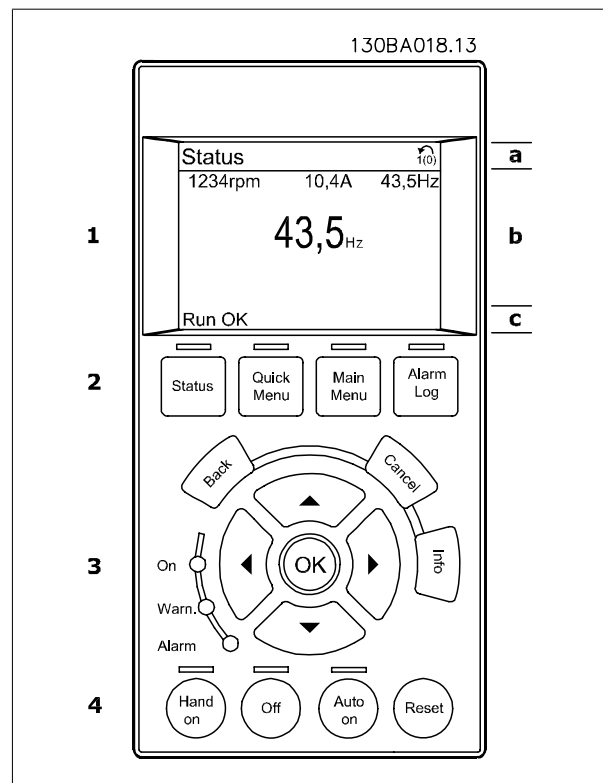
#### Display lines:

- a. **Status line:** Status messages displaying icons and graphics.
- b. **Line 1-2:** Operator data lines displaying data and variables defined or chosen by the user. By pressing the [Status] key, up to one extra line can be added.
- c. **Status line:** Status messages displaying text.

The display is divided into 3 sections:

#### Top section (a)

shows the status when in status mode or up to 2 variables when not in status mode and in the case of Alarm/Warning.



The number of the Active Set-up (selected as the Active Set-up in par. 0-10) is shown. When programming in another Set-up than the Active Set-up, the number of the Set-up being programmed appears to the right in brackets.

**Middle section (b)**

shows up to 5 variables with related unit, regardless of status. In case of alarm/warning, the warning is shown instead of the variables.

It is possible to toggle between three status read-out displays by pressing the [Status] key.

Operating variables with different formatting are shown in each status screen - see below.

Several values or measurements can be linked to each of the displayed operating variables. The values / measurements to be displayed can be defined via par. 0-20, 0-21, 0-22, 0-23, and 0-24, which can be accessed via [QUICK MENU], "Q3 Function Setups", "Q3-1 General Settings", "Q3-11 Display Settings".

Each value / measurement readout parameter selected in par. 0-20 to par. 0-24 has its own scale and number of digits after a possible decimal point. Larger numeric values are displayed with few digits after the decimal point.

Ex.: Current readout

5.25 A; 15.2 A 105 A.

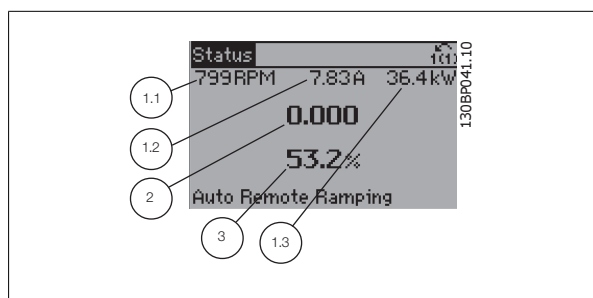
7

**Status display I**

This read-out state is standard after start-up or initialization.

Use [INFO] to obtain information about the value/measurement linked to the displayed operating variables (1.1, 1.2, 1.3, 2, and 3).

See the operating variables shown in the display in this illustration. 1.1, 1.2 and 1.3 are shown in small size. 2 and 3 are shown in medium size.

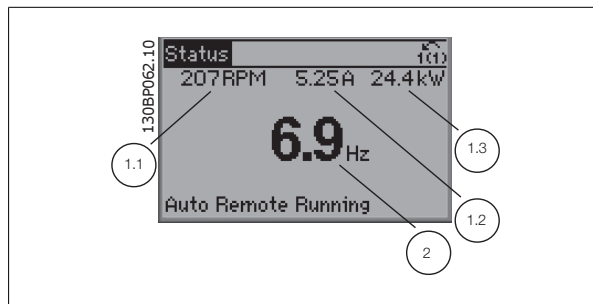


**Status display II**

See the operating variables (1.1, 1.2, 1.3, and 2) shown in the display in this illustration.

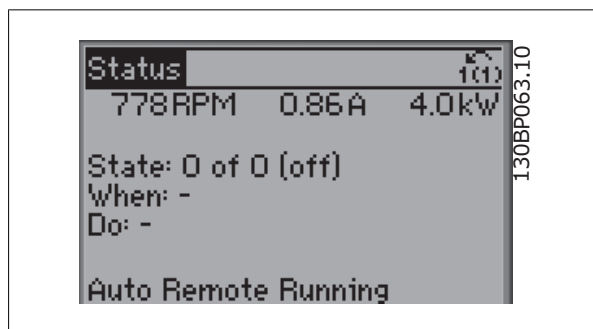
In the example, Speed, Motor current, Motor power and Frequency are selected as variables in the first and second lines.

1.1, 1.2 and 1.3 are shown in small size. 2 is shown in large size.



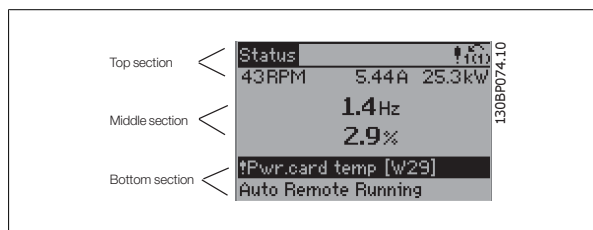
**Status display III:**

This state displays the event and action of the Smart Logic Control. For further information, see section *Smart Logic Control*.



**Bottom section**

always shows the state of the frequency converter in Status mode.





**Display Contrast Adjustment**

Press [status] and [▲] for darker display

Press [status] and [▼] for brighter display

**Indicator lights (LEDs):**

If certain threshold values are exceeded, the alarm and/or warning LED lights up. A status and alarm text appear on the control panel.

The On LED is activated when the frequency converter receives power from mains voltage, a DC bus terminal, or an external 24 V supply. At the same time, the back light is on.

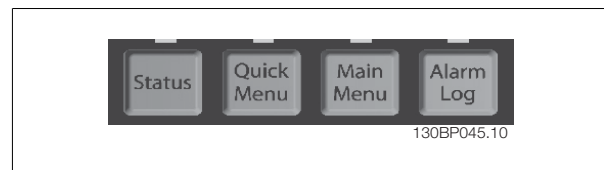
- Green LED/On: Control section is working.
- Yellow LED/Warn.: Indicates a warning.
- Flashing Red LED/Alarm: Indicates an alarm.



**GLCP keys**

**Menu keys**

The menu keys are divided into functions. The keys below the display and indicator lamps are used for parameter set-up, including choice of display indication during normal operation.



**[Status]**

Indicates the status of the frequency converter and/or the motor. 3 different readouts can be chosen by pressing the [Status] key:

5 line readouts, 4 line readouts or Smart Logic Control.

Use [Status] for selecting the mode of display or for changing back to Display mode from either the Quick Menu mode, the Main Menu mode or Alarm mode. Also use the [Status] key to toggle single or double read-out mode.

**[Quick Menu]**

Allows quick set-up of the frequency converter. **The most common functions can be programmed here.**

**The [Quick Menu] consists of:**

- **Q1: My Personal Menu**
- **Q2: Quick Setup**
- **Q3: Function Setups**
- **Q5: Changes Made**
- **Q6: Loggings**

The Function set-up provides quick and easy access to all parameters required for the majority of water and wastewater applications including variable torque, constant torque, pumps, dosing pumps, well pumps, booster pumps, mixer pumps, aeration blowers and other pump and fan applications. Amongst other features it also includes parameters for selecting which variables to display on the LCP, digital preset speeds, scaling of analog references, closed loop single zone and multi-zone applications and specific functions related to water and wastewater applications.

The Quick Menu parameters can be accessed immediately unless a password has been created via par. 0-60, 0-61, 0-65 or 0-66.

It is possible to switch directly between Quick Menu mode and Main Menu mode.

**[Main Menu]**

is used for programming all parameters.

The Main Menu parameters can be accessed immediately unless a password has been created via par. 0-60, 0-61, 0-65 or 0-66. For the majority of water and wastewater applications it is not necessary to access the Main Menu parameters but instead the Quick Menu, Quick Setup and Function Setups provides the simplest and quickest access to the typical required parameters.

It is possible to switch directly between Main Menu mode and Quick Menu mode.

Parameter shortcut can be carried out by pressing down the [Main Menu] key for 3 seconds. The parameter shortcut allows direct access to any parameter.

**[Alarm Log]**

displays an Alarm list of the five latest alarms (numbered A1-A5). To obtain additional details about an alarm, use the arrow keys to manoeuvre to the alarm number and press [OK]. Information is displayed about the condition of the frequency converter before it enters the alarm mode.

**[Back]**

reverts to the previous step or layer in the navigation structure.

**[Cancel]**

last change or command will be cancelled as long as the display has not been changed.

**[Info]**

displays information about a command, parameter, or function in any display window. [Info] provides detailed information when needed.

Exit Info mode by pressing either [Info], [Back], or [Cancel].



## 7

**Navigation Keys**

The four navigation arrows are used to navigate between the different choices available in [Quick Menu], [Main Menu] and [Alarm Log]. Use the keys to move the cursor.

**[OK]**

is used for choosing a parameter marked by the cursor and for enabling the change of a parameter.

**Operation Keys**


for local control are found at the bottom of the control panel.

**[Hand On]**

enables control of the frequency converter via the GLCP. [Hand on] also starts the motor, and it is now possible to give the motor speed reference by means of the arrow keys. The key can be *Enabled* [1] or *Disabled* [0] via par. 0-40 [Hand on] Key on LCP.

**The following control signals will still be active when [Hand on] is activated:**

- [Hand on] - [Off] - [Auto on]
- Reset
- Coasting stop inverse (motor coasting to stop)
- Reversing
- Set-up select lsb - Set-up select msb
- Stop command from serial communication
- Quick stop
- DC brake




**NB!**  
External stop signals activated by means of control signals or a serial bus will override a "start" command via the LCP.

**[Off]**

stops the connected motor. The key can be *Enabled* [1] or *Disabled* [0] via par. 0-41 [Off] key on LCP. If no external stop function is selected and the [Off] key is inactive the motor can only be stopped by disconnecting the mains supply.

**[Auto On]**

enables the frequency converter to be controlled via the control terminals and/or serial communication. When a start signal is applied on the control terminals and/or the bus, the frequency converter will start. The key can be *Enabled* [1] or *Disabled* [0] via par. 0-42 [Auto on] key on LCP.



**NB!**  
An active HAND-OFF-AUTO signal via the digital inputs has higher priority than the control keys [Hand on] – [Auto on].

**[Reset]**

is used for resetting the frequency converter after an alarm (trip). The key can be *Enabled* [1] or *Disabled* [0] via par. 0-43 Reset Keys on LCP.

**The parameter shortcut**

can be carried out by holding down the [Main Menu] key for 3 seconds. The parameter shortcut allows direct access to any parameter.

### 7.1.3 How to operate numeric LCP (NLCP)

The following instructions are valid for the NLCP (LCP 101).

**The control panel is divided into four functional groups:**


1. Numeric display.
2. Menu key and indicator lights (LEDs) - changing parameters and switching between display functions.
3. Navigation keys and indicator lights (LEDs).
4. Operation keys and indicator lights (LEDs).

**Select one of the following modes:**

**Status Mode:** Displays the status of the frequency converter or the motor.

If an alarm occurs, the NLCP automatically switches to status mode. A number of alarms can be displayed.

**Quick Setup or Main Menu Mode:** Display parameters and parameter settings.



**NB!**  
Parameter copy is not possible with Numeric Local Control Panel (LCP101).

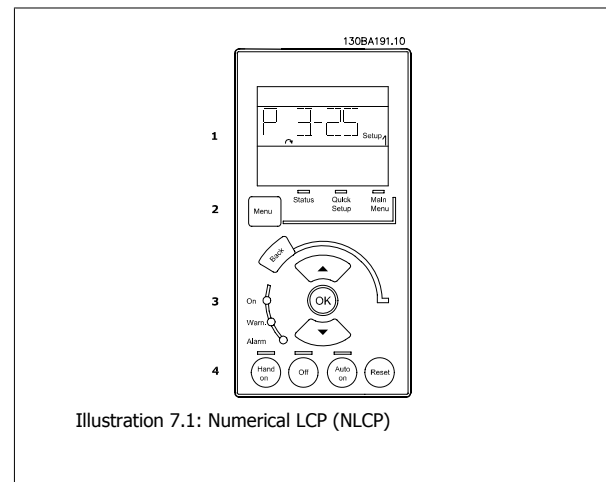


Illustration 7.1: Numerical LCP (NLCP)

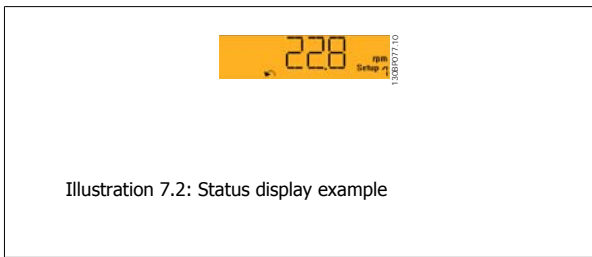


Illustration 7.2: Status display example

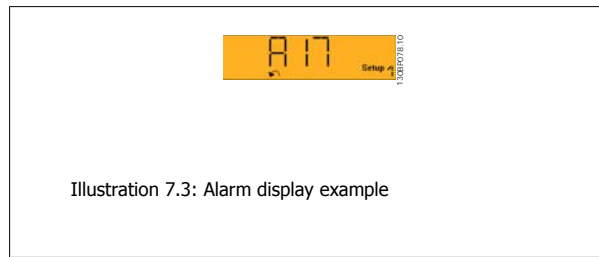


Illustration 7.3: Alarm display example

**Indicator lights (LEDs):**

- Green LED/On: Indicates if control section is on.
- Yellow LED/Wrn.: Indicates a warning.
- Flashing red LED/Alarm: Indicates an alarm.

**Menu key**

**[Menu]** Select one of the following modes:

- Status
- Quick Setup
- Main Menu

**Main Menu**

is used for programming all parameters.

The parameters can be accessed immediately unless a password has been created via par. 0-60 *Main Menu Password*, par. 0-61 *Access to Main Menu w/o Password*, par. 0-65 *Personal Menu Password* or par. 0-66 *Access to Personal Menu w/o Password*.

**Quick Setup** is used to set up the frequency converter using only the most essential parameters.

The parameter values can be changed using the up/down arrows when the value is flashing.

Select Main Menu by pressing the [Menu] key a number of times until the Main Menu LED is lit.

Select the parameter group [xx-\_\_] and press [OK]

Select the parameter [\_\_-xx] and press [OK]

If the parameter is an array parameter select the array number and press [OK]

Select the wanted data value and press [OK]

**Navigation Keys****[Back]**

for stepping backwards

**Arrow [▲] [▼]**

keys are used for manoeuvring between parameter groups, parameters and within parameters

**[OK]**

is used for choosing a parameter marked by the cursor and for enabling the change of a parameter.

**Operation Keys**

Keys for local control are found at the bottom of the control panel.

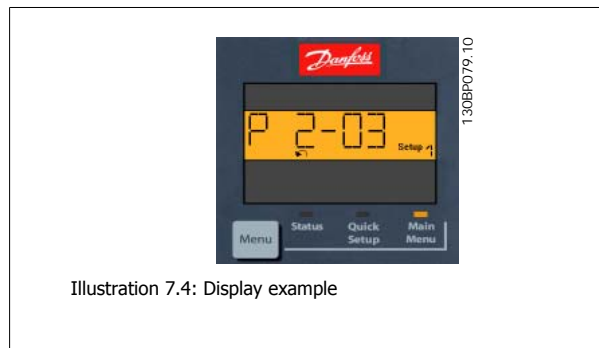


Illustration 7.4: Display example

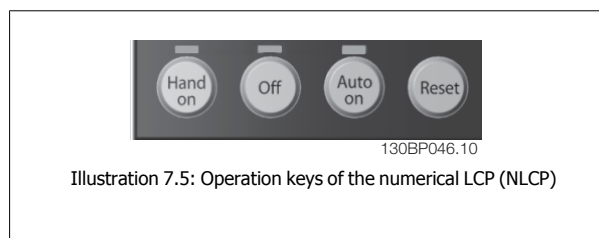


Illustration 7.5: Operation keys of the numerical LCP (NLCP)

**[Hand on]**

enables control of the frequency converter via the LCP. [Hand on] also starts the motor and it is now possible to enter the motor speed data by means of the arrow keys. The key can be *Enabled* [1] or *Disabled* [0] via par. 0-40 *[Hand on] Key on LCP*.

External stop signals activated by means of control signals or a serial bus will override a 'start' command via the LCP.

**The following control signals will still be active when [Hand on] is activated:**

- [Hand on] - [Off] - [Auto on]
- Reset
- Coasting stop inverse
- Reversing
- Set-up select lsb - Set-up select msb
- Stop command from serial communication
- Quick stop
- DC brake

**[Off]**

stops the connected motor. The key can be *Enabled* [1] or *Disabled* [0] via par. 0-41 *[Off] Key on LCP*.

If no external stop function is selected and the [Off] key is inactive the motor can be stopped by disconnecting the mains supply.

**[Auto on]**

enables the frequency converter to be controlled via the control terminals and/or serial communication. When a start signal is applied on the control terminals and/or the bus, the frequency converter will start. The key can be *Enabled* [1] or *Disabled* [0] via par. 0-42 *[Auto on] Key on LCP*.

**NB!**  
An active HAND-OFF-AUTO signal via the digital inputs has higher priority than the control keys [Hand on] [Auto on].



**[Reset]**

is used for resetting the frequency converter after an alarm (trip). The key can be *Enabled* [1] or *Disabled* [0] via par. 0-43 *[Reset] Key on LCP*.

### 7.1.4 Changing Data

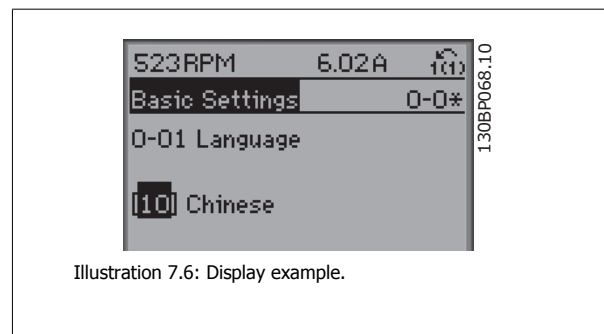
1. Press [Quick Menu] or [Main Menu] key.
2. Use [▲] and [▼] keys keys to find parameter group to edit.
3. Press [OK] key.
4. Use [▲] and [▼] keys to find parameter to edit.
5. Press [OK] key.
6. Use [▲] and [▼] keys to select correct parameter setting. Or, to move to digits within a number, use keys. Cursor indicates digit selected to change. [▲] key increases the value, [▼] key decreases the value.
7. Press [Cancel] key to disregard change, or press [OK] key to accept change and enter new setting.

### 7.1.5 Changing a Text Value

If the selected parameter is a text value, change the text value by means of the up/down navigation keys.

The up key increases the value, and the down key decreases the value.

Place the cursor on the value to be saved and press [OK].



### 7.1.6 Changing a Group of Numeric Data Values

If the chosen parameter represents a numeric data value, change the chosen data value by means of the [←] and [→] navigation keys as well as the up/down [▲] [▼] navigation keys. Use the [←] and [→] navigation keys to move the cursor horizontally.

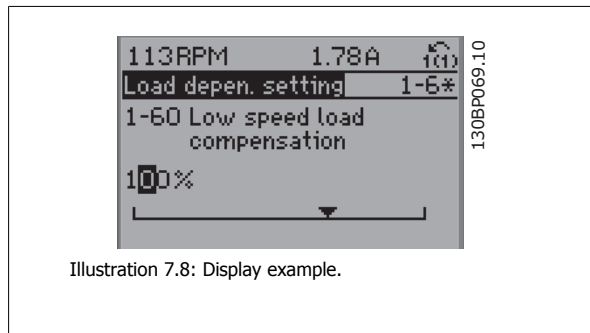


Illustration 7.8: Display example.

Use the up/down navigation keys to change the data value. The up key enlarges the data value, and the down key reduces the data value. Place the cursor on the value to be saved and press [OK].

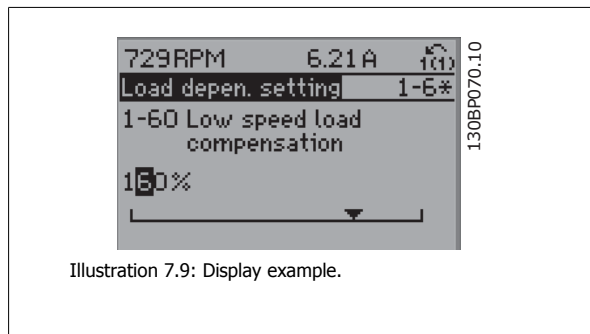


Illustration 7.9: Display example.

7

### 7.1.7 Changing of Data Value, Step-by-Step

Certain parameters can be changed step by step or infinitely variably. This applies to par. 1-20 *Motor Power [kW]*, par. 1-22 *Motor Voltage* and par. 1-23 *Motor Frequency*.

The parameters are changed both as a group of numeric data values and as numeric data values infinitely variably.

### 7.1.8 Read-out and Programming of Indexed Parameters

Parameters are indexed when placed in a rolling stack.

par. 15-30 *Alarm Log: Error Code* to par. 15-32 *Alarm Log: Time* contain a fault log which can be read out. Choose a parameter, press [OK], and use the up/down navigation keys to scroll through the value log.

Use par. 3-10 *Preset Reference* as another example:

Choose the parameter, press [OK], and use the up/down navigation keys keys to scroll through the indexed values. To change the parameter value, select the indexed value and press [OK]. Change the value by using the up/down keys. Press [OK] to accept the new setting. Press [Cancel] to abort. Press [Back] to leave the parameter.


### 7.1.9 Tips and tricks

*	For the majority of water and wastewater applications the Quick Menu, Quick Setup and Function Setups provides the simplest and quickest access to all the typical parameters required.
*	Whenever possible, performing an AMA, will ensure best shaft performance
*	Contrast of the display can be adjusted by pressing [Status] and [▲] for darker display or by pressing [Status] and [▼] for brighter display
*	Under [Quick Menu] and [Changes Made] all parameters that have been changed from factory settings are displayed
*	Press and hold [Main Menu] key for 3 seconds for access to any parameter
*	For service purposes it is recommended to copy all parameters to the LCP, see par 0-50 for further information

Table 7.1: Tips and tricks

### 7.1.10 Quick Transfer of Parameter Settings when using GLCP

Once the set-up of a frequency converter is complete, it is recommended to store (backup) the parameter settings in the GLCP or on a PC via MCT 10 Set-up Software Tool.



**NB!**  
Stop the motor before performing any of these operations.

**Data storage in LCP:**

1. Go to par. 0-50 *LCP Copy*
2. Press the [OK] key
3. Select "All to LCP"
4. Press the [OK] key

All parameter settings are now stored in the GLCP indicated by the progress bar. When 100% is reached, press [OK].

The GLCP can now be connected to another frequency converter and the parameter settings copied to this frequency converter.

**Data transfer from LCP to Frequency converter:**

1. Go to par. 0-50 *LCP Copy*
2. Press the [OK] key
3. Select "All from LCP"
4. Press the [OK] key

The parameter settings stored in the GLCP are now transferred to the frequency converter indicated by the progress bar. When 100% is reached, press [OK].

### 7.1.11 Initialisation to Default Settings


There are two ways to initialise the frequency converter to default: Recommended initialisation and manual initialisation. Please be aware that they have different impact according to the below description.

**Recommended initialisation (via par. 14-22 *Operation Mode*)**

1. Select par. 14-22 *Operation Mode*
2. Press [OK]
3. Select "Initialisation" (for NLCP select "2")
4. Press [OK]
5. Remove power to unit and wait for display to turn off.
6. Reconnect power and the frequency converter is reset. Note that first start-up takes a few more seconds.
7. Press [Reset]

par. 14-22 *Operation Mode* initialises all except:

- par. 14-50 *RFI Filter*
- par. 8-30 *Protocol*
- par. 8-31 *Address*
- par. 8-32 *Baud Rate*
- par. 8-35 *Minimum Response Delay*
- par. 8-36 *Max Response Delay*
- par. 8-37 *Maximum Inter-Char Delay*
- par. 15-00 *Operating Hours* to par. 15-05 *Over Volt's*
- par. 15-20 *Historic Log: Event* to par. 15-22 *Historic Log: Time*
- par. 15-30 *Alarm Log: Error Code* to par. 15-32 *Alarm Log: Time*



**NB!**  
Parameters selected in par. 0-25 *My Personal Menu*, will stay present, with default factory setting.

**Manual initialisation**

**NB!**

When carrying out manual initialisation, serial communication, RFI filter settings and fault log settings are reset. Removes parameters selected in par. 0-25 *My Personal Menu*

1. Disconnect from mains and wait until the display turns off.
- 2a. Press [Status] - [Main Menu] - [OK] at the same time while power up for Graphical LCP (GLCP).
- 2b. Press [Menu] while power up for LCP 101, Numerical Display
3. Release the keys after 5 s.
4. The frequency converter is now programmed according to default settings.

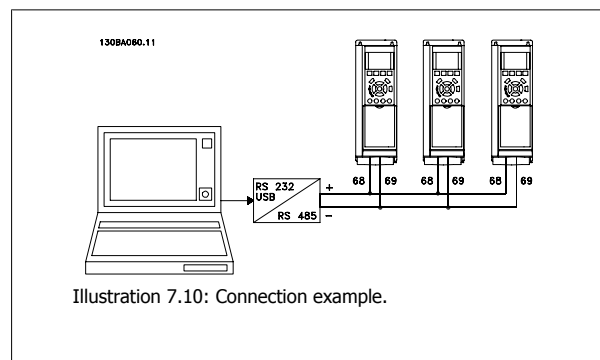
This parameter initialises all except:

- par. 15-00 *Operating Hours*
- par. 15-03 *Power Up's*
- par. 15-04 *Over Temp's*
- par. 15-05 *Over Volt's*

### 7.1.12 RS-485 Bus Connection

One or more frequency converters can be connected to a controller (or master) using the RS-485 standard interface. Terminal 68 is connected to the P signal (TX+, RX+), while terminal 69 is connected to the N signal (TX-,RX-).

If more than one frequency converter is connected to a master, use parallel connections.



In order to avoid potential equalizing currents in the screen, earth the cable screen via terminal 61, which is connected to the frame via an RC-link.

#### Bus termination

The RS-485 bus must be terminated by a resistor network at both ends. If the drive is the first or the last device in the RS-485 loop, set the switch S801 on the control card for ON.

For more information, see the paragraph *Switches S201, S202, and S801*.

### 7.1.13 How to Connect a PC to the frequency converter

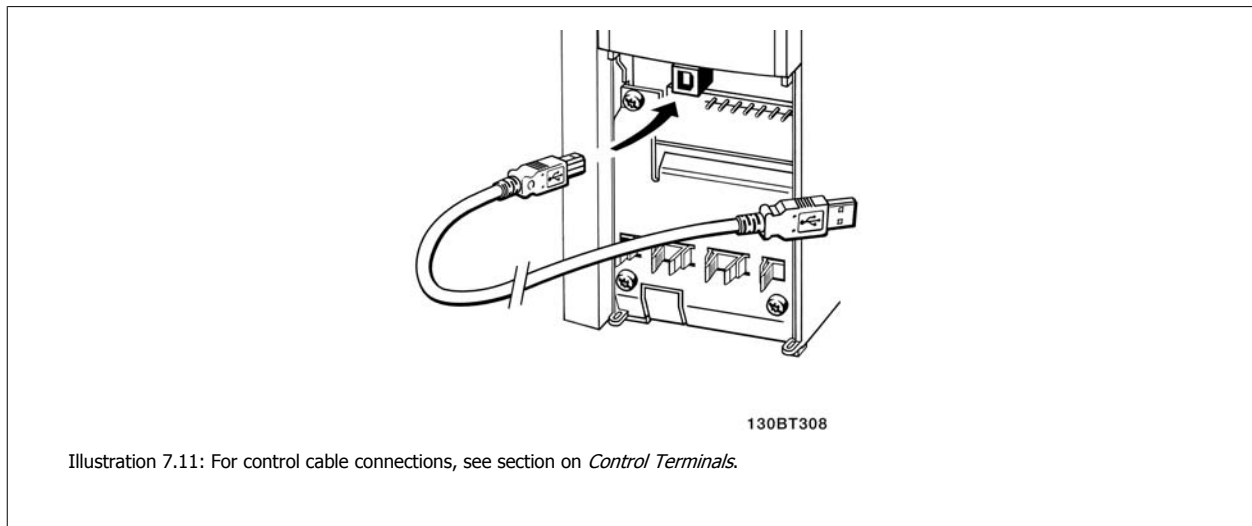
To control or program the frequency converter from a PC, install the PC-based Configuration Tool MCT 10.

The PC is connected via a standard (host/device) USB cable, or via the RS-485 interface as shown in the *Design Guide, chapter How to Install > Installation of misc. connections*.

**NB!**

The USB connection is galvanically isolated from the supply voltage (PELV) and other high-voltage terminals. The USB connection is connected to protection earth on the frequency converter. Use only isolated laptop as PC connection to the USB connector on the frequency converter.





### 7.1.14 PC Software tools

#### PC-based Configuration Tool MCT 10

All Frequency converters are equipped with a serial communication port. Danfoss provides a PC tool for communication between PC and frequency converter, PC-based Configuration Tool MCT 10. Please check the section on *Available Literature* for detailed information on this tool.

#### MCT 10 Set-up Software

MCT 10 has been designed as an easy to use interactive tool for setting parameters in our frequency converters. The software can be downloaded from the Danfoss internet site <http://www.Danfoss.com/BusinessAreas/DrivesSolutions/SoftwareDownload/DDPC+Software+Program.htm>.

The xMCT 10 Set-up software will be useful for:

- Planning a communication network off-line. MCT 10 contains a complete frequency converter database
- Commissioning frequency converters on line
- Saving settings for all frequency converters
- Replacing a frequency converter in a network
- Simple and accurate documentation of frequency converter settings after commissioning.
- Expanding an existing network
- Future developed frequency converters will be supported

MCT 10 set-up software supports Profibus DP-V1 via a Master class 2 connection. It makes it possible to on line read/write parameters in a frequency converter via the Profibus network. This will eliminate the need for an extra communication network.

#### Save Frequency Converter Settings:

1. Connect a PC to the unit via USB com port. (Note: Use a PC, which is isolated from the mains, in conjunction with the USB port. Failure to do so may damage equipment.)
2. Open MCT 10 Set-up Software
3. Choose "Read from drive"
4. Choose "Save as"

All parameters are now stored in the PC.

#### Load Frequency Converter Settings:

1. Connect a PC to the frequency converter via USB com port
2. Open MCT 10 Set-up software
3. Choose "Open"— stored files will be shown


4. Open the appropriate file
5. Choose "Write to drive"

All parameter settings are now transferred to the frequency converter.

A separate manual for MCT 10 Set-up Software is available: *MG.10.Rx.yy*.

#### The MCT 10 Set-up Software Modules

The following modules are included in the software package:

	<b>MCT Set-up 10 Software</b> Setting parameters Copy to and from frequency converters Documentation and print out of parameter settings incl. diagrams
	<b>Ext. User Interface</b> Preventive Maintenance Schedule Clock settings Timed Action Programming Smart Logic Controller Set-up

#### Ordering number:

Please order the CD containing MCT 10 Set-up Software using code number 130B1000.

7

MCT 10 can also be downloaded from the Danfoss Internet: [WWW.DANFOSS.COM](http://WWW.DANFOSS.COM), *Business Area: Motion Controls*.

## 8 How to programme the frequency converter

### 8.1 How to programme

#### 8.1.1 Parameter Set-Up

##### Overview of parameter groups

Group	Title	Function
0-	Operation / Display	Parameters related to the fundamental functions of the frequency converter, function of the LCP buttons and configuration of the LCP display.
1-	Load / Motor	Parameter group for motor settings.
2-	Brakes	Parameter group for setting brake features in the frequency converter.
3-	Reference / Ramps	Parameters for reference handling, definitions of limitations, and configuration of the reaction of the frequency converter to changes.
4-	Limits / Warnings	Parameter group for configuring limits and warnings.
5-	Digital In/Out	Parameter group for configuring the digital inputs and outputs.
6-	Analog In/Out	Parameter group for configuration of the analog inputs and outputs.
8-	Communication and Options	Parameter group for configuring communications and options.
9-	Profibus	Parameter group for Profibus-specific parameters.
10-	DeviceNet Fieldbus	Parameter group for DeviceNet-specific parameters.
13-	Smart Logic	Parameter group for Smart Logic Control
14-	Special Functions	Parameter group for configuring special frequency converter functions.
15-	Drive Information	Parameter group containing frequency converter information such as operating data, hardware configuration and software versions.
16-	Data Readouts	Parameter group for data read-outs, e.g. actual references, voltages, control, alarm, warning and status words.
18-	Info and Readouts	This parameter group contains the last 10 Preventive Maintenance logs.
20-	Drive Closed Loop	This parameter group is used for configuring the closed loop PID Controller that controls the output frequency of the unit.
21-	Extended Closed Loop	Parameters for configuring the three Extended Closed Loop PID Controllers.
22-	Application Functions	These parameters monitor water applications.
23-	Time-based Functions	These parameters are for actions needed to be performed on a daily or weekly basis, e.g. different references for working hours/non-working hours.
25-	Basic Cascade Controller Functions	Parameters for configuring the Basic Cascade Controller for sequence control of multiple pumps.
26-	Analog I/O Option MCB 109	Parameters for configuring the Analog I/O Option MCB 109.
27-	Extended Cascade Control	Parameters for configuring the Extended Cascade Control.
29-	Water Application Functions	Parameters for setting water specific functions.
31-	Bypass Option	Parameters for configuring the Bypass Option

Table 8.1: Parameter Groups

Parameter descriptions and selections are displayed on the graphic (GLCP) or numeric (NLCP) in the display area. (See Section 5 for details.) Access the parameters by pressing the [Quick Menu] or [Main Menu] key on the control panel. The quick menu is used primarily for commissioning the unit at start-up by providing those parameters necessary to start operation. The main menu provides access to all parameters for detailed application programming.

All digital input/output and analog input/output terminals are multifunctional. All terminals have factory default functions suitable for the majority of water applications but if other special functions are required, they must be programmed in parameter group 5 or 6.

#### 8.1.2 Quick Menu Mode

The GLCP provides access to all parameters listed under the Quick Menus. To set parameters using the [Quick Menu] button:

Pressing [Quick Menu] the list indicates the different areas contained in the Quick menu.

##### Efficient Parameter Set-up for Water Applications

The parameters can easily be set up for the vast majority of the water and wastewater applications only by using the [Quick Menu].

**The optimum way to set parameters through the [Quick Menu] is by following the below steps:**

1. Press [Quick Setup] for selecting basic motor settings, ramp times, etc.
2. Press [Function Setups] for setting up the required functionality of the frequency converter - if not already covered by the settings in [Quick Setup].
3. Choose between *General Settings*, *Open Loop Settings* and *Closed Loop Settings*.

It is recommended to do the set-up in the order listed.

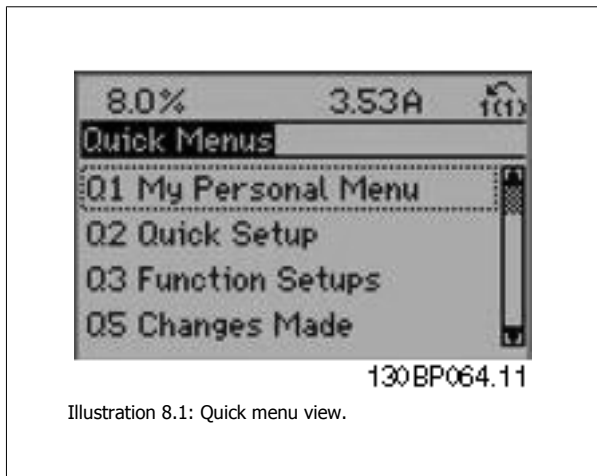


Illustration 8.1: Quick menu view.

Par.	Designation	[Units]
0-01	Language	
1-20	Motor Power	[kW]
1-22	Motor Voltage	[V]
1-23	Motor Frequency	[Hz]
1-24	Motor Current	[A]
1-25	Motor Nominal Speed	[RPM]
3-41	Ramp 1 Ramp up Time	[s]
3-42	Ramp 1 Ramp down Time	[s]
4-11	Motor Speed Low Limit	[RPM]
4-13	Motor Speed High Limit	[RPM]
1-29	Automatic Motor Adaptation (AMA)	

Table 8.2: Quick Setup parameters

If *No Operation* is selected in terminal 27 no connection to +24 V on terminal 27 is necessary to enable start.

If *Coast Inverse* (factory default value) is selected in Terminal 27, a connection to +24V is necessary to enable start.

**NB!**

For detailed parameter descriptions, please see the following section on *Commonly Used Parameters - Explanations*.

**8**

### 8.1.3 Q1 My Personal Menu

Parameters defined by the user can be stored in Q1 My Personal Menu.

Select *My Personal Menu* to display only the parameters, which have been pre-selected and programmed as personal parameters. For example, a pump or equipment OEM may have pre-programmed these to be in My Personal Menu during factory commissioning to make on site commissioning / fine tuning simpler.. These parameters are selected in par. 0-25 *My Personal Menu*. Up to 20 different parameters can be defined in this menu.

Q1 My Personal Menu	
20-21	Setpoint 1
20-93	PID Proportional Gain
20-94	PID Integral Time

### 8.1.4 Q2 Quick Setup

The parameters in Q2 Quick Setup are the basic parameters which are always needed to set-up the frequency converter to operation.

Q2 Quick Setup	
Parameter number and name	Unit
0-01	Language
1-20	Motor Power kW
1-22	Motor Voltage V
1-23	Motor Frequency Hz
1-24	Motor Current A
1-25	Motor Nominal Speed RPM
3-41	Ramp 1 Ramp Up Time s
3-42	Ramp 1 Ramp Down Time s
4-11	Motor Speed Low Limit RPM
4-13	Motor Speed High Limit RPM
1-29	Automatic Motor Adaptation (AMA)

### 8.1.5 Q3 Function Setups

The Function Setup provides quick and easy access to all parameters required for the majority of water and wastewater applications including variable torque, constant torque, pumps, dosing pumps, well pumps, booster pumps, mixer pumps, aeration blowers and other pump and fan applications. Amongst other features it also includes parameters for selecting which variables to display on the LCP, digital preset speeds, scaling of analog references, closed loop single zone and multi-zone applications and specific functions related to water and wastewater applications.

#### How to access Function Set-up - example:




Illustration 8.2: Step 1: Turn on the frequency converter (On LED lights)

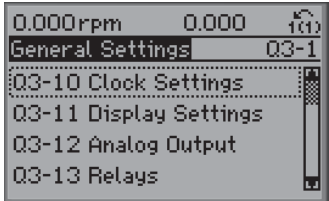


Illustration 8.6: Step 5: Use the up/down navigation keys to scroll down to i.e. 03-12 *Analog Outputs*. Press [OK].




Illustration 8.3: Step 2: Press the [Quick Menus] button (Quick Menu choices appear).

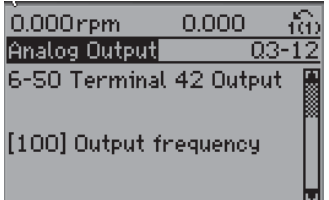


Illustration 8.7: Step 6: Choose parameter 6-50 *Terminal 42 Output*. Press [OK].




Illustration 8.4: Step 3: Use the up/down navigation keys to scroll down to Function Setups. Press [OK].

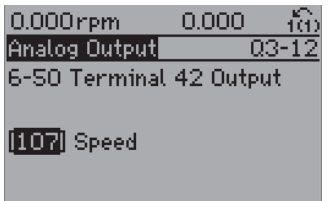


Illustration 8.8: Step 7: Use the up/down navigation keys to select between the different choices. Press [OK].

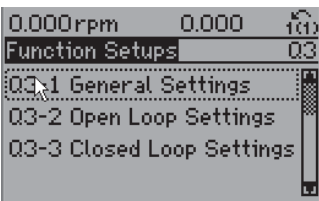


Illustration 8.5: Step 4: Function Setups choices appear. Choose 03-1 *General Settings*. Press [OK].

The Function Setup parameters are grouped in the following way:

Q3-1 General Settings			
Q3-10 Clock Settings	Q3-11 Display Settings	Q3-12 Analog Output	Q3-13 Relays
0-70 Set Date and Time	0-20 Display Line 1.1 Small	6-50 Terminal 42 Output	Relay 1 ⇒ 5-40 Function Relay
0-71 Date Format	0-21 Display Line 1.2 Small	6-51 Terminal 42 Output Min Scale	Relay 2 ⇒ 5-40 Function Relay
0-72 Time Format	0-22 Display Line 1.3 Small	6-52 Terminal 42 Output Max Scale	Option relay 7 ⇒ 5-40 Function Relay
0-74 DST/Summertime	0-23 Display Line 2 Large		Option relay 8 ⇒ 5-40 Function Relay
0-76 DST/Summertime Start	0-24 Display Line 3 Large		Option relay 9 ⇒ 5-40 Function Relay
0-77 DST/Summertime End	0-37 Display Text 1		
	0-38 Display Text 2		
	0-39 Display Text 3		

Q3-2 Open Loop Settings	
Q3-20 Digital Reference	Q3-21 Analog Reference
3-02 Minimum Reference	3-02 Minimum Reference
3-03 Maximum Reference	3-03 Maximum Reference
3-10 Preset Reference	6-10 Terminal 53 Low Voltage
5-13 Terminal 29 Digital Input	6-11 Terminal 53 High Voltage
5-14 Terminal 32 Digital Input	6-14 Terminal 53 Low Ref/Feedb. Value
5-15 Terminal 33 Digital Input	6-15 Terminal 53 High Ref/Feedb. Value

Q3-3 Closed Loop Settings	
Q3-30 Feedback Settings	Q3-31 PID Settings
1-00 Configuration Mode	20-81 PID Normal/Inverse Control
20-12 Reference/Feedb.Unit	20-82 PID Start Speed [RPM]
3-02 Minimum Reference	20-21 Setpoint 1
3-03 Maximum Reference	20-93 PID Proportional Gain
6-20 Terminal 54 Low Voltage	20-94 PID Integral Time
6-21 Terminal 54 High Voltage	
6-24 Terminal 54 Low Ref/Feedb Value	
6-25 Terminal 54 High Ref/Feedb Value	
6-00 Live Zero Timeout Time	
6-01 Live Zero Timeout Function	

8

### 8.1.6 Q5 Changes Made

Q5 Changes Made can be used for fault finding.

**Select *Changes made to get information about:***

- the last 10 changes. Use the up/down navigation keys to scroll between the last 10 changed parameters.
- the changes made since default setting.

Select *Loggings* to get information about the display line read-outs. The information is shown as graphs.

Only display parameters selected in par. 0-20 and par. 0-24 can be viewed. It is possible to store up to 120 samples in the memory for later reference.

Please notice that the parameters listed in the below tables for Q5 only serve as examples as they will vary depending on the programming of the particular frequency converter.

Q5-1 Last 10 Changes
20-94 PID Integral Time
20-93 PID Proportional Gain

Q5-2 Since Factory Setting
20-93 PID Proportional Gain
20-94 PID Integral Time

Q5-3 Input Assignments
Analog Input 53
Analog Input 54

### 8.1.7 Q6 Loggings

Q6 Loggings can be used for fault finding.

Please notice that the parameters listed in the below table for Q6 only serve as examples as they will vary depending on the programming of the particular frequency converter.

Q6 Loggings	
Reference	
Analog Input 53	
Motor Current	
Frequency	
Feedback	
Energy Log	
Trending Cont Bin	
Trending Timed Bin	
Trending Comparison	

### 8.1.8 Main Menu Mode

Both the GLCP and NLCP provide access to the main menu mode. Select the Main Menu mode by pressing the [Main Menu] key. Illustration 6.2 shows the resulting read-out, which appears on the display of the GLCP. Lines 2 through 5 on the display show a list of parameter groups which can be chosen by toggling the up and down buttons.

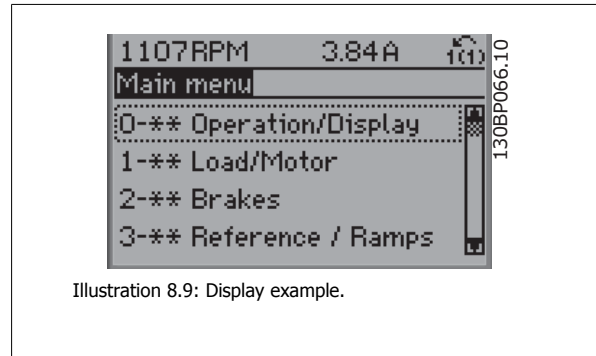


Illustration 8.9: Display example.

Each parameter has a name and number which remain the same regardless of the programming mode. In the Main Menu mode, the parameters are divided into groups. The first digit of the parameter number (from the left) indicates the parameter group number.

All parameters can be changed in the Main Menu. The configuration of the unit (par. 1-00 *Configuration Mode*) will determine other parameters available for programming. For example, selecting Closed Loop enables additional parameters related to closed loop operation. Option cards added to the unit enable additional parameters associated with the option device.

### 8.1.9 Parameter Selection

8

In the Main Menu mode, the parameters are divided into groups. Select a parameter group by means of the navigation keys.

The following parameter groups are accessible:

Group no.	Parameter group:
0	Operation/Display
1	Load/Motor
2	Brakes
3	References/Ramps
4	Limits/Warnings
5	Digital In/Out
6	Analog In/Out
8	Comm. and Options
9	Profibus
10	CAN Fieldbus
11	LonWorks
13	Smart Logic
14	Special Functions
15	Drive Information
16	Data Readouts
18	Data Readouts 2
20	Drive Closed Loop
21	Ext. Closed Loop
22	Application Functions
23	Time-based Functions
24	Fire Mode
25	Cascade Controller
26	Analog I/O Option MCB 109

Table 8.3: Parameter groups.

After selecting a parameter group, choose a parameter by means of the navigation keys.

The middle section on the GLCP display shows the parameter number and name as well as the selected parameter value.

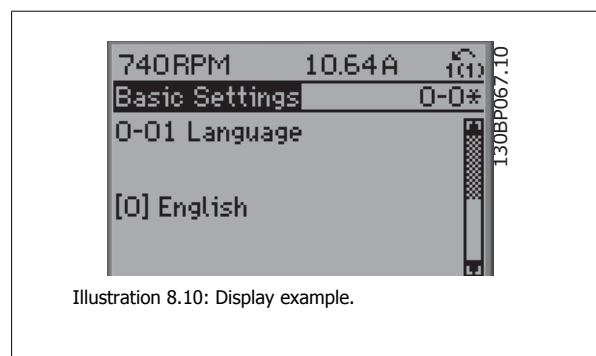


Illustration 8.10: Display example.



## 8.2 Commonly Used Parameters - Explanations

### 8.2.1 Main Menu

The Main Menu includes all available parameters in the VLT® AQUA Drive FC 200 frequency converter.

All parameters are grouped in a logic way with a group name indicating the function of the parameter group.

All parameters are listed by name and number in the section *Parameter Options* in these Operating Instructions.

All parameters included in the Quick Menus (Q1, Q2, Q3, Q5 and Q6) can be found in the following.

Some of the most used parameters for VLT® AQUA Drive applications are also explained in the following section.

For a detailed explanation of all parameters, please refer to the VLT® AQUA Drive Programming Guide MG.20.OX.YY which is available on [www.danfoss.com](http://www.danfoss.com) or by ordering at the local Danfoss office.

## 8.2.2 0-\*\* Operation / Display

Parameters related to the fundamental functions of the frequency converter, function of the LCP buttons and configuration of the LCP display.

### 0-01 Language

**Option:****Function:**

Defines the language to be used in the display.

The frequency converter can be delivered with 4 different language packages. English and German are included in all packages. English cannot be erased or manipulated.

[0] *	English	Part of Language packages 1 - 4
[1]	German	Part of Language packages 1 - 4
[2]	French	Part of Language package 1
[3]	Danish	Part of Language package 1
[4]	Spanish	Part of Language package 1
[5]	Italian	Part of Language package 1
[6]	Swedish	Part of Language package 1
[7]	Dutch	Part of Language package 1
[10]	Chinese	Language package 2
[20]	Finnish	Part of Language package 1
[22]	English US	Part of Language package 4
[27]	Greek	Part of Language package 4
[28]	Portuguese	Part of Language package 4
[36]	Slovenian	Part of Language package 3
[39]	Korean	Part of Language package 2
[40]	Japanese	Part of Language package 2
[41]	Turkish	Part of Language package 4
[42]	Traditional Chinese	Part of Language package 2
[43]	Bulgarian	Part of Language package 3
[44]	Serbian	Part of Language package 3
[45]	Romanian	Part of Language package 3
[46]	Hungarian	Part of Language package 3
[47]	Czech	Part of Language package 3
[48]	Polish	Part of Language package 4
[49]	Russian	Part of Language package 3
[50]	Thai	Part of Language package 2
[51]	Bahasa Indonesian	Part of Language package 2

### 0-20 Display Line 1.1 Small

**Option:****Function:**

Select a variable for display in line 1, left position.

[0]	None	No display value selected
[37]	Display Text 1	Present control word
[38]	Display Text 2	Enables an individual text string to be written, for display in the LCP or to be read via serial communication.
[39]	Display Text 3	Enables an individual text string to be written, for display in the LCP or to be read via serial communication.
[89]	Date and Time Readout	Displays the current date and time.
[953]	Profibus Warning Word	Displays Profibus communication warnings.
[1005]	Readout Transmit Error Counter	View the number of CAN control transmission errors since the last power-up.

[1006]	Readout Receive Error Counter	View the number of CAN control receipt errors since the last power-up.
[1007]	Readout Bus Off Counter	View the number of Bus Off events since the last power-up.
[1013]	Warning Parameter	View a DeviceNet-specific warning word. One separate bit is assigned to every warning.
[1115]	LON Warning Word	Shows the LON-specific warnings.
[1117]	XIF Revision	Shows the version of the external interface file of the Neuron C chip on the LON option.
[1118]	LON Works Revision	Shows the software version of the application program of the Neuron C chip on the LON option.
[1500]	Operating Hours	View the number of running hours of the frequency converter.
[1501]	Running Hours	View the number of running hours of the motor.
[1502]	kWh Counter	View the mains power consumption in kWh.
[1600]	Control Word	View the Control Word sent from the frequency converter via the serial communication port in hex code.
[1601] *	Reference [Unit]	Total reference (sum of digital/analog/preset/bus/freeze ref./catch up and slow-down) in selected unit.
[1602]	Reference %	Total reference (sum of digital/analog/preset/bus/freeze ref./catch up and slow-down) in percent.
[1603]	Status Word	Present status word
[1605]	Main Actual Value [%]	One or more warnings in a Hex code
[1609]	Custom Readout	View the user-defined readouts as defined in par. 0-30, 0-31 and 0-32.
[1610]	Power [kW]	Actual power consumed by the motor in kW.
[1611]	Power [hp]	Actual power consumed by the motor in HP.
[1612]	Motor Voltage	Voltage supplied to the motor.
[1613]	Motor Frequency	Motor frequency, i.e. the output frequency from the frequency converter in Hz.
[1614]	Motor Current	Phase current of the motor measured as effective value.
[1615]	Frequency [%]	Motor frequency, i.e. the output frequency from the frequency converter in percent.
[1616]	Torque [Nm]	Present motor load as a percentage of the rated motor torque.
[1617]	Speed [RPM]	Speed in RPM (revolutions per minute) i.e. the motor shaft speed in closed loop based on the entered motor nameplate data, the output frequency and the load on the frequency converter.
[1618]	Motor Thermal	Thermal load on the motor, calculated by the ETR function. See also parameter group 1-9* Motor Temperature.
[1622]	Torque [%]	Shows the actual torque produced, in percentage.
[1630]	DC Link Voltage	Intermediate circuit voltage in the frequency converter.
[1632]	BrakeEnergy/s	Present brake power transferred to an external brake resistor. Stated as an instantaneous value.
[1633]	BrakeEnergy/2 min	Brake power transferred to an external brake resistor. The mean power is calculated continuously for the most recent 120 seconds.
[1634]	Heatsink Temp.	Present heat sink temperature of the frequency converter. The cut-out limit is 95 ±5 °C; cutting back in occurs at 70 ±5° C.
[1635]	Thermal Drive Load	Percentage load of the inverters
[1636]	Inv. Nom. Current	Nominal current of the frequency converter
[1637]	Inv. Max. Current	Maximum current of the frequency converter
[1638]	SL Control State	State of the event executed by the control
[1639]	Control Card Temp.	Temperature of the control card.
[1650]	External Reference	Sum of the external reference as a percentage, i.e. the sum of analog/pulse/bus.
[1652]	Feedback [Unit]	Signal value in units from the programmed digital input(s).
[1653]	Digi Pot Reference	View the contribution of the digital potentiometer to the actual reference Feedback.
[1654]	Feedback 1 [Unit]	View the value of Feedback 1. See also par. 20-0*.
[1655]	Feedback 2 [Unit]	View the value of Feedback 2. See also par. 20-0*.
[1656]	Feedback 3 [Unit]	View the value of Feedback 3. See also par. 20-0*.
[1658]	PID Output [%]	Returns the Drive Closed Loop PID controller output value in percent.

[1659]	Adjusted Setpoint	Displays the actual operating set-point after it is modified by flow compensation. See parameters 22-8*.
[1660]	Digital Input	Displays the status of the digital inputs. Signal low = 0; Signal high = 1. Regarding order, see par. 16-60. Bit 0 is at the extreme right.
[1661]	Terminal 53 Switch Setting	Setting of input terminal 53. Current = 0; Voltage = 1.
[1662]	Analog Input 53	Actual value at input 53 either as a reference or protection value.
[1663]	Terminal 54 Switch Setting	Setting of input terminal 54. Current = 0; Voltage = 1.
[1664]	Analog Input 54	Actual value at input 54 either as reference or protection value.
[1665]	Analog Output 42 [mA]	Actual value at output 42 in mA. Use par. 6-50 to select the variable to be represented by output 42.
[1666]	Digital Output [bin]	Binary value of all digital outputs.
[1667]	Freq. Input #29 [Hz]	Actual value of the frequency applied at terminal 29 as a pulse input.
[1668]	Freq. Input #33 [Hz]	Actual value of the frequency applied at terminal 33 as a pulse input.
[1669]	Pulse Output #27 [Hz]	Actual value of pulses applied to terminal 27 in digital output mode.
[1670]	Pulse Output #29 [Hz]	Actual value of pulses applied to terminal 29 in digital output mode.
[1671]	Relay Output [bin]	View the setting of all relays.
[1672]	Counter A	View the present value of Counter A.
[1673]	Counter B	View the present value of Counter B.
[1675]	Analog input X30/11	Actual value of the signal on input X30/11 (General Purpose I/O Card. Option)
[1676]	Analog input X30/12	Actual value of the signal on input X30/12 (General Purpose I/O Card. Optional)
[1677]	Analog output X30/8 [mA]	Actual value at output X30/8 (General Purpose I/O Card. Optional) Use Par. 6-60 to select the variable to be shown.
[1680]	Fieldbus CTW 1	Control word (CTW) received from the Bus Master.
[1682]	Fieldbus REF 1	Main reference value sent with control word via the serial communications network e.g. from the BMS, PLC or other master controller.
[1684]	Comm. Option STW	Extended fieldbus communication option status word.
[1685]	FC Port CTW 1	Control word (CTW) received from the Bus Master.
[1686]	FC Port REF 1	Status word (STW) sent to the Bus Master.
[1690]	Alarm Word	One or more alarms in a Hex code (used for serial communications)
[1691]	Alarm Word 2	One or more alarms in a Hex code (used for serial communications)
[1692]	Warning Word	One or more warnings in a Hex code (used for serial communications)
[1693]	Warning Word 2	One or more warnings in a Hex code (used for serial communications)
[1694]	Ext. Status Word	One or more status conditions in a Hex code (used for serial communications)
[1695]	Ext. Status Word 2	One or more status conditions in a Hex code (used for serial communications)
[1696]	Maintenance Word	The bits reflect the status for the programmed Preventive Maintenance Events in parameter group 23-1*
[1830]	Analog Input X42/1	Shows the value of the signal applied to terminal X42/1 on the Analog I/O card.
[1831]	Analog Input X42/3	Shows the value of the signal applied to terminal X42/3 on the Analog I/O card.
[1832]	Analog Input X42/5	Shows the value of the signal applied to terminal X42/5 on the Analog I/O card.
[1833]	Analog Out X42/7 [V]	Shows the value of the signal applied to terminal X42/7 on the Analog I/O card.
[1834]	Analog Out X42/9 [V]	Shows the value of the signal applied to terminal X42/9 on the Analog I/O card.
[1835]	Analog Out X42/11 [V]	Shows the value of the signal applied to terminal X42/11 on the Analog I/O card.
[2117]	Ext. 1 Reference [Unit]	The value of the reference for extended Closed Loop Controller 1
[2118]	Ext. 1 Feedback [Unit]	The value of the feedback signal for extended Closed Loop Controller 1
[2119]	Ext. 1 Output [%]	The value of the output from extended Closed Loop Controller 1
[2137]	Ext. 2 Reference [Unit]	The value of the reference for extended Closed Loop Controller 2
[2138]	Ext. 2 Feedback [Unit]	The value of the feedback signal for extended Closed Loop Controller 2
[2139]	Ext. 2 Output [%]	The value of the output from extended Closed Loop Controller 2

[2157]	Ext. 3 Reference [Unit]	The value of the reference for extended Closed Loop Controller 3
[2158]	Ext. 3 Feedback [Unit]	The value of the feedback signal for extended Closed Loop Controller 3
[2159]	Ext. Output [%]	The value of the output from extended Closed Loop Controller 3
[2230]	No-Flow Power	The calculated No Flow Power for the actual operating speed
[2580]	Cascade Status	Status for the operation of the Cascade Controller
[2581]	Pump Status	Status for the operation of each individual pump controlled by the Cascade Controller
[2791]	Cascade Reference	Reference output for use with follower drives.
[2792]	% Of Total Capacity	Readout parameter to show the system operating point as a % capacity of total system capacity.
[2793]	Cascade Option Status	Readout parameter to show the status of the cascade system.

### 0-21 Display Line 1.2 Small

**Option:**

**Function:**

Select a variable for display in line 1, middle position.

[1662] *	Analog input 53	The options are the same as those listed for par. 0-20 <i>Display Line 1.1 Small</i> .
----------	-----------------	--

### 0-22 Display Line 1.3 Small

**Option:**

**Function:**

Select a variable for display in line 1, right position.

[1614] *	Motor Current	The options are the same as those listed for par. 0-20 <i>Display Line 1.1 Small</i> .
----------	---------------	--

### 0-23 Display Line 2 Large

**Option:**

**Function:**

Select a variable for display in line 2.

[1615] *	Frequency	The options are the same as those listed for par. 0-20 <i>Display Line 1.1 Small</i>
----------	-----------	--

### 0-24 Display Line 3 Large

**Option:**

**Function:**

[1652] *	Feedback [Unit]	The options are the same as those listed for par. 0-20 <i>Display Line 1.1 Small</i> .
----------	-----------------	--

Select a variable for display in line 2.

### 0-37 Display Text 1

**Range:**

0 N/A\* [0 - 0 N/A]

**Function:**

In this parameter it is possible to write an individual text string for display in the LCP or to be read via serial communication. If to be displayed permanently select Display Text 1 in par. 0-20 *Display Line 1.1 Small*, par. 0-21 *Display Line 1.2 Small*, par. 0-22 *Display Line 1.3 Small*, par. 0-23 *Display Line 2 Large* or par. 0-24 *Display Line 3 Large*. Use the ▲ or ▼ buttons on the LCP to change a character. Use the ◀ and ▶ buttons to move the cursor. When a character is highlighted by the cursor, it can be changed. Use the ▲ or ▼ buttons on the LCP to change a character. A character can be inserted by placing the cursor between two characters and pressing ▲ or ▼.

### 0-38 Display Text 2

**Range:**

0 N/A\* [0 - 0 N/A]

**Function:**

In this parameter it is possible to write an individual text string for display in the LCP or to be read via serial communication. If to be displayed permanently select Display Text 2 in par. 0-20 *Display Line 1.1 Small*, par. 0-21 *Display Line 1.2 Small*, par. 0-22 *Display Line 1.3 Small*, par. 0-23 *Display Line 2 Large* or par. 0-24 *Display Line 3 Large*. Use the ▲ or ▼ buttons on the LCP to change a character. Use the ◀ and ▶ buttons to move the cursor. When a character is highlighted by the cursor, this character can be changed. A character can be inserted by placing the cursor between two characters and pressing ▲ or ▼.

**0-39 Display Text 3****Range:**

0 N/A\* [0 - 0 N/A]

**Function:**

In this parameter it is possible to write an individual text string for display in the LCP or to be read via serial communication. If to be displayed permanently select Display Text 3 in par. 0-20 *Display Line 1.1 Small*, par. 0-21 *Display Line 1.2 Small*, par. 0-22 *Display Line 1.3 Small*, par. 0-23 *Display Line 2 Large* or par. 0-24 *Display Line 3 Large*. Use the ▲ or ▼ buttons on the LCP to change a character. Use the ◀ and ▶ buttons to move the cursor. When a character is highlighted by the cursor, this character can be changed. A character can be inserted by placing the cursor between two characters and pressing ▲ or ▼.

**0-70 Set Date and Time****Range:**

2000-01-01 [2000-01-01 00:00]  
00:00 –  
2099-12-01  
23:59 \*

**Function:**

Sets the date and time of the internal clock. The format to be used is set in par. 0-71 and 0-72.

**NB!**

This parameter does not display the actual time. This can be read in par. 0-89. The clock will not begin counting until a setting different from default has been made.

**0-71 Date Format****Option:**

[0] \* YYYY-MM-DD  
[1] DD-MM-YYYY  
[2] MM/DD/YYYY

**Function:**

Sets the date format to be used in the LCP.  
Sets the date format to be used in the LCP.  
Sets the date format to be used in the LCP.

**0-72 Time Format****Option:**

[0] \* 24 h  
[1] 12 h

**Function:**

Sets the time format to be used in the LCP.

**0-74 DST/Summertime****Option:**

[0] \* Off  
[2] Manual

**Function:**

Choose how Daylight Saving Time/Summertime should be handled. For manual DST/Summertime enter the start date and end date in par. 0-76 *DST/Summertime Start* and par. 0-77 *DST/Summertime End*.

**0-76 DST/Summertime Start****Range:**

0 N/A\* [0 - 0 N/A]

**Function:**

Sets the date and time when summertime/DST starts. The date is programmed in the format selected in par. 0-71 *Date Format*.

**0-77 DST/Summertime End****Range:**

0 N/A\* [0 - 0 N/A]

**Function:**

Sets the date and time when summertime/DST ends. The date is programmed in the format selected in par. 0-71 *Date Format*.

**8.2.3 General Settings, 1-0\***

Define whether the frequency converter operates in open loop or closed loop.

### 1-00 Configuration Mode

**Option:**

**Function:**

[0] \* Open Loop

Motor speed is determined by applying a speed reference or by setting desired speed when in Hand Mode.  
Open Loop is also used if the frequency converter is part of a closed loop control system based on an external PID controller providing a speed reference signal as output.

[3] Closed Loop

Motor Speed will be determined by a reference from the built-in PID controller varying the motor speed as part of a closed loop control process (e.g. constant pressure or flow). The PID controller must be configured in par. 20-\*\* or via the Function Setups accessed by pressing the [Quick Menus] button.



**NB!**

This parameter cannot be changed when motor is running.



**NB!**

When set for Closed Loop, the commands Reversing and Start Reversing will not reverse the direction of the motor.

### 1-20 Motor Power [kW]

**Range:**

**Function:**

4.00 kW\* [0.09 - 3000.00 kW]

Enter the nominal motor power in kW according to the motor nameplate data. The default value corresponds to the nominal rated output of the unit.  
This parameter cannot be adjusted while the motor is running. Depending on the choices made in par. 0-03 *Regional Settings*, either par. 1-20 *Motor Power [kW]* or par. 1-21 *Motor Power [HP]* is made invisible.

### 1-22 Motor Voltage

**Range:**

**Function:**

400. V\* [10. - 1000. V]

Enter the nominal motor voltage according to the motor nameplate data. The default value corresponds to the nominal rated output of the unit.  
This parameter cannot be adjusted while the motor is running.

### 1-23 Motor Frequency

**Range:**

**Function:**

50. Hz\* [20 - 1000 Hz]

Select the motor frequency value from the motor nameplate data. For 87 Hz operation with 230/400 V motors, set the nameplate data for 230 V/50 Hz. Adapt par. 4-13 *Motor Speed High Limit [RPM]* and par. 3-03 *Maximum Reference* to the 87 Hz application.



**NB!**

This parameter cannot be adjusted while the motor is running.

### 1-24 Motor Current

**Range:**

**Function:**

7.20 A\* [0.10 - 10000.00 A]

Enter the nominal motor current value from the motor nameplate data. This data is used for calculating motor torque, motor thermal protection etc.



**NB!**  
This parameter cannot be adjusted while the motor is running.

### 1-25 Motor Nominal Speed

**Range:**

1420. RPM\* [100 - 60000 RPM]

**Function:**

Enter the nominal motor speed value from the motor nameplate data. This data is used for calculating automatic motor compensations.



**NB!**  
This parameter cannot be changed while the motor is running.

### 1-29 Automatic Motor Adaptation (AMA)

**Option:**

[0] \*

Off

**Function:**

The AMA function optimizes dynamic motor performance by automatically optimizing the advanced motor parameters par. 1-30 *Stator Resistance (Rs)* to par. 1-35 *Main Reactance (Xh)* while the motor is stationary.

No function

[1]

Enable complete AMA

performs AMA of the stator resistance  $R_s$ , the rotor resistance  $R_r$ , the stator leakage reactance  $X_{l1}$ , the rotor leakage reactance  $X_{l2}$  and the main reactance  $X_h$ .

[2]

Enable reduced AMA

performs a reduced AMA of the stator resistance  $R_s$  in the system only. Select this option if an LC filter is used between the frequency converter and the motor.

Activate the AMA function by pressing [Hand on] after selecting [1] or [2]. See also the section *Automatic Motor Adaptation*. After a normal sequence, the display will read: "Press [OK] to finish AMA". After pressing the [OK] key the frequency converter is ready for operation.

Note:

- For the best adaptation of the frequency converter, run AMA on a cold motor
- AMA cannot be performed while the motor is running



**NB!**  
It is important to set motor par. 1-2\* Motor Data correctly, since these form part of the AMA algorithm. An AMA must be performed to achieve optimum dynamic motor performance. It may take up to 10 min., depending on motor power rating.




**NB!**  
Avoid generating external torque during AMA



**NB!**  
If one of the settings in par. 1-2\* Motor Data is changed, par. 1-30 *Stator Resistance (Rs)* to par. 1-39 *Motor Poles*, the advanced motor parameters, will return to default setting.  
This parameter cannot be adjusted while the motor is running





**NB!**  
Full AMA should be run without filter only while reduced AMA should be run with filter.

See section: *Application Examples > Automatic Motor Adaptation* in the Design Guide.

### 8.2.4 3-0\* Reference Limits

Parameters for setting the reference unit, limits and ranges.


#### 3-02 Minimum Reference

**Range:**

0.000 Ref- [-999999.999 - par. 3-03 ReferenceFeed-ceFeedbackUnit] backUnit\*

**Function:**

Enter the Minimum Reference. The Minimum Reference is the lowest value obtainable by summing all references. The Minimum Reference value and unit matches the configuration choice made in par. 1-00 *Configuration Mode* and par. 20-12 *Reference/Feedback Unit*, respectively.



**NB!**  
This parameter is used in open loop only.


#### 3-03 Maximum Reference

**Range:**

50.000 Ref- [par. 3-02 - 999999.999 ReferenceFeed-ceFeedbackUnit] backUnit\*

**Function:**

Enter the maximum acceptable value for the remote reference. The Maximum Reference value and unit matches the configuration choice made in par. 1-00 *Configuration Mode* and par. 20-12 *Reference/Feedback Unit*, respectively.



**NB!**  
If operating with par. 1-00, Configuration Mode set for Closed Loop [3], par. 20-14, Maximum Reference/Feedb. must be used.

#### 3-10 Preset Reference

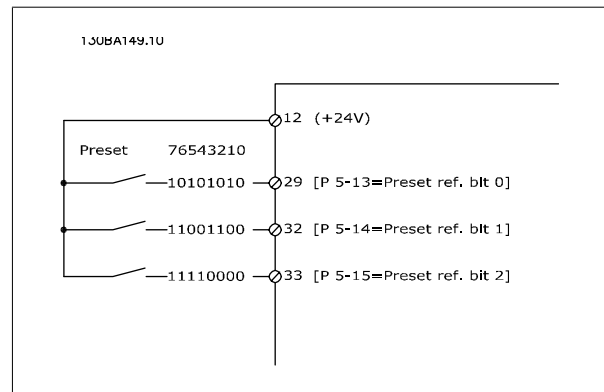
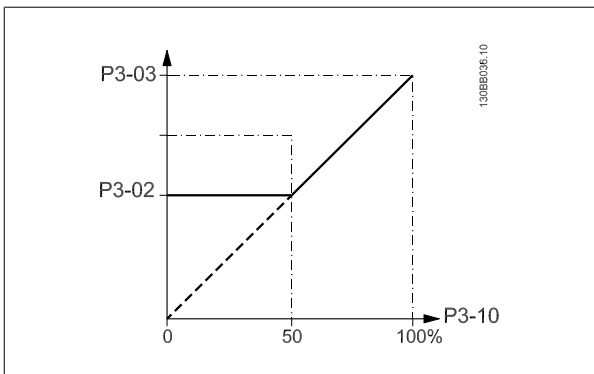
Array [8]

**Range:**

0.00 %\* [-100.00 - 100.00 %]

**Function:**

Enter up to eight different preset references (0-7) in this parameter, using array programming. The preset reference is stated as a percentage of the value Ref<sub>MAX</sub> (par. 3-03 *Maximum Reference*, for closed loop see par. 20-14 *Maximum Reference/Feedb.*). When using preset references, select Preset ref. bit 0 / 1 / 2 [16], [17] or [18] for the corresponding digital inputs in parameter group 5-1\* Digital Inputs.



**3-41 Ramp 1 Ramp Up Time****Range:**

10.00 s\* [1.00 - 3600.00 s]

**Function:**

Enter the ramp-up time, i.e. the acceleration time from 0 RPM to par. 1-25 *Motor Nominal Speed*. Choose a ramp-up time such that the output current does not exceed the current limit in par. 4-18 *Current Limit* during ramping. See ramp-down time in par. 3-42 *Ramp 1 Ramp Down Time*.

$$par.3 - 41 = \frac{tacc \times nnorm [par.1 - 25]}{ref[rpm]} [s]$$

**3-42 Ramp 1 Ramp Down Time****Range:**

20.00 s\* [1.00 - 3600.00 s]

**Function:**

Enter the ramp-down time, i.e. the deceleration time from par. 1-25 *Motor Nominal Speed* to 0 RPM. Choose a ramp-down time such that no over-voltage arises in the inverter due to regenerative operation of the motor, and such that the generated current does not exceed the current limit set in par. 4-18 *Current Limit*. See ramp-up time in par. 3-41 *Ramp 1 Ramp Up Time*.

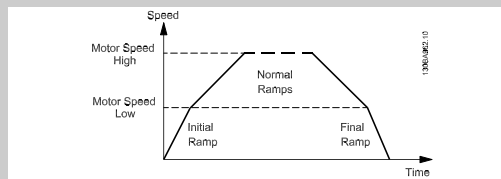
$$par.3 - 42 = \frac{tdec \times nnorm [par.1 - 25]}{ref[rpm]} [s]$$

**3-84 Initial Ramp Time****Range:**

0 s\* [0 - 60 s]

**Function:**

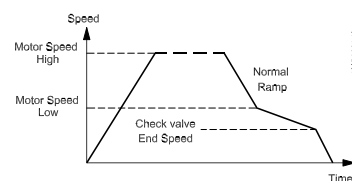
Enter the initial ramp up time from zero speed to Motor Speed Low Limit, par. 4-11 or 4-12. Submersible deep well pumps can be damaged by running below minimum speed. A fast ramp time below minimum pump speed is recommended. This parameter may be applied as a fast ramp rate from zero speed to Motor Speed Low Limit.

**3-85 Check Valve Ramp Time****Range:**

0 s\* [0 - 60 s]

**Function:**

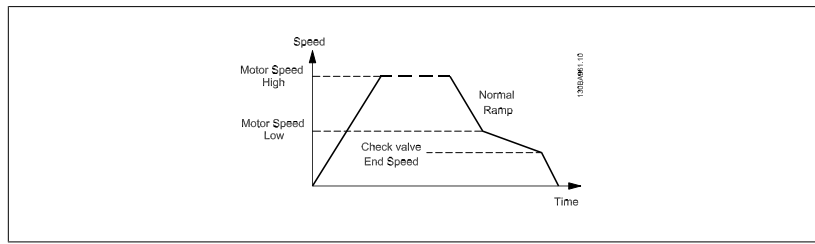
In order to protect ball check valves in a stop situation, the check valve ramp can be utilized as a slow ramp rate from par. 4-11 *Motor Speed Low Limit [RPM]* or par. 4-12 *Motor Speed Low Limit [Hz]* to Check Valve Ramp End Speed, set by the user in par. 3-86 or par. 3-87. When par. 3-85 is different from 0 seconds, the Check Valve Ramp Time is effectuated and will be used to ramp down the speed from Motor Speed Low Limit to the Check Valve End Speed in par. 3-86 or par. 3-87.

**3-86 Check Valve Ramp End Speed [RPM]****Range:**

0 [RPM]\* [0 - Motor Speed Low Limit [RPM]]

**Function:**

Set the speed in [RPM] below Motor Speed Low Limit where the Check Valve is expected to be closed and the Check Valve no longer shall be active.



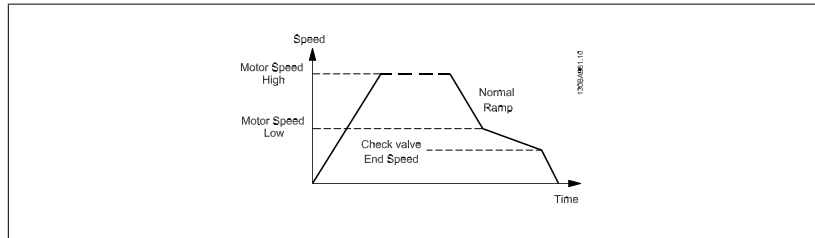
### 3-87 Check Valve Ramp End Speed [Hz]

**Range:**

0 [Hz]\* [0 – Motor Speed Low Limit [Hz]]

**Function:**

Set the speed in [Hz] below Motor Speed Low Limit where the Check Valve Ramp will no longer be active.



### 3-88 Final Ramp Time

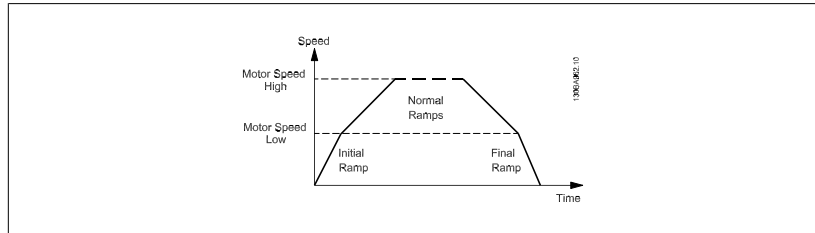
**Range:**

0 [s]\* [0 – 60 [s]]

**Function:**

Enter the Final Ramp Time to be used when ramping down from Motor Speed Low Limit, par. 4-11 or 4-12, to zero speed.

Submersible deep well pumps can be damaged by running below minimum speed. A fast ramp time below minimum pump speed is recommended. This parameter may be applied as a fast ramp rate from Motor Speed Low Limit to zero speed.



## 8.2.5 4-\*\* Limits and Warnings

Parameter group for configuring limits and warnings.

### 4-11 Motor Speed Low Limit [RPM]

**Range:**


0 RPM\* [0 - par. 4-13 RPM]


**Function:**

Enter the minimum limit for motor speed. The Motor Speed Low Limit can be set to correspond to the manufacturer's recommended minimum motor speed. The Motor Speed Low Limit must not exceed the setting in par. 4-13 *Motor Speed High Limit [RPM]*.

**4-13 Motor Speed High Limit [RPM]**

Range:	Function:
1500. RPM* [par. 4-11 - 60000. RPM]	Enter the maximum limit for motor speed. The Motor Speed High Limit can be set to correspond to the manufacturer's maximum rated motor. The Motor Speed High Limit must exceed the setting in par. 4-11 <i>Motor Speed Low Limit [RPM]</i> . Only par. 4-11 <i>Motor Speed Low Limit [RPM]</i> or par. 4-12 <i>Motor Speed Low Limit [Hz]</i> will be displayed depending on other parameters in the Main Menu and depending on default settings dependant on global location.

 **NB!**  
The output frequency value of the frequency converter must not exceed a value higher than 1/10 of the switching frequency.

 **NB!**  
Any changes in par. 4-13 *Motor Speed High Limit [RPM]* will reset the value in par. 4-53 *Warning Speed High* to the same value as set in par. 4-13 *Motor Speed High Limit [RPM]*.

**8.2.6 5-\*\* Digital In/Out**

Parameter group for configuring the digital input and output.

**5-01 Terminal 27 Mode**

Option:	Function:
[0] * Input	Defines terminal 27 as a digital input.
[1] Output	Defines terminal 27 as a digital output.

Please not that this parameter cannot be adjusted while the motor is running.

**8.2.7 5-1\* Digital Inputs**

Parameters for configuring the input functions for the input terminals.

The digital inputs are used for selecting various functions in the frequency converter. All digital inputs can be set to the following functions:


Digital input function	Select	Terminal
No operation	[0]	All *term 32, 33
Reset	[1]	All
Coast inverse	[2]	All
Coast and reset inverse	[3]	All
DC-brake inverse	[5]	All
Stop inverse	[6]	All
External interlock	[7]	All
Start	[8]	All *term 18
Latched start	[9]	All
Reversing	[10]	All *term 19
Start reversing	[11]	All
Jog	[14]	All *term 29
Preset reference on	[15]	All
Preset ref bit 0	[16]	All
Preset ref bit 1	[17]	All
Preset ref bit 2	[18]	All
Freeze reference	[19]	All
Freeze output	[20]	All
Speed up	[21]	All
Speed down	[22]	All
Set-up select bit 0	[23]	All
Set-up select bit 1	[24]	All
Pulse input	[32]	term 29, 33
Ramp bit 0	[34]	All
Mains failure inverse	[36]	All

Run Permissive	[52]	
Hand start	[53]	
Auto start	[54]	
DigiPot Increase	[55]	All
DigiPot Decrease	[56]	All
DigiPot Clear	[57]	All
Counter A (up)	[60]	29, 33
Counter A (down)	[61]	29, 33
Reset Counter A	[62]	All
Counter B (up)	[63]	29, 33
Counter B (down)	[64]	29, 33
Reset Counter B	[65]	All
Sleep Mode	[66]	
Reset Maintenance Word	[78]	
Lead Pump Start	[120]	
Lead Pump Alternation	[121]	
Pump 1 Interlock	[130]	
Pump 2 Interlock	[131]	
Pump 3 Interlock	[132]	

All = Terminals 18, 19, 27, 29, 32, X30/2, X30/3, X30/4. X30/ are the terminals on MCB 101.

Functions dedicated to only one digital input are stated in the associated parameter.

All digital inputs can be programmed to these functions:


[0]	No operation	No reaction to signals transmitted to terminal.
[1]	Reset	Resets frequency converter after a TRIP/ALARM. Not all alarms can be reset.
[2]	Coast inverse	Leaves motor in free mode. Logic '0' => coasting stop. (Default Digital input 27): Coasting stop, inverted input (NC).
[3]	Coast and reset inverse	Reset and coasting stop Inverted input (NC). Leaves motor in free mode and resets the frequency converter. Logic '0' => coasting stop and reset.
[5]	DC-brake inverse	Inverted input for DC braking (NC). Stops motor by energizing it with a DC current for a certain time period. See par. 2-01 to par. 2-03. The function is only active when the value in par. 2-02 is different from 0. Logic '0' => DC braking.
[6]	Stop inverse	Stop Inverted function. Generates a stop function when the selected terminal goes from logical level '1' to '0'. The stop is performed according to the selected ramp time (par. 3-42 and par. 3-52).
<div style="display: flex; align-items: center;">  <div> <p><b>NB!</b></p> <p>When the frequency converter is at the torque limit and has received a stop command, it may not stop by itself. To ensure that the frequency converter stops, configure a digital output to <i>Torque limit &amp; stop</i> [27] and connect this digital output to a digital input that is configured as coast.</p> </div> </div>		
[7]	External Interlock	Same function as Coasting stop, inverse, but External Interlock generates the alarm message 'external fault' on the display when the terminal which is programmed for Coast Inverse is logic '0'. The alarm message will also be active via digital outputs and relay outputs, if programmed for External Interlock. The alarm can be reset using a digital input or the [RESET] key if the cause for the External Interlock has been removed. A delay can be programmed in par. 22-00, External Interlock Time. After applying a signal to the input, the reaction described above will be delayed with the time set in par. 22-00.
[8]	Start	Select start for a start/stop command. Logic '1' = start, logic '0' = stop. (Default Digital input 18)
[9]	Latched start	Motor starts, if a pulse is applied for min. 2 ms. Motor stops when Stop inverse is activated
[10]	Reversing	Changes direction of motor shaft rotation. Select Logic '1' to reverse. The reversing signal only changes the direction of rotation. It does not activate the start function. Select both directions in par. 4-10 <i>Motor Speed Direction</i> . (Default Digital input 19).
[11]	Start reversing	Used for start/stop and for reversing on the same wire. Signals on start are not allowed at the same time.
[14]	Jog	Used for activating jog speed. See par. 3-11. (Default Digital input 29)

[15]	Preset reference on	Used for shifting between external reference and preset reference. It is assumed that <i>External/preset</i> [1] has been selected in par. 3-04. Logic '0' = external reference active; logic '1' = one of the eight preset references is active.
[16]	Preset ref bit 0	Enables a choice between one of the eight preset references according to the table below.
[17]	Preset ref bit 1	Enables a choice between one of the eight preset references according to the table below.
[18]	Preset ref bit 2	Enables a choice between one of the eight preset references according to the table below.

Preset ref. bit	2	1	0
Preset ref. 0	0	0	0
Preset ref. 1	0	0	1
Preset ref. 2	0	1	0
Preset ref. 3	0	1	1
Preset ref. 4	1	0	0
Preset ref. 5	1	0	1
Preset ref. 6	1	1	0
Preset ref. 7	1	1	1

[19]	Freeze ref	Freezes actual reference. The frozen reference is now the point of enable/condition for Speed up and Speed down to be used. If Speed up/down is used, the speed change always follows ramp 2 (par. 3-51 and 3-52) in the range 0 - par. 3-03 <i>Maximum Reference</i> .
------	------------	---

[20]	Freeze output	Freezes actual motor frequency (Hz). The frozen motor frequency is now the point of enable/condition for Speed up and Speed down to be used. If Speed up/down is used, the speed change always follows ramp 2 (par. 3-51 and 3-52) in the range 0 - par. 1-23 <i>Motor Frequency</i> .
------	---------------	--



**NB!**  
When Freeze output is active, the frequency converter cannot be stopped via a low 'start [13]' signal. Stop the frequency converter via a terminal programmed for Coasting inverse [2] or Coast and reset, inverse [3].

[21]	Speed up	For digital control of the up/down speed is desired (motor potentiometer). Activate this function by selecting either Freeze reference or Freeze output. When Speed up is activated for less than 400 msec. the resulting reference will be increased by 0.1 %. If Speed up is activated for more than 400 msec. the resulting reference will ramp according to Ramp 1 in par. 3-41.
------	----------	--

[22]	Speed down	Same as Speed up [21].
------	------------	------------------------

[23]	Set-up select bit 0	Selects one of the four set-ups. Set par. 0-10 <i>Active Set-up</i> to Multi Set-up.
------	---------------------	--

[24]	Set-up select bit 1	Same as Set-up select bit 0 [23]. (Default Digital input 32)
------	---------------------	---

[32]	Pulse input	Select Pulse input when using a pulse sequence as either reference or feedback. Scaling is done in par. group 5-5*.
------	-------------	---

[34]	Ramp bit 0	Select which ramp to use. Logic "0" will select ramp 1 while logic "1" will select ramp 2.
------	------------	--

[36]	Mains failure inverse	Activates par. 14-10 <i>Mains Failure</i> . Mains failure inverse is active in the Logic "0" situation.
------	-----------------------	---

[52]	Run Permissive	The input terminal, for which the Run permissive has been programmed must be logic "1" before a start command can be accepted. Run permissive has a logic 'AND' function related to the terminal which is programmed for <i>START</i> [8], <i>Jog</i> [14] or <i>Freeze Output</i> [20], which means that in order to start running the motor, both conditions must be fulfilled. If Run Permissive is programmed on multiple terminals, Run permissive needs only be logic '1' on one of the terminals for the function to be carried out. The digital output signal for Run Request ( <i>Start</i> [8], <i>Jog</i> [14] or <i>Freeze output</i> [20]) programmed in par. 5-3* Digital outputs, or par. 5-4* Relays, will not be affected by Run Permissive.
------	----------------	---

[53]	Hand start	A signal applied will put the frequency converter into Hand mode as if button <i>Hand On</i> on the LCP has been pressed and a normal stop command will be overridden. If disconnecting the signal, the motor will stop. To make any other start commands valid, another digital input must be assign to <i>Auto Start</i> and a signal applied to this. The <i>Hand On</i> and <i>Auto On</i> buttons on the LCP has no impact. The <i>Off</i> button on the LCP will override <i>Hand Start</i> and <i>Auto Start</i> . Press either the <i>Hand On</i> or <i>Auto On</i> button to make <i>Hand Start</i> and <i>Auto Start</i> active again. If no signal on neither <i>Hand Start</i> nor <i>Auto Start</i> , the motor will stop regardless of any normal Start command applied. If signal applied to both <i>Hand Start</i> and <i>Auto Start</i> , the function will be <i>Auto Start</i> . If pressing the <i>Off</i> button on the LCP the motor will stop regardless of signals on <i>Hand Start</i> and <i>Auto Start</i> .
------	------------	---

[54]	Auto start	A signal applied will put the frequency converter into Auto mode as if the LCP button <i>Auto On</i> has been pressed. See also <i>Hand Start</i> [53]
[55]	DigiPot Increase	Uses the input as an INCREASE signal to the Digital Potentiometer function described in parameter group 3-9*
[56]	DigiPot Decrease	Uses the input as a DECREASE signal to the Digital Potentiometer function described in parameter group 3-9*
[57]	DigiPot Clear	Uses the input to CLEAR the Digital Potentiometer reference described in parameter group 3-9*
[60]	Counter A (up)	(Terminal 29 or 33 only) Input for increment counting in the SLC counter.
[61]	Counter A (down)	(Terminal 29 or 33 only) Input for decrement counting in the SLC counter.
[62]	Reset Counter A	Input for reset of counter A.
[63]	Counter B (up)	(Terminal 29 and 33 only) Input for increment counting in the SLC counter.
[64]	Counter B (down)	(Terminal 29 and 33 only) Input for decrement counting in the SLC counter.
[65]	Reset Counter B	Input for reset of counter B.
[66]	Sleep Mode	Forces frequency converter into Sleep Mode (see par. 22-4*, Sleep Mode). Reacts on the rising edge of signal applied!
[78]	Reset Preventive Maintenance Word	Resets all data in par. 16-96, Preventive Maintenance Word, to 0.

The below setting options are all related to the Cascade Controller. Wiring diagrams and settings for parameter, see group 25-\*\* for more details.

[120]	Lead Pump Start	Starts/Stops the Lead Pump (controlled by the frequency converter). A start requires that also a System Start signal has been applied e.g. to one of the digital inputs set for <i>Start</i> [8]!
[121]	Lead Pump Alternation	Forces alternation of the lead pump in a Cascade Controller. <i>Lead Pump Alternation</i> , par. 25-50, must be set to either <i>At Command</i> [2] or <i>At Staging or At Command</i> [3]. <i>Alternation Event</i> , par. 25-51, can be set to any of the four options.

[130 - 138] Pump1 Interlock - Pump9 Interlock The function will depend on the setting in par. 25-06, Number of Pumps. If set to *No* [0], then Pump1 refers to the pump controlled by relay RELAY1 etc. If set to *Yes* [1], Pump1 refers to the pump controlled by the frequency converter only (without any of the build in relays involved) and Pump2 to the pump controlled by the relay RELAY1. Variable speed pump (lead) cannot be interlocked in the basic Cascade Controller.  
See below table:

Setting in Par. 5-1*	Setting in Par. 25-06	
	[0] No	[1] Yes
[130] Pump1 Interlock	Controlled by RELAY1 (only if not lead pump)	Frequency Converter controlled (cannot be interlocked)
[131] Pump2 Interlock	Controlled by RELAY2	Controlled by RELAY1
[132] Pump3 Interlock	Controlled by RELAY3	Controlled by RELAY2
[133] Pump4 Interlock	Controlled by RELAY4	Controlled by RELAY3
[134] Pump5 Interlock	Controlled by RELAY5	Controlled by RELAY4
[135] Pump6 Interlock	Controlled by RELAY6	Controlled by RELAY5
[136] Pump7 Interlock	Controlled by RELAY7	Controlled by RELAY6
[137] Pump8 Interlock	Controlled by RELAY8	Controlled by RELAY7
[138] Pump9 Interlock	Controlled by RELAY9	Controlled by RELAY8

### 5-13 Terminal 29 Digital Input

**Option:**

[0] \* No Operation

**Function:**

Same options and functions as par. 5-1\* *Digital Inputs*.

### 5-14 Terminal 32 Digital Input

**Option:**

[0] \* No operation

**Function:**

Same options and functions as par. 5-1\*, except for *Pulse input*.

[1] Reset

[2]	Coast inverse
[3]	Coast and reset inv
[5]	DC-brake inverse
[6]	Stop inverse
[7]	External interlock
[8]	Start
[9]	Latched start
[10]	Reversing
[11]	Start reversing
[14]	Jog
[15]	Preset reference on
[16]	Preset ref bit 0
[17]	Preset ref bit 1
[18]	Preset ref bit 2
[19]	Freeze reference
[20]	Freeze output
[21]	Speed up
[22]	Speed down
[23]	Set-up select bit 0
[24]	Set-up select bit 1
[34]	Ramp bit 0
[36]	Mains failure inverse
[37]	Fire Mode
[52]	Run permissive
[53]	Hand start
[54]	Auto start
[55]	DigiPot increase
[56]	DigiPot decrease
[57]	DigiPot clear
[62]	Reset Counter A
[65]	Reset Counter B
[66]	Sleep Mode
[78]	Reset Maint. Word
[120]	Lead Pump Start
[121]	Lead Pump Alternation
[130]	Pump 1 Interlock
[131]	Pump 2 Interlock
[132]	Pump 3 Interlock

**5-15 Terminal 33 Digital Input**

<b>Option:</b>	<b>Function:</b>
	Same options and functions as par. 5-1* Digital Inputs.
[0] *	No operation

**5-30 Terminal 27 Digital Output**

<b>Option:</b>	<b>Function:</b>
	Same options and functions as par. 5-3*.
[0] *	No operation



## 5-40 Function Relay

Array [8]

(Relay 1 [0], Relay 2 [1], Relay 7 [6], Relay 8 [7], Relay 9 [8])

Select options to define the function of the relays.

The selection of each mechanical relay is realized in an array parameter.

[0] *	No Operation
[1]	Control Ready
[2]	Drive Ready
[3]	Drive Ready/Remote
[4]	Stand-by/No Warning
[5]	Running
[6]	Running/No Warning
[8]	Run on Ref./No Warning
[9]	Alarm
[10]	Alarm or Warning
[11]	At Torque Limit
[12]	Out of Current Range
[13]	Below Current, low
[14]	Above Current, high
[15]	Out of Speed Range
[16]	Below Speed, low
[17]	Above Speed, high
[18]	Out of Feedb. Range
[19]	Below Feedback, low
[20]	Above Feedback, high
[21]	Thermal Warning
[25]	Reverse
[26]	Bus OK
[27]	Torque Limit & Stop
[28]	Brake, No Warning
[29]	Brake Ready, No Fault
[30]	Brake Fault (IGBT)
[35]	External Interlock
[36]	Control Word Bit 11
[37]	Control Word Bit 12
[40]	Out of Ref. Range
[41]	Below Reference, low
[42]	Above Ref. high
[45]	Bus ctrl
[46]	Bus ctrl, 1 if timeout
[47]	Bus ctrl, 0 if timeout
[60]	Comparator 0
[61]	Comparator 1
[62]	Comparator 2
[63]	Comparator 3
[64]	Comparator 4

[65]	Comparator 5
[70]	Logic Rule 0
[71]	Logic Rule 1
[72]	Logic Rule 2
[73]	Logic Rule 3
[74]	Logic Rule 4
[75]	Logic Rule 5
[80]	SL Digital Output A
[81]	SL Digital Output B
[82]	SL Digital Output C
[83]	SL Digital Output D
[84]	SL Digital Output E
[85]	SL Digital Output F
[160]	No Alarm
[161]	Running Reverse
[165]	Local Ref. Active
[166]	Remote Ref. Active
[167]	Start Cmd. Active
[168]	Drive in Hand Mode
[169]	Drive in Auto Mode
[180]	Clock Fault
[181]	Prev. Maintenance
[190]	No-Flow
[191]	Dry Pump
[192]	End of Curve
[193]	Sleep Mode
[194]	Broken Belt
[195]	Bypass Valve Control
[199]	Pipe Filling
[211]	Cascade Pump1
[212]	Cascade Pump2
[213]	Cascade Pump3
[223]	Alarm, Trip Locked
[224]	Bypass Mode Active

## 8

**5-53 Term. 29 High Ref./Feedb. Value****Range:**100.000 N/ [-999999.999 - 999999.999 N/A]  
A\***Function:**Enter the high reference value [RPM] for the motor shaft speed and the high feedback value, see also par. 5-58 *Term. 33 High Ref./Feedb. Value.***8.2.8 6-\*\* Analog In/Out**

Parameter group for configuration of the analog input and output.

**6-00 Live Zero Timeout Time**

**Range:**

10 s\* [1 - 99 s]

**Function:**

Enter the Live Zero Time-out time period. Live Zero Time-out Time is active for analog inputs, i.e. terminal 53 or terminal 54, used as reference or feedback sources. If the reference signal value associated with the selected current input falls below 50% of the value set in par. 6-10 *Terminal 53 Low Voltage*, par. 6-12 *Terminal 53 Low Current*, par. 6-20 *Terminal 54 Low Voltage* or par. 6-22 *Terminal 54 Low Current* for a time period longer than the time set in par. 6-00 *Live Zero Timeout Time*, the function selected in par. 6-01 *Live Zero Timeout Function* will be activated.

**6-01 Live Zero Timeout Function**

**Option:**

**Function:**

Select the time-out function. The function set in par. 6-01 *Live Zero Timeout Function* will be activated if the input signal on terminal 53 or 54 is below 50% of the value in par. 6-10 *Terminal 53 Low Voltage*, par. 6-12 *Terminal 53 Low Current*, par. 6-20 *Terminal 54 Low Voltage* or par. 6-22 *Terminal 54 Low Current* for a time period defined in par. 6-00 *Live Zero Timeout Time*. If several time-outs occur simultaneously, the frequency converter prioritises the time-out functions as follows:

1. par. 6-01 *Live Zero Timeout Function*
2. par. 8-04 *Control Timeout Function*

The output frequency of the frequency converter can be:

- [1] frozen at the present value
- [2] overruled to stop
- [3] overruled to jog speed
- [4] overruled to max. speed
- [5] overruled to stop with subsequent trip

[0] \* Off

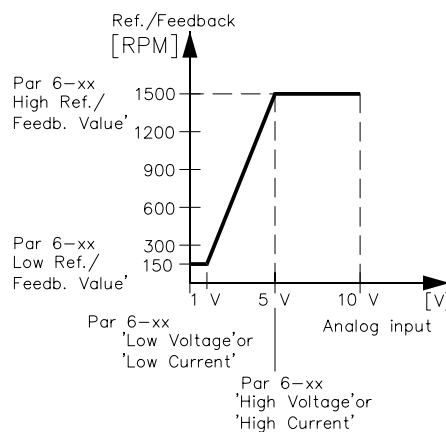
[1] Freeze output

[2] Stop

[3] Jogging

[4] Max. speed

[5] Stop and trip



**6-10 Terminal 53 Low Voltage****Range:**

0.07 V\* [0.00 - par. 6-11 V]

**Function:**Enter the low voltage value. This analog input scaling value should correspond to the low reference/feedback value set in par. 6-14 *Terminal 53 Low Ref./Feedb. Value*.**6-11 Terminal 53 High Voltage****Range:**

10.00 V\* [par. 6-10 - 10.00 V]

**Function:**Enter the high voltage value. This analog input scaling value should correspond to the high reference/feedback value set in par. 6-15 *Terminal 53 High Ref./Feedb. Value*.**6-14 Terminal 53 Low Ref./Feedb. Value****Range:**

0.000 N/A\* [-999999.999 - 999999.999 N/A]

**Function:**Enter the analog input scaling value that corresponds to the low voltage/low current set in par. 6-10 *Terminal 53 Low Voltage* and par. 6-12 *Terminal 53 Low Current*.**6-15 Terminal 53 High Ref./Feedb. Value****Range:**

50.000 N/A\* [-999999.999 - 999999.999 N/A]

**Function:**Enter the analog input scaling value that corresponds to the high voltage/high current value set in par. 6-11 *Terminal 53 High Voltage* and par. 6-13 *Terminal 53 High Current*.**6-20 Terminal 54 Low Voltage****Range:**

0.07 V\* [0.00 - par. 6-21 V]

**Function:**Enter the low voltage value. This analog input scaling value should correspond to the low reference/feedback value, set in par. 6-24 *Terminal 54 Low Ref./Feedb. Value*.**6-21 Terminal 54 High Voltage****Range:**

10.00 V\* [par. 6-20 - 10.00 V]

**Function:**Enter the high voltage value. This analog input scaling value should correspond to the high reference/feedback value set in par. 6-25 *Terminal 54 High Ref./Feedb. Value*.**6-24 Terminal 54 Low Ref./Feedb. Value****Range:**

0.000 N/A\* [-999999.999 - 999999.999 N/A]

**Function:**Enter the analog input scaling value that corresponds to the low voltage/low current value set in par. 6-20 *Terminal 54 Low Voltage* and par. 6-22 *Terminal 54 Low Current*.**6-25 Terminal 54 High Ref./Feedb. Value****Range:**

100.000 N/A\* [-999999.999 - 999999.999 N/A]

**Function:**Enter the analog input scaling value that corresponds to the high voltage/high current value set in par. 6-21 *Terminal 54 High Voltage* and par. 6-23 *Terminal 54 High Current*.**6-50 Terminal 42 Output****Option:**

[0] \* No operation

**Function:**Select the function of Terminal 42 as an analog current output. A motor current of 20 mA corresponds to  $I_{max}$ .

[100] Output freq. 0-100

: 0 - 100 Hz, (0-20 mA)

[101] Reference Min-Max

: Minimum reference - Maximum reference, (0-20 mA)

[102] Feedback +-200%

: -200% to +200% of par. 20-14, (0-20 mA)

[103] Motor cur. 0-Imax

: 0 - Inverter Max. Current (par. 16-37), (0-20 mA)

[104] Torque 0-Tlim

: 0 - Torque limit (par. 4-16), (0-20 mA)

[105]	Torque 0-Tnom	: 0 - Motor rated torque, (0-20 mA)
[106]	Power 0-Pnom	: 0 - Motor rated power, (0-20 mA)
[107]	Speed 0-HighLim	: 0 - Speed High Limit (par. 4-13 and par. 4-14), (0-20 mA)
[113]	Ext. Closed Loop 1	: 0 - 100%, (0-20 mA)
[114]	Ext. Closed Loop 2	: 0 - 100%, (0-20 mA)
[115]	Ext. Closed Loop 3	: 0 - 100%, (0-20 mA)
[130]	Out frq 0-100 4-20mA	: 0 - 100 Hz
[131]	Reference 4-20mA	: Minimum Reference - Maximum Reference
[132]	Feedback 4-20mA	: -200% to +200% of par. 20-14 <i>Maximum Reference/Feedb.</i>
[133]	Motor cur. 4-20mA	: 0 - Inverter Max. Current (par. 16-37 <i>Inv. Max. Current</i> )
[134]	Torq.0-lim 4-20 mA	: 0 - Torque limit (par. 4-16)
[135]	Torq.0-nom 4-20mA	: 0 - Motor rated torque
[136]	Power 4-20mA	: 0 - Motor rated power
[137]	Speed 4-20mA	: 0 - Speed High Limit (4-13 and 4-14)
[139]	Bus ctrl.	: 0 - 100%, (0-20 mA)
[140]	Bus ctrl. 4-20 mA	: 0 - 100%
[141]	Bus ctrl t.o.	: 0 - 100%, (0-20 mA)
[142]	Bus ctrl t.o. 4-20mA	: 0 - 100%
[143]	Ext. CL 1 4-20mA	: 0 - 100%
[144]	Ext. CL 2 4-20mA	: 0 - 100%
[145]	Ext. CL 3 4-20mA	: 0 - 100%

**NB!**

Values for setting the Minimum Reference is found in open loop par. 3-02 *Minimum Reference* and for closed loop par. 20-13 *Minimum Reference/Feedb.* - values for maximum reference for open loop is found in par. 3-03 *Maximum Reference* and for closed loop par. 20-14 *Maximum Reference/Feedb.*

**6-51 Terminal 42 Output Min Scale**

**Range:**

0.00 %\* [0.00 - 200.00 %]

**Function:**

Scale for the minimum output (0 or 4 mA) of the analogue signal at terminal 42. Set the value to be the **percentage** of the full range of the variable selected in par. 6-50 *Terminal 42 Output*.

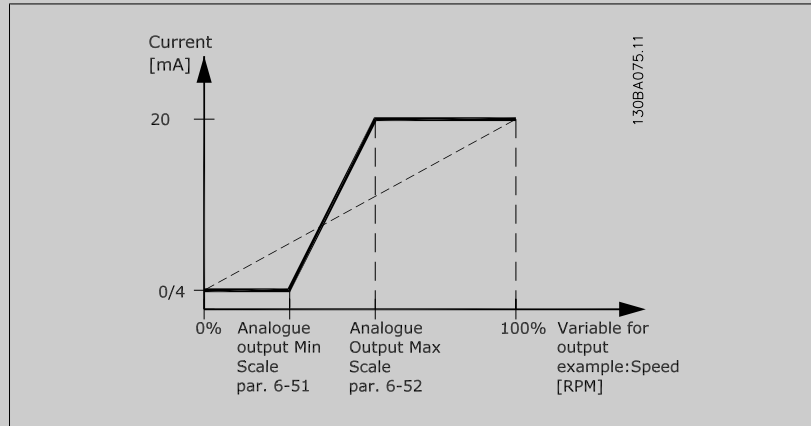
**6-52 Terminal 42 Output Max Scale**

**Range:**

100.00 %\* [0.00 - 200.00 %]

**Function:**

Scale for the maximum output (20 mA) of the analog signal at terminal 42.  
Set the value to be the percentage of the full range of the variable selected in par. 6-50 *Terminal 42 Output*.



It is possible to get a value lower than 20 mA at full scale by programming values >100% by using a formula as follows:

$$20 \text{ mA} \mid \text{desired maximum current} \times 100 \%$$

$$\text{i.e. } 10 \text{ mA} : \frac{20 \text{ mA}}{10 \text{ mA}} \times 100 \% = 200 \%$$

8

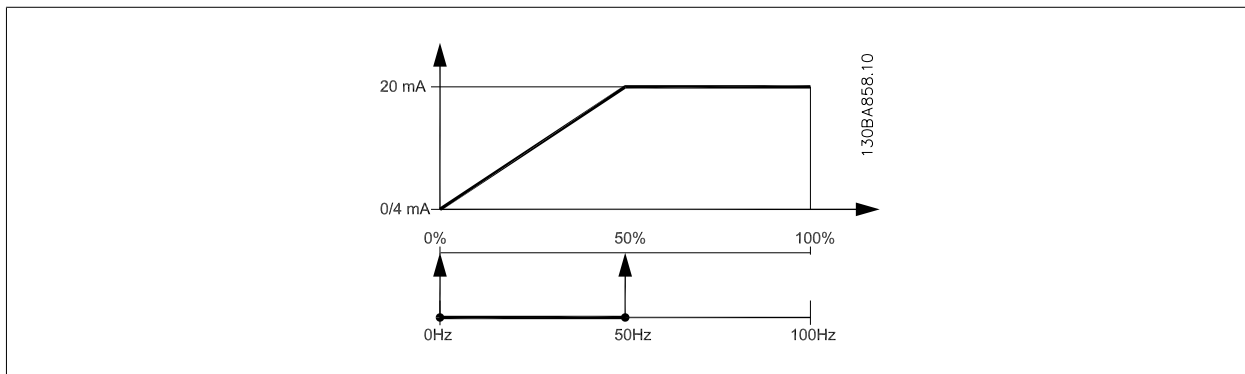
**EXAMPLE 1:**

Variable value= OUTPUT FREQUENCY, range = 0-100 Hz

Range needed for output = 0-50 Hz

Output signal 0 or 4 mA is needed at 0 Hz (0% of range) - set par. 6-51 *Terminal 42 Output Min Scale* to 0%

Output signal 20 mA is needed at 50 Hz (50% of range) - set par. 6-52 *Terminal 42 Output Max Scale* to 50%



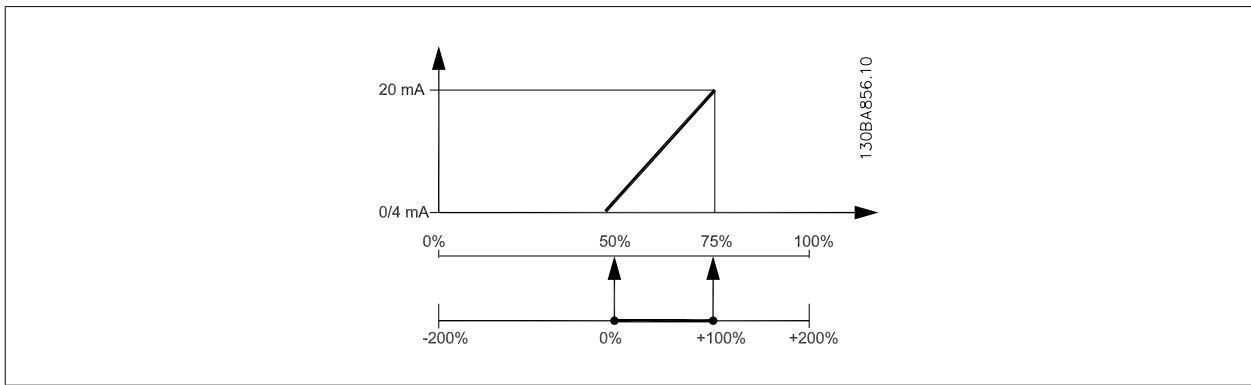
**EXAMPLE 2:**

Variable= FEEDBACK, range= -200% to +200%

Range needed for output= 0-100%

Output signal 0 or 4 mA is needed at 0% (50% of range) - set par. 6-51 *Terminal 42 Output Min Scale* to 50%

Output signal 20 mA is needed at 100% (75% of range) - set par. 6-52 *Terminal 42 Output Max Scale* to 75%



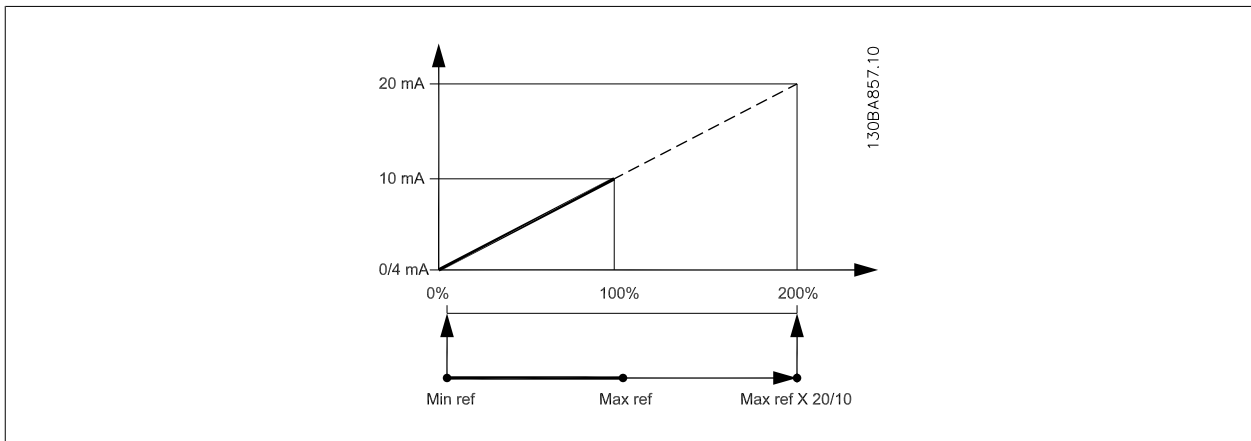
**EXAMPLE 3:**

Variable value= REFERENCE, range= Min ref - Max ref

Range needed for output= Min ref (0%) - Max ref (100%), 0-10 mA

Output signal 0 or 4 mA is needed at Min ref - set par. 6-51 *Terminal 42 Output Min Scale* to 0%

Output signal 10 mA is needed at Max ref (100% of range) - set par. 6-52 *Terminal 42 Output Max Scale* to 200% (20 mA / 10 mA x 100%=200%).



**8.2.9 Drive Closed Loop, 20-\*\***

This parameter group is used for configuring the closed loop PID Controller, that controls the output frequency of the frequency converter.

**20-12 Reference/Feedback Unit**

Option:	Function:
[0] None	
[1] *	%
[5]	PPM
[10]	1/min
[11]	RPM
[12]	Pulse/s
[20]	l/s
[21]	l/min
[22]	l/h
[23]	m <sup>3</sup> /s
[24]	m <sup>3</sup> /min
[25]	m <sup>3</sup> /h

[30]	kg/s	
[31]	kg/min	
[32]	kg/h	
[33]	t/min	
[34]	t/h	
[40]	m/s	
[41]	m/min	
[45]	m	
[60]	°C	
[70]	mbar	
[71]	bar	
[72]	Pa	
[73]	kPa	
[74]	m WG	
[75]	mm Hg	
[80]	kW	
[120]	GPM	
[121]	gal/s	
[122]	gal/min	
[123]	gal/h	
[124]	CFM	
[125]	ft <sup>3</sup> /s	
[126]	ft <sup>3</sup> /min	
[127]	ft <sup>3</sup> /h	
[130]	lb/s	
[131]	lb/min	
[132]	lb/h	
[140]	ft/s	
[141]	ft/min	
[145]	ft	
[160]	°F	
[170]	psi	
[171]	lb/in <sup>2</sup>	
[172]	in WG	
[173]	ft WG	
[174]	in Hg	
[180]	HP	This parameter determines the unit that is used for the setpoint reference and feedback that the PID Controller will use for controlling the output frequency of the frequency converter.

### 20-21 Setpoint 1

**Range:**

0.000 Proc- [-999999.999 - 999999.999 Proc-  
essCtrlU- essCtrlUnit]  
nit\*

**Function:**

Setpoint 1 is used in Closed Loop Mode to enter a setpoint reference that is used by the frequency converter's PID Controller. See the description of par. 20-20 *Feedback Function*.



**NB!**

Setpoint reference entered here is added to any other references that are enabled (see par. group 3-1\*).



### 20-81 PID Normal/Inverse Control

**Option:**

[0] \* Normal

[1] Inverse

**Function:**

*Normal* [0] causes the frequency converter's output frequency to decrease when the feedback is greater than the setpoint reference. This is common for pressure-controlled supply fan and pump applications.

*Inverse* [1] causes the frequency converter's output frequency to increase when the feedback is greater than the setpoint reference.

### 20-82 PID Start Speed [RPM]

**Range:**

0 RPM\* [0 - par. 4-13 RPM]

**Function:**

When the frequency converter is first started, it initially ramps up to this output speed in Open Loop Mode, following the active Ramp Up Time. When the output speed programmed here is reached, the frequency converter will automatically switch to Closed Loop Mode and the PID Controller will begin to function. This is useful in applications in which the driven load must first quickly accelerate to a minimum speed when it is started.



**NB!**

This parameter will only be visible if par. 0-02 *Motor Speed Unit* is set to [0], RPM.

### 20-93 PID Proportional Gain

**Range:**

0.50 N/A\* [0.00 - 10.00 N/A]

**Function:**

If (Error x Gain) jumps with a value equal to what is set in par. 20-14 *Maximum Reference/Feedb.* the PID controller will try to change the output speed equal to what is set in par. 4-13 *Motor Speed High Limit [RPM]*/par. 4-14 *Motor Speed High Limit [Hz]* but in practice of course limited by this setting. The proportional band (error causing output to change from 0-100%) can be calculated by means of the formula:

$$\left( \frac{1}{\text{Proportional Gain}} \right) \times (\text{Max Reference})$$

**NB!**

Always set the desired for par. 20-14 *Maximum Reference/Feedb.* before setting the values for the PID controller in par. group 20-9\*.

### 20-94 PID Integral Time

**Range:**

20.00 s\* [0.01 - 10000.00 s]

**Function:**

Over time, the integrator accumulates a contribution to the output from the PID controller as long as there is a deviation between the Reference/Setpoint and feedback signals. The contribution is proportional to the size of the deviation. This ensures that the deviation (error) approaches zero. Quick response on any deviation is obtained when the integral time is set to a low value. Setting it too low, however, may cause the control to become unstable.

The value set, is the time needed for the integrator to add the same contribution as the proportional part for a certain deviation.

If the value is set to 10,000, the controller will act as a pure proportional controller with a P-band based on the value set in par. 20-93 *PID Proportional Gain*. When no deviation is present, the output from the proportional controller will be 0.

## 8.2.10 22-\*\* Miscellaneous

This group contains parameters used for monitoring water/ wastewater applications.

### 22-20 Low Power Auto Set-up

Option:	Function:
[0] * Off	When set for <i>Enabled</i> , an auto set up sequence is activated, automatically setting speed to approx. 50 and 85% of rated motor speed (par. 4-13 <i>Motor Speed High Limit [RPM]</i> , par. 4-14 <i>Motor Speed High Limit [Hz]</i> ). At those two speeds, the power consumption is automatically measured and stored. Before enabling Auto Set Up: <ol style="list-style-type: none"> <li>1. Close valve(s) in order to create a no flow condition</li> <li>2. The frequency converter must be set for Open Loop (par. 1-00 <i>Configuration Mode</i>). Note that it is important also to set par. 1-03 <i>Torque Characteristics</i>.</li> </ol>
[1] Enabled	



**NB!**  
Auto Set Up must be done when the system has reached normal operating temperature!



**NB!**  
It is important that the par. 4-13 *Motor Speed High Limit [RPM]* or par. 4-14 *Motor Speed High Limit [Hz]* is set to the max. operational speed of the motor!  
It is important to do the Auto Set-up before configuring the integrated PI Controller as settings will be reset when changing from Closed to Open Loop in par. 1-00 *Configuration Mode*.



**NB!**  
Carry out the tuning with the same settings in par. 1-03 *Torque Characteristics*, as for operation after the tuning.

### 22-21 Low Power Detection

Option:	Function:
[0] * Disabled	If selecting Enabled, the Low Power Detection commissioning must be carried out in order to set the parameters in group 22-3* for proper operation!
[1] Enabled	

### 22-22 Low Speed Detection

Option:	Function:
[0] * Disabled	Select Enabled for detecting when the motor operates with a speed as set in par. 4-11 <i>Motor Speed Low Limit [RPM]</i> or par. 4-12 <i>Motor Speed Low Limit [Hz]</i> .
[1] Enabled	

### 22-23 No-Flow Function

Option:	Function:
[0] * Off	Common actions for Low Power Detection and Low Speed Detection (Individual selections not possible).
[1] Sleep Mode	
[2] Warning	Messages in the Local Control Panel display (if mounted) and/or signal via a relay or a digital output.
[3] Alarm	The frequency converter trips and motor stays stopped until reset.

### 22-24 No-Flow Delay

**Range:**

10 s\* [1 - 600 s]

**Function:**

Set the time Low Power/Low Speed must stay detected to activate signal for actions. If detection disappears before run out of the timer, the timer will be reset.

### 22-26 Dry Pump Function

**Option:**

[0] \* Off

[1] Warning

[2] Alarm

**Function:**

*Low Power Detection* must be Enabled (par. 22-21 *Low Power Detection*) and commissioned (using either par. 22-3\*, *No Flow Power Tuning*, or par. 22-20 *Low Power Auto Set-up*) in order to use Dry Pump Detection.

Messages in the Local Control Panel display (if mounted) and/or signal via a relay or a digital output.

The frequency converter trips and motor stays stopped until reset.

### 22-27 Dry Pump Delay

**Range:**

10 s\* [0 - 600 s]

**Function:**

Defines for how long the Dry Pump condition must be active before activating Warning or Alarm

### 22-30 No-Flow Power

**Range:**

0.00 kW\* [0.00 - 0.00 kW]

**Function:**

Read out of calculated No Flow power at actual speed. If power drops to the display value the frequency converter will consider the condition as a No Flow situation.

### 22-31 Power Correction Factor

**Range:**

100 %\* [1 - 400 %]

**Function:**

Make corrections to the calculated power at par. 22-30 *No-Flow Power*.

If No Flow is detected, when it should not be detected, the setting should be decreased. However, if No Flow is not detected, when it should be detected, the setting should be increased to above 100%.

### 22-32 Low Speed [RPM]

**Range:**

0 RPM\* [0 - par. 22-36 RPM]

**Function:**

To be used if par. 0-02 *Motor Speed Unit* has been set for RPM (parameter not visible if Hz selected). Set used speed for the 50% level.

This function is used for storing values needed to tune No Flow Detection.

### 22-33 Low Speed [Hz]

**Range:**

0 Hz\* [0.0 - par. 22-37 Hz]

**Function:**

To be used if par. 0-02 *Motor Speed Unit* has been set for Hz (parameter not visible if RPM selected). Set used speed for the 50% level.

The function is used for storing values needed to tune No Flow Detection.

### 22-34 Low Speed Power [kW]

**Range:**

0 kW\* [0.00 - 0.00 kW]

**Function:**

To be used if par. 0-03 *Regional Settings* has been set for International (parameter not visible if North America selected).

Set power consumption at 50% speed level.

This function is used for storing values needed to tune No Flow Detection.

**22-35 Low Speed Power [HP]****Range:**

0 hp\* [0.00 - 0.00 hp]

**Function:**

To be used if par. 0-03 *Regional Settings* has been set for North America (parameter not visible if International selected).

Set power consumption at 50% speed level.

This function is used for storing values needed to tune No Flow Detection.

**22-36 High Speed [RPM]****Range:**

0 RPM\* [0 - par. 4-13 RPM]

**Function:**

To be used if par. 0-02 *Motor Speed Unit* has been set for RPM (parameter not visible if Hz selected).

Set used speed for the 85% level.

The function is used for storing values needed to tune No Flow Detection.

**22-37 High Speed [Hz]****Range:**

0.0 Hz\* [0.0 - par. 4-14 Hz]

**Function:**

To be used if par. 0-02 *Motor Speed Unit* has been set for Hz (parameter not visible if RPM selected).

Set used speed for the 85% level.

The function is used for storing values needed to tune No Flow Detection.

**22-38 High Speed Power [kW]****Range:**

0 kW\* [0.00 - 0.00 kW]

**Function:**

To be used if par. 0-03 *Regional Settings* has been set for International (parameter not visible if North America selected).

Set power consumption at 85% speed level.

This function is used for storing values needed to tune No Flow Detection.

**22-39 High Speed Power [HP]****Range:**

0 hp\* [0.00 - 0.00 hp]

**Function:**

To be used if par. 0-03 *Regional Settings* has been set for North America (parameter not visible if International selected).

Set power consumption at 85% speed level.

This function is used for storing values needed to tune No Flow Detection.

**22-40 Minimum Run Time****Range:**

10 s\* [0 - 600 s]

**Function:**

Set the desired minimum running time for the motor after a start command (digital input or Bus) before entering Sleep Mode.

**22-41 Minimum Sleep Time****Range:**

10 s\* [0 - 600 s]

**Function:**

Set the desired Minimum Time for staying in Sleep Mode. This will override any wake up conditions.

**22-42 Wake-up Speed [RPM]****Range:**

0 RPM\* [par. 4-11 - par. 4-13 RPM]

**Function:**

To be used if par. 0-02 *Motor Speed Unit* has been set for RPM (parameter not visible if Hz selected).

Only to be used if par. 1-00 *Configuration Mode* is set for Open Loop and speed reference is applied by an external controller.

Set the reference speed at which the Sleep Mode should be cancelled.

### 22-43 Wake-up Speed [Hz]

**Range:**

0 Hz\* [par. 4-12 - par. 4-14 Hz]

**Function:**

To be used if par. 0-02 *Motor Speed Unit*, has been set for Hz (parameter not visible if RPM selected). Only to be used if par. 1-00 *Configuration Mode*, is set for Open Loop and speed reference is applied by an external controller controlling the pressure.  
Set the reference speed at which the Sleep Mode should be cancelled.

### 22-44 Wake-up Ref./FB Difference

**Range:**

10%\* [0-100%]

**Function:**

Only to be used if par. 1-00, *Configuration Mode*, is set for Closed Loop and the integrated PI controller is used for controlling the pressure.  
Set the pressure drop allowed in percentage of set point for the pressure (Pset) before cancelling the Sleep Mode.



**NB!**

If used in application where the integrated PI controller is set for inverse control in par. 20-71, *PID, Normal/Inverse Control*, the value set in par. 22-44 will automatically be added.

### 22-45 Setpoint Boost

**Range:**

0 %\* [-100 - 100 %]

**Function:**

Only to be used if par. 1-00 *Configuration Mode*, is set for Closed Loop and the integrated PI controller is used. In systems with e.g. constant pressure control, it is advantageous to increase the system pressure before the motor is stopped. This will extend the time in which the motor is stopped and help to avoid frequent start/stop.  
Set the desired over pressure/temperature in percentage of set point for the pressure (Pset)/temperature before entering the Sleep Mode.  
If setting for 5%, the boost pressure will be Pset\*1.05. The negative values can be used for e.g. cooling tower control where a negative change is needed.

### 22-46 Maximum Boost Time

**Range:**

60 s\* [0 - 600 s]

**Function:**

Only to be used if par. 1-00 *Configuration Mode* is set for Closed Loop and the integrated PI controller is used for controlling the pressure.  
Set the maximum time for which boost mode will be allowed. If the set time is exceeded, Sleep Mode will be entered, not waiting for the set boost pressure to be reached.

### 22-50 End of Curve Function

**Option:**

[0] \* Off

**Function:**

End of Curve monitoring not active.

[1] Warning

A warning is issued in the display [W94].

[2] Alarm

An alarm is issued and the frequency converter trips. A message [A94] appears in the display.



**NB!**

Automatic restart will reset the alarm and start the system again.

### 22-51 End of Curve Delay

**Range:**

10 s\* [0 - 600 s]

**Function:**

When an End of Curve condition is detected, a timer is activated. When the time set in this parameter expires, and the End of Curve condition has been steady in the entire period, the function set in par. 22-50 *End of Curve Function* will be activated. If the condition disappears before the timer expires, the timer will be reset.

**22-80 Flow Compensation**

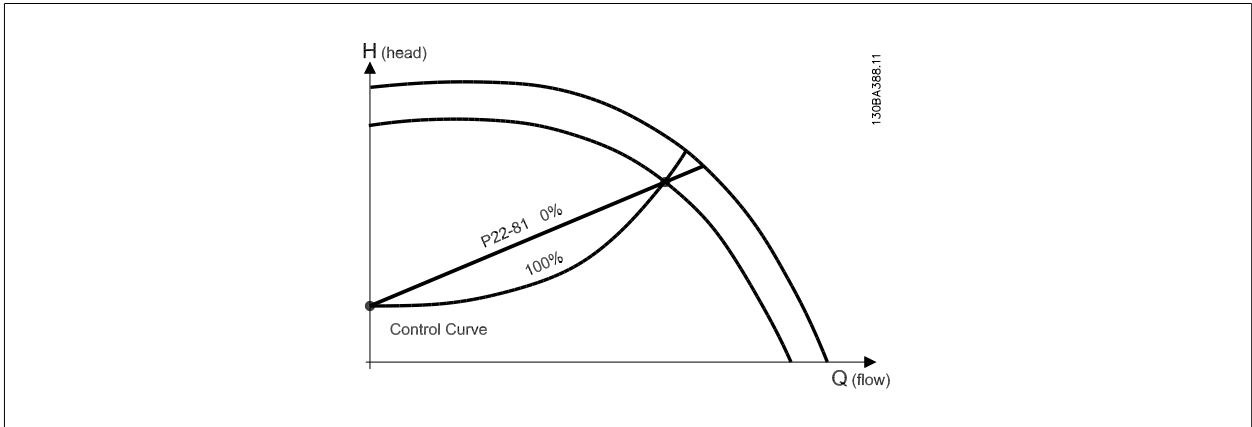
Option:	Function:
[0] * Disabled	[0] <i>Disabled:</i> Set-Point compensation not active.
[1] Enabled	[1] <i>Enabled:</i> Set-Point compensation is active. Enabling this parameter allows the Flow Compensated Setpoint operation.

**22-81 Square-linear Curve Approximation**

Range:	Function:
100 %* [0 - 100 %]	<p><b>Example 1:</b> Adjustment of this parameter allows the shape of the control curve to be adjusted. 0 = Linear 100% = Ideal shape (theoretical).</p>

 **NB!**  
Please note: Not visible when running in cascade.

8

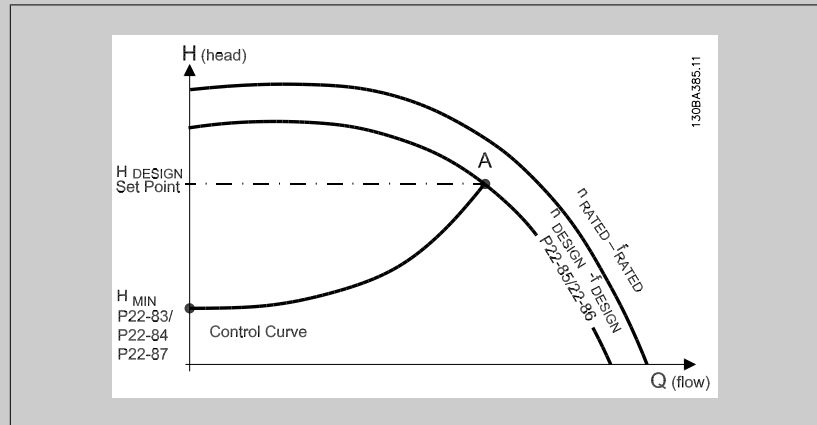


**22-82 Work Point Calculation**

**Option:**

**Function:**

**Example 1:** Speed at System Design Working Point is known:

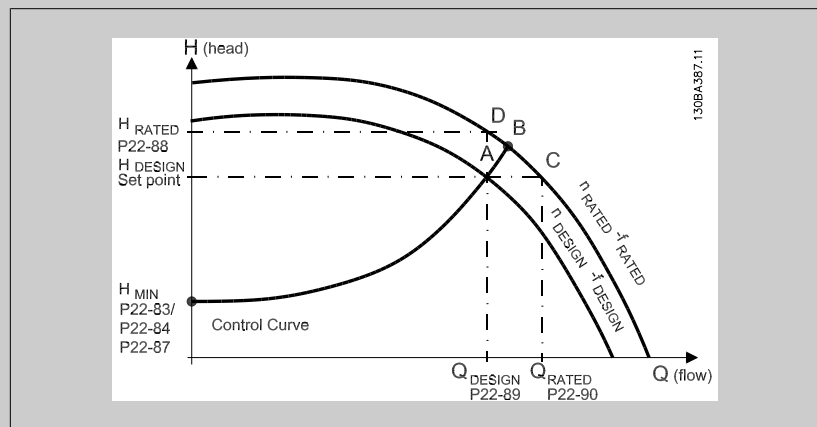


From the data sheet showing characteristics for the specific equipment at different speeds, simply reading across from the  $H_{DESIGN}$  point and the  $Q_{DESIGN}$  point allows us to find point A, which is the System Design Working Point. The pump characteristics at this point should be identified and the associated speed programmed. Closing the valves and adjusting the speed until  $H_{MIN}$  has been achieved allows the speed at the no flow point to be identified.

Adjustment of par. 22-81 *Square-linear Curve Approximation* then allows the shape of the control curve to be adjusted infinitely.

**Example 2:**

Speed at System Design Working Point is not known: Where the Speed at System Design Working Point is unknown, another reference point on the control curve needs to be determined by means of the data sheet. By looking at the curve for the rated speed and plotting the design pressure ( $H_{DESIGN}$ , Point C) the flow at that pressure  $Q_{RATED}$  can be determined. Similarly, by plotting the design flow ( $Q_{DESIGN}$ , Point D), the pressure  $H_D$  at that flow can be determined. Knowing these two points on the pump curve, along with  $H_{MIN}$  as described above, allows the frequency converter to calculate the reference point B and thus to plot the control curve which will also include the System design Working Point A.



[0] \* Disabled

*Disabled [0]:* Work Point Calculation not active. To be used if speed at design point is known (see table above).

[1] Enabled

*Enabled [1]:* Work Point Calculation is active. Enabling this parameter allows the calculation of the unknown System Design Working Point at 50/60 Hz speed, from the input data set in par. 22-83 *Speed at No-Flow [RPM]*, par. 22-84 *Speed at No-Flow [Hz]*, par. 22-87 *Pressure at No-Flow Speed*, par. 22-88 *Pressure at Rated Speed*, par. 22-89 *Flow at Design Point* and par. 22-90 *Flow at Rated Speed*.

**22-84 Speed at No-Flow [Hz]****Range:**

50.0 Hz\* [0.0 - par. 22-86 Hz]

**Function:**

Resolution 0.033 Hz.

The speed of the motor at which flow has effectively stopped and minimum pressure  $H_{MIN}$  is achieved should be entered here in Hz. Alternatively, the speed in RPM can be entered in par. 22-83 *Speed at No-Flow [RPM]*. If it has been decided to use Hz in par. 0-02 *Motor Speed Unit* then par. 22-86 *Speed at Design Point [Hz]* should also be used. Closing the valves and reducing the speed until minimum pressure  $H_{MIN}$  is achieved will determine this value.

**22-85 Speed at Design Point [RPM]****Range:**

1500. RPM\* [par. 22-83 - 60000. RPM]

**Function:**

Resolution 1 RPM.

Only visible when par. 22-82 *Work Point Calculation* is set to *Disable*. The speed of the motor at which the System Design Working Point is achieved should be entered here in RPM. Alternatively, the speed in Hz can be entered in par. 22-86 *Speed at Design Point [Hz]*. If it has been decided to use RPM in par. 0-02 *Motor Speed Unit* then par. 22-83 *Speed at No-Flow [RPM]* should also be used.

**22-86 Speed at Design Point [Hz]****Range:**

50/60.0 Hz\* [par. 22-84 - par. 4-19 Hz]

**Function:**

Resolution 0.033 Hz.

Only visible when par. 22-82 *Work Point Calculation* is set to *Disable*. The speed of the motor at which the System Design Working Point is achieved should be entered here in Hz. Alternatively, the speed in RPM can be entered in par. 22-85 *Speed at Design Point [RPM]*. If it has been decided to use Hz in par. 0-02 *Motor Speed Unit*, then par. 22-83 *Speed at No-Flow [RPM]* should also be used.

**22-87 Pressure at No-Flow Speed****Range:**

0.000 N/A\* [0.000 - par. 22-88 N/A]

**Function:**Enter the pressure  $H_{MIN}$  corresponding to Speed at No Flow in Reference/Feedback Units.**22-88 Pressure at Rated Speed****Range:**

999999.999 N/A\* [par. 22-87 - 999999.999 N/A]

**Function:**

Enter the value corresponding to the Pressure at Rated Speed, in Reference/Feedback Units. This value can be defined using the pump datasheet.

**22-83 Speed at No-Flow [RPM]****Range:**

300. RPM\* [0 - par. 22-85 RPM]

**Function:**

Resolution 1 RPM.

The speed of the motor at which flow is zero and minimum pressure  $H_{MIN}$  is achieved should be entered here in RPM. Alternatively, the speed in Hz can be entered in par. 22-84 *Speed at No-Flow [Hz]*. If it has been decided to use RPM in par. 0-02 *Motor Speed Unit* then par. 22-85 *Speed at Design Point [RPM]* should also be used. Closing the valves and reducing the speed until minimum pressure  $H_{MIN}$  is achieved will determine this value.

**22-90 Flow at Rated Speed****Range:**

0.000 N/A\* [0.000 - 999999.999 N/A]

**Function:**


Enter the value corresponding to Flow at Rated Speed. This value can be defined using the pump datasheet.




### 8.2.11 23-0\* Timed Actions

Use *Timed Actions* for actions needing to be performed on a daily or weekly basis, e.g. different references for working hours / non-working hours. Up to 10 Timed Actions can be programmed in the frequency converter. The Timed Action number is selected from the list when entering parameter group 23-0\* from the LCP. par. 23-00 *ON Time* – par. 23-04 *Occurrence* then refer to the selected Timed Action number. Each Timed Action is divided into an ON time and an OFF time, in which two different actions may be performed.

The actions programmed in Timed Actions are merged with corresponding actions from digital inputs, control work via bus and Smart Logic Controller, according to merge rules set up in 8-5\*, Digital/Bus.



**NB!**  
The clock (parameter group 0-7\*) must be correctly programmed for Timed Actions to function correctly.



**NB!**  
When mounting an Analog I/O MCB109 option card, a battery back up of the date and time is included.

**NB!**  
The PC-based Configuration Tool MCT 10 comprise a special guide for easy programming of Timed Actions.

#### 23-00 ON Time


Array [10]

**Range:**

0 N/A\* [0 - 0 N/A]

**Function:**

Sets the ON time for the Timed Action.



**NB!**  
The frequency converter has no back up of the clock function and the set date/ time will reset to default (2000-01-01 00:00) after a power down unless a Real Time Clock module with back up is installed. In par. 0-79 *Clock Fault* it is possible to program for a Warning in case clock has not been set properly, e.g. after a power down.

#### 23-01 ON Action

Arra [10]

**Option:**

**Function:**

Select the action during ON Time. See par. 13-52 *SL Controller Action* for descriptions of the options.

[0] *	Disabled
[1]	No action
[2]	Select set-up 1
[3]	Select set-up 2
[4]	Select set-up 3
[5]	Select set-up 4
[10]	Select preset ref 0
[11]	Select preset ref 1
[12]	Select preset ref 2
[13]	Select preset ref 3
[14]	Select preset ref 4
[15]	Select preset ref 5

[16]	Select preset ref 6
[17]	Select preset ref 7
[18]	Select ramp 1
[19]	Select ramp 2
[22]	Run
[23]	Run reverse
[24]	Stop
[26]	DC Brake
[27]	Coast
[28]	Freeze output
[29]	Start timer 0
[30]	Start timer 1
[31]	Start timer 2
[32]	Set digital out A low
[33]	Set digital out B low
[34]	Set digital out C low
[35]	Set digital out D low
[36]	Set digital out E low
[37]	Set digital out F low
[38]	Set digital out A high
[39]	Set digital out B high
[40]	Set digital out C high
[41]	Set digital out D high
[42]	Set digital out E high
[43]	Set digital out F high
[60]	Reset Counter A
[61]	Reset Counter B
[70]	Start Timer 3
[71]	Start Timer 4
[72]	Start Timer 5
[73]	Start Timer 6
[74]	Start Timer 7

**NB!**

For choices [32] - [43], see also par. group 5-3\*, *Digital Outputs* and 5-4\*, *Relays*.

**23-02 OFF Time**

Array [10]

**Range:**

0 N/A\* [0 - 0 N/A]

**Function:**

Sets the OFF time for the Timed Action.



**NB!**

The frequency converter has no back up of the clock function and the set date/time will reset to default (2000-01-01 00:00) after a power down unless a Real Time Clock module with back up is installed. In par. 0-79 *Clock Fault* it is possible to program for a Warning in case clock has not been set properly, e.g. after a power down.

### 23-03 OFF Action

Array [10]

**Option:**

**Function:**

Select the action during OFF Time. See par. 13-52 *SL Controller Action* for descriptions of the options.

- [0] \* Disabled
- [1] No action
- [2] Select set-up 1
- [3] Select set-up 2
- [4] Select set-up 3
- [5] Select set-up 4
- [10] Select preset ref 0
- [11] Select preset ref 1
- [12] Select preset ref 2
- [13] Select preset ref 3
- [14] Select preset ref 4
- [15] Select preset ref 5
- [16] Select preset ref 6
- [17] Select preset ref 7
- [18] Select ramp 1
- [19] Select ramp 2
- [22] Run
- [23] Run reverse
- [24] Stop
- [26] DC Brake
- [27] Coast
- [28] Freeze output
- [29] Start timer 0
- [30] Start timer 1
- [31] Start timer 2
- [32] Set digital out A low
- [33] Set digital out B low
- [34] Set digital out C low
- [35] Set digital out D low
- [36] Set digital out E low
- [37] Set digital out F low
- [38] Set digital out A high
- [39] Set digital out B high
- [40] Set digital out C high
- [41] Set digital out D high
- [42] Set digital out E high
- [43] Set digital out F high
- [60] Reset Counter A
- [61] Reset Counter B
- [70] Start Timer 3
- [71] Start Timer 4
- [72] Start Timer 5

[73] Start Timer 6

[74] Start Timer 7

**23-04 Occurrence**

Array [10]

**Option:****Function:**

Select which day(s) the Timed Action applies to. Specify working/non-working days in par. 0-81 *Working Days*, par. 0-82 *Additional Working Days* and par. 0-83 *Additional Non-Working Days*.

[0] \* All days

[1] Working days

[2] Non-working days

[3] Monday

[4] Tuesday

[5] Wednesday

[6] Thursday

[7] Friday

[8] Saturday

[9] Sunday

## 8

**8.2.12 Water Application Functions, 29-\*\***

The group contains parameters used for monitoring water / wastewater applications.

**29-00 Pipe Fill Enable****Option:****Function:**

[0] \* Disabled

Select Enabled to fill pipes at a user specified rate.

[1] Enabled

Select Enabled to fill pipes with a user specified rate.

**29-01 Pipe Fill Speed [RPM]****Range:****Function:**

Speed Low [Speed Low Limit - Speed High Limit\* it]

Set the filling speed for filling horizontal pipe systems. The speed can be selected in Hz or RPM depending on the choices made in par. 4-11 / par. 4-13 (RPM) or in par. 4-12 / par. 4-14 (Hz).

**29-02 Pipe Fill Speed [Hz]****Range:****Function:**Motor [Speed Low Limit - Speed High Limit\* it]  
Speed Low it]  
Limit\*

Set the filling speed for filling horizontal pipe systems. The speed can be selected in Hz or RPM depending on the choices made in par. 4-11 / par. 4-13 (RPM) or in par. 4-12 / par. 4-14 (Hz).

**29-03 Pipe Fill Time****Range:****Function:**

0 s\* [0 - 3600 s]

Set the specified time for pipe filling of horizontal pipe systems.

**29-04 Pipe Fill Rate****Range:****Function:**0.001 units/ [0.001 – 999999.999 units/s]  
s\*

Specifies the filling rate in units/second using the PI controller. Filling rate units are feedback units/second. This function is used for filling-up vertical pipe systems but will be active when the filling-time has expired, no matter what, until the pipe fill-set-point set in par. 29-05 is reached.

### 29-05 Filled Setpoint

**Range:**

0 s\* [0 – 999999,999 s]

**Function:**

Specifies the Filled Set-point at which the Pipe Fill Function will be disabled and the PID controller will take control. This function can be used both for horizontal and vertical pipe systems.

## 8.3 Parameter Options

### 8.3.1 Default settings

Changes during operation:

"TRUE" means that the parameter can be changed while the frequency converter is in operation and "FALSE" means that the frequency converter must be stopped before a change can be made.

4-Set-up:

'All set-up': the parameter can be set individually in each of the four set-ups, i. e. one single parameter can have four different data values.

'1 set-up': data value will be the same in all set-ups.

SR:

Size related

N/A:

No default value available.

Conversion index:

This number refers to a conversion figure used when writing or reading by means of a frequency converter.

<b>Conv. index</b>	100	67	6	5	4	3	2	1	0	-1	-2	-3	-4	-5	-6
<b>Conv. factor</b>	1	1/60	1000000	100000	10000	1000	100	10	1	0.1	0.01	0.001	0.0001	0.00001	0.000001

Data type	Description	Type
2	Integer 8	Int8
3	Integer 16	Int16
4	Integer 32	Int32
5	Unsigned 8	UInt8
6	Unsigned 16	UInt16
7	Unsigned 32	UInt32
9	Visible String	VisStr
33	Normalized value 2 bytes	N2
35	Bit sequence of 16 boolean variables	V2
54	Time difference w/o date	TimD

### 8.3.2 Operation/Display 0-\*\*-\*

Par. No. #	Parameter description	Default value	4-set-up	Change during operation	Conversion index	Type
<b>0-0* Basic Settings</b>						
0-01	Language	[0] English	1 set-up	TRUE	-	Uint8
0-02	Motor Speed Unit	[0] RPM	2 set-ups	FALSE	-	Uint8
0-03	Regional Settings	[0] International	2 set-ups	FALSE	-	Uint8
0-04	Operating State at Power-up	[0] Resume	All set-ups	TRUE	-	Uint8
0-05	Local Mode Unit	[0] As Motor Speed Unit	2 set-ups	FALSE	-	Uint8
<b>0-1* Set-up Operations</b>						
0-10	Active Set-up	[1] Set-up 1	1 set-up	TRUE	-	Uint8
0-11	Programming Set-up	[9] Active Set-up	All set-ups	TRUE	-	Uint8
0-12	This Set-up Linked to	[0] Not linked	All set-ups	FALSE	-	Uint8
0-13	Readout: Linked Set-ups	0 N/A	All set-ups	FALSE	0	Uint16
0-14	Readout: Prog. Set-ups / Channel	0 N/A	All set-ups	TRUE	0	Int32
<b>0-2* LCP Display</b>						
0-20	Display Line 1.1 Small	1601	All set-ups	TRUE	-	Uint16
0-21	Display Line 1.2 Small	1662	All set-ups	TRUE	-	Uint16
0-22	Display Line 1.3 Small	1614	All set-ups	TRUE	-	Uint16
0-23	Display Line 2 Large	1613	All set-ups	TRUE	-	Uint16
0-24	Display Line 3 Large	1652	All set-ups	TRUE	-	Uint16
0-25	My Personal Menu	SR	1 set-up	TRUE	0	Uint16
<b>0-3* LCP Custom Readout</b>						
0-30	Custom Readout Unit	[1] %	All set-ups	TRUE	-	Uint8
0-31	Custom Readout Min Value	SR	All set-ups	TRUE	-2	Int32
0-32	Custom Readout Max Value	100.00 CustomReadoutUnit	All set-ups	TRUE	-2	Int32
0-37	Display Text 1	0 N/A	1 set-up	TRUE	0	VisStr[25]
0-38	Display Text 2	0 N/A	1 set-up	TRUE	0	VisStr[25]
0-39	Display Text 3	0 N/A	1 set-up	TRUE	0	VisStr[25]
<b>0-4* LCP Keypad</b>						
0-40	[Hand on] Key on LCP	[1] Enabled	All set-ups	TRUE	-	Uint8
0-41	[Off] Key on LCP	[1] Enabled	All set-ups	TRUE	-	Uint8
0-42	[Auto on] Key on LCP	[1] Enabled	All set-ups	TRUE	-	Uint8
0-43	[Reset] Key on LCP	[1] Enabled	All set-ups	TRUE	-	Uint8
0-44	[Off/Reset] Key on LCP	[1] Enabled	All set-ups	TRUE	-	Uint8
0-45	[Drive Bypass] Key on LCP	[1] Enabled	All set-ups	TRUE	-	Uint8
<b>0-5* Copy/Save</b>						
0-50	LCP Copy	[0] No copy	All set-ups	FALSE	-	Uint8
0-51	Set-up Copy	[0] No copy	All set-ups	FALSE	-	Uint8

Par. No. #	Parameter description	Default value	4-set-up	Change during operation	Conversion index	Type
<b>0-6* Password</b>						
0-60	Main Menu Password	100 N/A	1 set-up	TRUE	0	UInt16
0-61	Access to Main Menu w/o Password	[0] Full access	1 set-up	TRUE	-	UInt8
0-65	Personal Menu Password	200 N/A	1 set-up	TRUE	0	UInt16
0-66	Access to Personal Menu w/o Password	[0] Full access	1 set-up	TRUE	-	UInt8
<b>0-7* Clock Settings</b>						
0-70	Date and Time	SR	All set-ups	TRUE	0	TimeOfDay
0-71	Date Format	[0] YYYY-MM-DD	1 set-up	TRUE	-	UInt8
0-72	Time Format	[0] 24 h	1 set-up	TRUE	-	UInt8
0-74	DST/Summertime	[0] Off	1 set-up	TRUE	-	UInt8
0-76	DST/Summertime Start	SR	1 set-up	TRUE	0	TimeOfDay
0-77	DST/Summertime End	SR	1 set-up	TRUE	0	TimeOfDay
0-79	Clock Fault	null	1 set-up	TRUE	-	UInt8
0-81	Working Days	null	1 set-up	TRUE	-	UInt8
0-82	Additional Working Days	SR	1 set-up	TRUE	0	TimeOfDay
0-83	Additional Non-Working Days	SR	1 set-up	TRUE	0	TimeOfDay
0-89	Date and Time Readout	0 N/A	All set-ups	TRUE	0	VisStr[25]



### 8.3.3 Load/Motor 1-1-\*

Par. No. #	Parameter description	Default value	4-set-up	Change during operation	Conversion index	Type
<b>1-0* General Settings</b>						
1-00	Configuration Mode	null	All set-ups	TRUE	-	Uint8
1-01	Motor Control Principle	null	All set-ups	FALSE	-	Uint8
1-03	Torque Characteristics	[3] Auto Energy Optim. VT	All set-ups	TRUE	-	Uint8
<b>1-1* Motor Selection</b>						
1-10	Motor Construction	[0] Asynchron	All set-ups	FALSE	-	Uint8
<b>1-2* Motor Data</b>						
1-20	Motor Power [kW]	SR	All set-ups	FALSE	1	Uint32
1-21	Motor Power [HP]	SR	All set-ups	FALSE	-2	Uint32
1-22	Motor Voltage	SR	All set-ups	FALSE	0	Uint16
1-23	Motor Frequency	SR	All set-ups	FALSE	0	Uint16
1-24	Motor Current	SR	All set-ups	FALSE	-2	Uint32
1-25	Motor Nominal Speed	SR	All set-ups	FALSE	67	Uint16
1-28	Motor Rotation Check	[0] Off	All set-ups	FALSE	-	Uint8
1-29	Automatic Motor Adaptation (AMA)	[0] Off	All set-ups	FALSE	-	Uint8
<b>1-3* Adv. Motor Data</b>						
1-30	Stator Resistance (Rs)	SR	All set-ups	FALSE	-4	Uint32
1-31	Rotor Resistance (Rr)	SR	All set-ups	FALSE	-4	Uint32
1-32	Stator Reactance (Xs)	SR	All set-ups	FALSE	-4	Uint32
1-33	Stator Leakage Reactance (X1)	SR	All set-ups	FALSE	-4	Uint32
1-34	Rotor Leakage Reactance (X2)	SR	All set-ups	FALSE	-4	Uint32
1-35	Main Reactance (Xh)	SR	All set-ups	FALSE	-4	Uint32
1-36	Iron Loss Resistance (Rfe)	SR	All set-ups	FALSE	-3	Uint32
1-39	Motor Poles	SR	All set-ups	FALSE	0	Uint8
<b>1-5* Load Indep. Setting</b>						
1-50	Motor Magnetisation at Zero Speed	100 %	All set-ups	TRUE	0	Uint16
1-51	Min Speed Normal Magnetising [RPM]	SR	All set-ups	TRUE	67	Uint16
1-52	Min Speed Normal Magnetising [Hz]	SR	All set-ups	TRUE	-1	Uint16
1-55	V/f Characteristic - V	SR	All set-ups	TRUE	-1	Uint16
1-56	V/f Characteristic - f	SR	All set-ups	TRUE	-1	Uint16
<b>1-6* Load Depen. Setting</b>						
1-60	Low Speed Load Compensation	100 %	All set-ups	TRUE	0	Int16
1-61	High Speed Load Compensation	100 %	All set-ups	TRUE	0	Int16
1-62	Slip Compensation	0 %	All set-ups	TRUE	0	Int16
1-63	Slip Compensation Time Constant	SR	All set-ups	TRUE	-2	Uint16
1-64	Resonance Dampening	100 %	All set-ups	TRUE	0	Uint16
1-65	Resonance Dampening Time Constant	5 ms	All set-ups	TRUE	-3	Uint8
<b>1-7* Start Adjustments</b>						
1-71	Start Delay	0.0 s	All set-ups	TRUE	-1	Uint16
1-73	Flying Start	[0] Disabled	All set-ups	FALSE	-	Uint8
1-74	Start Speed [RPM]	SR	All set-ups	TRUE	67	Uint16
1-75	Start Speed [Hz]	SR	All set-ups	TRUE	-1	Uint16
1-76	Start Current	0.00 A	All set-ups	TRUE	-2	Uint32

Par. No. #	Parameter description	Default value	4-set-up	Change during operation	Conversion index	Type
<b>1-8* Stop Adjustments</b>						
1-80	Function at Stop	[0] Coast	All set-ups	TRUE	-	Uint8
1-81	Min Speed for Function at Stop [RPM]	SR	All set-ups	TRUE	67	Uint16
1-82	Min Speed for Function at Stop [Hz]	SR	All set-ups	TRUE	-1	Uint16
1-86	Trip Speed Low [RPM]	0 RPM	All set-ups	TRUE	67	Uint16
1-87	Trip Speed Low [Hz]	0 Hz	All set-ups	TRUE	-1	Uint16
<b>1-9* Motor Temperature</b>						
1-90	Motor Thermal Protection	[4] ETR trip 1	All set-ups	TRUE	-	Uint8
1-91	Motor External Fan	[0] No	All set-ups	TRUE	-	Uint16
1-93	Thermistor Source	[0] None	All set-ups	TRUE	-	Uint8

### 8.3.4 Brakes 2-\*\*

Par. No. #	Parameter description	Default value	4-set-up	Change during operation	Conversion index	Type
<b>2-0* DC-Brake</b>						
2-00	DC Hold/Preheat Current	50 %	All set-ups	TRUE	0	Uint8
2-01	DC Brake Current	50 %	All set-ups	TRUE	0	Uint16
2-02	DC Braking Time	10.0 s	All set-ups	TRUE	-1	Uint16
2-03	DC Brake Cut In Speed [RPM]	SR	All set-ups	TRUE	67	Uint16
2-04	DC Brake Cut In Speed [Hz]	SR	All set-ups	TRUE	-1	Uint16
<b>2-1* Brake Energy Funct.</b>						
2-10	Brake Function	[0] Off	All set-ups	TRUE	-	Uint8
2-11	Brake Resistor (ohm)	SR	All set-ups	TRUE	0	Uint16
2-12	Brake Power Limit (kW)	SR	All set-ups	TRUE	0	Uint32
2-13	Brake Power Monitoring	[0] Off	All set-ups	TRUE	-	Uint8
2-15	Brake Check	[0] Off	All set-ups	TRUE	-	Uint8
2-16	AC brake Max. Current	100.0 %	All set-ups	TRUE	-1	Uint32
2-17	Over-voltage Control	[2] Enabled	All set-ups	TRUE	-	Uint8

### 8.3.5 Reference / Ramps 3-\*\*-\*

Par. No. #	Parameter description	Default value	4-set-up	Change during operation	Conversion index	Type
<b>3-0* Reference Limits</b>						
3-02	Minimum Reference	SR	All set-ups	TRUE	-3	Int32
3-03	Maximum Reference	SR	All set-ups	TRUE	-3	Int32
3-04	Reference Function	[0] Sum	All set-ups	TRUE	-	UInt8
<b>3-1* References</b>						
3-10	Preset Reference	0.00 %	All set-ups	TRUE	-2	Int16
3-11	Jog Speed [Hz]	SR	All set-ups	TRUE	-1	UInt16
3-13	Reference Site	[0] Linked to Hand / Auto	All set-ups	TRUE	-	UInt8
3-14	Preset Relative Reference	0.00 %	All set-ups	TRUE	-2	Int32
3-15	Reference 1 Source	[1] Analog input 53	All set-ups	TRUE	-	UInt8
3-16	Reference 2 Source	[0] No function	All set-ups	TRUE	-	UInt8
3-17	Reference 3 Source	[0] No function	All set-ups	TRUE	-	UInt8
3-19	Jog Speed [RPM]	SR	All set-ups	TRUE	67	UInt16
<b>3-4* Ramp 1</b>						
3-41	Ramp 1 Ramp Up Time	SR	All set-ups	TRUE	-2	UInt32
3-42	Ramp 1 Ramp Down Time	SR	All set-ups	TRUE	-2	UInt32
<b>3-5* Ramp 2</b>						
3-51	Ramp 2 Ramp Up Time	SR	All set-ups	TRUE	-2	UInt32
3-52	Ramp 2 Ramp Down Time	SR	All set-ups	TRUE	-2	UInt32
<b>3-8* Other Ramps</b>						
3-80	Jog Ramp Time	SR	All set-ups	TRUE	-2	UInt32
3-81	Quick Stop Ramp Time	SR	2 set-ups	TRUE	-2	UInt32
3-84	Initial Ramp Time	0.00 s	All set-ups	TRUE	-2	UInt16
3-85	Check Valve Ramp Time	0.00 s	All set-ups	TRUE	-2	UInt16
3-86	Check Valve Ramp End Speed [RPM]	SR	All set-ups	TRUE	67	UInt16
3-87	Check Valve Ramp End Speed [Hz]	SR	All set-ups	TRUE	-1	UInt16
3-88	Final Ramp Time	0.00 s	All set-ups	TRUE	-2	UInt16
<b>3-9* Digital Pot.Meter</b>						
3-90	Step Size	0.10 %	All set-ups	TRUE	-2	UInt16
3-91	Ramp Time	1.00 s	All set-ups	TRUE	-2	UInt32
3-92	Power Restore	[0] Off	All set-ups	TRUE	-	UInt8
3-93	Maximum Limit	100 %	All set-ups	TRUE	0	Int16
3-94	Minimum Limit	0 %	All set-ups	TRUE	0	Int16
3-95	Ramp Delay	SR	All set-ups	TRUE	-3	TimD

### 8.3.6 Limits / Warnings 4-\*\*

Par. No. #	Parameter description	Default value	4-set-up	Change during operation	Conversion index	Type
<b>4-1* Motor Limits</b>						
4-10	Motor Speed Direction	[0] Clockwise	All set-ups	FALSE	-	UInt8
4-11	Motor Speed Low Limit [RPM]	SR	All set-ups	TRUE	67	UInt16
4-12	Motor Speed Low Limit [Hz]	SR	All set-ups	TRUE	-1	UInt16
4-13	Motor Speed High Limit [RPM]	SR	All set-ups	TRUE	67	UInt16
4-14	Motor Speed High Limit [Hz]	SR	All set-ups	TRUE	-1	UInt16
4-16	Torque Limit Motor Mode	SR	All set-ups	TRUE	-1	UInt16
4-17	Torque Limit Generator Mode	100.0 %	All set-ups	TRUE	-1	UInt16
4-18	Current Limit	SR	All set-ups	TRUE	-1	UInt32
4-19	Max Output Frequency	SR	All set-ups	FALSE	-1	UInt16
<b>4-5* Adj. Warnings</b>						
4-50	Warning Current Low	0.00 A	All set-ups	TRUE	-2	UInt32
4-51	Warning Current High	ImaxVLT (P1637)	All set-ups	TRUE	-2	UInt32
4-52	Warning Speed Low	0 RPM	All set-ups	TRUE	67	UInt16
4-53	Warning Speed High	outputSpeedHighLimit (P413)	All set-ups	TRUE	67	UInt16
4-54	Warning Reference Low	-999999.999 N/A	All set-ups	TRUE	-3	Int32
4-55	Warning Reference High	999999.999 N/A	All set-ups	TRUE	-3	Int32
4-56	Warning Feedback Low	-999999.999 ReferenceFeedbackUnit	All set-ups	TRUE	-3	Int32
4-57	Warning Feedback High	999999.999 ReferenceFeedbackUnit	All set-ups	TRUE	-3	Int32
4-58	Missing Motor Phase Function	[2] Trip 1000 ms	All set-ups	TRUE	-	UInt8
<b>4-6* Speed Bypass</b>						
4-60	Bypass Speed From [RPM]	SR	All set-ups	TRUE	67	UInt16
4-61	Bypass Speed From [Hz]	SR	All set-ups	TRUE	-1	UInt16
4-62	Bypass Speed To [RPM]	SR	All set-ups	TRUE	67	UInt16
4-63	Bypass Speed To [Hz]	SR	All set-ups	TRUE	-1	UInt16
4-64	Semi-Auto Bypass Set-up	[0] Off	All set-ups	FALSE	-	UInt8

### 8.3.7 Digital In/Out 5-\*\*\*

Par. No. #	Parameter description	Default value	4-set-up	Change during operation	Conversion index	Type
<b>5-0* Digital I/O mode</b>						
5-00	Digital I/O Mode	[0] PNP - Active at 24V	All set-ups	FALSE	-	Uint8
5-01	Terminal 27 Mode	[0] Input	All set-ups	TRUE	-	Uint8
5-02	Terminal 29 Mode	[0] Input	All set-ups	TRUE	-	Uint8
<b>5-1* Digital Inputs</b>						
5-10	Terminal 18 Digital Input	[8] Start	All set-ups	TRUE	-	Uint8
5-11	Terminal 19 Digital Input	[0] No operation	All set-ups	TRUE	-	Uint8
5-12	Terminal 27 Digital Input	null	All set-ups	TRUE	-	Uint8
5-13	Terminal 29 Digital Input	[0] No operation	All set-ups	TRUE	-	Uint8
5-14	Terminal 32 Digital Input	[0] No operation	All set-ups	TRUE	-	Uint8
5-15	Terminal 33 Digital Input	[0] No operation	All set-ups	TRUE	-	Uint8
5-16	Terminal X30/2 Digital Input	[0] No operation	All set-ups	TRUE	-	Uint8
5-17	Terminal X30/3 Digital Input	[0] No operation	All set-ups	TRUE	-	Uint8
5-18	Terminal X30/4 Digital Input	[0] No operation	All set-ups	TRUE	-	Uint8
<b>5-3* Digital Outputs</b>						
5-30	Terminal 27 Digital Output	[0] No operation	All set-ups	TRUE	-	Uint8
5-31	Terminal 29 Digital Output	[0] No operation	All set-ups	TRUE	-	Uint8
5-32	Term X30/6 Digi Out (MCB 101)	[0] No operation	All set-ups	TRUE	-	Uint8
5-33	Term X30/7 Digi Out (MCB 101)	[0] No operation	All set-ups	TRUE	-	Uint8
<b>5-4* Relays</b>						
5-40	Function Relay	null	All set-ups	TRUE	-	Uint8
5-41	On Delay, Relay	0.01 s	All set-ups	TRUE	-2	Uint16
5-42	Off Delay, Relay	0.01 s	All set-ups	TRUE	-2	Uint16
<b>5-5* Pulse Input</b>						
5-50	Term. 29 Low Frequency	100 Hz	All set-ups	TRUE	0	Uint32
5-51	Term. 29 High Frequency	100 Hz	All set-ups	TRUE	0	Uint32
5-52	Term. 29 Low Ref./Feedb. Value	0.000 N/A	All set-ups	TRUE	-3	Int32
5-53	Term. 29 High Ref./Feedb. Value	100.000 N/A	All set-ups	TRUE	-3	Int32
5-54	Pulse Filter Time Constant #29	100 ms	All set-ups	FALSE	-3	Uint16
5-55	Term. 33 Low Frequency	100 Hz	All set-ups	TRUE	0	Uint32
5-56	Term. 33 High Frequency	100 Hz	All set-ups	TRUE	0	Uint32
5-57	Term. 33 Low Ref./Feedb. Value	0.000 N/A	All set-ups	TRUE	-3	Int32
5-58	Term. 33 High Ref./Feedb. Value	100.000 N/A	All set-ups	TRUE	-3	Int32
5-59	Pulse Filter Time Constant #33	100 ms	All set-ups	FALSE	-3	Uint16
<b>5-6* Pulse Output</b>						
5-60	Terminal 27 Pulse Output Variable	[0] No operation	All set-ups	TRUE	-	Uint8
5-62	Pulse Output Max Freq #27	5000 Hz	All set-ups	TRUE	0	Uint32
5-63	Terminal 29 Pulse Output Variable	[0] No operation	All set-ups	TRUE	-	Uint8
5-65	Pulse Output Max Freq #29	5000 Hz	All set-ups	TRUE	0	Uint32
5-66	Terminal X30/6 Pulse Output Variable	[0] No operation	All set-ups	TRUE	-	Uint8
5-68	Pulse Output Max Freq #X30/6	5000 Hz	All set-ups	TRUE	0	Uint32
<b>5-9* Bus Controlled</b>						
5-90	Digital & Relay Bus Control	0 N/A	All set-ups	TRUE	0	Uint32
5-93	Pulse Out #27 Bus Control	0.00 %	All set-ups	TRUE	-2	N2
5-94	Pulse Out #27 Timeout Preset	0.00 %	1 set-up	TRUE	-2	Uint16
5-95	Pulse Out #29 Bus Control	0.00 %	All set-ups	TRUE	-2	N2
5-96	Pulse Out #29 Timeout Preset	0.00 %	1 set-up	TRUE	-2	Uint16
5-97	Pulse Out #X30/6 Bus Control	0.00 %	All set-ups	TRUE	-2	N2
5-98	Pulse Out #X30/6 Timeout Preset	0.00 %	1 set-up	TRUE	-2	Uint16

### 8.3.8 Analog In/Out 6-\*\*

Par. No. #	Parameter description	Default value	4-set-up	Change during operation	Conversion index	Type
<b>6-0* Analog I/O Mode</b>						
6-00	Live Zero Timeout Time	10 s	All set-ups	TRUE	0	Uint8
6-01	Live Zero Timeout Function	[0] Off	All set-ups	TRUE	-	Uint8
<b>6-1* Analog Input 53</b>						
6-10	Terminal 53 Low Voltage	0.07 V	All set-ups	TRUE	-2	Int16
6-11	Terminal 53 High Voltage	10.00 V	All set-ups	TRUE	-2	Int16
6-12	Terminal 53 Low Current	4.00 mA	All set-ups	TRUE	-5	Int16
6-13	Terminal 53 High Current	20.00 mA	All set-ups	TRUE	-5	Int16
6-14	Terminal 53 Low Ref./Feedb. Value	0.000 N/A	All set-ups	TRUE	-3	Int32
6-15	Terminal 53 High Ref./Feedb. Value	SR	All set-ups	TRUE	-3	Int32
6-16	Terminal 53 Filter Time Constant	0.001 s	All set-ups	TRUE	-3	Uint16
6-17	Terminal 53 Live Zero	[1] Enabled	All set-ups	TRUE	-	Uint8
<b>6-2* Analog Input 54</b>						
6-20	Terminal 54 Low Voltage	0.07 V	All set-ups	TRUE	-2	Int16
6-21	Terminal 54 High Voltage	10.00 V	All set-ups	TRUE	-2	Int16
6-22	Terminal 54 Low Current	4.00 mA	All set-ups	TRUE	-5	Int16
6-23	Terminal 54 High Current	20.00 mA	All set-ups	TRUE	-5	Int16
6-24	Terminal 54 Low Ref./Feedb. Value	0.000 N/A	All set-ups	TRUE	-3	Int32
6-25	Terminal 54 High Ref./Feedb. Value	100.000 N/A	All set-ups	TRUE	-3	Int32
6-26	Terminal 54 Filter Time Constant	0.001 s	All set-ups	TRUE	-3	Uint16
6-27	Terminal 54 Live Zero	[1] Enabled	All set-ups	TRUE	-	Uint8
<b>6-3* Analog Input X30/11</b>						
6-30	Terminal X30/11 Low Voltage	0.07 V	All set-ups	TRUE	-2	Int16
6-31	Terminal X30/11 High Voltage	10.00 V	All set-ups	TRUE	-2	Int16
6-34	Term. X30/11 Low Ref./Feedb. Value	0.000 N/A	All set-ups	TRUE	-3	Int32
6-35	Term. X30/11 High Ref./Feedb. Value	100.000 N/A	All set-ups	TRUE	-3	Int32
6-36	Term. X30/11 Filter Time Constant	0.001 s	All set-ups	TRUE	-3	Uint16
6-37	Term. X30/11 Live Zero	[1] Enabled	All set-ups	TRUE	-	Uint8
<b>6-4* Analog Input X30/12</b>						
6-40	Terminal X30/12 Low Voltage	0.07 V	All set-ups	TRUE	-2	Int16
6-41	Terminal X30/12 High Voltage	10.00 V	All set-ups	TRUE	-2	Int16
6-44	Term. X30/12 Low Ref./Feedb. Value	0.000 N/A	All set-ups	TRUE	-3	Int32
6-45	Term. X30/12 High Ref./Feedb. Value	100.000 N/A	All set-ups	TRUE	-3	Int32
6-46	Term. X30/12 Filter Time Constant	0.001 s	All set-ups	TRUE	-3	Uint16
6-47	Term. X30/12 Live Zero	[1] Enabled	All set-ups	TRUE	-	Uint8
<b>6-5* Analog Output 42</b>						
6-50	Terminal 42 Output	[100] Output freq. 0-100	All set-ups	TRUE	-	Uint8
6-51	Terminal 42 Output Min Scale	0.00 %	All set-ups	TRUE	-2	Int16
6-52	Terminal 42 Output Max Scale	100.00 %	All set-ups	TRUE	-2	Int16
6-53	Terminal 42 Output Bus Control	0.00 %	All set-ups	TRUE	-2	N2
6-54	Terminal 42 Output Timeout Preset	0.00 %	1 set-up	TRUE	-2	Uint16
<b>6-6* Analog Output X30/8</b>						
6-60	Terminal X30/8 Output	[0] No operation	All set-ups	TRUE	-	Uint8
6-61	Terminal X30/8 Min. Scale	0.00 %	All set-ups	TRUE	-2	Int16
6-62	Terminal X30/8 Max. Scale	100.00 %	All set-ups	TRUE	-2	Int16
6-63	Terminal X30/8 Output Bus Control	0.00 %	All set-ups	TRUE	-2	N2
6-64	Terminal X30/8 Output Timeout Preset	0.00 %	1 set-up	TRUE	-2	Uint16

**8.3.9 Comm. and Options 8-\*\***

Par. No. #	Parameter description	Default value	4-set-up	Change during operation	Conversion index	Type
<b>8-0* General Settings</b>						
8-01	Control Site	null	All set-ups	TRUE	-	Uint8
8-02	Control Source	null	All set-ups	TRUE	-	Uint8
8-03	Control Timeout Time	SR	1 set-up	TRUE	-1	Uint32
8-04	Control Timeout Function	[0] Off	1 set-up	TRUE	-	Uint8
8-05	End-of-Timeout Function	[1] Resume set-up	1 set-up	TRUE	-	Uint8
8-06	Reset Control Timeout	[0] Do not reset	All set-ups	TRUE	-	Uint8
8-07	Diagnosis Trigger	[0] Disable	2 set-ups	TRUE	-	Uint8
<b>8-1* Control Settings</b>						
8-10	Control Profile	[0] FC profile	All set-ups	TRUE	-	Uint8
8-13	Configurable Status Word STW	[1] Profile Default	All set-ups	TRUE	-	Uint8
8-14	Configurable Control Word CTW	[1] Profile default	All set-ups	TRUE	-	Uint8
<b>8-3* FC Port Settings</b>						
8-30	Protocol	null	1 set-up	TRUE	-	Uint8
8-31	Address	SR	1 set-up	TRUE	0	Uint8
8-32	Baud Rate	null	1 set-up	TRUE	-	Uint8
8-33	Parity / Stop Bits	null	1 set-up	TRUE	-	Uint8
8-35	Minimum Response Delay	SR	1 set-up	TRUE	-3	Uint16
8-36	Max Response Delay	SR	1 set-up	TRUE	-3	Uint16
8-37	Maximum Inter-Char Delay	SR	1 set-up	TRUE	-5	Uint16
<b>8-4* FC MC protocol set</b>						
8-40	Telegram Selection	[1] Standard telegram 1	2 set-ups	TRUE	-	Uint8
<b>8-5* Digital / Bus</b>						
8-50	Coasting Select	[3] Logic OR	All set-ups	TRUE	-	Uint8
8-52	DC Brake Select	[3] Logic OR	All set-ups	TRUE	-	Uint8
8-53	Start Select	[3] Logic OR	All set-ups	TRUE	-	Uint8
8-54	Reversing Select	null	All set-ups	TRUE	-	Uint8
8-55	Set-up Select	[3] Logic OR	All set-ups	TRUE	-	Uint8
8-56	Preset Reference Select	[3] Logic OR	All set-ups	TRUE	-	Uint8
<b>8-7* BACnet</b>						
8-70	BACnet Device Instance	1 N/A	1 set-up	TRUE	0	Uint32
8-72	MS/TP Max Masters	127 N/A	1 set-up	TRUE	0	Uint8
8-73	MS/TP Max Info Frames	1 N/A	1 set-up	TRUE	0	Uint16
8-74	"I-Am" Service	[0] Send at power-up	1 set-up	TRUE	-	Uint8
8-75	Initialisation Password	SR	1 set-up	TRUE	0	VisStr[20]
<b>8-8* FC Port Diagnostics</b>						
8-80	Bus Message Count	0 N/A	All set-ups	TRUE	0	Uint32
8-81	Bus Error Count	0 N/A	All set-ups	TRUE	0	Uint32
8-82	Slave Message Rcvd	0 N/A	All set-ups	TRUE	0	Uint32
8-83	Slave Error Count	0 N/A	All set-ups	TRUE	0	Uint32
<b>8-9* Bus Jog / Feedback</b>						
8-90	Bus Jog 1 Speed	100 RPM	All set-ups	TRUE	67	Uint16
8-91	Bus Jog 2 Speed	200 RPM	All set-ups	TRUE	67	Uint16
8-94	Bus Feedback 1	0 N/A	1 set-up	TRUE	0	N2
8-95	Bus Feedback 2	0 N/A	1 set-up	TRUE	0	N2
8-96	Bus Feedback 3	0 N/A	1 set-up	TRUE	0	N2



### 8.3.10 Profibus 9-\*\*

Par. No. #	Parameter description	Default value	4-set-up	Change during operation	Conversion index	Type
<b>8-0* General Settings</b>						
8-01	Control Site	null	All set-ups	TRUE	-	Uint8
8-02	Control Source	null	All set-ups	TRUE	-	Uint8
8-03	Control Timeout Time	SR	1 set-up	TRUE	-1	Uint32
8-04	Control Timeout Function	[0] Off	1 set-up	TRUE	-	Uint8
8-05	End-of-Timeout Function	[1] Resume set-up	1 set-up	TRUE	-	Uint8
8-06	Reset Control Timeout	[0] Do not reset	All set-ups	TRUE	-	Uint8
8-07	Diagnosis Trigger	[0] Disable	2 set-ups	TRUE	-	Uint8
<b>8-1* Control Settings</b>						
8-10	Control Profile	[0] FC profile	All set-ups	TRUE	-	Uint8
8-13	Configurable Status Word STW	[1] Profile Default	All set-ups	TRUE	-	Uint8
8-14	Configurable Control Word CTW	[1] Profile default	All set-ups	TRUE	-	Uint8
<b>8-3* FC Port Settings</b>						
8-30	Protocol	null	1 set-up	TRUE	-	Uint8
8-31	Address	SR	1 set-up	TRUE	0	Uint8
8-32	Baud Rate	null	1 set-up	TRUE	-	Uint8
8-33	Parity / Stop Bits	null	1 set-up	TRUE	-	Uint8
8-35	Minimum Response Delay	SR	1 set-up	TRUE	-3	Uint16
8-36	Max Response Delay	SR	1 set-up	TRUE	-3	Uint16
8-37	Maximum Inter-Char Delay	SR	1 set-up	TRUE	-5	Uint16
<b>8-4* FC MC protocol set</b>						
8-40	Telegram Selection	[1] Standard telegram 1	2 set-ups	TRUE	-	Uint8
<b>8-5* Digital/Bus</b>						
8-50	Coasting Select	[3] Logic OR	All set-ups	TRUE	-	Uint8
8-52	DC Brake Select	[3] Logic OR	All set-ups	TRUE	-	Uint8
8-53	Start Select	[3] Logic OR	All set-ups	TRUE	-	Uint8
8-54	Reversing Select	null	All set-ups	TRUE	-	Uint8
8-55	Set-up Select	[3] Logic OR	All set-ups	TRUE	-	Uint8
8-56	Preset Reference Select	[3] Logic OR	All set-ups	TRUE	-	Uint8
<b>8-7* BACnet</b>						
8-70	BACnet Device Instance	1 N/A	1 set-up	TRUE	0	Uint32
8-72	MS/TP Max Masters	127 N/A	1 set-up	TRUE	0	Uint8
8-73	MS/TP Max Info Frames	1 N/A	1 set-up	TRUE	0	Uint16
8-74	"I-Am" Service	[0] Send at power-up	1 set-up	TRUE	-	Uint8
8-75	Initialisation Password	SR	1 set-up	TRUE	0	VisStr[20]
<b>8-8* FC Port Diagnostics</b>						
8-80	Bus Message Count	0 N/A	All set-ups	TRUE	0	Uint32
8-81	Bus Error Count	0 N/A	All set-ups	TRUE	0	Uint32
8-82	Slave Message Rcvd	0 N/A	All set-ups	TRUE	0	Uint32
8-83	Slave Error Count	0 N/A	All set-ups	TRUE	0	Uint32
<b>8-9* Bus Jog / Feedback</b>						
8-90	Bus Jog 1 Speed	100 RPM	All set-ups	TRUE	67	Uint16
8-91	Bus Jog 2 Speed	200 RPM	All set-ups	TRUE	67	Uint16
8-94	Bus Feedback 1	0 N/A	1 set-up	TRUE	0	N2
8-95	Bus Feedback 2	0 N/A	1 set-up	TRUE	0	N2
8-96	Bus Feedback 3	0 N/A	1 set-up	TRUE	0	N2

**8.3.11 CAN Fieldbus 10-.\*.\***

Par. No. #	Parameter description	Default value	4-set-up	Change during operation	Conversion index	Type
<b>10-0* Common Settings</b>						
10-00	CAN Protocol	null	2 set-ups	FALSE	-	Uint8
10-01	Baud Rate Select	null	2 set-ups	TRUE	-	Uint8
10-02	MAC ID	SR	2 set-ups	TRUE	0	Uint8
10-05	Readout Transmit Error Counter	0 N/A	All set-ups	TRUE	0	Uint8
10-06	Readout Receive Error Counter	0 N/A	All set-ups	TRUE	0	Uint8
10-07	Readout Bus Off Counter	0 N/A	All set-ups	TRUE	0	Uint8
<b>10-1* DeviceNet</b>						
10-10	Process Data Type Selection	null	All set-ups	TRUE	-	Uint8
10-11	Process Data Config Write	SR	2 set-ups	TRUE	-	Uint16
10-12	Process Data Config Read	SR	2 set-ups	TRUE	-	Uint16
10-13	Warning Parameter	0 N/A	All set-ups	TRUE	0	Uint16
10-14	Net Reference	[0] Off	2 set-ups	TRUE	-	Uint8
10-15	Net Control	[0] Off	2 set-ups	TRUE	-	Uint8
<b>10-2* COS Filters</b>						
10-20	COS Filter 1	0 N/A	All set-ups	FALSE	0	Uint16
10-21	COS Filter 2	0 N/A	All set-ups	FALSE	0	Uint16
10-22	COS Filter 3	0 N/A	All set-ups	FALSE	0	Uint16
10-23	COS Filter 4	0 N/A	All set-ups	FALSE	0	Uint16
<b>10-3* Parameter Access</b>						
10-30	Array Index	0 N/A	2 set-ups	TRUE	0	Uint8
10-31	Store Data Values	[0] Off	All set-ups	TRUE	-	Uint8
10-32	DeviceNet Revision	SR	All set-ups	TRUE	0	Uint16
10-33	Store Always	[0] Off	1 set-up	TRUE	-	Uint8
10-34	DeviceNet Product Code	130 N/A	1 set-up	TRUE	0	Uint16
10-39	DeviceNet F Parameters	0 N/A	All set-ups	TRUE	0	Uint32

### 8.3.12 Smart Logic 13-\*\*

Par. No. #	Parameter description	Default value	4-set-up	Change during operation	Conversion index	Type
<b>13-0* SLC Settings</b>						
13-00	SL Controller Mode	null	2 set-ups	TRUE	-	Uint8
13-01	Start Event	null	2 set-ups	TRUE	-	Uint8
13-02	Stop Event	null	2 set-ups	TRUE	-	Uint8
13-03	Reset SLC	[0] Do not reset SLC	All set-ups	TRUE	-	Uint8
<b>13-1* Comparators</b>						
13-10	Comparator Operand	null	2 set-ups	TRUE	-	Uint8
13-11	Comparator Operator	null	2 set-ups	TRUE	-	Uint8
13-12	Comparator Value	SR	2 set-ups	TRUE	-3	Int32
<b>13-2* Timers</b>						
13-20	SL Controller Timer	SR	1 set-up	TRUE	-3	TimD
<b>13-4* Logic Rules</b>						
13-40	Logic Rule Boolean 1	null	2 set-ups	TRUE	-	Uint8
13-41	Logic Rule Operator 1	null	2 set-ups	TRUE	-	Uint8
13-42	Logic Rule Boolean 2	null	2 set-ups	TRUE	-	Uint8
13-43	Logic Rule Operator 2	null	2 set-ups	TRUE	-	Uint8
13-44	Logic Rule Boolean 3	null	2 set-ups	TRUE	-	Uint8
<b>13-5* States</b>						
13-51	SL Controller Event	null	2 set-ups	TRUE	-	Uint8
13-52	SL Controller Action	null	2 set-ups	TRUE	-	Uint8

## 8.3.13 Special Functions 14-\*\*

Par. No. #	Parameter description	Default value	4-set-up	Change during operation	Conversion index	Type
<b>14-0* Inverter Switching</b>						
14-00	Switching Pattern	null	All set-ups	TRUE	-	Uint8
14-01	Switching Frequency	null	All set-ups	TRUE	-	Uint8
14-03	Overmodulation	[1] On	All set-ups	FALSE	-	Uint8
14-04	PWM Random	[0] Off	All set-ups	TRUE	-	Uint8
<b>14-1* Mains On/Off</b>						
14-10	Mains Failure	[0] No function	All set-ups	FALSE	-	Uint8
14-11	Mains Voltage at Mains Fault	SR	All set-ups	TRUE	0	Uint16
14-12	Function at Mains Imbalance	[3] Derate	All set-ups	TRUE	-	Uint8
<b>14-2* Reset Functions</b>						
14-20	Reset Mode	[10] Automatic reset x 10	All set-ups	TRUE	-	Uint8
14-21	Automatic Restart Time	10 s	All set-ups	TRUE	0	Uint16
14-22	Operation Mode	[0] Normal operation	All set-ups	TRUE	-	Uint8
14-23	Typecode Setting	null	2 set-ups	FALSE	-	Uint8
14-25	Trip Delay at Torque Limit	60 s	All set-ups	TRUE	0	Uint8
14-26	Trip Delay at Inverter Fault	SR	All set-ups	TRUE	0	Uint8
14-28	Production Settings	[0] No action	All set-ups	TRUE	-	Uint8
14-29	Service Code	0 N/A	All set-ups	TRUE	0	Int32
<b>14-3* Current Limit Ctrl.</b>						
14-30	Current Lim Ctrl, Proportional Gain	100 %	All set-ups	FALSE	0	Uint16
14-31	Current Lim Ctrl, Integration Time	0.020 s	All set-ups	FALSE	-3	Uint16
14-32	Current Lim Ctrl, Filter Time	27.0 ms	All set-ups	FALSE	-4	Uint16
<b>14-4* Energy Optimising</b>						
14-40	VT Level	66 %	All set-ups	FALSE	0	Uint8
14-41	AEO Minimum Magnetisation	SR	All set-ups	TRUE	0	Uint8
14-42	Minimum AEO Frequency	10 Hz	All set-ups	TRUE	0	Uint8
14-43	Motor Cosphi	SR	All set-ups	TRUE	-2	Uint16
<b>14-5* Environment</b>						
14-50	RFI Filter	[1] On	1 set-up	FALSE	-	Uint8
14-52	Fan Control	[0] Auto	All set-ups	TRUE	-	Uint8
14-53	Fan Monitor	[1] Warning	All set-ups	TRUE	-	Uint8
14-55	Output Filter	[0] No Filter	1 set-up	FALSE	-	Uint8
14-59	Actual Number of Inverter Units	SR	1 set-up	FALSE	0	Uint8
<b>14-6* Auto Derate</b>						
14-60	Function at Over Temperature	[1] Derate	All set-ups	TRUE	-	Uint8
14-61	Function at Inverter Overload	[1] Derate	All set-ups	TRUE	-	Uint8
14-62	Inv. Overload Derate Current	95 %	All set-ups	TRUE	0	Uint16
<b>14-8* Options</b>						
14-80	Option Supplied by External 24VDC	[0] No	2 set-ups	FALSE	-	Uint8

### 8.3.14 FC Information 15-\*\*

Par. No. #	Parameter description	Default value	4-set-up	Change during operation	Conversion index	Type
<b>15-0* Operating Data</b>						
15-00	Operating Hours	0 h	All set-ups	FALSE	74	Uint32
15-01	Running Hours	0 h	All set-ups	FALSE	74	Uint32
15-02	kWh Counter	0 kWh	All set-ups	FALSE	75	Uint32
15-03	Power Up's	0 N/A	All set-ups	FALSE	0	Uint32
15-04	Over Temp's	0 N/A	All set-ups	FALSE	0	Uint16
15-05	Over Volt's	0 N/A	All set-ups	FALSE	0	Uint16
15-06	Reset kWh Counter	[0] Do not reset	All set-ups	TRUE	-	Uint8
15-07	Reset Running Hours Counter	[0] Do not reset	All set-ups	TRUE	-	Uint8
15-08	Number of Starts	0 N/A	All set-ups	FALSE	0	Uint32
<b>15-1* Data Log Settings</b>						
15-10	Logging Source	0	2 set-ups	TRUE	-	Uint16
15-11	Logging Interval	SR	2 set-ups	TRUE	-3	TimD
15-12	Trigger Event	[0] False	1 set-up	TRUE	-	Uint8
15-13	Logging Mode	[0] Log always	2 set-ups	TRUE	-	Uint8
15-14	Samples Before Trigger	50 N/A	2 set-ups	TRUE	0	Uint8
<b>15-2* Historic Log</b>						
15-20	Historic Log: Event	0 N/A	All set-ups	FALSE	0	Uint8
15-21	Historic Log: Value	0 N/A	All set-ups	FALSE	0	Uint32
15-22	Historic Log: Time	0 ms	All set-ups	FALSE	-3	Uint32
15-23	Historic Log: Date and Time	SR	All set-ups	FALSE	0	TimeOfDay
<b>15-3* Alarm Log</b>						
15-30	Alarm Log: Error Code	0 N/A	All set-ups	FALSE	0	Uint16
15-31	Alarm Log: Value	0 N/A	All set-ups	FALSE	0	Uint16
15-32	Alarm Log: Time	0 s	All set-ups	FALSE	0	Uint32
15-33	Alarm Log: Date and Time	SR	All set-ups	FALSE	0	TimeOfDay
15-34	Alarm Log: Setpoint	0.000 ProcessCtrlUnit	All set-ups	FALSE	-3	Int32
15-35	Alarm Log: Feedback	0.000 ProcessCtrlUnit	All set-ups	FALSE	-3	Int32
15-36	Alarm Log: Current Demand	0 %	All set-ups	FALSE	0	Uint8
15-37	Alarm Log: Process Ctrl Unit	[0]	All set-ups	FALSE	-	Uint8
<b>15-4* Drive Identification</b>						
15-40	FC Type	0 N/A	All set-ups	FALSE	0	VisStr[6]
15-41	Power Section	0 N/A	All set-ups	FALSE	0	VisStr[20]
15-42	Voltage	0 N/A	All set-ups	FALSE	0	VisStr[20]
15-43	Software Version	0 N/A	All set-ups	FALSE	0	VisStr[5]
15-44	Ordered Typecode String	0 N/A	All set-ups	FALSE	0	VisStr[40]
15-45	Actual Typecode String	0 N/A	All set-ups	FALSE	0	VisStr[40]
15-46	Frequency Converter Ordering No	0 N/A	All set-ups	FALSE	0	VisStr[8]
15-47	Power Card Ordering No	0 N/A	All set-ups	FALSE	0	VisStr[8]
15-48	LCP Id No	0 N/A	All set-ups	FALSE	0	VisStr[20]
15-49	SW ID Control Card	0 N/A	All set-ups	FALSE	0	VisStr[20]
15-50	SW ID Power Card	0 N/A	All set-ups	FALSE	0	VisStr[20]
15-51	Frequency Converter Serial Number	0 N/A	All set-ups	FALSE	0	VisStr[10]
15-53	Power Card Serial Number	0 N/A	All set-ups	FALSE	0	VisStr[19]

Par. No. #	Parameter description	Default value	4-set-up	Change during operation	Conversion index	Type
<b>15-6* Option Ident</b>						
15-60	Option Mounted	0 N/A	All set-ups	FALSE	0	VisStr[30]
15-61	Option SW Version	0 N/A	All set-ups	FALSE	0	VisStr[20]
15-62	Option Ordering No	0 N/A	All set-ups	FALSE	0	VisStr[8]
15-63	Option Serial No	0 N/A	All set-ups	FALSE	0	VisStr[18]
15-70	Option in Slot A	0 N/A	All set-ups	FALSE	0	VisStr[30]
15-71	Slot A Option SW Version	0 N/A	All set-ups	FALSE	0	VisStr[20]
15-72	Option in Slot B	0 N/A	All set-ups	FALSE	0	VisStr[30]
15-73	Slot B Option SW Version	0 N/A	All set-ups	FALSE	0	VisStr[20]
15-74	Option in Slot C0	0 N/A	All set-ups	FALSE	0	VisStr[30]
15-75	Slot C0 Option SW Version	0 N/A	All set-ups	FALSE	0	VisStr[20]
15-76	Option in Slot C1	0 N/A	All set-ups	FALSE	0	VisStr[30]
15-77	Slot C1 Option SW Version	0 N/A	All set-ups	FALSE	0	VisStr[20]
<b>15-9* Parameter Info</b>						
15-92	Defined Parameters	0 N/A	All set-ups	FALSE	0	Uint16
15-93	Modified Parameters	0 N/A	All set-ups	FALSE	0	Uint16
15-98	Drive Identification	0 N/A	All set-ups	FALSE	0	VisStr[40]
15-99	Parameter Metadata	0 N/A	All set-ups	FALSE	0	Uint16

### 8.3.15 Data Readouts 16-\*\*-\*\*

Par. No. #	Parameter description	Default value	4-set-up	Change during operation	Conversion index	Type
<b>16-0* General Status</b>						
16-00	Control Word	0 N/A	All set-ups	TRUE	0	V2
16-01	Reference [Unit]	0.000 ReferenceFeedbackUnit	All set-ups	TRUE	-3	Int32
16-02	Reference [%]	0.0 %	All set-ups	TRUE	-1	Int16
16-03	Status Word	0 N/A	All set-ups	TRUE	0	V2
16-05	Main Actual Value [%]	0.00 %	All set-ups	TRUE	-2	N2
16-09	Custom Readout	0.00 CustomReadoutUnit	All set-ups	TRUE	-2	Int32
<b>16-1* Motor Status</b>						
16-10	Power [kW]	0.00 kW	All set-ups	TRUE	1	Int32
16-11	Power [hp]	0.00 hp	All set-ups	TRUE	-2	Int32
16-12	Motor Voltage	0.0 V	All set-ups	TRUE	-1	Uint16
16-13	Frequency	0.0 Hz	All set-ups	TRUE	-1	Uint16
16-14	Motor Current	0.00 A	All set-ups	TRUE	-2	Int32
16-15	Frequency [%]	0.00 %	All set-ups	TRUE	-2	N2
16-16	Torque [Nm]	0.0 Nm	All set-ups	TRUE	-1	Int32
16-17	Speed [RPM]	0 RPM	All set-ups	TRUE	67	Int32
16-18	Motor Thermal	0 %	All set-ups	TRUE	0	Uint8
16-22	Torque [%]	0 %	All set-ups	TRUE	0	Int16
<b>16-3* Drive Status</b>						
16-30	DC Link Voltage	0 V	All set-ups	TRUE	0	Uint16
16-32	Brake Energy /s	0.000 kW	All set-ups	TRUE	0	Int32
16-33	Brake Energy /2 min	0.000 kW	All set-ups	TRUE	0	Int32
16-34	Heatsink Temp.	0 °C	All set-ups	TRUE	100	Uint8
16-35	Inverter Thermal	0 %	All set-ups	TRUE	0	Uint8
16-36	Inv. Nom. Current	SR	All set-ups	TRUE	-2	Uint32
16-37	Inv. Max. Current	SR	All set-ups	TRUE	-2	Uint32
16-38	SL Controller State	0 N/A	All set-ups	TRUE	0	Uint8
16-39	Control Card Temp.	0 °C	All set-ups	TRUE	100	Uint8
16-40	Logging Buffer Full	[0] No	All set-ups	TRUE	-	Uint8
<b>16-5* Ref. &amp; Feedb.</b>						
16-50	External Reference	0.0 N/A	All set-ups	TRUE	-1	Int16
16-52	Feedback [Unit]	0.000 ProcessCtrlUnit	All set-ups	TRUE	-3	Int32
16-53	Digi Pot Reference	0.00 N/A	All set-ups	TRUE	-2	Int16
16-54	Feedback 1 [Unit]	0.000 ProcessCtrlUnit	All set-ups	TRUE	-3	Int32
16-55	Feedback 2 [Unit]	0.000 ProcessCtrlUnit	All set-ups	TRUE	-3	Int32
16-56	Feedback 3 [Unit]	0.000 ProcessCtrlUnit	All set-ups	TRUE	-3	Int32
16-58	PID Output [%]	0.0 %	All set-ups	TRUE	-1	Int16
16-59	Adjusted Setpoint	0.000 ProcessCtrlUnit	All set-ups	TRUE	-3	Int32

Par. No. #	Parameter description	Default value	4-set-up	Change during operation	Conversion index	Type
<b>16-6* Inputs &amp; Outputs</b>						
16-60	Digital Input	0 N/A	All set-ups	TRUE	0	Uint16
16-61	Terminal 53 Switch Setting	[0] Current	All set-ups	TRUE	-	Uint8
16-62	Analog Input 53	0.000 N/A	All set-ups	TRUE	-3	Int32
16-63	Terminal 54 Switch Setting	[0] Current	All set-ups	TRUE	-	Uint8
16-64	Analog Input 54	0.000 N/A	All set-ups	TRUE	-3	Int32
16-65	Analog Output 42 [mA]	0.000 N/A	All set-ups	TRUE	-3	Int16
16-66	Digital Output [bin]	0 N/A	All set-ups	TRUE	0	Int16
16-67	Pulse Input #29 [Hz]	0 N/A	All set-ups	TRUE	0	Int32
16-68	Pulse Input #33 [Hz]	0 N/A	All set-ups	TRUE	0	Int32
16-69	Pulse Output #27 [Hz]	0 N/A	All set-ups	TRUE	0	Int32
16-70	Pulse Output #29 [Hz]	0 N/A	All set-ups	TRUE	0	Int32
16-71	Relay Output [bin]	0 N/A	All set-ups	TRUE	0	Uint16
16-72	Counter A	0 N/A	All set-ups	TRUE	0	Int32
16-73	Counter B	0 N/A	All set-ups	TRUE	0	Int32
16-75	Analog In X30/11	0.000 N/A	All set-ups	TRUE	-3	Int32
16-76	Analog In X30/12	0.000 N/A	All set-ups	TRUE	-3	Int32
16-77	Analog Out X30/8 [mA]	0.000 N/A	All set-ups	TRUE	-3	Int16
<b>16-8* Fieldbus &amp; FC Port</b>						
16-80	Fieldbus CTW 1	0 N/A	All set-ups	TRUE	0	V2
16-82	Fieldbus REF 1	0 N/A	All set-ups	TRUE	0	N2
16-84	Comm. Option STW	0 N/A	All set-ups	TRUE	0	V2
16-85	FC Port CTW 1	0 N/A	All set-ups	TRUE	0	V2
16-86	FC Port REF 1	0 N/A	All set-ups	TRUE	0	N2
<b>16-9* Diagnosis Readouts</b>						
16-90	Alarm Word	0 N/A	All set-ups	TRUE	0	Uint32
16-91	Alarm Word 2	0 N/A	All set-ups	TRUE	0	Uint32
16-92	Warning Word	0 N/A	All set-ups	TRUE	0	Uint32
16-93	Warning Word 2	0 N/A	All set-ups	TRUE	0	Uint32
16-94	Ext. Status Word	0 N/A	All set-ups	TRUE	0	Uint32
16-95	Ext. Status Word 2	0 N/A	All set-ups	TRUE	0	Uint32
16-96	Maintenance Word	0 N/A	All set-ups	TRUE	0	Uint32



### 8.3.16 Data Readouts 2 18-\*\*

Par. No. #	Parameter description	Default value	4-set-up	Change during operation	Conversion index	Type
<b>18-0* Maintenance Log</b>						
18-00	Maintenance Log: Item	0 N/A	All set-ups	FALSE	0	Uint8
18-01	Maintenance Log: Action	0 N/A	All set-ups	FALSE	0	Uint8
18-02	Maintenance Log: Time	0 s	All set-ups	FALSE	0	Uint32
18-03	Maintenance Log: Date and Time	SR	All set-ups	FALSE	0	TimeOfDay
<b>18-3* Inputs &amp; Outputs</b>						
18-30	Analog Input X42/1	0.000 N/A	All set-ups	FALSE	-3	Int32
18-31	Analog Input X42/3	0.000 N/A	All set-ups	FALSE	-3	Int32
18-32	Analog Input X42/5	0.000 N/A	All set-ups	FALSE	-3	Int32
18-33	Analog Out X42/7 [V]	0.000 N/A	All set-ups	FALSE	-3	Int16
18-34	Analog Out X42/9 [V]	0.000 N/A	All set-ups	FALSE	-3	Int16
18-35	Analog Out X42/11 [V]	0.000 N/A	All set-ups	FALSE	-3	Int16

**8.3.17 FC Closed Loop 20-\*\*-\***

Par. No. #	Parameter description	Default value	4-set-up	Change during operation	Conversion index	Type
<b>20-0* Feedback</b>						
20-00	Feedback 1 Source	[2] Analog input: 54	All set-ups	TRUE	-	Uint8
20-01	Feedback 1 Conversion	[0] Linear	All set-ups	FALSE	-	Uint8
20-02	Feedback 1 Source Unit	null	All set-ups	TRUE	-	Uint8
20-03	Feedback 2 Source	[0] No function	All set-ups	TRUE	-	Uint8
20-04	Feedback 2 Conversion	[0] Linear	All set-ups	FALSE	-	Uint8
20-05	Feedback 2 Source Unit	null	All set-ups	TRUE	-	Uint8
20-06	Feedback 3 Source	[0] No function	All set-ups	TRUE	-	Uint8
20-07	Feedback 3 Conversion	[0] Linear	All set-ups	FALSE	-	Uint8
20-08	Feedback 3 Source Unit	null	All set-ups	TRUE	-	Uint8
20-12	Reference/Feedback Unit	null	All set-ups	TRUE	-	Uint8
<b>20-2* Feedback/Setpoint</b>						
20-20	Feedback Function	[4] Maximum	All set-ups	TRUE	-	Uint8
20-21	Setpoint 1	0.000 ProcessCtrlUnit	All set-ups	TRUE	-3	Int32
20-22	Setpoint 2	0.000 ProcessCtrlUnit	All set-ups	TRUE	-3	Int32
20-23	Setpoint 3	0.000 ProcessCtrlUnit	All set-ups	TRUE	-3	Int32
<b>20-7* PID Autotuning</b>						
20-70	Closed Loop Type	[0] Auto	2 set-ups	TRUE	-	Uint8
20-71	PID Performance	[0] Normal	2 set-ups	TRUE	-	Uint8
20-72	PID Output Change	0.10 N/A	2 set-ups	TRUE	-2	Uint16
20-73	Minimum Feedback Level	-999999.000 ProcessCtrlUnit	2 set-ups	TRUE	-3	Int32
20-74	Maximum Feedback Level	999999.000 ProcessCtrlUnit	2 set-ups	TRUE	-3	Int32
20-79	PID Autotuning	[0] Disabled	All set-ups	TRUE	-	Uint8
<b>20-8* PID Basic Settings</b>						
20-81	PID Normal/ Inverse Control	[0] Normal	All set-ups	TRUE	-	Uint8
20-82	PID Start Speed [RPM]	SR	All set-ups	TRUE	67	Uint16
20-83	PID Start Speed [Hz]	SR	All set-ups	TRUE	-1	Uint16
20-84	On Reference Bandwidth	5 %	All set-ups	TRUE	0	Uint8
<b>20-9* PID Controller</b>						
20-91	PID Anti Windup	[1] On	All set-ups	TRUE	-	Uint8
20-93	PID Proportional Gain	2.00 N/A	All set-ups	TRUE	-2	Uint16
20-94	PID Integral Time	8.00 s	All set-ups	TRUE	-2	Uint32
20-95	PID Differentiation Time	0.00 s	All set-ups	TRUE	-2	Uint16
20-96	PID Diff. Gain Limit	5.0 N/A	All set-ups	TRUE	-1	Uint16

### 8.3.18 Ext. Closed Loop 21-\*\*

Par. No. #	Parameter description	Default value	4-set-up	Change during operation	Conversion index	Type
<b>21-0* Ext. CL Autotuning</b>						
21-00	Closed Loop Type	[0] Auto	2 set-ups	TRUE	-	Uint8
21-01	PID Performance	[0] Normal	2 set-ups	TRUE	-	Uint8
21-02	PID Output Change	0.10 N/A	2 set-ups	TRUE	-2	Uint16
21-03	Minimum Feedback Level	-99999.000 N/A	2 set-ups	TRUE	-3	Int32
21-04	Maximum Feedback Level	99999.000 N/A	2 set-ups	TRUE	-3	Int32
21-09	PID Auto Tuning	[0] Disabled	All set-ups	TRUE	-	Uint8
<b>21-1* Ext. CL 1 Ref./Fb.</b>						
21-10	Ext. 1 Ref./Feedback Unit	[0]	All set-ups	TRUE	-	Uint8
21-11	Ext. 1 Minimum Reference	0.000 ExtPID1Unit	All set-ups	TRUE	-3	Int32
21-12	Ext. 1 Maximum Reference	100.000 ExtPID1Unit	All set-ups	TRUE	-3	Int32
21-13	Ext. 1 Reference Source	[0] No function	All set-ups	TRUE	-	Uint8
21-14	Ext. 1 Feedback Source	[0] No function	All set-ups	TRUE	-	Uint8
21-15	Ext. 1 Setpoint	0.000 ExtPID1Unit	All set-ups	TRUE	-3	Int32
21-17	Ext. 1 Reference [Unit]	0.000 ExtPID1Unit	All set-ups	TRUE	-3	Int32
21-18	Ext. 1 Feedback [Unit]	0.000 ExtPID1Unit	All set-ups	TRUE	-3	Int32
21-19	Ext. 1 Output [%]	0 %	All set-ups	TRUE	0	Int32
<b>21-2* Ext. CL 1 PID</b>						
21-20	Ext. 1 Normal/Inverse Control	[0] Normal	All set-ups	TRUE	-	Uint8
21-21	Ext. 1 Proportional Gain	0.50 N/A	All set-ups	TRUE	-2	Uint16
21-22	Ext. 1 Integral Time	20.00 s	All set-ups	TRUE	-2	Uint32
21-23	Ext. 1 Differentiation Time	0.00 s	All set-ups	TRUE	-2	Uint16
21-24	Ext. 1 Dif. Gain Limit	5.0 N/A	All set-ups	TRUE	-1	Uint16
<b>21-3* Ext. CL 2 Ref./Fb.</b>						
21-30	Ext. 2 Ref./Feedback Unit	[0]	All set-ups	TRUE	-	Uint8
21-31	Ext. 2 Minimum Reference	0.000 ExtPID2Unit	All set-ups	TRUE	-3	Int32
21-32	Ext. 2 Maximum Reference	100.000 ExtPID2Unit	All set-ups	TRUE	-3	Int32
21-33	Ext. 2 Reference Source	[0] No function	All set-ups	TRUE	-	Uint8
21-34	Ext. 2 Feedback Source	[0] No function	All set-ups	TRUE	-	Uint8
21-35	Ext. 2 Setpoint	0.000 ExtPID2Unit	All set-ups	TRUE	-3	Int32
21-37	Ext. 2 Reference [Unit]	0.000 ExtPID2Unit	All set-ups	TRUE	-3	Int32
21-38	Ext. 2 Feedback [Unit]	0.000 ExtPID2Unit	All set-ups	TRUE	-3	Int32
21-39	Ext. 2 Output [%]	0 %	All set-ups	TRUE	0	Int32
<b>21-4* Ext. CL 2 PID</b>						
21-40	Ext. 2 Normal/Inverse Control	[0] Normal	All set-ups	TRUE	-	Uint8
21-41	Ext. 2 Proportional Gain	0.50 N/A	All set-ups	TRUE	-2	Uint16
21-42	Ext. 2 Integral Time	20.00 s	All set-ups	TRUE	-2	Uint32
21-43	Ext. 2 Differentiation Time	0.00 s	All set-ups	TRUE	-2	Uint16
21-44	Ext. 2 Dif. Gain Limit	5.0 N/A	All set-ups	TRUE	-1	Uint16

Par. No. #	Parameter description	Default value	4-set-up	Change during operation	Conversion index	Type
<b>21-5*</b>	<b>Ext. CL 3 Ref./Fb.</b>					
21-50	Ext. 3 Ref./Feedback Unit	[0]	All set-ups	TRUE	-	Uint8
21-51	Ext. 3 Minimum Reference	0.000 ExtPID3Unit	All set-ups	TRUE	-3	Int32
21-52	Ext. 3 Maximum Reference	100.000 ExtPID3Unit	All set-ups	TRUE	-3	Int32
21-53	Ext. 3 Reference Source	[0] No function	All set-ups	TRUE	-	Uint8
21-54	Ext. 3 Feedback Source	[0] No function	All set-ups	TRUE	-	Uint8
21-55	Ext. 3 Setpoint	0.000 ExtPID3Unit	All set-ups	TRUE	-3	Int32
21-57	Ext. 3 Reference [Unit]	0.000 ExtPID3Unit	All set-ups	TRUE	-3	Int32
21-58	Ext. 3 Feedback [Unit]	0.000 ExtPID3Unit	All set-ups	TRUE	-3	Int32
21-59	Ext. 3 Output [%]	0 %	All set-ups	TRUE	0	Int32
<b>21-6*</b>	<b>Ext. CL 3 PID</b>					
21-60	Ext. 3 Normal/Inverse Control	[0] Normal	All set-ups	TRUE	-	Uint8
21-61	Ext. 3 Proportional Gain	0.50 N/A	All set-ups	TRUE	-2	Uint16
21-62	Ext. 3 Integral Time	20.00 s	All set-ups	TRUE	-2	Uint32
21-63	Ext. 3 Differentiation Time	0.00 s	All set-ups	TRUE	-2	Uint16
21-64	Ext. 3 Dif. Gain Limit	5.0 N/A	All set-ups	TRUE	-1	Uint16

### 8.3.19 Application Functions 22-\*\*

Par. No. #	Parameter description	Default value	4-set-up	Change during operation	Conversion index	Type
<b>22-0* Miscellaneous</b>						
22-00	External Interlock Delay	0 s	All set-ups	TRUE	0	Uint16
<b>22-2* No-Flow Detection</b>						
22-20	Low Power Auto Set-up	[0] Off	All set-ups	FALSE	-	Uint8
22-21	Low Power Detection	[0] Disabled	All set-ups	TRUE	-	Uint8
22-22	Low Speed Detection	[0] Disabled	All set-ups	TRUE	-	Uint8
22-23	No-Flow Function	[0] Off	All set-ups	TRUE	-	Uint8
22-24	No-Flow Delay	10 s	All set-ups	TRUE	0	Uint16
22-26	Dry Pump Function	[0] Off	All set-ups	TRUE	-	Uint8
22-27	Dry Pump Delay	10 s	All set-ups	TRUE	0	Uint16
22-28	No-Flow Low Speed [RPM]	SR	All set-ups	TRUE	67	Uint16
22-29	No-Flow Low Speed [Hz]	SR	All set-ups	TRUE	-1	Uint16
<b>22-3* No-Flow Power Tuning</b>						
22-30	No-Flow Power	0.00 kW	All set-ups	TRUE	1	Uint32
22-31	Power Correction Factor	100 %	All set-ups	TRUE	0	Uint16
22-32	Low Speed [RPM]	SR	All set-ups	TRUE	67	Uint16
22-33	Low Speed [Hz]	SR	All set-ups	TRUE	-1	Uint16
22-34	Low Speed Power [kW]	SR	All set-ups	TRUE	1	Uint32
22-35	Low Speed Power [HP]	SR	All set-ups	TRUE	-2	Uint32
22-36	High Speed [RPM]	SR	All set-ups	TRUE	67	Uint16
22-37	High Speed [Hz]	SR	All set-ups	TRUE	-1	Uint16
22-38	High Speed Power [kW]	SR	All set-ups	TRUE	1	Uint32
22-39	High Speed Power [HP]	SR	All set-ups	TRUE	-2	Uint32
<b>22-4* Sleep Mode</b>						
22-40	Minimum Run Time	60 s	All set-ups	TRUE	0	Uint16
22-41	Minimum Sleep Time	30 s	All set-ups	TRUE	0	Uint16
22-42	Wake-up Speed [RPM]	SR	All set-ups	TRUE	67	Uint16
22-43	Wake-up Speed [Hz]	SR	All set-ups	TRUE	-1	Uint16
22-44	Wake-up Ref./FB Difference	10 %	All set-ups	TRUE	0	Int8
22-45	Setpoint Boost	0 %	All set-ups	TRUE	0	Int8
22-46	Maximum Boost Time	60 s	All set-ups	TRUE	0	Uint16
<b>22-5* End of Curve</b>						
22-50	End of Curve Function	[0] Off	All set-ups	TRUE	-	Uint8
22-51	End of Curve Delay	10 s	All set-ups	TRUE	0	Uint16
<b>22-6* Broken Belt Detection</b>						
22-60	Broken Belt Function	[0] Off	All set-ups	TRUE	-	Uint8
22-61	Broken Belt Torque	10 %	All set-ups	TRUE	0	Uint8
22-62	Broken Belt Delay	10 s	All set-ups	TRUE	0	Uint16
<b>22-7* Short Cycle Protection</b>						
22-75	Short Cycle Protection	[0] Disabled	All set-ups	TRUE	-	Uint8
22-76	Interval between Starts	start_to_start_min_on_time (P2277)	All set-ups	TRUE	0	Uint16
22-77	Minimum Run Time	0 s	All set-ups	TRUE	0	Uint16



Par. No. #	Parameter description	Default value	4-set-up	Change during operation	Conversion index	Type
<b>22-8* Flow Compensation</b>						
22-80	Flow Compensation	[0] Disabled	All set-ups	TRUE	-	Uint8
22-81	Square-linear Curve Approximation	100 %	All set-ups	TRUE	0	Uint8
22-82	Work Point Calculation	[0] Disabled	All set-ups	TRUE	-	Uint8
22-83	Speed at No-Flow [RPM]	SR	All set-ups	TRUE	67	Uint16
22-84	Speed at No-Flow [Hz]	SR	All set-ups	TRUE	-1	Uint16
22-85	Speed at Design Point [RPM]	SR	All set-ups	TRUE	67	Uint16
22-86	Speed at Design Point [Hz]	SR	All set-ups	TRUE	-1	Uint16
22-87	Pressure at No-Flow Speed	0.000 N/A	All set-ups	TRUE	-3	Int32
22-88	Pressure at Rated Speed	999999.999 N/A	All set-ups	TRUE	-3	Int32
22-89	Flow at Design Point	0.000 N/A	All set-ups	TRUE	-3	Int32
22-90	Flow at Rated Speed	0.000 N/A	All set-ups	TRUE	-3	Int32

### 8.3.20 Timed Actions 23-\*\*

Par. No. #	Parameter description	Default value	4-set-up	Change during operation	Conversion index	Type
<b>23-0* Timed Actions</b>						
23-00	ON Time	SR	2 set-ups	TRUE	0	TimeOfDay- WoDate UInt8
23-01	ON Action	[0] Disabled	2 set-ups	TRUE	-	TimeOfDay- WoDate UInt8
23-02	OFF Time	SR	2 set-ups	TRUE	0	TimeOfDay- WoDate UInt8
23-03	OFF Action	[0] Disabled	2 set-ups	TRUE	-	TimeOfDay- WoDate UInt8
23-04	Occurrence	[0] All days	2 set-ups	TRUE	-	TimeOfDay- WoDate UInt8
<b>23-1* Maintenance</b>						
23-10	Maintenance Item	[1] Motor bearings	1 set-up	TRUE	-	UInt8
23-11	Maintenance Action	[1] Lubricate	1 set-up	TRUE	-	UInt8
23-12	Maintenance Time Base	[0] Disabled	1 set-up	TRUE	-	UInt8
23-13	Maintenance Time Interval	1 h	1 set-up	TRUE	74	UInt32
23-14	Maintenance Date and Time	SR	1 set-up	TRUE	0	TimeOfDay
<b>23-1* Maintenance Reset</b>						
23-15	Reset Maintenance Word	[0] Do not reset	All set-ups	TRUE	-	UInt8
23-16	Maintenance Text	0 N/A	1 set-up	TRUE	0	VisStr[20]
<b>23-5* Energy Log</b>						
23-50	Energy Log Resolution	[5] Last 24 Hours	2 set-ups	TRUE	-	UInt8
23-51	Period Start	SR	2 set-ups	TRUE	0	TimeOfDay
23-53	Energy Log	0 N/A	All set-ups	TRUE	0	UInt32
23-54	Reset Energy Log	[0] Do not reset	All set-ups	TRUE	-	UInt8
<b>23-6* Trending</b>						
23-60	Trend Variable	[0] Power [kW]	2 set-ups	TRUE	-	UInt8
23-61	Continuous Bin Data	0 N/A	All set-ups	TRUE	0	UInt32
23-62	Timed Bin Data	0 N/A	All set-ups	TRUE	0	UInt32
23-63	Timed Period Start	SR	2 set-ups	TRUE	0	TimeOfDay
23-64	Timed Period Stop	SR	2 set-ups	TRUE	0	TimeOfDay
23-65	Minimum Bin Value	SR	2 set-ups	TRUE	0	UInt8
23-66	Reset Continuous Bin Data	[0] Do not reset	All set-ups	TRUE	-	UInt8
23-67	Reset Timed Bin Data	[0] Do not reset	All set-ups	TRUE	-	UInt8
<b>23-8* Payback Counter</b>						
23-80	Power Reference Factor	100 %	2 set-ups	TRUE	0	UInt8
23-81	Energy Cost	1.00 N/A	2 set-ups	TRUE	-2	UInt32
23-82	Investment	0 N/A	2 set-ups	TRUE	0	UInt32
23-83	Energy Savings	0 kWh	All set-ups	TRUE	75	Int32
23-84	Cost Savings	0 N/A	All set-ups	TRUE	0	Int32

**8.3.21 Cascade Controller 25-.\***

Par. No. #	Parameter description	Default value	4-set-up	Change during operation	Conversion index	Type
<b>25-0* System Settings</b>						
25-00	Cascade Controller	null	2 set-ups	FALSE	-	Uint8
25-02	Motor Start	[0] Direct on Line	2 set-ups	FALSE	-	Uint8
25-04	Pump Cycling	null	All set-ups	TRUE	-	Uint8
25-05	Fixed Lead Pump	null	2 set-ups	FALSE	-	Uint8
25-06	Number of Pumps	2 N/A	2 set-ups	FALSE	0	Uint8
<b>25-2* Bandwidth Settings</b>						
25-20	Staging Bandwidth	SR	All set-ups	TRUE	0	Uint8
25-21	Override Bandwidth	100 %	All set-ups	TRUE	0	Uint8
25-22	Fixed Speed Bandwidth	casco_staging_bandwidth (P2520)	All set-ups	TRUE	0	Uint8
25-23	SBW Staging Delay	15 s	All set-ups	TRUE	0	Uint16
25-24	SBW Destaging Delay	15 s	All set-ups	TRUE	0	Uint16
25-25	OBW Time	10 s	All set-ups	TRUE	0	Uint16
25-26	Destage At No-Flow	[0] Disabled	All set-ups	TRUE	-	Uint8
25-27	Stage Function	null	All set-ups	TRUE	-	Uint8
25-28	Stage Function Time	15 s	All set-ups	TRUE	0	Uint16
25-29	Destage Function	null	All set-ups	TRUE	-	Uint8
25-30	Destage Function Time	15 s	All set-ups	TRUE	0	Uint16
<b>25-4* Staging Settings</b>						
25-40	Ramp Down Delay	10.0 s	All set-ups	TRUE	-1	Uint16
25-41	Ramp Up Delay	2.0 s	All set-ups	TRUE	-1	Uint16
25-42	Staging Threshold	SR	All set-ups	TRUE	0	Uint8
25-43	Destaging Threshold	SR	All set-ups	TRUE	0	Uint8
25-44	Staging Speed [RPM]	0 RPM	All set-ups	TRUE	67	Uint16
25-45	Staging Speed [Hz]	0.0 Hz	All set-ups	TRUE	-1	Uint16
25-46	Destaging Speed [RPM]	0 RPM	All set-ups	TRUE	67	Uint16
25-47	Destaging Speed [Hz]	0.0 Hz	All set-ups	TRUE	-1	Uint16
<b>25-5* Alternation Settings</b>						
25-50	Lead Pump Alternation	null	All set-ups	TRUE	-	Uint8
25-51	Alternation Event	[0] External	All set-ups	TRUE	-	Uint8
25-52	Alternation Time Interval	24 h	All set-ups	TRUE	74	Uint16
25-53	Alternation Timer Value	0 N/A	All set-ups	TRUE	0	VisStr[7] TimeOfDay- WoDate
25-54	Alternation Predefined Time	SR	All set-ups	TRUE	0	Uint8
25-55	Alternate if Load < 50%	[1] Enabled	All set-ups	TRUE	-	Uint8
25-56	Staging Mode at Alternation	[0] Slow	All set-ups	TRUE	-	Uint8
25-58	Run Next Pump Delay	0.1 s	All set-ups	TRUE	-1	Uint16
25-59	Run on Mains Delay	0.5 s	All set-ups	TRUE	-1	Uint16



Par. No. #	Parameter description	Default value	4-set-up	Change during operation	Conversion index	Type
<b>25-8* Status</b>						
25-80	Cascade Status	0 N/A	All set-ups	TRUE	0	VisStr[25]
25-81	Pump Status	0 N/A	All set-ups	TRUE	0	VisStr[25]
25-82	Lead Pump	0 N/A	All set-ups	TRUE	0	Uint8
25-83	Relay Status	0 N/A	All set-ups	TRUE	0	VisStr[4]
25-84	Pump ON Time	0 h	All set-ups	TRUE	74	Uint32
25-85	Relay ON Time	0 h	All set-ups	TRUE	74	Uint32
25-86	Reset Relay Counters	[0] Do not reset	All set-ups	TRUE	-	Uint8
<b>25-9* Service</b>						
25-90	Pump Interlock	[0] Off	All set-ups	TRUE	-	Uint8
25-91	Manual Alternation	0 N/A	All set-ups	TRUE	0	Uint8

## 8.3.22 Analog I/O Option MCB 109 26-\*\*-\*\*

Par. No. #	Parameter description	Default value	4-set-up	Change during operation	Conversion index	Type
<b>26-0* Analog I/O Mode</b>						
26-00	Terminal X42/1 Mode	[1] Voltage	All set-ups	TRUE	-	Uint8
26-01	Terminal X42/3 Mode	[1] Voltage	All set-ups	TRUE	-	Uint8
26-02	Terminal X42/5 Mode	[1] Voltage	All set-ups	TRUE	-	Uint8
<b>26-1* Analog Input X42/1</b>						
26-10	Terminal X42/1 Low Voltage	0.07 V	All set-ups	TRUE	-2	Int16
26-11	Terminal X42/1 High Voltage	10.00 V	All set-ups	TRUE	-2	Int16
26-14	Term. X42/1 Low Ref./Feedb. Value	0.000 N/A	All set-ups	TRUE	-3	Int32
26-15	Term. X42/1 High Ref./Feedb. Value	100.000 N/A	All set-ups	TRUE	-3	Int32
26-16	Term. X42/1 Filter Time Constant	0.001 s	All set-ups	TRUE	-3	Uint16
26-17	Term. X42/1 Live Zero	[1] Enabled	All set-ups	TRUE	-	Uint8
<b>26-2* Analog Input X42/3</b>						
26-20	Terminal X42/3 Low Voltage	0.07 V	All set-ups	TRUE	-2	Int16
26-21	Terminal X42/3 High Voltage	10.00 V	All set-ups	TRUE	-2	Int16
26-24	Term. X42/3 Low Ref./Feedb. Value	0.000 N/A	All set-ups	TRUE	-3	Int32
26-25	Term. X42/3 High Ref./Feedb. Value	100.000 N/A	All set-ups	TRUE	-3	Int32
26-26	Term. X42/3 Filter Time Constant	0.001 s	All set-ups	TRUE	-3	Uint16
26-27	Term. X42/3 Live Zero	[1] Enabled	All set-ups	TRUE	-	Uint8
<b>26-3* Analog Input X42/5</b>						
26-30	Terminal X42/5 Low Voltage	0.07 V	All set-ups	TRUE	-2	Int16
26-31	Terminal X42/5 High Voltage	10.00 V	All set-ups	TRUE	-2	Int16
26-34	Term. X42/5 Low Ref./Feedb. Value	0.000 N/A	All set-ups	TRUE	-3	Int32
26-35	Term. X42/5 High Ref./Feedb. Value	100.000 N/A	All set-ups	TRUE	-3	Int32
26-36	Term. X42/5 Filter Time Constant	0.001 s	All set-ups	TRUE	-3	Uint16
26-37	Term. X42/5 Live Zero	[1] Enabled	All set-ups	TRUE	-	Uint8
<b>26-4* Analog Out X42/7</b>						
26-40	Terminal X42/7 Output	[0] No operation	All set-ups	TRUE	-	Uint8
26-41	Terminal X42/7 Min. Scale	0.00 %	All set-ups	TRUE	-2	Int16
26-42	Terminal X42/7 Max. Scale	100.00 %	All set-ups	TRUE	-2	Int16
26-43	Terminal X42/7 Bus Control	0.00 %	All set-ups	TRUE	-2	N2
26-44	Terminal X42/7 Timeout Preset	0.00 %	1 set-up	TRUE	-2	Uint16
<b>26-5* Analog Out X42/9</b>						
26-50	Terminal X42/9 Output	[0] No operation	All set-ups	TRUE	-	Uint8
26-51	Terminal X42/9 Min. Scale	0.00 %	All set-ups	TRUE	-2	Int16
26-52	Terminal X42/9 Max. Scale	100.00 %	All set-ups	TRUE	-2	Int16
26-53	Terminal X42/9 Bus Control	0.00 %	All set-ups	TRUE	-2	N2
26-54	Terminal X42/9 Timeout Preset	0.00 %	1 set-up	TRUE	-2	Uint16
<b>26-6* Analog Out X42/11</b>						
26-60	Terminal X42/11 Output	[0] No operation	All set-ups	TRUE	-	Uint8
26-61	Terminal X42/11 Min. Scale	0.00 %	All set-ups	TRUE	-2	Int16
26-62	Terminal X42/11 Max. Scale	100.00 %	All set-ups	TRUE	-2	Int16
26-63	Terminal X42/11 Bus Control	0.00 %	All set-ups	TRUE	-2	N2
26-64	Terminal X42/11 Timeout Preset	0.00 %	1 set-up	TRUE	-2	Uint16

### 8.3.23 Cascade CTL Option 27-\*\*-\*\*

Par. No. #	Parameter description	Default value	4-set-up	Change during operation	Conversion index	Type
<b>27-0* Control &amp; Status</b>						
27-01	Pump Status	[0] Ready	All set-ups	TRUE	-	Uint8
27-02	Manual Pump Control	[0] No Operation	2 set-ups	TRUE	-	Uint8
27-03	Current Runtime Hours	0 h	All set-ups	TRUE	74	Uint32
27-04	Pump Total Lifetime Hours	0 h	All set-ups	TRUE	74	Uint32
<b>27-1* Configuration</b>						
27-10	Cascade Controller	[0] Disabled	2 set-ups	FALSE	-	Uint8
27-11	Number Of Drives	1 N/A	2 set-ups	FALSE	0	Uint8
27-12	Number Of Pumps	SR	2 set-ups	FALSE	0	Uint8
27-14	Pump Capacity	100 %	2 set-ups	FALSE	0	Uint16
27-16	Runtime Balancing	[0] Balanced Priority 1	2 set-ups	TRUE	-	Uint8
27-17	Motor Starters	[0] Direct Online	2 set-ups	FALSE	-	Uint8
27-18	Spin Time for Unused Pumps	SR	All set-ups	TRUE	0	Uint16
27-19	Reset Current Runtime Hours	[0] Do not reset	All set-ups	TRUE	-	Uint8
<b>27-2* Bandwidth Settings</b>						
27-20	Normal Operating Range	SR	All set-ups	TRUE	0	Uint8
27-21	Override Limit	100 %	All set-ups	TRUE	0	Uint8
27-22	Fixed Speed Only Operating Range	SR	All set-ups	TRUE	0	Uint8
27-23	Staging Delay	15 s	All set-ups	TRUE	0	Uint16
27-24	Destaging Delay	15 s	All set-ups	TRUE	0	Uint16
27-25	Override Hold Time	10 s	All set-ups	TRUE	0	Uint16
27-27	Min Speed Destage Delay	SR	All set-ups	TRUE	0	Uint16
<b>27-3* Staging Speed</b>						
27-30	Auto Tune Staging Speeds	[1] Enabled	All set-ups	TRUE	-	Uint8
27-31	Stage On Speed [RPM]	SR	All set-ups	TRUE	67	Uint16
27-32	Stage On Speed [Hz]	SR	All set-ups	TRUE	-1	Uint16
27-33	Stage Off Speed [RPM]	SR	All set-ups	TRUE	67	Uint16
27-34	Stage Off Speed [Hz]	SR	All set-ups	TRUE	-1	Uint16
<b>27-4* Staging Settings</b>						
27-40	Auto Tune Staging Settings	[0] Disabled	All set-ups	TRUE	-	Uint8
27-41	Ramp Down Delay	10.0 s	All set-ups	TRUE	-1	Uint16
27-42	Ramp Up Delay	2.0 s	All set-ups	TRUE	-1	Uint16
27-43	Staging Threshold	SR	All set-ups	TRUE	0	Uint8
27-44	Destaging Threshold	SR	All set-ups	TRUE	0	Uint8
27-45	Staging Speed [RPM]	0 RPM	All set-ups	TRUE	67	Uint16
27-46	Staging Speed [Hz]	0.0 Hz	All set-ups	TRUE	-1	Uint16
27-47	Destaging Speed [RPM]	0 RPM	All set-ups	TRUE	67	Uint16
27-48	Destaging Speed [Hz]	0.0 Hz	All set-ups	TRUE	-1	Uint16
<b>27-5* Alternate Settings</b>						
27-50	Automatic Alternation	[0] Disabled	All set-ups	FALSE	-	Uint8
27-51	Alternation Event	null	All set-ups	TRUE	-	Uint8
27-52	Alternation Time Interval	0 min	All set-ups	TRUE	70	Uint16
27-53	Alternation Timer Value	0 min	All set-ups	TRUE	70	Uint16
27-54	Alternation At Time of Day	[0] Disabled	All set-ups	TRUE	-	Uint8
27-55	Alternation Predefined Time	SR	All set-ups	TRUE	0	WoDate
27-56	Alternate Capacity is <	0 %	All set-ups	TRUE	0	Uint8
27-58	Run Next Pump Delay	0.1 s	All set-ups	TRUE	-1	Uint16

Par. No. #	Parameter description	Default value	4-set-up	Change during operation	Conversion index	Type
<b>27-6* Digital Inputs</b>						
27-60	Terminal X66/1 Digital Input	[0] No operation	All set-ups	TRUE	-	Uint8
27-61	Terminal X66/3 Digital Input	[0] No operation	All set-ups	TRUE	-	Uint8
27-62	Terminal X66/5 Digital Input	[0] No operation	All set-ups	TRUE	-	Uint8
27-63	Terminal X66/7 Digital Input	[0] No operation	All set-ups	TRUE	-	Uint8
27-64	Terminal X66/9 Digital Input	[0] No operation	All set-ups	TRUE	-	Uint8
27-65	Terminal X66/11 Digital Input	[0] No operation	All set-ups	TRUE	-	Uint8
27-66	Terminal X66/13 Digital Input	[0] No operation	All set-ups	TRUE	-	Uint8
<b>27-7* Connections</b>						
27-70	Relay	[0] Standard Relay	2 set-ups	FALSE	-	Uint8
<b>27-9* Readouts</b>						
27-91	Cascade Reference	0.0 %	All set-ups	TRUE	-1	Int16
27-92	% Of Total Capacity	0 %	All set-ups	TRUE	0	Uint16
27-93	Cascade Option Status	[0] Disabled	All set-ups	TRUE	-	Uint8
27-94	Cascade System Status	0 N/A	All set-ups	TRUE	0	VisStr[25]

### 8.3.24 Water Application Functions 29-\*\*

Par. No. #	Parameter description	Default value	4-set-up	Change during operation	Conversion index	Type
<b>29-0* Pipe Fill</b>						
29-00	Pipe Fill Enable	[0] Disabled	2 set-ups	FALSE	-	Uint8
29-01	Pipe Fill Speed [RPM]	SR	All set-ups	TRUE	67	Uint16
29-02	Pipe Fill Speed [Hz]	SR	All set-ups	TRUE	-1	Uint16
29-03	Pipe Fill Time	0.00 s	All set-ups	TRUE	-2	Uint32
29-04	Pipe Fill Rate	0.001 ProcessCtrlUnit	All set-ups	TRUE	-3	Int32
29-05	Filled Setpoint	0.000 ProcessCtrlUnit	All set-ups	TRUE	-3	Int32

**8.3.25 Bypass Option 31-.\*.\***

Par. No. #	Parameter description	Default value	4-set-up	Change during operation	Conversion index	Type
31-00	Bypass Mode	[0] Drive	All set-ups	TRUE	-	Uint8
31-01	Bypass Start Time Delay	30 s	All set-ups	TRUE	0	Uint16
31-02	Bypass Trip Time Delay	0 s	All set-ups	TRUE	0	Uint16
31-03	Test Mode Activation	[0] Disabled	All set-ups	TRUE	-	Uint8
31-10	Bypass Status Word	0 N/A	All set-ups	FALSE	0	V2
31-11	Bypass Running Hours	0 h	All set-ups	FALSE	74	Uint32
31-19	Remote Bypass Activation	[0] Disabled	2 set-ups	TRUE	-	Uint8

## 9 Troubleshooting

### 9.1 Alarms and warnings

A warning or an alarm is signalled by the relevant LED on the front of the frequency converter and indicated by a code on the display.

A warning remains active until its cause is no longer present. Under certain circumstances operation of the motor may still be continued. Warning messages may be critical, but are not necessarily so.

In the event of an alarm, the frequency converter will have tripped. Alarms must be reset to restart operation once their cause has been rectified.

**This may be done in four ways:**

1. By using the [RESET] control button on the LCP control panel.
2. Via a digital input with the "Reset" function.
3. Via serial communication/optional fieldbus.
4. By resetting automatically using the [Auto Reset] function, which is a default setting for VLT AQUA Drive. see par. 14-20 *Reset Mode* in **VLT AQUA Drive Programming Guide**



**NB!**

After a manual reset using the [RESET] button on the LCP, the [AUTO ON] or [HAND ON] button must be pressed to restart the motor.

If an alarm cannot be reset, the reason may be that its cause has not been rectified, or the alarm is trip-locked (see also table on following page).

Alarms that are trip-locked offer additional protection, means that the mains supply must be switched off before the alarm can be reset. After being switched back on, the frequency converter is no longer blocked and may be reset as described above once the cause has been rectified.

Alarms that are not trip-locked can also be reset using the automatic reset function in par. 14-20 *Reset Mode* (Warning: automatic wake-up is possible!)

If a warning and alarm is marked against a code in the table on the following page, this means that either a warning occurs before an alarm, or it can be specified whether it is a warning or an alarm that is to be displayed for a given fault.

This is possible, for instance, in par. 1-90 *Motor Thermal Protection*. After an alarm or trip, the motor carries on coasting, and the alarm and warning flash on the frequency converter. Once the problem has been rectified, only the alarm continues flashing.

No.	Description	Warning	Alarm/Trip	Alarm/Trip Lock	Parameter Reference
1	10 Volts low	X			
2	Live zero error	(X)	(X)		6-01
3	No motor	(X)			1-80
4	Mains phase loss	(X)	(X)	(X)	14-12
5	DC link voltage high	X			
6	DC link voltage low	X			
7	DC over voltage	X	X		
8	DC under voltage	X	X		
9	Inverter overloaded	X	X		
10	Motor ETR over temperature	(X)	(X)		1-90
11	Motor thermistor over temperature	(X)	(X)		1-90
12	Torque limit	X	X		
13	Over Current	X	X	X	
14	Earth fault	X	X	X	
15	Hardware mismatch		X	X	
16	Short Circuit		X	X	
17	Control word timeout	(X)	(X)		8-04
23	Internal Fan Fault	X			
24	External Fan Fault	X			14-53
25	Brake resistor short-circuited	X			
26	Brake resistor power limit	(X)	(X)		2-13
27	Brake chopper short-circuited	X	X		
28	Brake check	(X)	(X)		2-15
29	Drive over temperature	X	X	X	
30	Motor phase U missing	(X)	(X)	(X)	4-58
31	Motor phase V missing	(X)	(X)	(X)	4-58
32	Motor phase W missing	(X)	(X)	(X)	4-58
33	Inrush fault		X	X	
34	Fieldbus communication fault	X	X		
35	Out of frequency range	X	X		
36	Mains failure	X	X		
37	Phase Imbalance	X	X		
38	Internal fault		X	X	
39	Heatsink sensor		X	X	
40	Overload of Digital Output Terminal 27	(X)			5-00, 5-01
41	Overload of Digital Output Terminal 29	(X)			5-00, 5-02
42	Overload of Digital Output On X30/6	(X)			5-32
42	Overload of Digital Output On X30/7	(X)			5-33
46	Pwr. card supply		X	X	
47	24 V supply low	X	X	X	
48	1.8 V supply low		X	X	
49	Speed limit	X			
50	AMA calibration failed		X		
51	AMA check $U_{nom}$ and $I_{nom}$		X		
52	AMA low $I_{nom}$		X		
53	AMA motor too big		X		
54	AMA motor too small		X		
55	AMA parameter out of range		X		
56	AMA interrupted by user		X		
57	AMA timeout		X		
58	AMA internal fault	X	X		
59	Current limit	X			
60	External Interlock	X			
62	Output Frequency at Maximum Limit	X			
64	Voltage Limit	X			
65	Control Board Over-temperature	X	X	X	
66	Heat sink Temperature Low	X			
67	Option Configuration has Changed		X		
68	Safe Stop Activated		X <sup>1)</sup>		
69	Pwr. Card Temp		X	X	
70	Illegal FC configuration			X	
71	PTC 1 Safe Stop	X	X <sup>1)</sup>		
72	Dangerous Failure			X <sup>1)</sup>	
73	Safe Stop Auto Restart				
79	Illegal PS config		X	X	
80	Drive Initialised to Default Value		X		
91	Analog input 54 wrong settings			X	
92	NoFlow	X	X		22-2*
93	Dry Pump	X	X		22-2*
94	End of Curve	X	X		22-5*
95	Broken Belt	X	X		22-6*
96	Start Delayed	X			22-7*
97	Stop Delayed	X			22-7*
98	Clock Fault	X			0-7*

Table 9.1: Alarm/Warning code list



No.	Description	Warning	Alarm/Trip	Alarm/Trip Lock	Parameter Reference
220	Overload Trip		X		
243	Brake IGBT	X	X		
244	Heatsink temp	X	X	X	
245	Heatsink sensor		X	X	
246	Pwr.card supply		X	X	
247	Pwr.card temp		X	X	
248	Illegal PS config		X	X	
250	New spare part			X	
251	New Type Code		X	X	

Table 9.3: Alarm/Warning code list

(X) Dependent on parameter

1) Can not be Auto reset via par. 14-20 *Reset Mode*

A trip is the action when an alarm has appeared. The trip will coast the motor and can be reset by pressing the reset button or make a reset by a digital input (Par. 5-1\* [1]). The origin event that caused an alarm cannot damage the frequency converter or cause dangerous conditions. A trip lock is an action when an alarm occurs, which may cause damage to frequency converter or connected parts. A Trip Lock situation can only be reset by a power cycling.

LED indication	
Warning	yellow
Alarm	flashing red
Trip locked	yellow and red

Alarm Word and Extended Status Word					
Bit	Hex	Dec	Alarm Word	Warning Word	Extended Status Word
0	00000001	1	Brake Check	Brake Check	Ramping
1	00000002	2	Pwr. Card Temp	Pwr. Card Temp	AMA Running
2	00000004	4	Earth Fault	Earth Fault	Start CW/CCW
3	00000008	8	Ctrl.Card Temp	Ctrl.Card Temp	Slow Down
4	00000010	16	Ctrl. Word TO	Ctrl. Word TO	Catch Up
5	00000020	32	Over Current	Over Current	Feedback High
6	00000040	64	Torque Limit	Torque Limit	Feedback Low
7	00000080	128	Motor Th Over	Motor Th Over	Output Current High
8	00000100	256	Motor ETR Over	Motor ETR Over	Output Current Low
9	00000200	512	Inverter Overld.	Inverter Overld.	Output Freq High
10	00000400	1024	DC under Volt	DC under Volt	Output Freq Low
11	00000800	2048	DC over Volt	DC over Volt	Brake Check OK
12	00001000	4096	Short Circuit	DC Voltage Low	Braking Max
13	00002000	8192	Inrush Fault	DC Voltage High	Braking
14	00004000	16384	Mains ph. Loss	Mains ph. Loss	Out of Speed Range
15	00008000	32768	AMA Not OK	No Motor	OVC Active
16	00010000	65536	Live Zero Error	Live Zero Error	
17	00020000	131072	Internal Fault	10V Low	
18	00040000	262144	Brake Overload	Brake Overload	
19	00080000	524288	U phase Loss	Brake Resistor	
20	00100000	1048576	V phase Loss	Brake IGBT	
21	00200000	2097152	W phase Loss	Speed Limit	
22	00400000	4194304	Fieldbus Fault	Fieldbus Fault	
23	00800000	8388608	24 V Supply Low	24V Supply Low	
24	01000000	16777216	Mains Failure	Mains Failure	
25	02000000	33554432	1.8V Supply Low	Current Limit	
26	04000000	67108864	Brake Resistor	Low Temp	
27	08000000	134217728	Brake IGBT	Voltage Limit	
28	10000000	268435456	Option Change	Unused	
29	20000000	536870912	Drive Initialised	Unused	
30	40000000	1073741824	Safe Stop	Unused	

Table 9.4: Description of Alarm Word, Warning Word and Extended Status Word

The alarm words, warning words and extended status words can be read out via serial bus or optional fieldbus for diagnosis. See also par. 16-90 *Alarm Word*, par. 16-92 *Warning Word* and par. 16-94 *Ext. Status Word*.

### 9.1.1 Fault messages

#### WARNING 1, 10 Volts low:

The 10 V voltage from terminal 50 on the control card is below 10 V. Remove some of the load from terminal 50, as the 10 V supply is overloaded. Max. 15 mA or minimum 590 Ω.

#### WARNING/ALARM 2, Live zero error:

The signal on terminal 53 or 54 is less than 50% of the value set in par. 6-10 *Terminal 53 Low Voltage*, par. 6-12 *Terminal 53 Low Current*, par. 6-20 *Terminal 54 Low Voltage*, or par. 6-22 *Terminal 54 Low Current* respectively.

#### WARNING/ALARM 3, No motor:

No motor has been connected to the output of the frequency converter.

#### WARNING/ALARM 4, Mains phase loss:

A phase is missing on the supply side, or the mains voltage imbalance is too high.

This message also appears in case of a fault in the input rectifier on the frequency converter.

Check the supply voltage and supply currents to the frequency converter.

#### WARNING 5, DC link voltage high:

The intermediate circuit voltage (DC) is higher than the over-voltage limit of the control system. The frequency converter is still active.

#### WARNING 6, DC link voltage low:

The intermediate circuit voltage (DC) is below the undervoltage limit of the control system. The frequency converter is still active.

#### WARNING/ALARM 7, DC over voltage:

If the intermediate circuit voltage exceeds the limit, the frequency converter trips after a time.

##### Possible corrections:

Select **Over Voltage Control** function in par. 2-17 *Over-voltage Control*

Connect a brake resistor

Extend the ramp time

Activate functions in par. 2-10 *Brake Function*

Increase par. 14-26 *Trip Delay at Inverter Fault*

Selecting OVC function will extend the ramp times.

Alarm/warning limits:			
Voltage Range	3 x 200-240 VAC [VDC]	3 x 380-500 VAC [VDC]	3 x 550-600 VAC [VDC]
Under voltage	185	373	532
Voltage warning low	205	410	585
Voltage warning high (w/o brake - w/ brake)	390/405	810/840	943/965
Over voltage	410	855	975

The voltages stated are the intermediate circuit voltage of the frequency converter with a tolerance of ± 5 %. The corresponding mains voltage is the intermediate circuit voltage (DC-link) divided by 1.35

#### WARNING/ALARM 8, DC under voltage:

If the intermediate circuit voltage (DC) drops below the "voltage warning low" limit (see table above), the frequency converter checks if 24 V backup supply is connected.

If no 24 V backup supply is connected, the frequency converter trips after a given time depending on the unit.

To check whether the supply voltage matches the frequency converter, see 3.1 *General Specifications*.

#### WARNING/ALARM 9, Inverter overloaded:

The frequency converter is about to cut out because of an overload (too high current for too long). The counter for electronic, thermal inverter protection gives a warning at 98% and trips at 100%, while giving an alarm. You cannot reset the frequency converter until the counter is below 90%.

The fault is that the frequency converter is overloaded by more than nominal current for too long.

#### WARNING/ALARM 10, Motor ETR over temperature:

According to the electronic thermal protection (ETR), the motor is too hot. You can choose if you want the frequency converter to give a warning or an alarm when the counter reaches 100% in par. 1-90 *Motor Thermal Protection*. The fault is that the motor is overloaded by more than nominal current for too long. Check that the motor par. 1-24 *Motor Current* is set correctly.

#### WARNING/ALARM 11, Motor thermistor over temp:

The thermistor or the thermistor connection is disconnected. You can choose if you want the frequency converter to give a warning or an alarm in par. 1-90 *Motor Thermal Protection*. Check that the thermistor is connected correctly between terminal 53 or 54 (analog voltage input) and terminal 50 (+ 10 Volts supply), or between terminal 18 or 19 (digital input PNP only) and terminal 50. If a KTY sensor is used, check for correct connection between terminal 54 and 55.

#### WARNING/ALARM 12, Torque limit:

The torque is higher than the value in par. 4-16 *Torque Limit Motor Mode* (in motor operation) or the torque is higher than the value in par. 4-17 *Torque Limit Generator Mode* (in regenerative operation).

#### WARNING/ALARM 13, Over Current:

The inverter peak current limit (approx. 200% of the rated current) is exceeded. The warning will last approx. 8-12 sec., then the frequency converter trips and issues an alarm. Turn off the frequency converter and check if the motor shaft can be turned and if the motor size matches the frequency converter.

#### ALARM 14, Earth fault:

There is a discharge from the output phases to earth, either in the cable between the frequency converter and the motor or in the motor itself. Turn off the frequency converter and remove the earth fault.

#### ALARM 15, In-complete hardware:

A fitted option is not handled by the present control board (hardware or software).

#### ALARM 16, Short-circuit:

There is short-circuiting in the motor or on the motor terminals. Turn off the frequency converter and remove the short-circuit.

#### WARNING/ALARM 17, Control word timeout:

There is no communication to the frequency converter.

The warning will only be active when par. 8-04 *Control Timeout Function* is NOT set to OFF.

If par. 8-04 *Control Timeout Function* is set to *Stop* and *Trip*, a warning appears and the frequency converter ramps down to zero speed, while giving an alarm.

par. 8-03 *Control Timeout Time* could possibly be increased.

**WARNING 23, Internal fans:**

External fans have failed due to defect hardware or fans not mounted.

**WARNING 24, External fan fault:**

The fan warning function is an extra protection function that checks if the fan is running / mounted. The fan warning can be disabled in par. 14-53 *Fan Monitor*, [0] Disabled.

**WARNING 25, Brake resistor short-circuited:**

The brake resistor is monitored during operation. If it short-circuits, the brake function is disconnected and the warning appears. The frequency converter still works, but without the brake function. Turn off the frequency converter and replace the brake resistor (see par. 2-15 *Brake Check*).


**ALARM/WARNING 26, Brake resistor power limit:**

The power transmitted to the brake resistor is calculated as a percentage, as a mean value over the last 120 s, on the basis of the resistance value of the brake resistor (par. 2-11 *Brake Resistor (ohm)*) and the intermediate circuit voltage. The warning is active when the dissipated braking power is higher than 90%. If *Trip* [2] has been selected in par. 2-13 *Brake Power Monitoring*, the frequency converter cuts out and issues this alarm, when the dissipated braking power is higher than 100%.

**WARNING/ALARM 27, Brake chopper fault:**

The brake transistor is monitored during operation and if it short-circuits, the brake function disconnects and the warning comes up. The frequency converter is still able to run, but since the brake transistor has short-circuited, substantial power is transmitted to the brake resistor, even if it is inactive.

Turn off the frequency converter and remove the brake resistor.



Warning: There is a risk of substantial power being transmitted to the brake resistor if the brake transistor is short-circuited.

**ALARM/WARNING 28, Brake check failed:**

Brake resistor fault: the brake resistor is not connected/working.

**WARNING/ALARM 29, Drive over temperature:**

If the enclosure is IP00 or IP20/Nema1 the cut-out temperature of the heat-sink is 90 °C. If IP54 is used, the cut-out temperature is 80 °C.

**The fault could be:**

- Ambient temperature too high
- Too long motor cable

**ALARM 30, Motor phase U missing:**

Motor phase U between the frequency converter and the motor is missing.

Turn off the frequency converter and check motor phase U.

**ALARM 31, Motor phase V missing:**

Motor phase V between the frequency converter and the motor is missing. Turn off the frequency converter and check motor phase V.

**ALARM 32, Motor phase W missing:**

Motor phase W between the frequency converter and the motor is missing.

Turn off the frequency converter and check motor phase W.

**ALARM 33, Inrush fault:**

Too many powerups have occurred within a short time period. See the chapter *General Specifications* for the allowed number of power-ups within one minute.

**WARNING/ALARM 34, Fieldbus communication fault:**

The fieldbus on the communication option card is not working.

**WARNING/ALARM 35, Option Fault:**

Option fault. Please contact your supplier.

**WARNING/ALARM 36, Mains failure:**

This warning/alarm is only active if the supply voltage to the frequency converter is lost and parameter 14-10 is NOT set to OFF. Possible correction: check the fuses to the frequency converter

**WARNING/ALARM 37, Phase Imbalance:**

There is a current imbalance between the power units.

**ALARM 38, Internal fault:**

Contact your local Danfoss supplier.

**ALARM 39, Heatsink Sensor:**

No feedback from the heatsink sensor.

**WARNING 40, Overload of Digital Output Terminal 27**

Check the load connected to terminal 27 or remove short-circuit connection. Check parameters 5-00 and 5-01.

**WARNING 41, Overload of Digital Output Terminal 29:**

Check the load connected to terminal 29 or remove short-circuit connection. Check parameters 5-00 and 5-02.

**WARNING 42, Overload of Digital Output On X30/6 :**

Check the load connected to X30/6 or remove short-circuit connection. Check parameter 5-32.

**WARNING 42, Overload of Digital Output On X30/7 :**

Check the load connected to X30/7 or remove short-circuit connection. Check parameter 5-33.

**ALARM 46, Pwr. card supply:**

The supply on the power card is out of range.

**WARNING 47, 24 V supply low:**

The external 24 V DC backup power supply may be overloaded, otherwise contact your Danfoss supplier.

**ALARM 48, 1.8 V supply low:**

Contact your Danfoss supplier.

**WARNING 49, Speed limit:**

The speed has been limited by range in par. 4-11 *Motor Speed Low Limit [RPM]* and par. 4-13 *Motor Speed High Limit [RPM]*.

**ALARM 50, AMA calibration failed:**

Contact your Danfoss supplier.

**ALARM 51, AMA check Unom and Inom:**

The setting of motor voltage, motor current, and motor power is presumably wrong. Check the settings.

**ALARM 52, AMA low Inom:**

The motor current is too low. Check the settings.

**ALARM 53, AMA motor too big:**

The motor is too big for the AMA to be carried out.

**ALARM 54, AMA motor too small:**

The motor is too small for the AMA to be carried out.

**ALARM 55, AMA par. out of range:**

The par. values found from the motor are outside acceptable range.

**ALARM 56, AMA interrupted by user:**

The AMA has been interrupted by the user.

**ALARM 57, AMA timeout:**

Try to start the AMA again a number of times, until the AMA is carried out. Please note that repeated runs may heat the motor to a level where the resistance  $R_s$  and  $R_r$  are increased. In most cases, however, this is not critical.

**WARNING/ALARM 58, AMA internal fault:**

Contact your Danfoss supplier.

**WARNING 59, Current limit:**

The current is higher than the value in par. 4-18 *Current Limit*.

**WARNING 60, External Interlock:**

External Interlock has been activated. To resume normal operation, apply 24 VDC to the terminal programmed for External Interlock and reset the frequency converter (via Bus, Digital I/O or by pressing [Reset]).

**WARNING 62, Output Frequency at Maximum Limit:**

The output frequency is limited by the value set in par. 4-19 *Max Output Frequency*

**WARNING 64, Voltage Limit:**

The load and speed combination demands a motor voltage higher than the actual DC link voltage.

**WARNING/ALARM/TRIP 65, Control Card Over Temperature:**

Control card over temperature: The cut-out temperature of the control card is 80° C.

**WARNING 66, Heatsink Temperature Low:**

The heat sink temperature is measured as 0° C. This could indicate that the temperature sensor is defective and thus the fan speed is increased to the maximum in case the power part or control card is very hot. If the temperature is below 15° C the warning will be present.

**ALARM 67, Option Configuration has Changed:**

One or more options has either been added or removed since the last power-down.

**ALARM 68, Safe Stop:**

Safe Stop has been activated. To resume normal operation, apply 24 VDC to terminal 37 then send a Reset signal (via Bus, Digital I/O or by pressing [Reset]).

**ALARM 69, Pwr. Card Temp:**

Power card over temperature.

**ALARM 70, Illegal Frequency Converter Configuration:**

Actual combination of control board and power board is illegal.

**ALARM 90, Feedback Mon.:****ALARM 91, Analogue Input 54 Wrong Settings:**

Switch S202 has to be set in position OFF (voltage input), when a KTY sensor is connected to the analogue input terminal 54.

**ALARM 92, NoFlow:**

A no load situation has been detected for the system. See parameter group 22-2\*.

**ALARM 93, Dry Pump:**

A no flow situation and high speed indicates that the pump has run dry. See parameter group 22-2\*

**ALARM 94, End of Curve:**

Feed back stays lower than the set point, which may indicate a leakage in the pipe system. See parameter group 22-5\*

**ALARM 95, Broken Belt:**

Torque is below the torque level set for no load indicating a broken belt. See parameter group 22-6\*

**ALARM 96, Start Delayed:**

Start of the motor has been delayed due to short cycle protection is active. See parameter group 22-7\*.

**ALARM 220, Overload Trip:**

Motor overload has tripped. Indicates excess motor load. Check motor and driven load. To reset press the "Off Reset" key. Then, to restart the system, press the "Auto On" or "Hand On" key.

**WARNING/ALARM 243, Brake IGBT:**

The brake transistor is short-circuited or the brake function is disconnected. Turn off the frequency converter as a fire precaution. Report value indicates source of alarm (from left): 1-4 Inverter 5-8 Rectifier.

**WARNING/ALARM 244, Start Delayed:**

Drive heatsink over temperature: Report value indicates source of alarm (from left): 1-4 Inverter 5-8 Rectifier.

**ALARM 245, Start Delayed:**

No feedback from the heatsink sensor Report value indicates source of alarm (from left): 1-4 Inverter 5-8 Rectifier.

**ALARM 246, Start Delayed:**

The supply on the power card is out of range Report value indicates source of alarm (from left): 1-4 Inverter 5-8 Rectifier.

**ALARM 247, Start Delayed:**

Power card over temperature Report value indicates source of alarm (from left): 1-4 Inverter 5-8 Rectifier.

**ALARM 248, Start Delayed:**

Power size configuration fault on the power card Report value indicates source of alarm (from left): 1-4 Inverter 5-8 Rectifier.

**ALARM 250, New Spare Part:**

The power or Switch Mode Power Supply has been exchanged. The frequency converter type code must be restored in the EEPROM. Select the correct type code in Par 14-23 according to the label on unit. Remember to select 'Save to EEPROM' to complete.

**ALARM 251, New Type Code:**

The frequency converter has got a new type code.

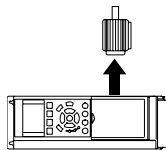
## 10 Specifications

### 10.1 General Specifications

**10.1.1 Mains Supply 1 x 200 - 240 VAC**

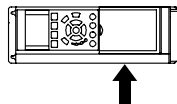
**Mains Supply 1 x 200 - 240 VAC - Normal overload 110% for 1 minute**

Frequency converter Typical Shaft Output [kW]	P1K1	P1K5	P2K2	P3K0	P3K7	P5K5	P7K5	P15K0	P22K0
IP 20 / Chassis	1.1	1.5	2.2	3.0	3.7	5.5	7.5	15	22
IP 21 / NEMA 1	1.5	2.0	2.9	4.0	4.9	7.5	10	20	30
IP 55 / NEMA 12	A3	-	-	-	-	-	-	-	-
IP 66	-	B1	B1	B1	B1	B1	B2	C1	C2
	A5	B1	B1	B1	B1	B1	B2	C1	C2
	A5	B1	B1	B1	B1	B1	B2	C1	C2
<b>Output current</b>									
Continuous (3 x 200-240 V) [A]	6.6	7.5	10.6	12.5	16.7	24.2	30.8	59.4	88
Intermittent (3 x 200-240 V) [A]	7.3	8.3	11.7	13.8	18.4	26.6	33.4	65.3	96.8
Continuous kVA (208 V AC) [kVA]						5.00	6.40	12.27	18.30
Max. cable size: (mains, motor, brake) [[mm <sup>2</sup> / AWG] <sup>2)</sup>			0.2-4 / 4-10			10/7	35/2	50/1/0	95/4/0



**Max. input current**

Continuous (1 x 200-240 V) [A]	12.5	15	20.5	24	32	46	59	111	172
Intermittent (1 x 200-240 V) [A]	13.8	16.5	22.6	26.4	35.2	50.6	64.9	122.1	189.2
Max. pre-fuses <sup>1)</sup> [A]	20	30	40	40	60	80	100	150	200
Environment									
Estimated power loss at rated max. load [W] <sup>4)</sup>	44	30	44	60	74	110	150	300	440
Weight enclosure IP 20 [kg]	4.9	-	-	-	-	-	-	-	-
Weight enclosure IP 21 [kg]	-	23	23	23	23	23	27	45	65
Weight enclosure IP 55 [kg]	-	23	23	23	23	23	27	45	65
Weight enclosure IP 66 [kg]	-	23	23	23	23	23	27	45	65
Efficiency <sup>3)</sup>	0.968	0.98	0.98	0.98	0.98	0.98	0.98	0.98	0.98



### 10.1.1.2 Mains Supply 3 x 200 - 240 VAC

**Normal overload 110% for 1 minute**

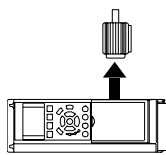
IP 20 / NEMA Chassis	A2	A2	A2	A2	A2	A2	A2	A2	A2	A2	A2	A2	A3	A3
IP 21 / NEMA 1	A2	A2	A2	A2	A2	A2	A2	A2	A2	A2	A2	A2	A3	A3
IP 55 / NEMA 12	A5	A5	A5	A5	A5	A5	A5	A5	A5	A5	A5	A5	A5	A5
IP 66	A5	A5	A5	A5	A5	A5	A5	A5	A5	A5	A5	A5	A5	A5

**Mains supply 200 - 240 VAC**

Frequency converter	PK25	PK37	PK55	PK75	P1K1	P1K5	P2K2	P3K0	P3K7
Typical Shaft Output [kW]	0.25	0.37	0.55	0.75	1.1	1.5	2.2	3	3.7
Typical Shaft Output [HP] at 208 V	0.25	0.37	0.55	0.75	1.5	2.0	2.9	4.0	4.9

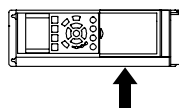
**Output current**

Continuous (3 x 200-240 V) [A]	1.8	2.4	3.5	4.6	6.6	7.5	10.6	12.5	16.7	
Intermittent (3 x 200-240 V) [A]	1.98	2.64	3.85	5.06	7.26	8.3	11.7	13.8	18.4	
Continuous kVA (208 V AC) [kVA]	0.65	0.86	1.26	1.66	2.38	2.70	3.82	4.50	6.00	
Max. cable size: (mains, motor, brake) [mm <sup>2</sup> / AWG] <sup>2)</sup>	0.2 - 4 mm <sup>2</sup> / 4 - 10 AWG									



**Max. input current**

Continuous (3 x 200-240 V) [A]	1.6	2.2	3.2	4.1	5.9	6.8	9.5	11.3	15.0	
Intermittent (3 x 200-240 V) [A]	1.7	2.42	3.52	4.51	6.5	7.5	10.5	12.4	16.5	
Max. pre-fuses <sup>1)</sup> [A]	10	10	10	10	20	20	20	32	32	
Environment	Estimated power loss at rated max. load [W] <sup>4)</sup>									
Weight enclosure IP20 [kg]	21	29	42	54	63	82	116	155	185	
Weight enclosure IP21 [kg]	4.9	4.9	4.9	4.9	4.9	4.9	4.9	6.6	6.6	
Weight enclosure IP55 [kg]	5.5	5.5	5.5	5.5	5.5	5.5	5.5	7.5	7.5	
Weight enclosure IP66 [kg]	13.5	13.5	13.5	13.5	13.5	13.5	13.5	13.5	13.5	
Efficiency <sup>3)</sup>	0.94	0.94	0.95	0.95	0.96	0.96	0.96	0.96	0.96	



10

**Mains supply 3 x 200 - 240 VAC - Normal overload 110% for 1 minute**

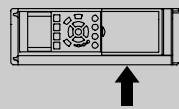
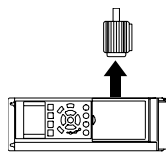
	B3	B3	B3	B4	B4	C3	C3	C4	C4
IP 20 / NEMA Chassis (B3+4 and C3+4 may be converted to IP21 using a conversion kit (Please contact Danfoss))	B3	B3	B3	B4	B4	C3	C3	C4	C4
IP 21 / NEMA 1	B1	B1	B1	B2	B2	C1	C1	C2	C2
IP 55 / NEMA 12	B1	B1	B1	B2	B2	C1	C1	C2	C2
IP 66	B1	B1	B1	B2	B2	C1	C1	C2	C2
Frequency converter	P5K5	P7K5	P11K	P15K	P18K	P22K	P30K	P37K	P45K
Typical Shaft Output [kW]	5.5	7.5	11	15	18.5	22	30	37	45
Typical Shaft Output [HP] at 208 V	7.5	10	15	20	25	30	40	50	60
<b>Output current</b>									
	Continuous (3 x 200-240 V) [A]								
	Intermittent (3 x 200-240 V) [A]								
	Continuous kVA (208 V AC) [kVA]								
	Max. cable size: (mains, motor, brake) [mm <sup>2</sup> /AWG] <sup>2)</sup>								
<b>Max. input current</b>									
	Continuous (3 x 200-240 V) [A]								
	Intermittent (3 x 200-240 V) [A]								
	Max. pre-fuses <sup>1)</sup> [A]								
	Environment:								
	Estimated power loss at rated max. load [W] <sup>4)</sup>								
	Weight enclosure IP20 [kg]								
Weight enclosure IP21 [kg]									
Weight enclosure IP55 [kg]									
Weight enclosure IP 66 [kg]									
Efficiency <sup>3)</sup>									
	22.0	28.0	42.0	54.0	68.0	80.0	104.0	130.0	154.0
	24.2	30.8	46.2	59.4	74.8	88.0	114.0	143.0	169.0
	63	63	63	80	125	125	160	200	250
	269	310	447	602	737	845	1140	1353	1636
	12	12	12	23.5	23.5	35	35	50	50
	23	23	23	27	45	45	65	65	65
	23	23	23	27	45	45	65	65	65
	23	23	23	27	45	45	65	65	65
	0.96	0.96	0.96	0.96	0.96	0.97	0.97	0.97	0.97



### 10.1.3 Mains Supply 1 x 380 - 480 VAC

**Mains Supply 1x 380 VAC - Normal overload 110% for 1 minute**

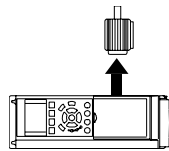
Frequency converter	P7K5	P11K	P18K	P37K
Typical Shaft Output [kW]	7.5	11	18.5	37
Typical Shaft Output [HP] at 460 V	10	15	25	50
IP 21 / NEMA 1	B1	B2	C1	C2
IP 55 / NEMA 12	B1	B2	C1	C2
IP 66	B1	B2	C1	C2
<b>Output current</b>				
Continuous (3 x 380-440 V) [A]	16	24	37.5	73
Intermittent (3 x 380-440 V) [A]	17.6	26.4	41.2	80.3
Continuous (3 x 441-480 V) [A]	14.5	21	34	65
Intermittent (3 x 441-480 V) [A]	15.4	23.1	37.4	71.5
Continuous kVA (400 V AC) [kVA]	11.0	16.6	26	50.6
Continuous kVA (460 V AC) [kVA]	11.6	16.7	27.1	51.8
Max. cable size: (mains, motor, brake) [[mm <sup>2</sup> / AWG] <sup>2</sup> ]	10/7	35/2	50/1/0	120/4/0
<b>Max. input current</b>				
Continuous (1 x 380-440 V) [A]	33	48	78	151
Intermittent (1 x 380-440 V) [A]	36	53	85.8	166
Continuous (1 x 441-480 V) [A]	30	41	72	135
Intermittent (1 x 441-480 V) [A]	33	46	79.2	148
Max. pre-fuses <sup>1)</sup> [A]	63	80	160	250
Environment				
Estimated power loss at rated max. load [W] <sup>4)</sup>	300	440	740	1480
Weight enclosure IP 21 [kg]	23	27	45	65
Weight enclosure IP 55 [kg]	23	27	45	65
Weight enclosure IP 66 [kg]	23	27	45	65
Efficiency <sup>3)</sup>	0.96	0.96	0.96	0.96



### 10.1.4 Mains Supply 3 x 380 - 480 VAC

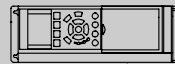
#### Mains Supply 3 x 380 - 480 VAC - Normal overload 110% for 1 minute

Frequency converter	PK37	PK55	PK75	PK11	PK15	P2K2	P3K0	P4K0	P5K5	P7K5
Typical Shaft Output [kW]	0.37	0.55	0.75	1.1	1.5	2.2	3	4	5.5	7.5
Typical Shaft Output [HP] at 460 V	0.5	0.75	1.0	1.5	2.0	2.9	4.0	5.3	7.5	10
IP 20 / NEMA Chassis	A2	A2	A2	A2	A2	A2	A2	A2	A3	A3
IP 21 / NEMA 1	A5	A5	A5	A5	A5	A5	A5	A5	A5	A5
IP 55 / NEMA 12	A5	A5	A5	A5	A5	A5	A5	A5	AA	A5
IP 66										
<b>Output current</b>										
Continuous (3 x 380-440 V) [A]	1.3	1.8	2.4	3	4.1	5.6	7.2	10	13	16
Intermittent (3 x 380-440 V) [A]	1.43	1.98	2.64	3.3	4.5	6.2	7.9	11	14.3	17.6
Continuous (3 x 441-480 V) [A]	1.2	1.6	2.1	2.7	3.4	4.8	6.3	8.2	11	14.5
Intermittent (3 x 441-480 V) [A]	1.32	1.76	2.31	3.0	3.7	5.3	6.9	9.0	12.1	15.4
Continuous kVA (400 V AC) [kVA]	0.9	1.3	1.7	2.1	2.8	3.9	5.0	6.9	9.0	11.0
Continuous kVA (460 V AC) [kVA]	0.9	1.3	1.7	2.4	2.7	3.8	5.0	6.5	8.8	11.6
Max. cable size: (mains, motor, brake) [[mm <sup>2</sup> / AWG] <sup>2)</sup>	4/10									



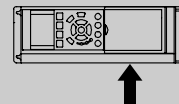
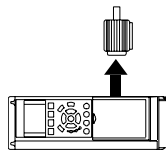
#### Max. input current

Continuous (3 x 380-440 V) [A]	1.2	1.6	2.2	2.7	3.7	5.0	6.5	9.0	11.7	14.4
Intermittent (3 x 380-440 V) [A]	1.32	1.76	2.42	3.0	4.1	5.5	7.2	9.9	12.9	15.8
Continuous (3 x 441-480 V) [A]	1.0	1.4	1.9	2.7	3.1	4.3	5.7	7.4	9.9	13.0
Intermittent (3 x 441-480 V) [A]	1.1	1.54	2.09	3.0	3.4	4.7	6.3	8.1	10.9	14.3
Max. pre-fuses <sup>1)</sup> [A]	10	10	10	10	10	20	20	20	30	30
Environment										
Estimated power loss at rated max. load [W] <sup>4)</sup>	35	42	46	58	62	88	116	124	187	255
Weight enclosure IP 20 [kg]	4.7	4.7	4.8	4.8	4.9	4.9	4.9	4.9	6.6	6.6
Weight enclosure IP 21 [kg]	13.5	13.5	13.5	13.5	13.5	13.5	13.5	13.5	14.2	14.2
Weight enclosure IP 55 [kg]	13.5	13.5	13.5	13.5	13.5	13.5	13.5	13.5	14.2	14.2
Weight enclosure IP 66 [kg]	0.93	0.95	0.96	0.96	0.97	0.97	0.97	0.97	0.97	0.97
Efficiency <sup>3)</sup>										



**Mains Supply 3 x 380 - 480 VAC - Normal overload 110% for 1 minute**

Frequency converter Typical Shaft Output [kW]	P11K 11	P15K 15	P18K 18.5	P22K 22	P30K 30	P37K 37	P45K 45	P55K 55	P75K 75	P90K 90	
Typical Shaft Output [HP] at 460 V	15	20	25	30	40	50	60	75	100	125	
IP 20 / NEMA Chassis (B3+4 and C3+4 may be converted to IP21 using a conversion kit (Please contact Danfoss))	B3	B3	B3	B4	B4	B4	C3	C3	C4	C4	
IP 21 / NEMA 1	B1	B1	B1	B2	B2	C1	C1	C1	C2	C2	
IP 55 / NEMA 12	B1	B1	B1	B2	B2	C1	C1	C1	C2	C2	
IP 66	B1	B1	B1	B2	B2	C1	C1	C1	C2	C2	
<b>Output current</b>											
Continuous (3 x 380-440 V) [A]	24	32	37.5	44	61	73	90	106	147	177	
Intermittent (3 x 380-440 V) [A]	26.4	35.2	41.3	48.4	67.1	80.3	99	117	162	195	
Continuous (3 x 441-480 V) [A]	21	27	34	40	52	65	80	105	130	160	
Intermittent (3 x 441-480 V) [A]	23.1	29.7	37.4	44	61.6	71.5	88	116	143	176	
Continuous kVA (400 V AC) [kVA]	16.6	22.2	26	30.5	42.3	50.6	62.4	73.4	102	123	
Continuous kVA (460 V AC) [kVA]	16.7	21.5	27.1	31.9	41.4	51.8	63.7	83.7	104	128	
Max. cable size: (mains, motor, brake) [[mm <sup>2</sup> / AWG] <sup>2)</sup>	10/7			35/2			50/1/0			120/4/0	
<b>Max. input current</b>											
Continuous (3 x 380-440 V) [A]	22	29	34	40	55	66	82	96	133	161	
Intermittent (3 x 380-440 V) [A]	24.2	31.9	37.4	44	60.5	72.6	90.2	106	146	177	
Continuous (3 x 441-480 V) [A]	19	25	31	36	47	59	73	95	118	145	
Intermittent (3 x 441-480 V) [A]	20.9	27.5	34.1	39.6	51.7	64.9	80.3	105	130	160	
Max. pre-fuses <sup>1)</sup> [A]	63	63	63	63	80	100	125	160	250	250	
Environment											
Estimated power loss at rated max. load [W] <sup>4)</sup>	278	392	465	525	698	739	843	1083	1384	1474	
Weight enclosure IP20 [kg]	12	12	12	23.5	23.5	23.5	35	35	50	50	
Weight enclosure IP 21 [kg]	23	23	23	27	27	45	45	45	65	65	
Weight enclosure IP 55 [kg]	23	23	23	27	27	45	45	45	65	65	
Weight enclosure IP 66 [kg]	23	23	23	27	27	45	45	45	65	65	
Efficiency <sup>3)</sup>	0.98	0.98	0.98	0.98	0.98	0.98	0.98	0.98	0.98	0.99	



**Normal overload 110% for 1 minute**

Frequency converter	P110	P132	P160	P200	P250	315	P400	P450	P500	P560	P630	P710	P800	P1M0
Typical Shaft Output [kW] at 400V	110	132	160	200	250	315	400	450	500	560	630	710	800	1000
Typical Shaft Output [HP] at 460V	150	200	250	300	350	450	550	600	650	750	900	1000	1200	1350
IP 00	D3	D3	D4	D4	D4	E2	E2	E2	F1/F3	F1/F3	F1/F3	F1/F3	F2/F4	F2/F4
IP 21 / Nema 1	D1	D1	D2	D2	D2	E1	E1	E1	F1/F3	F1/F3	F1/F3	F1/F3	F2/F4	F2/F4
IP 54 / Nema 12	D1	D1	D2	D2	D2	E1	E1	E1	F1/F3	F1/F3	F1/F3	F1/F3	F2/F4	F2/F4

**Output current**

Continuous (3 x 380-440 V) [A]	212	260	315	395	480	600	745	800	880	990	1120	1260	1460	1720
Intermittent (3 x 380-440 V) [A]	233	286	347	435	528	660	820	880	968	1089	1232	1386	1606	1892
Continuous (3 x 441-480V) [A]	190	240	302	361	443	540	678	730	780	890	1050	1160	1380	1530
Intermittent (3 x 441-480V) [A]	209	264	332	397	487	594	746	803	858	979	1155	1276	1518	1683
Continuous kVA (400 VAC) [kVA]	147	180	218	274	333	416	516	554	610	686	776	873	1012	1192
Continuous kVA (460 VAC) [kVA]	151	191	241	288	353	430	540	582	621	709	837	924	1100	1219

Max. cable size:

( motor, ) [mm <sup>2</sup> / AWG <sup>2</sup> ]	2x70 2x2/0	2x70 2x2/0	2x185 2x300 mcm	2x185 2x300 mcm	2x185 2x300 mcm	4x240 4x500 mcm	4x240 4x500 mcm	8x150 8x300 mcm	8x150 8x300 mcm	12x150 12x300 mcm
( mains, ) [mm <sup>2</sup> / AWG <sup>2</sup> ]	2x70 2x2/0	2x70 2x2/0	2x185 2x300 mcm	2x185 2x300 mcm	2x185 2x300 mcm	4x240 4x500 mcm	4x240 4x500 mcm	8x240 8x500 mcm	8x240 8x500 mcm	12x150 12x300 mcm
(loadsharing) [mm <sup>2</sup> / AWG <sup>2</sup> ]	2x70 2x2/0	2x70 2x2/0	2x185 2x300 mcm	2x185 2x300 mcm	2x185 2x300 mcm	4x240 4x500 mcm	4x240 4x500 mcm	8x240 8x500 mcm	8x240 8x500 mcm	12x150 12x300 mcm
( brake) [mm <sup>2</sup> / AWG <sup>2</sup> ]	2x70 2x2/0	2x70 2x2/0	2x185 2x300 mcm	2x185 2x300 mcm	2x185 2x300 mcm	4x185 4x350 mcm	4x185 4x350 mcm	6x185 6x350 mcm	6x185 6x350 mcm	12x150 12x300 mcm

**Max. input current**

Continuous (3 x 380-440 V) [A]	204	251	304	381	463	590	733	787	857	964	1090	1227	1422	1675
Continuous (3 x 441-480V) [A]	183	231	291	348	427	531	667	718	759	867	1022	1129	1344	1490
Max. pre-fuses <sup>1)</sup> [A]	300	350	400	500	630	700	900	900	1600	1600	2000	2000	2500	2500
Environment:	3334	3782	4213	5119	5893	6790	8879	9670	10647	12338	13201	15436	18084	20358
Estimated power loss at 400 VAC at rated max. load [W] <sup>4)</sup>	2947	3665	4063	4652	5634	6082	8089	8803	9414	11006	12353	14041	17137	17752
Estimated power loss at 460 VAC at rated max. load [W] <sup>4)</sup>	82	91	112	123	138	221	236	277	-	-	-	-	-	-
Weight enclosure IP00 [kg]	96	104	125	136	151	263	272	313	1004	1004	1004	1004	1246	1246
Weight enclosure IP 21 [kg]	96	104	125	136	151	263	272	313	1299	1299	1299	1299	1541	1541
Weight enclosure IP 54 [kg]	0.98	0.98	0.98	0.98	0.98	0.98	0.98	0.98	0.98	0.98	0.98	0.98	0.98	0.98

<sup>1)</sup> For type of fuse see section Fuses

<sup>2)</sup> American Wire Gauge

<sup>3)</sup> Measured using 5 m screened motor cables at rated load and rated frequency

<sup>4)</sup> The typical power loss is at normal load conditions and expected to be within +/- 15% (tolerance relates to variety in voltage and cable conditions).

Values are based on a typical motor efficiency (eff2/eff3 border line). Lower efficiency motors will also add to the power loss in the frequency converter and vice versa.

If the switching frequency is raised from nominal the power losses may rise significantly.

LCP and typical control card power consumptions are included. Further options and customer load may add up to 30 Watts to the losses. (Though typically only 4 Watts extra for a fully loaded control card or options for slot A or slot B, each).

Although measurements are made with state of the art equipment, some measurement inaccuracy must be allowed for (+/- 5%).

### 10.1.5 Mains Supply 3 x 525 - 600 VAC

Normal overload 110% for 1 minute		PK75	P1K1	P1K5	P2K2	P3K0	P4K0	P5K5	P7K5	P11K	P15K	P18K	P22K	P30K	P37K	P45K	P55K	P75K	P90K	
Size:		0.75	1.1	1.5	2.2	3	4	5.5	7.5	11	15	18.5	22	30	37	45	55	75	90	
Typical Shaft Output [kW]		A2	A2	A2	A2	A2	A2	A3	A3	B3	B3	B3	B4	B4	B4	C3	C3	C4	C4	
IP 20 / NEMA Chassis		A2	A2	A2	A2	A2	A2	A3	A3	B1	B1	B1	B2	B2	B2	C1	C1	C2	C2	
IP 21 / NEMA 1		A5	A5	A5	A5	A5	A5	A5	A5	B1	B1	B1	B2	B2	B2	C1	C1	C2	C2	
IP 55 / NEMA 12		A5	A5	A5	A5	A5	A5	A5	A5	B1	B1	B1	B2	B2	B2	C1	C1	C2	C2	
IP 66		A5	A5	A5	A5	A5	A5	A5	A5	B1	B1	B1	B2	B2	B2	C1	C1	C2	C2	
<b>Output current</b>																				
Continuous (3 x 525-550 V) [A]		1.8	2.6	2.9	4.1	5.2	6.4	9.5	11.5	19	23	28	36	43	54	65	87	105	137	
Intermittent (3 x 525-550 V) [A]		2.9	3.2	3.2	4.5	5.7	7.0	10.5	12.7	21	25	31	40	47	59	72	96	116	151	
Continuous (3 x 525-600 V) [A]		1.7	2.4	2.7	3.9	4.9	6.1	9.0	11.0	18	22	27	34	41	52	62	83	100	131	
Intermittent (3 x 525-600 V) [A]		2.6	3.0	3.0	4.3	5.4	6.7	9.9	12.1	20	24	30	37	45	57	68	91	110	144	
Continuous kVA (525 V AC) [kVA]		1.7	2.5	2.8	3.9	5.0	6.1	9.0	11.0	18.1	21.9	26.7	34.3	41	51.4	61.9	82.9	100	130.5	
Continuous kVA (575 V AC) [kVA]		1.7	2.4	2.7	3.9	4.9	6.1	9.0	11.0	17.9	21.9	26.9	33.9	40.8	51.8	61.7	82.7	99.6	130.5	
Max. cable size (mains, motor, brake) [AWG] <sup>2)</sup> [mm <sup>2</sup> ]		24 - 10 AWG 0.2 - 4																		
<b>Max. input current</b>																				
Continuous (3 x 525-600 V) [A]		1.7	2.4	2.7	4.1	5.2	5.8	8.6	10.4	17.2	20.9	25.4	32.7	39	49	59	78.9	95.3	124.3	
Intermittent (3 x 525-600 V) [A]		2.7	3.0	3.0	4.5	5.7	6.4	9.5	11.5	19	23	28	36	43	54	65	87	105	137	
Max. pre-fuses <sup>3)</sup> [A]		10	10	10	20	20	20	32	32	40	40	50	60	80	100	150	160	225	250	
Environment:																				
Estimated power loss at rated max. load [W] <sup>4)</sup>		35	50	65	92	122	145	195	261	225	285	329	460	560	740	860	890	1020	1130	
Weight [kg]:																				
Enclosure IP20		6.5	6.5	6.5	6.5	6.5	6.5	6.6	6.6	12	12	12	23.5	23.5	23.5	35	35	50	50	
Efficiency <sup>4)</sup>		0.97	0.97	0.97	0.97	0.97	0.97	0.97	0.97	0.98	0.98	0.98	0.98	0.98	0.98	0.98	0.98	0.98	0.98	

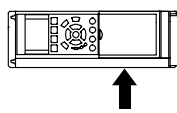
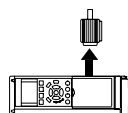


Table 10.1: <sup>5)</sup> Motor and mains cable: 300MCM/150mm<sup>2</sup>

10

10.1.6 Mains Supply 3 x 525 - 690 VAC

Normal overload 110% for 1 minute												
Size:	P11K	P15K	P18K	P22K	P30K	P37K	P45K	P55K	P75K	P90K		
Typical Shaft Output [kW]	11	15	18.5	22	30	37	45	55	75	90		
Typical Shaft Output [HP] at 575 V	10	16.4	20.1	24	33	40	50	60	75	100		
IP 21 / NEMA 1	B2	B2	B2	B2	B2	C2	C2	C2	C2	C2		
IP 55 / NEMA 12	B2	B2	B2	B2	B2	C2	C2	C2	C2	C2		
<b>Output current</b>												
Continuous (3 x 525-550 V) [A]	14	19	23	28	36	43	54	65	87	105		
Intermittent (3 x 525-550 V) [A]	15.4	20.9	25.3	30.8	39.6	47.3	59.4	71.5	95.7	115.5		
Continuous (3 x 551-690 V) [A]	13	18	22	27	34	41	52	62	83	100		
Intermittent (3 x 551-690 V) [A]	14.3	19.8	24.2	29.7	37.4	45.1	57.2	68.2	91.3	110		
Continuous kVA (550 V AC) [kVA]	13.3	18.1	21.9	26.7	34.3	41	51.4	61.9	82.9	100		
Continuous kVA (575 V AC) [kVA]	12.9	17.9	21.9	26.9	33.8	40.8	51.8	61.7	82.7	99.6		
Continuous kVA (690 V AC) [kVA]	15.5	21.5	26.3	32.3	40.6	49	62.1	74.1	99.2	119.5		
Max. cable size (mains, motor, brake) [mm <sup>2</sup> ]/[AWG] <sup>2)</sup>											95 4/0	
<b>Max. input current</b>												
Continuous (3 x 525-690 V) [A]	15	19.5	24	29	36	49	59	71	87	99		
Intermittent (3 x 525-690 V) [A]	16.5	21.5	26.4	31.9	39.6	53.9	64.9	78.1	95.7	108.9		
Max. pre-fuses <sup>1)</sup> [A]	60	60	60	60	60	150	150	150	150	150		
Environment:												
Estimated power loss at rated max. load [W] <sup>4)</sup>	201	285	335	375	430	592	720	880	1200	1440		
Weight:												
IP21 [kg]	27	27	27	27	27	65	65	65	65	65		
IP55 [kg]	27	27	27	27	27	65	65	65	65	65		
Efficiency <sup>4)</sup>	0.98	0.98	0.98	0.98	0.98	0.98	0.98	0.98	0.98	0.98		

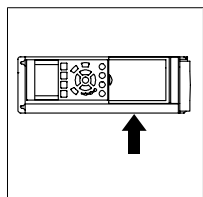
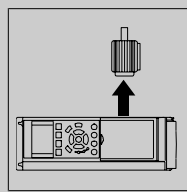


Table 10.2: <sup>5)</sup> Motor and mains cable: 300MCM/150mm<sup>2</sup>

### 10.1.7 Mains Supply 3 x 525 - 690 VAC

#### Normal overload 110% for 1 minute

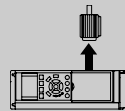
Frequency converter	P45K	P55K	P75K	P90K	P110	P132	P160	P200	P250	P315	P400	P450	P500	P560	P630	P710	P800	P900	P1M0	P1M2
Typical Shaft Output [kW]	45	55	75	90	110	132	160	200	250	315	400	450	500	560	630	710	800	900	1000	1200
Typical Shaft Output [HP] at 575 V	50	60	75	100	125	150	200	250	300	350	400	450	500	560	630	710	800	900	1000	1200
IP 00	D3	D3	D3	D3	D3	D3	D3	D4	D4	D4	D4	E2	E2	E2	E2	-	-	-	-	-
IP 21 / Nema 1	D1	D1	D1	D1	D1	D1	D1	D2	D2	D2	D2	E1	E1	E1	E1	F1/F3 <sup>6)</sup>	F1/ F3 <sup>6)</sup>	F1/F3 <sup>6)</sup>	F2/ F4 <sup>6)</sup>	F2/ F4 <sup>6)</sup>
IP 54 / Nema 12	D1	D1	D1	D1	D1	D1	D1	D2	D2	D2	D2	E1	E1	E1	E1	F1/F3 <sup>6)</sup>	F1/ F3 <sup>6)</sup>	F1/F3 <sup>6)</sup>	F1/ F3 <sup>6)</sup>	F1/ F3 <sup>6)</sup>

#### Output current

Continuous (3 x 550 V) [A]	56	76	90	113	137	162	201	253	303	360	418	470	523	596	630	763	889	988	1108	1317
Intermittent (3 x 550 V) [A]	62	84	99	124	151	178	221	278	333	396	460	517	575	656	693	839	978	1087	1219	1449
Continuous (3 x 690V) [A]	54	73	86	108	131	155	192	242	290	344	400	450	500	570	630	730	850	945	1060	1260
Intermittent (3 x 690 V) [A]	59	80	95	119	144	171	211	266	319	378	440	495	550	627	693	803	935	1040	1166	1386
Continuous kVA (550 VAC) [kVA]	53	72	86	108	131	154	191	241	289	343	398	448	498	568	600	727	847	941	1056	1255
Continuous kVA (575 VAC) [kVA]	54	73	86	108	130	154	191	241	289	343	398	448	498	568	627	727	847	941	1056	1255
Continuous kVA (690 VAC <sup>1)</sup> [kVA]	65	87	103	129	157	185	229	289	347	411	478	538	598	681	753	872	1016	1129	1267	1506

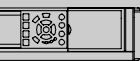
#### Max. cable size:

(Mains) [mm <sup>2</sup> / AWG] <sup>2)</sup>	2x70	2x70	2x70	2x70	2x70	2x70	2x70	2x185	2x300 mcm	2x300 mcm	2x300 mcm	2x300 mcm	4x240	4x500 mcm	4x500 mcm	8x240	8x500 mcm	8x500 mcm	8x500 mcm	8x240
(Motor) [mm <sup>2</sup> / AWG] <sup>2)</sup>	2x70	2x70	2x70	2x70	2x70	2x70	2x70	2x185	2x300 mcm	2x300 mcm	2x300 mcm	2x300 mcm	4x240	4x500 mcm	4x500 mcm	8x240	8x500 mcm	8x500 mcm	8x500 mcm	8x240
(Brake) [mm <sup>2</sup> / AWG] <sup>2)</sup>	2x70	2x70	2x70	2x70	2x70	2x70	2x70	2x185	2x300 mcm	2x300 mcm	2x300 mcm	2x300 mcm	2x185	2x350 mcm	2x350 mcm	4x185	4x350 mcm	4x350 mcm	4x350 mcm	4x185



#### Max. input current

Continuous (3 x 550 V) [A]	60	77	89	110	130	158	198	245	299	355	408	453	504	574	607	743	866	962	1079	1282
Continuous (3 x 575 V) [A]	58	74	85	106	124	151	189	224	286	339	390	434	482	549	607	711	828	920	1032	1227
Continuous (3 x 690 V) [A]	58	77	87	109	128	155	197	240	296	352	400	434	482	549	607	711	828	920	1032	1227
Max. mains pre-fuses <sup>1)</sup> [A]	125	160	200	200	250	315	350	350	400	500	550	700	700	900	900	2000	2000	2000	2000	2000



#### Environment:

Estimated power loss at 690 VAC at rated max. load [W] <sup>4)</sup>	1458	1717	1913	2262	2662	3430	3612	4292	5156	5821	6149	6440	7249	8727	9673	11315	12903	14533	16375	19207
Estimated power loss at 575 VAC at rated max. load [W] <sup>4)</sup>	1398	1645	1827	2157	2533	2963	3430	4051	4867	5493	5852	6132	6903	8343	9244	10771	12272	13835	15592	18281
Weight enclosure IP00 [kg]	82	82	82	82	82	82	91	112	123	138	151	221	221	236	277	-	-	-	-	-
Weight enclosure IP 21 [kg] <sup>6)</sup>	96	96	96	96	96	96	104	125	136	151	165	263	263	272	313	1004	1004	1004	1246	1246
Weight enclosure IP 54 [kg] <sup>6)</sup>	96	96	96	96	96	96	104	125	136	151	165	263	263	272	313	1004	1004	1004	1246	1246
Efficiency <sup>3)</sup>	0.97	0.97	0.98	0.98	0.98	0.98	0.98	0.98	0.98	0.98	0.98	0.98	0.98	0.98	0.98	0.98	0.98	0.98	0.98	0.98

<sup>1)</sup> For type of fuse see section Fuses

<sup>2)</sup> American Wire Gauge

<sup>3)</sup> Measured using 5 m screened motor cables at rated load and rated frequency

<sup>4)</sup> The typical power loss is at normal load conditions and expected to be within +/- 15% (tolerance relates to variety in voltage and cable conditions). Values are based on a typical motor efficiency (eff2/eff3 border line). Lower efficiency motors will also add to the power loss in the frequency converter and vice versa.

If the switching frequency is raised from nominal the power losses may rise significantly. LCP and typical control card power consumptions are included. Further options and customer load may add up to 30 [W] to the losses. (Though typically only 4 [W] extra for a fully loaded control card, or options for slot A or slot B, each).

Although measurements are made with state of the art equipment, some measurement inaccuracy must be allowed for (+/- 5%).

<sup>6)</sup> Adding the F-enclosure option cabinet (resulting in the F3 and F4 enclosure sizes) adds 295 kg to the estimated weight.

## Protection and Features:

- Electronic thermal motor protection against overload.
- Temperature monitoring of the heatsink ensures that the frequency converter trips if the temperature reaches  $95\text{ °C} \pm 5\text{ °C}$ . An overload temperature cannot be reset until the temperature of the heatsink is below  $70\text{ °C} \pm 5\text{ °C}$  (Guideline - these temperatures may vary for different power sizes, enclosures etc.). VLT AQUA Drive has an auto derating function to avoid it's heatsink reaching 95 deg C.
- The frequency converter is protected against short-circuits on motor terminals U, V, W.
- If a mains phase is missing, the frequency converter trips or issues a warning (depending on the load).
- Monitoring of the intermediate circuit voltage ensures that the frequency converter trips if the intermediate circuit voltage is too low or too high.
- The frequency converter is protected against earth faults on motor terminals U, V, W.

## Mains supply (L1, L2, L3):

Supply voltage	200-240 V $\pm 10\%$
Supply voltage	380-480 V $\pm 10\%$
Supply voltage	525-600 V $\pm 10\%$
Supply voltage	525-690 V $\pm 10\%$

*Mains voltage low / mains drop-out:*

*During low mains voltage or a mains drop-out, the FC continues until the intermediate circuit voltage drops below the minimum stop level, which corresponds typically to 15% below the FC's lowest rated supply voltage. Power-up and full torque cannot be expected at mains voltage lower than 10% below the FC's lowest rated supply voltage.*

Supply frequency	50/60 Hz +4/-6%
------------------	-----------------

*The frequency converter power supply is tested in accordance with IEC61000-4-28, 50 Hz +4/-6%.*

Max. imbalance temporary between mains phases	3.0 % of rated supply voltage
True Power Factor ( $\lambda$ )	$\geq 0.9$ nominal at rated load
Displacement Power Factor ( $\cos\phi$ ) near unity	(> 0.98)
Switching on input supply L1, L2, L3 (power-ups) $\leq$ enclosure type A	maximum 2 times/min.
Switching on input supply L1, L2, L3 (power-ups) $\geq$ enclosure type B, C	maximum 1 time/min.
Switching on input supply L1, L2, L3 (power-ups) $\geq$ enclosure type D, E, F	maximum 1 time/2 min.
Environment according to EN60664-1	overvoltage category III/pollution degree 2

*The unit is suitable for use on a circuit capable of delivering not more than 100.000 RMS symmetrical Amperes, 240/480 V maximum.*

## Motor output (U, V, W):

Output voltage	0 - 100% of supply voltage
Output frequency	0 - 1000 Hz*
Switching on output	Unlimited
Ramp times	1 - 3600 sec.

*\* Dependent on power size.*

## Torque characteristics:

Starting torque (Constant torque)	maximum 110% for 1 min.*
Starting torque	maximum 135% up to 0.5 sec.*
Overload torque (Constant torque)	maximum 110% for 1 min.*

*\*Percentage relates to VLT AQUA Drive's nominal torque.*

## Cable lengths and cross sections:

Max. motor cable length, screened/armoured	VLT AQUA Drive: 150 m
Max. motor cable length, unscreened/unarmoured	VLT AQUA Drive: 300 m
Max. cross section to motor, mains, load sharing and brake *	
Maximum cross section to control terminals, rigid wire	1.5 mm <sup>2</sup> /16 AWG (2 x 0.75 mm <sup>2</sup> )
Maximum cross section to control terminals, flexible cable	1 mm <sup>2</sup> /18 AWG
Maximum cross section to control terminals, cable with enclosed core	0.5 mm <sup>2</sup> /20 AWG
Minimum cross section to control terminals	0.25 mm <sup>2</sup>

*\* See Mains Supply tables for more information!*

## Control card, RS-485 serial communication:

Terminal number	68 (P,TX+, RX+), 69 (N,TX-, RX-)
Terminal number 61	Common for terminals 68 and 69

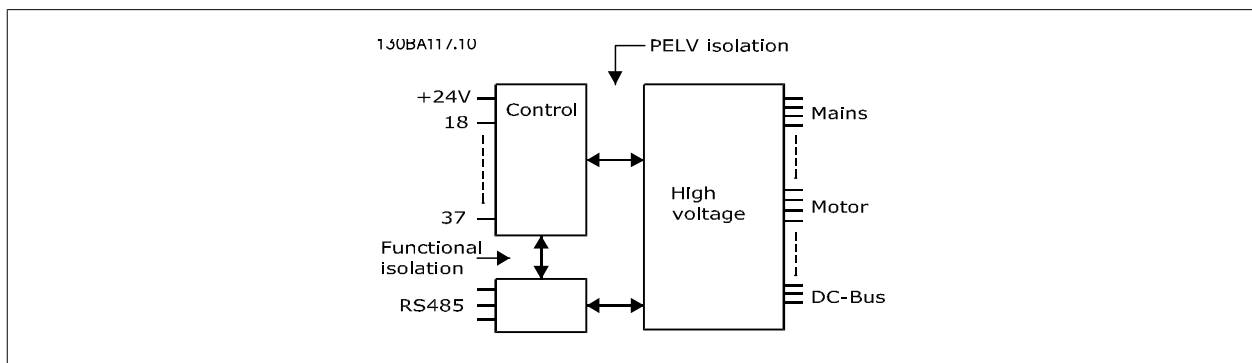
*The RS-485 serial communication circuit is functionally separated from other central circuits and galvanically isolated from the supply voltage (PELV).*



Analog inputs:

Number of analog inputs	2
Terminal number	53, 54
Modes	Voltage or current
Mode select	Switch S201 and switch S202
Voltage mode	Switch S201/switch S202 = OFF (U)
Voltage level	: 0 to + 10 V (scaleable)
Input resistance, R <sub>i</sub>	approx. 10 kΩ
Max. voltage	± 20 V
Current mode	Switch S201/switch S202 = ON (I)
Current level	0/4 to 20 mA (scaleable)
Input resistance, R <sub>i</sub>	approx. 200 Ω
Max. current	30 mA
Resolution for analog inputs	10 bit (+ sign)
Accuracy of analog inputs	Max. error 0.5% of full scale
Bandwidth	: 200 Hz

The analog inputs are galvanically isolated from the supply voltage (PELV) and other high-voltage terminals.



Analog output:

Number of programmable analog outputs	1
Terminal number	42
Current range at analog output	0/4 - 20 mA
Max. resistor load to common at analog output	500 Ω
Accuracy on analog output	Max. error: 0.8 % of full scale
Resolution on analog output	8 bit

The analog output is galvanically isolated from the supply voltage (PELV) and other high-voltage terminals.

Digital inputs:

Programmable digital inputs	4 (6)
Terminal number	18, 19, 27 <sup>1)</sup> , 29 <sup>1)</sup> , 32, 33,
Logic	PNP or NPN
Voltage level	0 - 24 V DC
Voltage level, logic '0' PNP	< 5 V DC
Voltage level, logic '1' PNP	> 10 V DC
Voltage level, logic '0' NPN	> 19 V DC
Voltage level, logic '1' NPN	< 14 V DC
Maximum voltage on input	28 V DC
Input resistance, R <sub>i</sub>	approx. 4 k

All digital inputs are galvanically isolated from the supply voltage (PELV) and other high-voltage terminals.

1) Terminals 27 and 29 can also be programmed as output.

## Digital output:

Programmable digital/pulse outputs	2
Terminal number	27, 29 <sup>1)</sup>
Voltage level at digital/frequency output	0 - 24 V
Max. output current (sink or source)	40 mA
Max. load at frequency output	1 k $\Omega$
Max. capacitive load at frequency output	10 nF
Minimum output frequency at frequency output	0 Hz
Maximum output frequency at frequency output	32 kHz
Accuracy of frequency output	Max. error: 0.1 % of full scale
Resolution of frequency outputs	12 bit

1) Terminal 27 and 29 can also be programmed as input.

The digital output is galvanically isolated from the supply voltage (PELV) and other high-voltage terminals.

## Pulse inputs:

Programmable pulse inputs	2
Terminal number pulse	29, 33
Max. frequency at terminal, 29, 33	110 kHz (Push-pull driven)
Max. frequency at terminal, 29, 33	5 kHz (open collector)
Min. frequency at terminal 29, 33	4 Hz
Voltage level	see section on Digital input
Maximum voltage on input	28 V DC
Input resistance, R <sub>i</sub>	approx. 4 k $\Omega$
Pulse input accuracy (0.1 - 1 kHz)	Max. error: 0.1% of full scale

## Control card, 24 V DC output:

Terminal number	12, 13
Max. load	: 200 mA

The 24 V DC supply is galvanically isolated from the supply voltage (PELV), but has the same potential as the analog and digital inputs and outputs.

## Relay outputs:

Programmable relay outputs	2
<b>Relay 01 Terminal number</b>	1-3 (break), 1-2 (make)
Max. terminal load (AC-1) <sup>1)</sup> on 1-3 (NC), 1-2 (NO) (Resistive load)	240 V AC, 2 A
Max. terminal load (AC-15) <sup>1)</sup> (Inductive load @ cos $\phi$ 0.4)	240 V AC, 0.2 A
Max. terminal load (DC-1) <sup>1)</sup> on 1-2 (NO), 1-3 (NC) (Resistive load)	60 V DC, 1 A
Max. terminal load (DC-13) <sup>1)</sup> (Inductive load)	24 V DC, 0.1 A
<b>Relay 02 Terminal number</b>	4-6 (break), 4-5 (make)
Max. terminal load (AC-1) <sup>1)</sup> on 4-5 (NO) (Resistive load) <sup>2)3)</sup>	400 V AC, 2 A
Max. terminal load (AC-15) <sup>1)</sup> on 4-5 (NO) (Inductive load @ cos $\phi$ 0.4)	240 V AC, 0.2 A
Max. terminal load (DC-1) <sup>1)</sup> on 4-5 (NO) (Resistive load)	80 V DC, 2 A
Max. terminal load (DC-13) <sup>1)</sup> on 4-5 (NO) (Inductive load)	24 V DC, 0.1 A
Max. terminal load (AC-1) <sup>1)</sup> on 4-6 (NC) (Resistive load)	240 V AC, 2 A
Max. terminal load (AC-15) <sup>1)</sup> on 4-6 (NC) (Inductive load @ cos $\phi$ 0.4)	240 V AC, 0.2 A
Max. terminal load (DC-1) <sup>1)</sup> on 4-6 (NC) (Resistive load)	50 V DC, 2 A
Max. terminal load (DC-13) <sup>1)</sup> on 4-6 (NC) (Inductive load)	24 V DC, 0.1 A
Min. terminal load on 1-3 (NC), 1-2 (NO), 4-6 (NC), 4-5 (NO)	24 V DC 10 mA, 24 V AC 20 mA
Environment according to EN 60664-1	overvoltage category III/pollution degree 2

1) IEC 60947 part 4 and 5

The relay contacts are galvanically isolated from the rest of the circuit by reinforced isolation (PELV).

2) Overvoltage Category II

3) UL applications 300 V AC 2A

## Control card, 10 V DC output:

Terminal number	50
Output voltage	10.5 V $\pm$ 0.5 V
Max. load	25 mA

The 10 V DC supply is galvanically isolated from the supply voltage (PELV) and other high-voltage terminals.

Control characteristics:

Resolution of output frequency at 0 - 1000 Hz	: +/- 0.003 Hz
System response time (terminals 18, 19, 27, 29, 32, 33)	: ≤ 2 ms
Speed control range (open loop)	1:100 of synchronous speed
Speed accuracy (open loop)	30 - 4000 rpm: Maximum error of ±8 rpm

*All control characteristics are based on a 4-pole asynchronous motor*

Surroundings:

Enclosure type A	IP 20/Chassis, IP 21kit/Type 1, IP55/Type12, IP 66
Enclosure type B1/B2	IP 21/Type 1, IP55/Type12, IP 66
Enclosure type B3/B4	IP20/Chassis
Enclosure type C1/C2	IP 21/Type 1, IP55/Type 12, IP66
Enclosure type C3/C4	IP20/Chassis
Enclosure type D1/D2/E1	IP21/Type 1, IP54/Type12
Enclosure type D3/D4/E2	IP00/Chassis
Enclosure kit available ≤ enclosure type A	IP21/TYPE 1/IP 4X top
Vibration test enclosure A/B/C	1.0 g
Vibration test enclosure D/E/F	0.7 g
Max. relative humidity	5% - 95%(IEC 721-3-3; Class 3K3 (non-condensing) during operation
Aggressive environment (IEC 721-3-3), uncoated	class 3C2
Aggressive environment (IEC 721-3-3), coated	class 3C3
Test method according to IEC 60068-2-43 H2S (10 days)	
Ambient temperature	Max. 50 °C

*Derating for high ambient temperature, see section on special conditions*

Minimum ambient temperature during full-scale operation	0 °C
Minimum ambient temperature at reduced performance	- 10 °C
Temperature during storage/transport	-25 - +65/70 °C
Maximum altitude above sea level without derating	1000 m
Maximum altitude above sea level with derating	3000 m

*Derating for high altitude, see section on special conditions*

EMC standards, Emission	EN 61800-3, EN 61000-6-3/4, EN 55011, IEC 61800-3 EN 61800-3, EN 61000-6-1/2,
EMC standards, Immunity	EN 61000-4-2, EN 61000-4-3, EN 61000-4-4, EN 61000-4-5, EN 61000-4-6

*See section on special conditions*

Control card performance:

Scan interval	: 5 ms
Control card, USB serial communication:	
USB standard	1.1 (Full speed)
USB plug	USB type B "device" plug



Connection to PC is carried out via a standard host/device USB cable.  
The USB connection is galvanically isolated from the supply voltage (PELV) and other high-voltage terminals.  
The USB connection is not galvanically isolated from protection earth. Use only isolated laptop/PC as connection to the USB connector on VLT AQUA Drive or an isolated USB cable/converter.

## 10.2 Efficiency

### Efficiency of VLT AQUA ( $\eta_{VLT}$ )

The load on the frequency converter has little effect on its efficiency. In general, the efficiency is the same at the rated motor frequency  $f_{M,N}$ , even if the motor supplies 100% of the rated shaft torque or only 75%, i.e. in case of part loads.

This also means that the efficiency of the frequency converter does not change even if other U/f characteristics are chosen. However, the U/f characteristics influence the efficiency of the motor.

The efficiency declines a little when the switching frequency is set to a value of above 5 kHz. The efficiency will also be slightly reduced if the mains voltage is 480 V, or if the motor cable is longer than 30 m.

### Efficiency of the motor ( $\eta_{MOTOR}$ )

The efficiency of a motor connected to the frequency converter depends on magnetising level. In general, the efficiency is just as good as with mains operation. The efficiency of the motor depends on the type of motor.

In the range of 75-100% of the rated torque, the efficiency of the motor is practically constant, both when it is controlled by the frequency converter and when it runs directly on mains.

In small motors, the influence from the U/f characteristic on efficiency is marginal. However, in motors from 11 kW and up, the advantages are significant.

In general, the switching frequency does not affect the efficiency of small motors. Motors from 11 kW and up have their efficiency improved (1-2%). This is because the sine shape of the motor current is almost perfect at high switching frequency.

### Efficiency of the system ( $\eta_{SYSTEM}$ )

To calculate the system efficiency, the efficiency of VLT AQUA ( $\eta_{VLT}$ ) is multiplied by the efficiency of the motor ( $\eta_{MOTOR}$ ):

$$\eta_{SYSTEM} = \eta_{VLT} \times \eta_{MOTOR}$$

Calculate the efficiency of the system at different loads based on the graph above.

## 10.3 Acoustic noise

The acoustic noise from the frequency converter comes from three sources:

1. DC intermediate circuit coils.
2. Integral fan.
3. RFI filter choke.

The typical values measured at a distance of 1 m from the unit:

Enclosure	At reduced fan speed (50%) [dBA] ***	Full fan speed [dBA]
A2	51	60
A3	51	60
A5	54	63
B1	61	67
B2	58	70
B3	59.4	70.5
B4	53	62.8
C1	52	62
C2	55	65
C3	56.4	67.3
C4	-	-
D1+D3	74	76
D2+D4	73	74
E1/E2 *	73	74
E1/E2 **	82	83
F1/F2/F3/F4	78	80

\* 315 kW, 380-480 VAC and 450/500 kW, 525-690 VAC only!  
 \*\* Remaining E1+E2 power sizes.  
 \*\*\* For D, E and F sizes, reduced fan speed is at 87%, measured at 200 V.

## 10.4 Peak voltage on motor

**When a transistor in the inverter bridge switches, the voltage across the motor increases by a du/dt ratio depending on:**

- the motor cable (type, cross-section, length screened or unscreened)
- inductance

The natural induction causes an overshoot  $U_{PEAK}$  in the motor voltage before it stabilizes itself at a level depending on the voltage in the intermediate circuit. The rise time and the peak voltage  $U_{PEAK}$  affect the service life of the motor. If the peak voltage is too high, especially motors without phase coil insulation are affected. If the motor cable is short (a few metres), the rise time and peak voltage are lower.

If the motor cable is long (100 m), the rise time and peak voltage increases.

In motors without phase insulation paper or other insulation reinforcement suitable for operation with voltage supply (such as a frequency converter), fit a sine-wave filter on the output of the frequency converter.

To obtain approximate values for cable lengths and voltages not mentioned below, use the following rules of thumb:

1. Rise time increases/decreases proportionally with cable length.
2.  $U_{PEAK} = \text{DC link voltage} \times 1.9$   
(DC link voltage = Mains voltage  $\times$  1.35).
3. 
$$\frac{dU}{dt} = \frac{0.8 \times U_{PEAK}}{\text{Risetime}}$$

Data are measured according to IEC 60034-17.

Cable lengths are in metres.

<b>FC 202, P7K5T2</b>				
Cable length [m]	Mains voltage [V]	Rise time [ $\mu\text{sec}$ ]	Vpeak [kV]	dU/dt [kV/ $\mu\text{sec}$ ]
5	230	0.13	0.510	3.090
50	230	0.23		2.034
100	230	0.54	0.580	0.865
150	230	0.66	0.560	0.674

<b>FC 202, P11KT2</b>				
Cable length [m]	Mains voltage [V]	Rise time [ $\mu\text{sec}$ ]	Vpeak [kV]	dU/dt [kV/ $\mu\text{sec}$ ]
36	240	0.264	0.624	1.890
136	240	0.536	0.596	0.889
150	240	0.568	0.568	0.800

<b>FC 202, P15KT2</b>				
Cable length [m]	Mains voltage [V]	Rise time [ $\mu\text{sec}$ ]	Vpeak [kV]	dU/dt [kV/ $\mu\text{sec}$ ]
30	240	0.556	0.650	0.935
100	240	0.592	0.594	0.802
150	240	0.708	0.587	0.663

**FC 202, P18KT2**

Cable length [m]	Mains voltage [V]	Rise time [ $\mu$ sec]	Vpeak [kV]	dU/dt [kV/ $\mu$ sec]
36	240	0.244	0.608	1.993
136	240	0.568	0.580	0.816
150	240	0.720	0.574	0.637

**FC 202, P22KT2**

Cable length [m]	Mains voltage [V]	Rise time [ $\mu$ sec]	Vpeak [kV]	dU/dt [kV/ $\mu$ sec]
36	240	0.244	0.608	1.993
136	240	0.568	0.580	0.816
150	240	0.720	0.574	0.637

**FC 202, P30KT2**

Cable length [m]	Mains voltage [V]	Rise time [ $\mu$ sec]	Vpeak [kV]	dU/dt [kV/ $\mu$ sec]
15	240	0.194	0.626	2.581
50	240	0.252	0.574	1.822
150	240	0.488	0.538	0.882

**FC 202, P37KT2**

Cable length [m]	Mains voltage [V]	Rise time [ $\mu$ sec]	Vpeak [kV]	dU/dt [kV/ $\mu$ sec]
30	240	0.300	0.598	1.594
100	240	0.536	0.566	0.844
150	240	0.776	0.546	0.562

**FC 202, P45KT2**

Cable length [m]	Mains voltage [V]	Rise time [ $\mu$ sec]	Vpeak [kV]	dU/dt [kV/ $\mu$ sec]
30	240	0.300	0.598	1.594
100	240	0.536	0.566	0.844
150	240	0.776	0.546	0.562

**FC 202, P1K5T4**

Cable length [m]	Mains voltage [V]	Rise time [ $\mu$ sec]	Vpeak [kV]	dU/dt [kV/ $\mu$ sec]
5	690	0.640	0.690	0.862
50	985	0.470		0.985
150	1045	0.760	1.045	0.947

**FC 202, P4K0T4**

Cable length [m]	Mains voltage [V]	Rise time [ $\mu$ sec]	Vpeak [kV]	dU/dt [kV/ $\mu$ sec]
5	400	0.172	0.890	4.156
50	400	0.310		2.564
150	400	0.370	1.190	1.770

**FC 202, P7K5T4**

Cable length [m]	Mains voltage [V]	Rise time [ $\mu$ sec]	Vpeak [kV]	dU/dt [kV/ $\mu$ sec]
5	500	0.04755	0.739	8.035
50	500	0.207		4.548
150	500	0.6742	1.030	2.828

**FC 202, P11KT4**

Cable length [m]	Mains voltage [V]	Rise time [ $\mu$ sec]	Vpeak [kV]	dU/dt [kV/ $\mu$ sec]
15	480	0.192	1.300	5.416
100	480	0.612	1.300	1.699
150	480	0.512	1.290	2.015

**FC 202, P15KT4**

Cable length [m]	Mains voltage [V]	Rise time [ $\mu$ sec]	Vpeak [kV]	dU/dt [kV/ $\mu$ sec]
36	480	0.396	1.210	2.444
100	480	0.844	1.230	1.165
150	480	0.696	1.160	1.333

**FC 202, P18KT4**

Cable length [m]	Mains voltage [V]	Rise time [ $\mu$ sec]	Vpeak [kV]	dU/dt [kV/ $\mu$ sec]
36	480	0.396	1.210	2.444
100	480	0.844	1.230	1.165
150	480	0.696	1.160	1.333

**FC 202, P22KT4**

Cable length [m]	Mains voltage [V]	Rise time [ $\mu$ sec]	Vpeak [kV]	dU/dt [kV/ $\mu$ sec]
36	480	0.312		2.846
100	480	0.556	1.250	1.798
150	480	0.608	1.230	1.618

**FC 202, P30KT4**

Cable length [m]	Mains voltage [V]	Rise time [ $\mu$ sec]	Vpeak [kV]	dU/dt [kV/ $\mu$ sec]
15	480	0.288		3.083
100	480	0.492	1.230	2.000
150	480	0.468	1.190	2.034

**FC 202, P37KT4**

Cable length [m]	Mains voltage [V]	Rise time [ $\mu$ sec]	Vpeak [kV]	dU/dt [kV/ $\mu$ sec]
5	480	0.368	1.270	2.853
50	480	0.536	1.260	1.978
100	480	0.680	1.240	1.426
150	480	0.712	1.200	1.334

**FC 202, P45KT4**

Cable length [m]	Mains voltage [V]	Rise time [ $\mu$ sec]	Vpeak [kV]	dU/dt [kV/ $\mu$ sec]
5	480	0.368	1.270	2.853
50	480	0.536	1.260	1.978
100	480	0.680	1.240	1.426
150	480	0.712	1.200	1.334

**FC 202, P55KT4**

Cable length [m]	Mains voltage [V]	Rise time [ $\mu$ sec]	Vpeak [kV]	dU/dt [kV/ $\mu$ sec]
15	480	0.256	1.230	3.847
50	480	0.328	1.200	2.957
100	480	0.456	1.200	2.127
150	480	0.960	1.150	1.052

**FC 202, P75KT4**

Cable length [m]	Mains voltage [V]	Rise time [ $\mu$ sec]	Vpeak [kV]	dU/dt [kV/ $\mu$ sec]
5	480	0.371	1.170	2.523

**FC 202, P90KT4**

Cable length [m]	Mains voltage [V]	Rise time [ $\mu$ sec]	Vpeak [kV]	dU/dt [kV/ $\mu$ sec]
5	480	0.371	1.170	2.523

**High Power Range:****FC 202, P110 - P250, T4**

Cable length [m]	Mains voltage [V]	Rise time [ $\mu$ sec]	Vpeak [kV]	dU/dt [kV/ $\mu$ sec]
30	400	0.34	1.040	2.447

**FC 202, P315 - P1M0, T4**

Cable length [m]	Mains voltage [V]	Rise time [ $\mu$ sec]	Vpeak [kV]	dU/dt [kV/ $\mu$ sec]
30	500	0.71	1.165	1.389
30	400	0.61	0.942	1.233

**FC 202, P110 - P400, T7**

Cable length [m]	Mains voltage [V]	Rise time [ $\mu$ sec]	Vpeak [kV]	dU/dt [kV/ $\mu$ sec]
30	690	0.38	1.513	3.304
30	575	0.23	1.313	2.750
30	690 <sup>1)</sup>	1.72	1.329	0.640

1) With Danfoss dU/dt filter.



<b>FC 202, P450 - P1M2, T7</b>				
Cable length [m]	Mains voltage [V]	Rise time [ $\mu$ sec]	Vpeak [kV]	dU/dt [kV/ $\mu$ sec]
30	690	0.57	1.611	2.261
30	575	0.25		2.510
30	690 <sup>1)</sup>	1.13	1.629	1.150
1) With Danfoss dU/dt filter.				

## 10.5 Special Conditions

### 10.5.1 Purpose of derating

Derating must be taken into account when using the frequency converter at low air pressure (heights), at low speeds, with long motor cables, cables with a large cross section or at high ambient temperature. The required action is described in this section.

### 10.5.2 Derating for Ambient Temperature

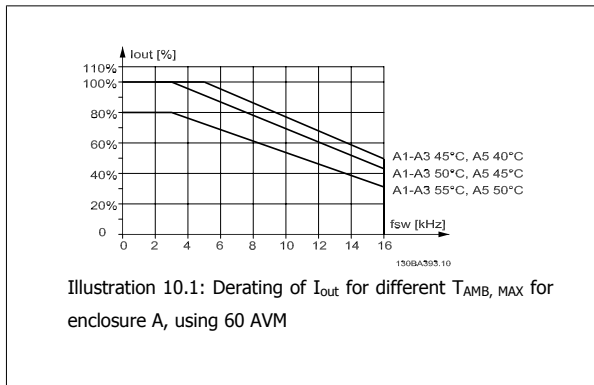
The average temperature ( $T_{AMB,AVG}$ ) measured over 24 hours must be at least 5 °C lower than the maximum allowed ambient temperature ( $T_{AMB,MAX}$ ).

If the frequency converter is operated at high ambient temperatures, the continuous output current should be decreased.

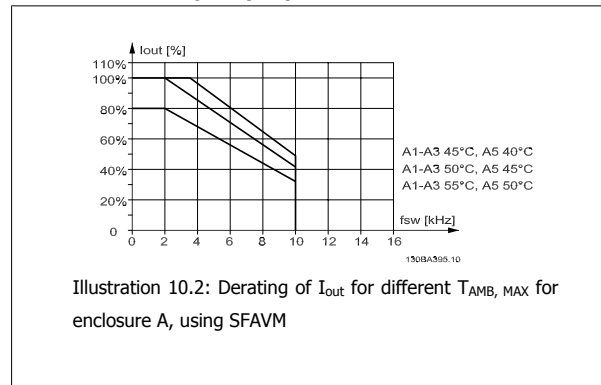
The derating depends on the switching pattern, which can be set to 60 AVM or SFAVM in parameter 14-00.

#### A enclosures

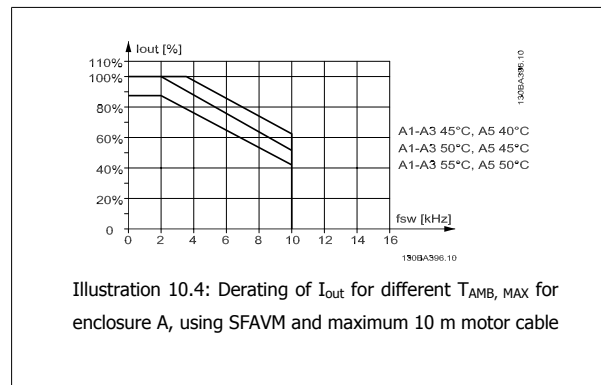
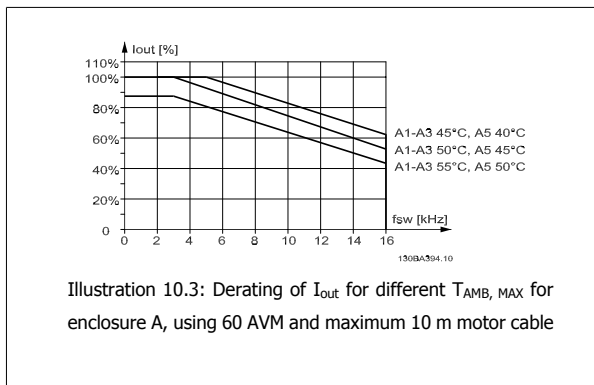
##### 60 AVM - Pulse Width Modulation



##### SFAVM - Stator Frequency Asyncon Vector Modulation

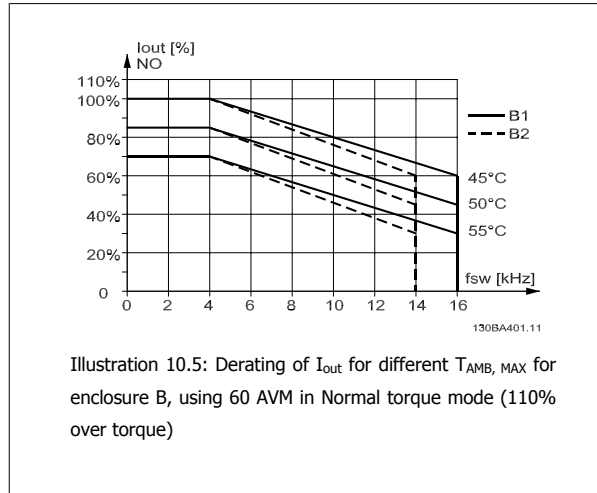


In enclosure A, the length of the motor cable has a relatively high impact on the recommended derating. Therefore, the recommended derating for an application with max. 10 m motor cable is also shown.

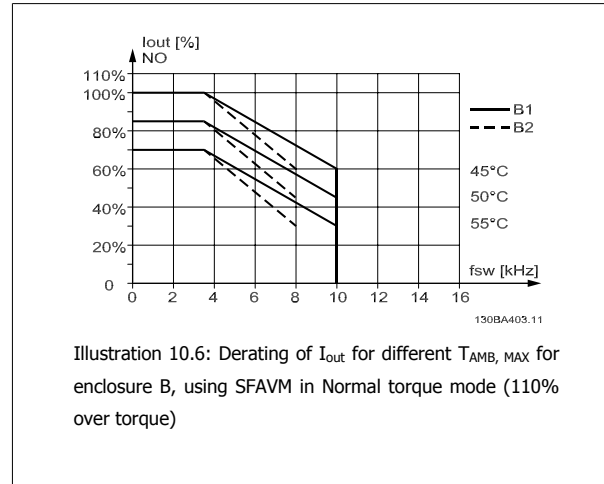


**B enclosures**

**60 AVM - Pulse Width Modulation**



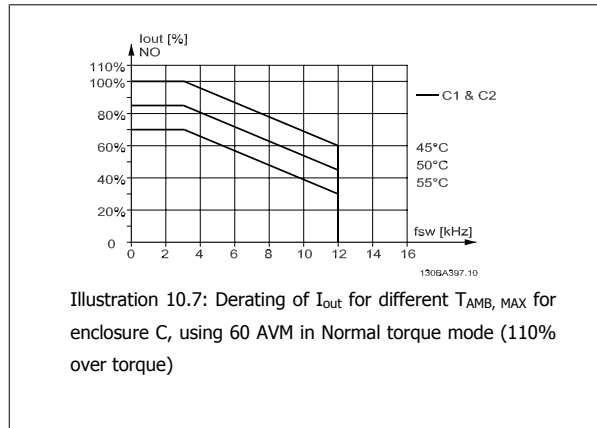
**SFAVM - Stator Frequency Asyncon Vector Modulation**



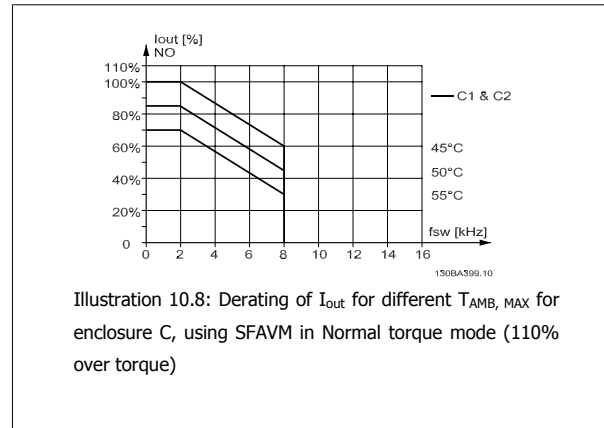
**C enclosures**

Please note: For 90 kW in IP55 and IP66 the max. ambient temperature is 5° C lower.

**60 AVM - Pulse Width Modulation**



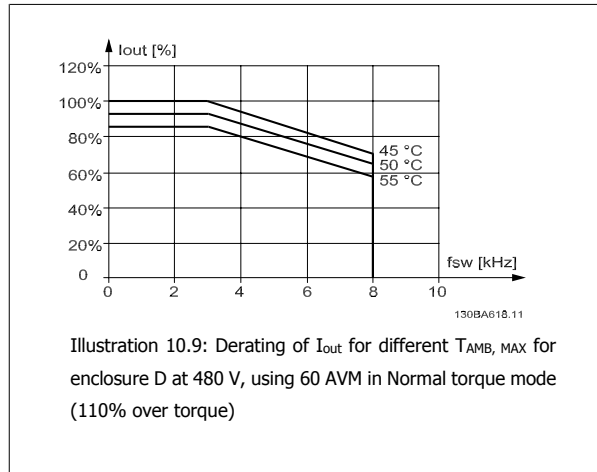
**SFAVM - Stator Frequency Asyncon Vector Modulation**



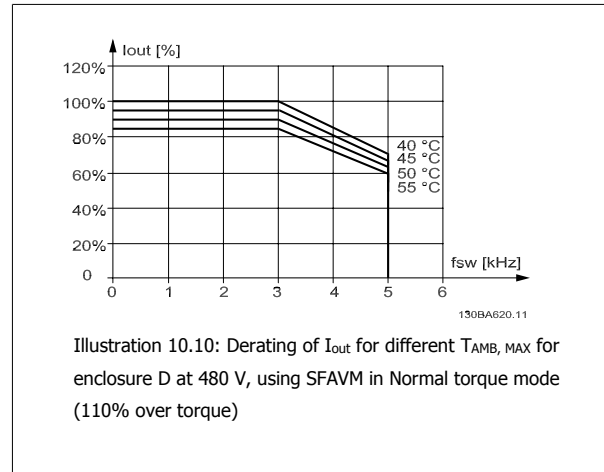
**10**

**D enclosures**

**60 AVM - Pulse Width Modulation, 380 - 480 V**



**SFAVM - Stator Frequency Asyncon Vector Modulation**



**60 AVM - Pulse Width Modulation, 525 - 690 V (except P400)**

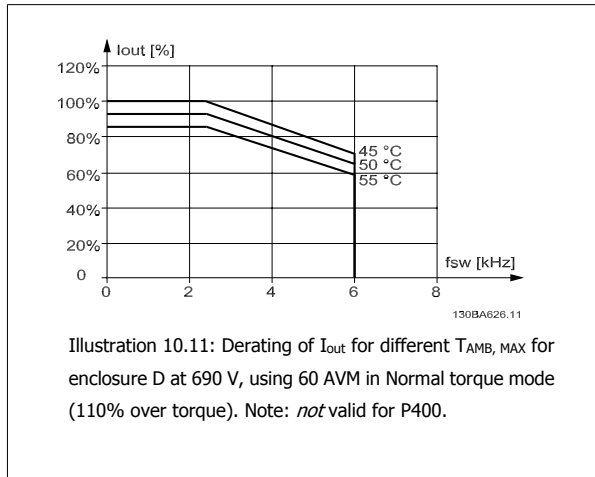


Illustration 10.11: Derating of  $I_{out}$  for different  $T_{AMB, MAX}$  for enclosure D at 690 V, using 60 AVM in Normal torque mode (110% over torque). Note: *not* valid for P400.

**SFAVM - Stator Frequency Asyncon Vector Modulation**

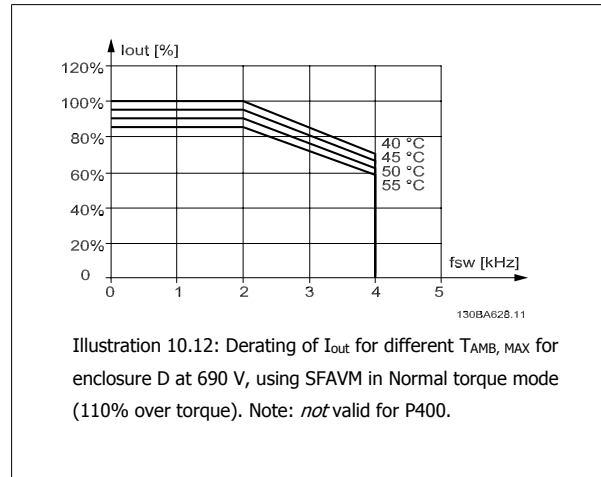


Illustration 10.12: Derating of  $I_{out}$  for different  $T_{AMB, MAX}$  for enclosure D at 690 V, using SFAVM in Normal torque mode (110% over torque). Note: *not* valid for P400.

**60 AVM - Pulse Width Modulation, 525 - 690 V, P400**

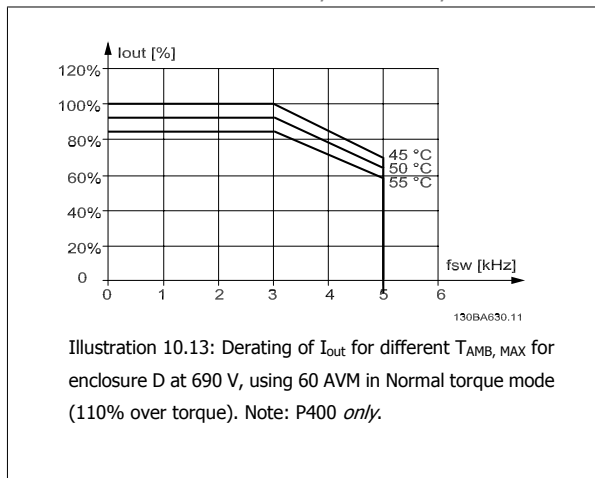


Illustration 10.13: Derating of  $I_{out}$  for different  $T_{AMB, MAX}$  for enclosure D at 690 V, using 60 AVM in Normal torque mode (110% over torque). Note: P400 *only*.

**SFAVM - Stator Frequency Asyncon Vector Modulation**

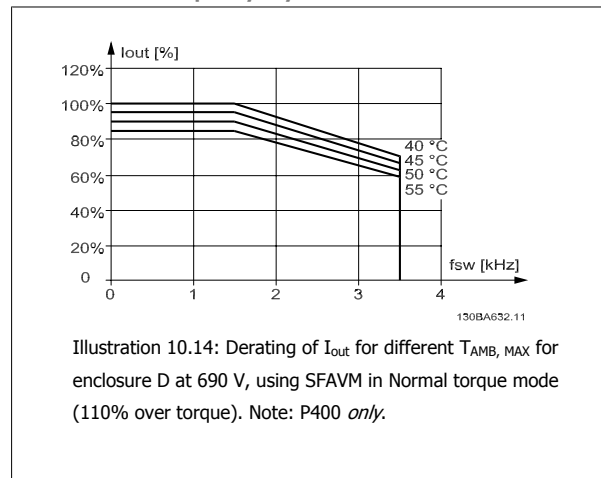


Illustration 10.14: Derating of  $I_{out}$  for different  $T_{AMB, MAX}$  for enclosure D at 690 V, using SFAVM in Normal torque mode (110% over torque). Note: P400 *only*.

10

**E and F enclosures**

**60 AVM - Pulse Width Modulation, 380 - 480 V**

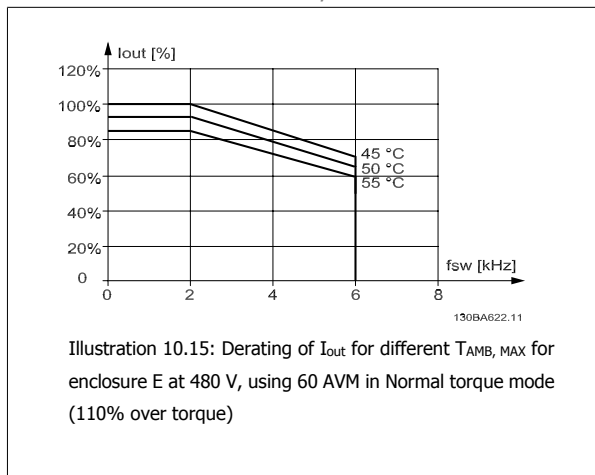


Illustration 10.15: Derating of  $I_{out}$  for different  $T_{AMB, MAX}$  for enclosure E at 480 V, using 60 AVM in Normal torque mode (110% over torque)

**SFAVM - Stator Frequency Asyncon Vector Modulation**

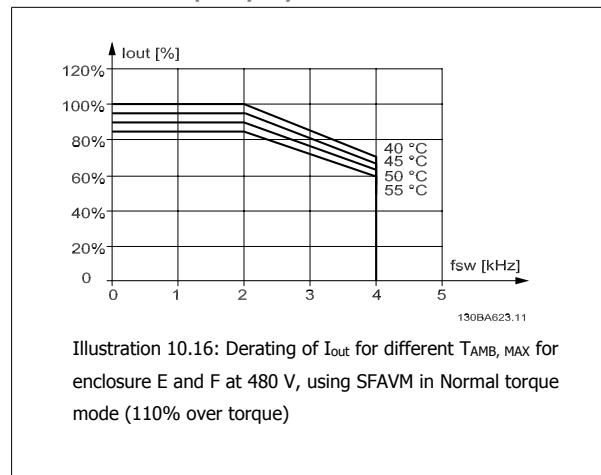
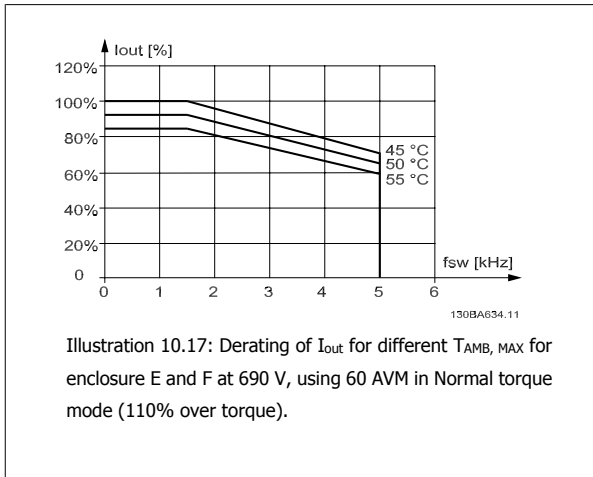
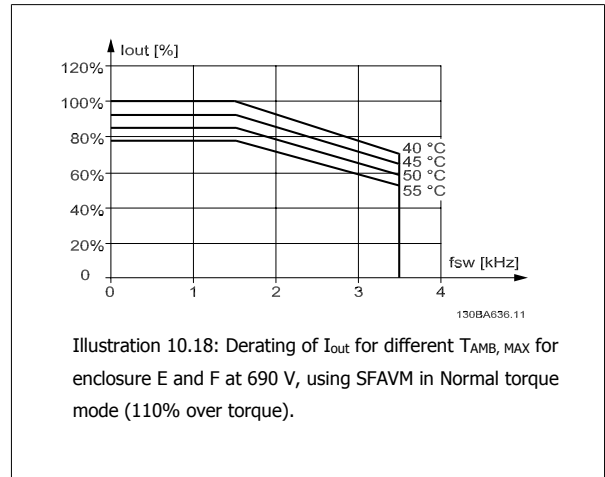


Illustration 10.16: Derating of  $I_{out}$  for different  $T_{AMB, MAX}$  for enclosure E and F at 480 V, using SFAVM in Normal torque mode (110% over torque)

**60 AVM - Pulse Width Modulation, 525 - 690 V**



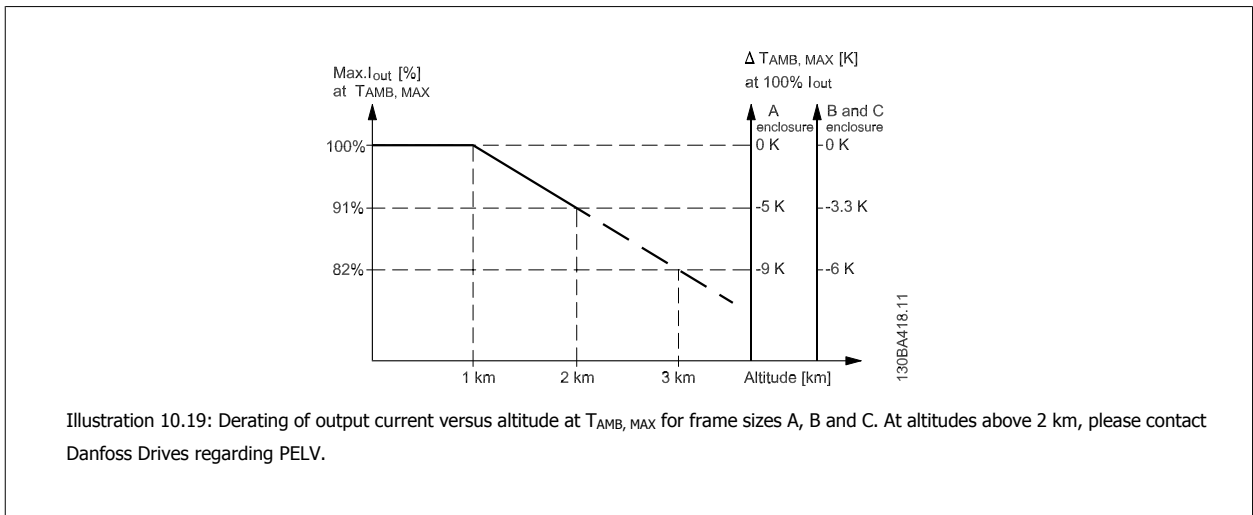
**SFAVM - Stator Frequency Asyncon Vector Modulation**



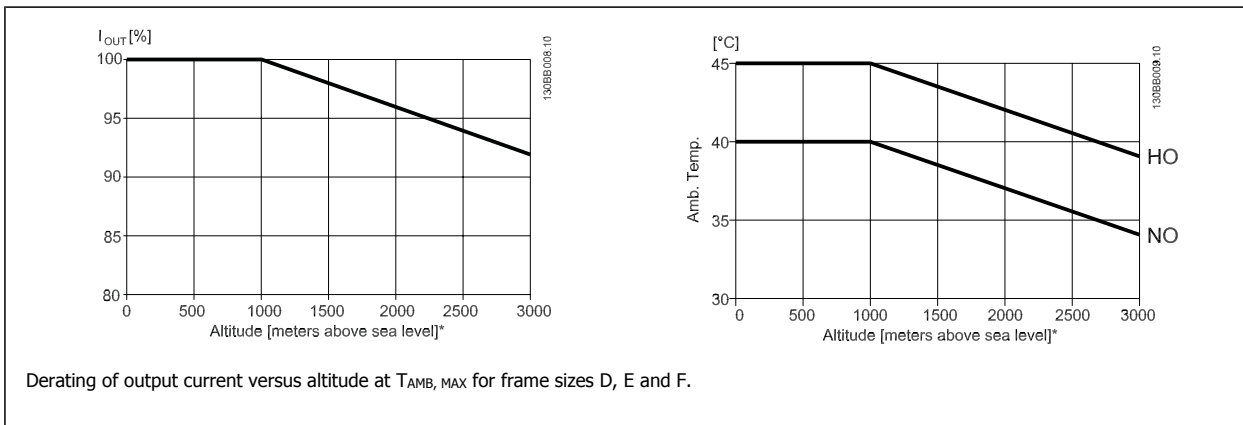
**10.5.3 Derating for Low Air Pressure**

The cooling capability of air is decreased at lower air pressure.

Below 1000 m altitude no derating is necessary but above 1000 m the ambient temperature ( $T_{AMB}$ ) or max. output current ( $I_{out}$ ) should be derated in accordance with the shown diagram.



An alternative is to lower the ambient temperature at high altitudes and thereby ensure 100% output current at high altitudes. As an example of how to read the graph, the situation at 2 km is elaborated. At a temperature of 45° C ( $T_{AMB, MAX} - 3.3$  K), 91% of the rated output current is available. At a temperature of 41.7° C, 100% of the rated output current is available.



### 10.5.4 Derating for Running at Low Speed

When a motor is connected to a frequency converter, it is necessary to check that the cooling of the motor is adequate. The level of heating depends on the load on the motor, as well as the operating speed and time.

#### Constant torque applications (CT mode)

A problem may occur at low RPM values in constant torque applications. In a constant torque application a motor may over-heat at low speeds due to less cooling air from the motor integral fan.

Therefore, if the motor is to be run continuously at an RPM value lower than half of the rated value, the motor must be supplied with additional air-cooling (or a motor designed for this type of operation may be used).

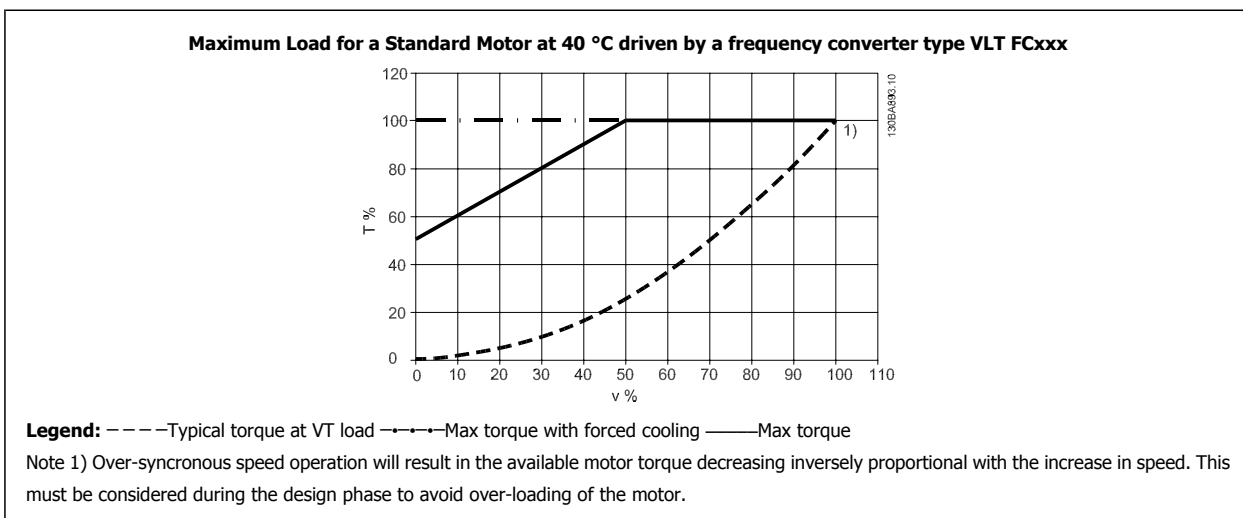
An alternative is to reduce the load level of the motor by choosing a larger motor. However, the design of the frequency converter puts a limit to the motor size.

10

#### Variable (Quadratic) torque applications (VT)

In VT applications such as centrifugal pumps and fans, where the torque is proportional to the square of the speed and the power is proportional to the cube of the speed, there is no need for additional cooling or de-rating of the motor.

In the graphs shown below, the typical VT curve is below the maximum torque with de-rating and maximum torque with forced cooling at all speeds.



### 10.5.5 Derating for Installing Long Motor Cables or Cables with Larger Cross-Section

**NB!**

Applicable for drives up to 90 kW only.

The maximum cable length for this frequency converter is 300 m unscreened and 150 m screened cable.

The frequency converter has been designed to work using a motor cable with a rated cross-section. If a cable with a larger cross-section is used, reduce the output current by 5% for every step the cross-section is increased.

(Increased cable cross-section leads to increased capacity to earth, and thus an increased earth leakage current).

### 10.5.6 Automatic Adaptations to Ensure Performance

The frequency converter constantly checks for critical levels of internal temperature, load current, high voltage on the intermediate circuit and low motor speeds. As a response to a critical level, the frequency converter can adjust the switching frequency and / or change the switching pattern in order to ensure the performance of the frequency converter. The capability to automatically reduce the output current extends the acceptable operating conditions even further.

## Index

### 6

60 Avm	170
--------	-----

### A

Abbreviations And Standards	12
Acceleration Time	82
Access To Control Terminals	42
Acoustic Noise	164
Alarm/warning Code List	144
Alarms And Warnings	143
Ama	52, 62
Analog I/o Option Mcb 109	138
Analog In/out	119
Analog Inputs	161
Analog Output	161
Application Functions	133
Automatic Adaptations To Ensure Performance	175
Automatic Motor Adaptation (ama)	50, 80
Available Literature For Vlt® Aqua Drive	4
Awg	151

### B

Brake Connection Option	37
Brakes	115
Bypass Option	142

### C

Cable Lengths And Cross Sections	160
Cables General	19
Can Fieldbus	122
Can Motor	52
Cascade Controller	136
Cascade Ctl Option	139
Caution	9
Changing A Group Of Numeric Data Values	62
Changing A Text Value	61
Changing Data	61
Changing Of Data Value	62
[Check Valve Ramp End Speed Hz] 3-87	83
[Check Valve Ramp End Speed Rpm] 3-86	82
Check Valve Ramp Time 3-85	82
Checklist	13
Coasting	58
Comm. And Options	120
Communication Option	147
Configuration Mode 1-00	79
Constant Torque Applications (ct Mode)	174
Control Cable Clamp	43
Control Cables	45
Control Cables	44
Control Card Performance	163
Control Card, 10 V Dc Output	162
Control Card, 24 V Dc Output	162
Control Card, Rs-485 Serial Communication:	160
Control Card, Usb Serial Communication	163
Control Characteristics	162
Control Terminals	43
Cooling	174
Cooling Conditions	16
Copyright, Limitation Of Liability And Revision Rights	4



## D

Data Readouts	127
Data Readouts 2	129
Dc Bus Connection	36
Dc Link	146
Default Settings	110
Default Settings	63
Derating For Ambient Temperature	170
Derating For Installing Long Motor Cables Or Cables With Larger Cross-section	175
Derating For Low Air Pressure	173
Derating For Running At Low Speed	174
Digital In/out	118
Digital Inputs:	161
Digital Output	162
Display Line 1.1 Small, 0-20	74
Display Line 1.2 Small, 0-21	77
Display Line 1.3 Small, 0-22	77
Display Line 2 Large, 0-23	77
Display Line 3 Large, 0-24	77
Display Text 1 0-37	77
Display Text 2 0-38	77
Display Text 3 0-39	78
Disposal Instruction	10
Drive Closed Loop, 20-**	95
Dry Pump Delay 22-27	99
Dry Pump Function 22-26	99
Dst/summertime 0-74	78
Dst/summertime End 0-77	78
Dst/summertime Start 0-76	78

## E

Earthing And It Mains	23
Efficiency	164
Efficient Parameter Set-up For Water Applications	67
Electrical Installation	44
Electrical Wiring	52
Electronic Waste	10
Enclosure Knock-outs	19
End Of Curve Delay 22-51	101
End Of Curve Function 22-50	101
Etr	146
Ext. Closed Loop	131

## F

Fault Messages	146
Fc Closed Loop	130
Fc Information	125
Filled Setpoint, 29-05	108
Final Ramp Time 3-88	83
Flow At Rated Speed 22-90	104
Flow Compensation 22-80	102
Frequency Converter	48
Function Relay, 5-40	88
Fuses	21

## G

General Settings, 1-0*	78
General Warning	5
Glcp	63
Graphical Display	55

## H

[High Speed Hz] 22-37	100
-----------------------	-----

[High Speed Power Hp] 22-39	100
[High Speed Power Kw] 22-38	100
[High Speed Rpm] 22-36	100
How To Connect A Pc To The Frequency Converter	64
How To Connect Motor - Foreword	30
How To Connect To Mains And Earthing For B1 And B2	29
How To Operate Graphical Lcp (glcp)	55

## I

Indexed Parameters	62
Indicator Lights (leds):	57
Initial Ramp Time, 3-84	82
Initialisation	63
Installation At High Altitudes	7
Intermediate Circuit	146, 164, 165

## K

Kty Sensor	146
------------	-----

## L

Language - Parameter, 0-01	74
Language Package 1	74
Language Package 2	74
Language Package 3	74
Language Package 4	74
Lcp	62
Lcp 102	55
Leakage Current	8
Leds	55
Limits / Warnings	117
Live Zero Timeout Function 6-01	91
Live Zero Timeout Time 6-00	91
Load/motor	113
Low Power Auto Set-up 22-20	98
Low Power Detection 22-21	98
Low Speed Detection 22-22	98
[Low Speed Hz] 22-33	99
[Low Speed Power Hp] 22-35	100
[Low Speed Power Kw] 22-34	99
[Low Speed Rpm] 22-32	99

## M

Main Menu	67
Main Menu Mode	57
Main Menu Mode	72
Main Reactance	80
Mains Connection For A2 And A3	26
Mains Connection For B1, B2 And B3	29
Mains Connection For B4, C1 And C2	30
Mains Connection For C3 And C4	30
Mains Supply	151, 157, 158
Mains Supply (I1, L2, L3)	160
Mains Supply 1 X 200 - 240 Vac	150
Mains Wiring Overview	25
Maximum Boost Time 22-46	101
Maximum Reference 3-03	81
Mct 10	65
Mechanical Dimensions	15
Mechanical Mounting	16
Minimum Reference 3-02	81
Minimum Run Time 22-40	100
Minimum Sleep Time 22-41	100
Motor Connection For C3 And C4	36
Motor Current 1-24	79
Motor Frequency 1-23	79

Motor Name Plate	48
Motor Nominal Speed 1-25	80
Motor Output	160
[Motor Power Kw] 1-20	79
Motor Protection	160
[Motor Speed High Limit Rpm] 4-13	84
[Motor Speed Low Limit Rpm] 4-11	83
Motor Voltage	165
Motor Voltage 1-22	79
Motor Wiring Overview	32

## N

Name Plate Data	49
Name Plate Data	48
Nlcp	59
No-flow Delay 22-24	99
No-flow Function 22-23	98
No-flow Power 22-30	99
Non UI Compliance	21

## O

Occurrence 23-04	108
Off Action 23-03	107
Off Time 23-02	106
On Action 23-01	105
On Time 23-00	105
Operation/display	111
Output Performance (u, V, W)	160
Over-current Protection	21

## P

Panel Through Mounting	17
Parameter Options	110
Parameter Selection	72
Parameter Set-up	67
Pc Software Tools	65
Peak Voltage On Motor	165
Pid Integral Time 20-94	97
Pid Normal/inverse Control, 20-81	96
Pid Proportional Gain 20-93	97
[Pid Start Speed Rpm] 20-82	97
Pipe Fill Enable, 29-00	108
Pipe Fill Rate, 29-04	108
[Pipe Fill Speed Hz], 29-02	108
[Pipe Fill Speed Rpm], 29-01	108
Pipe Fill Time, 29-03	108
Power Correction Factor 22-31	99
Preset Reference 3-10	81
Pressure At No-flow Speed 22-87	104
Pressure At Rated Speed 22-88	104
Profibus	121
Profibus Dp-v1	65
Protection	21
Protection And Features	160
Pulse Inputs	162
Pulse Width Modulation	170

## Q

Q1 My Personal Menu	68
Q2 Quick Setup	68
Q3 Function Setups	69
Q5 Changes Made	70
Q6 Loggings	71
Quick Menu	57, 67
Quick Menu Mode	57

Quick Transfer Of Parameter Settings When Using Glcp	63
--	----

## R

Ramp 1 Ramp Down Time 3-42	82
Ramp 1 Ramp Up Time 3-41	82
Reference / Ramps	116
Reference/feedback Unit, 20-12	95
Relay Connection	38
Relay Output	41
Relay Outputs	162
Reset	59
Residual Current Device	8
Rise Time	165
Rs-485 Bus Connection	64

## S

Safety Note	7
Safety Requirements Of Mechanical Installation	16
Screened/armoured.	45
Serial Communication	163
Set Date And Time, 0-70	78
Setpoint 1 20-21	96
Setpoint Boost 22-45	101
Sfavn	170
Side-by-side Installation	16
Sine-wave Filter	31
Sine-wave Filter	52
Smart Logic	123
Software Version	3
Special Functions	124
[Speed At Design Point Hz] 22-86	104
[Speed At Design Point Rpm] 22-85	104
[Speed At No-flow Hz] 22-84	104
[Speed At No-flow Rpm] 22-83	104
Square-linear Curve Approximation 22-81	102
Start/stop	51
Stator Frequency Asyncon Vector Modulation	170
Stator Leakage Reactance	80
Status	57
Status Messages	55
Step-by-step	62
Submersible Pump	52
Surroundings	163
Switches S201, S202, And S801	48

## T

Term. 29 High Ref./feedb. Value 5-53	90
Terminal 27 Mode 5-01	84
Terminal 32 Digital Input 5-14	87
Terminal 42 Output 6-50	92
Terminal 42 Output Max Scale 6-52	94
Terminal 42 Output Min Scale 6-51	93
Terminal 53 High Ref./feedb. Value 6-15	92
Terminal 53 High Voltage 6-11	92
Terminal 53 Low Ref./feedb. Value 6-14	92
Terminal 53 Low Voltage 6-10	92
Terminal 54 High Ref./feedb. Value 6-25	92
Terminal 54 High Voltage 6-21	92
Terminal 54 Low Ref./feedb. Value 6-24	92
Terminal 54 Low Voltage 6-20	92
Tightening Of Terminals	19
Time Format 0-72	78
Timed Actions	105, 135
Torque Characteristics	160
Type Code String	11
Type Code String (t/c)	12

## U

Unpacking Table	13
Usb Connection.	43

## V

Variable (quadratic) Torque Applications (vt)	174
Voltage Level	161

## W

Wake-up Ref./fb Difference 22-44	101
[Wake-up Speed Hz] 22-43	101
[Wake-up Speed Rpm] 22-42	100
Warning Against Unintended Start	7
Water Application Functions	141
Water Application Functions, 29.**	108
Wiring Example And Testing	42
Work Point Calculation 22-82	103