

## Contents

<b>1 How to Read this Instruction Manual</b>	<b>1-1</b>
Approvals	1-2
Symbols	1-2
Abbreviations	1-3
<b>2 Safety Instructions and General Warning</b>	<b>2-1</b>
High Voltage	2-1
Avoid Unintended Start	2-2
Safe Stop of the FC 300	2-3
Safe Stop Installation - FC 302 only (and FC 301 in frame size A1)	2-4
IT Line Power	2-4
<b>3 How to Install</b>	<b>3-1</b>
Mechanical Installation	3-5
Electrical Installation	3-7
Connection to Line Power and Grounding	3-8
Motor Connection	3-11
Fuses	3-14
Electrical Installation, Control Terminals	3-19
Connection Examples	3-20
Electrical Installation, Control Cables	3-22
Switches S201, S202, and S801	3-24
Additional Connections	3-27
Mechanical Brake Control	3-27
Motor Thermal Protection	3-28
How to Connect a PC to the Adjustable Frequency Drive	3-28
The FC 300 PC software	3-28
<b>4 How to Program</b>	<b>4-1</b>
The Graphical and Numerical LCP	4-1
How to Program on the Graphical LCP	4-1
How to Program on the Numerical Local Control Panel	4-2
Quick Setup	4-4
Basic set-up parameters	4-8
Parameter Lists	4-29
<b>5 General Specifications</b>	<b>5-1</b>

<b>6 Troubleshooting</b>	6-1
Warnings/Alarm Messages	6-1
<b>7 Index</b>	7-1

# 1 How to Read this Instruction Manual

1

**VLT AutomationDrive**  
**Instruction Manual**  
**Software version: 5.0x**

This Instruction Manual can be used for all VLT AutomationDrive adjustable frequency drives with software version 5.0x. The software version number can be seen from par. 15-43 *Software Version*.

## 1.1.1 How to Read this Instruction Manual

VLT AutomationDrive is designed to provide high shaft performance on electrical motors. Please read this manual carefully for proper use. Incorrect handling of the adjustable frequency drive may cause improper operation of the adjustable frequency drive or related equipment, shorten lifetime or cause other problems.

This Instruction Manual will help you get started, install, program, and troubleshoot your VLT AutomationDrive.

The VLT AutomationDrive comes in twoshaft performance levels. FC 301 ranges from scalar (U/f) to VVC+ and handles asynchronous motors only. FC 302 is a high performance adjustable frequency drive for asynchronous as well as permanent motors and handles various kinds of motor control principles such as scalar (U/f), VVC+ and flux vector motor control.

This Instruction Manual covers both the FC 301 and the FC 302. Where information covers both series, we refer to the FC 300. Otherwise, we refer specifically to either the FC 301 or the FC 302.

Chapter 1, **How to Read this Instruction Manual**, introduces the manual and informs you of the approvals, symbols and abbreviations used in this literature.

Chapter 2, **Safety Instructions and General Warnings**, contains instructions on how to handle the FC 300 correctly.

Chapter 3, **How to Install**, guides you through mechanical and technical installation.

Chapter 4, **How to Program**, shows you how to operate and program the FC 300 via the LCP.

Chapter 5, **General Specifications**, contains technical data about FC 300.

Chapter 6, **Troubleshooting**, assists you in solving problems that may occur when using FC 300.

### Available Literature for FC 300

- The VLT AutomationDrive Instruction Manual provides the necessary information for getting the drive up and running.
- The VLT AutomationDrive Design Guide contains all the technical information about the drive design and applications including encoder, resolver and relay options.
- The VLT AutomationDrive Profibus Instruction Manual provides the information required for controlling, monitoring and programming the drive via a Profibus serial communication bus.
- The VLT AutomationDrive DeviceNet Instruction Manual provides the information required for controlling, monitoring and programming the drive via a DeviceNet serial communication bus.
- The VLT AutomationDrive MCT 10 Instruction Manual provides information for installation and use of the software on a PC.
- The VLT AutomationDrive IP21 / Type 1 Instruction provides information for installing the IP21 / Type 1 option.
- The VLT AutomationDrive 24 V DC Backup Instruction provides information for installing the 24 V DC backup option.

Danfoss technical literature is also available online at [www.danfoss.com/drives](http://www.danfoss.com/drives).

1

1.1.2 Approvals



1.1.3 Symbols

Symbols used in this Instruction Manual.

	<b>NOTE!</b> Indicates something to be noted by the reader.
---	--

	Indicates a general warning.
--	------------------------------

	Indicates a high-voltage warning.
---	-----------------------------------

*	Indicates a default setting
---	-----------------------------

### 1.1.4 Abbreviations

Alternating current	AC
American wire gauge	AWG
Ampere/AMP	A
Automatic Motor Adaptation	AMA
Current limit	$I_{LIM}$
Degrees Celsius	°C
Direct current	DC
Drive Dependent	D-TYPE
Electro Magnetic Compatibility	EMC
Electronic Thermal Relay	ETR
Drive	Adjustable frequency drive
Gram	g
Hertz	Hz
Kilohertz	kHz
Local Control Panel	LCP
Meter	m
Millihenry Inductance	mH
Milliampere	mA
Millisecond	ms
Minute	min
Motion Control Tool	MCT
Nanofarad	nF
Newton Meters	Nm
Nominal motor current	$I_{M,N}$
Nominal motor frequency	$f_{M,N}$
Nominal motor power	$P_{M,N}$
Nominal motor voltage	$U_{M,N}$
Parameter	par.
Protective Extra Low Voltage	PELV
Printed Circuit Board	PCB
Rated Inverter Output Current	$I_{INV}$
Revolutions Per Minute	RPM
Regenerative terminals	Regen
Second	s
Synchronous Motor Speed	$n_s$
Torque limit	$T_{LIM}$
Volt	V

### 1.1.5 Disposal Instructions



Equipment containing electrical components may not be disposed of together with domestic waste. It must be separately collected with electrical and electronic waste according to local and currently valid legislation.



## 2 Safety Instructions and General Warning

2

 The DC link capacitors remain charged after power has been disconnected. To avoid electrical shock hazard, disconnect the adjustable frequency drive from line power before carrying out maintenance. When using a PM motor, make sure it is disconnected. Before servicing the adjustable frequency drive, wait the minimum amount of time indicated below:

Voltage	Power	Waiting Time
200–240 V	0.34–5 hp [0.25–3.7 kW]	4 minutes
	7.5–50 hp [5.5–37 kW]	15 minutes
380–500 V	0.5–10 hp [0.37–7.5 kW]	4 minutes
	15–100 hp [11–75 kW]	15 minutes
525–600 V	1–10 hp [0.75–7.5 kW]	4 minutes

### 2.1.1 High Voltage

 The voltage of the adjustable frequency drive is dangerous whenever the adjustable frequency drive is connected to line power. Incorrect installation or operation of the motor or adjustable frequency drive may cause damage to the equipment, serious personal injury or death. The instructions in this manual must therefore be observed, in addition to applicable local and national rules and safety regulations.

 **Installation in high altitudes**  
 380-500 V: At altitudes higher than 10,000 ft [3 km], please contact Danfoss Drives regarding PELV.  
 525-690 V: At altitudes higher than 6,500 ft [2 km], please contact Danfoss Drives regarding PELV.

### 2.1.2 Safety Precautions

 The voltage of the adjustable frequency drive is dangerous whenever connected to line power. Incorrect installation of the motor, adjustable frequency drive or serial communication bus may cause damage to the equipment, serious personal injury or death. Consequently, the instructions in this manual, as well as national and local rules and safety regulations, must be followed.

#### Safety Regulations

1. The line power supply to the adjustable frequency drive must be disconnected whenever repair work is to be carried out. Make sure that the line power supply has been disconnected and that the necessary time has elapsed before removing motor and line power supply plugs.
2. The [OFF] button on the control panel of the adjustable frequency drive does not disconnect the line power supply and consequently it must not be used as a safety switch.
3. The equipment must be properly grounded, the user must be protected against supply voltage and the motor must be protected against overload in accordance with applicable national and local regulations.
4. The ground leakage current exceeds 3.5 mA.
5. Protection against motor overload is not included in the factory setting. If this function is desired, set par.1-90 *Motor Thermal Protection* to data value ETR trip 1 [4] or data value ETR warning 1 [3].
6. Do not remove the plugs for the motor and line power supply while the adjustable frequency drive is connected to line power. Make sure that the line power supply has been disconnected and that the necessary time has elapsed before removing motor and line power plugs.

7. Please note that the adjustable frequency drive has more voltage sources than L1, L2 and L3, when load sharing (linking of DC intermediate circuit) or external 24 V DC are installed. Make sure that all voltage sources have been disconnected and that the necessary time has elapsed before commencing repair work.

## 2

### 2.1.3 General Warning



**Warning:**

Touching the electrical parts may be fatal - even after the equipment has been disconnected from line power.

Also make sure that other voltage inputs have been disconnected, such as load sharing (linkage of DC intermediate circuit), as well as the motor connection for kinetic backup.

Using VLT® AutomationDrive FC 300: wait at least 15 minutes.

Shorter time is allowed only if indicated on the nameplate for the specific unit.



**Leakage Current**

The ground leakage current from the FC 300 exceeds 3.5 mA. To ensure that the ground cable has a good mechanical connection to the ground connection (terminal 95), the cable cross-section must be at least 0.016 in<sup>2</sup> [10 mm<sup>2</sup>] or 2 times rated earth wires terminated separately.

**Residual Current Device**

This product can cause a DC current in the protective conductor. If a residual current device (RCD) is used for extra protection, only an RCD of Type B (time delayed) may be used on the supply side of this product. See also RCD Application Note MN.90.GX.02.

Protective grounding of the FC 300 and the use of RCDs must always follow national and local regulations.



**NOTE!**

For vertical lifting or hoisting applications it is strongly recommended to ensure that the load can be stopped in case of an emergency or a malfunction of a single part such as a contactor, etc.

If the adjustable frequency drive is in alarm mode or in an overvoltage situation, the mechanical brake cuts in.

### 2.1.4 Before Commencing Repair Work

1. Disconnect the adjustable frequency drive from line power.
2. Disconnect DC bus terminals 88 and 89 from load share applications
3. Wait for the discharge of the DC link. See period of time on the warning label.
4. Remove motor cable

### 2.1.5 Avoid Unintended Start

While the FC 300 is connected to line power, the motor can be started/stopped using digital commands, bus commands, references or via the Local Control Panel (LCP).

- Disconnect the FC 300 from line power whenever personal safety considerations make it necessary to avoid an unintended start.
- To avoid an unintended starts, always activate the [OFF] key before changing parameters.
- An electronic fault, temporary overload, a fault in the line supply, or lost motor connection may cause a stopped motor to start. The FC 300 with Safe Stop (i.e., FC 301 in A1 enclosure and FC 302) provides protection against unintended starts if the Safe Stop Terminal 37 is on low voltage level or disconnected.



### 2.1.6 Safe Stop of the FC 300

The FC 302, and also the FC301 in A1 enclosure, can perform the safety function Safe Torque Off (as defined by IEC 61800-5-2) or Stop Category 0 (as defined in EN 60204-1).

FC 301 A1 enclosure: When safe stop is included in the drive, position 18 of Type Code must be either T or U. If position 18 is B or X, Safe Stop Terminal 37 is not included!

Example:

Type Code for FC 301 A1 with Safe Stop: FC-301PK75T4Z20H4TGXXXXXXA0BXCXXXXD0

It is designed and deemed suitable for the requirements of Safety Category 3 in EN 954-1. This function is called safe stop. Prior to integrating and using safe stop in an installation, a thorough risk analysis must be carried out on the installation in order to determine whether the safe stop functionality and safety category are appropriate and sufficient. In order to install and use the Safe Stop function in accordance with the requirements of Safety Category 3 in EN 954-1, the related information and instructions of the FC 300 Design Guide MG.33.BX.YY must be followed! The information and instructions contained in the Instruction Manual are not sufficient for a correct and safe use of the safe stop functionality!

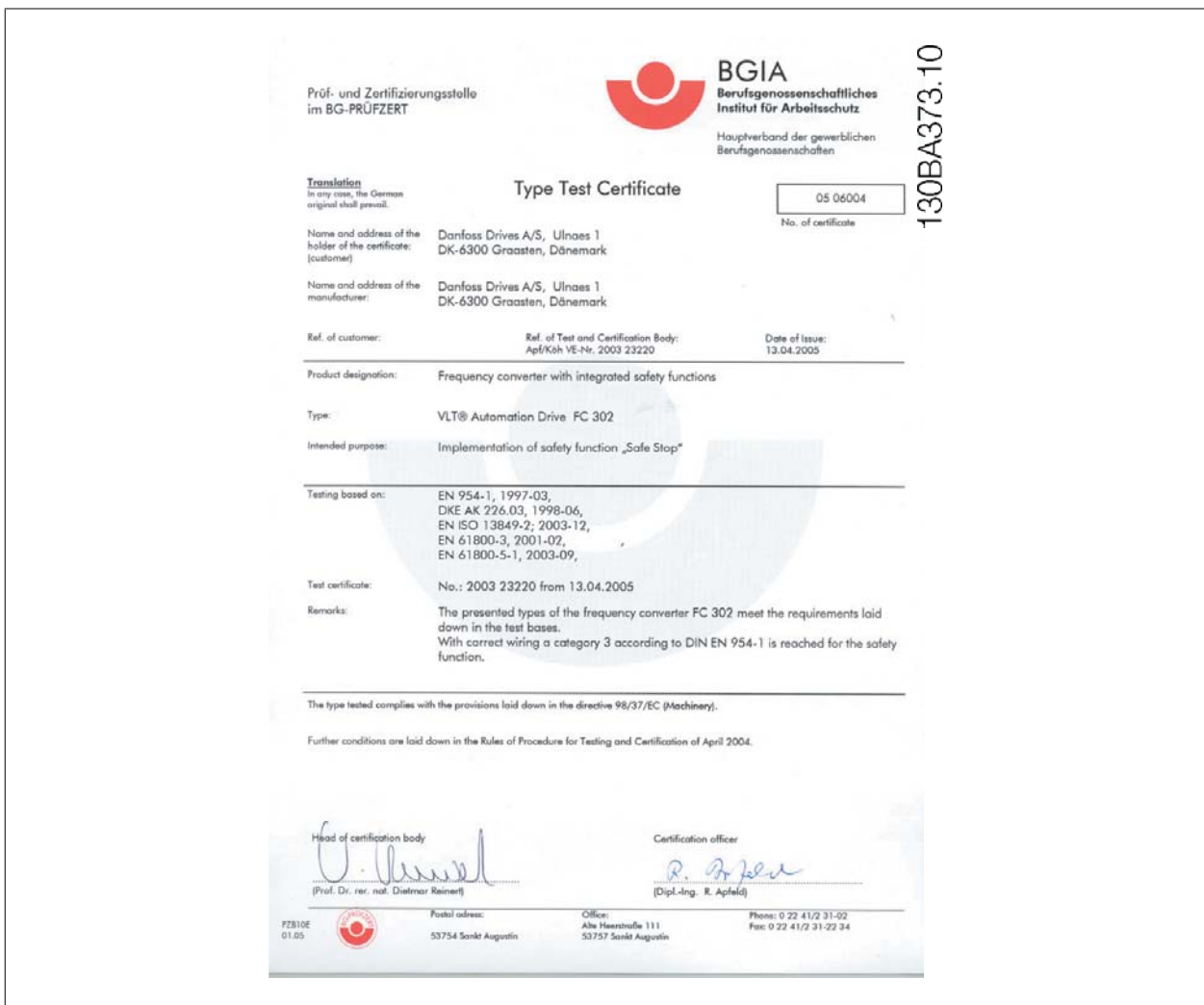

### 2.1.7 Safe Stop Installation - FC 302 only (and FC 301 in frame size A1)

To carry out an installation of a Category 0 Stop (EN60204) in accordance with Safety Category 3 (EN954-1), follow these instructions:

1. The bridge (jumper) between Terminal 37 and 24 V DC must be removed. Cutting or breaking the jumper is not sufficient. Remove it entirely to avoid short-circuiting. See jumper on illustration.
2. Connect terminal 37 to 24 V DC by a short-circuit-protected cable. The 24 V DC voltage supply must be interruptible by an EN954-1 category 3 circuit interrupt device. If the interrupt device and the adjustable frequency drive are placed in the same installation panel, you can use a regular cable instead of a protected one.
3. The Safe Stop function only fulfills EN 954-1 Category 3 if it is protected by an enclosure with protection class IP 54 or higher. Therefore, FC 302s, with a protection class lower than IP54, must be mounted inside a housing (cabinet) that provides IP54 protection. FC 302s with protection class IP54 or higher need no further protection. FC 302 A1 is only delivered with an IP21 enclosure and must therefore always be mounted in a cabinet.

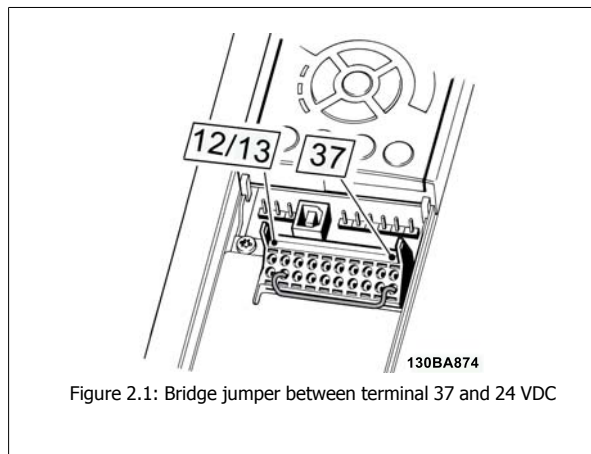

Figure 2.1: Bridge jumper between terminal 37 and 24 VDC

The illustration below shows a Stopping Category 0 (EN 60204-1) with safety Category 3 (EN 954-1). The circuit interruption is caused by an opening door contact. The illustration also shows how to connect a non-safety-related hardware coast.

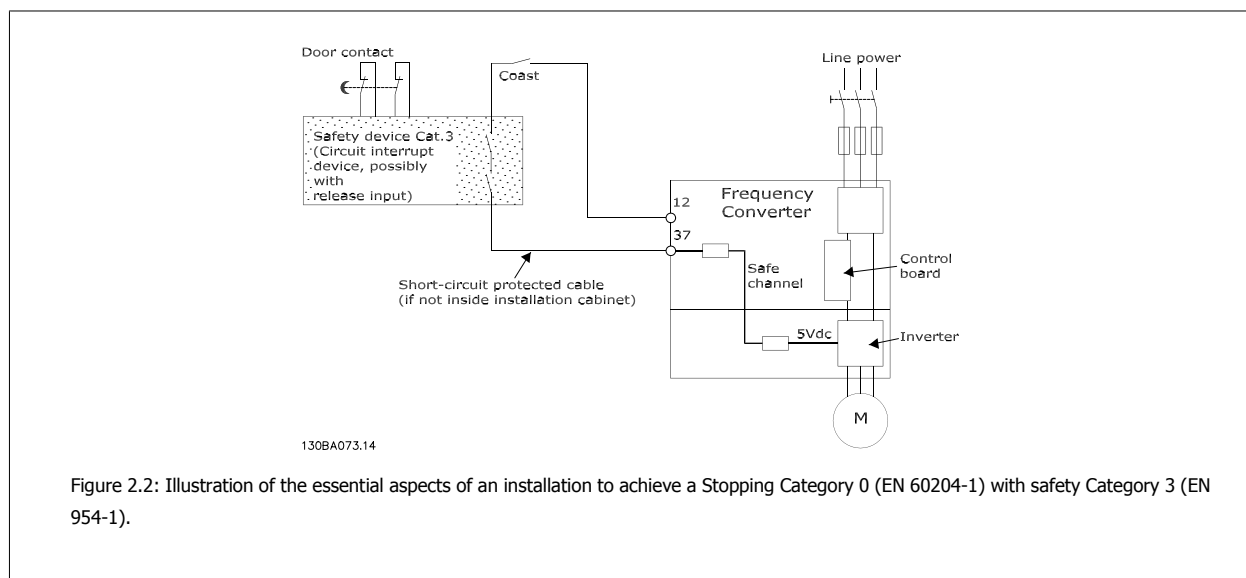

Figure 2.2: Illustration of the essential aspects of an installation to achieve a Stopping Category 0 (EN 60204-1) with safety Category 3 (EN 954-1).

### 2.1.8 IT Line Power

Par. 14-50 *RFI 1* can be used to disconnect the internal RFI capacitors from the RFI filter to ground in the 380-500 V adjustable frequency drives. If this is done, it will reduce the RFI performance to A2 level. For the 525-690 V adjustable frequency drives, par 14-50 has no function. The RFI switch cannot be opened.

# 3 How to Install

## 3.1.1 About How to Install

This chapter covers mechanical and electrical installations to and from power terminals and control card terminals. Electrical installation of *options* is described in the relevant Instruction Manual and Design Guide.

Read the safety instructions before installing the unit.

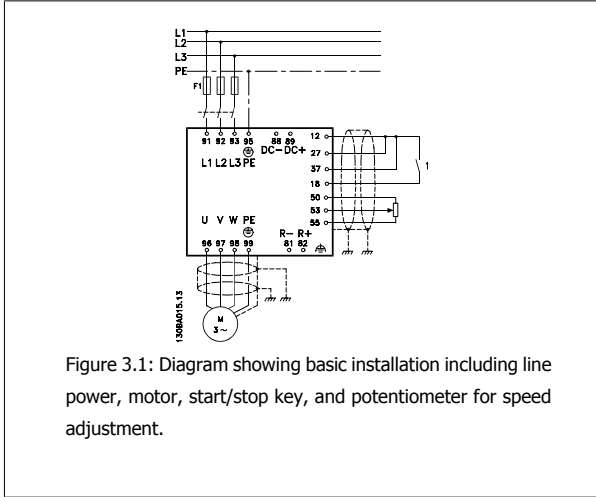

3

## 3.1.2 Checklist

When unpacking the adjustable frequency drive, make sure that the unit is undamaged and complete. Use the following table to identify the packaging:

Frame size:	A1	A2	A3	A5	B1/B3	B2/B4	C1/C3	C2/C4
IP:	20	20/21	20/21	55/66	20/21/5/66	20/21/55/66	20/21/55/66	20/21/55/66

130BA295.10

130BA288.10

For power ratings, please see the *Mechanical Dimensions* table on the next page.

Table 3.1: Unpacking table

Please note that it is recommended to have a selection of screwdrivers (phillips or cross-thread screwdriver and torx), a side-cutter, drill and knife handy for unpacking and mounting the adjustable frequency drive. The packaging for these enclosures contains, as shown: accessory bag(s), documentation and the unit. Depending on options fitted, there may be one or two bags and one or more booklets.

A1	A2	A3	A5	B1	B2	B3	B4	C1	C2	C3	C4
IP20	IP20/21	IP20/21	IP55/66	IP21/55/66	IP21/55/66	IP20	IP20	IP21/55/66	IP21/55/66	IP20	IP20
<p>Accessory bags containing necessary brackets, screws and connectors are included with the drives upon delivery.</p> <p style="text-align: right;">Top and bottom mounting holes (B4, C3 and C4 only)</p>											
<p>All measurements in mm. * A5 in IP55/66 only</p>											

Frame Size	A1	A2	A3	A5	B1	B2	B3	B4	C1	C2	C3	C4
<b>Rated Power</b>	200–240 V 380–480/500 V 525–600 V	0.25–3 0.37–4.0	3.7 5.5–7.5	0.25–3.7 0.37–7.5	5.5–7.5 11–15	11 18.5–22	5.5–7.5 11–15	11–15 18.5–30	15–22 30–45	30–37 55–75	18.5–22 37–45	30–37 55–75
<b>IP</b>	20	21	20	55/66	21/55/66	21/55/66	20	20	55/66	55–90	20	20
<b>NEMA</b>	Chassis	Chassis	Chassis	Type 12	Type 1/Type 12	Type 1/Type 12	Chassis	Chassis	Type 1/Type 12	Type 1/Type 12	Chassis	Chassis
<b>Height</b>												
<b>Height of backplate</b>	A 7.87 in [200 mm]	14.8 in [375 mm]	10.6 in [268 mm]	16.5 in [420 mm]	18.9 in [480 mm]	25.6 in [650 mm]	15.7 in [399 mm]	20.5 in [520 mm]	26.8 in [680 mm]	30.3 in [770 mm]	21.7 in [550 mm]	26 in [660 mm]
<b>Height with de-coupling plate</b>	A 12.4 in [316 mm]	14.7 in [374 mm]	14.7 in [374 mm]	-	-	-	16.5 in [420 mm]	23.4 in [595 mm]	24.8 in [630 mm]	24.8 in [630 mm]	24.8 in [630 mm]	31.5 in [800 mm]
<b>Distance between mounting holes</b>	a 7.5 in [190 mm]	10.1 in [257 mm]	10.1 in [257 mm]	15.8 in [402 mm]	17.9 in [454 mm]	24.6 in [624 mm]	15 in [380 mm]	19.5 in [495 mm]	25.5 in [648 mm]	29.1 in [739 mm]	20.5 in [521 mm]	24.8 in [631 mm]
<b>Width</b>												
<b>Width of backplate</b>	B 3 in [75 mm]	3.5 in [90 mm]	5.1 in [130 mm]	9.5 in [242 mm]	9.5 in [242 mm]	9.5 in [242 mm]	6.5 in [165 mm]	9.1 in [230 mm]	12.1 in [308 mm]	14.6 in [370 mm]	12.1 in [308 mm]	14.6 in [370 mm]
<b>Width of backplate with one C option</b>	B 5.1 in [130 mm]	5.1 in [130 mm]	6.7 in [170 mm]	9.5 in [242 mm]	9.5 in [242 mm]	9.5 in [242 mm]	8.1 in [205 mm]	9.1 in [230 mm]	12.1 in [308 mm]	14.6 in [370 mm]	12.1 in [308 mm]	14.6 in [370 mm]
<b>Width of backplate with two C options</b>	B 5.9 in [150 mm]	5.9 in [150 mm]	7.5 in [190 mm]	9.5 in [242 mm]	9.5 in [242 mm]	9.5 in [242 mm]	8.9 in [225 mm]	9.1 in [230 mm]	12.1 in [308 mm]	14.6 in [370 mm]	12.1 in [308 mm]	14.6 in [370 mm]
<b>Distance between mounting holes</b>	b 2.4 in [60 mm]	2.8 in [70 mm]	4.3 in [110 mm]	8.5 in [215 mm]	8.3 in [210 mm]	8.3 in [210 mm]	5.5 in [140 mm]	7.87 in [200 mm]	10.7 in [272 mm]	13.2 in [334 mm]	10.6 in [270 mm]	13 in [330 mm]
<b>Depth</b>												
<b>Depth without option A/B</b>	C 8.2 in [207 mm]	8.2 in [207 mm]	8.1 in [205 mm]	7.7 in [195 mm]	10.2 in [260 mm]	10.2 in [260 mm]	9.8 in [249 mm]	9.5 in [242 mm]	12.2 in [310 mm]	13.2 in [335 mm]	13.1 in [333 mm]	13.1 in [333 mm]
<b>With option A/B</b>	C 8.7 in [222 mm]	8.7 in [222 mm]	8.7 in [220 mm]	7.7 in [195 mm]	10.2 in [260 mm]	10.2 in [260 mm]	10.3 in [262 mm]	9.5 in [242 mm]	12.2 in [310 mm]	13.2 in [335 mm]	13.1 in [333 mm]	13.1 in [333 mm]
<b>Screw holes</b>												
<b>c</b>	0.24 in [6.0 mm]	0.31 in [8.0 mm]	0.31 in [8.0 mm]	0.32 in [8.25 mm]	0.47 in [12 mm]	0.47 in [12 mm]	0.31 in [8 mm]	0.49 in [12.5 mm]	0.49 in [12.5 mm]	0.49 in [12.5 mm]	0.49 in [12.5 mm]	0.49 in [12.5 mm]
<b>d</b>	ø0.35 in [8 mm]	ø0.43 in [11 mm]	ø0.43 in [11 mm]	ø0.47 in [12 mm]	ø0.75 in [19 mm]	ø0.75 in [19 mm]	0.47 in [12 mm]	0.75 in [19 mm]	ø0.75 in [19 mm]	ø0.75 in [19 mm]	ø0.75 in [19 mm]	ø0.75 in [19 mm]
<b>e</b>	ø0.20 in [5 mm]	ø0.22 in [5.5 mm]	ø0.22 in [5.5 mm]	ø0.26 in [6.5 mm]	ø0.35 in [9 mm]	ø0.35 in [9 mm]	0.27 in [6.8 mm]	0.33 in [8.5 mm]	ø0.35 in [9 mm]	ø0.35 in [9 mm]	0.33 in [8.5 mm]	0.33 in [8.5 mm]
<b>f</b>	0.2 in [5 mm]	0.35 in [9 mm]	0.35 in [9 mm]	0.35 in [9 mm]	0.35 in [9 mm]	0.35 in [9 mm]	0.31 in [7.9 mm]	0.59 in [15 mm]	0.4 in [9.8 mm]	0.4 in [9.8 mm]	0.67 in [17 mm]	0.67 in [17 mm]
<b>Max weight</b>	5.9 lbs [2.7 kg]	10.8 lbs [4.9 kg]	14.6 lbs [6.6 kg]	28.8/31.3 lbs [13.5/14.2 kg]	50.7 lbs [23 kg]	59.5 lbs [27 kg]	26.5 lbs [12 kg]	51.8 lbs [23.5 kg]	99.2 lbs [45 kg]	143.3 lbs [65 kg]	77.1 lbs [35 kg]	110.2 lbs [50 kg]

### 3.2 Mechanical Installation

#### 3.2.1 Mechanical mounting

All IP20 Frame Sizes as well as IP21/ IP55 Frame Sizes except A1\*, A2 and A3 allow side-by-side installation. Open Chassis, Nema 12, and Nema 4 drives can be mounted side-by-side.

If the IP 21 Enclosure kit is used on frame size A1, A2 or A3, there must be 2 in [50 mm] of clearance between the drives of min. 2 in [50 mm].

For optimal cooling conditions, allow a free air passage above and below the adjustable frequency drive. See table below.

**Air passage for different frame sizes**

Frame size:	A1*	A2	A3	A5	B1	B2	B3	B4	C1	C2	C3	C4
a (mm):	100	100	100	100	200	200	200	200	200	225	200	225
b (mm):	100	100	100	100	200	200	200	200	200	225	200	225

Table 3.2: \* FC 301 only!

1. Drill holes in accordance with the measurements given.
2. You must provide screws suitable for the surface on which you want to mount the adjustable frequency drive. Retighten all four screws.

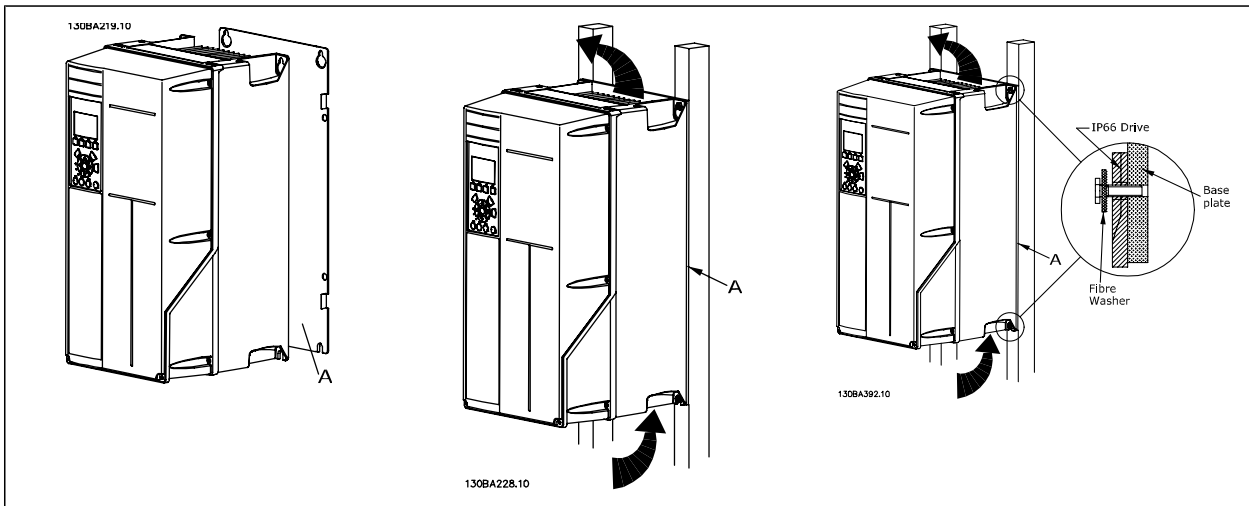

Table 3.3: Mounting frame sizes A5, B1, B2, B3, B4, C1, C2, C3 and C4 on a non-solid back wall, the drive must be provided with a backplate A due to insufficient cooling air over the heatsink.

### 3.2.2 Panel Through Mounting

A Panel Through mount kit is available for adjustable frequency drive series VLT HVAC FC 102, VLT Aqua Drive and VLT AutomationDrive.

In order to increase heatsink cooling and reduce panel depth, the adjustable frequency drive may be mounted in a through panel. Furthermore, the built-in fan can then be removed.

The kit is available for enclosures A5 through C2.



**NOTE!**

This kit cannot be used with cast front covers. No cover or imminent plastic cover must be used instead.

Information on ordering numbers is found in the *Design Guide*, section *Ordering Numbers*.

More detailed information is available in the *Panel Through Mount Kit instruction*, *MI.33.H1.YY*, where yy=language code.



### 3.3 Electrical Installation

**NOTE!**  
**Cables General**  
 All cabling must comply with national and local regulations on cable cross-sections and ambient temperature. Copper (140°–167°F [60°–75°C]) conductors are recommended.

#### Aluminum Conductors

Terminals can accept aluminum conductors, but the conductor surface must be clean, and the oxidation must be removed and sealed by neutral acid-free Vaseline grease before the conductor is connected.

Furthermore, the terminal screw must be retightened after two days due to softness of the aluminum. It is crucial to keep the connection a gas-tight joint, otherwise the aluminum surface will oxidize again.

Tightening Torque					
Frame size	200–240 V	380–500 V	525–690 V	Cable for:	Tightening torque
A1	0.34–2 hp [0.25–1.5 kW]	0.5–2 hp [0.37–1.5 kW]	-	Line power, brake resistor, load sharing, motor cables	0.5–0.6 Nm
A2	0.34–3 hp [0.25–2.2 kW]	0.5–5 hp [0.37–4 kW]	-		
A3	4–5 hp [3–3.7 kW]	7.5–10 hp [5.5–7.5 kW]	7.5–10 hp [0.75–7.5 kW]		
A5	4–5 hp [3–3.7 kW]	7.5–10 hp [5.5–7.5 kW]	1–10 hp [0.75–7.5 kW]		
B1	7.5–10 hp [5.5–7.5 kW]	15–20 hp [11–15 kW]	-	Line power, brake resistor, load sharing, motor cables	1.8 Nm
B2	11 kW	25–30 hp [18.5–22 kW]	-	Relay	0.5–0.6 Nm
				Motor cables	4.5 Nm
				Ground	2–3 Nm
B3	7.5–10 hp [5.5–7.5 kW]	15–20 hp [11–15 kW]	-	Line power, brake resistor, load sharing, motor cables	1.8 Nm
				Relay	0.5–0.6 Nm
				Ground	2–3 Nm
B4	15–20 hp [11–15 kW]	25–40 hp [18.5–30 kW]	-	Line power, brake resistor, load sharing, motor cables	4.5 Nm
				Relay	0.5–0.6 Nm
				Ground	2–3 Nm
C1	20–30 hp [15–22 kW]	40–60 hp [30–45 kW]	-	Line power, brake resistor, load sharing cables	10 Nm
				Motor cables	10 Nm
				Relay	0.5–0.6 Nm
				Ground	2–3 Nm
C2	40–50 hp [30–37 kW]	75–100 hp [55–75 kW]	-	Line power, motor cables	14 Nm (up to 0.15 in <sup>2</sup> [95 mm <sup>2</sup> ]) 24 Nm (over 0.15 in <sup>2</sup> [95 mm <sup>2</sup> ])
				Load sharing, brake cables	14 Nm
				Relay	0.5–0.6 Nm
				Ground	2–3 Nm
C3	25–30 hp [18.5–22 kW]	40–50 hp [30–37 kW]	-	Line power, brake resistor, load sharing, motor cables	10 Nm
				Relay	0.5–0.6 Nm
				Ground	2–3 Nm
C4	50–60 hp [37–45 kW]	75–100 hp [55–75 kW]	-	Line power, motor cables	14 Nm (up to 0.15 in <sup>2</sup> [95 mm <sup>2</sup> ]) 24 Nm (over 0.15 in <sup>2</sup> [95 mm <sup>2</sup> ])
				Load sharing, brake cables	14 Nm
				Relay	0.5–0.6 Nm
				Ground	2–3 Nm

3

### 3.3.1 Removal of Knockouts for Extra Cables

1. Remove the cable entry from the adjustable frequency drive (this prevents foreign parts from falling into the adjustable frequency drive when removing knockouts)
2. The cable entry must be supported around the knockout you intend to remove.
3. The knockout can now be removed with a strong mandrel and a hammer.
4. Remove burrs from the hole.
5. Mount cable entry on adjustable frequency drive.

### 3.3.2 Connection to Line Power and Grounding

**NOTE!**  
The plug connector for power is plugable on adjustable frequency drives up to 10 hp [7.5 kW].

1. Insert the two screws into the de-coupling plate, slide it into place and tighten the screws.
2. Make sure the adjustable frequency drive is properly grounded. Connect to ground connection (terminal 95). Use the screw from the accessory bag.
3. Place plug connector 91 (L1), 92 (L2), 93 (L3) from the accessory bag onto the terminals labeled MAINS at the bottom of the adjustable frequency drive.
4. Attach the line wires to the line power plug connector.
5. Support the cable with the enclosed supporting brackets.

**NOTE!**  
Ensure that AC line voltage corresponds to the AC line voltage on the nameplate.

**IT Line Power**  
Do not connect 400 V adjustable frequency drives with RFI filters to line power supplies with a voltage between phase and ground of more than 440 V.

The ground connection cable cross-section must be at least 0.016 in<sup>2</sup> [10 mm<sup>2</sup>] or 2 x rated line power wires terminated separately according to EN 50178.

The AC line input connections are fitted to the line switch if this is included.

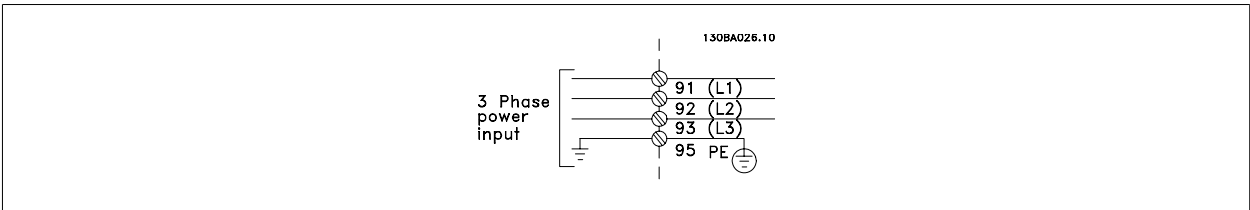

AC line input connections for Frame sizes A1, A2 and A3:

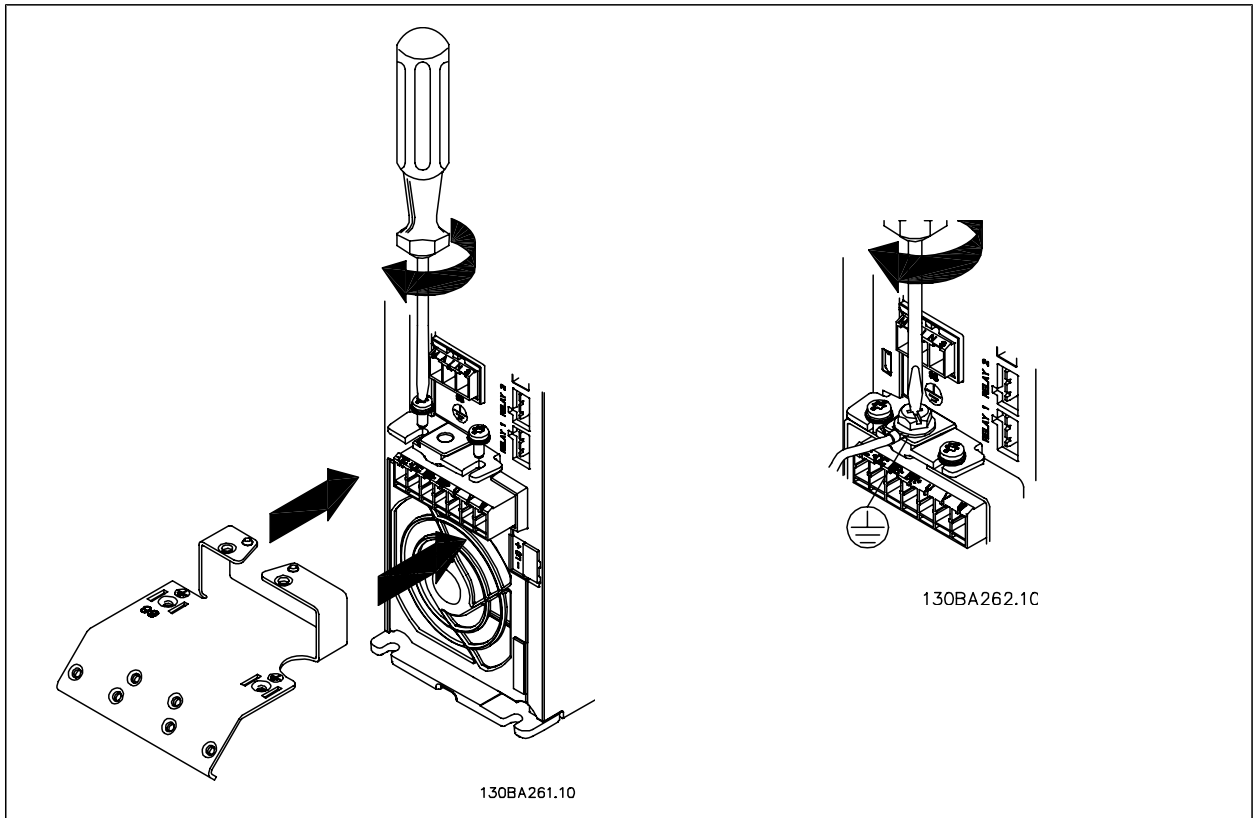

3

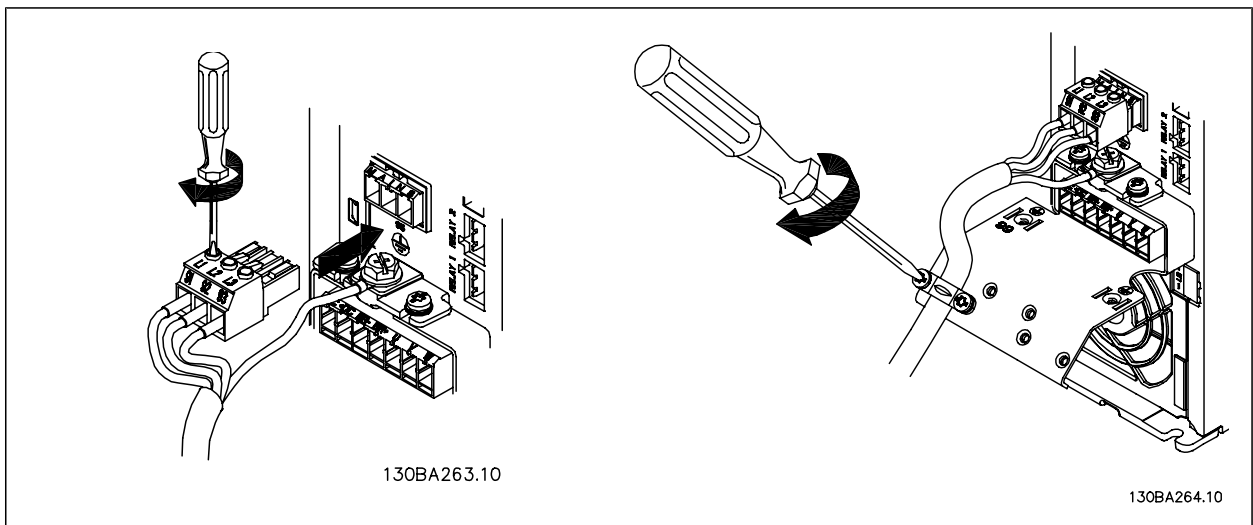

AC line power connector frame size A5 (IP 55/66)

3

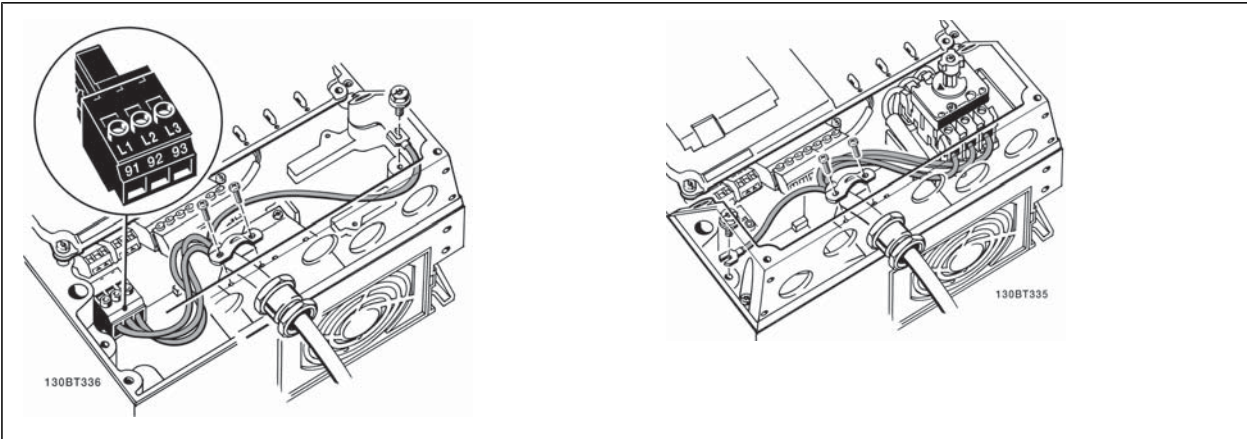

When disconnecter is used (frame size A5), the PE must be mounted on the left side of the drive.

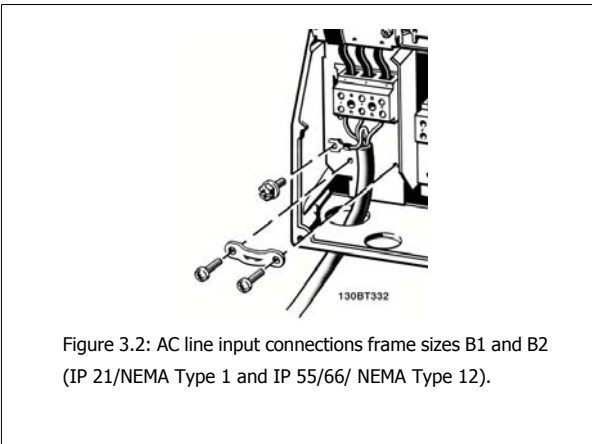

Figure 3.2: AC line input connections frame sizes B1 and B2 (IP 21/NEMA Type 1 and IP 55/66/ NEMA Type 12).

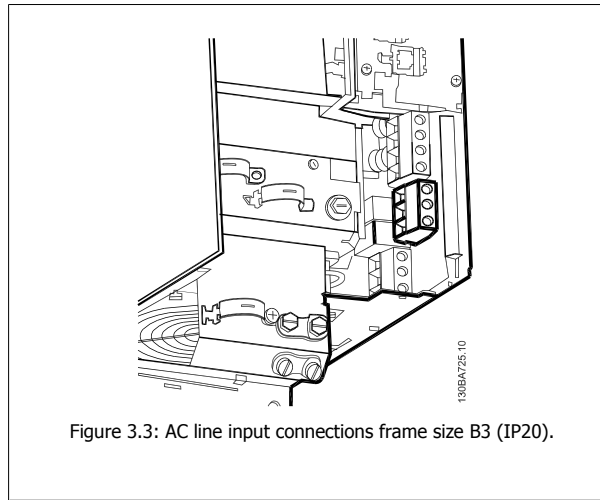

Figure 3.3: AC line input connections frame size B3 (IP20).

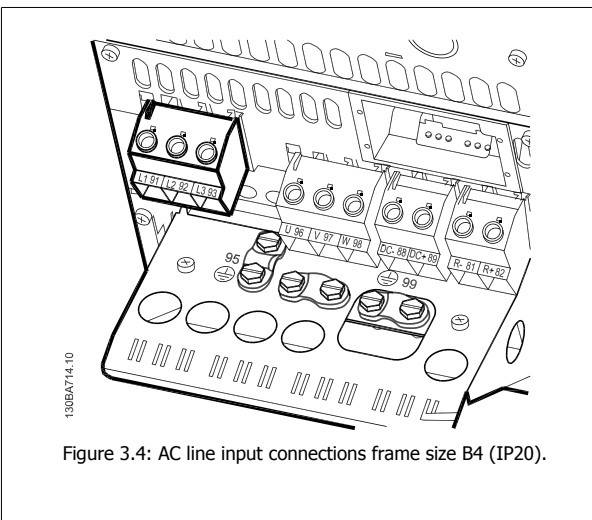

Figure 3.4: AC line input connections frame size B4 (IP20).

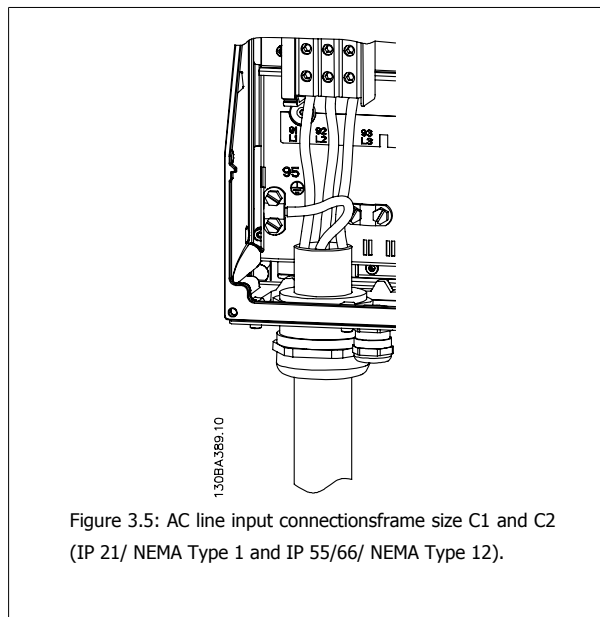

Figure 3.5: AC line input connections frame size C1 and C2 (IP 21/ NEMA Type 1 and IP 55/66/ NEMA Type 12).

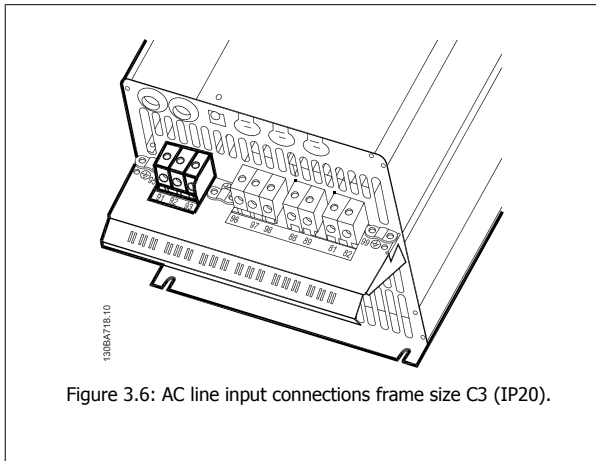

Figure 3.6: AC line input connections frame size C3 (IP20).

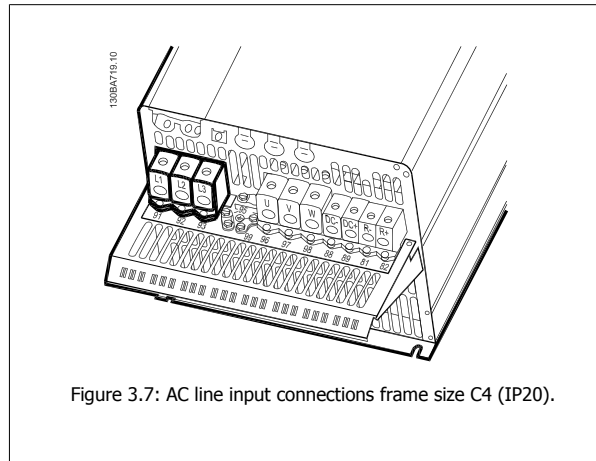

Figure 3.7: AC line input connections frame size C4 (IP20).

The power cables for line power are usually unshielded cables.

### 3.3.3 Motor Connection

**NOTE!**  
 Motor cable must be shielded/armored. The use of a non-shielded/unarmored cable is against EMC requirements. Use a shielded/armored motor cable to comply with EMC emission specifications. For more information, see *EMC Test Results*.

See section General Specifications for correct dimensioning of motor cable cross-section and length.

**Shielding cables:** Avoid installation with twisted shield ends (pigtailed). They spoil the shielding effect at higher frequencies. If it is necessary to break the shield to install a motor isolator or motor contactor, the shield must be continued at the lowest possible HF impedance.

Connect the motor cable shield to both of the decoupling plate on the adjustable frequency drive and to the metal housing on the motor.

Make the shield connections with the largest possible surface area (cable clamp). This is done by using the supplied installation devices in the adjustable frequency drive.

If it is necessary to split the shield to install a motor isolator or motor relay, the shield must be continued with the lowest possible HF impedance.

**Cable-length and cross-section:** The adjustable frequency drive has been tested with a given length of cable and a given cross-section of that cable. If the cross-section is increased, the cable capacitance - and thus the leakage current - may increase, thereby requiring that the cable length is reduced accordingly. Keep the motor cable as short as possible to reduce the noise level and leakage currents.

**Switching frequency:** When adjustable frequency drives are used together with sine-wave filters to reduce the acoustic noise from a motor, the switching frequency must be set according to the sine-wave filter instruction in par. 14-01 *Switching Frequency*.

1. Fasten a decoupling plate to the bottom of the adjustable frequency drive with screws and washers from the accessory bag.
2. Attach motor cable to terminals 96 (U), 97 (V), 98 (W).
3. Connect to ground connection (terminal 99) on decoupling plate with screws from the accessory bag.
4. Insert plug connectors 96 (U), 97 (V), 98 (W) (up to 10 hp [7.5 kW]) and motor cable to terminals labeled MOTOR.
5. Fasten shielded cable to the decoupling plate with screws and washers from the accessory bag.

All types of three-phase asynchronous standard motors can be connected to the adjustable frequency drive. Normally, small motors are star-connected (230/400 V, Y). Large motors are normally delta-connected (400/690 V, Δ). Refer to the motor nameplate for correct connection mode and voltage.

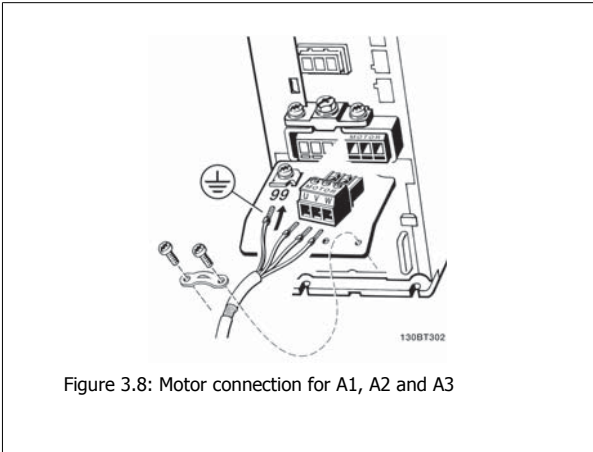

Figure 3.8: Motor connection for A1, A2 and A3

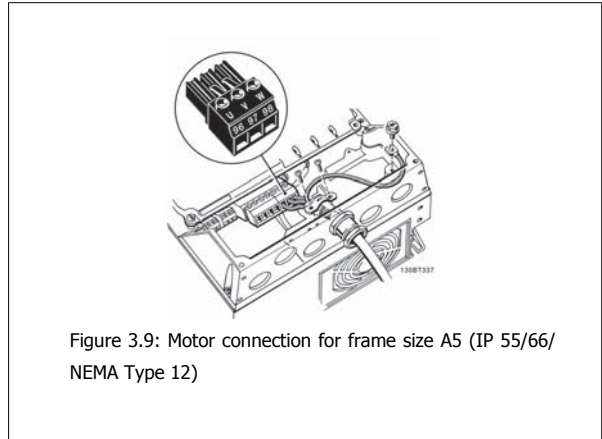

Figure 3.9: Motor connection for frame size A5 (IP 55/66/ NEMA Type 12)

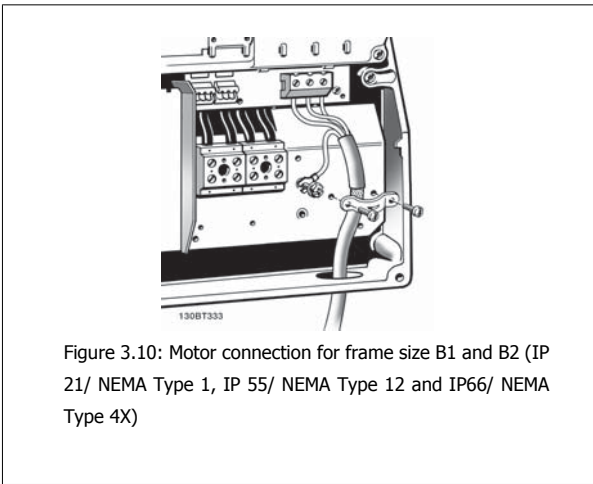

Figure 3.10: Motor connection for frame size B1 and B2 (IP 21/ NEMA Type 1, IP 55/ NEMA Type 12 and IP66/ NEMA Type 4X)

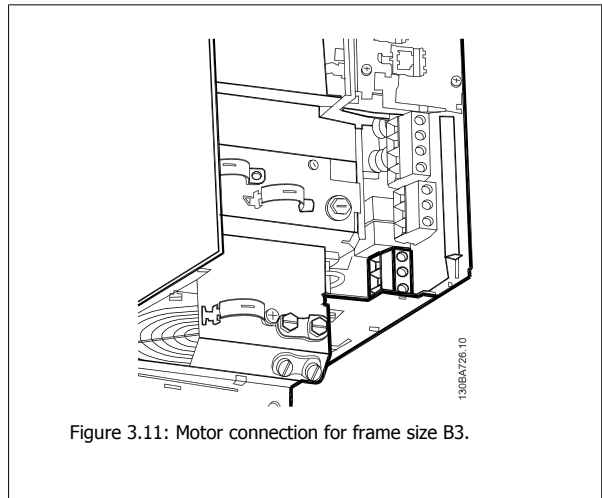

Figure 3.11: Motor connection for frame size B3.

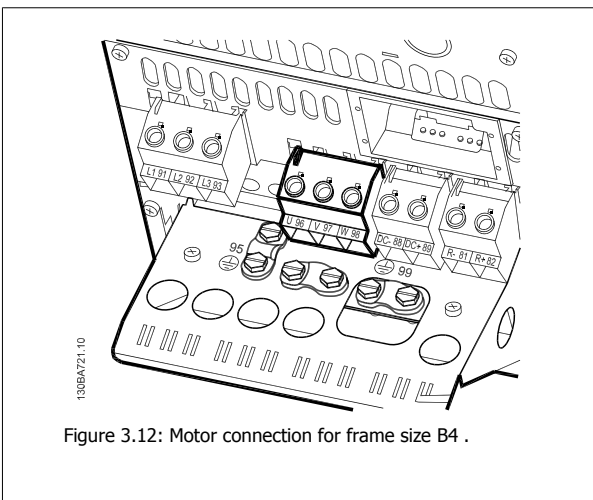

Figure 3.12: Motor connection for frame size B4 .

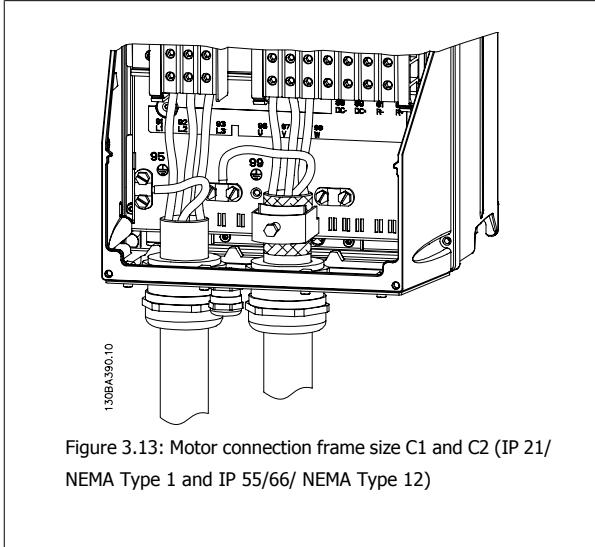

Figure 3.13: Motor connection frame size C1 and C2 (IP 21/ NEMA Type 1 and IP 55/66/ NEMA Type 12)

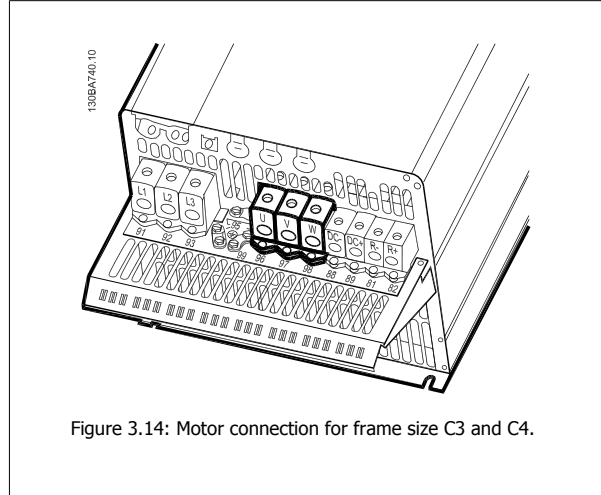

Figure 3.14: Motor connection for frame size C3 and C4.

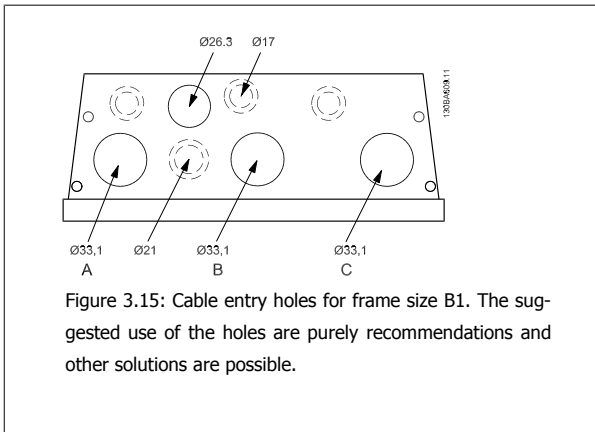

Figure 3.15: Cable entry holes for frame size B1. The suggested use of the holes are purely recommendations and other solutions are possible.

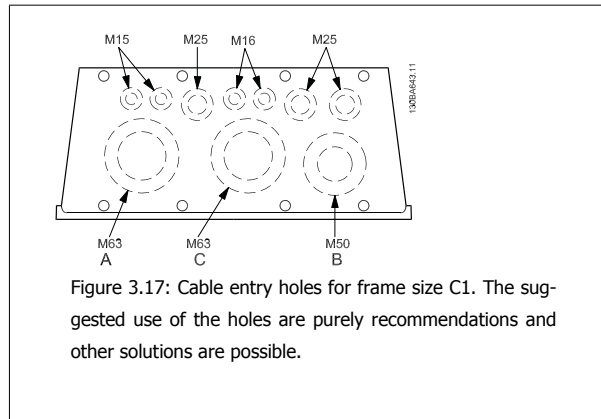

Figure 3.17: Cable entry holes for frame size C1. The suggested use of the holes are purely recommendations and other solutions are possible.

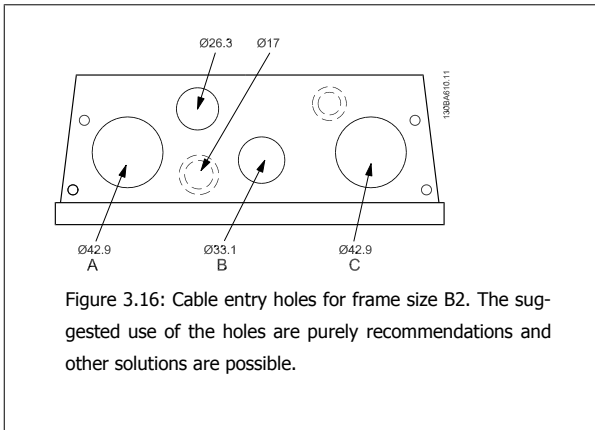

Figure 3.16: Cable entry holes for frame size B2. The suggested use of the holes are purely recommendations and other solutions are possible.

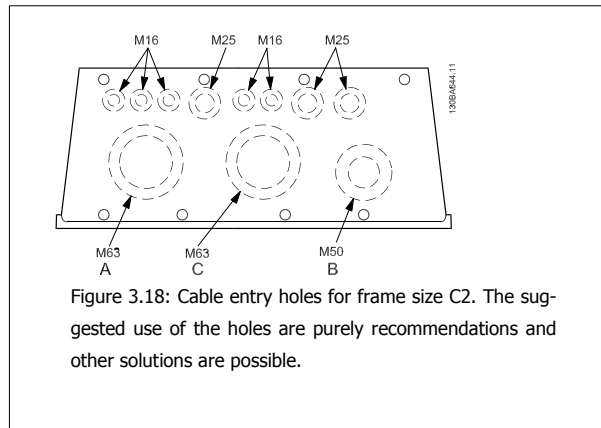
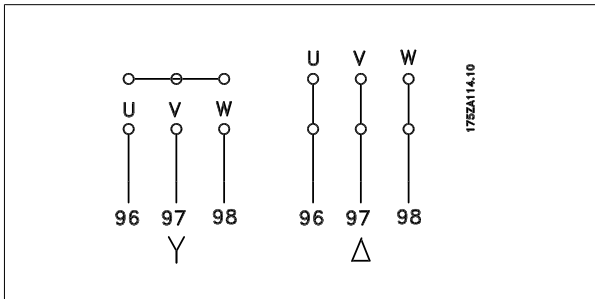

Figure 3.18: Cable entry holes for frame size C2. The suggested use of the holes are purely recommendations and other solutions are possible.

Term. no.	96	97	98	99	
	U	V	W	PE <sup>1)</sup>	Motor voltage 0–100% of AC line voltage. 3 wires out of motor
	U1	V1	W1	PE <sup>1)</sup>	Delta-connected
	W2	U2	V2		6 wires out of motor
	U1	V1	W1	PE <sup>1)</sup>	Star-connected U2, V2, W2 U2, V2 and W2 to be interconnected separately.

<sup>1)</sup>Protected Ground Connection



**NOTE!**  
 In motors without phase insulation paper or other insulation reinforcement suitable for operation with voltage supply (such as an adjustable frequency drive), fit a sine-wave filter on the output of the adjustable frequency drive.

### 3.3.4 Fuses

**Branch circuit protection:**

In order to protect the installation against electrical and fire hazards, all branch circuits in an installation, switch gear, machines, etc. must be short-circuited and overcurrent protected according to national/international regulations.

**Short-circuit protection:**

The adjustable frequency drive must be protected against short-circuit to avoid electrical or fire hazard. Danfoss recommends using the fuses mentioned below to protect service personnel and equipment in case of an internal failure in the drive. The adjustable frequency drive provides full short-circuit protection in case of a short-circuit on the motor output.

**Overcurrent protection:**

Provide overload protection to avoid fire hazard due to overheating of the cables in the installation. The adjustable frequency drive is equipped with an internal overcurrent protection that can be used for upstream overload protection (UL applications excluded). See par. 4-18 *Current Limit*. Moreover, fuses or circuit breakers can be used to provide the overcurrent protection in the installation. Overcurrent protection must always be carried out according to national regulations.

Fuses must be designed for protection in a circuit capable of supplying a maximum of 100,000 A<sub>rms</sub> (symmetrical), 500 V maximum.

**Non-UL compliance**

If UL/cUL is not to be complied with, we recommend using the following fuses, which will ensure compliance with EN50178:  
 In case of malfunction, not following the recommendation may result in unnecessary damage to the adjustable frequency drive.

Adjustable Frequency Drive Type	Max. fuse size <sup>1)</sup>	Voltage	Type
K25–K75	10A	200–240 V	type gG
1K1–2K2	20A	200–240 V	type gG
3K0–3K7	32A	200–240 V	type gG
5K5–7K5	63A	200–240 V	type gG
11K	80A	200–240 V	type gG
15K–18K5	125A	200–240 V	type gG
22K	160A	200–240 V	type aR
30K	200A	200–240 V	type aR
37K	250A	200–240 V	type aR

1) Max. fuses - refer to national/international regulations to select an appropriate fuse size.



Adjustable Frequency Drive Type	Max. fuse size <sup>1)</sup>	Voltage	Type
K37-1K5	10A	380-500 V	type gG
2K2-4K0	20A	380-500 V	type gG
5K5-7K5	32A	380-500 V	type gG
11K-18K	63A	380-500 V	type gG
22K	80A	380-500 V	type gG
30K	100A	380-500 V	type gG
37K	125A	380-500 V	type gG
45K	160A	380-500 V	type aR
55K-75K	250A	380-500 V	type aR

**UL Compliance**

200-240 V

Adjustable Frequency Drive Type	Bussmann	Bussmann	Bussmann	Bussmann	Bussmann	Bussmann
kW	Type RK1	Type J	Type T	Type CC	Type CC	Type CC
K25-K37	KTN-R05	JKS-05	JJN-06	FNQ-R-5	KTK-R-5	LP-CC-5
K55-1K1	KTN-R10	JKS-10	JJN-10	FNQ-R-10	KTK-R-10	LP-CC-10
1K5	KTN-R15	JKS-15	JJN-15	FNQ-R-15	KTK-R-15	LP-CC-15
2K2	KTN-R20	JKS-20	JJN-20	FNQ-R-20	KTK-R-20	LP-CC-20
3K0	KTN-R25	JKS-25	JJN-25	FNQ-R-25	KTK-R-25	LP-CC-25
3K7	KTN-R30	JKS-30	JJN-30	FNQ-R-30	KTK-R-30	LP-CC-30
5K5	KTN-R50	KS-50	JJN-50	-	-	-
7K5	KTN-R60	JKS-60	JJN-60	-	-	-
11K	KTN-R80	JKS-80	JJN-80	-	-	-
15K-18K5	KTN-R125	JKS-150	JJN-125	-	-	-

Adjustable Frequency Drive Type	SIBA	Littel fuse	Ferraz-Shawmut	Ferraz-Shawmut
kW	Type RK1	Type RK1	Type CC	Type RK1
K25-K37	5017906-005	KLN-R05	ATM-R05	A2K-05R
K55-1K1	5017906-010	KLN-R10	ATM-R10	A2K-10R
1K5	5017906-016	KLN-R15	ATM-R15	A2K-15R
2K2	5017906-020	KLN-R20	ATM-R20	A2K-20R
3K0	5017906-025	KLN-R25	ATM-R25	A2K-25R
3K7	5012406-032	KLN-R30	ATM-R30	A2K-30R
5K5	5014006-050	KLN-R50	-	A2K-50R
7K5	5014006-063	KLN-R60	-	A2K-60R
11K	5014006-080	KLN-R80	-	A2K-80R
15K-18K5	2028220-125	KLN-R125	-	A2K-125R

Adjustable Frequency Drive Type	Bussmann	SIBA	Littel fuse	Ferraz-Shawmut
kW	Type JFHR2	Type RK1	JFHR2	JFHR2
22K	FWX-150	2028220-150	L25S-150	A25X-150
30K	FWX-200	2028220-200	L25S-200	A25X-200
37K	FWX-250	2028220-250	L25S-250	A25X-250

KTS fuses from Bussmann may substitute for KTN for 240 V adjustable frequency drives.

FWH fuses from Bussmann may substitute for FWX for 240 V adjustable frequency drives.

KLSR fuses from LITTEL FUSE may substitute for KLN-R fuses for 240 V adjustable frequency drives.

L50S fuses from LITTEL FUSE may substitute for L50S fuses for 240 V adjustable frequency drives.

A6KR fuses from FERRAZ SHAWMUT may substitute for A2KR for 240 V adjustable frequency drives.

A50X fuses from FERRAZ SHAWMUT may substitute for A25X for 240 V adjustable frequency drives.

## 380–500 V

Adjustable Frequency Drive Type	Bussmann	Bussmann	Bussmann	Bussmann	Bussmann	Bussmann
kW	Type RK1	Type J	Type T	Type CC	Type CC	Type CC
K37–1K1	KTS-R6	JKS-6	JJS-6	FNQ-R-6	KTK-R-6	LP-CC-6
1K5–2K2	KTS-R10	JKS-10	JJS-10	FNQ-R-10	KTK-R-10	LP-CC-10
3K0	KTS-R15	JKS-15	JJS-15	FNQ-R-15	KTK-R-15	LP-CC-15
4K0	KTS-R20	JKS-20	JJS-20	FNQ-R-20	KTK-R-20	LP-CC-20
5K5	KTS-R25	JKS-25	JJS-25	FNQ-R-25	KTK-R-25	LP-CC-25
7K5	KTS-R30	JKS-30	JJS-30	FNQ-R-30	KTK-R-30	LP-CC-30
11K	KTS-R40	JKS-40	JJS-40	-	-	-
15K	KTS-R50	JKS-50	JJS-50	-	-	-
18K	KTS-R60	JKS-60	JJS-60	-	-	-
22K	KTS-R80	JKS-80	JJS-80	-	-	-
30K	KTS-R100	JKS-100	JJS-100	-	-	-
37K	KTS-R125	JKS-150	JJS-150	-	-	-
45K	KTS-R150	JKS-150	JJS-150	-	-	-

Adjustable Frequency Drive Type	SIBA	Littel fuse	Ferraz-Shawmut	Ferraz-Shawmut
kW	Type RK1	Type RK1	Type CC	Type RK1
K37–1K1	5017906-006	KLS-R6	ATM-R6	A6K-6R
1K5–2K2	5017906-010	KLS-R10	ATM-R10	A6K-10R
3K0	5017906-016	KLS-R15	ATM-R15	A6K-15R
4K0	5017906-020	KLS-R20	ATM-R20	A6K-20R
5K5	5017906-025	KLS-R25	ATM-R25	A6K-25R
7K5	5012406-032	KLS-R30	ATM-R30	A6K-30R
11K	5014006-040	KLS-R40	-	A6K-40R
15K	5014006-050	KLS-R50	-	A6K-50R
18K	5014006-063	KLS-R60	-	A6K-60R
22K	2028220-100	KLS-R80	-	A6K-80R
30K	2028220-125	KLS-R100	-	A6K-100R
37K	2028220-125	KLS-R125	-	A6K-125R
45K	2028220-160	KLS-R150	-	A6K-150R

Adjustable Frequency Drive Type	Bussmann	Bussmann	Bussmann	Bussmann
kW	JFHR2	Type H	Type T	JFHR2
55K	FWH-200	-	-	-
75K	FWH-250	-	-	-

Adjustable Frequency Drive Type	SIBA	Littel fuse	Ferraz-Shawmut	Ferraz-Shawmut
kW	Type RK1	JFHR2	JFHR2	JFHR2
55K	2028220-200	L50S-225	-	A50-P225
75K	2028220-250	L50S-250	-	A50-P250

Ferraz-Shawmut A50QS fuses may be substituted for A50P fuses.

170M fuses shown from Bussmann use the -/80 visual indicator. –TN/80 Type T, -/110 or TN/110 Type T indicator fuses of the same size and amperage may be substituted.

## 550–600V

Adjustable Frequency Drive Type	Bussmann	Bussmann	Bussmann	Bussmann	Bussmann	Bussmann
kW	Type RK1	Type J	Type T	Type CC	Type CC	Type CC
K75–1K5	KTS-R-5	JKS-5	JJS-6	FNQ-R-5	KTK-R-5	LP-CC-5
2K2–4K0	KTS-R10	JKS-10	JJS-10	FNQ-R-10	KTK-R-10	LP-CC-10
5K5–7K5	KTS-R20	JKS-20	JJS-20	FNQ-R-20	KTK-R-20	LP-CC-20

Adjustable Frequency Drive Type	SIBA	Littel fuse	Ferraz-Shawmut
kW	Type RK1	Type RK1	Type RK1
K75–1K5	5017906-005	KLSR005	A6K-5R
2K2–4K0	5017906-010	KLSR010	A6K-10R
5K5–7K5	5017906-020	KLSR020	A6K-20R

Adjustable Frequency Drive Type	Bussmann	SIBA	Ferraz-Shawmut
kW	JFHR2	Type RK1	Type RK1
P37K	170M3013	2061032.125	6.6URD30D08A0125
P45K	170M3014	2061032.160	6.6URD30D08A0160
P55K	170M3015	2061032.200	6.6URD30D08A0200
P75K	170M3015	2061032.200	6.6URD30D08A0200

170M fuses shown from Bussmann use the -/80 visual indicator. -TN/80 Type T, -/110 or TN/110 Type T indicator fuses of the same size and amperage may be substituted.

170M fuses from Bussmann when provided in the 525–600/690 V FC-302 P37K-P75K, FC-102 P75K, or FC-202 P45K-P90K drives are 170M3015.

170M fuses from Bussmann when provided in the 525–600/690 V FC-302 P90K-P132, FC-102 P90K-P132, or FC-202 P110-P160 drives are 170M3018.

170M fuses from Bussmann when provided in the 525–600/690 V FC302 P160-P315, FC-102 P160-P315, or FC-202 P200-P400 drives are 170M5011.

**3**

### 3.3.5 Access to Control Terminals

All terminals to the control cables are located underneath the terminal cover on the front of the adjustable frequency drive. Remove the terminal cover with a screwdriver.

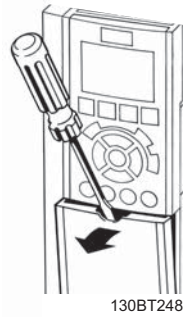

Figure 3.19: Access to control terminals for A2, A3, B3, B4, C3 and C4 enclosures

Remove front-cover to access control terminals. When replacing the front cover, ensure proper fastening by applying a torque of 2 Nm.

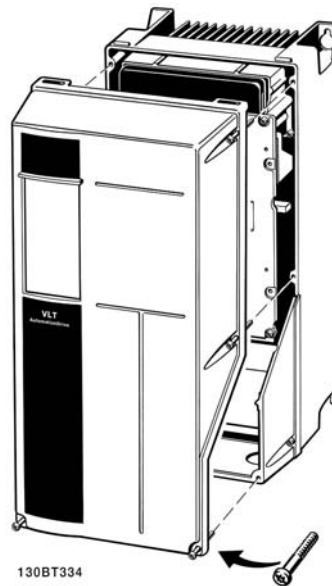

Figure 3.20: Access to control terminals for A5, B1, B2, C1 and C2 enclosures

### 3.3.6 Electrical Installation, Control Terminals

**To mount the cable to the terminal:**

1. Strip insulation of 0.34–0.39 in [9–10 mm]
2. Insert a screwdriver<sup>1)</sup> in the square hole.
3. Insert the cable in the adjacent circular hole.
4. Remove the screwdriver. The cable is now mounted to the terminal.

**To remove the cable from the terminal:**

1. Insert a screwdriver<sup>1)</sup> in the square hole.
2. Pull out the cable.

<sup>1)</sup> Max. 0.015 x 0.1 in. [0.4 x 2.5 mm]

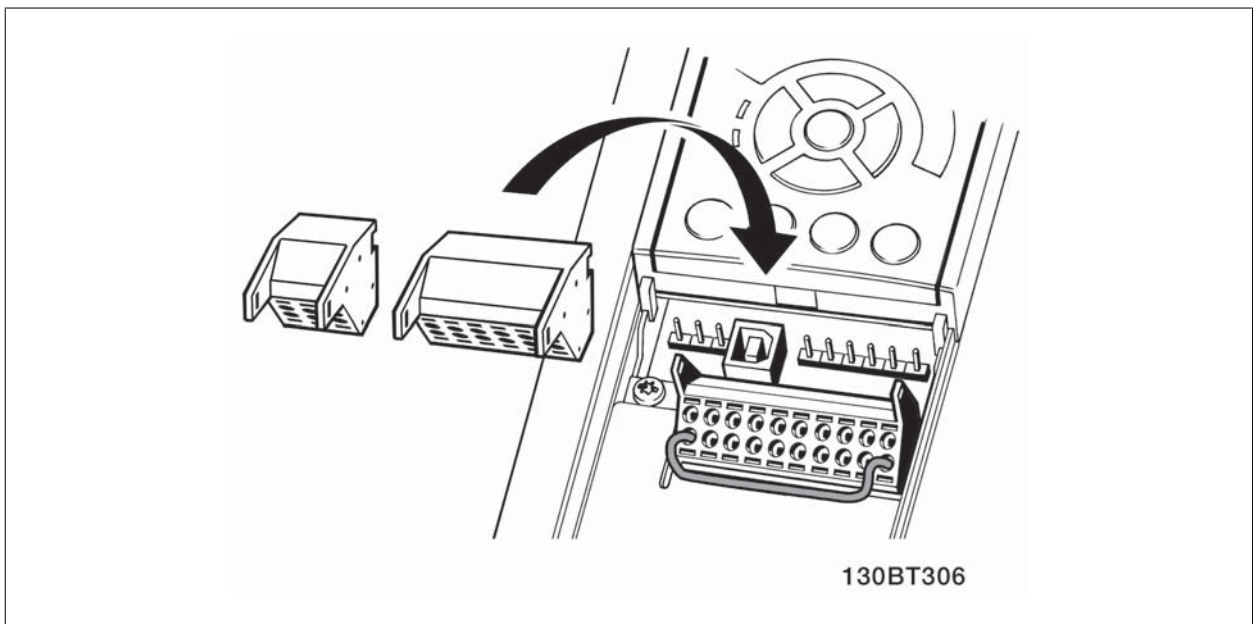
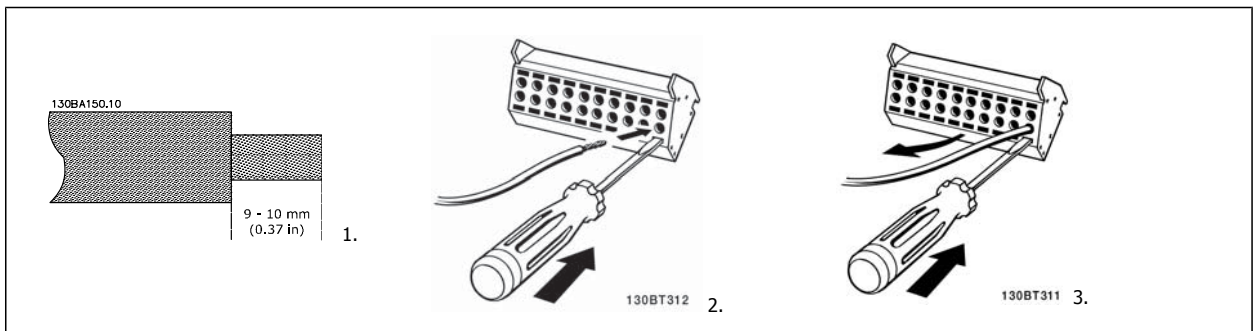

### 3.4 Connection Examples

#### 3.4.1 Start/Stop

Terminal 18 = par. 5-10 *Terminal 18 Digital Input* [8] *Start*  
 Terminal 27 = par. 5-12 *Terminal 27 Digital Input* [0] *No operation (default: coast inverse)*  
 Terminal 37 = Safe stop (where available!)

3

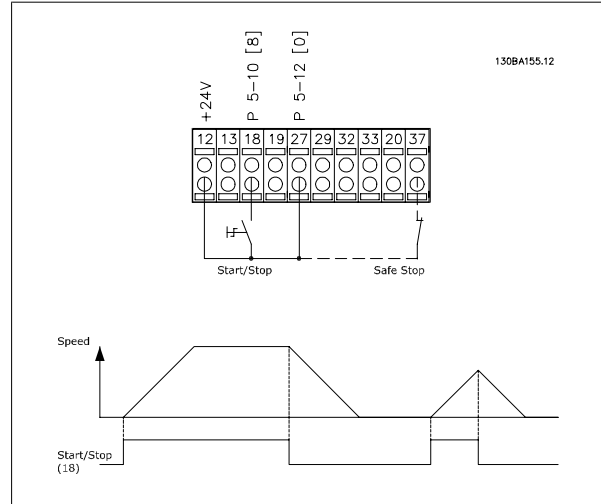

#### 3.4.2 Pulse Start/Stop

Terminal 18 = par. 5-10 *Terminal 18 Digital Input* Latched start, [9]  
 Terminal 27 = par. 5-12 *Terminal 27 Digital Input* Stop inverse, [6]  
 Terminal 37 = Safe stop (where available!)

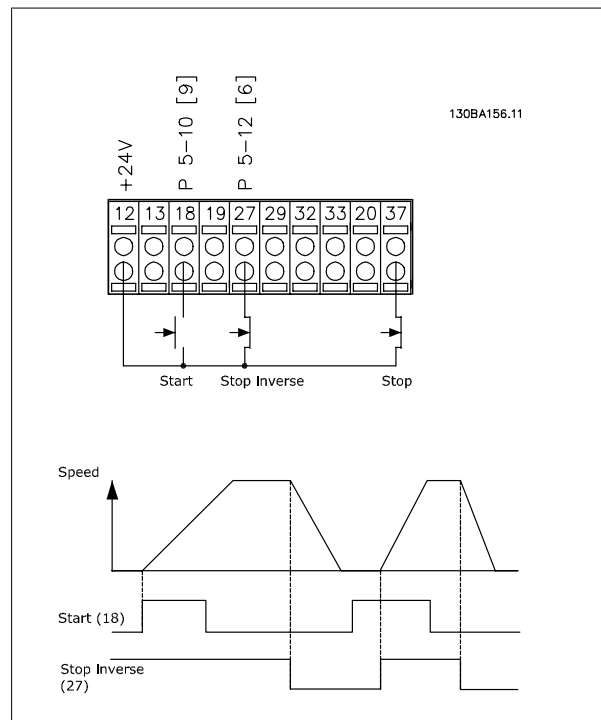

### 3.4.3 Speed Up/Down

**Terminals 29/32 = Speed up/down: .**

- Terminal 18 = Par. 5-10 [9] *Start* (default)
- Terminal 27 = Par. 5-12 [19] *Freeze reference*
- Terminal 29 = Par. 5-13 [21] *Speed up*
- Terminal 32 = Par. 5-14 [22] *Slow*

Note: Terminal 29 only in FC x02 (x=series type).

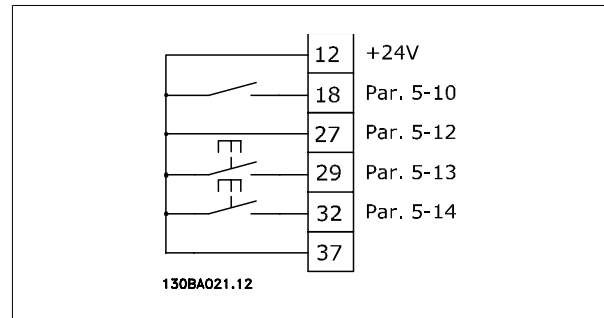

3

### 3.4.4 Potentiometer Reference

**Voltage reference via a potentiometer:**

- Reference Source 1 = [1] *Analog input 53* (default)
- Terminal 53, Low Voltage = 0 Volt
- Terminal 53, High Voltage = 10 Volt
- Terminal 53, Low Ref./Feedback = 0 RPM
- Terminal 53, High Ref./Feedback = 1,500 RPM
- Switch S201 = OFF (U)

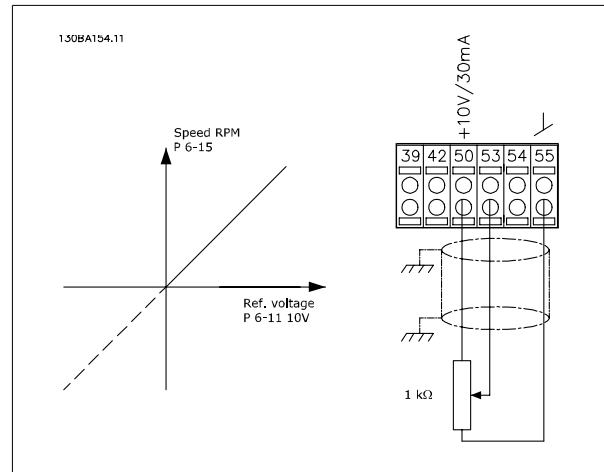

3.5.1 Electrical Installation, Control Cables

3

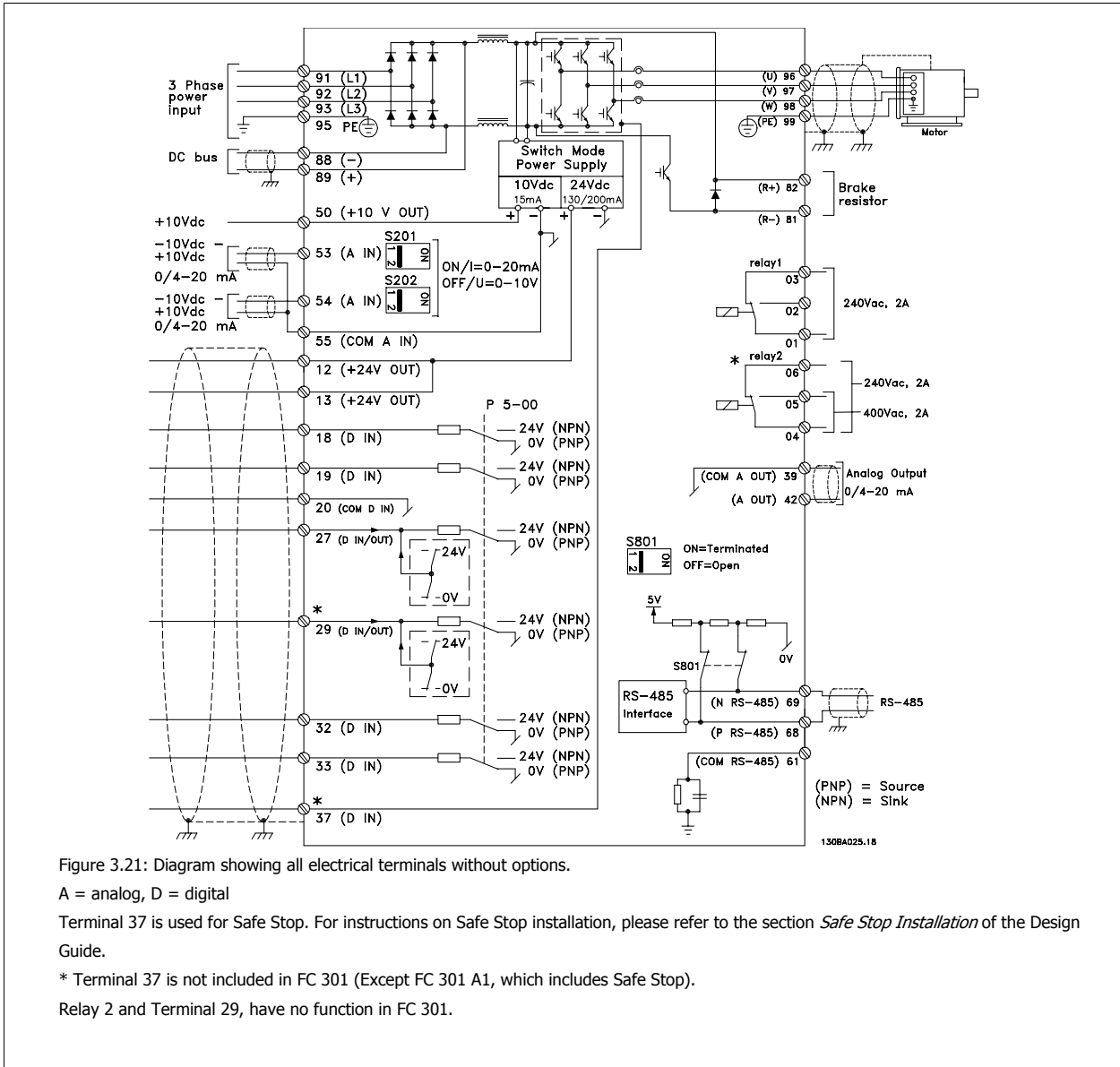

Figure 3.21: Diagram showing all electrical terminals without options.

A = analog, D = digital

Terminal 37 is used for Safe Stop. For instructions on Safe Stop installation, please refer to the section *Safe Stop Installation* of the Design Guide.

\* Terminal 37 is not included in FC 301 (Except FC 301 A1, which includes Safe Stop).

Relay 2 and Terminal 29, have no function in FC 301.

In rare cases, very long control cables and analog signals may, depending on installation, result in 50/60 Hz ground loops due to noise from line power supply cables.

If this occurs, it may be necessary to break the shield or insert a 100 nF capacitor between shield and chassis.

The digital and analog inputs and outputs must be connected separately to the common inputs (terminal 20, 55, 39) of the adjustable frequency drive to avoid ground currents from both groups to affect other groups. For example, switching on the digital input may disturb the analog input signal.



Input polarity of control terminals

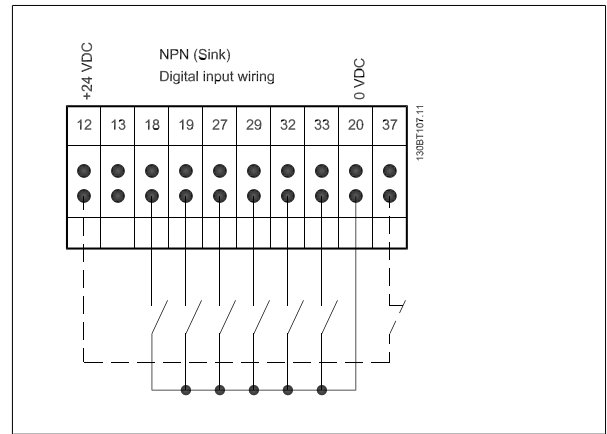
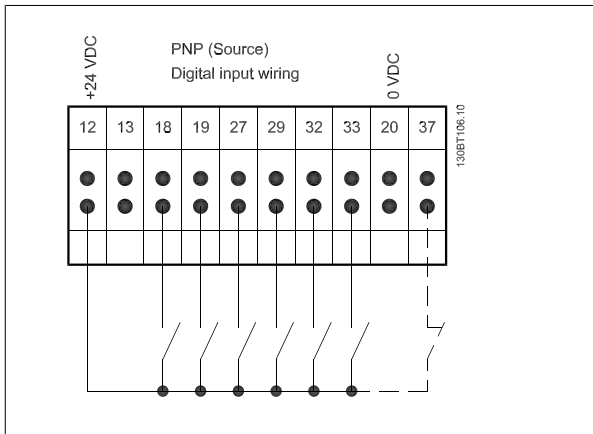

**NOTE!**

Control cables must be shielded/armored.

See the section entitled *Grounding of Shielded/Armored Control Cables* for the correct termination of control cables.

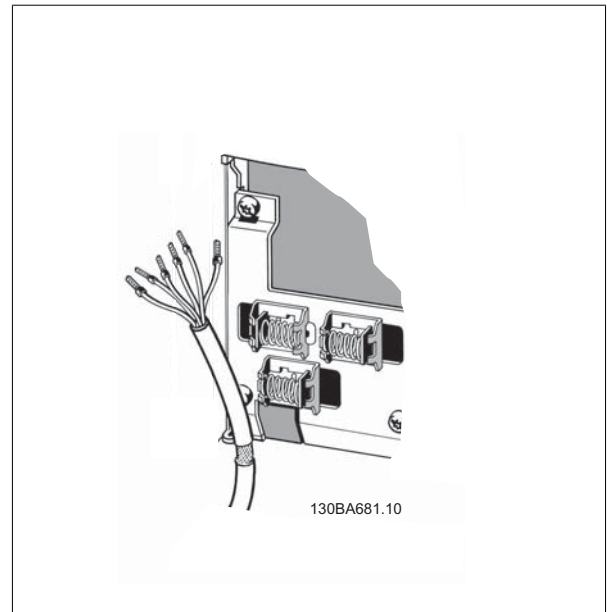

### 3.5.2 Switches S201, S202, and S801

Switches S201 (A53) and S202 (A54) are used to select a current (0-20 mA) or a voltage (-10 to 10 V) configuration for the analog input terminals 53 and 54, respectively.

Switch S801 (BUS TER.) can be used to enable termination on the RS-485 port (terminals 68 and 69).

See drawing *Diagram showing all electrical terminals* in section *Electrical Installation*.

3

**Default setting:**

S201 (A53) = OFF (voltage input)

S202 (A54) = OFF (voltage input)

S801 (Bus termination) = OFF



When changing the function of S201, S202 or S801, be careful not to force the switch over. It is recommended to remove the LCP fixture (cradle) when operating the switches. The switches must not be operated while the adjustable frequency drive is powered.

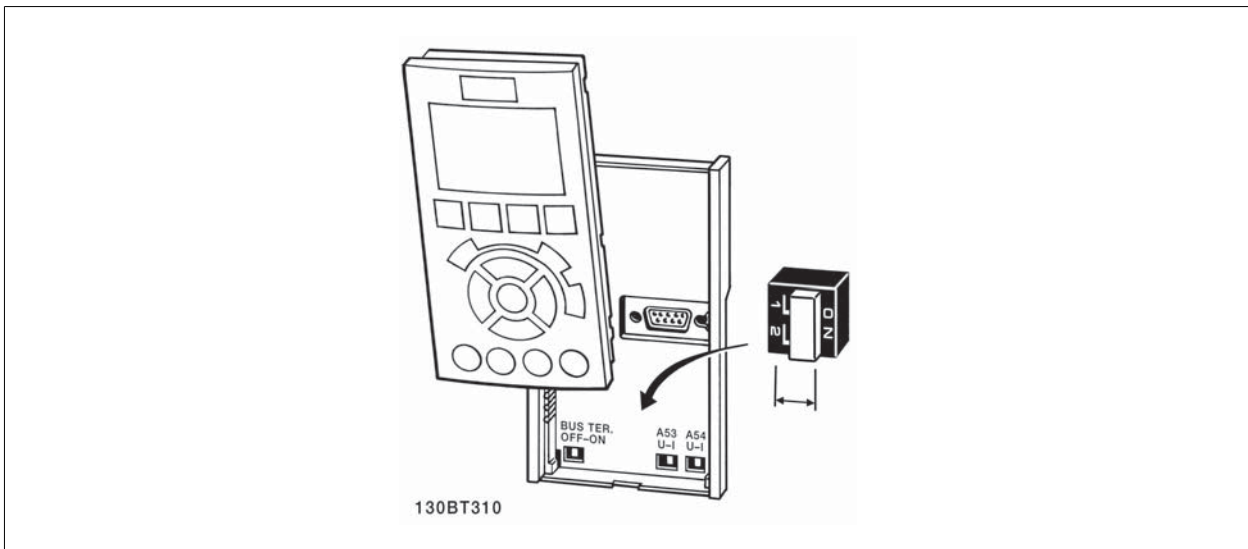

### 3.6.1 Final Set-Up and Test

To test the set-up and ensure that the adjustable frequency drive is running, follow these steps.

#### Step 1. Locate the motor nameplate

**NOTE!**  
The motor is either star- (Y) or delta-connected ( $\Delta$ ). This information is located on the motor nameplate data.

3

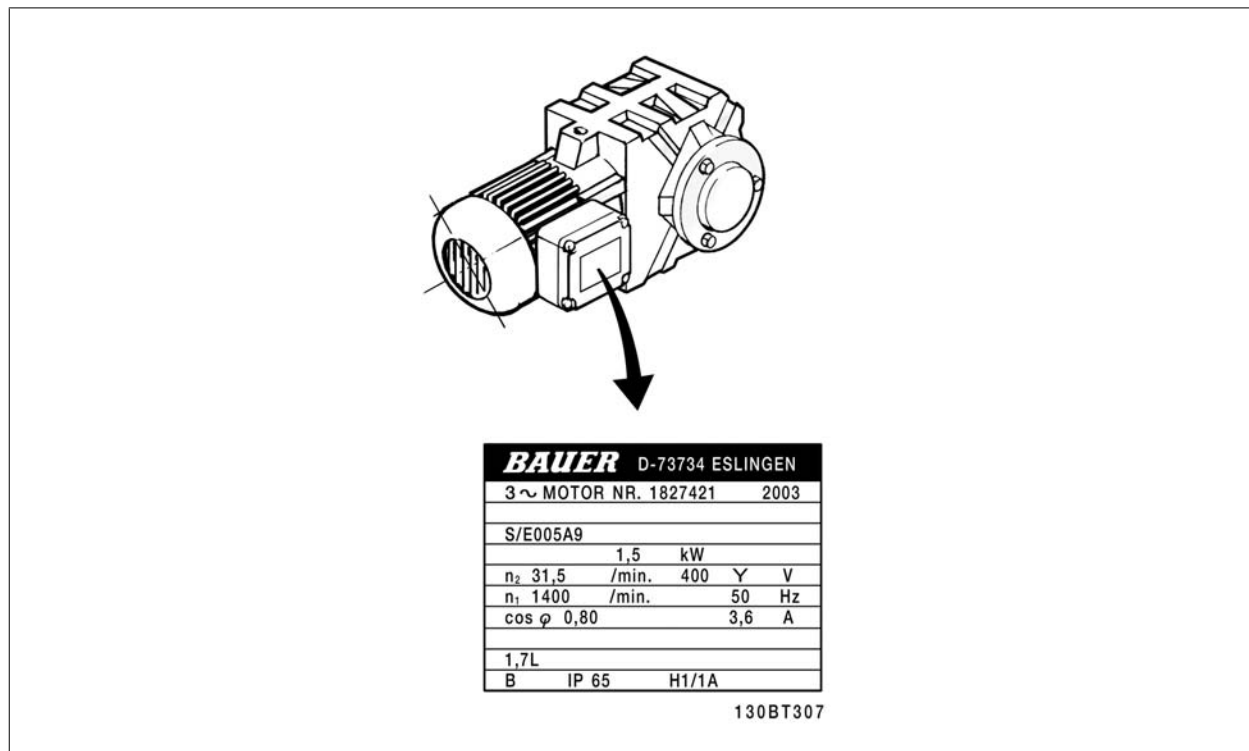

#### Step 2. Enter the motor nameplate data in this parameter list.

To access this list, first press the [QUICK MENU] key, then select "Q2 Quick Set-up".

1.	par. 1-20 <i>Motor Power [kW]</i> par. 1-21 <i>Motor Power [HP]</i>
2.	par. 1-22 <i>Motor Voltage</i>
3.	par. 1-23 <i>Motor Frequency</i>
4.	par. 1-24 <i>Motor Current</i>
5.	par. 1-25 <i>Motor Nominal Speed</i>

#### Step 3. Activate the Automatic Motor Adaptation (AMA)

Performing an AMA will ensure optimum performance. The AMA measures the values from the motor model equivalent diagram.

1. Connect terminal 37 to terminal 12 (if terminal 37 is available).
2. Connect terminal 27 to terminal 12 or set par. 5-12 *Terminal 27 Digital Input* to 'No function'.
3. Activate the AMA par. 1-29 *Automatic Motor Adaptation (AMA)*.
4. Choose between complete or reduced AMA. If a sine-wave filter is mounted, run only the reduced AMA, or remove the sine-wave filter during the AMA procedure.
5. Press the [OK] key. The display shows "Press [Hand on] to start".
6. Press the [Hand on] key. A progress bar indicates if the AMA is in progress.

#### Stop the AMA during operation

1. Press the [OFF] key - the adjustable frequency drive enters into alarm mode and the display shows that the AMA was terminated by the user.

**Successful AMA**

1. The display shows "Press [OK] to finish AMA".
2. Press the [OK] key to exit the AMA state.

**Unsuccessful AMA**

1. The adjustable frequency drive enters into alarm mode. A description of the alarm can be found in the *Warnings and Alarms* chapter.
2. "Report Value" in the [Alarm Log] shows the last measuring sequence carried out by the AMA before the adjustable frequency drive entered alarm mode. This number, along with the description of the alarm, will assist you in troubleshooting. If you contact Danfoss for service, make sure to mention the number and alarm description.

**NOTE!**

An unsuccessful AMA is often caused by incorrectly registered motor nameplate data or a difference between the motor power size and the adjustable frequency drive power size that is too large.

**Step 4. Set speed limit and ramp times**

par.3-02 *Minimum Reference*  
par.3-03 *Maximum Reference*

Table 3.4: Set up the desired limits for speed and ramp time.

par. 4-11 *Motor Speed Low Limit [RPM]* or par. 4-12 *Motor Speed Low Limit [Hz]*  
par. 4-13 *Motor Speed High Limit [RPM]* or par. 4-14 *Motor Speed High Limit [Hz]*

par. 3-41 *Ramp 1 Ramp up Time*  
par. 3-42 *Ramp 1 Ramp Down Time*

### 3.7 Additional Connections

#### 3.7.1 Mechanical Brake Control

In hoisting/lowering applications, it is necessary to be able to control an electro-mechanical brake:

- Control the brake using any relay output or digital output (terminal 27 or 29).
- Keep the output closed (voltage-free) as long as the adjustable frequency drive is unable to 'support' the motor, such as when the load is too heavy, for example.
- Select *Mechanical brake control* [32] in par. 5-4\* for applications with an electro-mechanical brake.
- The brake is released when the motor current exceeds the preset value in par.2-20 *Release Brake Current*.
- The brake is engaged when the output frequency is less than the frequency set in par.2-21 *Activate Brake Speed [RPM]* or par.2-22 *Activate Brake Speed [Hz]*, and only if the adjustable frequency drive carries out a stop command.

If the adjustable frequency drive is in alarm mode or in an overvoltage situation, the mechanical brake immediately cuts in.

#### 3.7.2 Parallel Connection of Motors

The adjustable frequency drive can control several parallel-connected motors. The total current consumption of the motors must not exceed the rated output current  $I_{M,N}$  for the adjustable frequency drive.

**NOTE!**  
Installation with cables connected in a common joint, as in the illustration below, is only recommended for short cable lengths.

**NOTE!**  
When motors are connected in parallel, par. 1-29 *Automatic Motor Adaptation (AMA)* cannot be used.

**NOTE!**  
The electronic thermal relay (ETR) of the adjustable frequency drive cannot be used as motor protection for the individual motor of systems with parallel-connected motors. Provide further motor protection with, for example, thermistors in each motor or individual thermal relays (circuit breakers are not suitable for protection).

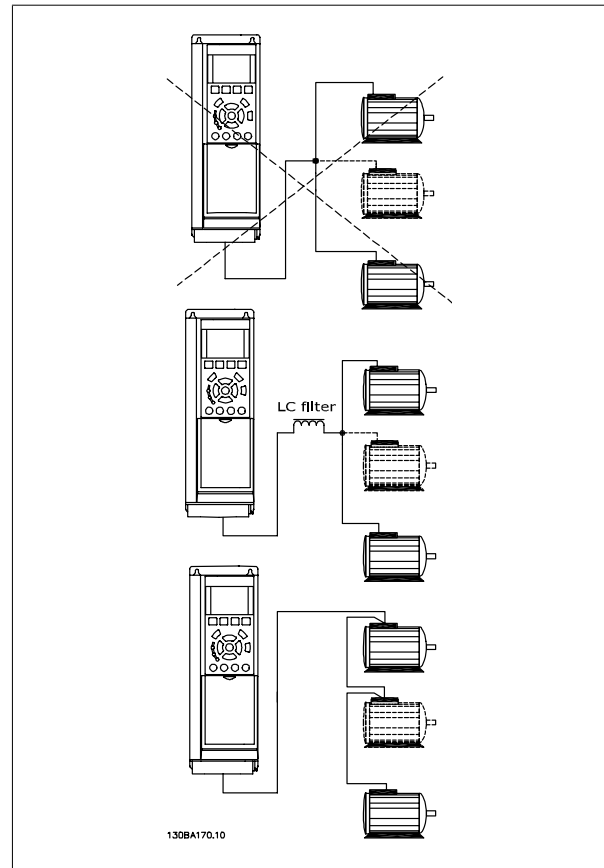

Problems may arise at start and at low RPM values if motor sizes are widely different because small motors' relatively high ohmic resistance in the stator calls for a higher voltage at start and at low RPM values.

### 3.7.3 Motor Thermal Protection

The electronic thermal relay in the adjustable frequency drive has received UL approval for single motor protection, when par.1-90 *Motor Thermal Protection* is set for *ETR Trip* and par. 1-24 *Motor Current* is set to the rated motor current (see motor nameplate).

For thermal motor protection, it is also possible to use the MCB 112 PTC thermistor card option. This card provides an ATEX certificate to protect motors in explosion hazard areas, Zone 1/21 and Zone 2/22. Please refer to the *Design Guide* for further information.

### 3 3.7.4 How to Connect a PC to the Adjustable Frequency Drive

To control the adjustable frequency drive from a PC, install the MCT 10 Set-up Software.

The PC is connected via a standard (host/device) USB cable or via the RS-485 interface as shown in the section *Bus Connection* in the Programming Guide.



#### NOTE!

The USB connection is galvanically isolated from the supply voltage (PELV) and other high-voltage terminals. The USB connection is connected to protection ground on the adjustable frequency drive. Use only isolated laptop for PC connection to the USB connector on the adjustable frequency drive.

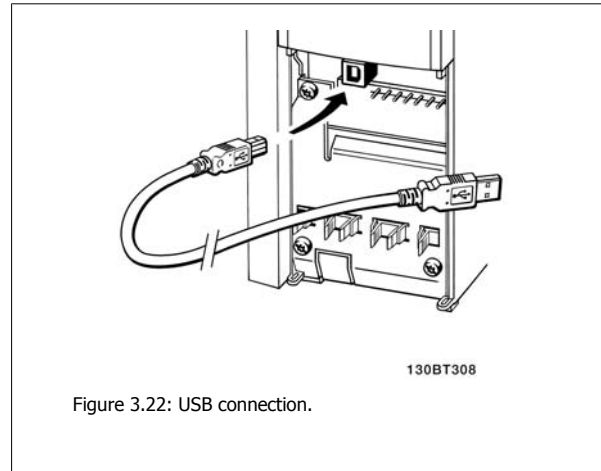

Figure 3.22: USB connection.

### 3.7.5 The FC 300 PC software

#### Data storage in PC via MCT 10 Set-Up Software:

1. Connect a PC to the unit via the USB com port.
2. Open MCT 10 Set-up Software
3. Select the USB port in the "network" section.
4. Choose "Copy".
5. Select the "project" section.
6. Choose "Paste".
7. Choose "Save as".

All parameters are now stored.

#### Data transfer from PC to drive via MCT 10 Set-Up Software:

1. Connect a PC to the unit via the USB com port.
2. Open MCT 10 Set-up software
3. Choose "Open"– stored files will be shown.
4. Open the appropriate file.
5. Choose "Write to drive."

All parameters are now transferred to the drive.

A separate manual for MCT 10 Set-up Software is available.

## 4 How to Program

### 4.1 The Graphical and Numerical LCP

The easiest way to program the adjustable frequency drive is to use the Graphical Local Control Panel (LCP 102). It is necessary to consult the adjustable frequency drive Design Guide when using the Numeric Local Control Panel (LCP 101).

#### 4.1.1 How to Program on the Graphical LCP

The following instructions are valid for the graphical LCP (LCP 102):

The control panel is divided into four functional groups:

1. Graphical display with status lines.
2. Menu keys and LEDs - changing parameters and switching between display functions.
3. Navigation keys and lights (LEDs).
4. Operation keys and LEDs.

All data is displayed in a graphical LCP display, which can show up to five items of operating data while displaying [Status].

Display lines:

- a. **Status line:** Status messages displaying icons and graphics.
- b. **Line 1-2:** Operator data lines displaying data defined or chosen by the user. By pressing the [Status] key, up to one extra line can be added.
- c. **Status line:** Status messages displaying text.

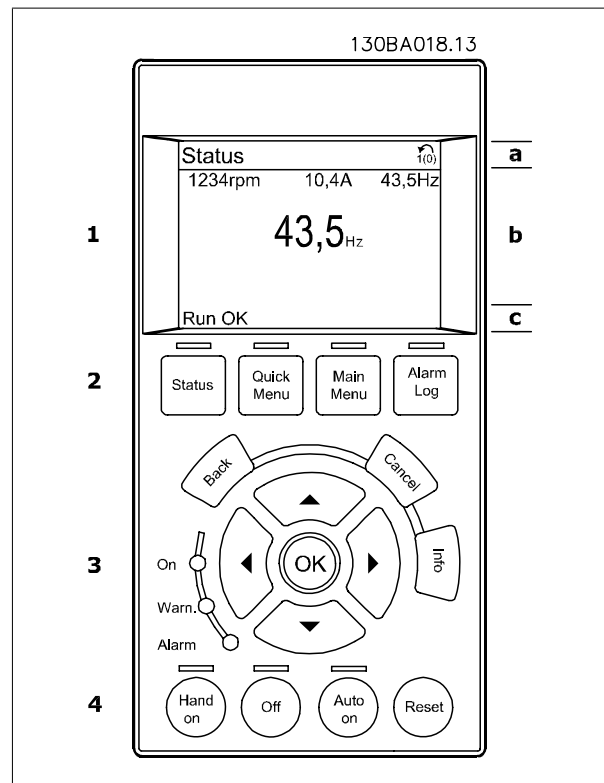

### 4.1.2 How to Program on the Numerical Local Control Panel

The following instructions are valid for the numerical LCP (LCP 101):

The control panel is divided into four functional groups:

1. Numerical display.
2. Menu keys and LEDs - changing parameters and switching between display functions.
3. Navigation keys and lights (LEDs).
4. Operation keys and LEDs.

4

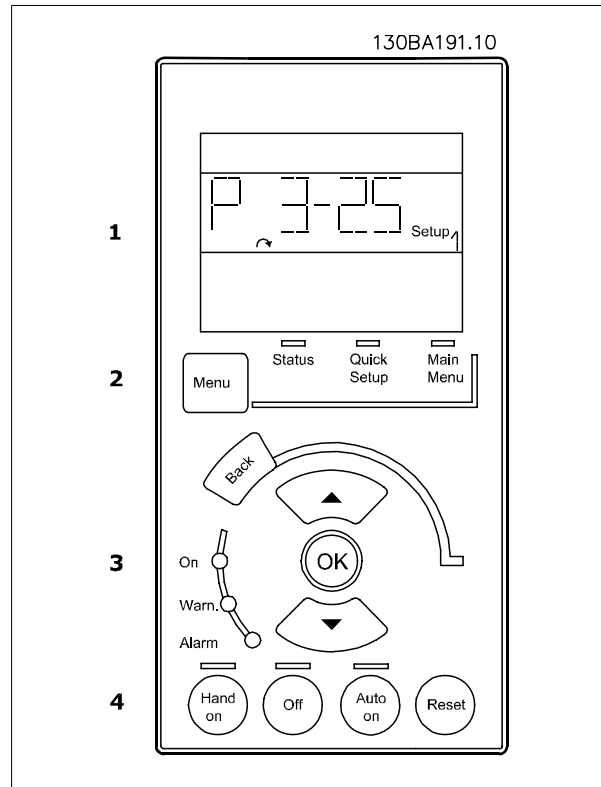



### 4.1.3 Initial Commissioning

The easiest way of carrying out the initial commissioning is by using the quick menu button and follow the quick set-up procedure using LCP 102 (read table from left to right). The example applies to open-loop applications:

Press			
		Q2 Quick Menu	
par.0-01 <i>Language</i>		Set language	
par. 1-20 <i>Motor Power [kW]</i>		Set motor nameplate power	
par. 1-22 <i>Motor Voltage</i>		Set nameplate voltage	
par. 1-23 <i>Motor Frequency</i>		Set nameplate frequency	
par. 1-24 <i>Motor Current</i>		Set nameplate current	
par. 1-25 <i>Motor Nominal Speed</i>		Set nameplate speed in RPM	
par. 5-12 <i>Terminal 27 Digital Input</i>		If terminal default is <i>Coast inverse</i> , it is possible to change this setting to <i>No function</i> . No connection to terminal 27 is then needed for running AMA	
par. 1-29 <i>Automatic Motor Adaptation (AMA)</i>		Set desired AMA function. Enable complete AMA is recommended	
par.3-02 <i>Minimum Reference</i>		Set the minimum speed of the motor shaft	
par.3-03 <i>Maximum Reference</i>		Set the maximum speed of the motor shaft	
par. 3-41 <i>Ramp 1 Ramp up Time</i>		Set the ramping-up time with reference to synchronous motor speed, ns.	 
par. 3-42 <i>Ramp 1 Ramp Down Time</i>		Set the ramping-down time with reference to synchronous motor speed, ns.	
par. 3-13 <i>Reference Site</i>		Set the site from where the reference must work	

## 4.2 Quick Setup

### 0-01 Language

#### Option:

#### Function:

Defines the language to be used in the display.

The adjustable frequency drive can be delivered with 4 different language packages. English and German are included in all packages. English cannot be erased or manipulated.

[0] *	English	Part of Language packages 1 - 4
[1]	Deutsch	Part of Language packages 1 - 4
[2]	Francais	Part of Language package 1
[3]	Dansk	Part of Language package 1
[4]	Spanish	Part of Language package 1
[5]	Italiano	Part of Language package 1
[6]	Svenska	Part of Language package 1
[7]	Nederlands	Part of Language package 1
[10]	Chinese	Language package 2
[20]	Suomi	Part of Language package 1
[22]	English US	Part of Language package 4
[27]	Greek	Part of Language package 4
[28]	Bras.port	Part of Language package 4
[36]	Slovenian	Part of Language package 3
[39]	Korean	Part of Language package 2
[40]	Japanese	Part of Language package 2
[41]	Turkish	Part of Language package 4
[42]	Trad.Chinese	Part of Language package 2
[43]	Bulgarian	Part of Language package 3
[44]	Srpski	Part of Language package 3
[45]	Romanian	Part of Language package 3
[46]	Magyar	Part of Language package 3
[47]	Czech	Part of Language package 3
[48]	Polski	Part of Language package 4
[49]	Russian	Part of Language package 3
[50]	Thai	Part of Language package 2
[51]	Bahasa Indonesia	Part of Language package 2

**1-20 Motor Power**

**Range:**

Size rela- [0.12-1600 hp [0.09-1200 kW]]  
ted\*

**Function:**

Enter the nominal motor power (in kW) according to the motor nameplate data. The default value corresponds to the nominal rated output of the unit.

This parameter cannot be adjusted while the motor is running. This parameter is visible in LCP if par. 0-03 is *International* [0].

**NOTE!**  
Four sizes down, one size up from the nominal VLT rating.

**1-22 Motor Voltage**

**Range:**

400. V\* [10. - 1000. V]

**Function:**

Enter the nominal motor voltage according to the motor nameplate data. The default value corresponds to the nominal rated output of the unit.

This parameter cannot be adjusted while the motor is running.

**1-23 Motor Frequency**

**Option:**

**Function:**

Min - Max motor frequency: 20 - 1,000 Hz

Select the motor frequency value from the motor nameplate data. If a value different from 50 Hz or 60 Hz is selected, it is necessary to adapt the load independent settings in par. 1-50 to 1-53. For 87 Hz operation with 230/400 V motors, set the nameplate data for 230 V/50 Hz. Adapt par. 4-13 *Motor Speed High Limit [RPM]* and par. 3-03 *Maximum Reference* to the 87 Hz application.

[50] \* 50 Hz when parameter 0-03 = international

[60] 60 Hz when parameter 0-03 = US

**1-24 Motor Current**

**Range:**

7.20 A\* [0.10 - 10000.00 A]

**Function:**

Enter the nominal motor current value from the motor nameplate data. This data is used for calculating motor torque, motor thermal protection, etc.

**NOTE!**  
This parameter cannot be adjusted while the motor is running.

**1-25 Motor Nominal Speed**

**Range:**

1420. RPM\* [100 - 60000 RPM]

**Function:**

Enter the nominal motor speed value from the motor nameplate data. This data is used for calculating automatic motor compensations.

**NOTE!**  
This parameter cannot be changed while the motor is running.

**5-12 Terminal 27 Digital Input**

**Option:**

**Function:**

Select the function from the available digital input range.

No operation	[0]
Reset	[1]
Coast inverse	[2]
Coast and reset inverse	[3]
Quick stop inverse	[4]
DC brake inverse	[5]
Stop inverse	[6]
Start	[8]
Latched start	[9]
Reversing	[10]
Start reversing	[11]
Enable start forward	[12]
Enable start reverse	[13]
Jog	[14]
Preset ref bit 0	[16]
Preset ref bit 1	[17]
Preset ref bit 2	[18]
Freeze reference	[19]
Freeze output	[20]
Speed up	[21]
Slow	[22]
Set-up select bit 0	[23]
Set-up select bit 1	[24]
Catch up	[28]
Slow-down	[29]
Pulse input	[32]
Ramp bit 0	[34]
Ramp bit 1	[35]
Line failure inverse	[36]
DigiPot Increase	[55]
DigiPot Decrease	[56]
DigiPot Clear	[57]
Reset Counter A	[62]
Reset Counter B	[65]

**1-29 Automatic Motor Adaptation (AMA)**

**Option:**

**Function:**

The AMA function optimizes dynamic motor performance by automatically optimizing the advanced motor parameters (par. 1-30 to par. 1-35) during motor standstill.  
 Activate the AMA function by pressing [Hand on] after selecting [1] or [2]. See also the section *Automatic Motor Adaptation*. After a normal sequence, the display will read: "Press [OK] to finish AMA". After pressing the [OK] key, the adjustable frequency drive is ready for operation.  
 This parameter cannot be adjusted while the motor is running.

[0] *	OFF	
[1]	Enable complete AMA	Performs AMA of the stator resistance $R_s$ , the rotor resistance $R_r$ , the stator leakage reactance $X_1$ , the rotor leakage reactance $X_2$ and the main reactance $X_h$ .  FC 301: The complete AMA does not include $X_h$ measurement for the FC 301. Instead, the $X_h$ value is determined from the motor database. Par. 1-35 may be adjusted to obtain optimal start performance.
[2]	Enable reduced AMA	Performs a reduced AMA of the stator resistance $R_s$ in the system only. Select this option if an LC filter is used between the drive and the motor.

**Note:**

- For the best adaptation of the adjustable frequency drive, run the AMA on a cold motor.
- AMA cannot be performed while the motor is running.
- AMA cannot be performed on permanent magnet motors.



**NOTE!**  
It is important to set motor par. 1-2\* correctly, since these form part of the AMA algorithm. An AMA must be performed to achieve optimum dynamic motor performance. It may take up to 10 min, depending on the power rating of the motor.



**NOTE!**  
Avoid generating external torque during AMA.



**NOTE!**  
If one of the settings in par. 1-2\* is changed, par. 1-30 to par. 1-39, the advanced motor parameters, will return to default setting.

**3-02 Minimum Reference**

<b>Range:</b> 0 Referen- [-999999.999 - par. 3-03 Referen- ceFeedback-ceFeedbackUnit] Unit*	<b>Function:</b> Enter the Minimum Reference. The Minimum Reference is the lowest value obtainable by adding all references together. Minimum Reference is active only when par. 3-00 <i>Reference Range</i> is set to <i>Min.- Max.</i> [0]. The minimum reference unit matches: <ul style="list-style-type: none"> <li>• The choice of configuration in par. 1-00 <i>Configuration Mode Configuration Mode: for Speed closed-loop</i> [1], RPM; for <i>Torque</i> [2], Nm.</li> <li>• The unit selected in par. 3-01 <i>Reference/Feedback Unit</i>.</li> </ul>
--	--

**3-03 Maximum Reference**

<b>Range:</b> 1500.000 [par. 3-02 - 999999.999 Referen- Reference- ceFeedbackUnit] FeedbackU- nit*	<b>Function:</b> Enter the maximum reference. The maximum reference is the highest value obtainable by adding all references together.  <b>The Maximum Reference unit matches:</b> <ul style="list-style-type: none"> <li>• The choice of configuration in par. 1-00 <i>Configuration Mode: for Speed closed-loop</i> [1], RPM; for <i>Torque</i> [2], Nm.</li> <li>• The unit selected in par. 3-0.</li> </ul>
--	--

**3-41 Ramp 1 Ramp-up Time**

<b>Range:</b> Size related [0.01-3600.00 s]	<b>Function:</b> Enter the ramp-up time, i.e. the acceleration time from 0 RPM to the synchronous motor speed $n_s$ . Choose a ramp-up time such that the output current does not exceed the current limit in par. 4-18 during ramping. The value 0.00 corresponds to 0.01 sec. in speed mode. See ramp-down time in par. 3-42.  $Par. 3 - 41 = \frac{t_{acc}[s] \times n_s [RPM]}{\Delta ref [RPM]}$
--	--

### 3-42 Ramp 1 Ramp-down Time

**Range:**

Size related [0.01-3600.00 s]

**Function:**

Enter the ramp-down time, i.e. the deceleration time from the synchronous motor speed  $n_s$  to 0 RPM. Choose a ramp-down time so that no overvoltage arises in the inverter due to regenerative operation of the motor, and so that the generated current does not exceed the current limit set in par. 4-18. The value 0.00 corresponds to 0.01 s in speed mode. See ramp-up time in par. 3-41.

$$Par. 3 - 42 = \frac{t_{dec} [s] \times n_s [RPM]}{\Delta ref [RPM]}$$

## 4.3 Basic set-up parameters

# 4

### 0-02 Motor Speed Unit

**Option:**
**Function:**

This parameter cannot be adjusted while the motor is running.  
The display showing depends on settings in par.0-02 *Motor Speed Unit* and par. 0-03 *Regional Settings*. The default setting of par.0-02 *Motor Speed Unit* and par. 0-03 *Regional Settings* depends on which region of the world the adjustable frequency drive is supplied to, but can be re-programmed as required.

**NOTE!**

Changing the *Motor Speed Unit* will reset certain parameters to their initial value. It is recommended to select the motor speed unit first before modifying other parameters.

[0]	RPM	Selects display of motor speed variables and parameters (i.e. references, feedbacks and limits) in terms of motor speed (RPM).
[1] *	Hz	Selects display of motor speed variables and parameters (i.e., references, feedbacks and limits) in terms of output frequency to the motor (Hz).

### 0-50 LCP Copy

**Option:**
**Function:**

[0] *	No copy	
[1]	All to LCP	Copies all parameters in all set-ups from the adjustable frequency drive memory to the LCP memory.
[2]	All from LCP	Copies all parameters in all set-ups from the LCP memory to the adjustable frequency drive memory.
[3]	Size indep. from LCP	copy only the parameters that are independent of the motor size. The latter selection can be used to program several adjustable frequency drives with the same function without disturbing motor data.
[4]	File from MCO to LCP	
[5]	File from LCP to MCO	

This parameter cannot be adjusted while the motor is running.

### 1-03 Torque Characteristics

**Option:**
**Function:**

Select the torque characteristic required.  
VT and AEO are both energy saving operations.

[0] *	Constant torque	Motor shaft output provides constant torque under variable speed control.
-------	-----------------	---



4

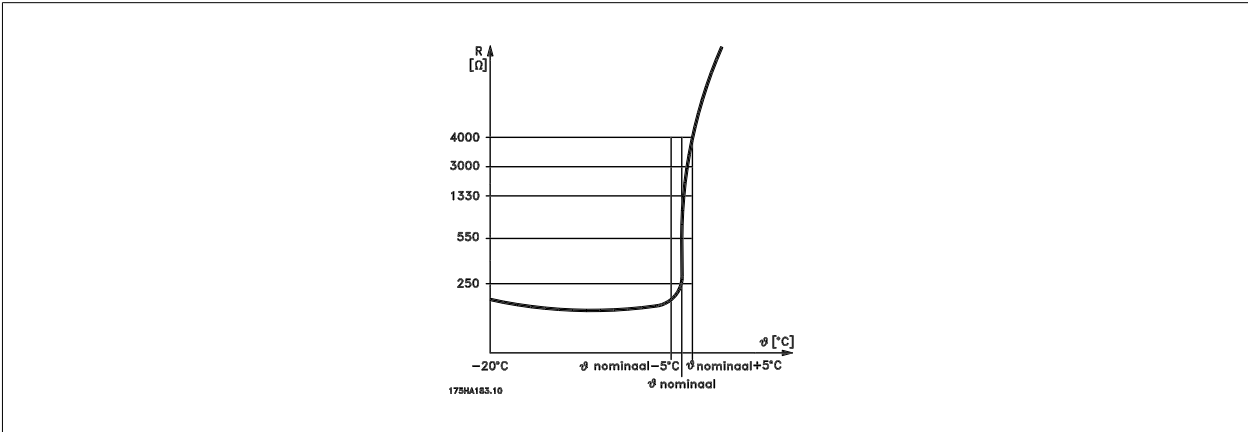

Motor protection can be implemented using a range of techniques: PTC or KTY sensor (see also section *KTY Sensor Connection*) in motor windings; mechanical thermal switch (Klixon type); or Electronic Thermal Relay (ETR).

When using a digital input and 24 V as power supply:

Example: The adjustable frequency drive trips when the motor temperature is too high

Parameter set-up:

Set par.1-90 *Motor Thermal Protection to Thermistor Trip* [2]

Set par.1-93 *Thermistor Source to Digital Input* [6]

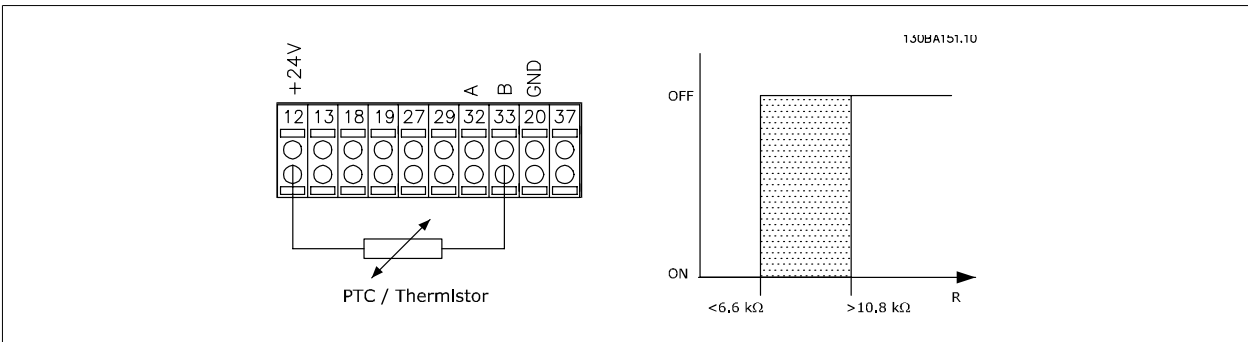

When using a digital input and 10 V as power supply:

Example: The adjustable frequency drive trips when the motor temperature is too high.

Parameter set-up:

Set par.1-90 *Motor Thermal Protection to Thermistor Trip* [2]

Set par.1-93 *Thermistor Source to Digital Input* [6]

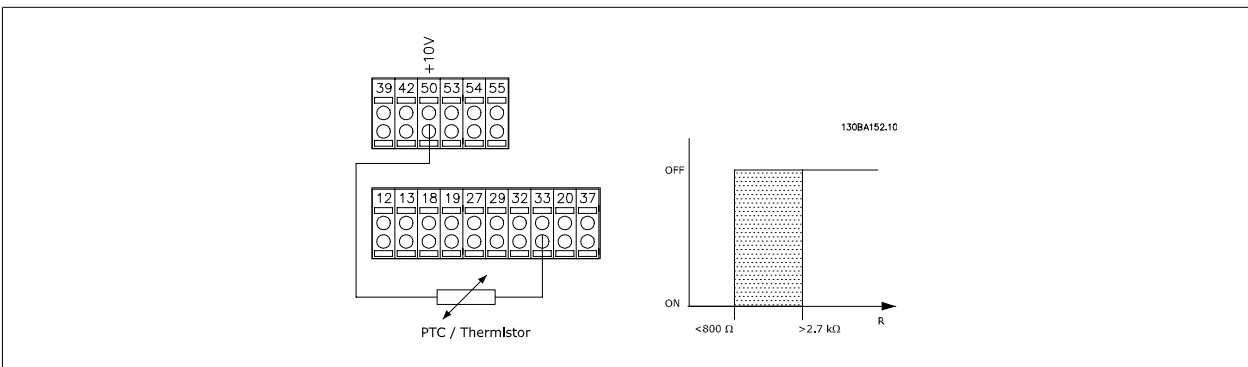



When using an analog input and 10 V as power supply:

Example: The adjustable frequency drive trips when the motor temperature is too high.

Parameter set-up:

Set par.1-90 *Motor Thermal Protection* to *Thermistor Trip* [2]

Set par.1-93 *Thermistor Source* to *Analog Input 54* [2]

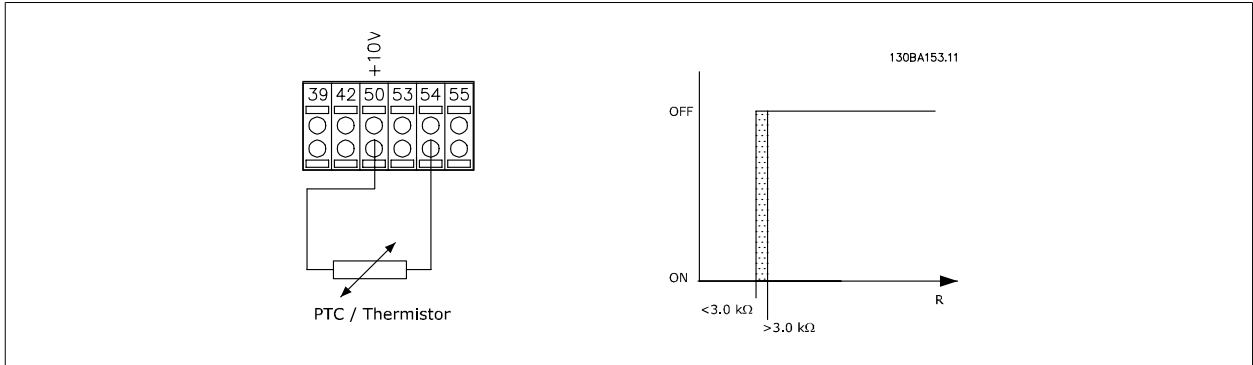

Input	Supply Voltage	Threshold
Digital/analog	Volt	Cut-out Values
Digital	24 V	<math>< 6.6\text{ k}\Omega - > 10.8\text{ k}\Omega</math>
Digital	10 V	<math>< 800\ \Omega - > 2.7\text{ k}\Omega</math>
Analog	10 V	<math>< 3.0\text{ k}\Omega - > 3.0\text{ k}\Omega</math>

**NOTE!**  
Ensure that the chosen supply voltage follows the specification of the thermistor element utilized.

Select *ETR Warning 1-4*, to activate a warning on the display when the motor is overloaded.

Select *ETR Trip 1-4* to trip the adjustable frequency drive when the motor is overloaded.

Program a warning signal via one of the digital outputs. The signal appears in the event of a warning and if the adjustable frequency drive trips (thermal warning).

ETR (Electronic Terminal Relay) functions 1-4 will calculate the load when the set-up where they were selected is active. For example, ETR starts calculating when set-up 3 is selected. For the North American market: The ETR functions provide class 20 motor overload protection in accordance with NEC.

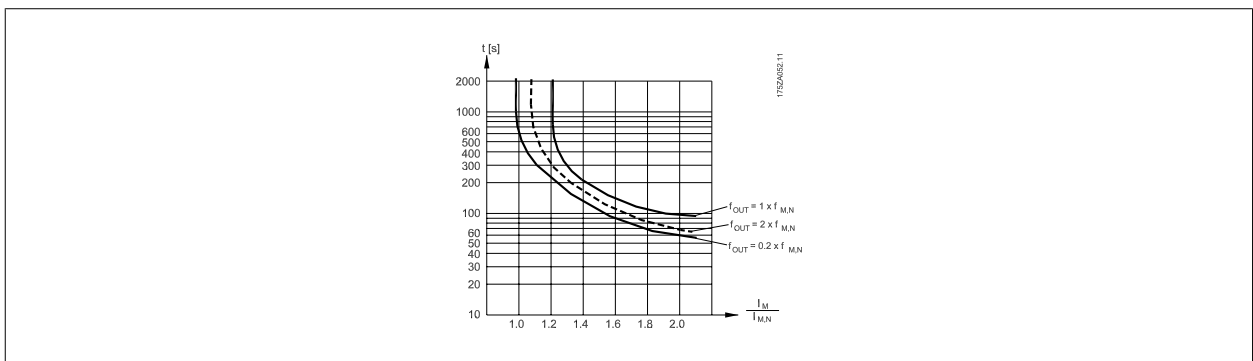

### 1-93 Thermistor Source

**Option:**
**Function:**

Select the input to which the thermistor (PTC sensor) should be connected. An analog input option [1] or [2] cannot be selected if the analog input is already in use as a reference source (selected in par. 3-15 *Reference 1 Source*, par. 3-16 *Reference 2 Source* or par. 3-17 *Reference 3 Source*). When using the MCB112, choice [0] *None* must always be selected.

[0] *	None
[1]	Analog input 53
[2]	Analog input 54
[3]	Digital input 18
[4]	Digital input 19
[5]	Digital input 32
[6]	Digital input 33

**NOTE!**

This parameter cannot be adjusted while the motor is running.

**NOTE!**

Digital inputs should be set to "No operation" - see par. 5-1\*.

### 2-10 Brake Function

**Option:**
**Function:**

[0] *	Off	No brake resistor is installed.
[1]	Resistor brake	A brake resistor is incorporated in the system, for dissipating surplus brake energy as heat. Connecting a brake resistor allows a higher DC link voltage during braking (generating operation). The resistor brake function is only active in adjustable frequency drives with an integral dynamic brake.
[2]	AC brake	Is selected to improve braking without using a brake resistor. This parameter controls an overmagnetization of the motor when running with a generative load. This function can improve the OVC function. Increasing the electrical losses in the motor allows the OVC function to increase the braking torque without exceeding the overvoltage limit. Please note that AC brake is not as effective as dynamic braking with resistor. AC brake is for VVC <sup>+</sup> and flux mode in both open-loop and closed-loop.

### 2-11 Brake Resistor (ohm)

**Range:**
**Function:**

50. Ohm*	[5. - 32000. Ohm]	Set the brake resistor value in Ohms. This value is used for monitoring the power to the brake resistor in par. 2-13 <i>Brake Power Monitoring</i> . This parameter is only active in adjustable frequency drives with an integral dynamic brake. If the selection is xxxx, use this parameter. If the selection is xxx.xx, use par. 3-81 <i>Quick Stop Ramp Time</i> .
----------	-------------------	--

### 2-12 Brake Power Limit (kW)

**Range:**
**Function:**

5.000 kW*	[0.001 - 500.000 kW]	Set the monitoring limit of the braking energy transmitted to the resistor.
-----------	----------------------	---

The monitoring limit is a product of the maximum duty cycle (120 sec.) and the maximum power of the brake resistor at that duty cycle. See the formula below.

For 200-240 V units:	$P_{resistor} = \frac{390^2 \times dutytime}{R \times 120}$
For 380-480 V units	$P_{resistor} = \frac{778^2 \times dutytime}{R \times 120}$
For 380-500 V units	$P_{resistor} = \frac{810^2 \times dutytime}{R \times 120}$
For 575-600 V units	$P_{resistor} = \frac{943^2 \times dutytime}{R \times 120}$

This parameter is only active in adjustable frequency drives with an integral dynamic brake.

### 2-13 Brake Power Monitoring

Option:	Function:
[0] * Off	No braking energy monitoring required.
[1] Warning	Activates a warning on the display when the power transmitted over 120 s exceeds 100% of the monitoring limit (par.2-12 <i>Brake Power Limit (kW)</i> ). The warning disappears when the transmitted power falls below 80% of the monitoring limit.
[2] Trip	Trips adjustable frequency drive and displays an alarm when the calculated power exceeds 100% of the monitoring limit.
[3] Warning and trip	

If power monitoring is set to *Off*[0] or *Warning* [1], the brake function remains active, even if the monitoring limit is exceeded. This may lead to thermal overload of the resistor. It is also possible to generate a warning via a relay/digital output. The measuring accuracy of the power monitoring depends on the accuracy of the resistance of the resistor (better than ± 20%).

### 2-15 Brake Check

Option:	Function:
[0] * Off	<p>Select type of test and monitoring function to check the connection to the brake resistor, or whether a brake resistor is present, and then display a warning or an alarm in the event of a fault.</p> <div style="border: 1px solid black; padding: 5px; margin: 10px 0;">  <p><b>NOTE!</b> The brake resistor disconnection function is tested during power-up. However, the brake IGBT test is performed when there is no braking. A warning or trip disconnects the brake function.</p> </div> <p>The testing sequence is as follows:</p> <ol style="list-style-type: none"> <li>The DC link ripple amplitude is measured for 300 ms without braking.</li> <li>The DC link ripple amplitude is measured for 300 ms with the brake turned on.</li> <li>If the DC link ripple amplitude while braking is lower than the DC link ripple amplitude before braking + 1%: <i>Brake check has failed and will return a warning or alarm.</i></li> <li>If the DC link ripple amplitude while braking is higher than the DC link ripple amplitude before braking + 1%: <i>Brake check is OK.</i></li> </ol>

[0] \* Off Monitors brake resistor and brake IGBT for a short-circuit during operation. If a short-circuit occurs, warning 25 appears.

[1]	Warning	Monitors brake resistor and brake IGBT for a short-circuit, and runs a test for brake resistor disconnection during power-up.
[2]	Trip	Monitors for a short-circuit or disconnection of the brake resistor, or a short-circuit of the brake IGBT. If a fault occurs, the adjustable frequency drive cuts out while displaying an alarm (trip locked).
[3]	Stop and trip	Monitors for a short-circuit or disconnection of the brake resistor, or a short-circuit of the brake IGBT. If a fault occurs, the adjustable frequency drive ramps down to coast and then trips. A trip lock alarm is displayed (e.g., warning 25, 27 or 28).
[4]	AC brake	Monitors for a short-circuit or disconnection of the brake resistor, or a short-circuit of the brake IGBT. If a fault occurs, the adjustable frequency drive performs a controlled ramp-down. This option is only available for the FC 302.
[5]	Trip Lock	

**NOTE!**

NB!: Remove a warning arising in connection with *Off*[0] or *Warning* [1] by cycling the line power supply. The fault must be corrected first. For *Off*[0] or *Warning* [1], the adjustable frequency drive keeps running even if a fault is located.

This parameter is only active in adjustable frequency drives with an integral dynamic brake.

### 4.3.1 2-2\* Mechanical Brake

Parameters for controlling operation of an electro-magnetic (mechanical) brake, typically required in hoisting applications.

To control a mechanical brake, a relay output (relay 01 or relay 02) or a programmed digital output (terminal 27 or 29) is required. Normally, this output must be closed during periods when the adjustable frequency drive is unable to 'hold' the motor, e.g., due to an excessive load. Select *Mechanical Brake Control* [32] for applications with an electro-magnetic brake in par.5-40 *Function Relay*, par. 5-30 *Terminal 27 Digital Output*, or par. 5-31 *Terminal 29 Digital Output*. When selecting *Mechanical brake control* [32], the mechanical brake is closed from start up until the output current is above the level selected in par.2-20 *Release Brake Current*. During stop, the mechanical brake activates when the speed falls below the level specified in par.2-21 *Activate Brake Speed [RPM]*. If the adjustable frequency drive enters an alarm condition or an overcurrent or overvoltage situation, the mechanical brake immediately cuts in. This is also the case during safe stop.

**NOTE!**

Protection mode and trip delay features (par. 14-25 *Trip Delay at Torque Limit* and par. 14-26 *Trip Delay at Inverter Fault*) may delay the activation of the mechanical brake in an alarm condition. These features must be disabled in hoisting applications.

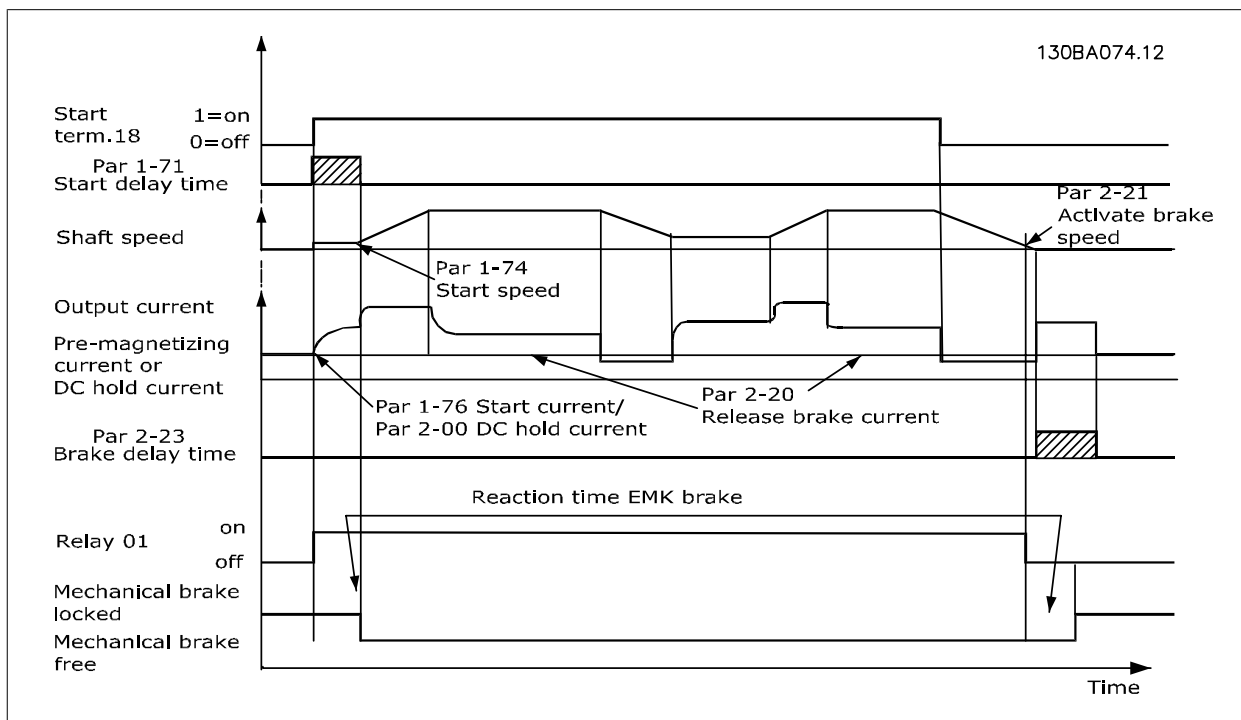

**2-20 Release Brake Current**

**Range:**

par. 16-37 [0.00 - par. 16-37 A]  
A\*

**Function:**

Set the motor current for release of the mechanical brake when a start condition is present. The upper limit is specified in par. 16-37 *Inv. Max. Current*.

**2-21 Activate Brake Speed [RPM]**

**Range:**

0 RPM\* [0 - 30000 RPM]

**Function:**

Set the motor speed for activation of the mechanical brake when a stop condition is present. The upper speed limit is specified in par. 4-53 *Warning Speed High*.

**2-22 Activate Brake Speed [Hz]**

**Range:**

0 Hz\* [0.0 - 5000.0 Hz]

**Function:**

Set the motor frequency for activation of the mechanical brake when a stop condition is present.

**2-23 Activate Brake Delay**

**Range:**

0.0 s\* [0.0 - 5.0 s]

**Function:**

Enter the brake delay time of the coast after ramp-down time. The shaft is held at zero speed with full holding torque. Ensure that the mechanical brake has locked the load before the motor enters coast mode. See *Mechanical Brake Control* section in the Design Guide.

**2-24 Stop Delay**

**Range:**

0.0 s\* [0.0 - 5.0 s]

**Function:**

Set the time interval from the moment when the motor is stopped until the brake closes. This parameter is a part of the stopping function.

**2-25 Brake Release Time**

**Range:**

0.20 s\* [0.00 - 5.00 s]

**Function:**

This value defines the time it takes for the mechanical brake to open/close. This parameter must act as a timeout when brake feedback is activated.

**2-26 Torque Ref**

**Range:**

0.00 %\* [0 - 0 %]

**Function:**

The value defines the torque applied against the closed mechanical brake before release

**2-27 Torque Ramp Time**

**Range:**

0.2 s\* [0.0 - 5.0 s]

**Function:**

The value defines the duration of the torque ramp in clockwise direction.

**2-28 Gain Boost Factor**

**Range:**

1.00 N/A\* [1.00 - 4.00 N/A]

**Function:**

Only active in flux closed-loop. The function ensures a smooth transition from torque control mode to speed control mode when the motor takes over the load from the brake.

4

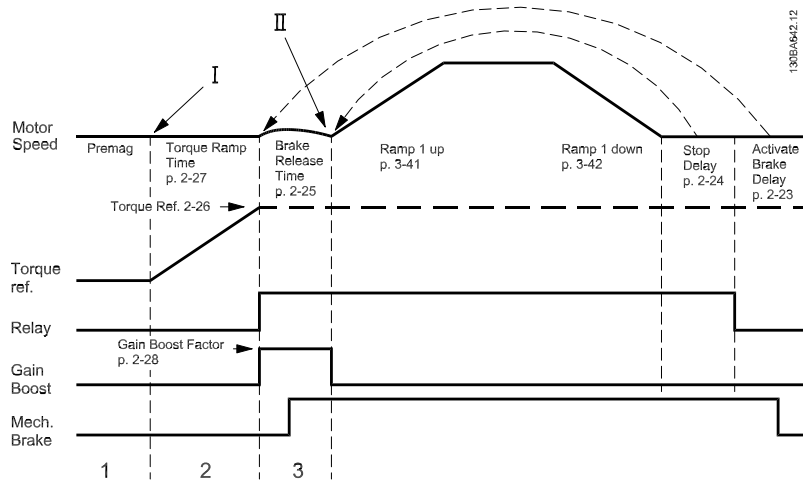

Figure 4.1: Brake release sequence for hoist mechanical brake control

I) *Activate brake delay*: The adjustable frequency drive starts again from the *mechanical brake engaged* position.

II) *Stop delay*: When the time between successive starts is shorter than the setting in par.2-24 *Stop Delay*, the adjustable frequency drive starts without applying the mechanical brake (e.g., reversing).

**3-10 Preset Reference**

Array [8]  
Range: 0-7

**Range:**

0.00 %\* [-100.00 - 100.00 %]

**Function:**

Enter up to eight different preset references (0-7) in this parameter using array programming. The preset reference is stated as a percentage of the value Ref<sub>MAX</sub> (par.3-03 *Maximum Reference*). If a Ref<sub>MIN</sub> different from 0 (par.3-02 *Minimum Reference*) is programmed, the preset reference is calculated as a percentage of the full reference range, i.e., on the basis of the difference between Ref<sub>MAX</sub> and Ref<sub>MIN</sub>. Afterwards, the value is added to Ref<sub>MIN</sub>. When using preset references, select Preset ref. bit 0 / 1 / 2 [16], [17] or [18] for the corresponding digital inputs in parameter group 5.1\*.

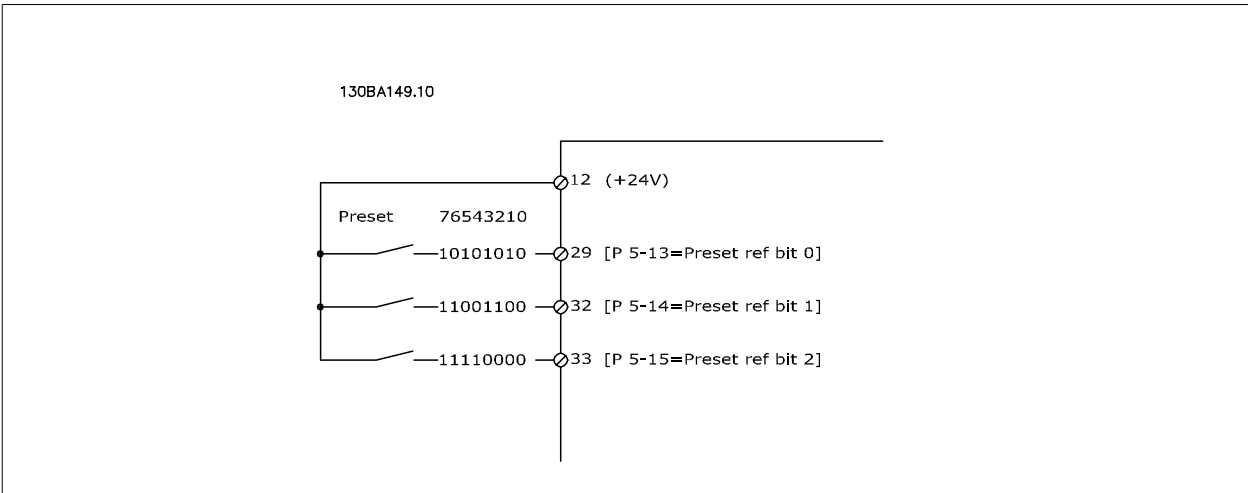

Preset ref. bit	2	1	0
Preset ref. 0	0	0	0
Preset ref. 1	0	0	1
Preset ref. 2	0	1	0
Preset ref. 3	0	1	1
Preset ref. 4	1	0	0
Preset ref. 5	1	0	1
Preset ref. 6	1	1	0
Preset ref. 7	1	1	1

**3-11 Jog Speed [Hz]**

**Range:**

0 Hz\* [0.0 - par. 4-14 Hz]

**Function:**

The jog speed is a fixed output speed at which the adjustable frequency drive is running when the jog function is activated.  
See also par. 3-80 *Jog Ramp Time*.

**3-15 Reference Source 1**

**Option:**

- [0] No function
- [1] \* Analog input 53
- [2] Analog input 54

**Function:**

Select the reference input to be used for the first reference signal. Par. 3-15, 3-16 and 3-17 define up to three different reference signals. The sum of these reference signals defines the actual reference.

[7] Frequency input 29 (FC 302 only)

[8] Frequency input 33

[11] Local bus reference

[20] Digital potentiometer

[21] Analog input X30-11

[22] Analog input X30-12

### 3-16 Reference Resource 2

**Option:**
**Function:**

Select the reference input to be used for the second reference signal. par. 3-15 *Reference Resource 1*, par.3-16 *Reference Resource 2* and par.3-17 *Reference Resource 3* define up to three different reference signals. The sum of these reference signals defines the actual reference.

[0] No function

[1] Analog input 53

[2] Analog input 54

[7] Frequency input 29

[8] Frequency input 33

[11] Local bus reference

[20] \* Digital pot.meter

[21] Analog input X30-11

[22] Analog input X30-12

### 3-17 Reference Resource 3

**Option:**
**Function:**

Select the reference input to be used for the third reference signal. par. 3-15 *Reference Resource 1*, par.3-16 *Reference Resource 2* and par.3-17 *Reference Resource 3* define up to three different reference signals. The sum of these reference signals defines the actual reference.

[0] No function

[1] Analog input 53

[2] Analog input 54

[7] Frequency input 29

[8] Frequency input 33

[11] \* Local bus reference

[20] Digital pot.meter

[21] Analog input X30-11

[22] Analog input X30-12

### 5-00 Digital I/O Mode

**Option:**
**Function:**

Digital inputs and programmed digital outputs are pre-programmable for operation either in PNP or NPN systems.

[0] \* PNP Action on positive directional pulses (↑). PNP systems are pulled down to GND.

[1] NPN Action on negative directional pulses (↓). NPN systems are pulled up to + 24 V, internally in the adjustable frequency drive.



**NOTE!**  
Once this parameter has been changed, it must be activated by performing a power cycle.

This parameter cannot be adjusted while the motor is running.

**5-01 Terminal 27 Mode**

Option:	Function:
[0] * Input	Defines terminal 27 as a digital input.
[1] Output	Defines terminal 27 as a digital output.

Please note that this parameter cannot be adjusted while the motor is running.

**5-02 Terminal 29 Mode**

Option:	Function:
[0] * Input	Defines terminal 29 as a digital input.
[1] Output	Defines terminal 29 as a digital output.

This parameter is available for the FC 302 only.

This parameter cannot be adjusted while the motor is running.

### 4.3.2 5-1\* Digital Inputs

Parameters for configuring the input functions for the input terminals.

The digital inputs are used for selecting various functions in the adjustable frequency drive. All digital inputs can be set to the following functions:

Digital input function	Select	Terminal
No operation	[0]	All *term 32, 33
Reset	[1]	All
Coast inverse	[2]	All *term 27
Coast and reset inverse	[3]	All
Quick stop inverse	[4]	All
DC brake inverse	[5]	All
Stop inverse	[6]	All
Start	[8]	All *term 18
Latched start	[9]	All
Reversing	[10]	All *term 19
Start reversing	[11]	All
Enable start forward	[12]	All
Enable start reverse	[13]	All
Jog	[14]	All *term 29
Preset reference on	[15]	All
Preset ref bit 0	[16]	All
Preset ref bit 1	[17]	All
Preset ref bit 2	[18]	All
Freeze reference	[19]	All
Freeze output	[20]	All
Speed up	[21]	All
Slow	[22]	All
Set-up select bit 0	[23]	All
Set-up select bit 1	[24]	All
Precise stop inverse	[26]	18, 19
Precise start, stop	[27]	18, 19
Catch up	[28]	All
Slow-down	[29]	All
Counter input	[30]	29, 33
Pulse input	[32]	29, 33
Ramp bit 0	[34]	All
Ramp bit 1	[35]	All
Line failure inverse	[36]	All
Latched precise start	[40]	18, 19

Latched precise stop inverse	[41]	18, 19
DigiPot Increase	[55]	All
DigiPot Decrease	[56]	All
DigiPot Clear	[57]	All
Counter A (up)	[60]	29, 33
Counter A (down)	[61]	29, 33
Reset Counter A	[62]	All
Counter B (up)	[63]	29, 33
Counter B (down)	[64]	29, 33
Reset Counter B	[65]	All
Mech. Brake Feedb.	[70]	All
Mech. Brake Feedb. Inv.	[71]	All
PTC Card 1	[80]	All

4

FC 300 standard terminals are 18, 19, 27, 29, 32 and 33. MCB 101 terminals are X30/2, X30/3 and X30/4.

Terminal 29 functions as an output only in the FC 302.

Functions dedicated to only one digital input are stated in the associated parameter.

All digital inputs can be programmed to these functions:

[0]	No operation	No reaction to signals transmitted to the terminal.
[1]	Reset	Resets adjustable frequency drive after a TRIP/ALARM. Not all alarms can be reset.
[2]	Coast inverse	(Default Digital input 27): Coasting stop, inverted input (NC). The adjustable frequency drive leaves the motor in free mode. Logic '0' => coasting stop.
[3]	Coast and reset inverse	Reset and coasting stop Inverted input (NC). Leaves the motor in free mode and resets the adjustable frequency drive. Logic '0' => coasting stop and reset.
[4]	Quick stop inverse	Inverted input (NC). Generates a stop in accordance with the quick-stop ramp time set in par. 3-81 <i>Quick Stop Ramp Time</i> . When motor stops, the shaft is in free mode. Logic '0' => quick stop.
[5]	DC brake inverse	Inverted input for DC braking (NC). Stops motor by energizing it with a DC current for a certain time period. See par. 2-01 <i>DC Brake Current</i> to par. 2-03 <i>DC Brake Cut In Speed [RPM]</i> . The function is only active when the value in par. 2-02 <i>DC Braking Time</i> is different from 0. Logic "0" => DC braking.
[6]	Stop inverse	Stop Inverted function. Generates a stop function when the selected terminal goes from logical level '1' to '0'. The stop is performed according to the selected ramp time (par. 3-42 <i>Ramp 1 Ramp Down Time</i> , par. 3-52 <i>Ramp 2 Ramp down Time</i> , par. 3-62 <i>Ramp 3 Ramp down Time</i> , par. 3-72 <i>Ramp 4 Ramp Down Time</i> ).
<div style="border: 1px solid black; padding: 5px;">  <p><b>NOTE!</b> When the adjustable frequency drive is at the torque limit and has received a stop command, it may not stop by itself. To ensure that the adjustable frequency drive stops, configure a digital output to <i>Torque limit &amp; stop</i> [27] and connect this digital output to a digital input that is configured as coast.</p> </div>		
[8]	Start	(Default Digital input 18): Select start for a start/stop command. Logic '1' = start, logic '0' = stop.
[9]	Latched start	The motor starts if a pulse is applied for a minimum of 2 ms. The motor stops when stop inverse is activated.
[10]	Reversing	(Default Digital input 19). Change the direction of motor shaft rotation. Select Logic '1' to reverse. The reversing signal only changes the direction of rotation. It does not activate the start function. Select both directions in par. 4-10 <i>Motor Speed Direction</i> . The function is not active in process closed-loop.
[11]	Start reversing	Used for start/stop and for reversing on the same wire. Signals on start are not allowed at the same time.
[12]	Enable start forward	Disengages the counter-clockwise movement and allows for the clockwise direction.
[13]	Enable start reverse	Disengages the clockwise movement and allows for the counter-clockwise direction.
[14]	Jog	(Default Digital input 29): Use to activate jog speed. See par.3-11 <i>Jog Speed [Hz]</i> .

[15]	Preset reference on	Shifts between external reference and preset reference. It is assumed that <i>External/preset</i> [1] has been selected in par. 3-04 <i>Reference Function</i> . Logic '0' = external reference active; logic '1' = one of the eight preset references is active.
[16]	Preset ref bit 0	Preset ref. bit 0, 1, and 2 enables a choice between one of the eight preset references according to the table below.
[17]	Preset ref bit 1	Same as Preset ref bit 0 [16].
[18]	Preset ref bit 2	Same as Preset ref bit 0 [16].

Preset ref. bit	2	1	0
Preset ref. 0	0	0	0
Preset ref. 1	0	0	1
Preset ref. 2	0	1	0
Preset ref. 3	0	1	1
Preset ref. 4	1	0	0
Preset ref. 5	1	0	1
Preset ref. 6	1	1	0
Preset ref. 7	1	1	1

[19]	Freeze ref.	Freezes the actual reference, which is now the point of enable/condition for Speed up and Slow to be used. If speed up/down is used, the speed change always follows ramp 2 (par. 3-51 <i>Ramp 2 Ramp up Time</i> and par. 3-52 <i>Ramp 2 Ramp down Time</i> ) in the range 0 - par.3-03 <i>Maximum Reference</i> .
------	-------------	---

[20]	Freeze output	Freezes the actual motor frequency (Hz), which is now the point of enable/condition for Speed up and Slow to be used. If speed up/down is used, the speed change always follows ramp 2 (par. 3-51 <i>Ramp 2 Ramp up Time</i> and par. 3-52 <i>Ramp 2 Ramp down Time</i> ) in the range 0 - par. 1-23 <i>Motor Frequency</i> .
------	---------------	---

**NOTE!**  
When freeze output is active, the adjustable frequency drive cannot be stopped via a low 'start [8]' signal. Stop the adjustable frequency drive via a terminal programmed for Coast inverse [2] or Coast and reset inv.

[21]	Speed up	Select Speed up/down if digital control of the up/down speed is desired (motor potentiometer). Activate this function by selecting either Freeze reference or Freeze output. When Speed up/down is activated for less than 400 msec, the resulting reference will be increased/decreased by 0.1%. If Speed up/down is activated for more than 400 msec, the resulting reference will follow the setting in ramping up/down parameter 3-x1/ 3-x2.
------	----------	--

	Shut down	Catch up
Unchanged speed	0	0
Reduced by %-value	1	0
Increased by %-value	0	1
Reduced by %-value	1	1

[22]	Slow	Same as Speed up [21].
[23]	Set-up select bit 0	Select Set-up select bit 0 or 1 to select one of the four set-ups. Set par. 0-10 <i>Active Set-up</i> to Multi Set-up.
[24]	Set-up select bit 1	(Default Digital input 32): Same as Set-up select bit 0 [23].
[26]	Precise stop inv.	Prolongs stop signal to give a precise stop independent of speed. Sends an inverted stop signal when the precise stop function is activated in par. 1-83 <i>Precise Stop Function</i> . Precise stop inverse function is available for terminals 18 or 19.
[27]	Precise start, stop	Use when Precise ramp stop [0] is selected in par 1-83.

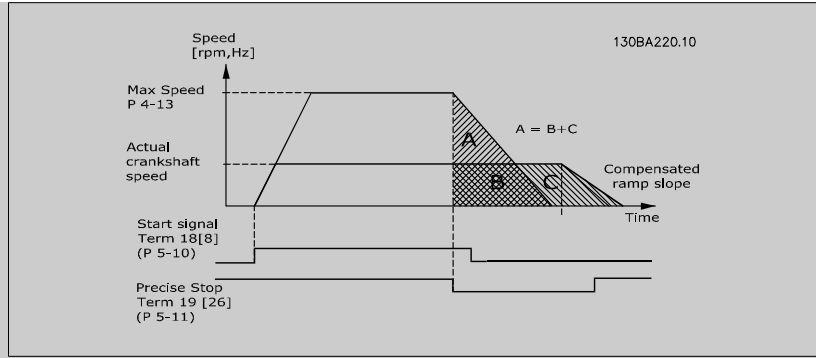

4

[28]	Catch up	Increases reference value by percentage (relative) set in par. 3-12 <i>Catch up/slow Down Value</i> .
[29]	Slow-down	Reduces reference value by percentage (relative) set in par. 3-12 <i>Catch up/slow Down Value</i> .
[30]	Counter input	Precise stop function in par. 1-83 <i>Precise Stop Function</i> acts as counter stop or speed compensated counter stop with or without reset. The counter value must be set in par. 1-84 <i>Precise Stop Counter Value</i> .
[32]	Pulse input	Use pulse sequence as either reference or feedback. Scaling is done in par. group 5-5*.
[34]	Ramp bit 0	Enables a choice between one of the four ramps available, according to the table below.
[35]	Ramp bit 1	Same as Ramp bit 0.

Preset ramp bit	1	0
Ramp 1	0	0
Ramp 2	0	1
Ramp 3	1	0
Ramp 4	1	1

[36]	Line failure inverse	Activates par. 14-10 <i>Mains Failure</i> . Line failure inverse is active in the logic "0" situation.
[41]	Latched Precise Stop inverse	Sends a latched stop signal when the precise stop function is activated in par. 1-83 <i>Precise Stop Function</i> . The latched precise stop inverse function is available for terminals 18 or 19.
[55]	DigiPot Increase	INCREASE signal to the digital potentiometer function described in parameter group 3-9*.
[56]	DigiPot Decrease	DECREASE signal to the digital potentiometer function described in parameter group 3-9*.
[57]	DigiPot Clear	Clears the digital potentiometer reference described in parameter group 3-9*.
[60]	Counter A	(Terminal 29 or 33 only) Input for increment counting in the SLC counter.
[61]	Counter A	(Terminal 29 or 33 only) Input for decrement counting in the SLC counter.
[62]	Reset Counter A	Input for reset of counter A.
[63]	Counter B	(Terminal 29 or 33 only) Input for increment counting in the SLC counter.
[64]	Counter B	(Terminal 29 or 33 only) Input for decrement counting in the SLC counter.
[65]	Reset Counter B	Input for reset of counter B.
[70]	Mech. Brake Feedback	Brake feedback for hoisting applications
[71]	Mech. Brake Feedback inv.	Inverted brake feedback for hoisting applications
[80]	PTC Card 1	All digital inputs can be set to PTC card 1 [80]. However, only one digital input must be set to this choice.

### 4.3.3 5-3\* Digital Outputs

Parameters for configuring the output functions for the output terminals. The two solid state digital outputs are common for terminals 27 and 29. Set the I/O function for terminal 27 in par.5-01 *Terminal 27 Mode*, and set the I/O function for terminal 29 in par. 5-02 *Terminal 29 Mode*. These parameters cannot be adjusted while the motor is running.

[0]	No operation	<i>Default for all digital outputs and relay outputs</i>
[1]	Control ready	The control board receives supply voltage.
[2]	Drive ready	The adjustable frequency drive is ready for operation and applies a supply signal to the control board.
[3]	Drive ready/remote control	The adjustable frequency drive is ready for operation and is in Auto On mode.
[4]	Enable/no warning	Ready for operation. No start or stop command has been given (start/disable). There are no warnings.
[5]	VLT running	Motor is running.
[6]	Running/no warning	Output speed is higher than the speed set in par. 1-81 <i>Min Speed for Function at Stop [RPM]</i> . The motor is running and there are no warnings.
[7]	Run in range/no warning	Motor is running within the programmed current and speed ranges set in par. 4-50 <i>Warning Current Low</i> to par. 4-53 <i>Warning Speed High</i> . There are no warnings.
[8]	Run on reference/no warning	Motor runs at reference speed.
[9]	Alarm	An alarm activates the output. There are no warnings.
[10]	Alarm or warning	An alarm or a warning activates the output.
[11]	At torque limit	The torque limit set in par. 4-16 <i>Torque Limit Motor Mode</i> or par. 1-17 has been exceeded.
[12]	Out of current range	The motor current is outside the range set in par. 4-18 <i>Current Limit</i> .
[13]	Below current, low	Motor current is lower than set in par. 4-50 <i>Warning Current Low</i> .
[14]	Above current, high	Motor current is higher than set in par. 4-51 <i>Warning Current High</i> .
[15]	Out of speed range	Output frequency is outside the frequency ranges set in par. 4-50 <i>Warning Current Low</i> and par. 4-51 <i>Warning Current High</i> .
[16]	Below speed, low	Output speed is lower than the setting in par. 4-52 <i>Warning Speed Low</i> .
[17]	Above speed, high	Output speed is higher than the setting in par. 4-53 <i>Warning Speed High</i> .
[18]	Out of feedback range	Feedback is outside the range set in par. 4-56 <i>Warning Feedback Low</i> and par. 4-57 <i>Warning Feedback High</i> .
[19]	Below feedback, low	Feedback is below the limit set in par. 4-56 <i>Warning Feedback Low</i> .
[20]	Above feedback, high	Feedback is above the limit set in par. 4-57 <i>Warning Feedback High</i> .
[21]	Thermal warning	The thermal warning turns on when the temperature exceeds the limit in the motor, the adjustable frequency drive, the brake resistor or the thermistor.
[22]	Ready, no thermal warning	The adjustable frequency drive is ready for operation and there is no overtemperature warning.
[23]	Remote, ready, no thermal warning	The adjustable frequency drive is ready for operation and is in auto on mode. There is no overtemperature warning.
[24]	Ready, no over/undervoltage	The adjustable frequency drive is ready for operation, and the AC line voltage is within the specified voltage range (see <i>General Specifications</i> section).
[25]	Reverse	<i>Reversing. Logic '1'</i> when CW rotation of the motor. Logic '0' when CCW rotation of the motor. If the motor is not rotating, the output will follow the reference.
[26]	Bus OK	Active communication (no timeout) via the serial communication port.
[27]	Torque limit and stop	Used in performing a coasting stop and in torque limit condition. If the adjustable frequency drive has received a stop signal and is at the torque limit, the signal is logic "0."
[28]	Brake, no brake warning	Brake is active and there are no warnings.

[29]	Brake ready, no fault	Brake is ready for operation and there are no faults.
[30]	Brake fault (IGBT)	Output is Logic '1' when the brake IGBT is short-circuited. Use this function to protect the adjustable frequency drive if there is a fault on the brake modules. Use the output/relay to cut out the AC line voltage from the adjustable frequency drive.
[31]	Relay 123	The relay is activated when Control Word [0] is selected in parameter group 8-**.
[32]	Mechanical brake control	Enables control of an external mechanical brake; see description in the section <i>Control of Mechanical Brake</i> , and par. group 2-2*.
[33]	Safe stop activated (FC 302 only)	Indicates that the safe stop on terminal 37 has been activated.
[40]	Out of ref range	
[41]	Below reference, low	
[42]	Above reference, high	
[45]	Bus Ctrl	Controls output via bus. The state of the output is set in par. 5-90 <i>Digital &amp; Relay Bus Control</i> . The output state is retained in the event of bus timeout.
[46]	Bus Ctrl On at timeout	Controls output via bus. The state of the output is set in par. 5-90 <i>Digital &amp; Relay Bus Control</i> . In the event of a bus timeout, the output state is set high (On).
[47]	Bus Ctrl Off at timeout	Controls output via bus. The state of the output is set in par. 5-90 <i>Digital &amp; Relay Bus Control</i> . In the event of a bus timeout, the output state is set low (Off).
[51]	MCO controlled	
[55]	Pulse output	
[60]	Comparator 0	See par. group 13-1*. If Comparator 0 is evaluated as TRUE, the output will be high. Otherwise, it will be low.
[61]	Comparator 1	See par. group 13-1*. If Comparator 1 is evaluated as TRUE, the output will be high. Otherwise, it will be low.
[62]	Comparator 2	See par. group 13-1*. If Comparator 2 is evaluated as TRUE, the output will be high. Otherwise, it will be low.
[63]	Comparator 3	See par. group 13-1*. If Comparator 3 is evaluated as TRUE, the output will be high. Otherwise, it will be low.
[64]	Comparator 4	See par. group 13-1*. If Comparator 4 is evaluated as TRUE, the output will be high. Otherwise, it will be low.
[65]	Comparator 5	See par. group 13-1*. If Comparator 5 is evaluated as TRUE, the output will be high. Otherwise, it will be low.
[70]	Logic Rule 0	See par. group 13-4*. If logic rule 0 is evaluated as TRUE, the output will be high. Otherwise, it will be low.
[71]	Logic Rule 1	See par. group 13-4*. If logic rule 1 is evaluated as TRUE, the output will be high. Otherwise, it will be low.
[72]	Logic Rule 2	See par. group 13-4*. If logic rule 2 is evaluated as TRUE, the output will be high. Otherwise, it will be low.
[73]	Logic Rule 3	See par. group 13-4*. If logic rule 3 is evaluated as TRUE, the output will be high. Otherwise, it will be low.
[74]	Logic Rule 4	See par. group 13-4*. If logic rule 4 is evaluated as TRUE, the output will be high. Otherwise, it will be low.
[75]	Logic Rule 5	See par. group 13-4*. If logic rule 5 is evaluated as TRUE, the output will be high. Otherwise, it will be low.
[80]	SL Digital Output A	See par. 13-52 <i>SL Controller Action</i> . The output will go high whenever the Smart Logic Action [38] <i>Set dig. out. A high</i> is executed. The output will go low whenever the Smart Logic Action [32] <i>Set dig. out. A low</i> is executed.

[81]	SL Digital Output B	See par. 13-52 <i>SL Controller Action</i> . The input will go high whenever the Smart Logic Action [39] <i>Set dig. out. A high</i> is executed. The input will go low whenever the Smart Logic Action [33] <i>Set dig. out. A low</i> is executed.
[82]	SL Digital Output C	See par. 13-52 <i>SL Controller Action</i> . The input will go high whenever the Smart Logic Action [40] <i>Set dig. out. A high</i> is executed. The input will go low whenever the Smart Logic Action [34] <i>Set dig. out. A low</i> is executed.
[83]	SL Digital Output D	See par. 13-52 <i>SL Controller Action</i> . The input will go high whenever the Smart Logic Action [41] <i>Set dig. out. A high</i> is executed. The input will go low whenever the Smart Logic Action [35] <i>Set dig. out. A low</i> is executed.
[84]	SL Digital Output E	See par. 13-52 <i>SL Controller Action</i> . The input will go high whenever the Smart Logic Action [42] <i>Set dig. out. A high</i> is executed. The input will go low whenever the Smart Logic Action [36] <i>Set dig. out. A low</i> is executed.
[85]	SL Digital Output F	See par. 13-52 <i>SL Controller Action</i> . The input will go high whenever the Smart Logic Action [43] <i>Set dig. out. A high</i> is executed. The input will go low whenever the Smart Logic Action [37] <i>Set dig. out. A low</i> is executed.
[120]	Local reference active	Output is high when par. 3-13 <i>Reference Site</i> = [2] Local or when par. 3-13 <i>Reference Site</i> = [0] <i>Linked to hand auto</i> at the same time as the LCP is in hand on mode.
[121]	Remote reference active	Output is high when par. 3-13 <i>Reference Site</i> = Remote [1] or <i>Linked to hand/auto</i> [0] while the LCP is in [Auto on] mode.
[122]	No alarm	Output is high when no alarm is present.
[123]	Start cmd. active	Output is high when there is an active start command (i.e., via digital input bus connection or [Hand on] or [Auto on]), and no stop or start command is active.
[124]	Running reverse	Output is high when the adjustable frequency drive is running counter clockwise (the logical product of the status bits 'running' AND 'reverse').
[125]	Drive in hand mode	Output is high when the adjustable frequency drive is in hand on mode (as indicated by the LED light above [Hand on]).
[126]	Drive in auto mode	Output is high when the adjustable frequency drive is in hand on mode (as indicated by the LED light above [Auto on]).

**5-40 Function Relay**

Array [9]

(Relay 1 [0], Relay 2 [1], Relay 3 [2], Relay 4 [3], Relay 5 [4], Relay 6 [5], Relay 6 [5], Relay 7 [6], Relay 8 [7], Relay 9 [8])

**Option:**

**Function:**

[0] *	No operation
[1]	Control ready
[2]	Drive ready
[3]	Drive rdy/rem ctrl
[4]	Enable / no warning
[5]	VLT running
[6]	Running / no warning
[7]	Run in range/no warn
[8]	Run on ref/no warn
[9]	Alarm
[10]	Alarm or warning
[11]	At torque limit
[12]	Out of current range
[13]	Below current, low

[14]	Above current, high
[15]	Out of speed range
[16]	Below speed, low
[17]	Above speed, high
[18]	Out of feedb. range
[19]	Below feedback, low
[20]	Above feedback, high
[21]	Thermal warning
[22]	Ready,no thermal W
[23]	Remote,ready,no TW
[24]	Ready, Voltage OK
[25]	Reverse
[26]	Bus OK
[27]	Torque limit & stop
[28]	Brake, no brake war
[29]	Brake ready, no fault
[30]	Brake fault (IGBT)
[31]	Relay 123
[32]	Mech brake ctrl
[33]	Safe stop active
[36]	Control word bit 11
[37]	Control word bit 12
[38]	Motor feedback error
[39]	Tracking error
[40]	Out of ref range
[41]	Below reference, low
[42]	Above ref, high
[43]	Extended PID Limit
[45]	Bus ctrl.
[46]	Bus ctrl, 1 if timeout
[47]	Bus ctrl, 0 if timeout
[51]	MCO controlled
[60]	Comparator 0
[61]	Comparator 1
[62]	Comparator 2
[63]	Comparator 3
[64]	Comparator 4
[65]	Comparator 5
[70]	Logic rule 0
[71]	Logic rule 1
[72]	Logic rule 2
[73]	Logic rule 3
[74]	Logic rule 4



[75]	Logic rule 5
[80]	SL digital output A
[81]	SL digital output B
[82]	SL digital output C
[83]	SL digital output D
[84]	SL digital output E
[85]	SL digital output F
[120]	Local ref active
[121]	Remote ref active
[122]	No alarm
[123]	Start command activ
[124]	Running reverse
[125]	Drive in hand mode
[126]	Drive in auto mode

**14-22 Operation Mode**

**Option:**

**Function:**

Use this parameter to specify normal operation, to perform tests, or to initialize all parameters except par. 15-03 *Power-ups*, par. 15-04 *Over Temps* and par. 15-05 *Over Volts*. This function is active only when the power is cycled to the adjustable frequency drive.

Select *Normal operation* [0] for normal operation of the adjustable frequency drive with the motor in the selected application.

Select *Control card test* [1] to test the analog and digital inputs and outputs and the +10 V control voltage. The test requires a test connector with internal connections. Use the following procedure for the control card test:

1. Select *Control card test* [1].
2. Disconnect the line power supply and wait for the light in the display to go out.
3. Set switches S201 (A53) and S202 (A54) = 'ON' / I.
4. Insert the test plug (see below).
5. Connect to the line power supply.
6. Carry out various tests.
7. The results are displayed on the LCP and the adjustable frequency drive moves into an infinite loop.
8. par.14-22 *Operation Mode* is automatically set to normal operation. Carry out a power cycle to start up in normal operation after a control card test.

**If the test is OK:**

LCP readout: Control Card OK.

Disconnect the line power supply and remove the test plug. The green LED on the control card will light up.

**If the test fails:**

LCP readout: Control Card I/O failure.

Replace the adjustable frequency drive or control card. The red LED on the control card is turned on. Test plugs (connect the following terminals to each other): 18 - 27 - 32; 19 - 29 - 33; 42 - 53 - 54

4

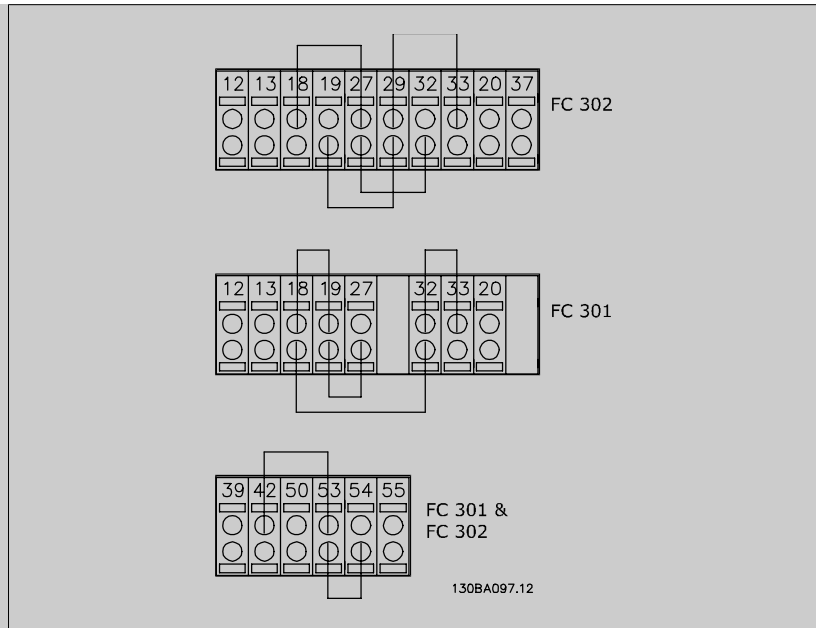

Select *Initialization* [2] to reset all parameter values to default settings, except for par. 15-03 *Power-ups*, par. 15-04 *Over Temps*, and par. 15-05 *Over Volts*. The adjustable frequency drive will reset during the next power-up.  
par.14-22 *Operation Mode* will also revert to the default setting *Normal operation* [0].

- [0] \* Normal operation
- [1] Control card test
- [2] Initialisation
- [3] Boot mode

14-50 RFI 1

**Option:**

- [0] Off

**Function:**

Select *Off* [0] only if the adjustable frequency drive is fed by an isolated line power source, i.e., from a special IT line power source.  
In this mode, the internal RFI filter capacitors between chassis and the line power RFI filter circuit are cut out to avoid damage to the intermediate circuit and to reduce the ground capacity currents according to IEC 61800-3.

- [1] \* On Select *On* [1] to ensure that the adjustable frequency drive complies with EMC standards.

15-43 Software Version

**Range:**

- 0 N/A\* [0 - 0 N/A]

**Function:**

View the combined SW version (or 'package version') consisting of power SW and control SW.

## 4.4 Parameter Lists

### Changes during operation

"TRUE" means that the parameter can be changed while the adjustable frequency drive is in operation, and "FALSE" means that it must be stopped before a change can be made.

### 4 Set-up

'All set-up': the parameters can be set individually in each of the four set-ups, i.e., one single parameter can have four different data values.

'1 set-up': the data value will be the same in all set-ups.

### Conversion index

This number refers to a conversion figure used when writing or reading to and from the adjustable frequency drive.

<b>Conv. index</b>	100	67	6	5	4	3	2	1	0	-1	-2	-3	-4	-5	-6
<b>Conv. factor</b>	1	1/60	1000000	100000	10000	1000	100	10	1	0.1	0.01	0.001	0.0001	0.00001	0.000001

Data type	Description	Type
2	Integer 8	Int8
3	Integer 16	Int16
4	Integer 32	Int32
5	Unsigned 8	UInt8
6	Unsigned 16	UInt16
7	Unsigned 32	UInt32
9	Visible String	VisStr
33	Normalized value 2 bytes	N2
35	Bit sequence of 16 Boolean variables	V2
54	Time difference w/o date	TimD

See the adjustable frequency drive *Design Guide* for further information about data types 33, 35 and 54.

Parameters for the adjustable frequency drive are grouped into various parameter groups for easy selection of the correct parameters for optimized operation of the adjustable frequency drive.

0-xx Operation and display parameters for basic adjustable frequency drive settings

1-xx Load and motor parameters, includes all load and motor-related parameters

2-xx Brake parameters

3-xx References and ramping parameters, includes DigiPot function

4-xx Limits warnings, setting of limits and warning parameters

5-xx Digital inputs and outputs, includes relay controls

6-xx Analog inputs and outputs

7-xx Controls, setting parameters for speed and process controls

8-xx Communication and option parameters, setting of FC RS485 and FC USB port parameters.

9-xx Profibus parameters

10-xx DeviceNet and CAN Serial Communication parameters

## 4 How to Program

13-xx Smart Logic Control parameters

14-xx Special function parameters

15-xx Drive information parameters

16-xx Readout parameters

17-xx Encoder option parameters

# 4

32-xx MCO 305 Basic parameters

33-xx MCO 305 Advanced parameters

34-xx MCO Data Readout parameters

**4.4.1 0- \*\* Operation/Display**

Par. No. #	Parameter description	Default value	4-set-up	FC 302 only	Change during operation	Conversion index	Type
<b>0-0* Basic Settings</b>							
0-01	Language	[0] English	1 set-up		TRUE	-	Ujnt8
0-02	Motor Speed Unit	[0] RPM	2 set-ups		FALSE	-	Ujnt8
0-03	Regional Settings	[0] International	2 set-ups		FALSE	-	Ujnt8
0-04	Operating State at Power-up (Hand)	[1] Forced stop, ref=old	All set-ups		TRUE	-	Ujnt8
<b>0-1* Set-up Operations</b>							
0-10	Active Set-up	[1] Set-up 1	1 set-up		TRUE	-	Ujnt8
0-11	Edit Set-up	[1] Set-up 1	All set-ups		TRUE	-	Ujnt8
0-12	This Set-up Linked to	[0] Not linked	All set-ups		FALSE	-	Ujnt8
0-13	Readout: Linked Set-ups	0 N/A	All set-ups		FALSE	0	Ujnt16
0-14	Readout: Edit Set-ups / Channel	0 N/A	All set-ups		TRUE	0	Int32
<b>0-2* LCP Display</b>							
0-20	Display Line 1.1 Small	1617	All set-ups		TRUE	-	Ujnt16
0-21	Display Line 1.2 Small	1614	All set-ups		TRUE	-	Ujnt16
0-22	Display Line 1.3 Small	1610	All set-ups		TRUE	-	Ujnt16
0-23	Display Line 2 Large	1613	All set-ups		TRUE	-	Ujnt16
0-24	Display Line 3 Large	1602	All set-ups		TRUE	-	Ujnt16
0-25	My Personal Menu	ExpressionLimit	1 set-up		TRUE	0	Ujnt16
<b>0-3* LCP Cust. Readout</b>							
0-30	Unit for User-defined Readout	[0] None	All set-ups		TRUE	-	Ujnt8
0-31	Min Value of User-defined Readout	0.00 CustomReadoutUnit	All set-ups		TRUE	-2	Int32
0-32	Max Value of User-defined Readout	100.00 CustomReadoutUnit	All set-ups		TRUE	-2	Int32
<b>0-4* LCP Keypad</b>							
0-40	[Hand on] Key on LCP	null	All set-ups		TRUE	-	Ujnt8
0-41	[Off] Key on LCP	null	All set-ups		TRUE	-	Ujnt8
0-42	[Auto on] Key on LCP	null	All set-ups		TRUE	-	Ujnt8
0-43	[Reset] key on LCP	null	All set-ups		TRUE	-	Ujnt8
<b>0-5* Copy/Save</b>							
0-50	LCP Copy	[0] No copy	All set-ups		FALSE	-	Ujnt8
0-51	Set-up Copy	[0] No copy	All set-ups		FALSE	-	Ujnt8
<b>0-6* Password</b>							
0-60	Main Menu Password	100 N/A	1 set-up		TRUE	0	Int16
0-61	Access to Main Menu w/o Password	[0] Full access	1 set-up		TRUE	-	Ujnt8
0-65	Quick Menu Password	200 N/A	1 set-up		TRUE	0	Int16
0-66	Access to Quick Menu w/o Password	[0] Full access	1 set-up		TRUE	-	Ujnt8
0-67	Bus Password Access	0 N/A	All set-ups		TRUE	0	Ujnt16

4.4.2 1- \* Load/Motor

Par. No. #	Parameter description	Default value	4-set-up	FC 302 only	Change during operation	Conversion index	Type
<b>1-0* General Settings</b>							
1-00	Configuration Mode	null	All set-ups		TRUE	-	Uint8
1-01	Motor Control Principle	null	All set-ups		FALSE	-	Uint8
1-02	Flux Motor Feedback Source	[1] 24V encoder	All set-ups	x	FALSE	-	Uint8
1-03	Torque Characteristics	[0] Constant torque	All set-ups		TRUE	-	Uint8
1-04	Overload Mode	[0] High torque	All set-ups		FALSE	-	Uint8
1-05	Local Mode Configuration	[2] As mode par 1-00	All set-ups		TRUE	-	Uint8
<b>1-1* Motor Selection</b>							
1-10	Motor Construction	[0] Asynchronous	All set-ups		FALSE	-	Uint8
<b>1-2* Motor Data</b>							
1-20	Motor Power [kW]	ExpressionLimit	All set-ups		FALSE	1	Uint32
1-21	Motor Power [HP]	ExpressionLimit	All set-ups		FALSE	-2	Uint32
1-22	Motor Voltage	ExpressionLimit	All set-ups		FALSE	0	Uint16
1-23	Motor Frequency	ExpressionLimit	All set-ups		FALSE	0	Uint16
1-24	Motor Current	ExpressionLimit	All set-ups		FALSE	-2	Uint32
1-25	Motor Nominal Speed	ExpressionLimit	All set-ups		FALSE	67	Uint16
1-26	Motor Cont. Rated Torque	ExpressionLimit	All set-ups		FALSE	-1	Uint32
1-29	Automatic Motor Adaptation (AMA)	[0] Off	All set-ups		FALSE	-	Uint8
<b>1-3* Addl. Motor Data</b>							
1-30	Stator Resistance (Rs)	ExpressionLimit	All set-ups		FALSE	-4	Uint32
1-31	Rotor Resistance (Rr)	ExpressionLimit	All set-ups		FALSE	-4	Uint32
1-33	Stator Leakage Reactance (X1)	ExpressionLimit	All set-ups		FALSE	-4	Uint32
1-34	Rotor Leakage Reactance (X2)	ExpressionLimit	All set-ups		FALSE	-4	Uint32
1-35	Main Reactance (Xh)	ExpressionLimit	All set-ups		FALSE	-4	Uint32
1-36	Iron Loss Resistance (Rfe)	ExpressionLimit	All set-ups		FALSE	-3	Uint32
1-37	d-axis Inductance (Ld)	ExpressionLimit	All set-ups	x	FALSE	-4	Int32
1-39	Motor Poles	ExpressionLimit	All set-ups		FALSE	0	Uint8
1-40	Back EMF at 1000 RPM	ExpressionLimit	All set-ups	x	FALSE	0	Uint16
1-41	Motor Angle Offset	0 N/A	All set-ups		FALSE	0	Int16
<b>1-5* Load-Indep. Setting</b>							
1-50	Motor Magnetization at Zero Speed	100 %	All set-ups		TRUE	0	Uint16
1-51	Min Speed Normal Magnetizing [RPM]	ExpressionLimit	All set-ups		TRUE	67	Uint16
1-52	Min Speed Normal Magnetizing [Hz]	ExpressionLimit	All set-ups		TRUE	-1	Uint16
1-53	Model Shift Frequency	ExpressionLimit	All set-ups	x	FALSE	-1	Uint16
1-55	U/f Characteristic - U	ExpressionLimit	All set-ups		TRUE	-1	Uint16
1-56	U/f Characteristic - F	ExpressionLimit	All set-ups		TRUE	-1	Uint16

Par. No. #	Parameter description	Default value	4-set-up	FC 302 only	Change during operation	Conversion index	Type
<b>1-6* Load-Depend. Settg.</b>							
1-60	Low Speed Load Compensation	100 %	All set-ups		TRUE	0	Int16
1-61	High Speed Load Compensation	100 %	All set-ups		TRUE	0	Int16
1-62	Slip Compensation	ExpressionLimit	All set-ups		TRUE	0	Int16
1-63	Slip Compensation Time Constant	ExpressionLimit	All set-ups		TRUE	-2	UInt16
1-64	Resonance Dampening	100 %	All set-ups		TRUE	0	UInt16
1-65	Resonance Dampening Time Constant	5 ms	All set-ups		TRUE	-3	UInt8
1-66	Min. Current at Low Speed	100 %	All set-ups	x	TRUE	0	UInt8
1-67	Load Type	[0] Passive load	All set-ups	x	TRUE	-	UInt8
1-68	Minimum Inertia	ExpressionLimit	All set-ups	x	FALSE	-4	UInt32
1-69	Maximum Inertia	ExpressionLimit	All set-ups	x	FALSE	-4	UInt32
<b>1-7* Start Adjustments</b>							
1-71	Start Delay	0.0 s	All set-ups		TRUE	-1	UInt8
1-72	Start Function	[2] Coast/delay time	All set-ups		TRUE	-	UInt8
1-73	Flying Start	[0] Disabled	All set-ups		FALSE	-	UInt8
1-74	Start Speed [RPM]	ExpressionLimit	All set-ups		TRUE	67	UInt16
1-75	Start Speed [Hz]	ExpressionLimit	All set-ups		TRUE	-1	UInt16
1-76	Start Current	0.00 A	All set-ups		TRUE	-2	UInt32
<b>1-8* Stop Adjustments</b>							
1-80	Function at Stop	[0] Coast	All set-ups		TRUE	-	UInt8
1-81	Min Speed for Function at Stop [RPM]	ExpressionLimit	All set-ups		TRUE	67	UInt16
1-82	Min Speed for Function at Stop [Hz]	ExpressionLimit	All set-ups		TRUE	-1	UInt16
1-83	Precise Stop Function	[0] Precise ramp stop	All set-ups		FALSE	-	UInt8
1-84	Precise Stop Counter Value	100000 N/A	All set-ups		TRUE	0	UInt32
1-85	Precise Stop Speed Compensation Delay	10 ms	All set-ups		TRUE	-3	UInt8
<b>1-9* Motor Temperature</b>							
1-90	Motor Thermal Protection	[0] No protection	All set-ups		TRUE	-	UInt8
1-91	Motor External Fan	[0] No	All set-ups		TRUE	-	UInt16
1-93	Thermistor Resource	[0] None	All set-ups		TRUE	-	UInt8
1-95	KTY Sensor Type	[0] KTY Sensor 1	All set-ups	x	TRUE	-	UInt8
1-96	KTY Thermistor Resource	[0] None	All set-ups	x	TRUE	-	UInt8
1-97	KTY Threshold level	80 °C	1 set-up	x	TRUE	100	Int16

**4.4.3 2- \* Brakes**

Par. No. #	Parameter description	Default value	4-set-up	FC 302 only	Change during operation	Conversion index	Type
<b>2-0* DC Brake</b>							
2-00	DC Hold Current	50 %	All set-ups		TRUE	0	Uint8
2-01	DC Brake Current	50 %	All set-ups		TRUE	0	Uint16
2-02	DC Braking Time	10.0 s	All set-ups		TRUE	-1	Uint16
2-03	DC Brake Cut-in Speed [RPM]	ExpressionLimit	All set-ups		TRUE	67	Uint16
2-04	DC Brake Cut-in Speed [Hz]	ExpressionLimit	All set-ups		TRUE	-1	Uint16
<b>2-1* Brake Energy Funct.</b>							
2-10	Brake Function	null	All set-ups		TRUE	-	Uint8
2-11	Brake Resistor (ohm)	ExpressionLimit	All set-ups		TRUE	0	Uint16
2-12	Brake Power Limit (kW)	ExpressionLimit	All set-ups		TRUE	0	Uint32
2-13	Brake Power Monitoring	[0] Off	All set-ups		TRUE	-	Uint8
2-15	Brake Check	[0] Off	All set-ups		TRUE	-	Uint8
2-16	AC Brake Max. Current	100.0 %	All set-ups		TRUE	-1	Uint32
2-17	Over-voltage Control	[0] Disabled	All set-ups		TRUE	-	Uint8
<b>2-2* Mechanical Brake</b>							
2-20	Release Brake Current	ImaxVLT (P1637)	All set-ups		TRUE	-2	Uint32
2-21	Activate Brake Speed [RPM]	ExpressionLimit	All set-ups		TRUE	67	Uint16
2-22	Activate Brake Speed [Hz]	ExpressionLimit	All set-ups		TRUE	-1	Uint16
2-23	Activate Brake Delay	0.0 s	All set-ups		TRUE	-1	Uint8
2-24	Stop Delay	0.0 s	All set-ups		TRUE	-1	Uint8
2-25	Brake Release Time	0.20 s	All set-ups		TRUE	-2	Uint16
2-26	Torque Ref	0.00 %	All set-ups		TRUE	-2	Int16
2-27	Torque Ramp Time	0.2 s	All set-ups		TRUE	-1	Uint8
2-28	Gain Boost Factor	1.00 N/A	All set-ups		TRUE	-2	Uint16



### 4.4.4 3- \*\* Reference / Ramps

Par. No. #	Parameter description	Default value	4-set-up	FC 302 only	Change during operation	Conversion index	Type
<b>3-0* Reference Limits</b>							
3-00	Reference Range	null	All set-ups		TRUE	-	Ujnt8
3-01	Reference/Feedback Unit	null	All set-ups		TRUE	-	Ujnt8
3-02	Minimum Reference	ExpressionLimit	All set-ups		TRUE	-3	Int32
3-03	Maximum Reference	ExpressionLimit	All set-ups		TRUE	-3	Int32
3-04	Reference Function	[0] Sum	All set-ups		TRUE	-	Ujnt8
<b>3-1* References</b>							
3-10	Preset Reference	0.00 %	All set-ups		TRUE	-2	Int16
3-11	Jog Speed [Hz]	ExpressionLimit	All set-ups		TRUE	-1	Ujnt16
3-12	Catch up/slow-down Value	0.00 %	All set-ups		TRUE	-2	Int16
3-13	Reference Site	[0] Linked to Hand / Auto	All set-ups		TRUE	-	Ujnt8
3-14	Preset Relative Reference	0.00 %	All set-ups		TRUE	-2	Int32
3-15	Reference Resource 1	null	All set-ups		TRUE	-	Ujnt8
3-16	Reference Resource 2	null	All set-ups		TRUE	-	Ujnt8
3-17	Reference Resource 3	null	All set-ups		TRUE	-	Ujnt8
3-18	Relative Scaling Reference Resource	[0] No function	All set-ups		TRUE	-	Ujnt8
3-19	Jog Speed [RPM]	ExpressionLimit	All set-ups		TRUE	67	Ujnt16
<b>3-4* Ramp 1</b>							
3-40	Ramp 1 Type	[0] Linear	All set-ups		TRUE	-	Ujnt8
3-41	Ramp 1 Ramp-up Time	ExpressionLimit	All set-ups		TRUE	-2	Ujnt32
3-42	Ramp 1 Ramp-down Time	ExpressionLimit	All set-ups		TRUE	-2	Ujnt32
3-45	Ramp 1 S-ramp Ratio at Accel. Start	50 %	All set-ups		TRUE	0	Ujnt8
3-46	Ramp 1 S-ramp Ratio at Accel. End	50 %	All set-ups		TRUE	0	Ujnt8
3-47	Ramp 1 S-ramp Ratio at Decel. Start	50 %	All set-ups		TRUE	0	Ujnt8
3-48	Ramp 1 S-ramp Ratio at Decel. End	50 %	All set-ups		TRUE	0	Ujnt8
<b>3-5* Ramp 2</b>							
3-50	Ramp 2 Type	[0] Linear	All set-ups		TRUE	-	Ujnt8
3-51	Ramp 2 Ramp-up Time	ExpressionLimit	All set-ups		TRUE	-2	Ujnt32
3-52	Ramp 2 Ramp-down Time	ExpressionLimit	All set-ups		TRUE	-2	Ujnt32
3-55	Ramp 2 S-ramp Ratio at Accel. Start	50 %	All set-ups		TRUE	0	Ujnt8
3-56	Ramp 2 S-ramp Ratio at Accel. End	50 %	All set-ups		TRUE	0	Ujnt8
3-57	Ramp 2 S-ramp Ratio at Decel. Start	50 %	All set-ups		TRUE	0	Ujnt8
3-58	Ramp 2 S-ramp Ratio at Decel. End	50 %	All set-ups		TRUE	0	Ujnt8

Par. No. #	Parameter description	Default value	4-set-up	FC 302 only	Change during operation	Conversion index	Type
<b>3-6* Ramp 3</b>							
3-60	Ramp 3 Type	[0] Linear	All set-ups		TRUE	-	Uint8
3-61	Ramp 3 Ramp-up Time	ExpressionLimit	All set-ups		TRUE	-2	Uint32
3-62	Ramp 3 Ramp-down Time	ExpressionLimit	All set-ups		TRUE	-2	Uint32
3-65	Ramp 3 S-ramp Ratio at Accel. Start	50 %	All set-ups		TRUE	0	Uint8
3-66	Ramp 3 S-ramp Ratio at Accel. End	50 %	All set-ups		TRUE	0	Uint8
3-67	Ramp 3 S-ramp Ratio at Decel. Start	50 %	All set-ups		TRUE	0	Uint8
3-68	Ramp 3 S-ramp Ratio at Decel. End	50 %	All set-ups		TRUE	0	Uint8
<b>3-7* Ramp 4</b>							
3-70	Ramp 4 Type	[0] Linear	All set-ups		TRUE	-	Uint8
3-71	Ramp 4 Ramp-up Time	ExpressionLimit	All set-ups		TRUE	-2	Uint32
3-72	Ramp 4 Ramp-down Time	ExpressionLimit	All set-ups		TRUE	-2	Uint32
3-75	Ramp 4 S-ramp Ratio at Accel. Start	50 %	All set-ups		TRUE	0	Uint8
3-76	Ramp 4 S-ramp Ratio at Accel. End	50 %	All set-ups		TRUE	0	Uint8
3-77	Ramp 4 S-ramp Ratio at Decel. Start	50 %	All set-ups		TRUE	0	Uint8
3-78	Ramp 4 S-ramp Ratio at Decel. End	50 %	All set-ups		TRUE	0	Uint8
<b>3-8* Other Ramps</b>							
3-80	Jog Ramp Time	ExpressionLimit	All set-ups		TRUE	-2	Uint32
3-81	Quick Stop Ramp Time	ExpressionLimit	2 set-ups		TRUE	-2	Uint32
3-82	Quick Stop Ramp Type	[0] Linear	All set-ups		TRUE	-	Uint8
3-83	Quick Stop S-ramp Ratio at Decel. Start	50 %	All set-ups		TRUE	0	Uint8
3-84	Quick Stop S-ramp Ratio at Decel. End	50 %	All set-ups		TRUE	0	Uint8
<b>3-9* Digital Pot. meter</b>							
3-90	Step Size	0.10 %	All set-ups		TRUE	-2	Uint16
3-91	Ramp Time	1.00 s	All set-ups		TRUE	-2	Uint32
3-92	Power Restore	[0] Off	All set-ups		TRUE	-	Uint8
3-93	Maximum Limit	100 %	All set-ups		TRUE	0	Int16
3-94	Minimum Limit	-100 %	All set-ups		TRUE	0	Int16
3-95	Ramp Delay	ExpressionLimit	All set-ups		TRUE	-3	TimD

**4.4.5 4- \*\* Limits / Warnings**

Par. No. #	Parameter description	Default value	4-set-up	FC 302 only	Change during operation	Conversion index	Type
<b>4-1* Motor Limits</b>							
4-10	Motor Speed Direction	null	All set-ups		FALSE	-	Uint8
4-11	Motor Speed Low Limit [RPM]	ExpressionLimit	All set-ups		TRUE	67	Uint16
4-12	Motor Speed Low Limit [Hz]	ExpressionLimit	All set-ups		TRUE	-1	Uint16
4-13	Motor Speed High Limit [RPM]	ExpressionLimit	All set-ups		TRUE	67	Uint16
4-14	Motor Speed High Limit [Hz]	ExpressionLimit	All set-ups		TRUE	-1	Uint16
4-16	Torque Limit Motor Mode	ExpressionLimit	All set-ups		TRUE	-1	Uint16
4-17	Torque Limit Generator Mode	100.0 %	All set-ups		TRUE	-1	Uint16
4-18	Current Limit	ExpressionLimit	All set-ups		TRUE	-1	Uint32
4-19	Max Output Frequency	132.0 Hz	All set-ups		FALSE	-1	Uint16
<b>4-2* Limit Factors</b>							
4-20	Torque Limit Factor Source	[0] No function	All set-ups		TRUE	-	Uint8
4-21	Speed Limit Factor Source	[0] No function	All set-ups		TRUE	-	Uint8
<b>4-3* Motor Fb Monitor</b>							
4-30	Motor Feedback Loss Function	[2] Trip	All set-ups		TRUE	-	Uint8
4-31	Motor Feedback Speed Error	300 RPM	All set-ups		TRUE	67	Uint16
4-32	Motor Feedback Loss Timeout	0.05 s	All set-ups		TRUE	-2	Uint16
4-34	Tracking Error Function	[0] Disable	All set-ups		TRUE	-	Uint8
4-35	Tracking Error	10 RPM	All set-ups		TRUE	67	Uint16
4-36	Tracking Error Timeout	1.00 s	All set-ups		TRUE	-2	Uint16
4-37	Tracking Error Ramping	100 RPM	All set-ups		TRUE	67	Uint16
4-38	Tracking Error Ramping Timeout	1.00 s	All set-ups		TRUE	-2	Uint16
4-39	Tracking Error After Ramping Timeout	5.00 s	All set-ups		TRUE	-2	Uint16
<b>4-5* Adj. Warnings</b>							
4-50	Warning Current Low	0.00 A	All set-ups		TRUE	-2	Uint32
4-51	Warning Current High	ImaxVLT (P1637)	All set-ups		TRUE	-2	Uint32
4-52	Warning Speed Low	0 RPM	All set-ups		TRUE	67	Uint16
4-53	Warning Speed High	outputSpeedHighLimit (P413)	All set-ups		TRUE	67	Uint16
4-54	Warning Reference Low	-999999,999 N/A	All set-ups		TRUE	-3	Int32
4-55	Warning Reference High	999999,999 N/A	All set-ups		TRUE	-3	Int32
4-56	Warning Feedback Low	-999999,999 ReferenceFeedbackUnit	All set-ups		TRUE	-3	Int32
4-57	Warning Feedback High	999999,999 ReferenceFeedbackUnit	All set-ups		TRUE	-3	Int32
4-58	Missing Motor Phase Function	null	All set-ups		TRUE	-	Uint8
<b>4-6* Speed Bypass</b>							
4-60	Bypass Speed From [RPM]	ExpressionLimit	All set-ups		TRUE	67	Uint16
4-61	Bypass Speed From [Hz]	ExpressionLimit	All set-ups		TRUE	-1	Uint16
4-62	Bypass Speed to [RPM]	ExpressionLimit	All set-ups		TRUE	67	Uint16
4-63	Bypass Speed To [Hz]	ExpressionLimit	All set-ups		TRUE	-1	Uint16

4.4.6 5- \* Digital In/Out

Par. No. #	Parameter description	Default value	4-set-up	FC 302 only	Change during operation	Conversion index	Type
<b>5-0* Digital I/O mode</b>							
5-00	Digital I/O Mode	[0] PNP	All set-ups		FALSE	-	Ujnt8
5-01	Terminal 27 Mode	[0] Input	All set-ups		TRUE	-	Ujnt8
5-02	Terminal 29 Mode	[0] Input	All set-ups	x	TRUE	-	Ujnt8
<b>5-1* Digital Inputs</b>							
5-10	Terminal 18 Digital Input	null	All set-ups		TRUE	-	Ujnt8
5-11	Terminal 19 Digital Input	null	All set-ups		TRUE	-	Ujnt8
5-12	Terminal 27 Digital Input	null	All set-ups		TRUE	-	Ujnt8
5-13	Terminal 29 Digital Input	null	All set-ups	x	TRUE	-	Ujnt8
5-14	Terminal 32 Digital Input	null	All set-ups		TRUE	-	Ujnt8
5-15	Terminal 33 Digital Input	null	All set-ups		TRUE	-	Ujnt8
5-16	Terminal X30/2 Digital Input	null	All set-ups		TRUE	-	Ujnt8
5-17	Terminal X30/3 Digital Input	null	All set-ups		TRUE	-	Ujnt8
5-18	Terminal X30/4 Digital Input	null	All set-ups		TRUE	-	Ujnt8
5-19	Terminal 37 Safe Stop	[1] Safe Stop Alarm	1 set-up		TRUE	-	Ujnt8
5-20	Terminal X46/1 Digital Input	[0] No operation	All set-ups		TRUE	-	Ujnt8
5-21	Terminal X46/3 Digital Input	[0] No operation	All set-ups		TRUE	-	Ujnt8
5-22	Terminal X46/5 Digital Input	[0] No operation	All set-ups		TRUE	-	Ujnt8
5-23	Terminal X46/7 Digital Input	[0] No operation	All set-ups		TRUE	-	Ujnt8
5-24	Terminal X46/9 Digital Input	[0] No operation	All set-ups		TRUE	-	Ujnt8
5-25	Terminal X46/11 Digital Input	[0] No operation	All set-ups		TRUE	-	Ujnt8
5-26	Terminal X46/13 Digital Input	[0] No operation	All set-ups		TRUE	-	Ujnt8
<b>5-3* Digital Outputs</b>							
5-30	Terminal 27 Digital Output	null	All set-ups		TRUE	-	Ujnt8
5-31	Terminal 29 digital Output	null	All set-ups	x	TRUE	-	Ujnt8
5-32	Term X30/6 Digi Out (MCB 101)	null	All set-ups		TRUE	-	Ujnt8
5-33	Term X30/7 Digi Out (MCB 101)	null	All set-ups		TRUE	-	Ujnt8
<b>5-4* Relays</b>							
5-40	Function Relay	null	All set-ups		TRUE	-	Ujnt8
5-41	On Delay, Relay	0.01 s	All set-ups		TRUE	-2	Ujnt16
5-42	Off Delay, Relay	0.01 s	All set-ups		TRUE	-2	Ujnt16

Par. No. #	Parameter description	Default value	4-set-up	FC 302 only	Change during operation	Conversion index	Type
<b>5-5* Pulse Input</b>							
5-50	Term. 29 Low Frequency	100 Hz	All set-ups	x	TRUE	0	Uint32
5-51	Term. 29 High Frequency	100 Hz	All set-ups	x	TRUE	0	Uint32
5-52	Term. 29 Low Ref./Feedb. Value	0.000 ReferenceFeedbackUnit	All set-ups	x	TRUE	-3	Int32
5-53	Term. 29 High Ref./Feedb. Value	ExpressionLimit	All set-ups	x	TRUE	-3	Int32
5-54	Pulse Filter Time Constant #29	100 ms	All set-ups	x	FALSE	-3	Uint16
5-55	Term. 33 Low Frequency	100 Hz	All set-ups		TRUE	0	Uint32
5-56	Term. 33 High Frequency	100 Hz	All set-ups		TRUE	0	Uint32
5-57	Term. 33 Low Ref./Feedb. Value	0.000 ReferenceFeedbackUnit	All set-ups		TRUE	-3	Int32
5-58	Term. 33 High Ref./Feedb. Value	ExpressionLimit	All set-ups		TRUE	-3	Int32
5-59	Pulse Filter Time Constant #33	100 ms	All set-ups		FALSE	-3	Uint16
<b>5-6* Pulse Output</b>							
5-60	Terminal 27 Pulse Output Variable	null	All set-ups		TRUE	-	Uint8
5-62	Pulse Output Max Freq #27	ExpressionLimit	All set-ups		TRUE	0	Uint32
5-63	Terminal 29 Pulse Output Variable	null	All set-ups	x	TRUE	-	Uint8
5-65	Pulse Output Max Freq #29	ExpressionLimit	All set-ups	x	TRUE	0	Uint32
5-66	Terminal X30/6 Pulse Output Variable	null	All set-ups		TRUE	-	Uint8
5-68	Pulse Output Max Freq #X30/6	ExpressionLimit	All set-ups		TRUE	0	Uint32
<b>5-7* 24V Encoder Input</b>							
5-70	Term 32/33 Pulses per Revolution	1024 N/A	All set-ups		FALSE	0	Uint16
5-71	Term 32/33 Encoder Direction	[0] Clockwise	All set-ups		FALSE	-	Uint8
<b>5-9* Bus Controlled</b>							
5-90	Digital & Relay Bus Control	0 N/A	All set-ups		TRUE	0	Uint32
5-93	Pulse Out #27 Bus Control	0.00 %	All set-ups		TRUE	-2	N2
5-94	Pulse Out #27 Timeout Preset	0.00 %	1 set-up		TRUE	-2	Uint16
5-95	Pulse Out #29 Bus Control	0.00 %	All set-ups	x	TRUE	-2	N2
5-96	Pulse Out #29 Timeout Preset	0.00 %	1 set-up	x	TRUE	-2	Uint16

4.4.7 6- \* Analog In/Out

Par. No. #	Parameter description	Default value	4-set-up	FC 302 only	Change during operation	Conversion index	Type
<b>6-0* Analog I/O Mode</b>							
6-00	Live Zero Timeout Time	10 s	All set-ups		TRUE	0	Uint8
6-01	Live Zero Timeout Function	[0] Off	All set-ups		TRUE	-	Uint8
<b>6-1* Analog Input 1</b>							
6-10	Terminal 53 Low Voltage	0.07 V	All set-ups		TRUE	-2	Int16
6-11	Terminal 53 High Voltage	10.00 V	All set-ups		TRUE	-2	Int16
6-12	Terminal 53 Low Current	0.14 mA	All set-ups		TRUE	-5	Int16
6-13	Terminal 53 High Current	20.00 mA	All set-ups		TRUE	-5	Int16
6-14	Terminal 53 Low Ref./Feedb. Value	0 ReferenceFeedBackUnit	All set-ups		TRUE	-3	Int32
6-15	Terminal 53 High Ref./Feedb. Value	ExpressionLimit	All set-ups		TRUE	-3	Int32
6-16	Terminal 53 Filter Time Constant	0.001 s	All set-ups		TRUE	-3	Uint16
<b>6-2* Analog Input 2</b>							
6-20	Terminal 54 Low Voltage	0.07 V	All set-ups		TRUE	-2	Int16
6-21	Terminal 54 High Voltage	10.00 V	All set-ups		TRUE	-2	Int16
6-22	Terminal 54 Low Current	0.14 mA	All set-ups		TRUE	-5	Int16
6-23	Terminal 54 High Current	20.00 mA	All set-ups		TRUE	-5	Int16
6-24	Terminal 54 Low Ref./Feedb. Value	0 ReferenceFeedBackUnit	All set-ups		TRUE	-3	Int32
6-25	Terminal 54 High Ref./Feedb. Value	ExpressionLimit	All set-ups		TRUE	-3	Int32
6-26	Terminal 54 Filter Time Constant	0.001 s	All set-ups		TRUE	-3	Uint16
<b>6-3* Analog Input 53</b>							
6-30	Terminal X30/11 Low Voltage	0.07 V	All set-ups		TRUE	-2	Int16
6-31	Terminal X30/11 High Voltage	10.00 V	All set-ups		TRUE	-2	Int16
6-34	Term. X30/11 Low Ref./Feedb. Value	0 ReferenceFeedBackUnit	All set-ups		TRUE	-3	Int32
6-35	Term. X30/11 High Ref./Feedb. Value	ExpressionLimit	All set-ups		TRUE	-3	Int32
6-36	Term. X30/11 Filter Time Constant	0.001 s	All set-ups		TRUE	-3	Uint16
<b>6-4* Analog Input 4</b>							
6-40	Terminal X30/12 Low Voltage	0.07 V	All set-ups		TRUE	-2	Int16
6-41	Terminal X30/12 High Voltage	10.00 V	All set-ups		TRUE	-2	Int16
6-44	Term. X30/12 Low Ref./Feedb. Value	0 ReferenceFeedBackUnit	All set-ups		TRUE	-3	Int32
6-45	Term. X30/12 High Ref./Feedb. Value	ExpressionLimit	All set-ups		TRUE	-3	Int32
6-46	Term. X30/12 Filter Time Constant	0.001 s	All set-ups		TRUE	-3	Uint16
<b>6-5* Analog Output 1</b>							
6-50	Terminal 42 Output	null	All set-ups		TRUE	-	Uint8
6-51	Terminal 42 Output Min Scale	0.00 %	All set-ups		TRUE	-2	Int16
6-52	Terminal 42 Output Max Scale	100.00 %	All set-ups		TRUE	-2	Int16
6-53	Terminal 42 Output Bus Control	0.00 %	All set-ups		TRUE	-2	N2
6-54	Terminal 42 Output Timeout Preset	0.00 %	1 set-up		TRUE	-2	Uint16
<b>6-6* Analog Output 2</b>							
6-60	Terminal X30/8 Output	null	All set-ups		TRUE	-	Uint8
6-61	Terminal X30/8 Min. Scale	0.00 %	All set-ups		TRUE	-2	Int16
6-62	Terminal X30/8 Max. Scale	100.00 %	All set-ups		TRUE	-2	Int16
<b>6-7* Analog Output 3</b>							
6-70	Terminal X45/1 Output	null	All set-ups		TRUE	-	Uint8
6-71	Terminal X45/1 Min. Scale	0.00 %	All set-ups		TRUE	-2	Int16
6-72	Terminal X45/1 Max. Scale	100.00 %	All set-ups		TRUE	-2	Int16
6-73	Terminal X45/1 Bus Control	0.00 %	All set-ups		TRUE	-2	N2
6-74	Terminal X45/1 Output Timeout Preset	0.00 %	1 set-up		TRUE	-2	Uint16
<b>6-8* Analog Output 4</b>							
6-80	Terminal X45/3 Output	null	All set-ups		TRUE	-	Uint8
6-81	Terminal X45/3 Min. Scale	0.00 %	All set-ups		TRUE	-2	Int16
6-82	Terminal X45/3 Max. Scale	100.00 %	All set-ups		TRUE	-2	Int16
6-83	Terminal X45/3 Bus Control	0.00 %	All set-ups		TRUE	-2	N2
6-84	Terminal X45/3 Output Timeout Preset	0.00 %	1 set-up		TRUE	-2	Uint16

**4.4.8 7- \*\* Controllers**

Par. No. #	Parameter description	Default value	4-set-up	FC 302 only	Change during operation	Conversion index	Type
<b>7-0* Speed PID Ctrl.</b>							
7-00	Speed PID Feedback Source	null	All set-ups		FALSE	-	Uint8
7-02	Speed PID Proportional Gain	ExpressionLimit	All set-ups		TRUE	-3	Uint16
7-03	Speed PID Integral Time	ExpressionLimit	All set-ups		TRUE	-4	Uint32
7-04	Speed PID Differentiation Time	ExpressionLimit	All set-ups		TRUE	-4	Uint16
7-05	Speed PID Diff. Gain Limit	5.0 N/A	All set-ups		TRUE	-1	Uint16
7-06	Speed PID Lowpass Filter Time	10.0 ms	All set-ups		TRUE	-4	Uint16
7-07	Speed PID Feedback Gear Ratio	1.0000 N/A	All set-ups		FALSE	-4	Uint32
7-08	Speed PID Feed Forward Factor	0 %	All set-ups		FALSE	0	Uint16
<b>7-1* Torque PI Ctrl.</b>							
7-12	Torque PI Proportional Gain	100 %	All set-ups		TRUE	0	Uint16
7-13	Torque PI Integration Time	0.020 s	All set-ups		TRUE	-3	Uint16
<b>7-2* Process Ctrl. Feedb</b>							
7-20	Process CL Feedback 1 Resource	[0] No function	All set-ups		TRUE	-	Uint8
7-22	Process CL Feedback 2 Resource	[0] No function	All set-ups		TRUE	-	Uint8
<b>7-3* Process PID Ctrl.</b>							
7-30	Process PID Normal/Inverse Control	[0] Normal	All set-ups		TRUE	-	Uint8
7-31	Process PID Anti Windup	[1] On	All set-ups		TRUE	-	Uint8
7-32	Process PID Controller Start Value	0 RPM	All set-ups		TRUE	67	Uint16
7-33	Process PID Proportional Gain	0.01 N/A	All set-ups		TRUE	-2	Uint16
7-34	Process PID Integral Time	10000.00 s	All set-ups		TRUE	-2	Uint32
7-35	Process PID Differentiation Time	0.00 s	All set-ups		TRUE	-2	Uint16
7-36	Process PID Differentiation Gain Limit	5.0 N/A	All set-ups		TRUE	-1	Uint16
7-38	Process PID Feed Forward Factor	0 %	All set-ups		TRUE	0	Uint16
7-39	On Reference Bandwidth	5 %	All set-ups		TRUE	0	Uint8
<b>7-4* Advanced Process PID Ctrl.</b>							
7-40	Process PID I-part Reset	[0] No	All set-ups		TRUE	-	Uint8
7-41	Process PID Output Neg. Clamp	-100 %	All set-ups		TRUE	0	Int16
7-42	Process PID Output Pos. Clamp	100 %	All set-ups		TRUE	0	Int16
7-43	Process PID Gain Scale at Min. Ref.	100 %	All set-ups		TRUE	0	Int16
7-44	Process PID Gain Scale at Max. Ref.	100 %	All set-ups		TRUE	0	Int16
7-45	Process PID Feed Fwd Resource	[0] No function	All set-ups		TRUE	-	Uint8
7-46	Process PID Feed Fwd Normal/ Inv. Ctrl.	[0] Normal	All set-ups		TRUE	-	Uint8
7-49	Process PID Output Normal/ Inv. Ctrl.	[0] Normal	All set-ups		TRUE	-	Uint8
<b>7-5* Position PID Ctrl.</b>							
7-50	Process PID Extended PID	[1] Enabled	All set-ups		TRUE	-	Uint8
7-51	Process PID Feed Fwd Gain	1.00 N/A	All set-ups		TRUE	-2	Uint16
7-52	Process PID Feed Fwd Ramp up	0.01 s	All set-ups		TRUE	-2	Uint32
7-53	Process PID Feed Fwd Ramp down	0.01 s	All set-ups		TRUE	-2	Uint32
7-56	Process PID Ref. Filter Time	0.001 s	All set-ups		TRUE	-3	Uint16
7-57	Process PID Fb. Filter Time	0.001 s	All set-ups		TRUE	-3	Uint16

4.4.9 8- \* \* Comm. and Options

Par. No. #	Parameter description	Default value	4-set-up	FC 302 only	Change during operation	Conversion index	Type
<b>8-0* General Settings</b>							
8-01	Control Site	[0] Digital and ctrl. word	All set-ups		TRUE	-	Ujnt8
8-02	Control Word Source	null	All set-ups		TRUE	-	Ujnt8
8-03	Control Word Timeout Time	1.0 s	1 set-up		TRUE	-1	Ujnt32
8-04	Control Word Timeout Function	null	1 set-up		TRUE	-	Ujnt8
8-05	End-of-Timeout Function	[1] Resume set-up	1 set-up		TRUE	-	Ujnt8
8-06	Reset Control Word Timeout	[0] Do not reset	All set-ups		TRUE	-	Ujnt8
8-07	Diagnosis Trigger	[0] Disable	2 set-ups		TRUE	-	Ujnt8
<b>8-1* Ctrl. Word Settings</b>							
8-10	Control Word Profile	[0] FC profile	All set-ups		TRUE	-	Ujnt8
8-13	Configurable Status Word STW	null	All set-ups		TRUE	-	Ujnt8
8-14	Configurable Control Word CTW	[1] Profile default	All set-ups		TRUE	-	Ujnt8
<b>8-3* FC Port Settings</b>							
8-30	Protocol	[0] FC	1 set-up		TRUE	-	Ujnt8
8-31	Address	1 N/A	1 set-up		TRUE	0	Ujnt8
8-32	FC Port Baud Rate	null	1 set-up		TRUE	-	Ujnt8
8-33	Parity / Stop Bits	[0] Even Parity, 1 Stop Bit	1 set-up		TRUE	-	Ujnt8
8-35	Minimum Response Delay	10 ms	All set-ups		TRUE	-3	Ujnt16
8-36	Max Response Delay	ExpressionLimit	1 set-up		TRUE	-3	Ujnt16
8-37	Max Inter-Char Delay	ExpressionLimit	1 set-up		TRUE	-5	Ujnt16
<b>8-4* FC MC protocol set</b>							
8-40	Telegram selection	[1] Standard telegram 1	2 set-ups		TRUE	-	Ujnt8
<b>8-5* Digital/Bus</b>							
8-50	Coasting Select	[3] Logic OR	All set-ups		TRUE	-	Ujnt8
8-51	Quick Stop Select	[3] Logic OR	All set-ups		TRUE	-	Ujnt8
8-52	DC Brake Select	[3] Logic OR	All set-ups		TRUE	-	Ujnt8
8-53	Start Select	[3] Logic OR	All set-ups		TRUE	-	Ujnt8
8-54	Reverse Select	[3] Logic OR	All set-ups		TRUE	-	Ujnt8
8-55	Set-up Select	[3] Logic OR	All set-ups		TRUE	-	Ujnt8
8-56	Preset Reference Select	[3] Logic OR	All set-ups		TRUE	-	Ujnt8
<b>8-8* FC Port Diagnostics</b>							
8-80	Bus Message Count	0 N/A	All set-ups		TRUE	0	Ujnt32
8-81	Bus Error Count	0 N/A	All set-ups		TRUE	0	Ujnt32
8-82	Slave Messages Rcvd	0 N/A	All set-ups		TRUE	0	Ujnt32
8-83	Slave Error Count	0 N/A	All set-ups		TRUE	0	Ujnt32
<b>8-9* Bus Jog</b>							
8-90	Bus Jog 1 Speed	100 RPM	All set-ups		TRUE	67	Ujnt16
8-91	Bus Jog 2 Speed	200 RPM	All set-ups		TRUE	67	Ujnt16



### 4.4.10 9- \*\* Profibus

Par. No. #	Parameter description	Default value	4-set-up	FC 302 only	Change during operation	Conversion index	Type
9-00	Setpoint	0 N/A	All set-ups		TRUE	0	Uint16
9-07	Actual Value	0 N/A	All set-ups		FALSE	0	Uint16
9-15	PCD Write Configuration	ExpressionLimit	2 set-ups		TRUE	-	Uint16
9-16	PCD Read Configuration	ExpressionLimit	2 set-ups		TRUE	-	Uint16
9-18	Node Address	126 N/A	1 set-up		TRUE	0	Uint8
9-22	Telegram Selection	[108] PPO 8	1 set-up		TRUE	-	Uint8
9-23	Parameters for Signals	0	All set-ups		TRUE	-	Uint16
9-27	Parameter Edit	[1] Enabled	2 set-ups		FALSE	-	Uint16
9-28	Process Control	[1] Enable cyclic master	2 set-ups		FALSE	-	Uint16
9-31	Safe Address	0 N/A	1 set-up		TRUE	0	Uint16
9-44	Fault Message Counter	0 N/A	All set-ups		TRUE	0	Uint16
9-45	Fault Code	0 N/A	All set-ups		TRUE	0	Uint16
9-47	Fault Number	0 N/A	All set-ups		TRUE	0	Uint16
9-52	Fault Situation Counter	0 N/A	All set-ups		TRUE	0	Uint16
9-53	Profibus Warning Word	0 N/A	All set-ups		TRUE	0	Uint16
9-63	Actual Baud Rate	0 N/A	All set-ups		TRUE	0	V2
9-64	Device Identification	[255] No baud rate found	All set-ups		TRUE	-	Uint8
9-65	Profile Number	0 N/A	All set-ups		TRUE	0	Uint16
9-67	Control Word 1	0 N/A	All set-ups		TRUE	0	OctStr[2]
9-68	Status Word 1	0 N/A	All set-ups		TRUE	0	V2
9-71	Profibus Save Data Values	[0] Off	All set-ups		TRUE	-	Uint8
9-72	ProfibusDriveReset	[0] No action	1 set-up		FALSE	-	Uint8
9-80	Defined Parameters (1)	0 N/A	All set-ups		FALSE	0	Uint16
9-81	Defined Parameters (2)	0 N/A	All set-ups		FALSE	0	Uint16
9-82	Defined Parameters (3)	0 N/A	All set-ups		FALSE	0	Uint16
9-83	Defined Parameters (4)	0 N/A	All set-ups		FALSE	0	Uint16
9-84	Defined Parameters (5)	0 N/A	All set-ups		FALSE	0	Uint16
9-90	Changed Parameters (1)	0 N/A	All set-ups		FALSE	0	Uint16
9-91	Changed Parameters (2)	0 N/A	All set-ups		FALSE	0	Uint16
9-92	Changed Parameters (3)	0 N/A	All set-ups		FALSE	0	Uint16
9-93	Changed Parameters (4)	0 N/A	All set-ups		FALSE	0	Uint16
9-94	Changed parameters (5)	0 N/A	All set-ups		FALSE	0	Uint16
9-99	Profibus Revision Counter	0 N/A	All set-ups		TRUE	0	Uint16

4.4.11 10- \*\* CAN Ser. Com. Bus

Par. No. #	Parameter description	Default value	4-set-up	FC 302 only	Change during operation	Conversion index	Type
<b>10-0* Common Settings</b>							
10-00	CAN Protocol	null	2 set-ups		FALSE	-	Uint8
10-01	Baud Rate Select	null	2 set-ups		TRUE	-	Uint8
10-02	MAC ID	ExpressionLimit	2 set-ups		TRUE	0	Uint8
10-05	Readout Transmit Error Counter	0 N/A	All set-ups		TRUE	0	Uint8
10-06	Readout Receive Error Counter	0 N/A	All set-ups		TRUE	0	Uint8
10-07	Readout Bus Off Counter	0 N/A	All set-ups		TRUE	0	Uint8
<b>10-1* DeviceNet</b>							
10-10	Process Data Type Selection	null	All set-ups		TRUE	-	Uint8
10-11	Process Data Config Write	ExpressionLimit	All set-ups		TRUE	-	Uint16
10-12	Process Data Config Read	ExpressionLimit	All set-ups		TRUE	-	Uint16
10-13	Warning Parameter	0 N/A	All set-ups		TRUE	0	Uint16
10-14	Net Reference	[0] Off	2 set-ups		TRUE	-	Uint8
10-15	Net Control	[0] Off	2 set-ups		TRUE	-	Uint8
<b>10-2* COS Filters</b>							
10-20	COS Filter 1	0 N/A	All set-ups		FALSE	0	Uint16
10-21	COS Filter 2	0 N/A	All set-ups		FALSE	0	Uint16
10-22	COS Filter 3	0 N/A	All set-ups		FALSE	0	Uint16
10-23	COS Filter 4	0 N/A	All set-ups		FALSE	0	Uint16
<b>10-3* Parameter Access</b>							
10-30	Array Index	0 N/A	2 set-ups		TRUE	0	Uint8
10-31	Store Data Values	[0] Off	All set-ups		TRUE	-	Uint8
10-32	DeviceNet Revision	ExpressionLimit	All set-ups		TRUE	0	Uint16
10-33	Store Always	[0] Off	1 set-up		TRUE	-	Uint8
10-34	DeviceNet Product Code	ExpressionLimit	1 set-up		TRUE	0	Uint16
10-39	DeviceNet F Parameters	0 N/A	All set-ups		TRUE	0	Uint32
<b>10-5* CANopen</b>							
10-50	Process Data Config Write.	ExpressionLimit	2 set-ups		TRUE	-	Uint16
10-51	Process Data Config Read.	ExpressionLimit	2 set-ups		TRUE	-	Uint16

### 4.4.12 13- \*\* Smart Logic

Par. No. #	Parameter description	Default value	4-set-up	FC 302 only	Change during operation	Conversion index	Type
<b>13-0* SLC Settings</b>							
13-00	SL Controller Mode	null	2 set-ups		TRUE	-	Ujnt8
13-01	Start Event	null	2 set-ups		TRUE	-	Ujnt8
13-02	Stop Event	null	2 set-ups		TRUE	-	Ujnt8
13-03	Reset SLC	[0] Do not reset SLC	All set-ups		TRUE	-	Ujnt8
<b>13-1* Comparators</b>							
13-10	Comparator Operand	null	2 set-ups		TRUE	-	Ujnt8
13-11	Comparator Operator	null	2 set-ups		TRUE	-	Ujnt8
13-12	Comparator Value	ExpressionLimit	2 set-ups		TRUE	-3	Int32
<b>13-2* Timers</b>							
13-20	SL Controller Timer	ExpressionLimit	1 set-up		TRUE	-3	TimD
<b>13-4* Logic Rules</b>							
13-40	Logic Rule Boolean 1	null	2 set-ups		TRUE	-	Ujnt8
13-41	Logic Rule Operator 1	null	2 set-ups		TRUE	-	Ujnt8
13-42	Logic Rule Boolean 2	null	2 set-ups		TRUE	-	Ujnt8
13-43	Logic Rule Operator 2	null	2 set-ups		TRUE	-	Ujnt8
13-44	Logic Rule Boolean 3	null	2 set-ups		TRUE	-	Ujnt8
<b>13-5* States</b>							
13-51	SL Controller Event	null	2 set-ups		TRUE	-	Ujnt8
13-52	SL Controller Action	null	2 set-ups		TRUE	-	Ujnt8

4.4.13 14-.\* Special Functions

Par. No. #	Parameter description	Default value	4-set-up	FC 302 only	Change during operation	Conversion index	Type
<b>14-0* Inverter Switching</b>							
14-00	Switching Pattern	[1] SFAVM	All set-ups		TRUE	-	Ujnt8
14-01	Switching Frequency	null	All set-ups		TRUE	-	Ujnt8
14-03	Overmodulation	[1] On	All set-ups		FALSE	-	Ujnt8
14-04	PWM Random	[0] Off	All set-ups		TRUE	-	Ujnt8
<b>14-1* Mains On/Off</b>							
14-10	Line Failure	[0] No function	All set-ups		FALSE	-	Ujnt8
14-11	Line Voltage at Line Fault	ExpressionLimit	All set-ups		TRUE	0	Ujnt16
14-12	Function at Mains Imbalance	[0] Trip	All set-ups		TRUE	-	Ujnt8
14-13	Mains Failure Step Factor	1.0 N/A	All set-ups		TRUE	-1	Ujnt8
<b>14-2* Trip Reset</b>							
14-20	Reset Mode	[0] Manual reset	All set-ups		TRUE	-	Ujnt8
14-21	Automatic Restart Time	10 s	All set-ups		TRUE	0	Ujnt16
14-22	Operation Mode	[0] Normal operation	All set-ups		TRUE	-	Ujnt8
14-23	Typecode Setting	null	2 set-ups		FALSE	-	Ujnt8
14-24	Trip Delay at Current Limit	60 s	All set-ups		TRUE	0	Ujnt8
14-25	Trip Delay at Torque Limit	60 s	All set-ups		TRUE	0	Ujnt8
14-26	Trip Delay at Inverter Fault	ExpressionLimit	All set-ups		TRUE	0	Ujnt8
14-28	Production Settings	[0] No action	All set-ups		TRUE	-	Ujnt8
14-29	Service Code	0 N/A	All set-ups		TRUE	0	Int32
<b>14-3* Current Limit Ctrl.</b>							
14-30	Current Lim Contr, Proportional Gain	100 %	All set-ups		FALSE	0	Ujnt16
14-31	Current Lim Contr, Integration Time	0.020 s	All set-ups		FALSE	-3	Ujnt16
14-32	Current Lim Ctrl, Filter Time	1.0 ms	All set-ups		TRUE	-4	Ujnt16
<b>14-4* Energy Optimizing</b>							
14-40	VT Level	66 %	All set-ups		FALSE	0	Ujnt8
14-41	AEO Minimum Magnetization	ExpressionLimit	All set-ups		TRUE	0	Ujnt8
14-42	Minimum AEO Frequency	10 Hz	All set-ups		TRUE	0	Ujnt8
14-43	Motor Cos-Phi	ExpressionLimit	All set-ups		TRUE	-2	Ujnt16
<b>14-5* Environment</b>							
14-50	RFI 1	[1] On	1 set-up	x	FALSE	-	Ujnt8
14-52	Fan Control	[0] Auto	All set-ups		TRUE	-	Ujnt8
14-53	Fan Monitor	[1] Warning	All set-ups		TRUE	-	Ujnt8
14-55	Output Filter	[0] No Filter	All set-ups		FALSE	-	Ujnt8
14-56	Capacitance Output Filter	2.0 uF	All set-ups		FALSE	-7	Ujnt16
14-57	Inductance Output Filter	7.000 mH	All set-ups		FALSE	-6	Ujnt16
14-59	Actual Number of Inverter Units	ExpressionLimit	1 set-up		FALSE	0	Ujnt8
<b>14-7* Compatibility</b>							
14-72	VLT Alarm Word	0 N/A	All set-ups		FALSE	0	Ujnt32
14-73	VLT Warning Word	0 N/A	All set-ups		FALSE	0	Ujnt32
14-74	VLT Ext. Status Word	0 N/A	All set-ups		FALSE	0	Ujnt32
<b>14-8* Options</b>							
14-80	Option Supplied by External 24VDC	[1] Yes	2 set-ups		FALSE	-	Ujnt8

**4.4.14 15- \*\* Drive Information**

Par. No. #	Parameter description	Default value	4-set-up	FC 302 only	Change during operation	Conversion index	Type
<b>15-0* Operating Data</b>							
15-00	Operating Hours	0 h	All set-ups		FALSE	74	Uint32
15-01	Running Hours	0 h	All set-ups		FALSE	74	Uint32
15-02	kWh Counter	0 kWh	All set-ups		FALSE	75	Uint32
15-03	Power-ups	0 N/A	All set-ups		FALSE	0	Uint32
15-04	Over Temps	0 N/A	All set-ups		FALSE	0	Uint16
15-05	Over Volts	0 N/A	All set-ups		FALSE	0	Uint16
15-06	Reset kWh Counter	[0] Do not reset	All set-ups		TRUE	-	Uint8
15-07	Reset Running Hours Counter	[0] Do not reset	All set-ups		TRUE	-	Uint8
<b>15-1* Data Log Settings</b>							
15-10	Logging Source	0	2 set-ups		TRUE	-	Uint16
15-11	Logging Interval	ExpressionLimit	2 set-ups		TRUE	-3	TimD
15-12	Trigger Event	[0] FALSE	1 set-up		TRUE	-	Uint8
15-13	Logging Mode	[0] Log always	2 set-ups		TRUE	-	Uint8
15-14	Samples Before Trigger	50 N/A	2 set-ups		TRUE	0	Uint8
<b>15-2* Historic Log</b>							
15-20	Historic Log: Event	0 N/A	All set-ups		FALSE	0	Uint8
15-21	Historic Log: Value	0 N/A	All set-ups		FALSE	0	Uint32
15-22	Historic Log: Time	0 ms	All set-ups		FALSE	-3	Uint32
<b>15-3* Fault Log</b>							
15-30	Fault Log: Error Code	0 N/A	All set-ups		FALSE	0	Uint8
15-31	Fault Log: Value	0 N/A	All set-ups		FALSE	0	Int16
15-32	Fault Log: Time	0 s	All set-ups		FALSE	0	Uint32
<b>15-4* Drive Identification</b>							
15-40	FC Type	0 N/A	All set-ups		FALSE	0	VisStr[6]
15-41	Power Section	0 N/A	All set-ups		FALSE	0	VisStr[20]
15-42	Voltage	0 N/A	All set-ups		FALSE	0	VisStr[20]
15-43	Software Version	0 N/A	All set-ups		FALSE	0	VisStr[5]
15-44	Ordered Typecode String	0 N/A	All set-ups		FALSE	0	VisStr[40]
15-45	Actual Typecode String	0 N/A	All set-ups		FALSE	0	VisStr[40]
15-46	Adj Freq Dr Ordering No.	0 N/A	All set-ups		FALSE	0	VisStr[8]
15-47	Power Card Ordering No.	0 N/A	All set-ups		FALSE	0	VisStr[8]
15-48	LCP ID Num.	0 N/A	All set-ups		FALSE	0	VisStr[20]
15-49	SW ID Control Card	0 N/A	All set-ups		FALSE	0	VisStr[20]
15-50	SW ID Power Card	0 N/A	All set-ups		FALSE	0	VisStr[20]
15-51	Adj Freq Dr Serial No.	0 N/A	All set-ups		FALSE	0	VisStr[10]
15-53	Power Card Serial Number	0 N/A	All set-ups		FALSE	0	VisStr[19]

Par. No. #	Parameter description	Default value	4-set-up	FC 302 only	Change during op- eration	Conver- sion index	Type
<b>15-6* Option Ident</b>							
15-60	Option Mounted	0 N/A	All set-ups		FALSE	0	VisStr[30]
15-61	Option SW Version	0 N/A	All set-ups		FALSE	0	VisStr[20]
15-62	Option Ordering No	0 N/A	All set-ups		FALSE	0	VisStr[8]
15-63	Option Serial No	0 N/A	All set-ups		FALSE	0	VisStr[18]
15-70	Option in Slot A	0 N/A	All set-ups		FALSE	0	VisStr[30]
15-71	Slot A Option SW Version	0 N/A	All set-ups		FALSE	0	VisStr[20]
15-72	Option in Slot B	0 N/A	All set-ups		FALSE	0	VisStr[30]
15-73	Slot B Option SW Version	0 N/A	All set-ups		FALSE	0	VisStr[20]
15-74	Option in Slot C0	0 N/A	All set-ups		FALSE	0	VisStr[30]
15-75	Slot C0 Option SW Version	0 N/A	All set-ups		FALSE	0	VisStr[20]
15-76	Option in Slot C1	0 N/A	All set-ups		FALSE	0	VisStr[30]
15-77	Slot C1 Option SW Version	0 N/A	All set-ups		FALSE	0	VisStr[20]
<b>15-9* Parameter Info</b>							
15-92	Defined Parameters	0 N/A	All set-ups		FALSE	0	Uint16
15-93	Modified Parameters	0 N/A	All set-ups		FALSE	0	Uint16
15-98	Drive Identification	0 N/A	All set-ups		FALSE	0	VisStr[40]
15-99	Parameter Metadata	0 N/A	All set-ups		FALSE	0	Uint16

### 4.4.15 16- \*\* Data Readouts

Par. No. #	Parameter description	Default value	4-set-up	FC 302 only	Change during operation	Conversion index	Type
<b>16-0* General Status</b>							
16-00	Control Word	0 N/A	All set-ups		FALSE	0	V2
16-01	Reference [Unit]	0.000 ReferenceFeedbackUnit	All set-ups		FALSE	-3	Int32
16-02	Reference %	0.0 %	All set-ups		FALSE	-1	Int16
16-03	Status Word	0 N/A	All set-ups		FALSE	0	V2
16-05	Main Actual Value [%]	0.00 %	All set-ups		FALSE	-2	N2
16-09	Custom Readout	0.00 CustomReadoutUnit	All set-ups		FALSE	-2	Int32
<b>16-1* Motor Status</b>							
16-10	Power [kW]	0.00 kW	All set-ups		FALSE	1	Int32
16-11	Power [hp]	0.00 hp	All set-ups		FALSE	-2	Int32
16-12	Motor voltage	0.0 V	All set-ups		FALSE	-1	Uint16
16-13	Frequency	0.0 Hz	All set-ups		FALSE	-1	Uint16
16-14	Motor Current	0.00 A	All set-ups		FALSE	-2	Int32
16-15	Frequency [%]	0.00 %	All set-ups		FALSE	-2	N2
16-16	Torque [Nm]	0.0 Nm	All set-ups		FALSE	-1	Int16
16-17	Speed [RPM]	0 RPM	All set-ups		FALSE	67	Int32
16-18	Motor Thermal	0 %	All set-ups		FALSE	0	Uint8
16-19	KTY sensor temperature	0 °C	All set-ups		FALSE	100	Int16
16-20	Motor Angle	0 N/A	All set-ups		TRUE	0	Uint16
16-22	Torque [%]	0 %	All set-ups		FALSE	0	Int16
16-25	Torque [Nm] High	0.0 Nm	All set-ups		FALSE	-1	Int32
<b>16-3* Drive Status</b>							
16-30	DC Link Voltage	0 V	All set-ups		FALSE	0	Uint16
16-32	Brake Energy /s	0.000 kW	All set-ups		FALSE	0	Uint32
16-33	Brake Energy /2 min	0.000 kW	All set-ups		FALSE	0	Uint32
16-34	Heatsink Temp.	0 °C	All set-ups		FALSE	100	Uint8
16-35	Inverter Thermal	0 %	All set-ups		FALSE	0	Uint8
16-36	Inv. Nom. Current	ExpressionLimit	All set-ups		FALSE	-2	Uint32
16-37	Inv. Max. Current	ExpressionLimit	All set-ups		FALSE	-2	Uint32
16-38	SL Controller State	0 N/A	All set-ups		FALSE	0	Uint8
16-39	Control Card Temp.	0 °C	All set-ups		FALSE	100	Uint8
16-40	Logging Buffer Full	[0] No	All set-ups		TRUE	-	Uint8
<b>16-5* Ref. &amp; Feedb.</b>							
16-50	External Reference	0.0 N/A	All set-ups		FALSE	-1	Int16
16-51	Pulse Reference	0.0 N/A	All set-ups		FALSE	-1	Int16
16-52	Feedback [Unit]	0.000 ReferenceFeedbackUnit	All set-ups		FALSE	-3	Int32
16-53	Digi Pot Reference	0.00 N/A	All set-ups		FALSE	-2	Int16

Par. No. #	Parameter description	Default value	4-set-up	FC 302 only	Change during operation	Conversion index	Type
<b>16-6* Inputs &amp; Outputs</b>							
16-60	Digital Input	0 N/A	All set-ups		FALSE	0	Uint16
16-61	Terminal 53 Switch Setting	[0] Current	All set-ups		FALSE	-	Uint8
16-62	Analog Input 53	0.000 N/A	All set-ups		FALSE	-3	Int32
16-63	Terminal 54 Switch Setting	[0] Current	All set-ups		FALSE	-	Uint8
16-64	Analog Input 54	0.000 N/A	All set-ups		FALSE	-3	Int32
16-65	Analog Output 42 [mA]	0.000 N/A	All set-ups		FALSE	-3	Int16
16-66	Digital Output [bin]	0 N/A	All set-ups		FALSE	0	Int16
16-67	Freq. Input #29 [Hz]	0 N/A	All set-ups	x	FALSE	0	Int32
16-68	Freq. Input #33 [Hz]	0 N/A	All set-ups		FALSE	0	Int32
16-69	Pulse Output #27 [Hz]	0 N/A	All set-ups		FALSE	0	Int32
16-70	Pulse Output #29 [Hz]	0 N/A	All set-ups	x	FALSE	0	Int32
16-71	Relay Output [bin]	0 N/A	All set-ups		FALSE	0	Int16
16-72	Counter A	0 N/A	All set-ups		TRUE	0	Int32
16-73	Counter B	0 N/A	All set-ups		TRUE	0	Int32
16-74	Prec. Stop Counter	0 N/A	All set-ups		TRUE	0	Uint32
16-75	Analog In X30/11	0.000 N/A	All set-ups		FALSE	-3	Int32
16-76	Analog In X30/12	0.000 N/A	All set-ups		FALSE	-3	Int32
16-77	Analog Out X30/8 [mA]	0.000 N/A	All set-ups		FALSE	-3	Int16
16-78	Analog Out X45/1 [mA]	0.000 N/A	All set-ups		FALSE	-3	Int16
16-79	Analog Out X45/3 [mA]	0.000 N/A	All set-ups		FALSE	-3	Int16
<b>16-8* Fieldbus &amp; FC Port</b>							
16-80	Fieldbus CTW 1	0 N/A	All set-ups		FALSE	0	V2
16-82	Fieldbus REF 1	0 N/A	All set-ups		FALSE	0	N2
16-84	Comm. Option Status	0 N/A	All set-ups		FALSE	0	V2
16-85	FC Port CTW 1	0 N/A	All set-ups		FALSE	0	V2
16-86	FC Port REF 1	0 N/A	All set-ups		FALSE	0	N2
<b>16-9* Diagnosis Readouts</b>							
16-90	Alarm Word	0 N/A	All set-ups		FALSE	0	Uint32
16-91	Alarm word 2	0 N/A	All set-ups		FALSE	0	Uint32
16-92	Warning Word	0 N/A	All set-ups		FALSE	0	Uint32
16-93	Warning word 2	0 N/A	All set-ups		FALSE	0	Uint32
16-94	Ext. Status Word	0 N/A	All set-ups		FALSE	0	Uint32



### 4.4.16 17-\*\* Motor Feedb.Option

Par. No. #	Parameter description	Default value	4-set-up	FC 302 only	Change during operation	Conversion index	Type
<b>17-1* Inc. Enc. Interface</b>							
17-10	Signal Type	[1] TTL (5V, RS422)	All set-ups		FALSE	-	Ujnt8
17-11	Resolution (PPR)	1024 N/A	All set-ups		FALSE	0	Ujnt16
<b>17-2* Abs. Enc. Interface</b>							
17-20	Protocol Selection	[0] None	All set-ups		FALSE	-	Ujnt8
17-21	Resolution (Positions/Rev)	ExpressionLimit	All set-ups		FALSE	0	Ujnt32
17-24	SSI Data Length	13 N/A	All set-ups		FALSE	0	Ujnt8
17-25	Clock Rate	ExpressionLimit	All set-ups		FALSE	3	Ujnt16
17-26	SSI Data Format	[0] Gray code	All set-ups		FALSE	-	Ujnt8
17-34	HIPERFACE Baud rate	[4] 9600	All set-ups		FALSE	-	Ujnt8
<b>17-5* Resolver Interface</b>							
17-50	Poles	2 N/A	1 set-up		FALSE	0	Ujnt8
17-51	Input Voltage	7.0 V	1 set-up		FALSE	-1	Ujnt8
17-52	Input Frequency	10.0 KHz	1 set-up		FALSE	2	Ujnt8
17-53	Transformation Ratio	0.5 N/A	1 set-up		FALSE	-1	Ujnt8
17-59	Resolver Interface	[0] Disabled	All set-ups		FALSE	-	Ujnt8
<b>17-6* Monitoring and App.</b>							
17-60	Feedback Direction	[0] Clockwise	All set-ups		FALSE	-	Ujnt8
17-61	Feedback Signal Monitoring	[1] Warning	All set-ups		TRUE	-	Ujnt8

4.4.17 32-.\*.\* MCO Basic Settings

Par. No. #	Parameter description	Default value	4-set-up	FC 302 only	Change during operation	Conversion index	Type
<b>32-0* Encoder 2</b>							
32-00	Incremental Signal Type	[1] TTL (5V, RS4222)	2 set-ups		TRUE	-	Uint8
32-01	Incremental Resolution	1024 N/A	2 set-ups		TRUE	0	Uint32
32-02	Absolute Protocol	[0] None	2 set-ups		TRUE	-	Uint8
32-03	Absolute Resolution	8192 N/A	2 set-ups		TRUE	0	Uint32
32-04	Absolute Encoder Data Length	25 N/A	2 set-ups		TRUE	0	Uint8
32-05	Absolute Encoder Clock Frequency	262.000 kHz	2 set-ups		TRUE	0	Uint32
32-06	Absolute Encoder Clock Generation	[1] On	2 set-ups		TRUE	-	Uint8
32-07	Absolute Encoder Cable Length	0 m	2 set-ups		TRUE	0	Uint16
32-08	Encoder Monitoring	[0] Off	2 set-ups		TRUE	-	Uint8
32-09	Rotational Direction	[1] No action	2 set-ups		TRUE	-	Uint8
32-10	User Unit Denominator	1 N/A	2 set-ups		TRUE	0	Uint32
32-11	User Unit Numerator	1 N/A	2 set-ups		TRUE	0	Uint32
<b>32-3* Encoder 1</b>							
32-30	Incremental Signal Type	[1] TTL (5V, RS4222)	2 set-ups		TRUE	-	Uint8
32-31	Incremental Resolution	1024 N/A	2 set-ups		TRUE	0	Uint32
32-32	Absolute Protocol	[0] None	2 set-ups		TRUE	-	Uint8
32-33	Absolute Resolution	8192 N/A	2 set-ups		TRUE	0	Uint32
32-34	Absolute Encoder Data Length	25 N/A	2 set-ups		TRUE	0	Uint8
32-35	Absolute Encoder Clock Frequency	262.000 kHz	2 set-ups		TRUE	0	Uint32
32-36	Absolute Encoder Clock Generation	[1] On	2 set-ups		TRUE	-	Uint8
32-37	Absolute Encoder Cable Length	0 m	2 set-ups		TRUE	0	Uint16
32-38	Encoder Monitoring	[0] Off	2 set-ups		TRUE	-	Uint8
32-39	Encoder Termination	[1] On	2 set-ups		TRUE	-	Uint8
<b>32-5* Feedback Source</b>							
32-50	Source Slave	[2] Encoder 2	2 set-ups		TRUE	-	Uint8
32-51	MCO 302 Last Will	[1] Trip	2 set-ups		TRUE	-	Uint8
<b>32-6* PID Controller</b>							
32-60	Proportional factor	30 N/A	2 set-ups		TRUE	0	Uint32
32-61	Derivative factor	0 N/A	2 set-ups		TRUE	0	Uint32
32-62	Integral factor	0 N/A	2 set-ups		TRUE	0	Uint32
32-63	Limit Value for Integral Sum	1000 N/A	2 set-ups		TRUE	0	Uint16
32-64	PID Bandwidth	1000 N/A	2 set-ups		TRUE	0	Uint16
32-65	Velocity Feed-Forward	0 N/A	2 set-ups		TRUE	0	Uint32
32-66	Acceleration Feed-Forward	0 N/A	2 set-ups		TRUE	0	Uint32
32-67	Max. Tolerated Position Error	20000 N/A	2 set-ups		TRUE	0	Uint32
32-68	Reverse Behavior for Slave	[0] Reversing allowed	2 set-ups		TRUE	-	Uint8
32-69	Sampling Time for PID Control	1 ms	2 set-ups		TRUE	-3	Uint16
32-70	Scan Time for Profile Generator	1 ms	2 set-ups		TRUE	-3	Uint8
32-71	Size of the Control Window (Activation)	0 N/A	2 set-ups		TRUE	0	Uint32
32-72	Size of the Control Window (Deactiv.)	0 N/A	2 set-ups		TRUE	0	Uint32
<b>32-8* Velocity &amp; Accel.</b>							
32-80	Maximum Velocity (Encoder)	1500 RPM	2 set-ups		TRUE	67	Uint32
32-81	Shortest Ramp	1.000 s	2 set-ups		TRUE	-3	Uint32
32-82	Ramp Type	[0] Linear	2 set-ups		TRUE	-	Uint8
32-83	Velocity Resolution	100 N/A	2 set-ups		TRUE	0	Uint32
32-84	Default Velocity	50 N/A	2 set-ups		TRUE	0	Uint32
32-85	Default Acceleration	50 N/A	2 set-ups		TRUE	0	Uint32
<b>32-9* Development</b>							
32-90	Debug Source	[0] Controlcard	2 set-ups		TRUE	-	Uint8

4.4.18 33-\*\* MCO Adv. Settings

Par. No. #	Parameter description	Default value	4-set-up	FC 302 only	Change during operation	Conversion index	Type
<b>33-0* Home Motion</b>							
33-00	Force HOME	[0] Home not forced	2 set-ups		TRUE	-	Uint8
33-01	Zero Point Offset from Home Pos.	0 N/A	2 set-ups		TRUE	0	Int32
33-02	Ramp for Home Motion	10 N/A	2 set-ups		TRUE	0	Uint32
33-03	Velocity of Home Motion	10 N/A	2 set-ups		TRUE	0	Int32
33-04	Behavior during Home Motion	[0] Reverse and index	2 set-ups		TRUE	-	Uint8
<b>33-1* Synchronization</b>							
33-10	Synchronization Factor Master (M:S)	1 N/A	2 set-ups		TRUE	0	Int32
33-11	Synchronization Factor Slave (M:S)	1 N/A	2 set-ups		TRUE	0	Int32
33-12	Position Offset for Synchronization	0 N/A	2 set-ups		TRUE	0	Int32
33-13	Accuracy Window for Position Sync.	1000 N/A	2 set-ups		TRUE	0	Int32
33-14	Relative Slave Velocity Limit	0 %	2 set-ups		TRUE	0	Uint8
33-15	Marker Number for Master	1 N/A	2 set-ups		TRUE	0	Uint16
33-16	Marker Number for Slave	1 N/A	2 set-ups		TRUE	0	Uint16
33-17	Master Marker Distance	4096 N/A	2 set-ups		TRUE	0	Uint32
33-18	Slave Marker Distance	4096 N/A	2 set-ups		TRUE	0	Uint32
33-19	Master Marker Type	[0] Encoder Z positive	2 set-ups		TRUE	-	Uint8
33-20	Slave Marker Type	[0] Encoder Z positive	2 set-ups		TRUE	-	Uint8
33-21	Master Marker Tolerance Window	0 N/A	2 set-ups		TRUE	0	Uint32
33-22	Slave Marker Tolerance Window	0 N/A	2 set-ups		TRUE	0	Uint32
33-23	Start Behavior for Marker Sync	[0] Start Function 1	2 set-ups		TRUE	-	Uint16
33-24	Marker Number for Fault	10 N/A	2 set-ups		TRUE	0	Uint16
33-25	Marker Number for Ready	1 N/A	2 set-ups		TRUE	0	Uint16
33-26	Velocity Filter	0 us	2 set-ups		TRUE	-6	Int32
33-27	Offset Filter Time	0 ms	2 set-ups		TRUE	-3	Uint32
33-28	Marker Filter Configuration	[0] Marker filter 1	2 set-ups		TRUE	-	Uint8
33-29	Filter Time for Marker Filter	0 ms	2 set-ups		TRUE	-3	Int32
33-30	Maximum Marker Correction	0 N/A	2 set-ups		TRUE	0	Uint32
33-31	Synchronization Type	[0] Standard	2 set-ups		TRUE	-	Uint8
<b>33-4* Limit Handling</b>							
33-40	Behavior at End Limit Switch	[0] Call error handler	2 set-ups		TRUE	-	Uint8
33-41	Negative Software End Limit	-500000 N/A	2 set-ups		TRUE	0	Int32
33-42	Positive Software End Limit	500000 N/A	2 set-ups		TRUE	0	Int32
33-43	Negative Software End Limit Active	[0] Inactive	2 set-ups		TRUE	-	Uint8
33-44	Positive Software End Limit Active	[0] Inactive	2 set-ups		TRUE	-	Uint8
33-45	Time in Target Window	0 ms	2 set-ups		TRUE	-3	Uint8
33-46	Target Window LimitValue	1 N/A	2 set-ups		TRUE	0	Uint16
33-47	Size of Target Window	0 N/A	2 set-ups		TRUE	0	Uint16

Par. No. #	Parameter description	Default value	4-set-up	FC 302 only	Change during operation	Conversion index	Type
<b>33-5* I/O Configuration</b>							
33-50	Terminal X57/1 Digital Input	[0] No function	2 set-ups		TRUE	-	Uint8
33-51	Terminal X57/2 Digital Input	[0] No function	2 set-ups		TRUE	-	Uint8
33-52	Terminal X57/3 Digital Input	[0] No function	2 set-ups		TRUE	-	Uint8
33-53	Terminal X57/4 Digital Input	[0] No function	2 set-ups		TRUE	-	Uint8
33-54	Terminal X57/5 Digital Input	[0] No function	2 set-ups		TRUE	-	Uint8
33-55	Terminal X57/6 Digital Input	[0] No function	2 set-ups		TRUE	-	Uint8
33-56	Terminal X57/7 Digital Input	[0] No function	2 set-ups		TRUE	-	Uint8
33-57	Terminal X57/8 Digital Input	[0] No function	2 set-ups		TRUE	-	Uint8
33-58	Terminal X57/9 Digital Input	[0] No function	2 set-ups		TRUE	-	Uint8
33-59	Terminal X57/10 Digital Input	[0] No function	2 set-ups		TRUE	-	Uint8
33-60	Terminal X59/1 and X59/2 Mode	[1] Output	2 set-ups		FALSE	-	Uint8
33-61	Terminal X59/1 Digital Input	[0] No function	2 set-ups		TRUE	-	Uint8
33-62	Terminal X59/2 Digital Input	[0] No function	2 set-ups		TRUE	-	Uint8
33-63	Terminal X59/1 Digital Output	[0] No function	2 set-ups		TRUE	-	Uint8
33-64	Terminal X59/2 Digital Output	[0] No function	2 set-ups		TRUE	-	Uint8
33-65	Terminal X59/3 Digital Output	[0] No function	2 set-ups		TRUE	-	Uint8
33-66	Terminal X59/4 Digital Output	[0] No function	2 set-ups		TRUE	-	Uint8
33-67	Terminal X59/5 Digital Output	[0] No function	2 set-ups		TRUE	-	Uint8
33-68	Terminal X59/6 Digital Output	[0] No function	2 set-ups		TRUE	-	Uint8
33-69	Terminal X59/7 Digital Output	[0] No function	2 set-ups		TRUE	-	Uint8
33-70	Terminal X59/8 Digital Output	[0] No function	2 set-ups		TRUE	-	Uint8
<b>33-8* Global Parameters</b>							
33-80	Activated Program Number	-1 N/A	2 set-ups		TRUE	0	Int8
33-81	Power-up State	[1] Motor ON	2 set-ups		TRUE	-	Uint8
33-82	Drive Status Monitoring	[1] On	2 set-ups		TRUE	-	Uint8
33-83	Behavior After Error	[0] Coast	2 set-ups		TRUE	-	Uint8
33-84	Behavior after Esc.	[0] Controlled stop	2 set-ups		TRUE	-	Uint8
33-85	MCO Supplied by External 24VDC	[0] No	2 set-ups		TRUE	-	Uint8
33-86	Terminal at alarm	[0] Relay 1	2 set-ups		TRUE	-	Uint8
33-87	Terminal state at alarm	[0] Do nothing	2 set-ups		TRUE	-	Uint8
33-88	Status word at alarm	0 N/A	2 set-ups		TRUE	0	Uint16

**4.4.19 34- \*\* MCO Data Readouts**

Par. No. #	Parameter description	Default value	4-set-up	FC 302 only	Change during operation	Conversion index	Type
<b>34-0* PCD Write Par.</b>							
34-01	PCD 1 Write to MCO	0 N/A	All set-ups		TRUE	0	Uint16
34-02	PCD 2 Write to MCO	0 N/A	All set-ups		TRUE	0	Uint16
34-03	PCD 3 Write to MCO	0 N/A	All set-ups		TRUE	0	Uint16
34-04	PCD 4 Write to MCO	0 N/A	All set-ups		TRUE	0	Uint16
34-05	PCD 5 Write to MCO	0 N/A	All set-ups		TRUE	0	Uint16
34-06	PCD 6 Write to MCO	0 N/A	All set-ups		TRUE	0	Uint16
34-07	PCD 7 Write to MCO	0 N/A	All set-ups		TRUE	0	Uint16
34-08	PCD 8 Write to MCO	0 N/A	All set-ups		TRUE	0	Uint16
34-09	PCD 9 Write to MCO	0 N/A	All set-ups		TRUE	0	Uint16
34-10	PCD 10 Write to MCO	0 N/A	All set-ups		TRUE	0	Uint16
<b>34-2* PCD Read Par.</b>							
34-21	PCD 1 Read from MCO	0 N/A	All set-ups		TRUE	0	Uint16
34-22	PCD 2 Read from MCO	0 N/A	All set-ups		TRUE	0	Uint16
34-23	PCD 3 Read from MCO	0 N/A	All set-ups		TRUE	0	Uint16
34-24	PCD 4 Read from MCO	0 N/A	All set-ups		TRUE	0	Uint16
34-25	PCD 5 Read from MCO	0 N/A	All set-ups		TRUE	0	Uint16
34-26	PCD 6 Read from MCO	0 N/A	All set-ups		TRUE	0	Uint16
34-27	PCD 7 Read from MCO	0 N/A	All set-ups		TRUE	0	Uint16
34-28	PCD 8 Read from MCO	0 N/A	All set-ups		TRUE	0	Uint16
34-29	PCD 9 Read from MCO	0 N/A	All set-ups		TRUE	0	Uint16
34-30	PCD 10 Read from MCO	0 N/A	All set-ups		TRUE	0	Uint16
<b>34-4* Inputs &amp; Outputs</b>							
34-40	Digital Inputs	0 N/A	All set-ups		TRUE	0	Uint16
34-41	Digital Outputs	0 N/A	All set-ups		TRUE	0	Uint16
<b>34-5* Process Data</b>							
34-50	Actual Position	0 N/A	All set-ups		TRUE	0	Int32
34-51	Commanded Position	0 N/A	All set-ups		TRUE	0	Int32
34-52	Actual Master Position	0 N/A	All set-ups		TRUE	0	Int32
34-53	Slave Index Position	0 N/A	All set-ups		TRUE	0	Int32
34-54	Master Index Position	0 N/A	All set-ups		TRUE	0	Int32
34-55	Curve Position	0 N/A	All set-ups		TRUE	0	Int32
34-56	Track Error	0 N/A	All set-ups		TRUE	0	Int32
34-57	Synchronizing Error	0 N/A	All set-ups		TRUE	0	Int32
34-58	Actual Velocity	0 N/A	All set-ups		TRUE	0	Int32
34-59	Actual Master Velocity	0 N/A	All set-ups		TRUE	0	Int32
34-60	Synchronizing Status	0 N/A	All set-ups		TRUE	0	Int32
34-61	Axis Status	0 N/A	All set-ups		TRUE	0	Int32
34-62	Program Status	0 N/A	All set-ups		TRUE	0	Int32
34-64	MCO 302 Status	0 N/A	All set-ups		TRUE	0	Uint16
34-65	MCO 302 Control	0 N/A	All set-ups		TRUE	0	Uint16
<b>34-7* Diagnosis readouts</b>							
34-70	MCO Alarm Word 1	0 N/A	All set-ups		FALSE	0	Uint32
34-71	MCO Alarm Word 2	0 N/A	All set-ups		FALSE	0	Uint32



## 5 General Specifications

### Line power supply (L1, L2, L3):

Supply voltage	200–240 V ±10%
Supply voltage	FC 301: 380–480 V / FC 302: 380–500 V ±10%
Supply voltage	FC 302: 525–690 V ±10%
Supply frequency	50/60 Hz
Max. imbalance temporary between line phases	3.0% of rated supply voltage
True Power Factor ( $\lambda$ )	≥ 0.9 nominal at rated load
Displacement Power Factor (cos $\phi$ )	near unity (> 0.98)
Switching on input supply L1, L2, L3 (power-ups) ≤10 hp [7.5 kW]	maximum 2 times/min.
Switching on input supply L1, L2, L3 (power-ups) 15–100 hp [11–75 kW]	maximum 1 time/min.
Switching on input supply L1, L2, L3 (power-ups) ≥ 125 hp [90 kW]	maximum 1 time/2 min.
Environment according to EN60664-1	overvoltage category III/pollution degree 2

*The unit is suitable for use on a circuit capable of delivering not more than 100,000 RMS symmetrical amperes, 240/500/600/ 690 V maximum.*

### Motor output (U, V, W):

Output voltage	0–100% of supply voltage
Output frequency (0.33–10 hp [0.25–75 kW])	FC 301: 0.2–1,000 Hz / FC 302: 0–1,000 Hz
Output frequency (125–1,350 hp [90–1,000 kW])	0–800* Hz
Output frequency in flux mode (FC 302 only)	0–300 Hz
Switching on output	Unlimited
Ramp times	0.01–3,600 sec.

*\* Voltage and power dependent*

### Torque characteristics:

Starting torque (Constant torque)	maximum 160% for 60 sec.*
Starting torque	maximum 180% up to 0.5 sec.*
Overload torque (Constant torque)	maximum 160% for 60 sec.*
Starting torque (Variable torque)	maximum 110% for 60 sec.*
Overload torque (Variable torque)	maximum 110% for 60 sec.

*\*Percentage relates to the nominal torque.*

### Digital inputs:

Programmable digital inputs	FC 301: 4 (5) / FC 302: 4 (6)
Terminal number	18, 19, 27 <sup>1)</sup> , 29 <sup>1)</sup> , 32, 33,
Logic	PNP or NPN
Voltage level	0–24 V DC
Voltage level, logic '0' PNP	< 5 V DC
Voltage level, logic '1' PNP	> 10 V DC
Voltage level, logic '0' NPN <sup>2)</sup>	> 19 V DC
Voltage level, logic '1' NPN <sup>2)</sup>	< 14 V DC
Maximum voltage on input	28 V DC
Pulse frequency ranges	0–110 kHz
(Duty cycle) Min. pulse width	4.5 ms
Input resistance, R <sub>i</sub>	approximately 4 kΩ

Safe stop Terminal 37<sup>3)</sup> (Terminal 37 is fixed PNP logic):

Voltage level	0–24 V DC
Voltage level, logic'0' PNP	< 4 V DC
Voltage level, logic'1' PNP	>20 V DC
Nominal input current at 24 V	50 mA rms
Nominal input current at 20 V	60 mA rms
Input capacitance	400 nF

All digital inputs are galvanically isolated from the supply voltage (PELV) and other high-voltage terminals.

1) Terminals 27 and 29 can also be programmed as output.

2) Except safe stop input Terminal 37.

3) Terminal 37 is only available in FC 302 and FC 301 A1 with Safe Stop. It can only be used as safe stop input. Terminal 37 is suitable for category 3 installations in accordance with EN 954-1 (safe stop according to category 0 EN 60204-1), and as required by the EU Machinery Directive 98/37/EC. Terminal 37 and the safe stop function are designed in accordance with EN 60204-1, EN 50178, EN 61800-2, EN 61800-3 and EN 954-1. For correct and safe use of the Safe Stop function, follow the related information and instructions in the Design Guide.

4) FC 302 only.

Analog inputs:

Number of analog inputs	2
Terminal number	53, 54
Modes	Voltage or current
Mode select	Switch S201 and switch S202
Voltage mode	Switch S201/switch S202 = OFF (U)
Voltage level	FC 301: 0 to + 10/ FC 302: -10 to +10 V (scalable)
Input resistance, $R_i$	approx. 10 k $\Omega$
Max. voltage	$\pm$ 20 V
Current mode	Switch S201/switch S202 = ON (I)
Current level	0/4–20 mA (scaleable)
Input resistance, $R_i$	approx. 200 $\Omega$
Max. current	30 mA
Resolution for analog inputs	10 bit (+ sign)
Accuracy of analog inputs	Max. error 0.5% of full scale
Bandwidth	FC 301: 20 Hz/ FC 302: 100 Hz

The analog inputs are galvanically isolated from the supply voltage (PELV) and other high-voltage terminals.

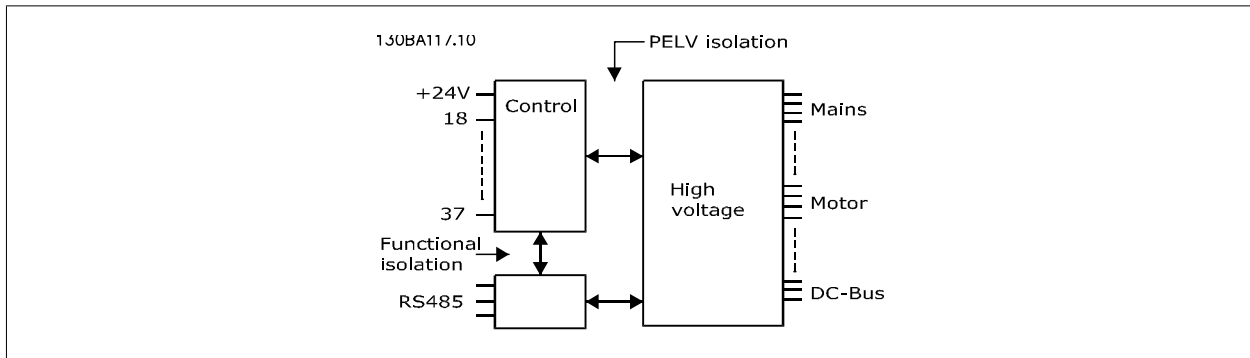



Pulse/encoder inputs:

Programmable pulse/encoder inputs	2/1
Terminal number pulse/encoder	29 <sup>1)</sup> , 33 <sup>2)</sup> / 32 <sup>3)</sup> , 33 <sup>3)</sup>
Max. frequency at terminal 29, 32, 33	110 kHz (push-pull driven)
Max. frequency at terminal 29, 32, 33	5 kHz (open collector)
Min. frequency at terminal 29, 32, 33	4 Hz
Voltage level	see section on Digital input
Maximum voltage on input	28 V DC
Input resistance, R <sub>i</sub>	approximately 4 kΩ
Pulse input accuracy (0.1–1 kHz)	Max. error: 0.1% of full scale
Encoder input accuracy (1–110 kHz)	Max. error: 0.05 % of full scale

*The pulse and encoder inputs (terminals 29, 32, 33) are galvanically isolated from the supply voltage (PELV) and other high-voltage terminals.*

- 1) FC 302 only
- 2) Pulse inputs are 29 and 33
- 3) Encoder inputs: 32 = A, and 33 = B

Digital output:

Programmable digital/pulse outputs	2
Terminal number	27, 29 <sup>1)</sup>
Voltage level at digital/frequency output	0-24 V
Max. output current (sink or source)	40 mA
Max. load at frequency output	1 kΩ
Max. capacitive load at frequency output	10 nF
Minimum output frequency at frequency output	0 Hz
Maximum output frequency at frequency output	32 kHz
Accuracy of frequency output	Max. error: 0.1% of full scale
Resolution of frequency outputs	12 bit

1) Terminal 27 and 29 can also be programmed as input.

*The digital output is galvanically isolated from the supply voltage (PELV) and other high-voltage terminals.*

Analog output:

Number of programmable analog outputs	1
Terminal number	42
Current range at analog output	0/4–20 mA
Max. load GND - analog output	500 Ω
Accuracy on analog output	Max. error: 0.5 % of full scale
Resolution on analog output	12 bit

*The analog output is galvanically isolated from the supply voltage (PELV) and other high-voltage terminals.*

Control card, 24 V DC output:

Terminal number	12, 13
Output voltage	24 V +1, -3 V
Max. load	FC 301: 130 mA/ FC 302: 200 mA

*The 24 V DC supply is galvanically isolated from the supply voltage (PELV), but has the same potential as the analog and digital inputs and outputs.*

Control card, 10 V DC output:

Terminal number	50
Output voltage	10.5 V ±0.5 V
Max. load	15 mA

*The 10 V DC supply is galvanically isolated from the supply voltage (PELV) and other high-voltage terminals.*

Control card, RS-485 serial communication:

Terminal number	68 (P,TX+, RX+), 69 (N,TX-, RX-)
Terminal number 61	Common for terminals 68 and 69

*The RS-485 serial communication circuit is functionally separated from other central circuits and galvanically isolated from the supply voltage (PELV).*

## Control card, USB serial communication:

USB standard	1.1 (Full speed)
USB plug	USB type B "device" plug

Connection to PC is carried out via a standard host/device USB cable.

The USB connection is galvanically isolated from the supply voltage (PELV) and other high-voltage terminals.

The USB ground connection is not galvanically isolated from protection ground. Use only an isolated laptop as PC connection to the USB connector on the adjustable frequency drive.

## Relay outputs:

Programmable relay outputs	FC 301 ≤ 10 hp [7.5 kW]: 1 / FC 302 all kW: 2
Relay 01 Terminal number	1-3 (break), 1-2 (make)
Max. terminal load (AC-1) <sup>1)</sup> on 1-3 (NC), 1-2 (NO) (Resistive load)	240 V AC, 2 A
Max. terminal load (AC-15) <sup>1)</sup> (Inductive load @ cosφ 0.4)	240 V AC, 0.2 A
Max. terminal load (DC-1) <sup>1)</sup> on 1-2 (NO), 1-3 (NC) (Resistive load)	60 V DC, 1A
Max. terminal load (DC-13) <sup>1)</sup> (Inductive load)	24 V DC, 0.1A
Relay 02 (FC 302 only) Terminal number	4-6 (break), 4-5 (make)
Max. terminal load (AC-1) <sup>1)</sup> on 4-5 (NO) (Resistive load) <sup>2)3)</sup> Overvoltage cat. II	400 V AC, 2 A
Max. terminal load (AC-15) <sup>1)</sup> on 4-5 (NO) (Inductive load @ cosφ 0.4)	240 V AC, 0.2 A
Max. terminal load (DC-1) <sup>1)</sup> on 4-5 (NO) (Resistive load)	80 V DC, 2 A
Max. terminal load (DC-13) <sup>1)</sup> on 4-5 (NO) (Inductive load)	24 V DC, 0.1A
Max. terminal load (AC-1) <sup>1)</sup> on 4-6 (NC) (Resistive load)	240 V AC, 2 A
Max. terminal load (AC-15) <sup>1)</sup> on 4-6 (NC) (Inductive load @ cosφ 0.4)	240 V AC, 0.2 A
Max. terminal load (DC-1) <sup>1)</sup> on 4-6 (NC) (Resistive load)	50 V DC, 2 A
Max. terminal load (DC-13) <sup>1)</sup> on 4-6 (NC) (Inductive load)	24 V DC, 0.1 A
Min. terminal load on 1-3 (NC), 1-2 (NO), 4-6 (NC), 4-5 (NO)	24 V DC 10 mA, 24 V AC 20 mA
Environment according to EN 60664-1	overvoltage category III/pollution degree 2

1) IEC 60947 part 4 and 5

The relay contacts are galvanically isolated from the rest of the circuit by reinforced isolation (PELV).

2) Overvoltage Category II

3) UL applications 300 V AC 2 A

## Cable lengths and cross-sections for control cables\*:

Max. motor cable length, shielded	FC 301: 164 ft [50 m] / FC 301 (A1): 25 ft [25 m]/ FC 302: 492 ft [150 m]
Max. motor cable length, unshielded	FC 301: 246 ft [75 m]/ FC 301 (A1): 164 ft [50 m]/ FC 302: 984 ft [300 m]
Maximum cross-section to control terminals, flexible/rigid wire without cable end sleeves	0.0023 in <sup>2</sup> [1.5 mm <sup>2</sup> ]/16 AWG
Maximum cross-section to control terminals, flexible wire with cable end sleeves	0.0016 in <sup>2</sup> [1 mm <sup>2</sup> ]/18 AWG
Maximum cross-section to control terminals, flexible wire with cable end sleeves with collar	0.0008 in <sup>2</sup> [0.5 mm <sup>2</sup> ]/20 AWG
Minimum cross-section to control terminals	0.0039 in <sup>2</sup> [0.25 mm <sup>2</sup> ]/24 AWG

\* Power cables, see tables in section "Electrical Data" of the Design Guide

For more information, see section *Electrical Data* in the FC 300 Design Guide, MG.33.BX.YY.

Control card performance:

Scan interval	FC 301: 5 ms / FC 302: 1 ms
Control characteristics:	
Resolution of output frequency at 0-1000 Hz	+/- 0.003 Hz
Repeat accuracy of <i>Precise start/stop</i> (terminals 18, 19)	± 0.1 msec
System response time (terminals 18, 19, 27, 29, 32, 33)	≤ 2 ms
Speed control range (open-loop)	1:100 of synchronous speed
Speed control range (closed-loop)	1:1000 of synchronous speed
Speed accuracy (open-loop)	30–4000 rpm: error ± 8 rpm
Speed accuracy (closed-loop), depending on resolution of feedback device	0–6000 rpm: error ± 0.15 rpm

*All control characteristics are based on a 4-pole asynchronous motor*

Surroundings:

Enclosure	IP 20 <sup>1)</sup> / Type 1, IP 21 <sup>2)</sup> / Type 1, IP 55/ Type 12, IP 66
Vibration test	1.0 g
Max. relative humidity	5%-95% (IEC 721-3-3; Class 3K3 (non-condensing) during operation
Aggressive environment (IEC 60068-2-43)	class H25
Ambient temperature <sup>3)</sup>	Max. 122° F [50° C] (24-hour average maximum 113° F [45° C])

- 1) Only for ≤ 5 hp [3.7 kW] (200-240 V), ≤ 10 hp [7.5 kW] (400-480/ 500 V)
- 2) As enclosure kit for ≤ 5 hp [3.7 kW] (200-240 V), ≤ 10 hp [7.5 kW] (400-480/ 500 V)
- 3) Derating for high ambient temperature, see special conditions in the Design Guide.

Minimum ambient temperature during full-scale operation	32° F [0° C]
Minimum ambient temperature at reduced performance	14° F [-10° C]
Temperature during storage/transport	-13°-+149°/158° F [-25°-+65°/70° C]
Maximum altitude above sea level without derating	3280 ft [1000 m]

*Derating for high altitude, see special conditions in the Design Guide.*

EMC standards, Emission	EN 61800-3, EN 61000-6-3/4, EN 55011 EN 61800-3, EN 61000-6-1/2,
EMC standards, Immunity	EN 61000-4-2, EN 61000-4-3, EN 61000-4-4, EN 61000-4-5, EN 61000-4-6

*See section on special conditions in the Design Guide*

Protection and Features:

- Electronic thermal motor protection against overload.
- Temperature monitoring of the heatsink ensures that the adjustable frequency drive trips if the temperature reaches a predefined level. An overload temperature cannot be reset until the temperature of the heatsink is below the values stated in the tables on the following pages (guideline - these temperatures may vary for different power sizes, frame sizes, enclosure ratings, etc.).
- The adjustable frequency drive is protected against short-circuits on motor terminals U, V, W.
- If a line phase is missing, the adjustable frequency drive trips or issues a warning (depending on the load).
- Monitoring of the intermediate circuit voltage ensures that the adjustable frequency drive trips if the intermediate circuit voltage is too low or too high.
- The adjustable frequency drive constantly checks for critical levels of internal temperature, load current, high voltage on the intermediate circuit and low motor speeds. As a response to a critical level, the adjustable frequency drive can adjust the switching frequency and/or change the switching pattern in order to ensure the performance of the drive.



## 6 Troubleshooting

### 6.1.1 Warnings/Alarm Messages

A warning or an alarm is signaled by the relevant LED on the front of the adjustable frequency drive, indicated by a code on the display.

A warning remains active until its cause is no longer present. Under certain circumstances, operation of the motor may still be continued. Warning messages may be critical, but are not necessarily so.

In the event of an alarm, the adjustable frequency drive will have tripped. Alarms must be reset to restart operation once their cause has been rectified.

**This may be done in three ways:**

1. By using the [RESET] control button on the LCP control panel.
2. Via a digital input with the "Reset" function.
3. Via serial communication/optional serial communication bus.



**NOTE!**

After a manual reset using the [RESET] button on the LCP, the [AUTO ON] button must be pressed to restart the motor.

If an alarm cannot be reset, the reason may be that its cause has not been rectified, or the alarm is trip-locked (see also table on following page).

Alarms that are trip-locked offer additional protection, meaning that the line power supply must be switched off before the alarm can be reset. After being switched back on, the adjustable frequency drive is no longer blocked and may be reset as described above, once the cause has been rectified.

Alarms that are not trip-locked can also be reset using the automatic reset function in par. 14-20 *Reset Mode* (Warning: automatic wake-up is possible!)

If a warning and alarm are marked against a code in the table on the following page, this means that either a warning occurs before an alarm, or that you can specify whether it is a warning or an alarm that is to be displayed for a given fault.

This is possible, for instance, in par.1-90 *Motor Thermal Protection*. After an alarm or trip, the motor carries on coasting, and the alarm and warning flash. Once the problem has been rectified, only the alarm continues flashing until the adjustable frequency drive is reset.

No.	Description	Warning	Alarm/Trip	Alarm/Trip Lock	Parameter Reference
1	10 Volts low	X			
2	Live zero error	(X)	(X)		par. 6-01 <i>Live Zero Timeout Function</i>
3	No motor	(X)			par. 1-80 <i>Function at Stop</i>
4	Line phase loss	(X)	(X)	(X)	par. 14-12 <i>Function at Mains Imbalance</i>
5	DC link voltage high	X			
6	DC link voltage low	X			
7	DC overvoltage	X	X		
8	DC undervoltage	X	X		
9	Inverter overloaded	X	X		
10	Motor ETR overtemperature	(X)	(X)		par.1-90 <i>Motor Thermal Protection</i>
11	Motor thermistor overtemperature	(X)	(X)		par.1-90 <i>Motor Thermal Protection</i>
12	Torque limit	X	X		
13	Overcurrent	X	X	X	
14	Ground Fault	X	X	X	
15	Hardware mismatch		X	X	
16	Short Circuit		X	X	
17	Control word timeout	(X)	(X)		par. 8-04 <i>Control Word Timeout Function</i>
22	Hoist Mech. Brake				
23	Internal Fan Fault	X			
24	External Fan Fault	X			par. 14-53 <i>Fan Monitor</i>
25	Brake resistor short-circuited	X			
26	Brake resistor power limit	(X)	(X)		par.2-13 <i>Brake Power Monitoring</i>
27	Brake chopper short-circuited	X	X		
28	Brake check	(X)	(X)		par.2-15 <i>Brake Check</i>
29	Heatsink temp	X	X	X	
30	Motor phase U missing	(X)	(X)	(X)	par. 4-58 <i>Missing Motor Phase Function</i>
31	Motor phase V missing	(X)	(X)	(X)	par. 4-58 <i>Missing Motor Phase Function</i>
32	Motor phase W missing	(X)	(X)	(X)	par. 4-58 <i>Missing Motor Phase Function</i>
33	Soft-charge fault		X	X	
34	Serial Communication Bus communication fault	X	X		
36	Line failure	X	X		
38	Internal Fault		X	X	
39	Heatsink sensor		X	X	
40	Overload of Digital Output Terminal 27	(X)			par.5-00 <i>Digital I/O Mode</i> , par.5-01 <i>Terminal 27 Mode</i>
41	Overload of Digital Output Terminal 29	(X)			par.5-00 <i>Digital I/O Mode</i> , par. 5-02 <i>Terminal 29 Mode</i>
42	Overload of Digital Output On X30/6	(X)			par. 5-32 <i>Term X30/6 Digi Out (MCB 101)</i>
42	Overload of Digital Output On X30/7	(X)			par. 5-33 <i>Term X30/7 Digi Out (MCB 101)</i>
46	Pwr. card supply		X	X	
47	24 V supply low	X	X	X	
48	1.8 V supply low		X	X	
49	Speed limit	X			
50	AMA calibration failed		X		
51	AMA check $U_{nom}$ and $I_{nom}$		X		
52	AMA low $I_{nom}$		X		
53	AMA motor too big		X		

Table 6.1: Alarm/Warning code list

No.	Description	Warning	Alarm/Trip	Alarm/Trip Lock	Parameter Reference
54	AMA motor too small		X		
55	AMA parameter out of range		X		
56	AMA interrupted by user		X		
57	AMA timeout		X		
58	AMA internal fault	X	X		
59	Current limit	X			
61	Tracking Error	(X)	(X)		par. 4-30 <i>Motor Feedback Loss Function</i>
62	Output Frequency at Maximum Limit	X			
63	Mechanical Brake Low		(X)		par.2-20 <i>Release Brake Current</i>
64	Voltage Limit	X			
65	Control Board Overtemperature	X	X	X	
66	Heatsink Temperature Low	X			
67	Option Configuration has Changed		X		
68	Safe Stop	(X)	(X) <sup>1)</sup>		par. 5-19 <i>Terminal 37 Safe Stop</i>
69	Pwr. Card Temp		X	X	
70	Illegal Adjustable Frequency configuration			X	
71	PTC 1 Safe Stop	X	X <sup>1)</sup>		par. 5-19 <i>Terminal 37 Safe Stop</i>
72	Dangerous Failure			X <sup>1)</sup>	par. 5-19 <i>Terminal 37 Safe Stop</i>
73	Safe Stop Auto Restart				
77	Reduced power mode	X			par. 14-59 <i>Actual Number of Inverter Units</i>
79	Illegal PS config		X	X	
80	Drive Initialized to Default Value		X		
81	CSIV corrupt				
82	CSIV parameter error				
85	Profibus/Profisafe Error				
90	Encoder Loss	(X)	(X)		par. 17-61 <i>Feedback Signal Monitoring S202</i>
91	Analog input 54 wrong settings			X	
100-199	See Instruction Manual for MCO 305				
243	Brake IGBT	X	X		
244	Heatsink temp	X	X	X	
245	Heatsink sensor		X	X	
246	Pwr.card supply		X	X	
247	Pwr.card temp		X	X	
248	Illegal PS config		X	X	
250	New spare part			X	par. 14-23 <i>Typecode Setting</i>
251	New Type Code		X	X	

Table 6.2: Alarm/Warning code list

(X) Dependent on parameter

1) Cannot be auto-reset via par. 14-20 *Reset Mode*

A trip is the action taken when an alarm has occurred. The trip will coast the motor and can be reset by pressing the reset button or make a reset by a digital input (Par. 5-1\* [1]). The origin event that caused an alarm cannot damage the adjustable frequency drive or cause dangerous conditions. A trip lock is an action when an alarm occurs, which may cause damage to adjustable frequency drive or connected parts. A trip lock situation can only be reset by a power cycling.

<i>LED indication</i>	
Warning	yellow
Alarm	flashing red
Trip-locked	yellow and red

Alarm Word Extended Status Word							
Bit	Hex	Dec	Alarm Word	Alarm Word 2	Warning Word	Warning Word 2	Extended Status Word
0	00000001	1	Brake Check	ServiceTrip, Read/Write	Brake Check		Ramping
1	00000002	2	Pwr. Card Temp	ServiceTrip, (reserved)	Pwr. Card Temp		AMA Running
2	00000004	4	Ground Fault	ServiceTrip, Type-code/Sparepart	Ground Fault		Start CW/CCW
3	00000008	8	Ctrl.Card Temp	ServiceTrip, (reserved)	Ctrl.Card Temp		Slow Down
4	00000010	16	Ctrl. Word TO	ServiceTrip, (reserved)	Ctrl. Word TO		Catch Up
5	00000020	32	Overcurrent		Overcurrent		Feedback High
6	00000040	64	Torque Limit		Torque Limit		Feedback Low
7	00000080	128	Motor Th Over		Motor Th Over		Output Current High
8	00000100	256	Motor ETR Over		Motor ETR Over		Output Current Low
9	00000200	512	Inverter Overld.		Inverter Overld.		Output Freq High
10	00000400	1024	DC Undervolt		DC Undervolt		Output Freq Low
11	00000800	2048	DC Overvolt		DC Overvolt		Brake Check OK
12	00001000	4096	Short Circuit		DC Voltage Low		Braking Max
13	00002000	8192	Soft-charge fault		DC Voltage High		Braking
14	00004000	16384	Line ph. Loss		Line ph. Loss		Out of Speed Range
15	00008000	32768	AMA Not OK		No Motor		OVC Active
16	00010000	65536	Live Zero Error		Live Zero Error		AC Brake
17	00020000	131072	Internal Fault	KTY error	10 V Low	KTY Warn	Password Timelock
18	00040000	262144	Brake Overload	Fans error	Brake Overload	Fans Warn	Password Protection
19	00080000	524288	U-phase Loss	ECB error	Brake Resistor	ECB Warn	
20	00100000	1048576	V-phase Loss		Brake IGBT		
21	00200000	2097152	W-phase Loss		Speed Limit		
22	00400000	4194304	Serial Communication Bus Fault		Serial Communication Bus Fault		Unused
23	00800000	8388608	24 V Supply Low		24 V Supply Low		Unused
24	01000000	16777216	Line Failure		Line Failure		Unused
25	02000000	33554432	1.8 V Supply Low		Current Limit		Unused
26	04000000	67108864	Brake Resistor		Low Temp		Unused
27	08000000	134217728	Brake IGBT		Voltage Limit		Unused
28	10000000	268435456	Option Change		Encoder loss		Unused
29	20000000	536870912	Drive Initialized		Output freq. lim.		Unused
30	40000000	1073741824	Safe Stop (A68)	PTC 1 Safe Stop (A71)	Safe Stop (W68)	PTC 1 Safe Stop (W71)	Unused
31	80000000	2147483648	Mech. brake low	Dangerous Failure (A72)	Extended Status Word		Unused

Table 6.3: Description of Alarm Word, Warning Word and Extended Status Word

The alarm words, warning words and extended status words can be read out via serial bus or optional serial communication bus for diagnosis. See also par. 16-94 *Ext. Status Word*.

**WARNING 1, 10 Volts low:**

The 10 V voltage from terminal 50 on the control card is below 10 V. Remove some of the load from terminal 50, as the 10 V supply is overloaded. Max. 15 mA or minimum 590 Ω.

**WARNING/ALARM 2, Live zero error:**

The signal on terminal 53 or 54 is less than 50% of the value set in par. 6-10, 6-12, 6-20, or 6-22, respectively.

**WARNING/ALARM 3, No motor:**

No motor has been connected to the output of the adjustable frequency drive.

**WARNING/ALARM 4, Line phase loss:**

A phase is missing on the supply side, or the line voltage imbalance is too high. This message also appears in case of a fault in the input rectifier on the adjustable frequency drive. Check the supply voltage and supply currents to the adjustable frequency drive.

**WARNING 5, DC link voltage high:**

The intermediate circuit voltage (DC) is higher than the overvoltage limit of the control system. The adjustable frequency drive is still active.

**WARNING 6, DC link voltage low**

The intermediate circuit voltage (DC) is below the undervoltage limit of the control system. The adjustable frequency drive is still active.

**WARNING/ALARM 7, DC overvoltage:**

If the intermediate circuit voltage exceeds the limit, the adjustable frequency drive trips after a time.

**Possible corrections:**

- Connect a brake resistor
- Extend the ramp time
- Activate functions in par. 2-10
- Increase par. 14-26



Alarm/warning limits:			
	3 x 200–240 V	3 x 380–500 V	3 x 525–600 V
	[VDC]	[VDC]	[VDC]
Undervoltage	185	373	532
Voltage warning low	205	410	585
Voltage warning high (w/o brake - w/brake)	390/405	810/840	943/965
Overvoltage	410	855	975

The voltages stated are the intermediate circuit voltage of the adjustable frequency drive with a tolerance of ± 5%. The corresponding AC line voltage is the intermediate circuit voltage (DC link) divided by 1.35.

**WARNING/ALARM 8, DC undervoltage:**

If the intermediate circuit voltage (DC) drops below the "voltage warning low" limit (see table above), the adjustable frequency drive checks if 24 V backup supply is connected.

If no 24 V backup supply is connected, the adjustable frequency drive trips after a given time depending on the unit.

To check whether the supply voltage matches the adjustable frequency drive, see *General Specifications*.

**WARNING/ALARM 9, Inverter overloaded:**

The adjustable frequency drive is about to cut out because of an overload (too high current for too long). The counter for electronic, thermal inverter protection gives a warning at 98% and trips at 100%, while giving an alarm. You cannot reset the adjustable frequency drive until the counter is below 90%.

The fault is that the adjustable frequency drive is overloaded by more than 100% for too long.

**WARNING/ALARM 10, Motor ETR overtemperature:**

According to the electronic thermal protection (ETR), the motor is too hot. You can choose if you want the adjustable frequency drive to give a warning or an alarm when the counter reaches 100% in par. 1-90. The fault is that the motor is overloaded by more than 100% for too long. Check that the motor par. 1-24 is set correctly.

**WARNING/ALARM 11, Motor thermistor overtemp:**

The thermistor or the thermistor connection is disconnected. You can choose if you want the adjustable frequency drive to give a warning or an alarm when the counter reaches 100% in par. 1-90. Make sure that the thermistor is connected correctly between terminal 53 or 54 (analog voltage input) and terminal 50 (+10 V supply), or between terminal 18 or 19 (digital input PNP only) and terminal 50. If aKTY sensor is used, check for correct connection between terminal 54 and 55.

**WARNING/ALARM 12, Torque limit:**

The torque is higher than the value in par. 4-16 (in motor operation) or the torque is higher than the value in par. 4-17 (in regenerative operation).

**WARNING/ALARM 13, Overcurrent:**

The inverter peak current limit (approx. 200% of the rated current) is exceeded. The warning will last approx. 8-12 sec., then the adjustable frequency drive trips and issues an alarm. Turn off the adjustable fre-

quency drive and check if the motor shaft can be turned and if the motor size matches the adjustable frequency drive.

If extended mechanical brake control is selected, trip can be reset externally.

**ALARM 14, Ground fault:**

There is a discharge from the output phases to ground, either in the cable between the adjustable frequency drive and the motor or in the motor itself.

Turn off the adjustable frequency drive and remove the ground fault.

**ALARM 15, Incomplete hardware:**

A fitted option is not handled by the present control board (hardware or software).

**ALARM 16, Short-circuit**

There is short-circuiting in the motor or on the motor terminals.

Turn off the adjustable frequency drive and remove the short-circuit.

**WARNING/ALARM 17, Control word timeout:**

There is no communication to the adjustable frequency drive.

The warning will only be active when par. 8-04 is NOT set to *OFF*.

If par. 8-04 is set to *Stop* and *Trip*, a warning appears and the adjustable frequency drive ramps down until it trips, while giving an alarm.

par. 8-03 *Control word Timeout Time* could possibly be increased.

**WARNING 23, Internal fan fault:**

The fan warning function is an extra protection function that checks if the fan is running / mounted. The fan warning can be disabled in *Fan Monitor*, par. 14-53, (set to [0] Disabled).

**WARNING 24, External fan fault:**

The fan warning function is an extra protection function that checks if the fan is running / mounted. The fan warning can be disabled in *Fan Monitor*, par. 14-53, (set to [0] Disabled).

**WARNING 25, Brake resistor short-circuited:**

The brake resistor is monitored during operation. If it short-circuits, the brake function is disconnected and the warning appears. The adjustable frequency drive still works, but without the brake function. Turn off the adjustable frequency drive and replace the brake resistor (see par. 2-15 *Brake Check*).

**ALARM/WARNING 26, Brake resistor power limit:**

The power transmitted to the brake resistor is calculated as a percentage, as a mean value over the last 120 s, on the basis of the resistance value of the brake resistor (par. 2-11) and the intermediate circuit voltage. The warning is active when the dissipated braking energy is higher than 90%. If *Trip* [2] has been selected in par. 2-13, the adjustable frequency drive cuts out and issues this alarm when the dissipated braking energy is higher than 100%.

**ALARM/ WARNING 27, Brake chopper fault:**

The brake transistor is monitored during operation and if it short-circuits, the brake function disconnects and the warning comes up. The adjustable frequency drive is still able to run, but since the brake transistor has short-circuited, substantial power is transmitted to the brake resistor, even if it is inactive.

Turn off the adjustable frequency drive and remove the brake resistor.

This alarm/warning could also occur if the brake resistor overheats. Terminal 104 to 106 are available as brake resistor. Klixon inputs, see section Brake Resistor Temperature Switch.

Warning: There is a risk of substantial power being transmitted to the brake resistor if the brake transistor is short-circuited.

**ALARM/WARNING 28, Brake check failed:**

Brake resistor fault: the brake resistor is not connected/working.

**ALARM 29, Drive overtemperature:**

If the enclosure is IP 20 or IP 21/Type 1, the cut-out temperature of the heatsink is 203°F ±9°F [95°C ±5°C]. The temperature fault cannot be reset, until the temperature of the heatsink is below 158°F ±9°F [70°C ±5°C].

**The fault could be:**

- Ambient temperature too high
- Motor cable too long

**ALARM 30, Motor phase U missing:**

Motor phase U between the adjustable frequency drive and the motor is missing.

Turn off the adjustable frequency drive and check motor phase U.

**ALARM 31, Motor phase V missing:**

Motor phase V between the adjustable frequency drive and the motor is missing.

Turn off the adjustable frequency drive and check motor phase V.

**ALARM 32, Motor phase W missing:**

Motor phase W between the adjustable frequency drive and the motor is missing.

Turn off the adjustable frequency drive and check motor phase W.

**ALARM 33, Soft-charge fault:**

Too many powerups have occurred within a short period of time. See the chapter *General Specifications* for the allowed number of power-ups within one minute.

**WARNING/ALARM 34, Serial communication bus fault:**

The serial communication bus on the communication option card is not working.

**WARNING/ALARM 36, Line failure:**

This warning/alarm is only active if the supply voltage to the adjustable frequency drive is lost and parameter 14-10 is NOT set to OFF. Possible correction: check the fuses to the adjustable frequency drive

**ALARM 38, Internal fault:**

When this alarm sounds, it may be necessary to contact your Danfoss supplier. Some typical alarm messages:

0 The serial port cannot be initialized. Serious hardware failure

256 The power EEPROM data is defective or too old.

512 The control board EEPROM data is defective or too old.

513 Communication timeout Reading EEPROM data

514 Communication timeout Reading EEPROM data

515 The Application Orientated Control cannot recognize the EEPROM data.

516 Cannot write to the EEPROM because a write command is in progress.

517 The write command has timed out.

518 Failure in the EEPROM

519 Missing or invalid BarCode data in EEPROM 1024 – 1279 CAN message cannot be sent. (1027 indicates a possible hardware failure)

1281 Digital Signal Processor flash timeout

1282 Power micro software version mismatch

1283 Power EEPROM data version mismatch

1284 Cannot read Digital Signal Processor software version

1299 Option SW in slot A is too old.

1300 Option SW in slot B is too old.

1311 Option SW in slot C0 is too old.

1312 Option SW in slot C1 is too old.

1315 Option SW in slot A is not supported (not allowed).

1316 Option SW in slot B is not supported (not allowed).

1317 Option SW in slot C0 is not supported (not allowed).

1318 Option SW in slot C1 is not supported (not allowed).

1536 An exception in the Application Orientated Control is registered. Debug information written in LCP

1792 DSP watchdog is active. Debugging of power part data Motor Orientated Control data not transferred correctly

2049 Power data restarted

2315 Missing SW version from power unit

2816 Stack overflow Control board module

2817 Scheduler slow tasks

2818 Fast tasks

2819 Parameter thread

2820 LCP stack overflow

2821 Serial port overflow

2822 USB port overflow

3072-512 Parameter value is outside its limits. Perform an initialization. Parameter number causing the alarm: Subtract the code from 3072. Ex Error code 3238: 3238-3072 = 166 is outside the limit

5123 Option in slot A: Hardware incompatible with control board hardware

5124 Option in slot B: Hardware incompatible with control board hardware

5125 Option in slot C0: Hardware incompatible with control board hardware

5126 Option in slot C1: Hardware incompatible with control board hardware

5376-623 Out of memory

1

**WARNING 40, Overload of Digital Output Terminal 27**

Check the load connected to terminal 27 or remove short-circuit connection. Check parameters 5-00 and 5-01.

**WARNING 41, Overload of Digital Output Terminal 29:**

Check the load connected to terminal 29 or remove short-circuit connection. Check parameters 5-00 and 5-02.

**WARNING 42, Overload of Digital Output On X30/6:**

Check the load connected to X30/6 or remove short-circuit connection. Check parameter 5-32.

**WARNING 42, Overload of Digital Output On X30/7:**

Check the load connected to X30/7 or remove short-circuit connection. Check parameter 5-33.

**WARNING 47, 24 V supply low:**

The external 24 V DC backup power supply may be overloaded, otherwise contact your Danfoss supplier.

**WARNING 48, 1.8 V supply low:**

Contact your Danfoss supplier.

**WARNING 49, Speed limit:**

The speed is not within the range specified in par. 4-11 and par. 4-13.

**ALARM 50, AMA calibration failed:**

Contact your Danfoss supplier.

**ALARM 51, AMA check Unom and Inom:**

The setting of motor voltage, motor current, and motor power is presumably wrong. Check the settings.

**ALARM 52, AMA low Inom:**

The motor current is too low. Check the settings.

**ALARM 53, AMA motor too big:**

The motor is too big for the AMA to be carried out.

**ALARM 54, AMA motor too small:**

The motor is too big for the AMA to be carried out.

**ALARM 55, AMA par. out of range:**

The par. values found from the motor are outside the acceptable range.

**ALARM 56, AMA interrupted by user:**

The AMA has been interrupted by the user.

**ALARM 57, AMA timeout:**

Try to start the AMA again a number of times, until the AMA is carried out. Please note that repeated runs may heat the motor to a level where the resistances  $R_s$  and  $R_r$  are increased. In most cases, however, this is not critical.

**ALARM 58, AMA internal fault:**

Contact your Danfoss supplier.

**WARNING 59, Current limit:**

The current is higher than the value in par. 4-18.

**WARNING 61, Tracking Error:**

An error between the calculated speed and speed measurement from the feedback device. The function Warning/Alarm/Disabling setting is in par 4-30. Accepted error setting in par 4-31 and the allowed time the error occur setting in par 4-32. During a commissioning procedure the function may be effective.

**WARNING 62, Output Frequency at Maximum Limit:**

The output frequency is higher than the value set in par. 4-19.

**ALARM 63, Mechanical Brake Low:**

The actual motor current has not exceeded the "release brake" current within the "Start delay" time window.

**WARNING 64, Voltage Limit:**

The load and speed combination demands a motor voltage higher than the actual DC link voltage.

**WARNING/ALARM/TRIP 65, Control Card Overtemperature:**

Control card overtemperature: The cut-out temperature of the control card is 176°F [80°C].

**WARNING 66, Heatsink Temperature Low:**

The heatsink temperature is measured as 32°F [0°C]. This could indicate that the temperature sensor is defective and thus the fan speed is increased to the maximum in case the power part or control card is very hot.

**ALARM 67, Option Configuration has Changed:**

One or more options has either been added or removed since the last power-down.

**ALARM 68, Safe Stop:**

Safe Stop has been activated. To resume normal operation, apply 24 V DC to T-37, then send a reset signal (via Bus, Digital I/O, or by pressing [RESET]).

**WARNING 68, Safe Stop:**

Safe Stop has been activated. Normal operation is resumed when safe stop is disabled. Warning: Automatic Restart!

**ALARM 70, Illegal FC Configuration:**

Current combination of control board and power board is illegal.

**ALARM 71, PTC 1 Safe Stop:**

Safe stop has been activated from the MCB 112 PTC thermistor card (motor too warm). Normal operation can be resumed when the MCB 112 applies 24 V DC to T-37 again (when the motor temperature reaches an acceptable level) and when the digital input from the MCB 112 is deactivated. When that happens, a reset signal must be sent (via Bus, Digital I/O, or by pressing [RESET]).

**WARNING 71, PTC 1 Safe Stop:**

Safe stop has been activated from the MCB 112 PTC thermistor card (motor too warm). Normal operation can be resumed when the MCB 112 applies 24 V DC to T-37 again (when the motor temperature reaches an acceptable level) and when the digital input from the MCB 112 is deactivated. Warning: Automatic Restart.

**ALARM 72, Dangerous Failure:**

Safe Stop with Trip Lock. Unexpected signal levels on safe stop and digital input from the MCB 112 PTC thermistor card.

**ALARM 80, Drive Initialized to Default Value:**

Parameter settings are initialized to default setting after a manual (three-finger) reset.

**ALARM 90, Encoder loss:**

Check the connection to encoder option and eventually replace the MCB 102 or MCB 103.

**ALARM 91, Analog Input 54 Wrong Settings:**

Switch S202 has to be set in position OFF (voltage input) when a KTY sensor is connected to analog input terminal 54.

**ALARM 250, New Spare Part:**

The power or switch mode power supply has been exchanged. The adjustable frequency drive type code must be restored in the EEPROM. Select the correct type code in Par 14-23 according to the label on unit. Remember to select 'Save to EEPROM' to complete.

**ALARM 251, New Type Code:**

The adjustable frequency drive has a new type code.

## Index

### 1

101	4-2
102	4-1

### A

Abbreviations	1-3
Access To Control Terminals	3-18
[Activate Brake Speed Hz] 2-22	4-15
[Activate Brake Speed Rpm] 2-21	4-15
Alarm Messages	6-1
Ama	3-25
Analog Inputs	5-2
Analog Output	5-3
Approvals	1-2
Automatic Motor Adaptation (ama)	3-25, 4-6

### B

Brake Check 2-15	4-13
Brake Control	6-5
Brake Function 2-10	4-12
Brake Power Limit (kw) 2-12	4-12
Brake Power Monitoring 2-13	4-13
Brake Resistor (ohm) 2-11	4-12

### C

Cable Lengths And Cross-sections	5-4
Cable Lengths And Cross-sections-continued	5-5
Catch Up	4-22
Checklist	3-1
Communication Option	6-6
Connection To Line Power	3-8
Control Cables	3-23
Control Cables	3-22
Control Card Performance	5-5
Control Card, +10 V Dc Output	5-3
Control Card, 24 V Dc Output	5-3
Control Card, Rs-485 Serial Communication	5-3
Control Card, Usb Serial Communication	5-4
Control Characteristics	5-5
Control Terminals	3-19
Cooling	4-9
Cooling Conditions	3-5

### D

Dc Backup	1-1
Dc Link	6-4
Decoupling Plate	3-11
Default Settings	4-29
Devicenet	1-1
Digital I/o Mode 5-00	4-18
Digital Inputs:	5-1
Digital Output	5-3
Disposal Instructions	1-3

### E

Electrical Installation	3-19, 3-22
-------------------------	------------

Electrical Terminals	3-22
Electronic Terminal Relay	4-11
Etr	6-5
<b>F</b>	
Function Relay 5-40	4-25
Fuses	3-14
<b>G</b>	
Gain Boost Factor 2-28	4-16
General Warning	2-2
Graphical Display	4-1
<b>I</b>	
Intermediate Circuit	6-4
Ip21 / Type 1	1-1
<b>J</b>	
[Jog Speed Hz] 3-11	4-17
<b>K</b>	
Kty Sensor	6-5
<b>L</b>	
Language 0-01	4-4
Language Package 1	4-4
Language Package 2	4-4
Language Package 3	4-4
Language Package 4	4-4
Lcp Copy 0-50	4-8
Leakage Current	2-2
Leds	4-1, 4-2
Line Power Supply (L1, L2, L3)	5-1
Local Control Panel	4-2
<b>M</b>	
Main Reactance	4-6
Maximum Reference 3-03	4-7
Mct 10	1-1
Mechanical Brake Control	3-27
Mechanical Dimensions	3-2
Mechanical Mounting	3-5
Minimum Reference 3-02	4-7
Motor Connection	3-11
Motor Current 1-24	4-5
Motor Frequency 1-23	4-5
Motor Nameplate	3-25
Motor Nominal Speed 1-25	4-5
Motor Output	5-1
Motor Power 1-20	4-5
Motor Protection	4-9, 5-5
Motor Speed Unit 0-02	4-8
Motor Thermal Protection	3-28, 4-9
Motor Voltage 1-22	4-5
<b>N</b>	
Nameplate Data	3-25

Non-ul Compliance .....	3-14
Numerical Display .....	4-2

## O

Operation Mode 14-22 .....	4-27
Output Performance (u, V, W) .....	5-1
Overload Mode 1-04 .....	4-9

## P

Panel Through Mounting .....	3-6
Parallel Connection Of Motors .....	3-27
Potentiometer Reference .....	3-21
Preset Reference 3-10 .....	4-17
Profibus .....	1-1
Protection .....	3-14
Protection And Features .....	5-5
Pulse Start/stop .....	3-20
Pulse/encoder Inputs .....	5-3

## R

Ramp 1 Ramp-down Time 3-42 .....	4-8
Ramp 1 Ramp-up Time 3-41 .....	4-7
Reference Resource 2 3-16 .....	4-18
Reference Resource 3 3-17 .....	4-18
Reference Source 1 3-15 .....	4-17
Relay Outputs .....	4-23
Relay Outputs .....	5-4
Release Brake Current 2-20 .....	4-15
Removal Of Knockouts For Extra Cables .....	3-8
Repair Work .....	2-2
Residual Current Device .....	2-2
Rfi 1 14-50 .....	4-28

## S

Safe Stop .....	2-3
Safety Precautions .....	2-1
Serial Communication .....	5-3
Shaft Performance Levels .....	1-1
Shielded/armored .....	3-23
Side-by-side Installation .....	3-5
Sine-wave Filter .....	3-14
Software Version 15-43 .....	4-28
Speed Up/down .....	3-21
Start/stop .....	3-20
Stator Leakage Reactance .....	4-6
Status Messages .....	4-1
Stop Delay 2-24 .....	4-15
Surroundings .....	5-5
Switches S201, S202, And S801 .....	3-24
Symbols .....	1-2

## T

Terminal 27 Mode 5-01 .....	4-19
Thermistor .....	4-9
Thermistor Source 1-93 .....	4-12
Torque Characteristics .....	5-1
Torque Characteristics 1-03 .....	4-8
Torque Ref 2-26 .....	4-16

**U**

Unintended Start ..... 2-2

**V**

Voltage Level ..... 5-1

Voltage Reference Via A Potentiometer ..... 3-21

**W**

Warnings ..... 6-1