

## Contents

<b>1 How to Read these Operating Instructions</b>	<b>3</b>
Approvals	4
Symbols	4
Abbreviations	5
<b>2 Safety Instructions and General Warning</b>	<b>7</b>
High Voltage	7
Safe Stop of FC 300	9
IT Mains	13
<b>3 How to Install</b>	<b>15</b>
Mechanical Installation	18
Electrical Installation	20
Connection to Mains and Earthing	21
Motor Connection	24
Fuses	27
Electrical Installation, Control Terminals	31
Connection Examples	32
Electrical Installation, Control Cables	34
Switches S201, S202, and S801	36
Additional Connections	39
Mechanical Brake Control	39
Motor Thermal Protection	39
How to Connect a PC to the Frequency Converter	40
The FC 300 PC Software	40
<b>4 How to Programme</b>	<b>41</b>
The Graphical and Numerical LCP	41
How to Programme on the Graphical LCP	41
How to Programme on the Numerical Local Control Panel	41
Quick Setup	43
Basic setup parameters	47
Parameter Lists	66
<b>5 General Specifications</b>	<b>97</b>
<b>6 Troubleshooting</b>	<b>103</b>
Warnings/Alarm Messages	103
<b>Index</b>	<b>110</b>



1

# 1 How to Read these Operating Instructions

1

**VLT AutomationDrive**  
**Operating Instructions**  
**Software version: 5.8x**

These Operating Instructions can be used for all VLT AutomationDrive frequency converters with software version 5.8x. The software version number can be seen from par. 15-43 *Software Version*.

## 1.1.1 How to Read these Operating Instructions

VLT AutomationDrive is designed to provide high shaft performance on electrical motors. Please read this manual carefully for proper use. Incorrect handling of the frequency converter may cause improper operation of the frequency converter or related equipment, shorten lifetime or cause other troubles.

These Operating Instructions will help you get started, install, program, and troubleshoot your VLT AutomationDrive.

The VLT AutomationDrive comes in twoshaft performance levels. FC 301 ranges from scalar (U/f) to VVC+ and handles asynchronous motors only. FC 302 is a high performance frequency converter for asynchronous as well as permanent motors and handles various kinds of motor control principles such as scalar (U/f), VVC+ and Flux vector motor control.

These Operating Instructions cover both FC 301 and FC 302. Where information covers both series, we refer to FC 300. Otherwise, we refer specifically to either FC 301 or FC 302.

Chapter 1, **How to Read these Operating Instructions**, introduces the manual and informs you about the approvals, symbols, and abbreviations used in this literature.

Chapter 2, **Safety Instructions and General Warnings**, entails instructions on how to handle the FC 300 correctly.

Chapter 3, **How to Install**, guides you through mechanical and technical installation.

Chapter 4, **How to Programme**, shows you how to operate and programme the FC 300 via the LCP.

Chapter 5, **General Specifications**, contains technical data about FC 300.

Chapter 6, **Troubleshooting**, assists you in solving problems that may occur when using FC 300.

### Available Literature for FC 300

- The VLT AutomationDrive Operating Instructions provide the necessary information for getting the drive up and running.
- The VLT AutomationDrive Design Guide entails all technical information about the drive design and applications including encoder, resolver and relay options.
- The VLT AutomationDrive Profibus Operating Instructions provide the information required for controlling, monitoring and programming the drive via a Profibus fieldbus.
- The VLT AutomationDrive DeviceNet Operating Instructions provide the information required for controlling, monitoring and programming the drive via a DeviceNet fieldbus.
- The VLT AutomationDrive MCT 10 Operating Instructions provide information for installation and use of the software on a PC.
- The VLT AutomationDrive IP21 / Type 1 Instruction provides information for installing the IP21 / Type 1 option.
- The VLT AutomationDrive 24 V DC Backup Instruction provides information for installing the 24 V DC Backup option.

Danfoss technical literature is also available online at [www.danfoss.com/drives](http://www.danfoss.com/drives).

1

### 1.1.2 Approvals



### 1.1.3 Symbols

Symbols used in this Operating Instructions.

	<b>NB!</b> Indicates something to be noted by the reader.
---	--

	Indicates a general warning.
---	------------------------------

	Indicates a high-voltage warning.
---	-----------------------------------

*	Indicates default setting
---	---------------------------

### 1.1.4 Abbreviations

Alternating current	AC
American wire gauge	AWG
Ampere/AMP	A
Automatic Motor Adaptation	AMA
Current limit	I <sub>LIM</sub>
Degrees Celsius	°C
Direct current	DC
Drive Dependent	D-TYPE
Electro Magnetic Compatibility	EMC
Electronic Thermal Relay	ETR
Frequency Converter	FC
Gram	g
Hertz	Hz
Kilohertz	kHz
Local Control Panel	LCP
Meter	m
Millihenry Inductance	mH
Milliampere	mA
Millisecond	ms
Minute	min
Motion Control Tool	MCT
Nanofarad	nF
Newton Meters	Nm
Nominal motor current	I <sub>M,N</sub>
Nominal motor frequency	f <sub>M,N</sub>
Nominal motor power	P <sub>M,N</sub>
Nominal motor voltage	U <sub>M,N</sub>
Parameter	par.
Protective Extra Low Voltage	PELV
Printed Circuit Board	PCB
Rated Inverter Output Current	I <sub>INV</sub>
Revolutions Per Minute	RPM
Regenerative terminals	Regen
Second	s
Synchronous Motor Speed	n <sub>s</sub>
Torque limit	T <sub>LIM</sub>
Volts	V
The maximum output current	I <sub>VLT,MAX</sub>
The rated output current supplied by the frequency converter	I <sub>VLT,N</sub>

### 1.1.5 Disposal Instruction



Equipment containing electrical components may not be disposed of together with domestic waste.  
It must be separately collected with electrical and electronic waste according to local and currently valid legislation.



2

## 2 Safety Instructions and General Warning

2

 The DC link capacitors remain charged after power has been disconnected. To avoid electrical shock hazard, disconnect the frequency converter from mains before carrying out maintenance. When using a PM-motor, make sure it is disconnected. Before doing service on the frequency converter wait at least the amount of time indicated below:

Voltage	Power	Waiting Time
200 - 240 V	0.25 - 3.7 kW	4 minutes
	5.5 - 37 kW	15 minutes
380 - 500 V	0.37 - 7.5 kW	4 minutes
	11 - 75 kW	15 minutes
525 - 600 V	0.75 - 7.5 kW	4 minutes
	11 - 75 kW	15 minutes
525 - 690 V	11 - 75 kW	15 minutes

### 2.1.1 High Voltage

 The voltage of the frequency converter is dangerous whenever the frequency converter is connected to mains. Incorrect installation or operation of the motor or frequency converter may cause damage to the equipment, serious personal injury or death. The instructions in this manual must consequently be observed, as well as applicable local and national rules and safety regulations.

 **Installation in high altitudes**  
 380 - 500 V: At altitudes above 3 km, please contact Danfoss regarding PELV.  
 525 - 690 V: At altitudes above 2 km, please contact Danfoss regarding PELV.

### 2.1.2 Safety Precautions

 The voltage of the frequency converter is dangerous whenever connected to mains. Incorrect installation of the motor, frequency converter or fieldbus may cause damage to the equipment, serious personal injury or death. Consequently, the instructions in this manual, as well as national and local rules and safety regulations, must be complied with.

#### Safety Regulations

1. The mains supply to the frequency converter must be disconnected whenever repair work is to be carried out. Check that the mains supply has been disconnected and that the necessary time has elapsed before removing motor and mains supply plugs.
2. The [OFF] button on the control panel of the frequency converter does not disconnect the mains supply and consequently it must not be used as a safety switch.
3. The equipment must be properly earthed, the user must be protected against supply voltage and the motor must be protected against overload in accordance with applicable national and local regulations.
4. The earth leakage current exceeds 3.5 mA.
5. Protection against motor overload is not included in the factory setting. If this function is desired, set par.1-90 *Motor Thermal Protection* to data value ETR trip 1 [4] or data value ETR warning 1 [3].
6. Do not remove the plugs for the motor and mains supply while the frequency converter is connected to mains. Check that the mains supply has been disconnected and that the necessary time has elapsed before removing motor and mains plugs.

- Please note that the frequency converter has more voltage sources than L1, L2 and L3, when load sharing (linking of DC intermediate circuit) or external 24 V DC are installed. Check that all voltage sources have been disconnected and that the necessary time has elapsed before commencing repair work.

#### Warning against unintended start

- The motor can be brought to a stop by means of digital commands, bus commands, references or a local stop, while the frequency converter is connected to mains. If personal safety considerations (e.g. risk of personal injury caused by contact with moving machine parts following an unintentional start) make it necessary to ensure that no unintended start occurs, these stop functions are not sufficient. In such cases the mains supply must be disconnected or the *Safe Stop* function must be activated.
- The motor may start while setting the parameters. If this means that personal safety may be compromised (e.g. personal injury caused by contact with moving machine parts), motor starting must be prevented, for instance by use of the *Safe Stop* function or secure disconnection of the motor connection.
- A motor that has been stopped with the mains supply connected, may start if faults occur in the electronics of the frequency converter, through temporary overload or if a fault in the power supply grid or motor connection is remedied. If unintended start must be prevented for personal safety reasons (e.g. risk of injury caused by contact with moving machine parts), the normal stop functions of the frequency converter are not sufficient. In such cases the mains supply must be disconnected or the *Safe Stop* function must be activated.



#### NB!

When using the *Safe Stop* function, always follow the instructions in the *Safe Stop* section of the VLT AutomationDrive Design Guide.

- Control signals from, or internally within, the frequency converter may in rare cases be activated in error, be delayed or fail to occur entirely. When used in situations where safety is critical, e.g. when controlling the electromagnetic brake function of a hoist application, these control signals must not be relied on exclusively.



Touching the electrical parts may be fatal - even after the equipment has been disconnected from mains.

Also make sure that other voltage inputs have been disconnected, such as external 24 V DC, load sharing (linkage of DC intermediate circuit), as well as the motor connection for kinetic back up.

Systems where frequency converters are installed must, if necessary, be equipped with additional monitoring and protective devices according to the valid safety regulations, e.g. law on mechanical tools, regulations for the prevention of accidents etc. Modifications on the frequency converters by means of the operating software are allowed.

Hoisting applications:

The frequency converter functions for controlling mechanical brakes cannot be considered as a primary safety circuit. There must always be a redundancy for controlling external brakes.

#### Protection Mode

Once a hardware limit on motor current or dc-link voltage is exceeded the drive will enter "Protection mode". "Protection mode" means a change of the PWM modulation strategy and a low switching frequency to minimize losses. This continues 10 sec after the last fault and increases the reliability and the robustness of the drive while re-establishing full control of the motor.

In hoist applications "Protection mode" is not usable because the drive will usually not be able to leave this mode again and therefore it will extend the time before activating the brake – which is not recommendable.

The "Protection mode" can be disabled by setting par. 14-26 *Trip Delay at Inverter Fault* to zero which means that the drive will trip immediately if one of the hardware limits is exceeded.



#### NB!

It is recommended to disable protection mode in hoisting applications (par. 14-26 *Trip Delay at Inverter Fault* = 0)



### 2.1.3 General Warning



**Warning:**  
 Touching the electrical parts may be fatal - even after the equipment has been disconnected from mains.  
 Also make sure that other voltage inputs have been disconnected, such as load-sharing (linkage of DC intermediate circuit), as well as the motor connection for kinetic back-up.  
 Using VLT AutomationDrive: wait at least 15 minutes.  
 Shorter time is allowed only if indicated on the nameplate for the specific unit.



**Leakage Current**  
 The earth leakage current from the frequency converter exceeds 3.5 mA. To ensure that the earth cable has a good mechanical connection to the earth connection (terminal 95), the cable cross section must be at least 10 mm<sup>2</sup> or 2 times rated earth wires terminated separately.

**Residual Current Device**  
 This product can cause a D.C. current in the protective conductor. Where a residual current device (RCD) is used for extra protection, only an RCD of Type B (time delayed) shall be used on the supply side of this product. See also RCD Application Note MN.90.GX.02. Protective earthing of the VLT AutomationDrive and the use of RCD's must always follow national and local regulations.



**NB!**  
 For vertical lifting or hoisting applications it is strongly recommended to ensure that the load can be stopped in case of an emergency or a malfunction of a single part such as a contactor, etc.  
 If the frequency converter is in alarm mode or in an over voltage situation, the mechanical brake cuts in.

### 2.1.4 Before Commencing Repair Work

1. Disconnect the frequency converter from mains
2. Disconnect DC bus terminals 88 and 89 from load share applications
3. Wait for discharge of the DC-link. See period of time on the warning label
4. Remove motor cable

### 2.1.5 Safe Stop of FC 300

The FC 302, and also the FC 301 in A1 enclosure, can perform the safety function *Safe Torque Off* (As defined by IEC 61800-5-2) or *Stop Category 0* (as defined in EN 60204-1).

FC 301 A1 enclosure: When Safe Stop is included in the drive, position 18 of Type Code must be either T or U. If position 18 is B or X, Safe Stop Terminal 37 is not included!

Example:

Type Code for FC 301 A1 with Safe Stop: FC-301PK75T4Z20H4TGCXXXSXXXXA0BXCXXXD0

It is designed and approved suitable for the requirements of :

- Safety Cat. 3 (EN 954-1) / PL "d" (ISO 13849-1)
- Performance Level "d" in ISO EN 13849-1
- SIL 2 Capability in IEC 61508 and EN 61800-5-2
- SILCL 2 in EN 61062

This functionality is called Safe Stop. Prior to integration and use of Safe Stop in an installation, a thorough risk analysis on the installation must be carried out in order to determine whether the Safe Stop functionality and safety levels are appropriate and sufficient.



After installation of Safe Stop, a commissioning test as specified in section *Safe Stop Commissioning Test* of the Design Guide must be performed. A passed commissioning test is mandatory for fulfilment of Safety Cat. 3 (EN 954-1) / PL "d" (ISO 13849-1)

## 2

The following values are associated to the different types of safety levels:

Performance Level "d":

- MTTFD (Mean Time To Dangerous Failure): 24816 years
- DC (Diagnostic Coverage): 99,99%
- Category 3

SIL 2 Capability, SILCL 2:

- PFH (Probability of Dangerous failure per Hour) =  $7e-10$  FIT =  $7e-19$ /h
- SFF (Safe Failure Fraction) > 99%
- HFT (Hardware Fault Tolerance) = 0 (1oo1D architecture)

In order to install and use the Safe Stop function in accordance with the requirements of Safety Cat. 3 (EN 954-1) / PL "d" (ISO 13849-1), the related information and instructions of the VLT AutomationDrive Design Guide MG.33.BX.YY must be followed! The information and instructions of the Operating Instructions are not sufficient for a correct and safe use of the Safe Stop functionality!

### Abbreviations related to Functional Safety

Abbreviation	Reference	Description
Cat.	EN 954-1	Safety category, levels 1-4
FIT		Failure In Time: $1E-9$ hours
HFT	IEC 61508	Hardware Fault Tolerance: HFT = n means, that n+1 faults could cause a loss of the safety function
MTTFd	EN ISO 13849-1	Mean Time To dangerous Failure: (The total number of life units) / (the number of dangerous, undetected failures), during particular measurement interval under stated conditions
PFHd	IEC 61508	Probability of Dangerous Failures per Hour. This value shall be considered if the safety device is operated in high demand (more often than once per year) or continuous mode of operation, where the frequency of demands for operation made on a safety-related system is greater than one per year or greater than twice the proof-test frequency.
PL	EN ISO 13849-1	Performance Level: Corresponds SIL, Levels a-e
SFF	IEC 61508	Safe Failure Fraction [%] ; Percentage part of safe failures and dangerous detected failures of a safety function or a subsystem related to all failures.
SIL	IEC 61508	Safety Integrity Level
STO	EN 61800-5-2	Safe Torque Off

Prüf- und Zertifizierungsstelle  
im BG-PRÜFZERT



**BGIA**  
Berufsgenossenschaftliches  
Institut für Arbeitsschutz

Hauptverband der gewerblichen  
Berufsgenossenschaften

**Translation**

In any case, the German original shall prevail.

**Type Test Certificate**

05 06004

No. of certificate

Name and address of the holder of the certificate: (customer) Danfoss Drives A/S, Ulnaes 1 DK-6300 Graasten, Dänemark

Name and address of the manufacturer: Danfoss Drives A/S, Ulnaes 1 DK-6300 Graasten, Dänemark

Ref. of customer:

Ref. of Test and Certification Body: Apf/Köh VE-Nr. 2003 23220

Date of Issue: 13.04.2005

Product designation: Frequency converter with integrated safety functions

Type: VLT® Automation Drive FC 302

Intended purpose: Implementation of safety function „Safe Stop“

Testing based on: EN 954-1, 1997-03, DKE AK 226.03, 1998-06, EN ISO 13849-2; 2003-12, EN 61800-3, 2001-02, EN 61800-5-1, 2003-09,

Test certificate: No.: 2003 23220 from 13.04.2005

Remarks: The presented types of the frequency converter FC 302 meet the requirements laid down in the test bases. With correct wiring a category 3 according to DIN EN 954-1 is reached for the safety function.

The type tested complies with the provisions laid down in the directive 98/37/EC (Machinery).

Further conditions are laid down in the Rules of Procedure for Testing and Certification of April 2004.

130BA373.11

Head of certification body

(Prof. Dr. rer. nat. Dietmar Reinert)

Certification officer

(Dipl.-Ing. R. Apfeld)

PZB10E  
01.05



Postal address:  
53754 Sankt Augustin

Office:  
Alte Heerstraße 111  
53757 Sankt Augustin

Phone: 0 22 41/2 31-02  
Fax: 0 22 41/2 31-22 34



# Certificate

TÜV NORD SysTec GmbH & Co. KG hereby certifies

**Danfoss Drives A/S**  
 Ulsnæs 1  
 DK-6300 Graasten  
 Denmark

for the realisation of the function "Safe Stop - STO"  
 in the Danfoss drives types

**VLT® Automation Drive FC 302, VLT® Automation Drive FC 301 in the A1 housing  
 VLT® AQUA Drive FC 202, VLT® HVAC Drive FC 102**

the compliance with the requirements listed in the following standards

- IEC 61800-5-2:2007; Designated Safety Function "Safe Torque Off - STO; SIL2 capability
- IEC 61508; Part 1:1998 + Corrigendum 1999
- EN 61508; Part 2:2000; SIL 2 capability for STO function
- EN ISO 13849-1:2006; PL d, EN 954-1:1996; Category 3
- IEC 62061:2005; SILCL 2

based on report No. SAS-163/2006C in the valid version.

This certificate entitles the holder to use the mark:



*[Signature]*  
 Dr. Immanuel Höfer  
 08

Expiry date: 2013-01-16  
 Certification No.: SAS1724/07, Vers. 1.0  
 Reference No.: M.IB5.03.122.01.SLA  
 86150 Augsburg  
 Augsburg, 2008-01-16

TÜV NORD SysTec GmbH & Co. KG  
 Branch South  
 Halderstraße 27  
 86150 Augsburg  
 Germany

130BB178.10

### 2.1.6 Safe Stop Installation - FC 302 only (and FC 301 in Frame Size A1)

To carry out an installation of a Category 0 Stop (EN60204) in conformance with Safety Cat. 3 (EN 954-1) / PL "d" (ISO 13849-1), follow these instructions:

1. The bridge (jumper) between Terminal 37 and 24 V DC must be removed. Cutting or breaking the jumper is not sufficient. Remove it entirely to avoid short-circuiting. See jumper on illustration.
2. Connect terminal 37 to 24 V DC by a short-circuit protected cable. The 24 V DC voltage supply must be interruptible by a Cat. 3 (EN 954-1) / PL "d" (ISO 13849-1) circuit interrupt device. If the interrupt device and the frequency converter are placed in the same installation panel, you can use a regular cable instead of a protected one.
3. The Safe Stop function only fulfills Cat. 3 (EN 954-1) / PL "d" (ISO 13849-1) if particular protection against, or avoidance of, conductive contamination is provided. Such a protection is achieved by using FC 302 with protection class IP54 or higher. If FC 302 with lower protection (or FC 301 A1, which is only delivered with an IP21 enclosure) are used, then an operating environment corresponding to the inside of an IP54 encapsulation must be ensured. An obvious solution, if there is a risk of conductive contamination in the operating environment, would be to mount the devices in a cabinet that provides IP54 protection.

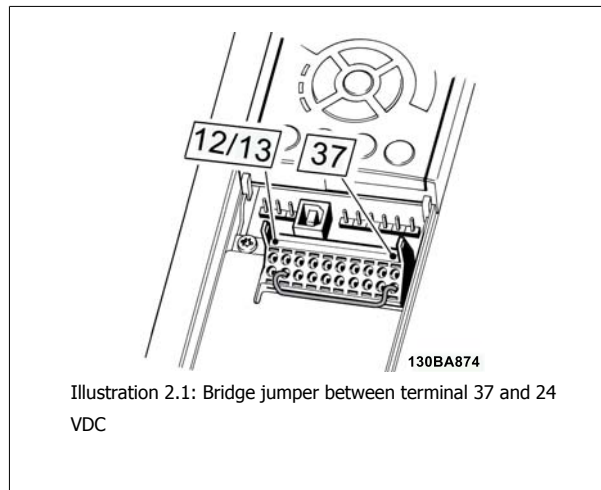

Illustration 2.1: Bridge jumper between terminal 37 and 24 VDC

The illustration below shows a Stopping Category 0 (EN 60204-1) with Safety Cat. 3 (EN 954-1) / PL "d" (ISO 13849-1). The circuit interrupt is caused by an opening door contact. The illustration also shows how to connect a non-safety related hardware coast.

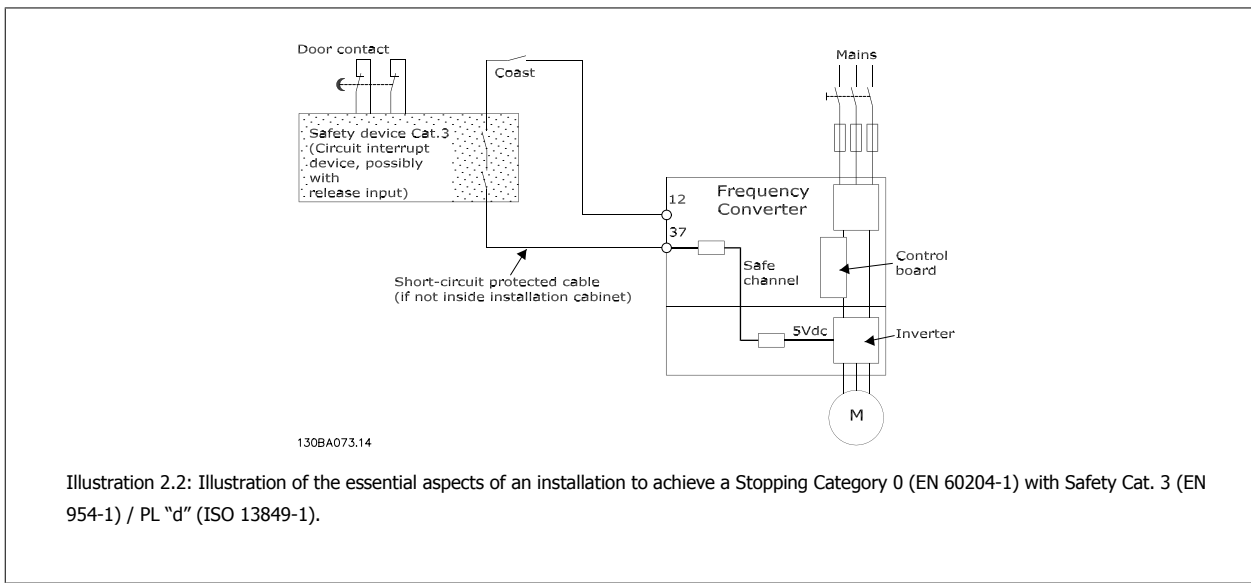

Illustration 2.2: Illustration of the essential aspects of an installation to achieve a Stopping Category 0 (EN 60204-1) with Safety Cat. 3 (EN 954-1) / PL "d" (ISO 13849-1).

### 2.1.7 IT Mains

Par. 14-50 *RFI Filter* can be used to disconnect the internal RFI capacitors from the RFI filter to ground in the 380 - 500 V frequency converters. If this is done it will reduce the RFI performance to A2 level. For the 525 - 690 V frequency converters, par. 14-50 *RFI Filter* has no function. The RFI switch cannot be opened.

**3**

## 3 How to Install

### 3.1.1 About How to Install

This chapter covers mechanical and electrical installations to and from power terminals and control card terminals. Electrical installation of *options* is described in the relevant Operating Instructions and Design Guide.

Read the safety instructions before installing the unit.

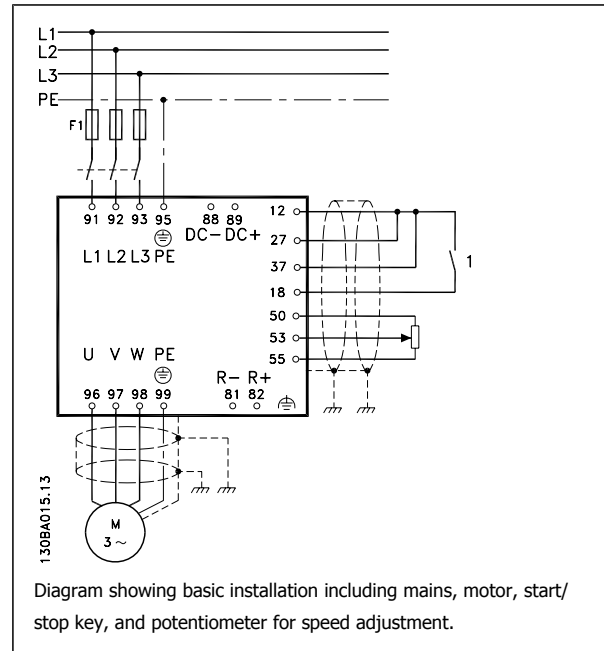

3

### 3.1.2 Checklist

When unpacking the frequency converter, ensure that the unit is undamaged and complete. Use the following table to identify the packaging:

Frame size:	A1	A2	A3	A5	B1/B3	B2/B4	C1/C3	C2/C4
IP:	20	20/21	20/21	55/66	20/21/5/66	20/21/55/66	20/21/55/66	20/21/55/66

130BA295.10

130BA288.10

For power ratings, please see *Mechanical Dimensions* table on the next page

Table 3.1: Unpacking table

Please note that a selection of screwdrivers (Phillips or cross-thread screwdriver and Torx), a side-cutter, drill and knife is also recommended to have handy for unpacking and mounting the frequency converter. The packaging for these enclosures contains, as shown: Accessories bag(s), documentation and the unit. Depending on options fitted there may be one or two bags and one or more booklets.

3

A1		IP20	IP20/21		IP20/21	A3		IP20/21	A5		IP55/66	B1		IP21/55/66	B2		IP21/55/66	B3		IP20	B4		IP20	C1		IP21/55/66	C2		IP21/55/66	C3		IP20	C4		IP20				
<p>Accessory bags containing necessary brackets, screws and connectors are included with the drives upon delivery.</p>										<p>Top and bottom mounting holes (B4, C3 and C4 only)</p>																													
<p>All measurements in mm. * A5 in IP55/66 only</p>																																							



Frame Size	A1	A2	A3	A5	B1	B2	B3	B4	C1	C2	C3	C4
<b>Rated Power [kW]</b>	200-240 V 0.25-1.5 380-480/500 V 0.37-1.5 525-600 V 0.75-7.5 525-690 V	0.25-2.2 0.37-4.0	3-3.7 5.5-7.5 0.75-7.5	0.25-3.7 0.37-7.5 0.75-7.5	5.5-7.5 11-15 11-15	11 18.5-22 11-22	5.5-7.5 11-15 11-15	11-15 18.5-30 18.5-30	15-22 30-45 30-45	30-37 55-75 55-90 30-75	18.5-22 37-45 37-45	30-37 55-75 55-90
<b>IP NEMA</b>	20 Chassis	20 Chassis	20 Chassis	55/66 Type 12	21/ 55/66 Type 1/Type 12	21/55/66 Type 1/Type 12	20 Chassis	20 Chassis	21/55/66 Type 1/Type 12	21/55/66 Type 1/Type 12	20 Chassis	20 Chassis
<b>Height</b>												
Height of back plate	A 200 mm A 316 mm	268 mm 374 mm	268 mm 374 mm	420 mm	480 mm	650 mm	399 mm 420 mm	520 mm 595 mm	680 mm	770 mm	550 mm 630 mm	660 mm 800 mm
Height with de-coupling plate												
Distance between mounting holes	a 190 mm	257 mm	257 mm	402 mm	454 mm	624 mm	380 mm	495 mm	648 mm	739 mm	521 mm	631 mm
<b>Width</b>												
Width of back plate	B 75 mm	90 mm	130 mm	242 mm	242 mm	242 mm	165 mm	230 mm	308 mm	370 mm	308 mm	370 mm
Width of back plate with one C option	B 130 mm	130 mm	170 mm	242 mm	242 mm	242 mm	205 mm	230 mm	308 mm	370 mm	308 mm	370 mm
Width of back plate with two C options	B 150 mm	150 mm	190 mm	242 mm	242 mm	242 mm	225 mm	230 mm	308 mm	370 mm	308 mm	370 mm
Distance between mounting holes	b 60 mm	70 mm	110 mm	215 mm	210 mm	210 mm	140 mm	200 mm	272 mm	334 mm	270 mm	330 mm
<b>Depth</b>												
Depth without option A/B	C 207 mm	207 mm	205 mm	195 mm	260 mm	260 mm	249 mm	242 mm	310 mm	335 mm	333 mm	333 mm
With option A/B	C 222 mm	222 mm	220 mm	195 mm	260 mm	260 mm	262 mm	242 mm	310 mm	335 mm	333 mm	333 mm
<b>Screw holes</b>												
c	6.0 mm	8.0 mm	8.0 mm	8.25 mm	12 mm	12 mm	8 mm		12.5 mm	12.5 mm		
d	ø8 mm	ø11 mm	ø11 mm	ø12 mm	ø19 mm	ø19 mm	12 mm		ø19 mm	ø19 mm		
e	ø5 mm	ø5.5 mm	ø5.5 mm	ø6.5 mm	ø9 mm	ø9 mm	6.8 mm	8.5 mm	ø9 mm	ø9 mm	8.5 mm	8.5 mm
f	5 mm	9 mm	9 mm	9 mm	9 mm	9 mm	7.9 mm	15 mm	9.8 mm	9.8 mm	17 mm	17 mm
<b>Max weight</b>	2.7 kg	4.9 kg	5.3 kg	13.5/14.2 kg	23 kg	27 kg	12 kg	23.5 kg	45 kg	65 kg	35 kg	50 kg

## 3.2 Mechanical Installation

### 3.2.1 Mechanical Mounting

All Frame Sizes allow side-by-side installation except when a *IP21/IP4X/ TYPE 1 Enclosure Kit* is used (see the *Options and Accessories* section of the Design Guide).

3

If the IP 21 Enclosure kit is used on frame size A1, A2 or A3, there must be a clearance between the drives of min. 50 mm.

For optimal cooling conditions allow a free air passage above and below the frequency converter. See table below.

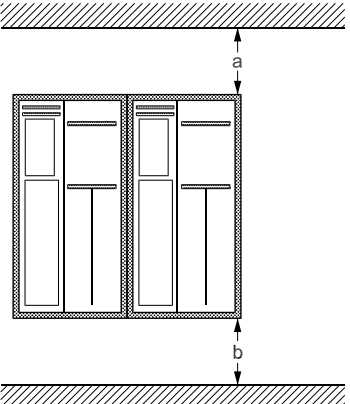

**Air passage for different frame sizes**

Frame size:	A1*	A2	A3	A5	B1	B2	B3	B4	C1	C2	C3	C4
a (mm):	100	100	100	100	100	200	100	200	200	225	200	225
b (mm):	100	100	100	100	100	200	100	200	200	225	200	225

Table 3.2: \* FC 301 only

1. Drill holes in accordance with the measurements given.
2. You must provide screws suitable for the surface on which you want to mount the frequency converter. Retighten all four screws.

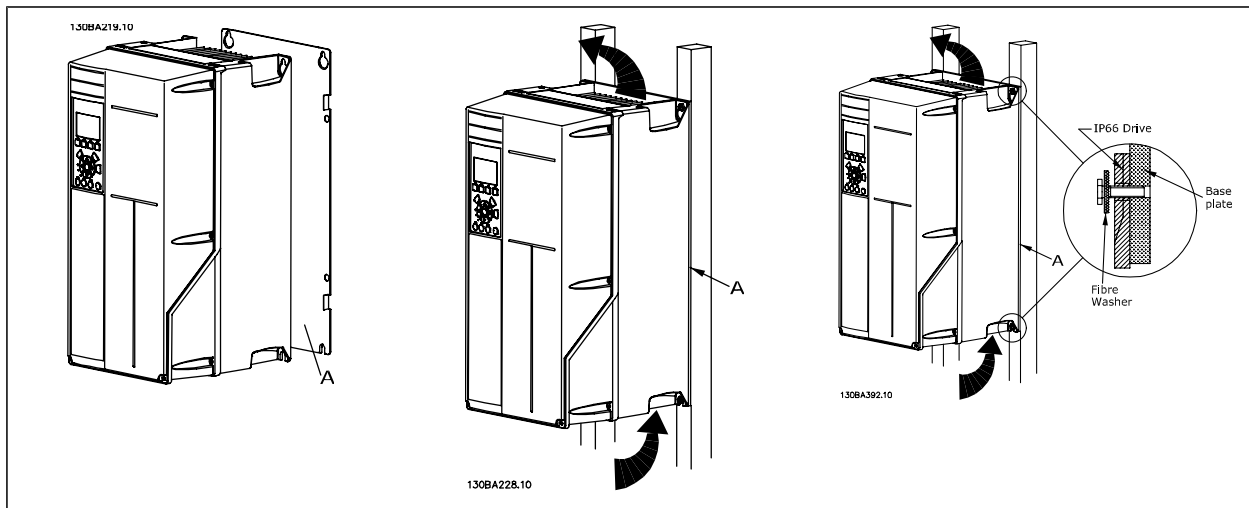



Table 3.3: Mounting frame sizes A5, B1, B2, C1 and C2 on a non-solid back wall, the drive must be provided with a back plate A due to insufficient cooling air over the heat sink.

### 3.2.2 Panel Through Mounting

A Panel Through Mount Kit is available for frequency converter series VLT HVAC FC 102, VLT Aqua Drive and VLT AutomationDrive.

In order to increase heatsink cooling and reduce panel depth, the frequency converter may be mounted in a through panel. Furthermore the in-built fan can then be removed.

The kit is available for enclosures A5 through C2.

	<p><b>NB!</b> This kit cannot be used with cast front covers. No cover or IP21 plastic cover must be used instead.</p>
---	--

Information on ordering numbers is found in the *Design Guide*, section *Ordering Numbers*.

More detailed information is available in the *Panel Through Mount Kit instruction*, *MI.33.H1.YY*, where yy=language code.

### 3.3 Electrical Installation

**NB!**
**Cables General**

All cabling must comply with national and local regulations on cable cross-sections and ambient temperature. Copper (75°C) conductors are recommended.

## 3

#### Aluminium Conductors

Terminals can accept aluminium conductors but the conductor surface has to be clean and the oxidation must be removed and sealed by neutral acid-free Vaseline grease before the conductor is connected.

Furthermore the terminal screw must be retightened after two days due to softness of the aluminium. It is crucial to keep the connection a gas tight joint, otherwise the aluminium surface will oxidize again.

Tightening-up Torque					
Frame size	200 - 240 V	380 - 500 V	525 - 690 V	Cable for:	Tightening up torque
A1	0.25-1.5 kW	0.37-1.5 kW	-	Mains, Brake resistor, load sharing, Motor cables	0.5-0.6 Nm
A2	0.25-2.2 kW	0.37-4 kW	-		
A3	3-3.7 kW	5.5-7.5 kW	-		
A5	3-3.7 kW	5.5-7.5 kW	-		
B1	5.5-7.5 kW	11-15 kW	-	Mains, Brake resistor, load sharing, Motor cables	1.8 Nm
				Relay	0.5-0.6 Nm
				Earth	2-3 Nm
B2	11 kW	18.5-22 kW	11-22 kW	Mains, Brake resistor, load sharing cables	4.5 Nm
				Motor cables	4.5 Nm
				Relay	0.5-0.6 Nm
				Earth	2-3 Nm
B3	5.5-7.5 kW	11-15 kW	-	Mains, Brake resistor, load sharing, Motor cables	1.8 Nm
				Relay	0.5-0.6 Nm
				Earth	2-3 Nm
B4	11-15 kW	18.5-30 kW	-	Mains, Brake resistor, load sharing, Motor cables	4.5 Nm
				Relay	0.5-0.6 Nm
				Earth	2-3 Nm
C1	15-22 kW	30-45 kW	-	Mains, Brake resistor, load sharing cables	10 Nm
				Motor cables	10 Nm
				Relay	0.5-0.6 Nm
				Earth	2-3 Nm
C2	30-37 kW	55-75 kW	30-75 kW	Mains, motor cables	14 Nm (up to 95 mm <sup>2</sup> ) 24 Nm (over 95 mm <sup>2</sup> )
				Load Sharing, brake cables	14 Nm
				Relay	0.5-0.6 Nm
				Earth	2-3 Nm
C3	18.5-22 kW	30-37 kW	-	Mains, Brake resistor, load sharing, Motor cables	10 Nm
				Relay	0.5-0.6 Nm
				Earth	2-3 Nm
C4	37-45 kW	55-75 kW	-	Mains, motor cables	14 Nm (up to 95 mm <sup>2</sup> ) 24 Nm (over 95 mm <sup>2</sup> )
				Load Sharing, brake cables	14 Nm
				Relay	0.5-0.6 Nm
				Earth	2-3 Nm

#### 3.3.1 Removal of Knockouts for Extra Cables

1. Remove cable entry from the frequency converter (Avoiding foreign parts falling into the frequency converter when removing knockouts)
2. Cable entry has to be supported around the knockout you intend to remove.
3. The knockout can now be removed with a strong mandrel and a hammer.
4. Remove burrs from the hole.
5. Mount Cable entry on frequency converter.

### 3.3.2 Connection to Mains and Earthing



**NB!**

The plug connector for power is plugable on frequency converters up to 7.5 kW.

1. Fit the two screws in the de-coupling plate, slide it into place and tighten the screws.
2. Make sure the frequency converter is properly earthed. Connect to earth connection (terminal 95). Use screw from the accessory bag.
3. Place plug connector 91(L1), 92(L2), 93(L3) from the accessory bag onto the terminals labelled MAINS at the bottom of the frequency converter.
4. Attach mains wires to the mains plug connector.
5. Support the cable with the supporting enclosed brackets.

3



**NB!**

Check that mains voltage corresponds to the mains voltage of the name plate.



**IT Mains**

Do not connect 400 V frequency converters with RFI-filters to mains supplies with a voltage between phase and earth of more than 440 V.



The earth connection cable cross section must be at least 10 mm<sup>2</sup> or 2 x rated mains wires terminated separately according to EN 50178.

The mains connection is fitted to the mains switch if this is included.

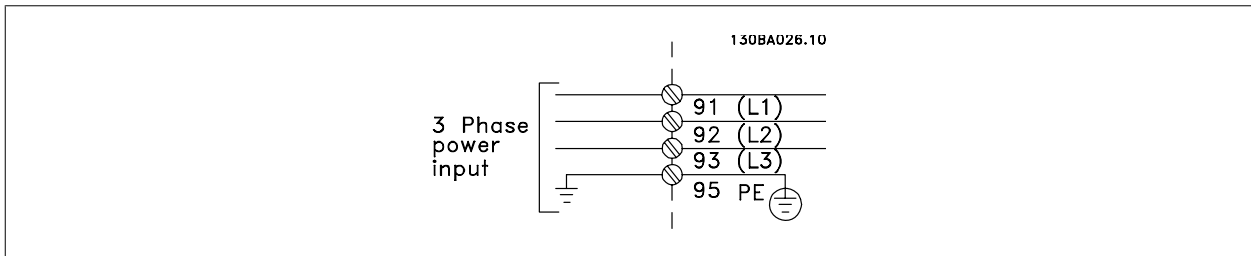

3

Mains connection for frame sizes A1, A2 and A3:

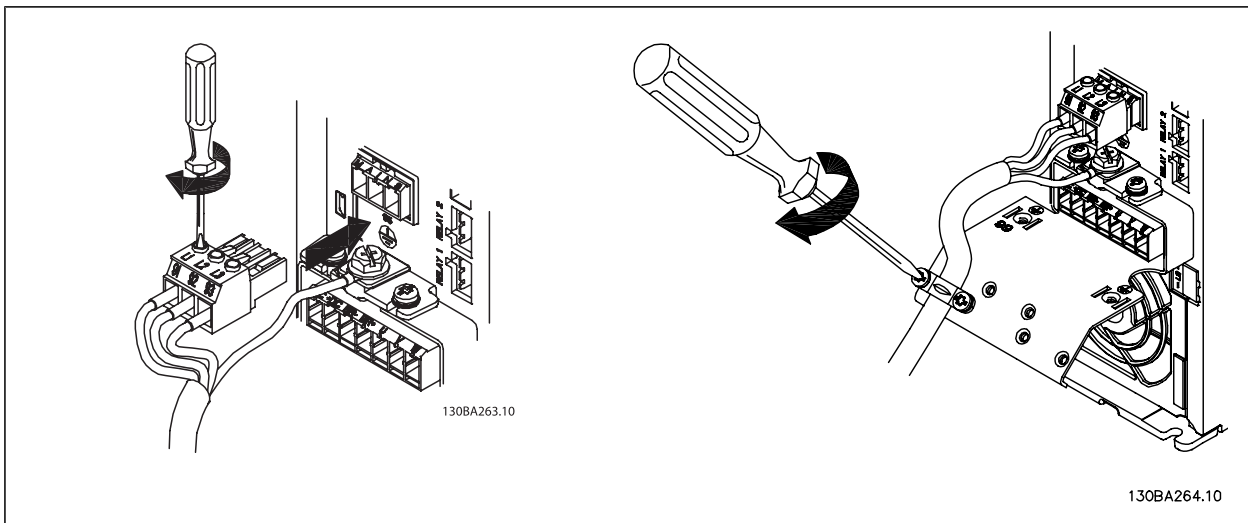
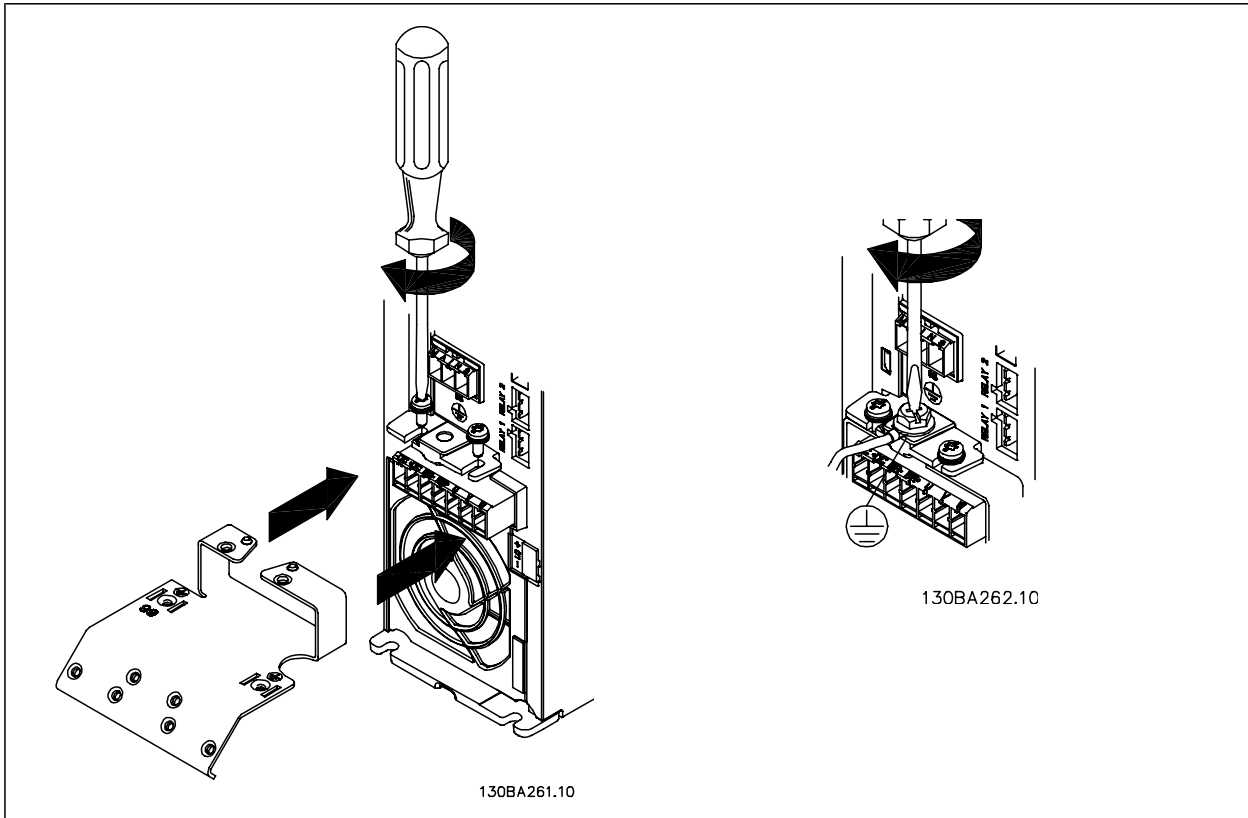

**Mains connector frame size A5 (IP 55/66)**

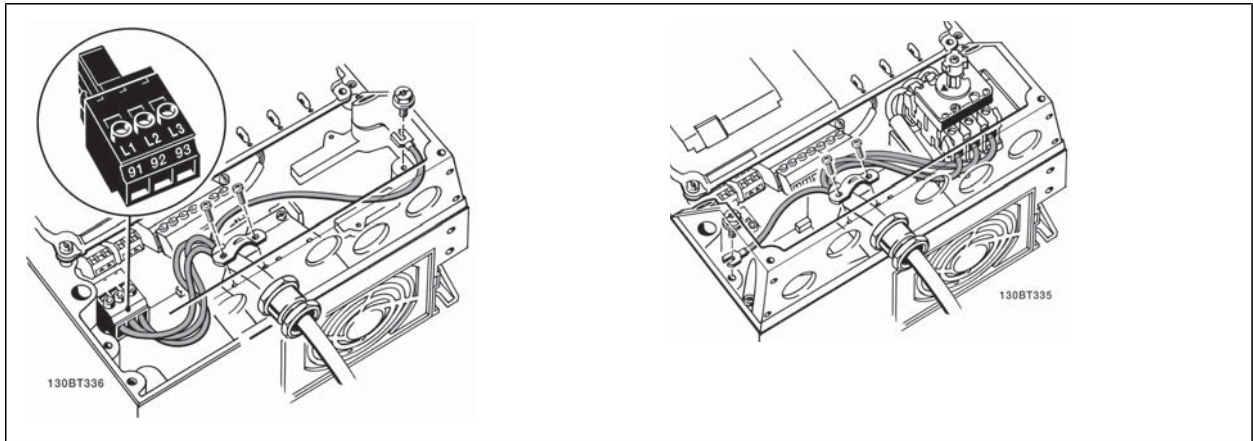

**3**

When disconnecter is used (frame size A5) the PE must be mounted on the left side of the drive.

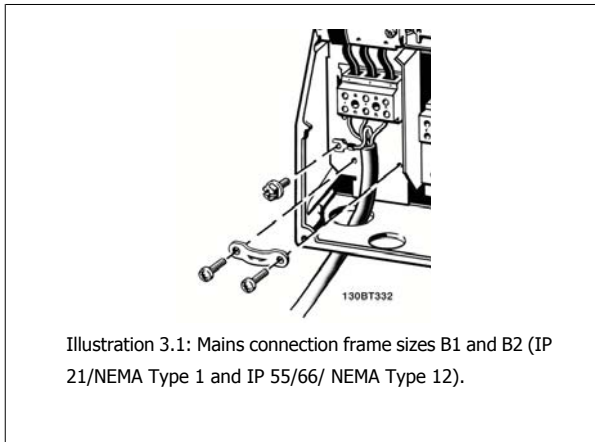

Illustration 3.1: Mains connection frame sizes B1 and B2 (IP 21/NEMA Type 1 and IP 55/66/ NEMA Type 12).

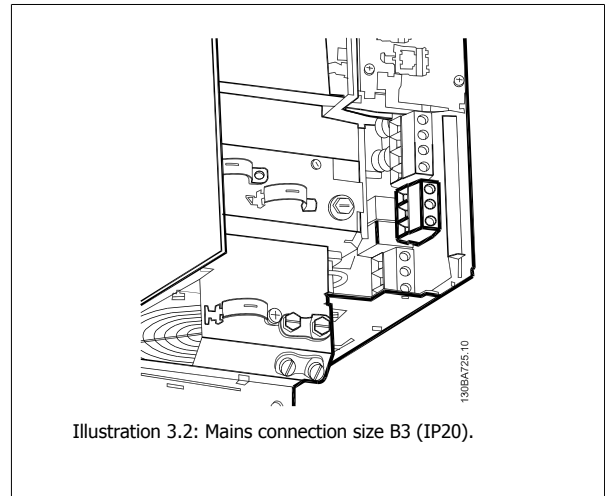

Illustration 3.2: Mains connection size B3 (IP20).

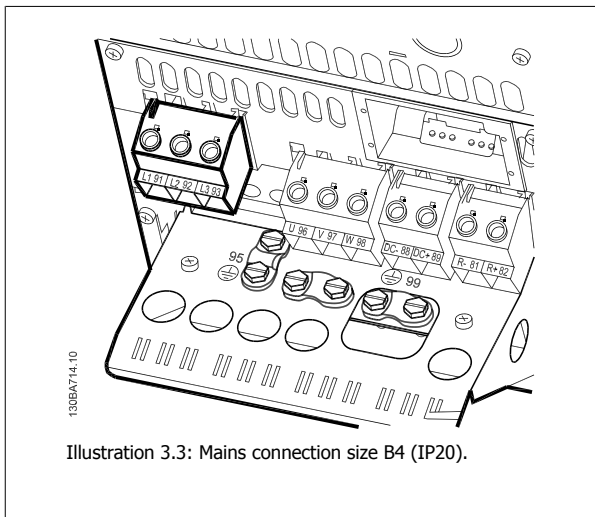

Illustration 3.3: Mains connection size B4 (IP20).

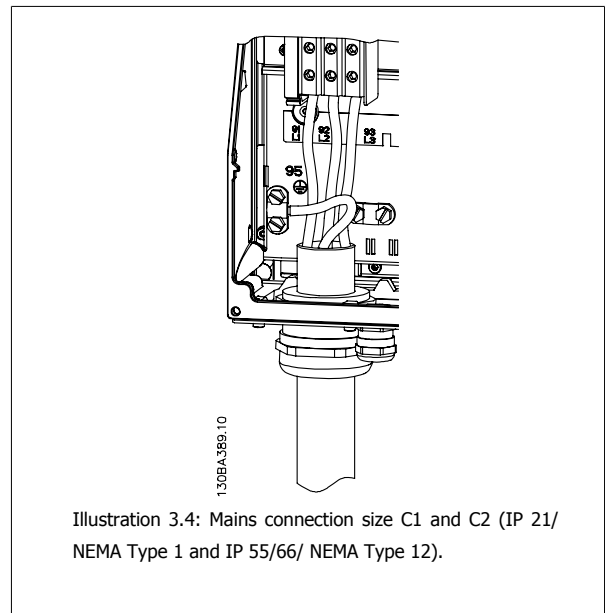

Illustration 3.4: Mains connection size C1 and C2 (IP 21/ NEMA Type 1 and IP 55/66/ NEMA Type 12).

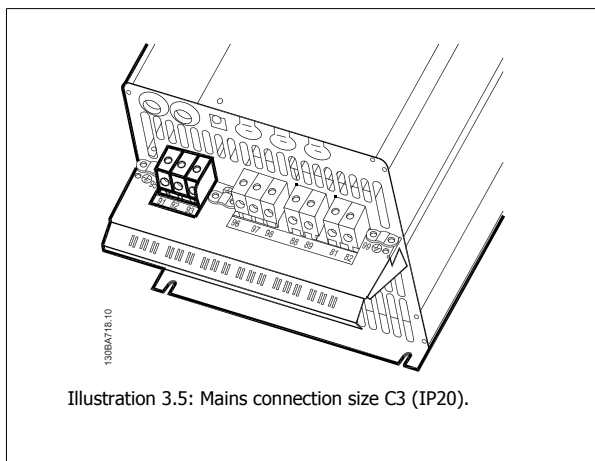

Illustration 3.5: Mains connection size C3 (IP20).

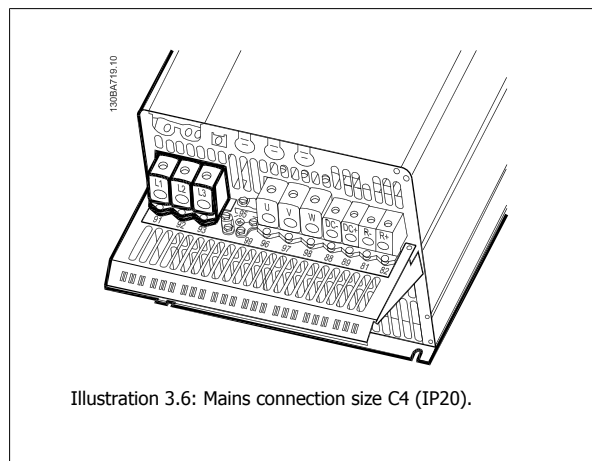

Illustration 3.6: Mains connection size C4 (IP20).

Usually the power cables for mains are unshielded cables.

### 3.3.3 Motor Connection



**NB!**

Motor cable must be screened/armoured. If an unscreened/unarmoured cable is used, some EMC requirements are not complied with. Use a screened/armoured motor cable to comply with EMC emission specifications. For more information, see *EMC Test Results*.

See section General Specifications for correct dimensioning of motor cable cross-section and length.

**Screening of cables:** Avoid installation with twisted screen ends (pigtailed). They spoil the screening effect at higher frequencies. If it is necessary to break the screen to install a motor isolator or motor contactor, the screen must be continued at the lowest possible HF impedance.

Connect the motor cable screen to both the decoupling plate of the frequency converter and to the metal housing of the motor.

Make the screen connections with the largest possible surface area (cable clamp). This is done by using the supplied installation devices in the frequency converter.

If it is necessary to split the screen to install a motor isolator or motor relay, the screen must be continued with the lowest possible HF impedance.

**Cable-length and cross-section:** The frequency converter has been tested with a given length of cable and a given cross-section of that cable. If the cross-section is increased, the cable capacitance - and thus the leakage current - may increase, and the cable length must be reduced correspondingly. Keep the motor cable as short as possible to reduce the noise level and leakage currents.

**Switching frequency:** When frequency converters are used together with Sine-wave filters to reduce the acoustic noise from a motor, the switching frequency must be set according to the Sine-wave filter instruction in par. 14-01 *Switching Frequency*.

1. Fasten decoupling plate to the bottom of the frequency converter with screws and washers from the accessory bag.
2. Attach motor cable to terminals 96 (U), 97 (V), 98 (W).
3. Connect to earth connection (terminal 99) on decoupling plate with screws from the accessory bag.
4. Insert plug connectors 96 (U), 97 (V), 98 (W) (up to 7.5 kW) and motor cable to terminals labelled MOTOR.
5. Fasten screened cable to decoupling plate with screws and washers from the accessory bag.

All types of three-phase asynchronous standard motors can be connected to the frequency converter. Normally, small motors are star-connected (230/400 V, Y). Large motors are normally delta-connected (400/690 V, Δ). Refer to the motor name plate for correct connection mode and voltage.



**3**

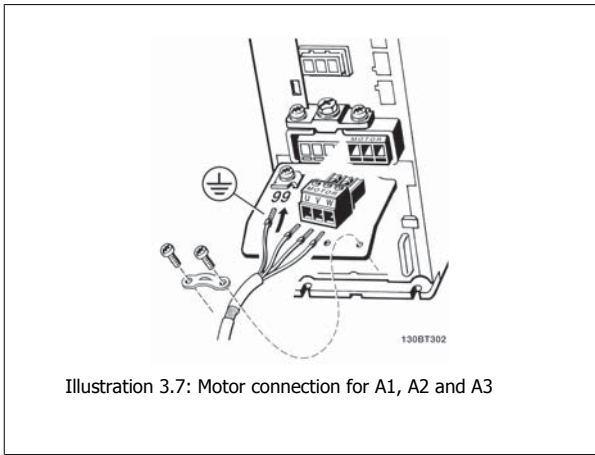

Illustration 3.7: Motor connection for A1, A2 and A3

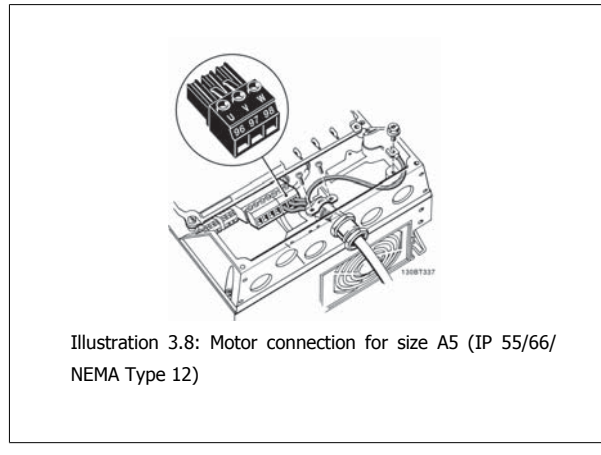

Illustration 3.8: Motor connection for size A5 (IP 55/66/ NEMA Type 12)

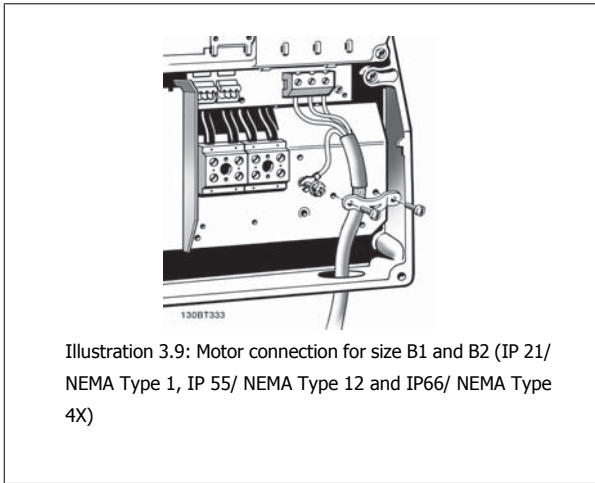

Illustration 3.9: Motor connection for size B1 and B2 (IP 21/ NEMA Type 1, IP 55/ NEMA Type 12 and IP66/ NEMA Type 4X)

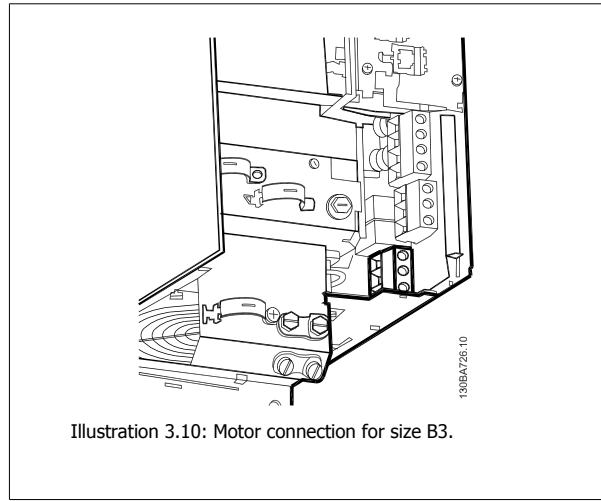

Illustration 3.10: Motor connection for size B3.

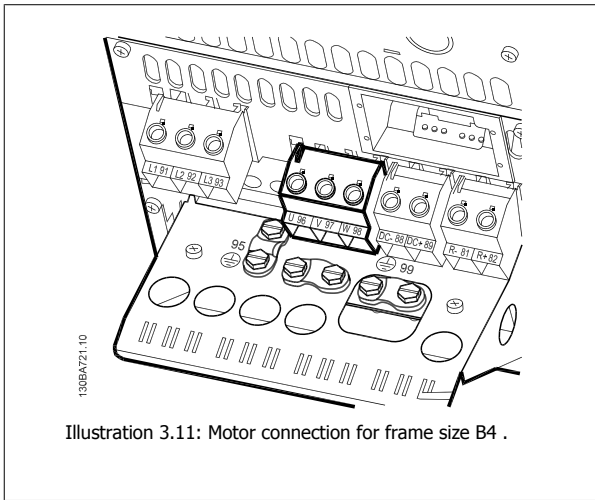

Illustration 3.11: Motor connection for frame size B4 .

3

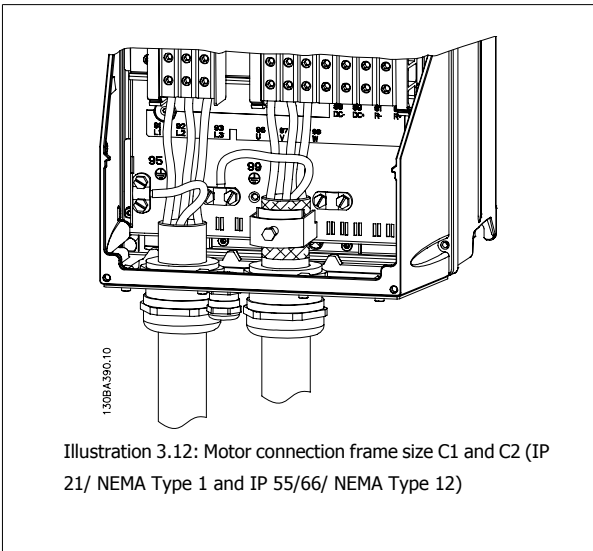

Illustration 3.12: Motor connection frame size C1 and C2 (IP 21/ NEMA Type 1 and IP 55/66/ NEMA Type 12)

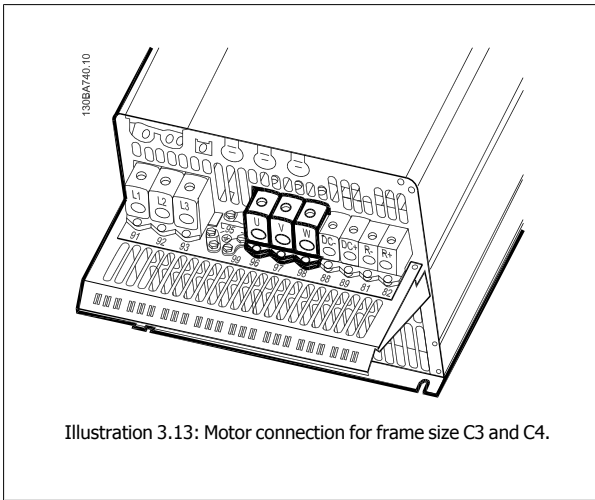

Illustration 3.13: Motor connection for frame size C3 and C4.

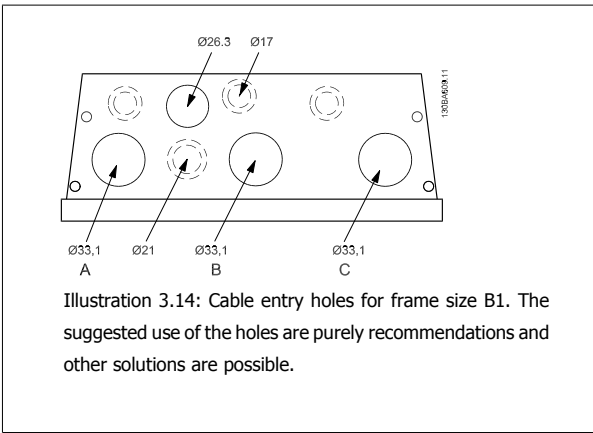

Illustration 3.14: Cable entry holes for frame size B1. The suggested use of the holes are purely recommendations and other solutions are possible.

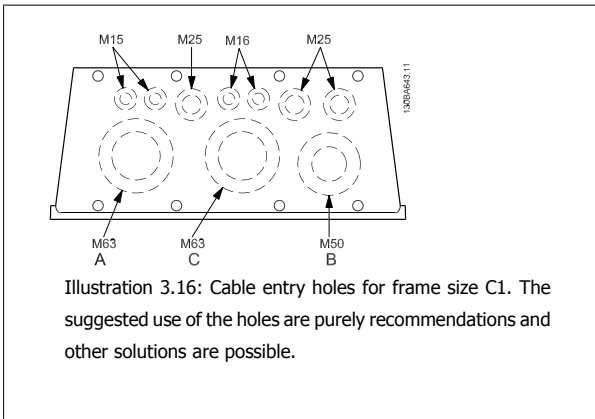

Illustration 3.16: Cable entry holes for frame size C1. The suggested use of the holes are purely recommendations and other solutions are possible.

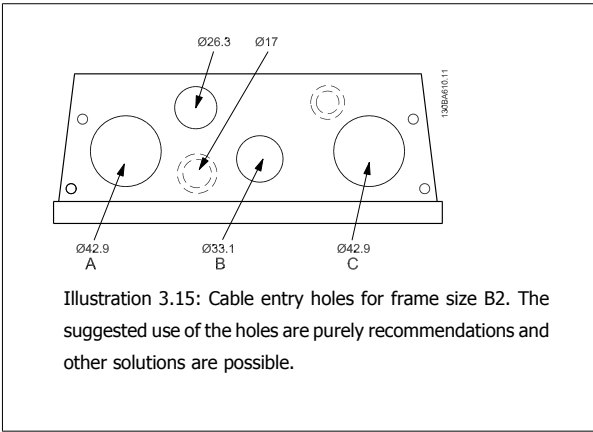

Illustration 3.15: Cable entry holes for frame size B2. The suggested use of the holes are purely recommendations and other solutions are possible.

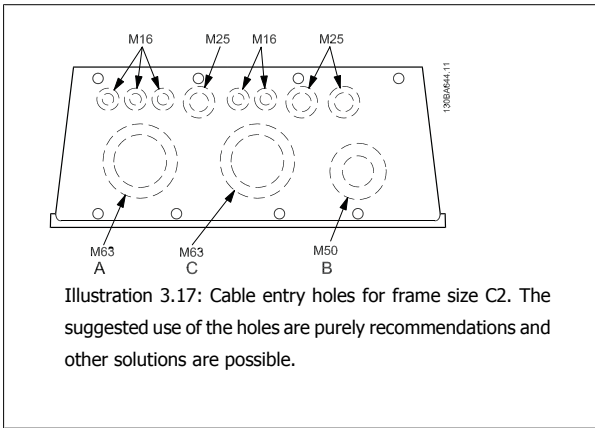
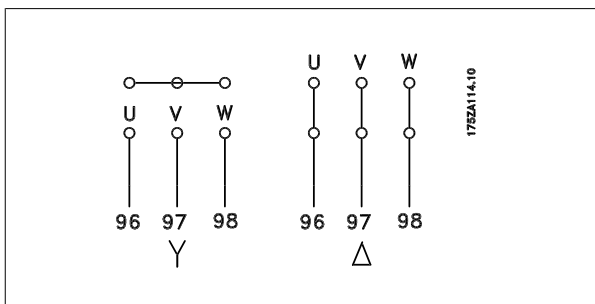



Illustration 3.17: Cable entry holes for frame size C2. The suggested use of the holes are purely recommendations and other solutions are possible.

Term. no.	96	97	98	99	
	U	V	W	PE <sup>1)</sup>	Motor voltage 0-100% of mains voltage.
	U1	V1	W1	PE <sup>1)</sup>	3 wires out of motor
	U2	V2	W2	PE <sup>1)</sup>	Delta-connected
	U1	V1	W1	PE <sup>1)</sup>	6 wires out of motor
					Star-connected U2, V2, W2
					U2, V2 and W2 to be interconnected separately.

<sup>1)</sup>Protected Earth Connection



**NB!**  
 In motors without phase insulation paper or other insulation reinforcement suitable for operation with voltage supply (such as a frequency converter), fit a Sine-wave filter on the output of the frequency converter.

**3**

**3.3.4 Fuses**

**Branch circuit protection:**

In order to protect the installation against electrical and fire hazard, all branch circuits in an installation, switch gear, machines etc., must be short-circuited and overcurrent protected according to national/international regulations.

**Short-circuit protection:**

The frequency converter must be protected against short-circuit to avoid electrical or fire hazard. Danfoss recommends using the fuses mentioned below to protect service personnel and equipment in case of an internal failure in the drive. The frequency converter provides full short-circuit protection in case of a short-circuit on the motor output.

**Overcurrent protection:**

Provide overload protection to avoid fire hazard due to overheating of the cables in the installation. The frequency converter is equipped with an internal overcurrent protection that can be used for upstream overload protection (UL-applications excluded). See par. 4-18 *Current Limit*. Moreover, fuses or circuit breakers can be used to provide the overcurrent protection in the installation. Overcurrent protection must always be carried out according to national regulations.

Fuses must be designed for protection in a circuit capable of supplying a maximum of 100,000 A<sub>rms</sub> (symmetrical), 500 V maximum.

**Non UL compliance**

If UL/cUL is not to be complied with, we recommend using the following fuses, which will ensure compliance with EN50178:

In case of malfunction, not following the recommendation may result in unnecessary damage to the frequency converter.

FC Type	Max. fuse size <sup>1)</sup>	Min. rated Voltage	Type
K25-K75	10A	200-240 V	type gG
1K1-2K2	20A	200-240 V	type gG
3K0-3K7	32A	200-240 V	type gG
5K5-7K5	63A	200-240 V	type gG
11K	80A	200-240 V	type gG
15K-18K5	125A	200-240 V	type gG
22K	160A	200-240 V	type aR
30K	200A	200-240 V	type aR
37K	250A	200-240 V	type aR

1) Max. fuses - refer to national/international regulations to select an appropriate fuse size.

FC Type	Max. fuse size <sup>1)</sup>	Min. rated Voltage	Type
K37-1K5	10A	380-500 V	type gG
2K2-4K0	20A	380-500 V	type gG
5K5-7K5	32A	380-500 V	type gG
11K-18K	63A	380-500 V	type gG
22K	80A	380-500 V	type gG
30K	100A	380-500 V	type gG
37K	125A	380-500 V	type gG
45K	160A	380-500 V	type aR
55K-75K	250A	380-500 V	type aR

## UL Compliance

## 200-240 V

FC Type	Bussmann	Bussmann	Bussmann	Bussmann	Bussmann	Bussmann
kW	Type RK1	Type J	Type T	Type CC	Type CC	Type CC
K25-K37	KTN-R05	JKS-05	JJN-06	FNQ-R-5	KTK-R-5	LP-CC-5
K55-1K1	KTN-R10	JKS-10	JJN-10	FNQ-R-10	KTK-R-10	LP-CC-10
1K5	KTN-R15	JKS-15	JJN-15	FNQ-R-15	KTK-R-15	LP-CC-15
2K2	KTN-R20	JKS-20	JJN-20	FNQ-R-20	KTK-R-20	LP-CC-20
3K0	KTN-R25	JKS-25	JJN-25	FNQ-R-25	KTK-R-25	LP-CC-25
3K7	KTN-R30	JKS-30	JJN-30	FNQ-R-30	KTK-R-30	LP-CC-30
5K5	KTN-R50	KS-50	JJN-50	-	-	-
7K5	KTN-R60	JKS-60	JJN-60	-	-	-
11K	KTN-R80	JKS-80	JJN-80	-	-	-
15K-18K5	KTN-R125	JKS-150	JJN-125	-	-	-

FC Type	SIBA	Littel fuse	Ferraz-Shawmut	Ferraz-Shawmut
kW	Type RK1	Type RK1	Type CC	Type RK1
K25-K37	5017906-005	KLN-R05	ATM-R05	A2K-05R
K55-1K1	5017906-010	KLN-R10	ATM-R10	A2K-10R
1K5	5017906-016	KLN-R15	ATM-R15	A2K-15R
2K2	5017906-020	KLN-R20	ATM-R20	A2K-20R
3K0	5017906-025	KLN-R25	ATM-R25	A2K-25R
3K7	5012406-032	KLN-R30	ATM-R30	A2K-30R
5K5	5014006-050	KLN-R50	-	A2K-50R
7K5	5014006-063	KLN-R60	-	A2K-60R
11K	5014006-080	KLN-R80	-	A2K-80R
15K-18K5	2028220-125	KLN-R125	-	A2K-125R

FC Type	Bussmann	SIBA	Littel fuse	Ferraz-Shawmut
kW	Type JFHR2	Type RK1	JFHR2	JFHR2
22K	FWX-150	2028220-150	L25S-150	A25X-150
30K	FWX-200	2028220-200	L25S-200	A25X-200
37K	FWX-250	2028220-250	L25S-250	A25X-250

KTS-fuses from Bussmann may substitute KTN for 240 V frequency converters.

FWH-fuses from Bussmann may substitute FWX for 240 V frequency converters.

KLSR fuses from LITTEL FUSE may substitute KLSR fuses for 240 V frequency converters.

L50S fuses from LITTEL FUSE may substitute L50S fuses for 240 V frequency converters.

A6KR fuses from FERRAZ SHAWMUT may substitute A2KR for 240 V frequency converters.

A50X fuses from FERRAZ SHAWMUT may substitute A25X for 240 V frequency converters.

## 380-500 V

FC Type	Bussmann	Bussmann	Bussmann	Bussmann	Bussmann	Bussmann
kW	Type RK1	Type J	Type T	Type CC	Type CC	Type CC
K37-1K1	KTS-R6	JKS-6	JJS-6	FNQ-R-6	KTK-R-6	LP-CC-6
1K5-2K2	KTS-R10	JKS-10	JJS-10	FNQ-R-10	KTK-R-10	LP-CC-10
3K0	KTS-R15	JKS-15	JJS-15	FNQ-R-15	KTK-R-15	LP-CC-15
4K0	KTS-R20	JKS-20	JJS-20	FNQ-R-20	KTK-R-20	LP-CC-20
5K5	KTS-R25	JKS-25	JJS-25	FNQ-R-25	KTK-R-25	LP-CC-25
7K5	KTS-R30	JKS-30	JJS-30	FNQ-R-30	KTK-R-30	LP-CC-30
11K	KTS-R40	JKS-40	JJS-40	-	-	-
15K	KTS-R50	JKS-50	JJS-50	-	-	-
18K	KTS-R60	JKS-60	JJS-60	-	-	-
22K	KTS-R80	JKS-80	JJS-80	-	-	-
30K	KTS-R100	JKS-100	JJS-100	-	-	-
37K	KTS-R125	JKS-150	JJS-150	-	-	-
45K	KTS-R150	JKS-150	JJS-150	-	-	-

FC Type	SIBA	Littel fuse	Ferraz-Shawmut	Ferraz-Shawmut
kW	Type RK1	Type RK1	Type CC	Type RK1
K37-1K1	5017906-006	KLS-R6	ATM-R6	A6K-6R
1K5-2K2	5017906-010	KLS-R10	ATM-R10	A6K-10R
3K0	5017906-016	KLS-R15	ATM-R15	A6K-15R
4K0	5017906-020	KLS-R20	ATM-R20	A6K-20R
5K5	5017906-025	KLS-R25	ATM-R25	A6K-25R
7K5	5012406-032	KLS-R30	ATM-R30	A6K-30R
11K	5014006-040	KLS-R40	-	A6K-40R
15K	5014006-050	KLS-R50	-	A6K-50R
18K	5014006-063	KLS-R60	-	A6K-60R
22K	2028220-100	KLS-R80	-	A6K-80R
30K	2028220-125	KLS-R100	-	A6K-100R
37K	2028220-125	KLS-R125	-	A6K-125R
45K	2028220-160	KLS-R150	-	A6K-150R

FC Type	Bussmann	Bussmann	Bussmann	Bussmann
kW	JFHR2	Type H	Type T	JFHR2
55K	FWH-200	-	-	-
75K	FWH-250	-	-	-

FC Type	SIBA	Littel fuse	Ferraz-Shawmut	Ferraz-Shawmut
kW	Type RK1	JFHR2	JFHR2	JFHR2
55K	2028220-200	L50S-225	-	A50-P225
75K	2028220-250	L50S-250	-	A50-P250

Ferraz-Shawmut A50QS fuses may be substituted for A50P fuses.

170M fuses shown from Bussmann use the -/80 visual indicator. -TN/80 Type T, -/110 or TN/110 Type T indicator fuses of the same size and amperage may be substituted.

**550 - 600V**

FC Type	Bussmann	Bussmann	Bussmann	Bussmann	Bussmann	Bussmann
kW	Type RK1	Type J	Type T	Type CC	Type CC	Type CC
K75-1K5	KTS-R-5	JKS-5	JJS-6	FNQ-R-5	KTK-R-5	LP-CC-5
2K2-4K0	KTS-R10	JKS-10	JJS-10	FNQ-R-10	KTK-R-10	LP-CC-10
5K5-7K5	KTS-R20	JKS-20	JJS-20	FNQ-R-20	KTK-R-20	LP-CC-20

FC Type	SIBA	Littel fuse	Ferraz-Shawmut
kW	Type RK1	Type RK1	Type RK1
K75-1K5	5017906-005	KLSR005	A6K-5R
2K2-4K0	5017906-010	KLSR010	A6K-10R
5K5-7K5	5017906-020	KLSR020	A6K-20R

FC Type	Bussmann	SIBA	Ferraz-Shawmut
kW	JFHR2	Type RK1	Type RK1
P37K	170M3013	2061032.125	6.6URD30D08A0125
P45K	170M3014	2061032.160	6.6URD30D08A0160
P55K	170M3015	2061032.200	6.6URD30D08A0200
P75K	170M3015	2061032.200	6.6URD30D08A0200

170M fuses shown from Bussmann use the -/80 visual indicator. -TN/80 Type T, -/110 or TN/110 Type T indicator fuses of the same size and amperage may be substituted.

170M fuses from Bussmann when provided in the 525-600/690 V FC-302 P37K-P75K, FC-102 P75K, or FC-202 P45K-P90K drives are 170M3015.

170M fuses from Bussmann when provided in the 525-600/690V FC-302 P90K-P132, FC-102 P90K-P132, or FC-202 P110-P160 drives are 170M3018.

170M fuses from Bussmann when provided in the 525-600/690V FC-302 P160-P315, FC-102 P160-P315, or FC-202 P200-P400 drives are 170M5011.

### 3.3.5 Access to Control Terminals

3

All terminals to the control cables are located underneath the terminal cover on the front of the frequency converter. Remove the terminal cover with a screwdriver.

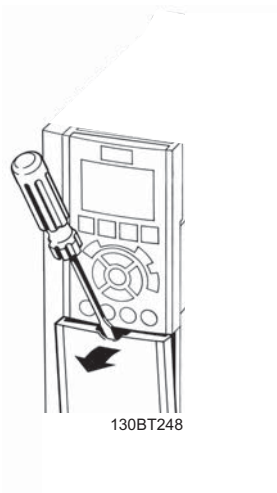

Illustration 3.18: Access to control terminals for A2, A3, B3, B4, C3 and C4 enclosures

Remove front-cover to access control terminals. When replacing the front-cover, please ensure proper fastening by applying a torque of 2 Nm.

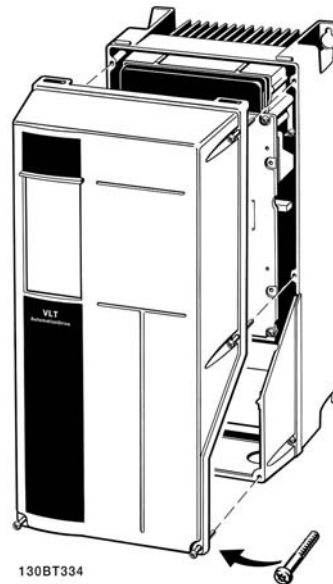

Illustration 3.19: Access to control terminals for A5, B1, B2, C1 and C2 enclosures

### 3.3.6 Electrical Installation, Control Terminals

**To mount the cable to the terminal:**

1. Strip insulation of 9-10 mm
2. Insert a screwdriver<sup>1)</sup> in the square hole.
3. Insert the cable in the adjacent circular hole.
4. Remove the screw driver. The cable is now mounted to the terminal.

**To remove the cable from the terminal:**

1. Insert a screwdriver<sup>1)</sup> in the square hole.
2. Pull out the cable.

<sup>1)</sup> Max. 0.4 x 2.5 mm

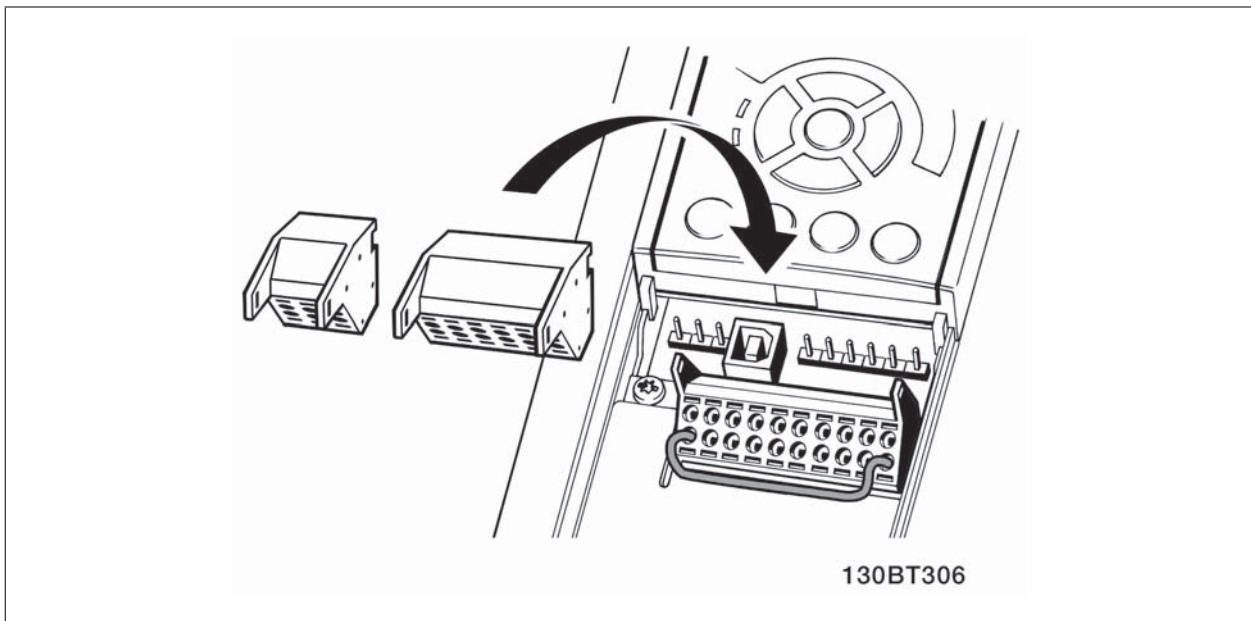
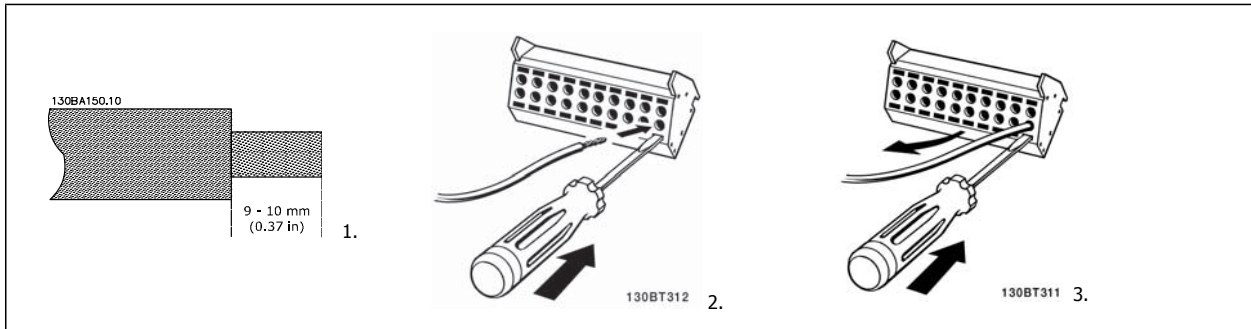

### 3.4 Connection Examples

#### 3.4.1 Start/Stop

- Terminal 18 = par. 5-10 *Terminal 18 Digital Input* [8] *Start*
- Terminal 27 = par. 5-12 *Terminal 27 Digital Input* [0] *No operation* (Default *coast inverse*)
- Terminal 37 = Safe stop (where available!)

3

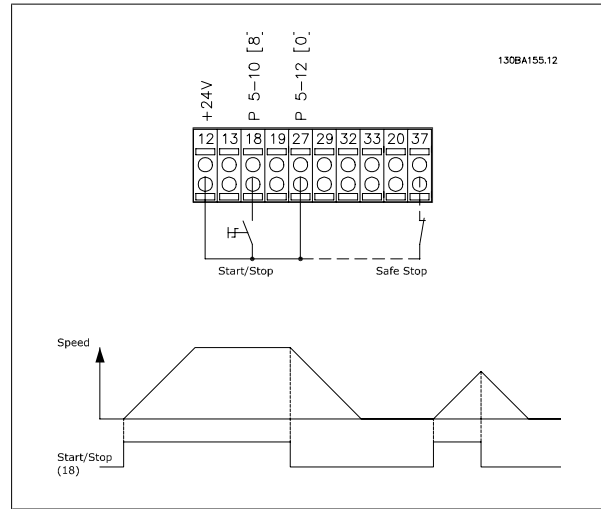

#### 3.4.2 Pulse Start/Stop

- Terminal 18 = par. 5-10 *Terminal 18 Digital Input* Latched start, [9]
- Terminal 27 = par. 5-12 *Terminal 27 Digital Input* Stop inverse, [6]
- Terminal 37 = Safe stop (where available!)

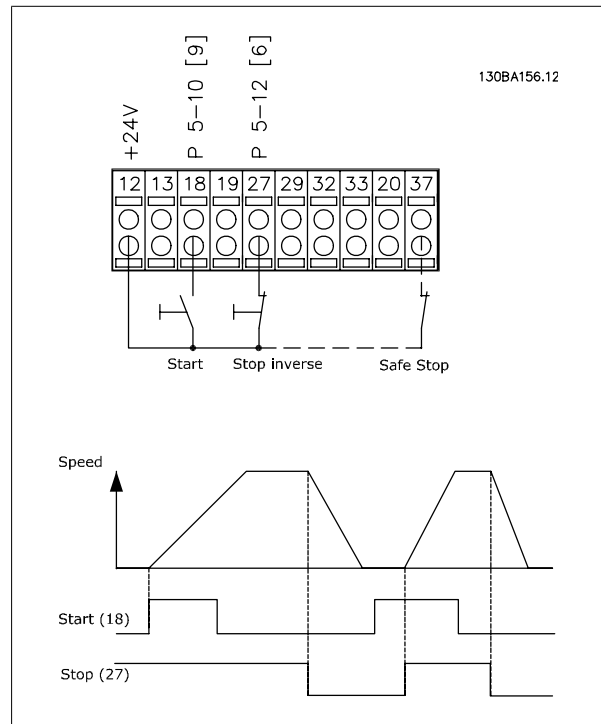



### 3.4.3 Speed Up/Down

**Terminals 29/32 = Speed up/down:**

Terminal 18 = par. 5-10 *Terminal 18 Digital Input* Start [9] (default)

Terminal 27 = par. 5-12 *Terminal 27 Digital Input* Freeze reference [19]

Terminal 29 = par. 5-13 *Terminal 29 Digital Input* Speed up [21]

Terminal 32 = par. 5-14 *Terminal 32 Digital Input* Speed down [22]

NOTE: Terminal 29 only in FC x02 (x=series type).

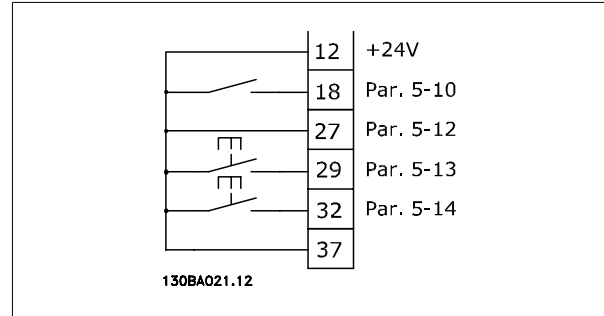

### 3.4.4 Potentiometer Reference

**Voltage reference via a potentiometer:**

Reference Source 1 = [1] *Analog input 53* (default)

Terminal 53, Low Voltage = 0 Volt

Terminal 53, High Voltage = 10 Volt

Terminal 53, Low Ref./Feedback = 0 RPM

Terminal 53, High Ref./Feedback = 1500 RPM

Switch S201 = OFF (U)

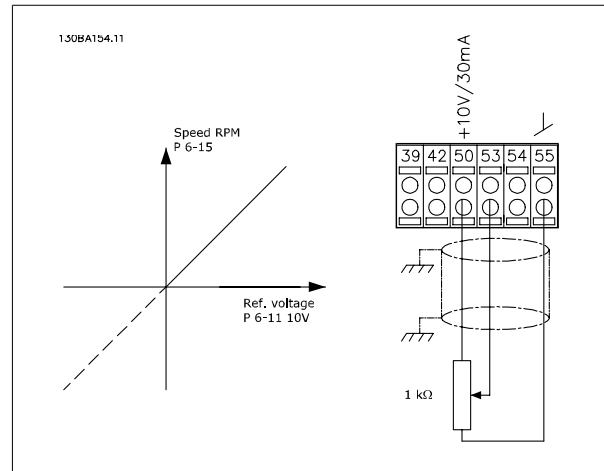

### 3.5.1 Electrical Installation, Control Cables

3

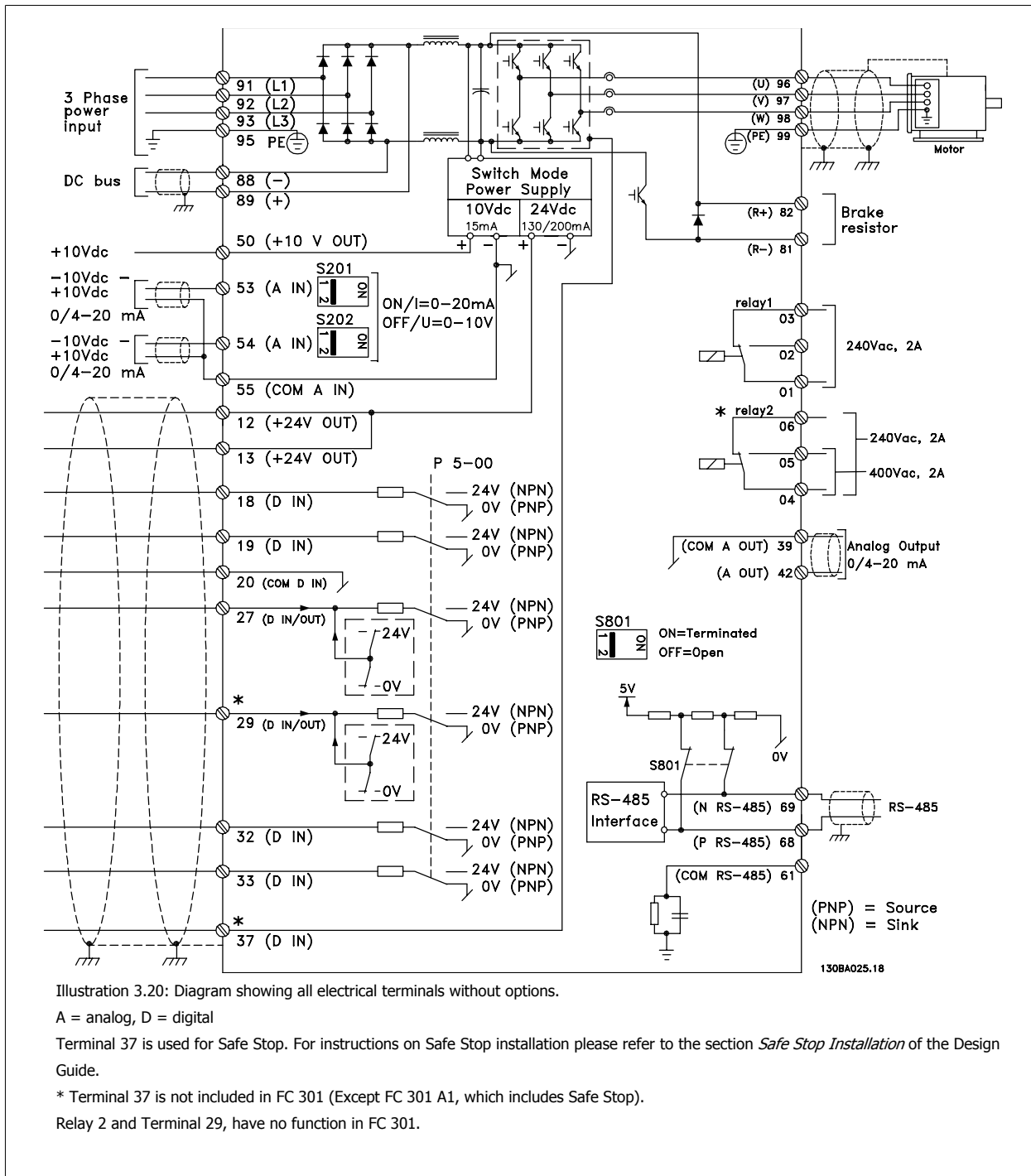

Very long control cables and analogue signals may in rare cases and depending on installation result in 50/60 Hz earth loops due to noise from mains supply cables.

If this occurs, it may be necessary to break the screen or insert a 100 nF capacitor between screen and chassis.

The digital and analogue inputs and outputs must be connected separately to the common inputs (terminal 20, 55, 39) of the frequency converter to avoid ground currents from both groups to affect other groups. For example, switching on the digital input may disturb the analog input signal.

**Input polarity of control terminals**

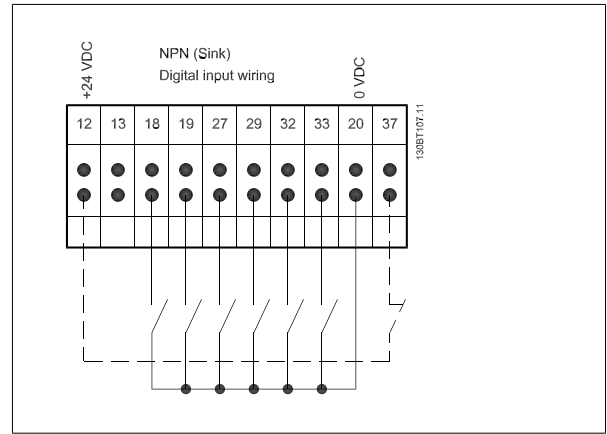
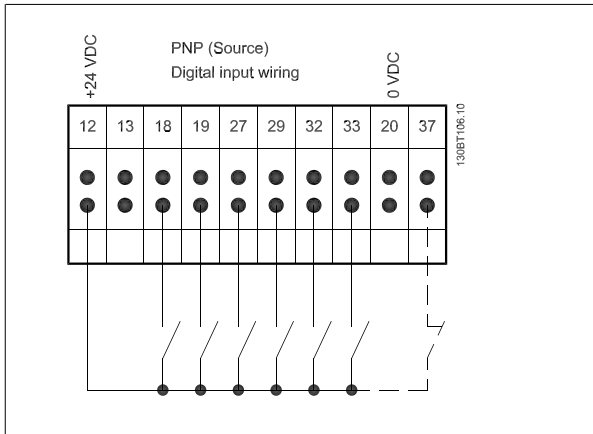

**3**

**NB!**  
Control cables must be screened/armoured.

See section entitled *Earthing of Screened/Armoured Control Cables* for the correct termination of control cables.

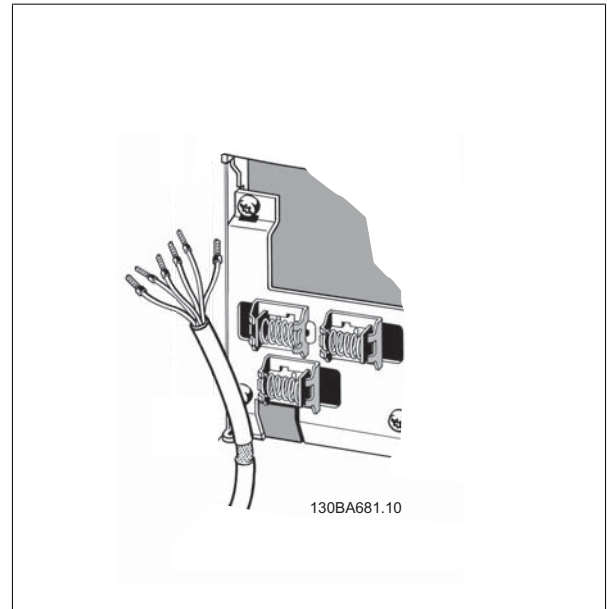

### 3.5.2 Switches S201, S202, and S801

Switches S201 (A53) and S202 (A54) are used to select a current (0-20 mA) or a voltage (-10 to 10 V) configuration of the analog input terminals 53 and 54 respectively.

Switch S801 (BUS TER.) can be used to enable termination on the RS-485 port (terminals 68 and 69).

See drawing *Diagram showing all electrical terminals* in section *Electrical Installation*.

# 3

#### Default setting:

S201 (A53) = OFF (voltage input)

S202 (A54) = OFF (voltage input)

S801 (Bus termination) = OFF



#### NB!

When changing the function of S201, S202 or S801 be careful not to use force for the switch over. It is recommended to remove the LCP fixture (cradle) when operating the switches. The switches must not be operated with power on the frequency converter.

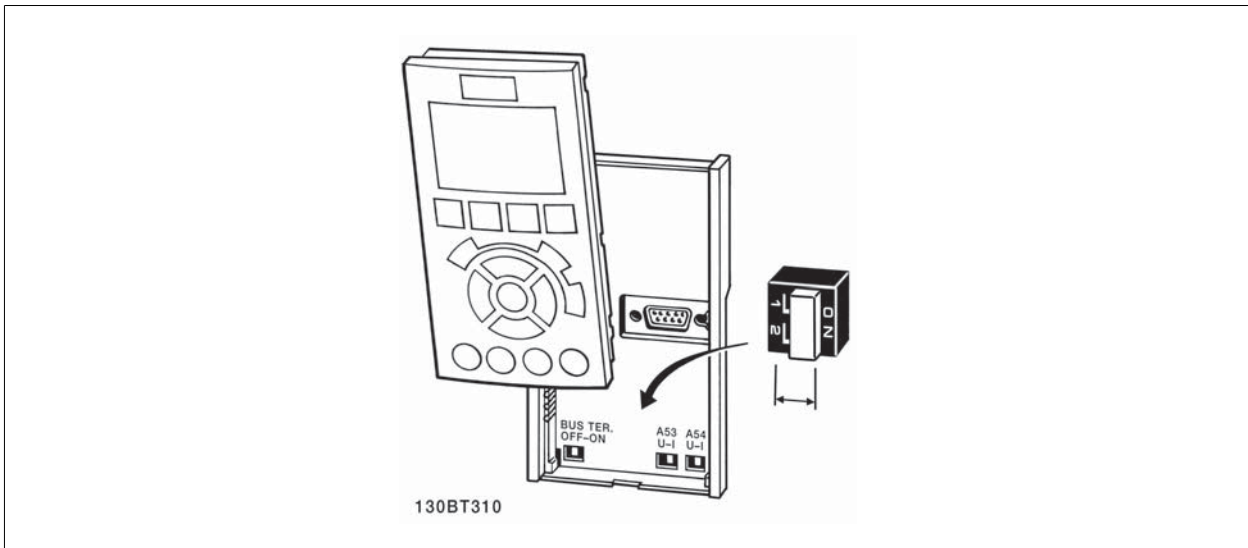

To test the set-up and ensure that the frequency converter is running, follow these steps.

**Step 1. Locate the motor name plate**

**NB!**  
The motor is either star- (Y) or delta- connected (Δ). This information is located on the motor name plate data.

3 ~ MOTOR NR. 1827421		2003	
S/E005A9			
	1,5	kW	
n <sub>2</sub>	31,5	/min.	400 Y V
n <sub>1</sub>	1400	/min.	50 Hz
cos φ	0,80	3,6 A	
1,7L			
B	IP 65	H1/1A	

130BT307

**Step 2. Enter the motor name plate data in this parameter list.**

To access this list first press the [QUICK MENU] key then select "Q2 Quick Setup".

1.	Par.1-20 <i>Motor Power [kW]</i> Par. 1-21 <i>Motor Power [HP]</i>
2.	Par. 1-22 <i>Motor Voltage</i>
3.	Par.1-23 <i>Motor Frequency</i>
4.	Par. 1-24 <i>Motor Current</i>
5.	Par. 1-25 <i>Motor Nominal Speed</i>

**Step 3. Activate the Automatic Motor Adaptation (AMA)**

Performing an AMA will ensure optimum performance. The AMA measures the values from the motor model equivalent diagram.

1. Connect terminal 37 to terminal 12 (if terminal 37 is available).
2. Connect terminal 27 to terminal 12 or set par. 5-12 *Terminal 27 Digital Input* to 'No function'.
3. Activate the AMA par. 1-29 *Automatic Motor Adaptation (AMA)*.
4. Choose between complete or reduced AMA. If a Sine-wave filter is mounted, run only the reduced AMA, or remove the Sine-wave filter during the AMA procedure.
5. Press the [OK] key. The display shows "Press [Hand on] to start".
6. Press the [Hand on] key. A progress bar indicates if the AMA is in progress.

**Stop the AMA during operation**

1. Press the [OFF] key - the frequency converter enters into alarm mode and the display shows that the AMA was terminated by the user.

**Successful AMA**

1. The display shows "Press [OK] to finish AMA".
2. Press the [OK] key to exit the AMA state.

**Unsuccessful AMA**

1. The frequency converter enters into alarm mode. A description of the alarm can be found in the *Warnings and Alarms* chapter.
2. "Report Value" in the [Alarm Log] shows the last measuring sequence carried out by the AMA, before the frequency converter entered alarm mode. This number along with the description of the alarm will assist you in troubleshooting. If you contact Danfoss for service, make sure to mention number and alarm description.

**NB!**

Unsuccessful AMA is often caused by incorrectly registered motor name plate data or a too big difference between the motor power size and the frequency converter power size.

3

**Step 4. Set speed limit and ramp times**

Par.3-02 *Minimum Reference*  
 Par.3-03 *Maximum Reference*

Table 3.4: Set up the desired limits for speed and ramp time.

Par. 4-11 *Motor Speed Low Limit [RPM]* or par. 4-12 *Motor Speed Low Limit [Hz]*  
 Par. 4-13 *Motor Speed High Limit [RPM]* or par. 4-14 *Motor Speed High Limit [Hz]*

Par.3-41 *Ramp 1 Ramp up Time*  
 Par.3-42 *Ramp 1 Ramp Down Time*

### 3.7 Additional Connections

#### 3.7.1 Mechanical Brake Control

In hoisting/lowering applications, it is necessary to be able to control an electro-mechanical brake:

- Control the brake using any relay output or digital output (terminal 27 or 29).
- Keep the output closed (voltage-free) as long as the frequency converter is unable to 'support' the motor, for example due to the load being too heavy.
- Select *Mechanical brake control* [32] in par. 5-4\* for applications with an electro-mechanical brake.
- The brake is released when the motor current exceeds the preset value in par.2-20 *Release Brake Current*.
- The brake is engaged when the output frequency is less than the frequency set in par.2-21 *Activate Brake Speed [RPM]* or par.2-22 *Activate Brake Speed [Hz]*, and only if the frequency converter carries out a stop command.

If the frequency converter is in alarm mode or in an over-voltage situation, the mechanical brake immediately cuts in.

#### 3.7.2 Parallel Connection of Motors

The frequency converter can control several parallel-connected motors. The total current consumption of the motors must not exceed the rated output current  $I_{M,N}$  for the frequency converter.

 **NB!**  
Installations with cables connected in a common joint as in the illustration below, is only recommended for short cable lengths.

 **NB!**  
When motors are connected in parallel, par. 1-29 *Automatic Motor Adaptation (AMA)* cannot be used.

 **NB!**  
The electronic thermal relay (ETR) of the frequency converter cannot be used as motor protection for the individual motor in systems with parallel-connected motors. Provide further motor protection by e.g. thermistors in each motor or individual thermal relays (circuit breakers are not suitable as protection).

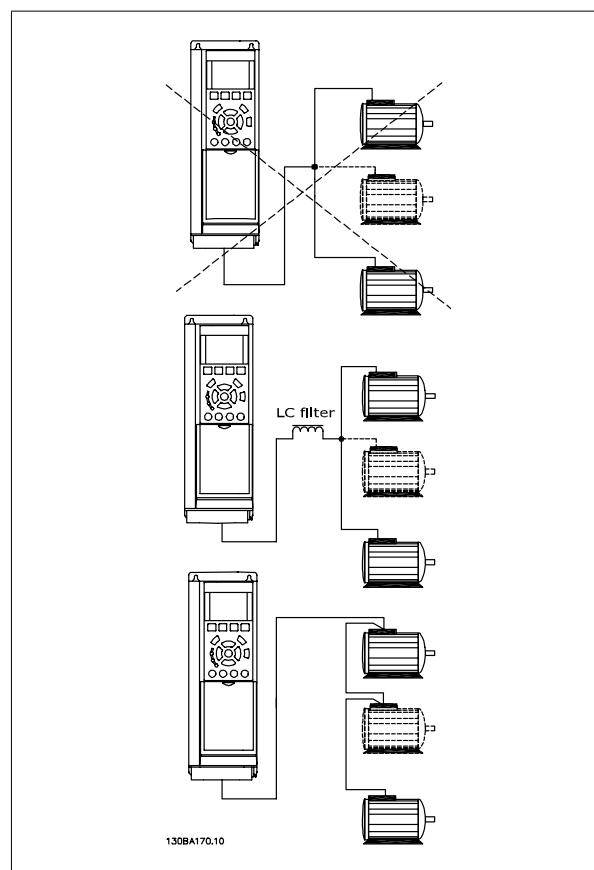

Problems may arise at start and at low RPM values if motor sizes are widely different because small motors' relatively high ohmic resistance in the stator calls for a higher voltage at start and at low RPM values.

#### 3.7.3 Motor Thermal Protection

The electronic thermal relay in the frequency converter has received UL-approval for single motor protection, when par.1-90 *Motor Thermal Protection* is set for *ETR Trip* and par. 1-24 *Motor Current* is set to the rated motor current (see motor name plate).

For thermal motor protection it is also possible to use the MCB 112 PTC Thermistor Card option. This card provides ATEX certificate to protect motors in explosion hazardous areas, Zone 1/21 and Zone 2/22. Please refer to the *Design Guide* for further information.

### 3.7.4 How to Connect a PC to the Frequency Converter

To control the frequency converter from a PC, install the MCT 10 Set-up Software.

The PC is connected via a standard (host/device) USB cable, or via the RS485 interface as shown in the section *Bus Connection* in the Programming Guide.

3



**NB!**

The USB connection is galvanically isolated from the supply voltage (PELV) and other high-voltage terminals. The USB connection is connected to protection earth on the frequency converter. Use only isolated laptop as PC connection to the USB connector on the frequency converter.

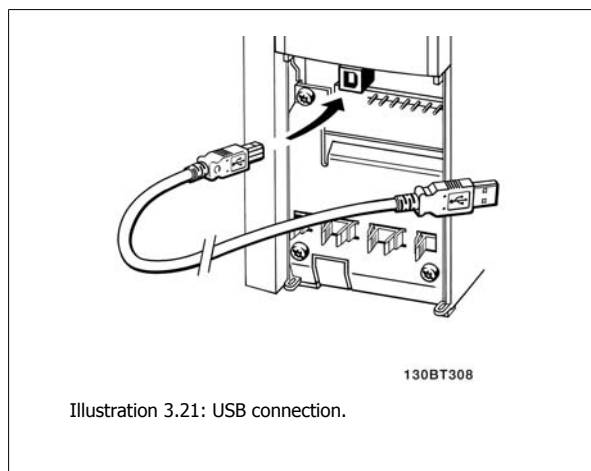

Illustration 3.21: USB connection.

### 3.7.5 The FC 300 PC Software

**Data storage in PC via MCT 10 Set-Up Software:**

1. Connect a PC to the unit via USB com port
2. Open MCT 10 Set-up Software
3. Select in the "network" section the USB port
4. Choose "Copy"
5. Select the "project" section
6. Choose "Paste"
7. Choose "Save as"

All parameters are now stored.

**Data transfer from PC to drive via MCT 10 Set-Up Software:**

1. Connect a PC to the unit via USB com port
2. Open MCT 10 Set-up software
3. Choose "Open"– stored files will be shown
4. Open the appropriate file
5. Choose "Write to drive"

All parameters are now transferred to the drive.

A separate manual for MCT 10 Set-up Software is available.



## 4 How to Programme

### 4.1 The Graphical and Numerical LCP

The easiest programming of the frequency converter is performed by the Graphical LCP ( 102). It is necessary to consult the frequency converter Design Guide, when using the Numeric Local Control Panel (LCP 101).

#### 4.1.1 How to Programme on the Graphical LCP

The following instructions are valid for the graphical LCP (LCP 102):

**The control panel is divided into four functional groups:**

1. Graphical display with Status lines.
2. Menu keys and indicator lights - changing parameters and switching between display functions.
3. Navigation keys and indicator lights (LEDs).
4. Operation keys and indicator lights (LEDs).

All data is displayed in a graphical LCP display, which can show up to five items of operating data while displaying [Status].

**Display lines:**

- a. **Status line:** Status messages displaying icons and graphic.
- b. **Line 1-2:** Operator data lines displaying data defined or chosen by the user. By pressing the [Status] key, up to one extra line can be added.
- c. **Status line:** Status messages displaying text.

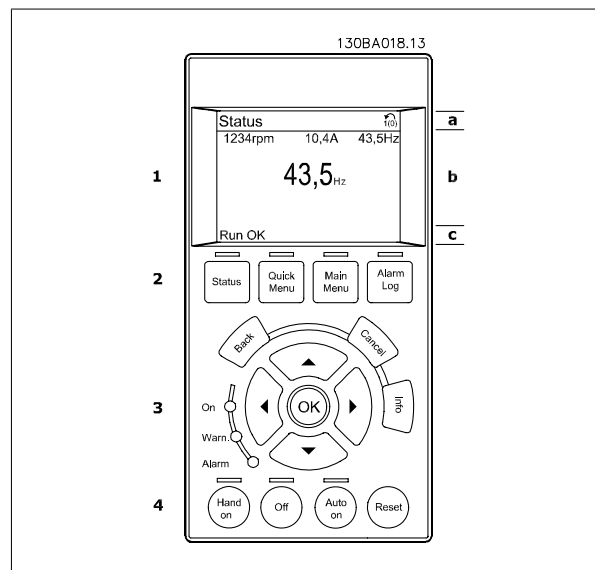

#### 4.1.2 How to Programme on the Numerical Local Control Panel

The following instructions are valid for the numerical LCP (LCP 101):

**The control panel is divided into four functional groups:**

1. Numerical display.
2. Menu keys and indicator lights - changing parameters and switching between display functions.
3. Navigation keys and indicator lights (LEDs).
4. Operation keys and indicator lights (LEDs).

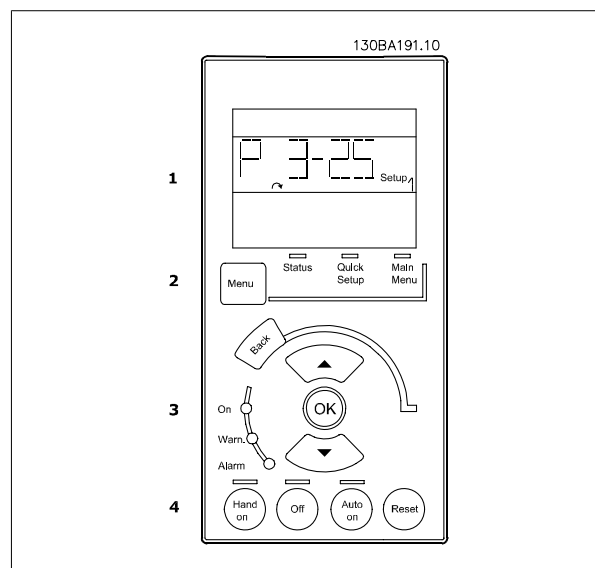

### 4.1.3 Initial Commissioning

The easiest way of carrying out the initial commissioning is by using the Quick Menu button and follow the quick set-up procedure using LCP 102 (read table from left to right). The example applies to open loop applications:

4

Press			
		Q2 Quick Menu	
Par.0-01 <i>Language</i>		Set language	
Par.1-20 <i>Motor Power [kW]</i>		Set Motor nameplate power	
Par. 1-22 <i>Motor Voltage</i>		Set Nameplate voltage	
Par.1-23 <i>Motor Frequency</i>		Set Nameplate frequency	
Par. 1-24 <i>Motor Current</i>		Set Nameplate current	
Par. 1-25 <i>Motor Nominal Speed</i>		Set Nameplate speed in RPM	
Par. 5-12 <i>Terminal 27 Digital Input</i>		If terminal default is <i>Coast inverse</i> it is possible to change this setting to <i>No function</i> . No connection to terminal 27 is then needed for running AMA	
Par. 1-29 <i>Automatic Motor Adaptation (AMA)</i>		Set desired AMA function. Enable complete AMA is recommended	
Par.3-02 <i>Minimum Reference</i>		Set the minimum speed of the motor shaft	
Par.3-03 <i>Maximum Reference</i>		Set the maximum speed of the motor shaft	
Par.3-41 <i>Ramp 1 Ramp up Time</i>		Set the ramping up time with reference to synchronous motor speed, $n_s$	
Par.3-42 <i>Ramp 1 Ramp Down Time</i>		Set the ramping down time with reference to synchronous motor speed, $n_s$	
Par. 3-13 <i>Reference Site</i>		Set the site from where the reference must work	

## 4.2 Quick Setup

0-01 Language		
Option:		Function:
		Defines the language to be used in the display. The frequency converter can be delivered with 4 different language packages. English and German are included in all packages. English cannot be erased or manipulated.
[0] *	English	Part of Language packages 1 - 4
[1]	Deutsch	Part of Language packages 1 - 4
[2]	Francais	Part of Language package 1
[3]	Dansk	Part of Language package 1
[4]	Spanish	Part of Language package 1
[5]	Italiano	Part of Language package 1
	Svenska	Part of Language package 1
[7]	Nederlands	Part of Language package 1
	Chinese	Part of Language package 2
	Suomi	Part of Language package 1
	English US	Part of Language package 4
	Greek	Part of Language package 4
	Bras.port	Part of Language package 4
	Slovenian	Part of Language package 3
	Korean	Part of Language package 2
	Japanese	Part of Language package 2
	Turkish	Part of Language package 4
	Trad.Chinese	Part of Language package 2
	Bulgarian	Part of Language package 3
	Srpski	Part of Language package 3
	Romanian	Part of Language package 3
	Magyar	Part of Language package 3
	Czech	Part of Language package 3
	Polski	Part of Language package 4
	Russian	Part of Language package 3
	Thai	Part of Language package 2
	Bahasa Indonesia	Part of Language package 2

### 1-20 Motor Power [kW]

**Range:**

4.00 kW\* [0.09 - 3000.00 kW]

**Function:**

Enter the nominal motor power in kW according to the motor nameplate data. The default value corresponds to the nominal rated output of the unit.

This parameter cannot be adjusted while the motor is running. This parameter is visible in LCP if par. 0-03 *Regional Settings* is *International* [0].

**NB!**

Four sizes down, one size up from nominal VLT rating.

### 1-22 Motor Voltage

**Range:**

400. V\* [10. - 1000. V]

**Function:**

Enter the nominal motor voltage according to the motor nameplate data. The default value corresponds to the nominal rated output of the unit.

This parameter cannot be adjusted while the motor is running.

### 1-23 Motor Frequency

**Range:**

50. Hz\* [20 - 1000 Hz]

**Function:**

Min - Max motor frequency: 20 - 1000 Hz.

Select the motor frequency value from the motor nameplate data. If a value different from 50 Hz or 60 Hz is selected, it is necessary to adapt the load independent settings in par. 1-50 *Motor Magnetisation at Zero Speed* to par. 1-53 *Model Shift Frequency*. For 87 Hz operation with 230/400 V motors, set the nameplate data for 230 V/50 Hz. Adapt par. 4-13 *Motor Speed High Limit [RPM]* and par.3-03 *Maximum Reference* to the 87 Hz application.

### 1-24 Motor Current

**Range:**

7.20 A\* [0.10 - 10000.00 A]

**Function:**

Enter the nominal motor current value from the motor nameplate data. This data is used for calculating motor torque, motor thermal protection etc.

**NB!**

This parameter cannot be adjusted while the motor is running.

### 1-25 Motor Nominal Speed

**Range:**

1420. RPM\* [100 - 60000 RPM]

**Function:**

Enter the nominal motor speed value from the motor nameplate data. This data is used for calculating automatic motor compensations.

**NB!**

This parameter cannot be adjusted while the motor is running.

**5-12 Terminal 27 Digital Input**

**Option:**

**Function:**

Select the function from the available digital input range.

No operation	[0]
Reset	[1]
Coast inverse	[2]
Coast and reset inverse	[3]
Quick stop inverse	[4]
DC-brake inverse	[5]
Stop inverse	[6]
Start	[8]
Latched start	[9]
Reversing	[10]
Start reversing	[11]
Enable start forward	[12]
Enable start reverse	[13]
Jog	[14]
Preset ref bit 0	[16]
Preset ref bit 1	[17]
Preset ref bit 2	[18]
Freeze reference	[19]
Freeze output	[20]
Speed up	[21]
Speed down	[22]
Set-up select bit 0	[23]
Set-up select bit 1	[24]
Catch up	[28]
Slow down	[29]
Pulse input	[32]
Ramp bit 0	[34]
Ramp bit 1	[35]
Mains failure inverse	[36]
DigiPot Increase	[55]
DigiPot Decrease	[56]
DigiPot Clear	[57]
Reset Counter A	[62]
Reset Counter B	[65]

**1-29 Automatic Motor Adaptation (AMA)**

**Option:**

**Function:**

The AMA function optimizes dynamic motor performance by automatically optimizing the advanced motor parameters (par. 1-30 to par. 1-35) at motor standstill.

Activate the AMA function by pressing [Hand on] after selecting [1] or [2]. See also the section *Automatic Motor Adaptation*. After a normal sequence, the display will read: "Press [OK] to finish AMA". After pressing the [OK] key the frequency converter is ready for operation.

This parameter cannot be adjusted while the motor is running.

[0] *	OFF	
[1]	Enable complete AMA	Performs AMA of the stator resistance $R_s$ , the rotor resistance $R_r$ , the stator leakage reactance $X_{11}$ , the rotor leakage reactance $X_{22}$ and the main reactance $X_h$ .  <b>FC 301:</b> The complete AMA does not include $X_h$ measurement for FC 301. Instead, the $X_h$ value is determined from the motor database. Par. 1-35 may be adjusted to obtain optimal start performance.
[2]	Enable reduced AMA	Performs a reduced AMA of the stator resistance $R_s$ in the system only. Select this option if an LC filter is used between the drive and the motor.

**Note:**

- For the best adaptation of the frequency converter, run AMA on a cold motor.
- AMA cannot be performed while the motor is running.
- AMA cannot be performed on permanent magnet motors.

**NB!**

It is important to set motor par. 1-2\* correctly, since these form part of the AMA algorithm. An AMA must be performed to achieve optimum dynamic motor performance. It may take up to 10 min, depending on the power rating of the motor.

**NB!**

Avoid generating external torque during AMA.

**NB!**

If one of the settings in par. 1-2\* is changed, par. 1-30 to par. 1-39, the advanced motor parameters, will return to default setting.

4

### 3-02 Minimum Reference

**Range:**

0 Referen- [-999999.999 - par. 3-03 Referen-  
ceFeedback-ceFeedbackUnit]  
Unit\*

**Function:**

Enter the Minimum Reference. The Minimum Reference is the lowest value obtainable by summing all references.

Minimum Reference is active only when par. 3-00 *Reference Range* is set to *Min.- Max.* [0].

The Minimum Reference unit matches:

- The choice of configuration in par. 1-00 *Configuration Mode Configuration Mode*: for *Speed closed loop* [1], RPM; for *Torque* [2], Nm.
- The unit selected in par. 3-01 *Reference/Feedback Unit*.

### 3-03 Maximum Reference

**Range:**

1500.000 [par. 3-02 - 999999.999 Referen-  
Reference- ceFeedbackUnit]  
FeedbackU-  
nit\*

**Function:**

Enter the Maximum Reference. The Maximum Reference is the highest value obtainable by summing all references.

**The Maximum Reference unit matches:**

- The choice of configuration in par. 1-00 *Configuration Mode*: for *Speed closed loop* [1], RPM; for *Torque* [2], Nm.
- The unit selected in par. 3-00 *Reference Range*.

### 3-41 Ramp 1 Ramp up Time

**Range:**

3.00 s\* [0.01 - 3600.00 s]

**Function:**

Enter the ramp-up time, i.e. the acceleration time from 0 RPM to the synchronous motor speed  $n_s$ . Choose a ramp-up time such that the output current does not exceed the current limit in par. 4-18 *Current Limit* during ramping. The value 0.00 corresponds to 0.01 sec. in speed mode. See ramp-down time in par.3-42 *Ramp 1 Ramp Down Time*.

$$Par. 3 - 41 = \frac{t_{acc} [s] \times n_s [RPM]}{ref [RPM]}$$

### 3-42 Ramp 1 Ramp Down Time

**Range:**

3.00 s\* [0.01 - 3600.00 s]

**Function:**

Enter the ramp-down time, i.e. the deceleration time from the synchronous motor speed  $n_s$  to 0 RPM. Choose a ramp-down time such that no over-voltage arises in the inverter due to regenerative operation of the motor, and such that the generated current does not exceed the current limit set in par. 4-18 *Current Limit*. The value 0.00 corresponds to 0.01 s in speed mode. See ramp-up time in par.3-41 *Ramp 1 Ramp up Time*.

$$Par. 3 - 42 = \frac{t_{dec} [s] \times n_s [RPM]}{ref [RPM]}$$

### 4.3 Basic setup parameters

#### 0-02 Motor Speed Unit

**Option:**

**Function:**

This parameter cannot be adjusted while the motor is running.  
 The display showing depends on settings in par.0-02 *Motor Speed Unit* and par. 0-03 *Regional Settings*. The default setting of par.0-02 *Motor Speed Unit* and par. 0-03 *Regional Settings* depends on which region of the world the frequency converter is supplied to, but can be re-programmed as required.



**NB!**  
 Changing the *Motor Speed Unit* will reset certain parameters to their initial value. It is recommended to select the motor speed unit first, before modifying other parameters.

[0] RPM Selects display of motor speed variables and parameters (i.e. references, feedbacks and limits) in terms of motor speed (RPM).

[1] \* Hz Selects display of motor speed variables and parameters (i.e. references, feedbacks and limits) in terms of output frequency to the motor (Hz).

#### 0-50 LCP Copy

**Option:**

**Function:**

- [0] \* No copy
- [1] All to LCP Copies all parameters in all set-ups from the frequency converter memory to the LCP memory.
- [2] All from LCP Copies all parameters in all set-ups from the LCP memory to the frequency converter memory.
- [3] Size indep. from LCP Copy only the parameters that are independent of the motor size. The latter selection can be used to programme several frequency converters with the same function without disturbing motor data.
- [4] File from MCO to LCP
- [5] File from LCP to MCO
- [6] Data from DYN to LCP
- [7] Data from LCP to DYN

This parameter cannot be adjusted while the motor is running.

#### 1-03 Torque Characteristics

**Option:**

**Function:**

Select the torque characteristic required.  
 VT and AEO are both energy saving operations.

[0] \* Constant torque Motor shaft output provides constant torque under variable speed control.

[1] Variable torque Motor shaft output provides variable torque under variable speed control. Set the variable torque level in par. 14-40 *VT Level*.

[2] Auto Energy Optim. Automatically optimises energy consumption by minimising magnetisation and frequency via par. 14-41 *AEO Minimum Magnetisation* and par. 14-42 *Minimum AEO Frequency*.

[5] Constant Power

This parameter cannot be adjusted while the motor is running.

#### 1-04 Overload Mode

**Option:**

**Function:**

[0] \* High torque Allows up to 160% over torque.

[1] Normal torque For oversized motor - allows up to 110% over torque.

This parameter cannot be adjusted while the motor is running.

4

**1-90 Motor Thermal Protection**

Option:	Function:
	The frequency converter determines the motor temperature for motor protection in two different ways: <ul style="list-style-type: none"> <li>Via a thermistor sensor connected to one of the analog or digital inputs (par.1-93 <i>Thermistor Source</i>).</li> <li>Via calculation (ETR = Electronic Terminal Relay) of the thermal load, based on the actual load and time. The calculated thermal load is compared with the rated motor current <math>I_{M,N}</math> and the rated motor frequency <math>f_{M,N}</math>. The calculations estimate the need for a lower load at lower speed due to less cooling from the fan incorporated in the motor.</li> </ul>
[0] *	No protection Continuously overloaded motor, when no warning or trip of the frequency converter is required.
[1]	Thermistor warning Activates a warning when the connected thermistor or KTY-sensor in the motor reacts in the event of motor over-temperature.
[2]	Thermistor trip Stops (trips) frequency converter when connected thermistor in motor reacts in the event of motor over-temperature.  The thermistor cut-out value must be > 3 kΩ.  Integrate a thermistor (PTC sensor) in the motor for winding protection.
[3]	ETR warning 1 Please see detailed description below
[4]	ETR trip 1
[5]	ETR warning 2
[6]	ETR trip 2
[7]	ETR warning 3
[8]	ETR trip 3
[9]	ETR warning 4
[10]	ETR trip 4

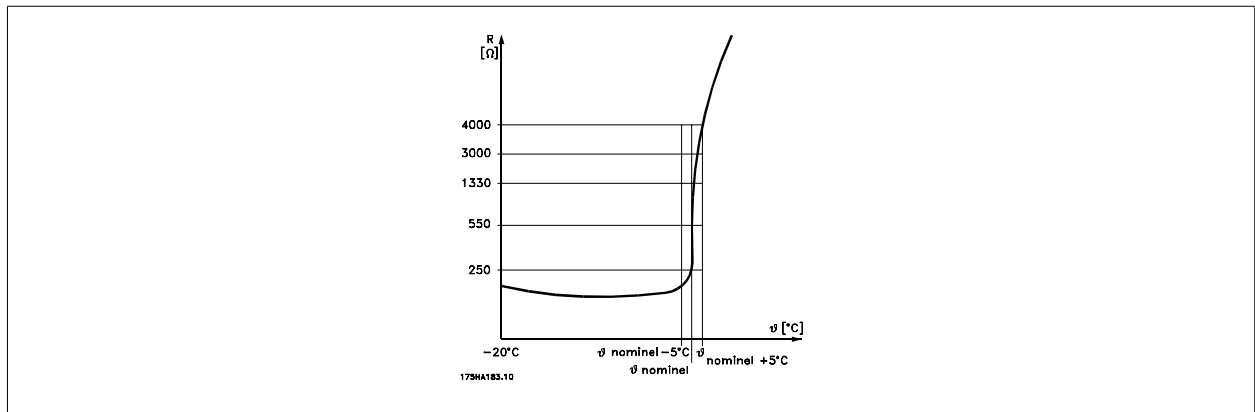

Motor protection can be implemented using a range of techniques: PTC or KTY sensor (see also section *KTY Sensor Connection*) in motor windings; mechanical thermal switch (Klixon type); or Electronic Thermal Relay (ETR).

Using a digital input and 24 V as power supply:

Example: The frequency converter trips when the motor temperature is too high

Parameter set-up:

Set par.1-90 *Motor Thermal Protection* to *Thermistor Trip* [2]

Set par.1-93 *Thermistor Source* to *Digital Input* [6]



4

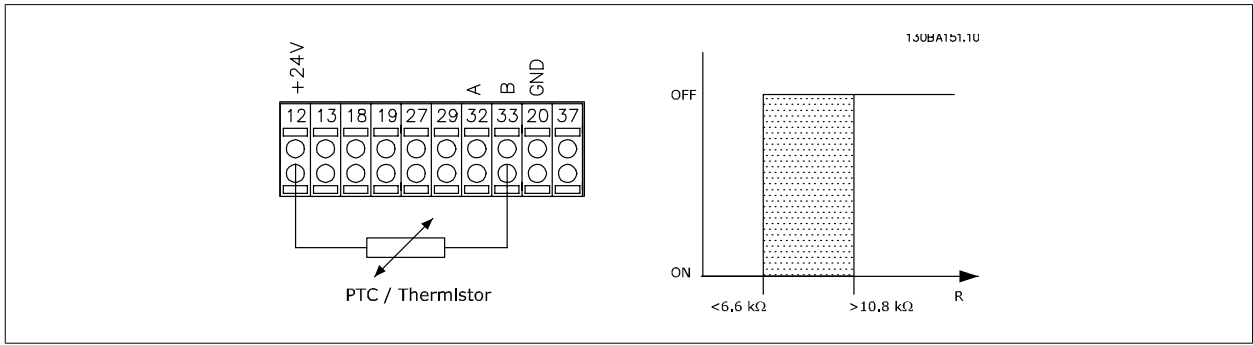

Using a digital input and 10 V as power supply:  
 Example: The frequency converter trips when the motor temperature is too high.  
 Parameter set-up:  
 Set par.1-90 *Motor Thermal Protection* to *Thermistor Trip* [2]  
 Set par.1-93 *Thermistor Source* to *Digital Input* [6]

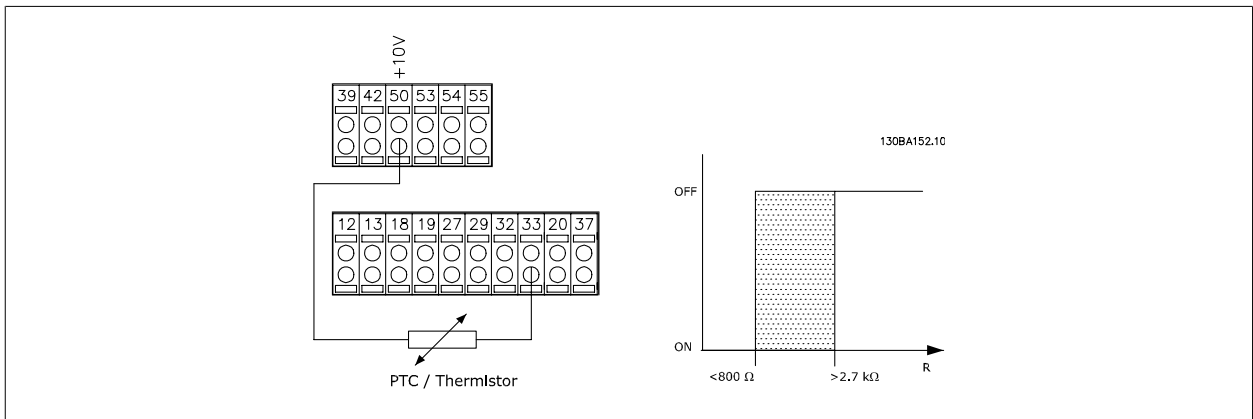

Using an analog input and 10 V as power supply:  
 Example: The frequency converter trips when the motor temperature is too high.  
 Parameter set-up:  
 Set par.1-90 *Motor Thermal Protection* to *Thermistor Trip* [2]  
 Set par.1-93 *Thermistor Source* to *Analog Input 54* [2]

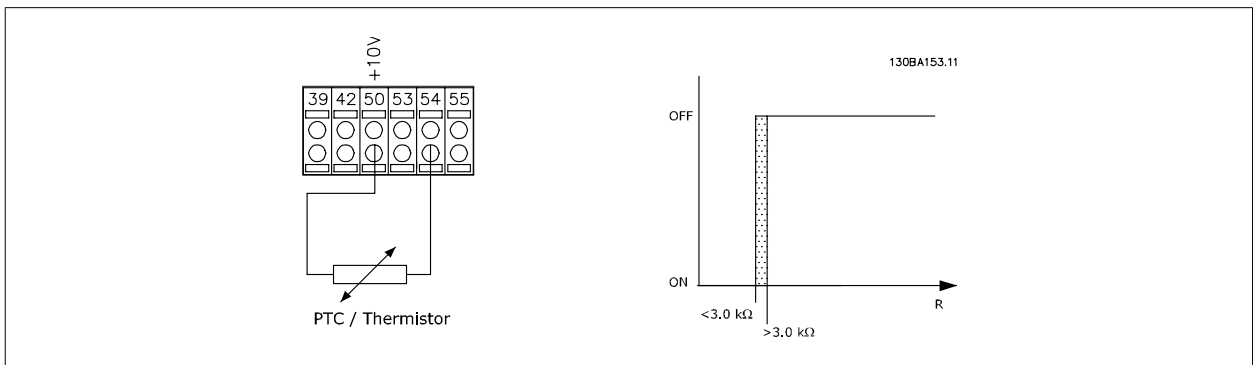

Input	Supply Voltage	Threshold
Digital/analog	Volt	Cut-out Values
Digital	24 V	< 6.6 kΩ - > 10.8 kΩ
Digital	10 V	< 800Ω - > 2.7 kΩ
Analog	10 V	< 3.0 kΩ - > 3.0 kΩ



**NB!**

Check that the chosen supply voltage follows the specification of the used thermistor element.

Select *ETR Warning 1-4*, to activate a warning on the display when the motor is overloaded.

Select *ETR Trip 1-4* to trip the frequency converter when the motor is overloaded.

Programme a warning signal via one of the digital outputs. The signal appears in the event of a warning and if the frequency converter trips (thermal warning).

ETR (Electronic Terminal Relay) functions 1-4 will calculate the load when the set-up where they were selected is active. For example ETR starts calculating when setup 3 is selected. For the North American market: The ETR functions provide class 20 motor overload protection in accordance with NEC.

4

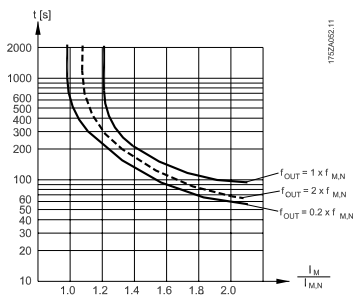

**1-93 Thermistor Source**

Option:	Function:
	Select the input to which the thermistor (PTC sensor) should be connected. An analog input option [1] or [2] cannot be selected if the analog input is already in use as a reference source (selected in par. 3-15 <i>Reference 1 Source</i> , par. 3-16 <i>Reference 2 Source</i> or par. 3-17 <i>Reference 3 Source</i> ). When using MCB112, choice [0] <i>None</i> must always be selected.

- [0] \* None
- [1] Analog input 53
- [2] Analog input 54
- [3] Digital input 18
- [4] Digital input 19
- [5] Digital input 32
- [6] Digital input 33



**NB!**

This parameter cannot be adjusted while the motor is running.



**NB!**

Digital input should be set to [0] *PNP - Active at 24V* in par. 5-00.

**2-10 Brake Function**

Option:	Function:
[0] * Off	No brake resistor is installed.

[1] Resistor brake  
 A brake resistor is incorporated in the system, for dissipation of surplus brake energy as heat. Connecting a brake resistor allows a higher DC link voltage during braking (generating operation). The Resistor brake function is only active in frequency converters with an integral dynamic brake.

[2] AC brake  
 Is selected to improve braking without using a brake resistor. This parameter controls an overmagnetization of the motor when running with a generatoric load. This function can improve the OVC-function. Increasing the electrical losses in the motor allows the OVC function to increase the braking torque without exceeding the over voltage limit. Please note that AC brake is not as effective as dynamic braking with resistor.  
 AC brake is for VVC<sup>+</sup> and flux mode in both open and closed loop.

**2-11 Brake Resistor (ohm)**

**Range:** 50. Ohm\* [5. - 32000. Ohm]  
**Function:** Set the brake resistor value in Ohms. This value is used for monitoring the power to the brake resistor in par. 2-13 *Brake Power Monitoring*. This parameter is only active in frequency converters with an integral dynamic brake.  
 Use this parameter for values without decimals. For a selection with two decimals, use par. 30-81 *Brake Resistor (ohm)*.

**2-12 Brake Power Limit (kW)**

**Range:** 5.000 kW\* [0.001 - 500.000 kW]  
**Function:** Set the monitoring limit of the brake power transmitted to the resistor.  
 The monitoring limit is a product of the maximum duty cycle (120 sec.) and the maximum power of the brake resistor at that duty cycle. See the formula below.

For 200 - 240 V units:	$P_{resistor} = \frac{390^2 \times dutytime}{R \times 120}$
For 380 - 480 V units	$P_{resistor} = \frac{778^2 \times dutytime}{R \times 120}$
For 380 - 500 V units	$P_{resistor} = \frac{810^2 \times dutytime}{R \times 120}$
For 575 - 600 V units	$P_{resistor} = \frac{943^2 \times dutytime}{R \times 120}$

This parameter is only active in frequency converters with an integral dynamic brake.

**2-13 Brake Power Monitoring**

**Option:**  
**Function:** This parameter is only active in frequency converters with an integral dynamic brake. This parameter enables monitoring of the power to the brake resistor. The power is calculated on the basis of the resistance (par.2-11 *Brake Resistor (ohm)*), the DC link voltage, and the resistor duty time.

[0] \* Off No brake power monitoring required.

[1] Warning Activates a warning on the display when the power transmitted over 120 s exceeds 100% of the monitoring limit (par.2-12 *Brake Power Limit (kW)*). The warning disappears when the transmitted power falls below 80% of the monitoring limit.

[2] Trip Trips frequency converter and displays an alarm when the calculated power exceeds 100% of the monitoring limit.

[3] Warning and trip Activates both of the above, including warning, trip and alarm.

If power monitoring is set to *Off*[0] or *Warning*[1], the brake function remains active, even if the monitoring limit is exceeded. This may lead to thermal overload of the resistor. It is also possible to generate a warning via a relay/digital outputs. The measuring accuracy of the power monitoring depends on the accuracy of the resistance of the resistor (better than ± 20%).

## 2-15 Brake Check

### Option:

### Function:

Select type of test and monitoring function to check the connection to the brake resistor, or whether a brake resistor is present, and then display a warning or an alarm in the event of a fault.



#### NB!

The brake resistor disconnection function is tested during power-up. However the brake IGBT test is performed when there is no braking. A warning or trip disconnects the brake function.

The testing sequence is as follows:

1. The DC link ripple amplitude is measured for 300 ms without braking.
2. The DC link ripple amplitude is measured for 300 ms with the brake turned on.
3. If the DC link ripple amplitude while braking is lower than the DC link ripple amplitude before braking + 1 %: *Brake check has failed by returning a warning or alarm.*
4. If the DC link ripple amplitude while braking is higher than the DC link ripple amplitude before braking + 1 %: *Brake check is OK.*

[0] *	Off	Monitors brake resistor and brake IGBT for a short-circuit during operation. If a short-circuit occurs, warning 25 appears.
[1]	Warning	Monitors brake resistor and brake IGBT for a short-circuit, and runs a test for brake resistor disconnection during power-up.
[2]	Trip	Monitors for a short-circuit or disconnection of the brake resistor, or a short-circuit of the brake IGBT. If a fault occurs, the frequency converter cuts out while displaying an alarm (trip locked).
[3]	Stop and trip	Monitors for a short-circuit or disconnection of the brake resistor, or a short-circuit of the brake IGBT. If a fault occurs, the frequency converter ramps down to coast and then trips. A trip lock alarm is displayed (e.g. warning 25, 27 or 28).
[4]	AC brake	Monitors for a short-circuit or disconnection of the brake resistor, or a short-circuit of the brake IGBT. If a fault occurs, the frequency converter performs a controlled ramp down. This option is available for FC 302 only.
[5]	Trip Lock	



#### NB!

Remove a warning arising in connection with *Off*[0] or *Warning* [1] by cycling the mains supply. The fault must be corrected first. For *Off*[0] or *Warning* [1], the frequency converter keeps running even if a fault is located.

This parameter is only active in frequency converters with an integral dynamic brake.

### 4.3.1 2-2\* Mechanical Brake

Parameters for controlling operation of an electro-magnetic (mechanical) brake, typically required in hoisting applications.

To control a mechanical brake, a relay output (relay 01 or relay 02) or a programmed digital output (terminal 27 or 29) is required. Normally this output must be closed during periods when the frequency converter is unable to 'hold' the motor, e.g. due to an excessive load. Select *Mechanical Brake Control* [32] for applications with an electro-magnetic brake in par.5-40 *Function Relay*, par. 5-30 *Terminal 27 Digital Output*, or par. 5-31 *Terminal 29 Digital Output*. When selecting *Mechanical brake control* [32], the mechanical brake is closed from start up until the output current is above the level selected in par.2-20 *Release Brake Current*. During stop, the mechanical brake activates when the speed falls below the level specified in par.2-21 *Activate Brake Speed [RPM]*. If the frequency converter enters an alarm condition or an over-current or over-voltage situation, the mechanical brake immediately cuts in. This is also the case during safe stop.



**NB!**

Protection mode and trip delay features (par. 14-25 *Trip Delay at Torque Limit* and par. 14-26 *Trip Delay at Inverter Fault*) may delay the activation of the mechanical brake in an alarm condition. These features must be disabled in hoisting applications.

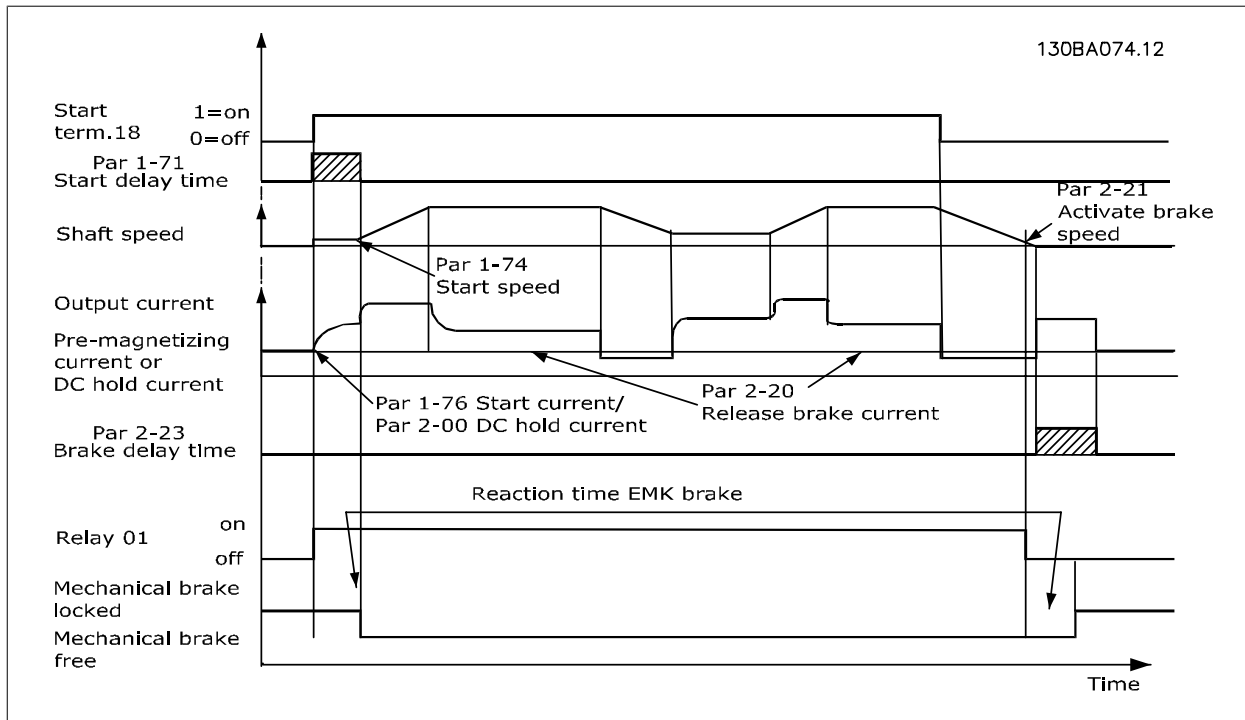

**2-20 Release Brake Current**

**Range:**

par. 16-37 [0.00 - par. 16-37 A] A\*

**Function:**

Set the motor current for release of the mechanical brake, when a start condition is present. The upper limit is specified in par. 16-37 *Inv. Max. Current*.

**2-21 Activate Brake Speed [RPM]**

**Range:**

0 RPM\* [0 - 30000 RPM]

**Function:**

Set the motor speed for activation of the mechanical brake, when a stop condition is present. The upper speed limit is specified in par. 4-53 *Warning Speed High*.

**2-22 Activate Brake Speed [Hz]**

**Range:**

0 Hz\* [0.0 - 5000.0 Hz]

**Function:**

Set the motor frequency for activation of the mechanical brake, when a stop condition is present.

**2-23 Activate Brake Delay**

**Range:**

0.0 s\* [0.0 - 5.0 s]

**Function:**

Enter the brake delay time of the coast after ramp-down time. The shaft is held at zero speed with full holding torque. Ensure that the mechanical brake has locked the load before the motor enters coast mode. See *Mechanical Brake Control* section in the Design Guide.

**2-24 Stop Delay**

**Range:**

0.0 s\* [0.0 - 5.0 s]

**Function:**

Set the time interval from the moment when the motor is stopped until the brake closes. This parameter is a part of the stopping function.

4

**2-25 Brake Release Time**

**Range:** 0.20 s\* [0.00 - 5.00 s] **Function:** This value defines the time it takes for the mechanical brake to open. This parameter must act as a time-out when brake feedback is activated.

**2-26 Torque Ref**

**Range:** 0.00 %\* [0 - 0 %] **Function:** The value defines the torque applied against the closed mechanical brake, before release

**2-27 Torque Ramp Time**

**Range:** 0.2 s\* [0.0 - 5.0 s] **Function:** The value defines the duration of the torque ramp in clockwise direction.

**2-28 Gain Boost Factor**

**Range:** 1.00 N/A\* [1.00 - 4.00 N/A] **Function:** Only active in flux closed loop. The function ensures a smooth transition from torque control mode to speed control mode when the motor takes over the load from the brake.

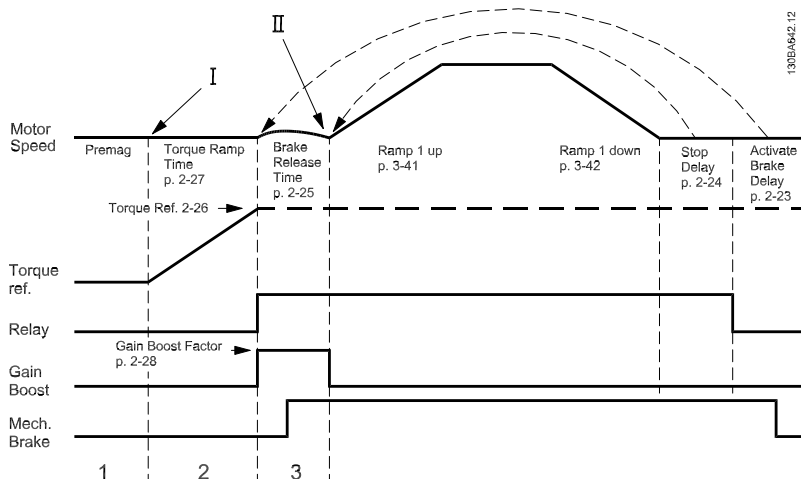

Illustration 4.1: Brake release sequence for hoist mechanical brake control

- I) *Activate brake delay*: The frequency converter starts again from the *mechanical brake engaged* position.
- II) *Stop delay*: When the time between successive starts is shorter than the setting in par.2-24 *Stop Delay*, the frequency converter starts without applying the mechanical brake (e.g. reversing).

**3-10 Preset Reference**

Array [8]  
Range: 0-7

**Range:** 0.00 %\* [-100.00 - 100.00 %] **Function:** Enter up to eight different preset references (0-7) in this parameter, using array programming. The preset reference is stated as a percentage of the value Ref<sub>MAX</sub> (par.3-03 *Maximum Reference*) If a Ref<sub>MIN</sub> different from 0 (par.3-02 *Minimum Reference*) is programmed, the preset reference is calculated as a percentage of the full reference range, i.e. on the basis of the difference between Ref<sub>MAX</sub> and Ref<sub>MIN</sub>. Afterwards, the value is added to Ref<sub>MIN</sub>. When using preset references, select Preset ref. bit 0 / 1 / 2 [16], [17] or [18] for the corresponding digital inputs in parameter group 5-1\*.

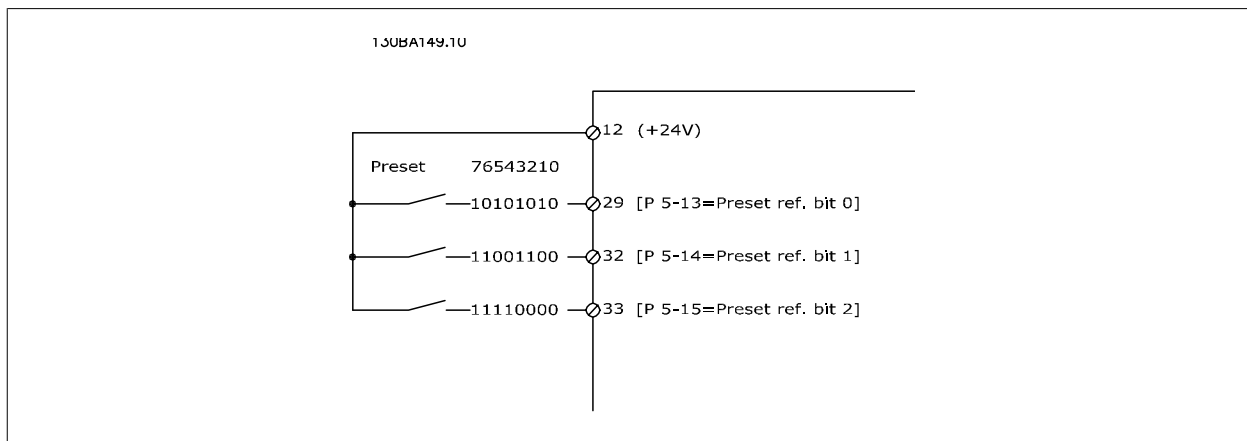

Preset ref. bit	2	1	0
Preset ref. 0	0	0	0
Preset ref. 1	0	0	1
Preset ref. 2	0	1	0
Preset ref. 3	0	1	1
Preset ref. 4	1	0	0
Preset ref. 5	1	0	1
Preset ref. 6	1	1	0
Preset ref. 7	1	1	1

### 3-11 Jog Speed [Hz]

**Range:**

0 Hz\* [0.0 - par. 4-14 Hz]

**Function:**

The jog speed is a fixed output speed at which the frequency converter is running when the jog function is activated.  
See also par. 3-80 *Jog Ramp Time*.

### 3-15 Reference Resource 1

**Option:**

**Function:**

Select the reference input to be used for the first reference signal. par.3-15 *Reference Resource 1*, par.3-16 *Reference Resource 2* and par.3-17 *Reference Resource 3* define up to three different reference signals. The sum of these reference signals defines the actual reference.

- [0] No function
- [1] \* Analog input 53
- [2] Analog input 54
- [7] Frequency input 29
- [8] Frequency input 33
- [11] Local bus reference
- [20] Digital pot.meter
- [21] Analog input X30-11 (General Purpose I/O Option Module)
- [22] Analog input X30-12 (General Purpose I/O Option Module)

### 3-16 Reference Resource 2

**Option:**

**Function:**

Select the reference input to be used for the second reference signal. par.3-15 *Reference Resource 1*, par.3-16 *Reference Resource 2* and par.3-17 *Reference Resource 3* define up to three different reference signals. The sum of these reference signals defines the actual reference.

- [0] No function
- [1] Analog input 53

4

- [2] Analog input 54
- [7] Frequency input 29
- [8] Frequency input 33
- [11] Local bus reference
- [20] \* Digital pot.meter
- [21] Analog input X30-11
- [22] Analog input X30-12

**3-17 Reference Resource 3**

**Option:** **Function:**  
 Select the reference input to be used for the third reference signal. par.3-15 *Reference Resource 1*, par.3-16 *Reference Resource 2* and par.3-17 *Reference Resource 3* define up to three different reference signals. The sum of these reference signals defines the actual reference.

- [0] No function
- [1] Analog input 53
- [2] Analog input 54
- [7] Frequency input 29
- [8] Frequency input 33
- [11] \* Local bus reference
- [20] Digital pot.meter
- [21] Analog input X30-11
- [22] Analog input X30-12

**5-00 Digital I/O Mode**

**Option:** **Function:**  
 Digital inputs and programmed digital outputs are pre-programmable for operation either in PNP or NPN systems.

- [0] \* PNP Action on positive directional pulses (↑). PNP systems are pulled down to GND.
- [1] NPN Action on negative directional pulses (↓). NPN systems are pulled up to + 24 V, internally in the frequency converter.



**NB!**  
 Once this parameter has been changed, it must be activated by performing a power cycle.

This parameter cannot be adjusted while the motor is running.

**5-01 Terminal 27 Mode**

**Option:** **Function:**

- [0] \* Input Defines terminal 27 as a digital input.
- [1] Output Defines terminal 27 as a digital output.

Please note that this parameter cannot be adjusted while the motor is running.

**5-02 Terminal 29 Mode**

**Option:** **Function:**

- [0] \* Input Defines terminal 29 as a digital input.
- [1] Output Defines terminal 29 as a digital output.

This parameter is available for FC 302 only.  
 This parameter cannot be adjusted while the motor is running.



### 4.3.2 5-1\* Digital Inputs

Parameters for configuring the input functions for the input terminals.

The digital inputs are used for selecting various functions in the frequency converter. All digital inputs can be set to the following functions:

Digital input function	Select	Terminal
No operation	[0]	All *term 32, 33
Reset	[1]	All
Coast inverse	[2]	All *term 27
Coast and reset inverse	[3]	All
Quick stop inverse	[4]	All
DC-brake inverse	[5]	All
Stop inverse	[6]	All
Start	[8]	All *term 18
Latched start	[9]	All
Reversing	[10]	All *term 19
Start reversing	[11]	All
Enable start forward	[12]	All
Enable start reverse	[13]	All
Jog	[14]	All *term 29
Preset reference on	[15]	All
Preset ref bit 0	[16]	All
Preset ref bit 1	[17]	All
Preset ref bit 2	[18]	All
Freeze reference	[19]	All
Freeze output	[20]	All
Speed up	[21]	All
Speed down	[22]	All
Set-up select bit 0	[23]	All
Set-up select bit 1	[24]	All
Precise stop inverse	[26]	18, 19
Precises start, stop	[27]	18, 19
Catch up	[28]	All
Slow down	[29]	All
Counter input	[30]	29, 33
Pulse input	[32]	29, 33
Ramp bit 0	[34]	All
Ramp bit 1	[35]	All
Mains failure inverse	[36]	All
Latched precise start	[40]	18, 19
Latched precise stop inverse	[41]	18, 19
DigiPot Increase	[55]	All
DigiPot Decrease	[56]	All
DigiPot Clear	[57]	All
Counter A (up)	[60]	29, 33
Counter A (down)	[61]	29, 33
Reset Counter A	[62]	All
Counter B (up)	[63]	29, 33
Counter B (down)	[64]	29, 33
Reset Counter B	[65]	All
Mech. Brake Feedb.	[70]	All
Mech. Brake Feedb. Inv.	[71]	All
PID enable	[74]	All
MCO Specific	[75]	All
PTC Card 1	[80]	All

FC 300 standard terminals are 18, 19, 27, 29, 32 and 33. MCB 101 terminals are X30/2, X30/3 and X30/4.

Terminal 29 functions as an output only in FC 302.

Functions dedicated to only one digital input are stated in the associated parameter.

All digital inputs can be programmed to these functions:

[0]	No operation	No reaction to signals transmitted to the terminal.
[1]	Reset	Resets frequency converter after a TRIP/ALARM. Not all alarms can be reset.
[2]	Coast inverse	(Default Digital input 27): Coasting stop, inverted input (NC). The frequency converter leaves the motor in free mode. Logic '0' => coasting stop.
[3]	Coast and reset inverse	Reset and coasting stop Inverted input (NC). Leaves motor in free mode and resets frequency converter. Logic '0' => coasting stop and reset.

4

[4]	Quick stop inverse	Inverted input (NC). Generates a stop in accordance with quick-stop ramp time set in par. 3-81 <i>Quick Stop Ramp Time</i> . When motor stops, the shaft is in free mode. Logic '0' => Quick-stop.
[5]	DC-brake inverse	Inverted input for DC braking (NC). Stops motor by energizing it with a DC current for a certain time period. See par. 2-01 <i>DC Brake Current</i> to par. 2-03 <i>DC Brake Cut In Speed [RPM]</i> . The function is only active when the value in par. 2-02 <i>DC Braking Time</i> is different from 0. Logic '0' => DC braking.
[6]	Stop inverse	Stop Inverted function. Generates a stop function when the selected terminal goes from logical level '1' to '0'. The stop is performed according to the selected ramp time (par.3-42 <i>Ramp 1 Ramp Down Time</i> , par. 3-52 <i>Ramp 2 Ramp down Time</i> , par. 3-62 <i>Ramp 3 Ramp down Time</i> , par. 3-72 <i>Ramp 4 Ramp Down Time</i> ).
<div style="display: flex; align-items: center;"> <div> <p><b>NB!</b></p> <p>When the frequency converter is at the torque limit and has received a stop command, it may not stop by itself. To ensure that the frequency converter stops, configure a digital output to <i>Torque limit &amp; stop</i> [27] and connect this digital output to a digital input that is configured as coast.</p> </div> </div>		
[8]	Start	(Default Digital input 18): Select start for a start/stop command. Logic '1' = start, logic '0' = stop.
[9]	Latched start	The motor starts, if a pulse is applied for min. 2 ms. The motor stops when Stop inverse is activated.
[10]	Reversing	(Default Digital input 19). Change the direction of motor shaft rotation. Select Logic '1' to reverse. The reversing signal only changes the direction of rotation. It does not activate the start function. Select both directions in par. 4-10 <i>Motor Speed Direction</i> . The function is not active in process closed loop.
[11]	Start reversing	Used for start/stop and for reversing on the same wire. Signals on start are not allowed at the same time.
[12]	Enable start forward	Disengages the counterclockwise movement and allows for the clockwise direction.
[13]	Enable start reverse	Disengages the clockwise movement and allows for the counterclockwise direction.
[14]	Jog	(Default Digital input 29): Use to activate jog speed. See par.3-11 <i>Jog Speed [Hz]</i> .
[15]	Preset reference on	Shifts between external reference and preset reference. It is assumed that <i>External/preset</i> [1] has been selected in par. 3-04 <i>Reference Function</i> . Logic '0' = external reference active; logic '1' = one of the eight preset references is active.
[16]	Preset ref bit 0	Preset ref. bit 0,1, and 2 enables a choice between one of the eight preset references according to the table below.
[17]	Preset ref bit 1	Same as Preset ref bit 0 [16].
[18]	Preset ref bit 2	Same as Preset ref bit 0 [16].

Preset ref. bit	2	1	0
Preset ref. 0	0	0	0
Preset ref. 1	0	0	1
Preset ref. 2	0	1	0
Preset ref. 3	0	1	1
Preset ref. 4	1	0	0
Preset ref. 5	1	0	1
Preset ref. 6	1	1	0
Preset ref. 7	1	1	1

[19]	Freeze ref	Freezes the actual reference, which is now the point of enable/condition for Speed up and Speed down to be used. If Speed up/down is used, the speed change always follows ramp 2 (par. 3-51 <i>Ramp 2 Ramp up Time</i> and par. 3-52 <i>Ramp 2 Ramp down Time</i> ) in the range 0 - par. 3-03 <i>Maximum Reference</i> .
[20]	Freeze output	Freezes the actual motor frequency (Hz), which is now the point of enable/condition for Speed up and Speed down to be used. If Speed up/down is used, the speed change always follows ramp 2 (par. 3-51 <i>Ramp 2 Ramp up Time</i> and par. 3-52 <i>Ramp 2 Ramp down Time</i> ) in the range 0 - par. 1-23 <i>Motor Frequency</i> .

**NB!**  
 When Freeze output is active, the frequency converter cannot be stopped via a low 'start [8]' signal. Stop the frequency converter via a terminal programmed for Coasting inverse [2] or Coast and reset, inverse.

[21] Speed up  
 Select Speed up and Speed down if digital control of the up/down speed is desired (motor potentiometer). Activate this function by selecting either Freeze reference or Freeze output. When Speed up/ down is activated for less than 400 msec. the resulting reference will be increased/ decreased by 0.1 %. If Speed up/ down is activated for more than 400 msec. the resulting reference will follow the setting in ramping up/ down parameter 3-x1/ 3-x2.

	Shut down	Catch up
Unchanged speed	0	0
Reduced by %-value	1	0
Increased by %-value	0	1
Reduced by %-value	1	1

[22] Speed down  
 Same as Speed up [21].

[23] Set-up select bit 0  
 Select Set-up select bit 0 or Select Set-up select bit 1 to select one of the four set-ups. Set par. 0-10 *Active Set-up* to Multi Set-up.

[24] Set-up select bit 1  
 (Default Digital input 32): Same as Set-up select bit 0 [23].

[26] Precise stop inv.  
 Prolongs stop signal to give a precise stop independent of speed.  
 Sends an inverted stop signal when the precise stop function is activated in par. 1-83 *Precise Stop Function*.  
 Precise stop inverse function is available for terminals 18 or 19.

[27] Precise start, stop  
 Use when Precise ramp stop [0] is selected in par 1-83.

[28] Catch up  
 Increases reference value by percentage (relative) set in par. 3-12 *Catch up/slow Down Value*.

[29] Slow down  
 Reduces reference value by percentage (relative) set in par. 3-12 *Catch up/slow Down Value*.

[30] Counter input  
 Precise stop function in par. 1-83 *Precise Stop Function* acts as Counter stop or speed compensated counter stop with or without reset. The counter value must be set in par. 1-84 *Precise Stop Counter Value*.

[32] Pulse input  
 Use pulse sequence as either reference or feedback. Scaling is done in par. group 5-5\*.

[34] Ramp bit 0  
 Enables a choice between one of the 4 ramps available, according to the table below.

[35] Ramp bit 1  
 Same as Ramp bit 0.

Preset ramp bit	1	0
Ramp 1	0	0
Ramp 2	0	1
Ramp 3	1	0
Ramp 4	1	1

[36] Mains failure inverse  
 Activates par. 14-10 *Mains Failure*. Mains failure inverse is active in the Logic .0. situation.

[41]	Latched Precise Stop inverse	Sends a latched stop signal when the precise stop function is activated in par. 1-83 <i>Precise Stop Function</i> . The Latched Precise stop inverse function is available for terminals 18 or 19.
[55]	DigiPot Increase	INCREASE signal to the Digital Potentiometer function described in par. group 3-9*
[56]	DigiPot Decrease	DECREASE signal to the Digital Potentiometer function described in par. group 3-9*
[57]	DigiPot Clear	Clears the Digital Potentiometer reference described in par. group 3-9*
[60]	Counter A	(Terminal 29 or 33 only) Input for increment counting in the SLC counter.
[61]	Counter A	(Terminal 29 or 33 only) Input for decrement counting in the SLC counter.
[62]	Reset Counter A	Input for reset of counter A.
[63]	Counter B	(Terminal 29 or 33 only) Input for increment counting in the SLC counter.
[64]	Counter B	(Terminal 29 or 33 only) Input for decrement counting in the SLC counter.
[65]	Reset Counter B	Input for reset of counter B.
[70]	Mech. Brake Feedback	Brake feedback for hoisting applications
[71]	Mech. Brake Feedback inv.	Inverted brake feedback for hoisting applications
[74]	PID enable	
[75]	MCO Specific	
[80]	PTC Card 1	All Digital Inputs can be set to PTC Card 1 [80]. However, only one Digital Input must be set to this choice.

### 4.3.3 5-3\* Digital Outputs

Parameters for configuring the output functions for the output terminals. The 2 solid-state digital outputs are common for terminals 27 and 29. Set the I/O function for terminal 27 in par.5-01 *Terminal 27 Mode*, and set the I/O function for terminal 29 in par.5-02 *Terminal 29 Mode*. These parameters cannot be adjusted while the motor is running.

[0]	No operation	<i>Default for all digital outputs and relay outputs</i>
[1]	Control ready	The control board receives supply voltage.
[2]	Drive ready	The frequency converter is ready for operation and applies a supply signal on the control board.
[3]	Drive ready / remote control	The frequency converter is ready for operation and is in Auto On mode.
[4]	Enable / no warning	Ready for operation. No start or stop command is been given (start/disable). There are no warnings.
[5]	VLT running	Motor is running.
[6]	Running / no warning	Output speed is higher than the speed set in par. 1-81 <i>Min Speed for Function at Stop [RPM]</i> . The motor is running and there are no warnings.
[7]	Run in range / no warning	Motor is running within the programmed current and speed ranges set in par. 4-50 <i>Warning Current Low</i> to par. 4-53 <i>Warning Speed High</i> . There are no warnings.
[8]	Run on reference / no warning	Motor runs at reference speed.
[9]	Alarm	An alarm activates the output. There are no warnings.
[10]	Alarm or warning	An alarm or a warning activates the output.
[11]	At torque limit	The torque limit set in par. 4-16 <i>Torque Limit Motor Mode</i> or par. 1-17 has been exceeded.
[12]	Out of current range	The motor current is outside the range set in par. 4-18 <i>Current Limit</i> .
[13]	Below current, low	Motor current is lower than set in par. 4-50 <i>Warning Current Low</i> .
[14]	Above current, high	Motor current is higher than set in par. 4-51 <i>Warning Current High</i> .
[15]	Out of range	Output frequency is outside the frequency range set in par. 4-50 <i>Warning Current Low</i> and par. 4-51 <i>Warning Current High</i> .
[16]	Below speed, low	Output speed is lower than the setting in par. 4-52 <i>Warning Speed Low</i> .
[17]	Above speed, high	Output speed is higher than the setting in par. 4-53 <i>Warning Speed High</i> .
[18]	Out of feedback range	Feedback is outside the range set in par. 4-56 <i>Warning Feedback Low</i> and par. 4-57 <i>Warning Feedback High</i> .
[19]	Below feedback low	Feedback is below the limit set in par. 4-56 <i>Warning Feedback Low</i> .

[20]	Above feedback high	Feedback is above the limit set in par. 4-57 <i>Warning Feedback High</i> .
[21]	Thermal warning	The thermal warning turns on when the temperature exceeds the limit in the motor, the frequency converter, the brake resistor, or the thermistor.
[22]	Ready, no thermal warning	Frequency converter is ready for operation and there is no over-temperature warning.
[23]	Remote, ready, no thermal warning	Frequency converter is ready for operation and is in Auto On mode. There is no over-temperature warning.
[24]	Ready, no over-/ under voltage	Frequency converter is ready for operation and the mains voltage is within the specified voltage range (see <i>General Specifications</i> section).
[25]	Reverse	<i>Reversing. Logic '1'</i> when CW rotation of the motor. Logic '0' when CCW rotation of the motor. If the motor is not rotating the output will follow the reference.
[26]	Bus OK	Active communication (no time-out) via the serial communication port.
[27]	Torque limit and stop	Use in performing a coasting stop and in torque limit condition. If the frequency converter has received a stop signal and is at the torque limit, the signal is Logic '0'.
[28]	Brake, no brake warning	Brake is active and there are no warnings.
[29]	Brake ready, no fault	Brake is ready for operation and there are no faults.
[30]	Brake fault (IGBT)	Output is Logic '1' when the brake IGBT is short-circuited. Use this function to protect the frequency converter if there is a fault on the brake modules. Use the output/relay to cut out the main voltage from the frequency converter.
[31]	Relay 123	Relay is activated when Control Word [0] is selected in parameter group 8-**.
[32]	Mechanical brake control	Enables control of an external mechanical brake, see description in the section <i>Control of Mechanical Brake</i> , and par. group 2-2*
[33]	Safe stop activated (FC 302 only)	Indicates that the safe stop on terminal 37 has been activated.
[40]	Out of ref range	
[41]	Below reference low	
[42]	Above reference high	
[45]	Bus Ctrl	Controls output via bus. The state of the output is set in par. 5-90 <i>Digital &amp; Relay Bus Control</i> . The output state is retained in the event of bus time-out.
[46]	Bus Ctrl On at timeout	Controls output via bus. The state of the output is set in par. 5-90 <i>Digital &amp; Relay Bus Control</i> . In the event of bus time-out the output state is set high (On).
[47]	Bus Ctrl Off at timeout	Controls output via bus. The state of the output is set in par. 5-90 <i>Digital &amp; Relay Bus Control</i> . In the event of bus time-out the output state is set low (Off).
[51]	MCO controlled	
[55]	Pulse output	
[60]	Comparator 0	See par. group 13-1*. If Comparator 0 is evaluated as TRUE, the output will go high. Otherwise, it will be low.
[61]	Comparator 1	See par. group 13-1*. If Comparator 1 is evaluated as TRUE, the output will go high. Otherwise, it will be low.
[62]	Comparator 2	See par. group 13-1*. If Comparator 2 is evaluated as TRUE, the output will go high. Otherwise, it will be low.
[63]	Comparator 3	See par. group 13-1*. If Comparator 3 is evaluated as TRUE, the output will go high. Otherwise, it will be low.
[64]	Comparator 4	See par. group 13-1*. If Comparator 4 is evaluated as TRUE, the output will go high. Otherwise, it will be low.
[65]	Comparator 5	See par. group 13-1*. If Comparator 5 is evaluated as TRUE, the output will go high. Otherwise, it will be low.
[70]	Logic Rule 0	See par. group 13-4*. If Logic Rule 0 is evaluated as TRUE, the output will go high. Otherwise, it will be low.
[71]	Logic Rule 1	See par. group 13-4*. If Logic Rule 1 is evaluated as TRUE, the output will go high. Otherwise, it will be low.
[72]	Logic Rule 2	See par. group 13-4*. If Logic Rule 2 is evaluated as TRUE, the output will go high. Otherwise, it will be low.

[73]	Logic Rule 3	See par. group 13-4*. If Logic Rule 3 is evaluated as TRUE, the output will go high. Otherwise, it will be low.
[74]	Logic Rule 4	See par. group 13-4*. If Logic Rule 4 is evaluated as TRUE, the output will go high. Otherwise, it will be low.
[75]	Logic Rule 5	See par. group 13-4*. If Logic Rule 5 is evaluated as TRUE, the output will go high. Otherwise, it will be low.
[80]	SL Digital Output A	See par. 13-52 <i>SL Controller Action</i> . The output will go high whenever the Smart Logic Action [38] <i>Set dig. out. A high</i> is executed. The output will go low whenever the Smart Logic Action [32] <i>Set dig. out. A low</i> is executed.
[81]	SL Digital Output B	See par. 13-52 <i>SL Controller Action</i> . The input will go high whenever the Smart Logic Action [39] <i>Set dig. out. A high</i> is executed. The input will go low whenever the Smart Logic Action [33] <i>Set dig. out. A low</i> is executed.
[82]	SL Digital Output C	See par. 13-52 <i>SL Controller Action</i> . The input will go high whenever the Smart Logic Action [40] <i>Set dig. out. A high</i> is executed. The input will go low whenever the Smart Logic Action [34] <i>Set dig. out. A low</i> is executed.
[83]	SL Digital Output D	See par. 13-52 <i>SL Controller Action</i> . The input will go high whenever the Smart Logic Action [41] <i>Set dig. out. A high</i> is executed. The input will go low whenever the Smart Logic Action [35] <i>Set dig. out. A low</i> is executed.
[84]	SL Digital Output E	See par. 13-52 <i>SL Controller Action</i> . The input will go high whenever the Smart Logic Action [42] <i>Set dig. out. A high</i> is executed. The input will go low whenever the Smart Logic Action [36] <i>Set dig. out. A low</i> is executed.
[85]	SL Digital Output F	See par. 13-52 <i>SL Controller Action</i> . The input will go high whenever the Smart Logic Action [43] <i>Set dig. out. A high</i> is executed. The input will go low whenever the Smart Logic Action [37] <i>Set dig. out. A low</i> is executed.
[120]	Local reference active	Output is high when par. 3-13 <i>Reference Site</i> = [2] Local or when par. 3-13 <i>Reference Site</i> = [0] <i>Linked to hand auto</i> at the same time as the LCP is in Hand on mode.
[121]	Remote reference active	Output is high when par. 3-13 <i>Reference Site</i> = Remote [1] or <i>Linked to hand/auto</i> [0] while the LCP is in [Auto on] mode.
[122]	No alarm	Output is high when no alarm is present.
[123]	Start command active	Output is high when there is an active Start command (i.e. via digital input bus connection or [Hand on] or [Auto on]), and no Stop or Start command is active.
[124]	Running reverse	Output is high when the frequency converter is running counter clockwise (the logical product of the status bits 'running' AND 'reverse').
[125]	Drive in hand mode	Output is high when the frequency converter is in Hand on mode (as indicated by the LED light above [Hand on]).
[126]	Drive in auto mode	Output is high when the frequency converter is in Hand on mode (as indicated by the LED light above [Auto on]).

#### 5-40 Function Relay

Array [9]

(Relay 1 [0], Relay 2 [1], Relay 3 [2], Relay 4 [3], Relay 5 [4], Relay 6 [5], Relay 6 [5], Relay 7 [6], Relay 8 [7], Relay 9 [8])

**Option:**

**Function:**

[0] *	No operation
[1]	Control ready
[2]	Drive ready
[3]	Drive rdy/rem ctrl
[4]	Enable / no warning
[5]	Running
[6]	Running / no warning
[7]	Run in range/no warn
[8]	Run on ref/no warn
[9]	Alarm

[10]	Alarm or warning
[11]	At torque limit
[12]	Out of current range
[13]	Below current, low
[14]	Above current, high
[15]	Out of speed range
[16]	Below speed, low
[17]	Above speed, high
[18]	Out of feedb. range
[19]	Below feedback, low
[20]	Above feedback, high
[21]	Thermal warning
[22]	Ready,no thermal W
[23]	Remote,ready,no TW
[24]	Ready, Voltage OK
[25]	Reverse
[26]	Bus OK
[27]	Torque limit & stop
[28]	Brake, no brake war
[29]	Brake ready, no fault
[30]	Brake fault (IGBT)
[31]	Relay 123
[32]	Mech brake ctrl
[33]	Safe stop active
[36]	Control word bit 11
[37]	Control word bit 12
[38]	Motor feedback error
[39]	Tracking error
[40]	Out of ref range
[41]	Below reference, low
[42]	Above ref, high
[43]	Extended PID Limit
[45]	Bus ctrl.
[46]	Bus ctrl, 1 if timeout
[47]	Bus ctrl, 0 if timeout
[51]	MCO controlled
[60]	Comparator 0
[61]	Comparator 1
[62]	Comparator 2
[63]	Comparator 3
[64]	Comparator 4
[65]	Comparator 5
[70]	Logic rule 0
[71]	Logic rule 1
[72]	Logic rule 2
[73]	Logic rule 3
[74]	Logic rule 4

[75]	Logic rule 5
[80]	SL digital output A
[81]	SL digital output B
[82]	SL digital output C
[83]	SL digital output D
[84]	SL digital output E
[85]	SL digital output F
[120]	Local ref active
[121]	Remote ref active
[122]	No alarm
[123]	Start command activ
[124]	Running reverse
[125]	Drive in hand mode
[126]	Drive in auto mode

## 14-22 Operation Mode

### Option:

### Function:

Use this parameter to specify normal operation; to perform tests; or to initialise all parameters except par. 15-03 *Power Up's*, par. 15-04 *Over Temp's* and par. 15-05 *Over Volt's*. This function is active only when the power is cycled to the frequency converter.

Select *Normal operation* [0] for normal operation of the frequency converter with the motor in the selected application.

Select *Control card test* [1] to test the analog and digital inputs and outputs and the +10 V control voltage. The test requires a test connector with internal connections. Use the following procedure for the control card test:

1. Select *Control card test* [1].
2. Disconnect the mains supply and wait for the light in the display to go out.
3. Set switches S201 (A53) and S202 (A54) = 'ON' / I.
4. Insert the test plug (see below).
5. Connect to mains supply.
6. Carry out various tests.
7. The results are displayed on the LCP and the frequency converter moves into an infinite loop.
8. Par.14-22 *Operation Mode* is automatically set to Normal operation. Carry out a power cycle to start up in Normal operation after a control card test.

#### If the test is OK:

LCP read-out: Control Card OK.

Disconnect the mains supply and remove the test plug. The green LED on the Control Card will light up.

#### If the test fails:

LCP read-out: Control Card I/O failure.

Replace the frequency converter or Control card. The red LED on the Control Card is turned on. Test plugs (connect the following terminals to each other): 18 - 27 - 32; 19 - 29 - 33; 42 - 53 - 54



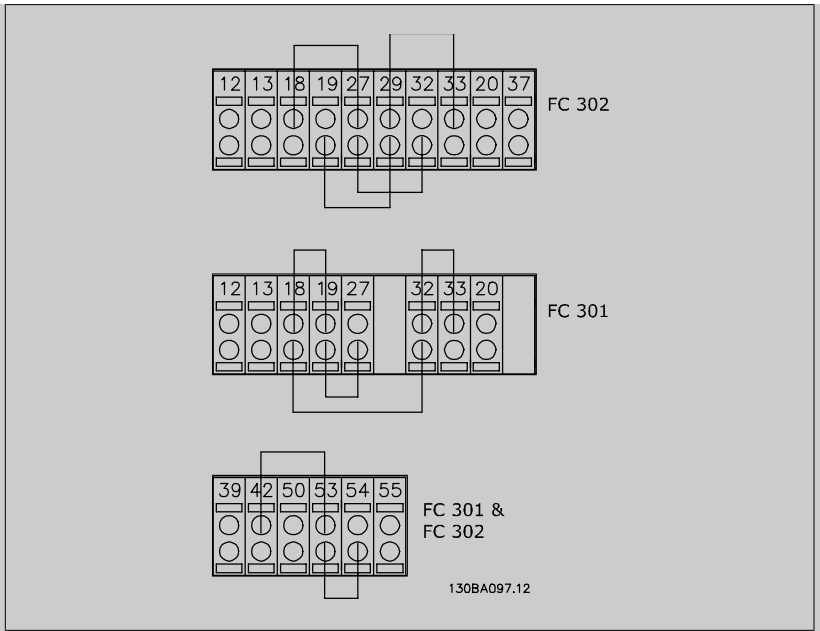

Select *Initialization* [2] to reset all parameter values to default settings, except for par. 15-03 *Power Up's*, par. 15-04 *Over Temp's*, and par. 15-05 *Over Volt's*. The frequency converter will reset during the next power-up.  
 Par.14-22 *Operation Mode* will also revert to the default setting *Normal operation* [0].

- [0] \* Normal operation
- [1] Control card test
- [2] Initialisation
- [3] Boot mode

**14-50 RFI Filter**

**Option:**

**Function:**

- [0] Off  
 Select *Off* [0] only if the frequency converter is fed by an isolated mains source, i.e. from a special IT mains source.  
 In this mode, the internal RFI filter capacitors between chassis and the mains RFI filter circuit are cut-out to avoid damage of the intermediate circuit and to reduce the ground capacity currents according to IEC 61800-3.
- [1] \* On  
 Select *On* [1] to ensure that the frequency converter complies with EMC standards.

**15-43 Software Version**

**Range:**

**Function:**

- 0 N/A\* [0 - 0 N/A]  
 View the combined SW version (or 'package version') consisting of power SW and control SW.

## 4.4 Parameter Lists

### Changes during operation

"TRUE" means that the parameter can be changed while the frequency converter is in operation and "FALSE" means that it must be stopped before a change can be made.

### 4-Set-up

'All set-up': the parameters can be set individually in each of the four set-ups, i.e. one single parameter can have four different data values.

'1 set-up': data value will be the same in all set-ups.

4

### Conversion index

This number refers to a conversion figure used when writing or reading to and from the frequency converter.

<b>Conv. index</b>	100	67	6	5	4	3	2	1	0	-1	-2	-3	-4	-5	-6
<b>Conv. factor</b>	1	1/60	1000000	100000	10000	1000	100	10	1	0.1	0.01	0.001	0.0001	0.00001	0.000001

Data type	Description	Type
2	Integer 8	Int8
3	Integer 16	Int16
4	Integer 32	Int32
5	Unsigned 8	UInt8
6	Unsigned 16	UInt16
7	Unsigned 32	UInt32
9	Visible String	VisStr
33	Normalized value 2 bytes	N2
35	Bit sequence of 16 boolean variables	V2
54	Time difference w/o date	TimD

See the frequency converter *Design Guide* for further information about data types 33, 35 and 54.

Parameters for the frequency converter are grouped into various parameter groups for easy selection of the correct parameters for optimized operation of the frequency converter.

0-\*\* Operation and Display parameters for basic frequency converter settings

1-\*\* Load and Motor parameters, includes all load and motor related parameters

2-\*\* Brake parameters

3-\*\* References and ramping parameters, includes DigiPot function

4-\*\* Limits Warnings, setting of limits and warning parameters

5-\*\* Digital inputs and outputs, includes relay controls

6-\*\* Analog inputs and outputs

7-\*\* Controls, setting parameters for speed and process controls

8-\*\* Communication and option parameters, setting of FC RS485 and FC USB port parameters.

9-\*\* Profibus parameters

10-\*\* DeviceNet and CAN Fieldbus parameters

13-\*\* Smart Logic Control parameters

14-\*\* Special function parameters

15-\*\* Drive information parameters

16-\*\* Read out parameters

17-\*\* Encoder Option parameters

32-\*\* MCO 305 Basic parameters

33-\*\* MCO 305 Advanced parameters

34-\*\* MCO Data Readout parameters

## 4.4.1 0- \*\* Operation/Display

Par. No. #	Parameter description	Default value	4-set-up	FC 302 only	Change during operation	Conversion index	Type
<b>0-0* Basic Settings</b>							
0-01	Language	[0] English	1 set-up		TRUE	-	Ujnt8
0-02	Motor Speed Unit	[0] RPM	2 set-ups		FALSE	-	Ujnt8
0-03	Regional Settings	[0] International	2 set-ups		FALSE	-	Ujnt8
0-04	Operating State at Power-up (Hand)	[1] Forced stop, ref=old	All set-ups		TRUE	-	Ujnt8
<b>0-1* Set-up Operations</b>							
0-10	Active Set-up	[1] Set-up 1	1 set-up		TRUE	-	Ujnt8
0-11	Edit Set-up	[1] Set-up 1	All set-ups		TRUE	-	Ujnt8
0-12	This Set-up Linked to	[0] Not linked	All set-ups		FALSE	-	Ujnt8
0-13	Readout: Linked Set-ups	0 N/A	All set-ups		FALSE	0	Ujnt16
0-14	Readout: Edit Set-ups / Channel	0 N/A	All set-ups		TRUE	0	Int32
<b>0-2* LCP Display</b>							
0-20	Display Line 1.1 Small	1617	All set-ups		TRUE	-	Ujnt16
0-21	Display Line 1.2 Small	1614	All set-ups		TRUE	-	Ujnt16
0-22	Display Line 1.3 Small	1610	All set-ups		TRUE	-	Ujnt16
0-23	Display Line 2 Large	1613	All set-ups		TRUE	-	Ujnt16
0-24	Display Line 3 Large	1602	All set-ups		TRUE	-	Ujnt16
0-25	My Personal Menu	SR	1 set-up		TRUE	0	Ujnt16
<b>0-3* LCP Custom Readout</b>							
0-30	Unit for User-defined Readout	[0] None	All set-ups		TRUE	-	Ujnt8
0-31	Min Value of User-defined Readout	0.00 CustomReadoutUnit	All set-ups		TRUE	-2	Int32
0-32	Max Value of User-defined Readout	100.00 CustomReadoutUnit	All set-ups		TRUE	-2	Int32
<b>0-4* LCP Keypad</b>							
0-40	[Hand on] Key on LCP	null	All set-ups		TRUE	-	Ujnt8
0-41	[Off] Key on LCP	null	All set-ups		TRUE	-	Ujnt8
0-42	[Auto on] Key on LCP	null	All set-ups		TRUE	-	Ujnt8
0-43	[Reset] Key on LCP	null	All set-ups		TRUE	-	Ujnt8
<b>0-5* Copy/Save</b>							
0-50	LCP Copy	[0] No copy	All set-ups		FALSE	-	Ujnt8
0-51	Set-up Copy	[0] No copy	All set-ups		FALSE	-	Ujnt8
<b>0-6* Password</b>							
0-60	Main Menu Password	100 N/A	1 set-up		TRUE	0	Int16
0-61	Access to Main Menu w/o Password	[0] Full access	1 set-up		TRUE	-	Ujnt8
0-65	Quick Menu Password	200 N/A	1 set-up		TRUE	0	Int16
0-66	Access to Quick Menu w/o Password	[0] Full access	1 set-up		TRUE	-	Ujnt8
0-67	Bus Password Access	0 N/A	All set-ups		TRUE	0	Ujnt16

### 4.4.2 1- \* Load/Motor

Par. No. #	Parameter description	Default value	4-set-up	FC 302 only	Change during operation	Conversion index	Type
<b>1-0* General Settings</b>							
1-00	Configuration Mode	null	All set-ups		TRUE	-	Uint8
1-01	Motor Control Principle	null	All set-ups		FALSE	-	Uint8
1-02	Flux Motor Feedback Source	[1] 24V encoder	All set-ups	x	FALSE	-	Uint8
1-03	Torque Characteristics	[0] Constant torque	All set-ups		TRUE	-	Uint8
1-04	Overload Mode	[0] High torque	All set-ups		FALSE	-	Uint8
1-05	Local Mode Configuration	[2] As mode par 1-00	All set-ups		TRUE	-	Uint8
1-06	Clockwise Direction	[0] Normal	All set-ups		FALSE	-	Uint8
<b>1-1* Motor Selection</b>							
1-10	Motor Construction	[0] Asynchron	All set-ups		FALSE	-	Uint8
<b>1-2* Motor Data</b>							
1-20	Motor Power [kW]	SR	All set-ups		FALSE	1	Uint32
1-21	Motor Power [HP]	SR	All set-ups		FALSE	-2	Uint32
1-22	Motor Voltage	SR	All set-ups		FALSE	0	Uint16
1-23	Motor Frequency	SR	All set-ups		FALSE	0	Uint16
1-24	Motor Current	SR	All set-ups		FALSE	-2	Uint32
1-25	Motor Nominal Speed	SR	All set-ups		FALSE	67	Uint16
1-26	Motor Cont. Rated Torque	SR	All set-ups		FALSE	-1	Uint32
1-29	Automatic Motor Adaptation (AMA)	[0] Off	All set-ups		FALSE	-	Uint8
<b>1-3* Adv. Motor Data</b>							
1-30	Stator Resistance (Rs)	SR	All set-ups		FALSE	-4	Uint32
1-31	Rotor Resistance (Rr)	SR	All set-ups		FALSE	-4	Uint32
1-33	Stator Leakage Reactance (X1)	SR	All set-ups		FALSE	-4	Uint32
1-34	Rotor Leakage Reactance (X2)	SR	All set-ups		FALSE	-4	Uint32
1-35	Main Reactance (Xh)	SR	All set-ups		FALSE	-4	Uint32
1-36	Iron Loss Resistance (Rfe)	SR	All set-ups		FALSE	-3	Uint32
1-37	d-axis Inductance (Ld)	SR	All set-ups	x	FALSE	-4	Int32
1-39	Motor Poles	SR	All set-ups		FALSE	0	Uint8
1-40	Back EMF at 1000 RPM	SR	All set-ups	x	FALSE	0	Uint16
1-41	Motor Angle Offset	0 N/A	All set-ups		FALSE	0	Int16
<b>1-5* Load Indep. Setting</b>							
1-50	Motor Magnetisation at Zero Speed	100 %	All set-ups		TRUE	0	Uint16
1-51	Min Speed Normal Magnetising [RPM]	SR	All set-ups		TRUE	67	Uint16
1-52	Min Speed Normal Magnetising [Hz]	SR	All set-ups		TRUE	-1	Uint16
1-53	Model Shift Frequency	SR	All set-ups	x	FALSE	-1	Uint16
1-54	Voltage reduction in fieldweakening	0 V	All set-ups		FALSE	0	Uint8
1-55	U/f Characteristic - U	SR	All set-ups		TRUE	-1	Uint16
1-56	U/f Characteristic - F	SR	All set-ups		TRUE	-1	Uint16
1-58	Flystart Test Pulses Current	100 %	All set-ups		FALSE	0	Uint16
1-59	Flystart Test Pulses Frequency	100 %	All set-ups		FALSE	0	Uint16

4

Par. No. #	Parameter description	Default value	4-set-up	FC 302 only	Change during operation	Conversion index	Type
<b>1-6* Load Depen. Setting</b>							
1-60	Low Speed Load Compensation	100 %	All set-ups		TRUE	0	Int16
1-61	High Speed Load Compensation	100 %	All set-ups		TRUE	0	Int16
1-62	Slip Compensation	SR	All set-ups		TRUE	0	Int16
1-63	Slip Compensation Time Constant	SR	All set-ups		TRUE	-2	Uint16
1-64	Resonance Dampening	100 %	All set-ups		TRUE	0	Uint16
1-65	Resonance Dampening Time Constant	5 ms	All set-ups		TRUE	-3	Uint8
1-66	Min. Current at Low Speed	100 %	All set-ups	x	TRUE	0	Uint8
1-67	Load Type	[0] Passive load	All set-ups	x	TRUE	-	Uint8
1-68	Minimum Inertia	SR	All set-ups	x	FALSE	-4	Uint32
1-69	Maximum Inertia	SR	All set-ups	x	FALSE	-4	Uint32
<b>1-7* Start Adjustments</b>							
1-71	Start Delay	0.0 s	All set-ups		TRUE	-1	Uint8
1-72	Start Function	[2] Coast/delay time	All set-ups		TRUE	-	Uint8
1-73	Flying Start	[0] Disabled	All set-ups		FALSE	-	Uint8
1-74	Start Speed [RPM]	SR	All set-ups		TRUE	67	Uint16
1-75	Start Speed [Hz]	SR	All set-ups		TRUE	-1	Uint16
1-76	Start Current	0.00 A	All set-ups		TRUE	-2	Uint32
<b>1-8* Stop Adjustments</b>							
1-80	Function at Stop	[0] Coast	All set-ups		TRUE	-	Uint8
1-81	Min Speed for Function at Stop [RPM]	SR	All set-ups		TRUE	67	Uint16
1-82	Min Speed for Function at Stop [Hz]	SR	All set-ups		TRUE	-1	Uint16
1-83	Precise Stop Function	[0] Precise ramp stop	All set-ups		FALSE	-	Uint8
1-84	Precise Stop Counter Value	100000 N/A	All set-ups		TRUE	0	Uint32
1-85	Precise Stop Speed Compensation Delay	10 ms	All set-ups		TRUE	-3	Uint8
<b>1-9* Motor Temperature</b>							
1-90	Motor Thermal Protection	[0] No protection	All set-ups		TRUE	-	Uint8
1-91	Motor External Fan	[0] No	All set-ups		TRUE	-	Uint16
1-93	Thermistor Resource	[0] None	All set-ups		TRUE	-	Uint8
1-95	KTY Sensor Type	[0] KTY Sensor 1	All set-ups	x	TRUE	-	Uint8
1-96	KTY Thermistor Resource	[0] None	All set-ups	x	TRUE	-	Uint8
1-97	KTY Threshold level	80 °C	1 set-up	x	TRUE	100	Int16

### 4.4.3 2- \*\* Brakes

Par. No. #	Parameter description	Default value	4-set-up	FC 302 only	Change during operation	Conversion index	Type
<b>2-0* DC-Brake</b>							
2-01	DC Hold Current	50 %	All set-ups		TRUE	0	Uint8
2-01	DC Brake Current	50 %	All set-ups		TRUE	0	Uint16
2-02	DC Braking Time	10.0 s	All set-ups		TRUE	-1	Uint16
2-03	DC Brake Cut In Speed [RPM]	SR	All set-ups		TRUE	67	Uint16
2-04	DC Brake Cut In Speed [Hz]	SR	All set-ups		TRUE	-1	Uint16
2-05	Maximum Reference	MaxReference (P303)	All set-ups		TRUE	-3	Int32
<b>2-1* Brake Energy Funct.</b>							
2-10	Brake Function	null	All set-ups		TRUE	-	Uint8
2-11	Brake Resistor (ohm)	SR	All set-ups		TRUE	0	Uint16
2-12	Brake Power Limit (kW)	SR	All set-ups		TRUE	0	Uint32
2-13	Brake Power Monitoring	[0] Off	All set-ups		TRUE	-	Uint8
2-15	Brake Check	[0] Off	All set-ups		TRUE	-	Uint8
2-16	AC brake Max. Current	100.0 %	All set-ups		TRUE	-1	Uint32
2-17	Over-voltage Control	[0] Disabled	All set-ups		TRUE	-	Uint8
2-18	Brake Check Condition	[0] At Power Up	All set-ups		TRUE	-	Uint8
<b>2-2* Mechanical Brake</b>							
2-20	Release Brake Current	ImaxVLT (P1637)	All set-ups		TRUE	-2	Uint32
2-21	Activate Brake Speed [RPM]	SR	All set-ups		TRUE	67	Uint16
2-22	Activate Brake Speed [Hz]	SR	All set-ups		TRUE	-1	Uint16
2-23	Activate Brake Delay	0.0 s	All set-ups		TRUE	-1	Uint8
2-24	Stop Delay	0.0 s	All set-ups		TRUE	-1	Uint8
2-25	Brake Release Time	0.20 s	All set-ups		TRUE	-2	Uint16
2-26	Torque Ref	0.00 %	All set-ups		TRUE	-2	Int16
2-27	Torque Ramp Time	0.2 s	All set-ups		TRUE	-1	Uint8
2-28	Gain Boost Factor	1.00 N/A	All set-ups		TRUE	-2	Uint16

#### 4.4.4 3- \*\* Reference / Ramps

Par. No. #	Parameter description	Default value	4-set-up	FC 302 only	Change during operation	Conversion index	Type
<b>3-0* Reference Limits</b>							
3-00	Reference Range	null	All set-ups		TRUE	-	Uimt8
3-01	Reference/Feedback Unit	null	All set-ups		TRUE	-	Uimt8
3-02	Minimum Reference	SR	All set-ups		TRUE	-3	Int32
3-03	Maximum Reference	SR	All set-ups		TRUE	-3	Int32
3-04	Reference Function	[0] Sum	All set-ups		TRUE	-	Uimt8
<b>3-1* References</b>							
3-10	Preset Reference	0.00 %	All set-ups		TRUE	-2	Int16
3-11	Jog Speed [Hz]	SR	All set-ups		TRUE	-1	Uimt16
3-12	Catch up/slow Down Value	0.00 %	All set-ups		TRUE	-2	Int16
3-13	Reference Site	[0] Linked to Hand / Auto	All set-ups		TRUE	-	Uimt8
3-14	Preset Relative Reference	0.00 %	All set-ups		TRUE	-2	Int32
3-15	Reference Resource 1	null	All set-ups		TRUE	-	Uimt8
3-16	Reference Resource 2	null	All set-ups		TRUE	-	Uimt8
3-17	Reference Resource 3	null	All set-ups		TRUE	-	Uimt8
3-18	Relative Scaling Reference Resource	[0] No function	All set-ups		TRUE	-	Uimt8
3-19	Jog Speed [RPM]	SR	All set-ups		TRUE	67	Uimt16
<b>3-4* Ramp 1</b>							
3-40	Ramp 1 Type	[0] Linear	All set-ups		TRUE	-	Uimt8
3-41	Ramp 1 Ramp up Time	SR	All set-ups		TRUE	-2	Uimt32
3-42	Ramp 1 Ramp Down Time	SR	All set-ups		TRUE	-2	Uimt32
3-43	Ramp 1 S-ramp Ratio at Accel. Start	50 %	All set-ups		TRUE	0	Uimt8
3-44	Ramp 1 S-ramp Ratio at Decel. Start	50 %	All set-ups		TRUE	0	Uimt8
3-45	Ramp 1 S-ramp Ratio at Accel. End	50 %	All set-ups		TRUE	0	Uimt8
3-46	Ramp 1 S-ramp Ratio at Decel. End	50 %	All set-ups		TRUE	0	Uimt8
<b>3-5* Ramp 2</b>							
3-50	Ramp 2 Type	[0] Linear	All set-ups		TRUE	-	Uimt8
3-51	Ramp 2 Ramp up Time	SR	All set-ups		TRUE	-2	Uimt32
3-52	Ramp 2 Ramp down Time	SR	All set-ups		TRUE	-2	Uimt32
3-53	Ramp 2 S-ramp Ratio at Accel. Start	50 %	All set-ups		TRUE	0	Uimt8
3-54	Ramp 2 S-ramp Ratio at Decel. Start	50 %	All set-ups		TRUE	0	Uimt8
3-55	Ramp 2 S-ramp Ratio at Accel. End	50 %	All set-ups		TRUE	0	Uimt8
3-56	Ramp 2 S-ramp Ratio at Decel. End	50 %	All set-ups		TRUE	0	Uimt8
3-57	Ramp 2 S-ramp Ratio at Accel. Start	50 %	All set-ups		TRUE	0	Uimt8
3-58	Ramp 2 S-ramp Ratio at Decel. End	50 %	All set-ups		TRUE	0	Uimt8



Par. No. #	Parameter description	Default value	4-set-up	FC 302 only	Change during operation	Conversion index	Type
<b>3-6* Ramp 3</b>							
3-60	Ramp 3 Type	[0] Linear	All set-ups		TRUE	-	Ujnt8
3-61	Ramp 3 Ramp up Time	SR	All set-ups		TRUE	-2	Ujnt32
3-62	Ramp 3 Ramp down Time	SR	All set-ups		TRUE	-2	Ujnt32
3-65	Ramp 3 S-ramp Ratio at Accel. Start	50 %	All set-ups		TRUE	0	Ujnt8
3-66	Ramp 3 S-ramp Ratio at Accel. End	50 %	All set-ups		TRUE	0	Ujnt8
3-67	Ramp 3 S-ramp Ratio at Decel. Start	50 %	All set-ups		TRUE	0	Ujnt8
3-68	Ramp 3 S-ramp Ratio at Decel. End	50 %	All set-ups		TRUE	0	Ujnt8
<b>3-7* Ramp 4</b>							
3-70	Ramp 4 Type	[0] Linear	All set-ups		TRUE	-	Ujnt8
3-71	Ramp 4 Ramp up Time	SR	All set-ups		TRUE	-2	Ujnt32
3-72	Ramp 4 Ramp Down Time	SR	All set-ups		TRUE	-2	Ujnt32
3-75	Ramp 4 S-ramp Ratio at Accel. Start	50 %	All set-ups		TRUE	0	Ujnt8
3-76	Ramp 4 S-ramp Ratio at Accel. End	50 %	All set-ups		TRUE	0	Ujnt8
3-77	Ramp 4 S-ramp Ratio at Decel. Start	50 %	All set-ups		TRUE	0	Ujnt8
3-78	Ramp 4 S-ramp Ratio at Decel. End	50 %	All set-ups		TRUE	0	Ujnt8
<b>3-8* Other Ramps</b>							
3-80	Jog Ramp Time	SR	All set-ups		TRUE	-2	Ujnt32
3-81	Quick Stop Ramp Time	SR	2 set-ups		TRUE	-2	Ujnt32
3-82	Quick Stop Ramp Type	[0] Linear	All set-ups		TRUE	-	Ujnt8
3-83	Quick Stop S-ramp Ratio at Decel. Start	50 %	All set-ups		TRUE	0	Ujnt8
3-84	Quick Stop S-ramp Ratio at Decel. End	50 %	All set-ups		TRUE	0	Ujnt8
<b>3-9* Digital Pot. Meter</b>							
3-90	Step Size	0.10 %	All set-ups		TRUE	-2	Ujnt16
3-91	Ramp Time	1.00 s	All set-ups		TRUE	-2	Ujnt32
3-92	Power Restore	[0] Off	All set-ups		TRUE	-	Ujnt8
3-93	Maximum Limit	100 %	All set-ups		TRUE	0	Int16
3-94	Minimum Limit	-100 %	All set-ups		TRUE	0	Int16
3-95	Ramp Delay	SR	All set-ups		TRUE	-3	TimD

**4.4.5 4- \* Limits / Warnings**

Par. No. #	Parameter description	Default value	4-set-up	FC 302 only	Change during operation	Conversion index	Type
<b>4-1* Motor Limits</b>							
4-10	Motor Speed Direction	null	All set-ups		FALSE	-	Uint8
4-11	Motor Speed Low Limit [RPM]	SR	All set-ups		TRUE	67	Uint16
4-12	Motor Speed Low Limit [Hz]	SR	All set-ups		TRUE	-1	Uint16
4-13	Motor Speed High Limit [RPM]	SR	All set-ups		TRUE	67	Uint16
4-14	Motor Speed High Limit [Hz]	SR	All set-ups		TRUE	-1	Uint16
4-16	Torque Limit Motor Mode	SR	All set-ups		TRUE	-1	Uint16
4-17	Torque Limit Generator Mode	100.0 %	All set-ups		TRUE	-1	Uint16
4-18	Current Limit	SR	All set-ups		TRUE	-1	Uint32
4-19	Max Output Frequency	132.0 Hz	All set-ups		FALSE	-1	Uint16
<b>4-2* Limit Factors</b>							
4-20	Torque Limit Factor Source	[0] No function	All set-ups		TRUE	-	Uint8
4-21	Speed Limit Factor Source	[0] No function	All set-ups		TRUE	-	Uint8
<b>4-3* Motor Speed Mon.</b>							
4-30	Motor Feedback Loss Function	[2] Trip	All set-ups		TRUE	-	Uint8
4-31	Motor Feedback Speed Error	300 RPM	All set-ups		TRUE	67	Uint16
4-32	Motor Feedback Loss Timeout	0.05 s	All set-ups		TRUE	-2	Uint16
4-34	Tracking Error Function	[0] Disable	All set-ups		TRUE	-	Uint8
4-35	Tracking Error	10 RPM	All set-ups		TRUE	67	Uint16
4-36	Tracking Error Timeout	1.00 s	All set-ups		TRUE	-2	Uint16
4-37	Tracking Error Ramping	100 RPM	All set-ups		TRUE	67	Uint16
4-38	Tracking Error Ramping Timeout	1.00 s	All set-ups		TRUE	-2	Uint16
4-39	Tracking Error After Ramping Timeout	5.00 s	All set-ups		TRUE	-2	Uint16
<b>4-5* Adj. Warnings</b>							
4-50	Warning Current Low	0.00 A	All set-ups		TRUE	-2	Uint32
4-51	Warning Current High	ImaxVLT (P1637)	All set-ups		TRUE	-2	Uint32
4-52	Warning Speed Low	0 RPM	All set-ups		TRUE	67	Uint16
4-53	Warning Speed High	outputSpeedHighLimit (P413)	All set-ups		TRUE	67	Uint16
4-54	Warning Reference Low	-999999.999 N/A	All set-ups		TRUE	-3	Int32
4-55	Warning Reference High	999999.999 N/A	All set-ups		TRUE	-3	Int32
4-56	Warning Feedback Low	-999999.999 ReferenceFeedbackUnit	All set-ups		TRUE	-3	Int32
4-57	Warning Feedback High	999999.999 ReferenceFeedbackUnit	All set-ups		TRUE	-3	Int32
4-58	Missing Motor Phase Function	null	All set-ups		TRUE	-	Uint8
<b>4-6* Speed Bypass</b>							
4-60	Bypass Speed From [RPM]	SR	All set-ups		TRUE	67	Uint16
4-61	Bypass Speed From [Hz]	SR	All set-ups		TRUE	-1	Uint16
4-62	Bypass Speed To [RPM]	SR	All set-ups		TRUE	67	Uint16
4-63	Bypass Speed To [Hz]	SR	All set-ups		TRUE	-1	Uint16

### 4.4.6 5- \* \* Digital In/Out

Par. No. #	Parameter description	Default value	4-set-up	FC 302 only	Change during operation	Conversion index	Type
<b>5-0* Digital I/O mode</b>							
5-00	Digital I/O Mode	[0] PNP	All set-ups		FALSE	-	Ujnt8
5-01	Terminal 27 Mode	[0] Input	All set-ups		TRUE	-	Ujnt8
5-02	Terminal 29 Mode	[0] Input	All set-ups	x	TRUE	-	Ujnt8
<b>5-1* Digital Inputs</b>							
5-10	Terminal 18 Digital Input	null	All set-ups		TRUE	-	Ujnt8
5-11	Terminal 19 Digital Input	null	All set-ups		TRUE	-	Ujnt8
5-12	Terminal 27 Digital Input	null	All set-ups		TRUE	-	Ujnt8
5-13	Terminal 29 Digital Input	null	All set-ups	x	TRUE	-	Ujnt8
5-14	Terminal 32 Digital Input	null	All set-ups		TRUE	-	Ujnt8
5-15	Terminal 33 Digital Input	null	All set-ups		TRUE	-	Ujnt8
5-16	Terminal X30/2 Digital Input	null	All set-ups		TRUE	-	Ujnt8
5-17	Terminal X30/3 Digital Input	null	All set-ups		TRUE	-	Ujnt8
5-18	Terminal X30/4 Digital Input	null	All set-ups		TRUE	-	Ujnt8
5-19	Terminal 37 Safe Stop	[1] Safe Stop Alarm	1 set-up		TRUE	-	Ujnt8
5-20	Terminal X46/1 Digital Input	[0] No operation	All set-ups		TRUE	-	Ujnt8
5-21	Terminal X46/3 Digital Input	[0] No operation	All set-ups		TRUE	-	Ujnt8
5-22	Terminal X46/5 Digital Input	[0] No operation	All set-ups		TRUE	-	Ujnt8
5-23	Terminal X46/7 Digital Input	[0] No operation	All set-ups		TRUE	-	Ujnt8
5-24	Terminal X46/9 Digital Input	[0] No operation	All set-ups		TRUE	-	Ujnt8
5-25	Terminal X46/11 Digital Input	[0] No operation	All set-ups		TRUE	-	Ujnt8
5-26	Terminal X46/13 Digital Input	[0] No operation	All set-ups		TRUE	-	Ujnt8
<b>5-3* Digital Outputs</b>							
5-30	Terminal 27 Digital Output	null	All set-ups		TRUE	-	Ujnt8
5-31	Terminal 29 Digital Output	null	All set-ups	x	TRUE	-	Ujnt8
5-32	Term X30/6 Digi Out (MCB 101)	null	All set-ups		TRUE	-	Ujnt8
5-33	Term X30/7 Digi Out (MCB 101)	null	All set-ups		TRUE	-	Ujnt8
<b>5-4* Relays</b>							
5-40	Function Relay	null	All set-ups		TRUE	-	Ujnt8
5-41	On Delay, Relay	0.01 s	All set-ups		TRUE	-2	Ujnt16
5-42	Off Delay, Relay	0.01 s	All set-ups		TRUE	-2	Ujnt16

Par. No. #	Parameter description	Default value	4-set-up	FC 302 only	Change during operation	Conversion index	Type
<b>5-5* Pulse Input</b>							
5-50	Term. 29 Low Frequency	100 Hz	All set-ups	x	TRUE	0	Uint32
5-51	Term. 29 High Frequency	100 Hz	All set-ups	x	TRUE	0	Uint32
5-52	Term. 29 Low Ref./Feedb. Value	0.000 ReferenceFeedbackUnit	All set-ups	x	TRUE	-3	Int32
5-53	Term. 29 High Ref./Feedb. Value	SR	All set-ups	x	TRUE	-3	Int32
5-54	Pulse Filter Time Constant #29	100 ms	All set-ups	x	FALSE	-3	Uint16
5-55	Term. 33 Low Frequency	100 Hz	All set-ups	x	TRUE	0	Uint32
5-56	Term. 33 High Frequency	100 Hz	All set-ups	x	TRUE	0	Uint32
5-57	Term. 33 Low Ref./Feedb. Value	0.000 ReferenceFeedbackUnit	All set-ups	x	TRUE	-3	Int32
5-58	Term. 33 High Ref./Feedb. Value	SR	All set-ups	x	TRUE	-3	Int32
5-59	Pulse Filter Time Constant #33	100 ms	All set-ups	x	FALSE	-3	Uint16
<b>5-6* Pulse Output</b>							
5-60	Terminal 27 Pulse Output Variable	null	All set-ups		TRUE	-	Uint8
5-62	Pulse Output Max Freq #27	SR	All set-ups		TRUE	0	Uint32
5-63	Terminal 29 Pulse Output Variable	null	All set-ups	x	TRUE	-	Uint8
5-65	Pulse Output Max Freq #29	SR	All set-ups	x	TRUE	0	Uint32
5-66	Terminal X30/6 Pulse Output Variable	null	All set-ups		TRUE	-	Uint8
5-68	Pulse Output Max Freq #X30/6	SR	All set-ups		TRUE	0	Uint32
<b>5-7* 24V Encoder Input</b>							
5-70	Term 32/33 Pulses per Revolution	1024 N/A	All set-ups		FALSE	0	Uint16
5-71	Term 32/33 Encoder Direction	[0] Clockwise	All set-ups		FALSE	-	Uint8
<b>5-9* Bus Controlled</b>							
<b>Digital &amp; Relay Bus Control</b>							
5-93	Pulse Out #27 Bus Control	0 N/A	All set-ups		TRUE	0	Uint32
5-94	Pulse Out #27 Timeout Preset	0.00 %	All set-ups		TRUE	-2	N2
5-95	Pulse Out #29 Bus Control	0.00 %	1 set-up		TRUE	-2	Uint16
5-96	Pulse Out #29 Timeout Preset	0.00 %	All set-ups	x	TRUE	-2	N2
5-97	Pulse Out #X30/6 Bus Control	0.00 %	1 set-up		TRUE	-2	Uint16
5-98	Pulse Out #X30/6 Timeout Preset	0.00 %	All set-ups	x	TRUE	-2	N2
			1 set-up		TRUE	-2	Uint16

### 4.4.7 6- \*\* Analog In/Out

Par. No. #	Parameter description	Default value	4-set-up	FC 302 only	Change during operation	Conversion index	Type
<b>6-0* Analog I/O Mode</b>							
6-00	Live Zero Timeout Time	10 s	All set-ups		TRUE	0	Uint8
6-01	Live Zero Timeout Function	[0] Off	All set-ups		TRUE	-	Uint8
<b>6-1* Analog Input 1</b>							
6-10	Terminal 53 Low Voltage	0.07 V	All set-ups		TRUE	-2	Int16
6-11	Terminal 53 High Voltage	10.00 V	All set-ups		TRUE	-2	Int16
6-12	Terminal 53 Low Current	0.14 mA	All set-ups		TRUE	-5	Int16
6-13	Terminal 53 High Current	20.00 mA	All set-ups		TRUE	-5	Int16
6-14	Terminal 53 Low Ref./Feedb. Value	0 ReferenceFeedbackUnit	All set-ups		TRUE	-3	Int32
6-15	Terminal 53 High Ref./Feedb. Value	SR	All set-ups		TRUE	-3	Int32
6-16	Terminal 53 Filter Time Constant	0.001 s	All set-ups		TRUE	-3	Uint16
<b>6-2* Analog Input 2</b>							
6-20	Terminal 54 Low Voltage	0.07 V	All set-ups		TRUE	-2	Int16
6-21	Terminal 54 High Voltage	10.00 V	All set-ups		TRUE	-2	Int16
6-22	Terminal 54 Low Current	0.14 mA	All set-ups		TRUE	-5	Int16
6-23	Terminal 54 High Current	20.00 mA	All set-ups		TRUE	-5	Int16
6-24	Terminal 54 Low Ref./Feedb. Value	0 ReferenceFeedbackUnit	All set-ups		TRUE	-3	Int32
6-25	Terminal 54 High Ref./Feedb. Value	SR	All set-ups		TRUE	-3	Int32
6-26	Terminal 54 Filter Time Constant	0.001 s	All set-ups		TRUE	-3	Uint16
<b>6-3* Analog Input 3</b>							
6-30	Terminal X30/11 Low Voltage	0.07 V	All set-ups		TRUE	-2	Int16
6-31	Terminal X30/11 High Voltage	10.00 V	All set-ups		TRUE	-2	Int16
6-34	Term. X30/11 Low Ref./Feedb. Value	0 ReferenceFeedbackUnit	All set-ups		TRUE	-3	Int32
6-35	Term. X30/11 High Ref./Feedb. Value	SR	All set-ups		TRUE	-3	Int32
6-36	Term. X30/11 Filter Time Constant	0.001 s	All set-ups		TRUE	-3	Uint16
<b>6-4* Analog Input 4</b>							
6-40	Terminal X30/12 Low Voltage	0.07 V	All set-ups		TRUE	-2	Int16
6-41	Terminal X30/12 High Voltage	10.00 V	All set-ups		TRUE	-2	Int16
6-44	Term. X30/12 Low Ref./Feedb. Value	0 ReferenceFeedbackUnit	All set-ups		TRUE	-3	Int32
6-45	Term. X30/12 High Ref./Feedb. Value	SR	All set-ups		TRUE	-3	Int32
6-46	Term. X30/12 Filter Time Constant	0.001 s	All set-ups		TRUE	-3	Uint16
<b>6-5* Analog Output 1</b>							
6-50	Terminal 42 Output	null	All set-ups		TRUE	-	Uint8
6-51	Terminal 42 Output Min Scale	0.00 %	All set-ups		TRUE	-2	Int16
6-52	Terminal 42 Output Max Scale	100.00 %	All set-ups		TRUE	-2	Int16
6-53	Terminal 42 Output Bus Control	0.00 %	All set-ups		TRUE	-2	N2
6-54	Terminal 42 Output Timeout Preset	0.00 %	1 set-up		TRUE	-2	Uint16
6-55	Terminal 42 Output Filter	[0] Off	1 set-up		TRUE	-	Uint8

Par. No. #	Parameter description	Default value	4-set-up	FC 302 only	Change during operation	Conversion index	Type
<b>6-6* Analog Output 2</b>							
6-60	Terminal X30/8 Output	null	All set-ups		TRUE	-	Uint8
6-61	Terminal X30/8 Min. Scale	0.00 %	All set-ups		TRUE	-2	Int16
6-62	Terminal X30/8 Max. Scale	100.00 %	All set-ups		TRUE	-2	Int16
6-63	Terminal X30/8 Bus Control	0.00 %	All set-ups		TRUE	-2	N2
6-64	Terminal X30/8 Output Timeout Preset	0.00 %	1 set-up		TRUE	-2	Uint16
<b>6-7* Analog Output 3</b>							
6-70	Terminal X45/1 Output	null	All set-ups		TRUE	-	Uint8
6-71	Terminal X45/1 Min. Scale	0.00 %	All set-ups		TRUE	-2	Int16
6-72	Terminal X45/1 Max. Scale	100.00 %	All set-ups		TRUE	-2	Int16
6-73	Terminal X45/1 Bus Control	0.00 %	All set-ups		TRUE	-2	N2
6-74	Terminal X45/1 Output Timeout Preset	0.00 %	1 set-up		TRUE	-2	Uint16
<b>6-8* Analog Output 4</b>							
6-80	Terminal X45/3 Output	null	All set-ups		TRUE	-	Uint8
6-81	Terminal X45/3 Min. Scale	0.00 %	All set-ups		TRUE	-2	Int16
6-82	Terminal X45/3 Max. Scale	100.00 %	All set-ups		TRUE	-2	Int16
6-83	Terminal X45/3 Bus Control	0.00 %	All set-ups		TRUE	-2	N2
6-84	Terminal X45/3 Output Timeout Preset	0.00 %	1 set-up		TRUE	-2	Uint16

### 4.4.8 7- \* \* Controllers

Par. No. #	Parameter description	Default value	4-set-up	FC 302 only	Change during operation	Conversion index	Type
<b>7-0* Speed PID Ctrl.</b>							
7-00	Speed PID Feedback Source	null	All set-ups		FALSE	-	Ujnt8
7-02	Speed PID Proportional Gain	SR	All set-ups		TRUE	-3	Ujnt16
7-03	Speed PID Integral Time	SR	All set-ups		TRUE	-4	Ujnt32
7-04	Speed PID Differentiation Time	SR	All set-ups		TRUE	-4	Ujnt16
7-05	Speed PID Diff. Gain Limit	5.0 N/A	All set-ups		TRUE	-1	Ujnt16
7-06	Speed PID Lowpass Filter Time	SR	All set-ups		TRUE	-4	Ujnt16
7-07	Speed PID Feedback Gear Ratio	1.0000 N/A	All set-ups		FALSE	-4	Ujnt32
7-08	Speed PID Feed Forward Factor	0 %	All set-ups		FALSE	0	Ujnt16
<b>7-1* Torque PI Ctrl.</b>							
7-12	Torque PI Proportional Gain	100 %	All set-ups		TRUE	0	Ujnt16
7-13	Torque PI Integration Time	0.020 s	All set-ups		TRUE	-3	Ujnt16
<b>7-2* Process Ctrl. Feeds</b>							
7-20	Process CL Feedback 1 Resource	[0] No function	All set-ups		TRUE	-	Ujnt8
7-22	Process CL Feedback 2 Resource	[0] No function	All set-ups		TRUE	-	Ujnt8
<b>7-3* Process PID Ctrl.</b>							
7-30	Process PID Normal/ Inverse Control	[0] Normal	All set-ups		TRUE	-	Ujnt8
7-31	Process PID Anti Windup	[1] On	All set-ups		TRUE	-	Ujnt8
7-32	Process PID Start Speed	0 RPM	All set-ups		TRUE	67	Ujnt16
7-33	Process PID Proportional Gain	0.01 N/A	All set-ups		TRUE	-2	Ujnt16
7-34	Process PID Integral Time	10000.00 s	All set-ups		TRUE	-2	Ujnt32
7-35	Process PID Differentiation Time	0.00 s	All set-ups		TRUE	-2	Ujnt16
7-36	Process PID Diff. Gain Limit	5.0 N/A	All set-ups		TRUE	-1	Ujnt16
7-38	Process PID Feed Forward Factor	0 %	All set-ups		TRUE	0	Ujnt16
7-39	On Reference Bandwidth	5 %	All set-ups		TRUE	0	Ujnt8
<b>7-4* Adv. Process PID I</b>							
7-40	Process PID I-part Reset	[0] No	All set-ups		TRUE	-	Ujnt8
7-41	Process PID Output Neg. Clamp	-100 %	All set-ups		TRUE	0	Int16
7-42	Process PID Output Pos. Clamp	100 %	All set-ups		TRUE	0	Int16
7-43	Process PID Gain Scale at Min. Ref.	100 %	All set-ups		TRUE	0	Int16
7-44	Process PID Gain Scale at Max. Ref.	100 %	All set-ups		TRUE	0	Int16
7-45	Process PID Feed Fwd Resource	[0] No function	All set-ups		TRUE	-	Ujnt8
7-46	Process PID Feed Fwd Normal/ Inv. Ctrl.	[0] Normal	All set-ups		TRUE	-	Ujnt8
7-49	Process PID Output Normal/ Inv. Ctrl.	[0] Normal	All set-ups		TRUE	-	Ujnt8
<b>7-5* Adv. Process PID II</b>							
7-50	Process PID Extended PID	[1] Enabled	All set-ups		TRUE	-	Ujnt8
7-51	Process PID Feed Fwd Gain	1.00 N/A	All set-ups		TRUE	-2	Ujnt16
7-52	Process PID Feed Fwd Ramp up	0.01 s	All set-ups		TRUE	-2	Ujnt32
7-53	Process PID Feed Fwd Ramp down	0.01 s	All set-ups		TRUE	-2	Ujnt32
7-56	Process PID Ref. Filter Time	0.001 s	All set-ups		TRUE	-3	Ujnt16
7-57	Process PID Fb. Filter Time	0.001 s	All set-ups		TRUE	-3	Ujnt16

4.4.9 8- \* Comm. and Options

Par. No. #	Parameter description	Default value	4-set-up	FC 302 only	Change during operation	Conversion index	Type
<b>8-0* General Settings</b>							
8-01	Control Site	[0] Digital and ctrl.word	All set-ups		TRUE	-	Ujnt8
8-02	Control Word Source	null	All set-ups		TRUE	-	Ujnt8
8-03	Control Word Timeout Time	1.0 s	1 set-up		TRUE	-1	Ujnt32
8-04	Control Word Timeout Function	null	1 set-up		TRUE	-	Ujnt8
8-05	End-of-Timeout Function	[1] Resume set-up	1 set-up		TRUE	-	Ujnt8
8-06	Reset Control Word Timeout	[0] Do not reset	All set-ups		TRUE	-	Ujnt8
8-07	Diagnosis Trigger	[0] Disable	2 set-ups		TRUE	-	Ujnt8
<b>8-1* Ctrl. Word Settings</b>							
8-10	Control Word Profile	[0] FC profile	All set-ups		TRUE	-	Ujnt8
8-13	Configurable Status Word STW	null	All set-ups		TRUE	-	Ujnt8
8-14	Configurable Control Word CTW	[1] Profile default	All set-ups		TRUE	-	Ujnt8
<b>8-3* FC Port Settings</b>							
8-30	Protocol	[0] FC	1 set-up		TRUE	-	Ujnt8
8-31	Address	1 N/A	1 set-up		TRUE	0	Ujnt8
8-32	FC Port Baud Rate	null	1 set-up		TRUE	-	Ujnt8
8-33	Parity / Stop Bits	[0] Even Parity, 1 Stop Bit	1 set-up		TRUE	-	Ujnt8
8-34	Estimated cycle time	0 ms	2 set-ups		TRUE	-3	Ujnt32
8-35	Minimum Response Delay	10 ms	All set-ups		TRUE	-3	Ujnt16
8-36	Max Response Delay	SR	1 set-up		TRUE	-3	Ujnt16
8-37	Max Inter-Char Delay	SR	1 set-up		TRUE	-5	Ujnt16
<b>8-4* FC MC protocol set</b>							
8-40	Telegram selection	[1] Standard telegram 1	2 set-ups		TRUE	-	Ujnt8
8-41	Parameters for signals	0	All set-ups		FALSE	-	Ujnt16
8-42	PCD write configuration	SR	All set-ups		TRUE	-	Ujnt16
8-43	PCD read configuration	SR	All set-ups		TRUE	-	Ujnt16
<b>8-5* Digital/Bus</b>							
8-50	Coasting Select	[3] Logic OR	All set-ups		TRUE	-	Ujnt8
8-51	Quick Stop Select	[3] Logic OR	All set-ups		TRUE	-	Ujnt8
8-52	DC Brake Select	[3] Logic OR	All set-ups		TRUE	-	Ujnt8
8-53	Start Select	[3] Logic OR	All set-ups		TRUE	-	Ujnt8
8-54	Reversing Select	[3] Logic OR	All set-ups		TRUE	-	Ujnt8
8-55	Set-up Select	[3] Logic OR	All set-ups		TRUE	-	Ujnt8
8-56	Preset Reference Select	[3] Logic OR	All set-ups		TRUE	-	Ujnt8
<b>8-8* FC Port Diagnostics</b>							
8-80	Bus Message Count	0 N/A	All set-ups		TRUE	0	Ujnt32
8-81	Bus Error Count	0 N/A	All set-ups		TRUE	0	Ujnt32
8-82	Slave Messages Rcvd	0 N/A	All set-ups		TRUE	0	Ujnt32
8-83	Slave Error Count	0 N/A	All set-ups		TRUE	0	Ujnt32
<b>8-9* Bus Jog</b>							
8-90	Bus Jog 1 Speed	100 RPM	All set-ups		TRUE	67	Ujnt16
8-91	Bus Jog 2 Speed	200 RPM	All set-ups		TRUE	67	Ujnt16



### 4.4.10 9- \* \* Profibus

Par. No. #	Parameter description	Default value	4-set-up	FC 302 only	Change during operation	Conversion index	Type
9-00	Setpoint	0 N/A	All set-ups		TRUE	0	Uint16
9-07	Actual Value	0 N/A	All set-ups		FALSE	0	Uint16
9-15	PCD Write Configuration	SR	2 set-ups		TRUE	-	Uint16
9-16	PCD Read Configuration	SR	2 set-ups		TRUE	-	Uint16
9-18	Node Address	126 N/A	1 set-up		TRUE	0	Uint8
9-22	Telegram Selection	[108] PPO 8	1 set-up		TRUE	-	Uint8
9-23	Parameters for Signals	0	All set-ups		TRUE	-	Uint16
9-27	Parameter Edit	[1] Enabled	2 set-ups		FALSE	-	Uint16
9-28	Process Control	[1] Enable cyclic master	2 set-ups		FALSE	-	Uint8
9-44	Fault Message Counter	0 N/A	All set-ups		TRUE	0	Uint16
9-45	Fault Code	0 N/A	All set-ups		TRUE	0	Uint16
9-47	Fault Number	0 N/A	All set-ups		TRUE	0	Uint16
9-52	Fault Situation Counter	0 N/A	All set-ups		TRUE	0	Uint16
9-53	Profibus Warning Word	0 N/A	All set-ups		TRUE	0	Uint16
9-63	Actual Baud Rate	[255] No baudrate found	All set-ups		TRUE	-	Uint8
9-64	Device Identification	0 N/A	All set-ups		TRUE	0	Uint16
9-65	Profile Number	0 N/A	All set-ups		TRUE	0	OctStr[2]
9-67	Control Word 1	0 N/A	All set-ups		TRUE	0	V2
9-68	Status Word 1	0 N/A	All set-ups		TRUE	0	V2
9-71	Profibus Save Data Values	[0] Off	All set-ups		TRUE	-	Uint8
9-72	ProfibusDriveReset	[0] No action	1 set-up		FALSE	-	Uint8
9-80	Defined Parameters (1)	0 N/A	All set-ups		FALSE	0	Uint16
9-81	Defined Parameters (2)	0 N/A	All set-ups		FALSE	0	Uint16
9-82	Defined Parameters (3)	0 N/A	All set-ups		FALSE	0	Uint16
9-83	Defined Parameters (4)	0 N/A	All set-ups		FALSE	0	Uint16
9-84	Defined Parameters (5)	0 N/A	All set-ups		FALSE	0	Uint16
9-90	Changed Parameters (1)	0 N/A	All set-ups		FALSE	0	Uint16
9-91	Changed Parameters (2)	0 N/A	All set-ups		FALSE	0	Uint16
9-92	Changed Parameters (3)	0 N/A	All set-ups		FALSE	0	Uint16
9-93	Changed Parameters (4)	0 N/A	All set-ups		FALSE	0	Uint16
9-94	Changed parameters (5)	0 N/A	All set-ups		FALSE	0	Uint16
9-99	Profibus Revision Counter	0 N/A	All set-ups		TRUE	0	Uint16

#### 4.4.11 10- \* \* CAN Fieldbus

Par. No. #	Parameter description	Default value	4-set-up	FC 302 only	Change during operation	Conversion index	Type
<b>10-0* Common Settings</b>							
10-00	CAN Protocol	null	2 set-ups		FALSE	-	Ujnt8
10-01	Baud Rate Select	null	2 set-ups		TRUE	-	Ujnt8
10-02	MAC ID	SR	2 set-ups		TRUE	0	Ujnt8
10-05	Readout Transmit Error Counter	0 N/A	All set-ups		TRUE	0	Ujnt8
10-06	Readout Receive Error Counter	0 N/A	All set-ups		TRUE	0	Ujnt8
10-07	Readout Bus Off Counter	0 N/A	All set-ups		TRUE	0	Ujnt8
<b>10-1* DeviceNet</b>							
10-10	Process Data Type Selection	null	All set-ups		TRUE	-	Ujnt8
10-11	Process Data Config Write	SR	All set-ups		TRUE	-	Ujnt16
10-12	Process Data Config Read	SR	All set-ups		TRUE	-	Ujnt16
10-13	Warning Parameter	0 N/A	All set-ups		TRUE	0	Ujnt16
10-14	Net Reference	[0] Off	2 set-ups		TRUE	-	Ujnt8
10-15	Net Control	[0] Off	2 set-ups		TRUE	-	Ujnt8
<b>10-2* COS Filters</b>							
10-20	COS Filter 1	0 N/A	All set-ups		FALSE	0	Ujnt16
10-21	COS Filter 2	0 N/A	All set-ups		FALSE	0	Ujnt16
10-22	COS Filter 3	0 N/A	All set-ups		FALSE	0	Ujnt16
10-23	COS Filter 4	0 N/A	All set-ups		FALSE	0	Ujnt16
<b>10-3* Parameter Access</b>							
10-30	Array Index	0 N/A	2 set-ups		TRUE	0	Ujnt8
10-31	Store Data Values	[0] Off	All set-ups		TRUE	-	Ujnt8
10-32	Devicenet Revision	SR	All set-ups		TRUE	0	Ujnt16
10-33	Store Always	[0] Off	1 set-up		TRUE	-	Ujnt8
10-34	Devicenet Product Code	SR	1 set-up		TRUE	0	Ujnt16
10-39	Devicenet F Parameters	0 N/A	All set-ups		TRUE	0	Ujnt32
<b>10-5* CANopen</b>							
10-50	Process Data Config Write.	SR	2 set-ups		TRUE	-	Ujnt16
10-51	Process Data Config Read.	SR	2 set-ups		TRUE	-	Ujnt16

### 4.4.12 12- \*\* Ethernet

Par. No. #	Parameter description	Default value	4-set-up	FC 302 only	Change during operation	Conversion index	Type
<b>12-0* IP Settings</b>							
12-00	IP Address Assignment	[0] MANUAL	2 set-ups		TRUE	-	Uimt8
12-01	IP Address	0 N/A	2 set-ups		TRUE	0	OctStr[4]
12-02	Subnet Mask	0 N/A	2 set-ups		TRUE	0	OctStr[4]
12-03	Default Gateway	0 N/A	2 set-ups		TRUE	0	OctStr[4]
12-04	DHCP Server	0 N/A	2 set-ups		TRUE	0	OctStr[4]
12-05	Lease Expires	SR	All set-ups		TRUE	0	TimD
12-06	Name Servers	0 N/A	2 set-ups		TRUE	0	OctStr[4]
12-07	Domain Name	0 N/A	2 set-ups		TRUE	0	VisStr[48]
12-08	Host Name	0 N/A	2 set-ups		TRUE	0	VisStr[48]
12-09	Physical Address	0 N/A	1 set-up		TRUE	0	VisStr[17]
<b>12-1* Ethernet Link Parameters</b>							
12-10	Link Status	[0] No Link	1 set-up		TRUE	-	Uimt8
12-11	Link Duration	SR	All set-ups		TRUE	0	TimD
12-12	Auto Negotiation	[1] On	2 set-ups		TRUE	-	Uimt8
12-13	Link Speed	[0] None	2 set-ups		TRUE	-	Uimt8
12-14	Link Duplex	[1] Full Duplex	2 set-ups		TRUE	-	Uimt8
<b>12-2* Process Data</b>							
12-20	Control Instance	SR	1 set-up		TRUE	0	Uimt8
12-21	Process Data Config Write	SR	All set-ups		TRUE	-	Uimt16
12-22	Process Data Config Read	SR	All set-ups		TRUE	-	Uimt16
12-28	Store Data Values	[0] Off	All set-ups		TRUE	-	Uimt8
12-29	Store Always	[0] Off	1 set-up		TRUE	-	Uimt8
<b>12-3* EtherNet/IP</b>							
12-30	Warning Parameter	0 N/A	All set-ups		TRUE	0	Uimt16
12-31	Net Reference	[0] Off	2 set-ups		TRUE	-	Uimt8
12-32	Net Control	[0] Off	2 set-ups		TRUE	-	Uimt8
12-33	CIP Revision	SR	All set-ups		TRUE	0	Uimt16
12-34	CIP Product Code	SR	1 set-up		TRUE	0	Uimt16
12-35	EDS Parameter	0 N/A	All set-ups		TRUE	0	Uimt32
12-37	COS Inhibit Timer	0 N/A	All set-ups		TRUE	0	Uimt16
12-38	COS Filter	0 N/A	All set-ups		TRUE	0	Uimt16
<b>12-4* Modbus TCP</b>							
12-40	Status Parameter	0 N/A	All set-ups		TRUE	0	Uimt16
12-41	Slave Message Count	0 N/A	All set-ups		TRUE	0	Uimt32
12-42	Slave Exception Message Count	0 N/A	All set-ups		TRUE	0	Uimt32
<b>12-8* Other Ethernet Services</b>							
12-80	FTP Server	[0] Disabled	2 set-ups		TRUE	-	Uimt8
12-81	HTTP Server	[0] Disabled	2 set-ups		TRUE	-	Uimt8
12-82	SMTP Service	[0] Disabled	2 set-ups		TRUE	-	Uimt8
12-89	Transparent Socket Channel Port	4000 N/A	2 set-ups		TRUE	0	Uimt16
<b>12-9* Advanced Ethernet Services</b>							
12-90	Cable Diagnostic	[0] Disabled	2 set-ups		TRUE	-	Uimt8
12-91	MDI-X	[1] Enabled	2 set-ups		TRUE	-	Uimt8
12-92	IGMP Snooping	[1] Enabled	2 set-ups		TRUE	-	Uimt8
12-93	Cable Error Length	0 N/A	1 set-up		TRUE	0	Uimt16
12-94	Broadcast Storm Protection	-1 %	2 set-ups		TRUE	0	Int8
12-95	Broadcast Storm Filter	[0] Broadcast only	2 set-ups		TRUE	-	Uimt8
12-98	Interface Counters	4000 N/A	All set-ups		TRUE	0	Uimt16
12-99	Media Counters	0 N/A	All set-ups		TRUE	0	Uimt16

**4.4.13 13- \* \* Smart Logic**

Par. No. #	Parameter description	Default value	4-set-up	FC 302 only	Change during operation	Conversion index	Type
<b>13-0* SLC Settings</b>							
13-00	SL Controller Mode	null	2 set-ups		TRUE	-	Ujnt8
13-01	Start Event	null	2 set-ups		TRUE	-	Ujnt8
13-02	Stop Event	null	2 set-ups		TRUE	-	Ujnt8
13-03	Reset SLC	[0] Do not reset SLC	All set-ups		TRUE	-	Ujnt8
<b>13-1* Comparators</b>							
13-10	Comparator Operand	null	2 set-ups		TRUE	-	Ujnt8
13-11	Comparator Operator	null	2 set-ups		TRUE	-	Ujnt8
13-12	Comparator Value	SR	2 set-ups		TRUE	-3	Int32
<b>13-2* Timers</b>							
13-20	SL Controller Timer	SR	1 set-up		TRUE	-3	TimD
<b>13-4* Logic Rules</b>							
13-40	Logic Rule Boolean 1	null	2 set-ups		TRUE	-	Ujnt8
13-41	Logic Rule Operator 1	null	2 set-ups		TRUE	-	Ujnt8
13-42	Logic Rule Boolean 2	null	2 set-ups		TRUE	-	Ujnt8
13-43	Logic Rule Operator 2	null	2 set-ups		TRUE	-	Ujnt8
13-44	Logic Rule Boolean 3	null	2 set-ups		TRUE	-	Ujnt8
<b>13-5* States</b>							
13-51	SL Controller Event	null	2 set-ups		TRUE	-	Ujnt8
13-52	SL Controller Action	null	2 set-ups		TRUE	-	Ujnt8

### 4.4.14 14- \*\* Special Functions

Par. No. #	Parameter description	Default value	4-set-up	FC 302 only	Change during operation	Conversion index	Type
<b>14-0* Inverter Switching</b>							
14-00	Switching Pattern	null	All set-ups		TRUE	-	Ujnt8
14-01	Switching Frequency	null	All set-ups		TRUE	-	Ujnt8
14-03	Overmodulation	[1] On	All set-ups		FALSE	-	Ujnt8
14-04	PWM Random	[0] Off	All set-ups		TRUE	-	Ujnt8
<b>14-1* Mains On/Off</b>							
14-10	Mains Failure	[0] No function	All set-ups		FALSE	-	Ujnt8
14-11	Mains Voltage at Mains Fault	SR	All set-ups		TRUE	0	Ujnt16
14-12	Function at Mains Imbalance	[0] Trip	All set-ups		TRUE	-	Ujnt8
14-13	Mains Failure Step Factor	1.0 N/A	All set-ups		TRUE	-1	Ujnt8
<b>14-2* Trip Reset</b>							
14-20	Reset Mode	[0] Manual reset	All set-ups		TRUE	-	Ujnt8
14-21	Automatic Restart Time	10 s	All set-ups		TRUE	0	Ujnt16
14-22	Operation Mode	[0] Normal operation	All set-ups		TRUE	-	Ujnt8
14-23	Typecode Setting	null	2 set-ups		FALSE	-	Ujnt8
14-24	Trip Delay at Current Limit	60 s	All set-ups		TRUE	0	Ujnt8
14-25	Trip Delay at Torque Limit	60 s	All set-ups		TRUE	0	Ujnt8
14-26	Trip Delay at Inverter Fault	SR	All set-ups		TRUE	0	Ujnt8
14-28	Production Settings	[0] No action	All set-ups		TRUE	-	Ujnt8
14-29	Service Code	0 N/A	All set-ups		TRUE	0	Int32
<b>14-3* Current Limit CtrI.</b>							
14-30	Current Lim CtrI, Proportional Gain	100 %	All set-ups		FALSE	0	Ujnt16
14-31	Current Lim CtrI, Integration Time	0.020 s	All set-ups		FALSE	-3	Ujnt16
14-32	Current Lim CtrI, Filter Time	1.0 ms	All set-ups		TRUE	-4	Ujnt16
14-35	Stall Protection	[1] Enabled	All set-ups		FALSE	-	Ujnt8
<b>14-4* Energy Optimising</b>							
14-40	VT Level	66 %	All set-ups		FALSE	0	Ujnt8
14-41	AEO Minimum Magnetisation	SR	All set-ups		TRUE	0	Ujnt8
14-42	Minimum AEO Frequency	10 Hz	All set-ups		TRUE	0	Ujnt8
14-43	Motor Cosphi	SR	All set-ups		TRUE	-2	Ujnt16
<b>14-5* Environment</b>							
14-50	RFI Filter	[1] On	1 set-up	x	FALSE	-	Ujnt8
14-51	DC Link Compensation	[1] On	1 set-up		TRUE	-	Ujnt8
14-52	Fan Control	[0] Auto	All set-ups		TRUE	-	Ujnt8
14-53	Fan Monitor	[1] Warning	All set-ups		TRUE	-	Ujnt8
14-55	Output Filter	[0] No Filter	All set-ups		FALSE	-	Ujnt8
14-56	Capacitance Output Filter	2.0 uF	All set-ups		FALSE	-7	Ujnt16
14-57	Inductance Output Filter	7.000 mH	All set-ups		FALSE	-6	Ujnt16
14-59	Actual Number of Inverter Units	SR	1 set-up	x	FALSE	0	Ujnt8
<b>14-7* Compatibility</b>							
14-72	VLT Alarm Word	0 N/A	All set-ups		FALSE	0	Ujnt32
14-73	VLT Warning Word	0 N/A	All set-ups		FALSE	0	Ujnt32
14-74	VLT Ext. Status Word	0 N/A	All set-ups		FALSE	0	Ujnt32
<b>14-8* Options</b>							
14-80	Option Supplied by External 24VDC	[1] Yes	2 set-ups		FALSE	-	Ujnt8
<b>14-9* Fault Settings</b>							
14-90	Fault Level	null	1 set-up		TRUE	-	Ujnt8

**4.4.15 15- \* \* Drive Information**

Par. No. #	Parameter description	Default value	4-set-up	FC 302 only	Change during operation	Conversion index	Type
<b>15-0* Operating Data</b>							
15-00	Operating Hours	0 h	All set-ups		FALSE	74	Uimt32
15-01	Running Hours	0 h	All set-ups		FALSE	74	Uimt32
15-02	kWh Counter	0 kWh	All set-ups		FALSE	75	Uimt32
15-03	Power Up's	0 N/A	All set-ups		FALSE	0	Uimt32
15-04	Over Temp's	0 N/A	All set-ups		FALSE	0	Uimt16
15-05	Over Volt's	0 N/A	All set-ups		FALSE	0	Uimt16
15-06	Reset kWh Counter	[0] Do not reset	All set-ups		TRUE	-	Uimt8
15-07	Reset Running Hours Counter	[0] Do not reset	All set-ups		TRUE	-	Uimt8
<b>15-1* Data Log Settings</b>							
15-10	Logging Source	0	2 set-ups		TRUE	-	Uimt16
15-11	Logging Interval	SR	2 set-ups		TRUE	-3	TimD
15-12	Trigger Event	[0] False	1 set-up		TRUE	-	Uimt8
15-13	Logging Mode	[0] Log always	2 set-ups		TRUE	-	Uimt8
15-14	Samples Before Trigger	50 N/A	2 set-ups		TRUE	0	Uimt8
<b>15-2* Historic Log</b>							
15-20	Historic Log: Event	0 N/A	All set-ups		FALSE	0	Uimt8
15-21	Historic Log: Value	0 N/A	All set-ups		FALSE	0	Uimt32
15-22	Historic Log: Time	0 ms	All set-ups		FALSE	-3	Uimt32
<b>15-3* Fault Log</b>							
15-30	Fault Log: Error Code	0 N/A	All set-ups		FALSE	0	Uimt8
15-31	Fault Log: Value	0 N/A	All set-ups		FALSE	0	Int16
15-32	Fault Log: Time	0 s	All set-ups		FALSE	0	Uimt32
<b>15-4* Drive Identification</b>							
15-40	FC Type	0 N/A	All set-ups		FALSE	0	VisStr[6]
15-41	Power Section	0 N/A	All set-ups		FALSE	0	VisStr[20]
15-42	Voltage	0 N/A	All set-ups		FALSE	0	VisStr[20]
15-43	Software Version	0 N/A	All set-ups		FALSE	0	VisStr[15]
15-44	Ordered Typecode String	0 N/A	All set-ups		FALSE	0	VisStr[40]
15-45	Actual Typecode String	0 N/A	All set-ups		FALSE	0	VisStr[40]
15-46	Frequency Converter Ordering No	0 N/A	All set-ups		FALSE	0	VisStr[8]
15-47	Power Card Ordering No	0 N/A	All set-ups		FALSE	0	VisStr[8]
15-48	LCP Id No	0 N/A	All set-ups		FALSE	0	VisStr[8]
15-49	SW ID Control Card	0 N/A	All set-ups		FALSE	0	VisStr[20]
15-50	SW ID Power Card	0 N/A	All set-ups		FALSE	0	VisStr[20]
15-51	Frequency Converter Serial Number	0 N/A	All set-ups		FALSE	0	VisStr[20]
15-53	Power Card Serial Number	0 N/A	All set-ups		FALSE	0	VisStr[19]

Par. No. #	Parameter description	Default value	4-set-up	FC 302 only	Change during operation	Conversion index	Type
<b>15-6* Option Ident</b>							
15-60	Option Mounted	0 N/A	All set-ups		FALSE	0	VisStr[30]
15-61	Option SW Version	0 N/A	All set-ups		FALSE	0	VisStr[20]
15-62	Option Ordering No	0 N/A	All set-ups		FALSE	0	VisStr[8]
15-63	Option Serial No	0 N/A	All set-ups		FALSE	0	VisStr[18]
15-70	Option in Slot A	0 N/A	All set-ups		FALSE	0	VisStr[30]
15-71	Slot A Option SW Version	0 N/A	All set-ups		FALSE	0	VisStr[20]
15-72	Option in Slot B	0 N/A	All set-ups		FALSE	0	VisStr[30]
15-73	Slot B Option SW Version	0 N/A	All set-ups		FALSE	0	VisStr[20]
15-74	Option in Slot C0	0 N/A	All set-ups		FALSE	0	VisStr[30]
15-75	Slot C0 Option SW Version	0 N/A	All set-ups		FALSE	0	VisStr[20]
15-76	Option in Slot C1	0 N/A	All set-ups		FALSE	0	VisStr[30]
15-77	Slot C1 Option SW Version	0 N/A	All set-ups		FALSE	0	VisStr[20]
<b>15-9* Parameter Info</b>							
15-92	Defined Parameters	0 N/A	All set-ups		FALSE	0	Uint16
15-93	Modified Parameters	0 N/A	All set-ups		FALSE	0	Uint16
15-98	Drive Identification	0 N/A	All set-ups		FALSE	0	VisStr[40]
15-99	Parameter Metadata	0 N/A	All set-ups		FALSE	0	Uint16

4.4.16 16- \*\* Data Readouts

Par. No. #	Parameter description	Default value	4-set-up	FC 302 only	Change during operation	Conversion index	Type
<b>16-0* General Status</b>							
16-00	Control Word	0 N/A	All set-ups		FALSE	0	V2
16-01	Reference [Unit]	0.000 ReferenceFeedbackUnit	All set-ups		FALSE	-3	Int32
16-02	Reference %	0.0 %	All set-ups		FALSE	-1	Int16
16-03	Status Word	0 N/A	All set-ups		FALSE	0	V2
16-05	Main Actual Value [%]	0.00 %	All set-ups		FALSE	-2	N2
16-09	Custom Readout	0.00 CustomReadoutUnit	All set-ups		FALSE	-2	Int32
<b>16-1* Motor Status</b>							
16-10	Power [kW]	0.00 kW	All set-ups		FALSE	1	Int32
16-11	Power [hp]	0.00 hp	All set-ups		FALSE	-2	Int32
16-12	Motor Voltage	0.0 V	All set-ups		FALSE	-1	Uint16
16-13	Frequency	0.0 Hz	All set-ups		FALSE	-1	Uint16
16-14	Motor Current	0.00 A	All set-ups		FALSE	-2	Int32
16-15	Frequency [%]	0.00 %	All set-ups		FALSE	-2	N2
16-16	Torque [Nm]	0.0 Nm	All set-ups		FALSE	-1	Int16
16-17	Speed [RPM]	0 RPM	All set-ups		FALSE	67	Int32
16-18	Motor Thermal	0 %	All set-ups		FALSE	0	Uint8
16-19	KTY sensor temperature	0 °C	All set-ups		FALSE	100	Int16
16-20	Motor Angle	0 N/A	All set-ups		TRUE	0	Uint16
16-22	Torque [%]	0 %	All set-ups		FALSE	0	Int16
16-25	Torque [Nm] High	0.0 Nm	All set-ups		FALSE	-1	Int32
<b>16-3* Drive Status</b>							
16-30	DC Link Voltage	0 V	All set-ups		FALSE	0	Uint16
16-32	Brake Energy /s	0.000 kW	All set-ups		FALSE	0	Uint32
16-33	Brake Energy /2 min	0.000 kW	All set-ups		FALSE	0	Uint32
16-34	Heatsink Temp.	0 °C	All set-ups		FALSE	100	Uint8
16-35	Inverter Thermal	0 %	All set-ups		FALSE	0	Uint8
16-36	Inv. Nom. Current	SR	All set-ups		FALSE	-2	Uint32
16-37	Inv. Max. Current	SR	All set-ups		FALSE	-2	Uint32
16-38	Sl. Controller State	0 N/A	All set-ups		FALSE	0	Uint8
16-39	Control Card Temp.	0 °C	All set-ups		FALSE	100	Uint8
16-40	Logging Buffer Full	[0] No	All set-ups		TRUE	-	Uint8
16-41	LCP Bottom Statusline	0 N/A	All set-ups		TRUE	0	VisStr[50]
16-49	Current Fault Source	0 N/A	All set-ups	x	TRUE	0	Uint8
<b>16-5* Ref. &amp; Feedsb.</b>							
16-50	External Reference	0.0 N/A	All set-ups		FALSE	-1	Int16
16-51	Pulse Reference	0.0 N/A	All set-ups		FALSE	-1	Int16
16-52	Feedback [Unit]	0.000 ReferenceFeedbackUnit	All set-ups		FALSE	-3	Int32
16-53	Digi Pot Reference	0.00 N/A	All set-ups		FALSE	-2	Int16



Par. No. #	Parameter description	Default value	4-set-up	FC 302 only	Change during operation	Conversion index	Type
<b>16-6* Inputs &amp; Outputs</b>							
16-60	Digital Input	0 N/A	All set-ups		FALSE	0	Uint16
16-61	Terminal 53 Switch Setting	[0] Current	All set-ups		FALSE	-	Uint8
16-62	Analog Input 53	0.000 N/A	All set-ups		FALSE	-3	Int32
16-63	Terminal 54 Switch Setting	[0] Current	All set-ups		FALSE	-	Uint8
16-64	Analog Input 54	0.000 N/A	All set-ups		FALSE	-3	Int32
16-65	Analog Output 42 [mA]	0.000 N/A	All set-ups		FALSE	-3	Int16
16-66	Digital Output [bin]	0 N/A	All set-ups		FALSE	0	Int16
16-67	Freq. Input #29 [Hz]	0 N/A	All set-ups	x	FALSE	0	Int32
16-68	Freq. Input #33 [Hz]	0 N/A	All set-ups		FALSE	0	Int32
16-69	Pulse Output #27 [Hz]	0 N/A	All set-ups		FALSE	0	Int32
16-70	Pulse Output #29 [Hz]	0 N/A	All set-ups	x	FALSE	0	Int32
16-71	Relay Output [bin]	0 N/A	All set-ups		FALSE	0	Int16
16-72	Counter A	0 N/A	All set-ups		TRUE	0	Int32
16-73	Counter B	0 N/A	All set-ups		TRUE	0	Int32
16-74	Prec. Stop Counter	0 N/A	All set-ups		TRUE	0	Uint32
16-75	Analog In X30/11	0.000 N/A	All set-ups		FALSE	-3	Int32
16-76	Analog In X30/12	0.000 N/A	All set-ups		FALSE	-3	Int32
16-77	Analog Out X30/8 [mA]	0.000 N/A	All set-ups		FALSE	-3	Int16
16-78	Analog Out X45/1 [mA]	0.000 N/A	All set-ups		FALSE	-3	Int16
16-79	Analog Out X45/3 [mA]	0.000 N/A	All set-ups		FALSE	-3	Int16
<b>16-8* Fieldbus &amp; FC Port</b>							
16-80	Fieldbus CTW 1	0 N/A	All set-ups		FALSE	0	V2
16-82	Fieldbus REF 1	0 N/A	All set-ups		FALSE	0	N2
16-84	Comm. Option STW	0 N/A	All set-ups		FALSE	0	V2
16-85	FC Port CTW 1	0 N/A	All set-ups		FALSE	0	V2
16-86	FC Port REF 1	0 N/A	All set-ups		FALSE	0	N2
<b>16-9* Diagnosis Readouts</b>							
16-90	Alarm Word	0 N/A	All set-ups		FALSE	0	Uint32
16-91	Alarm Word 2	0 N/A	All set-ups		FALSE	0	Uint32
16-92	Warning Word	0 N/A	All set-ups		FALSE	0	Uint32
16-93	Warning Word 2	0 N/A	All set-ups		FALSE	0	Uint32
16-94	Ext. Status Word	0 N/A	All set-ups		FALSE	0	Uint32

#### 4.4.17 17- \* \* Motor Feedb.Option

Par. No. #	Parameter description	Default value	4-set-up	FC 302 only	Change during operation	Conversion index	Type
<b>17-1* Inc. Enc. Interface</b>							
17-10	Signal Type	[1] RS422 (5V TTL)	All set-ups		FALSE	-	Ujnt8
17-11	Resolution (PPR)	1024 N/A	All set-ups		FALSE	0	Ujnt16
<b>17-2* Abs. Enc. Interface</b>							
17-20	Protocol Selection	[0] None	All set-ups		FALSE	-	Ujnt8
17-21	Resolution (Positions/Rev)	SR	All set-ups		FALSE	0	Ujnt32
17-24	SSI Data Length	13 N/A	All set-ups		FALSE	0	Ujnt8
17-25	Clock Rate	SR	All set-ups		FALSE	3	Ujnt16
17-26	SSI Data Format	[0] Gray code	All set-ups		FALSE	-	Ujnt8
17-34	HIPERFACE Baudrate	[4] 9600	All set-ups		FALSE	-	Ujnt8
<b>17-5* Resolver Interface</b>							
17-50	Poles	2 N/A	1 set-up		FALSE	0	Ujnt8
17-51	Input Voltage	7.0 V	1 set-up		FALSE	-1	Ujnt8
17-52	Input Frequency	10.0 kHz	1 set-up		FALSE	2	Ujnt8
17-53	Transformation Ratio	0.5 N/A	1 set-up		FALSE	-1	Ujnt8
17-59	Resolver Interface	[0] Disabled	All set-ups		FALSE	-	Ujnt8
<b>17-6* Monitoring and App.</b>							
17-60	Feedback Direction	[0] Clockwise	All set-ups		FALSE	-	Ujnt8
17-61	Feedback Signal Monitoring	[1] Warning	All set-ups		TRUE	-	Ujnt8

### 4.4.18 18- \*\* Data Readouts 2

Par. No. #	Parameter description	Default value	4-set-up	FC 302 only	Change during operation	Conversion index	Type
<b>18-90 PID Readouts</b>							
18-90	Process PID Error	0.0 %	All set-ups		FALSE	-1	Int16
18-91	Process PID Output	0.0 %	All set-ups		FALSE	-1	Int16
18-92	Process PID Clamped Output	0.0 %	All set-ups		FALSE	-1	Int16
18-93	Process PID Gain Scaled Output	0.0 %	All set-ups		FALSE	-1	Int16

## 4.4.19 30- \* \* Special Features

Par. No. #	Parameter description	Default value	4-set-up	FC 302 only	Change during operation	Conversion index	Type
<b>30-0*</b>	<b>Wobbler</b>						
30-00	Wobbler Mode	[0] Abs. Freq., Abs. Time	All set-ups		FALSE	-	Uint8
30-01	Wobble Delta Frequency [Hz]	5.0 Hz	All set-ups		TRUE	-1	Uint8
30-02	Wobble Delta Frequency [%]	25 %	All set-ups		TRUE	0	Uint8
30-03	Wobble Delta Freq. Scaling Resource	[0] No function	All set-ups		TRUE	-	Uint8
30-04	Wobble Jump Frequency [Hz]	0.0 Hz	All set-ups		TRUE	-1	Uint8
30-05	Wobble Jump Frequency [%]	0 %	All set-ups		TRUE	0	Uint8
30-06	Wobble Jump Time	SR	All set-ups		TRUE	-3	Uint16
30-07	Wobble Sequence Time	10.0 s	All set-ups		TRUE	-1	Uint16
30-08	Wobble Up/ Down Time	5.0 s	All set-ups		TRUE	-1	Uint16
30-09	Wobble Random Function	[0] Off	All set-ups		TRUE	-	Uint8
30-10	Wobble Ratio	1.0 N/A	All set-ups		TRUE	-1	Uint8
30-11	Wobble Random Ratio Max.	10.0 N/A	All set-ups		TRUE	-1	Uint8
30-12	Wobble Random Ratio Min.	0.1 N/A	All set-ups		TRUE	-1	Uint8
30-19	Wobble Delta Freq. Scaled	0.0 Hz	All set-ups		FALSE	-1	Uint16
<b>30-8* Compatibility (1)</b>							
30-80	d-axis Inductance (Ld)	SR	All set-ups		FALSE	-6	Int32
30-81	Brake Resistor (ohm)	SR	1 set-up		TRUE	-2	Uint32
30-83	Speed PID Proportional Gain	SR	All set-ups		TRUE	-4	Uint32
30-84	Process PID Proportional Gain	0.100 N/A	All set-ups		TRUE	-3	Uint16

### 4.4.20 32- \*\* MCO Basic Settings

Par. No. #	Parameter description	Default value	4-set-up	FC 302 only	Change during operation	Conversion index	Type
<b>32-0* Encoder 2</b>							
32-00	Incremental Signal Type	[1] RS422 (5V TTL)	2 set-ups		TRUE	-	Ujnt8
32-01	Incremental Resolution	1024 N/A	2 set-ups		TRUE	0	Ujnt32
32-02	Absolute Protocol	[0] None	2 set-ups		TRUE	-	Ujnt8
32-03	Absolute Resolution	8192 N/A	2 set-ups		TRUE	0	Ujnt32
32-05	Absolute Encoder Data Length	25 N/A	2 set-ups		TRUE	0	Ujnt8
32-06	Absolute Encoder Clock Frequency	262,000 kHz	2 set-ups		TRUE	0	Ujnt32
32-07	Absolute Encoder Clock Generation	[1] On	2 set-ups		TRUE	-	Ujnt8
32-08	Absolute Encoder Cable Length	0 m	2 set-ups		TRUE	0	Ujnt16
32-09	Encoder Monitoring	[0] Off	2 set-ups		TRUE	-	Ujnt8
32-10	Rotational Direction	[1] No action	2 set-ups		TRUE	-	Ujnt8
32-11	User Unit Denominator	1 N/A	2 set-ups		TRUE	0	Ujnt32
32-12	User Unit Numerator	1 N/A	2 set-ups		TRUE	0	Ujnt32
<b>32-3* Encoder 1</b>							
32-30	Incremental Signal Type	[1] RS422 (5V TTL)	2 set-ups		TRUE	-	Ujnt8
32-31	Incremental Resolution	1024 N/A	2 set-ups		TRUE	0	Ujnt32
32-32	Absolute Protocol	[0] None	2 set-ups		TRUE	-	Ujnt8
32-33	Absolute Resolution	8192 N/A	2 set-ups		TRUE	0	Ujnt32
32-35	Absolute Encoder Data Length	25 N/A	2 set-ups		TRUE	0	Ujnt8
32-36	Absolute Encoder Clock Frequency	262,000 kHz	2 set-ups		TRUE	0	Ujnt32
32-37	Absolute Encoder Clock Generation	[1] On	2 set-ups		TRUE	-	Ujnt8
32-38	Absolute Encoder Cable Length	0 m	2 set-ups		TRUE	0	Ujnt16
32-39	Encoder Monitoring	[0] Off	2 set-ups		TRUE	-	Ujnt8
32-40	Encoder Termination	[1] On	2 set-ups		TRUE	-	Ujnt8
<b>32-5* Feedback Source</b>							
32-50	Source Slave	[2] Encoder 2	2 set-ups		TRUE	-	Ujnt8
32-51	MCO 302 Last Will	[1] Trip	2 set-ups		TRUE	-	Ujnt8
<b>32-6* PID Controller</b>							
32-60	Proportional factor	30 N/A	2 set-ups		TRUE	0	Ujnt32
32-61	Derivative factor	0 N/A	2 set-ups		TRUE	0	Ujnt32
32-62	Integral factor	0 N/A	2 set-ups		TRUE	0	Ujnt32
32-63	Limit Value for Integral Sum	1000 N/A	2 set-ups		TRUE	0	Ujnt16
32-64	PID Bandwidth	1000 N/A	2 set-ups		TRUE	0	Ujnt16
32-65	Velocity Feed-Forward	0 N/A	2 set-ups		TRUE	0	Ujnt32
32-66	Acceleration Feed-Forward	0 N/A	2 set-ups		TRUE	0	Ujnt32
32-67	Max. Tolerated Position Error	20000 N/A	2 set-ups		TRUE	0	Ujnt32
32-68	Reverse Behavior for Slave	[0] Reversing allowed	2 set-ups		TRUE	-	Ujnt8
32-69	Sampling Time for PID Control	1 ms	2 set-ups		TRUE	-3	Ujnt16
32-70	Scan Time for Profile Generator	1 ms	2 set-ups		TRUE	-3	Ujnt8
32-71	Size of the Control Window (Activation)	0 N/A	2 set-ups		TRUE	0	Ujnt32
32-72	Size of the Control Window (Deactiv.)	0 N/A	2 set-ups		TRUE	0	Ujnt32
<b>32-8* Velocity &amp; Accel.</b>							
32-80	Maximum Velocity (Encoder)	1500 RPM	2 set-ups		TRUE	67	Ujnt32
32-81	Shortest Ramp	1.000 s	2 set-ups		TRUE	-3	Ujnt32
32-82	Ramp Type	[0] Linear	2 set-ups		TRUE	-	Ujnt8
32-83	Velocity Resolution	100 N/A	2 set-ups		TRUE	0	Ujnt32
32-84	Default Velocity	50 N/A	2 set-ups		TRUE	0	Ujnt32
32-85	Default Acceleration	50 N/A	2 set-ups		TRUE	0	Ujnt32
<b>32-9* Development</b>							
32-90	Debug Source	[0] Controlcard	2 set-ups		TRUE	-	Ujnt8

## 4.4.21 33- \* \* MCO Adv. Settings

Par. No. #	Parameter description	Default value	4-set-up	FC 302 only	Change during operation	Conversion index	Type
<b>33-0* Home Motion</b>							
33-00	Force HOME	[0] Home not forced	2 set-ups		TRUE	-	Uint8
33-01	Zero Point Offset from Home Pos.	0 N/A	2 set-ups		TRUE	0	Int32
33-02	Ramp for Home Motion	10 N/A	2 set-ups		TRUE	0	Uint32
33-03	Velocity of Home Motion	10 N/A	2 set-ups		TRUE	0	Int32
33-04	Behaviour during HomeMotion	[0] Revers and index	2 set-ups		TRUE	-	Uint8
<b>33-1* Synchronization</b>							
33-10	Synchronization Factor Master (M:S)	1 N/A	2 set-ups		TRUE	0	Int32
33-11	Synchronization Factor Slave (M:S)	1 N/A	2 set-ups		TRUE	0	Int32
33-12	Position Offset for Synchronization	0 N/A	2 set-ups		TRUE	0	Int32
33-13	Accuracy Window for Position Sync.	1000 N/A	2 set-ups		TRUE	0	Int32
33-14	Relative Slave Velocity Limit	0 %	2 set-ups		TRUE	0	Uint8
33-15	Marker Number for Master	1 N/A	2 set-ups		TRUE	0	Uint16
33-16	Marker Number for Slave	1 N/A	2 set-ups		TRUE	0	Uint16
33-17	Master Marker Distance	4096 N/A	2 set-ups		TRUE	0	Uint32
33-18	Slave Marker Distance	4096 N/A	2 set-ups		TRUE	0	Uint32
33-19	Master Marker Type	[0] Encoder Z positive	2 set-ups		TRUE	-	Uint8
33-20	Slave Marker Type	[0] Encoder Z positive	2 set-ups		TRUE	-	Uint8
33-21	Master Marker Tolerance Window	0 N/A	2 set-ups		TRUE	0	Uint32
33-22	Slave Marker Tolerance Window	0 N/A	2 set-ups		TRUE	0	Uint32
33-23	Start Behaviour for Marker Sync	[0] Start Function 1	2 set-ups		TRUE	-	Uint16
33-24	Marker Number for Fault	10 N/A	2 set-ups		TRUE	0	Uint16
33-25	Marker Number for Ready	1 N/A	2 set-ups		TRUE	0	Uint16
33-26	Velocity Filter	0 us	2 set-ups		TRUE	-6	Int32
33-27	Offset Filter Time	0 ms	2 set-ups		TRUE	-3	Uint32
33-28	Marker Filter Configuration	[0] Marker filter 1	2 set-ups		TRUE	-	Uint8
33-29	Filter Time for Marker Filter	0 ms	2 set-ups		TRUE	-3	Int32
33-30	Maximum Marker Correction	0 N/A	2 set-ups		TRUE	0	Uint32
33-31	Synchronisation Type	[0] Standard	2 set-ups		TRUE	-	Uint8
<b>33-4* Limit Handling</b>							
33-40	Behaviour atEnd Limit Switch	[0] Call error handler	2 set-ups		TRUE	-	Uint8
33-41	Negative Software End Limit	-500000 N/A	2 set-ups		TRUE	0	Int32
33-42	Positive Software End Limit	500000 N/A	2 set-ups		TRUE	0	Int32
33-43	Negative Software End Limit Active	[0] Inactive	2 set-ups		TRUE	-	Uint8
33-44	Positive Software End Limit Active	[0] Inactive	2 set-ups		TRUE	-	Uint8
33-45	Time in Target Window	0 ms	2 set-ups		TRUE	-3	Uint8
33-46	Target Window LimitValue	1 N/A	2 set-ups		TRUE	0	Uint16
33-47	Size of Target Window	0 N/A	2 set-ups		TRUE	0	Uint16

Par. No. #	Parameter description	Default value	4-set-up	FC 302 only	Change during operation	Conversion index	Type
<b>33-5* I/O Configuration</b>							
33-50	Terminal X57/1 Digital Input	[0] No function	2 set-ups		TRUE	-	Ujnt8
33-51	Terminal X57/2 Digital Input	[0] No function	2 set-ups		TRUE	-	Ujnt8
33-52	Terminal X57/3 Digital Input	[0] No function	2 set-ups		TRUE	-	Ujnt8
33-53	Terminal X57/4 Digital Input	[0] No function	2 set-ups		TRUE	-	Ujnt8
33-54	Terminal X57/5 Digital Input	[0] No function	2 set-ups		TRUE	-	Ujnt8
33-55	Terminal X57/6 Digital Input	[0] No function	2 set-ups		TRUE	-	Ujnt8
33-56	Terminal X57/7 Digital Input	[0] No function	2 set-ups		TRUE	-	Ujnt8
33-57	Terminal X57/8 Digital Input	[0] No function	2 set-ups		TRUE	-	Ujnt8
33-58	Terminal X57/9 Digital Input	[0] No function	2 set-ups		TRUE	-	Ujnt8
33-59	Terminal X57/10 Digital Input	[0] No function	2 set-ups		TRUE	-	Ujnt8
33-60	Terminal X59/1 and X59/2 Mode	[1] Output	2 set-ups		FALSE	-	Ujnt8
33-61	Terminal X59/1 Digital Input	[0] No function	2 set-ups		TRUE	-	Ujnt8
33-62	Terminal X59/2 Digital Input	[0] No function	2 set-ups		TRUE	-	Ujnt8
33-63	Terminal X59/1 Digital Output	[0] No function	2 set-ups		TRUE	-	Ujnt8
33-64	Terminal X59/2 Digital Output	[0] No function	2 set-ups		TRUE	-	Ujnt8
33-65	Terminal X59/3 Digital Output	[0] No function	2 set-ups		TRUE	-	Ujnt8
33-66	Terminal X59/4 Digital Output	[0] No function	2 set-ups		TRUE	-	Ujnt8
33-67	Terminal X59/5 Digital Output	[0] No function	2 set-ups		TRUE	-	Ujnt8
33-68	Terminal X59/6 Digital Output	[0] No function	2 set-ups		TRUE	-	Ujnt8
33-69	Terminal X59/7 Digital Output	[0] No function	2 set-ups		TRUE	-	Ujnt8
33-70	Terminal X59/8 Digital Output	[0] No function	2 set-ups		TRUE	-	Ujnt8
<b>33-8* Global Parameters</b>							
33-80	Activated Program Number	-1 N/A	2 set-ups		TRUE	0	Int8
33-81	Power-up State	[1] Motor on	2 set-ups		TRUE	-	Ujnt8
33-82	Drive Status Monitoring	[1] On	2 set-ups		TRUE	-	Ujnt8
33-83	Behaviour afterError	[0] Coast	2 set-ups		TRUE	-	Ujnt8
33-84	Behaviour afterEsc.	[0] Controlled stop	2 set-ups		TRUE	-	Ujnt8
33-85	MCO Supplied by External 24VDC	[0] No	2 set-ups		TRUE	-	Ujnt8
33-86	Terminal at alarm	[0] Relay 1	2 set-ups		TRUE	-	Ujnt8
33-87	Terminal state at alarm	[0] Do nothing	2 set-ups		TRUE	-	Ujnt8
33-88	Status word at alarm	0 N/A	2 set-ups		TRUE	0	Ujnt16

**4.4.22 34- \* MCO Data Readouts**

Par. No. #	Parameter description	Default value	4-set-up	FC 302 only	Change during operation	Conversion index	Type
<b>34-0* PCD Write Par.</b>							
34-01	PCD 1 Write to MCO	0 N/A	All set-ups		TRUE	0	Uint16
34-02	PCD 2 Write to MCO	0 N/A	All set-ups		TRUE	0	Uint16
34-03	PCD 3 Write to MCO	0 N/A	All set-ups		TRUE	0	Uint16
34-04	PCD 4 Write to MCO	0 N/A	All set-ups		TRUE	0	Uint16
34-05	PCD 5 Write to MCO	0 N/A	All set-ups		TRUE	0	Uint16
34-06	PCD 6 Write to MCO	0 N/A	All set-ups		TRUE	0	Uint16
34-07	PCD 7 Write to MCO	0 N/A	All set-ups		TRUE	0	Uint16
34-08	PCD 8 Write to MCO	0 N/A	All set-ups		TRUE	0	Uint16
34-09	PCD 9 Write to MCO	0 N/A	All set-ups		TRUE	0	Uint16
34-10	PCD 10 Write to MCO	0 N/A	All set-ups		TRUE	0	Uint16
<b>34-2* PCD Read Par.</b>							
34-21	PCD 1 Read from MCO	0 N/A	All set-ups		TRUE	0	Uint16
34-22	PCD 2 Read from MCO	0 N/A	All set-ups		TRUE	0	Uint16
34-23	PCD 3 Read from MCO	0 N/A	All set-ups		TRUE	0	Uint16
34-24	PCD 4 Read from MCO	0 N/A	All set-ups		TRUE	0	Uint16
34-25	PCD 5 Read from MCO	0 N/A	All set-ups		TRUE	0	Uint16
34-26	PCD 6 Read from MCO	0 N/A	All set-ups		TRUE	0	Uint16
34-27	PCD 7 Read from MCO	0 N/A	All set-ups		TRUE	0	Uint16
34-28	PCD 8 Read from MCO	0 N/A	All set-ups		TRUE	0	Uint16
34-29	PCD 9 Read from MCO	0 N/A	All set-ups		TRUE	0	Uint16
34-30	PCD 10 Read from MCO	0 N/A	All set-ups		TRUE	0	Uint16
<b>34-4* Inputs &amp; Outputs</b>							
34-40	Digital Inputs	0 N/A	All set-ups		TRUE	0	Uint16
34-41	Digital Outputs	0 N/A	All set-ups		TRUE	0	Uint16
<b>34-5* Process Data</b>							
34-50	Actual Position	0 N/A	All set-ups		TRUE	0	Int32
34-51	Commanded Position	0 N/A	All set-ups		TRUE	0	Int32
34-52	Actual Master Position	0 N/A	All set-ups		TRUE	0	Int32
34-53	Slave Index Position	0 N/A	All set-ups		TRUE	0	Int32
34-54	Master Index Position	0 N/A	All set-ups		TRUE	0	Int32
34-55	Curve Position	0 N/A	All set-ups		TRUE	0	Int32
34-56	Track Error	0 N/A	All set-ups		TRUE	0	Int32
34-57	Synchronizing Error	0 N/A	All set-ups		TRUE	0	Int32
34-58	Actual Velocity	0 N/A	All set-ups		TRUE	0	Int32
34-59	Actual Master Velocity	0 N/A	All set-ups		TRUE	0	Int32
34-60	Synchronizing Status	0 N/A	All set-ups		TRUE	0	Int32
34-61	Axis Status	0 N/A	All set-ups		TRUE	0	Int32
34-62	Program Status	0 N/A	All set-ups		TRUE	0	Int32
34-64	MCO Status	0 N/A	All set-ups		TRUE	0	Uint16
34-65	MCO Control	0 N/A	All set-ups		TRUE	0	Uint16
<b>34-7* Diagnosis readouts</b>							
34-70	MCO Alarm Word 1	0 N/A	All set-ups		FALSE	0	Uint32
34-71	MCO Alarm Word 2	0 N/A	All set-ups		FALSE	0	Uint32



## 5 General Specifications

### Mains supply (L1, L2, L3):

Supply voltage	200-240 V ±10%
Supply voltage	FC 301: 380-480 V / FC 302: 380-500 V ±10%
Supply voltage	FC 302: 525-690 V ±10%

### Mains voltage low / mains drop-out:

During low mains voltage or a mains drop-out, the FC continues until the intermediate circuit voltage drops below the minimum stop level, which corresponds typically to 15% below the frequency converter's lowest rated supply voltage. Power-up and full torque cannot be expected at mains voltage lower than 10% below the frequency converter's lowest rated supply voltage.

Supply frequency	50/60 Hz ±5%
Max. imbalance temporary between mains phases	3.0 % of rated supply voltage
True Power Factor ( $\lambda$ )	≥ 0.9 nominal at rated load
Displacement Power Factor ( $\cos \phi$ )	near unity (> 0.98)
Switching on input supply L1, L2, L3 (power-ups) ≤ 7.5 kW	maximum 2 times/min.
Switching on input supply L1, L2, L3 (power-ups) 11-75 kW	maximum 1 time/min.
Switching on input supply L1, L2, L3 (power-ups) ≥ 90 kW	maximum 1 time/2 min.
Environment according to EN60664-1	overvoltage category III/pollution degree 2

The unit is suitable for use on a circuit capable of delivering not more than 100,000 RMS symmetrical Amperes, 240/500/600/ 690 V maximum.

### Motor output (U, V, W):

Output voltage	0 - 100% of supply voltage
Output frequency (0.25-75 kW)	FC 301: 0.2 - 1000 Hz / FC 302: 0 - 1000 Hz
Output frequency (90-1000 kW)	0 - 800* Hz
Output frequency in Flux Mode (FC 302 only)	0 - 300 Hz
Switching on output	Unlimited
Ramp times	0.01 - 3600 sec.

\* Voltage and power dependent

### Torque characteristics:

Starting torque (Constant torque)	maximum 160% for 60 sec.*
Starting torque	maximum 180% up to 0.5 sec.*
Overload torque (Constant torque)	maximum 160% for 60 sec.*
Starting torque (Variable torque)	maximum 110% for 60 sec.*
Overload torque (Variable torque)	maximum 110% for 60 sec.

\*Percentage relates to the nominal torque.

### Digital inputs:

Programmable digital inputs	FC 301: 4 (5) <sup>1)</sup> / FC 302: 4 (6) <sup>1)</sup>
Terminal number	18, 19, 27 <sup>1)</sup> , 29 <sup>1)</sup> , 32, 33,
Logic	PNP or NPN
Voltage level	0 - 24 V DC
Voltage level, logic '0' PNP	< 5 V DC
Voltage level, logic '1' PNP	> 10 V DC
Voltage level, logic '0' NPN <sup>2)</sup>	> 19 V DC
Voltage level, logic '1' NPN <sup>2)</sup>	< 14 V DC
Maximum voltage on input	28 V DC
Pulse frequency range	0 - 110 kHz
(Duty cycle) Min. pulse width	4.5 ms
Input resistance, R <sub>i</sub>	approx. 4 kΩ

### Safe stop Terminal 37<sup>3)</sup> (Terminal 37 is fixed PNP logic):

Voltage level	0 - 24 V DC
Voltage level, logic '0' PNP	< 4 V DC
Voltage level, logic '1' PNP	> 20 V DC
Nominal input current at 24 V	50 mA rms
Nominal input current at 20 V	60 mA rms

5

Input capacitance 400 nF

All digital inputs are galvanically isolated from the supply voltage (PELV) and other high-voltage terminals.

1) Terminals 27 and 29 can also be programmed as output.

2) Except safe stop input Terminal 37.

3) Terminal 37 is only available in FC 302 and FC 301 A1 with Safe Stop. It can only be used as safe stop input. Terminal 37 is suitable for category 3 installations according to EN 954-1 (safe stop according to category 0 EN 60204-1) as required by the EU Machinery Directive 98/37/EC. Terminal 37 and the Safe Stop function are designed in conformance with EN 60204-1, EN 50178, EN 61800-2, EN 61800-3, and EN 954-1. For correct and safe use of the Safe Stop function follow the related information and instructions in the Design Guide.

4) FC 302 only.

Analog inputs:

Number of analog inputs	2
Terminal number	53, 54
Modes	Voltage or current
Mode select	Switch S201 and switch S202
Voltage mode	Switch S201/switch S202 = OFF (U)
Voltage level	FC 301: 0 to + 10/ FC 302: -10 to +10 V (scaleable)
Input resistance, $R_i$	approx. 10 k $\Omega$
Max. voltage	$\pm$ 20 V
Current mode	Switch S201/switch S202 = ON (I)
Current level	0/4 to 20 mA (scaleable)
Input resistance, $R_i$	approx. 200 $\Omega$
Max. current	30 mA
Resolution for analog inputs	10 bit (+ sign)
Accuracy of analog inputs	Max. error 0.5% of full scale
Bandwidth	FC 301: 20 Hz/ FC 302: 100 Hz

The analog inputs are galvanically isolated from the supply voltage (PELV) and other high-voltage terminals.

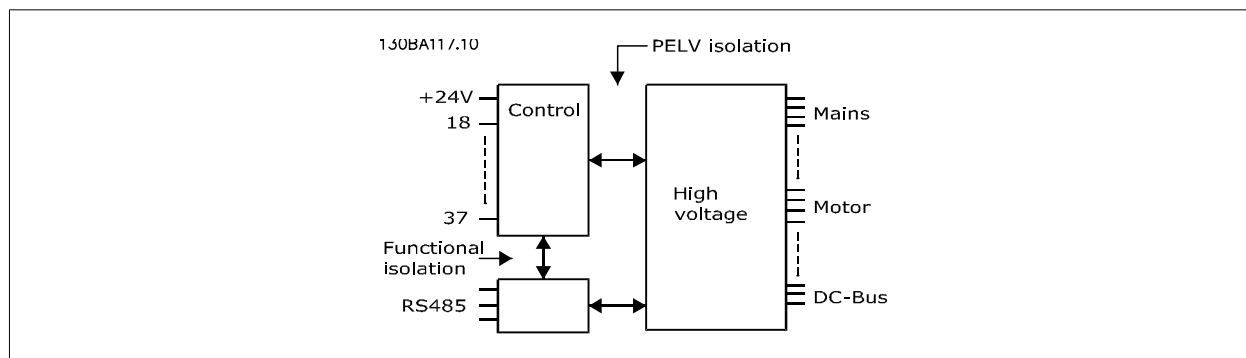

Pulse/encoder inputs:

Programmable pulse/encoder inputs	2/1
Terminal number pulse/encoder	29 <sup>1)</sup> , 33 <sup>2)</sup> / 32 <sup>3)</sup> , 33 <sup>3)</sup>
Max. frequency at terminal 29, 32, 33	110 kHz (Push-pull driven)
Max. frequency at terminal 29, 32, 33	5 kHz (open collector)
Min. frequency at terminal 29, 32, 33	4 Hz
Voltage level	see section on Digital input
Maximum voltage on input	28 V DC
Input resistance, $R_i$	approx. 4 k $\Omega$
Pulse input accuracy (0.1 - 1 kHz)	Max. error: 0.1% of full scale
Encoder input accuracy (1 - 110 kHz)	Max. error: 0.05 % of full scale

The pulse and encoder inputs (terminals 29, 32, 33) are galvanically isolated from the supply voltage (PELV) and other high-voltage terminals.

1) FC 302 only

2) Pulse inputs are 29 and 33

3) Encoder inputs: 32 = A, and 33 = B

Digital output:

Programmable digital/pulse outputs	2
Terminal number	27, 29 <sup>1)</sup>
Voltage level at digital/frequency output	0 - 24 V
Max. output current (sink or source)	40 mA
Max. load at frequency output	1 kΩ
Max. capacitive load at frequency output	10 nF
Minimum output frequency at frequency output	0 Hz
Maximum output frequency at frequency output	32 kHz
Accuracy of frequency output	Max. error: 0.1 % of full scale
Resolution of frequency outputs	12 bit

1) Terminal 27 and 29 can also be programmed as input.

The digital output is galvanically isolated from the supply voltage (PELV) and other high-voltage terminals.

Analog output:

Number of programmable analog outputs	1
Terminal number	42
Current range at analog output	0/4 - 20 mA
Max. load GND - analog output	500 Ω
Accuracy on analog output	Max. error: 0.5 % of full scale
Resolution on analog output	12 bit

The analogue output is galvanically isolated from the supply voltage (PELV) and other high-voltage terminals.

Control card, 24 V DC output:

Terminal number	12, 13
Output voltage	24 V +1, -3 V
Max. load	FC 301: 130 mA/ FC 302: 200 mA

The 24 V DC supply is galvanically isolated from the supply voltage (PELV), but has the same potential as the analog and digital inputs and outputs.

Control card, 10 V DC output:

Terminal number	50
Output voltage	10.5 V ±0.5 V
Max. load	15 mA

The 10 V DC supply is galvanically isolated from the supply voltage (PELV) and other high-voltage terminals.

Control card, RS 485 serial communication:

Terminal number	68 (P,TX+, RX+), 69 (N,TX-, RX-)
Terminal number 61	Common for terminals 68 and 69

The RS 485 serial communication circuit is functionally separated from other central circuits and galvanically isolated from the supply voltage (PELV).

Control card, USB serial communication:

USB standard	1.1 (Full speed)
USB plug	USB type B "device" plug

Connection to PC is carried out via a standard host/device USB cable.

The USB connection is galvanically isolated from the supply voltage (PELV) and other high-voltage terminals.

The USB ground connection is not galvanically isolated from protection earth. Use only an isolated laptop as PC connection to the USB connector on the frequency converter.

Relay outputs:

Programmable relay outputs	FC 301all kW: 1 / FC 302 all kW: 2
Relay 01 Terminal number	1-3 (break), 1-2 (make)
Max. terminal load (AC-1) <sup>1)</sup> on 1-3 (NC), 1-2 (NO) (Resistive load)	240 V AC, 2 A
Max. terminal load (AC-15) <sup>1)</sup> (Inductive load @ cosφ 0.4)	240 V AC, 0.2 A
Max. terminal load (DC-1) <sup>1)</sup> on 1-2 (NO), 1-3 (NC) (Resistive load)	60 V DC, 1A
Max. terminal load (DC-13) <sup>1)</sup> (Inductive load)	24 V DC, 0.1A
Relay 02 (FC 302 only) Terminal number	4-6 (break), 4-5 (make)
Max. terminal load (AC-1) <sup>1)</sup> on 4-5 (NO) (Resistive load) <sup>2)3)</sup> Overvoltage cat. II	400 V AC, 2 A
Max. terminal load (AC-15) <sup>1)</sup> on 4-5 (NO) (Inductive load @ cosφ 0.4)	240 V AC, 0.2 A
Max. terminal load (DC-1) <sup>1)</sup> on 4-5 (NO) (Resistive load)	80 V DC, 2 A
Max. terminal load (DC-13) <sup>1)</sup> on 4-5 (NO) (Inductive load)	24 V DC, 0.1A

Max. terminal load (AC-1) <sup>1)</sup> on 4-6 (NC) (Resistive load)	240 V AC, 2 A
Max. terminal load (AC-15) <sup>1)</sup> on 4-6 (NC) (Inductive load @ cosφ 0.4)	240 V AC, 0.2A
Max. terminal load (DC-1) <sup>1)</sup> on 4-6 (NC) (Resistive load)	50 V DC, 2 A
Max. terminal load (DC-13) <sup>1)</sup> on 4-6 (NC) (Inductive load)	24 V DC, 0.1 A
Min. terminal load on 1-3 (NC), 1-2 (NO), 4-6 (NC), 4-5 (NO)	24 V DC 10 mA, 24 V AC 20 mA
Environment according to EN 60664-1	overvoltage category III/pollution degree 2

1) IEC 60947 part 4 and 5

The relay contacts are galvanically isolated from the rest of the circuit by reinforced isolation (PELV).

2) Overvoltage Category II

3) UL applications 300 V AC 2A

Cable lengths and cross sections for control cables\*:

Max. motor cable length, screened	FC 301: 50 m / FC 301 (A1): 25 m/ FC 302: 150 m
Max. motor cable length, unscreened	FC 301: 75 m / FC 301 (A1): 50 m/ FC 302: 300 m
Maximum cross section to control terminals, flexible/ rigid wire without cable end sleeves	1.5 mm <sup>2</sup> /16 AWG
Maximum cross section to control terminals, flexible wire with cable end sleeves	1 mm <sup>2</sup> /18 AWG
Maximum cross section to control terminals, flexible wire with cable end sleeves with collar	0.5 mm <sup>2</sup> /20 AWG
Minimum cross section to control terminals	0.25 mm <sup>2</sup> / 24 AWG

\* Power cables, see tables in section "Electrical Data" of the Design Guide

For more information, see section *Electrical Data* in the VLT AutomationDrive Design Guide, MG.33.BX.YY.

Control card performance:

Scan interval	FC 301: 5 ms / FC 302: 1 ms
Control characteristics:	
Resolution of output frequency at 0 - 1000 Hz	+/- 0.003 Hz
Repeat accuracy of <i>Precise start/stop</i> (terminals 18, 19)	≤± 0.1 msec
System response time (terminals 18, 19, 27, 29, 32, 33)	≤ 2 ms
Speed control range (open loop)	1:100 of synchronous speed
Speed control range (closed loop)	1:1000 of synchronous speed
Speed accuracy (open loop)	30 - 4000 rpm: error ±8 rpm
Speed accuracy (closed loop), depending on resolution of feedback device	0 - 6000 rpm: error ±0.15 rpm

All control characteristics are based on a 4-pole asynchronous motor

Surroundings:

Enclosure	IP 20 <sup>1)</sup> / Type 1, IP 21 <sup>2)</sup> / Type 1, IP 55/ Type 12, IP 66
Vibration test	1.0 g
Max. relative humidity	5% - 93%(IEC 721-3-3; Class 3K3 (non-condensing) during operation
Aggressive environment (IEC 60068-2-43) H <sub>2</sub> S test	class Kd
Ambient temperature <sup>3)</sup>	Max. 50 °C (24-hour average maximum 45 °C)

1) Only for ≤ 3.7 kW (200 - 240 V), ≤ 7.5 kW (400 - 480/ 500 V)

2) As enclosure kit for ≤ 3.7 kW (200 - 240 V), ≤ 7.5 kW (400 - 480/ 500 V)

3) Derating for high ambient temperature, see special conditions in the Design Guide

Minimum ambient temperature during full-scale operation	0 °C
Minimum ambient temperature at reduced performance	- 10 °C
Temperature during storage/transport	-25 - +65/70 °C
Maximum altitude above sea level without derating	1000 m

Derating for high altitude, see special conditions in the Design Guide

EMC standards, Emission	EN 61800-3, EN 61000-6-3/4, EN 55011 EN 61800-3, EN 61000-6-1/2,
EMC standards, Immunity	EN 61000-4-2, EN 61000-4-3, EN 61000-4-4, EN 61000-4-5, EN 61000-4-6

See section on special conditions in the Design Guide.

Protection and Features:

- Electronic thermal motor protection against overload.
- Temperature monitoring of the heatsink ensures that the frequency converter trips if the temperature reaches a predefined level. An overload temperature cannot be reset until the temperature of the heatsink is below the values stated in the tables on the following pages (Guideline - these temperatures may vary for different power sizes, frame sizes, enclosure ratings etc.).

- The frequency converter is protected against short-circuits on motor terminals U, V, W.
- If a mains phase is missing, the frequency converter trips or issues a warning (depending on the load).
- Monitoring of the intermediate circuit voltage ensures that the frequency converter trips if the intermediate circuit voltage is too low or too high.
- The frequency converter constantly checks for critical levels of internal temperature, load current, high voltage on the intermediate circuit and low motor speeds. As a response to a critical level, the frequency converter can adjust the switching frequency and/ or change the switching pattern in order to ensure the performance of the drive.

6

## 6 Troubleshooting

### 6.1.1 Warnings/Alarm Messages

A warning or an alarm is signalled by the relevant LED on the front of the frequency converter and indicated by a code on the display.

A warning remains active until its cause is no longer present. Under certain circumstances operation of the motor may still be continued. Warning messages may be critical, but are not necessarily so.

In the event of an alarm, the frequency converter will have tripped. Alarms must be reset to restart operation once their cause has been rectified.

**This may be done in three ways:**

1. By using the [RESET] control button on the LCP control panel.
2. Via a digital input with the "Reset" function.
3. Via serial communication/optional fieldbus.



**NB!**

After a manual reset using the [RESET] button on the LCP, the [AUTO ON] button must be pressed to restart the motor.

If an alarm cannot be reset, the reason may be that its cause has not been rectified, or the alarm is trip-locked (see also table on following page).

Alarms that are trip-locked offer additional protection, meaning that the mains supply must be switched off before the alarm can be reset. After being switched back on, the frequency converter is no longer blocked and may be reset as described above once the cause has been rectified.

Alarms that are not trip-locked can also be reset using the automatic reset function in par. 14-20 *Reset Mode* (Warning: automatic wake-up is possible!)

If a warning and alarm is marked against a code in the table on the following page, this means that either a warning occurs before an alarm, or else that you can specify whether it is a warning or an alarm that is to be displayed for a given fault.

This is possible, for instance, in par.1-90 *Motor Thermal Protection*. After an alarm or trip, the motor carries on coasting, and the alarm and warning flash. Once the problem has been rectified, only the alarm continues flashing until the frequency converter is reset.

No.	Description	Warning	Alarm/Trip	Alarm/Trip Lock	Parameter Reference
1	10 Volts low	X			
2	Live zero error	(X)	(X)		Par. 6-01 <i>Live Zero Time-out Function</i>
3	No motor	(X)			Par. 1-80 <i>Function at Stop</i>
4	Mains phase loss	(X)	(X)	(X)	Par. 14-12 <i>Function at Mains Imbalance</i>
5	DC link voltage high	X			
6	DC link voltage low	X			
7	DC over-voltage	X	X		
8	DC under voltage	X	X		
9	Inverter overloaded	X	X		
10	Motor ETR over temperature	(X)	(X)		Par.1-90 <i>Motor Thermal Protection</i>
11	Motor thermistor over temperature	(X)	(X)		Par.1-90 <i>Motor Thermal Protection</i>
12	Torque limit	X	X		
13	Over Current	X	X	X	
14	Earth Fault	X	X	X	
15	Hardware mismatch		X	X	
16	Short Circuit		X	X	
17	Control word time-out	(X)	(X)		Par. 8-04 <i>Control Word Timeout Function</i>
22	Hoist Mech. Brake				
23	Internal Fan Fault	X			
24	External Fan Fault	X			Par. 14-53 <i>Fan Monitor</i>
25	Brake resistor short-circuited	X			
26	Brake resistor power limit	(X)	(X)		Par.2-13 <i>Brake Power Monitoring</i>
27	Brake chopper short-circuited	X	X		
28	Brake check	(X)	(X)		Par.2-15 <i>Brake Check</i>
29	Heatsink temp	X	X	X	
30	Motor phase U missing	(X)	(X)	(X)	Par. 4-58 <i>Missing Motor Phase Function</i>
31	Motor phase V missing	(X)	(X)	(X)	Par. 4-58 <i>Missing Motor Phase Function</i>
32	Motor phase W missing	(X)	(X)	(X)	Par. 4-58 <i>Missing Motor Phase Function</i>
33	Inrush Fault		X	X	
34	Fieldbus communication fault	X	X		
36	Mains failure	X	X		
37	Phase imbalance		X		
38	Internal Fault		X	X	
39	Heatsink sensor		X	X	
40	Overload of Digital Output Terminal 27	(X)			Par.5-00 <i>Digital I/O Mode</i> , par.5-01 <i>Terminal 27 Mode</i>
41	Overload of Digital Output Terminal 29	(X)			Par.5-00 <i>Digital I/O Mode</i> , par.5-02 <i>Terminal 29 Mode</i>
42	Overload of Digital Output On X30/6	(X)			Par. 5-32 <i>Term X30/6 Digi Out (MCB 101)</i>
42	Overload of Digital Output On X30/7	(X)			Par. 5-33 <i>Term X30/7 Digi Out (MCB 101)</i>
46	Pwr. card supply		X	X	
47	24 V supply low	X	X	X	
48	1.8 V supply low		X	X	
49	Speed limit	X			
50	AMA calibration failed		X		
51	AMA check $U_{nom}$ and $I_{nom}$		X		
52	AMA low $I_{nom}$		X		
53	AMA motor too big		X		

Table 6.1: Alarm/Warning code list



No.	Description	Warning	Alarm/Trip	Alarm/Trip Lock	Parameter Reference
54	AMA motor too small		X		
55	AMA parameter out of range		X		
56	AMA interrupted by user		X		
57	AMA time-out		X		
58	AMA internal fault	X	X		
59	Current limit	X			
60	External Interlock	X			
61	Tracking Error	(X)	(X)		Par. 4-30 <i>Motor Feed-back Loss Function</i>
62	Output Frequency at Maximum Limit	X			
63	Mechanical Brake Low		(X)		Par.2-20 <i>Release Brake Current</i>
64	Voltage Limit	X			
65	Control Board Over-temperature	X	X	X	
66	Heat sink Temperature Low	X			
67	Option Configuration has Changed		X		
68	Safe Stop	(X)	(X) <sup>1)</sup>		Par. 5-19 <i>Terminal 37 Safe Stop</i>
69	Pwr. Card Temp		X	X	
70	Illegal FC configuration			X	
71	PTC 1 Safe Stop	X	X <sup>1)</sup>		Par. 5-19 <i>Terminal 37 Safe Stop</i>
72	Dangerous Failure			X <sup>1)</sup>	Par. 5-19 <i>Terminal 37 Safe Stop</i>
73	Safe Stop Auto Restart				
76	Power Unit Setup	X			
77	Reduced power mode	X			Par. 14-59 <i>Actual Number of Inverter Units</i>
78	Tracking Error				
79	Illegal PS config		X	X	
80	Drive Initialized to Default Value		X		
81	CSIV corrupt				
82	CSIV parameter error				
85	Profibus/Profisafe Error				
90	Encoder Loss	(X)	(X)		Par. 17-61 <i>Feedback Signal Monitoring</i>
91	Analogue input 54 wrong settings			X	S202
100-199	See Operating Instructions for MCO 305				
243	Brake IGBT	X	X		
244	Heatsink temp	X	X	X	
245	Heatsink sensor		X	X	
246	Pwr.card supply		X	X	
247	Pwr.card temp		X	X	
248	Illegal PS config		X	X	
250	New spare part			X	Par. 14-23 <i>Typecode Setting</i>
251	New Type Code		X	X	

Table 6.2: Alarm/Warning code list

(X) Dependent on parameter

1) Can not be Auto reset via par. 14-20 *Reset Mode*

A trip is the action when an alarm has appeared. The trip will coast the motor and can be reset by pressing the reset button or make a reset by a digital input (par. group5-1\* [1]). The origin event that caused an alarm cannot damage the frequency converter or cause dangerous conditions. A trip lock is an action when an alarm occurs, which may cause damage to frequency converter or connected parts. A Trip Lock situation can only be reset by a power cycling.

<i>LED indication</i>	
Warning	yellow
Alarm	flashing red
Trip locked	yellow and red

Alarm Word Extended Status Word							
Bit	Hex	Dec	Alarm Word	Alarm Word 2	Warning Word	Warning Word 2	Extended Status Word
0	00000001	1	Brake Check (A28)	ServiceTrip, Read/Write	Brake Check (W28)		Ramping
1	00000002	2	Pwr. Card Temp (A69)	ServiceTrip, (reserved)	Pwr. Card Temp (W69)		AMA Running
2	00000004	4	Earth Fault (A14)	ServiceTrip, Type-code/Sparepart	Earth Fault (W14)		Start CW/CCW
3	00000008	8	Ctrl.Card Temp (A65)	ServiceTrip, (reserved)	Ctrl.Card Temp (W65)		Slow Down
4	00000010	16	Ctrl. Word TO (A17)	ServiceTrip, (reserved)	Ctrl. Word TO (W17)		Catch Up
5	00000020	32	Over Current (A13)		Over Current (W13)		Feedback High
6	00000040	64	Torque Limit (A12)		Torque Limit (W12)		Feedback Low
7	00000080	128	Motor Th Over (A11)		Motor Th Over (W11)		Output Current High
8	00000100	256	Motor ETR Over (A10)		Motor ETR Over (W10)		Output Current Low
9	00000200	512	Inverter Overld. (A9)		Inverter Overld (W9)		Output Freq High
10	00000400	1024	DC under Volt (A8)		DC under Volt (W8)		Output Freq Low
11	00000800	2048	DC over Volt (A7)		DC over Volt (W7)		Brake Check OK
12	00001000	4096	Short Circuit (A16)		DC Voltage Low (W6)		Braking Max
13	00002000	8192	Inrush Fault (A33)		DC Voltage High (W5)		Braking
14	00004000	16384	Mains ph. Loss (A4)		Mains ph. Loss (W4)		Out of Speed Range
15	00008000	32768	AMA Not OK		No Motor (W3)		OVC Active
16	00010000	65536	Live Zero Error (A2)		Live Zero Error (W2)		AC Brake
17	00020000	131072	Internal Fault (A38)	KTY error	10V Low (W1)	KTY Warn	Password Timelock
18	00040000	262144	Brake Overload (A26)	Fans error	Brake Overload (W26)	Fans Warn	Password Protection
19	00080000	524288	U phase Loss (A30)	ECB error	Brake Resistor (W25)	ECB Warn	
20	00100000	1048576	V phase Loss (A31)		Brake IGBT (W27)		
21	00200000	2097152	W phase Loss (A32)		Speed Limit (W49)		
22	00400000	4194304	Fieldbus Fault (A34)		Fieldbus Fault (W34)		Unused
23	00800000	8388608	24 V Supply Low (A47)		24V Supply Low (W47)		Unused
24	01000000	16777216	Mains Failure (A36)		Mains Failure (W36)		Unused
25	02000000	33554432	1.8V Supply Low (A48)		Current Limit (W59)		Unused
26	04000000	67108864	Brake Resistor (A25)		Low Temp (W66)		Unused
27	08000000	134217728	Brake IGBT (A27)		Voltage Limit (W64)		Unused
28	10000000	268435456	Option Change (A67)		Encoder loss (W90)		Unused
29	20000000	536870912	Drive Initial-ized(A80)		Output freq. lim. (W62)		Unused
30	40000000	1073741824	Safe Stop (A68)	PTC 1 Safe Stop (A71)	Safe Stop (W68)	PTC 1 Safe Stop (W71)	Unused
31	80000000	2147483648	Mech. brake low (A63)	Dangerous Failure (A72)	Extended Status Word		Unused

Table 6.3: Description of Alarm Word, Warning Word and Extended Status Word

The alarm words, warning words and extended status words can be read out via serial bus or optional fieldbus for diagnose. See also par. 16-94 *Ext. Status Word*.

**WARNING 1, 10 Volts low:**

The 10 V voltage from terminal 50 on the control card is below 10 V. Remove some of the load from terminal 50, as the 10 V supply is overloaded. Max. 15 mA or minimum 590 Ω.

**WARNING/ALARM 2, Live zero error:**

The signal on terminal 53 or 54 is less than 50% of the value set in par. 6-10 *Terminal 53 Low Voltage*, par. 6-12 *Terminal 53 Low Current*, par. 6-20 *Terminal 54 Low Voltage*, or par. 6-22 *Terminal 54 Low Current* respectively.

**WARNING/ALARM 3, No motor:**

No motor has been connected to the output of the frequency converter.

**WARNING/ALARM 4, Mains phase loss:**

A phase is missing on the supply side, or the mains voltage imbalance is too high.

This message also appears in case of a fault in the input rectifier on the frequency converter.

Check the supply voltage and supply currents to the frequency converter.

**WARNING 5, DC link voltage high:**

The intermediate circuit voltage (DC) is higher than the overvoltage limit of the control system. The frequency converter is still active.

**WARNING 6, DC link voltage low**

The intermediate circuit voltage (DC) is below the undervoltage limit of the control system. The frequency converter is still active.

**WARNING/ALARM 7, DC over voltage:**

If the intermediate circuit voltage exceeds the limit, the frequency converter trips after a time.

**Possible corrections:**

Connect a brake resistor

Extend the ramp time

Activate functions in par.2-10 *Brake Function*

Increase par. 14-26 *Trip Delay at Inverter Fault*

Alarm/warning limits:			
	3 x 200 - 240 V	3 x 380 - 500 V	3 x 525 - 600 V
	[VDC]	[VDC]	[VDC]
Undervoltage	185	373	532
Voltage warning low	205	410	585
Voltage warning high (w/o brake - w/brake)	390/405	810/840	943/965
Overvoltage	410	855	975

The voltages stated are the intermediate circuit voltage of the frequency converter with a tolerance of ± 5 %. The corresponding mains voltage is the intermediate circuit voltage (DC-link) divided by 1.35

**WARNING/ALARM 8, DC under voltage:**

If the intermediate circuit voltage (DC) drops below the "voltage warning low" limit (see table above), the frequency converter checks if 24 V backup supply is connected.

If no 24 V backup supply is connected, the frequency converter trips after a given time depending on the unit.

To check whether the supply voltage matches the frequency converter, see *General Specifications*.

**WARNING/ALARM 9, Inverter overloaded:**

The frequency converter is about to cut out because of an overload (too high current for too long). The counter for electronic, thermal inverter protection gives a warning at 98% and trips at 100%, while giving an alarm. You cannot reset the frequency converter until the counter is below 90%.

The fault is that the frequency converter is overloaded by more than 100% for too long.

**WARNING/ALARM 10, Motor ETR over temperature:**

According to the electronic thermal protection (ETR), the motor is too hot. You can choose if you want the frequency converter to give a warning or an alarm when the counter reaches 100% in par.1-90 *Motor Thermal Protection*. The fault is that the motor is overloaded by more than 100% for too long. Check that the motor par. 1-24 *Motor Current* is set correctly.

**WARNING/ALARM 11, Motor thermistor over temp:**

The thermistor or the thermistor connection is disconnected. You can choose if you want the frequency converter to give a warning or an alarm when the counter reaches 100% in par.1-90 *Motor Thermal Protection*. Check that the thermistor is connected correctly between terminal 53 or 54 (analog voltage input) and terminal 50 (+ 10 V supply), or between terminal 18 or 19 (digital input PNP only) and terminal 50. If aKTY sensor is used, check for correct connection between terminal 54 and 55.

**WARNING/ALARM 12, Torque limit:**

The torque is higher than the value in par. 4-16 *Torque Limit Motor Mode* (in motor operation) or the torque is higher than the value in par. 4-17 *Torque Limit Generator Mode* (in regenerative operation).

**WARNING/ALARM 13, Over Current:**

The inverter peak current limit (approx. 200% of the rated current) is exceeded. The warning will last approx. 8-12 sec., then the frequency converter trips and issues an alarm. Turn off the frequency converter and check if the motor shaft can be turned and if the motor size matches the frequency converter.

If extended mechanical brake control is selected, trip can be reset externally.

**ALARM 14, Earth fault:**

There is a discharge from the output phases to earth, either in the cable between the frequency converter and the motor or in the motor itself. Turn off the frequency converter and remove the earth fault.

**ALARM 15, Incomplete hardware:**

A fitted option is not handled by the present control board (hardware or software).

**ALARM 16, Short-circuit**

There is short-circuiting in the motor or on the motor terminals. Turn off the frequency converter and remove the short-circuit.

**WARNING/ALARM 17, Control word timeout:**

There is no communication to the frequency converter. The warning will only be active when par. 8-04 *Control Word Timeout Function* is NOT set to OFF.

If par. 8-04 *Control Word Timeout Function* is set to *Stop* and *Trip*, a warning appears and the frequency converter ramps down until it trips, while giving an alarm.

Par. 8-03 *Control Word Timeout Time* could possibly be increased.

**WARNING 23, Internal fan fault:**

The fan warning function is an extra protection function that checks if the fan is running / mounted. The fan warning can be disabled in par. 14-53 *Fan Monitor* (set to [0] Disabled).

**WARNING 24, External fan fault:**

The fan warning function is an extra protection function that checks if the fan is running / mounted. The fan warning can be disabled in par. 14-53 *Fan Monitor* (set to [0] Disabled).

**WARNING 25, Brake resistor short-circuited:**

The brake resistor is monitored during operation. If it short-circuits, the brake function is disconnected and the warning appears. The frequency converter still works, but without the brake function. Turn off the frequency converter and replace the brake resistor (see par.2-15 *Brake Check*).

**ALARM/WARNING 26, Brake resistor power limit:**

The power transmitted to the brake resistor is calculated as a percentage, as a mean value over the last 120 s, on the basis of the resistance value of the brake resistor (par.2-11 *Brake Resistor (ohm)*) and the intermediate circuit voltage. The warning is active when the dissipated braking power is higher than 90%. If *Trip[2]* has been selected in par.2-13 *Brake Power Monitoring*, the frequency converter cuts out and issues this alarm, when the dissipated braking power is higher than 100%.

**ALARM/ WARNING 27, Brake chopper fault:**

The brake transistor is monitored during operation and if it short-circuits, the brake function disconnects and the warning comes up. The frequency converter is still able to run, but since the brake transistor has short-circuited, substantial power is transmitted to the brake resistor, even if it is inactive.

Turn off the frequency converter and remove the brake resistor. This alarm/ warning could also occur should the brake resistor overheat. Terminal 104 to 106 are available as brake resistor. Klixon inputs, see section Brake Resistor Temperature Switch.

Warning: There is a risk of substantial power being transmitted to the brake resistor if the brake transistor is short-circuited.

**ALARM/WARNING 28, Brake check failed:**

Brake resistor fault: the brake resistor is not connected/working.

**ALARM 29, Drive over temperature:**

If the enclosure is IP 20 or IP 21/Type 1, the cut-out temperature of the heat-sink is 95 °C ±5 °C. The temperature fault cannot be reset, until the temperature of the heatsink is below 70 °C ±5 °C.

**The fault could be:**

- Ambient temperature too high
- Too long motor cable

**ALARM 30, Motor phase U missing:**

Motor phase U between the frequency converter and the the motor is missing.

Turn off the frequency converter and check motor phase U.

**ALARM 31, Motor phase V missing:**

Motor phase V between the frequency converter and the motor is missing.

Turn off the frequency converter and check motor phase V.

**ALARM 32, Motor phase W missing:**

Motor phase W between the frequency converter and the motor is missing.

Turn off the frequency converter and check motor phase W.

**ALARM 33, Inrush fault:**

Too many power ups have occurred within a short time period. See the chapter *General Specifications* for the allowed number of power ups within one minute.

**WARNING/ALARM 34, Fieldbus communication fault:**

The fieldbus on the communication option card is not working correctly. Please check parameters associated with the module and make sure module is properly inserted in Slot A of the drive. Check the wiring for fieldbus.

**WARNING/ALARM 36, Mains failure:**

This warning/alarm is only active if the supply voltage to the frequency converter is lost and par. 14-10 *Mains Failure* is NOT set to OFF. Possible correction: check the fuses to the frequency converter

**ALARM 37, Phase imbalance:**

There is a current imbalance between the power units

**ALARM 38, Internal fault:**

By this alarm it may be necessary to contact your Danfoss supplier. Some typical alarm messages:

0	The serial port cannot be initialized. Serious hardware failure
256	The power EEPROM data is defect or too old
512	The control board EEPROM data is defect or too old
513	Communication time out Reading EEPROM data
514	Communication time out Reading EEPROM data
515	The Application Orientated Control cannot recognize the EEPROM data
516	Cannot write write to the EEPROM because a write command is on progress
517	The write command is under time out
518	Failure in the EEPROM
519	Missing or invalid BarCode data in EEPROM 1024 – 1279 CAN telegram cannot be sent. (1027 indicate a possible hardware failure)
1281	Digital Signal Processor flash time-out
1282	Power micro software version mismatch
1283	Power EEPROM data version mismatch
1284	Cannot read Digital Signal Processor software version
1299	Option SW in slot A is too old
1300	Option SW in slot B is too old
1311	Option SW in slot C0 is too old

1312	Option SW in slot C1 is too old
1315	Option SW in slot A is not supported (not allowed)
1316	Option SW in slot B is not supported (not allowed)
1317	Option SW in slot C0 is not supported (not allowed)
1318	Option SW in slot C1 is not supported (not allowed)
1536	An exception in the Application Orientated Control is registered. Debug information written in LCP
1792	DSP watchdog is active. Debugging of power part data Motor Orientated Control data not transferred correctly
2049	Power data restarted
2315	Missing SW version from power unit
2816	Stack overflow Control board module
2817	Scheduler slow tasks
2818	Fast tasks
2819	Parameter thread
2820	LCP stack overflow
2821	Serial port overflow
2822	USB port overflow
3072-	Parameter value is outside its limits. Perform a initialization. Parameter number causing the alarm: Subtract the code from 3072. Ex Error code 3238: 3238-3072 = 166 is outside the limit
5122	
5123	Option in slot A: Hardware incompatible with Control board hardware
5124	Option in slot B: Hardware incompatible with Control board hardware
5125	Option in slot C0: Hardware incompatible with Control board hardware
5126	Option in slot C1: Hardware incompatible with Control board hardware
5376-	Out of memory
6231	

**WARNING 40, Overload of Digital Output Terminal 27**

Check the load connected to terminal 27 or remove short-circuit connection. Check par.5-00 *Digital I/O Mode* and par.5-01 *Terminal 27 Mode*.

**WARNING 41, Overload of Digital Output Terminal 29:**

Check the load connected to terminal 29 or remove short-circuit connection. Check par.5-00 *Digital I/O Mode* and par.5-02 *Terminal 29 Mode*.

**WARNING 42, Overload of Digital Output On X30/6 :**

Check the load connected to X30/6 or remove short-circuit connection. Check par. 5-32 *Term X30/6 Digi Out (MCB 101)*.

**WARNING 42, Overload of Digital Output On X30/7 :**

Check the load connected to X30/7 or remove short-circuit connection. Check par. 5-33 *Term X30/7 Digi Out (MCB 101)*.

**WARNING 47, 24 V supply low:**

The external 24 V DC backup power supply may be overloaded, otherwise Contact your Danfoss supplier.

**WARNING 48, 1.8 V supply low:**

Contact your Danfoss supplier.

**WARNING 49, Speed limit:**

The speed is not within the specified range in par. 4-11 *Motor Speed Low Limit [RPM]* and par. 4-13 *Motor Speed High Limit [RPM]*.

**ALARM 50, AMA calibration failed:**

Contact your Danfoss supplier.

**ALARM 51, AMA check Unom and Inom:**

The setting of motor voltage, motor current, and motor power is presumably wrong. Check the settings.

**ALARM 52, AMA low Inom:**

The motor current is too low. Check the settings.

**ALARM 53, AMA motor too big:**

The motor is too big for the AMA to be carried out.

**ALARM 54, AMA motor too small:**

The motor is too small for the AMA to be carried out.

**ALARM 55, AMA par. out of range:**

The motor parameter values found from the motor are outside acceptable range.

**ALARM 56, AMA interrupted by user:**

The AMA has been interrupted by the user.

**ALARM 57, AMA timeout:**

Try to start the AMA again a number of times, until the AMA is carried out. Please note that repeated runs may heat the motor to a level where the resistance Rs and Rr are increased. In most cases, however, this is not critical.

**ALARM 58, AMA internal fault:**

Contact your Danfoss supplier.

**WARNING 59, Current limit:**

The current is higher than the value in par. 4-18 *Current Limit*.

**ALARM/WARNING 61, Tracking Error:**

An error between calculated speed and speed measurement from feedback device. The function Warning/Alarm/Disabling setting is in par. 4-30 *Motor Feedback Loss Function*. Accepted error setting in par. 4-31 *Motor Feedback Speed Error* and the allowed time the error occur setting in par. 4-32 *Motor Feedback Loss Timeout*. During a commissioning procedure the function may be effective.

**WARNING 62, Output Frequency at Maximum Limit:**

The output frequency is higher than the value set in par. 4-19 *Max Output Frequency*. This is a warning in VVC+ mode and an alarm (trip) in Flux mode.

**ALARM 63, Mechanical Brake Low:**

The actual motor current has not exceeded the "release brake" current within the "Start delay" time window.

**WARNING 64, Voltage Limit:**

The load and speed combination demands a motor voltage higher than the actual DC link voltage.

**WARNING/ALARM/TRIP 65, Control Card Over Temperature:**

Control card over temperature: The cut-out temperature of the control card is 80° C.

**WARNING 66, Heatsink Temperature Low:**

The heat sink temperature is measured as 0° C. This could indicate that the temperature sensor is defect and thus the fan speed is increased to the maximum in case the power part or control card is very hot.

**ALARM 67, Option Configuration has Changed:**

One or more options has either been added or removed since the last power down.

**ALARM 68, Safe Stop:**

Safe Stop has been activated. To resume normal operation, apply 24 V DC to T-37. Press reset button on LCP.

**WARNING 68, Safe Stop:**

Safe Stop has been activated. Normal operation is resumed when Safe Stop is disabled. Warning: Automatic Restart!

**ALARM 70, Illegal FC Configuration:**

Actual combination of control board and power board is illegal.

**ALARM 71, PTC 1 Safe Stop:**

Safe Stop has been activated from the MCB 112 PTC Thermistor Card (motor too warm). Normal operation can be resumed when the MCB 112 applies 24 V DC to T-37 again (when the motor temperature reaches an acceptable level) and when the Digital Input from the MCB 112 is deac-

tivated. When that happens, a reset signal must be is be sent (via Bus, Digital I/O, or by pressing [RESET]).

**WARNING 71, PTC 1 Safe Stop:**

Safe Stop has been activated from the MCB 112 PTC Thermistor Card (motor too warm). Normal operation can be resumed when the MCB 112 applies 24 V DC to T-37 again (when the motor temperature reaches an acceptable level) and when the Digital Input from the MCB 112 is deactivated. Warning: Automatic Restart.

**ALARM 72, Dangerous Failure:**

Safe Stop with Trip Lock. The Dangerous Failure Alarm is issued if the combination of safe stop commands is unexpected. This is the case if the MCB 112 VLT PTC Thermistor Card enables X44/ 10 but safe stop is somehow not enabled. Furthermore, if the MCB 112 is the only device using safe stop (specified through selection [4] or [5] in par. 5-19), an unexpected combination is activation of safe stop without the X44/ 10 being activated. The following table summarizes the unexpected combinations that lead to Alarm 72. Note that if X44/ 10 is activated in selection 2 or 3, this signal is ignored! However, the MCB 112 will still be able to activate Safe Stop.

Function	No.	X44/ 10 (DI)	Safe Stop T37
PTC 1 Warning	[4]	+	-
		-	+
PTC 1 Alarm	[5]	+	-
		-	+
PTC 1 & Relay A	[6]	+	-
PTC 1 & Relay W	[7]	+	-
PTC 1 & RelayA/ W	[8]	+	-
PTC 1 & Relay W/A	[9]	+	-

+: activated  
-: Not activated

**ALARM 78, Tracking Error:**

Please contact Danfoss

**ALARM 80, Drive Initialised to Default Value:**

Parameter settings are initialised to default setting after a manual (three-finger) reset.

**ALARM 90, Encoder loss:**

Check the connection to encoder option and eventually replace the MCB 102or MCB 103.

**ALARM 91, Analogue Input 54 Wrong Settings:**

Switch S202 has to be set in position OFF (voltage input) when a KTY sensor is connected to analogue input terminal 54.

**ALARM 250, New Spare Part:**

The power or Switch Mode Power Supply has been exchanged. The frequency converter type code must be restored in the EEPROM. Select the correct type code in par. 14-23 *Typecode Setting* according to the label on unit. Remember to select 'Save to EEPROM' to complete.

**ALARM 251, New Type Code:**

The Frequency Converter has got a new type code.

## Index

### A

Abbreviations	5
Access To Control Terminals	30
Activate Brake Delay 2-23	53
[Activate Brake Speed Hz] 2-22	53
[Activate Brake Speed Rpm] 2-21	53
Alarm Messages	103
Ama	37
Analog Inputs	98
Analog Output	99
Approvals	4
Automatic Motor Adaptation (ama)	37, 45

### B

Brake Check 2-15	52
Brake Control	107
Brake Function 2-10	50
Brake Power Limit (kw) 2-12	51
Brake Power Monitoring 2-13	51
Brake Release Time 2-25	54
Brake Resistor (ohm) 2-11	51

### C

Cable Lengths And Cross Sections	100
Cable Lengths And Cross Sections-continued	100
Catch Up	59
Checklist	15
Communication Option	108
Connection To Mains	21
Control Cables	35
Control Cables	34
Control Card Performance	100
Control Card, +10 V Dc Output	99
Control Card, 24 V Dc Output	99
Control Card, Rs 485 Serial Communication	99
Control Card, Usb Serial Communication	99
Control Characteristics	100
Control Terminals	31
Cooling	48
Cooling Conditions	18

### D

Dc Backup	3
Dc Link	106
Decoupling Plate	24
Default Settings	66
Devicenet	3
Digital I/o Mode 5-00	56
Digital Inputs:	97
Digital Output	98
Disposal Instruction	5

### E

Electrical Installation	31, 34
Electrical Terminals	34
Electronic Terminal Relay	50
Etr	107

### F

Function Relay 5-40	62
Fuses	27

## G

Gain Boost Factor 2-28	54
General Warning	9
Graphical Display	41

## I

Intermediate Circuit	106
Ip21 / Type 1	3

## J

[Jog Speed Hz] 3-11	55
---------------------	----

## K

Kty Sensor	107
------------	-----

## L

Language 0-01	43
Language Package 1	43
Language Package 2	43
Language Package 3	43
Language Package 4	43
Lcp Copy 0-50	47
Leakage Current	9
Leds	41
Local Control Panel	41

## M

Main Reactance	45
Mains Supply (I1, L2, L3)	97
Maximum Reference 3-03	46
Mct 10	3
Mechanical Brake Control	39
Mechanical Dimensions	16
Mechanical Mounting	18
Minimum Reference 3-02	46
Motor Connection	24
Motor Current 1-24	44
Motor Frequency 1-23	44
Motor Name Plate	37
Motor Nominal Speed 1-25	44
Motor Output	97
[Motor Power Kw] 1-20	44
Motor Protection	48, 100
Motor Speed Unit 0-02	47
Motor Thermal Protection	39, 48
Motor Voltage 1-22	44

## N

Name Plate Data	37
Non UI Compliance	27
Numerical Display	41

## O

Operation Mode 14-22	64
Output Performance (u, V, W)	97
Overload Mode 1-04	47

## P

Panel Through Mounting	19
Parallel Connection Of Motors	39

Potentiometer Reference	33
Preset Reference 3-10	54
Profibus	3
Protection	27
Protection And Features	100
Protection Mode	8
Pulse Start/stop	32
Pulse/encoder Inputs	98

## R

Ramp 1 Ramp Down Time 3-42	46
Ramp 1 Ramp Up Time 3-41	46
Reference Resource 1 3-15	55
Reference Resource 2 3-16	55
Reference Resource 3 3-17	56
Relay Outputs	60
Relay Outputs	99
Release Brake Current 2-20	53
Removal Of Knockouts For Extra Cables	20
Repair Work	9
Residual Current Device	9
Rfi Filter 14-50	65

## S

Safe Stop	9
Safety Precautions	7
Screened/armoured	35
Serial Communication	99
Shaft Performance Levels	3
Side-by-side Installation	18
Sine-wave Filter	27
Software Version 15-43	65
Speed Up/down	33
Start/stop	32
Stator Leakage Reactance	45
Status Messages	41
Stop Delay 2-24	53
Surroundings	100
Switches S201, S202, And S801	36
Symbols	4

## T

Terminal 27 Mode 5-01	56
Terminal 29 Mode 5-02	56
Thermistor	48
Thermistor Source 1-93	50
Torque Characteristics 1-03	47, 97
Torque Ramp Time 2-27	54
Torque Ref 2-26	54

## V

Voltage Level	97
Voltage Reference Via A Potentiometer	33

## W

Warnings	103
----------	-----