



Operating Instructions

VLT[®] AutomationDrive FC 300

Safety

⚠ WARNING

HIGH VOLTAGE!

Frequency converters contain high voltage when connected to AC mains input power. Installation, start up, and maintenance should be performed by qualified personnel only. Failure to perform installation, start up, and maintenance by qualified personnel could result in death or serious injury.

High Voltage

Frequency converters are connected to hazardous mains voltages. Extreme care should be taken to protect against shock. Only trained personnel familiar with electronic equipment should install, start, or maintain this equipment.

⚠ WARNING

UNINTENDED START!

When the frequency converter is connected to AC mains, the motor may start at any time. The frequency converter, motor, and any driven equipment must be in operational readiness. Failure to be in operational readiness when the frequency converter is connected to AC mains could result in death, serious injury, equipment, or property damage.

Unintended Start

When the frequency converter is connected to the AC mains, the motor may be started by means of an external switch, a serial bus command, an input reference signal, or a cleared fault condition. Use appropriate cautions to guard against an unintended start.

⚠ WARNING

DISCHARGE TIME!

Frequency converters contain DC link capacitors that can remain charged even when AC mains is disconnected. To avoid electrical hazards, remove AC mains from the frequency converter before doing any service or repair and wait the amount of time specified in *Table 1.1*. Failure to wait the specified time after power has been removed prior to doing service or repair on the unit could result in death or serious injury.

Voltage (V)	Minimum waiting time (minutes)	
	4	15
200 - 240	0.25 - 3.7 kW	5.5 - 37 kW
380 - 480	0.25 - 7.5 kW	11 - 75 kW
525 - 600	0.75 - 7.5 kW	11 - 75 kW
525 - 690	n/a	11 - 75 kW

High voltage may be present even when the warning LEDs are off!

Table 1.1 Discharge Time

Symbols

The following symbols are used in this manual.

⚠ WARNING

Indicates a potentially hazardous situation which, if not avoided, could result in death or serious injury.

⚠ CAUTION

Indicates a potentially hazardous situation which, if not avoided, may result in minor or moderate injury. It may also be used to alert against unsafe practices.

CAUTION

Indicates a situation that may result in equipment or property-damage-only accidents.

NOTE

Indicates highlighted information that should be regarded with attention to avoid mistakes or operate equipment at less than optimal performance.

Approvals



Contents

1 Introduction	4
1.1 Purpose of the Manual	5
1.2 Additional Resources	5
1.3 Product Overview	6
1.4 Internal Frequency Converter Controller Functions	6
1.5 Frame Sizes and Power Ratings	7
2 Installation	8
2.1 Installation Site Check List	8
2.2 Frequency Converter and Motor Pre-installation Check List	8
2.3 Mechanical Installation	8
2.3.1 Cooling	8
2.3.2 Lifting	9
2.3.3 Mounting	9
2.3.4 Tightening Torques	9
2.4 Electrical Installation	10
2.4.1 Requirements	12
2.4.2 Earth (Grounding) Requirements	12
2.4.2.1 Leakage Current (>3,5mA)	13
2.4.2.2 Grounding Using Shielded Cable	13
2.4.3 Motor Connection	13
2.4.4 AC Mains Connection	14
2.4.5 Control Wiring	14
2.4.5.1 Access	14
2.4.5.2 Control Terminal Types	15
2.4.5.3 Wiring to Control Terminals	16
2.4.5.4 Using Screened Control Cables	16
2.4.5.5 Control Terminal Functions	16
2.4.5.6 Jumper Terminals 12 and 27	17
2.4.5.7 Terminal 53 and 54 Switches	17
2.4.5.8 Terminal 37	17
2.4.5.9 Mechanical Brake Control	20
2.4.6 Serial Communication	20
3 Start Up and Functional Testing	21
3.1 Pre-start	21
3.1.1 Safety Inspection	21
3.1.2 Start Up Check List	22
3.2 Applying Power to the Frequency Converter	23
3.3 Basic Operational Programming	23

3.4 Automatic Motor Adaptation	24
3.5 Check Motor Rotation	25
3.6 Check Encoder Rotation	25
3.7 Local-control Test	25
3.8 System Start Up	26
4 User Interface	27
4.1 Local Control Panel	27
4.1.1 LCP Layout	27
4.1.2 Setting LCP Display Values	28
4.1.3 Display Menu Keys	28
4.1.4 Navigation Keys	29
4.1.5 Operation Keys	29
4.2 Back Up and Copying Parameter Settings	29
4.2.1 Uploading Data to the LCP	30
4.2.2 Downloading Data from the LCP	30
4.3 Restoring Default Settings	30
4.3.1 Recommended Initialisation	30
4.3.2 Manual Initialisation	30
5 About Frequency Converter Programming	31
5.1 Introduction	31
5.2 Programming Example	31
5.3 Control Terminal Programming Examples	32
5.4 International/North American Default Parameter Settings	33
5.5 Parameter Menu Structure	34
5.5.1 Main Menu Structure	35
5.6 Remote Programming with MCT 10 Set-up Software	39
6 Application Set-Up Examples	40
6.1 Introduction	40
6.2 Application Examples	40
7 Status Messages	45
7.1 Status Display	45
7.2 Status Message Definitions Table	45
8 Warnings and Alarms	48
8.1 System Monitoring	48
8.2 Warning and Alarm Types	48
8.3 Warning and Alarm Displays	48
8.4 Warning and Alarm Definitions	49

8.4.1 Fault Messages	51
9 Basic Troubleshooting	59
9.1 Start Up and Operation	59
10 Specifications	61
10.1 Power-dependent Specifications	61
10.2 General Technical Data	70
10.3 Fuse Tables	75
10.3.2 CE Compliance	76
10.4 Connection Tightening Torques	83
Index	84

1 Introduction

1

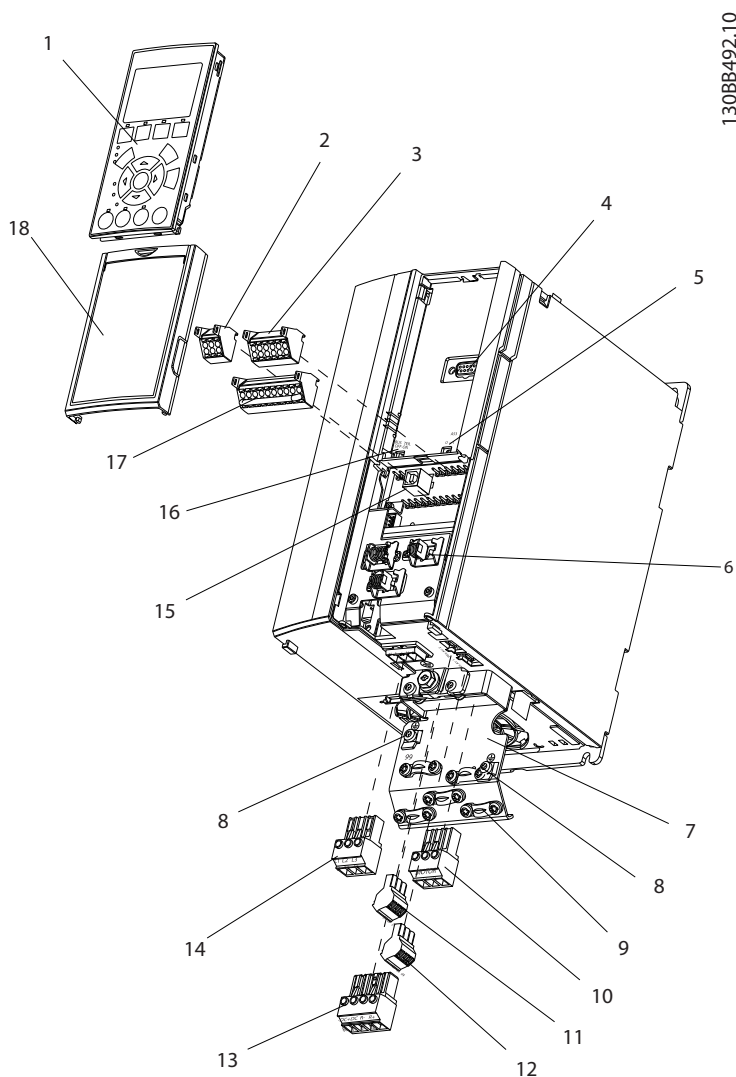

Illustration 1.1 Exploded View A1-A3, IP20

1	LCP	10	Motor output terminals 96 (U), 97 (V), 98 (W)
2	RS-485 serial bus connector (+68, -69)	11	Relay 1 (01, 02, 03)
3	Analog I/O connector	12	Relay 2 (04, 05, 06)
4	LCP input plug	13	Brake (-81, +82) and load sharing (-88, +89) terminals
5	Analog switches (A53), (A54)	14	Mains input terminals 91 (L1), 92 (L2), 93 (L3)
6	Cable strain relief / PE ground	15	USB connector
7	Decoupling plate	16	Serial bus terminal switch
8	Grounding clamp (PE)	17	Digital I/O and 24 V power supply
9	Shielded cable grounding clamp and strain relief	18	Control cable cover plate

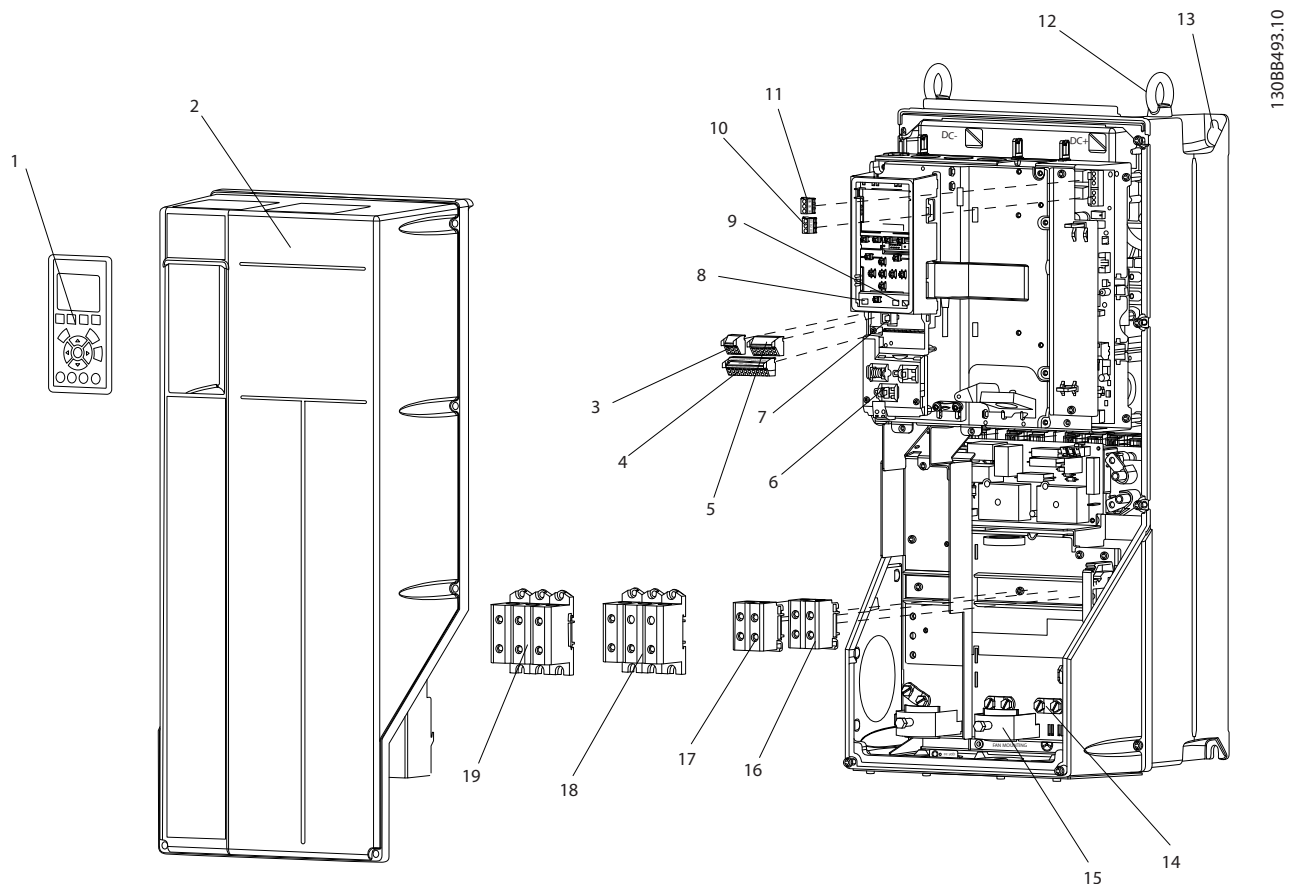

Illustration 1.2 Exploded View B and C Sizes, IP55/66

1	LCP	11	Relay 2 (04, 05, 06)
2	Cover	12	Lifting ring
3	RS-485 serial bus connector	13	Mounting slot
4	Digital I/O and 24 V power supply	14	Grounding clamp (PE)
5	Analog I/O connector	15	Cable strain relief / PE ground
6	Cable strain relief / PE ground	16	Brake terminal (-81, +82)
7	USB connector	17	Load sharing terminal (DC bus) (-88, +89)
8	Serial bus terminal switch	18	Motor output terminals 96 (U), 97 (V), 98 (W)
9	Analog switches (A53), (A54)	19	Mains input terminals 91 (L1), 92 (L2), 93 (L3)
10	Relay 1 (01, 02, 03)		

1.1 Purpose of the Manual

This manual is intended to provide detailed information for the installation and start up of the frequency converter. Chapter 2 *Installation* provides requirements for mechanical and electrical installation, including input, motor, control and serial communications wiring, and control terminal functions. Chapter 3 *Start Up and Functional Testing* provides detailed procedures for start up, basic operational programming, and functional testing. The remaining chapters provide supplementary details. These include user interface, detailed programming, application examples, start-up troubleshooting, and specifications.

1.2 Additional Resources

Other resources are available to understand advanced frequency converter functions and programming.

- The Programming Guide provides greater detail in how to work with parameters and many application examples.
- The Design Guide is intended to provide detailed capabilities and functionality to design motor control systems.

- Supplemental publications and manuals are available from Danfoss. See <http://www.danfoss.com/Products/Literature/Technical+Documentation.htm> for listings.
- Optional equipment is available that may change some of the procedures described. Be sure to see the instructions supplied with those options for specific requirements.

Contact the local Danfoss supplier or go to <http://www.danfoss.com/Products/Literature/Technical+Documentation.htm> for downloads or additional information.

1.3 Product Overview

A frequency converter is an electronic motor controller that converts AC mains input into a variable AC waveform output. The frequency and voltage of the output are regulated to control the motor speed or torque. The frequency converter can vary the speed of the motor in response to system feedback, such as position sensors on a conveyor belt. The frequency converter can also regulate the motor by responding to remote commands from external controllers.

In addition, the frequency converter monitors the system and motor status, issues warnings or alarms for fault conditions, starts and stops the motor, optimizes energy efficiency, and offers many more control, monitoring, and efficiency functions. Operation and monitoring functions are available as status indications to an outside control system or serial communication network.

1.4 Internal Frequency Converter Controller Functions

Below is a block diagram of the frequency converter's internal components. See *Table 1.1* for their functions.

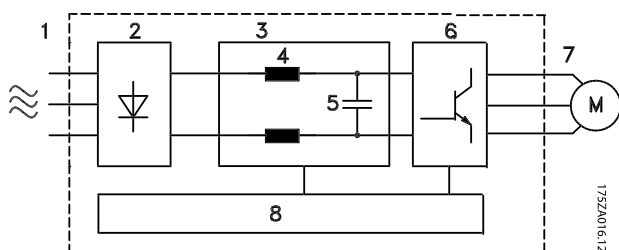

Illustration 1.3 Frequency Converter Block Diagram

Area	Title	Functions
1	Mains input	<ul style="list-style-type: none"> • Three-phase AC mains power supply to the frequency converter
2	Rectifier	<ul style="list-style-type: none"> • The rectifier bridge converts the AC input to DC current to supply inverter power
3	DC bus	<ul style="list-style-type: none"> • The frequency converter's intermediate DC-bus circuit handles the DC current
4	DC reactors	<ul style="list-style-type: none"> • Filter the intermediate DC circuit voltage • Provide line transient protection • Reduce RMS current • Raise the power factor reflected back to the line • Reduce harmonics on the AC input
5	Capacitor bank	<ul style="list-style-type: none"> • Stores the DC power • Provides ride-through protection for short power losses
6	Inverter	<ul style="list-style-type: none"> • Converts the DC into a controlled PWM AC waveform for a controlled variable output to the motor
7	Output to motor	<ul style="list-style-type: none"> • Regulated three-phase output power to the motor
8	Control circuitry	<ul style="list-style-type: none"> • Input power, internal processing, output, and motor current are monitored to provide efficient operation and control • User interface and external commands are monitored and performed • Status output and control can be provided

Table 1.1 Frequency Converter Internal Components

1.5 Frame Sizes and Power Ratings

Volts	Frame size (kW)												
	A1	A2	A3	A4	A5	B1	B2	B3	B4	C1	C2	C3	C4
200-240	0.25-1.5	0.25-2.2	3.0-3.7	0.25-2.2	0.25-3.7	5.5-7.5	11	5.5-7.5	11-15	15-22	30-37	18.5-22	30-37
380-480	0.37-1.5	0.37-4.0	5.5-7.5	0.37-4.0	0.37-7.5	11-15	18.5-22	11-15	18.5-30	30-45	55-75	37-45	55-75
525-600	N/A	N/A	0.75-7.5	N/A	0.75-7.5	11-15	18.5-22	11-15	18.5-30	30-45	55-90	37-45	55-90
525-690	N/A	N/A	N/A	N/A	N/A	N/A	11-22	N/A	N/A	N/A	30-75	N/A	N/A

Table 1.2 Frames Sizes and Power Ratings

1

2 Installation

2

2.1 Installation Site Check List

- The frequency converter relies on the ambient air for cooling. Observe the limitations on ambient air temperature for optimal operation
- Ensure that the installation location has sufficient support strength to mount the frequency converter
- Keep the frequency converter interior free from dust and dirt. Ensure that the components stay as clean as possible. In construction areas, provide a protective covering. Optional IP55 (NEMA 12) or IP66 (NEMA 4) enclosures may be necessary.
- Keep the manual, drawings, and diagrams accessible for detailed installation and operation instructions. It is important that the manual is available for equipment operators.
- Locate equipment as near to the motor as possible. Keep motor cables as short as possible. Check the motor characteristics for actual tolerances. Do not exceed
 - 300m (1000ft) for unshielded motor leads
 - 150m (500ft) for shielded cable.

2.2 Frequency Converter and Motor Pre-installation Check List

- Compare the model number of unit on the nameplate to what was ordered to verify the proper equipment
- Ensure each of the following are rated for same voltage:
 - Mains (power)
 - Frequency converter
 - Motor
- Ensure that frequency converter output current rating is equal to or greater than motor full load current for peak motor performance
 - Motor size and frequency converter power must match for proper overload protection
 - If frequency converter rating is less than motor, full motor output cannot be achieved

2.3 Mechanical Installation

2.3.1 Cooling

- To provide cooling airflow, mount the unit to a solid flat surface or to the optional back plate (see 2.3.3 Mounting)
- Top and bottom clearance for air cooling must be provided. Generally, 100-225mm (4-10in) is required. See *Illustration 2.1* for clearance requirements
- Improper mounting can result in over heating and reduced performance
- Derating for temperatures starting between 40°C (104°F) and 50°C (122°F) and elevation 1000m (3300ft) above sea level must be considered. See the equipment Design Guide for detailed information.

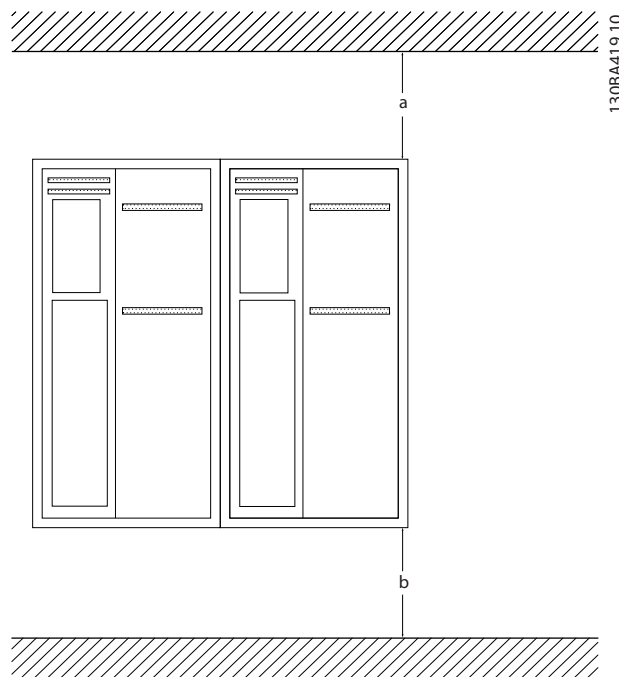

Illustration 2.1 Top and Bottom Cooling Clearance

Enclosure	A1-A5	B1-B4	C1, C3	C2, C4
a/b (mm)	100	200	200	225

Table 2.1 Minimum Airflow Clearance Requirements

2.3.2 Lifting

- Check the weight of the unit to determine a safe lifting method
- Ensure that the lifting device is suitable for the task
- If necessary, plan for a hoist, crane, or forklift with the appropriate rating to move the unit
- For lifting, use hoist rings on the unit, when provided

2.3.3 Mounting

- Mount the unit vertically
- The frequency converter allows side by side installation
- Ensure that the strength of the mounting location will support the unit weight
- Mount the unit to a solid flat surface or to the optional back plate to provide cooling airflow (see *Illustration 2.2* and *Illustration 2.3*)
- Improper mounting can result in over heating and reduced performance
- Use the slotted mounting holes on the unit for wall mounting, when provided

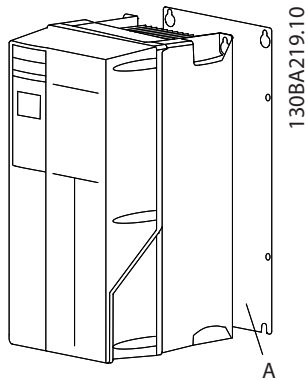

Illustration 2.2 Proper Mounting with Back Plate

Item A is a back plate properly installed for required airflow to cool the unit.

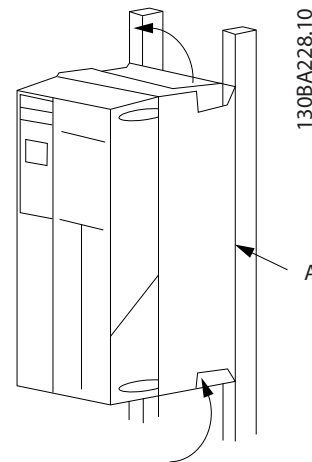

Illustration 2.3 Proper Mounting with Railings

NOTE

Back plate is needed when mounted on railings.

2.3.4 Tightening Torques

See 10.4.1 Connection Tightening Torques for proper tightening specifications.

2.4 Electrical Installation

This section contains detailed instructions for wiring the frequency converter. The following tasks are described.

- Wiring the motor to the frequency converter output terminals
- Wiring the AC mains to the frequency converter input terminals
- Connecting control and serial communication wiring
- After power has been applied, checking input and motor power; programming control terminals for their intended functions

2

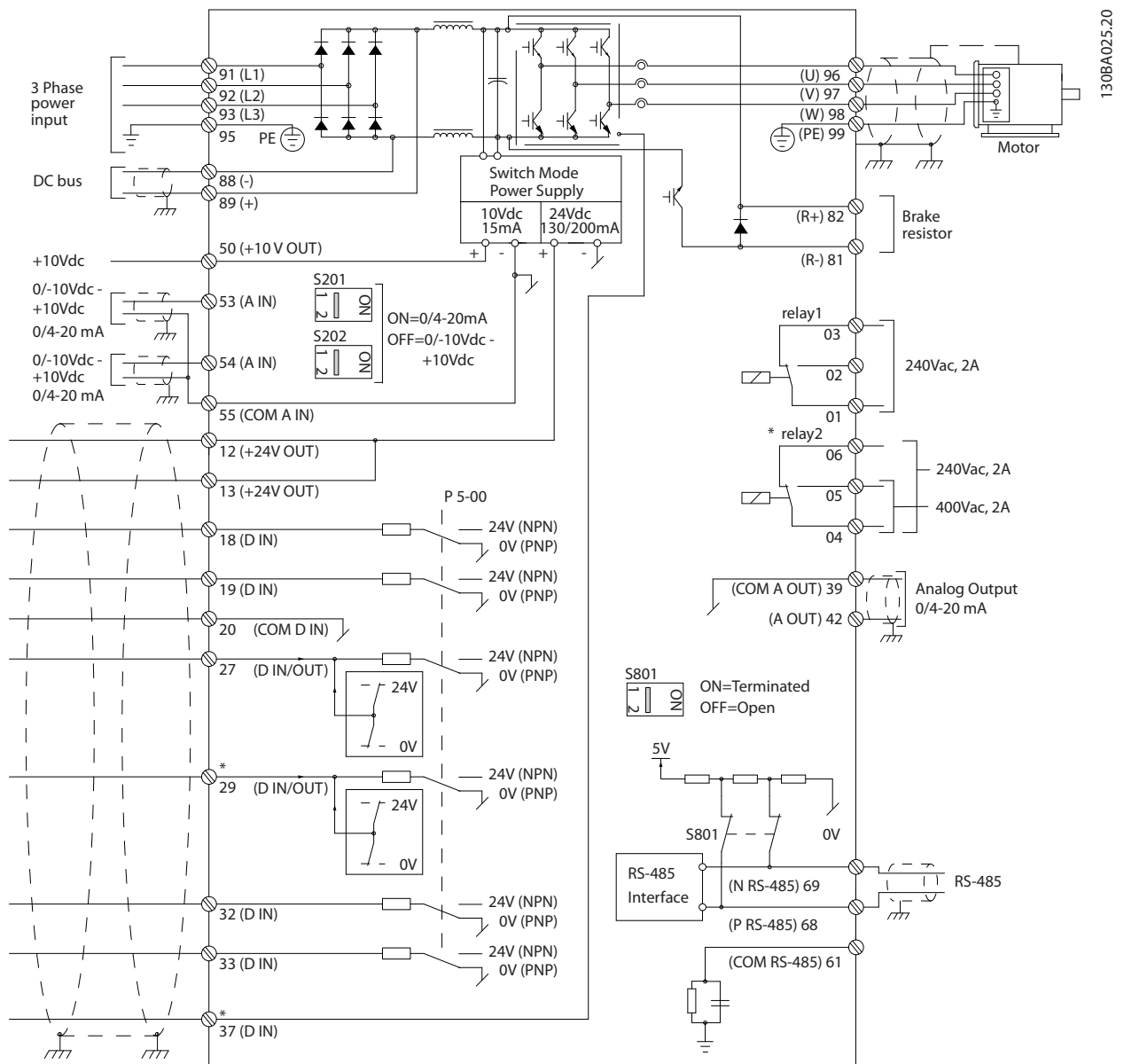

Illustration 2.4 Basic Wiring Schematic Drawing.

A=Analog, D=Digital

Terminal 37 is used for Safe Stop. For Safe Stop installation instructions, refer to the Design Guide.

* Terminal 37 is not included in AutomationDrive FC 301 (except frame size A1). Relay 2 and terminal 29 have no function in AutomationDrive FC 301.

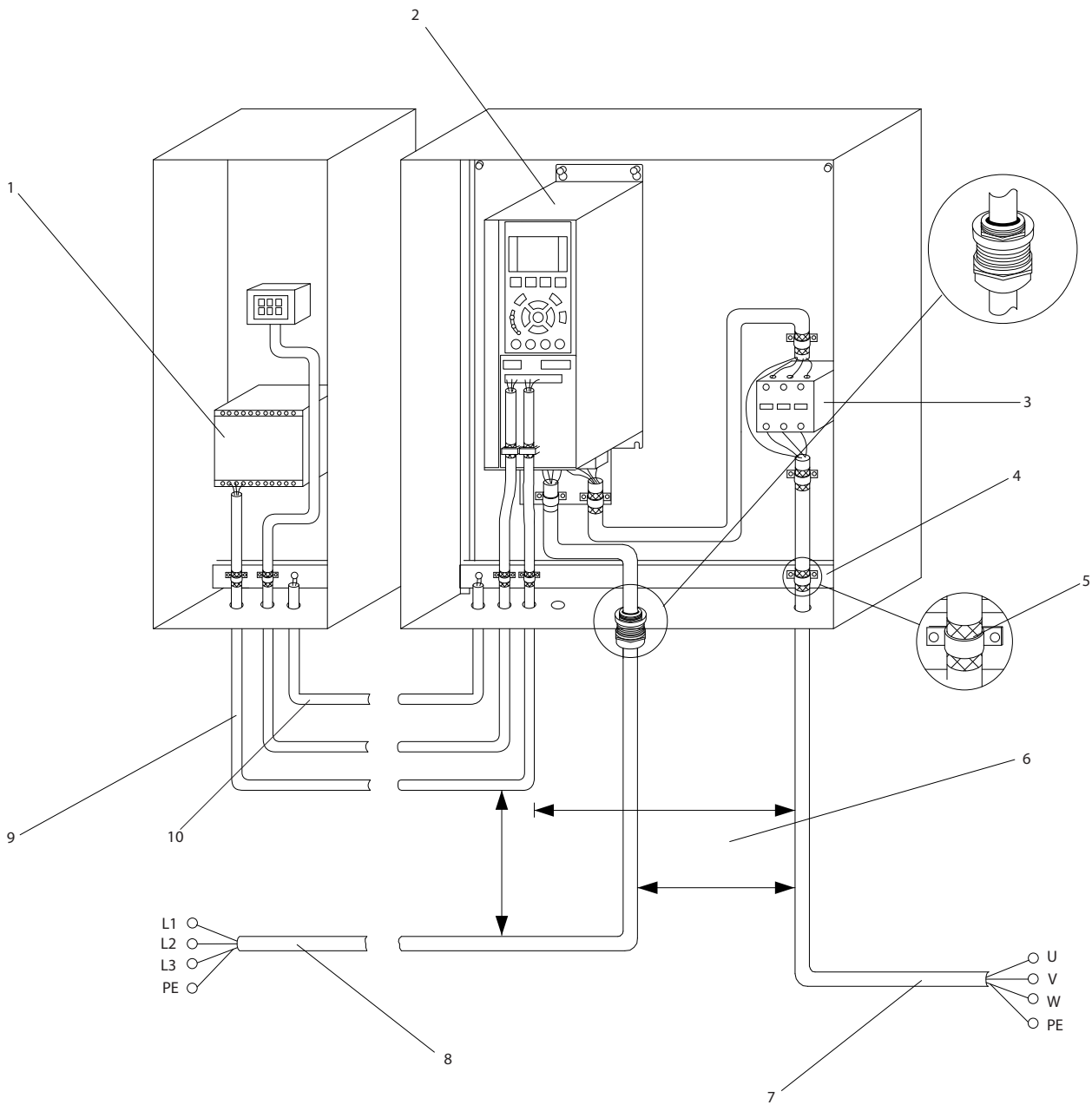

Illustration 2.5 Typical Electrical Connection

1	PLC	6	Min. 200mm (7.9in) between control cables, motor and mains
2	Frequency converter	7	Motor, 3-phase and PE
3	Output contactor (Generally not recommended)	8	Mains, 3-phase and reinforced PE
4	Earth (grounding) rail (PE)	9	Control wiring
5	Cable insulation (stripped)	10	Equalising min. 16mm ² (0.025in)

2.4.1 Requirements

⚠ WARNING

EQUIPMENT HAZARD!

Rotating shafts and electrical equipment can be hazardous. All electrical work must conform to national and local electrical codes. It is strongly recommended that installation, start up, and maintenance be performed only by trained and qualified personnel. Failure to follow these guidelines could result in death or serious injury.

CAUTION

WIRING ISOLATION!

Run input power, motor wiring and control wiring in three separate metallic conduits or use separated shielded cable for high frequency noise isolation. Failure to isolate power, motor and control wiring could result in less than optimum frequency converter and associated equipment performance.

For your safety, comply with the following requirements.

- Electronic controls equipment is connected to hazardous mains voltage. Extreme care should be taken to protect against electrical hazards when applying power to the unit.
- Run motor cables from multiple frequency converters separately. Induced voltage from output motor cables run together can charge equipment capacitors even with the equipment turned off and locked out.

Overload and Equipment Protection

- An electronically activated function within the frequency converter provides overload protection for the motor. The overload calculates the level of increase to activate timing for the trip (controller output stop) function. The higher the current draw, the quicker the trip response. The overload provides Class 20 motor protection. See *8 Warnings and Alarms* for details on the trip function.
- Because the motor wiring carries high frequency current, it is important that wiring for mains, motor power, and control are run separately. Use metallic conduit or separated shielded wire. Failure to isolate power, motor, and control wiring could result in less than optimum equipment performance.
- All frequency converters must be provided with short-circuit and over-current protection. Input fusing is required to provide this protection, see *Illustration 2.6*. If not factory supplied, fuses must be provided by the installer as part of installation. See maximum fuse ratings in *10.3 Fuse Tables*.

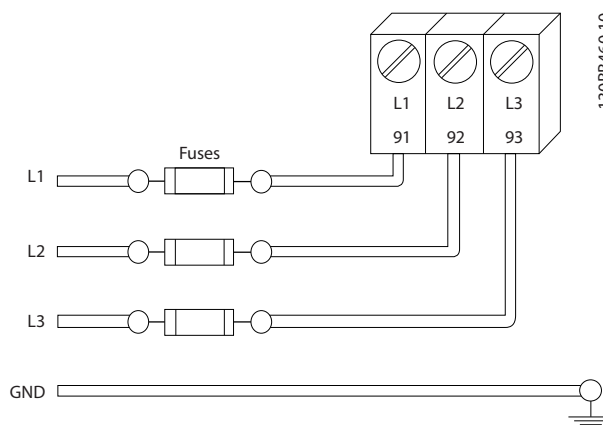

Illustration 2.6 Frequency Converter Fuses

Wire Type and Ratings

- All wiring must comply with local and national regulations regarding cross-section and ambient temperature requirements.
- Danfoss recommends that all power connections be made with a minimum 75° C rated copper wire.
- See *10.1 Power-dependent Specifications* for recommended wire sizes.

2.4.2 Earth (Grounding) Requirements

⚠ WARNING

GROUNDING HAZARD!

For operator safety, it is important to ground frequency converter properly in accordance with national and local electrical codes as well as instructions contained within these instructions. Ground currents are higher than 3,5mA. Failure to ground frequency converter properly could result in death or serious injury.

NOTE

It is the responsibility of the user or certified electrical installer to ensure correct grounding (earthing) of the equipment in accordance with national and local electrical codes and standards.

- Follow all local and national electrical codes to ground electrical equipment properly
- Proper protective grounding for equipment with ground currents higher than 3,5mA must be established, see *Leakage Current (>3,5mA)*
- A dedicated ground wire is required for input power, motor power and control wiring
- Use the clamps provided with on the equipment for proper ground connections

- Do not ground one frequency converter to another in a “daisy chain” fashion
- Keep the ground wire connections as short as possible
- Use of high-strand wire to reduce electrical noise is recommended
- Follow motor manufacturer wiring requirements

2.4.2.1 Leakage Current (>3,5mA)

Follow national and local codes regarding protective earthing of equipment with a leakage current > 3,5mA. Frequency converter technology implies high frequency switching at high power. This will generate a leakage current in the earth connection. A fault current in the frequency converter at the output power terminals might contain a DC component which can charge the filter capacitors and cause a transient earth current. The earth leakage current depends on various system configurations including RFI filtering, screened motor cables, and frequency converter power.

EN/IEC61800-5-1 (Power Drive System Product Standard) requires special care if the leakage current exceeds 3,5mA. Earth grounding must be reinforced in one of the following ways:

- Earth ground wire of at least 10mm²
- Two separate earth ground wires both complying with the dimensioning rules

See EN 60364-5-54 § 543.7 for further information.

Using RCDs

Where residual current devices (RCDs), also known as earth leakage circuit breakers (ELCBs), are used, comply with the following:

- Use RCDs of type B only which are capable of detecting AC and DC currents
- Use RCDs with an inrush delay to prevent faults due to transient earth currents
- Dimension RCDs according to the system configuration and environmental considerations

2.4.2.2 Grounding Using Shielded Cable

Earthing (grounding) clamps are provided for motor wiring (see *Illustration 2.7*).

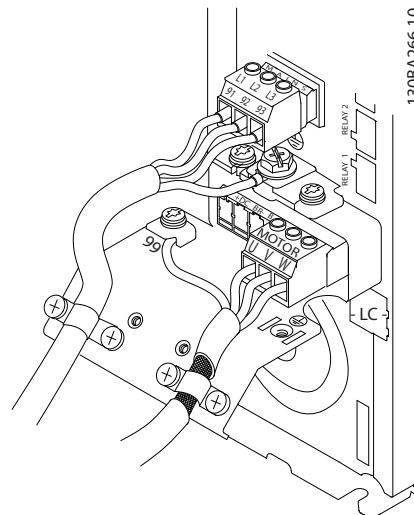

Illustration 2.7 Grounding with Shielded Cable

2.4.3 Motor Connection

WARNING

INDUCED VOLTAGE!

Run output motor cables from multiple frequency converters separately. Induced voltage from output motor cables run together can charge equipment capacitors even with the equipment turned off and locked out. Failure to run output motor cables separately could result in death or serious injury.

- For maximum wire sizes see *10.1 Power-dependent Specifications*
- Comply with local and national electrical codes for cable sizes
- Motor wiring knockouts or access panels are provided at the base of IP21 and higher (NEMA1/12) units
- Do not install power factor correction capacitors between the frequency converter and the motor
- Do not wire a starting or pole-changing device between the frequency converter and the motor
- Connect the 3-phase motor wiring to terminals 96 (U), 97 (V), and 98 (W)
- Ground the cable in accordance with grounding instructions provided
- Torque terminals in accordance with the information provided in *10.4.1 Connection Tightening Torques*

- Follow motor manufacturer wiring requirements

Illustration 2.8 represents mains input, motor, and earth grounding for basic frequency converters. Actual configurations vary with unit types and optional equipment.

2

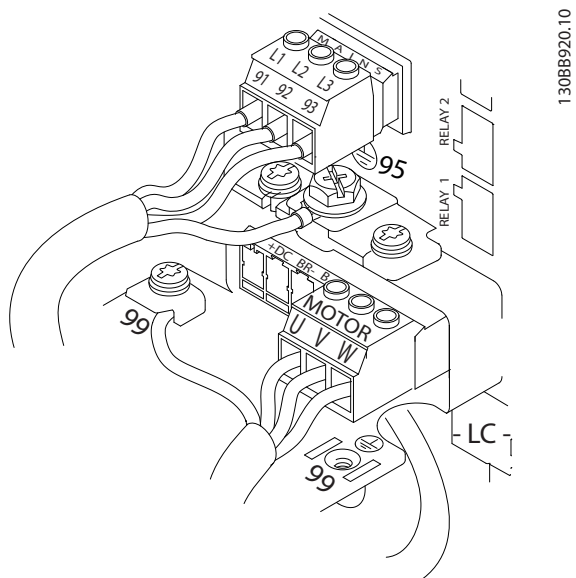

Illustration 2.8 Example of Motor, Mains and Earth Wiring

2.4.4 AC Mains Connection

- Size wiring based upon the input current of the frequency converter. For maximum wire sizes see 10.1 Power-dependent Specifications.
- Comply with local and national electrical codes for cable sizes.
- Connect 3-phase AC input power wiring to terminals L1, L2, and L3 (see Illustration 2.8).
- Depending on the configuration of the equipment, input power will be connected to the mains input terminals or the input disconnect.
- Ground the cable in accordance with grounding instructions provided in 2.4.2 Earth (Grounding) Requirements
- All frequency converters may be used with an isolated input source as well as with ground reference power lines. When supplied from an isolated mains source (IT mains or floating delta) or TT/TN-S mains with a grounded leg (grounded delta), set 14-50 RFI Filter to OFF. When off, the internal RFI filter capacitors between the chassis and the intermediate circuit are isolated to avoid damage to the intermediate circuit and to reduce earth capacity currents in accordance with IEC 61800-3.

2.4.5 Control Wiring

- Isolate control wiring from high power components in the frequency converter.
- If the frequency converter is connected to a thermistor, for PELV isolation, optional thermistor control wiring must be reinforced/double insulated. A 24 VDC supply voltage is recommended.

2.4.5.1 Access

- Remove access cover plate with a screw driver. See Illustration 2.9.
- Or remove front cover by loosening attaching screws. See Illustration 2.10.

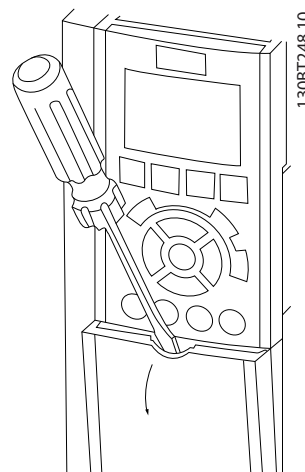

Illustration 2.9 Control Wiring Access for A2, A3, B3, B4, C3 and C4 Enclosures

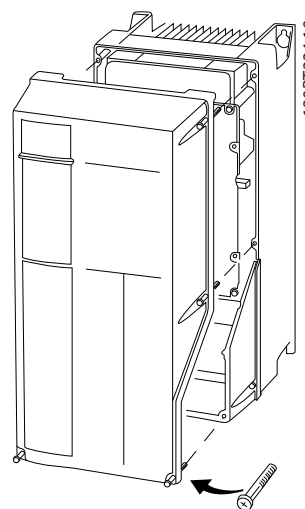

Illustration 2.10 Control Wiring Access for A4, A5, B1, B2, C1 and C2 Enclosures

Please see Table 2.2 before tightening the covers.

Frame	IP20	IP21	IP55	IP66
A4/A5	-	-	2	2
B1	-	*	2.2	2.2
B2	-	*	2.2	2.2
C1	-	*	2.2	2.2
C2	-	*	2.2	2.2

* No screws to tighten
 - Does not exist

Table 2.2 Tightening Torques for Covers (Nm)

2.4.5.2 Control Terminal Types

Illustration 2.11 and shows the removable frequency converter connectors. Terminal functions and default settings are summarized in Table 2.3.

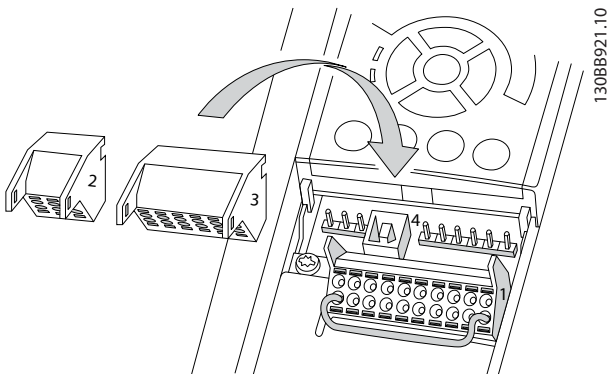

Illustration 2.11 Control Terminal Locations

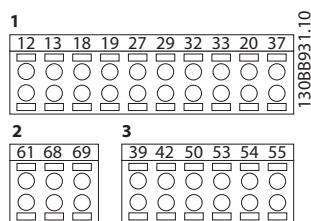

Illustration 2.12 Terminal Numbers

- **Connector 1** provides four programmable digital inputs terminals, two additional digital terminals programmable as either input or output, a 24V DC terminal supply voltage, and a common for optional customer supplied 24V DC voltage. FC 302 and FC 301 (optional in A1 enclosure) also provide a digital input for STO (Safe Torque Off) function.
- **Connector 2** terminals (+)68 and (-)69 are for an RS-485 serial communications connection
- **Connector 3** provides two analog inputs, one analog output, 10V DC supply voltage, and commons for the inputs and output
- **Connector 4** is a USB port available for use with the MCT 10 Set-up Software

- Also provided are two Form C relay outputs that are in various locations depending upon the frequency converter configuration and size
- Some options available for ordering with the unit may provide additional terminals. See the manual provided with the equipment option.

See 10.2 General Technical Data for terminal ratings details.

Terminal description			
Terminal	Parameter	Default setting	Description
Digital inputs/outputs			
12, 13	-	+24V DC	24V DC supply voltage. Maximum output current is 200mA total (130mA for FC 301) for all 24V loads. Useable for digital inputs and external transducers.
18	5-10	[8] Start	Digital inputs.
19	5-11	[10] Reversing	
32	5-14	[0] No operation	
33	5-15	[0] No operation	
27	5-12	[2] Coast inverse	Selectable for either digital input or output.
29	5-13	[14] JOG	Default setting is input.
20	-		Common for digital inputs and 0V potential for 24V supply.
37	-	Safe Torque Off (STO)	Safe input. Used for STO.
Analog inputs/outputs			
39	-		Common for analog output
42	6-50	[0] No operation	Programmable analog output. The analog signal is 0-20mA or 4-20mA at a maximum of 500Ω
50	-	+10V DC	10V DC analog supply voltage. 15mA maximum commonly used for potentiometer or thermistor.
53	6-1	Reference	Analog input.
54	6-2	Feedback	Selectable for voltage or current. Switches A53 and A54 select mA or V.
55	-		Common for analog input

Terminal description			
Terminal	Parameter	Default setting	Description
Serial communication			
61	-		Integrated RC-Filter for cable screen. ONLY for connecting the screen when experiencing EMC problems.
68 (+)	8-3		RS-485 Interface. A control card switch is provided for termination resistance.
69 (-)	8-3		
Relays			
01, 02, 03	5-40 [0]	[0] No operation	Form C relay output. Usable for AC or DC voltage and resistive or inductive loads.
04, 05, 06	5-40 [1]	[0] No operation	

Table 2.3 Terminal Description

2.4.5.3 Wiring to Control Terminals

Control terminal connectors can be unplugged from the frequency converter for ease of installation, as shown in *Illustration 2.11*.

1. Open the contact by inserting a small screwdriver into the slot above or below the contact, as shown in *Illustration 2.13*.
2. Insert the bared control wire into the contact.
3. Remove the screwdriver to fasten the control wire into the contact.
4. Ensure the contact is firmly established and not loose. Loose control wiring can be the source of equipment faults or less than optimal operation.

See 10.1 *Power-dependent Specifications* for control terminal wiring sizes.

See 6 *Application Set-Up Examples* for typical control wiring connections.

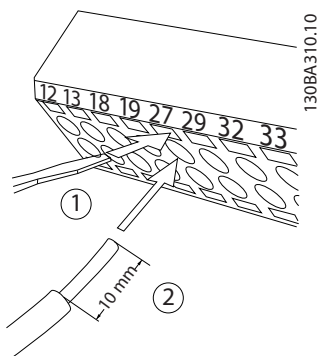

Illustration 2.13 Connecting Control Wiring

2.4.5.4 Using Screened Control Cables

Correct screening

The preferred method in most cases is to secure control and serial communication cables with screening clamps provided at both ends to ensure best possible high frequency cable contact.

If the earth potential between the frequency converter and the PLC is different, electric noise may occur that will disturb the entire system. Solve this problem by fitting an equalizing cable next to the control cable. Minimum cable cross section: 16 mm².

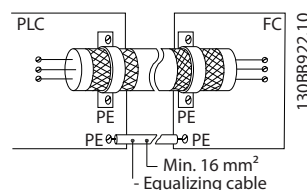

50/60Hz ground loops

With very long control cables, ground loops may occur. To eliminate ground loops, connect one end of the screen-to-ground with a 100nF capacitor (keeping leads short).

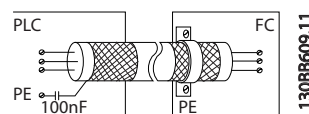

Avoid EMC noise on serial communication

This terminal is connected to earth via an internal RC link. Use twisted-pair cables to reduce interference between conductors. The recommended method is shown below:

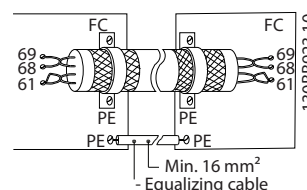

Alternatively, the connection to terminal 61 can be omitted:

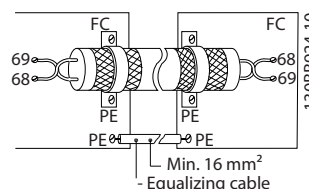

2.4.5.5 Control Terminal Functions

Frequency converter functions are commanded by receiving control input signals.

- Each terminal must be programmed for the function it will be supporting in the parameters

associated with that terminal. See Table 2.3 for terminals and associated parameters.

- It is important to confirm that the control terminal is programmed for the correct function. See 4 *User Interface* for details on accessing parameters and 5 *About Frequency Converter Programming* for details on programming.
- The default terminal programming is intended to initiate frequency converter functioning in a typical operational mode.

2.4.5.6 Jumper Terminals 12 and 27

A jumper wire may be required between terminal 12 (or 13) and terminal 27 for the frequency converter to operate when using factory default programming values.

- Digital input terminal 27 is designed to receive an 24V DC external interlock command. In many applications, the user wires an external interlock device to terminal 27
- When no interlock device is used, wire a jumper between control terminal 12 (recommended) or 13 to terminal 27. This provides an internal 24V signal on terminal 27
- No signal present prevents the unit from operating
- When the status line at the bottom of the LCP reads AUTO REMOTE COAST, this indicates that the unit is ready to operate but is missing an input signal on terminal 27.
- When factory installed optional equipment is wired to terminal 27, do not remove that wiring

2.4.5.7 Terminal 53 and 54 Switches

- Analog input terminals 53 and 54 can select either voltage (-10 to 10V) or current (0/4-20mA) input signals
- Remove power to the frequency converter before changing switch positions
- Set switches A53 and A54 to select the signal type. U selects voltage, I selects current.
- The switches are accessible when the LCP has been removed (see Illustration 2.14). Note that some option cards available for the unit may cover these switches and must be removed to change switch settings. Always remove power to the unit before removing option cards.
- Terminal 53 default is for a speed reference signal in open loop set in 16-61 *Terminal 53 Switch Setting*
- Terminal 54 default is for a feedback signal in closed loop set in 16-63 *Terminal 54 Switch Setting*

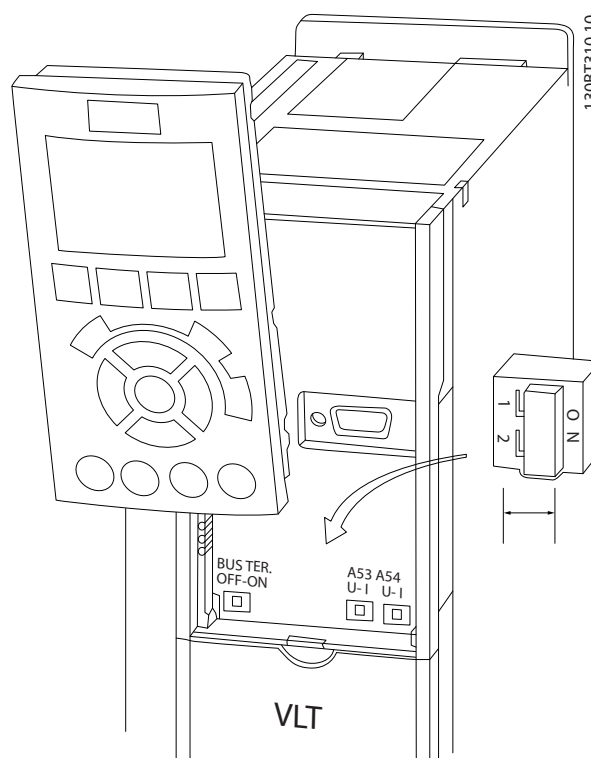

Illustration 2.14 Location of Terminals 53 and 54 Switches and Bus Termination Switch

2.4.5.8 Terminal 37

Terminal 37 Safe Stop Function

The FC 302 and FC 301 (optional for A1 enclosure) is available with safe stop functionality via control terminal 37. Safe stop disables the control voltage of the power semiconductors of the frequency converter output stage which in turn prevents generating the voltage required to rotate the motor. When the Safe Stop (T37) is activated, the frequency converter issues an alarm, trips the unit, and coasts the motor to a stop. Manual restart is required. The safe stop function can be used for stopping the frequency converter in emergency stop situations. In the normal operating mode when safe stop is not required, use the frequency converter's regular stop function instead. When automatic restart is used – the requirements according to ISO 12100-2 paragraph 5.3.2.5 must be fulfilled.

Liability Conditions

It is the responsibility of the user to ensure personnel installing and operating the Safe Stop function:

- Read and understand the safety regulations concerning health and safety/accident prevention
- Understand the generic and safety guidelines given in this description and the extended description in the *Design Guide*
- Have a good knowledge of the generic and safety standards applicable to the specific application

User is defined as: integrator, operator, servicing, maintenance staff.

Standards

Use of safe stop on terminal 37 requires that the user satisfies all provisions for safety including relevant laws, regulations and guidelines. The optional safe stop function complies with the following standards.

- EN 954-1: 1996 Category 3
- IEC 60204-1: 2005 category 0 – uncontrolled stop
- IEC 61508: 1998 SIL2
- IEC 61800-5-2: 2007 – safe torque off (STO) function
- IEC 62061: 2005 SIL CL2
- ISO 13849-1: 2006 Category 3 PL d
- ISO 14118: 2000 (EN 1037) – prevention of unexpected start up

The information and instructions of the instruction manual are not sufficient for a proper and safe use of the safe stop functionality. The related information and instructions of the relevant *Design Guide* must be followed.

Protective Measures

- Safety engineering systems may only be installed and commissioned by qualified and skilled personnel
- The unit must be installed in an IP54 cabinet or in an equivalent environment
- The cable between terminal 37 and the external safety device must be short circuit protected according to ISO 13849-2 table D.4
- If any external forces influence the motor axis (e.g. suspended loads), additional measures (e.g., a safety holding brake) are required in order to eliminate hazards

Safe Stop Installation and Set-Up



SAFE STOP FUNCTION!

The safe stop function does NOT isolate mains voltage to the frequency converter or auxiliary circuits. Perform work on electrical parts of the frequency converter or the motor only after isolating the mains voltage supply and waiting the length of time specified under Safety in this manual. Failure to isolate the mains voltage supply from the unit and waiting the time specified could result in death or serious injury.

- It is not recommended to stop the frequency converter by using the Safe Torque Off function. If a running frequency converter is stopped by using the function, the unit will trip and stop by coasting. If this is not acceptable, e.g. causes danger, the frequency converter and machinery must be stopped using the appropriate stopping mode

before using this function. Depending on the application a mechanical brake may be required.

- Concerning synchronous and permanent magnet motor frequency converters in case of a multiple IGBT power semiconductor failure: In spite of the activation of the Safe torque off function, the frequency converter system can produce an alignment torque which maximally rotates the motor shaft by 180/p degrees. p denotes the pole pair number.
- This function is suitable for performing mechanical work on the frequency converter system or affected area of a machine only. It does not provide electrical safety. This function should not be used as a control for starting and/or stopping the frequency converter.

The following requirements have to be met to perform a safe installation of the frequency converter:

1. Remove the jumper wire between control terminals 37 and 12 or 13. Cutting or breaking the jumper is not sufficient to avoid short-circuiting. (See jumper on *Illustration 2.15*.)
2. Connect an external Safety monitoring relay via a NO safety function (the instruction for the safety device must be followed) to terminal 37 (safe stop) and either terminal 12 or 13 (24V DC). The Safety monitoring relay must comply with Category 3 (EN 954-1) / PL "d" (ISO 13849-1).

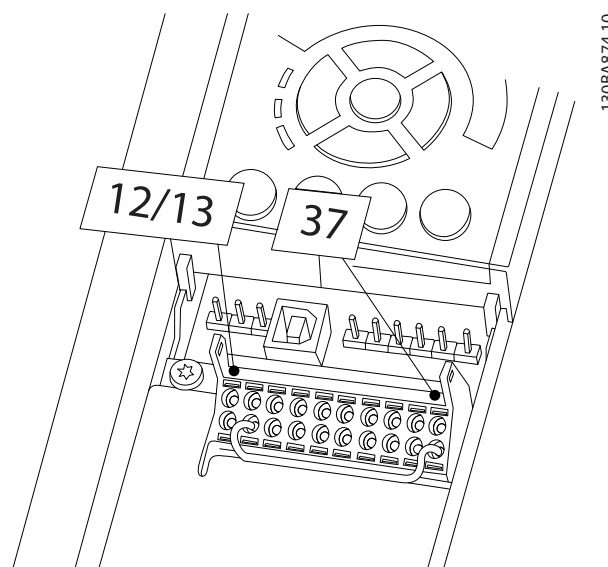
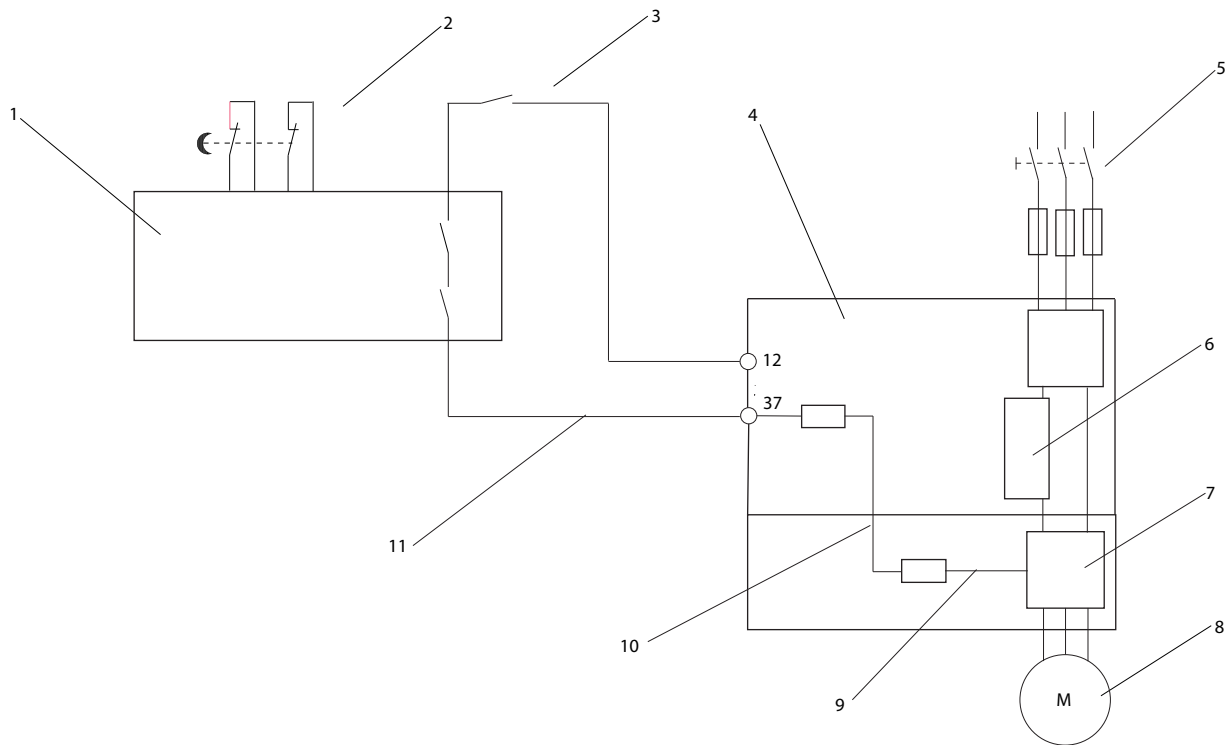

Illustration 2.15 Jumper between Terminal 12/13 (24V) and 37



13088749.10

2

Illustration 2.16 Installation to Achieve a Stopping Category 0 (EN 60204-1) with Safety Cat. 3 (EN 954-1) / PL "d" (ISO 13849-1).

1	Safety device Cat. 3 (circuit interrupt device, possibly with release input)	7	Inverter
2	Door contact	8	Motor
3	Contactora (Coast)	9	5V DC
4	Frequency converter	10	Safe channel
5	Mains	11	Short-circuit protected cable (if not inside installation cabinet)
6	Control board		

Safe Stop Commissioning Test

After installation and before first operation, perform a commissioning test of the installation making use of safe stop. Moreover, perform the test after each modification of the installation.

2.4.5.9 Mechanical Brake Control

In hoisting/lowering applications, it is necessary to be able to control an electro-mechanical brake:

- Control the brake using any relay output or digital output (terminal 27 or 29).
- Keep the output closed (voltage-free) as long as the frequency converter is unable to 'support' the motor, for example due to the load being too heavy.
- Select *Mechanical brake control* [32] in par. 5-4* for applications with an electro-mechanical brake.
- The brake is released when the motor current exceeds the preset value in *2-20 Release Brake Current*.
- The brake is engaged when the output frequency is less than the frequency set in *2-21 Activate Brake Speed [RPM]* or *2-22 Activate Brake Speed [Hz]*, and only if the frequency converter carries out a stop command.

If the frequency converter is in alarm mode or in an over-voltage situation, the mechanical brake immediately cuts in.

In the vertical movement, the key point is that the load must be held, stopped, controlled (raised, lowered) in a perfectly safe mode during the entire operation. Because the frequency converter is not a safety device, the crane/lift designer (OEM) must decide on the type and number of safety devices (e.g. speed switch, emergency brakes etc.) to be used, in order to be able to stop the load in case of emergency or malfunction of the system, according to relevant national crane/lift regulations.

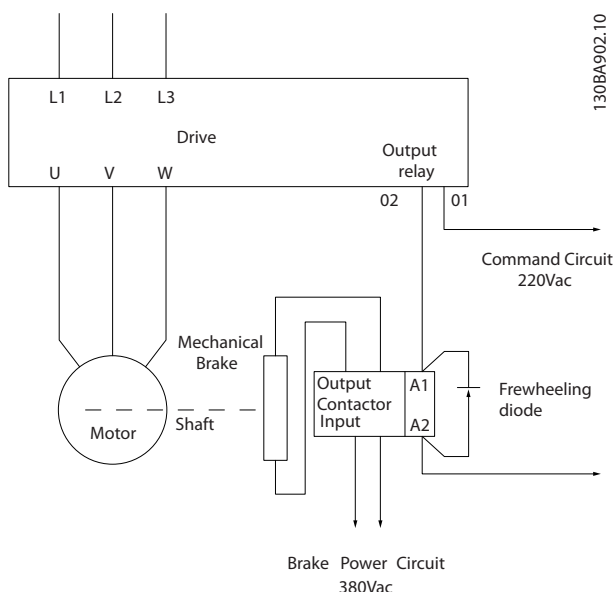

Illustration 2.17 Connecting the Mechanical Brake to the Frequency Converter

2.4.6 Serial Communication

Connect RS-485 serial communication wiring to terminals (+)68 and (-)69.

- Screened serial communication cable is recommended
- See 2.4.2 *Earth (Grounding) Requirements* for proper grounding

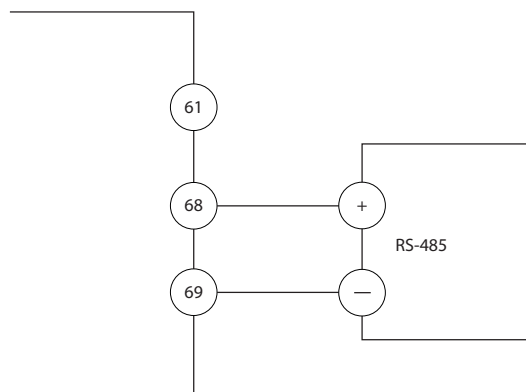

Illustration 2.18 Serial Communication Wiring Diagram

For basic serial communication set-up, select the following

1. Protocol type in *8-30 Protocol*.
 2. Frequency converter address in *8-31 Address*.
 3. Baud rate in *8-32 Baud Rate*.
- Two communication protocols are internal to the frequency converter. Follow motor manufacturer wiring requirements.
Danfoss FC
Modbus RTU
 - Functions can be programmed remotely using the protocol software and RS-485 connection or in parameter group 8-** *Communications and Options*
 - Selecting a specific communication protocol changes various default parameter settings to match that protocol's specifications along with making additional protocol-specific parameters available
 - Option cards which install into the frequency converter are available to provide additional communication protocols. See the option-card documentation for installation and operation instructions

3 Start Up and Functional Testing

3.1 Pre-start

3.1.1 Safety Inspection

⚠ WARNING

HIGH VOLTAGE!

If input and output connections have been connected improperly, there is potential for high voltage on these terminals. If power leads for multiple motors are improperly run in same conduit, there is potential for leakage current to charge capacitors within the frequency converter, even when disconnected from mains input. For initial start up, make no assumptions about power components. Follow pre-start procedures. Failure to follow pre-start procedures could result in personal injury or damage to equipment.

1. Input power to the unit must be OFF and locked out. Do not rely on the frequency converter disconnect switches for input power isolation.
2. Verify that there is no voltage on input terminals L1 (91), L2 (92), and L3 (93), phase-to-phase and phase-to-ground,
3. Verify that there is no voltage on output terminals 96 (U), 97 (V), and 98 (W), phase-to-phase and phase-to-ground.
4. Confirm continuity of the motor by measuring ohm values on U-V (96-97), V-W (97-98), and W-U (98-96).
5. Check for proper grounding of the frequency converter as well as the motor.
6. Inspect the frequency converter for loose connections on terminals.
7. Record the following motor-nameplate data: power, voltage, frequency, full load current, and nominal speed. These values are needed to program motor nameplate data later.
8. Confirm that the supply voltage matches voltage of frequency converter and motor.

3.1.2 Start Up Check List

CAUTION

Before applying power to the unit, inspect the entire installation as detailed in *Table 3.1*. Check mark those items when completed.

3

Inspect for	Description	<input checked="" type="checkbox"/>
Auxiliary equipment	<ul style="list-style-type: none"> Look for auxiliary equipment, switches, disconnects, or input fuses/circuit breakers that may reside on input power side of frequency converter or output side to motor. Examine their operational readiness and ensure that they are ready in all respects for operation at full speed. Check function and installation of any sensors used for feedback to frequency converter Remove power factor correction caps on motor(s), if present 	
Cable routing	<ul style="list-style-type: none"> Ensure that input power, motor wiring, and control wiring are separated or in three separate metallic conduits for high frequency noise isolation 	
Control wiring	<ul style="list-style-type: none"> Check for broken or damaged wires and loose connections Check that control wiring is isolated from power and motor wiring for noise immunity Check the voltage source of the signals, if necessary The use of shielded cable or twisted pair is recommended. Ensure that the shield is terminated correctly. 	
Cooling clearance	<ul style="list-style-type: none"> Measure that top and bottom clearance is adequate to ensure proper air flow for cooling 	
EMC considerations	<ul style="list-style-type: none"> Check for proper installation regarding electromagnetic compatibility 	
Environmental considerations	<ul style="list-style-type: none"> See equipment label for the maximum ambient operating temperature limits Humidity levels must be 5-95% non-condensing 	
Fusing and circuit breakers	<ul style="list-style-type: none"> Check for proper fusing or circuit breakers Check that all fuses are inserted firmly and in operational condition and that all circuit breakers are in the open position 	
Grounding	<ul style="list-style-type: none"> The unit requires a ground wire from its chassis to the building ground Check for good ground connections that are tight and free of oxidation Grounding to conduit or mounting the back panel to a metal surface is not a suitable ground 	
Input and output power wiring	<ul style="list-style-type: none"> Check for loose connections Check that motor and mains are in separate conduit or separated screened cables 	
Panel interior	<ul style="list-style-type: none"> Inspect that the unit interior is free of dirt, metal chips, moisture, and corrosion 	
Switches	<ul style="list-style-type: none"> Ensure that all switch and disconnect settings are in the proper position 	
Vibration	<ul style="list-style-type: none"> Check that the unit is mounted solidly or that shock mounts are used, as necessary Look for any unusual amount of vibration the unit may be subjected to 	

Table 3.1 Start Up Check List

3.2 Applying Power to the Frequency Converter

⚠ WARNING

HIGH VOLTAGE!

Frequency converters contain high voltage when connected to AC mains. Installation, start-up and maintenance should be performed by qualified personnel only. Failure to perform installation, start-up and maintenance by qualified personnel could result in death or serious injury.

⚠ WARNING

UNINTENDED START!

When frequency converter is connected to AC mains, the motor may start at any time. The frequency converter, motor, and any driven equipment must be in operational readiness. Failure to be in operational readiness when the frequency converter is connected to AC mains could result in death, serious injury, equipment, or property damage.

1. Confirm input voltage is balanced within 3%. If not, correct input voltage imbalance before proceeding. Repeat procedure after voltage correction.
2. Ensure optional equipment wiring, if present, matches installation application.
3. Ensure that all operator devices are in the OFF position. Panel doors closed or cover mounted.
4. Apply power to the unit. DO NOT start the frequency converter at this time. For units with a disconnect switch, turn to the ON position to apply power to the frequency converter.

NOTE

If the status line at the bottom of the LCP reads **AUTO REMOTE COAST**, this indicates that the unit is ready to operate but is missing an input signal on terminal 27. See *Illustration 2.15* for details.

3.3 Basic Operational Programming

Frequency converters require basic operational programming prior to running for best performance. Basic operational programming requires entering motor-nameplate data for the motor being operated and the minimum and maximum motor speeds. Enter data in accordance with the following procedure. Parameter settings recommended are intended for start up and checkout purposes. Application settings may vary. See *4 User Interface* for detailed instructions on entering data through the LCP.

Enter data with power ON, but prior to operating the frequency converter.

1. Press [Main Menu] twice on the LCP.
2. Use the navigation keys to scroll to parameter group 0-** *Operation/Display* and press [OK].

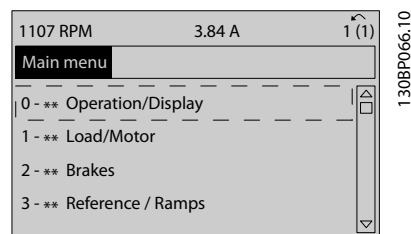

3. Use navigation keys to scroll to parameter group 0-0* *Basic Settings* and press [OK].

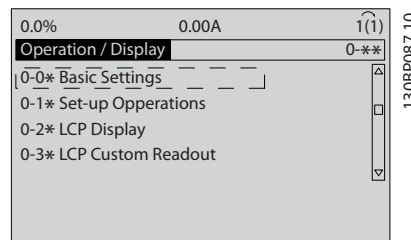

4. Use navigation keys to scroll to 0-03 *Regional Settings* and press [OK].

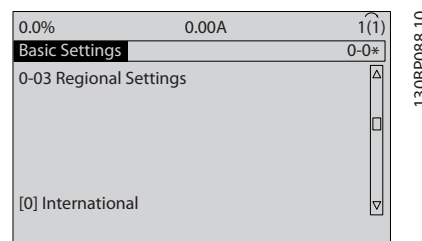

5. Use navigation keys to select *International* or *North America* as appropriate and press [OK]. (This changes the default settings for a number of basic parameters. See *5.4 International/North American Default Parameter Settings* for a complete list.)
6. Press [Quick Menu] on the LCP.



- Use the navigation keys to scroll to parameter group *Q2 Quick Setup* and press [OK].

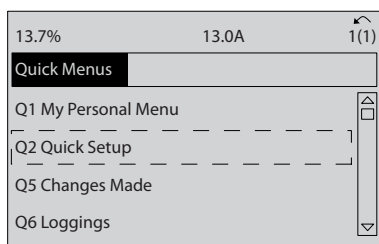

130BB847.10

- Select language and press [OK]. Then enter the motor data in parameters 1-20/1-21 through 1-25. The information can be found on the motor nameplate.

- 1-20 Motor Power [kW] or 1-21 Motor Power [HP]
- 1-22 Motor Voltage
- 1-23 Motor Frequency
- 1-24 Motor Current
- 1-25 Motor Nominal Speed

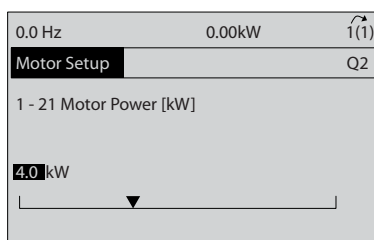

130BT772.10

- A jumper wire should be in place between control terminals 12 and 27. If this is the case, leave *5-12 Terminal 27 Digital Input* at factory default. Otherwise select *No Operation*. For frequency converters with an optional Danfoss bypass, no jumper wire is required.
- 3-02 Minimum Reference
- 3-03 Maximum Reference
- 3-41 Ramp 1 Ramp Up Time
- 3-42 Ramp 1 Ramp Down Time
- 3-13 Reference Site. Linked to Hand/Auto* Local Remote.

This concludes the quick set-up procedure. Press [Status] to return to the operational display.

3.4 Automatic Motor Adaptation

Automatic motor adaptation (AMA) is a test procedure that measures the electrical characteristics of the motor to optimize compatibility between the frequency converter and the motor.

- The frequency converter builds a mathematical model of the motor for regulating output motor current. The procedure also tests the input phase balance of electrical power. It compares the motor characteristics with the data entered in parameters 1-20 to 1-25.
- It does not cause the motor to run or harm to the motor
- Some motors may be unable to run the complete version of the test. In that case, select *Enable reduced AMA*
- If an output filter is connected to the motor, select *Enable reduced AMA*
- If warnings or alarms occur, see *8 Warnings and Alarms*
- Run this procedure on a cold motor for best results

To run AMA

- Press [Main Menu] to access parameters.
- Scroll to parameter group 1-** *Load and Motor*.
- Press [OK].
- Scroll to parameter group 1-2* *Motor Data*.
- Press [OK].
- Scroll to *1-29 Automatic Motor Adaptation (AMA)*.
- Press [OK].
- Select *Enable complete AMA*.
- Press [OK].
- Follow on-screen instructions.
- The test will run automatically and indicate when it is complete.

3.5 Check Motor Rotation

Prior to running the frequency converter, check the motor rotation.

1. Press [Hands on].
2. Press [▶] for positive speed reference.
3. Check that the speed displayed is positive.

When 1-06 Clockwise Direction is set to [0]* Normal (default clockwise):

- 4a. Verify that the motor turns clockwise.
- 5a. Verify that the LCP direction arrow is clockwise.

When 1-06 Clockwise Direction is set to [1] Inverse (counter-clockwise):

- 4b. Verify that the motor turns counter-clockwise.
- 5b. Verify that the LCP direction arrow is counter-clockwise.

3.6 Check Encoder Rotation

Check encoder rotation only if encoder feedback is used. Check encoder rotation in default open loop control.

1. Verify that the encoder connection is according to the wiring diagram:

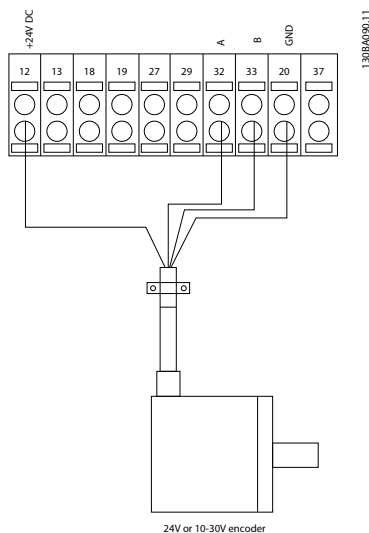

NOTE

When using an encoder option, refer to the option manual

2. Enter the Speed PID feed-back source in 7-00 Speed PID Feedback Source.
3. Press [Hand On]
4. Press [▶] for positive speed reference (1-06 Clockwise Direction at [0]* Normal).

5. Check in 16-57 Feedback [RPM] that the feed-back is positive

NOTE

If the feedback is negative, the encoder connection is wrong!

3.7 Local-control Test

CAUTION

MOTOR START!

Ensure that the motor, system, and any attached equipment is ready for start. It is the responsibility of the user to ensure safe operation under any operational condition. Failure to ensure that the motor, system, and any attached equipment is ready for start could result in personal injury or equipment damage.

NOTE

The hand on key on the LCP provides a local start command to the frequency converter. The OFF key provides the stop function.

When operating in local mode, the up and down arrows on the LCP increase and decrease the speed output of the frequency converter. The left and right arrow keys move the display cursor in the numeric display.

1. Press [Hand On].
2. Accelerate the frequency converter by pressing [▲] to full speed. Moving the cursor left of the decimal point provides quicker input changes.
3. Note any acceleration problems.
4. Press [OFF].
5. Note any deceleration problems.

If acceleration problems were encountered

- If warnings or alarms occur, see 8 Warnings and Alarms
- Check that motor data is entered correctly
- Increase the ramp-up time in 3-41 Ramp 1 Ramp Up Time
- Increase current limit in 4-18 Current Limit
- Increase torque limit in 4-16 Torque Limit Motor Mode

If deceleration problems were encountered

- If warnings or alarms occur, see 8 Warnings and Alarms
- Check that motor data is entered correctly
- Increase the ramp-down time in 3-42 Ramp 1 Ramp Down Time

- Enable overvoltage control in *2-17 Over-voltage Control*

See *8.4 Warning and Alarm Definitions* for resetting the frequency converter after a trip.

NOTE

3.1 Pre-start through 3.7 Local-control Test in this chapter conclude the procedures for applying power to the frequency converter, basic programming, set-up, and functional testing.

3

3.8 System Start Up

The procedure in this section requires user-wiring and application programming to be completed. *6 Application Set-Up Examples* is intended to help with this task. Other aids to application set-up are listed in *1.2 Additional Resources*. The following procedure is recommended after application set-up by the user is completed.

CAUTION

MOTOR START!

Ensure that the motor, system, and any attached equipment is ready for start. It is the responsibility of the user to ensure safe operation under any operational condition. Failure to ensure that the motor, system, and any attached equipment is ready for start could result in personal injury or equipment damage.

1. Press [Auto On].
2. Ensure that external control functions are properly wired to the frequency converter and all programming completed.
3. Apply an external run command.
4. Adjust the speed reference throughout the speed range.
5. Remove the external run command.
6. Note any problems.

If warnings or alarms occur, see *8 Warnings and Alarms*.

4 User Interface

4.1 Local Control Panel

The local control panel (LCP) is the combined display and keypad on the front of the unit. The LCP is the user interface to the frequency converter.

The LCP has several user functions.

- Start, stop, and control speed when in local control
- Display operational data, status, warnings and cautions
- Programming frequency converter functions
- Manually reset the frequency converter after a fault when auto-reset is inactive

An optional numeric LCP (NLCP) is also available. The NLCP operates in a manner similar to the LCP. See the Programming Guide for details on use of the NLCP.

NOTE

The display contrast can be adjusted by pressing [STATUS] and the up/ down key.

4.1.1 LCP Layout

The LCP is divided into four functional groups (see *Illustration 4.1*).

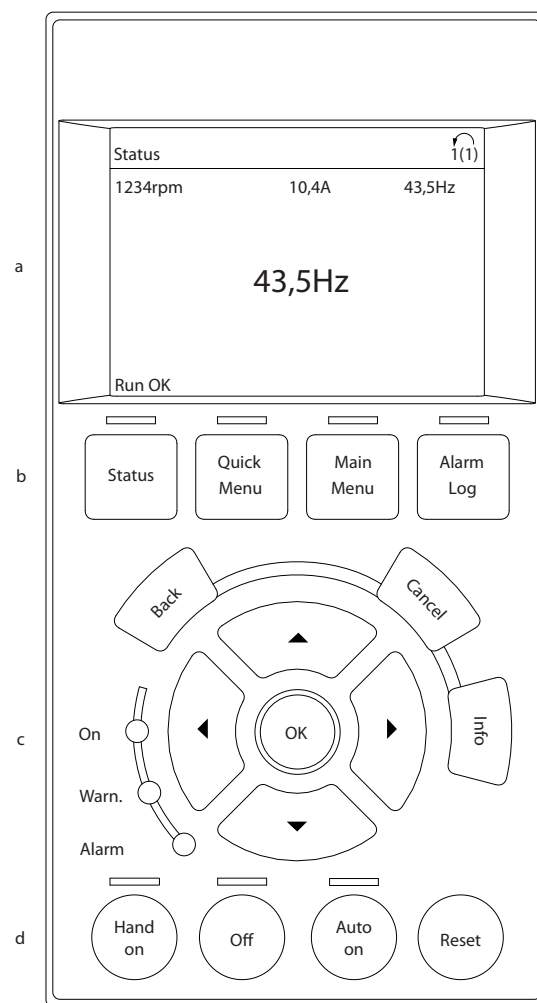

1308B465.10

Illustration 4.1 LCP

- Display area.
- Display menu keys for changing the display to show status options, programming, or error message history.
- Navigation keys for programming functions, moving the display cursor, and speed control in local operation. Also included are the status indicator lights.
- Operational mode keys and reset.

4.1.2 Setting LCP Display Values

The display area is activated when the frequency converter receives power from mains voltage, a DC bus terminal, or an external 24V supply.

The information displayed on the LCP can be customized for user application.

- Each display readout has a parameter associated with it.
- Options are selected in main menu 0-2*
- The frequency converter status at the bottom line of the display is generated automatically and is not selectable. See 7 *Status Messages* for definitions and details.

Display	Parameter number	Default setting
1.1	0-20	Speed [RPM]
1.2	0-21	Motor Current
1.3	0-22	Power [kW]
2	0-23	Frequency
3	0-24	Reference [%]

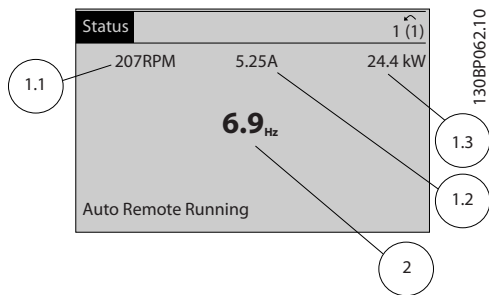
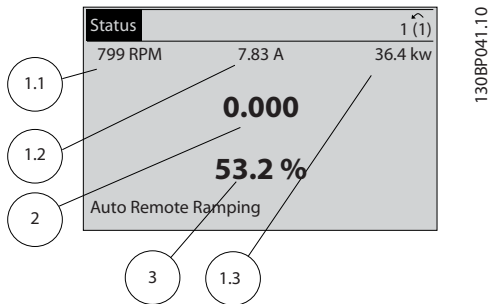

4.1.3 Display Menu Keys

Menu keys are used for menu access for parameter set-up, toggling through status display modes during normal operation, and viewing fault log data.

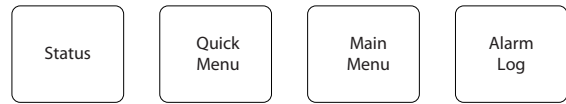

130BP045.10

Key	Function
Status	Press to show operational information. <ul style="list-style-type: none"> • In Auto mode, press and hold to toggle between status read-out displays • Press repeatedly to scroll through each status display • Press and hold [Status] plus [▲] or [▼] to adjust the display brightness • The symbol in the upper right corner of the display shows the direction of motor rotation and which set-up is active. This is not programmable.
Quick Menu	Allows access to programming parameters for initial set up instructions and many detailed application instructions. <ul style="list-style-type: none"> • Press to access <i>Q2 Quick Setup</i> for sequenced instructions to program the basic frequency controller set up • Follow the sequence of parameters as presented for the function set up
Main Menu	Allows access to all programming parameters. <ul style="list-style-type: none"> • Press twice to access top-level index • Press once to return to the last location accessed • Press and hold to enter a parameter number for direct access to that parameter
Alarm Log	Displays a list of current warnings, the last 10 alarms, and the maintenance log. <ul style="list-style-type: none"> • For details about the frequency converter before it entered the alarm mode, select the alarm number using the navigation keys and press [OK].

4.1.4 Navigation Keys

Navigation keys are used for programming functions and moving the display cursor. The navigation keys also provide speed control in local (hand) operation. Three frequency converter status indicator lights are also located in this area.

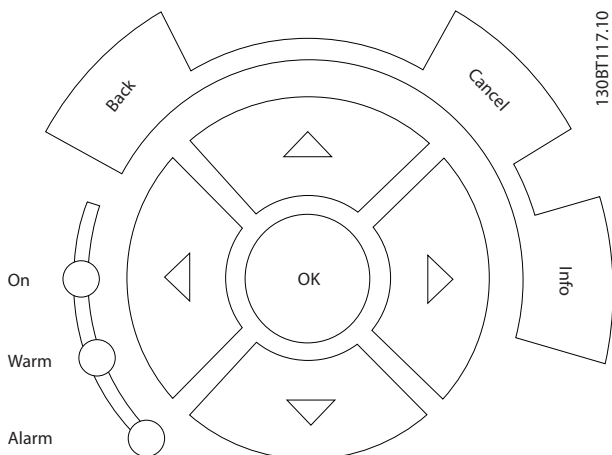

130BT117.10

Key	Function
Back	Reverts to the previous step or list in the menu structure.
Cancel	Cancels the last change or command as long as the display mode has not changed.
Info	Press for a definition of the function being displayed.
Navigation Keys	Use the four navigation arrows to move between items in the menu.
OK	Use to access parameter groups or to enable a choice.

Light	Indicator	Function
Green	ON	The ON light activates when the frequency converter receives power from mains voltage, a DC bus terminal, or an external 24 V supply.
Yellow	WARN	When warning conditions are met, the yellow WARN light comes on and text appears in the display area identifying the problem.
Red	ALARM	A fault condition causes the red alarm light to flash and an alarm text is displayed.

4.1.5 Operation Keys

Operation keys are found at the bottom of the control panel.

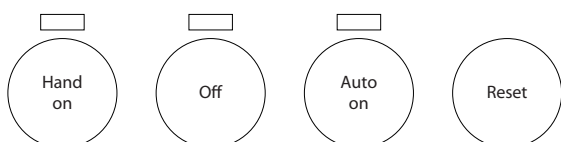

130BP046.10

Key	Function
Hand On	Press to start the frequency converter in local control. <ul style="list-style-type: none"> Use the navigation keys to control frequency converter speed An external stop signal by control input or serial communication overrides the local hand on
Off	Stops the motor but does not remove power to the frequency converter.
Auto On	Puts the system in remote operational mode. <ul style="list-style-type: none"> Responds to an external start command by control terminals or serial communication Speed reference is from an external source
Reset	Resets the frequency converter manually after a fault has been cleared.

4

4.2 Back Up and Copying Parameter Settings

Programming data is stored internally in the frequency converter.

- The data can be up loaded into the LCP memory as a storage back up
- Once stored in the LCP, the data can be downloaded back into the frequency converter
- Or downloaded into other frequency converters by connecting the LCP into those units and downloading the stored settings. (This is a quick way to program multiple units with the same settings.)
- Initialisation of the frequency converter to restore factory default settings does not change data stored in the LCP memory

WARNING

UNINTENDED START!

When frequency converter is connected to AC mains, the motor may start at any time. The frequency converter, motor, and any driven equipment must be in operational readiness. Failure to be in operational readiness when the frequency converter is connected to AC mains could result in death, serious injury, equipment, or property damage.

4.2.1 Uploading Data to the LCP

1. Press [OFF] to stop the motor before uploading or downloading data.
2. Go to *0-50 LCP Copy*.
3. Press [OK].
4. Select *All to LCP*.
5. Press [OK]. A progress bar shows the uploading process.
6. Press [Hand On] or [Auto On] to return to normal operation.

4.2.2 Downloading Data from the LCP

1. Press [OFF] to stop the motor before uploading or downloading data.
2. Go to *0-50 LCP Copy*.
3. Press [OK].
4. Select *All from LCP*.
5. Press [OK]. A progress bar shows the downloading process.
6. Press [Hand On] or [Auto On] to return to normal operation.

4.3 Restoring Default Settings

CAUTION

Initialisation restores the unit to factory default settings. Any programming, motor data, localization, and monitoring records will be lost. Uploading data to the LCP provides a backup prior to initialisation.

Restoring the frequency converter parameter settings back to default values is done by initialisation of the frequency converter. Initialisation can be through *14-22 Operation Mode* or manually.

- Initialisation using *14-22 Operation Mode* does not change frequency converter data such as operating hours, serial communication selections, personal menu settings, fault log, alarm log, and other monitoring functions
- Using *14-22 Operation Mode* is generally recommended
- Manual initialisation erases all motor, programming, localization, and monitoring data and restores factory default settings

4.3.1 Recommended Initialisation

1. Press [Main Menu] twice to access parameters.
2. Scroll to *14-22 Operation Mode*.
3. Press [OK].
4. Scroll to *Initialisation*.
5. Press [OK].
6. Remove power to the unit and wait for the display to turn off.
7. Apply power to the unit.

Default parameter settings are restored during start up. This may take slightly longer than normal.

8. Alarm 80 is displayed.
9. Press [Reset] to return to operation mode.

4.3.2 Manual Initialisation

1. Remove power to the unit and wait for the display to turn off.
2. Press and hold [Status], [Main Menu], and [OK] at the same time and apply power to the unit.

Factory default parameter settings are restored during start up. This may take slightly longer than normal.

Manual initialisation does not reset the following frequency converter information

- *15-00 Operating Hours*
- *15-03 Power Up's*
- *15-04 Over Temp's*
- *15-05 Over Volt's*

5 About Frequency Converter Programming

5.1 Introduction

The frequency converter is programmed for its application functions using parameters. Parameters are accessed by pressing either [Quick Menu] or [Main Menu] on the LCP. (See 4 User Interface for details on using the LCP function keys.) Parameters may also be accessed through a PC using the MCT 10 Set-up Software (see 5.6.1 Remote Programming with).

The quick menu is intended for initial start up (Q2-** Quick Set Up). Data entered in a parameter can change the options available in the parameters following that entry.

The main menu accesses all parameters and allows for advanced frequency converter applications.

5.2 Programming Example

Here is an example for programming the frequency converter for a common application in open loop using the quick menu.

- This procedure programs the frequency converter to receive a 0-10V DC analog control signal on input terminal 53
- The frequency converter will respond by providing 6-60Hz output to the motor proportional to the input signal (0-10V DC = 6-60Hz)

Select the following parameters using the navigation keys to scroll to the titles and press [OK] after each action.

1. 3-15 Reference Resource 1

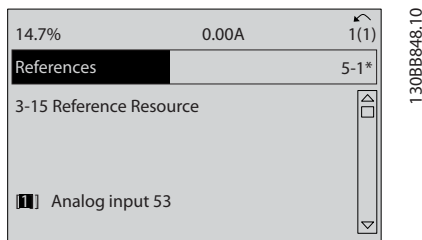

2. 3-02 Minimum Reference. Set minimum internal frequency converter reference to 0Hz. (This sets the minimum frequency converter speed at 0Hz.)

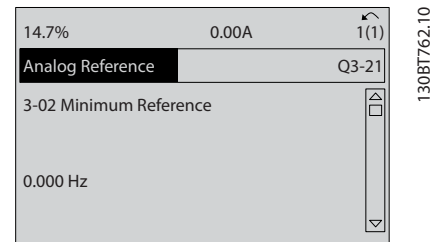

3. 3-03 Maximum Reference. Set maximum internal frequency converter reference to 60Hz. (This sets the maximum frequency converter speed at 60Hz. Note that 50/60Hz is a regional variation.)

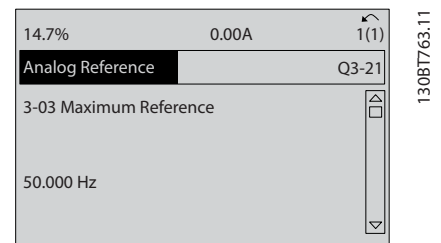

4. 6-10 Terminal 53 Low Voltage. Set minimum external voltage reference on Terminal 53 at 0V. (This sets the minimum input signal at 0V.)

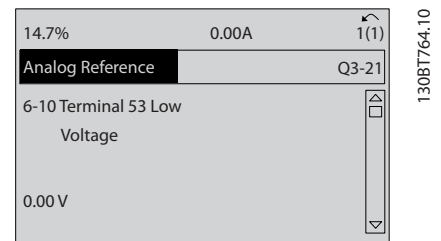

5. 6-11 Terminal 53 High Voltage. Set maximum external voltage reference on Terminal 53 at 10V. (This sets the maximum input signal at 10V.)

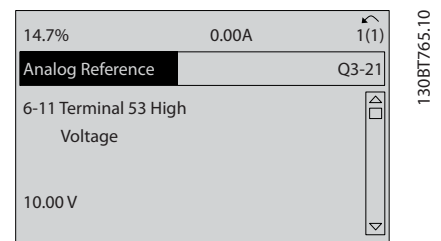

- 6-14 Terminal 53 Low Ref./Feedb. Value. Set minimum speed reference on Terminal 53 at 6Hz. (This tells the frequency converter that the minimum voltage received on Terminal 53 (0V) equals 6Hz output.)

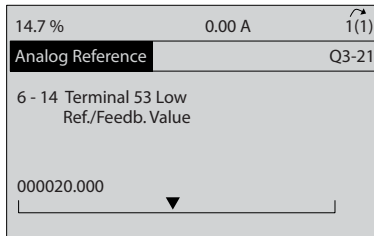

130BT773.11

- 6-15 Terminal 53 High Ref./Feedb. Value. Set maximum speed reference on Terminal 53 at 60Hz. (This tells the frequency converter that the maximum voltage received on Terminal 53 (10V) equals 60Hz output.)

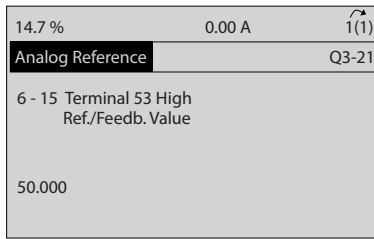

130BT774.11

With an external device providing a 0-10V control signal connected to frequency converter terminal 53, the system is now ready for operation. Note that the scroll bar on the right in the last illustration of the display is at the bottom, indicating the procedure is complete.

Illustration 5.1 shows the wiring connections used to enable this set up.

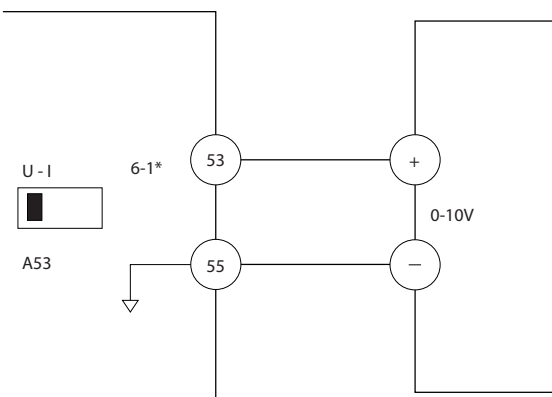

130BB482.10

Illustration 5.1 Wiring Example for External Device Providing 0-10V Control Signal (frequency converter left, external device right)

5.3 Control Terminal Programming Examples

Control terminals can be programmed.

- Each terminal has specified functions it is capable of performing
- Parameters associated with the terminal enable the function
- For proper frequency converter functioning, the control terminals must be

Wired properly

Programmed for the intended function

Receiving a signal

See Table 2.3 for control terminal parameter number and default setting. (Default setting can change based on the selection in 0-03 Regional Settings.)

The following example shows accessing Terminal 18 to see the default setting.

1. Press [Main Menu] twice, scroll to parameter group 5-** Digital In/Out and press [OK].

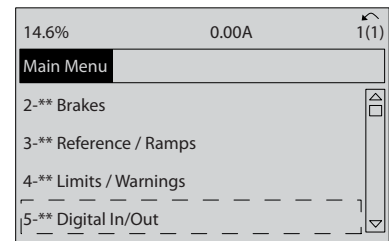

130BT768.10

2. Scroll to parameter group 5-1* Digital Inputs and press [OK].

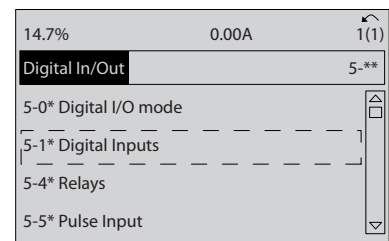

130BT769.10

3. Scroll to 5-10 Terminal 18 Digital Input. Press [OK] to access function choices. The default setting Start is shown.

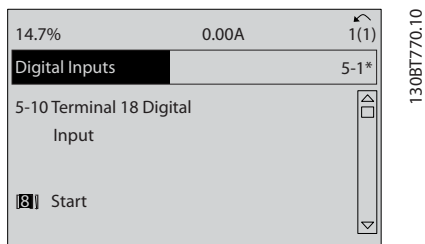

130BT770.10

5.4 International/North American Default Parameter Settings

Setting 0-03 Regional Settings to [0]International or [1] North America changes the default settings for some parameters. Table 5.1 lists those parameters that are effected.

Parameter	International default parameter value	North American default parameter value
0-03 Regional Settings	International	North America
1-20 Motor Power [kW]	See Note 1	See Note 1
1-21 Motor Power [HP]	See Note 2	See Note 2
1-22 Motor Voltage	230V/400V/575V	208V/460V/575V
1-23 Motor Frequency	50Hz	60Hz
3-03 Maximum Reference	50Hz	60Hz
3-04 Reference Function	Sum	External/Preset
4-13 Motor Speed High Limit [RPM] See Note 3 and 5	1500RPM	1800RPM
4-14 Motor Speed High Limit [Hz] See Note 4	50Hz	60Hz
4-19 Max Output Frequency	132Hz	120Hz
4-53 Warning Speed High	1500RPM	1800RPM
5-12 Terminal 27 Digital Input	Coast inverse	External interlock
5-40 Function Relay	No operation	No alarm
6-15 Terminal 53 High Ref./Feedb. Value	50	60
6-50 Terminal 42 Output	No operation	Speed 4-20mA

Parameter	International default parameter value	North American default parameter value
14-20 Reset Mode	Manual reset	Infinite auto reset

Table 5.1 International/North American Default Parameter Settings

Note 1: 1-20 Motor Power [kW] is only visible when 0-03 Regional Settings is set to [0] International.
 Note 2: 1-21 Motor Power [HP], is only visible when 0-03 Regional Settings is set to [1] North America.
 Note 3: This parameter is only visible when 0-02 Motor Speed Unit is set to [0] RPM.
 Note 4: This parameter is only visible when 0-02 Motor Speed Unit is set to [1] Hz.
 Note 5: The default value depends on the number of motor poles. For a 4 poled motor the international default value is 1500RPM and for a 2 poled motor 3000RPM. The corresponding values for North America is 1800 and 3600RPM, respectively.
 Changes made to default settings are stored and available for viewing in the quick menu along with any programming entered into parameters.

1. Press [Quick Menu].
2. Scroll to Q5 Changes Made and press [OK].

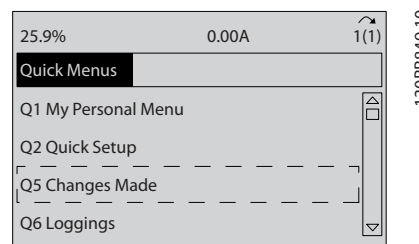

130BB849.10

3. Select Q5-2 Since Factory Setting to view all programming changes or Q5-1 Last 10 Changes for the most recent.

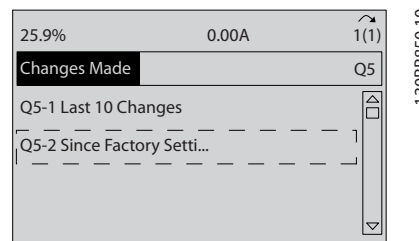

130BB850.10

5.5 Parameter Menu Structure

Establishing the correct programming for applications often requires setting functions in several related parameters.

These parameter settings provide the frequency converter with system details for the frequency converter to operate properly. System details may include such things as input and output signal types, programming terminals, minimum and maximum signal ranges, custom displays, automatic restart, and other features.

- See the LCP display to view detailed parameter programming and setting options.
- Press [Info] in any menu location to view additional details for that function.
- Press and hold [Main Menu] to enter a parameter number for direct access to that parameter.
- Details for common application set ups are provided in *6 Application Set-Up Examples*.

5.5.1 Main Menu Structure

Operation / Display	Motor Power [kW]	KTY Sensor Type	Ramp 2	Tracking Error Ramping Timeout
0-0* Basic Settings	1-20 Motor Power [kW]	1-95 KTY Thermistor Resource	3-5* Ramp 2	4-38 Tracking Error Ramping Timeout
0-01 Language	1-21 Motor Power [HP]	1-96 KTY Threshold level	3-50 Ramp 2 Type	4-39 Tracking Error After Ramping Timeout
0-02 Motor Speed Unit	1-22 Motor Voltage	1-97 KTY Threshold level	3-51 Ramp 2 Ramp up Time	4-5* Adj. Warnings
0-03 Regional Settings	1-23 Motor Frequency	1-98 ATEX ETR interpol. points freq.	3-52 Ramp 2 Ramp down Time	4-50 Warning Current Low
0-04 Operating State at Power-up (Hand)	1-24 Motor Current	1-99 ATEX ETR interpol. points current	3-55 Ramp 2 S-ramp Ratio at Accel. Start	4-51 Warning Current High
0-09 Performance Monitor	1-25 Motor Nominal Speed	2-** Brakes	3-56 Ramp 2 S-ramp Ratio at Decel. Start	4-52 Warning Speed Low
0-1* Set-up Operations	1-26 Motor Cont. Rated Torque	2-0* DC-Brake	3-57 Ramp 2 S-ramp Ratio at Decel. End	4-53 Warning Speed High
0-10 Active Set-up	1-29 Automatic Motor Adaptation (AMA)	2-00 DC Hold Current	3-6* Ramp 3	4-54 Warning Reference Low
0-11 Edit Set-up	1-30 Stator Resistance (Rs)	2-01 DC Brake Current	3-60 Ramp 3 Type	4-55 Warning Reference High
0-12 This Set-up Linked to	1-31 Rotor Resistance (Rr)	2-02 DC Braking Time	3-61 Ramp 3 Ramp up Time	4-56 Warning Feedback Low
0-13 Readout: Linked Set-ups	1-32 Stator Leakage Reactance (X1)	2-03 DC Brake Cut in Speed [RPM]	3-62 Ramp 3 Ramp down Time	4-57 Warning Feedback High
0-14 Readout: Edit Set-ups / Channel	1-33 Rotor Leakage Reactance (X2)	2-04 DC Brake Cut in Speed [Hz]	3-65 Ramp 3 S-ramp Ratio at Accel. Start	4-58 Missing Motor Phase Function
0-2* LCP Display	1-34 Rotor Leakage Reactance (X2)	2-05 Brake Energy Funct.	3-66 Ramp 3 S-ramp Ratio at Decel. Start	4-6* Speed Bypass
0-20 Display Line 1.1 Small	1-35 Main Reactance (Xh)	2-10 Brake Function	3-67 Ramp 3 S-ramp Ratio at Decel. End	4-60 Bypass Speed From [RPM]
0-21 Display Line 1.2 Small	1-36 Iron Loss Resistance (Rfe)	2-11 Brake Resistor (ohm)	3-7* Ramp 4	4-61 Bypass Speed To [RPM]
0-22 Display Line 1.3 Small	1-37 d-axis Inductance (Ld)	2-12 Brake Power Limit (kW)	3-70 Ramp 4 Type	4-62 Bypass Speed To [Hz]
0-23 Display Line 2 Large	1-40 Back EMF at 1000 RPM	2-13 Brake Power Monitoring	3-71 Ramp 4 Ramp up Time	5-** Digital In/Out
0-25 My Personal Menu	1-41 Motor Angle Offset	2-15 Brake Check	3-72 Ramp 4 Ramp down Time	5-0* Digital I/O mode
0-3* LCP Custom Readout	1-5* Load Indep. Setting	2-16 AC brake Max. Current	3-75 Ramp 4 S-ramp Ratio at Accel. Start	5-00 Digital I/O Mode
0-30 Unit for User-defined Readout	1-50 Motor Magnetising at Zero Speed	2-17 Over-voltage Control	3-76 Ramp 4 S-ramp Ratio at Decel. End	5-01 Terminal 27 Mode
0-31 Min Value of User-defined Readout	1-51 Min Speed Normal Magnetising [RPM]	2-18 Brake Check Condition	3-77 Ramp 4 S-ramp Ratio at Decel. Start	5-02 Terminal 29 Mode
0-32 Max Value of User-defined Readout	1-52 Min Speed Normal Magnetising [Hz]	2-19 Over-voltage Gain	5-1* Digital Inputs	5-10 Terminal 18 Digital Input
0-37 Display Text 1	1-53 Model Shift Frequency	2-2* Mechanical Brake	5-11 Terminal 19 Digital Input	5-11 Terminal 19 Digital Input
0-38 Display Text 2	1-54 Voltage reduction in fieldweakening	2-20 Release Brake Current	5-12 Terminal 20 Digital Input	5-12 Terminal 20 Digital Input
0-39 Display Text 3	1-55 U/f Characteristic - U	2-21 Activate Brake Speed [RPM]	5-13 Terminal 21 Digital Input	5-13 Terminal 21 Digital Input
0-4* LCP keypad	1-56 U/f Characteristic - F	2-22 Activate Brake Speed [Hz]	5-14 Terminal 22 Digital Input	5-14 Terminal 22 Digital Input
0-40 [Hand on] Key on LCP	1-58 Flystart Test Pulses Current	2-23 Activate Brake Delay	5-15 Terminal 33 Digital Input	5-15 Terminal 33 Digital Input
0-41 [Off] Key on LCP	1-6* Load Depen. Setting	2-24 Stop Delay	5-16 Terminal X30/2 Digital Input	5-16 Terminal X30/2 Digital Input
0-42 [Auto on] Key on LCP	1-60 Low Speed Load Compensation	2-25 Brake Release Time	5-17 Terminal X30/3 Digital Input	5-17 Terminal X30/3 Digital Input
0-43 [Reset] Key on LCP	1-61 High Speed Load Compensation	2-26 Torque Ref	5-18 Terminal X30/4 Digital Input	5-18 Terminal X30/4 Digital Input
0-44 [Off/Reset] Key on LCP	1-62 Slip Compensation	2-27 Torque Ramp Time	5-19 Terminal 37 Safe Stop	5-19 Terminal 37 Safe Stop
0-45 [Drive Bypass] Key on LCP	1-63 Slip Compensation Time Constant	2-28 Gain Boost Factor	5-20 Terminal X46/1 Digital Input	5-20 Terminal X46/1 Digital Input
0-5* Copy/Save	1-64 Resonance Dampening Time Constant	3-** Reference / Ramps	5-21 Terminal X46/3 Digital Input	5-21 Terminal X46/3 Digital Input
0-50 LCP Copy	1-66 Min. Current at Low Speed	3-00 Reference Range	5-22 Terminal X46/5 Digital Input	5-22 Terminal X46/5 Digital Input
0-51 Set-up Copy	1-67 Load Type	3-01 Reference/Feedback Unit	5-23 Terminal X46/7 Digital Input	5-23 Terminal X46/7 Digital Input
0-6* Password	1-68 Minimum Inertia	3-02 Minimum Reference	5-24 Terminal X46/9 Digital Input	5-24 Terminal X46/9 Digital Input
0-60 Main Menu Password	1-69 Maximum Inertia	3-03 Maximum Reference	5-25 Terminal X46/11 Digital Input	5-25 Terminal X46/11 Digital Input
0-61 Access to Main Menu w/o Password	1-7* Start Adjustments	3-04 Reference Function	5-26 Terminal X46/13 Digital Input	5-26 Terminal X46/13 Digital Input
0-65 Quick Menu Password	1-71 Start Delay	3-1* References	5-3* Digital Outputs	5-30 Terminal 27 Digital Output
0-66 Access to Quick Menu w/o Password	1-72 Start Function	3-10 Preset Reference	5-31 Terminal 29 Digital Output	5-31 Terminal 29 Digital Output
1-** Load and Motor	1-73 Flying Start	3-11 Jog Speed [Hz]	5-32 Term X30/6 Digi Out (MCB 101)	5-32 Term X30/6 Digi Out (MCB 101)
1-0* General Settings	1-74 Start Speed [RPM]	3-12 Catch up/slow Down Value	5-4* Relays	5-40 Function Relay
1-00 Configuration Mode	1-75 Start Speed [Hz]	3-13 Reference Site	5-41 On Delay, Relay	5-41 On Delay, Relay
1-01 Motor Control Principle	1-76 Start Current	3-14 Preset Relative Reference	5-42 Off Delay, Relay	5-42 Off Delay, Relay
1-02 Flux Motor Feedback Source	1-8* Stop Adjustments	3-15 Reference Resource 1	5-5* Pulse Input	5-50 Term. 29 Low Frequency
1-03 Torque Characteristics	1-80 Function at Stop	3-16 Reference Resource 2	5-51 Term. 29 High Frequency	5-51 Term. 29 High Frequency
1-04 Overload Mode	1-81 Min Speed for Function at Stop [RPM]	3-17 Reference Resource 3	5-52 Term. 29 Low Ref./Feedb. Value	5-52 Term. 29 Low Ref./Feedb. Value
1-05 Local Mode Configuration	1-82 Min Speed for Function at Stop [Hz]	3-18 Relative Scaling Reference Resource	5-53 Term. 29 High Ref./Feedb. Value	5-53 Term. 29 High Ref./Feedb. Value
1-06 Clockwise Direction	1-83 Precise Stop Function	3-19 Jog Speed [RPM]	5-54 Pulse Filter Time Constant #29	5-54 Pulse Filter Time Constant #29
1-1* Motor Selection	1-84 Precise Stop Counter Value	3-4* Ramp 1	5-55 Term. 33 Low Frequency	5-55 Term. 33 Low Frequency
1-10 Motor Construction	1-85 Precise Stop Speed Compensation Delay	3-40 Ramp 1 Type	5-56 Term. 33 High Frequency	5-56 Term. 33 High Frequency
1-2* Motor Data	1-9* Motor Temperature	3-41 Ramp 1 Ramp up Time	5-57 Term. 33 Low Ref./Feedb. Value	5-57 Term. 33 Low Ref./Feedb. Value
	1-90 Motor Thermal Protection	3-42 Ramp 1 Ramp Down Time	5-58 Term. 33 High Ref./Feedb. Value	5-58 Term. 33 High Ref./Feedb. Value
	1-91 Motor External Fan	3-43 Ramp 1 S-ramp Ratio at Accel. Start		
	1-93 Thermistor Resource	3-44 Ramp 1 S-ramp Ratio at Decel. End		
	1-94 ATEX ETR cur./lim. speed reduction	3-45 Ramp 1 S-ramp Ratio at Accel. Start		
		3-46 Ramp 1 S-ramp Ratio at Decel. Start		
		3-47 Ramp 1 S-ramp Ratio at Decel. End		
		3-48 Ramp 1 S-ramp Ratio at Decel. End		

13-10 Comparator Operand	14-74 Leg. Ext. Status Word	15-92 Defined Parameters	16-72 Counter A	30-03 Wobble Delta Freq. Scaling Resource
13-11 Comparator Operator	14-8* Options	15-93 Modified Parameters	16-73 Counter B	30-04 Wobble Jump Frequency [Hz]
13-12 Comparator Value	14-80 Option Supplied by External 24VDC	15-98 Drive Identification	16-74 Prec. Stop Counter	30-05 Wobble Jump Frequency [%]
13-2* Timers	14-89 Option Detection	15-99 Parameter Metadata	16-75 Analog In X30/11	30-06 Wobble Jump Time
13-4* Logic Rules	14-9* Fault Settings	16-0* Data Readouts	16-76 Analog In X30/12	30-07 Wobble Sequence Time
13-40 Logic Rule Boolean 1	14-90 Fault Level	16-0* General Status	16-77 Analog Out X30/8 [mA]	30-08 Wobble Up/Down Time
13-41 Logic Rule Operator 1	15-0* Drive Information	16-00 Control Word	16-78 Analog Out X45/1 [mA]	30-09 Wobble Random Function
13-42 Logic Rule Boolean 2	15-0* Operating Data	16-01 Reference [Unit]	16-79 Analog Out X45/3 [mA]	30-10 Wobble Ratio
13-43 Logic Rule Operator 2	15-00 Operating Hours	16-02 Reference %	16-8* Fieldbus & FC Port	30-11 Wobble Random Ratio Max.
13-44 Logic Rule Boolean 3	15-01 Running Hours	16-03 Status Word	16-80 Fieldbus CTW 1	30-12 Wobble Random Ratio Min.
13-5* States	15-02 kWh Counter	16-05 Main Actual Value [%]	16-82 Fieldbus CTW 1	30-19 Wobble Delta Freq. Scaled
13-51 SL Controller Event	15-03 Power Up's	16-09 Custom Readout	16-84 Comm. Option STW	30-2* Adv. Start Adjust
13-52 SL Controller Action	15-04 Over Temp's	16-1* Motor Status	16-85 FC Port CTW 1	30-20 High Starting Torque Time [s]
14** Special Functions	15-05 Over Volt's	16-10 Power [kW]	16-86 FC Port REF 1	30-21 High Starting Torque Current [%]
14-0* Inverter Switching	15-06 Reset kWh Counter	16-11 Power [hp]	16-9* Diagnosis Readouts	30-22 Locked Rotor Protection
14-00 Switching Pattern	15-07 Reset Running Hours Counter	16-12 Motor Voltage	16-90 Alarm Word	30-8* Compatibility (0)
14-01 Switching Frequency	15-1* Data Log Settings	16-13 Frequency	16-91 Alarm Word 2	30-80 d-axis Inductance (Ld)
14-03 Overmodulation	15-10 Logging Source	16-14 Motor Current	16-92 Warning Word	30-81 Brake Resistor (ohm)
14-04 PWM Random	15-11 Logging Interval	16-15 Frequency [%]	16-93 Warning Word 2	30-83 Speed PID Proportional Gain
14-06 Dead Time Compensation	15-12 Trigger Event	16-16 Torque [Nm]	16-94 Ext. Status Word	30-84 Process PID Proportional Gain
14-1* Mains On/Off	15-13 Logging Mode	16-17 Speed [RPM]	17-0* Feedback Option	31-0* Bypass Option
14-10 Mains Failure	15-14 Samples Before Trigger	16-18 Motor Thermal	17-1* Inc. Enc. Interface	31-00 Bypass Mode
14-11 Mains Voltage at Mains Fault	15-2* Historic Log	16-19 kTY sensor temperature	17-10 Signal Type	31-01 Bypass Start Time Delay
14-12 Function at Mains Imbalance	15-20 Historic Log: Event	16-20 Motor Angle	17-11 Resolution (PPR)	31-02 Bypass Trip Time Delay
14-13 Mains Failure Step Factor	15-21 Historic Log: Value	16-21 Torque [%] High Res.	17-2* Abs. Enc. Interface	31-03 Test Mode Activation
14-14 Kin. Backup Time Out	15-22 Historic Log: Time	16-22 Torque [%]	17-20 Protocol Selection	31-10 Bypass Status Word
14-2* Trip Reset	15-3* Fault Log	16-25 Torque [Nm] High	17-21 Resolution (Positions/Rev)	31-11 Bypass Running Hours
14-20 Reset Mode	15-30 Fault Log: Error Code	16-3* Drive Status	17-24 SSI Data Length	31-19 Remote Bypass Activation
14-21 Automatic Restart Time	15-31 Fault Log: Value	16-30 DC Link Voltage	17-25 Clock Rate	32-0* Encoder 2
14-22 Operation Mode	15-32 Fault Log: Time	16-32 Brake Energy / s	17-26 SSI Data Format	32-00 Incremental Signal Type
14-23 Typecode Setting	15-4* Drive Identification	16-33 Brake Energy / 2 min	17-34 HIPERFACE Baudrate	32-01 Incremental Resolution
14-24 Trip Delay at Current Limit	15-40 FC Type	16-34 Heatsink Temp.	17-5* Resolver Interface	32-02 Absolute Protocol
14-25 Trip Delay at Torque Limit	15-41 Power Section	16-35 Inverter Thermal	17-50 Poles	32-03 Absolute Resolution
14-26 Trip Delay at Inverter Fault	15-42 Voltage	16-36 Inv. Nom. Current	17-51 Input Voltage	32-04 Absolute Encoder Baudrate X55
14-28 Production Settings	15-43 Software Version	16-37 Inv. Max. Current	17-52 Input Frequency	32-05 Absolute Encoder Data Length
14-29 Service Code	15-44 Ordered Typecode String	16-38 SL Controller State	17-53 Transformation Ratio	32-06 Absolute Encoder Clock Frequency
14-3* Current Limit Ctrl.	15-45 Actual Typecode String	16-39 Control Card Temp.	17-54 Resolver Interface	32-07 Absolute Encoder Clock Generation
14-30 Current Lim Ctrl, Proportional Gain	15-46 Frequency Converter Ordering No	16-40 Logging Buffer Full	17-6* Monitoring and App.	32-08 Absolute Encoder Cable Length
14-31 Current Lim Ctrl, Integration Time	15-47 Power Card Ordering No	16-41 LCP Bottom Statusline	17-60 Feedback Direction	32-09 Encoder Monitoring
14-32 Current Lim Ctrl, Filter Time	15-48 LCP Id No	16-49 Current Fault Source	18-0* Data Readouts 2	32-10 Rotational Direction
14-35 Stall Protection	15-49 SW ID Control Card	16-5* Ref. & Feedsb.	18-3* Analog Readouts	32-11 User Unit Denominator
14-4* Energy Optimising	15-50 SW ID Power Card	16-50 External Reference	18-36 Analog Input X48/2 [mA]	32-12 User Unit Numerator
14-40 VT Level	15-51 Frequency Converter Serial Number	16-51 Pulse Reference	18-37 Temp. Input X48/4	32-13 Enc.2 Control
14-41 AEO Minimum Magnetisation	15-52 Power Card Serial Number	16-52 Feedback [Unit]	18-38 Temp. Input X48/7	32-14 Enc.2 node ID
14-42 Minimum AEO Frequency	15-59 CSV Filename	16-53 Digi Pot Reference	18-39 Temp. Input X48/10	32-3* Encoder 1
14-43 Motor Cosphi	15-6* Option Ident	16-57 Feedback [RPM]	18-6* Inputs & Outputs 2	32-31 Incremental Signal Type
14-5* Environment	15-60 Option Mounted	16-6* Inputs & Outputs	18-60 Digital Input 2	32-32 Absolute Protocol
14-50 RFI Filter	15-61 Option SW Version	16-60 Digital Input	18-66 Analog Input 53	32-33 Absolute Resolution
14-51 DC Link Compensation	15-62 Option Ordering No	16-61 Terminal 53 Switch Setting	16-64 Analog Input 54	32-35 Absolute Encoder Data Length
14-52 Fan Control	15-63 Option Serial No	16-62 Analog Input 53	16-65 Analog Input 54	32-36 Absolute Encoder Clock Frequency
14-53 Fan Monitor	15-70 Option in Slot A	16-64 Analog Input 54	16-66 Digital Output 42 [mA]	32-37 Absolute Encoder Clock Generation
14-55 Output Filter	15-71 Slot A Option SW Version	16-65 Analog Input 54	16-67 Freq. Input #29 [Hz]	32-38 Absolute Encoder Cable Length
14-56 Capacitance Output Filter	15-72 Option in Slot B	16-66 Digital Output [bin]	16-68 Freq. Input #33 [Hz]	32-39 Encoder Monitoring
14-57 Inductance Output Filter	15-73 Slot B Option SW Version	16-67 Freq. Input #29 [Hz]	16-69 Pulse Output #27 [Hz]	32-40 Encoder Termination
14-59 Actual Number of Inverter Units	15-74 Option in Slot C0	16-68 Freq. Input #33 [Hz]	16-70 Pulse Output #29 [Hz]	32-43 Enc.1 Control
14-7* Compatibility	15-75 Slot C0 Option SW Version	16-69 Pulse Output #27 [Hz]	16-71 Relay Output [bin]	
14-72 Legacy Alarm Word	15-76 Option in Slot C1	16-70 Pulse Output #29 [Hz]		
14-73 Legacy Warning Word	15-9* Parameter Info			

32-44 Enc.1 node ID	33-00 Force HOME	33-46 Target Window Limit/Value	33-95 X60 MCO RS485 serial baud rate	34-60 Synchronizing Status
32-45 Enc.1 CAN guard	33-01 Zero Point Offset from Home Pos.	33-47 Size of Target Window	34-** MCO Data Readouts	34-61 Axis Status
32-5* Feedback Source	33-02 Ramp for Home Motion	33-5* I/O Configuration	34-0* PCD Write Par.	34-62 Program Status
32-50 Source Slave	33-03 Velocity of Home Motion	33-50 Terminal X57/1 Digital Input	34-01 PCD 1 Write to MCO	34-64 MCO 302 Status
32-51 MCO 302 Last Will	33-04 Behaviour during HomeMotion	33-51 Terminal X57/2 Digital Input	34-02 PCD 2 Write to MCO	34-65 MCO 302 Control
32-52 Source Master	33-1* Synchronization	33-52 Terminal X57/3 Digital Input	34-03 PCD 3 Write to MCO	34-7* Diagnosis readouts
32-6* PID Controller	33-10 Sync Factor Master	33-53 Terminal X57/4 Digital Input	34-04 PCD 4 Write to MCO	34-70 MCO Alarm Word 1
32-60 Proportional factor	33-11 Sync Factor Slave	33-54 Terminal X57/5 Digital Input	34-05 PCD 5 Write to MCO	34-71 MCO Alarm Word 2
32-61 Derivative factor	33-12 Position Offset for Synchronization	33-55 Terminal X57/6 Digital Input	34-06 PCD 6 Write to MCO	35-** Sensor Input Option
32-62 Integral factor	33-13 Accuracy Window for Position Sync.	33-56 Terminal X57/7 Digital Input	34-07 PCD 7 Write to MCO	35-0* Temp. Input Mode
32-63 Limit Value for Integral Sum	33-14 Relative Slave Velocity Limit	33-57 Terminal X57/8 Digital Input	34-08 PCD 8 Write to MCO	35-00 Term. X48/4 Temp. Unit
32-64 PID Bandwidth	33-15 Marker Number for Master	33-58 Terminal X57/9 Digital Input	34-09 PCD 9 Write to MCO	35-01 Term. X48/4 Input Type
32-65 Velocity Feed-Forward	33-16 Marker Number for Slave	33-59 Terminal X57/10 Digital Input	34-10 PCD 10 Write to MCO	35-02 Term. X48/7 Temp. Unit
32-66 Acceleration Feed-Forward	33-17 Master Marker Distance	33-60 Terminal X59/1 and X59/2 Mode	34-2* PCD Read Par.	35-03 Term. X48/7 Input Type
32-67 Max. Tolerated Position Error	33-18 Slave Marker Distance	33-61 Terminal X59/1 Digital Input	34-21 PCD 1 Read from MCO	35-04 Term. X48/10 Temp. Unit
32-68 Reverse Behavior for Slave	33-19 Master Marker Type	33-62 Terminal X59/2 Digital Input	34-22 PCD 2 Read from MCO	35-05 Term. X48/10 Input Type
32-69 Sampling Time for PID Control	33-20 Slave Marker Type	33-63 Terminal X59/1 Digital Output	34-23 PCD 3 Read from MCO	35-06 Temperature Sensor Alarm Function
32-70 Scan Time for Profile Generator	33-21 Master Marker Tolerance Window	33-64 Terminal X59/2 Digital Output	34-24 PCD 4 Read from MCO	35-1* Temp. Input X48/4
32-71 Size of the Control Window (Activation)	33-22 Slave Marker Tolerance Window	33-65 Terminal X59/3 Digital Output	34-25 PCD 5 Read from MCO	35-14 Term. X48/4 Filter Time Constant
32-72 Size of the Control Window (Deactiv.)	33-23 Start Behaviour for Marker Sync	33-66 Terminal X59/4 Digital Output	34-26 PCD 6 Read from MCO	35-15 Term. X48/4 Temp. Monitor
32-73 Integral limit filter time	33-24 Marker Number for Fault	33-67 Terminal X59/5 Digital Output	34-27 PCD 7 Read from MCO	35-16 Term. X48/4 Low Temp. Limit
32-74 Position error filter time	33-25 Marker Number for Ready	33-68 Terminal X59/6 Digital Output	34-28 PCD 8 Read from MCO	35-17 Term. X48/4 High Temp. Limit
32-8* Velocity & Accel.	33-26 Velocity Filter	33-69 Terminal X59/7 Digital Output	34-29 PCD 9 Read from MCO	35-2* Temp. Input X48/7
32-80 Maximum Velocity (Encoder)	33-27 Offset Filter Time	33-70 Terminal X59/8 Digital Output	34-30 PCD 10 Read from MCO	35-24 Term. X48/7 Filter Time Constant
32-81 Shortest Ramp	33-28 Marker Filter Configuration	33-8* Global Parameters	34-4* Inputs & Outputs	35-25 Term. X48/7 Temp. Monitor
32-82 Ramp Type	33-29 Filter Time for Marker Filter	33-80 Activated Program Number	34-40 Digital Inputs	35-26 Term. X48/7 Low Temp. Limit
32-83 Velocity Resolution	33-30 Maximum Marker Correction	33-81 Power-up State	34-41 Digital Outputs	35-27 Term. X48/7 High Temp. Limit
32-84 Default Velocity	33-31 Synchronisation Type	33-82 Drive Status Monitoring	34-5* Process Data	35-3* Temp. Input X48/10
32-85 Default Acceleration	33-32 Feed Forward Velocity Adaptation	33-83 Behaviour afterError	34-50 Actual Position	35-34 Term. X48/10 Filter Time Constant
32-86 Acc. up for limited jerk	33-33 Velocity Filter Window	33-84 Behaviour afterEsc.	34-51 Commanded Position	35-35 Term. X48/10 Temp. Monitor
32-87 Acc. down for limited jerk	33-34 Slave Marker filter time	33-85 MCO Supplied by External 24VDC	34-52 Actual Master Position	35-36 Term. X48/10 Low Temp. Limit
32-88 Dec. up for limited jerk	33-4* Limit Handling	33-86 Terminal at alarm	34-53 Slave Index Position	35-37 Term. X48/10 High Temp. Limit
32-89 Dec. down for limited jerk	33-40 Behaviour at End Limit Switch	33-87 Terminal state at alarm	34-54 Master Index Position	35-4* Analog Input X48/2
32-9* Development	33-41 Negative Software End Limit	33-9* MCO Port Settings	34-55 Curve Position	35-42 Term. X48/2 Low Current
32-90 Debug Source	33-42 Positive Software End Limit	33-90 X62 MCO CAN node ID	34-56 Track Error	35-43 Term. X48/2 High Current
33-** MCO Actv. Settings	33-43 Negative Software End Limit Active	33-91 X62 MCO CAN baud rate	34-57 Synchronizing Error	35-44 Term. X48/2 Low Ref./Feedb. Value
33-0* Home Motion	33-44 Positive Software End Limit Active	33-94 X60 MCO RS485 serial termination	34-58 Actual Velocity	35-45 Term. X48/2 High Ref./Feedb. Value
	33-45 Time in Target Window		34-59 Actual Master Velocity	35-46 Term. X48/2 Filter Time Constant

5.6 Remote Programming with MCT 10 Set-up Software

Danfoss has a software program available for developing, storing, and transferring frequency converter programming. The MCT 10 Set-up Software allows the user to connect a PC to the frequency converter and perform live programming rather than using the LCP. Also, all frequency converter programming can be done off-line and simply downloaded into frequency converter. Or the entire frequency converter profile can be loaded onto the PC for back up storage or analysis.

The USB connector or RS-485 terminal are available for connecting to the frequency converter.

MCT 10 Set-up Software is available for free download at www.VLT-software.com. A CD is also available by requesting part number 130B1000. A user's manual provides detailed operation instructions.

6 Application Set-Up Examples

6.1 Introduction

NOTE

A jumper wire may be required between terminal 12 (or 13) and terminal 27 for the frequency converter to operate when using factory default programming values. See 2.4.1.1 *Jumper Terminals 12 and 27* for details.

The examples in this section are intended as a quick reference for common applications.

- Parameter settings are the regional default values unless otherwise indicated (selected in 0-03 *Regional Settings*)
- Parameters associated with the terminals and their settings are shown next to the drawings
- Where switch settings for analog terminals A53 or A54 are required, these are also shown

6

		Parameters	
FC		Function	Setting
+24 V	12		
+24 V	13		
D IN	18	1-29 Automatic Motor Adaptation (AMA)	[1] Enable complete AMA
D IN	19		
COM	20		
D IN	27	5-12 Terminal 27 Digital Input	[0] No operation
D IN	29		
D IN	32		
D IN	33		
D IN	37		
+10 V	50		
A IN	53		
A IN	54		
COM	55		
A OUT	42		
COM	39		
		* = Default Value	
		Notes/comments: Parameter group 1-2* must be set according to motor	

6.2 Application Examples

		Parameters	
FC		Function	Setting
+24 V	12		
+24 V	13		
D IN	18		
D IN	19		
COM	20		
D IN	27	1-29 Automatic Motor Adaptation (AMA)	[1] Enable complete AMA
D IN	29		
D IN	32		
D IN	33		
D IN	37		
+10 V	50		
A IN	53		
A IN	54		
COM	55		
A OUT	42		
COM	39		
		* = Default Value	
		Notes/comments: Parameter group 1-2* must be set according to motor	

Table 6.1 AMA with T27 Connected

Table 6.2 AMA without T27 Connected

		Parameters	
FC		Function	Setting
+24 V	12		
+24 V	13		
D IN	18		
D IN	19		
COM	20		
D IN	27		
D IN	29		
D IN	32		
D IN	33		
D IN	37		
+10 V	50		
A IN	53	6-10 Terminal 53 Low Voltage	0.07V*
A IN	54	6-11 Terminal 53 High Voltage	10V*
COM	55		
A OUT	42	6-14 Terminal 53 Low Ref./Feedb. Value	ORPM
COM	39	6-15 Terminal 53 High Ref./Feedb. Value	1500RPM
		* = Default Value	
		Notes/comments:	

Table 6.3 Analog Speed Reference (Voltage)

		Parameters	
FC		Function	Setting
+24 V	12		
+24 V	13		
D IN	18	6-12 Terminal 53	4mA*
D IN	19	Low Current	
COM	20	6-13 Terminal 53	20mA*
D IN	27	High Current	
D IN	29	6-14 Terminal 53	ORPM
D IN	32	Low Ref./Feedb.	
D IN	33	Value	
D IN	37	6-15 Terminal 53	1500RPM
+10 V	50	High Ref./Feedb.	
A IN	53	Value	
A IN	54	* = Default Value	
COM	55	Notes/comments:	
A OUT	42		
COM	39		

130BB927.10

4 - 20mA

U - I

A53

Table 6.4 Analog Speed Reference (Current)

		Parameters	
FC		Function	Setting
+24 V	12		
+24 V	13		
D IN	18	5-10 Terminal 18	[9] Latched
D IN	19	Digital Input	Start
COM	20	5-12 Terminal 27	[6] Stop
D IN	27	Digital Input	Inverse
D IN	29	* = Default Value	
D IN	32	Notes/comments:	
D IN	33		
D IN	37		
+10 V	50		
A IN	53		
A IN	54		
COM	55		
A OUT	42		
COM	39		

130BB803.10

* = Default Value

Notes/comments:
If 5-12 Terminal 27 Digital Input is set to [0] No operation, a jumper wire to terminal 27 is not needed.

Table 6.6 Pulse Start/Stop

		Parameters	
FC		Function	Setting
+24 V	12		
+24 V	13		
D IN	18	5-10 Terminal 18	[8] Start*
D IN	19	Digital Input	
COM	20	5-12 Terminal 27	[0] No
D IN	27	Digital Input	operation
D IN	29	5-19 Terminal 37	[1] Safe Stop
D IN	32	Safe Stop	Alarm
D IN	33	* = Default Value	
D IN	37	Notes/comments:	
+10	50		
A IN	53		
A IN	54		
COM	55		
A OUT	42		
COM	39		

130BB802.10

* = Default Value

Notes/comments:
If 5-12 Terminal 27 Digital Input is set to [0] No operation, a jumper wire to terminal 27 is not needed.

Table 6.5 Start/Stop Command with Safe Stop

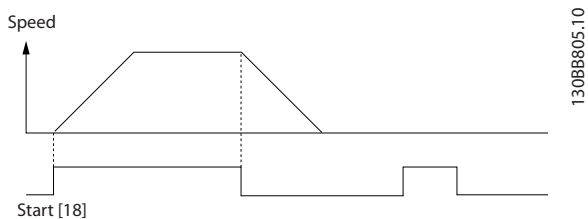
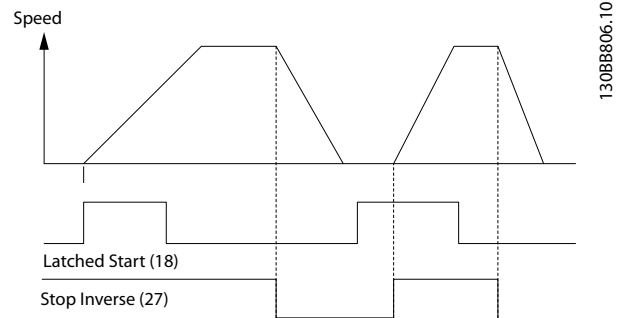

6

		Parameters	
FC		Function	Setting
+24 V	12	5-10 Terminal 18 <i>Digital Input</i>	[8] Start
+24 V	13		
D IN	18		
D IN	19		
COM	20	5-11 Terminal 19 <i>Digital Input</i>	[10] Reversing*
D IN	27		
D IN	29		
D IN	32	5-12 Terminal 27 <i>Digital Input</i>	[0] No operation
D IN	33		
D IN	37	5-14 Terminal 32 <i>Digital Input</i>	[16] Preset ref bit 0
+10 V	50	5-15 Terminal 33 <i>Digital Input</i>	[17] Preset ref bit 1
A IN	53	3-10 Preset <i>Reference</i>	
A IN	54		
COM	55		
A OUT	42		
COM	39		
		Preset ref. 0	25%
		Preset ref. 1	50%
		Preset ref. 2	75%
		Preset ref. 3	100%
		* = Default Value	
		Notes/comments:	

Table 6.7 Start/Stop with Reversing and 4 Preset Speeds

		Parameters	
FC		Function	Setting
+24 V	12	5-11 Terminal 19 <i>Digital Input</i>	[1] Reset
+24 V	13		
D IN	18		
D IN	19		
COM	20	* = Default Value	
D IN	27	Notes/comments:	
D IN	29		
D IN	32		
D IN	33		
D IN	37		
+10 V	50		
A IN	53		
A IN	54		
COM	55		
A OUT	42		
COM	39		

Table 6.8 External Alarm Reset

		Parameters		
FC		Function	Setting	
+24 V	12	6-10 Terminal 53 <i>Low Voltage</i>	0.07V*	
+24 V	13			
D IN	18			
D IN	19			
COM	20		6-11 Terminal 53 <i>High Voltage</i>	10V*
D IN	27		6-14 Terminal 53 <i>Low Ref./Feedb. Value</i>	0RPM
D IN	29			
D IN	32			
D IN	33			
D IN	37	6-15 Terminal 53 <i>High Ref./Feedb. Value</i>	1500RPM	
+10 V	50	* = Default Value		
A IN	53	Notes/comments:		
A IN	54			
COM	55			
A OUT	42			
COM	39			

Table 6.9 Speed Reference (using a manual potentiometer)

		Parameters	
FC		Function	Setting
+24 V	12	5-10 Terminal 18 <i>Digital Input</i>	[8] Start*
+24 V	13		
D IN	18		
D IN	19		
COM	20	5-12 Terminal 27 <i>Digital Input</i>	[19] Freeze Reference
D IN	27	5-13 Terminal 29 <i>Digital Input</i>	[21] Speed Up
D IN	29		
D IN	32	5-14 Terminal 32 <i>Digital Input</i>	[22] Speed Down
D IN	33		
D IN	37	* = Default Value	
+10 V	50	Notes/comments:	
A IN	53		
A IN	54		
COM	55		
A OUT	42		
COM	39		

Table 6.10 Speed Up/Down

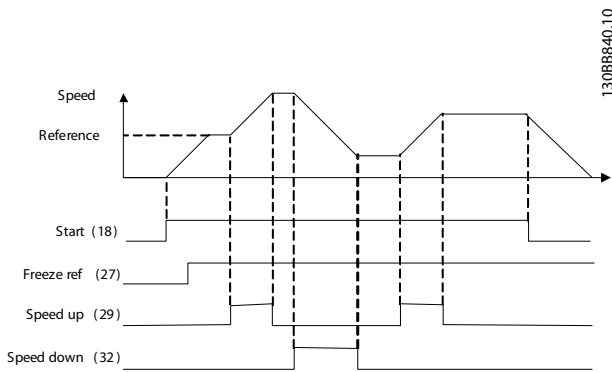

		Parameters	
		Function	Setting
FC			
+24 V	120		
+24 V	130		
D IN	180	8-30 Protocol	FC*
D IN	190	8-31 Address	1*
COM	200	8-32 Baud Rate	9600*
D IN	270	* = Default Value	
D IN	290	Notes/comments:	
D IN	320	Select protocol, address and baud rate in the above mentioned parameters.	
D IN	330		
D IN	370		
+10 V	500		
A IN	530		
A IN	540		
COM	550		
A OUT	420		
COM	390		
R1	010		
	020		
	030		
R2	040		
	050		
	060		
	610		
	680		
	690		

Table 6.11 RS-485 Network Connection

CAUTION

Thermistors must use reinforced or double insulation to meet PELV insulation requirements.

		Parameters	
		Function	Setting
FC			
+24 V	120		
+24 V	130		
D IN	180	1-90 Motor Thermal Protection	[2] Thermistor trip
D IN	190		
COM	200		
D IN	270	1-93 Thermistor Source	[1] Analog input 53
D IN	290		
D IN	320		
D IN	330		
D IN	370		
+10 V	500	* = Default Value	
A IN	530	Notes/comments:	
A IN	540	If only a warning is desired, 1-90 Motor Thermal Protection should be set to [1] Thermistor warning.	
COM	550		
A OUT	420		
COM	390		
U - I			
A53			

Table 6.12 Motor Thermistor

6

		Parameters	
FC		Function	Setting
+24 V	12	4-30 Motor Feedback Loss Function	[1] Warning
+24 V	13	4-31 Motor Feedback Speed Error	100RPM
D IN	18	4-32 Motor Feedback Loss Timeout	5 sec
D IN	19	7-00 Speed PID Feedback Source	[2] MCB 102
COM	20	17-11 Resolution (PPR)	1024*
D IN	27	13-00 SL Controller Mode	[1] On
D IN	29	13-01 Start Event	[19] Warning
D IN	32	13-02 Stop Event	[44] Reset key
D IN	33	13-10 Comparator Operand	[21] Warning no.
D IN	37	13-11 Comparator Operator	[1] ≈*
+10 V	50	13-12 Comparator Value	90
A IN	53	13-51 SL Controller Event	[22] Comparator 0
A IN	54	13-52 SL Controller Action	[32] Set digital out A low
COM	55	5-40 Function Relay	[80] SL digital output A
A OUT	42	* = Default Value	
COM	39	Notes/comments: If the limit in the feedback monitor is exceeded, Warning 90 will be issued. The SLC monitors Warning 90 and in the case that Warning 90 becomes TRUE then Relay 1 is triggered. External equipment may then indicate that service may be required. If the feedback error goes below the limit again within 5 sec. then the drive continues and the warning disappears. But Relay 1 will still be triggered until [Reset] on the LCP.	

		Parameters	
FC		Function	Setting
+24 V	12	5-40 Function Relay	[32] Mech. brake ctrl.
+24 V	13	5-10 Terminal 18 Digital Input	[8] Start*
D IN	18	5-11 Terminal 19 Digital Input	[11] Start reversing
D IN	19	1-71 Start Delay	0.2
COM	20	1-72 Start Function	[5] VVC+/FLUX Clockwise
D IN	27	1-76 Start Current	Im,n
D IN	29	2-20 Release Brake Current	App. dependent
D IN	32	2-21 Activate Brake Speed [RPM]	Half of nominal slip of the motor
D IN	33	* = Default Value	
D IN	37	Notes/comments:	

Table 6.14 Mechanical Brake Control

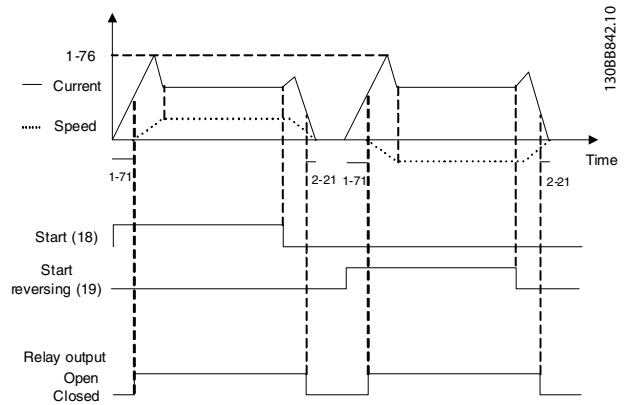

Table 6.13 Using SLC to Set a Relay

7 Status Messages

7.1 Status Display

When the frequency converter is in status mode, status messages are generated automatically from within the frequency converter and appear in the bottom line of the display (see *Illustration 7.1.*)

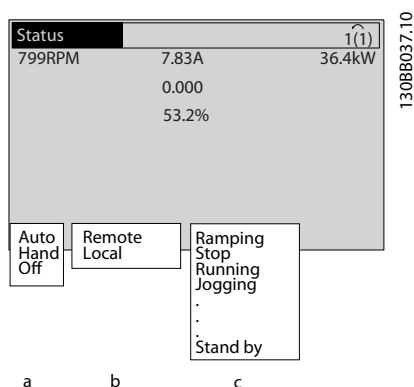

Illustration 7.1 Status Display

- The first word on the status line indicates where the stop/start command originates.
- The second word on the status line indicates where the speed control originates.
- The last part of the status line gives the present frequency converter status. These show the operational mode the frequency converter is in.

NOTE

In auto/remote mode, the frequency converter requires external commands to execute functions.

7.2 Status Message Definitions Table

The next three tables define the meaning of the status message display words.

	Operation mode
Off	The frequency converter does not react to any control signal until [Auto On] or [Hand On] is pressed.
Auto On	The frequency converter is controlled from the control terminals and/or the serial communication.
Hand On	The frequency converter can be controlled by the navigation keys on the LCP. Stop commands, reset, reversing, DC brake, and other signals applied to the control terminals can override local control.

	Reference site
Remote	The speed reference is given from external signals, serial communication, or internal preset references.
Local	The frequency converter uses [Hand On] control or reference values from the LCP.

	Operation status
AC Brake	AC Brake was selected in 2-10 Brake Function. The AC brake over-magnetizes the motor to achieve a controlled slow down.
AMA finish OK	Automatic motor adaptation (AMA) was carried out successfully.
AMA ready	AMA is ready to start. Press [Hand On] to start.
AMA running	AMA process is in progress.
Braking	The brake chopper is in operation. Generative energy is absorbed by the brake resistor.
Braking max.	The brake chopper is in operation. The power limit for the brake resistor defined in 2-12 Brake Power Limit (kW) is reached.
Coast	<ul style="list-style-type: none"> Coast inverse was selected as a function for a digital input (parameter group 5-1*). The corresponding terminal is not connected. Coast activated by serial communication
Ctrl. Ramp-down	Control Ramp-down was selected in 14-10 Mains Failure. <ul style="list-style-type: none"> The mains voltage is below the value set in 14-11 Mains Voltage at Mains Fault at mains fault The frequency converter ramps down the motor using a controlled ramp down

7

	Operation status
Current High	The frequency converter output current is above the limit set in <i>4-51 Warning Current High</i> .
Current Low	The frequency converter output current is below the limit set in <i>4-52 Warning Speed Low</i> .
DC Hold	DC hold is selected in <i>1-80 Function at Stop</i> and a stop command is active. The motor is held by a DC current set in <i>2-00 DC Hold/Preheat Current</i> .
DC Stop	The motor is held with a DC current (<i>2-01 DC Brake Current</i>) for a specified time (<i>2-02 DC Braking Time</i>). <ul style="list-style-type: none"> DC Brake is activated in <i>2-03 DC Brake Cut In Speed [RPM]</i> and a Stop command is active. DC Brake (inverse) is selected as a function for a digital input (parameter group 5-1*). The corresponding terminal is not active. The DC Brake is activated via serial communication.
Feedback high	The sum of all active feedbacks is above the feedback limit set in <i>4-57 Warning Feedback High</i> .
Feedback low	The sum of all active feedbacks is below the feedback limit set in <i>4-56 Warning Feedback Low</i> .
Freeze output	The remote reference is active which holds the present speed. <ul style="list-style-type: none"> Freeze output was selected as a function for a digital input (Group 5-1*). The corresponding terminal is active. Speed control is only possible via the terminal functions speed up and speed down. Hold ramp is activated via serial communication.
Freeze output request	A freeze output command has been given, but the motor will remain stopped until a run permissive signal is received.
Freeze ref.	<i>Freeze Reference</i> was chosen as a function for a digital input (parameter group 5-1*). The corresponding terminal is active. The frequency converter saves the actual reference. Changing the reference is now only possible via terminal functions speed up and speed down.
Jog request	A jog command has been given, but the motor will be stopped until a run permissive signal is received via a digital input.

	Operation status
Jogging	The motor is running as programmed in <i>3-19 Jog Speed [RPM]</i> . <ul style="list-style-type: none"> <i>Jog</i> was selected as function for a digital input (parameter group 5-1*). The corresponding terminal (e.g. Terminal 29) is active. The Jog function is activated via the serial communication. The Jog function was selected as a reaction for a monitoring function (e.g. No signal). The monitoring function is active.
Motor check	In <i>1-80 Function at Stop, Motor Check</i> was selected. A stop command is active. To ensure that a motor is connected to the frequency converter, a permanent test current is applied to the motor.
OVC control	<i>Overvoltage</i> control was activated in <i>2-17 Overvoltage Control</i> . The connected motor is supplying the frequency converter with generative energy. The overvoltage control adjusts the V/Hz ratio to run the motor in controlled mode and to prevent the frequency converter from tripping.
PowerUnit Off	(For frequency converters with an external 24V power supply installed only.) Mains supply to the frequency converter is removed, but the control card is supplied by the external 24V.
Protection md	Protection mode is active. The unit has detected a critical status (an overcurrent or overvoltage). <ul style="list-style-type: none"> To avoid tripping, switching frequency is reduced to 4kHz. If possible, protection mode ends after approximately 10sec. Protection mode can be restricted in <i>14-26 Trip Delay at Inverter Fault</i>
QStop	The motor is decelerating using <i>3-81 Quick Stop Ramp Time</i> . <ul style="list-style-type: none"> <i>Quick stop inverse</i> was chosen as a function for a digital input (parameter group 5-1*). The corresponding terminal is not active. The quick stop function was activated via serial communication.
Ramping	The motor is accelerating/decelerating using the active Ramp Up/Down. The reference, a limit value or a standstill is not yet reached.
Ref. high	The sum of all active references is above the reference limit set in <i>4-55 Warning Reference High</i> .
Ref. low	The sum of all active references is below the reference limit set in <i>4-54 Warning Reference Low</i> .

	Operation status
Run on ref.	The frequency converter is running in the reference range. The feedback value matches the setpoint value.
Run request	A start command has been given, but the motor is stopped until a run permissive signal is received via digital input.
Running	The motor is driven by the frequency converter.
Speed high	Motor speed is above the value set in 4-53 <i>Warning Speed High</i> .
Speed low	Motor speed is below the value set in 4-52 <i>Warning Speed Low</i> .
Standby	In Auto On mode, the frequency converter will start the motor with a start signal from a digital input or serial communication.
Start delay	In 1-71 <i>Start Delay</i> , a delay starting time was set. A start command is activated and the motor will start after the start delay time expires.
Start fwd/rev	Start forward and start reverse were selected as functions for two different digital inputs (parameter group 5-1*). The motor will start in forward or reverse depending on which corresponding terminal is activated.
Stop	The frequency converter has received a stop command from the LCP, digital input or serial communication.
Trip	An alarm occurred and the motor is stopped. Once the cause of the alarm is cleared, the frequency converter can be reset manually by pressing [Reset] or remotely by control terminals or serial communication.
Trip lock	An alarm occurred and the motor is stopped. Once the cause of the alarm is cleared, power must be cycled to the frequency converter. The frequency converter can then be reset manually by pressing [Reset] or remotely by control terminals or serial communication.

8 Warnings and Alarms

8.1 System Monitoring

The frequency converter monitors the condition of its input power, output, and motor factors as well as other system performance indicators. A warning or alarm may not necessarily indicate a problem internal to the frequency converter itself. In many cases it indicates failure conditions from input voltage, motor load or temperature, external signals, or other areas monitored by the frequency converter's internal logic. Be sure to investigate those areas exterior to the frequency converter as indicated in the alarm or warning.

8.2 Warning and Alarm Types

Warnings

A warning is issued when an alarm condition is impending or when an abnormal operating condition is present and may result in the frequency converter issuing an alarm. A warning clears by itself when the abnormal condition is removed.

Alarms

Trip

An alarm is issued when the frequency converter is tripped, that is, the frequency converter suspends operation to prevent frequency converter or system damage. The motor will coast to a stop. The frequency converter logic will continue to operate and monitor the frequency converter status. After the fault condition is remedied, the frequency converter can be reset. It will then be ready to start operation again.

A trip can be reset in any of 4 ways:

- Press [RESET] on the LCP
- Digital reset input command
- Serial communication reset input command
- Auto reset

Trip-lock

An alarm that causes the frequency converter to trip-lock requires that input power be cycled. The motor will coast to a stop. The frequency converter logic will continue to operate and monitor the frequency converter status. Remove input power to the frequency converter and correct the cause of the fault, then restore power. This action puts the frequency converter into a trip condition as described above and may be reset in any of those 4 ways.

8.3 Warning and Alarm Displays

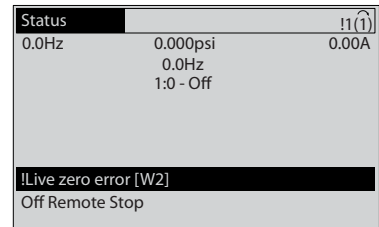

An alarm or trip-lock alarm will flash on display along with the alarm number.

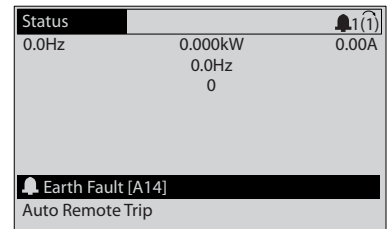

In addition to the text and alarm code on the frequency converter display, the status indicator lights operate.

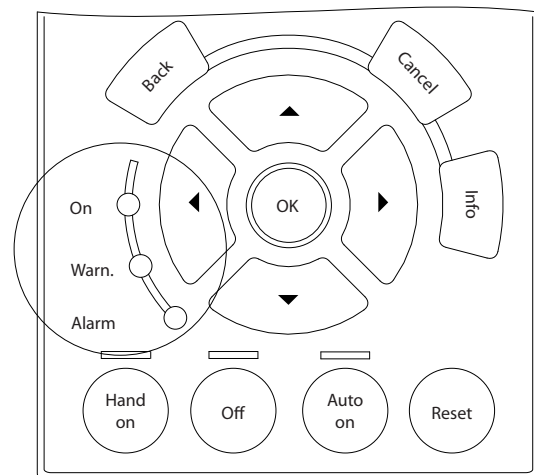

	Warn. LED	Alarm LED
Warning	ON	OFF
Alarm	OFF	ON (Flashing)
Trip-Lock	ON	ON (Flashing)

8.4 Warning and Alarm Definitions

defines whether a warning is issued prior to an alarm, and whether the alarm trips the unit or trip locks the unit.

No.	Description	Warning	Alarm/Trip	Alarm/Trip Lock	Parameter Reference
1	10 Volts low	X			
2	Live zero error	(X)	(X)		6-01 Live Zero Timeout Function
3	No motor	(X)			1-80 Function at Stop
4	Mains phase loss	(X)	(X)	(X)	14-12 Function at Mains Imbalance
5	DC link voltage high	X			
6	DC link voltage low	X			
7	DC over-voltage	X	X		
8	DC under voltage	X	X		
9	Inverter overloaded	X	X		
10	Motor ETR over temperature	(X)	(X)		1-90 Motor Thermal Protection
11	Motor thermistor over temperature	(X)	(X)		1-90 Motor Thermal Protection
12	Torque limit	X	X		
13	Over Current	X	X	X	
14	Earth Fault	X	X	X	
15	Hardware mismatch		X	X	
16	Short Circuit		X	X	
17	Control word time-out	(X)	(X)		8-04 Control Word Timeout Function
20	Temp. Input Error				
21	Param Error				
22	Hoist Mech. Brake	(X)	(X)		Parameter group 2-2*
23	Internal Fans	X			
24	External Fans	X			
25	Brake resistor short-circuited	X			
26	Brake resistor power limit	(X)	(X)		2-13 Brake Power Monitoring
27	Brake chopper short-circuited	X	X		
28	Brake check	(X)	(X)		2-15 Brake Check
29	Heatsink temp	X	X	X	
30	Motor phase U missing	(X)	(X)	(X)	4-58 Missing Motor Phase Function
31	Motor phase V missing	(X)	(X)	(X)	4-58 Missing Motor Phase Function
32	Motor phase W missing	(X)	(X)	(X)	4-58 Missing Motor Phase Function
33	Inrush Fault		X	X	
34	Fieldbus communication fault	X	X		
35	Option Fault				
36	Mains failure	X	X		
37	Phase imbalance		X		
38	Internal Fault		X	X	
39	Heatsink sensor		X	X	
40	Overload of Digital Output Terminal 27	(X)			5-00 Digital I/O Mode, 5-01 Terminal 27 Mode

No.	Description	Warning	Alarm/Trip	Alarm/Trip Lock	Parameter Reference
41	Overload of Digital Output Terminal 29	(X)			5-00 Digital I/O Mode, 5-02 Terminal 29 Mode
42	Ovrlld X30/6-7	(X)			
43	Ext. Supply (option)				
45	Earth Fault 2	X	X	X	
46	Pwr. card supply		X	X	
47	24 V supply low	X	X	X	
48	1.8 V supply low		X	X	
49	Speed limit	X			
50	AMA calibration failed		X		
51	AMA check U_{nom} and I_{nom}		X		
52	AMA low I_{nom}		X		
53	AMA motor too big		X		
54	AMA motor too small		X		
55	AMA parameter out of range		X		
56	AMA interrupted by user		X		
57	AMA time-out		X		
58	AMA internal fault	X	X		
59	Current limit	X			
61	Feedback Error	(X)	(X)		4-30 Motor Feedback Loss Function
62	Output Frequency at Maximum Limit	X			
63	Mechanical Brake Low		(X)		2-20 Release Brake Current
64	Voltage Limit	X			
65	Control Board Over-temperature	X	X	X	
66	Heat sink Temperature Low	X			
67	Option Configuration has Changed		X		
68	Safe Stop	(X)	(X) ¹⁾		5-19 Terminal 37 Safe Stop
69	Pwr. Card Temp		X	X	
70	Illegal FC configuration			X	
71	PTC 1 Safe Stop				
72	Dangerous failure				
73	Safe Stop Auto Restart	(X)	(X)		5-19 Terminal 37 Safe Stop
74	PTC Thermistor			X	
75	Illegal Profile Sel.		X		
76	Power Unit Setup	X			
77	Reduced power mode	X			14-59 Actual Number of Inverter Units
78	Tracking Error	(X)	(X)		4-34 Tracking Error Function
79	Illegal PS config		X	X	
80	Drive Initialized to Default Value		X		
81	CSIV corrupt		X		
82	CSIV parameter error		X		
83	Illegal Option Combination			X	
84	No Safety Option		X		
88	Option Detection			X	
89	Mechanical Brake Sliding	X			

No.	Description	Warning	Alarm/Trip	Alarm/Trip Lock	Parameter Reference
90	Feedback Monitor	(X)	(X)		17-61 Feedback Signal Monitoring
91	Analog input 54 wrong settings			X	S202
163	ATEX ETR cur.lim.warning	X			
164	ATEX ETR cur.lim.alarm		X		
165	ATEX ETR freq.lim.warning	X			
166	ATEX ETR freq.lim.alarm		X		
243	Brake IGBT	X	X	X	
244	Heatsink temp	X	X	X	
245	Heatsink sensor		X	X	
246	Pwr.card supply			X	
247	Pwr.card temp		X	X	
248	Illegal PS config			X	
249	Rect. low temp.	X			
250	New spare parts			X	
251	New Type Code		X	X	

Table 8.1 Alarm/Warning Code List

(X) Dependent on parameter

1) Can not be Auto reset via *14-20 Reset Mode*

8.4.1 Fault Messages

The warning/alarm information below defines the warning/ alarm condition, provides the probable cause for the condition, and details a remedy or troubleshooting procedure.

WARNING 1, 10 Volts low

The control card voltage is below 10V from terminal 50. Remove some of the load from terminal 50, as the 10V supply is overloaded. Max. 15mA or minimum 590 Ω.

This condition can be caused by a short in a connected potentiometer or improper wiring of the potentiometer.

Troubleshooting

Remove the wiring from terminal 50. If the warning clears, the problem is with the customer wiring. If the warning does not clear, replace the control card.

WARNING/ALARM 2, Live zero error

This warning or alarm will only appear if programmed by the user in *6-01 Live Zero Timeout Function*. The signal on one of the analog inputs is less than 50% of the minimum value programmed for that input. This condition can be caused by broken wiring or faulty device sending the signal.

Troubleshooting

Check connections on all the analog input terminals. Control card terminals 53 and 54 for signals, terminal 55 common. MCB 101 terminals 11 and 12 for signals, terminal 10 common. MCB 109 terminals 1, 3, 5 for signals, terminals 2, 4, 6 common).

Check that the frequency converter programming and switch settings match the analog signal type.

Perform Input Terminal Signal Test.

WARNING/ALARM 3, No motor

No motor has been connected to the output of the frequency converter.

WARNING/ALARM 4, Mains phase loss

A phase is missing on the supply side, or the mains voltage imbalance is too high. This message also appears for a fault in the input rectifier on the frequency converter. Options are programmed at *14-12 Function at Mains Imbalance*.

Troubleshooting

Check the supply voltage and supply currents to the frequency converter.

WARNING 5, DC link voltage high

The intermediate circuit voltage (DC) is higher than the high voltage warning limit. The limit is dependent on the frequency converter voltage rating. The frequency converter is still active.

WARNING 6, DC link voltage low

The intermediate circuit voltage (DC) is lower than the low voltage warning limit. The limit is dependent on the frequency converter voltage rating. The frequency converter is still active.

WARNING/ALARM 7, DC overvoltage

If the intermediate circuit voltage exceeds the limit, the frequency converter trips after a time.

Troubleshooting

- Connect a brake resistor
- Extend the ramp time
- Change the ramp type
- Activate functions in *2-10 Brake Function*
- Increase *14-26 Trip Delay at Inverter Fault*

WARNING/ALARM 8, DC under voltage

If the intermediate circuit voltage (DC) drops below the under voltage limit, the frequency converter checks if a 24V DC backup supply is connected. If no 24V DC backup supply is connected, the frequency converter trips after a fixed time delay. The time delay varies with unit size.

Troubleshooting

- Check that the supply voltage matches the frequency converter voltage.
- Perform Input voltage test
- Perform soft charge and rectifier circuit test

WARNING/ALARM 9, Inverter overload

The frequency converter is about to cut out because of an overload (too high current for too long). The counter for electronic, thermal inverter protection gives a warning at 98% and trips at 100%, while giving an alarm. The frequency converter *cannot* be reset until the counter is below 90%. The fault is that the frequency converter is overloaded by more than 100% for too long.

Troubleshooting

- Compare the output current shown on the LCP with the frequency converter rated current.
- Compare the output current shown on the LCP with measured motor current.
- Display the Thermal Drive Load on the LCP and monitor the value. When running above the frequency converter continuous current rating, the counter should increase. When running below the frequency converter continuous current rating, the counter should decrease.

See the derating section in the *Design Guide* for more details if a high switching frequency is required.

WARNING/ALARM 10, Motor overload temperature

According to the electronic thermal protection (ETR), the motor is too hot. Select whether the frequency converter gives a warning or an alarm when the counter reaches 100% in *1-90 Motor Thermal Protection*. The fault occurs when the motor is overloaded by more than 100% for too long.

Troubleshooting

- Check for motor overheating.
- Check if the motor is mechanically overloaded
- Check that the motor current set in *1-24 Motor Current* is correct.
- Ensure that Motor data in parameters 1-20 through 1-25 are set correctly.
- If an external fan is in use, check in *1-91 Motor External Fan* that it is selected.
- Running AMA in *1-29 Automatic Motor Adaptation (AMA)* may tune the frequency converter to the motor more accurately and reduce thermal loading.

WARNING/ALARM 11, Motor thermistor over temp

The thermistor might be disconnected. Select whether the frequency converter gives a warning or an alarm in *1-90 Motor Thermal Protection*.

Troubleshooting

- Check for motor overheating.
- Check if the motor is mechanically overloaded.
- When using terminal 53 or 54, check that the thermistor is connected correctly between either terminal 53 or 54 (analog voltage input) and terminal 50 (+10V supply) and that the terminal switch for 53 or 54 is set for voltage. Check *1-93 Thermistor Source* selects terminal 53 or 54.
- When using digital inputs 18 or 19, check that the thermistor is connected correctly between either terminal 18 or 19 (digital input PNP only) and terminal 50. Check *1-93 Thermistor Source* selects terminal 18 or 19.

WARNING/ALARM 12, Torque limit

The torque has exceeded the value in *4-16 Torque Limit Motor Mode* or the value in *4-17 Torque Limit Generator Mode*. *14-25 Trip Delay at Torque Limit* can change this from a warning only condition to a warning followed by an alarm.

Troubleshooting

- If the motor torque limit is exceeded during ramp up, extend the ramp up time.
- If the generator torque limit is exceeded during ramp down, extend the ramp down time.
- If torque limit occurs while running, possibly increase the torque limit. Be sure the system can operate safely at a higher torque.
- Check the application for excessive current draw on the motor.

WARNING/ALARM 13, Over current

The inverter peak current limit (approx. 200% of the rated current) is exceeded. The warning lasts about 1.5 sec., then the frequency converter trips and issues an alarm. This fault may be caused by shock loading or fast acceleration with

high inertia loads. If extended mechanical brake control is selected, trip can be reset externally.

Troubleshooting

Remove power and check if the motor shaft can be turned.

Check that the motor size matches the frequency converter.

Check parameters 1-20 through 1-25 for correct motor data.

ALARM 14, Earth (ground) fault

There is current from the output phases to earth, either in the cable between the frequency converter and the motor or in the motor itself.

Troubleshooting

Remove power to the frequency converter and repair the earth fault.

Check for earth faults in the motor by measuring the resistance to ground of the motor leads and the motor with a megohmmeter.

ALARM 15, Hardware mismatch

A fitted option is not operational with the present control board hardware or software.

Record the value of the following parameters and contact your Danfoss supplier:

15-40 FC Type

15-41 Power Section

15-42 Voltage

15-43 Software Version

15-45 Actual Typecode String

15-49 SW ID Control Card

15-50 SW ID Power Card

15-60 Option Mounted

15-61 Option SW Version

ALARM 16, Short circuit

There is a short circuit in the motor or motor wiring.

Remove power to the frequency converter and repair the short circuit.

WARNING/ALARM 17, Control word timeout

There is no communication to the frequency converter.

The warning will only be active when *8-04 Control Timeout Function* is NOT set to [0] OFF.

If *8-04 Control Timeout Function* is set to *Stop and Trip*, a warning appears and the frequency converter ramps down until it stops then displays an alarm.

Troubleshooting

Check connections on the serial communication cable.

Increase *8-03 Control Timeout Time*

Check operation of the communication equipment.

Verify proper installation based on EMC requirements.

WARNING/ALARM 20, Temp. input error

The temperature sensor is not connected.

WARNING/ALARM 21, Parameter error

The parameter is out of range. The parameter number is reported in the LCP. The affected parameter must be set to a valid value.

WARNING/ALARM 22, Hoist mechanical brake

Report value will show what kind it is. 0 = The torque ref. was not reached before timeout. 1 = There was no brake feedback before timeout.

WARNING 23, Internal fan fault

The fan warning function checks if the fan is running. The fan warning can be disabled in *14-53 Fan Monitor*.

Troubleshooting

Check for proper fan operation.

Cycle power to the frequency converter and check that the fan operates briefly at start up.

Check the sensors on the heatsink and control card.

WARNING 24, External fan fault

The fan warning function checks if the fan is running. The fan warning can be disabled in *14-53 Fan Monitor*.

Troubleshooting

Check for proper fan operation.

Cycle power to the frequency converter and check that the fan operates briefly at start up.

Check the sensors on the heatsink and control card.

WARNING 25, Brake resistor short circuit

The brake resistor is monitored during operation. If a short circuit occurs, the brake function is disabled and the warning appears. The frequency converter is still operational but without the brake function. Remove power to the frequency converter and replace the brake resistor (see *2-15 Brake Check*).

WARNING/ALARM 26, Brake resistor power limit

The power transmitted to the brake resistor is calculated as a mean value over the last 120 seconds of run time. The calculation is based on the intermediate circuit voltage and the brake resistance value set in *2-16 AC brake Max. Current*. The warning is active when the dissipated braking is higher than 90% of the brake resistance power. If *Trip [2]* is selected in *2-13 Brake Power Monitoring*, the frequency converter will trip when the dissipated braking power reaches 100%.

WARNING/ALARM 27, Brake chopper fault

The brake transistor is monitored during operation and if a short circuit occurs, the brake function is disabled and a warning is issued. The frequency converter is still operational but, since the brake transistor has short-circuited, substantial power is transmitted to the brake resistor, even if it is inactive.

Remove power to the frequency converter and remove the brake resistor.

WARNING/ALARM 28, Brake check failed

The brake resistor is not connected or not working. Check *2-15 Brake Check*.

ALARM 29, Heatsink temp

The maximum temperature of the heatsink has been exceeded. The temperature fault will not reset until the temperature falls below the reset heatsink temperature. The trip and reset points are based on the frequency converter power size.

Troubleshooting

Check for the following conditions.

- Ambient temperature too high.
- Motor cable too long.
- Incorrect airflow clearance above and below the frequency converter.
- Blocked airflow around the frequency converter.
- Damaged heatsink fan.
- Dirty heatsink.

ALARM 30, Motor phase U missing

Motor phase U between the frequency converter and the motor is missing.

Remove power from the frequency converter and check motor phase U.

ALARM 31, Motor phase V missing

Motor phase V between the frequency converter and the motor is missing.

Remove power from the frequency converter and check motor phase V.

ALARM 32, Motor phase W missing

Motor phase W between the frequency converter and the motor is missing.

Remove power from the frequency converter and check motor phase W.

ALARM 33, Inrush fault

Too many power-ups have occurred within a short time period. Let the unit cool to operating temperature.

WARNING/ALARM 34, communication fault

Communication between the and the communication option card is not operating.

WARNING/ALARM 35, Option fault

An option alarm is received. The alarm is option specific. The most likely cause is a power-up or a communication fault.

WARNING/ALARM 36, Mains failure

This warning/alarm is only active if the supply voltage to the frequency converter is lost and *14-10 Mains Failure* is NOT set to [0] *No Function*. Check the fuses to the frequency converter and mains power supply to the unit.

ALARM 37, Phase imbalance

There is a current imbalance between the power units

ALARM 38, Internal fault

When an internal fault occurs, a code number defined in the table below is displayed.

Troubleshooting

- Cycle power to the frequency converter.
- Check that the option is properly installed.
- Check for loose or missing wiring.

It may be necessary to contact your Danfoss supplier or service department. Note the code number for further troubleshooting directions.

No.	Text
0	Serial port cannot be initialised. Contact your Danfoss supplier or Danfoss Service Department.
256-258	Power EEPROM data is defect or too old
512-519	Internal fault. Contact your Danfoss supplier or Danfoss Service Department.
783	Parameter value outside of min/max limits
1024-1284	Internal fault. Contact your Danfoss supplier or the Danfoss Service Department.
1299	Option SW in slot A is too old
1300	Option SW in slot B is too old
1302	Option SW in slot C1 is too old
1315	Option SW in slot A is not supported (not allowed)
1316	Option SW in slot B is not supported (not allowed)
1318	Option SW in slot C1 is not supported (not allowed)
1379-2819	Internal fault. Contact your Danfoss supplier or Danfoss Service Department.
2820	LCP stack overflow
2821	Serial port overflow
2822	USB port overflow
3072-5122	Parameter value is outside its limits
5123	Option in slot A: Hardware incompatible with control board hardware
5124	Option in slot B: Hardware incompatible with control board hardware
5125	Option in slot C0: Hardware incompatible with control board hardware
5126	Option in slot C1: Hardware incompatible with control board hardware
5376-6231	Internal fault. Contact your Danfoss supplier or Danfoss Service Department.

ALARM 39, Heatsink sensor

No feedback from the heatsink temperature sensor.

The signal from the IGBT thermal sensor is not available on the power card. The problem could be on the power card, on the gate drive card, or the ribbon cable between the power card and gate drive card.

WARNING 40, Overload of digital output terminal 27

Check the load connected to terminal 27 or remove short-circuit connection. Check *5-00 Digital I/O Mode* and *5-01 Terminal 27 Mode*.

WARNING 41, Overload of digital output terminal 29

Check the load connected to terminal 29 or remove short-circuit connection. Check *5-00 Digital I/O Mode* and *5-02 Terminal 29 Mode*.

WARNING 42, Overload of digital output on X30/6 or overload of digital output on X30/7

For X30/6, check the load connected to X30/6 or remove short-circuit connection. Check *5-32 Term X30/6 Digi Out (MCB 101)*.

For X30/7, check the load connected to X30/7 or remove short-circuit connection. Check *5-33 Term X30/7 Digi Out (MCB 101)*.

ALARM 43, Ext. supply

MCB 113 Ext. Relay Option is mounted without ext. 24V DC. Either connect an ext. 24V DC supply or specify that no external supply is used via *14-80 Option Supplied by External 24VDC [0]*. A change in *14-80 Option Supplied by External 24VDC* requires a power cycle.

ALARM 45, Earth fault 2

Earth (ground) fault on start up.

Troubleshooting

Check for proper earthing (grounding) and loose connections.

Check for proper wire size.

Check motor cables for short-circuits or leakage currents.

ALARM 46, Power card supply

The supply on the power card is out of range.

There are three power supplies generated by the switch mode power supply (SMPS) on the power card: 24V, 5V, +/- 18V. When powered with 24V DC with the MCB 107 option, only the 24V and 5V supplies are monitored. When powered with three phase mains voltage, all three supplied are monitored.

Troubleshooting

Check for a defective power card.

Check for a defective control card.

Check for a defective option card.

If a 24V DC power supply is used, verify proper supply power.

WARNING 47, 24V supply low

The 24 V DC is measured on the control card. The external 24V DC backup power supply may be overloaded, otherwise contact your Danfoss supplier.

WARNING 48, 1.8V supply low

The 1.8V DC supply used on the control card is outside of allowable limits. The power supply is measured on the control card. Check for a defective control card. If an option card is present, check for an overvoltage condition.

WARNING 49, Speed limit

When the speed is not within the specified range in *4-11 Motor Speed Low Limit [RPM]* and *4-13 Motor Speed High Limit [RPM]*, the frequency converter will show a warning. When the speed is below the specified limit in *1-86 Trip Speed Low [RPM]* (except when starting or stopping) the frequency converter will trip.

ALARM 50, AMA calibration failed

Contact your Danfoss supplier or Danfoss Service Department.

ALARM 51, AMA check U_{nom} and I_{nom}

The settings for motor voltage, motor current, and motor power are wrong. Check the settings in parameters 1-20 to 1-25.

ALARM 52, AMA low I_{nom}

The motor current is too low. Check the setting in *4-18 Current Limit*.

ALARM 53, AMA motor too big

The motor is too big for the AMA to operate.

ALARM 54, AMA motor too small

The motor is too small for the AMA to operate.

ALARM 55, AMA Parameter out of range

The parameter values of the motor are outside of the acceptable range. AMA will not run.

ALARM 56, AMA interrupted by user

The AMA has been interrupted by the user.

ALARM 57, AMA timeout

Try to restart AMA again. Repeated restarts may over heat the motor.

ALARM 58, AMA internal fault

Contact your Danfoss supplier.

WARNING 59, Current limit

The current is higher than the value in *4-18 Current Limit*. Ensure that Motor data in parameters 1-20 through 1-25 are set correctly. Possibly increase the current limit. Be sure the system can operate safely at a higher limit.

ALARM 60, External interlock

A digital input signal is indicating a fault condition external to the frequency converter. An external interlock has commanded the frequency converter to trip. Clear the external fault condition. To resume normal operation, apply 24V DC to the terminal programmed for external interlock. Reset the frequency converter.

WARNING/ALARM 61, Feedback error

An error between calculated speed and speed measurement from feedback device. The function Warning/Alarm/Disabling setting is in *4-30 Motor Feedback Loss Function*. Accepted error setting in *4-31 Motor Feedback Speed Error* and the allowed time the error occur setting in *4-32 Motor Feedback Loss Timeout*. During a commissioning procedure the function may be effective.

WARNING 62, Output frequency at maximum limit

The output frequency has reached the value set in *4-19 Max Output Frequency*. Check the application to determine the cause. Possibly increase the output frequency limit. Be sure the system can operate safely at a higher output frequency. The warning will clear when the output drops below the maximum limit.

ALARM 63, Mechanical brake low

The actual motor current has not exceeded the “release brake” current within the “Start delay” time window.

WARNING/ALARM 65, Control card over temperature

The cutout temperature of the control card is 80° C.

Troubleshooting

Check that the ambient operating temperature is within limits.

Check for clogged filters.

Check fan operation.

Check the control card.

WARNING 66, Heatsink temperature low

The frequency converter is too cold to operate. This warning is based on the temperature sensor in the IGBT module. Increase the ambient temperature of the unit. Also, a trickle amount of current can be supplied to the frequency converter whenever the motor is stopped by setting *2-00 DC Hold/Preheat Current* at 5% and *1-80 Function at Stop*.

ALARM 67, Option module configuration has changed

One or more options have either been added or removed since the last power down. Check that the configuration change is intentional and reset the frequency converter.

ALARM 68, Safe stop activated

Loss of the 24V DC signal on terminal 37 has caused the frequency converter to trip. To resume normal operation, apply 24V DC to terminal 37 and reset the frequency converter.

ALARM 69, Power card temperature Power card temperature

The temperature sensor on the power card is either too hot or too cold.

Troubleshooting

Check that the ambient operating temperature is within limits.

Check for clogged filters.

Check fan operation.

Check the power card.

ALARM 70, Illegal FC configuration

The control card and power card are incompatible. Contact your supplier with the typecode of the unit from the nameplate and the part numbers of the cards to check compatibility.

ALARM 71, PTC 1 safe stop

Safe Stop has been activated from the MCB 112 PTC Thermistor Card (motor too warm). Normal operation can be resumed when the MCB 112 applies 24 V DC to T-37 again

(when the motor temperature reaches an acceptable level) and when the Digital Input from the MCB 112 is deactivated. When that happens, a reset signal must be sent (via Bus, Digital I/O, or by pressing [RESET]).

ALARM 72, Dangerous failure

Safe Stop with Trip Lock. The Dangerous Failure Alarm is issued if the combination of safe stop commands is unexpected. This is the case if the MCB 112 VLT PTC Thermistor Card enables X44/10 but safe stop is somehow not enabled. Furthermore, if the MCB 112 is the only device using safe stop (specified through selection [4] or [5] in *5-19 Terminal 37 Safe Stop*), an unexpected combination is activation of safe stop without the X44/10 being activated. The following table summarizes the unexpected combinations that lead to Alarm 72. Note that if X44/10 is activated in selection 2 or 3, this signal is ignored! However, the MCB 112 will still be able to activate Safe Stop.

WARNING 73, Safe stop auto restart

Safe stopped. Note that with automatic restart enabled, the motor may start when the fault is cleared.

ALARM 74, PTC Thermistor

Alarm related to the ATEX option. The PTC is not working.

ALARM 75, Illegal profile sel.

Parameter value must not be written while motor is running. Stop motor before writing MCO profile to *8-10 Control Word Profile* for instance.

WARNING 76, Power unit setup

The required number of power units does not match the detected number of active power units.

Troubleshooting:

When replacing an F-frame module, this will occur if the power specific data in the module power card does not match the rest of the frequency converter. Please confirm the spare part and its power card are the correct part number.

77 WARNING, Reduced power mode

This warning indicates that the frequency converter is operating in reduced power mode (i.e. less than the allowed number of inverter sections). This warning will be generated on power cycle when the frequency converter is set to run with fewer inverters and will remain on.

ALARM 78, Tracking error

The difference between set point value and actual value has exceeded the value in *4-35 Tracking Error*. Disable the function by *4-34 Tracking Error Function* or select an alarm/warning also in *4-34 Tracking Error Function*. Investigate the mechanics around the load and motor, Check feedback connections from motor – encoder – to frequency converter. Select motor feedback function in *4-30 Motor Feedback Loss Function*. Adjust tracking error band in *4-35 Tracking Error* and *4-37 Tracking Error Ramping*.

ALARM 79, Illegal power section configuration

The scaling card is the incorrect part number or not installed. Also MK102 connector on the power card could not be installed.

ALARM 80, Drive initialised to default value

Parameter settings are initialised to default settings after a manual reset. Reset the unit to clear the alarm.

ALARM 81, CSIV corrupt

CSIV file has syntax errors.

ALARM 82, CSIV parameter error

CSIV failed to init a parameter.

ALARM 83, Illegal option combination

The mounted options are not supported to work together.

ALARM 84, No safety option

The safety option was removed without applying a general reset. Reconnect the safety option.

ALARM 88, Option detection

A change in the option layout has been detected. This alarm occurs when *14-89 Option Detection* is set to [0] *Frozen configuration* and the option layout for some reason has changed. An option layout change has to be enabled in *14-89 Option Detection* before the change is accepted. If the change of configuration is not accepted, it is only possible to reset Alarm 88 (Trip-lock) when the option configuration has been re-established/corrected.

WARNING 89, Mechanical brake sliding

The hoist brake monitor has detected a motor speed > 10rpm.

ALARM 90, Feedback monitor

Check the connection to encoder/ resolver option and eventually replace the MCB 102 or MCB 103.

ALARM 91, Analogue input 54 wrong settings

Switch S202 has to be set in position OFF (voltage input) when a KTY sensor is connected to analogue input terminal 54.

ALARM 92, No flow

A no-flow condition has been detected in the system. *22-23 No-Flow Function* is set for alarm. Troubleshoot the system and reset the frequency converter after the fault has been cleared.

ALARM 93, Dry pump

A no-flow condition in the system with the frequency converter operating at high speed may indicate a dry pump. *22-26 Dry Pump Function* is set for alarm. Troubleshoot the system and reset the frequency converter after the fault has been cleared.

ALARM 94, End of curve

Feedback is lower than the set point. This may indicate leakage in the system. *22-50 End of Curve Function* is set for alarm. Troubleshoot the system and reset the frequency converter after the fault has been cleared.

ALARM 95, Broken belt

Torque is below the torque level set for no load, indicating a broken belt. *22-60 Broken Belt Function* is set for alarm.

Troubleshoot the system and reset the frequency converter after the fault has been cleared.

ALARM 96, Start delayed

Motor start has been delayed due to short-cycle protection. *22-76 Interval between Starts* is enabled. Troubleshoot the system and reset the frequency converter after the fault has been cleared.

WARNING 97, Stop delayed

Stopping the motor has been delayed due to short cycle protection. *22-76 Interval between Starts* is enabled.

Troubleshoot the system and reset the frequency converter after the fault has been cleared.

WARNING 98, Clock fault

Time is not set or the RTC clock has failed. Reset the clock in *0-70 Date and Time*.

WARNING 163, ATEX ETR cur.lim.warning

The warning limit of ATEX ETR rated current curve has been reached. The warning is activated at 83% and de-activated at 65% of the permitted thermal overload.

ALARM 164, ATEX ETR cur.lim.alarm

The ATEX ETR permitted thermal overload has been exceeded.

WARNING 165, ATEX ETR freq.lim.warning

The frequency converter is running more than 50 seconds below the permitted minimum frequency (*1-98 ATEX ETR interpol. points freq. [0]*).

ALARM 166, ATEX ETR freq.lim.alarm

The frequency converter has operated more than 60 second (in a period of 600 seconds) below the permitted minimum frequency (*1-98 ATEX ETR interpol. points freq. [0]*).

ALARM 243, Brake IGBT

This alarm is only for F Frame drives. It is equivalent to Alarm 27. The report value in the alarm log indicates which power module generated the alarm:

ALARM 244, Heatsink temperature

This alarm is only for F Frame frequency converters. It is equivalent to Alarm 29. The report value in the alarm log indicates which power module generated the alarm:

ALARM 245, Heatsink sensor

This alarm is only for F Frame frequency converters. It is equivalent to Alarm 39. The report value in the alarm log indicates which power module generated the alarm

1 = left most inverter module.

2 = middle inverter module in F2 or F4 frequency converter.

2 = right inverter module in F1 or F3 frequency converter.

3 = right inverter module in F2 or F4 frequency converter.

5 = rectifier module.

ALARM 246, Power card supply

This alarm is only for F Frame frequency converter. It is equivalent to Alarm 46. The report value in the alarm log indicates which power module generated the alarm

1 = left most inverter module.

2 = middle inverter module in F2 or F4 frequency converter.

2 = right inverter module in F1 or F3 frequency converter.

3 = right inverter module in F2 or F4 frequency converter.

5 = rectifier module.

ALARM 69, Power card temperaturePower card temperature

This alarm is only for F Frame frequency converter. It is equivalent to Alarm 69. The report value in the alarm log indicates which power module generated the alarm

1 = left most inverter module.

2 = middle inverter module in F2 or F4 frequency converter.

2 = right inverter module in F1 or F3 frequency converter.

3 = right inverter module in F2 or F4 frequency converter.

5 = rectifier module.

ALARM 248, Illegal power section configuration

This alarm is only for F Frame frequency converters. It is equivalent to Alarm 79. The report value in the alarm log indicates which power module generated the alarm:

1 = left most inverter module.

2 = middle inverter module in F2 or F4 frequency converter.

2 = right inverter module in F1 or F3 frequency converter.

3 = right inverter module in F2 or F4 frequency converter.

5 = rectifier module.

WARNING 249, Rect. low temperature

IGBT sensor fault (highpower units only).

WARNING 250, New spare part

A component in the frequency converter has been replaced. Reset the frequency converter for normal operation.

WARNING 251, New typecode

A component in the frequency converter has been replaced and the typecode changed. Reset the frequency converter for normal operation.

9 Basic Troubleshooting

9.1 Start Up and Operation

See *Alarm Log* in *Table 4.1*.

Symptom	Possible Cause	Test	Solution
Display dark / No function	Missing input power	See <i>Table 3.1</i> .	Check the input power source.
	Missing or open fuses or circuit breaker tripped	See open fuses and tripped circuit breaker in this table for possible causes.	Follow the recommendations provided
	No power to the LCP	Check the LCP cable for proper connection or damage.	Replace the faulty LCP or connection cable.
	Shortcut on control voltage (terminal 12 or 50) or at control terminals	Check the 24V control voltage supply for terminal 12/13 to 20-39 or 10V supply for terminal 50 to 55.	Wire the terminals properly.
	Wrong LCP (LCP from VLT® 2800 or 5000/6000/8000/ FCD or FCM)		Use only LCP 101 (P/N 130B1124) or LCP 102 (P/N. 130B1107).
	Wrong contrast setting		Press [Status] + Up/Down arrows to adjust the contrast.
	Display (LCP) is defective	Test using a different LCP.	Replace the faulty LCP or connection cable.
	Internal voltage supply fault or SMPS is defective		Contact supplier.
Intermittent display	Overloaded power supply (SMPS) due to improper control wiring or a fault within the frequency converter	To rule out a problem in the control wiring, disconnect all control wiring by removing the terminal blocks.	If the display stays lit, then the problem is in the control wiring. Check the wiring for shorts or incorrect connections. If the display continues to cut out, follow the procedure for display dark.
Motor not running	Service switch open or missing motor connection	Check if the motor is connected and the connection is not interrupted (by a service switch or other device).	Connect the motor and check the service switch.
	No mains power with 24V DC option card	If the display is functioning but no output, check that mains power is applied to the frequency converter.	Apply mains power to run the unit.
	LCP Stop	Check if [Off] has been pressed.	Press [Auto On] or [Hand On] (depending on your operation mode) to run the motor.
	Missing start signal (Standby)	Check <i>5-10 Start</i> for correct setting for terminal 18 (use default setting).	Apply a valid start signal to start the motor.
	Motor coast signal active (Coasting)	Check <i>5-12 Coast inv.</i> for correct setting for terminal 27 (use default setting).	Apply 24V on terminal 27 or programm this terminal to <i>No operation</i> .
	Wrong reference signal source	Check reference signal: Local, remote or bus reference? Preset reference active? Terminal connection correct? Scaling of terminals correct? Reference signal available?	Program correct settings Check <i>3-13 Reference site</i> . Set preset reference active in parameter group <i>3-1* References</i> . Check for correct wiring. Check scaling of terminals. Check reference signal.

Symptom	Possible Cause	Test	Solution
Motor running in wrong direction	Motor rotation limit	Check that 4-10 <i>Motor speed direction</i> is programmed correctly.	Program correct settings.
	Active reversing signal	Check if a reversing command is programmed for the terminal in parameter group 5-1* <i>Digital inputs</i> .	Deactivate reversing signal.
	Wrong motor phase connection		See 3.5 <i>Check Motor Rotation</i> in this manual.
Motor is not reaching maximum speed	Frequency limits set wrong	Check output limits in 4-13 <i>Motor speed high limit [RPM]</i> , 4-14 <i>Motor speed high limit [Hz]</i> , and 4-19 <i>Max output frequency</i> .	Program correct limits.
	Reference input signal not scaled correctly	Check reference input signal scaling in 6-* <i>Analog I/O mode</i> and parameter group 3-1* <i>References</i> .	Program correct settings.
Motor speed unstable	Possible incorrect parameter settings	Check the settings of all motor parameters, including all motor compensation settings. For closed loop operation, check PID settings.	Check settings in parameter group 1-6* <i>Analog I/O mode</i> . For closed loop operation check settings in parameter group 20-0* <i>Feedback</i> .
Motor runs rough	Possible over-magnetization	Check for incorrect motor settings in all motor parameters.	Check motor settings in parameter groups 1-2* <i>Motor data</i> , 1-3* <i>Adv motor data</i> , and 1-5* <i>Load indep. setting</i> .
Motor will not brake	Possible incorrect settings in the brake parameters. Possible too short ramp down times.	Check brake parameters. Check ramp time settings.	Check parameter group 2-0* <i>DC brake</i> and 3-0* <i>Reference limits</i> .
Open power fuses or circuit breaker trip	Phase to phase short	Motor or panel has a short phase to phase. Check motor and panel phase to for shorts.	Eliminate any shorts detected.
	Motor overload	Motor is overloaded for the application.	Perform startup test and verify motor current is within specifications. If motor current is exceeding nameplate full load current, motor may run only with reduced load. Review the specifications for the application.
	Loose connections	Perform pre-startup check for loose connections.	Tighten loose connections.
Mains current imbalance greater than 3%	Problem with mains power (See <i>Alarm 4 Mains phase loss</i> description)	Rotate input power leads into the drive one position: A to B, B to C, C to A.	If imbalanced leg follows the wire, it is a power problem. Check mains power supply.
	Problem with the frequency converter unit	Rotate input power leads into the frequency converter one position: A to B, B to C, C to A.	If imbalance leg stays on same input terminal, it is a problem with the unit. Contact supplier.
Motor current imbalance greater than 3%	Problem with motor or motor wiring	Rotate output motor leads one position: U to V, V to W, W to U.	If imbalanced leg follows the wire, the problem is in the motor or motor wiring. Check motor and motor wiring.
	Problem with drive unit	Rotate output motor leads one position: U to V, V to W, W to U.	If imbalance leg stays on same output terminal, it is a problem with the unit. Contact supplier.

10 Specifications

10.1 Power-dependent Specifications

Mains Supply 3 x 200 - 240V AC										
FC 301/FC 302		PK25	PK37	PK55	PK75	P1K1	P1K5	P2K2	P3K0	P3K7
	Typical Shaft Output [kW]	0.25	0.37	0.55	0.75	1.1	1.5	2.2	3	3.7
	Enclosure IP20/IP21	A2	A2	A2	A2	A2	A2	A2	A3	A3
	Enclosure IP 20 (FC 301 only)	A1	A1	A1	A1	A1	A1	-	-	-
	Enclosure IP55, 66	A4/A5	A4/A5	A4/A5	A4/A5	A4/A5	A4/A5	A4/A5	A5	A5
Output current										
	Continuous (3 x 200-240V) [A]	1.8	2.4	3.5	4.6	6.6	7.5	10.6	12.5	16.7
	Intermittent (3 x 200-240V) [A]	2.9	3.8	5.6	7.4	10.6	12.0	17.0	20.0	26.7
	Continuous kVA (208V AC) [kVA]	0.65	0.86	1.26	1.66	2.38	2.70	3.82	4.50	6.00
Max. input current										
	Continuous (3 x 200-240V) [A]	1.6	2.2	3.2	4.1	5.9	6.8	9.5	11.3	15.0
	Intermittent (3 x 200-240V) [A]	2.6	3.5	5.1	6.6	9.4	10.9	15.2	18.1	24.0
Additional specifications										
	Max. cable size (mains, motor, brake) [mm ² (AWG ²⁾]	0.2 - 4 (24 - 10)								
	Estimated power loss at rated max. load [W] ⁴⁾	21	29	42	54	63	82	116	155	185
	Weight, enclosure IP20 [kg]	4.7	4.7	4.8	4.8	4.9	4.9	4.9	6.6	6.6
	A1 (IP20)	2.7	2.7	2.7	2.7	2.7	2.7	-	-	-
	A5 (IP55, 66)	13.5	13.5	13.5	13.5	13.5	13.5	13.5	13.5	13.5
	Efficiency ⁴⁾	0.94	0.94	0.95	0.95	0.96	0.96	0.96	0.96	0.96

0.25 - 3.7kW only available as 160% high overload.

Mains Supply 3 x 200 - 240V AC							
FC 301/FC 302		P5K5		P7K5		P11K	
High/ Normal Load ¹⁾		HO	NO	HO	NO	HO	NO
	Typical Shaft Output [kW]	5.5	7.5	7.5	11	11	15
	Enclosure IP20	B3		B3		B4	
	Enclosure IP21	B1		B1		B2	
	Enclosure IP55, 66	B1		B1		B2	
Output current							
	Continuous (3 x 200-240V) [A]	24.2	30.8	30.8	46.2	46.2	59.4
	Intermittent (60 sec overload) (3 x 200-240V) [A]	38.7	33.9	49.3	50.8	73.9	65.3
	Continuous kVA (208V AC) [kVA]	8.7	11.1	11.1	16.6	16.6	21.4
Max. input current							
	Continuous (3 x 200-240V) [A]	22	28	28	42	42	54
	Intermittent (60 sec overload) (3 x 200-240V) [A]	35.2	30.8	44.8	46.2	67.2	59.4
Additional specifications							
	Max. cable size [mm ² (AWG)] ²⁾	16 (6)		16 (6)		35 (2)	
	Max cable size with mains disconnect	16 (6)					
	Estimated power loss at rated max. load [W] ⁴⁾	239	310	371	514	463	602
	Weight, enclosure IP21, IP55, 66 [kg]	23		23		27	
	Efficiency ⁴⁾	0.964		0.959		0.964	

Mains Supply 3 x 200 - 240V AC											
FC 301/FC 302		P15K		P18K		P22K		P30K		P37K	
High/ Normal Load ¹⁾		HO	NO	HO	NO	HO	NO	HO	NO	HO	NO
Typical Shaft Output [kW]		15	18.5	18.5	22	22	30	30	37	37	45
Enclosure IP20		B4		C3		C3		C4		C4	
Enclosure IP21		C1		C1		C1		C1		C1	
Enclosure IP55, 66		C1		C1		C1		C2		C2	
Output current											
Continuous (3 x 200-240V) [A]		59.4	74.8	74.8	88	88	115	115	143	143	170
Intermittent (60 sec overload) (3 x 200-240V) [A]		89.1	82.3	112	96.8	132	127	173	157	215	187
Continuous kVA (208V AC) [kVA]		21.4	26.9	26.9	31.7	31.7	41.4	41.4	51.5	51.5	61.2
Max. input current											
Continuous (3 x 200-240V) [A]		54	68	68	80	80	104	104	130	130	154
Intermittent (60 sec overload) (3 x 200-240V) [A]		81	74.8	102	88	120	114	156	143	195	169
Additional specifications											
Max. cable size, IP20 [mm ² (AWG)] ²⁾		35 (2)		90 (3/0)		90 (3/0)		120 (4/0)		120 (4/0)	
Max. cable size, IP21/55/66 [mm ² (AWG)] ²⁾		90 (3/0)		90 (3/0)		90 (3/0)		120 (4/0)		120 (4/0)	
Max cable size with mains disconnect [mm ² (AWG)] ²⁾		35 (2)						70 (3/0)		150 (MCM 300)	
Estimated power loss at rated max. load [W] ⁴⁾		624	737	740	845	874	1140	1143	1353	1400	1636
Weight, enclosure IP21, IP 55, 66 [kg]		45		45		45		65		65	
Efficiency ⁴⁾		0.96		0.97		0.97		0.97		0.97	

Mains Supply 3 x 380 - 500V AC (FC 302), 3 x 380 - 480V AC (FC 301)											
		PK 37	PK 55	PK75	P1K1	P1K5	P2K2	P3K0	P4K0	P5K5	P7K5
FC 301/FC 302		0.37	0.55	0.75	1.1	1.5	2.2	3	4	5.5	7.5
Typical Shaft Output [kW]											
Enclosure IP20/IP21		A2	A2	A2	A2	A2	A2	A2	A2	A3	A3
Enclosure IP20 (FC 301 only)		A1	A1	A1	A1	A1					
Enclosure IP55, 66		A4/A5	A4/A5	A4/A5	A4/A5	A4/A5	A4/A5	A4/A5	A4/A5	A5	A5
Output current											
High overload 160% for 1 min.											
Shaft output [kW]		0.37	0.55	0.75	1.1	1.5	2.2	3	4	5.5	7.5
Continuous (3 x 380-440V) [A]		1.3	1.8	2.4	3	4.1	5.6	7.2	10	13	16
Intermittent (3 x 380-440V) [A]		2.1	2.9	3.8	4.8	6.6	9.0	11.5	16	20.8	25.6
Continuous (3 x 441-500V) [A]		1.2	1.6	2.1	2.7	3.4	4.8	6.3	8.2	11	14.5
Intermittent (3 x 441-500V) [A]		1.9	2.6	3.4	4.3	5.4	7.7	10.1	13.1	17.6	23.2
Continuous kVA (400V AC) [kVA]		0.9	1.3	1.7	2.1	2.8	3.9	5.0	6.9	9.0	11.0
Continuous kVA (460V AC) [kVA]		0.9	1.3	1.7	2.4	2.7	3.8	5.0	6.5	8.8	11.6
Max. input current											
Continuous (3 x 380-440V) [A]		1.2	1.6	2.2	2.7	3.7	5.0	6.5	9.0	11.7	14.4
Intermittent (3 x 380-440V) [A]		1.9	2.6	3.5	4.3	5.9	8.0	10.4	14.4	18.7	23.0
Continuous (3 x 441-500V) [A]		1.0	1.4	1.9	2.7	3.1	4.3	5.7	7.4	9.9	13.0
Intermittent (3 x 441-500V) [A]		1.6	2.2	3.0	4.3	5.0	6.9	9.1	11.8	15.8	20.8
Additional specifications											
Max. cable size (mains, motor, brake) [AWG] ²⁾ [mm ²]		24 - 10 AWG 0.2 - 4mm ²						24 - 10 AWG 0.2 - 4mm ²			
Estimated power loss at rated max. load [W] ⁴⁾		35	42	46	58	62	88	116	124	187	255
Weight, enclosure IP20		4.7	4.7	4.8	4.8	4.9	4.9	4.9	4.9	6.6	6.6
Enclosure IP55, 66		13.5	13.5	13.5	13.5	13.5	13.5	13.5	13.5	14.2	14.2
Efficiency ⁴⁾		0.93	0.95	0.96	0.96	0.97	0.97	0.97	0.97	0.97	0.97

0.37 - 7.5 kW only available as 160% high overload.

Mains Supply 3 x 380 - 500V AC (FC 302), 3 x 380 - 480V AC (FC 301)									
FC 301/FC 302		P11K		P15K		P18K		P22K	
High/ Normal Load ¹⁾		HO	NO	HO	NO	HO	NO	HO	NO
	Typical Shaft output [kW]	11	15	15	18.5	18.5	22.0	22.0	30.0
	Enclosure IP20	B3		B3		B4		B4	
	Enclosure IP21	B1		B1		B2		B2	
	Enclosure IP55, 66	B1		B1		B2		B2	
Output current									
	Continuous (3 x 380-440V) [A]	24	32	32	37.5	37.5	44	44	61
	Intermittent (60 sec overload) (3 x 380-440V) [A]	38.4	35.2	51.2	41.3	60	48.4	70.4	67.1
	Continuous (3 x 441-500V) [A]	21	27	27	34	34	40	40	52
	Intermittent (60 sec overload) (3 x 441-500V) [A]	33.6	29.7	43.2	37.4	54.4	44	64	57.2
	Continuous kVA (400V AC) [kVA]	16.6	22.2	22.2	26	26	30.5	30.5	42.3
	Continuous kVA (460V AC) [kVA]		21.5		27.1		31.9		41.4
	Max. input current								
	Continuous (3 x 380-440V) [A]	22	29	29	34	34	40	40	55
	Intermittent (60 sec overload) (3 x 380-440V) [A]	35.2	31.9	46.4	37.4	54.4	44	64	60.5
	Continuous (3 x 441-500V) [A]	19	25	25	31	31	36	36	47
	Intermittent (60 sec overload) (3 x 441-500V) [A]	30.4	27.5	40	34.1	49.6	39.6	57.6	51.7
Additional specifications									
	Max. cable size [mm ² /AWG] ²⁾	16/6		16/6		35/2		35/2	
	Max cable size with mains disconnect	16/6							
	Estimated power loss at rated max. load [W] ⁴⁾	291	392	379	465	444	525	547	739
	Weight, enclosure IP20 [kg]	12		12		23.5		23.5	
	Weight, enclosure IP21, IP55, 66 [kg]	23		23		27		27	
	Efficiency ⁴⁾	0.98		0.98		0.98		0.98	

Mains Supply 3 x 380 - 500 V AC (FC 302), 3 x 380 - 480V AC (FC 301)											
FC 301/FC 302		P30K		P37K		P45K		P55K		P75K	
High/ Normal Load ¹⁾		HO	NO	HO	NO	HO	NO	HO	NO	HO	NO
	Typical Shaft output [kW]	30	37	37	45	45	55	55	75	75	90
	Enclosure IP20	B4		C3		C3		C4		C4	
	Enclosure IP21	C1		C1		C1		C2		C2	
	Enclosure IP55, 66	C1		C1		C1		C2		C2	
Output current											
	Continuous (3 x 380-440V) [A]	61	73	73	90	90	106	106	147	147	177
	Intermittent (60 sec. overload) (3 x 380-440V) [A]	91.5	80.3	110	99	135	117	159	162	221	195
	Continuous (3 x 441-500V) [A]	52	65	65	80	80	105	105	130	130	160
	Intermittent (60 sec. overload) (3 x 441-500V) [A]	78	71.5	97.5	88	120	116	158	143	195	176
	Continuous kVA (400V AC) [kVA]	42.3	50.6	50.6	62.4	62.4	73.4	73.4	102	102	123
	Continuous kVA (460V AC) [kVA]		51.8		63.7		83.7		104		128
Max. input current											
	Continuous (3 x 380-440V) [A]	55	66	66	82	82	96	96	133	133	161
	Intermittent (60 sec. overload) (3 x 380-440V) [A]	82.5	72.6	99	90.2	123	106	144	146	200	177
	Continuous (3 x 441-500V) [A]	47	59	59	73	73	95	95	118	118	145
	Intermittent (60 sec. overload) (3 x 441-500V) [A]	70.5	64.9	88.5	80.3	110	105	143	130	177	160
Additional specifications											
	Max. cable size IP20, mains and motor [mm ² (AWG ²⁾]	35 (2)		50 (1)		50 (1)		95 (4/0)		150 (300mcm)	
	Max. cable size IP20, load share and brake [mm ² (AWG ²⁾]	35 (2)		50 (1)		50 (1)		95 (4/0)		95 (4/0)	
	Max. cable size, IP21/55/66 [mm ² (AWG ²⁾]	90 (3/0)		90 (3/0)		90 (3/0)		120 (4/0)		120 (4/0)	
	Max cable size with mains disconnect [mm ² (AWG ²⁾]			35 (2)				70 (3/0)		150 (300mcm)	
	Estimated power loss at rated max. load [W] ⁴⁾	570	698	697	843	891	1083	1022	1384	1232	1474
	Weight, enclosure IP21, IP55, 66 [kg]	45		45		45		65		65	
	Efficiency ⁴⁾	0.98		0.98		0.98		0.98		0.99	

Mains Supply 3 x 525 - 600V AC (FC 302 only)										
FC 302		PK75	P1K1	P1K5	P2K2	P3K0	P4K0	P5K5	P7K5	
	Typical Shaft Output [kW]	0.75	1.1	1.5	2.2	3	4	5.5	7.5	
	Enclosure IP20, 21	A3	A3	A3	A3	A3	A3	A3	A3	
	Enclosure IP55	A5	A5	A5	A5	A5	A5	A5	A5	
Output current										
	Continuous (3 x 525-550V) [A]	1.8	2.6	2.9	4.1	5.2	6.4	9.5	11.5	
	Intermittent (3 x 525-550V) [A]	2.9	4.2	4.6	6.6	8.3	10.2	15.2	18.4	
	Continuous (3 x 551-600V) [A]	1.7	2.4	2.7	3.9	4.9	6.1	9.0	11.0	
	Intermittent (3 x 551-600V) [A]	2.7	3.8	4.3	6.2	7.8	9.8	14.4	17.6	
	Continuous kVA (525 V AC) [kVA]	1.7	2.5	2.8	3.9	5.0	6.1	9.0	11.0	
	Continuous kVA (575V AC) [kVA]	1.7	2.4	2.7	3.9	4.9	6.1	9.0	11.0	
Max. input current										
	Continuous (3 x 525-600V) [A]	1.7	2.4	2.7	4.1	5.2	5.8	8.6	10.4	
	Intermittent (3 x 525-600V) [A]	2.7	3.8	4.3	6.6	8.3	9.3	13.8	16.6	
Additional specifications										
	Max. cable size (mains, motor, brake) [AWG] ²⁾ [mm ²]	24 - 10 AWG 0.2 - 4 mm ²					24 - 10 AWG 0.2 - 4 mm ²			
	Estimated power loss at rated max. load [W] ⁴⁾	35	50	65	92	122	145	195	261	
	Weight, Enclosure IP20 [kg]	6.5	6.5	6.5	6.5	6.5	6.5	6.6	6.6	
	Weight, enclosure IP55 [kg]	13.5	13.5	13.5	13.5	13.5	13.5	14.2	14.2	
	Efficiency ⁴⁾	0.97	0.97	0.97	0.97	0.97	0.97	0.97	0.97	

Mains Supply 3 x 525 - 600V AC											
FC 302	P11K		P15K		P18K		P22K		P30K		
High/ Normal Load ¹⁾	HO	NO	HO	NO	HO	NO	HO	NO	HO	NO	
Typical Shaft Output [kW]	11	15	15	18.5	18.5	22	22	30	30	37	
Enclosure IP21, 55, 66	B1		B1		B2		B2		C1		
	B3		B3		B4		B4		B4		
Output current											
Continuous (3 x 525-550V) [A]	19	23	23	28	28	36	36	43	43	54	
	30	25	37	31	45	40	58	47	65	59	
	18	22	22	27	27	34	34	41	41	52	
	29	24	35	30	43	37	54	45	62	57	
	18.1	21.9	21.9	26.7	26.7	34.3	34.3	41.0	41.0	51.4	
	17.9	21.9	21.9	26.9	26.9	33.9	33.9	40.8	40.8	51.8	
Max. input current											
Continuous at 550V [A]	17.2	20.9	20.9	25.4	25.4	32.7	32.7	39	39	49	
	28	23	33	28	41	36	52	43	59	54	
	16	20	20	24	24	31	31	37	37	47	
	26	22	32	27	39	34	50	41	56	52	
Additional specifications											
Max. cable size IP20 (mains, motor, load share and brake) [mm ² (AWG ²⁾]	16(6)				35(2)						
	16(6)				35(2)					90 (3/0)	
Max cable size with mains disconnect [mm ² (AWG ²⁾]	16(6)								35(2)		
Estimated power loss at rated max. load [W] ⁴⁾	225		285		329		700		700		
Weight, enclosure IP21, [kg]	23		23		27		27		27		
Weight, enclosure IP20 [kg]	12		12		23.5		23.5		23.5		
Efficiency ⁴⁾	0.98		0.98		0.98		0.98		0.98		

Mains Supply 3 x 525 - 600V AC									
FC 302		P37K		P45K		P55K		P75K	
High/ Normal Load*		HO	NO	HO	NO	HO	NO	HO	NO
	Typical Shaft Output [kW]	37	45	45	55	55	75	75	90
	Enclosure IP21, 55, 66	C1	C1	C1		C2		C2	
	Enclosure IP20	C3	C3	C3		C4		C4	
Output current									
	Continuous (3 x 525-550V) [A]	54	65	65	87	87	105	105	137
	Intermittent (3 x 525-550V) [A]	81	72	98	96	131	116	158	151
	Continuous (3 x 525-600V) [A]	52	62	62	83	83	100	100	131
	Intermittent (3 x 525-600V) [A]	78	68	93	91	125	110	150	144
	Continuous kVA (550V AC) [kVA]	51.4	61.9	61.9	82.9	82.9	100.0	100.0	130.5
	Continuous kVA (575V AC) [kVA]	51.8	61.7	61.7	82.7	82.7	99.6	99.6	130.5
Max. input current									
	Continuous at 550V [A]	49	59	59	78.9	78.9	95.3	95.3	124.3
	Intermittent at 550V [A]	74	65	89	87	118	105	143	137
	Continuous at 575V [A]	47	56	56	75	75	91	91	119
	Intermittent at 575V [A]	70	62	85	83	113	100	137	131
Additional specifications									
	Max. cable size IP20 (mains, motor) [mm ² (AWG ²⁾]	50 (1)				95 (4/0)		150 (300mcm)	
	Max. cable size IP20 (load share, brake) [AWG] ²⁾ [mm ²]	50 (1)				95 (4/0)			
	Max. cable size IP21, 55, 66 (mains, motor, load share and brake) [mm ² (AWG ²⁾]	90 (3/0)				120 (4/0)			
	Max cable size with mains disconnect	35 (2)				70 (3/0)		150 (300mcm)	
	Estimated power loss at rated max. load [W] ⁴⁾		850		1100		1400		1500
	Weight, enclosure IP20 [kg]	35		35		50		50	
	Weight, enclosure IP21, 55 [kg]	45		45		65		65	
	Efficiency ⁴⁾	0.98		0.98		0.98		0.98	

Mains Supply 3 x 525- 690V AC									
FC 302									
High/ Normal Load ¹⁾									
		P11K		P15K		P18K		P22K	
		HO	NO	HO	NO	HO	NO	HO	NO
Typical Shaft output at 550V [kW]		7.5	11	11	15	15	18.5	18.5	22
Typical Shaft output at 575V [HP]		11	15	15	20	20	25	25	30
Typical Shaft output at 690V [kW]		11	15	15	18.5	18.5	22	22	30
Enclosure IP21, 55		B2		B2		B2		B2	
Output current									
Continuous (3 x 525-550V) [A]		14	19	19	23	23	28	28	36
Intermittent (60 sec overload) (3 x 525-550V) [A]		22.4	20.9	30.4	25.3	36.8	30.8	44.8	39.6
Continuous (3 x 551-690V) [A]		13	18	18	22	22	27	27	34
Intermittent (60 sec overload) (3 x 551-690V) [A]		20.8	19.8	28.8	24.2	35.2	29.7	43.2	37.4
Continuous KVA (at 550V) [KVA]		13.3	18.1	18.1	21.9	21.9	26.7	26.7	34.3
Continuous KVA (at 575V) [KVA]		12.9	17.9	17.9	21.9	21.9	26.9	26.9	33.9
Continuous KVA (at 690V) [KVA]		15.5	21.5	21.5	26.3	26.3	32.3	32.3	40.6
Max. input current									
Continuous (3 x 525-690V) [A]		15	19.5	19.5	24	24	29	29	36
Intermittent (60 sec overload) (3 x 525-690V) [A]		23.2	21.5	31.2	26.4	38.4	31.9	46.4	39.6
Additional specifications									
Max. cable size, mains, motor, load share and brake [mm ² (AWG)]		35 (1/0)							
Estimated power loss at rated max. load [W] ⁴⁾		228		285		335		375	
Weight, enclosure IP21, IP55 [kg]		27							
Efficiency ⁴⁾		0.98		0.98		0.98		0.98	

Mains Supply 3 x 525- 690V AC											
FC 302		P30K		P37K		P45K		P55K		P75K	
High/ Normal Load*		HO	NO	HO	NO	HO	NO	HO	NO	HO	NO
	Typical Shaft output at 550V [kW]	22	30	30	37	37	45	45	55	55	75
	Typical Shaft output at 575V [HP]	30	40	40	50	50	60	60	75	75	100
	Typical Shaft output at 690V [kW]	30	37	37	45	45	55	55	75	75	90
	Enclosure IP21, 55	C2		C2		C2		C2		C2	
Output current											
	Continuous (3 x 525-550V) [A]	36	43	43	54	54	65	65	87	87	105
	Intermittent (60 sec overload) (3 x 525-550V) [A]	54	47.3	64.5	59.4	81	71.5	97.5	95.7	130.5	115.5
	Continuous (3 x 551-690V) [A]	34	41	41	52	52	62	62	83	83	100
	Intermittent (60 sec overload) (3 x 551-690V) [A]	51	45.1	61.5	57.2	78	68.2	93	91.3	124.5	110
	Continuous KVA (at 550V) [KVA]	34.3	41.0	41.0	51.4	51.4	61.9	61.9	82.9	82.9	100.0
	Continuous KVA (at 575V) [KVA]	33.9	40.8	40.8	51.8	51.8	61.7	61.7	82.7	82.7	99.6
	Continuous KVA (at 690V) [KVA]	40.6	49.0	49.0	62.1	62.1	74.1	74.1	99.2	99.2	119.5
Max. input current											
	Continuous (at 550V) [A]	36	49	49	59	59	71	71	87	87	99
	Continuous (at 575V) [A]	54	53.9	72	64.9	87	78.1	105	95.7	129	108.9
Additional specifications											
	Max. cable size, mains, motor, load share and brake [mm ² (AWG)]	95 (4/0)									
	Estimated power loss at rated max. load [W] ⁴⁾	480		592		720		880		1200	
	Weight, enclosure IP21, IP55 [kg]	65									
	Efficiency ⁴⁾	0.98		0.98		0.98		0.98		0.98	

For fuse ratings, see 10.3.1 Fuses

1) High overload = 160% torque during 60 sec., Normal overload = 110% torque during 60 sec.

2) American Wire Gauge.

3) Measured using 5 m screened motor cables at rated load and rated frequency.

4) The typical power loss is at nominal load conditions and expected to be within +/-15% (tolerance relates to variety in voltage and cable conditions).

Values are based on a typical motor efficiency (eff2/eff3 border line). Motors with lower efficiency will also add to the power loss in the frequency converter and opposite.

If the switching frequency is increased compared to the default setting, the power losses may rise significantly.

LCP and typical control card power consumptions are included. Further options and customer load may add up to 30W to the losses. (Though typical only 4W extra for a fully loaded control card, or options for slot A or slot B, each).

Although measurements are made with state of the art equipment, some measurement inaccuracy must be allowed for (+/-5%).

10.2 General Technical Data

Mains supply (L1, L2, L3):

Supply voltage	200-240 V ±10%
Supply voltage	FC 301: 380-480 V / FC 302: 380-500 V ±10%
	FC 302: 525-600 V ±10%
Supply voltage	FC 302: 525-690 V ±10%

Mains voltage low / mains drop-out:

During low mains voltage or a mains drop-out, the FC continues until the intermediate circuit voltage drops below the minimum stop level, which corresponds typically to 15% below the frequency converter's lowest rated supply voltage. Power-up and full torque cannot be expected at mains voltage lower than 10% below the frequency converter's lowest rated supply voltage.

Supply frequency	50/60 Hz ±5%
Max. imbalance temporary between mains phases	3.0 % of rated supply voltage
True Power Factor (λ)	≥ 0.9 nominal at rated load
Displacement Power Factor ($\cos \phi$)	near unity (> 0.98)
Switching on input supply L1, L2, L3 (power-ups) ≤ 7.5 kW	maximum 2 times/min.
Switching on input supply L1, L2, L3 (power-ups) 11-75 kW	maximum 1 time/min.
Switching on input supply L1, L2, L3 (power-ups) ≥ 90 kW	maximum 1 time/2 min.
Environment according to EN60664-1	overvoltage category III/pollution degree 2

The unit is suitable for use on a circuit capable of delivering not more than 100,000 RMS symmetrical Amperes, 240/500/600/ 690 V maximum.

Motor output (U, V, W):

Output voltage	0 - 100% of supply voltage
Output frequency (0.25-75kW)	FC 301: 0.2 - 1000Hz / FC 302: 0 - 1000Hz
Output frequency (90-1000kW)	0 - 800 ¹⁾ Hz
Output frequency in Flux Mode (FC 302 only)	0 - 300Hz
Switching on output	Unlimited
Ramp times	0.01 - 3600sec.

¹⁾ Voltage and power dependent

Torque characteristics:

Starting torque (Constant torque)	maximum 160% for 60 sec. ¹⁾
Starting torque	maximum 180% up to 0.5 sec. ¹⁾
Overload torque (Constant torque)	maximum 160% for 60 sec. ¹⁾
Starting torque (Variable torque)	maximum 110% for 60 sec. ¹⁾
Overload torque (Variable torque)	maximum 110% for 60 sec.

Torque rise time in (independent of fsw) 10ms

Torque rise time in FLUX (for 5kHz fsw) 1ms

¹⁾ Percentage relates to the nominal torque.

²⁾ The torque response time depends on application and load but as a general rule, the torque step from 0 to reference is 4-5 x torque rise time.

Digital inputs:

Programmable digital inputs	FC 301: 4 (5) ¹⁾ / FC 302: 4 (6) ¹⁾
Terminal number	18, 19, 27 ¹⁾ , 29 ¹⁾ , 32, 33,
Logic	PNP or NPN
Voltage level	0 - 24V DC
Voltage level, logic '0' PNP	< 5V DC
Voltage level, logic '1' PNP	> 10V DC
Voltage level, logic '0' NPN ²⁾	> 19V DC
Voltage level, logic '1' NPN ²⁾	< 14V DC
Maximum voltage on input	28V DC
Pulse frequency range	0 - 110kHz
(Duty cycle) Min. pulse width	4.5ms
Input resistance, R _i	approx. 4 kΩ

Safe stop Terminal 37^{3, 4)} (Terminal 37 is fixed PNP logic):

Voltage level	0 - 24V DC
Voltage level, logic'0' PNP	< 4V DC
Voltage level, logic'1' PNP	>20V DC
Maximum voltage on input	28V DC
Nominal input current at 24V	50mA rms
Nominal input current at 20V	60mA rms
Input capacitance	400nF

All digital inputs are galvanically isolated from the supply voltage (PELV) and other high-voltage terminals.

¹⁾ Terminals 27 and 29 can also be programmed as output.

²⁾ Except safe stop input Terminal 37.

³⁾ Terminal 37 is only available in FC 302 and FC 301 A1 with Safe Stop. It can only be used as safe stop input. Terminal 37 is suitable for PL d (ISO13849-1), SIL 2 (IEC 61508) and SILCL 2 (EN 62061) and implements a Safe Stop function in accordance with Safe Torque Off (STO, EN 61800-5-2) and Stop Category 0 (EN 60204-1). Terminal 37 and the Safe Stop function are designed in conformance with EN 60204-1, EN 61800-5-1, EN 61800-2, EN 61800-3, and EN 954-1. For correct and safe use of the Safe Stop function follow the related information and instructions in the Design Guide.

⁴⁾ When using a contactor with a DC coil inside in combination with Safe Stop, it is important to make a return way for the current from the coil when turning it off. This can be done by using a freewheel diode (or, alternatively, a 30 or 50 V MOV for quicker response time) across the coil. Typical contactors can be bought with this diode.

Analog inputs:

Number of analog inputs	2
Terminal number	53, 54
Modes	Voltage or current
Mode select	Switch S201 and switch S202
Voltage mode	Switch S201/switch S202 = OFF (U)
Voltage level	FC 301: 0 to + 10/ FC 302: -10 to +10 V (scaleable)
Input resistance, R _i	approx. 10 kΩ
Max. voltage	± 20 V
Current mode	Switch S201/switch S202 = ON (I)
Current level	0/4 to 20 mA (scaleable)
Input resistance, R _i	approx. 200 Ω
Max. current	30 mA
Resolution for analog inputs	10 bit (+ sign)
Accuracy of analog inputs	Max. error 0.5% of full scale
Bandwidth	FC 301: 20 Hz/ FC 302: 100 Hz

The analog inputs are galvanically isolated from the supply voltage (PELV) and other high-voltage terminals.

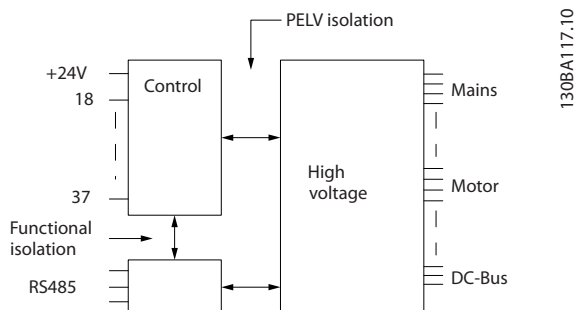

Pulse/encoder inputs:

Programmable pulse/encoder inputs	2/1
Terminal number pulse/encoder	29 ¹⁾ , 33 ²⁾ / 32 ³⁾ , 33 ³⁾
Max. frequency at terminal 29, 32, 33	110kHz (Push-pull driven)
Max. frequency at terminal 29, 32, 33	5kHz (open collector)
Min. frequency at terminal 29, 32, 33	4Hz
Voltage level	see section on Digital input

Maximum voltage on input	28V DC
Input resistance, R_i	approx. $4k\Omega$
Pulse input accuracy (0.1 - 1kHz)	Max. error: 0.1% of full scale
Encoder input accuracy (1 - 11 kHz)	Max. error: 0.05 % of full scale

The pulse and encoder inputs (terminals 29, 32, 33) are galvanically isolated from the supply voltage (PELV) and other high-voltage terminals.

¹⁾ FC 302 only

²⁾ Pulse inputs are 29 and 33

³⁾ Encoder inputs: 32 = A, and 33 = B

Digital output:

Programmable digital/pulse outputs	2
Terminal number	27, 29 ¹⁾
Voltage level at digital/frequency output	0 - 24V
Max. output current (sink or source)	40mA
Max. load at frequency output	$1k\Omega$
Max. capacitive load at frequency output	10nF
Minimum output frequency at frequency output	0Hz
Maximum output frequency at frequency output	32kHz
Accuracy of frequency output	Max. error: 0.1 % of full scale
Resolution of frequency outputs	12 bit

¹⁾ Terminal 27 and 29 can also be programmed as input.

The digital output is galvanically isolated from the supply voltage (PELV) and other high-voltage terminals.

Analog output:

Number of programmable analog outputs	1
Terminal number	42
Current range at analog output	0/4 - 20mA
Max. load GND - analog output	500Ω
Accuracy on analog output	Max. error: 0.5% of full scale
Resolution on analog output	12 bit

The analogue output is galvanically isolated from the supply voltage (PELV) and other high-voltage terminals.

Control card, 24 V DC output:

Terminal number	12, 13
Output voltage	24 V +1, -3 V
Max. load	FC 301: 130 mA/ FC 302: 200 mA

The 24 V DC supply is galvanically isolated from the supply voltage (PELV), but has the same potential as the analog and digital inputs and outputs.

Control card, 10V DC output:

Terminal number	50
Output voltage	$10.5V \pm 0.5V$
Max. load	15 mA

The 10V DC supply is galvanically isolated from the supply voltage (PELV) and other high-voltage terminals.

Control card, RS-485 serial communication:

Terminal number	68 (P,TX+, RX+), 69 (N,TX-, RX-)
Terminal number 61	Common for terminals 68 and 69

The RS-485 serial communication circuit is functionally separated from other central circuits and galvanically isolated from the supply voltage (PELV).

Control card, USB serial communication:

USB standard	1.1 (Full speed)
USB plug	USB type B "device" plug

Connection to PC is carried out via a standard host/device USB cable.

The USB connection is galvanically isolated from the supply voltage (PELV) and other high-voltage terminals.

The USB ground connection is not galvanically isolated from protection earth. Use only an isolated laptop as PC connection to the USB connector on the frequency converter.

Relay outputs:

Programmable relay outputs	FC 301 all kW: 1 / FC 302 all kW: 2
Relay 01 Terminal number	1-3 (break), 1-2 (make)
Max. terminal load (AC-1) ¹⁾ on 1-3 (NC), 1-2 (NO) (Resistive load)	240V AC, 2A
Max. terminal load (AC-15) ¹⁾ (Inductive load @ cosφ 0.4)	240V AC, 0.2A
Max. terminal load (DC-1) ¹⁾ on 1-2 (NO), 1-3 (NC) (Resistive load)	60V DC, 1A
Max. terminal load (DC-13) ¹⁾ (Inductive load)	24V DC, 0.1A
Relay 02 (FC 302 only) Terminal number	4-6 (break), 4-5 (make)
Max. terminal load (AC-1) ¹⁾ on 4-5 (NO) (Resistive load) ²⁾³⁾ Overvoltage cat. II	400V AC, 2A
Max. terminal load (AC-15) ¹⁾ on 4-5 (NO) (Inductive load @ cosφ 0.4)	240V AC, 0.2A
Max. terminal load (DC-1) ¹⁾ on 4-5 (NO) (Resistive load)	80V DC, 2A
Max. terminal load (DC-13) ¹⁾ on 4-5 (NO) (Inductive load)	24V DC, 0.1A
Max. terminal load (AC-1) ¹⁾ on 4-6 (NC) (Resistive load)	240V AC, 2A
Max. terminal load (AC-15) ¹⁾ on 4-6 (NC) (Inductive load @ cosφ 0.4)	240V AC, 0.2A
Max. terminal load (DC-1) ¹⁾ on 4-6 (NC) (Resistive load)	50V DC, 2A
Max. terminal load (DC-13) ¹⁾ on 4-6 (NC) (Inductive load)	24V DC, 0.1A
Min. terminal load on 1-3 (NC), 1-2 (NO), 4-6 (NC), 4-5 (NO)	24V DC 10mA, 24V AC 20mA
Environment according to EN 60664-1	overvoltage category III/pollution degree 2

¹⁾ IEC 60947 part 4 and 5

The relay contacts are galvanically isolated from the rest of the circuit by reinforced isolation (PELV).

²⁾ Overvoltage Category II

³⁾ UL applications 300V AC2A

Cable lengths and cross sections for control cables¹⁾:

Max. motor cable length, screened	FC 301: 50m/FC 301 (A1): 25m/ FC 302: 150m
Max. motor cable length, unscreened	FC 301: 75m/FC 301 (A1): 50 m/ FC 302: 300m
Maximum cross section to control terminals, flexible/ rigid wire without cable end sleeves	1.5mm ² /16 AWG
Maximum cross section to control terminals, flexible wire with cable end sleeves	1mm ² /18 AWG
Maximum cross section to control terminals, flexible wire with cable end sleeves with collar	0.5mm ² /20 AWG
Minimum cross section to control terminals	0.25mm ² / 24AWG

¹⁾Power cables, see tables in 10.1 Power-dependent Specifications.

Control card performance:

Scan interval	FC 301: 5 ms / FC 302: 1 ms
---------------	-----------------------------

Control characteristics:

Resolution of output frequency at 0 - 1000Hz	± 0.003Hz
Repeat accuracy of <i>Precise start/stop</i> (terminals 18, 19)	≤± 0.1msec
System response time (terminals 18, 19, 27, 29, 32, 33)	≤ 2ms
Speed control range (open loop)	1:100 of synchronous speed
Speed control range (closed loop)	1:1000 of synchronous speed
Speed accuracy (open loop)	30 - 4000rpm: error ±8rpm
Speed accuracy (closed loop), depending on resolution of feedback device	0 - 6000rpm: error ±0.15rpm
Torque control accuracy (speed feedback)	max error±5% of rated torque

All control characteristics are based on a 4-pole asynchronous motor

Environment:

Enclosure	IP20 ¹⁾ / Type 1, IP21 ²⁾ / Type 1, IP55/ Type 12, IP 66
Vibration test	1.0g
Max. relative humidity	5% - 93%(IEC 721-3-3; Class 3K3 (non-condensing) during operation
Aggressive environment (IEC 60068-2-43) H ₂ S test	class Kd
Ambient temperature ³⁾	Max. 50°C (24-hour average maximum 45°C)

¹⁾ Only for ≤ 3.7kW (200 - 240V), ≤ 7.5kW (400 - 480/ 500V)

²⁾ As enclosure kit for ≤ 3.7kW (200 - 240V), ≤ 7.5kW (400 - 480/ 500V)

³⁾ Derating for high ambient temperature, see special conditions in the Design Guide

Minimum ambient temperature during full-scale operation	0°C
Minimum ambient temperature at reduced performance	- 10°C
Temperature during storage/transport	-25 - +65/70°C
Maximum altitude above sea level without derating	1000m

Derating for high altitude, see special conditions in the Design Guide

EMC standards, Emission EN 61800-3, EN 61000-6-3/4, EN 55011

EN 61800-3, EN 61000-6-1/2,

EMC standards, Immunity EN 61000-4-2, EN 61000-4-3, EN 61000-4-4, EN 61000-4-5, EN 61000-4-6

See section on special conditions in the Design Guide.

Protection and Features:

- Electronic thermal motor protection against overload.
- Temperature monitoring of the heatsink ensures that the frequency converter trips if the temperature reaches a predefined level. An overload temperature cannot be reset until the temperature of the heatsink is below the values stated in the tables on the following pages (Guideline - these temperatures may vary for different power sizes, frame sizes, enclosure ratings etc.).
- The frequency converter is protected against short-circuits on motor terminals U, V, W.
- If a mains phase is missing, the frequency converter trips or issues a warning (depending on the load).
- Monitoring of the intermediate circuit voltage ensures that the frequency converter trips if the intermediate circuit voltage is too low or too high.
- The frequency converter constantly checks for critical levels of internal temperature, load current, high voltage on the intermediate circuit and low motor speeds. As a response to a critical level, the frequency converter can adjust the switching frequency and/ or change the switching pattern in order to ensure the performance of the frequency converter.

10.3 Fuse Tables

It is recommended to use fuses and/ or Circuit Breakers on the supply side as protection in case of component break-down inside the frequency converter (first fault).

NOTE

This is mandatory in order to ensure compliance with IEC 60364 for CE or NEC 2009 for UL.

⚠ WARNING

Personnel and property must be protected against the consequence of component break-down internally in the frequency converter.

Branch Circuit Protection

In order to protect the installation against electrical and fire hazard, all branch circuits in an installation, switch gear, machines etc., must be protected against short-circuit and over-current according to national/international regulations.

NOTE

The recommendations given do not cover Branch circuit protection for UL!

Short-circuit protection:

Danfoss recommends using the fuses/Circuit Breakers mentioned below to protect service personnel and property in case of component break-down in the frequency converter.

Over current protection:

The frequency converter provides overload protection to limit threats to human life, property damage and to avoid fire hazard due to overheating of the cables in the installation. The frequency converter is equipped with an internal over current protection (*4-18 Current Limit*) that can be used for upstream overload protection (UL-applications excluded). Moreover, fuses or Circuit Breakers can be used to provide the over current protection in the installation. Over current protection must always be carried out according to national regulations.

10.3.1 Recommendations

⚠ WARNING

In case of malfunction, not following the recommendation may result in personnel risk and damage to the frequency converter and other equipment.

The following tables list the recommended rated current. Recommended fuses are of the type gG for small to medium power sizes. For larger powers, aR fuses are recommended. For Circuit Breakers, Moeller types have been tested to have

a recommendation. Other types of circuit breakers may be used provide they limit the energy into the frequency converter to a level equal to or lower than the Moeller types.

If fuses/Circuit Breakers according to recommendations are chosen, possible damages on the frequency converter will mainly be limited to damages inside the unit.

For further information please see Application Note *Fuses and Circuit Breakers*, MN.90.TX.YY

10.3.2 CE Compliance

Fuses or Circuit Breakers are mandatory to comply with IEC 60364. Danfoss recommend using a selection of the following.

The fuses below are suitable for use on a circuit capable of delivering 100,000 Arms (symmetrical), 240V, or 480V, or 500V, or 600V depending on the frequency converter voltage rating. With the proper fusing the frequency converter short circuit current rating (SCCR) is 100,000 Arms.

Enclosure	FC 300 Power	Recommended fuse size	Recommended Max. fuse	Recommended circuit breaker	Max trip level
Size	[kW]			Moeller	[A]
A1	0.25-1.5	gG-10	gG-25	PKZM0-16	16
A2	0.25-2.2	gG-10 (0.25-1.5) gG-16 (2.2)	gG-25	PKZM0-25	25
A3	3.0-3.7	gG-16 (3) gG-20 (3.7)	gG-32	PKZM0-25	25
B3	5.5	gG-25	gG-63	PKZM4-50	50
B4	7.5-15	gG-32 (7.5) gG-50 (11) gG-63 (15)	gG-125	NZMB1-A100	100
C3	18.5-22	gG-80 (18.5) aR-125 (22)	gG-150 (18.5) aR-160 (22)	NZMB2-A200	150
C4	30-37	aR-160 (30) aR-200 (37)	aR-200 (30) aR-250 (37)	NZMB2-A250	250
A4	0.25-2.2	gG-10 (0.25-1.5) gG-16 (2.2)	gG-32	PKZM0-25	25
A5	0.25-3.7	gG-10 (0.25-1.5) gG-16 (2.2-3) gG-20 (3.7)	gG-32	PKZM0-25	25
B1	5.5-7.5	gG-25 (5.5) gG-32 (7.5)	gG-80	PKZM4-63	63
B2	11	gG-50	gG-100	NZMB1-A100	100
C1	15-22	gG-63 (15) gG-80 (18.5) gG-100 (22)	gG-160 (15-18.5) aR-160 (22)	NZMB2-A200	160
C2	30-37	aR-160 (30) aR-200 (37)	aR-200 (30) aR-250 (37)	NZMB2-A250	250

Table 10.1 200-240V, Frame Sizes A, B, and C

Enclosure	FC 300 Power	Recommended fuse size	Recommended Max. fuse	Recommended circuit breaker	Max trip level
Size	[kW]			Moeller	[A]
A1	0.37-1.5	gG-10	gG-25	PKZM0-16	16
A2	0.37-4.0	gG-10 (0.37-3) gG-16 (4)	gG-25	PKZM0-25	25
A3	5.5-7.5	gG-16	gG-32	PKZM0-25	25
B3	11-15	gG-40	gG-63	PKZM4-50	50
B4	18.5-30	gG-50 (18.5) gG-63 (22) gG-80 (30)	gG-125	NZMB1-A100	100
C3	37-45	gG-100 (37) gG-160 (45)	gG-150 (37) gG-160 (45)	NZMB2-A200	150
C4	55-75	aR-200 (55) aR-250 (75)	aR-250	NZMB2-A250	250
A4	0.37-4	gG-10 (0.37-3) gG-16 (4)	gG-32	PKZM0-25	25
A5	0.37-7.5	gG-10 (0.37-3) gG-16 (4-7.5)	gG-32	PKZM0-25	25
B1	11-15	gG-40	gG-80	PKZM4-63	63
B2	18.5-22	gG-50 (18.5) gG-63 (22)	gG-100	NZMB1-A100	100
C1	30-45	gG-80 (30) gG-100 (37) gG-160 (45)	gG-160	NZMB2-A200	160
C2	55-75	aR-200 (55) aR-250 (75)	aR-250	NZMB2-A250	250
D	90-200	gG-300 (90) gG-350 (110) gG-400 (132) gG-500 (160) gG-630 (200)	gG-300 (90) gG-350 (110) gG-400 (132) gG-500 (160) gG-630 (200)	-	-
E	250-400	aR-700 (250) aR-900 (315-400)	aR-700 (250) aR-900 (315-400)	-	-
F	450-800	aR-1600 (450-500) aR-2000 (560-630) aR-2500 (710-800)	aR-1600 (450-500) aR-2000 (560-630) aR-2500 (710-800)	-	-

Table 10.2 380-500V, Frame Sizes A, B, C, D, E, and F

Enclosure	FC 300 Power	Recommended fuse size	Recommended Max. fuse	Recommended circuit breaker	Max trip level
Size	[kW]			Moeller	[A]
A2	0-7.5-4.0	gG-10	gG-25	PKZM0-25	25
A3	5.5-7.5	gG-10 (5.5) gG-16 (7.5)	gG-32	PKZM0-25	25
B3	11-15	gG-25 (11) gG-32 (15)	gG-63	PKZM4-50	50
B4	18.5-30	gG-40 (18.5) gG-50 (22) gG-63 (30)	gG-125	NZMB1-A100	100
C3	37-45	gG-63 (37) gG-100 (45)	gG-150	NZMB2-A200	150
C4	55-75	aR-160 (55) aR-200 (75)	aR-250	NZMB2-A250	250
A5	0.75-7.5	gG-10 (0.75-5.5) gG-16 (7.5)	gG-32	PKZM0-25	25
B1	11-18	gG-25 (11) gG-32 (15) gG-40 (18.5)	gG-80	PKZM4-63	63
B2	22-30	gG-50 (22) gG-63 (30)	gG-100	NZMB1-A100	100
C1	37-55	gG-63 (37) gG-100 (45) aR-160 (55)	gG-160 (37-45) aR-250 (55)	NZMB2-A200	160
C2	75	aR-200 (75)	aR-250	NZMB2-A250	250

Table 10.3 525-600V, Frame Sizes A, B, and C
10

Enclosure	FC 300 Power	Recommended fuse size	Recommended Max. fuse	Recommended circuit breaker	Max trip level
Size	[kW]			Moeller	[A]
B2	11 15 18 22	gG-25 (11) gG-32 (15) gG-32 (18) gG-40 (22)	gG-63	-	-
C2	30 37 45 55 75	gG-63 (30) gG-63 (37) gG-80 (45) gG-100 (55) gG-125 (75)	gG-80 (30) gG-100 (37) gG-125 (45) gG-160 (55-75)	-	-
D	37-315	gG-125 (37) gG-160 (45) gG-200 (55-75) aR-250 (90) aR-315 (110) aR-350 (132-160) aR-400 (200) aR-500 (250) aR-550 (315)	gG-125 (37) gG-160 (45) gG-200 (55-75) aR-250 (90) aR-315 (110) aR-350 (132-160) aR-400 (200) aR-500 (250) aR-550 (315)	-	-
E	355-560	aR-700 (355-400) aR-900 (500-560)	aR-700 (355-400) aR-900 (500-560)	-	-
F	630-1200	aR-1600 (630-900) aR-2000 (1000) aR-2500 (1200)	aR-1600 (630-900) aR-2000 (1000) aR-2500 (1200)	-	-

Table 10.4 525-690V, Frame Sizes B, C, D, E, and F

UL Compliance

Fuses or Circuit Breakers are mandatory to comply with NEC 2009. We recommend using a selection of the following

The fuses below are suitable for use on a circuit capable of delivering 100,000 Arms (symmetrical), 240V, or 480V, or 500V, or 600V depending on the frequency converter voltage rating. With the proper fusing the drive Short Circuit Current Rating (SCCR) is 100,000 Arms.

FC 300 Power	Recommended max. fuse					
	Bussmann	Bussmann	Bussmann	Bussmann	Bussmann	Bussmann
[kW]	Type RK1 ¹⁾	Type J	Type T	Type CC	Type CC	Type CC
0.25-0.37	KTN-R-05	JKS-05	JJN-05	FNQ-R-5	KTK-R-5	LP-CC-5
0.55-1.1	KTN-R-10	JKS-10	JJN-10	FNQ-R-10	KTK-R-10	LP-CC-10
1.5	KTN-R-15	JKS-15	JJN-15	FNQ-R-15	KTK-R-15	LP-CC-15
2.2	KTN-R-20	JKS-20	JJN-20	FNQ-R-20	KTK-R-20	LP-CC-20
3.0	KTN-R-25	JKS-25	JJN-25	FNQ-R-25	KTK-R-25	LP-CC-25
3.7	KTN-R-30	JKS-30	JJN-30	FNQ-R-30	KTK-R-30	LP-CC-30
5.5	KTN-R-50	KS-50	JJN-50	-	-	-
7.5	KTN-R-60	JKS-60	JJN-60	-	-	-
11	KTN-R-80	JKS-80	JJN-80	-	-	-
15-18.5	KTN-R-125	JKS-125	JJN-125	-	-	-
22	KTN-R-150	JKS-150	JJN-150	-	-	-
30	KTN-R-200	JKS-200	JJN-200	-	-	-
37	KTN-R-250	JKS-250	JJN-250	-	-	-

Table 10.5 200-240V, Frame Sizes A, B, and C

FC 300 Power	Recommended max. fuse			
	SIBA	Littel fuse	Ferraz-Shawmut	Ferraz-Shawmut
[kW]	Type RK1	Type RK1	Type CC	Type RK1 ³⁾
0.25-0.37	5017906-005	KLN-R-05	ATM-R-05	A2K-05-R
0.55-1.1	5017906-010	KLN-R-10	ATM-R-10	A2K-10-R
1.5	5017906-016	KLN-R-15	ATM-R-15	A2K-15-R
2.2	5017906-020	KLN-R-20	ATM-R-20	A2K-20-R
3.0	5017906-025	KLN-R-25	ATM-R-25	A2K-25-R
3.7	5012406-032	KLN-R-30	ATM-R-30	A2K-30-R
5.5	5014006-050	KLN-R-50	-	A2K-50-R
7.5	5014006-063	KLN-R-60	-	A2K-60-R
11	5014006-080	KLN-R-80	-	A2K-80-R
15-18.5	2028220-125	KLN-R-125	-	A2K-125-R
22	2028220-150	KLN-R-150	-	A2K-150-R
30	2028220-200	KLN-R-200	-	A2K-200-R
37	2028220-250	KLN-R-250	-	A2K-250-R

Table 10.6 200-240V, Frame Sizes A, B, and C

FC 300	Recommended max. fuse			
	Bussmann	Littel fuse	Ferraz-Shawmut	Ferraz-Shawmut
[kW]	Type JFHR2 ²⁾	JFHR2	Type JFHR2 ⁴⁾	J
0.25-0.37	FWX-5	-	-	HSJ-6
0.55-1.1	FWX-10	-	-	HSJ-10
1.5	FWX-15	-	-	HSJ-15
2.2	FWX-20	-	-	HSJ-20
3.0	FWX-25	-	-	HSJ-25
3.7	FWX-30	-	-	HSJ-30
5.5	FWX-50	-	-	HSJ-50
7.5	FWX-60	-	-	HSJ-60
11	FWX-80	-	-	HSJ-80
15-18.5	FWX-125	-	-	HSJ-125
22	FWX-150	L25S-150	A25X-150	HSJ-150
30	FWX-200	L25S-200	A25X-200	HSJ-200
37	FWX-250	L25S-250	A25X-250	HSJ-250

Table 10.7 200-240V, Frame Sizes A, B, and C

- 1) KTS-fuses from Bussmann may substitute KTN for 240V frequency converters.
- 2) FWH-fuses from Bussmann may substitute FWX for 240V frequency converters.
- 3) A6KR fuses from FERRAZ SHAWMUT may substitute A2KR for 240V frequency converters.
- 4) A50X fuses from FERRAZ SHAWMUT may substitute A25X for 240V frequency converters.

FC 300	Recommended max. fuse					
	Bussmann	Bussmann	Bussmann	Bussmann	Bussmann	Bussmann
[kW]	Type RK1	Type J	Type T	Type CC	Type CC	Type CC
0.37-1.1	KTS-R-6	JKS-6	JJS-6	FNQ-R-6	KTK-R-6	LP-CC-6
1.5-2.2	KTS-R-10	JKS-10	JJS-10	FNQ-R-10	KTK-R-10	LP-CC-10
3	KTS-R-15	JKS-15	JJS-15	FNQ-R-15	KTK-R-15	LP-CC-15
4	KTS-R-20	JKS-20	JJS-20	FNQ-R-20	KTK-R-20	LP-CC-20
5.5	KTS-R-25	JKS-25	JJS-25	FNQ-R-25	KTK-R-25	LP-CC-25
7.5	KTS-R-30	JKS-30	JJS-30	FNQ-R-30	KTK-R-30	LP-CC-30
11	KTS-R-40	JKS-40	JJS-40	-	-	-
15	KTS-R-50	JKS-50	JJS-50	-	-	-
18	KTS-R-60	JKS-60	JJS-60	-	-	-
22	KTS-R-80	JKS-80	JJS-80	-	-	-
30	KTS-R-100	JKS-100	JJS-100	-	-	-
37	KTS-R-125	JKS-125	JJS-125	-	-	-
45	KTS-R-150	JKS-150	JJS-150	-	-	-
55	KTS-R-200	JKS-200	JJS-200	-	-	-
75	KTS-R-250	JKS-250	JJS-250	-	-	-

Table 10.8 380-500V, Frame Sizes A, B, and C

FC 302	Recommended max. fuse			
	SIBA	Littel fuse	Ferraz-Shawmut	Ferraz-Shawmut
[kW]	Type RK1	Type RK1	Type CC	Type RK1
0.37-1.1	5017906-006	KLS-R-6	ATM-R-6	A6K-6-R
1.5-2.2	5017906-010	KLS-R-10	ATM-R-10	A6K-10-R
3	5017906-016	KLS-R-15	ATM-R-15	A6K-15-R
4	5017906-020	KLS-R-20	ATM-R-20	A6K-20-R
5.5	5017906-025	KLS-R-25	ATM-R-25	A6K-25-R
7.5	5012406-032	KLS-R-30	ATM-R-30	A6K-30-R
11	5014006-040	KLS-R-40	-	A6K-40-R
15	5014006-050	KLS-R-50	-	A6K-50-R
18	5014006-063	KLS-R-60	-	A6K-60-R
22	2028220-100	KLS-R-80	-	A6K-80-R
30	2028220-125	KLS-R-100	-	A6K-100-R
37	2028220-125	KLS-R-125	-	A6K-125-R
45	2028220-160	KLS-R-150	-	A6K-150-R
55	2028220-200	KLS-R-200	-	A6K-200-R
75	2028220-250	KLS-R-250	-	A6K-250-R

Table 10.9 380-500V, Frame Sizes A, B, and C

FC 302	Recommended max. fuse			
	Bussmann	Ferraz-Shawmut	Ferraz-Shawmut	Littel fuse
[kW]	JFHR2	J	JFHR2 ¹⁾	JFHR2
0.37-1.1	FWH-6	HSJ-6	-	-
1.5-2.2	FWH-10	HSJ-10	-	-
3	FWH-15	HSJ-15	-	-
4	FWH-20	HSJ-20	-	-
5.5	FWH-25	HSJ-25	-	-
7.5	FWH-30	HSJ-30	-	-
11	FWH-40	HSJ-40	-	-
15	FWH-50	HSJ-50	-	-
18	FWH-60	HSJ-60	-	-
22	FWH-80	HSJ-80	-	-
30	FWH-100	HSJ-100	-	-
37	FWH-125	HSJ-125	-	-
45	FWH-150	HSJ-150	-	-
55	FWH-200	HSJ-200	A50-P-225	L50-S-225
75	FWH-250	HSJ-250	A50-P-250	L50-S-250

Table 10.10 380-500V, Frame Sizes A, B, and C

1) Ferraz-Shawmut A50QS fuses may substitute for A50P fuses.

FC 302	Recommended max. fuse					
	Bussmann	Bussmann	Bussmann	Bussmann	Bussmann	Bussmann
[kW]	Type RK1	Type J	Type T	Type CC	Type CC	Type CC
0.75-1.1	KTS-R-5	JKS-5	JJS-6	FNQ-R-5	KTK-R-5	LP-CC-5
1.5-2.2	KTS-R-10	JKS-10	JJS-10	FNQ-R-10	KTK-R-10	LP-CC-10
3	KTS-R-15	JKS-15	JJS-15	FNQ-R-15	KTK-R-15	LP-CC-15
4	KTS-R-20	JKS-20	JJS-20	FNQ-R-20	KTK-R-20	LP-CC-20
5.5	KTS-R-25	JKS-25	JJS-25	FNQ-R-25	KTK-R-25	LP-CC-25
7.5	KTS-R-30	JKS-30	JJS-30	FNQ-R-30	KTK-R-30	LP-CC-30
11	KTS-R-35	JKS-35	JJS-35	-	-	-
15	KTS-R-45	JKS-45	JJS-45	-	-	-
18	KTS-R-50	JKS-50	JJS-50	-	-	-
22	KTS-R-60	JKS-60	JJS-60	-	-	-
30	KTS-R-80	JKS-80	JJS-80	-	-	-
37	KTS-R-100	JKS-100	JJS-100	-	-	-
45	KTS-R-125	JKS-125	JJS-125	-	-	-
55	KTS-R-150	JKS-150	JJS-150	-	-	-
75	KTS-R-175	JKS-175	JJS-175	-	-	-

Table 10.11 525-600V, Frame Sizes A, B, and C

FC 302	Recommended max. fuse			
	SIBA	Littel fuse	Ferraz-Shawmut	Ferraz-Shawmut
[kW]	Type RK1	Type RK1	Type RK1	J
0.75-1.1	5017906-005	KLS-R-005	A6K-5-R	HSJ-6
1.5-2.2	5017906-010	KLS-R-010	A6K-10-R	HSJ-10
3	5017906-016	KLS-R-015	A6K-15-R	HSJ-15
4	5017906-020	KLS-R-020	A6K-20-R	HSJ-20
5.5	5017906-025	KLS-R-025	A6K-25-R	HSJ-25
7.5	5017906-030	KLS-R-030	A6K-30-R	HSJ-30
11	5014006-040	KLS-R-035	A6K-35-R	HSJ-35
15	5014006-050	KLS-R-045	A6K-45-R	HSJ-45
18	5014006-050	KLS-R-050	A6K-50-R	HSJ-50
22	5014006-063	KLS-R-060	A6K-60-R	HSJ-60
30	5014006-080	KLS-R-075	A6K-80-R	HSJ-80
37	5014006-100	KLS-R-100	A6K-100-R	HSJ-100
45	2028220-125	KLS-R-125	A6K-125-R	HSJ-125
55	2028220-150	KLS-R-150	A6K-150-R	HSJ-150
75	2028220-200	KLS-R-175	A6K-175-R	HSJ-175

Table 10.12 525-600V, Frame Sizes A, B, and C

¹⁾ 170M fuses shown from Bussmann use the -/80 visual indicator. -TN/80 Type T, -/110 or TN/110 Type T indicator fuses of the same size and amperage may be substituted.

FC 302 [kW]	Max. prefuse	Recommended max. fuse						
		Bussmann E52273 RK1/JDDZ	Bussmann E4273 J/JDDZ	Bussmann E4273 T/JDDZ	SIBA E180276 RK1/JDDZ	Littelfuse E81895 RK1/JDDZ	Ferraz-Shawmut E163267/E2137 RK1/JDDZ	Ferraz-Shawmut E2137 J/HSJ
11	30 A	KTS-R-30	JKS-30	JKJS-30	5017906-030	KLS-R-030	A6K-30-R	HST-30
15-18.5	45 A	KTS-R-45	JKS-45	JJS-45	5014006-050	KLS-R-045	A6K-45-R	HST-45
22	60 A	KTS-R-60	JKS-60	JJS-60	5014006-063	KLS-R-060	A6K-60-R	HST-60
30	80 A	KTS-R-80	JKS-80	JJS-80	5014006-080	KLS-R-075	A6K-80-R	HST-80
37	90 A	KTS-R-90	JKS-90	JJS-90	5014006-100	KLS-R-090	A6K-90-R	HST-90
45	100 A	KTS-R-100	JKS-100	JJS-100	5014006-100	KLS-R-100	A6K-100-R	HST-100
55	125 A	KTS-R-125	JKS-125	JJS-125	2028220-125	KLS-150	A6K-125-R	HST-125
75	150 A	KTS-R-150	JKS-150	JJS-150	2028220-150	KLS-175	A6K-150-R	HST-150

* UL compliance only 525-600 V

Table 10.13 525-690V*, Frame Sizes B and C

10.4 Connection Tightening Torques

Enclosure	Power (kW)				Torque (Nm)					
	200-240V	380-480/500V	525-600V	525-690V	Mains	Motor	DC connection	Brake	Earth	Relay
A2	0.25 - 2.2	0.37 - 4.0			1.8	1.8	1.8	1.8	3	0.6
A3	3.0 - 3.7	5.5 - 7.5	0.75 - 7.5		1.8	1.8	1.8	1.8	3	0.6
A4	0.25 - 2.2	0.37 - 4.0			1.8	1.8	1.8	1.8	3	0.6
A5	0.25 - 3.7	0.37 - 7.5	0.75 - 7.5		1.8	1.8	1.8	1.8	3	0.6
B1	5.5 - 7.5	11 - 15	11 - 15		1.8	1.8	1.5	1.5	3	0.6
B2	11	18	18	11	4.5	4.5	3.7	3.7	3	0.6
		22	22	22	4.5	4.5	3.7	3.7	3	0.6
B3	5.5 - 7.5	11 - 15	11 - 15		1.8	1.8	1.8	1.8	3	0.6
B4	11 - 15	18 - 30	18 - 30		4.5	4.5	4.5	4.5	3	0.6
C1	15 - 22	30 - 45	30 - 45		10	10	10	10	3	0.6
C2	30 - 37	55 - 75	55 - 75	30 - 75	14/24 ¹⁾	14/24 ¹⁾	14	14	3	0.6
C3	18 - 22	37 - 45	37 - 45		10	10	10	10	3	0.6
C4	30 - 37	55 - 75	55 - 75		14/24 ¹⁾	14/24 ¹⁾	14	14	3	0.6

Table 10.14 Tightening of Terminals

¹⁾ For different cable dimensions x/y, where $x \leq 95\text{mm}^2$ and $y \geq 95\text{mm}^2$.

Index

A		Cooling	
A53	17	Cooling.....	8
A54	17	Clearance.....	22
AC		Copying Parameter Settings	29
Input.....	6, 14	Current	
Mains.....	6, 10, 14	Limit.....	25, 52
Waveform.....	6	Rating.....	8, 52
Alarm Log	30, 28	D	
Alarms	48	Danfoss FC	20
AMA		DC	
With T27 Connected.....	40	Current.....	6, 46
Without T27 Connected.....	40	Link.....	51
Analog		Derating	52, 8
Inputs.....	15, 51, 71	Digital	
Output.....	15, 72	Input.....	47, 52, 17
Application Examples	40	Inputs.....	15, 47, 32
Approvals	1	Inputs.....	70
Auto		Output.....	72
Mode.....	28	Disconnect	
On.....	29, 45, 47	Switch.....	23
Automatic Motor Adaptation	24, 45	Switches.....	21
Auto-reset	27	E	
B		Electrical Noise	13
Back Plate	9	EMC	22, 53
Braking	53, 45	Encoder Rotation	25
Branch Circuit Protection	75	External	
C		Commands.....	6, 45
Cable Lengths And Cross Sections	73	Controllers.....	6
Circuit Breakers	22	Interlock.....	17, 33
Clearance		Voltage.....	31
Clearance.....	54, 8	F	
Requirements.....	8	Fault	
Closed Loop	17	Log.....	28, 30
Communication Option	54	Messages.....	51
Conduit	12, 22	Feedback	17, 22, 54, 46, 57
Control		Floating Delta	14
Cables.....	16	Full Load Current	8, 21
Card Performance.....	73	Functional Testing	5, 26, 21
Card, +10V DC Output.....	72	Fuses	22, 54, 59, 75
Card, 24 V DC Output.....	72	Fusing	12, 22
Card, RS-485 Serial Communication.....	72	G	
Card, USB Serial Communication.....	72	Ground	
Characteristics.....	73	Connections.....	12, 22
Signal.....	31, 32, 45	Loops.....	16
System.....	5, 6	Wire.....	12, 13, 22
Terminals.....	10, 24, 29, 45, 47, 32, 16	Grounded Delta	14
Wire.....	16	Grounding	
Wiring.....	12, 16, 22, 14	Grounding.....	12, 13, 14, 21, 22
		Using Shielded Cable.....	13

Index	VLT® Automation Drive Operating Instructions
H	
Hand On.....	25, 29, 45
Harmonics.....	6
I	
IEC 61800-3.....	14
Induced Voltage.....	12
Initialisation.....	30
Input	
Current.....	14
Disconnect.....	14
Power.....	12, 14, 22, 48, 59, 6, 21
Signal.....	31
Signals.....	16, 17
Terminals.....	10, 14, 17, 21, 51
Voltage.....	23, 48, 52
Installation.....	5, 8, 9, 12, 16, 20, 22, 53, 23
Isolated Mains.....	14
L	
Leakage	
Current.....	21, 12
Current (>3,5mA).....	13
Lifting.....	9
Local	
Control.....	27, 29, 45
Control Panel.....	27
Mode.....	25
Operation.....	27
Start.....	25
Local-control Test.....	25
M	
Main Menu.....	28, 31, 28
Mains	
Mains.....	12
Supply.....	61, 65, 66, 67
Supply (L1, L2, L3).....	70
Voltage.....	28, 29, 45, 51, 55
Manual Initialisation.....	30
Mechanical Brake Control.....	20
Menu	
Keys.....	27, 28
Structure.....	29, 34
Modbus RTU.....	20
Motor	
Cables.....	8, 12, 13
Current.....	6, 24, 52, 55, 28
Data.....	24, 25, 30, 53, 52, 55, 24
Leads.....	53
Output.....	70
Power.....	10, 12, 55
Protection.....	12, 74
Rotation.....	25, 28
Speeds.....	23
Status.....	6
Wiring.....	12, 13
Wiring, And.....	22
Mounting.....	9, 22
Multiple	
Frequency Converters.....	12, 13
Motors.....	21
N	
Navigation Keys.....	23, 31, 45, 27, 29
Noise Isolation.....	12, 22
O	
Open Loop	
.....	17, 31
Operation Keys	
.....	29
Optional Equipment	
.....	14, 17, 23, 6
Output	
Current.....	46, 52
Performance (U, V, W).....	70
Signal.....	34
Terminals.....	10, 21
Overcurrent.....	46
Overload Protection.....	8, 12
Overvoltage.....	26, 46
P	
PELV.....	14, 43
Power	
Connections.....	12
Factor.....	6, 13, 22
Power-dependent.....	61
Pre-start.....	21
Programming	
Programming.....	5, 17, 26, 28, 30, 33, 34, 39, 51, 23, 27, 29, 31
Example.....	31
Protection And Features.....	74
Pulse/Encoder Inputs.....	71
Q	
Quick	
Menu.....	31, 33, 28
Set-up.....	24

Index	VLT® Automation Drive Operating Instructions
R	
Ramp-down Time.....	25
Ramp-up Time.....	25
RCD.....	13
Reference.....	1, 40, 45, 46, 28
Relay Outputs.....	15, 73
Remote	
Commands.....	6
Programming.....	39
Reference.....	46
Reset.....	27, 30, 47, 48, 52, 54, 57, 29
RFI Filter.....	14
RMS Current.....	6
Run	
Command.....	26
Permissive.....	46
S	
Safety Inspection.....	21
Screened Control Cables.....	16
Serial Communication... 6, 10, 15, 16, 29, 30, 45, 46, 47, 53, 48, 20,	72
Set Up.....	28
Setpoint.....	47
Set-up.....	26, 28
Shielded	
Cable.....	8, 12, 22
Wire.....	12
Specifications.....	5, 9, 20, 61
Speed Reference.....	17, 26, 32, 45, 40
Start Up.....	5, 30, 31, 21, 22, 59
Status	
Messages.....	45
Mode.....	45
Stop Command.....	46
Supply Voltage.....	14, 15, 21, 51, 52, 54
Surroundings.....	73
Switching Frequency.....	46, 52
Symbols.....	1
System	
Feedback.....	6
Monitoring.....	48
Start Up.....	26
T	
Technical Data.....	70
Temperature Limits.....	22
Terminal	
53.....	31, 17, 31
54.....	17
Programming.....	17
Programming Examples.....	32
Thermistor	
Thermistor.....	14, 52, 43
Control Wiring.....	14
Tightening Of Terminals.....	83
Torque	
Characteristics.....	70
Limit.....	25
Transient Protection.....	6
Trip	
Trip.....	48
Function.....	12
Trip-lock.....	48
Troubleshooting.....	5, 51, 59
V	
Voltage Level.....	70
W	
Warning	
And Alarm Definitions.....	49
And Alarm Displays.....	48
And Alarm Types.....	48
Warnings.....	48
Wire Sizes.....	12, 13



www.danfoss.com/drives

Danfoss can accept no responsibility for possible errors in catalogues, brochures and other printed material. Danfoss reserves the right to alter its products without notice. This also applies to products already on order provided that such alterations can be made without subsequential changes being necessary in specifications already agreed. All trademarks in this material are property of the respective companies. Danfoss and the Danfoss logotype are trademarks of Danfoss A/S. All rights reserved.



