



Instruction Manual

VLT® AutomationDrive FC 300

Safety

⚠ WARNING

HIGH VOLTAGE!

Adjustable frequency drives contain high voltage when connected to AC line power. Installation, start-up, and maintenance should be performed by qualified personnel only. Failure to perform installation, start-up, and maintenance by qualified personnel could result in death or serious injury.

High Voltage

Adjustable frequency drives are connected to hazardous AC line voltage. Extreme care should be taken to protect against shock. Only trained personnel familiar with electronic equipment should install, start, or maintain this equipment.

⚠ WARNING

UNINTENDED START!

When the adjustable frequency drive is connected to AC line power, the motor may start at any time. The adjustable frequency drive, motor, and any driven equipment must be in operational readiness. Failure to be in operational readiness when the adjustable frequency drive is connected to AC line power could result in death, serious injury, equipment, or property damage.

Unintended Start

When the adjustable frequency drive is connected to the AC line power, the motor may be started by means of an external switch, a serial bus command, an input reference signal, or a cleared fault condition. Use appropriate cautions to guard against an unintended start.

⚠ WARNING

DISCHARGE TIME!

Adjustable frequency drives contain DC link capacitors that can remain charged even when AC line power is disconnected. To avoid electrical hazards, remove AC line power from the adjustable frequency drive before doing any service or repair and wait the amount of time specified in *Table 1.1*. Failure to wait the specified time after power has been removed prior to doing service or repair on the unit could result in death or serious injury.

Voltage (V)	Minimum waiting time (minutes)	
	4	15
200–240	0.34–5 hp [0.25–3.7 kW]	7.5–50 hp [5.5–37 kW]
380–480	0.34–10 hp [0.25–7.5 kW]	15–100 hp [11–75 kW]
525–600	1–10 hp [0.75–7.5 kW]	15–100 hp [11–75 kW]
525–690	n/a	15–100 hp [11–75 kW]

High voltage may be present even when the warning LEDs are off!

Discharge Time

Symbols

The following symbols are used in this manual.

⚠ WARNING

Indicates a potentially hazardous situation which, if not avoided, could result in death or serious injury.

⚠ CAUTION

Indicates a potentially hazardous situation which, if not avoided, may result in minor or moderate injury. It may also be used to alert against unsafe practices.

CAUTION

Indicates a situation that may result in equipment or property damage-only accidents.

NOTE!

Indicates highlighted information that should be observed in order to avoid mistakes or operate equipment at less than optimal performance.

Approvals



Contents

1 Introduction	2-1
1.1 Purpose of the Manual	2-2
1.2 Additional Resources	2-2
1.3 Product Overview	2-3
1.4 Internal Adjustable Frequency Drive Controller Functions	2-3
1.5 Frame Sizes and Power Ratings	2-5
2 Installation	3-1
2.1 Installation Site Checklist	3-1
2.2 Adjustable Frequency Drive and Motor Pre-installation Checklist	3-1
2.3 Mechanical Installation	3-1
2.3.1 Cooling	3-1
2.3.2 Lifting	3-2
2.3.3 Mounting	3-2
2.3.4 Tightening Torques	3-2
2.4 Electrical Installation	3-3
2.4.1 Requirements	3-5
2.4.2 Grounding Requirements	3-5
2.4.2.1 Leakage Current (>3.5mA)	3-6
2.4.2.2 Grounding Using Shielded Cable	3-6
2.4.3 Motor Connection	3-6
2.4.4 AC Line Power Connection	3-7
2.4.5 Control Wiring	3-7
2.4.5.1 Access	3-7
2.4.5.2 Control Terminal Types	3-8
2.4.5.3 Wiring to Control Terminals	3-9
2.4.5.4 Using Shielded Control Cables	3-9
2.4.5.5 Control Terminal Functions	3-10
2.4.5.6 Jumper Terminals 12 and 27	3-10
2.4.5.7 Terminal 53 and 54 Switches	3-10
2.4.5.8 Terminal 37	3-11
2.4.5.9 Mechanical Brake Control	3-14
2.4.6 Serial Communication	3-14
3 Start-up and Functional Testing	4-1
3.1 Pre-start	4-1
3.1.1 Safety Inspection	4-1
3.1.2 Start-up Check List	4-2

3.2 Applying Power to the Adjustable Frequency Drive	4-3
3.3 Basic Operational Programming	4-3
3.4 Automatic Motor Adaptation	4-4
3.5 Check Motor Rotation	4-5
3.6 Check Encoder Rotation	4-5
3.7 Local Control Test	4-5
3.8 System Start-up	4-6
4 User Interface	5-1
4.1 Local Control Panel	5-1
4.1.1 LCP Layout	5-1
4.1.2 Setting LCP Display Values	5-2
4.1.3 Display Menu Keys	5-2
4.1.4 Navigation Keys	5-3
4.1.5 Operation Keys	5-3
4.2 Backup and Copying Parameter Settings	5-3
4.2.1 Uploading Data to the LCP	5-4
4.2.2 Downloading Data from the LCP	5-4
4.3 Restoring Default Settings	5-4
4.3.1 Recommended Initialization	5-4
4.3.2 Manual Initialization	5-4
5 About Adjustable Frequency Drive Programming	6-1
5.1 Introduction	6-1
5.2 Programming Example	6-1
5.3 Control Terminal Programming Examples	6-2
5.4 International/North American Default Parameter Settings	6-3
5.5 Parameter Menu Structure	6-4
5.5.1 Main Menu Structure	6-5
5.6 Remote Programming with MCT 10 Set-up Software	6-9
6 Application Set-Up Examples	7-1
6.1 Introduction	7-1
6.2 Application Examples	7-1
7 Status Messages	8-1
7.1 Status Display	8-1
7.2 Status Message Definitions Table	8-1
8 Warnings and Alarms	9-1

8.1 System Monitoring	9-1
8.2 Warning and Alarm Types	9-1
8.3 Warning and Alarm Displays	9-1
8.4 Warning and Alarm Definitions	9-2
8.4.1 Fault Messages	9-4
9 Basic Troubleshooting	10-1
9.1 Start Up and Operation	10-1
10 Specifications	11-1
10.1 Power-dependent Specifications	11-1
10.2 General Technical Data	11-11
10.3 Fuse Tables	11-16
10.3.2 CE Compliance	11-17
10.4 Connection Tightening Torques	11-25
12 Index	12-1

1 Introduction

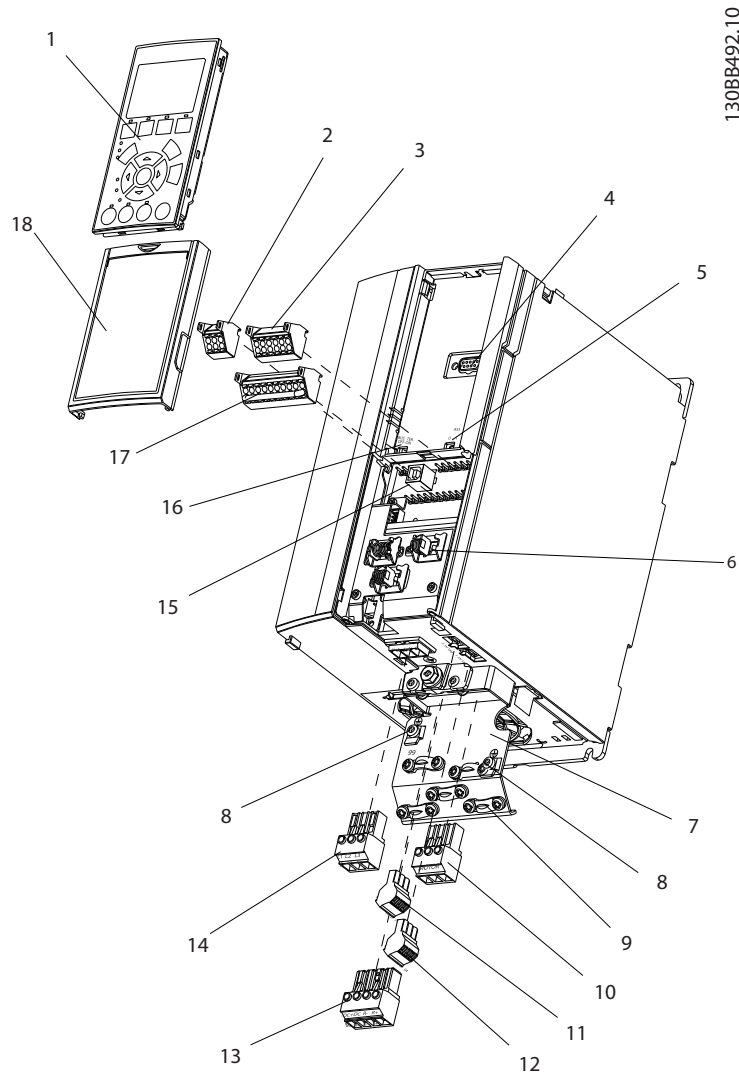
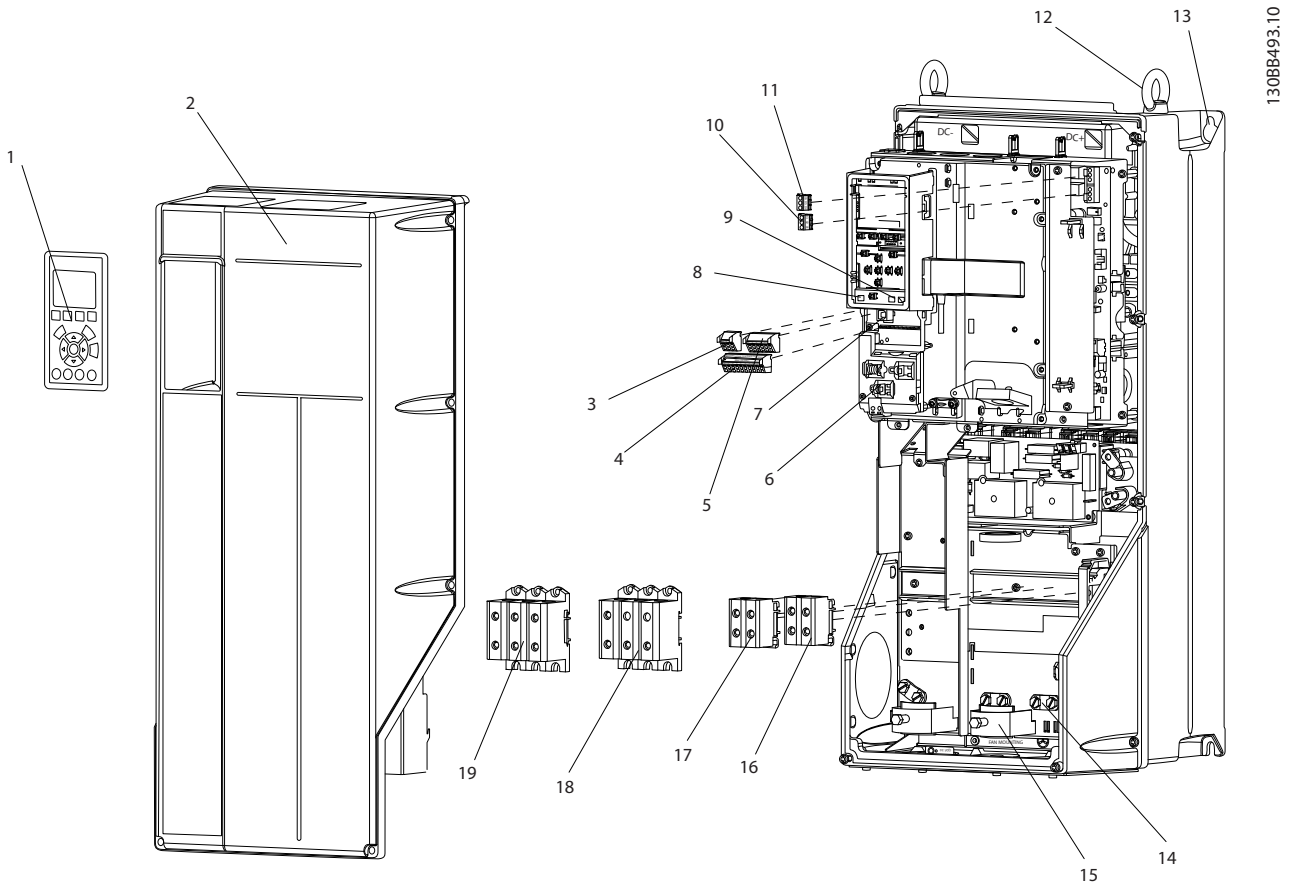

Figure 1.1 Exploded View A1-A3, IP20

1	LCP	10	Motor output terminals 96 (U), 97 (V), 98 (W)
2	RS-485 serial bus connector (+68, -69)	11	Relay 1 (01, 02, 03)
3	Analog I/O connector	12	Relay 2 (04, 05, 06)
4	LCP input plug	13	Brake (-81, +82) and load sharing (-88, +89) terminals
5	Analog switches (A53), (A54)	14	Line power input terminals 91 (L1), 92 (L2), 93 (L3)
6	Cable strain relief / PE ground	15	USB connector
7	Decoupling plate	16	Serial bus terminal switch
8	Grounding clamp (PE)	17	Digital I/O and 24 V power supply
9	Shielded cable grounding clamp and strain relief	18	Control cable coverplate



130BB493.10

Figure 1.2 Exploded View B and C Sizes, IP55/66

1	LCP	11	Relay 2 (04, 05, 06)
2	Cover	12	Lifting ring
3	RS-485 serial bus connector	13	Mounting slot
4	Digital I/O and 24 V power supply	14	Grounding clamp (PE)
5	Analog I/O connector	15	Cable strain relief / PE ground
6	Cable strain relief / PE ground	16	Brake terminal (-81, +82)
7	USB connector	17	Load sharing terminal (DC bus) (-88, +89)
8	Serial bus terminal switch	18	Motor output terminals 96 (U), 97 (V), 98 (W)
9	Analog switches (A53), (A54)	19	Line power input terminals 91 (L1), 92 (L2), 93 (L3)
10	Relay 1 (01, 02, 03)		

1.1 Purpose of the Manual

This manual is intended to provide detailed information for the installation and start-up of the adjustable frequency drive. Chapter 2 *Installation* provides requirements for mechanical and electrical installation, including input, motor, control and serial communications wiring, and control terminal functions. Chapter 3 *Start-up and Functional Testing* provides detailed procedures for start-up, basic operational programming, and functional testing.

The remaining chapters provide supplementary details. These include user interface, detailed programming, application examples, start-up troubleshooting, and specifications.

1.2 Additional Resources

Other resources are available to understand advanced Adjustable frequency drive functions and programming.

- The Programming Guide provides greater detail in how to work with parameters and many application examples.
- The Design Guide is intended to provide detailed capabilities and functionality to design motor control systems.
- Supplemental publications and manuals are available from Danfoss. See <http://www.danfoss.com/Products/Literature/Technical+Documentation.htm> for listings.
- Optional equipment is available that may change some of the procedures described. Be sure to see the instructions supplied with those options for specific requirements.

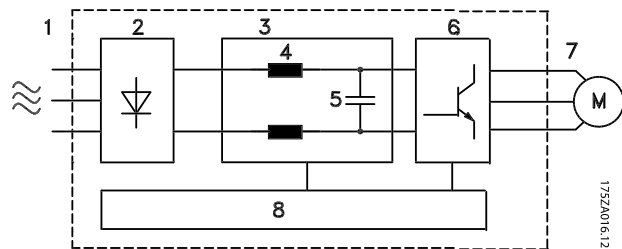

Figure 1.3 Adjustable Frequency Drive Block Diagram

Contact the local Danfoss supplier or go to <http://www.danfoss.com/Products/Literature/Technical+Documentation.htm> for downloads or additional information.

1.3 Product Overview

An adjustable frequency drive is an electronic motor controller that converts AC line power input into a variable AC waveform output. The frequency and voltage of the output are regulated to control the motor speed or torque. The adjustable frequency drive can vary the speed of the motor in response to system feedback, such as position sensors on a conveyor belt. The adjustable frequency drive can also regulate the motor by responding to remote commands from external controllers.

In addition, the adjustable frequency drive monitors the system and motor status, issues warnings or alarms for fault conditions, starts and stops the motor, optimizes energy efficiency, and offers many more control, monitoring, and efficiency functions. Operation and monitoring functions are available as status indications to an outside control system or serial communication network.

1.4 Internal Adjustable Frequency Drive Controller Functions

Below is a block diagram of the adjustable frequency drive's internal components. See *Table 1.1* for their functions.

Area	Title	Functions
1	Line power input	<ul style="list-style-type: none"> • Three-phase AC line power supply to the Adjustable frequency drive
2	Rectifier	<ul style="list-style-type: none"> • The rectifier bridge converts the AC input to DC current to supply inverter power
3	DC bus	<ul style="list-style-type: none"> • The adjustable frequency drive's intermediate DC bus circuit handles the DC current
4	DC reactors	<ul style="list-style-type: none"> • Filter the intermediate DC circuit voltage • Provide line transient protection • Reduce RMS current • Raise the power factor reflected back to the line • Reduce harmonics on the AC input
5	Capacitor bank	<ul style="list-style-type: none"> • Stores the DC power • Provides ride-through protection for short power losses
6	Inverter	<ul style="list-style-type: none"> • Converts the DC into a controlled PWM AC waveform for a controlled variable output to the motor
7	Output to motor	<ul style="list-style-type: none"> • Regulated three-phase output power to the motor
8	Control circuitry	<ul style="list-style-type: none"> • Input power, internal processing, output, and motor current are monitored to provide efficient operation and control • User interface and external commands are monitored and performed • Status output and control can be provided

Table 1.1 Adjustable Frequency Drive Internal Components

1.5 Frame Sizes and Power Ratings

Volts	Frame size hp (kW)												
	A1	A2	A3	A4	A5	B1	B2	B3	B4	C1	C2	C3	C4
200-240	0.34-2 [0.25-1.5]	0.34-3 [0.25-2.2]	4-5 [3.0-3.7]	0.34-3 [0.25-2.2]	0.34-5 [0.25-3.7]	7.5-10 [5.5-7.5]	15 [11]	7.5-10 [5.5-7.5]	15-20 [11-15]	20-30 [15-22]	40-50 [30-37]	25-30 [18.5-22]	40-50 [30-37]
380-480	0.5-2 [0.37-1.5]	5 [0.37-4.0]	7.5-10 [5.5-7.5]	5 [0.37-4.0]	5-10 [0.37-7.5]	15-20 [11-15]	25-30 [18.5-22]	15-20 [11-15]	25-40 [18.5-30]	40-60 [30-45]	75-100 [55-75]	50-60 [37-45]	75-100 [55-75]
525-600	N/A	N/A	1-10 [0.75-7.5]	N/A	1-10 [0.75-7.5]	15-20 [11-15]	25-30 [18.5-22]	15-20 [11-15]	25-40 [18.5-30]	40-60 [30-45]	75-120 [55-90]	50-60 [37-45]	75-120 [55-90]
525-690	N/A	N/A	N/A	N/A	N/A	N/A	15-30 [11-22]	N/A	N/A	N/A	40-100 [30-75]	N/A	N/A

Table 1.2 Frames Sizes and Power Ratings

2 Installation

2.1 Installation Site Checklist

- The Adjustable frequency drive relies on the ambient air for cooling. Observe the limitations on ambient air temperature for optimal operation
- Ensure that the installation location has sufficient support strength to mount the Adjustable frequency drive
- Keep the Adjustable frequency drive interior free from dust and dirt. Ensure that the components stay as clean as possible. In construction areas, provide a protective covering. Optional IP55 (NEMA 12) or IP66 (NEMA 4) enclosures may be necessary.
- Keep the manual, drawings, and diagrams accessible for detailed installation and operation instructions. It is important that the manual is available for equipment operators.
- Place equipment as near to the motor as possible. Keep motor cables as short as possible. Check the motor characteristics for actual tolerances. Do not exceed
 - 1000 ft [300 m] for unshielded motor leads
 - 500 ft [150 m] for shielded cable.

2.2 Adjustable Frequency Drive and Motor Pre-installation Checklist

- Compare the model number of unit on the nameplate to what was ordered to verify the proper equipment
- Ensure each of the following are rated for the same voltage:
 - Line power
 - Adjustable frequency drive
 - Motor
- Ensure that Adjustable frequency drive output current rating is equal to or greater than motor full load current for peak motor performance.

Motor size and Adjustable frequency drive power must match for proper overload protection.

If Adjustable frequency drive rating is less than motor, full motor output cannot be achieved.

2.3 Mechanical Installation

2.3.1 Cooling

- To provide cooling airflow, mount the unit to a solid flat surface or to the optional backplate (see 2.3.3 Mounting)
- Top and bottom clearance for air cooling must be provided. Generally, 4–10 in [100–225 mm] is required. See Figure 2.1 for clearance requirements
- Improper mounting can result in overheating and reduced performance.
- Derating for temperatures starting between 104°F [40°C] and 122°F [50°C] and elevation 3300 ft [1000 m] above sea level must be considered. See the equipment Design Guide for detailed information.

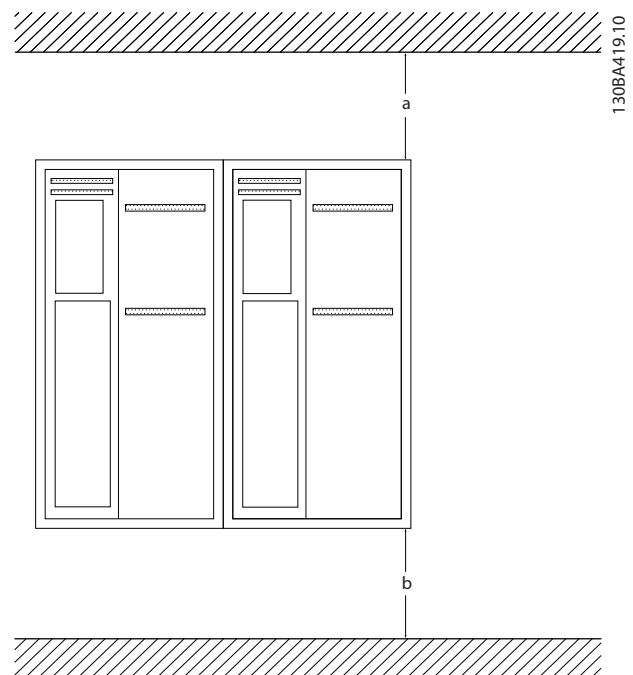

Figure 2.1 Top and Bottom Cooling Clearance

Enclosure	A1-A5	B1-B4	C1, C3	C2, C4
a/b (in [mm])	3.94 [100]	7.87 [200]	7.87 [200]	8.86 [225]

Table 2.1 Minimum Airflow Clearance Requirements

2.3.2 Lifting

- Check the weight of the unit to determine a safe lifting method
- Ensure that the lifting device is suitable for the task
- If necessary, plan for a hoist, crane, or forklift with the appropriate rating to move the unit
- For lifting, use hoist rings on the unit, when provided

2.3.3 Mounting

- Mount the unit vertically
- The Adjustable frequency drive allows side by side installation.
- Ensure that the strength of the mounting location will support the unit weight.
- Mount the unit to a solid flat surface or to the optional backplate to provide cooling airflow (see *Figure 2.2* and *Figure 2.3*).
- Improper mounting can result in overheating and reduced performance.
- Use the slotted mounting holes on the unit for wall mounting, when provided.

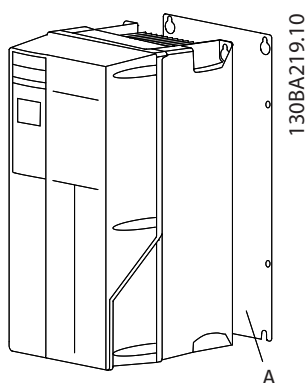

Figure 2.2 Proper Mounting with Backplate

Item A is a backplate properly installed for required airflow to cool the unit.

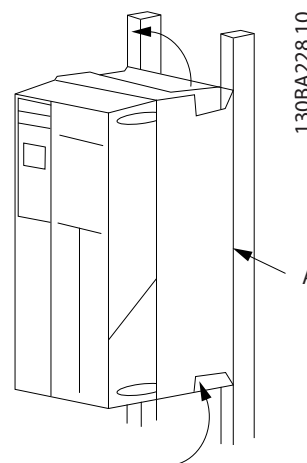

Figure 2.3 Proper Mounting with Railings

NOTE!

Backplate is needed when mounted on railings.

2.3.4 Tightening Torques

See *10.4.1 Connection Tightening Torques* for proper tightening specifications.

2.4 Electrical Installation

This section contains detailed instructions for wiring the Adjustable frequency drive. The following tasks are described.

- Wiring the motor to the Adjustable frequency drive output terminals
- Wiring the AC line power to the Adjustable frequency drive input terminals
- Connecting control and serial communication wiring
- After power has been applied, checking input and motor power; programming control terminals for their intended functions

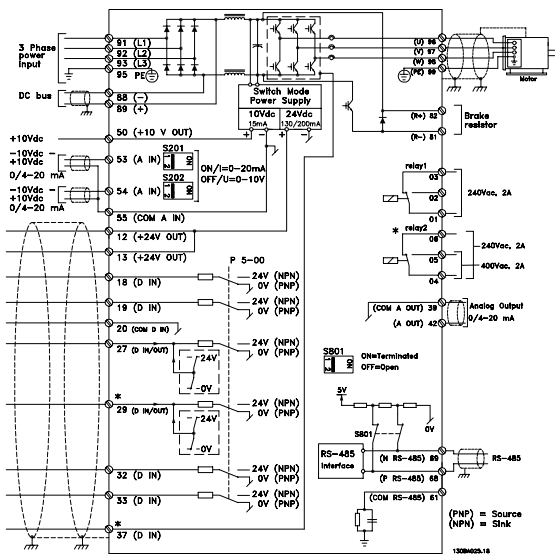

Figure 2.4 Basic Wiring Schematic Drawing.

A=Analog, D=Digital

Terminal 37 is used for Safe Stop. For Safe Stop installation instructions, refer to the Design Guide.

* Terminal 37 is not included in AutomationDrive FC 301 (except frame size A1). Relay 2 and terminal 29 have no function in AutomationDrive FC 301.

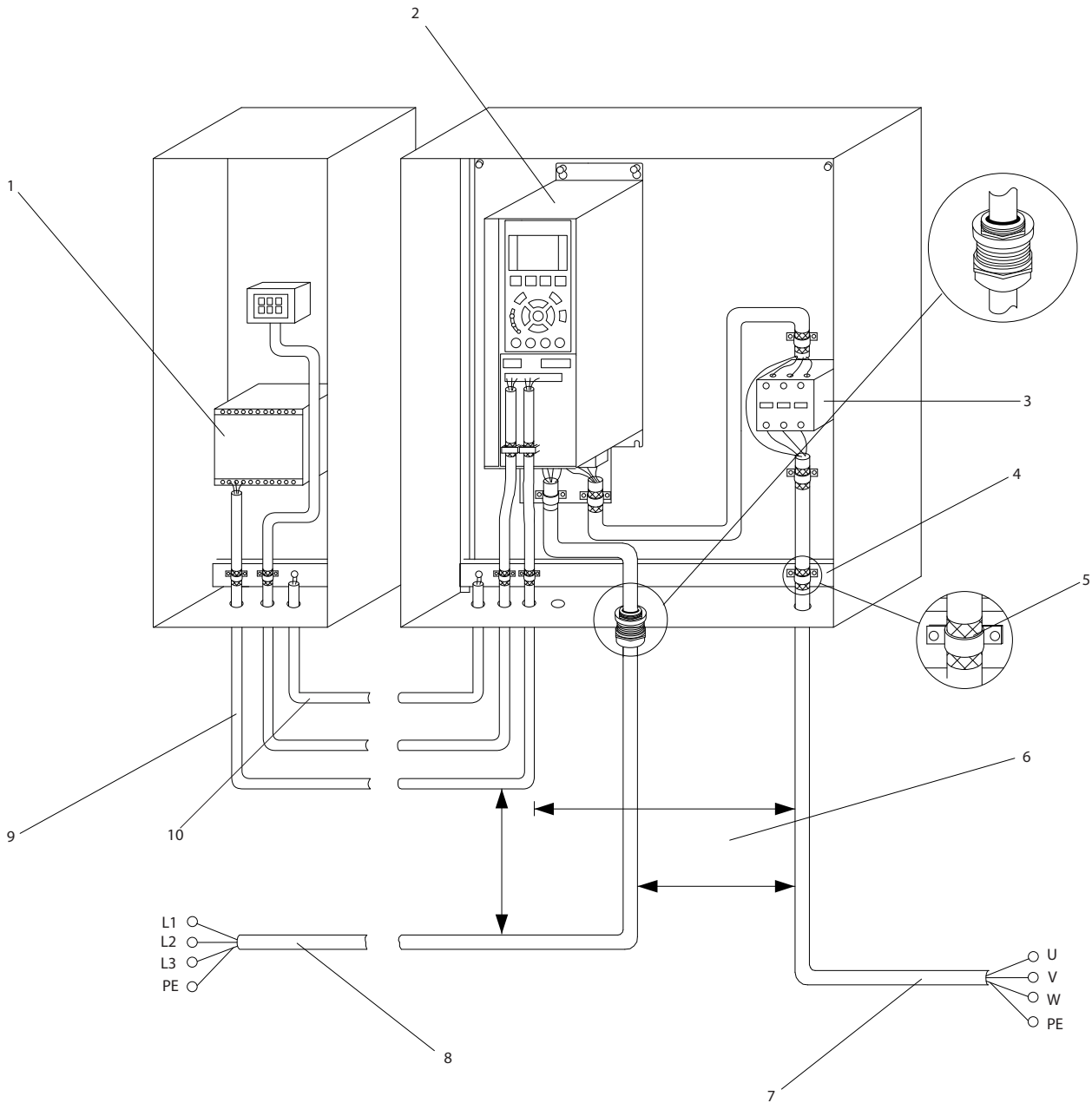

Figure 2.5 Typical Electrical Connection

1	PLC	6	Min. 7.9 in [200 mm] between control cables, motor and line power
2	Adjustable frequency drive	7	Motor, 3-phase and PE
3	Output contactor (Generally not recommended)	8	Line power, 3-phase and reinforced PE
4	Grounding rail (PE)	9	Control wiring
5	Cable insulation (stripped)	10	Equalizing min. 0.025 in ² [16mm ²]

2.4.1 Requirements

⚠ WARNING

EQUIPMENT HAZARD!

Rotating shafts and electrical equipment can be hazardous. All electrical work must conform to national and local electrical codes. It is strongly recommended that installation, start-up, and maintenance be performed only by trained and qualified personnel. Failure to follow these guidelines could result in death or serious injury.

CAUTION

WIRING ISOLATION!

Run input power, motor wiring and control wiring in three separate metallic conduits or use separated shielded cable for high frequency noise isolation. Failure to isolate power, motor and control wiring could result in less than optimum adjustable frequency drive and associated equipment performance.

For your safety, comply with the following requirements.

- Electronic controls equipment is connected to hazardous AC line voltage. Extreme care should be taken to protect against electrical hazards when applying power to the unit.
- Run motor cables from multiple adjustable frequency drives separately. Induced voltage from output motor cables run together can charge equipment capacitors even with the equipment turned off and locked out.

Overload and Equipment Protection

- An electronically activated function within the adjustable frequency drive provides overload protection for the motor. The overload calculates the level of increase to activate timing for the trip (controller output stop) function. The higher the current draw, the quicker the trip response. The overload provides Class 20 motor protection. See 8 *Warnings and Alarms* for details on the trip function.
- Because the motor wiring carries high frequency current, it is important that wiring for line power, motor power, and control is run separately. Use metallic conduit or separated shielded wire. Failure to isolate power, motor, and control wiring could result in less than optimum equipment performance.
- All adjustable frequency drives must be provided with short-circuit and overcurrent protection.

Input fusing is required to provide this protection, see *Figure 2.6*. If not factory supplied, fuses must be provided by the installer as part of installation. See maximum fuse ratings in *10.3 Fuse Tables*.

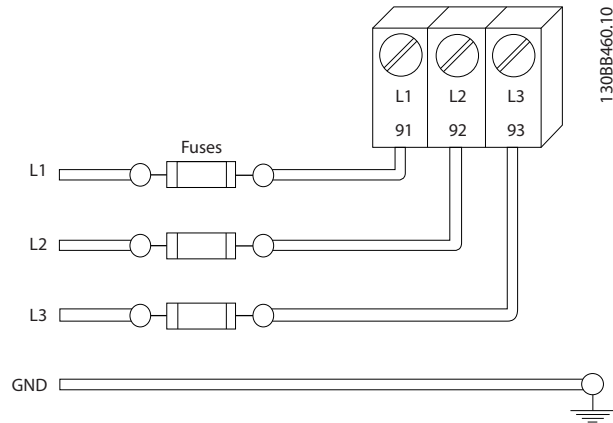

Figure 2.6 Adjustable Frequency Drive Fuses

Wire Type and Ratings

- All wiring must comply with local and national regulations regarding cross-section and ambient temperature requirements.
- Danfoss recommends that all power connections be made with a minimum 167°F [75°C] rated copper wire.
- See *10.1 Power-dependent Specifications* for recommended wire sizes.

2.4.2 Grounding Requirements

⚠ WARNING

GROUNDING HAZARD!

For operator safety, it is important to ground Adjustable frequency drive properly in accordance with national and local electrical codes as well as instructions contained within these instructions. Ground currents are higher than 3.5 mA. Failure to ground Adjustable frequency drive properly could result in death or serious injury.

NOTE!

It is the responsibility of the user or certified electrical installer to ensure correct grounding of the equipment in accordance with national and local electrical codes and standards.

- Follow all local and national electrical codes to ground electrical equipment properly.
- Proper protective grounding for equipment with ground currents higher than 3.5 mA must be established, see *Leakage Current (>3.5 mA)*
- A dedicated ground wire is required for input power, motor power and control wiring
- Use the clamps provided with on the equipment for proper ground connections
- Do not ground one Adjustable frequency drive to another in a “daisy chain” fashion
- Keep the ground wire connections as short as possible
- Use of high-strand wire to reduce electrical noise is recommended
- Follow the motor manufacturer wiring requirements

2.4.2.1 Leakage Current (>3.5mA)

Follow national and local codes regarding protective grounding of equipment with a leakage current > 3.5mA. Adjustable frequency drive technology implies high frequency switching at high power. This will generate a leakage current in the ground connection. A fault current in the Adjustable frequency drive at the output power terminals might contain a DC component which can charge the filter capacitors and cause a transient ground current. The ground leakage current depends on various system configurations including RFI filtering, shielded motor cables, and Adjustable frequency drive power.

EN/IEC61800-5-1 (Power Drive System Product Standard) requires special care if the leakage current exceeds 3.5mA. Grounding must be reinforced in one of the following ways:

- Ground wire of at least 0.0155 in² [10mm²]
- Two separate ground wires both complying with the dimensioning rules

See EN 60364-5-54 § 543.7 for further information.

Using RCDs

Where residual current devices (RCDs), also known as ground leakage circuit breakers (ELCBs), are used, comply with the following:

- Use RCDs of type B only which are capable of detecting AC and DC currents
- Use RCDs with an inrush delay to prevent faults due to transient ground currents
- Dimension RCDs according to the system configuration and environmental considerations

2.4.2.2 Grounding Using Shielded Cable

Grounding clamps are provided for motor wiring (see *Figure 2.7*).

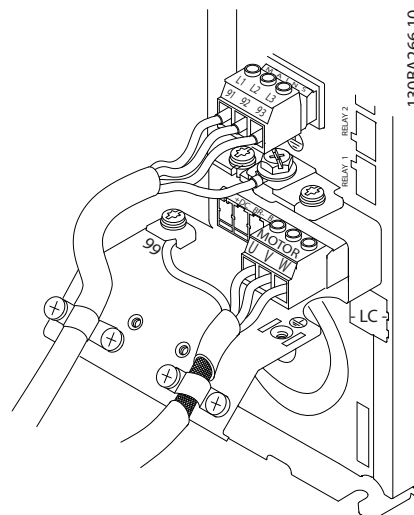

Figure 2.7 Grounding with Shielded Cable

2.4.3 Motor Connection

WARNING

INDUCED VOLTAGE!

Run output motor cables from multiple adjustable frequency drives separately. Induced voltage from output motor cables run together can charge equipment capacitors even with the equipment turned off and locked out. Failure to run output motor cables separately could result in death or serious injury.

- For maximum wire sizes, see *10.1 Power-dependent Specifications*
- Comply with local and national electrical codes for cable sizes.
- Motor wiring knockouts or access panels are provided at the base of IP21 and higher (NEMA1/12) units
- Do not install power factor correction capacitors between the adjustable frequency drive and the motor
- Do not wire a starting or pole-changing device between the adjustable frequency drive and the motor.
- Connect the 3-phase motor wiring to terminals 96 (U), 97 (V), and 98 (W).

- Ground the cable in accordance with grounding instructions provided.
- Torque terminals in accordance with the information provided in 10.4.1 Connection Tightening Torques
- Follow the motor manufacturer wiring requirements

Figure 2.8 represents line power input, motor, and ground grounding for basic adjustable frequency drives. Actual configurations vary with unit types and optional equipment.

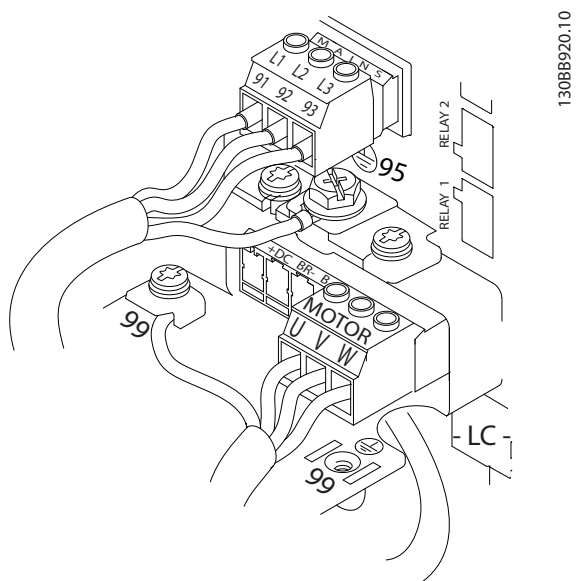

Figure 2.8 Example of Motor, Line Power and Ground Wiring

2.4.4 AC Line Power Connection

- Size wiring based upon the input current of the Adjustable frequency drive. For maximum wire sizes, see 10.1 Power-dependent Specifications.
- Comply with local and national electrical codes for cable sizes.
- Connect 3-phase AC input power wiring to terminals L1, L2, and L3 (see Figure 2.8).
- Depending on the configuration of the equipment, input power will be connected to the line power input terminals or the input disconnect.

- Ground the cable in accordance with grounding instructions provided in 2.4.2 Grounding Requirements
- All adjustable frequency drives may be used with an isolated input source as well as with ground reference power lines. When supplied from an isolated line power source (IT line power or floating delta) or TT/TN-S line power with a grounded leg (grounded delta), set 14-50 RFI 1 to OFF. When off, the internal RFI filter capacitors between the chassis and the intermediate circuit are isolated to avoid damage to the intermediate circuit and to reduce ground capacity currents in accordance with IEC 61800-3.

2.4.5 Control Wiring

- Isolate control wiring from high power components in the adjustable frequency drive.
- If the adjustable frequency drive is connected to a thermistor, for PELV isolation, optional thermistor control wiring must be reinforced/ double insulated. A 24 VDC supply voltage is recommended.

2.4.5.1 Access

- Remove access coverplate with a screwdriver. See Figure 2.9.
- Or remove front cover by loosening attaching screws. See Figure 2.10.

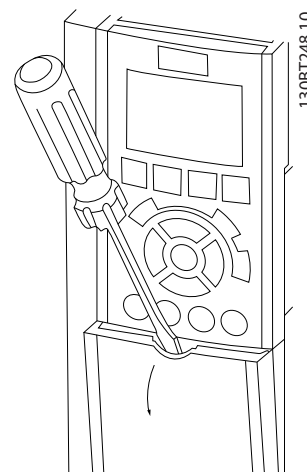

Figure 2.9 Control Wiring Access for A2, A3, B3, B4, C3 and C4 Enclosures

2

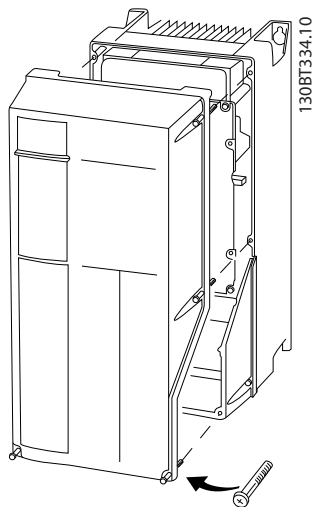

Figure 2.10 Control Wiring Access for A4, A5, B1, B2, C1 and C2 Enclosures

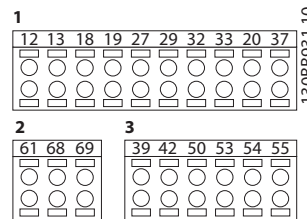

Figure 2.12 Terminal Numbers

- **Connector 1** provides four programmable digital inputs terminals, two additional digital terminals programmable as either input or output, a 24V DC terminal supply voltage, and a common for optional customer supplied 24V DC voltage. FC 302 and FC 301 (optional in A1 enclosure) also provide a digital input for STO (Safe Torque Off) function.
- **Connector 2** terminals (+)68 and (-)69 are for an RS-485 serial communications connection
- **Connector 3** provides two analog inputs, one analog output, 10V DC supply voltage, and commons for the inputs and output
- **Connector 4** is a USB port available for use with the MCT 10 Set-up Software
- Also provided are two Form C relay outputs that are in various locations depending upon the adjustable frequency drive configuration and size
- Some options available for ordering with the unit may provide additional terminals. See the manual provided with the equipment option.

Please see Table 2.2 before tightening the covers.

Frame	IP20	IP21	IP55	IP66
A4/A5	-	-	2	2
B1	-	*	2.2	2.2
B2	-	*	2.2	2.2
C1	-	*	2.2	2.2
C2	-	*	2.2	2.2

* No screws to tighten
14°F Does not exist

Table 2.2 Tightening Torques for Covers (Nm)

2.4.5.2 Control Terminal Types

Figure 2.11 and shows the removable adjustable frequency drive connectors. Terminal functions and default settings are summarized in Table 2.3.

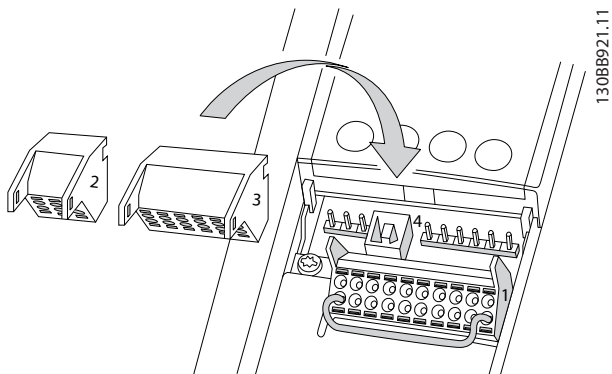

Figure 2.11 Control Terminal Locations

See 10.2 General Technical Data for terminal ratings details.

Terminal description			
Terminal	Parameter	Default setting	Description
Digital inputs/outputs			
12, 13	-	+24V DC	24V DC supply voltage. Maximum output current is 200mA total (130mA for FC 301) for all 24V loads. Useable for digital inputs and external transducers.
18	5-10	[8] Start	Digital inputs.
19	5-11	[10] Reversing	
32	5-14	[0] No operation	
33	5-15	[0] No operation	

Terminal description			
Terminal	Parameter	Default setting	Description
27	5-12	[2] Coast inverse	Selectable for either digital input or output. Default setting is input.
29	5-13	[14] JOG	
20	-		Common for digital inputs and 0V potential for 24V supply.
37	-	Safe Torque Off (STO)	Safe input. Used for STO.
Analog inputs/outputs			
39	-		Common for analog output
42	6-50	[0] No operation	Programmable analog output. The analog signal is 0–20mA or 4–20mA at a maximum of 500Ω
50	-	+10V DC	10V DC analog supply voltage. 15mA maximum commonly used for potentiometer or thermistor.
53	6-1	Reference	Analog input.
54	6-2	Feedback	Selectable for voltage or current. Switches A53 and A54 select mA or V.
55	-		Common for analog input

Terminal description			
Terminal	Parameter	Default setting	Description
Serial communication			
61	-		Integrated RC filter for cable screen. ONLY for connecting the shield when experiencing EMC problems.
68 (+)	8-3		RS-485 Interface. A control card switch is provided for termination resistance.
69 (-)	8-3		
Relays			

Terminal description			
Terminal	Parameter	Default setting	Description
01, 02, 03	5-40 [0]	[0] No operation	Form C relay output. Usable for AC or DC voltage and resistive or inductive loads.
04, 05, 06	5-40 [1]	[0] No operation	

Table 2.3 Terminal Description

2.4.5.3 Wiring to Control Terminals

Control terminal connectors can be unplugged from the Adjustable frequency drive for ease of installation, as shown in *Figure 2.11*.

1. Open the contact by inserting a small screwdriver into the slot above or below the contact, as shown in *Figure 2.13*.
2. Insert the bared control wire into the contact.
3. Remove the screwdriver to fasten the control wire into the contact.
4. Ensure the contact is firmly established and not loose. Loose control wiring can be the source of equipment faults or less than optimal operation.

See *10.1 Power-dependent Specifications* for control terminal wiring sizes.

See *6 Application Set-Up Examples* for typical control wiring connections.

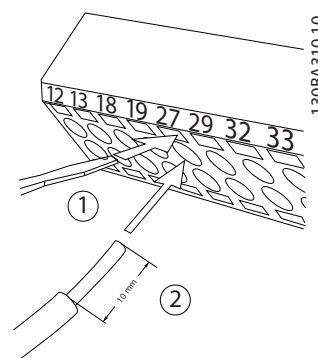

Figure 2.13 Connecting Control Wiring

2.4.5.4 Using Shielded Control Cables

Correct shielding

The preferred method in most cases is to secure control and serial communication cables with shielding clamps provided at both ends to ensure best possible high frequency cable contact.

If the ground potential between the adjustable frequency drive and the PLC is different, electric noise may occur that will disturb the entire system. Solve this problem by fitting

an equalizing cable next to the control cable. Minimum cable cross-section: 16 mm².

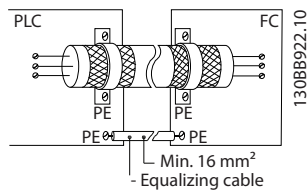

50/60Hz ground loops

With very long control cables, ground loops may occur. To eliminate ground loops, connect one end of the shield-to-ground with a 100nF capacitor (keeping leads short).

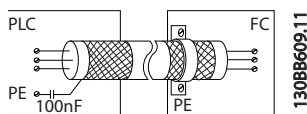

Avoid EMC noise on serial communication

This terminal is grounded via an internal RC link. Use twisted-pair cables to reduce interference between conductors. The recommended method is shown below:

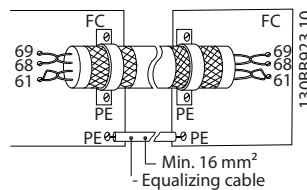

Alternatively, the connection to terminal 61 can be omitted:

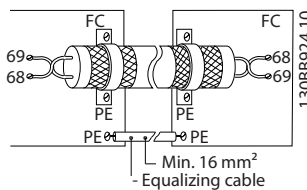

2.4.5.5 Control Terminal Functions

Adjustable frequency drive functions are commanded by receiving control input signals.

- Each terminal must be programmed for the function it will be supporting in the parameters associated with that terminal. See Table 2.3 for terminals and associated parameters.
- It is important to confirm that the control terminal is programmed for the correct function. See 4 User Interface for details on accessing parameters and 5 About Adjustable Frequency Drive Programming for details on programming.

- The default terminal programming is intended to initiate Adjustable frequency drive functioning in a typical operational mode.

2.4.5.6 Jumper Terminals 12 and 27

A jumper wire may be required between terminal 12 (or 13) and terminal 27 for the Adjustable frequency drive to operate when using factory default programming values.

- Digital input terminal 27 is designed to receive an 24V DC external interlock command. In many applications, the user wires an external interlock device to terminal 27.
- When no interlock device is used, wire a jumper between control terminal 12 (recommended) or 13 to terminal 27. This provides an internal 24V signal on terminal 27
- No signal present prevents the unit from operating.
- When the status line at the bottom of the LCP reads AUTO REMOTE COAST, this indicates that the unit is ready to operate but is missing an input signal on terminal 27.
- When factory installed optional equipment is wired to terminal 27, do not remove that wiring.

2.4.5.7 Terminal 53 and 54 Switches

- Analog input terminals 53 and 54 can select either voltage (-10–10V) or current (0/4–20mA) input signals
- Remove power to the Adjustable frequency drive before changing switch positions
- Set switches A53 and A54 to select the signal type. U selects voltage, I selects current.
- The switches are accessible when the LCP has been removed (see Figure 2.14). Note that some option cards available for the unit may cover these switches and must be removed to change switch settings. Always remove power to the unit before removing option cards.
- Terminal 53 default is for a speed reference signal in open-loop set in 16-61 Terminal 53 Switch Setting
- Terminal 54 default is for a feedback signal in closed-loop set in 16-63 Terminal 54 Switch Setting

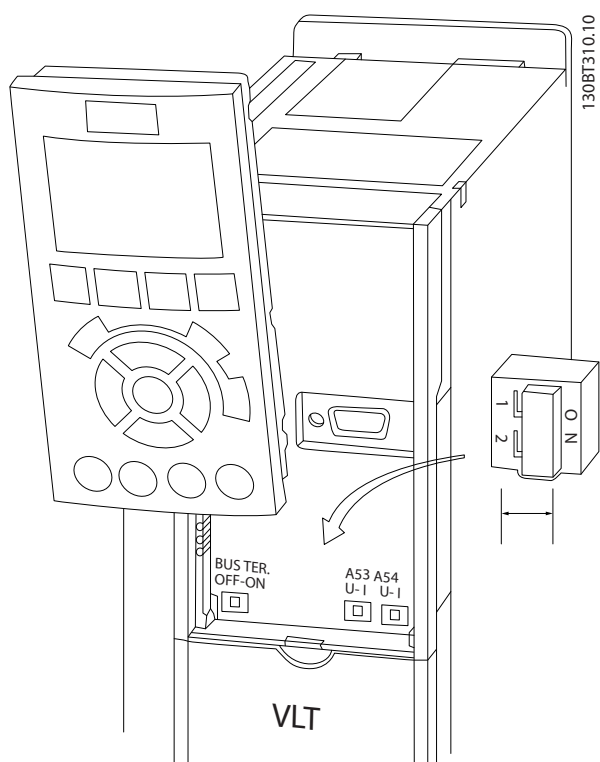

Figure 2.14 Location of Terminals 53 and 54 Switches and Bus Termination Switch

2.4.5.8 Terminal 37

Terminal 37 Safe Stop Function

The FC 302 and FC 301 (optional for A1 enclosure) is available with safe stop functionality via control terminal 37. Safe stop disables the control voltage of the power semiconductors of the Adjustable frequency drive output stage which in turn prevents generating the voltage required to rotate the motor. When the Safe Stop (T37) is activated, the Adjustable frequency drive issues an alarm, trips the unit, and coasts the motor to a stop. Manual restart is required. The safe stop function can be used for stopping the Adjustable frequency drive in emergency stop situations. In the normal operating mode when safe stop is not required, use the adjustable frequency drive's regular stop function instead. When automatic restart is used – the requirements according to ISO 12100-2 paragraph 5.3.2.5 must be fulfilled.

Liability Conditions

It is the responsibility of the user to ensure personnel installing and operating the Safe Stop function:

- Read and understand the safety regulations concerning health and safety/accident prevention.
- Understand the generic and safety guidelines given in this description and the extended description in the *Design Guide*.
- Have a good knowledge of the generic and safety standards applicable to the specific application.

User is defined as: integrator, operator, servicing, maintenance staff.

Standards

Use of safe stop on terminal 37 requires that the user satisfies all provisions for safety including relevant laws, regulations and guidelines. The optional safe stop function complies with the following standards.

- EN 954-1: 1996 Category 3
- IEC 60204-1: 2005 category 0 – uncontrolled stop
- IEC 61508: 1998 SIL2
- IEC 61800-5-2: 2007 – safe torque off (STO) function
- IEC 62061: 2005 SIL CL2
- ISO 13849-1: 2006 Category 3 PL d
- ISO 14118: 2000 (EN 1037) – prevention of unexpected start-up

The information and instructions of the instruction manual are not sufficient for a proper and safe use of the safe stop functionality. The related information and instructions of the relevant *Design Guide* must be followed.

Protective Measures

- Safety engineering systems may only be installed and commissioned by qualified and skilled personnel.
- The unit must be installed in an IP54 cabinet or in an equivalent environment.
- The cable between terminal 37 and the external safety device must be short circuit protected according to ISO 13849-2 table D.4
- If any external forces influence the motor axis (e.g., suspended loads), additional measures (e.g., a safety holding brake) are required in order to eliminate hazards.

Safe Stop Installation and Set-up

⚠ WARNING
SAFE STOP FUNCTION!

The safe stop function does NOT isolate AC line voltage to the Adjustable frequency drive or auxiliary circuits. Perform work on electrical parts of the Adjustable frequency drive or the motor only after isolating the AC line voltage supply and waiting the length of time specified under Safety in this manual. Failure to isolate the AC line voltage supply from the unit and waiting the time specified could result in death or serious injury.

- It is not recommended to stop the Adjustable frequency drive by using the Safe Torque Off function. If a running Adjustable frequency drive is stopped by using the function, the unit will trip and stop by coasting. If this is not acceptable, e.g., causes danger, the Adjustable frequency drive and machinery must be stopped using the appropriate stopping mode before using this function. Depending on the application, a mechanical brake may be required.
- Concerning synchronous and permanent magnet motor adjustable frequency drives in case of a multiple IGBT power semiconductor failure: In spite of the activation of the Safe torque off function, the Adjustable frequency drive system can produce an alignment torque which maximally rotates the motor shaft by $180/p$ degrees. p denotes the pole pair number.
- This function is suitable for performing mechanical work on the Adjustable frequency drive system or affected area of a machine only. It does not provide electrical safety. This function should not be used as a control for starting and/or stopping the Adjustable frequency drive.

The following requirements have to be met to perform a safe installation of the Adjustable frequency drive:

1. Remove the jumper wire between control terminals 37 and 12 or 13. Cutting or breaking the jumper is not sufficient to avoid short-circuiting. (See jumper on *Figure 2.15*.)
2. Connect an external Safety monitoring relay via a NO safety function (the instruction for the safety device must be followed) to terminal 37 (safe stop) and either terminal 12 or 13 (24V DC). The safety monitoring relay must comply with Category 3 (EN 954-1) / PL "d" (ISO 13849-1).

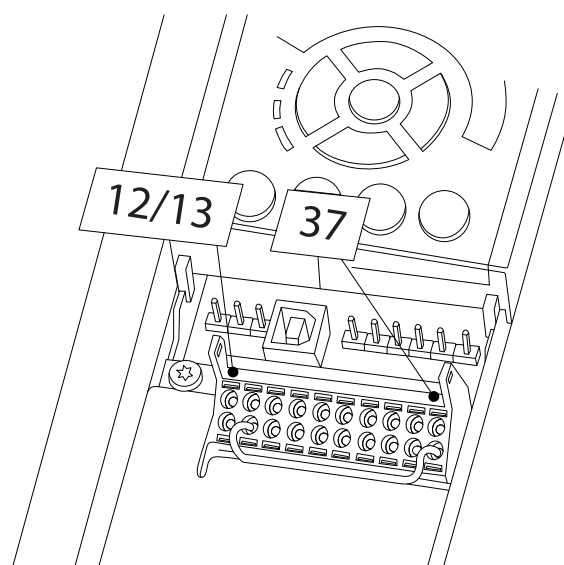

130BA874.10

Figure 2.15 Jumper between Terminal 12/13 (24V) and 37

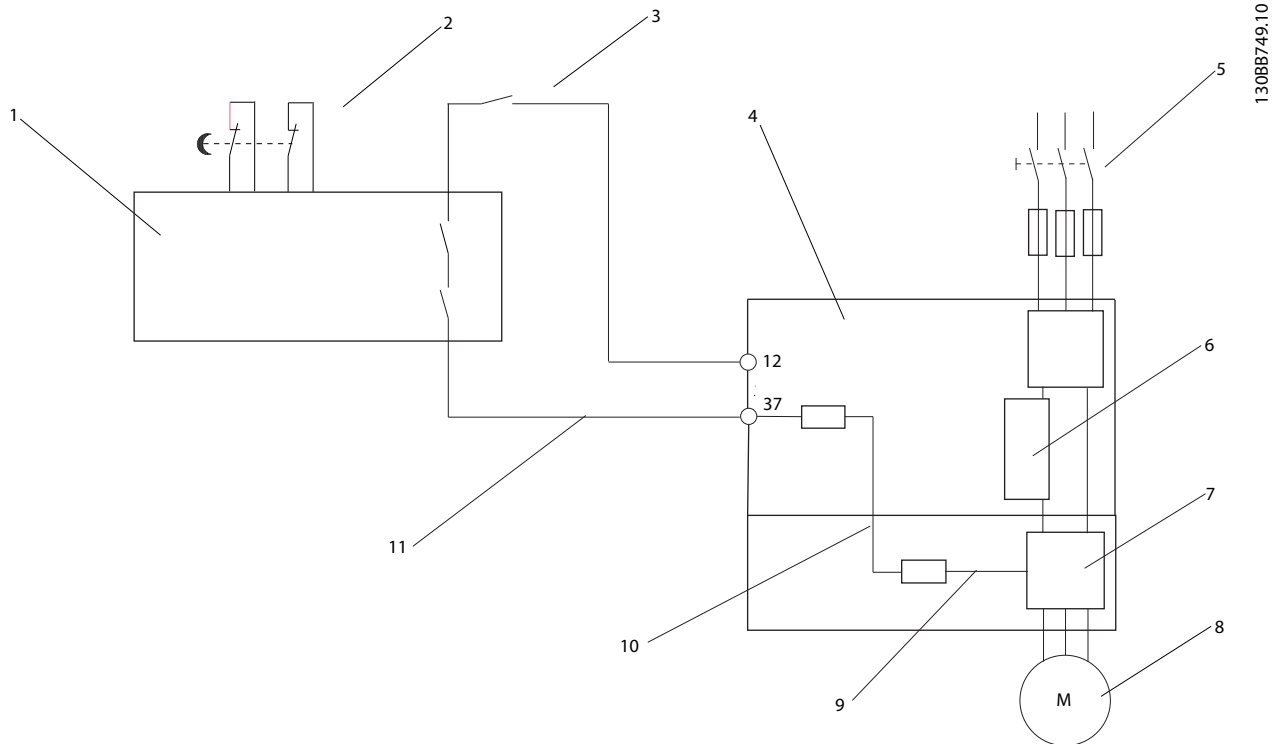

130BB749.10

2

Figure 2.16 Installation to Achieve a Stopping Category 0 (EN 60204-1) with Safety Cat. 3 (EN 954-1) / PL “d” (ISO 13849-1).

1	Safety device Cat. 3 (circuit interrupt device, possibly with release input)	7	Inverter
2	Door contact	8	Motor
3	Contactors (Coast)	9	5V DC
4	Adjustable frequency drive	10	Safe channel
5	Line power	11	Short-circuit protected cable (if not inside installation cabinet)
6	Control board		

Safe Stop Commissioning Test

After installation and before first operation, perform a commissioning test of the installation making use of safe stop. Moreover, perform the test after each modification of the installation.

2.4.5.9 Mechanical Brake Control

In hoisting/lowering applications, it is necessary to be able to control an electro-mechanical brake:

- Control the brake using any relay output or digital output (terminal 27 or 29).
- Keep the output closed (voltage-free) as long as the Adjustable frequency drive is unable to 'support' the motor, for example due to the load being too heavy.
- Select *Mechanical brake control* [32] in par. 5-4* for applications with an electro-mechanical brake.
- The brake is released when the motor current exceeds the preset value in 2-20 *Release Brake Current*.
- The brake is engaged when the output frequency is less than the frequency set in 2-21 *Activate Brake Speed [RPM]* or 2-22 *Activate Brake Speed [Hz]*, and only if the Adjustable frequency drive carries out a stop command.

If the Adjustable frequency drive is in alarm mode or in an overvoltage situation, the mechanical brake immediately cuts in.

In the vertical movement, the key point is that the load must be held, stopped, controlled (raised, lowered) in a perfectly safe mode during the entire operation. Because the Adjustable frequency drive is not a safety device, the crane/lift designer (OEM) must decide on the type and number of safety devices (e.g., speed switch, emergency brakes, etc.) to be used in order to be able to stop the load in case of emergency or malfunction of the system, according to relevant national crane/lift regulations.

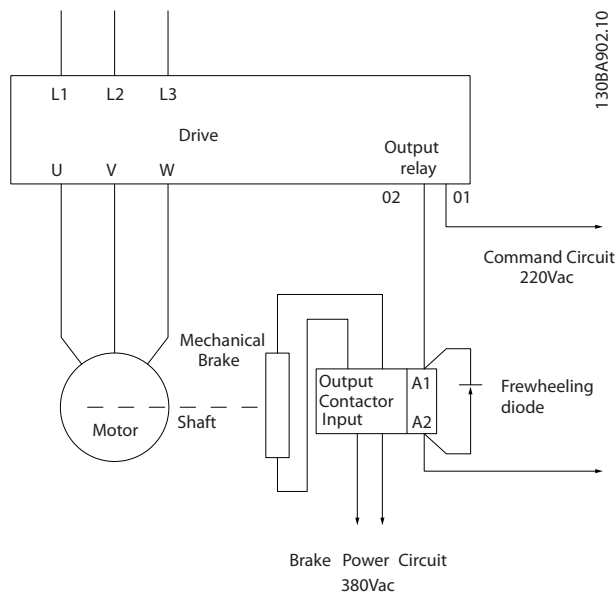

Figure 2.17 Connecting the Mechanical Brake to the Adjustable Frequency Drive

2.4.6 Serial Communication

Connect RS-485 serial communication wiring to terminals (+)68 and (-)69.

- A shielded serial communication cable is recommended
- See 2.4.2 *Grounding Requirements* for proper grounding

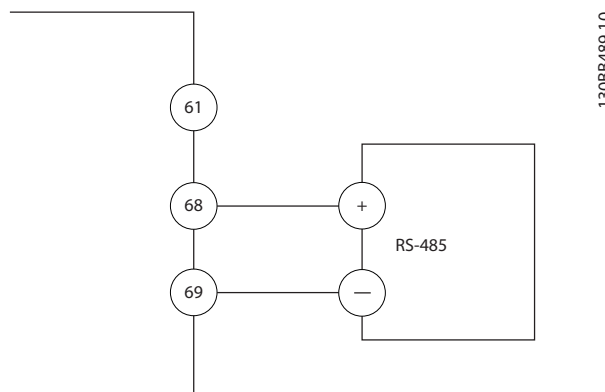

Figure 2.18 Serial Communication Wiring Diagram

For basic serial communication set-up, select the following

1. Protocol type in *8-30 Protocol*.
 2. Adjustable frequency drive address in *8-31 Address*.
 3. Baud rate in *8-32 Baud Rate*.
- Two communication protocols are internal to the adjustable frequency drive. Follow the motor manufacturer wiring requirements.
 - Danfoss FC
 - Modbus RTU
 - Functions can be programmed remotely using the protocol software and RS-485 connection or in parameter group 8-** Communications and Options.
 - Selecting a specific communication protocol changes various default parameter settings to match that protocol's specifications along with making additional protocol-specific parameters available.
 - Option cards which can be installed in the adjustable frequency drive are available to provide additional communication protocols. See the option card documentation for installation and instruction manual.

3 Start-up and Functional Testing

3.1 Pre-start

3.1.1 Safety Inspection

⚠ WARNING

HIGH VOLTAGE!

If input and output connections have been connected improperly, there is potential for high voltage on these terminals. If power leads for multiple motors are improperly run through the same conduit, there is a potential for leakage current to charge capacitors within the Adjustable frequency drive, even when disconnected from line power input. For initial start-up, make no assumptions about power components. Follow pre-start procedures. Failure to follow pre-start procedures could result in personal injury or damage to equipment.

1. Input power to the unit must be OFF and locked out. Do not rely on the Adjustable frequency drive disconnect switches for input power isolation.
2. Verify that there is no voltage on input terminals L1 (91), L2 (92), and L3 (93), phase-to-phase and phase-to-ground,
3. Verify that there is no voltage on output terminals 96 (U), 97 (V), and 98 (W), phase-to-phase and phase-to-ground.
4. Confirm continuity of the motor by measuring ohm values on U-V (96-97), V-W (97-98), and W-U (98-96).
5. Check for proper grounding of the Adjustable frequency drive as well as the motor.
6. Inspect the Adjustable frequency drive for loose connections on terminals.
7. Record the following motor nameplate data: power, voltage, frequency, full load current, and nominal speed. These values are needed to program motor nameplate data later.
8. Confirm that the supply voltage matches voltage of Adjustable frequency drive and motor.

3.1.2 Start-up Check List

CAUTION

Before applying power to the unit, inspect the entire installation as detailed in *Table 3.1*. Check mark those items when completed.

3

Inspect for	Description	<input checked="" type="checkbox"/>
Auxiliary equipment	<ul style="list-style-type: none"> Look for auxiliary equipment, switches, disconnects, or input fuses/circuit breakers that may reside on input power side of Adjustable frequency drive or output side to motor. Examine their operational readiness and ensure that they are ready in all respects for operation at full speed. Check function and installation of any sensors used for feedback to Adjustable frequency drive. Remove power factor correction caps on motor(s), if present 	
Cable routing	<ul style="list-style-type: none"> Ensure that input power, motor wiring, and control wiring are separated or in three separate metallic conduits for high frequency noise isolation. 	
Control wiring	<ul style="list-style-type: none"> Check for broken or damaged wires and loose connections. Check that control wiring is isolated from power and motor wiring for noise immunity. Check the voltage source of the signals, if necessary. The use of shielded cable or twisted pair is recommended. Ensure that the shield is terminated correctly. 	
Cooling clearance	<ul style="list-style-type: none"> Make sure that the top and bottom clearance is adequate to ensure proper airflow for cooling. 	
EMC considerations	<ul style="list-style-type: none"> Check for proper installation regarding electromagnetic compatibility. 	
Environmental considerations	<ul style="list-style-type: none"> See equipment label for the maximum ambient operating temperature limits. Humidity levels must be 5%–95% non-condensing. 	
Fusing and circuit breakers	<ul style="list-style-type: none"> Check for proper fusing or circuit breakers. Check that all fuses are inserted firmly and in operational condition and that all circuit breakers are in the open position. 	
Grounding	<ul style="list-style-type: none"> The unit requires a ground wire from its chassis to the building ground. Check for good ground connections that are tight and free of oxidation. Grounding to conduit or mounting the back panel to a metal surface is not a suitable ground. 	
Input and output power wiring	<ul style="list-style-type: none"> Check for loose connections. Check that motor and line power are in separate conduit or separated shielded cables. 	
Panel interior	<ul style="list-style-type: none"> Make sure that the unit interior is free of dirt, metal chips, moisture, and corrosion. 	
Switches	<ul style="list-style-type: none"> Ensure that all switch and disconnect settings are in the proper position. 	
Vibration	<ul style="list-style-type: none"> Check that the unit is mounted solidly or that shock mounts are used, as necessary. Check for any unusual amount of vibration the unit may be subjected to. 	

Table 3.1 Start-up Check List

3.2 Applying Power to the Adjustable Frequency Drive

⚠ WARNING

HIGH VOLTAGE!

Adjustable frequency drives contain high voltage when connected to AC line power. Installation, start-up and maintenance should be performed by qualified personnel only. Failure to perform installation, start-up and maintenance by qualified personnel could result in death or serious injury.

⚠ WARNING

UNINTENDED START!

When adjustable frequency drive is connected to AC line power, the motor may start at any time. The Adjustable frequency drive, motor, and any driven equipment must be in operational readiness. Failure to be in operational readiness when the Adjustable frequency drive is connected to AC line power could result in death, serious injury, equipment, or property damage.

1. Confirm input voltage is balanced within 3%. If not, correct input voltage imbalance before proceeding. Repeat procedure after voltage correction.
2. Ensure optional equipment wiring, if present, matches installation application.
3. Ensure that all operator devices are in the OFF position. Panel doors closed or cover mounted.
4. Apply power to the unit. DO NOT start the Adjustable frequency drive at this time. For units with a disconnect switch, turn to the ON position to apply power to the Adjustable frequency drive.

NOTE!

If the status line at the bottom of the LCP reads **AUTO REMOTE COAST**, this indicates that the unit is ready to operate but is missing an input signal on terminal 27. See *Figure 2.15* for details.

3.3 Basic Operational Programming

Adjustable frequency drives require basic operational programming prior to running for best performance. Basic operational programming requires entering motor nameplate data for the motor being operated and the minimum and maximum motor speeds. Enter data in accordance with the following procedure. Parameter settings recommended are intended for start-up and checkout purposes. Application settings may vary. See

4 *User Interface* for detailed instructions on entering data through the LCP.

Enter data with power ON, but prior to operating the adjustable frequency drive.

1. Press [Main Menu] twice on the LCP.
2. Use the navigation keys to scroll to parameter group 0-** *Operation/Display* and press [OK].

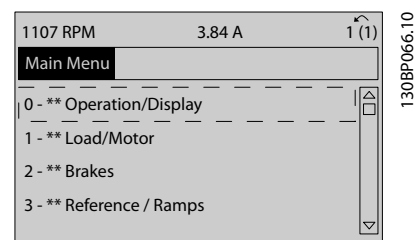

3. Use navigation keys to scroll to parameter group 0-0* *Basic Settings* and press [OK].

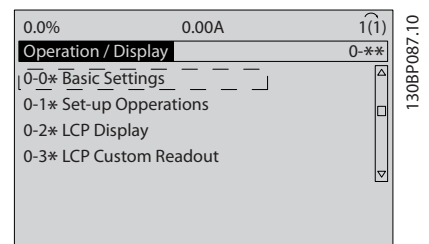

4. Use navigation keys to scroll to 0-03 *Regional Settings* and press [OK].

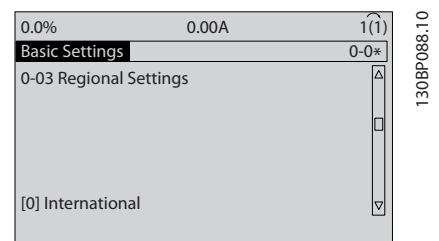

5. Use navigation keys to select *International* or *North America* as appropriate and press [OK]. (This changes the default settings for a number of basic parameters. See 5.4 *International/North American Default Parameter Settings* for a complete list.)
6. Press [Quick Menu] on the LCP.

- Use the navigation keys to scroll to parameter group Q2 Quick Setup and press [OK].



01174830E1

- Select language and press [OK]. Then enter the motor data in parameters 1-20/1-21 through 1-25. The information can be found on the motor nameplate.

1-20 Motor Power [kW] or 1-21 Motor Power [HP]

1-22 Motor Voltage

1-23 Motor Frequency

1-24 Motor Current

1-25 Motor Nominal Speed

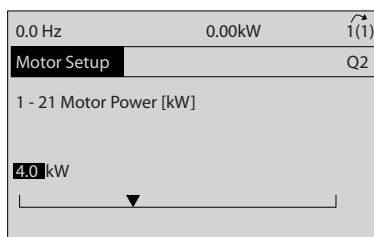

1308T772.10

- A jumper wire should be in place between control terminals 12 and 27. If this is the case, leave 5-12 Terminal 27 Digital Input at factory default. Otherwise select *No Operation*. For adjustable frequency drives with an optional Danfoss bypass, no jumper wire is required.
- 3-02 Minimum Reference
- 3-03 Maximum Reference
- 3-41 Ramp 1 Ramp-up Time
- 3-42 Ramp 1 Ramp-down Time
- 3-13 Reference Site. Linked to Hand/Auto* Local Remote.

This concludes the quick set-up procedure. Press [Status] to return to the operational display.

3.4 Automatic Motor Adaptation

Automatic motor adaptation (AMA) is a test procedure that measures the electrical characteristics of the motor to optimize compatibility between the Adjustable frequency drive and the motor.

- The Adjustable frequency drive builds a mathematical model of the motor for regulating output motor current. The procedure also tests the input phase balance of electrical power. It compares the motor characteristics with the data entered in parameters 1-20 to 1-25.
- It does not cause the motor to run or harm to the motor
- Some motors may be unable to run the complete version of the test. In that case, select *Enable reduced AMA*
- If an output filter is connected to the motor, select *Enable reduced AMA*
- If warnings or alarms occur, see 8 Warnings and Alarms
- Run this procedure on a cold motor for best results

To run AMA

- Press [Main Menu] to access parameters.
- Scroll to parameter group 1-2* Load and Motor.
- Press [OK].
- Scroll to parameter group 1-2* Motor Data.
- Press [OK].
- Scroll to 1-29 Automatic Motor Adaptation (AMA).
- Press [OK].
- Select *Enable complete AMA*.
- Press [OK].
- Follow on-screen instructions.
- The test will run automatically and indicate when it is complete.

3.5 Check Motor Rotation

Prior to running the adjustable frequency drive, check the motor rotation.

1. Press [Hands on].
2. Press [▶] for positive speed reference.
3. Check that the speed displayed is positive.

When 1-06 Clockwise Direction is set to [0]* Normal (default clockwise):

- 4a. Verify that the motor turns clockwise.
- 5a. Verify that the LCP direction arrow is clockwise.

When 1-06 Clockwise Direction is set to [1] Inverse (counter-clockwise):

- 4b. Verify that the motor turns counter-clockwise.
- 5b. Verify that the LCP direction arrow is counter-clockwise.

3.6 Check Encoder Rotation

Check encoder rotation only if encoder feedback is used. Check encoder rotation in default open-loop control.

1. Verify that the encoder connection is according to the wiring diagram:

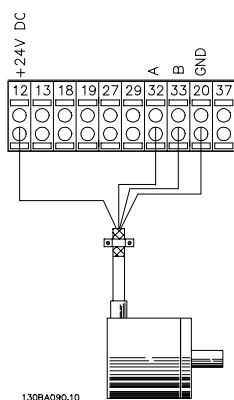

NOTE!

When using an encoder option, refer to the option manual.

2. Enter the speed PID feedback source in 7-00 Speed PID Feedback Source.
3. Press [Hand On].
4. Press [▶] for positive speed reference (1-06 Clockwise Direction at [0]* Normal).

5. Check in 16-57 Feedback [RPM] that the feedback is positive.

NOTE!

If the feedback is negative, the encoder connection is wrong!

3.7 Local Control Test

CAUTION

MOTOR START!

Ensure that the motor, system, and any attached equipment is ready for start. It is the responsibility of the user to ensure safe operation under any operational condition. Failure to ensure that the motor, system, and any attached equipment is ready for start could result in personal injury or equipment damage.

NOTE!

The hand on key on the LCP provides a local start command to the Adjustable frequency drive. The OFF key provides the stop function.

When operating in local mode, the up and down arrows on the LCP increase and decrease the speed output of the Adjustable frequency drive. The left and right arrow keys move the display cursor in the numeric display.

1. Press [Hand On].
2. Accelerate the Adjustable frequency drive by pressing [▲] to full speed. Moving the cursor left of the decimal point provides quicker input changes.
3. Note any acceleration problems.
4. Press [OFF].
5. Note any deceleration problems.

If acceleration problems were encountered

- If warnings or alarms occur, see 8 Warnings and Alarms
- Check that motor data is entered correctly
- Increase the ramp-up time in 3-41 Ramp 1 Ramp-up Time
- Increase current limit in 4-18 Current Limit
- Increase torque limit in 4-16 Torque Limit Motor Mode

If deceleration problems were encountered

- If warnings or alarms occur, see 8 *Warnings and Alarms*
- Check that motor data is entered correctly
- Increase the ramp-down time in 3-42 *Ramp 1 Ramp-down Time*
- Enable overvoltage control in 2-17 *Over-voltage Control*

See 8.4 *Warning and Alarm Definitions* for resetting the Adjustable frequency drive after a trip.

NOTE!

3.1 Pre-start through 3.7 Local Control Test in this chapter conclude the procedures for applying power to the Adjustable frequency drive, basic programming, set-up, and functional testing.

3.8 System Start-up

The procedure in this section requires user-wiring and application programming to be completed. 6 *Application Set-Up Examples* is intended to help with this task. Other aids to application set-up are listed in 1.2 *Additional Resources*. The following procedure is recommended after application set-up by the user is completed.

CAUTION

MOTOR START!

Ensure that the motor, system, and any attached equipment is ready for start. It is the responsibility of the user to ensure safe operation under any operational condition. Failure to ensure that the motor, system, and any attached equipment is ready for start could result in personal injury or equipment damage.

1. Press [Auto On].
2. Ensure that external control functions are properly wired to the Adjustable frequency drive and all programming completed.
3. Apply an external run command.
4. Adjust the speed reference throughout the speed range.
5. Remove the external run command.
6. Note any problems.

If warnings or alarms occur, see 8 *Warnings and Alarms*.

4 User Interface

4.1 Local Control Panel

The local control panel (LCP) is the combined display and keypad on the front of the unit. The LCP is the user interface to the adjustable frequency drive.

The LCP has several user functions.

- Start, stop, and control speed when in local control
- Display operational data, status, warnings and cautions
- Programming adjustable frequency drive functions
- Manually reset the adjustable frequency drive after a fault when auto-reset is inactive

An optional numeric LCP (NLCP) is also available. The NLCP operates in a manner similar to the LCP. See the Programming Guide for details on use of the NLCP.

NOTE!

The display contrast can be adjusted by pressing [STATUS] and the up/down key.

4.1.1 LCP Layout

The LCP is divided into four functional groups (see Figure 4.1).

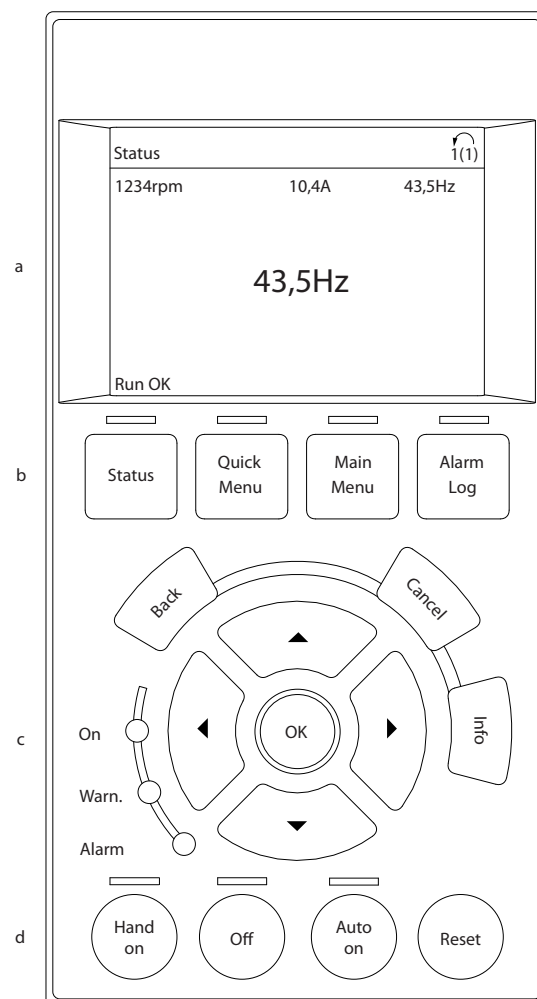

130BB465.10

Figure 4.1 LCP

- Display area.
- Display menu keys for changing the display to show status options, programming, or error message history.
- Navigation keys for programming functions, moving the display cursor, and speed control in local operation. Also included are the status indicators.
- Operational mode keys and reset.

4.1.2 Setting LCP Display Values

The display area is activated when the adjustable frequency drive receives power from AC line voltage, a DC bus terminal, or an external 24 V supply.

The information displayed on the LCP can be customized for user application.

- Each display readout has a parameter associated with it.
- Options are selected in main menu 0-2*.
- The adjustable frequency drive status at the bottom line of the display is generated automatically and is not selectable. See 7 *Status Messages* for definitions and details.

Display	Parameter number	Default setting
1.1	0-20	Speed [RPM]
1.2	0-21	Motor Current
1.3	0-22	Power [kW]
2	0-23	Frequency
3	0-24	Reference [%]

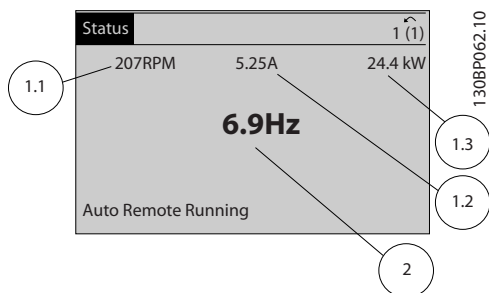
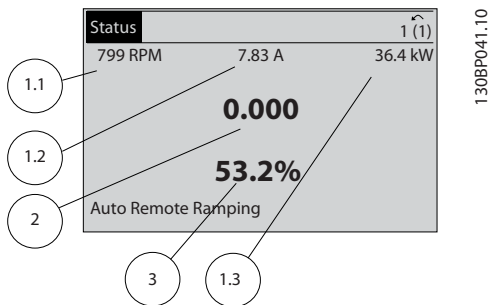

4.1.3 Display Menu Keys

Menu keys are used for menu access for parameter set-up, toggling through status display modes during normal operation, and viewing fault log data.



Key	Function
Status	<p>Press to show operational information.</p> <ul style="list-style-type: none"> • In Auto mode, press and hold to toggle between status readout displays • Press repeatedly to scroll through each status display. • Press and hold [Status] plus [▲] or [▼] to adjust the display brightness. • The symbol in the upper right corner of the display shows the direction of motor rotation and which set-up is active. This is not programmable.
Quick Menu	<p>Allows access to programming parameters for initial set-up instructions and many detailed application instructions.</p> <ul style="list-style-type: none"> • Press to access <i>Q2 Quick Setup</i> for sequenced instructions to program the basic adjustable frequency drive set-up • Follow the sequence of parameters as presented for the function set-up
Main Menu	<p>Allows access to all programming parameters.</p> <ul style="list-style-type: none"> • Press twice to access top level index. • Press once to return to the last location accessed. • Press and hold to enter a parameter number for direct access to that parameter.
Alarm Log	<p>Displays a list of current warnings, the last 10 alarms, and the maintenance log.</p> <ul style="list-style-type: none"> • For details about the adjustable frequency drive before it entered the alarm mode, select the alarm number using the navigation keys and press [OK].

4.1.4 Navigation Keys

Navigation keys are used for programming functions and moving the display cursor. The navigation keys also provide speed control in local (hand) operation. Three adjustable frequency drive status indicators are also located in this area.

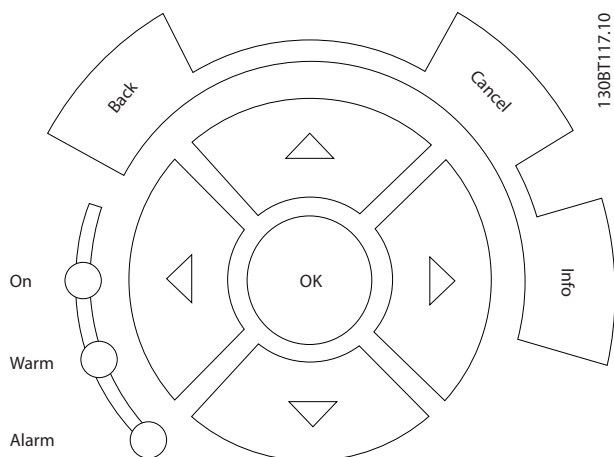

1308T117.10

Key	Function
Back	Reverts to the previous step or list in the menu structure.
Cancel	Cancels the last change or command as long as the display mode has not changed.
Info	Press for a definition of the function being displayed.
Navigation Keys	Use the four navigation arrows to move between items in the menu.
OK	Use to access parameter groups or to enable a choice.

Light	Indicator	Function
Green	ON	The ON light activates when the adjustable frequency drive receives power from AC line voltage, a DC bus terminal, or an external 24 V supply.
Yellow	WARN	When warning conditions are met, the yellow WARN light comes on and text appears in the display area identifying the problem.
Red	ALARM	A fault condition causes the red alarm light to flash and an alarm text is displayed.

4.1.5 Operation Keys

Operation keys are found at the bottom of the control panel.

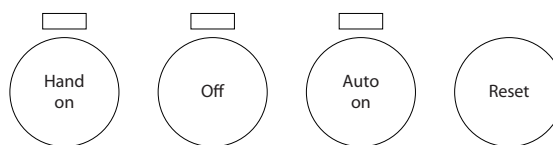

1308P046.10

Key	Function
Hand On	Press to start the adjustable frequency drive in local control. <ul style="list-style-type: none"> Use the navigation keys to control adjustable frequency drive speed. An external stop signal by control input or serial communication overrides the local hand on.
Off	Stops the motor but does not remove power to the adjustable frequency drive.
Auto On	Puts the system in remote operational mode. <ul style="list-style-type: none"> Responds to an external start command by control terminals or serial communication Speed reference is from an external source
Reset	Resets the adjustable frequency drive manually after a fault has been cleared.

4.2 Backup and Copying Parameter Settings

Programming data is stored internally in the adjustable frequency drive.

- The data can be uploaded into the LCP memory as a storage backup.
- Once stored in the LCP, the data can be downloaded back into the adjustable frequency drive.
- Or downloaded into other adjustable frequency drives by connecting the LCP into those units and downloading the stored settings. (This is a quick way to program multiple units with the same settings.)
- Initialization of the adjustable frequency drive to restore factory default settings does not change data stored in the LCP memory

⚠ WARNING**UNINTENDED START!**

When adjustable frequency drive is connected to AC line power, the motor may start at any time. The adjustable frequency drive, motor, and any driven equipment must be in operational readiness. Failure to be in operational readiness when the adjustable frequency drive is connected to AC line power could result in death, serious injury, equipment, or property damage.

4

4.2.1 Uploading Data to the LCP

1. Press [OFF] to stop the motor before uploading or downloading data.
2. Go to *0-50 LCP Copy*.
3. Press [OK].
4. Select *All to LCP*.
5. Press [OK]. A progress bar shows the uploading process.
6. Press [Hand On] or [Auto On] to return to normal operation.

4.2.2 Downloading Data from the LCP

1. Press [OFF] to stop the motor before uploading or downloading data.
2. Go to *0-50 LCP Copy*.
3. Press [OK].
4. Select *All from LCP*.
5. Press [OK]. A progress bar shows the downloading process.
6. Press [Hand On] or [Auto On] to return to normal operation.

4.3 Restoring Default Settings

CAUTION

Initialization restores the unit to factory default settings. Any programming, motor data, localization, and monitoring records will be lost. Uploading data to the LCP provides a backup prior to initialization.

Restoring the adjustable frequency drive parameter settings back to default values is done by initialization of the adjustable frequency drive. Initialization can be through *14-22 Operation Mode* or manually.

- Initialization using *14-22 Operation Mode* does not change adjustable frequency drive data such as operating hours, serial communication selections, personal menu settings, fault log, alarm log, and other monitoring functions.
- Using *14-22 Operation Mode* is generally recommended.
- Manual initialization erases all motor, programming, localization, and monitoring data and restores factory default settings.

4.3.1 Recommended Initialization

1. Press [Main Menu] twice to access parameters.
2. Scroll to *14-22 Operation Mode*.
3. Press [OK].
4. Scroll to *Initialization*.
5. Press [OK].
6. Remove power to the unit and wait for the display to turn off.
7. Apply power to the unit.

Default parameter settings are restored during start-up. This may take slightly longer than normal.

8. Alarm 80 is displayed.
9. Press [Reset] to return to operation mode.

4.3.2 Manual Initialization

1. Remove power to the unit and wait for the display to turn off.
2. Press and hold [Status], [Main Menu], and [OK] at the same time and apply power to the unit.

Factory default parameter settings are restored during start-up. This may take slightly longer than normal.

Manual initialization does not reset the following adjustable frequency drive information

- *15-00 Operating Hours*
- *15-03 Power-ups*
- *15-04 Over Temps*
- *15-05 Over Volts*

5 About Adjustable Frequency Drive Programming

5.1 Introduction

The adjustable frequency drive is programmed for its application functions using parameters. Parameters are accessed by pressing either [Quick Menu] or [Main Menu] on the LCP. (See 4 *User Interface* for details on using the LCP function keys.) Parameters may also be accessed through a PC using the MCT 10 Set-up Software (see 5.6.1 *Remote Programming with*).

The quick menu is intended for initial start up (Q2-** *Quick Set Up*). Data entered in a parameter can change the options available in the parameters following that entry.

The main menu accesses all parameters and allows for advanced adjustable frequency drive applications.

5.2 Programming Example

Here is an example for programming the adjustable frequency drive for a common application in open-loop using the quick menu.

- This procedure programs the adjustable frequency drive to receive a 0–10 V DC analog control signal on input terminal 53
- The adjustable frequency drive will respond by providing 6–60 Hz output to the motor proportional to the input signal (0–10V DC = 6–60 Hz).

Select the following parameters using the navigation keys to scroll to the titles and press [OK] after each action.

1. 3-15 *Reference Resource 1*

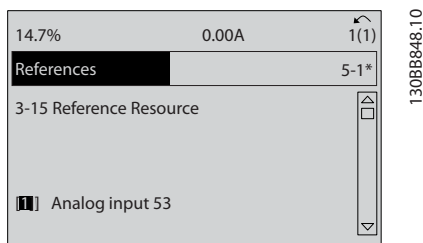

2. 3-02 *Minimum Reference*. Set minimum internal adjustable frequency drive reference to 0 Hz. (This sets the minimum adjustable frequency drive speed at 0 Hz.)

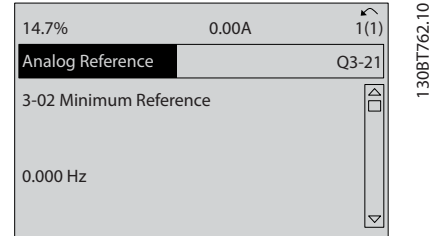

3. 3-03 *Maximum Reference*. Set maximum internal adjustable frequency drive reference to 60 Hz. (This sets the maximum adjustable frequency drive speed at 60 Hz. Note that 50/60 Hz is a regional variation.)

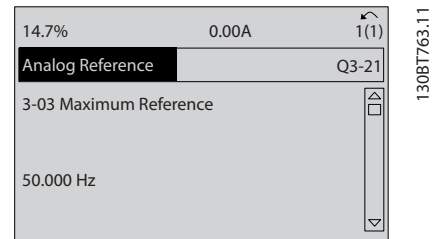

4. 6-10 *Terminal 53 Low Voltage*. Set minimum external voltage reference on Terminal 53 at 0V. (This sets the minimum input signal at 0 V.)

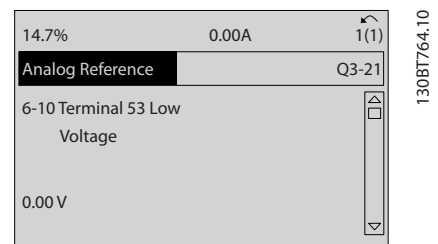

5. 6-11 *Terminal 53 High Voltage*. Set maximum external voltage reference on Terminal 53 at 10 V. (This sets the maximum input signal at 10V.)

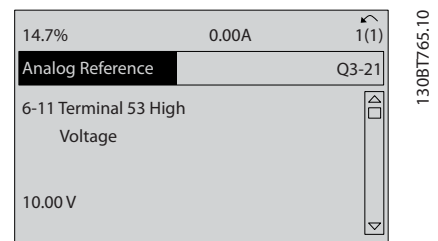

- 6-14 Terminal 53 Low Ref./Feedb. Value. Set minimum speed reference on Terminal 53 at 6Hz. (This tells the adjustable frequency drive that the minimum voltage received on Terminal 53 (0 V) equals 6 Hz output.)

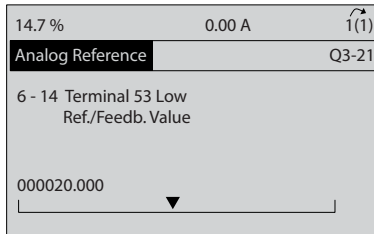

130BT773.11

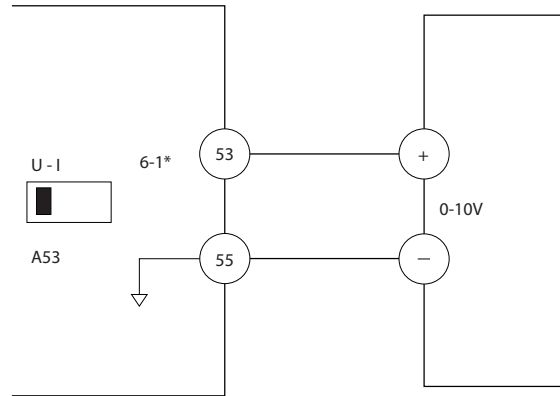
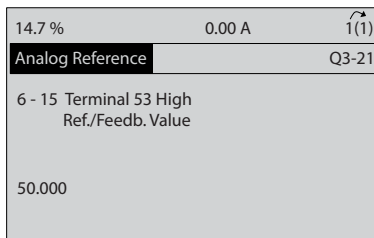

Figure 5.1 Wiring Example for External Device Providing 0–10V Control Signal (adjustable frequency drive left, external device right)

- 6-15 Terminal 53 High Ref./Feedb. Value. Set maximum speed reference on Terminal 53 at 60 Hz. (This tells the adjustable frequency drive that the maximum voltage received on Terminal 53 (10 V) equals 60 Hz output.)



130BT774.11

With an external device providing a 0–10 V control signal connected to adjustable frequency drive terminal 53, the system is now ready for operation. Note that the scroll bar on the right in the last figure of the display is at the bottom, indicating the procedure is complete.

Figure 5.1 shows the wiring connections used to enable this set-up.

5.3 Control Terminal Programming Examples

Control terminals can be programmed.

- Each terminal has specified functions it is capable of performing.
- Parameters associated with the terminal enable the function.
- For proper Adjustable frequency drive functioning, the control terminals must be
 - wired properly
 - Programmed for the intended function
 - Receiving a signal

See Table 2.3 for control terminal parameter number and default setting. (Default setting can change based on the selection in 0-03 Regional Settings.)

The following example shows accessing Terminal 18 to see the default setting.

1. Press [Main Menu] twice, scroll to parameter group 5-** Digital In/Out and press [OK].

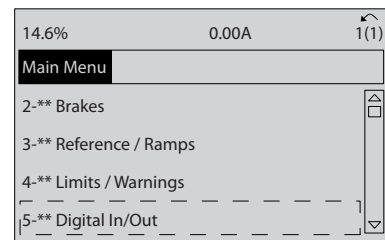

130BT768.10

2. Scroll to parameter group 5-1* *Digital Inputs* and press [OK].

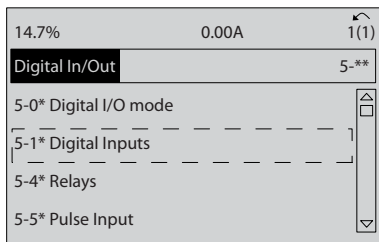

130BT769.10

3. Scroll to 5-10 *Terminal 18 Digital Input*. Press [OK] to access function choices. The default setting *Start* is shown.

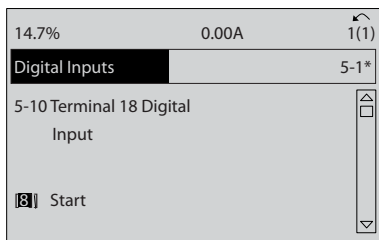

130BT770.10

5.4 International/North American Default Parameter Settings

Setting 0-03 *Regional Settings* to [0] *International* or [1] *North America* changes the default settings for some parameters. Table 5.1 lists those parameters that are effected.

Parameter	International default parameter value	North American default parameter value
0-03 Regional Settings	International	North America
1-20 Motor Power [kW]	See Note 1	See Note 1
1-21 Motor Power [HP]	See Note 2	See Note 2
1-22 Motor Voltage	230V/400V/575V	208V/460V/575V
1-23 Motor Frequency	50Hz	60Hz
3-03 Maximum Reference	50Hz	60Hz
3-04 Reference Function	Sum	External/Preset
4-13 Motor Speed High Limit [RPM] See Note 3 and 5	1500 RPM	1800 RPM

Parameter	International default parameter value	North American default parameter value
4-14 Motor Speed High Limit [Hz] See Note 4	50Hz	60Hz
4-19 Max Output Frequency	132Hz	120Hz
4-53 Warning Speed High	1500 RPM	1800 RPM
5-12 Terminal 27 Digital Input	Coast inverse	External interlock
5-40 Function Relay	No operation	No alarm
6-15 Terminal 53 High Ref./Feedb. Value	50	60
6-50 Terminal 42 Output	No operation	Speed 4-20 mA
14-20 Reset Mode	Manual reset	Infinite auto reset

Table 5.1 International/North American Default Parameter Settings

Note 1: 1-20 Motor Power [kW] is only visible when 0-03 *Regional Settings* is set to [0] *International*.

Note 2: 1-21 Motor Power [HP], is only visible when 0-03 *Regional Settings* is set to [1] *North America*.

Note 3: This parameter is only visible when 0-02 *Motor Speed Unit* is set to [0] *RPM*.

Note 4: This parameter is only visible when 0-02 *Motor Speed Unit* is set to [1] *Hz*.

Note 5: The default value depends on the number of motor poles. For a 4-poled motor, the international default value is 1500 RPM and for a 2-poled motor, 3000 RPM. The corresponding values for North America is 1800 RPM and 3600 RPM, respectively.

Changes made to default settings are stored and available for viewing in the quick menu along with any programming entered into parameters.

1. Press [Quick Menu].
2. Scroll to Q5 *Changes Made* and press [OK].

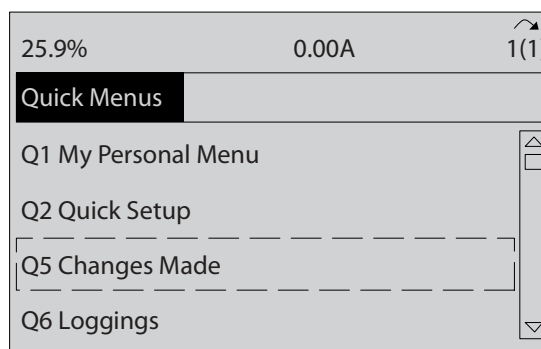

130BB849.10

3. Select Q5-2 *Since Factory Setting* to view all programming changes or Q5-1 *Last 10 Changes* for the most recent.



5

5.5 Parameter Menu Structure

Establishing the correct programming for applications often requires setting functions in several related parameters. These parameter settings provide the Adjustable frequency drive with system details for the Adjustable frequency drive to operate properly. System details may include such things as input and output signal types, programming terminals, minimum and maximum signal ranges, custom displays, automatic restart, and other features.

- See the LCP display to view detailed parameter programming and setting options.
- Press [Info] in any menu location to view additional details for that function.
- Press and hold [Main Menu] to enter a parameter number for direct access to that parameter.
- Details for common application set ups are provided in *6 Application Set-Up Examples*.

5.5.1 Main Menu Structure	1-20 Motor Power [kW]	1-94 ATEX ETR cur.lim. speed reduction	3-48 Ramp 1 S-ramp Ratio at Decel. End	4-36 Tracking Error Timeout
0-0* Operation/Display	1-21 Motor Power [HP]	1-95 KTY Sensor Type	3-5* Ramp 2	4-37 Tracking Error Ramping
0-0* Basic Settings	1-22 Motor Voltage	1-96 KTY Thermistor Resource	3-50 Ramp 2 Type	4-38 Tracking Error Ramping Timeout
0-01 Language	1-23 Motor Frequency	1-97 KTY Threshold level	3-51 Ramp 2 Ramp-up Time	4-39 Adj. Warnings
0-02 Motor Speed Unit	1-24 Motor Current	1-98 ATEX ETR interpol. points freq.	3-52 Ramp 2 Ramp-down Time	4-50 Warning Current Low
0-03 Regional Settings	1-25 Motor Nominal Speed	1-99 ATEX ETR interpol. points current	3-55 Ramp 2 S-ramp Ratio at Accel. Start	4-51 Warning Current High
0-04 Operating State at Power-up (Hand)	1-26 Motor Cont. Rated Torque	2-0* Brakes	3-56 Ramp 2 S-ramp Ratio at Decel. Start	4-52 Warning Speed Low
0-09 Performance Monitor	1-29 Automatic Motor Adaptation (AMA)	2-0* DC Brake	3-58 Ramp 2 S-ramp Ratio at Decel. End	4-53 Warning Speed High
0-1* Set-up Operations	1-30 Rotor Resistance (Rs)	2-01 DC Hold Current	3-6* Ramp 3	4-54 Warning Reference Low
0-10 Active Set-up	1-31 Rotor Resistance (Rr)	2-01 DC Brake Current	3-60 Ramp 3 Type	4-55 Warning Reference High
0-11 Edit Set-up	1-33 Stator Leakage Reactance (X1)	2-02 DC Braking Time	3-61 Ramp 3 Ramp up Time	4-56 Warning Feedback Low
0-12 This Set-up Linked to	1-34 Rotor Leakage Reactance (X2)	2-03 DC Brake Cut-in Speed [RPM]	3-62 Ramp 3 Ramp-down Time	4-57 Warning Feedback High
0-13 Readout: Linked Set-ups	1-35 Main Reactance (Xh)	2-04 DC Brake Cut-in Speed [Hz]	3-65 Ramp 3 S-ramp Ratio at Accel. Start	4-58 Missing Motor Phase Function
0-14 Readout: Edit Set-ups / Channel	1-36 Iron Loss Resistance (Rfe)	2-05 Maximum Reference	3-66 Ramp 3 S-ramp Ratio at Accel. End	4-6* Speed Bypass
0-2* LCP Display	1-37 d-axis Inductance (Ld)	2-1* Brake Energy Func.	3-67 Ramp 3 S-ramp Ratio at Decel. Start	4-60 Bypass Speed From [RPM]
0-20 Display Line 1: Small	1-39 Motor Poles	2-10 Brake Function	3-7* Ramp 4	4-61 Bypass Speed To [RPM]
0-21 Display Line 1:2 Small	1-40 Back EMF at 1000 RPM	2-12 Brake Power Limit (kW)	3-70 Ramp 4 Type	4-62 Bypass Speed To [Hz]
0-22 Display Line 1:3 Small	1-41 Motor Angle Offset	2-13 Brake Power Monitoring	3-71 Ramp 4 Ramp-up Time	4-63 Bypass Speed To [Hz]
0-23 Display Line 2 Large	1-5* Load Indep. Setting	2-15 Brake Check	3-72 Ramp 4 Ramp-down Time	5-0* Digital I/O mode
0-24 Display Line 3 Large	1-50 Motor Magnetization at Zero Speed	2-16 AC brake Max. Current	3-75 Ramp 4 S-ramp Ratio at Accel. Start	5-00 Digital I/O Mode
0-25 My Personal Menu	1-51 Min Speed Normal Magnetizing [RPM]	2-17 Over-voltage Control	3-76 Ramp 4 S-ramp Ratio at Accel. End	5-01 Terminal 27 Mode
0-3* LCP Custom Readout	1-52 Min Speed Normal Magnetizing [Hz]	2-18 Brake Check Condition	3-77 Ramp 4 S-ramp Ratio at Decel. Start	5-02 Terminal 29 Mode
0-30 Unit for User-defined Readout	1-53 Model Shift Frequency	2-19 Overvoltage Gain	3-78 Ramp 4 S-ramp Ratio at Decel. End	5-1* Digital Inputs
0-31 Min Value of User-defined Readout	1-54 Voltage reduction in fieldweakening	2-2* Mechanical Brake	3-80 Jog Ramp Time	5-10 Terminal 18 Digital Input
0-32 Max Value of User-defined Readout	1-55 U/f Characteristic - U	2-20 Release Brake Current	3-81 Quick Stop Ramp Time	5-11 Terminal 19 Digital Input
0-33 Display Text 1	1-56 U/f Characteristic - F	2-21 Activate Brake Speed [RPM]	3-82 Quick Stop Ramp Type	5-12 Terminal 27 Digital Input
0-38 Display Text 2	1-58 Flystart Test Pulses Frequency	2-22 Activate Brake Speed [Hz]	3-83 Quick Stop S-ramp Ratio at Decel. Start	5-13 Terminal 29 Digital Input
0-39 Display Text 3	1-6* Load Depen. Setting	2-23 Activate Brake Delay	3-84 Quick Stop S-ramp Ratio at Decel. End	5-14 Terminal 32 Digital Input
0-4* LCP Keypad	1-60 Low Speed Load Compensation	2-24 Stop Delay	3-9* Digital Pot.Meter	5-15 Terminal 33 Digital Input
0-40 [Hand on] Key on LCP	1-61 High Speed Load Compensation	2-25 Brake Release Time	3-90 Step Size	5-16 Terminal X30/2 Digital Input
0-41 [Off] Key on LCP	1-62 Slip Compensation	2-26 Torque Ref	3-90 Ramp Time	5-17 Terminal X30/3 Digital Input
0-42 [Auto on] Key on LCP	1-63 Slip Compensation Time Constant	2-27 Torque Ramp Time	3-92 Power Restore	5-18 Terminal X30/4 Digital Input
0-43 [Reset] Key on LCP	1-64 Resonance Dampening	2-28 Gain Boost Factor	3-93 Maximum Limit	5-19 Terminal 37 Safe Stop
0-44 [Off/Reset] Key on LCP	1-65 Resonance Dampening Time Constant	3-0* Reference / Ramps	3-94 Minimum Limit	5-20 Terminal X46/1 Digital Input
0-45 [Drive Bypass] Key on LCP	1-66 Min. Current at Low Speed	3-0* Reference Range	3-95 Ramp Delay	5-21 Terminal X46/3 Digital Input
0-5* Copy/Save	1-67 Load Type	3-01 Reference/Feedback Unit	4-1* Limits / Warnings	5-22 Terminal X46/5 Digital Input
0-50 LCP Copy	1-68 Minimum Inertia	3-02 Minimum Reference	4-1* Motor Limits	5-23 Terminal X46/7 Digital Input
0-51 Set-up Copy	1-69 Maximum Inertia	3-03 Maximum Reference	4-10 Motor Speed Direction	5-24 Terminal X46/9 Digital Input
0-6* Password	1-7* Start Adjustments	3-04 Reference Function	4-11 Motor Speed Low Limit [RPM]	5-25 Terminal X46/11 Digital Input
0-60 Main Menu Password	1-71 Start Delay	3-1* References	4-12 Motor Speed Low Limit [Hz]	5-26 Terminal X46/13 Digital Input
0-61 Access to Main Menu w/o Password	1-72 Start Function	3-10 Preset Reference	4-13 Motor Speed High Limit [RPM]	5-3* Digital Outputs
0-65 Quick Menu Password	1-73 Flying Start	3-11 Jog Speed [Hz]	4-14 Motor Speed High Limit [Hz]	5-30 Terminal 27 Digital Output
0-66 Access to Quick Menu w/o Password	1-74 Start Speed [RPM]	3-12 Catch up/slow-down value	4-16 Torque Limit Motor Mode	5-31 Terminal 29 Digital Output
0-67 Bus Password Access	1-75 Start Speed [Hz]	3-13 Reference Site	4-17 Torque Limit Generator Mode	5-32 Term X30/6 Digi Out (MCB 101)
1-0* Load and Motor	1-76 Start Current	3-14 Preset Relative Reference	4-18 Current Limit	5-33 Term X30/7 Digi Out (MCB 101)
1-00 Configuration Mode	1-8* Stop Adjustments	3-15 Reference Resource 1	4-19 Max Output Frequency	5-4* Relays
1-01 Motor Control Principle	1-80 Function at Stop	3-16 Reference Resource 2	4-20 Torque Limit Factor Source	5-40 Function Relay
1-02 Flux Motor Feedback Source	1-81 Min Speed for Function at Stop [RPM]	3-17 Reference Resource 3	4-21 Speed Limit Factor Source	5-41 On Delay, Relay
1-03 Torque Characteristics	1-82 Min Speed for Function at Stop [Hz]	3-18 Relative Scaling Reference Resource	4-22 Torque Limit	5-42 Off Delay, Relay
1-04 Overload Mode	1-83 Precise Stop Function	3-19 Jog Speed [RPM]	4-3* Motor Speed Mon.	5-5* Pulse Input
1-05 Local Mode Configuration	1-84 Precise Stop Counter Value	3-4* Ramp 1	4-30 Motor Feedback Loss Function	5-50 Term. 29 Low Frequency
1-06 Clockwise Direction	1-85 Precise Stop Speed Compensation Delay	3-40 Ramp 1 Type	4-31 Motor Feedback Speed Error	5-51 Term. 29 High Frequency
1-1* Motor Selection	1-90 Motor Temperature	3-41 Ramp 1 Ramp-up Time	4-32 Motor Feedback Loss Timeout	5-52 Term. 29 Low Ref./Feedb. Value
1-10 Motor Construction	1-91 Motor Thermal Protection	3-42 Ramp 1 Ramp-down Time	4-34 Tracking Error Function	5-53 Term. 29 High Ref./Feedb. Value
1-2* Motor Data	1-93 Thermistor Resource	3-46 Ramp 1 S-ramp Ratio at Accel. End	4-35 Tracking Error	5-54 Pulse Filter Time Constant #29
		3-47 Ramp 1 S-ramp Ratio at Decel. Start		5-55 Term. 33 Low Frequency
				5-56 Term. 33 High Frequency

5-57	Term. 33 Low Ref./Feedb. Value	6-55	Analog Output Filter	7-5*	Adv. Process PID II	9-22	Telegram Selection	12-0*	IP Settings
5-58	Term. 33 High Ref./Feedb. Value	6-6*	Analog Output 2	7-50	Process PID Extended PID	9-23	Parameters for Signals	12-00	IP Address Assignment
5-59	Pulse Filter Time Constant #33	6-60	Terminal X30/8 Output	7-51	Process PID Feed Fwd Gain	9-27	Parameter Edit	12-01	IP Address
5-6*	Pulse Output	6-61	Terminal X30/8 Min. Scale	7-52	Process PID Feed Fwd Ramp-up	9-28	Process Control	12-02	Subnet Mask
5-60	Terminal 27 Pulse Output Variable	6-62	Terminal X30/8 Max. Scale	7-53	Process PID Feed Fwd Ramp-down	9-44	Fault Message Counter	12-03	Default Gateway
5-62	Pulse Output Max Freq #27	6-63	Terminal X30/8 Bus Control	7-56	Process PID Ref. Filter Time	9-45	Fault Code	12-04	DHCP Server
5-63	Terminal 29 Pulse Output Variable	6-64	Terminal X30/8 Output Timeout Preset	7-57	Process PID Fb. Filter Time	9-47	Fault Number	12-05	Lease Expires
5-65	Pulse Output Max Freq #29	6-7*	Analog Output 3	8-*	Comm. and Options	9-52	Fault Situation Counter	12-06	Name Servers
5-66	Terminal X30/6 Pulse Output Variable	6-7*	Analog Output 3	8-0*	General Settings	9-53	Profibus Warning Word	12-07	Domain Name
5-68	Pulse Output Max Freq #X30/6	6-70	Terminal X45/1 Output	8-01	Control Site	9-63	Actual Baud Rate	12-08	Host Name
5-7*	24V Encoder Input	6-71	Terminal X45/1 Min. Scale	8-02	Control Word Source	9-64	Device Identification	12-09	Physical Address
5-70	Term 32/33 Pulses per Revolution	6-72	Terminal X45/1 Max. Scale	8-03	Control Word Timeout Time	9-65	Profile Number	12-1*	Ethernet Link Parameters
5-71	Term 32/33 Encoder Direction	6-73	Terminal X45/1 Bus Control	8-04	Control Word Timeout Function	9-67	Control Word 1	12-10	Link Status
5-7*	Bus Controlled	6-74	Terminal X45/1 Output Timeout Preset	8-05	End-of-Timeout Function	9-68	Status Word 1	12-11	Link Duration
5-90	Digital & Relay Bus Control	6-8*	Analog Output 4	8-06	Reset Control Word Timeout	9-71	Profibus Save Data Values	12-12	Auto Negotiation
5-93	Pulse Out #27 Bus Control	6-80	Terminal X45/3 Output	8-07	Diagnosis Trigger	9-72	ProfibusDriveReset	12-13	Link Speed
5-94	Pulse Out #27 Timeout Preset	6-81	Terminal X45/3 Min. Scale	8-08	Readout Filtering	9-75	DO Identification	12-14	Link Duplex
5-95	Pulse Out #29 Bus Control	6-82	Terminal X45/3 Max. Scale	8-1*	Ctrl. Word Settings	9-80	Defined Parameters (1)	12-2*	Process Data
5-96	Pulse Out #29 Timeout Preset	6-83	Terminal X45/3 Bus Control	8-10	Control Word Profile	9-81	Defined Parameters (2)	12-20	Control Instance
5-97	Pulse Out #X30/6 Bus Control	6-83	Terminal X45/3 Max. Scale	8-13	Configurable Status Word STM	9-82	Defined Parameters (3)	12-21	Process Data Config Write
5-98	Pulse Out #X30/6 Timeout Preset	6-84	Terminal X45/3 Output Timeout Preset	8-14	Configurable Control Word CTW	9-83	Defined Parameters (4)	12-22	Process Data Config Read
6-0*	Analog I/O Mode	7-*	Controllers	8-3*	FC Port Settings	9-84	Defined Parameters (5)	12-23	Process Data Config Write Size
6-00	Live Zero Timeout Time	7-0*	Speed PID Ctrl.	8-30	Protocol	9-90	Changed Parameters (1)	12-24	Process Data Config Read Size
6-1*	Live Zero Timeout Function	7-00	Speed PID Feedback Source	8-31	Address	9-91	Changed Parameters (2)	12-27	Primary Master
6-10	Terminal 53 Low Voltage	7-02	Speed PID Proportional Gain	8-32	FC Port Baud Rate	9-92	Changed Parameters (3)	12-28	Store Data Values
6-11	Terminal 53 High Voltage	7-03	Speed PID Integral Time	8-33	Parity / Stop Bits	9-93	Changed parameters (4)	12-29	Store Always
6-12	Terminal 53 Low Current	7-04	Speed PID Differentiation Time	8-34	Estimated cycle time	9-94	Changed parameters (5)	12-3*	EtherNet/IP
6-13	Terminal 53 High Current	7-05	Speed PID Diff. Gain Limit	8-35	Minimum Response Delay	9-99	Profibus Revision Counter	12-30	Warning Parameter
6-14	Terminal 53 Low Ref./Feedb. Value	7-06	Speed PID Low-pass Filter Time	8-36	Max Response Delay	10-*	CAN Fieldbus	12-31	Net Reference
6-15	Terminal 53 High Ref./Feedb. Value	7-07	Speed PID Feedback Gear Ratio	8-37	Max Inter-Char Delay	10-0*	Common Settings	12-32	Net Control
6-16	Terminal 53 Filter Time Constant	7-1*	Torque PI Ctrl.	8-4*	FC MC protocol set	10-00	CAN Protocol	12-33	CIP Revision
6-20	Terminal 54 Low Voltage	7-12	Torque PI Proportional Gain	8-40	Telegram selection	10-01	Baud Rate Select	12-34	CIP Product Code
6-21	Terminal 54 High Voltage	7-13	Torque PI Integration Time	8-41	Parameters for signals	10-02	MAC ID	12-35	EDS Parameter
6-22	Terminal 54 Low Current	7-20	Process CL Feedback 2 Resource	8-42	PCD write configuration	10-05	Readout Transmit Error Counter	12-38	COS Filter
6-23	Terminal 54 High Current	7-2*	Process Ctrl. Feedb	8-43	PCD read configuration	10-06	Readout Receive Error Counter	12-4*	Modbus TCP
6-24	Terminal 54 Low Ref./Feedb. Value	7-22	Process CL Feedback 1 Resource	8-50	Coasting Select	10-07	Readout Bus Off Counter	12-40	Status Parameter
6-25	Terminal 54 High Ref./Feedb. Value	7-23*	Process PID Ctrl.	8-51	Quick Stop Select	10-10	Process Data Type Selection	12-41	Slave Message Count
6-26	Terminal 54 Filter Time Constant	7-30	Process PID Normal/ Inverse Control	8-52	DC Brake Select	10-11	Process Data Config Write	12-42	Slave Exception Message Count
6-3*	Analog Input 53	7-31	Process PID Anti Windup	8-53	Start Select	10-12	Process Data Config Read	12-5*	EtherCAT
6-30	Terminal X30/11 Low Voltage	7-32	Process PID Start Speed	8-54	Reversing Select	10-13	Warning Parameter	12-50	Configured Station Alias
6-31	Terminal X30/11 High Voltage	7-33	Process PID Proportional Gain	8-55	Set-up Select	10-14	Net Reference	12-59	EtherCAT Status
6-34	Term. X30/11 Low Ref./Feedb. Value	7-34	Process PID Integral Time	8-56	Preset Reference Select	10-15	Net Control	12-8*	Other Ethernet Services
6-35	Term. X30/11 High Ref./Feedb. Value	7-35	Process PID Differentiation Time	8-57	Profound OFF2 Select	10-20	COS Filter 1	12-80	FTP Server
6-36	Term. X30/11 Filter Time Constant	7-36	Process PID Diff. Gain Limit	8-58	Profound OFF3 Select	10-21	COS Filter 2	12-81	HTTP Server
6-4*	Analog Input 4	7-38	Process PID Feed Forward Factor	8-80	Bus Message Count	10-22	COS Filter 3	12-82	SMTP Service
6-40	Terminal X30/12 Low Voltage	7-39	On Reference Bandwidth	8-81	Bus Error Count	10-23	COS Filter 4	12-89	Transparent Socket Channel Port
6-41	Terminal X30/12 High Voltage	7-4*	Adv. Process PID I	8-82	Slave Messages Rcvd	10-30	Parameter Access	12-9*	Advanced Ethernet Services
6-44	Term. X30/12 Low Ref./Feedb. Value	7-40	Process PID I-part Reset	8-83	Slave Error Count	10-30	Array Index	12-90	Cable Diagnostic
6-45	Term. X30/12 High Ref./Feedb. Value	7-41	Process PID Output Neg. Clamp	8-9*	Bus Jog	10-31	Store Data Values	12-91	Auto Cross Over
6-46	Term. X30/12 Filter Time Constant	7-42	Process PID Output Pos. Clamp	8-90	Bus Jog 1 Speed	10-32	DeviceNet Revision	12-92	IGMP Snooping
6-50	Terminal 42 Output	7-43	Process PID Gain Scale at Min. Ref.	8-91	Bus Jog 2 Speed	10-33	Store Always	12-93	Cable Error Length
6-51	Terminal 42 Output Min Scale	7-44	Process PID Gain Scale at Max. Ref.	9-00	Setpoint	10-34	DeviceNet Product Code	12-94	Broadcast Storm Protection
6-52	Terminal 42 Output Max Scale	7-45	Process PID Feed Fwd Resource	9-07	Actual Value	10-39	DeviceNet F Parameters	12-95	Broadcast Storm Filter
6-53	Term 42 Output Bus Ctrl	7-46	Process PID Feed Fwd Normal/ Inv. Ctrl.	9-15	PCD Write Configuration	10-5*	CANopen	12-96	Port Config
6-54	Terminal 42 Output Timeout Preset	7-48	PCD Feed Forward	9-16	PCD Read Configuration	10-50	Process Data Config Write	12-98	Interface Counters
		7-49	Process PID Output Normal/ Inv. Ctrl.	9-18	Node Address	10-51	Process Data Config Read	12-99	Media Counters

13-0* SLC Settings	14-56 Capacitance Output Filter	15-73 Slot B Option SW Version	16-66 Digital Output [bin]	18-93 Process PID Gain Scaled Output
13-00 SL Controller Mode	14-57 Inductance Output Filter	15-74 Option in Slot C0	16-67 Freq. Input #29 [Hz]	30-** Special Features
13-01 Start Event	14-59 Actual Number of Inverter Units	15-75 Slot C0 Option SW Version	16-68 Freq. Input #33 [Hz]	30-0* Wobbler
13-02 Reset	14-7* Compatibility	15-76 Option in Slot C1	16-69 Pulse Output #27 [Hz]	30-00 Wobble Mode
13-03 Servo SLC	14-72 Legacy Alarm Word	15-77 Slot C1 Option SW Version	16-70 Pulse Output #29 [Hz]	30-01 Wobble Delta Frequency [Hz]
13-1* Comparators	14-73 Legacy Warning Word	15-9* Parameter Info	16-71 Relay Output [bin]	30-02 Wobble Delta Frequency [%]
13-10 Comparator Operand	14-8* Options	15-92 Defined Parameters	16-72 Counter A	30-03 Wobble Delta Freq. Scaling Resource
13-11 Comparator Operator	14-74 Leg. Ext. Status Word	15-93 Modified Parameters	16-73 Counter B	30-04 Wobble Jump Frequency [Hz]
13-12 Comparator Value	14-80 Option Supplied by External 24VDC	15-98 Drive Identification	16-74 Prec. Stop Counter	30-05 Wobble Jump Frequency [%]
13-2* Timers	14-89 Option Detection	15-99 Parameter Metadata	16-75 Analog In X30/11	30-06 Wobble Jump Time
13-20 SL Controller Timer	14-9* Fault Settings	16-** Data Readouts	16-76 Analog In X30/12	30-07 Wobble Sequence Time
13-4* Logic Rules	14-90 Fault Level	16-0* General Status	16-77 Analog Out X30/8 [mA]	30-08 Wobble Up/Down Time
13-40 Logic Rule Boolean 1	15-** Drive Information	16-00 Control Word	16-78 Analog Out X45/1 [mA]	30-09 Wobble Random Function
13-41 Logic Rule Operator 1	15-0* Operating Data	16-01 Reference [Unit]	16-79 Analog Out X45/3 [mA]	30-10 Wobble Ratio
13-42 Logic Rule Boolean 2	15-00 Operating Hours	16-02 Reference %	16-8* Fieldbus & FC Port	30-11 Wobble Random Ratio Max.
13-43 Logic Rule Operator 2	15-01 Running Hours	16-03 Status Word	16-80 Fieldbus CTW 1	30-12 Wobble Random Ratio Min.
13-44 Logic Rule Boolean 3	15-02 kWh Counter	16-05 Main Actual Value [%]	16-82 Fieldbus REF 1	30-19 Wobble Delta Freq. Scaled
13-5* States	15-03 Power-ups	16-09 Custom Readout	16-84 Comm. Option STW	30-2* Adv. Start Adjust
13-51 SL Controller Event	15-04 Over Temps	16-1* Motor Status	16-85 FC Port CTW 1	30-20 High Starting Torque Time [s]
13-52 SL Controller Action	15-05 Over Volts	16-10 Power [kW]	16-86 FC Port REF 1	30-21 High Starting Torque Current [%]
14-** Special Functions	15-06 Reset kWh Counter	16-11 Power [hp]	16-9* Diagnosis Readouts	30-22 Locked Rotor Protection
14-0* Inverter Switching	15-07 Reset Running Hours Counter	16-12 Motor Voltage	16-90 Alarm Word	30-23 Locked Rotor Detection Time [s]
14-00 Switching Pattern	15-1* Data Log Settings	16-13 Frequency	16-91 Alarm Word 2	30-8* Compatibility (I)
14-01 Switching Frequency	15-10 Logging Source	16-14 Motor Current	16-92 Warning Word	30-80 d-axis Inductance (Ld)
14-03 Overmodulation	15-11 Logging Interval	16-15 Frequency [%]	16-93 Warning Word 2	30-81 Brake Resistor (ohm)
14-04 PWM Random	15-12 Trigger Event	16-16 Torque [Nm]	16-94 Ext. Status Word	30-83 Speed PID Proportional Gain
14-06 Dead Time Compensation	15-13 Logging Mode	16-17 Speed [RPM]	17-** Feedback Option	30-84 Process PID Proportional Gain
14-1* Mains On/Off	15-14 Samples Before Trigger	16-18 Motor Thermal	17-1* Inc. Enc. Interface	31-** Bypass Option
14-10 Line Failure	15-2* Historic Log	16-19 KTY sensor temperature	17-10 Signal Type	31-00 Bypass Mode
14-11 AC line voltage at line power fault	15-20 Historic Log: Event	16-20 Motor Angle	17-11 Resolution (PPR)	31-01 Bypass Start Time Delay
14-12 Function at Line power Imbalance	15-21 Historic Log: Value	16-21 Torque [%] High Res.	17-2* Abs. Enc. Interface	31-02 Bypass Trip Time Delay
14-13 Line Failure Step Factor	15-22 Historic Log: Time	16-22 Torque [%]	17-20 Protocol Selection	31-03 Test Mode Activation
14-14 Kin. Backup Timeout	15-3* Fault Log	16-25 Torque [Nm] High	17-21 Resolution (Positions/Rev)	31-10 Bypass Status Word
14-2* Trip Reset	15-30 Fault Log: Error Code	16-3* Drive Status	17-24 SSI Data Length	31-11 Bypass Running Hours
14-20 Reset Mode	15-31 Fault Log: Value	16-30 DC Link Voltage	17-25 Clock Rate	31-19 Remote Bypass Activation
14-21 Automatic Restart Time	15-32 Fault Log: Time	16-33 Brake Energy /s	32-** MCO Basic Settings	32-0* Encoder 2
14-22 Operation Mode	15-4* Drive Identification	16-34 Brake Energy /2 min	32-00 Incremental Signal Type	32-01 Incremental Resolution
14-23 Typecode Setting	15-40 FC Type	16-34 Heatsink Temp.	32-02 Absolute Resolution	32-03 Absolute Resolution
14-24 Trip Delay at Current Limit	15-41 Power Section	16-35 Inverter Thermal	32-04 Absolute Encoder Baud Rate X55	32-05 Absolute Encoder Data Length
14-25 Trip Delay at Torque Limit	15-42 Voltage	16-36 Inv. Nom. Current	32-06 Absolute Encoder Clock Frequency	32-07 Absolute Encoder Clock Generation
14-26 Trip Delay at Inverter Fault	15-43 Software Version	16-37 Inv. Max. Current	32-08 Absolute Encoder Cable Length	32-09 Encoder Monitoring
14-28 Production Settings	15-44 Ordered Typecode String	16-38 SL Controller State	32-10 Rotational Direction	32-11 User Unit Denominator
14-3* Current Limit Ctrl.	15-45 Actual Typecode String	16-39 Control Card Temp.	18-** Data Readouts 2	32-12 User Unit Numerator
14-30 Current Lim Ctrl, Proportional Gain	15-46 Frequency Converter Ordering No	16-40 Logging Buffer Full	18-3* Analog Readouts	32-13 Enc.2 Control
14-31 Current Lim Ctrl, Integration Time	15-47 Power Card Ordering No	16-41 LCP Bottom Statusline	18-36 Analog Input X48/2 [mA]	32-14 Enc.2 node ID
14-32 Current Lim Ctrl, Filter Time	15-48 LCP ID No	16-49 Current Fault Source	18-38 Temp. Input X48/7	32-15 Enc.2 CAN guard
14-35 Stall Protection	15-49 SW ID Control Card	16-5* Ref. & Feeds.	18-39 Temp. Input X48/10	32-3* Encoder 1
14-4* Energy Optimizing	15-50 SW ID Power Card	16-50 External Reference	18-6* Inputs & Outputs 2	32-30 Incremental Signal Type
14-40 VT Level	15-51 Frequency Converter Serial Number	16-51 Pulse Reference	18-60 Digital Input 2	32-31 Incremental Resolution
14-41 AEO Minimum Magnetization	15-53 Power Card Serial Number	16-52 Feedback [Unit]	18-90 PID Readouts	32-32 Absolute Resolution
14-42 Minimum AEO Frequency	15-59 CSIW Filename	16-53 Digi Pot Reference	18-90 Process PID Error	32-33 Absolute Resolution
14-43 Motor Cos-Phi	15-6* Option Ident	16-57 Feedback [RPM]	18-91 Process PID Output	32-35 Absolute Encoder Data Length
14-5* Environment	15-60 Option Mounted	16-6* Inputs & Outputs	18-92 Process PID Clamped Output	
14-50 RFI Filter	15-61 Option SW Version	16-60 Digital Input		
14-51 DC Link Compensation	15-62 Option Ordering No	16-61 Terminal 53 Switch Setting		
14-52 Fan Control	15-63 Option Serial No	16-62 Analog input 53		
14-53 Fan Monitor	15-70 Option in Slot A	16-63 Terminal 54 Switch Setting		
14-55 Output Filter	15-71 Slot A Option SW Version	16-64 Analog Input 54		
	15-72 Option in Slot B	16-65 Analog Output 42 [mA]		

32-36 Absolute Encoder Clock Frequency	33-19 Master Marker Type	33-91 X62 MCO CAN baud rate	35-15 Term. X48/4 Temp. Monitor
32-37 Absolute Encoder Clock Generation	33-20 Slave Marker Type	33-94 X60 MCO RS485 serial termination	35-16 Term. X48/4 Low Temp. Limit
32-38 Absolute Encoder Cable Length	33-21 Master Marker, Tolerance Window	33-95 X60 MCO RS485 serial baud rate	35-17 Term. X48/4 High Temp. Limit
32-39 Encoder Monitoring	33-22 Slave Marker, Tolerance Window	34-0* MCO Data Readouts	35-2* Temp. Input X48/7
32-40 Encoder Termination	33-23 Start Behavior for Marker Sync	34-0* PCD Write Par.	35-24 Term. X48/7 Filter Time Constant
32-43 Enc.1 Control	33-24 Marker Number for Fault	34-01 PCD 1 Write to MCO	35-25 Term. X48/7 Temp. Monitor
32-44 Enc.1 node ID	33-25 Marker Number for Ready	34-02 PCD 2 Write to MCO	35-26 Term. X48/7 Low Temp. Limit
32-45 Enc.1 CAN guard	33-26 Velocity Filter	34-03 PCD 3 Write to MCO	35-27 Term. X48/7 High Temp. Limit
32-5* Feedback Source	33-27 Offset Filter Time	34-04 PCD 4 Write to MCO	35-3* Temp. Input X48/10
32-50 Source Slave	33-28 Marker Filter Configuration	34-05 PCD 5 Write to MCO	35-34 Term. X48/10 Filter Time Constant
32-51 MCO 302 Last Will	33-29 Filter Time for Marker Filter	34-06 PCD 6 Write to MCO	35-35 Term. X48/10 Temp. Monitor
32-52 Source Master	33-30 Maximum Marker Correction	34-07 PCD 7 Write to MCO	35-36 Term. X48/10 Low Temp. Limit
32-6* PID Controller	33-31 Synchronization Type	34-08 PCD 8 Write to MCO	35-37 Term. X48/10 High Temp. Limit
32-60 Proportional factor	33-32 Feed Forward Velocity Adaptation	34-09 PCD 9 Write to MCO	35-4* Analog Input X48/2
32-61 Derivative factor	33-33 Velocity Filter Window	34-10 PCD 10 Write to MCO	35-42 Term. X48/2 Low Current
32-62 Integral factor	33-34 Slave Marker filter time	34-2* PCD Read Par.	35-43 Term. X48/2 High Current
32-63 Limit Value for Integral Sum	33-4* Limit Handling	34-21 PCD 1 Read from MCO	35-44 Term. X48/2 Low Ref./Feedb. Value
32-64 PID Bandwidth	33-40 Behavior at End Limit Switch	34-22 PCD 2 Read from MCO	35-45 Term. X48/2 High Ref./Feedb. Value
32-65 Velocity Feed-Forward	33-41 Negative Software End Limit	34-23 PCD 3 Read from MCO	35-46 Term. X48/2 Filter Time Constant
32-66 Acceleration Feed-Forward	33-42 Positive Software End Limit	34-24 PCD 4 Read from MCO	
32-67 Max. Tolerated Position Error	33-43 Negative Software End Limit Active	34-25 PCD 5 Read from MCO	
32-68 Reverse Behavior for Slave	33-44 Positive Software End Limit Active	34-26 PCD 6 Read from MCO	
32-69 Sampling Time for PID Control	33-45 Time in Target Window	34-27 PCD 7 Read from MCO	
32-70 Scan Time for Profile Generator	33-46 Target Window Limit/Value	34-28 PCD 8 Read from MCO	
32-71 Size of the Control Window (Activation)	33-47 Size of Target Window	34-29 PCD 9 Read from MCO	
	33-5* I/O Configuration	34-30 PCD 10 Read from MCO	
32-72 Size of the Control Window (Deactiv.)	33-50 Terminal X57/1 Digital Input	34-4* Inputs & Outputs	
32-73 Integral limit filter time	33-51 Terminal X57/2 Digital Input	34-40 Digital Inputs	
32-74 Position error filter time	33-52 Terminal X57/3 Digital Input	34-41 Digital Outputs	
32-8* Velocity & Accel.	33-53 Terminal X57/4 Digital Input	34-5* Process Data	
32-80 Maximum Velocity (Encoder)	33-54 Terminal X57/5 Digital Input	34-50 Actual Position	
32-81 Shortest Ramp	33-55 Terminal X57/6 Digital Input	34-51 Commanded Position	
32-82 Ramp Type	33-56 Terminal X57/7 Digital Input	34-52 Actual Master Position	
32-83 Velocity Resolution	33-57 Terminal X57/8 Digital Input	34-53 Slave Index Position	
32-84 Default Velocity	33-58 Terminal X57/9 Digital Input	34-54 Master Index Position	
32-85 Default Acceleration	33-59 Terminal X57/10 Digital Input	34-55 Curve Position	
32-86 Acc. up for limited jerk	33-60 Terminal X59/1 and X59/2 Mode	34-56 Track Error	
32-87 Acc. down for limited jerk	33-61 Terminal X59/1 Digital Input	34-57 Synchronizing Error	
32-88 Dec. up for limited jerk	33-62 Terminal X59/2 Digital Input	34-58 Actual Velocity	
32-89 Dec. down for limited jerk	33-63 Terminal X59/1 Digital Output	34-59 Actual Master Velocity	
32-9* Development	33-64 Terminal X59/2 Digital Output	34-60 Synchronizing Status	
32-90 Debug Source	33-65 Terminal X59/3 Digital Output	34-61 Axis Status	
33-0* MCO Adv. Settings	33-66 Terminal X59/4 Digital Output	34-62 Program Status	
33-0* Home Motion	33-67 Terminal X59/5 Digital Output	34-64 MCO 302 Status	
33-00 Force HOME	33-68 Terminal X59/6 Digital Output	34-65 MCO 302 Control	
33-01 Zero Point Offset from Home Pos.	33-69 Terminal X59/7 Digital Output	34-7* Diagnosis readouts	
33-02 Ramp for Home Motion	33-70 Terminal X59/8 Digital Output	34-70 MCO Alarm Word 1	
33-03 Velocity of Home Motion	33-8* Global Parameters	34-71 MCO Alarm Word 2	
33-04 Behavior during Home Motion	33-80 Activated Program Number	35-0* Sensor Input Option	
33-1* Synchronization	33-81 Power-up State	35-0* Temp. Input Mode	
33-10 Sync Factor Master	33-82 Drive Status Monitoring	35-00 Term. X48/4 Temp. Unit	
33-11 Sync Factor Slave	33-83 Behavior after Error	35-01 Term. X48/4 Input Type	
33-12 Position Offset for Synchronization	33-84 Behavior after Esc.	35-02 Term. X48/7 Temp. Unit	
33-13 Accuracy Window for Position Sync.	33-85 MCO Supplied by External 24VDC	35-03 Term. X48/7 Input Type	
33-14 Relative Slave Velocity Limit	33-86 Terminal at alarm	35-04 Term. X48/10 Temp. Unit	
33-15 Marker Number for Master	33-87 Terminal state at alarm	35-05 Term. X48/10 Input Type	
33-16 Marker Number for Slave	33-88 Status word at alarm	35-1* Temp. Input X48/4	
33-17 Master Marker Distance	33-9* MCO Port Settings	35-06 Temperature Sensor Alarm Function	
33-18 Slave Marker Distance	33-90 X62 MCO CAN node ID	35-14 Term. X48/4 Filter Time Constant	

5.6 Remote Programming with MCT 10 Set-up Software

Danfoss has a software program available for developing, storing, and transferring Adjustable frequency drive programming. The MCT 10 Set-up Software allows the user to connect a PC to the Adjustable frequency drive and perform live programming rather than using the LCP. Also, all Adjustable frequency drive programming can be done off-line and simply downloaded into Adjustable frequency drive. Or the entire Adjustable frequency drive profile can be loaded onto the PC for backup storage or analysis.

The USB connector or RS-485 terminal are available for connecting to the Adjustable frequency drive.

MCT 10 Set-up Software is available for free download at www.VLT-software.com. A CD is also available by requesting part number 130B1000. A user's manual provides detailed instructions.

6 Application Set-Up Examples

6.1 Introduction

NOTE!

A jumper wire may be required between terminal 12 (or 13) and terminal 27 for the Adjustable frequency drive to operate when using factory default programming values. See 2.4.1.1 Jumper Terminals 12 and 27 for details.

The examples in this section are intended as a quick reference for common applications.

- Parameter settings are the regional default values unless otherwise indicated (selected in 0-03 Regional Settings)
- Parameters associated with the terminals and their settings are shown next to the drawings.
- Where switch settings for analog terminals A53 or A54 are required, these are also shown.

FC		Parameters		
		Function	Setting	
+24 V	12	130BB930.10	1-29 Automatic Motor Adaptation (AMA)	
+24 V	13			[1] Enable complete
D IN	18			AMA
D IN	19			
COM	20			
D IN	27			5-12 Terminal 27 Digital Input
D IN	29			[0] No operation
D IN	32			
D IN	33			
D IN	37			
+10 V	50	* = Default Value		
A IN	53	Notes/comments: Parameter group 1-2* must be set according to motor		
A IN	54			
COM	55			
A OUT	42			
COM	39			

6.2 Application Examples

FC		Parameters		
		Function	Setting	
+24 V	12	130BB929.10	1-29 Automatic Motor Adaptation (AMA)	
+24 V	13			[1] Enable complete
D IN	18			AMA
D IN	19			
COM	20			
D IN	27			5-12 Terminal 27 Digital Input
D IN	29			[2]* Coast inverse
D IN	32			
D IN	33			
D IN	37			
+10 V	50	* = Default Value		
A IN	53	Notes/comments: Parameter group 1-2* must be set according to motor		
A IN	54			
COM	55			
A OUT	42			
COM	39			

Table 6.1 AMA with T27 Connected

Table 6.2 AMA without T27 Connected

FC		Parameters		
		Function	Setting	
+24 V	12	130BB926.10	6-10 Terminal 53 Low Voltage	
+24 V	13			0.07V*
D IN	18			6-11 Terminal 53 High Voltage
D IN	19			10V*
COM	20			
D IN	27			6-14 Terminal 53 Low Ref./Feedb. Value
D IN	29			0 RPM
D IN	32			6-15 Terminal 53 High Ref./Feedb. Value
D IN	33			1500 RPM
D IN	37			
+10 V	50	* = Default Value		
A IN	53	Notes/comments:		
A IN	54			
COM	55			
A OUT	42			
COM	39			

Table 6.3 Analog Speed Reference (Voltage)

6

FC		Parameters	
		Function	Setting
+24 V	12	6-12 Terminal 53	4mA*
+24 V	13	Low Current	
D IN	18	6-13 Terminal 53	20mA*
D IN	19	High Current	
COM	20	6-14 Terminal 53	0 RPM
D IN	27	Low Ref./Feedb. Value	
D IN	29	6-15 Terminal 53	1500 RPM
D IN	32	High Ref./Feedb. Value	
D IN	33	* = Default Value	
D IN	37	Notes/comments:	
+10 V	50		
A IN	53		
A IN	54		
COM	55		
A OUT	42		
COM	39		

Table 6.4 Analog Speed Reference (Current)

FC		Parameters	
		Function	Setting
+24 V	12	5-10 Terminal 18	[8] Start*
+24 V	13	Digital Input	
D IN	18	5-12 Terminal 27	[0] No operation
D IN	19	Digital Input	
COM	20	5-19 Terminal 37	[1] Safe Stop Alarm
D IN	27	Safe Stop	
D IN	29	* = Default Value	
D IN	32	Notes/comments:	
D IN	33	If 5-12 Terminal 27 Digital Input is set to [0] No operation, a jumper wire to terminal 27 is not needed.	
D IN	37		
+10	50		
A IN	53		
A IN	54		
COM	55		
A OUT	42		
COM	39		

Table 6.5 Start/Stop Command with Safe Stop

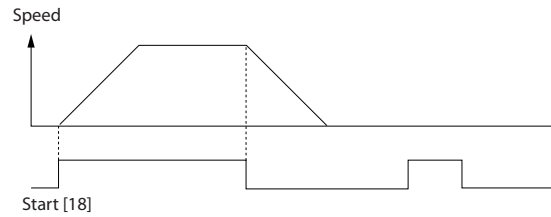

130BB805.10

FC		Parameters	
		Function	Setting
+24 V	12	5-10 Terminal 18	[9] Latched Start
+24 V	13	Digital Input	
D IN	18	5-12 Terminal 27	[6] Stop Inverse
D IN	19	Digital Input	
COM	20	* = Default Value	
D IN	27	Notes/comments:	
D IN	29	If 5-12 Terminal 27 Digital Input is set to [0] No operation, a jumper wire to terminal 27 is not needed.	
D IN	32		
D IN	33		
D IN	37		
+10 V	50		
A IN	53		
A IN	54		
COM	55		
A OUT	42		
COM	39		

Table 6.6 Pulse Start/Stop

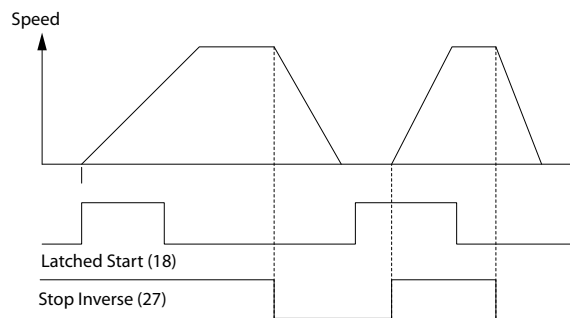

130BB806.10

		Parameters	
		Function	Setting
		5-10 Terminal 18 <i>Digital Input</i>	[8] Start
		5-11 Terminal 19 <i>Digital Input</i>	[10] Reversing*
		5-12 Terminal 27 <i>Digital Input</i>	[0] No operation
		5-14 Terminal 32 <i>Digital Input</i>	[16] Preset ref bit 0
		5-15 Terminal 33 <i>Digital Input</i>	[17] Preset ref bit 1
		3-10 Preset Reference	
		Preset ref. 0	25%
		Preset ref. 1	50%
		Preset ref. 2	75%
		Preset ref. 3	100%
		* = Default Value	
		Notes/comments:	

Table 6.7 Start/Stop with Reversing and Four Preset Speeds

		Parameters	
		Function	Setting
		5-11 Terminal 19 <i>Digital Input</i>	[1] Reset
		* = Default Value	
		Notes/comments:	

Table 6.8 External Alarm Reset

		Parameters	
		Function	Setting
		6-10 Terminal 53 <i>Low Voltage</i>	0.07V*
		6-11 Terminal 53 <i>High Voltage</i>	10V*
		6-14 Terminal 53 <i>Low Ref./Feedb. Value</i>	0 RPM
		6-15 Terminal 53 <i>High Ref./Feedb. Value</i>	1500 RPM
		* = Default Value	
		Notes/comments:	

Table 6.9 Speed Reference (using a manual potentiometer)

		Parameters	
		Function	Setting
		5-10 Terminal 18 <i>Digital Input</i>	[8] Start*
		5-12 Terminal 27 <i>Digital Input</i>	[19] Freeze Reference
		5-13 Terminal 29 <i>Digital Input</i>	[21] Speed Up
		5-14 Terminal 32 <i>Digital Input</i>	[22] Speed down
		* = Default Value	
		Notes/comments:	

Table 6.10 Speed Up/Down

6

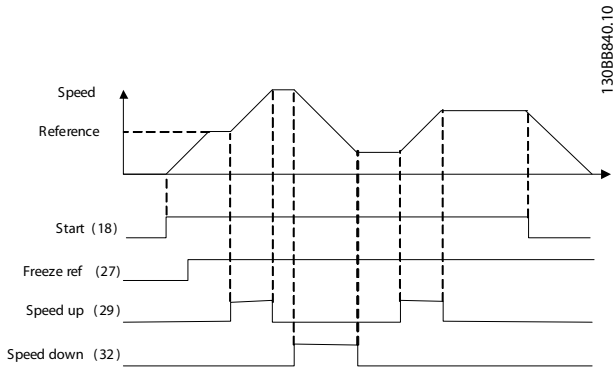

Parameters	
Function	Setting
FC	
+24 V 12	
+24 V 13	
D IN 18	
D IN 19	
COM 20	
D IN 27	
D IN 29	
D IN 32	
D IN 33	
D IN 37	
* = Default Value	
Notes/comments:	
Select protocol, address and baud rate in the above mentioned parameters.	

+10 V 50	
A IN 53	
A IN 54	
COM 55	
A OUT 42	
COM 39	
R1 01	
02	
03	
R2 04	
05	
06	
61	
68	
69	
RS-485	

Table 6.11 RS-485 Network Connection

Parameters	
Function	Setting
FC	
+24 V 12	
+24 V 13	
D IN 18	
D IN 19	
COM 20	
D IN 27	
D IN 29	
D IN 32	
D IN 33	
D IN 37	
+10 V 50	
A IN 53	
A IN 54	
COM 55	
A OUT 42	
COM 39	
* = Default Value	
Notes/comments:	
If only a warning is desired, 1-90 Motor Thermal Protection should be set to [1] Thermistor warning.	

Table 6.12 Motor Thermistor

CAUTION

Thermistors must use reinforced or double insulation to meet PELV insulation requirements.

FC		Parameters		
		Function	Setting	
+24 V	12	130BB839.10	4-30 Motor Feedback Loss Function	[1] Warning
+24 V	13		4-31 Motor Feedback Speed Error	100 RPM
D IN	18		4-32 Motor Feedback Loss Timeout	5 sec
D IN	19		7-00 Speed PID Feedback Source	[2] MCB 102
COM	20		17-11 Resolution (PPR)	1024*
D IN	27		13-00 SL Controller Mode	[1] On
D IN	29		13-01 Start Event	[19] Warning
D IN	32		13-02 Stop Event	[44] Reset key
D IN	33		13-10 Comparator Operand	[21] Warning no.
D IN	37		13-11 Comparator Operator	[1] ≈*
+10 V	50		13-12 Comparator Value	90
A IN	53		13-51 SL Controller Event	[22] Comparator 0
A IN	54		13-52 SL Controller Action	[32] Set digital out A low
COM	55	5-40 Function Relay	[80] SL digital output A	
A OUT	42	* = Default Value		
COM	39	Notes/comments: If the limit in the feedback monitor is exceeded, Warning 90 will be issued. The SLC monitors Warning 90 and if Warning 90 becomes TRUE, then Relay 1 is triggered. External equipment may then indicate that service may be required. If the feedback error goes below the limit again within 5 sec., then the drive continues and the warning disappears. But Relay 1 will still be triggered until [Reset] on the LCP.		

FC		Parameters		
		Function	Setting	
+24 V	12	130BB841.10	5-40 Function Relay	[32] Mech. brake ctrl.
+24 V	13		5-10 Terminal 18 Digital Input	[8] Start*
D IN	18		5-11 Terminal 19 Digital Input	[11] Start reversing
D IN	19		1-71 Start Delay	0.2
COM	20		1-72 Start Function	[5] VVC+/FLUX Clockwise
D IN	27		1-76 Start Current	Im,n
D IN	29		2-20 Release Brake Current	App. dependent
D IN	32		2-21 Activate Brake Speed [RPM]	Half of nominal slip of the motor
D IN	33		* = Default Value	
D IN	37		Notes/comments:	
+10 V	50			
A IN	53			
A IN	54			
COM	55			
A OUT	42			
COM	39			

Table 6.14 Mechanical Brake Control

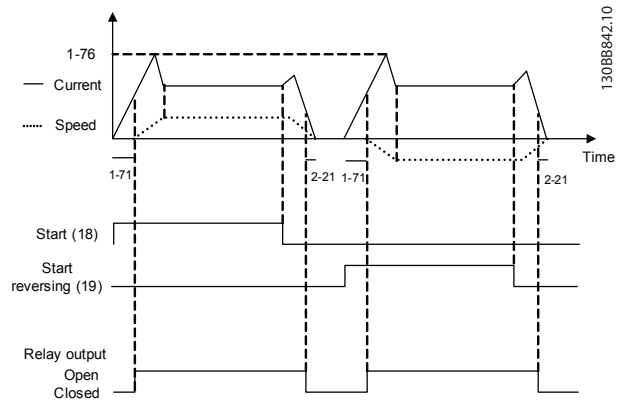

Table 6.13 Using SLC to Set a Relay

7 Status Messages

7.1 Status Display

When the Adjustable frequency drive is in status mode, status messages are generated automatically from within the Adjustable frequency drive and appear in the bottom line of the display (see *Figure 7.1.*)

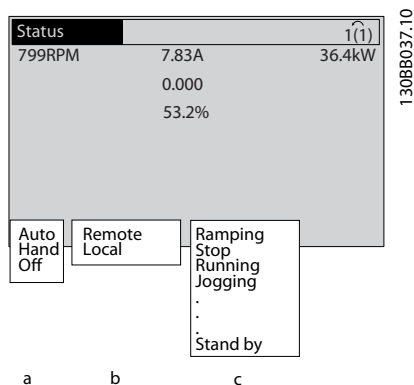

Figure 7.1 Status Display

- The first word on the status line indicates where the stop/start command originates.
- The second word on the status line indicates where the speed control originates.
- The last part of the status line gives the present Adjustable frequency drive status. These show the operational mode the Adjustable frequency drive is in.

NOTE!

In auto/remote mode, the Adjustable frequency drive requires external commands to execute functions.

7.2 Status Message Definitions Table

The next three tables define the meaning of the status message display words.

	Operation mode
Off	The adjustable frequency drive does not react to any control signal until [Auto On] or [Hand On] is pressed.
Auto On	The adjustable frequency drive is controlled from the control terminals and/or the serial communication.
Hand On	The adjustable frequency drive can be controlled by the navigation keys on the LCP. Stop commands, reset, reversing, DC brake, and other signals applied to the control terminals can override local control.

	Reference site
Remote	The speed reference is given from external signals, serial communication, or internal preset references.
Local	The adjustable frequency drive uses [Hand On] control or reference values from the LCP.

	Operation status
AC Brake	AC Brake was selected in 2-10 Brake Function. The AC brake overmagnetizes the motor to achieve a controlled slow-down.
AMA finish OK	Automatic motor adaptation (AMA) was carried out successfully.
AMA ready	AMA is ready to start. Press [Hand On] to start.
AMA running	AMA process is in progress.
Braking	The brake chopper is in operation. Generative energy is absorbed by the brake resistor.
Braking max.	The brake chopper is in operation. The power limit for the brake resistor defined in 2-12 Brake Power Limit (kW) is reached.
Coast	<ul style="list-style-type: none"> Coast inverse was selected as a function for a digital input (parameter group 5-1*). The corresponding terminal is not connected. Coast activated by serial communication

	Operation status
Ctrl. Ramp-down	Control Ramp-down was selected in <i>14-10 Mains Failure</i> . <ul style="list-style-type: none"> The AC line voltage is below the value set in <i>14-11 Mains Voltage at Mains Fault</i> at line power fault The adjustable frequency drive ramps down the motor using a controlled ramp-down.
Current High	The adjustable frequency drive output current is above the limit set in <i>4-51 Warning Current High</i> .
Current Low	The adjustable frequency drive output current is below the limit set in <i>4-52 Warning Speed Low</i>
DC Hold	DC hold is selected in <i>1-80 Function at Stop</i> and a stop command is active. The motor is held by a DC current set in <i>2-00 DC Hold/ Preheat Current</i> .
DC Stop	The motor is held with a DC current (<i>2-01 DC Brake Current</i>) for a specified time (<i>2-02 DC Braking Time</i>). <ul style="list-style-type: none"> DC Brake is activated in <i>2-03 DC Brake Cut-in Speed [RPM]</i> and a Stop command is active. DC Brake (inverse) is selected as a function for a digital input (parameter group 5-1*). The corresponding terminal is not active. The DC Brake is activated via serial communication.
Feedback high	The sum of all active feedbacks is above the feedback limit set in <i>4-57 Warning Feedback High</i> .
Feedback low	The sum of all active feedbacks is below the feedback limit set in <i>4-56 Warning Feedback Low</i> .
Freeze output	The remote reference is active which holds the present speed. <ul style="list-style-type: none"> Freeze output was selected as a function for a digital input (Group 5-1*). The corresponding terminal is active. Speed control is only possible via the terminal functions speed up and slow. Hold ramp is activated via serial communication.
Freeze output request	A freeze output command has been given, but the motor will remain stopped until a run permissive signal is received.

	Operation status
Freeze ref.	Freeze Reference was chosen as a function for a digital input (parameter group 5-1*). The corresponding terminal is active. The adjustable frequency drive saves the actual reference. Changing the reference is now only possible via terminal functions speed up and slow.
Jog request	A jog command has been given, but the motor will be stopped until a run permissive signal is received via a digital input.
Jogging	The motor is running as programmed in <i>3-19 Jog Speed [RPM]</i> . <ul style="list-style-type: none"> Jog was selected as function for a digital input (parameter group 5-1*). The corresponding terminal (e.g., Terminal 29) is active. The Jog function is activated via the serial communication. The Jog function was selected as a reaction for a monitoring function (e.g., No signal). The monitoring function is active.
Motor check	In <i>1-80 Function at Stop, Motor Check</i> was selected. A stop command is active. To ensure that a motor is connected to the adjustable frequency drive, a permanent test current is applied to the motor.
OVC control	<i>Overvoltage</i> control was activated in <i>2-17 Overvoltage Control</i> . The connected motor is supplying the adjustable frequency drive with generative energy. The overvoltage control adjusts the V/Hz ratio to run the motor in controlled mode and to prevent the adjustable frequency drive from tripping.
PowerUnit Off	(For adjustable frequency drives with an external 24V power supply installed only.) Line power supply to the adjustable frequency drive is removed, but the control card is supplied by the external 24V.
Protection md	Protection mode is active. The unit has detected a critical status (an overcurrent or overvoltage). <ul style="list-style-type: none"> To avoid tripping, switching frequency is reduced to 4kHz. If possible, protection mode ends after approximately 10sec. Protection mode can be restricted in <i>14-26 Trip Delay at Inverter Fault</i>

	Operation status
QStop	The motor is decelerating using <i>3-81 Quick Stop Ramp Time</i> . <ul style="list-style-type: none"> Quick stop inverse was chosen as a function for a digital input (parameter group 5-1*). The corresponding terminal is not active. The quick stop function was activated via serial communication.
Ramping	The motor is accelerating/decelerating using the active ramp-up/down. The reference, a limit value or a standstill is not yet reached.
Ref. high	The sum of all active references is above the reference limit set in <i>4-55 Warning Reference High</i> .
Ref. low	The sum of all active references is below the reference limit set in <i>4-54 Warning Reference Low</i> .
Run on ref.	The adjustable frequency drive is running in the reference range. The feedback value matches the setpoint value.
Run request	A start command has been given, but the motor is stopped until a run permissive signal is received via digital input.
Running	The motor is driven by the adjustable frequency drive.
Speed high	Motor speed is above the value set in <i>4-53 Warning Speed High</i> .
Speed low	Motor speed is below the value set in <i>4-52 Warning Speed Low</i> .
Standby	In Auto On mode, the adjustable frequency drive will start the motor with a start signal from a digital input or serial communication.
Start delay	In <i>1-71 Start Delay</i> , a delay starting time was set. A start command is activated and the motor will start after the start delay time expires.
Start fwd/rev	Start forward and start reverse were selected as functions for two different digital inputs (parameter group 5-1*). The motor will start in forward or reverse depending on which corresponding terminal is activated.
Stop	The adjustable frequency drive has received a stop command from the LCP, digital input or serial communication.
Trip	An alarm occurred and the motor is stopped. Once the cause of the alarm is cleared, the adjustable frequency drive can be reset manually by pressing [Reset] or remotely by control terminals or serial communication.

	Operation status
Trip lock	An alarm occurred and the motor is stopped. Once the cause of the alarm is cleared, power must be cycled to the adjustable frequency drive. The adjustable frequency drive can then be reset manually by pressing [Reset] or remotely by control terminals or serial communication.

8 Warnings and Alarms

8.1 System Monitoring

The Adjustable frequency drive monitors the condition of its input power, output, and motor factors as well as other system performance indicators. A warning or alarm may not necessarily indicate a problem internal to the Adjustable frequency drive itself. In many cases it indicates failure conditions from input voltage, motor load or temperature, external signals, or other areas monitored by the adjustable frequency drive's internal logic. Be sure to investigate those areas exterior to the Adjustable frequency drive as indicated in the alarm or warning.

8.2 Warning and Alarm Types

Warnings

A warning is issued when an alarm condition is impending or when an abnormal operating condition is present and may result in the Adjustable frequency drive issuing an alarm. A warning clears by itself when the abnormal condition is removed.

Alarms

Trip

An alarm is issued when the Adjustable frequency drive is tripped, that is, the Adjustable frequency drive suspends operation to prevent Adjustable frequency drive or system damage. The motor will coast to a stop. The Adjustable frequency drive logic will continue to operate and monitor the Adjustable frequency drive status. After the fault condition is remedied, the Adjustable frequency drive can be reset. It will then be ready to start operation again.

A trip can be reset in any of 4 ways:

- Press [RESET] on the LCP
- Digital reset input command
- Serial communication reset input command
- Auto reset

Trip lock

An alarm that causes the Adjustable frequency drive to trip-lock requires that input power be cycled. The motor will coast to a stop. The Adjustable frequency drive logic will continue to operate and monitor the Adjustable frequency drive status. Remove input power to the Adjustable frequency drive and correct the cause of the fault, then restore power. This action puts the Adjustable frequency drive into a trip condition as described above and may be reset in any of those four ways.

8.3 Warning and Alarm Displays

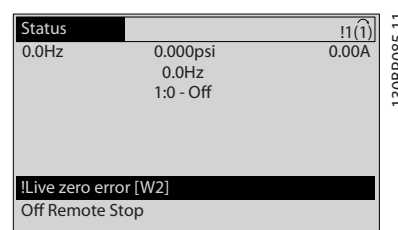

An alarm or trip lock alarm will flash on display along with the alarm number.

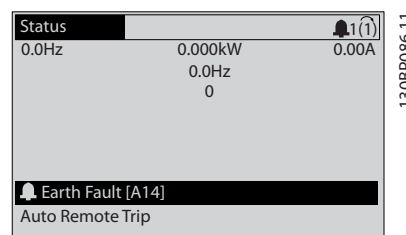

In addition to the text and alarm code on the Adjustable frequency drive display, the status indicator lights operate.

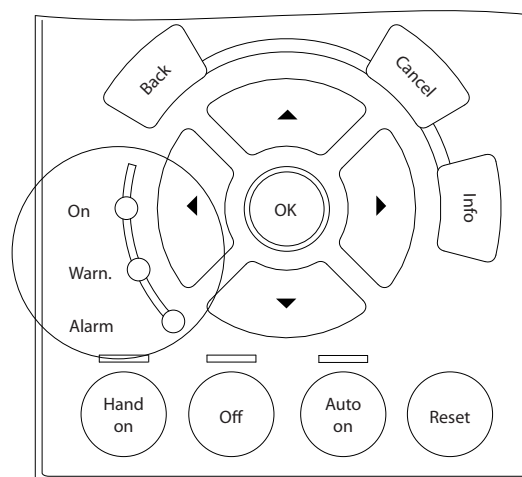

	Warn. LED	Alarm LED
Warning	ON	OFF
Alarm	OFF	ON (Flashing)
Trip Lock	ON	ON (Flashing)

8.4 Warning and Alarm Definitions

defines whether a warning is issued prior to an alarm, and whether the alarm trips the unit or trip locks the unit.

No.	Description	Warning	Alarm/Trip	Alarm/Trip Lock	Parameter Reference
1	10V low	X			
2	Live zero error	(X)	(X)		6-01 Live Zero Timeout Function
3	No motor	(X)			1-80 Function at Stop
4	Mains phase loss	(X)	(X)	(X)	14-12 Function at Mains Imbalance
5	DC link voltage high	X			
6	DC link voltage low	X			
7	DC over-voltage	X	X		
8	DC under voltage	X	X		
9	Inverter overloaded	X	X		
10	Motor ETR over temperature	(X)	(X)		1-90 Motor Thermal Protection
11	Motor thermistor over temperature	(X)	(X)		1-90 Motor Thermal Protection
12	Torque limit	X	X		
13	Overcurrent	X	X	X	
14	Ground Fault	X	X	X	
15	Hardware mismatch		X	X	
16	Short Circuit		X	X	
17	Control word time-out	(X)	(X)		8-04 Control Word Timeout Function
20	Temp. Input Error				
21	Param Error				
22	Hoist Mech. Brake	(X)	(X)		Parameter group 2-2*
23	Internal Fans	X			
24	External Fans	X			
25	Brake resistor short-circuited	X			
26	Brake resistor power limit	(X)	(X)		2-13 Brake Power Monitoring
27	Brake chopper short-circuited	X	X		
28	Brake check	(X)	(X)		2-15 Brake Check
29	Heatsink temp	X	X	X	
30	Motor phase U missing	(X)	(X)	(X)	4-58 Missing Motor Phase Function
31	Motor phase V missing	(X)	(X)	(X)	4-58 Missing Motor Phase Function
32	Motor phase W missing	(X)	(X)	(X)	4-58 Missing Motor Phase Function
33	Inrush Fault		X	X	
34	Fieldbus fault	X	X		
35	Option Fault				
36	Line failure	X	X		
37	Phase imbalance		X		
38	Internal Fault		X	X	

Warnings and Alarms **VLT® Automation Drive Instruction Manual**

No.	Description	Warning	Alarm/Trip	Alarm/Trip Lock	Parameter Reference
39	Heatsink sensor		X	X	
40	Overload T27	(X)			5-00 Digital I/O Mode, 5-01 Terminal 27 Mode
41	Overload of Digital Output Terminal 29	(X)			5-00 Digital I/O Mode, 5-02 Terminal 29 Mode
42	Ovrlld X30/6-7	(X)			
43	Ext. Supply (option)				
45	Earth Fault 2	X	X	X	
46	Pwr. card supply		X	X	
47	24 V supply low	X	X	X	
48	1.8 V supply low		X	X	
49	Speed limit	X			
50	AMA calibration failed		X		
51	AMA U_{nom} , I_{nom}		X		
52	AMA low I_{nom}		X		
53	AMA motor too big		X		
54	AMA motor too small		X		
55	AMA parameter out of range		X		
56	AMA interrupted by user		X		
57	AMA timeout		X		
58	AMA internal fault	X	X		
59	Current limit	X			
61	Tracking error	(X)	(X)		4-30 Motor Feedback Loss Function
62	Output Frequency at Maximum Limit	X			
63	Mechanical Brake Low		(X)		2-20 Release Brake Current
64	Voltage Limit	X			
65	Control Board Over-temperature	X	X	X	
66	Heat sink Temperature Low	X			
67	Option Configuration has Changed		X		
68	Safe Stop	(X)	(X) ¹⁾		5-19 Terminal 37 Safe Stop
69	Pwr. Card Temp		X	X	
70	Illegal FC config			X	
71	PTC 1 Safe Stop				
72	Dangerous failure				
73	Safe Stop Auto Restart	(X)	(X)		5-19 Terminal 37 Safe Stop
74	PTC Thermistor			X	
75	Illegal Profile Sel.		X		
76	Power Unit Setup	X			
77	Reduced power mode	X			14-59 Actual Number of Inverter Units
78	Tracking Error	(X)	(X)		4-34 Tracking Error Function
79	Illegal PS config		X	X	
80	Drive Initialized to Default Value		X		
81	CSIV corrupt		X		

No.	Description	Warning	Alarm/Trip	Alarm/Trip Lock	Parameter Reference
82	CSIV parameter error		X		
83	Illegal Option Combination			X	
84	No Safety Option		X		
88	Option Detection			X	
89	Mechanical Brake Sliding	X			
90	Feedback Monitor	(X)	(X)		17-61 Feedback Signal Monitoring
91	Analog input 54 wrong settings			X	S202
163	ATEX ETR cur.lim.warning	X			
164	ATEX ETR cur.lim.alarm		X		
165	ATEX ETR freq.lim.warning	X			
166	ATEX ETR freq.lim.alarm		X		
243	Brake IGBT	X	X	X	
244	Heatsink temp	X	X	X	
245	Heatsink sensor		X	X	
246	Pwr.card supply			X	
247	Pwr.card temp		X	X	
248	Illegal PS config			X	
249	Rect. low temp.	X			
250	New spare parts			X	
251	New Type Code		X	X	

Table 8.1 Alarm/Warning Code List

(X) Dependent on parameter

1) Cannot be Auto reset via 14-20 Reset Mode

8.4.1 Fault Messages

The warning/alarm information below defines the warning/alarm condition, provides the probable cause for the condition, and details a remedy or troubleshooting procedure.

WARNING 1, 10V low

The control card voltage is below 10V from terminal 50. Remove some of the load from terminal 50, as the 10V supply is overloaded. Max. 15mA or minimum 590 Ω.

This condition can be caused by a short in a connected potentiometer or improper wiring of the potentiometer.

Troubleshooting

Remove the wiring from terminal 50. If the warning clears, the problem is with the customer wiring. If the warning does not clear, replace the control card.

WARNING/ALARM 2, Live zero error

This warning or alarm will only appear if programmed by the user in 6-01 Live Zero Timeout Function. The signal on one of the analog inputs is less than 50% of the minimum value programmed for that input. This condition can be caused by broken wiring or faulty device sending the signal.

Troubleshooting

Check connections on all the analog input terminals. Control card terminals 53 and 54 for signals, terminal 55 common. MCB 101 terminals 11 and 12 for signals, terminal 10 common. MCB 109 terminals 1, 3, 5 for signals, terminals 2, 4, 6 common).

Check that the Adjustable frequency drive programming and switch settings match the analog signal type.

Perform Input Terminal Signal Test.

WARNING/ALARM 3, No motor

No motor has been connected to the output of the Adjustable frequency drive.

WARNING/ALARM 4, Mains phase loss

A phase is missing on the supply side, or the line voltage imbalance is too high. This message also appears for a fault in the input rectifier on the Adjustable frequency drive. Options are programmed at *14-12 Function at Mains Imbalance*.

Troubleshooting

Check the supply voltage and supply currents to the Adjustable frequency drive.

WARNING 5, DC link voltage high

The intermediate circuit voltage (DC) is higher than the high voltage warning limit. The limit is dependent on the Adjustable frequency drive voltage rating. The Adjustable frequency drive is still active.

WARNING 6, DC link voltage low

The intermediate circuit voltage (DC) is lower than the low voltage warning limit. The limit is dependent on the Adjustable frequency drive voltage rating. The Adjustable frequency drive is still active.

WARNING/ALARM 7, DC overvoltage

If the intermediate circuit voltage exceeds the limit, the Adjustable frequency drive trips after a time.

Troubleshooting

- Connect a brake resistor
- Extend the ramp time
- Change the ramp type
- Activate functions in *2-10 Brake Function*
- Increase *14-26 Trip Delay at Inverter Fault*

WARNING/ALARM 8, DC under voltage

If the intermediate circuit voltage (DC) drops below the undervoltage limit, the Adjustable frequency drive checks if a 24V DC backup supply is connected. If no 24V DC backup supply is connected, the Adjustable frequency drive trips after a fixed time delay. The time delay varies with unit size.

Troubleshooting

- Check that the supply voltage matches the Adjustable frequency drive voltage.
- Perform Input voltage test
- Perform soft charge and rectifier circuit test

WARNING/ALARM 9, Inverter overload

The Adjustable frequency drive is about to cut out because of an overload (too high current for too long). The counter for electronic, thermal inverter protection gives a warning at 98% and trips at 100%, while giving an alarm. The

Adjustable frequency drive *cannot* be reset until the counter is below 90%.

The fault is that the Adjustable frequency drive is overloaded by more than 100% for too long.

Troubleshooting

Compare the output current shown on the LCP with the Adjustable frequency drive rated current.

Compare the output current shown on the LCP with measured motor current.

Display the Thermal Drive Load on the LCP and monitor the value. When running above the Adjustable frequency drive continuous current rating, the counter should increase. When running below the Adjustable frequency drive continuous current rating, the counter should decrease.

See the derating section in the *Design Guide* for more details if a high switching frequency is required.

WARNING/ALARM 10, Motor overload temperature

According to the electronic thermal protection (ETR), the motor is too hot. Select whether the Adjustable frequency drive gives a warning or an alarm when the counter reaches 100% in *1-90 Motor Thermal Protection*. The fault occurs when the motor is overloaded by more than 100% for too long.

Troubleshooting

- Check for motor overheating.
- Check if the motor is mechanically overloaded.
- Check that the motor current set in *1-24 Motor Current* is correct.
- Ensure that Motor data in parameters 1-20 through 1-25 are set correctly.
- If an external fan is in use, check in *1-91 Motor External Fan* that it is selected.
- Running AMA in *1-29 Automatic Motor Adaptation (AMA)* may tune the Adjustable frequency drive to the motor more accurately and reduce thermal loading.

WARNING/ALARM 11, Motor thermistor over temp

The thermistor might be disconnected. Select whether the Adjustable frequency drive gives a warning or an alarm in *1-90 Motor Thermal Protection*.

Troubleshooting

- Check for motor overheating.
- Check if the motor is mechanically overloaded.
- When using terminal 53 or 54, check that the thermistor is connected correctly between either terminal 53 or 54 (analog voltage input) and

terminal 50 (+10V supply) and that the terminal switch for 53 or 54 is set for voltage. Check *1-93 Thermistor Source* selects terminal 53 or 54.

When using digital inputs 18 or 19, check that the thermistor is connected correctly between either terminal 18 or 19 (digital input PNP only) and terminal 50. Check *1-93 Thermistor Source* selects terminal 18 or 19.

WARNING/ALARM 12, Torque limit

The torque has exceeded the value in *4-16 Torque Limit Motor Mode* or the value in *4-17 Torque Limit Generator Mode*. *14-25 Trip Delay at Torque Limit* can change this from a warning only condition to a warning followed by an alarm.

Troubleshooting

If the motor torque limit is exceeded during ramp-up, extend the ramp-up time.

If the generator torque limit is exceeded during ramp-down, extend the ramp-down time.

If torque limit occurs while running, possibly increase the torque limit. Be sure the system can operate safely at a higher torque.

Check the application for excessive current draw on the motor.

WARNING/ALARM 13, Overcurrent

The inverter peak current limit (approx. 200% of the rated current) is exceeded. The warning lasts about 1.5 sec., then the Adjustable frequency drive trips and issues an alarm. This fault may be caused by shock loading or fast acceleration with high inertia loads. If extended mechanical brake control is selected, trip can be reset externally.

Troubleshooting

Remove power and check if the motor shaft can be turned.

Check that the motor size matches the Adjustable frequency drive.

Check parameters 1-20 through 1-25 for correct motor data.

ALARM 14, Ground fault

There is current from the output phases to ground, either in the cable between the Adjustable frequency drive and the motor or in the motor itself.

Troubleshooting

Remove power to the Adjustable frequency drive and repair the ground fault.

Check for ground faults in the motor by measuring the resistance to ground of the motor leads and the motor with a megohmmeter.

ALARM 15, Hardware mismatch

A fitted option is not operational with the present control board hardware or software.

Record the value of the following parameters and contact your Danfoss supplier:

15-40 FC Type

15-41 Power Section

15-42 Voltage

15-43 Software Version

15-45 Actual Typecode String

15-49 SW ID Control Card

15-50 SW ID Power Card

15-60 Option Mounted

15-61 Option SW Version

ALARM 16, Short circuit

There is a short circuit in the motor or motor wiring.

Remove power to the Adjustable frequency drive and repair the short circuit.

WARNING/ALARM 17, Control word timeout

There is no communication to the Adjustable frequency drive.

The warning will only be active when *8-04 Control Timeout Function* is NOT set to [0] OFF.

If *8-04 Control Timeout Function* is set to *Stop and Trip*, a warning appears and the Adjustable frequency drive ramps down until it stops then displays an alarm.

Troubleshooting

Check connections on the serial communication cable.

Increase *8-03 Control Timeout Time*

Check the operation of the communication equipment.

Verify proper installation based on EMC requirements.

WARNING/ALARM 20, Temp. input error

The temperature sensor is not connected.

WARNING/ALARM 21, Parameter error

The parameter is out of range. The parameter number is reported in the LCP. The affected parameter must be set to a valid value.

WARNING/ALARM 22, Hoist mechanical brake

Report value will show what kind it is. 0 = The torque ref. was not reached before timeout. 1 = There was no brake feedback before timeout.

WARNING 23, Internal Fans

The fan warning function checks if the fan is running. The fan warning can be disabled in *14-53 Fan Monitor*.

Troubleshooting

Check for proper fan operation.

Cycle power to the Adjustable frequency drive and make sure that the fan operates briefly at start-up.

Check the sensors on the heatsink and control card.

WARNING 24, External fan fault

The fan warning function checks if the fan is running. The fan warning can be disabled in *14-53 Fan Monitor*.

Troubleshooting

Check for proper fan operation.

Cycle power to the Adjustable frequency drive and make sure that the fan operates briefly at start-up.

Check the sensors on the heatsink and control card.

WARNING 25, Brake resistor short circuit

The brake resistor is monitored during operation. If a short circuit occurs, the brake function is disabled and the warning appears. The Adjustable frequency drive is still operational but without the brake function. Remove power to the Adjustable frequency drive and replace the brake resistor (see *2-15 Brake Check*).

WARNING/ALARM 26, Brake resistor power limit

The power transmitted to the brake resistor is calculated as a mean value over the last 120 seconds of run time. The calculation is based on the intermediate circuit voltage and the brake resistance value set in *2-16 AC Brake Max*.

Current. The warning is active when the dissipated braking is higher than 90% of the brake resistance power. If *Trip [2]* is selected in *2-13 Brake Power Monitoring*, the Adjustable frequency drive will trip when the dissipated braking energy reaches 100%.

WARNING/ALARM 27, Brake chopper fault

The brake transistor is monitored during operation and if a short circuit occurs, the brake function is disabled and a warning is issued. The Adjustable frequency drive is still operational but, since the brake transistor has short-circuited, substantial power is transmitted to the brake resistor, even if it is inactive.

Remove power to the Adjustable frequency drive and remove the brake resistor.

WARNING/ALARM 28, Brake check

The brake resistor is not connected or not working. Check *2-15 Brake Check*.

ALARM 29, Heatsink temp

The maximum temperature of the heatsink has been exceeded. The temperature fault will not reset until the temperature falls below the reset heatsink temperature.

The trip and reset points are based on the Adjustable frequency drive power size.

Troubleshooting

Check for the following conditions.

Ambient temperature too high.

Motor cable too long.

Incorrect airflow clearance above and below the Adjustable frequency drive.

Blocked airflow around the Adjustable frequency drive.

Damaged heatsink fan.

Dirty heatsink.

ALARM 30, Motor phase U missing

Motor phase U between the Adjustable frequency drive and the motor is missing.

Remove power from the Adjustable frequency drive and check motor phase U.

ALARM 31, Motor phase V missing

Motor phase V between the Adjustable frequency drive and the motor is missing.

Remove power from the Adjustable frequency drive and check motor phase V.

ALARM 32, Motor phase W missing

Motor phase W between the Adjustable frequency drive and the motor is missing.

Remove power from the Adjustable frequency drive and check motor phase W.

ALARM 33, Inrush fault

Too many power-ups have occurred within a short time period. Let the unit cool to operating temperature.

WARNING/ALARM 34, communication fault

Communication between the and the communication option card is not operating.

WARNING/ALARM 35, Option fault

An option alarm is received. The alarm is option specific. The most likely cause is a power-up or a communication fault.

WARNING/ALARM 36, Line failure

This warning/alarm is only active if the supply voltage to the Adjustable frequency drive is lost and *14-10 Mains Failure* is NOT set to [0] *No Function*. Check the fuses to the Adjustable frequency drive and line power supply to the unit.

ALARM 37, Imb of sup volt

There is a current imbalance between the power units

ALARM 38, Internal fault

When an internal fault occurs, a code number defined in the table below is displayed.

Troubleshooting

Cycle power to the Adjustable frequency drive.

Check that the option is properly installed.

Check for loose or missing wiring.

It may be necessary to contact your Danfoss supplier or service department. Note the code number for further troubleshooting directions.

No.	Text
0	Serial port cannot be initialized. Contact yourDanfoss supplier or DanfossService Department.
256-258	Power EEPROM data is defect or too old
512-519	Internal fault. Contact yourDanfoss supplier or DanfossService Department.
783	Parameter value outside of min/max limits
1024-1284	Internal fault. Contact your Danfoss supplier or the Danfoss Service Department.
1299	Option SW in slot A is too old
1300	Option SW in slot B is too old
1302	Option SW in slot C1 is too old
1315	Option SW in slot A is not supported (not allowed)
1316	Option SW in slot B is not supported (not allowed)
1318	Option SW in slot C1 is not supported (not allowed)
1379-2819	Internal fault. Contact yourDanfoss supplier or DanfossService Department.
2820	LCP stack overflow
2821	Serial port overflow
2822	USB port overflow
3072-5122	Parameter value is outside its limits
5123	Option in slot A: Hardware incompatible with control board hardware
5124	Option in slot B: Hardware incompatible with control board hardware
5125	Option in slot C0: Hardware incompatible with control board hardware
5126	Option in slot C1: Hardware incompatible with control board hardware
5376-6231	Internal fault. Contact yourDanfoss supplier or DanfossService Department.

ALARM 39, Heatsink sensor

No feedback from the heatsink temperature sensor.

The signal from the IGBT thermal sensor is not available on the power card. The problem could be on the power card, on the gate drive card, or the ribbon cable between the power card and gate drive card.

WARNING 40, Overload of digital output terminal 27

Check the load connected to terminal 27 or remove short-circuit connection. Check *5-00 Digital I/O Mode* and *5-01 Terminal 27 Mode*.

WARNING 41, Overload of digital output terminal 29

Check the load connected to terminal 29 or remove short-circuit connection. Check *5-00 Digital I/O Mode* and *5-02 Terminal 29 Mode*.

WARNING 42, Overload of digital output on X30/6 or overload of digital output on X30/7

For X30/6, check the load connected to X30/6 or remove short-circuit connection. Check *5-32 Term X30/6 Digi Out (MCB 101)*.

For X30/7, check the load connected to X30/7 or remove short-circuit connection. Check *5-33 Term X30/7 Digi Out (MCB 101)*.

ALARM 43, Ext. supply

MCB 113 Ext. Relay Option is mounted without ext. 24 V DC. Either connect an ext. 24 V DC supply or specify that no external supply is used via *14-80 Option Supplied by External 24VDC [0]*. A change in *14-80 Option Supplied by External 24VDC* requires a power cycle.

ALARM 45, Earth Fault 2

Ground fault on start-up.

Troubleshooting

Check for proper grounding and loose connections.

Check for proper wire size.

Check motor cables for short-circuits or leakage currents.

ALARM 46, Power card supply

The supply on the power card is out of range.

There are three power supplies generated by the switch mode power supply (SMPS) on the power card: 24V, 5V, +/- 18V. When powered with 24V DC with the MCB 107 option, only the 24V and 5V supplies are monitored. When powered with three phase AC line voltage, all three supplied are monitored.

Troubleshooting

Check for a defective power card.

Check for a defective control card.

Check for a defective option card.

If a 24V DC power supply is used, verify proper supply power.

WARNING 47, 24V supply low

The 24 V DC is measured on the control card. The external 24V DC backup power supply may be overloaded; otherwise, contact your Danfoss supplier.

WARNING 48, 1.8V supply low

The 1.8V DC supply used on the control card is outside of allowable limits. The power supply is measured on the control card. Check for a defective control card. If an option card is present, check for an overvoltage condition.

WARNING 49, Speed limit

When the speed is not within the specified range in *4-11 Motor Speed Low Limit [RPM]* and *4-13 Motor Speed High Limit [RPM]*, the Adjustable frequency drive will show a warning. When the speed is below the specified limit in *1-86 Trip Speed Low [RPM]* (except when starting or stopping) the Adjustable frequency drive will trip.

ALARM 50, AMA calibration failed

Contact your Danfoss supplier or Danfoss Service Department.

ALARM 51, AMA check U_{nom} and I_{nom}

The settings for motor voltage, motor current, and motor power are wrong. Check the settings in parameters 1-20 to 1-25.

ALARM 52, AMA low I_{nom}

The motor current is too low. Check the setting in *4-18 Current Limit*.

ALARM 53, AMA motor too big

The motor is too big for the AMA to operate.

ALARM 54, AMA motor too small

The motor is too small for the AMA to operate.

ALARM 55, AMA Parameter out of range

The parameter values of the motor are outside of the acceptable range. AMA will not run.

ALARM 56, AMA interrupted by user

The AMA has been interrupted by the user.

ALARM 57, AMA timeout

Try to restart AMA again. Repeated restarts may overheat the motor.

ALARM 58, AMA internal fault

Contact your Danfoss supplier.

WARNING 59, Current limit

The current is higher than the value in *4-18 Current Limit*. Ensure that Motor data in parameters 1-20 through 1-25 are set correctly. Possibly increase the current limit. Be sure the system can operate safely at a higher limit.

ALARM 60, Ext. Interlock

A digital input signal is indicating a fault condition external to the Adjustable frequency drive. An external interlock has commanded the Adjustable frequency drive to trip. Clear the external fault condition. To resume normal operation, apply 24V DC to the terminal programmed for external interlock. Reset the Adjustable frequency drive.

WARNING/ALARM 61, Tracking error

An error between calculated speed and speed measurement from feedback device. The function Warning/Alarm/Disabling setting is in *4-30 Motor Feedback Loss Function*. Accepted error setting in *4-31 Motor Feedback Speed Error* and the allowed time the error occur setting in *4-32 Motor Feedback Loss Timeout*. During a commissioning procedure the function may be effective.

WARNING 62, Output frequency at maximum limit

The output frequency has reached the value set in *4-19 Max Output Frequency*. Check the application to determine the cause. Possibly increase the output frequency limit. Be sure the system can operate safely at a higher output frequency. The warning will clear when the output drops below the maximum limit.

ALARM 63, Mechanical brake low

The actual motor current has not exceeded the "release brake" current within the "Start delay" time window.

WARNING/ALARM 65, Control card over temperature

The cutout temperature of the control card is 176°F [80°C].

Troubleshooting

Check that the ambient operating temperature is within limits.

Check for clogged filters.

Check fan operation.

Check the control card.

WARNING 66, Heatsink temperature low

The Adjustable frequency drive is too cold to operate. This warning is based on the temperature sensor in the IGBT module. Increase the ambient temperature of the unit. Also a trickle amount of current can be supplied to the Adjustable frequency drive whenever the motor is stopped by setting *2-00 DC Hold/Preheat Current* at 5% and *1-80 Function at Stop*.

ALARM 67, Option change

One or more options have either been added or removed since the last power-down. Check that the configuration change is intentional and reset the Adjustable frequency drive.

ALARM 68, Safe Stop

Loss of the 24V DC signal on terminal 37 has caused the Adjustable frequency drive to trip. To resume normal operation, apply 24V DC to terminal 37 and reset the Adjustable frequency drive.

ALARM 69, Power card temperature Power card temperature

The temperature sensor on the power card is either too hot or too cold.

Troubleshooting

Check that the ambient operating temperature is within limits.

Check for clogged filters.

Check fan operation.

Check the power card.

ALARM 70, Illegal FC configuration

The control card and power card are incompatible. Contact your supplier with the typecode of the unit from the nameplate and the part numbers of the cards to check compatibility.

ALARM 71, PTC 1 safe stop

Safe Stop has been activated from the MCB 112 PTC Thermistor Card (motor too warm). Normal operation can be resumed when the MCB 112 applies 24 V DC to T-37 again (when the motor temperature reaches an acceptable level) and when the digital input from the MCB 112 is deactivated. When that happens, a reset signal must be sent (via Bus, Digital I/O, or by pressing [RESET]).

ALARM 72, Dang. failure

Safe Stop with Trip Lock. The dangerous failure alarm is issued if the combination of safe stop commands is unexpected. This is the case if the MCB 112 VLT PTC Thermistor Card enables X44/10 but safe stop is somehow not enabled. Furthermore, if the MCB 112 is the only device using safe stop (specified through selection [4] or [5] in *5-19 Terminal 37 Safe Stop*), an unexpected combination is activation of safe stop without the X44/10 being activated. The following table summarizes the unexpected combinations that lead to Alarm 72. Note that if X44/10 is activated in selection 2 or 3, this signal is ignored! However, the MCB 112 will still be able to activate safe stop.

WARNING 73, Safe stop auto restart

Safe stopped. Note that with automatic restart enabled, the motor may start when the fault is cleared.

ALARM 74, PTC Thermistor

Alarm related to the ATEX option. The PTC is not working.

ALARM 75, Illegal profile sel.

Parameter value must not be written while motor is running. Stop motor before writing MCO profile to *8-10 Control Word Profile* for instance.

WARNING 76, Power unit set-up

The required number of power units does not match the detected number of active power units.

Troubleshooting:

When replacing an F-frame module, this will occur if the power specific data in the module power card does not match the rest of the Adjustable frequency drive. Please confirm the spare part and its power card are the correct part number.

77 WARNING, Reduced power mode

This warning indicates that the Adjustable frequency drive is operating in reduced power mode (i.e., less than the allowed number of inverter sections). This warning will be generated on power cycle when the Adjustable frequency drive is set to run with fewer inverters and will remain on.

ALARM 78, Tracking error

The difference between setpoint value and actual value has exceeded the value in *4-35 Tracking Error*. Disable the function by *4-34 Tracking Error Function* or select an alarm/warning also in *4-34 Tracking Error Function*. Investigate the mechanics around the load and motor. Check feedback connections from motor – encoder – to Adjustable frequency drive. Select motor feedback function in *4-30 Motor Feedback Loss Function*. Adjust tracking error band in *4-35 Tracking Error* and *4-37 Tracking Error Ramping*.

ALARM 79, Illegal power section configuration

The scaling card is the incorrect part number or not installed. Also MK102 connector on the power card could not be installed.

ALARM 80, Drive initialized to default value

Parameter settings are initialized to default settings after a manual reset. Reset the unit to clear the alarm.

ALARM 81, CSIV corrupt

CSIV file has syntax errors.

ALARM 82, CSIV par. err.

CSIV failed to init a parameter.

ALARM 83, Illegal option combination

The mounted options are not supported to work together.

ALARM 84, No safety option

The safety option was removed without applying a general reset. Reconnect the safety option.

ALARM 88, Option detection

A change in the option layout has been detected. This alarm occurs when *14-89 Option Detection* is set to [0] *Frozen configuration* and the option layout for some reason has changed. An option layout change has to be enabled in *14-89 Option Detection* before the change is accepted. If the change of configuration is not accepted, it is only possible to reset Alarm 88 (Trip-lock) when the option configuration has been re-established/corrected.

WARNING 89, Mechanical brake sliding

The hoist brake monitor has detected a motor speed > 10rpm.

ALARM 90, Feedback mon.

Check the connection to encoder/ resolver option and eventually replace the MCB 102 or MCB 103.

ALARM 91, Analogue input 54 wrong settings

Switch S202 has to be set in position OFF (voltage input) when a KTY sensor is connected to analog input terminal 54.

ALARM 92, No flow

A no-flow condition has been detected in the system. *22-23 No-Flow Function* is set for alarm. Troubleshoot the system and reset the Adjustable frequency drive after the fault has been cleared.

ALARM 93, Dry pump

A no-flow condition in the system with the Adjustable frequency drive operating at high speed may indicate a dry pump. *22-26 Dry Pump Function* is set for alarm. Troubleshoot the system and reset the Adjustable frequency drive after the fault has been cleared.

ALARM 94, End of curve

Feedback is lower than the setpoint. This may indicate leakage in the system. *22-50 End of Curve Function* is set for alarm. Troubleshoot the system and reset the Adjustable frequency drive after the fault has been cleared.

ALARM 95, Broken belt

Torque is below the torque level set for no load, indicating a broken belt. *22-60 Broken Belt Function* is set for alarm. Troubleshoot the system and reset the Adjustable frequency drive after the fault has been cleared.

ALARM 96, Start delayed

Motor start has been delayed due to short-cycle protection. *22-76 Interval between Starts* is enabled. Troubleshoot the system and reset the Adjustable frequency drive after the fault has been cleared.

WARNING 97, Stop delayed

Stopping the motor has been delayed due to short cycle protection. *22-76 Interval between Starts* is enabled. Troubleshoot the system and reset the Adjustable frequency drive after the fault has been cleared.

WARNING 98, Clock fault

Time is not set or the RTC clock has failed. Reset the clock in *0-70 Date and Time*.

WARNING 163, ATEX ETR cur.lim.warning

The warning limit of ATEX ETR rated current curve has been reached. The warning is activated at 83% and deactivated at 65% of the permitted thermal overload.

ALARM 164, ATEX ETR cur.lim.alarm

The ATEX ETR permitted thermal overload has been exceeded.

WARNING 165, ATEX ETR freq.lim.warning

The Adjustable frequency drive is running more than 50 seconds below the permitted minimum frequency (*1-98 ATEX ETR interpol. points freq. [0]*).

ALARM 166, ATEX ETR freq.lim.alarm

The Adjustable frequency drive has operated more than 60 second (in a period of 600 seconds) below the permitted minimum frequency (*1-98 ATEX ETR interpol. points freq. [0]*).

ALARM 243, Brake IGBT

This alarm is only for F Frame drives. It is equivalent to Alarm 27. The report value in the alarm log indicates which power module generated the alarm:

ALARM 244, Heatsink temp

This alarm is only for F Frame adjustable frequency drives. It is equivalent to Alarm 29. The report value in the alarm log indicates which power module generated the alarm:

ALARM 245, Heatsink sensor

This alarm is only for F Frame adjustable frequency drives. It is equivalent to Alarm 39. The report value in the alarm log indicates which power module generated the alarm.

1 = left most inverter module.

2 = middle inverter module in F2 or F4 Adjustable frequency drive.

2 = right inverter module in F1 or F3 Adjustable frequency drive.

3 = right inverter module in F2 or F4 Adjustable frequency drive.

5 = rectifier module.

ALARM 246, Power card supply

This alarm is only for F Frame Adjustable frequency drive. It is equivalent to Alarm 46. The report value in the alarm log indicates which power module generated the alarm.

1 = left most inverter module.

2 = middle inverter module in F2 or F4 Adjustable frequency drive.

2 = right inverter module in F1 or F3 Adjustable frequency drive.

3 = right inverter module in F2 or F4 Adjustable frequency drive.

5 = rectifier module.

ALARM 69, Power card temperature Power card temperature

This alarm is only for F Frame Adjustable frequency drive. It is equivalent to Alarm 69. The report value in the alarm log indicates which power module generated the alarm.

1 = left most inverter module.

2 = middle inverter module in F2 or F4 Adjustable frequency drive.

2 = right inverter module in F1 or F3 Adjustable frequency drive.

3 = right inverter module in F2 or F4 Adjustable frequency drive.

5 = rectifier module.

ALARM 248, Illegal power section configuration

This alarm is only for F Frame adjustable frequency drives. It is equivalent to Alarm 79. The report value in the alarm log indicates which power module generated the alarm:

1 = left most inverter module.

2 = middle inverter module in F2 or F4
Adjustable frequency drive.

2 = right inverter module in F1 or F3 Adjustable
frequency drive.

3 = right inverter module in F2 or F4 Adjustable
frequency drive.

5 = rectifier module.

WARNING 249, Rect. low temperature

IGBT sensor fault (highpower units only).

WARNING 250, New spare part

A component in the Adjustable frequency drive has been replaced. Reset the Adjustable frequency drive for normal operation.

WARNING 251, New Type Code

A component in the Adjustable frequency drive has been replaced and the typecode changed. Reset the Adjustable frequency drive for normal operation.

9 Basic Troubleshooting

9.1 Start Up and Operation

See *Alarm Log* in *Table 4.1*.

Symptom	Possible Cause	Test	Solution
Display dark / No function	Missing input power	See <i>Table 3.1</i> .	Check the input power source.
	Missing or open fuses or circuit breaker tripped	See open fuses and tripped circuit breaker in this table for possible causes.	Follow the recommendations provided
	No power to the LCP	Check the LCP cable for proper connection or damage.	Replace the faulty LCP or connection cable.
	Shortcut on control voltage (terminal 12 or 50) or at control terminals	Check the 24V control voltage supply for terminal 12/13 to 20-39 or 10V supply for terminal 50 to 55.	Wire the terminals properly.
	Wrong LCP (LCP from VLT® 2800 or 5000/6000/8000/ FCD or FCM)		Use only LCP 101 (P/N 130B1124) or LCP 102 (P/N. 130B1107).
	Wrong contrast setting		Press [Status] + Up/Down arrows to adjust the contrast.
	Display (LCP) is defective	Test using a different LCP.	Replace the faulty LCP or connection cable.
	Internal voltage supply fault or SMPS is defective		Contact supplier.
Intermittent display	Overloaded power supply (SMPS) due to improper control wiring or a fault within the Adjustable frequency drive	To rule out a problem in the control wiring, disconnect all control wiring by removing the terminal blocks.	If the display stays lit, then the problem is in the control wiring. Check the wiring for shorts or incorrect connections. If the display continues to cut out, follow the procedure for display dark.

Symptom	Possible Cause	Test	Solution
Motor not running	Service switch open or missing motor connection	Check if the motor is connected and the connection is not interrupted (by a service switch or other device).	Connect the motor and check the service switch.
	No line power with 24V DC option card	If the display is functioning but no output, check that line power is applied to the Adjustable frequency drive.	Apply line power to run the unit.
	LCP Stop	Check if [Off] has been pressed.	Press [Auto On] or [Hand On] (depending on your operation mode) to run the motor.
	Missing start signal (Standby)	Check 5-10 <i>Start</i> for correct setting for terminal 18 (use default setting).	Apply a valid start signal to start the motor.
	Motor coast signal active (Coasting)	Check 5-12 <i>Coast inv.</i> for correct setting for terminal 27 (use default setting).	Apply 24V on terminal 27 or program this terminal to No operation.
	Wrong reference signal source	Check reference signal: Local, remote or bus reference? Preset reference active? Terminal connection correct? Scaling of terminals correct? Reference signal available?	Program correct settings Check 3-13 <i>Reference site</i> . Set preset reference active in parameter group 3-1* <i>References</i> . Check for correct wiring. Check scaling of terminals. Check reference signal.
Motor running in wrong direction	Motor rotation limit	Check that 4-10 <i>Motor speed direction</i> is programmed correctly.	Program correct settings.
	Active reversing signal	Check if a reversing command is programmed for the terminal in parameter group 5-1* <i>Digital inputs</i> .	Deactivate reversing signal.
	Wrong motor phase connection		See 3.5 <i>Check Motor Rotation</i> in this manual.
Motor is not reaching maximum speed	Frequency limits set wrong	Check output limits in 4-13 <i>Motor speed high limit [RPM]</i> , 4-14 <i>Motor speed high limit [Hz]</i> , and 4-19 <i>Max output frequency</i> .	Program correct limits.
	Reference input signal not scaled correctly	Check reference input signal scaling in 6-* <i>Analog I/O mode</i> and parameter group 3-1* <i>References</i> .	Program correct settings.
Motor speed unstable	Possible incorrect parameter settings	Check the settings of all motor parameters, including all motor compensation settings. For closed-loop operation, check PID settings.	Check settings in parameter group 1-6* <i>Analog I/O mode</i> . For closed-loop operation, check settings in parameter group 20-0* <i>Feedback</i> .
Motor runs rough	Possible overmagnetization	Check for incorrect motor settings in all motor parameters.	Check motor settings in parameter groups 1-2* <i>Motor data</i> , 1-3* <i>Adv motor data</i> , and 1-5* <i>Load indep. setting</i> .
Motor will not brake	Possible incorrect settings in the brake parameters. Possible too short ramp-down times.	Check brake parameters. Check ramp time settings.	Check parameter group 2-0* <i>DC brake</i> and 3-0* <i>Reference limits</i> .

Symptom	Possible Cause	Test	Solution
Open power fuses or circuit breaker trip	Phase to phase short	Motor or panel has a short phase to phase. Check motor and panel phase to phase for shorts.	Eliminate any shorts detected.
	Motor overload	Motor is overloaded for the application.	Perform start-up test and verify motor current is within specifications. If motor current is exceeding nameplate full load current, motor may run only with reduced load. Review the specifications for the application.
	Loose connections	Perform pre-startup check for loose connections.	Tighten loose connections.
Line power current imbalance greater than 3%	Problem with line power (See <i>Alarm 4 Line phase loss</i> description)	Rotate input power leads into the drive one position: A to B, B to C, C to A.	If imbalanced leg follows the wire, it is a power problem. Check line power supply.
	Problem with the Adjustable frequency drive unit	Rotate input power leads into the Adjustable frequency drive one position: A to B, B to C, C to A.	If imbalance leg stays on same input terminal, it is a problem with the unit. Contact supplier.
Motor current imbalance greater than 3%	Problem with motor or motor wiring	Rotate output motor leads one position: U to V, V to W, W to U.	If imbalanced leg follows the wire, the problem is in the motor or motor wiring. Check motor and motor wiring.
	Problem with drive unit	Rotate output motor leads one position: U to V, V to W, W to U.	If imbalance leg stays on same output terminal, it is a problem with the unit. Contact supplier.

10 Specifications

10.1 Power-dependent Specifications

Line Power Supply 3 x 200–240V AC										
FC 301/FC 302										
	PK25	PK37	PK55	PK75	P1K1	P1K5	P2K2	P3K0	P3K7	
Typical Shaft Output [kW]	0.25	0.37	0.55	0.75	1.1	1.5	2.2	3	3.7	
Enclosure IP20/IP21	A2	A2	A2	A2	A2	A2	A2	A3	A3	
Enclosure IP 20 (FC 301 only)	A1	A1	A1	A1	A1	A1	-	-	-	
Enclosure IP 55, 66	A4/A5	A4/A5	A4/A5	A4/A5	A4/A5	A4/A5	A4/A5	A5	A5	
Output current										
Continuous (3 x 200–240V) [A]	1.8	2.4	3.5	4.6	6.6	7.5	10.6	12.5	16.7	
Intermittent (3 x 200–240V) [A]	2.9	3.8	5.6	7.4	10.6	12.0	17.0	20.0	26.7	
Continuous kVA (208V AC) [kVA]	0.65	0.86	1.26	1.66	2.38	2.70	3.82	4.50	6.00	
Max. input current										
Continuous (3 x 200–240V) [A]	1.6	2.2	3.2	4.1	5.9	6.8	9.5	11.3	15.0	
Intermittent (3 x 200–240V) [A]	2.6	3.5	5.1	6.6	9.4	10.9	15.2	18.1	24.0	
Additional specifications										
Max. cable size (line power, motor, brake) [mm ² (AWG ²)]	0.2–4 (24–10)									
Estimated power loss at rated max. load [W] ⁴⁾	21	29	42	54	63	82	116	155	185	
Weight, enclosure IP20 [kg]	4.7	4.7	4.8	4.8	4.9	4.9	4.9	6.6	6.6	
A1 (IP20)	2.7	2.7	2.7	2.7	2.7	2.7	-	-	-	
A5 (IP 55, 66)	13.5	13.5	13.5	13.5	13.5	13.5	13.5	13.5	13.5	
Efficiency ⁴⁾	0.94	0.94	0.95	0.95	0.96	0.96	0.96	0.96	0.96	

0.25–3.7 kW only available as 160% high overload.

Line Power Supply 3 x 200–240V AC							
FC 301/FC 302							
High/ Normal Load ¹⁾	P5K5		P7K5		P11K		
	HO	NO	HO	NO	HO	NO	
Typical Shaft Output [kW]	5.5	7.5	7.5	11	11	15	
Enclosure IP20	B3		B3		B4		
Enclosure IP21	B1		B1		B2		
Enclosure IP55, 66	B1		B1		B2		
Output current							
Continuous (3 x 200–240V) [A]	24.2	30.8	30.8	46.2	46.2	59.4	
Intermittent (60 sec overload) (3 x 200–240V) [A]	38.7	33.9	49.3	50.8	73.9	65.3	
Continuous kVA (208V AC) [kVA]	8.7	11.1	11.1	16.6	16.6	21.4	
Max. input current							
Continuous (3 x 200–240V) [A]	22	28	28	42	42	54	
Intermittent (60 sec overload) (3 x 200–240V) [A]	35.2	30.8	44.8	46.2	67.2	59.4	
Additional specifications							
Max. cable size [mm ² (AWG)] ²⁾	16 (6)		16 (6)		35 (2)		
Max cable size with line power disconnect	16 (6)						
Estimated power loss at rated max. load [W] ⁴⁾	239	310	371	514	463	602	
Weight, enclosure IP21, IP55, 66 [kg]	23		23		27		
Efficiency ⁴⁾	0.964		0.959		0.964		

Line Power Supply 3 x 200–240V AC											
FC 301/FC 302		P15K		P18K		P22K		P30K		P37K	
High/ Normal Load ¹⁾		HO	NO	HO	NO	HO	NO	HO	NO	HO	NO
Typical Shaft Output [kW]		15	18.5	18.5	22	22	30	30	37	37	45
Enclosure IP20		B4		C3		C3		C4		C4	
Enclosure IP21		C1		C1		C1		C1		C1	
Enclosure IP55, 66		C1		C1		C1		C2		C2	
Output current											
Continuous (3 x 200–240V) [A]		59.4	74.8	74.8	88	88	115	115	143	143	170
Intermittent (60 sec overload) (3 x 200–240V) [A]		89.1	82.3	112	96.8	132	127	173	157	215	187
Continuous kVA (208V AC) [kVA]		21.4	26.9	26.9	31.7	31.7	41.4	41.4	51.5	51.5	61.2
Max. input current											
Continuous (3 x 200–240V) [A]		54	68	68	80	80	104	104	130	130	154
Intermittent (60 sec overload) (3 x 200–240V) [A]		81	74.8	102	88	120	114	156	143	195	169
Additional specifications											
Max. cable size, IP20 [mm ² (AWG)] ²⁾		35 (2)		90 (3/0)		90 (3/0)		120 (4/0)		120 (4/0)	
Max. cable size, IP21/55/66 [mm ² (AWG)] ²⁾		90 (3/0)		90 (3/0)		90 (3/0)		120 (4/0)		120 (4/0)	
Max. cable size with line power disconnect [mm ² (AWG)] ²⁾		35 (2)						70 (3/0)		150 (MCM 300)	
Estimated power loss at rated max. load [W] ⁴⁾		624	737	740	845	874	1140	1143	1353	1400	1636
Weight, enclosure IP21, IP 55, 66 [kg]		45		45		45		65		65	
Efficiency ⁴⁾		0.96		0.97		0.97		0.97		0.97	

Line Power Supply 3 x 380–500V AC (FC 302), 3 x 380–480V AC (FC 301)										
	PK 37	PK 55	PK75	P1K1	P1K5	P2K2	P3K0	P4K0	P5K5	P7K5
FC 301/FC 302 Typical Shaft Output [kW]	0.37	0.55	0.75	1.1	1.5	2.2	3	4	5.5	7.5
Enclosure IP20/IP21	A2	A2	A2	A2	A2	A2	A2	A2	A3	A3
Enclosure IP20 (FC 301 only)	A1	A1	A1	A1	A1					
Enclosure IP 55, 66	A4/A5	A4/A5	A4/A5	A4/A5	A4/A5	A4/A5	A4/A5	A4/A5	A5	A5
Output current										
High overload 160% for 1 min.										
Shaft output [kW]	0.37	0.55	0.75	1.1	1.5	2.2	3	4	5.5	7.5
Continuous (3 x 380–440V) [A]	1.3	1.8	2.4	3	4.1	5.6	7.2	10	13	16
Intermittent (3 x 380–440V) [A]	2.1	2.9	3.8	4.8	6.6	9.0	11.5	16	20.8	25.6
Continuous (3 x 441–500V) [A]	1.2	1.6	2.1	2.7	3.4	4.8	6.3	8.2	11	14.5
Intermittent (3 x 441–500V) [A]	1.9	2.6	3.4	4.3	5.4	7.7	10.1	13.1	17.6	23.2
Continuous kVA (400V AC) [kVA]	0.9	1.3	1.7	2.1	2.8	3.9	5.0	6.9	9.0	11.0
Continuous kVA (460V AC) [kVA]	0.9	1.3	1.7	2.4	2.7	3.8	5.0	6.5	8.8	11.6
Max. input current										
Continuous (3 x 380–440V) [A]	1.2	1.6	2.2	2.7	3.7	5.0	6.5	9.0	11.7	14.4
Intermittent (3 x 380–440V) [A]	1.9	2.6	3.5	4.3	5.9	8.0	10.4	14.4	18.7	23.0
Continuous (3 x 441–500V) [A]	1.0	1.4	1.9	2.7	3.1	4.3	5.7	7.4	9.9	13.0
Intermittent (3 x 441–500V) [A]	1.6	2.2	3.0	4.3	5.0	6.9	9.1	11.8	15.8	20.8
Additional specifications										
Max. cable size (line power, motor, brake) [AWG] ²⁾ [mm ²]	24–10 AWG 0.2–4 mm ²						24–10 AWG 0.2–4 mm ²			
Estimated power loss at rated max. load [W] ⁴⁾	35	42	46	58	62	88	116	124	187	255
Weight, enclosure IP20	4.7	4.7	4.8	4.8	4.9	4.9	4.9	4.9	6.6	6.6
Enclosure IP 55, 66	13.5	13.5	13.5	13.5	13.5	13.5	13.5	13.5	14.2	14.2
Efficiency ⁴⁾	0.93	0.95	0.96	0.96	0.97	0.97	0.97	0.97	0.97	0.97

0.33–10 hp [0.37–7.5 kW] only available as 160% high overload.

Line Power Supply 3 x 380–500V AC (FC 302), 3 x 380–480V AC (FC 301)									
FC 301/FC 302		P11K		P15K		P18K		P22K	
High/ Normal Load ¹⁾		HO	NO	HO	NO	HO	NO	HO	NO
Typical Shaft output [kW]		11	15	15	18.5	18.5	22.0	22.0	30.0
Enclosure IP20		B3		B3		B4		B4	
Enclosure IP21		B1		B1		B2		B2	
Enclosure IP55, 66		B1		B1		B2		B2	
Output current									
Continuous (3 x 380–440V) [A]		24	32	32	37.5	37.5	44	44	61
Intermittent (60 sec overload) (3 x 380–440V) [A]		38.4	35.2	51.2	41.3	60	48.4	70.4	67.1
Continuous (3 x 441–500V) [A]		21	27	27	34	34	40	40	52
Intermittent (60 sec overload) (3 x 441–500V) [A]		33.6	29.7	43.2	37.4	54.4	44	64	57.2
Continuous kVA (400V AC) [kVA]		16.6	22.2	22.2	26	26	30.5	30.5	42.3
Continuous kVA (460V AC) [kVA]			21.5		27.1		31.9		41.4
Max. input current									
Continuous (3 x 380–440V) [A]		22	29	29	34	34	40	40	55
Intermittent (60 sec overload) (3 x 380–440V) [A]		35.2	31.9	46.4	37.4	54.4	44	64	60.5
Continuous (3 x 441–500V) [A]		19	25	25	31	31	36	36	47
Intermittent (60 sec overload) (3 x 441–500V) [A]		30.4	27.5	40	34.1	49.6	39.6	57.6	51.7
Additional specifications									
Max. cable size [mm ² /AWG] ²⁾		16/6		16/6		35/2		35/2	
Max cable size with line power disconnect		16/6							
Estimated power loss at rated max. load [W] ⁴⁾		291	392	379	465	444	525	547	739
Weight, enclosure IP20 [kg]		12		12		23.5		23.5	
Weight, enclosure IP21, IP55, 66 [kg]		23		23		27		27	
Efficiency ⁴⁾		0.98		0.98		0.98		0.98	

Line Power Supply 3 x 380–500 V AC (FC 302), 3 x 380–480V AC (FC 301)											
FC 301/FC 302		P30K		P37K		P45K		P55K		P75K	
High/ Normal Load ¹⁾		HO	NO	HO	NO	HO	NO	HO	NO	HO	NO
Typical Shaft output [kW]		30	37	37	45	45	55	55	75	75	90
Enclosure IP20		B4		C3		C3		C4		C4	
Enclosure IP21		C1		C1		C1		C2		C2	
Enclosure IP55, 66		C1		C1		C1		C2		C2	
Output current											
Continuous (3 x 380–440V) [A]		61	73	73	90	90	106	106	147	147	177
Intermittent (60 sec. overload) (3 x 380–440V) [A]		91.5	80.3	110	99	135	117	159	162	221	195
Continuous (3 x 441–500V) [A]		52	65	65	80	80	105	105	130	130	160
Intermittent (60 sec. overload) (3 x 441–500V) [A]		78	71.5	97.5	88	120	116	158	143	195	176
Continuous kVA (400V AC) [kVA]		42.3	50.6	50.6	62.4	62.4	73.4	73.4	102	102	123
Continuous kVA (460V AC) [kVA]			51.8		63.7		83.7		104		128
Max. input current											
Continuous (3 x 380–440V) [A]		55	66	66	82	82	96	96	133	133	161
Intermittent (60 sec. overload) (3 x 380–440V) [A]		82.5	72.6	99	90.2	123	106	144	146	200	177
Continuous (3 x 441–500V) [A]		47	59	59	73	73	95	95	118	118	145
Intermittent (60 sec. overload) (3 x 441–500V) [A]		70.5	64.9	88.5	80.3	110	105	143	130	177	160
Additional specifications											
Max. cable size IP20, line power and motor [mm ² (AWG ²⁾]		35 (2)		50 (1)		50 (1)		95 (4/0)		150 (300 mcm)	
Max. cable size IP20, load share and brake [mm ² (AWG ²⁾]		35 (2)		50 (1)		50 (1)		95 (4/0)		95 (4/0)	
Max. cable size, IP21/55/66 [mm ² (AWG ²⁾]		90 (3/0)		90 (3/0)		90 (3/0)		120 (4/0)		120 (4/0)	
Max. cable size with line power disconnect [mm ² (AWG ²⁾]		35 (2)						70 (3/0)		150 (300 mcm)	
Estimated power loss at rated max. load [W] ⁴⁾		570	698	697	843	891	1083	1022	1384	1232	1474
Weight, enclosure IP21, IP55, 66 [kg]		45		45		45		65		65	
Efficiency ⁴⁾		0.98		0.98		0.98		0.98		0.99	

Line Power Supply 3 x 525–600V AC (FC 302 only)										
FC 302		PK75	P1K1	P1K5	P2K2	P3K0	P4K0	P5K5	P7K5	
	Typical Shaft Output [kW]	0.75	1.1	1.5	2.2	3	4	5.5	7.5	
	Enclosure IP20, 21	A3	A3	A3	A3	A3	A3	A3	A3	
	Enclosure IP55	A5	A5	A5	A5	A5	A5	A5	A5	
Output current										
	Continuous (3 x 525–550V) [A]	1.8	2.6	2.9	4.1	5.2	6.4	9.5	11.5	
	Intermittent (3 x 525–550V) [A]	2.9	4.2	4.6	6.6	8.3	10.2	15.2	18.4	
	Continuous (3 x 551–600V) [A]	1.7	2.4	2.7	3.9	4.9	6.1	9.0	11.0	
	Intermittent (3 x 551–600V) [A]	2.7	3.8	4.3	6.2	7.8	9.8	14.4	17.6	
	Continuous kVA (525 V AC) [kVA]	1.7	2.5	2.8	3.9	5.0	6.1	9.0	11.0	
	Continuous kVA (575V AC) [kVA]	1.7	2.4	2.7	3.9	4.9	6.1	9.0	11.0	
Max. input current										
	Continuous (3 x 525–600V) [A]	1.7	2.4	2.7	4.1	5.2	5.8	8.6	10.4	
	Intermittent (3 x 525–600V) [A]	2.7	3.8	4.3	6.6	8.3	9.3	13.8	16.6	
Additional specifications										
	Max. cable size (line power, motor, brake) [AWG] ²⁾ [mm ²]	24–10 AWG 0.2–4 mm ²					24–10 AWG 0.2–4 mm ²			
	Estimated power loss at rated max. load [W] ⁴⁾	35	50	65	92	122	145	195	261	
	Weight, Enclosure IP20 [kg]	6.5	6.5	6.5	6.5	6.5	6.5	6.6	6.6	
	Weight, enclosure IP55 [kg]	13.5	13.5	13.5	13.5	13.5	13.5	14.2	14.2	
	Efficiency ⁴⁾	0.97	0.97	0.97	0.97	0.97	0.97	0.97	0.97	

Specifications **VLT® Automation Drive Instruction Manual**

Line Power Supply 3 x 525–600V AC											
FC 302	P11K		P15K		P18K		P22K		P30K		
High/ Normal Load ¹⁾	HO	NO	HO	NO	HO	NO	HO	NO	HO	NO	
Typical Shaft Output [kW]	11	15	15	18.5	18.5	22	22	30	30	37	
Enclosure IP21, 55, 66	B1		B1		B2		B2		C1		
	B3		B3		B4		B4		B4		
Output current											
Continuous (3 x 525–550V) [A]	19	23	23	28	28	36	36	43	43	54	
Intermittent (3 x 525–550V) [A]	30	25	37	31	45	40	58	47	65	59	
Continuous (3 x 525–600V) [A]	18	22	22	27	27	34	34	41	41	52	
Intermittent (3 x 525–600V) [A]	29	24	35	30	43	37	54	45	62	57	
Continuous kVA (550V AC) [kVA]	18.1	21.9	21.9	26.7	26.7	34.3	34.3	41.0	41.0	51.4	
Continuous kVA (575V AC) [kVA]	17.9	21.9	21.9	26.9	26.9	33.9	33.9	40.8	40.8	51.8	
Max. input current											
Continuous at 550V [A]	17.2	20.9	20.9	25.4	25.4	32.7	32.7	39	39	49	
Intermittent at 550V [A]	28	23	33	28	41	36	52	43	59	54	
Continuous at 575V [A]	16	20	20	24	24	31	31	37	37	47	
Intermittent at 575 V [A]	26	22	32	27	39	34	50	41	56	52	
Additional specifications											
Max. cable size IP20 (line power, motor, load share and brake) [mm ² (AWG ²⁾]	16(6)				35(2)						
Max. cable size IP21, 55, 66 (line power, motor, load share and brake) [mm ² (AWG ²⁾]	16(6)				35(2)					90 (3/0)	
Max. cable size with line power disconnect [mm ² (AWG ²⁾]	16(6)								35(2)		
Estimated power loss at rated max. load [W] ⁴⁾		225		285		329		700		700	
Weight, enclosure IP21, [kg]	23		23		27		27		27		
Weight, enclosure IP20 [kg]	12		12		23.5		23.5		23.5		
Efficiency ⁴⁾	0.98		0.98		0.98		0.98		0.98		

Line Power Supply 3 x 525–600V AC									
FC 302		P37K		P45K		P55K		P75K	
High/ Normal Load*		HO	NO	HO	NO	HO	NO	HO	NO
	Typical Shaft Output [kW]	37	45	45	55	55	75	75	90
	Enclosure IP21, 55, 66	C1	C1	C1		C2		C2	
	Enclosure IP20	C3	C3	C3		C4		C4	
Output current									
	Continuous (3 x 525–550V) [A]	54	65	65	87	87	105	105	137
	Intermittent (3 x 525–550V) [A]	81	72	98	96	131	116	158	151
	Continuous (3 x 525–600V) [A]	52	62	62	83	83	100	100	131
	Intermittent (3 x 525–600V) [A]	78	68	93	91	125	110	150	144
	Continuous kVA (550V AC) [kVA]	51.4	61.9	61.9	82.9	82.9	100.0	100.0	130.5
	Continuous kVA (575V AC) [kVA]	51.8	61.7	61.7	82.7	82.7	99.6	99.6	130.5
Max. input current									
	Continuous at 550V [A]	49	59	59	78.9	78.9	95.3	95.3	124.3
	Intermittent at 550V [A]	74	65	89	87	118	105	143	137
	Continuous at 575V [A]	47	56	56	75	75	91	91	119
	Intermittent at 575V [A]	70	62	85	83	113	100	137	131
Additional specifications									
	Max. cable size IP20 (line power, motor) [mm ² (AWG ²)]	50 (1)				95 (4/0)		150 (300 mcm)	
	Max. cable size IP20 (load share, brake) [AWG] ² [mm ²]	50 (1)				95 (4/0)			
	Max. cable size IP21, 55, 66 (line power, motor, load share and brake) [mm ² (AWG ²)]	90 (3/0)				120 (4/0)			
	Max cable size with line power disconnect	35 (2)				70 (3/0)		150 (300 mcm)	
	Estimated power loss at rated max. load [W] ⁴⁾	850		1100		1400		1500	
	Weight, enclosure IP20 [kg]	35		35		50		50	
	Weight, enclosure IP21, 55 [kg]	45		45		65		65	
	Efficiency ⁴⁾	0.98		0.98		0.98		0.98	

Line Power Supply 3 x 525–690V AC									
FC 302		P11K		P15K		P18K		P22K	
High/ Normal Load ¹⁾		HO	NO	HO	NO	HO	NO	HO	NO
	Typical Shaft output at 550V [kW]	7.5	11	11	15	15	18.5	18.5	22
	Typical Shaft output at 575V [HP]	11	15	15	20	20	25	25	30
	Typical Shaft output at 690V [kW]	11	15	15	18.5	18.5	22	22	30
	Enclosure IP21, 55	B2		B2		B2		B2	
Output current									
	Continuous (3 x 525–550V) [A]	14	19	19	23	23	28	28	36
	Intermittent (60 sec overload) (3 x 525–550V) [A]	22.4	20.9	30.4	25.3	36.8	30.8	44.8	39.6
	Continuous (3 x 551–690V) [A]	13	18	18	22	22	27	27	34
	Intermittent (60 sec overload) (3 x 551–690V) [A]	20.8	19.8	28.8	24.2	35.2	29.7	43.2	37.4
	Continuous KVA (at 550V) [KVA]	13.3	18.1	18.1	21.9	21.9	26.7	26.7	34.3
	Continuous KVA (at 575V) [KVA]	12.9	17.9	17.9	21.9	21.9	26.9	26.9	33.9
	Continuous KVA (at 690V) [KVA]	15.5	21.5	21.5	26.3	26.3	32.3	32.3	40.6
Max. input current									
	Continuous (3 x 525–690V) [A]	15	19.5	19.5	24	24	29	29	36
	Intermittent (60 sec overload) (3 x 525–690V) [A]	23.2	21.5	31.2	26.4	38.4	31.9	46.4	39.6
Additional specifications									
	Max. cable size, line power, motor, load share and brake [mm ² (AWG)]	35 (1/0)							
	Estimated power loss at rated max. load [W] ⁴⁾	228		285		335		375	
	Weight, enclosure IP21, IP55 [kg]	27							
	Efficiency ⁵⁾	0.98		0.98		0.98		0.98	

Line Power Supply 3 x 525–690V AC											
FC 302		P30K		P37K		P45K		P55K		P75K	
High/ Normal Load*		HO	NO	HO	NO	HO	NO	HO	NO	HO	NO
	Typical Shaft output at 550V [kW]	22	30	30	37	37	45	45	55	55	75
	Typical Shaft output at 575V [HP]	30	40	40	50	50	60	60	75	75	100
	Typical Shaft output at 690V [kW]	30	37	37	45	45	55	55	75	75	90
	Enclosure IP21, 55	C2		C2		C2		C2		C2	
Output current											
	Continuous (3 x 525–550V) [A]	36	43	43	54	54	65	65	87	87	105
	Intermittent (60 sec overload) (3 x 525–550V) [A]	54	47.3	64.5	59.4	81	71.5	97.5	95.7	130.5	115.5
	Continuous (3 x 551–690V) [A]	34	41	41	52	52	62	62	83	83	100
	Intermittent (60 sec overload) (3 x 551–690V) [A]	51	45.1	61.5	57.2	78	68.2	93	91.3	124.5	110
	Continuous KVA (at 550V) [KVA]	34.3	41.0	41.0	51.4	51.4	61.9	61.9	82.9	82.9	100.0
	Continuous KVA (at 575V) [KVA]	33.9	40.8	40.8	51.8	51.8	61.7	61.7	82.7	82.7	99.6
	Continuous KVA (at 690V) [KVA]	40.6	49.0	49.0	62.1	62.1	74.1	74.1	99.2	99.2	119.5
	Max. input current										
	Continuous (at 550V) [A]	36	49	49	59	59	71	71	87	87	99
	Continuous (at 575V) [A]	54	53.9	72	64.9	87	78.1	105	95.7	129	108.9
Additional specifications											
	Max. cable size, line power, motor, load share and brake [mm ² (AWG)]	95 (4/0)									
	Estimated power loss at rated max. load [W] ⁴⁾	480	592			720		880		1200	
	Weight, enclosure IP21, IP55 [kg]	65									
	Efficiency ⁴⁾	0.98	0.98			0.98		0.98		0.98	

For fuse ratings, see 10.3.1 Fuses

1) High overload = 160% torque during 60 sec., Normal overload = 110% torque during 60 sec.

2) American Wire Gauge.

3) Measured using 16.4 ft [5 m] shielded motor cables at rated load and rated frequency.

4) The typical power loss is at nominal load conditions and expected to be within +/-15% (tolerance relates to variety in voltage and cable conditions).

Values are based on a typical motor efficiency (eff2/eff3 border line). Motors with lower efficiency will also add to the power loss in the adjustable frequency drive and opposite.

If the switching frequency is increased compared to the default setting, the power losses may rise significantly.

LCP and typical control card power consumptions are included. Further options and customer load may add up to 30W to the losses.

(Though typical, only 4 W extra for a fully loaded control card, or options for slot A or slot B, each.)

Although measurements are made with state of the art equipment, some measurement inaccuracy must be allowed for (+/-5%).

10.2 General Technical Data

Line power supply (L1, L2, L3):

Supply voltage	200–240 V ±10%
Supply voltage	FC 301: 380–480 V / FC 302: 380–500 V ±10%
	FC 302: 525–600 V ±10%
Supply voltage	FC 302: 525–690 V ±10%

AC line voltage low / line drop-out:

During low AC line voltage or a line drop-out, the FC continues until the intermediate circuit voltage drops below the minimum stop level, which corresponds typically to 15% below the adjustable frequency drive's lowest rated supply voltage. Power-up and full torque cannot be expected at AC line voltage lower than 10% below the adjustable frequency drive's lowest rated supply voltage.

Supply frequency	50/60 Hz ±5%
Max. imbalance temporary between line phases	3.0% of rated supply voltage
True Power Factor (λ)	≥ 0.9 nominal at rated load
Displacement Power Factor ($\cos \phi$)	near unity (> 0.98)
Switching on input supply L1, L2, L3 (power-ups) ≤10 hp [7.5 kW]	maximum 2 times/min.
Switching on input supply L1, L2, L3 (power-ups) 15–100 hp [11–75 kW]	maximum 1 time/min.
Switching on input supply L1, L2, L3 (power-ups) ≥125 hp [90 kW]	maximum 1 time/2 min.
Environment according to EN60664-1	overvoltage category III/pollution degree 2

The unit is suitable for use on a circuit capable of delivering not more than 100,000 RMS symmetrical Amperes, 240/500/600/ 690 V maximum.

Motor output (U, V, W):

Output voltage	0–100% of supply voltage
Output frequency (0.33–10 hp [0.25–75 kW])	FC 301: 0.2–1000Hz / FC 302: 0 - 1000Hz
Output frequency (125–1350 hp [90–1000 kW])	0–800 ¹⁾ Hz
Output frequency in flux mode (FC 302 only)	0–300Hz
Switching on output	Unlimited
Ramp times	0.01–3600 sec.

¹⁾ Voltage and power dependent

Torque characteristics:

Starting torque (Constant torque)	maximum 160% for 60 sec. ¹⁾
Starting torque	maximum 180% up to 0.5 sec. ¹⁾
Overload torque (Constant torque)	maximum 160% for 60 sec. ¹⁾
Starting torque (Variable torque)	maximum 110% for 60 sec. ¹⁾
Overload torque (Variable torque)	maximum 110% for 60 sec.

Torque rise time in (independent of fsw)	10 ms
Torque rise time in FLUX (for 5 kHz fsw)	1 ms

¹⁾ Percentage relates to the nominal torque.

²⁾ The torque response time depends on application and load but as a general rule, the torque step from 0 to reference is 4–5 x torque rise time.

Digital inputs:

Programmable digital inputs	FC 301: 4 (5) ¹⁾ / FC 302: 4 (6) ¹⁾
Terminal number	18, 19, 27 ¹⁾ , 29 ¹⁾ , 32, 33,
Logic	PNP or NPN
Voltage level	0–24V DC
Voltage level, logic '0' PNP	< 5V DC
Voltage level, logic '1' PNP	> 10V DC
Voltage level, logic '0' NPN ²⁾	> 19V DC
Voltage level, logic '1' NPN ²⁾	< 14V DC
Maximum voltage on input	28V DC

Pulse frequency range	0–110 kHz
(Duty cycle) Min. pulse width	4.5 ms
Input resistance, R_i	approx. 4 k Ω

Safe stop Terminal 37^{3, 4)} (Terminal 37 is fixed PNP logic):

Voltage level	0–24V DC
Voltage level, logic'0' PNP	< 4V DC
Voltage level, logic'1' PNP	>20V DC
Maximum voltage on input	28V DC
Nominal input current at 24V	50mA rms
Nominal input current at 20V	60mA rms
Input capacitance	400nF

All digital inputs are galvanically isolated from the supply voltage (PELV) and other high-voltage terminals.

¹⁾ Terminals 27 and 29 can also be programmed as output.

²⁾ Except safe stop input Terminal 37.

³⁾ Terminal 37 is only available in FC 302 and FC 301 A1 with Safe Stop. It can only be used as safe stop input. Terminal 37 is suitable for PL d (ISO13849-1), SIL 2 (IEC 61508) and SILCL 2 (EN 62061) and implements a safe stop function in accordance with Safe Torque Off (STO, EN 61800-5-2) and Stop Category 0 (EN 60204-1). Terminal 37 and the Safe Stop function are designed in conformance with EN 60204-1, EN 61800-5-1, EN 61800-2, EN 61800-3, and EN 954-1. For correct and safe use of the safe stop function, follow the related information and instructions in the Design Guide.

⁴⁾ When using a contactor with a DC coil inside and in combination with safe stop, it is important to provide a return path for the current from the coil when turning it off. This can be done by using a freewheel diode (or, alternatively, a 30 or 50 V MOV for quicker response time) across the coil. Typical contactors can be bought with this diode.

Analog inputs:

Number of analog inputs	2
Terminal number	53, 54
Modes	Voltage or current
Mode select	Switch S201 and switch S202
Voltage mode	Switch S201/switch S202 = OFF (U)
Voltage level	FC 301: 0–+10/ FC 302: -10–+10 V (scaleable)
Input resistance, R_i	approx. 10 k Ω
Max. voltage	\pm 20 V
Current mode	Switch S201/switch S202 = ON (I)
Current level	0/4 to 20 mA (scaleable)
Input resistance, R_i	approx. 200 Ω
Max. current	30 mA
Resolution for analog inputs	10 bit (+ sign)
Accuracy of analog inputs	Max. error 0.5% of full scale
Bandwidth	FC 301: 20 Hz/ FC 302: 100 Hz

The analog inputs are galvanically isolated from the supply voltage (PELV) and other high-voltage terminals.

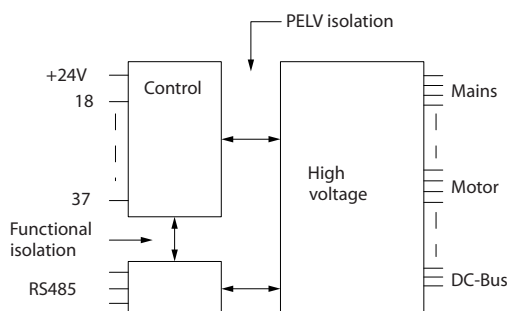

Pulse/encoder inputs:

Programmable pulse/encoder inputs	2/1
Terminal number pulse/encoder	29 ¹⁾ , 33 ²⁾ / 32 ³⁾ , 33 ³⁾
Max. frequency at terminal 29, 32, 33	110 kHz (push-pull driven)
Max. frequency at terminal 29, 32, 33	5 kHz (open collector)
Min. frequency at terminal 29, 32, 33	4 Hz
Voltage level	see section on Digital input
Maximum voltage on input	28V DC
Input resistance, R _i	approx. 4kΩ
Pulse input accuracy (0.1–1 kHz)	Max. error: 0.1% of full scale
Encoder input accuracy (1–11 kHz)	Max. error: 0.05% of full scale

The pulse and encoder inputs (terminals 29, 32, 33) are galvanically isolated from the supply voltage (PELV) and other high-voltage terminals.

¹⁾ FC 302 only

²⁾ Pulse inputs are 29 and 33

³⁾ Encoder inputs: 32 = A, and 33 = B

Digital output:

Programmable digital/pulse outputs	2
Terminal number	27, 29 ¹⁾
Voltage level at digital/frequency output	0–24V
Max. output current (sink or source)	40mA
Max. load at frequency output	1kΩ
Max. capacitive load at frequency output	10nF
Minimum output frequency at frequency output	0Hz
Maximum output frequency at frequency output	32kHz
Accuracy of frequency output	Max. error: 0.1% of full scale
Resolution of frequency outputs	12 bit

¹⁾ Terminal 27 and 29 can also be programmed as input.

The digital output is galvanically isolated from the supply voltage (PELV) and other high-voltage terminals.

Analog output:

Number of programmable analog outputs	1
Terminal number	42
Current range at analog output	0/4–20mA
Max. load GND - analog output	500Ω
Accuracy on analog output	Max. error: 0.5% of full scale
Resolution on analog output	12 bit

The analog output is galvanically isolated from the supply voltage (PELV) and other high-voltage terminals.

Control card, 24 V DC output:

Terminal number	12, 13
Output voltage	24 V +1, -3 V
Max. load	FC 301: 130 mA/ FC 302: 200 mA

The 24 V DC supply is galvanically isolated from the supply voltage (PELV), but has the same potential as the analog and digital inputs and outputs.

Control card, 10V DC output:

Terminal number	50
Output voltage	10.5V ±0.5V
Max. load	15 mA

The 10V DC supply is galvanically isolated from the supply voltage (PELV) and other high-voltage terminals.

Control card, RS-485 serial communication:

Terminal number	68 (P,TX+, RX+), 69 (N,TX-, RX-)
Terminal number 61	Common for terminals 68 and 69

The RS-485 serial communication circuit is functionally separated from other central circuits and galvanically isolated from the supply voltage (PELV).

Control card, USB serial communication:

USB standard	1.1 (Full speed)
USB plug	USB type B "device" plug

Connection to PC is carried out via a standard host/device USB cable.

The USB connection is galvanically isolated from the supply voltage (PELV) and other high-voltage terminals.

The USB ground connection is not galvanically isolated from protection ground. Use only an isolated laptop as PC connection to the USB connector on the adjustable frequency drive.

Relay outputs:

Programmable relay outputs	FC 301 all kW: 1 / FC 302 all kW: 2
Relay 01 Terminal number	1-3 (break), 1-2 (make)
Max. terminal load (AC-1) ¹⁾ on 1-3 (NC), 1-2 (NO) (Resistive load)	240V AC, 2A
Max. terminal load (AC-15) ¹⁾ (Inductive load @ cosφ 0.4)	240V AC, 0.2A
Max. terminal load (DC-1) ¹⁾ on 1-2 (NO), 1-3 (NC) (Resistive load)	60V DC, 1A
Max. terminal load (DC-13) ¹⁾ (Inductive load)	24 V DC, 0.1A
Relay 02 (FC 302 only) Terminal number	4-6 (break), 4-5 (make)
Max. terminal load (AC-1) ¹⁾ on 4-5 (NO) (Resistive load) ²⁾³⁾ Overvoltage cat. II	400V AC, 2A
Max. terminal load (AC-15) ¹⁾ on 4-5 (NO) (Inductive load @ cosφ 0.4)	240V AC, 0.2A
Max. terminal load (DC-1) ¹⁾ on 4-5 (NO) (Resistive load)	80V DC, 2A
Max. terminal load (DC-13) ¹⁾ on 4-5 (NO) (Inductive load)	24 V DC, 0.1A
Max. terminal load (AC-1) ¹⁾ on 4-6 (NC) (Resistive load)	240V AC, 2A
Max. terminal load (AC-15) ¹⁾ on 4-6 (NC) (Inductive load @ cosφ 0.4)	240V AC, 0.2A
Max. terminal load (DC-1) ¹⁾ on 4-6 (NC) (Resistive load)	50V DC, 2A
Max. terminal load (DC-13) ¹⁾ on 4-6 (NC) (Inductive load)	24 V DC, 0.1A
Min. terminal load on 1-3 (NC), 1-2 (NO), 4-6 (NC), 4-5 (NO)	24V DC 10mA, 24V AC 20mA
Environment according to EN 60664-1	overvoltage category III/pollution degree 2

¹⁾ IEC 60947 part 4 and 5

The relay contacts are galvanically isolated from the rest of the circuit by reinforced isolation (PELV).

²⁾ Overvoltage Category II

³⁾ UL applications 300V AC2A

Cable lengths and cross-sections for control cables¹⁾:

Max. motor cable length, shielded	FC 301: 164 ft [50 m]/FC 301 (A1): 82 ft [25 m]/ FC 302: 492 ft [150 m]
Max. motor cable length, non-shielded	FC 301: 246 ft [75 m]/FC 301 (A1): 164 ft [50 m]/ FC 302: 984 ft [300 m]
Maximum cross-section to control terminals, flexible/ rigid wire without cable end sleeves	0.0023 in ² [1.5mm ²]/ 16 AWG
Maximum cross-section to control terminals, flexible wire with cable end sleeves	0.0016 in ² [1 mm ²]/ 18 AWG
Maximum cross-section to control terminals, flexible wire with cable end sleeves with collar	0.0008 in ² [0.5mm ²]/ 20 AWG
Minimum cross-section to control terminals	0.00039 in ² [0.25mm ²]/ 24AWG

¹⁾Power cables, see tables in 10.1 Power-dependent Specifications.

Control card performance:

Scan interval	FC 301: 5 ms / FC 302: 1 ms
---------------	-----------------------------

Control characteristics:

Resolution of output frequency at 0–1000Hz	± 0.003Hz
Repeat accuracy of <i>Precise start/stop</i> (terminals 18, 19)	≤± 0.1msec
System response time (terminals 18, 19, 27, 29, 32, 33)	≤ 2ms
Speed control range (open-loop)	1:100 of synchronous speed
Speed control range (closed-loop)	1:1000 of synchronous speed

Specifications **VLT® Automation Drive Instruction Manual**

Speed accuracy (open-loop)	30–4000 rpm: error ±8rpm
Speed accuracy (closed-loop), depending on resolution of feedback device	0–6000 rpm: error ±0.15 rpm
Torque control accuracy (speed feedback)	max error ±5% of rated torque

All control characteristics are based on a 4-pole asynchronous motor

Environment:

Enclosure	IP20 ¹⁾ / Type 1, IP21 ²⁾ / Type 1, IP55/ Type 12, IP 66
Vibration test	1.0g
Max. relative humidity	5%–93% (IEC 721-3-3; Class 3K3 (non-condensing) during operation
Aggressive environment (IEC 60068-2-43) H ₂ S test	class Kd
Ambient temperature ³⁾	Max. 122°F [50°C] (24-hour average maximum 113°F [45°C])

¹⁾ Only for ≤ 5 hp [3.7 kW] (200–240V), ≤ 10 hp [7.5 kW] (400–480/ 500V)

²⁾ As enclosure kit for ≤ 5 hp [3.7 kW] (200–240V), ≤ 10 hp [7.5 kW] (400–480/ 500V)

³⁾ Derating for high ambient temperature, see special conditions in the Design Guide

Minimum ambient temperature during full-scale operation	32°F [0°C]
Minimum ambient temperature at reduced performance	14°F [-10°C]
Temperature during storage/transport	-13°–149°/158°F [-25°–+65°/70°C]
Maximum altitude above sea level without derating	3280 ft [1000 m]

Derating for high altitude, see special conditions in the Design Guide.

EMC standards, Emission	EN 61800-3, EN 61000-6-3/4, EN 55011
EMC standards, Immunity	EN 61800-3, EN 61000-6-1/2, EN 61000-4-2, EN 61000-4-3, EN 61000-4-4, EN 61000-4-5, EN 61000-4-6

See section on special conditions in the Design Guide.

Protection and Features:

- Electronic thermal motor protection against overload.
- Temperature monitoring of the heatsink ensures that the adjustable frequency drive trips if the temperature reaches a predefined level. An overload temperature cannot be reset until the temperature of the heatsink is below the values stated in the tables on the following pages (guideline - these temperatures may vary for different power sizes, frame sizes, enclosure ratings, etc.).
- The adjustable frequency drive is protected against short-circuits on motor terminals U, V, W.
- If a line phase is missing, the adjustable frequency drive trips or issues a warning (depending on the load).
- Monitoring of the intermediate circuit voltage ensures that the adjustable frequency drive trips if the intermediate circuit voltage is too low or too high.
- The adjustable frequency drive constantly checks for critical levels of internal temperature, load current, high voltage on the intermediate circuit and low motor speeds. As a response to a critical level, the adjustable frequency drive can adjust the switching frequency and/or change the switching pattern in order to ensure the performance of the adjustable frequency drive.

10.3 Fuse Tables

It is recommended to use fuses and/or circuit breakers on the supply side as protection in case of component breakdown inside the adjustable frequency drive (first fault).

NOTE!

This is mandatory in order to ensure compliance with IEC 60364 for CE or NEC 2009 for UL.

⚠ WARNING

Personnel and property must be protected against the consequence of component breakdown internally in the adjustable frequency drive.

Branch Circuit Protection

In order to protect the installation against electrical and fire hazard, all branch circuits in an installation, switch gear, machines etc., must be protected against short-circuit and overcurrent according to national/international regulations.

NOTE!

The recommendations given do not cover branch circuit protection for UL!

10

Short-circuit protection:

Danfoss recommends using the fuses/circuit breakers mentioned below to protect service personnel and property in case of component breakdown in the adjustable frequency drive.

Overcurrent protection:

The adjustable frequency drive provides overload protection to limit threats to human life, property damage and to avoid fire hazard due to overheating of the cables in the installation. The adjustable frequency drive is equipped with an internal overcurrent protection (*4-18 Current Limit*) that can be used for upstream overload protection (UL applications excluded). Moreover, fuses or circuit breakers can be used to provide the overcurrent protection in the installation. Overcurrent protection must always be carried out according to national regulations.

10.3.1 Recommendations

⚠ WARNING

In case of malfunction, not following the recommendation may result in personnel risk and damage to the adjustable frequency drive and other equipment.

The following tables list the recommended rated current. Recommended fuses are of the type gG for small to medium power sizes. For larger powers, aR fuses are recommended. For circuit breakers, Moeller types have been tested to have a recommendation. Other types of circuit breakers may be used provide they limit the energy into the Adjustable frequency drive to a level equal to or lower than the Moeller types.

If fuses/circuit breakers according to recommendations are chosen, possible damage to the adjustable frequency drive will mainly be limited to damage inside the unit.

For further information, please see Application Note *Fuses and Circuit Breakers*, MN.90.TX.YY

10.3.2 CE Compliance

Fuses or circuit breakers are mandatory to comply with IEC 60364. Danfoss recommend using a selection of the following.

The fuses below are suitable for use on a circuit capable of delivering 100,000 Arms (symmetrical), 240V, or 480V, or 500V, or 600V depending on the Adjustable frequency drive voltage rating. With the proper fusing, the Adjustable frequency drive short circuit current rating (SCCR) is 100,000 Arms.

Enclosure	FC 300 Power	Recommended fuse size	Recommended Max. fuse	Recommended circuit breaker	Max. trip level
Size	[kW]			Moeller	[A]
A1	0.25–1.5	gG-10	gG-25	PKZM0-16	16
A2	0.25–2.2	gG-10 (0.25–1.5) gG-16 (2.2)	gG-25	PKZM0-25	25
A3	3.0–3.7	gG-16 (3) gG-20 (3.7)	gG-32	PKZM0-25	25
B3	5.5	gG-25	gG-63	PKZM4-50	50
B4	7.5–1.5	gG-32 (7.5) gG-50 (11) gG-63 (15)	gG-125	NZMB1-A100	100
C3	18.5–22	gG-80 (18.5) aR-125 (22)	gG-150 (18.5) aR-160 (22)	NZMB2-A200	150
C4	30–37	aR-160 (30) aR-200 (37)	aR-200 (30) aR-250 (37)	NZMB2-A250	250
A4	0.25–2.2	gG-10 (0.25–1.5) gG-16 (2.2)	gG-32	PKZM0-25	25
A5	0.25–3.7	gG-10 (0.25–1.5) gG-16 (2.2–3) gG-20 (3.7)	gG-32	PKZM0-25	25
B1	5.5–7.5	gG-25 (5.5) gG-32 (7.5)	gG-80	PKZM4-63	63
B2	11	gG-50	gG-100	NZMB1-A100	100
C1	15–22	gG-63 (15) gG-80 (18.5) gG-100 (22)	gG-160 (15–18.5) aR-160 (22)	NZMB2-A200	160
C2	30–37	aR-160 (30) aR-200 (37)	aR-200 (30) aR-250 (37)	NZMB2-A250	250

Table 10.1 200–240V, Frame Sizes A, B, and C

Enclosure	FC 300 Power	Recommended fuse size	Recommended Max. fuse	Recommended circuit breaker	Max. trip level
Size	[kW]			Moeller	[A]
A1	0.37–1.5	gG-10	gG-25	PKZM0-16	16
A2	0.37–4.0	gG-10 (0.37–3) gG-16 (4)	gG-25	PKZM0-25	25
A3	5.5–7.5	gG-16	gG-32	PKZM0-25	25
B3	11–15	gG-40	gG-63	PKZM4-50	50
B4	18.5–30	gG-50 (18.5) gG-63 (22) gG-80 (30)	gG-125	NZMB1-A100	100
C3	37–45	gG-100 (37) gG-160 (45)	gG-150 (37) gG-160 (45)	NZMB2-A200	150
C4	55–75	aR-200 (55) aR-250 (75)	aR-250	NZMB2-A250	250
A4	0.37–4	gG-10 (0.37–3) gG-16 (4)	gG-32	PKZM0-25	25
A5	0.37–7.5	gG-10 (0.37–3) gG-16 (4–7.5)	gG-32	PKZM0-25	25
B1	11–15	gG-40	gG-80	PKZM4-63	63
B2	18.5–22	gG-50 (18.5) gG-63 (22)	gG-100	NZMB1-A100	100
C1	30–45	gG-80 (30) gG-100 (37) gG-160 (45)	gG-160	NZMB2-A200	160
C2	55–75	aR-200 (55) aR-250 (75)	aR-250	NZMB2-A250	250
D	90–200	gG-300 (90) gG-350 (110) gG-400 (132) gG-500 (160) gG-630 (200)	gG-300 (90) gG-350 (110) gG-400 (132) gG-500 (160) gG-630 (200)	-	-
E	250–400	aR-700 (250) aR-900 (315–400)	aR-700 (250) aR-900 (315–400)	-	-
F	450–800	aR-1600 (450–500) aR-2000 (560–630) aR-2500 (710–800)	aR-1600 (450–500) aR-2000 (7560–630) aR-2500 (710–800)	-	-

Table 10.2 380–500V, Frame Sizes A, B, C, D, E, and F

Specifications **VLT® Automation Drive Instruction Manual**

Enclosure	FC 300 Power	Recommended fuse size	Recommended Max. fuse	Recommended circuit breaker	Max. trip level
Size	[kW]			Moeller	[A]
A2	0.75–4.0	gG-10	gG-25	PKZM0-25	25
A3	5.5–7.5	gG-10 (5.5) gG-16 (7.5)	gG-32	PKZM0-25	25
B3	11–15	gG-25 (11) gG-32 (15)	gG-63	PKZM4-50	50
B4	18.5–30	gG-40 (18.5) gG-50 (22) gG-63 (30)	gG-125	NZMB1-A100	100
C3	37–45	gG-63 (37) gG-100 (45)	gG-150	NZMB2-A200	150
C4	55–75	aR-160 (55) aR-200 (75)	aR-250	NZMB2-A250	250
A5	0.75–7.5	gG-10 (0.75–5.5) gG-16 (7.5)	gG-32	PKZM0-25	25
B1	11–18	gG-25 (11) gG-32 (15) gG-40 (18.5)	gG-80	PKZM4-63	63
B2	22–30	gG-50 (22) gG-63 (30)	gG-100	NZMB1-A100	100
C1	37–55	gG-63 (37) gG-100 (45) aR-160 (55)	gG-160 (37–45) aR-250 (55)	NZMB2-A200	160
C2	75	aR-200 (75)	aR-250	NZMB2-A250	250

Table 10.3 525–600V, Frame Sizes A, B, and C

Specifications VLT® Automation Drive Instruction
Manual

Enclosure	FC 300 Power	Recommended fuse size	Recommended Max. fuse	Recommended circuit breaker	Max. trip level
Size	[kW]			Moeller	[A]
B2	11	gG-25 (11)	gG-63	-	-
	15	gG-32 (15)			
	18	gG-32 (18)			
	22	gG-40 (22)			
C2	30	gG-63 (30)	gG-80 (30)	-	-
	37	gG-63 (37)	gG-100 (37)		
	45	gG-80 (45)	gG-125 (45)		
	55	gG-100 (55)	gG-160 (55-75)		
	75	gG-125 (75)			
D	37-315	gG-125 (37)	gG-125 (37)	-	-
		gG-160 (45)	gG-160 (45)		
		gG-200 (55-75)	gG-200 (55-75)		
		aR-250 (90)	aR-250 (90)		
		aR-315 (110)	aR-315 (110)		
		aR-350 (132-160)	aR-350 (132-160)		
		aR-400 (200)	aR-400 (200)		
aR-500 (250)	aR-500 (250)				
aR-550 (315)	aR-550 (315)				
E	355-560	aR-700 (355-400)	aR-700 (355-400)	-	-
		aR-900 (500-560)	aR-900 (500-560)		
F	630-1200	aR-1600 (630-900)	aR-1600 (630-900)	-	-
		aR-2000 (1000)	aR-2000 (1000)		
		aR-2500 (1200)	aR-2500 (1200)		

Table 10.4 525-690V, Frame Sizes B, C, D, E, and F

UL Compliance

Fuses or circuit breakers are mandatory to comply with NEC 2009. We recommend using a selection of the following.

The fuses below are suitable for use on a circuit capable of delivering 100,000 Arms (symmetrical), 240V, or 480V, or 500V, or 600V depending on the Adjustable frequency drive voltage rating. With the proper fusing, the drive Short Circuit Current Rating (SCCR) is 100,000 Arms.

FC 300 Power	Recommended max. fuse					
	Bussmann	Bussmann	Bussmann	Bussmann	Bussmann	Bussmann
[kW]	Type RK1 ¹⁾	Type J	Type T	Type CC	Type CC	Type CC
0.25–0.37	KTN-R-05	JKS-05	JJN-05	FNQ-R-5	KTK-R-5	LP-CC-5
0.55–1.1	KTN-R-10	JKS-10	JJN-10	FNQ-R-10	KTK-R-10	LP-CC-10
1.5	KTN-R-15	JKS-15	JJN-15	FNQ-R-15	KTK-R-15	LP-CC-15
2.2	KTN-R-20	JKS-20	JJN-20	FNQ-R-20	KTK-R-20	LP-CC-20
3.0	KTN-R-25	JKS-25	JJN-25	FNQ-R-25	KTK-R-25	LP-CC-25
3.7	KTN-R-30	JKS-30	JJN-30	FNQ-R-30	KTK-R-30	LP-CC-30
5.5	KTN-R-50	KS-50	JJN-50	-	-	-
7.5	KTN-R-60	JKS-60	JJN-60	-	-	-
11	KTN-R-80	JKS-80	JJN-80	-	-	-
15–18.5	KTN-R-125	JKS-125	JJN-125	-	-	-
30 [22]	KTN-R-150	JKS-150	JJN-150	-	-	-
40 [30]	KTN-R-200	JKS-200	JJN-200	-	-	-
37	KTN-R-250	JKS-250	JJN-250	-	-	-

Table 10.5 200–240V, Frame Sizes A, B, and C

FC 300 Power	Recommended max. fuse			
	SIBA	Littel fuse	Ferraz-Shawmut	Ferraz-Shawmut
[kW]	Type RK1	Type RK1	Type CC	Type RK1 ³⁾
0.25–0.37	5017906-005	KLN-R-05	ATM-R-05	A2K-05-R
0.55–1.1	5017906-010	KLN-R-10	ATM-R-10	A2K-10-R
1.5	5017906-016	KLN-R-15	ATM-R-15	A2K-15-R
2.2	5017906-020	KLN-R-20	ATM-R-20	A2K-20-R
3.0	5017906-025	KLN-R-25	ATM-R-25	A2K-25-R
3.7	5012406-032	KLN-R-30	ATM-R-30	A2K-30-R
5.5	5014006-050	KLN-R-50	-	A2K-50-R
7.5	5014006-063	KLN-R-60	-	A2K-60-R
11	5014006-080	KLN-R-80	-	A2K-80-R
15–18.5	2028220-125	KLN-R-125	-	A2K-125-R
22	2028220-150	KLN-R-150	-	A2K-150-R
30	2028220-200	KLN-R-200	-	A2K-200-R
37	2028220-250	KLN-R-250	-	A2K-250-R

Table 10.6 200–240V, Frame Sizes A, B, and C

FC 300	Recommended max. fuse			
	Bussmann	Littel fuse	Ferraz-Shawmut	Ferraz-Shawmut
[kW]	Type JFHR2 ²⁾	JFHR2	JFHR2 ⁴⁾	J
0.25–0.37	FWX-5	-	-	HSJ-6
0.55–1.1	FWX-10	-	-	HSJ-10
1.5	FWX-15	-	-	HSJ-15
2.2	FWX-20	-	-	HSJ-20
3.0	FWX-25	-	-	HSJ-25
3.7	FWX-30	-	-	HSJ-30
5.5	FWX-50	-	-	HSJ-50
7.5	FWX-60	-	-	HSJ-60
11	FWX-80	-	-	HSJ-80
15–18.5	FWX-125	-	-	HSJ-125
22	FWX-150	L25S-150	A25X-150	HSJ-150
30	FWX-200	L25S-200	A25X-200	HSJ-200
37	FWX-250	L25S-250	A25X-250	HSJ-250

Table 10.7 200–240V, Frame Sizes A, B, and C

- 1) KTS fuses from Bussmann may substitute KTN for 240V adjustable frequency drives.
- 2) FWH fuses from Bussmann may substitute FWX for 240V adjustable frequency drives.
- 3) A6KR fuses from FERRAZ SHAWMUT may substitute A2KR for 240V adjustable frequency drives.
- 4) A50X fuses from FERRAZ SHAWMUT may substitute A25X for 240V adjustable frequency drives.

10

FC 300	Recommended max. fuse					
	Bussmann	Bussmann	Bussmann	Bussmann	Bussmann	Bussmann
[kW]	Type RK1	Type J	Type T	Type CC	Type CC	Type CC
0.37–1.1	KTS-R-6	JKS-6	JJS-6	FNQ-R-6	KTK-R-6	LP-CC-6
1.5–2.2	KTS-R-10	JKS-10	JJS-10	FNQ-R-10	KTK-R-10	LP-CC-10
3	KTS-R-15	JKS-15	JJS-15	FNQ-R-15	KTK-R-15	LP-CC-15
4	KTS-R-20	JKS-20	JJS-20	FNQ-R-20	KTK-R-20	LP-CC-20
5.5	KTS-R-25	JKS-25	JJS-25	FNQ-R-25	KTK-R-25	LP-CC-25
7.5	KTS-R-30	JKS-30	JJS-30	FNQ-R-30	KTK-R-30	LP-CC-30
11	KTS-R-40	JKS-40	JJS-40	-	-	-
15	KTS-R-50	JKS-50	JJS-50	-	-	-
18	KTS-R-60	JKS-60	JJS-60	-	-	-
22	KTS-R-80	JKS-80	JJS-80	-	-	-
30	KTS-R-100	JKS-100	JJS-100	-	-	-
37	KTS-R-125	JKS-125	JJS-125	-	-	-
45	KTS-R-150	JKS-150	JJS-150	-	-	-
55	KTS-R-200	JKS-200	JJS-200	-	-	-
75	KTS-R-250	JKS-250	JJS-250	-	-	-

Table 10.8 380–500V, Frame Sizes A, B, and C

FC 302	Recommended max. fuse			
	SIBA	Littel fuse	Ferraz-Shawmut	Ferraz-Shawmut
[kW]	Type RK1	Type RK1	Type CC	Type RK1
0.37–1.1	5017906-006	KLS-R-6	ATM-R-6	A6K-6-R
1.5–2.2	5017906-010	KLS-R-10	ATM-R-10	A6K-10-R
3	5017906-016	KLS-R-15	ATM-R-15	A6K-15-R
4	5017906-020	KLS-R-20	ATM-R-20	A6K-20-R
5.5	5017906-025	KLS-R-25	ATM-R-25	A6K-25-R
7.5	5012406-032	KLS-R-30	ATM-R-30	A6K-30-R
11	5014006-040	KLS-R-40	-	A6K-40-R
15	5014006-050	KLS-R-50	-	A6K-50-R
18	5014006-063	KLS-R-60	-	A6K-60-R
22	2028220-100	KLS-R-80	-	A6K-80-R
30	2028220-125	KLS-R-100	-	A6K-100-R
37	2028220-125	KLS-R-125	-	A6K-125-R
45	2028220-160	KLS-R-150	-	A6K-150-R
55	2028220-200	KLS-R-200	-	A6K-200-R
75	2028220-250	KLS-R-250	-	A6K-250-R

Table 10.9 380–500V, Frame Sizes A, B, and C

FC 302	Recommended max. fuse			
	Bussmann	Ferraz-Shawmut	Ferraz-Shawmut	Littel fuse
[kW]	JFHR2	J	JFHR2 ¹⁾	JFHR2
0.37–1.1	FWH-6	HSJ-6	-	-
1.5–2.2	FWH-10	HSJ-10	-	-
3	FWH-15	HSJ-15	-	-
4	FWH-20	HSJ-20	-	-
5.5	FWH-25	HSJ-25	-	-
7.5	FWH-30	HSJ-30	-	-
11	FWH-40	HSJ-40	-	-
15	FWH-50	HSJ-50	-	-
18	FWH-60	HSJ-60	-	-
22	FWH-80	HSJ-80	-	-
30	FWH-100	HSJ-100	-	-
37	FWH-125	HSJ-125	-	-
45	FWH-150	HSJ-150	-	-
55	FWH-200	HSJ-200	A50-P-225	L50-S-225
75	FWH-250	HSJ-250	A50-P-250	L50-S-250

Table 10.10 380–500V, Frame Sizes A, B, and C

1) Ferraz-Shawmut A50QS fuses may substitute for A50P fuses.

FC 302	Recommended max. fuse					
	Bussmann	Bussmann	Bussmann	Bussmann	Bussmann	Bussmann
[kW]	Type RK1	Type J	Type T	Type CC	Type CC	Type CC
0.75–1.1	KTS-R-5	JKS-5	JJS-6	FNQ-R-5	KTK-R-5	LP-CC-5
1.5–2.2	KTS-R-10	JKS-10	JJS-10	FNQ-R-10	KTK-R-10	LP-CC-10
3	KTS-R-15	JKS-15	JJS-15	FNQ-R-15	KTK-R-15	LP-CC-15
4	KTS-R-20	JKS-20	JJS-20	FNQ-R-20	KTK-R-20	LP-CC-20
5.5	KTS-R-25	JKS-25	JJS-25	FNQ-R-25	KTK-R-25	LP-CC-25
7.5	KTS-R-30	JKS-30	JJS-30	FNQ-R-30	KTK-R-30	LP-CC-30
11	KTS-R-35	JKS-35	JJS-35	-	-	-
15	KTS-R-45	JKS-45	JJS-45	-	-	-
18	KTS-R-50	JKS-50	JJS-50	-	-	-
22	KTS-R-60	JKS-60	JJS-60	-	-	-
30	KTS-R-80	JKS-80	JJS-80	-	-	-
37	KTS-R-100	JKS-100	JJS-100	-	-	-
45	KTS-R-125	JKS-125	JJS-125	-	-	-
55	KTS-R-150	JKS-150	JJS-150	-	-	-
75	KTS-R-175	JKS-175	JJS-175	-	-	-

Table 10.11 525–600V, Frame Sizes A, B, and C

FC 302	Recommended max. fuse			
	SIBA	Littel fuse	Ferraz-Shawmut	Ferraz-Shawmut
[kW]	Type RK1	Type RK1	Type RK1	J
0.75–1.1	5017906-005	KLS-R-005	A6K-5-R	HSJ-6
1.5–2.2	5017906-010	KLS-R-010	A6K-10-R	HSJ-10
3	5017906-016	KLS-R-015	A6K-15-R	HSJ-15
4	5017906-020	KLS-R-020	A6K-20-R	HSJ-20
5.5	5017906-025	KLS-R-025	A6K-25-R	HSJ-25
7.5	5017906-030	KLS-R-030	A6K-30-R	HSJ-30
11	5014006-040	KLS-R-035	A6K-35-R	HSJ-35
15	5014006-050	KLS-R-045	A6K-45-R	HSJ-45
18	5014006-050	KLS-R-050	A6K-50-R	HSJ-50
22	5014006-063	KLS-R-060	A6K-60-R	HSJ-60
30	5014006-080	KLS-R-075	A6K-80-R	HSJ-80
37	5014006-100	KLS-R-100	A6K-100-R	HSJ-100
45	2028220-125	KLS-R-125	A6K-125-R	HSJ-125
55	2028220-150	KLS-R-150	A6K-150-R	HSJ-150
75	2028220-200	KLS-R-175	A6K-175-R	HSJ-175

Table 10.12 525–600V, Frame Sizes A, B, and C

¹⁾ 170M fuses shown from Bussmann use the -/80 visual indicator. –TN/80 Type T, -/110 or TN/110 Type T indicator fuses of the same size and amperage may be substituted.

FC 302 [kW]	Recommended max. fuse							
	Max. prefuse	Bussmann E52273 RK1/JDDZ	Bussmann E4273 J/JDDZ	Bussmann E4273 T/JDDZ	SIBA E180276 RK1/JDDZ	Littelfuse E81895 RK1/JDDZ	Ferraz-Shawmut E163267/E2137 RK1/JDDZ	Ferraz-Shawmut E2137 J/H SJ
11	30 A	KTS-R-30	JKS-30	JKJS-30	5017906-030	KLS-R-030	A6K-30-R	HST-30
15–18.5	45 A	KTS-R-45	JKS-45	JJS-45	5014006-050	KLS-R-045	A6K-45-R	HST-45
22	60 A	KTS-R-60	JKS-60	JJS-60	5014006-063	KLS-R-060	A6K-60-R	HST-60
30	80 A	KTS-R-80	JKS-80	JJS-80	5014006-080	KLS-R-075	A6K-80-R	HST-80
37	90 A	KTS-R-90	JKS-90	JJS-90	5014006-100	KLS-R-090	A6K-90-R	HST-90
45	100 A	KTS-R-100	JKS-100	JJS-100	5014006-100	KLS-R-100	A6K-100-R	HST-100
55	125 A	KTS-R-125	JKS-125	JJS-125	2028220-125	KLS-150	A6K-125-R	HST-125
75	150 A	KTS-R-150	JKS-150	JJS-150	2028220-150	KLS-175	A6K-150-R	HST-150

* UL compliance only 525–600 V

Table 10.13 525–690V*, Frame Sizes B and C

10.4 Connection Tightening Torques

Enclosure	Power (kW)			Torque (Nm)						
	200–240V	380–480/500V	525–600V	525–690V	Line power	Motor	DC connection	Brake	Ground	Relay
A2	0.25–2.2	0.37–4.0			1.8	1.8	1.8	1.8	3	0.6
A3	3.0–3.7	5.5–7.5	0.75–7.5		1.8	1.8	1.8	1.8	3	0.6
A4	0.25–2.2	0.37–4.0			1.8	1.8	1.8	1.8	3	0.6
A5	0.25–3.7	0.37–7.5	0.75–7.5		1.8	1.8	1.8	1.8	3	0.6
B1	5.5–7.5	11–15	11–15		1.8	1.8	1.5	1.5	3	0.6
B2	11	18	18	11	4.5	4.5	3.7	3.7	3	0.6
		22	22	22	4.5	4.5	3.7	3.7	3	0.6
B3	5.5–7.5	11–15	11–15		1.8	1.8	1.8	1.8	3	0.6
B4	11–15	18–30	18–30		4.5	4.5	4.5	4.5	3	0.6
C1	15–22	30–45	30–45		10	10	10	10	3	0.6
C2	30–37	55–75	55–75	30–75	14/24 ¹⁾	14/24 ¹⁾	14	14	3	0.6
C3	18–22	37–45	37–45		10	10	10	10	3	0.6
C4	30–37	55–75	55–75		14/24 ¹⁾	14/24 ¹⁾	14	14	3	0.6

Table 10.14 Tightening of Terminals

¹⁾ For different cable dimensions x/y, where $x \leq 0.147 \text{ in}^2 [95 \text{ mm}^2]$ and $y \geq 0.147 \text{ in}^2 [95 \text{ mm}^2]$.

Index

A

A53.....	2-10
A54.....	2-10

AC

Input.....	1-4, 2-7
Line.....	1-4
Line Power.....	1-3, 2-7
Line Voltage.....	4-2, 4-3, 7-2, 8-8
Waveform.....	1-3, 1-4

Alarm Log.....	4-4, 4-2
----------------	----------

Alarms.....	8-1
-------------	-----

AMA

With T27 Connected.....	6-1
Without T27 Connected.....	6-1

Analog

Inputs.....	2-8, 8-4, 10-12
Output.....	2-8, 10-13

Application Examples.....	6-1
---------------------------	-----

Approvals.....	0-1
----------------	-----

Auto

Mode.....	4-2
On.....	4-3, 7-1, 7-3

Automatic Motor Adaptation.....	3-4, 7-1
---------------------------------	----------

Auto-reset.....	4-1
-----------------	-----

B

Backplate.....	2-2
----------------	-----

Braking.....	8-7, 7-1
--------------	----------

Branch Circuit Protection.....	10-16
--------------------------------	-------

C

Cable Lengths And Cross-sections.....	10-14
---------------------------------------	-------

Circuit Breakers.....	3-2
-----------------------	-----

Clearance

Clearance.....	8-7, 2-1
Requirements.....	2-1

Closed-loop.....	2-10
------------------	------

Communication Option.....	8-7
---------------------------	-----

Conduit.....	2-5, 3-2
--------------	----------

Control

Cables.....	2-10
Card Performance.....	10-14
Card, +10V DC Output.....	10-13
Card, 24 V DC Output.....	10-13
Card, RS-485 Serial Communication.....	10-14
Card, USB Serial Communication.....	10-14
Characteristics.....	10-14
Signal.....	5-1, 5-2, 7-1
System.....	1-3
Terminals.....	2-3, 3-4, 4-3, 7-1, 7-3, 5-2, 2-9
Wire.....	2-9
Wiring.....	2-5, 2-6, 2-9, 3-2, 2-7

Cooling

Cooling.....	2-1
Clearance.....	3-2

Copying Parameter Settings.....	4-3
---------------------------------	-----

Current

Limit.....	3-5, 8-6
Rating.....	2-1, 8-5

D

Danfoss FC.....	2-15
-----------------	------

DC

Current.....	1-4, 7-2
Link.....	8-5

Derating.....	8-5, 2-1
---------------	----------

Digital

Input.....	7-3, 8-6, 2-10
Inputs.....	2-8, 7-3
Inputs.....	10-11
Output.....	10-13

Disconnect

Switch.....	3-3
Switches.....	3-1

E

Electrical Noise.....	2-6
-----------------------	-----

EMC.....	3-2, 8-6
----------	----------

Encoder Rotation.....	3-5
-----------------------	-----

External

Commands.....	1-4, 7-1
Controllers.....	1-3
Interlock.....	2-10, 5-3
Voltage.....	5-1

F

Fault

Log.....	4-2, 4-4
Messages.....	8-4

Feedback.....	2-10, 3-2, 8-8, 7-2, 8-11
---------------	---------------------------

Floating Delta.....	2-7
---------------------	-----

Full Load Current.....	2-1
------------------------	-----

Functional Testing	1-2, 3-6, 3-1		
Fuses	3-2, 8-7, 9-1, 10-16		
Fusing	2-5, 3-2		
G			
Ground			
Connections.....	2-6, 3-2		
Loops.....	2-10		
Wire.....	2-6, 3-2		
Grounded Delta	2-7		
Grounding			
Grounding.....	2-6, 2-7, 3-1, 3-2		
Using Shielded Cable.....	2-6		
H			
Hand On	3-5, 4-3, 7-1		
Harmonics	1-4		
I			
IEC 61800-3	2-7		
Induced Voltage	2-5		
Initialization	4-4		
Input			
Current.....	2-7		
Disconnect.....	2-7		
Power.....	2-5, 2-6, 2-7, 3-2, 8-1, 1-4, 3-1		
Signal.....	5-1		
Signals.....	2-10		
Terminals.....	2-3, 2-7, 2-10, 3-1, 8-4		
Voltage.....	3-3, 8-1, 8-5		
Installation	1-2, 2-1, 2-2, 2-5, 2-9, 2-15, 3-2, 8-6, 3-3		
Isolated Line Power	2-7		
L			
Leakage			
Current.....	3-1, 2-6		
Current (>3.5mA).....	2-6		
Lifting	2-2		
Line			
Power.....	2-5		
Power Supply.....	10-1, 10-6, 10-7, 10-8		
Power Supply (L1, L2, L3).....	10-11		
Voltage.....	8-5		
Local			
Control.....	4-1, 4-3, 7-1		
Control Panel.....	4-1		
Control Test.....	3-5		
Mode.....	3-5		
Operation.....	4-1		
Start.....	3-5		
M			
Main Menu	4-2, 5-1, 4-2		
Manual Initialization	4-4		
Mechanical Brake Control	2-14		
Menu			
Keys.....	4-1, 4-2		
Structure.....	4-3, 5-4		
Modbus RTU	2-15		
Motor			
Cables.....	2-1, 2-5, 2-6		
Current.....	1-4, 8-5, 8-9, 4-2		
Data.....	3-4, 3-5, 4-4, 8-6, 8-5, 8-9, 3-4		
Leads.....	8-6		
Output.....	10-11		
Power.....	2-3, 2-5, 2-6, 8-9		
Protection.....	2-5, 10-15		
Rotation.....	3-5, 4-2		
Speeds.....	3-3		
Status.....	1-3		
Wiring.....	2-5, 2-6		
Wiring, And.....	3-2		
Mounting	2-2		
Multiple			
Adjustable Frequency Drives.....	2-5, 2-6		
Motors.....	3-1		
N			
Navigation Keys	3-3, 5-1, 4-3		
Noise Isolation	2-5, 3-2		
O			
Open-loop	2-10, 5-1		
Operation Keys	4-3		
Optional Equipment	2-7, 2-10, 3-3		
Output			
Current.....	7-2, 8-5		
Performance (U, V, W).....	10-11		
Signal.....	5-4		
Terminals.....	2-3, 3-1		
Overcurrent	7-2		
Overload Protection	2-1, 2-5		
Overvoltage	3-6, 7-2		
P			
PELV	2-7, 6-4		
Power			
Connections.....	2-5		
Factor.....	1-4, 2-6, 3-2		
Power-dependent	10-1		

Pre-start	3-1	Surroundings	10-15
Programming		Switching Frequency	7-2, 8-5
Programming... 1-2, 2-10, 3-6, 4-2, 4-4, 5-3, 5-4, 5-9, 8-4, 3-3,		Symbols	0-1
4-1, 4-3, 5-1		System	
Example.....	5-1	Feedback.....	1-3
Protection And Features	10-15	Monitoring.....	8-1
Pulse/Encoder Inputs	10-13	Start-up.....	3-6
Q		T	
Quick		Technical Data	10-11
Menu.....	5-1, 5-3, 4-2	Temperature Limits	3-2
Set-up.....	3-4	Terminal	
 		53.....	5-1, 2-10, 5-1
R		54.....	2-10
Ramp-down Time	3-6	Programming.....	2-10
Ramp-up Time	3-5	Programming Examples.....	5-2
RCD	2-6	Thermistor	
Reference	0-1, 7-2, 7-3, 4-2	Thermistor.....	2-7, 8-5, 6-4
Relay Outputs	2-8, 10-14	Control Wiring.....	2-7
Remote		Tightening Of Terminals	10-25
Commands.....	1-3	Torque	
Programming.....	5-9	Characteristics.....	10-11
Reference.....	7-2	Limit.....	3-5
Reset	4-1, 4-4, 7-3, 8-1, 8-5, 8-7, 8-10, 4-3	Transient Protection	1-4
RFI Filter	2-7	Trip	
RMS Current	1-4	Trip.....	8-1
Run		Function.....	2-5
Command.....	3-6	Lock.....	8-1
Permissive.....	7-2	Troubleshooting	1-2, 8-4, 9-1
S		V	
Safety Inspection	3-1	Voltage Level	10-11
Serial Communication 1-3, 2-8, 2-9, 4-3, 4-4, 7-1, 7-2, 7-3, 8-			
6, 8-1, 2-14		W	
Setpoint	7-3	Warning	
Set-up	3-6, 4-2	And Alarm Definitions.....	8-2
Shielded		And Alarm Displays.....	8-1
Cable.....	2-1, 2-5, 3-2	And Alarm Types.....	8-1
Control Cables.....	2-9	Warnings	8-1
Wire.....	2-5	Wire	
Specifications	1-2, 2-15, 10-1	Wire.....	2-6
Speed Reference	2-10, 3-6, 5-2, 7-1	Sizes.....	2-5, 2-6
Start Up	5-1		
Start-up	1-2, 4-4, 3-1, 3-2		
Status			
Messages.....	7-1		
Mode.....	7-1		
Stop Command	7-2		
Supply Voltage	2-7, 2-8, 3-1, 8-5, 8-7		



www.danfoss.com/drives

Danfoss shall not be responsible for any errors in catalogs, brochures or other printed material. Danfoss reserves the right to alter its products at any time without notice, provided that alterations to products already on order shall not require material changes in specifications previously agreed upon by Danfoss and the Purchaser. All trademarks in this material are property of the respective companies. Danfoss and the Danfoss logotype are trademarks of Danfoss A/S. All rights reserved.

Danfoss Drives

4401 N. Bell School Rd.
Loves Park IL 61111 USA
Phone: 1-800-432-6367
1-815-639-8600
Fax: 1-815-639-8000
www.danfossdrives.com

Danfoss Drives

8800 W. Bradley Rd.
Milwaukee, WI 53224 USA
Phone: 1-800-621-8806
1-414-355-8800
Fax: 1-414-355-6117
www.danfossdrives.com

