

## Contents

■ <b>How to Read this Design Guide</b>	5
□ How to Read this Design Guide	5
□ Approvals	6
□ Symbols	6
□ Abbreviations	7
□ Definitions	8
■ <b>Introduction to FC 300</b>	13
□ Safety Precautions	13
□ Disposal Instructions	14
□ Software Version	15
□ Control Principle	18
□ FC 300 Controls	18
□ FC 301 vs. FC 302 Control Principle	19
□ Control Structure in VVC <sup>plus</sup>	20
□ Control Structure in Flux Sensorless (FC 302 only)	21
□ Control Structure in Flux with Motor Feedback	21
□ Internal Current Control in VVC <sup>plus</sup> Mode	22
□ Local (Hand On) and Remote (Auto On) Control	22
□ Reference Handling	24
□ Scaling of References and Feedback	26
□ Dead Band Around Zero	27
□ Speed PID Control	31
□ The following parameters are relevant for the speed control	31
□ Process PID Control	34
□ Ziegler Nichols Tuning Method	38
□ Motor cables to comply with EMC regulations	40
□ EMC Immunity	41
□ Ground Leakage Current	43
□ Selection of Brake Resistor	43
□ Mechanical Brakecontrol	46
□ Hoist Mechanical Brake	47
□ Safe Stop of FC 300	50
□ Safe Stop Installation (FC 302 and FC 301 - A1 enclosure only)	51
□ Safe Stop Commissioning Test	52
■ <b>FC 300 Selection</b>	55
□ Electrical Data	55
□ General Specifications	61
□ Efficiency	66
□ Acoustic Noise	67
□ Peak Voltage on Motor	67

□ Purpose of derating	68
□ Automatic adaptations to ensure performance	71
■ <b>How to Order</b>	73
□ Drive Configurator	73
□ Ordering Form Type Code	73
□ Ordering Numbers	76
■ <b>How to Install</b>	83
□ Mechanical Dimension	83
□ Mechanical Installation	85
□ Accessory Bag	85
□ Electrical Installation	89
□ Removal of Knockouts for Extra Cables	89
□ Connection to Line Power and Grounding	90
□ Motor Connection	92
□ Fuses	94
□ Access to Control Terminals	97
□ Control Terminals	97
□ Electrical Installation, Control Terminals	98
□ Basic Wiring Example	99
□ Electrical Installation, Control Cables	100
□ Motor Cables	102
□ Switches S201, S202, and S801	102
□ Final Set-Up and Test	103
□ Additional Connections	105
□ Relay Connection	105
□ Relay Output	107
□ Parallel Connection of Motors	107
□ Motor Thermal Protection	108
□ How to Connect a PC to the FC 300	109
□ The FC 300 Software Dialog	110
□ Residual Current Device	115
■ <b>Application Examples</b>	117
□ Start/Stop	117
□ Pulse Start/Stop	117
□ Potentiometer Reference	118
□ Encoder Connection	118
□ Encoder Direction	119
□ Closed-loop Drive System	119
□ Programming of Torque Limit and Stop	119
□ Smart Logic Control Programming	121
■ <b>Options and Accessories</b>	123

□ Options and Accessories	123
□ Mounting Option Modules in Slot B	123
□ General Purpose Input Output Module MCB 101	123
□ Encoder Option MCB 102	126
□ Resolver Option MCB 103	128
□ Relay Option MCB 105	130
□ 24 V Backup Option MCB 107 (Option D)	132
□ IP 21/IP 4X/ TYPE 1 (NEMA 1) Enclosure Kit	134
□ Sine-wave Filters	135
■ <b>RS-485 Installation and Set-up</b>	137
□ RS-485 Installation and Set-up	137
□ FC Protocol Overview	140
□ Network Configuration	140
□ FC Protocol Message Framing Structure - FC 300	141
□ Examples	146
□ Danfoss FC Control Profile	147
■ <b>Troubleshooting</b>	157
□ Status messages - FC 300 DG	157
□ Warnings/Alarm Messages	157
■ <b>Index</b>	166



## How to Read this Design Guide

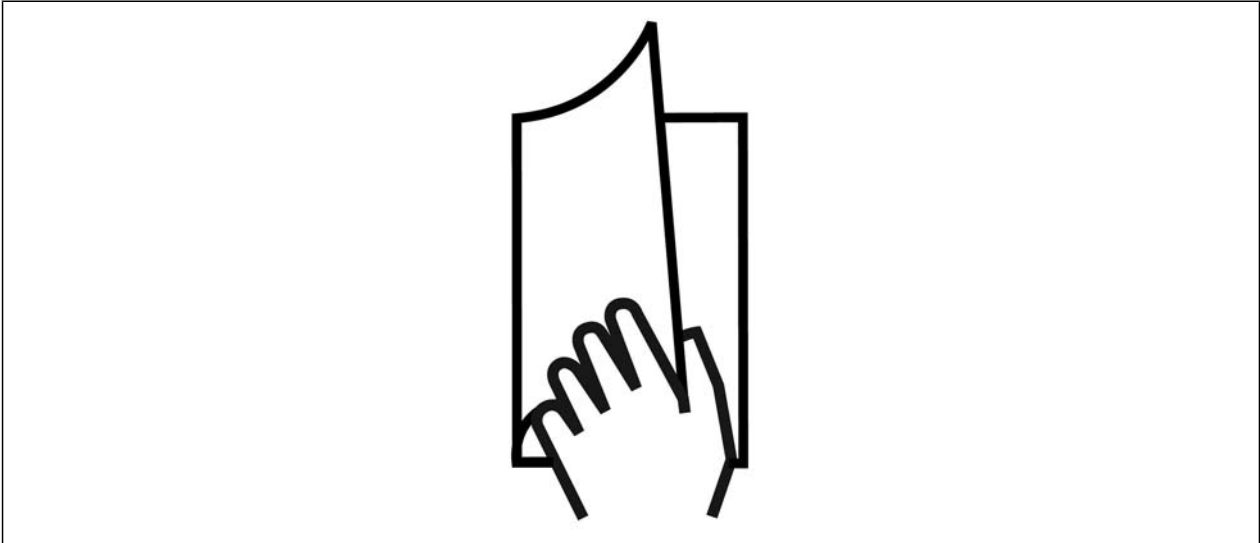

### □ How to Read this Design Guide

This Design Guide will introduce all aspects of your FC 300.

#### Available literature for FC 300

- The VLT® AutomationDrive FC 300 Instruction Manual MG.33.AX.YY provides the necessary information for getting the drive up and running.
- The VLT® AutomationDrive FC 300 Design Guide MG.33.BX.YY contains all the technical information about the drive, customer design and applications.
- The VLT® AutomationDrive FC 300 Programming Guide MG.33.MX.YY provides information on how to program and includes complete parameter descriptions.
- The VLT® AutomationDrive FC 300 Profibus Instruction Manual MG.33.CX.YY provides all the information required for controlling, monitoring and programming the drive via a Profibus serial communication bus.
- The VLT® AutomationDrive FC 300 DeviceNet Instruction Manual MG.33.DX.YY provides the information required for controlling, monitoring and programming the drive via a DeviceNet serial communication bus.

X = Revision number

YY = Language code

Danfoss Drives technical literature is also available online at [www.danfoss.com/BusinessAreas/Drives-Solutions/Documentations/Technical+Documentation](http://www.danfoss.com/BusinessAreas/Drives-Solutions/Documentations/Technical+Documentation).

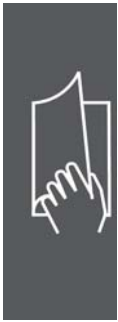

□ **Approvals**



□ **Symbols**

Symbols used in this guide.



**NOTE**

Indicates something to be noted by the reader.



Indicates a general warning.



Indicates a high-voltage warning.

\* Indicates a default setting

□ **Abbreviations**

Alternating current	AC
American wire gauge	AWG
Ampere/AMP	A
Automatic Motor Adaptation	AMA
Current limit	$I_{LIM}$
Degrees Celsius	°C
Direct current	DC
Drive Dependent	D-TYPE
Electro Magnetic Compatibility	EMC
Electronic Thermal Relay	ETR
Adjustable Frequency Drive	FC
Gram	g
Hertz	Hz
Kilohertz	kHz
Local Control Panel	LCP
Meter	m
Milli Henry Inductance	mH
Milliampere	mA
Millisecond	ms
Minute	min
Motion Control Tool	MCT
Nanofarad	nF
Newton meter	Nm
Nominal motor current	$I_{M,N}$
Nominal motor frequency	$f_{M,N}$
Nominal motor power	$P_{M,N}$
Nominal motor voltage	$U_{M,N}$
Parameter	par.
Protective Extra Low Voltage	PELV
Printed Circuit Board	PCB
Rated Inverter Output Current	$I_{INV}$
Revolutions Per Minute	RPM
Second	s
Torque limit	$T_{LIM}$
Volt	V





□ **Definitions**

**Drive:**

D-TYPE

Size and type of the connected drive (dependencies).

I<sub>VLT,MAX</sub>

The maximum output current.

I<sub>VLT,N</sub>

The rated output current supplied by the adjustable frequency drive.

U<sub>VLT, MAX</sub>

The maximum output voltage.

**Input:**

Control command

You can start and stop the connected motor using the LCP and the digital inputs.

Functions are divided into two groups.

Functions in group 1 have higher priority than functions in group 2.

Group 1	Reset, Coasting stop, Reset and Coasting stop, Quick stop, DC braking, Stop and the "Off" key.
Group 2	Start, Pulse start, Reversing, Start reversing, Jog and Freeze output

**Motor:**

f<sub>JOG</sub>

The motor frequency when the jog function is activated (via digital terminals).

f<sub>M</sub>

The motor frequency.

f<sub>MAX</sub>

The maximum motor frequency.

f<sub>MIN</sub>

The minimum motor frequency.

f<sub>M,N</sub>

The rated motor frequency (nameplate data).

I<sub>M</sub>

The motor current.

I<sub>M,N</sub>

The rated motor current (nameplate data).

M-TYPE

Size and type of the connected motor (dependencies).

n<sub>M,N</sub>

The rated motor speed (nameplate data).

P<sub>M,N</sub>

The rated motor power (nameplate data).

T<sub>M,N</sub>

The rated torque (motor).



$U_M$ 

The instantaneous motor voltage.

 $U_{M,N}$ 

The rated motor voltage (nameplate data).

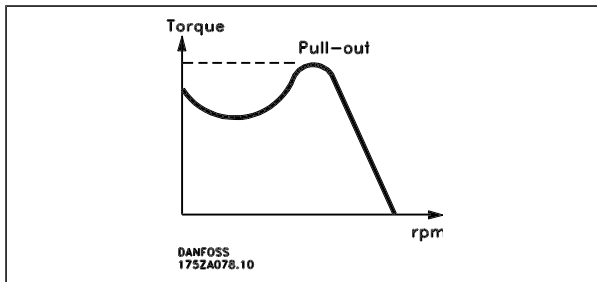
Break-away torque $\eta_{VLT}$ 

The efficiency of the adjustable frequency drive is defined as the ratio between the power output and the power input.

Start-disable command

A stop command belonging to the group 1 control commands - see this group.

Stop command

See Control commands.

**References:**Analog Reference

A signal transmitted to the analog inputs 53 or 54 can be voltage or current.

Binary Reference

A signal transmitted to the serial communication port.

Preset Reference

A defined preset reference to be set from -100% to +100% of the reference range. Selection of eight preset references via the digital terminals.

Pulse Reference

A pulse frequency signal transmitted to the digital inputs (terminal 29 or 33).

Ref<sub>MAX</sub>

Determines the relationship between the reference input at 100% full scale value (typically 10 V, 20mA) and the resulting reference. The maximum reference value set in par. 3-03.

Ref<sub>MIN</sub>

Determines the relationship between the reference input at 0% value (typically 0V, 0mA, 4mA) and the resulting reference. The minimum reference value set in par. 3-02.

**Miscellaneous:**Analog Inputs

The analog inputs are used for controlling various functions of the adjustable frequency drive. There are two types of analog inputs:





Current input, 0-20 mA and 4-20 mA  
Voltage input, 0-10 V DC (FC 301)  
Voltage input, -10 - +10 V DC (FC 302).

#### Analog Outputs

The analog outputs can supply a signal of 0-20 mA, 4-20 mA, or a digital signal.

#### Automatic Motor Adaptation, AMA

AMA algorithm determines the electrical parameters for the connected motor at standstill.

#### Brake Resistor

The brake resistor is a module capable of absorbing the braking energy generated in regenerative braking. This regenerative braking energy increases the intermediate circuit voltage, and a brake chopper ensures that the energy is transmitted to the brake resistor.

#### CT Characteristics

Constant torque characteristics used for all applications such as conveyor belts, displacement pumps and cranes.

#### Digital Inputs

The digital inputs can be used for controlling various functions of the adjustable frequency drive.

#### Digital Outputs

The drive features two solid state outputs that can supply a 24 V DC (max. 40 mA) signal.

#### DSP

Digital Signal Processor.

#### ETR

Electronic Thermal Relay is a thermal load calculation based on present load and time. Its purpose is to estimate the motor temperature.

#### Hiperface®

Hiperface® is a registered trademark by Stegmann.

#### Initializing

If initializing is carried out (par. 14-22), the adjustable frequency drive returns to the default setting.

#### Intermittent Duty Cycle

An intermittent duty rating refers to a sequence of duty cycles. Each cycle consists of an on-load and an off-load period. The operation can be either periodic duty or non-periodic duty.

#### LCP

The Local Control Panel (LCP) makes up a complete interface for control and programming of the FC 300 Series. The control panel is detachable and can be installed up to 9.8 ft (3 meters) from the adjustable frequency drive, i.e. in a front panel by means of the installation kit option.

#### lsb

Least significant bit.

#### msb

Most significant bit.

#### MCM

Short for Mille Circular Mil, an American measuring unit for cable cross-section. 1 MCM = 0.00079 in<sup>2</sup> [0.5067 mm<sup>2</sup>].

#### Online/Offline Parameters

Changes to online parameters are activated immediately after the data value is changed. Changes to offline parameters are not activated until you enter [OK] on the LCP.

#### Process PID

The PID regulator maintains the desired speed, pressure, temperature, etc. by adjusting the output frequency to match the varying load.

#### Pulse Input/Incremental Encoder

An external, digital pulse transmitter used for feeding back information on motor speed. The encoder is used in applications where great accuracy in speed control is required.

#### RCD

Residual Current Device.

#### Set-up

You can save parameter settings in four set-ups. Change between the four parameter set-ups and edit one set-up while another set-up is active.

#### SFAVM

Switching pattern called Stator Flux oriented Aynchronous Vector Modulation (par. 14-00).

#### Slip Compensation

The adjustable frequency drive compensates for the motor slip by giving the frequency a supplement that follows the measured motor load keeping the motor speed almost constant..

#### Smart Logic Control (SLC)

The SLC is a sequence of user-defined actions executed when the associated user-defined events are evaluated as true by the SLC. (Parameter group 13-xx).

#### FC Standard Bus

Includes RS-485 bus with the FC protocol or MC protocol. See parameter 8-30.

#### Thermistor:

A temperature-dependent resistor placed where the temperature is to be monitored (adjustable frequency drive or motor).

#### Trip

A state entered in fault situations, such as when the adjustable frequency drive is subject to an over-temperature, or when the adjustable frequency drive is protecting the motor, process or mechanism. Restart is prevented until the cause of the fault has disappeared and the trip state is cancelled by activating reset or, in some cases, by being programmed to reset automatically. Trip may not be used for personal safety.

#### Trip-Locked

A state entered in fault situations when the adjustable frequency drive is protecting itself and requiring physical intervention, such as when the adjustable frequency drive is subject to a short circuit on the output. A locked trip can only be cancelled by cutting off AC line, removing the cause of the fault and reconnecting the adjustable frequency drive . Restart is prevented until the trip state is cancelled by activating reset or, in some cases, by being programmed to reset automatically. Trip may not be used for personal safety.

#### VT Characteristics

Variable torque characteristics used for pumps and fans.



VVC<sup>plus</sup>

Compared with standard voltage/frequency ratio control, Voltage Vector Control (VVC<sup>plus</sup>) improves the dynamics and the stability, both when the speed reference is changed and in relation to the load torque.

60° AVM

Switching pattern called 60°Asynchronous Vector Modulation (par. 14-00).

Power Factor

The power factor is the relation between  $I_1$  and  $I_{RMS}$ .

$$Power\ factor = \frac{\sqrt{3} \times U \times I_1 \times \cos\varphi}{\sqrt{3} \times U \times I_{RMS}}$$

The power factor for 3-phase control:

$$= \frac{I_1 \times \cos\varphi_1}{I_{RMS}} = \frac{I_1}{I_{RMS}} \text{ since } \cos\varphi_1 = 1$$

The power factor indicates to which extent the adjustable frequency drive imposes a load on the line supply.

$$I_{RMS} = \sqrt{I_1^2 + I_5^2 + I_7^2 + \dots + I_n^2}$$

The lower the power factor, the higher the  $I_{RMS}$  for the same kW performance.

In addition, a high power factor indicates that the different harmonic currents are low.

The FC 300 adjustable frequency drives' built-in DC coils produce a high power factor, which minimizes the imposed load on the line supply.

## Introduction to FC 300

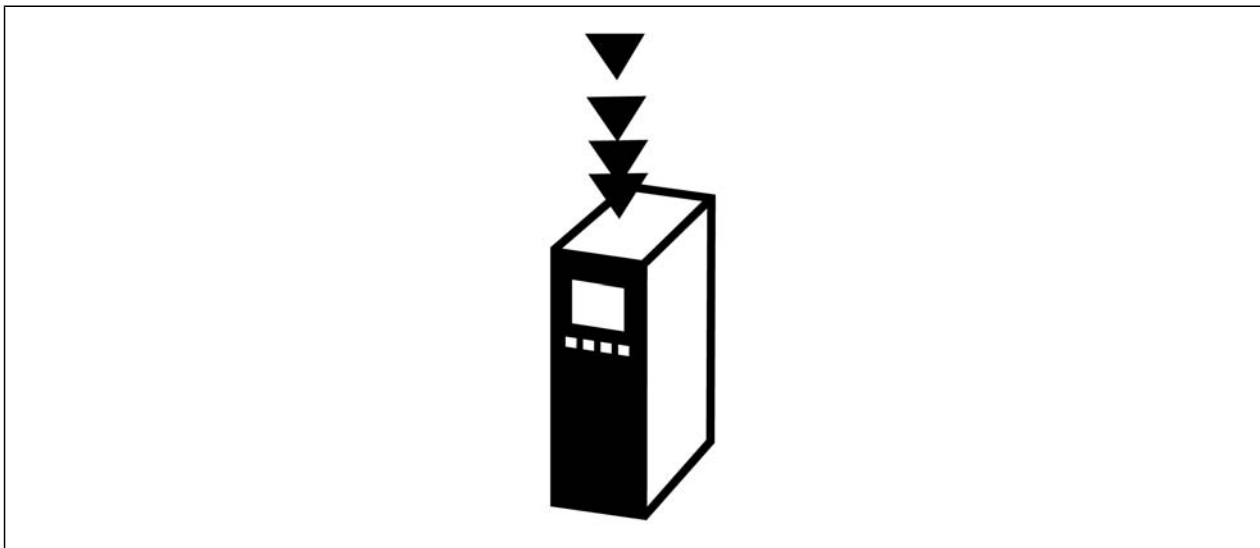

### □ Safety Precautions



The voltage of the adjustable frequency drive is dangerous whenever connected to line power. Incorrect installation of the motor, adjustable frequency drive or serial communication bus may cause damage to the equipment, serious personal injury or death. Consequently, the instructions in this manual, as well as national and local rules and safety regulations, must be complied with.

#### Safety Regulations

1. The adjustable frequency drive must be disconnected from the line power if repair work is to be carried out. Make sure that the line supply has been disconnected and that the necessary time has passed before removing motor and line plugs.
2. The [STOP/RESET] key on the control panel of the adjustable frequency drive does not disconnect the equipment from line power and is thus not to be used as a safety switch.
3. Correct protective grounding of the equipment must be established, the user must be protected against supply voltage, and the motor must be protected against overload in accordance with applicable national and local regulations.
4. The ground leakage currents are higher than 3.5 mA.
5. Protection against motor overload is not included in the factory setting. If this function is desired, set par. 1-90 to data value ETR trip or data value ETR warning.



#### NOTE

The function is initialized at 1.16 x rated motor current and rated motor frequency. For the North American market: The ETR functions provide class 20 motor overload protection in accordance with NEC.

6. Do not remove the plugs for the motor and line supply while the adjustable frequency drive is connected to line power. Make sure that the line supply has been disconnected and that the necessary time has passed before removing motor and line plugs.

— Introduction to FC 300 —

7. Please note that the adjustable frequency drive has more voltage inputs than L1, L2 and L3 when load sharing (linking of DC intermediate circuit) and external 24 V DC have been installed. Make sure that all voltage inputs have been disconnected and that the necessary time has passed before commencing repair work.

**Warning against Unintended Start**

1. The motor can be brought to a stop by means of digital commands, bus commands, references or a local stop, while the adjustable frequency drive is connected to AC line. If personal safety considerations make it necessary to ensure that no unintended start occurs, these stop functions are not sufficient.
2. While parameters are being changed, the motor may start. Consequently, the stop key [STOP/RESET] must always be activated, after which data can be modified.
3. A motor that has been stopped may start if faults occur in the electronics of the adjustable frequency drive, or if a temporary overload or a fault in the supply line or the motor connection ceases.



Touching the electrical parts may be fatal - even after the equipment has been disconnected from line power.

Also, make sure that other voltage inputs have been disconnected, such as external 24 V DC, load sharing (linkage of DC intermediate circuit), as well as the motor connection for kinetic backup. Refer to FC 300 Operating Instructions (MG.33.A8.xx) for further safety guidelines.

□ **Disposal Instructions**



Equipment containing electrical components may not be disposed of together with domestic waste. It must be collected separately as electrical and electronic waste in accordance with local and currently valid legislation.



**Caution**

The FC 300 AutomationDrive DC link capacitors remain charged after power has been disconnected. To avoid electrical shock, disconnect the FC 300 from the line supply before carrying out maintenance procedures. Before servicing the adjustable frequency drive, wait the minimum amount of time indicated below:

FC 300:	0.33-10 hp [0.25–7.5 kW]	4 minutes
FC 300:	15-30 hp [11–22 kW]	15 minutes
FC 300:	40-100 hp [30-75 kW]	15 minutes

**FC 300**  
**Design Guide**  
**Software version: 4.0x**



This Design Guide can be used for all FC 300 adjustable frequency drives with software version 4.0x. The software version number can be seen in parameter 15-43.



## □ CE Conformity and Labeling

### What is CE Conformity and Labeling?

The purpose of CE labeling is to avoid technical trade obstacles within EFTA and the EU. The EU has introduced the CE label as a simple way of showing whether a product complies with the relevant EU directives. The CE label says nothing about the specifications or quality of the product. Adjustable frequency drives are regulated by three EU directives:

#### The machinery directive (98/37/EEC)

All machines with critical moving parts are covered by the machinery directive of January 1, 1995. Since an adjustable frequency drive is largely electrical, it does not fall under the machinery directive. However, if an adjustable frequency drive is supplied for use in a machine, we provide information on safety aspects relating to the adjustable frequency drive. We do this by means of a manufacturer's declaration.

#### The low-voltage directive (73/23/EEC)

Adjustable frequency drives must be CE-labeled in accordance with the low-voltage directive of January 1, 1997. The directive applies to all electrical equipment and appliances used in the 50-1000 V AC and the 75-1500 V DC voltage ranges. Danfoss uses CE labels in accordance with the directive and will issue a declaration of conformity upon request.

#### The EMC directive (89/336/EEC)

EMC is short for electromagnetic compatibility. The presence of electromagnetic compatibility means that the mutual interference between different components/appliances does not affect the way the appliances work.

The EMC directive came into effect January 1, 1996. Danfoss uses CE labels in accordance with the directive and issues a declaration of conformity upon request. To carry out EMC-correct installation, see the instructions in this Design Guide. In addition, we specify which standards our products comply with. We offer the filters presented in the specifications and provide other types of assistance to ensure the optimum EMC result.

The adjustable frequency drive is most often used by professionals of the trade as a complex component forming part of a larger appliance, system or installation. It must be noted that the responsibility for the final EMC properties of the appliance, system or installation rests with the installer.

## □ What Is Covered

The EU "Guidelines on the Application of Council Directive 89/336/EEC" outline three typical situations of using an adjustable frequency drive. See below for EMC coverage and CE labeling.

1. The adjustable frequency drive is sold directly to the end-consumer. For example, it may be sold to a DIY market. The end-consumer is a layman. He installs the adjustable frequency drive himself for use with a hobby machine, a kitchen appliance, etc. For such applications, the adjustable frequency drive must be CE labeled in accordance with the EMC directive.
2. The adjustable frequency drive is sold for installation in a plant. The plant is built up by professionals of the trade. It could be a production plant or a heating/ventilation plant designed and installed by professionals of the trade. Neither the adjustable frequency drive nor the finished plant must be CE labeled under the EMC directive. However, the unit must comply with the basic EMC requirements of the directive. This is ensured by using components, appliances and systems that are CE labeled under the EMC directive.
3. The adjustable frequency drive is sold as part of a complete system. The system is being marketed as complete and could, for example, be an air-conditioning system. The complete system must be CE labeled in accordance with the EMC directive. The manufacturer can ensure CE labeling under the EMC directive either by using CE labeled components or by testing the EMC of





the system. If he chooses to use only CE labeled components, he does not have to test the entire system.

#### □ Danfoss VLT Adjustable Frequency Drive and CE Labeling

CE labeling is a positive feature when used for its original purpose, i.e. to facilitate trade within the EU and EFTA.

However, CE labeling may cover many different specifications. Thus, you must check what a given CE label specifically covers.

The covered specifications can be very different and a CE label may therefore give the installer a false sense of security when using an adjustable frequency drive as a component in a system or an appliance.

Danfoss CE labels the adjustable frequency drives in accordance with the low-voltage directive. This means that if the adjustable frequency drive is installed correctly, we guarantee compliance with the low-voltage directive. Danfoss issues a declaration of conformity that confirms our CE labeling in accordance with the low-voltage directive.

The CE label also applies to the EMC directive provided that the instructions for EMC-correct installation and filtering are followed. On this basis, a declaration of conformity in accordance with the EMC directive is issued.

The Design Guide offers detailed instructions for installation to ensure EMC-correct installation. Furthermore, Danfoss specifies which our different products comply with.

Danfoss gladly provides other types of assistance that can help you obtain the best EMC result.

#### □ Compliance with EMC Directive 89/336/EEC

As mentioned, the adjustable frequency drive is mostly used by professionals of the trade as a complex component forming part of a larger appliance, system or installation. It must be noted that the responsibility for the final EMC properties of the appliance, system or installation rests with the installer. To assist the installer, Danfoss has prepared EMC installation guidelines for the Power Drive system. The standards and test levels stated for Power Drive systems are complied with, provided that the correct EMC instructions for installation are followed; see section *Electrical Installation*.

The adjustable frequency drive has been designed to meet the IEC/EN 60068-2-3 standard, EN 50178 pkt. 9.4.2.2 at 122°F [50°C].

An adjustable frequency drive contains a large number of mechanical and electronic components. All are vulnerable to environmental effects to some extent.



The adjustable frequency drive should not be installed in environments with airborne liquids, particles or gases capable of affecting and damaging the electronic components. Failure to take the necessary protective measures increases the risk of stoppages, thus reducing the life of the adjustable frequency drive.

Liquids can be carried through the air and condense in the adjustable frequency drive and may cause corrosion of components and metal parts. Steam, oil and salt water may cause corrosion of components and metal parts. In such environments, use equipment with enclosure rating IP 55. As an extra protection, coated printed circuit boards can be ordered as an option.



Airborne particles such as dust may cause mechanical, electrical or thermal failure in the adjustable frequency drive. A typical indicator of excessive levels of airborne particles is the presence of dust particles around the adjustable frequency drive fan. In very dusty environments, use equipment with enclosure rating IP 55 or a cabinet for IP 00/IP 20/TYPE 1 equipment.

In environments with high temperatures and humidity, corrosive gases such as sulfur, nitrogen and chlorine compounds will cause chemical processes on the adjustable frequency drive components.

Such chemical reactions will rapidly affect and damage the electronic components. In such environments, mount the equipment in a cabinet with fresh air ventilation, keeping aggressive gases away from the adjustable frequency drive.

An extra protection in such areas is a coating of the printed circuit boards, which can be ordered as an option.



**NOTE**

Mounting adjustable frequency drives in aggressive environments increases the risk of stop-pages and considerably reduces the life of the drive.

Before installing the adjustable frequency drive, check the ambient air for liquids, particles and gases. This is done by observing existing installations in this environment. A typical indicator of harmful airborne liquids is the presence of water or oil on metal parts, or the corrosion of metal parts.

Excessive dust particle levels are often found on installation cabinets and existing electrical installations. One indicator of aggressive airborne gases is the blackening of copper rails and cable ends on existing installations.

The adjustable frequency drive has been tested according to a procedure based on the shown standards: The adjustable frequency drive complies with requirements that exist for units mounted on the walls and floors of production premises, as well as in panels bolted to walls or floors.

IEC/EN 60068-2-6:	Vibration (sinusoidal) - 1970
IEC/EN 60068-2-64:	Vibration, broad-band random

**□ Control Principle**

An adjustable frequency drive rectifies AC voltage from line into DC voltage, after which this DC voltage is converted into an AC current with a variable amplitude and frequency.

The motor is supplied with variable voltage / current and frequency, which enables infinitely variable speed control of three-phased, standard AC motors and permanent magnet synchronous motors.

**□ FC 300 Controls**

The adjustable frequency drive is capable of controlling either the speed or the torque on the motor shaft. Setting par. 1-00 determines the type of control.

Speed control:

There are two types of speed control:

- Speed open loop control which does not require any feedback (sensorless).
- Speed closed-loop control in the form of PID control that requires speed feedback to an input. Properly optimized speed closed-loop control will have higher accuracy than speed open loop control.

Selects which input to use as speed PID feedback in par. 7-00.

Torque control (FC 302 only):

Torque control is part of the motor control and correct settings of motor parameters are very important. The accuracy and settling time of the torque control are determined from *Flux w motor feedb* (par. 1-01 *Motor Control Principle*).

- Flux sensorless offers superior performance in all four quadrants at motor frequencies above 10 Hz.
- Flux with encoder feedback offers superior performance in all four quadrants and at all motor speeds.

Speed / torque reference:

The reference to these controls can either be a single reference or the sum of various references including relatively scaled references. The handling of references is explained in detail later in this section.

▣ **FC 301 vs. FC 302 Control Principle**

The FC 301 is a general-purpose adjustable frequency drive for variable speed applications. The control principle is based on voltage vector control (VVC<sup>plus</sup>).

The FC 301 can handle asynchronous motors only.

The current sensing principle in the FC 301 is based on current measurement in the DC link or motor phase. The ground fault protection on the motor side is solved by a desaturation circuit in the IGBTs connected to the control board.

Short circuit behavior in the FC 301 depends on the current transducer with positive DC link, and the desaturation protection with feedback from the 3 lower IGBTs and the brake.

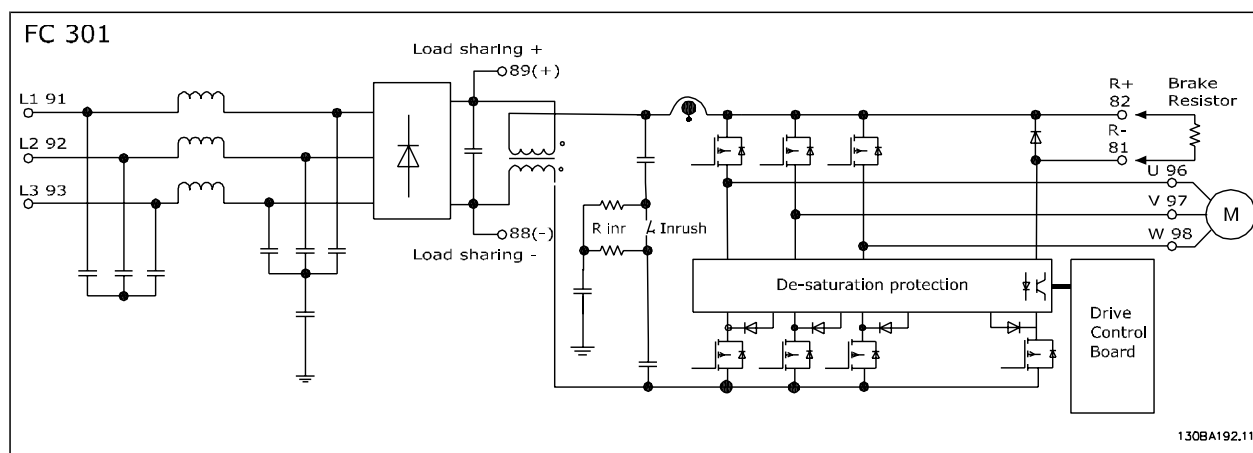

The FC 302 is a high-performance adjustable frequency drive for demanding applications. The adjustable frequency drive can handle various kinds of motor control principles such as U/f special motor mode, VVC<sup>plus</sup> or flux vector motor control.

The FC 302 is able to handle permanent magnet synchronous motors (brushless servo motors), as well as normal squirrel-cage asynchronous motors.

Short circuit behavior on the FC 302 depends on the 3 current transducers in the motor phases, and the desaturation protection with feedback from the brake.

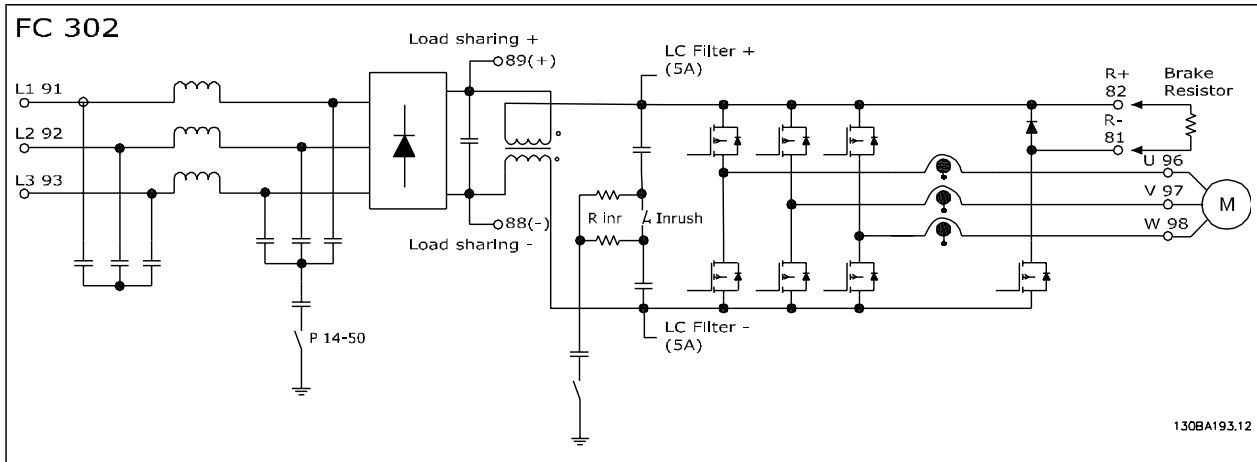

Control Structure in VVC<sup>plus</sup>

Control structure in VVC<sup>plus</sup> open-loop and closed-loop configurations:

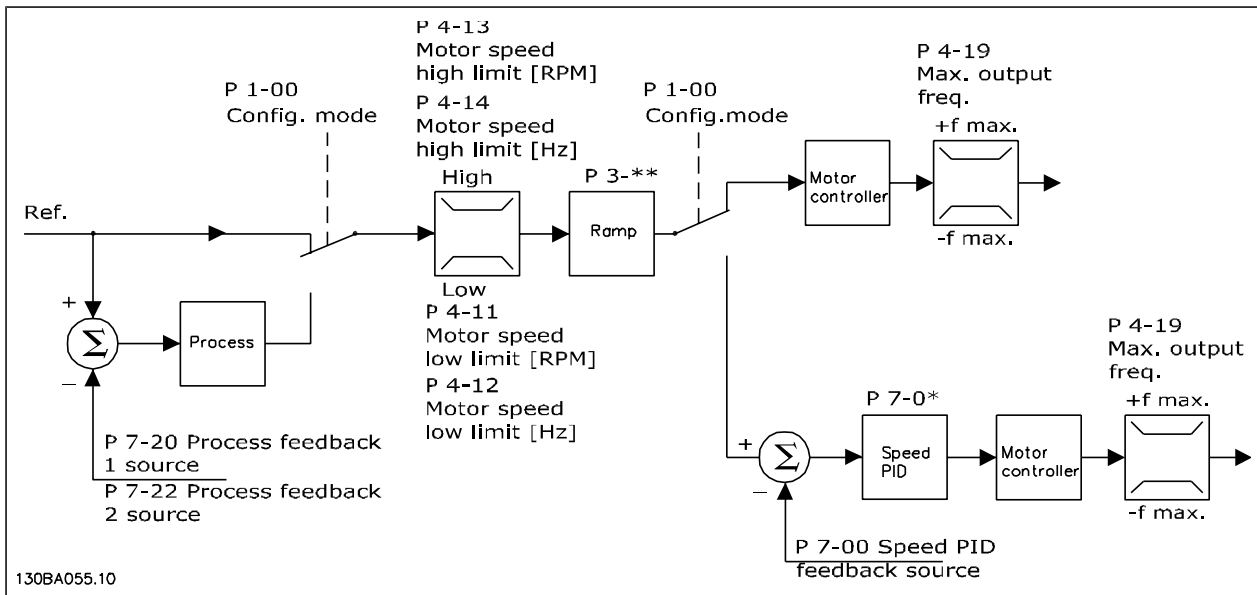

In the configuration shown in the illustration above, par. 1-01 *Motor Control Principle* is set to “VVC<sup>plus</sup> [1]” and par. 1-00 is set to “Speed open-loop [0]”. The resulting reference from the reference handling system is received and fed through the ramp limitation and speed limitation before being sent to the motor control. The output of the motor control is then limited by the maximum frequency limit.

If par. 1-00 is set to “Speed closed-loop [1],” the resulting reference will be passed from the ramp limitation and speed limitation into a speed PID control. The speed PID control parameters are located in the par. group 7-0\*. The resulting reference from the speed PID control is sent to the motor control limited by the frequency limit.

Select “Process [3]” in par. 1-00 to use the process PID control for closed-loop control of speed or pressure in the controlled application (e.g.). The process PID parameters are located in par. group 7-2\* and 7-3\*.

□ **Control Structure in Flux Sensorless (FC 302 only)**

Control structure in flux sensorless open-loop and closed-loop configurations.

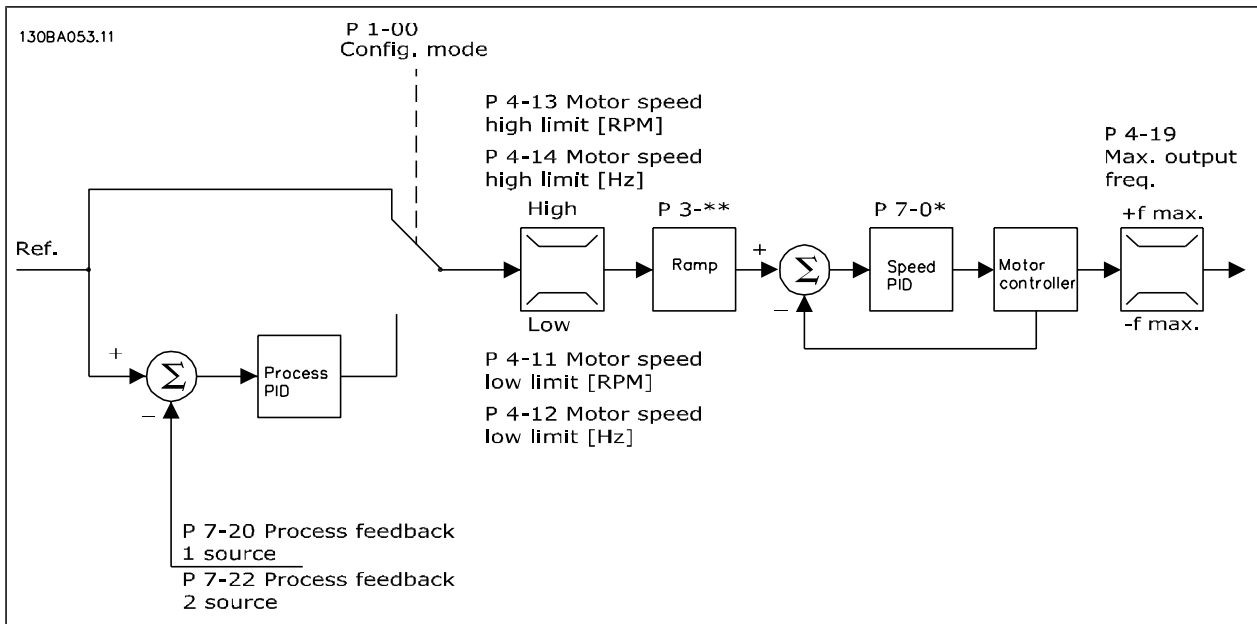

In the shown configuration, par. 1-01 *Motor Control Principle* is set to “Flux sensorless [2]” and par. 1-00 is set to “Speed open-loop [0].” The resulting reference from the reference handling system is fed through the ramp and speed limitations as determined by the parameter settings indicated.

An estimated speed feedback is generated to the speed PID to control the output frequency. The speed PID must be set with its P, I, and D parameters (par. group 7-0\*).

Select “Process [3]” in par. 1-00 to use the process PID control for closed-loop control of speed or pressure in the controlled application. The process PID parameters are found in par. group 7-2\* and 7-3\*.

□ **Control Structure in Flux with Motor Feedback**

Control structure in Flux with motor feedback configuration (only available in FC 302):

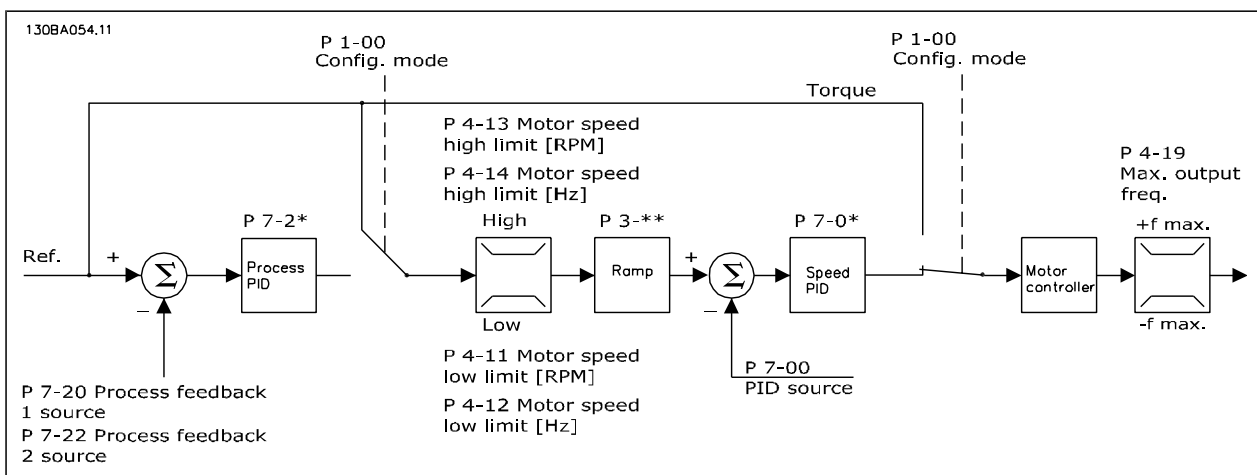

In the shown configuration, par. 1-01 *Motor Control Principle* is set to “Flux w motor feedb [3]” and par. 1-00 is set to “Speed closed-loop [1]”.

The motor control in this configuration relies on a feedback signal from an encoder mounted directly on the motor (set in par. 1-02 *Motor Shaft Encoder Source*).

Select "Speed closed-loop [1]" in par. 1-00 to use the resulting reference as an input for the speed PID control. The speed PID control parameters are located in par. group 7-0\*.

Select "Torque [2]" in par. 1-00 to use the resulting reference directly as a torque reference. Torque control can only be selected in the *Flux with motor feedback* (par. 1-01 *Motor Control Principle*) configuration. When this mode has been selected, the reference will use the Nm unit. It requires no torque feedback, since the actual torque is calculated on the basis of the current measurement of the adjustable frequency drive.

Select "Process [3]" in par. 1-00 to use the process PID control for closed-loop control of speed or a process variable in the controlled application (e.g.).

#### □ Internal Current Control in VVC<sup>plus</sup> Mode

The adjustable frequency drive features an integral current limit control which is activated when the motor current, and thus the torque, is higher than the torque limits set in par. 4-16, 4-17 and 4-18.

When the adjustable frequency drive is at the current limit during motor operation or regenerative operation, the adjustable frequency drive will try to get below the preset torque limits as quickly as possible without losing control of the motor.

#### □ Local (Hand On) and Remote (Auto On) Control

The adjustable frequency drive can be operated manually via the local control panel (LCP) or remotely via analog and digital inputs and serial bus.

If allowed in par. 0-40, 0-41, 0-42, and 0-43, it is possible to start and stop the adjustable frequency drive via the LCP using the [Hand ON] and [Off] keys. Alarms can be reset via the [RESET] key. After pressing the [Hand On] key, the adjustable frequency drive goes into Hand mode and follows (as default) the local reference that can be set using the arrow key on the LCP.

After pressing the [Auto On] key, the adjustable frequency drive goes into Auto mode and follows (as default) the remote reference. In this mode, it is possible to control the adjustable frequency drive via the digital inputs and various serial interfaces (RS-485, USB, or an optional serial communication bus). See more about starting, stopping, changing ramps and parameter set-ups, etc. in par. group 5-1\* (digital inputs) or par. group 8-5\* (serial communication).

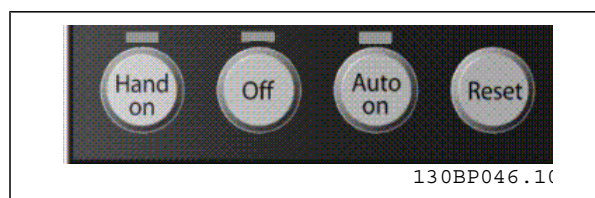

#### Active Reference and Configuration Mode

The active reference can be either the local reference or the remote reference.

In par. 3-13 *Reference Site* the local reference can be permanently selected by selecting *Local* [2]. To permanently select the remote reference select *Remote* [1]. By selecting *Linked to Hand/Auto* [0] (default) the reference site will depend on which mode is active. To permanently select the remote reference, select *Remote* [1].

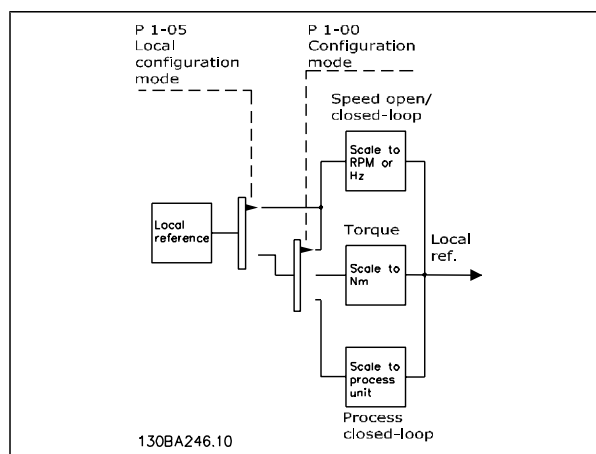
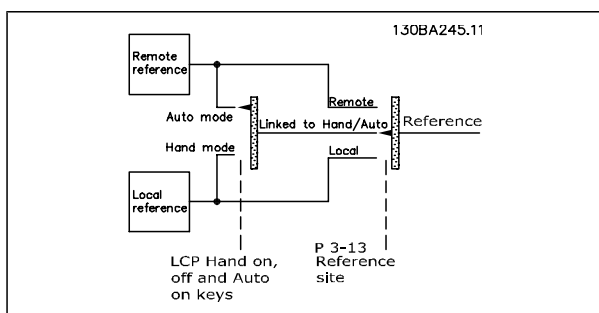

Hand On Auto LCP Keys	Reference Site Par. 3-13	Active Reference
Hand	Linked to Hand/Auto	Local
Hand -> Off	Linked to Hand/Auto	Local
Auto	Linked to Hand/Auto	Remote
Auto -> Off	Linked to Hand/Auto	Remote
All keys	Local	Local
All keys	Remote	Remote

The table shows under which conditions either the local reference or the remote reference is active. One of them is always active, but both cannot be active at the same time.

Par. 1-00 *Configuration Mode* determines what kind of application control principle (i.e., speed, torque or process control) is used when the remote reference is active (see table above for the conditions).

Par. 1-05 *Local Mode Configuration* determines the kind of application control principle that is used when the local reference is made active.

### Reference Handling

#### Local Reference

#### Remote Reference

The reference handling system for calculating the remote reference is shown in the illustration below.

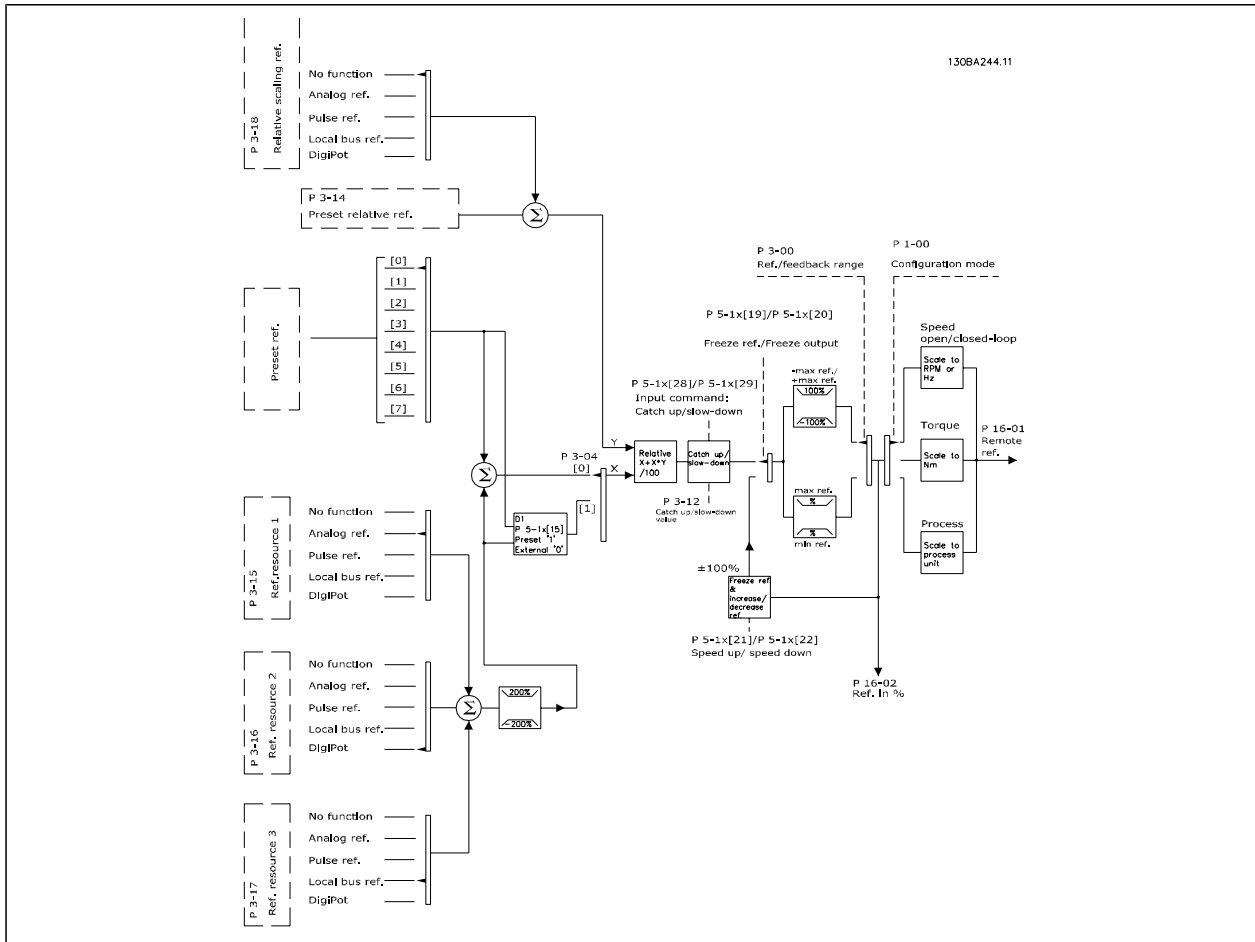

The remote reference is calculated once every scan interval and initially consists of two parts:

1. X (the external reference) : A sum (see par. 3-04) of up to four externally selected references, comprising any combination (determined by the setting of par. 3-15, 3-16 and 3-17) of a fixed preset reference (par. 3-10), variable analog references, variable digital pulse references, and various serial bus references in whatever unit the adjustable frequency drive is controlled ([Hz], [RPM], [Nm], etc.).
2. Y- (the relative reference): A sum of one fixed preset reference (par. 3-14) and one variable analog reference (par. 3-18) in [%].

The two parts are combined in the following calculation: Remote reference =  $X + X * Y / 100\%$ . The *catch up/slow-down* function and the *freeze reference* function can both be activated by digital inputs on the adjustable frequency drive. They are described in par. group 5-1\*.

The scaling of analog references is described in par. groups 6-1\* and 6-2\*, and the scaling of digital pulse references is described in par. group 5-5\*.

Reference limits and ranges are set in par. group 3-0\*.

**Reference Handling**

References and feedback can be scaled in physical units (i.e., RPM, Hz, °C) or simply in % relating to the values of par. 3-02 *Minimum Reference* and par. 3-03 *Maximum Reference*.

In this case, all analog and pulse inputs are scaled according to the following rules:



— Introduction to FC 300 —

- When par. 3-00 *Reference Range*: [0] Min - Max 0% reference equals 0 [unit] where unit can be any unit, such as rpm, m/s, bar, etc. 100% reference equals the Max (abs (par. 3-03 *Maximum Reference*), abs (par. 3-02 *Minimum Reference*)).
- When par. 3-00 *Reference Range*: [1] -Max - +Max 0% reference equals 0 [unit] -100% reference equals -Max Reference 100% reference equals Max Reference.

Bus references are scaled according to the following rules:

- When par. 3-00 *Reference Range*: [0] Min - Max. To obtain max resolution on the bus reference, the scaling on the bus is: 0% reference equals Min Reference and 100% reference equals Max reference.
- When par. 3-00 *Reference Range*: [1] -Max - +Max -100% reference equals -Max Reference 100% reference equals Max Reference.

Par. 3-00 *Reference Range*, 3-02 *Minimum Reference* and 3-03 *Maximum Reference* together define the allowed range of the sum of all references. The sum of all references is clamped when necessary. The relation between the resulting reference (after clamping) and the sum of all references is shown below.

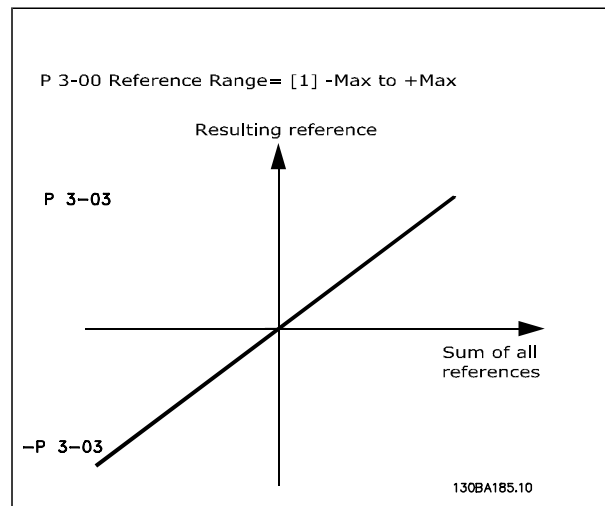
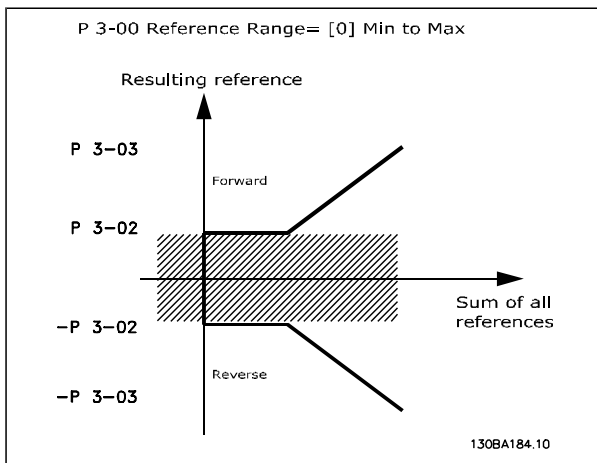

The value of par. 3-02 *Minimum Reference* cannot be set to less than 0, unless the par. 1-00 *Configuration Mode* is set to [3] Process. In this case, the subsequent relations between the resulting reference (after clamping) and the sum of all references are as shown to the right.

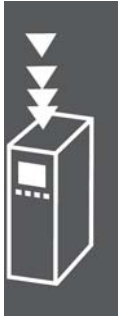
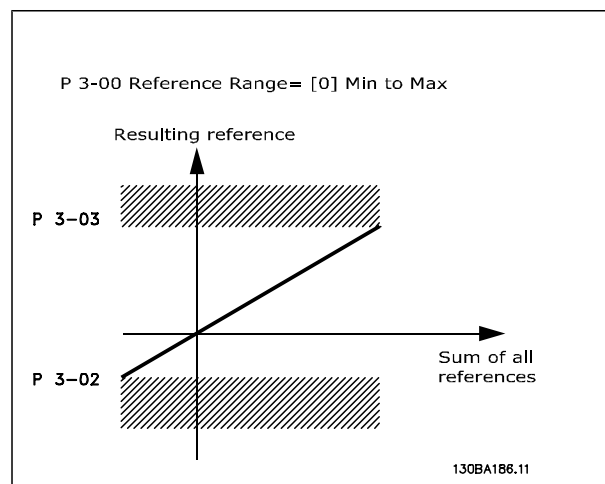

▣ **Scaling of References and Feedback**

References and feedback are scaled from analog and pulse inputs in the same way. The only difference is that a reference above or below the specified minimum and maximum “endpoints” (P1 and P2 in the graph below) are clamped, whereas a feedback above or below is not.

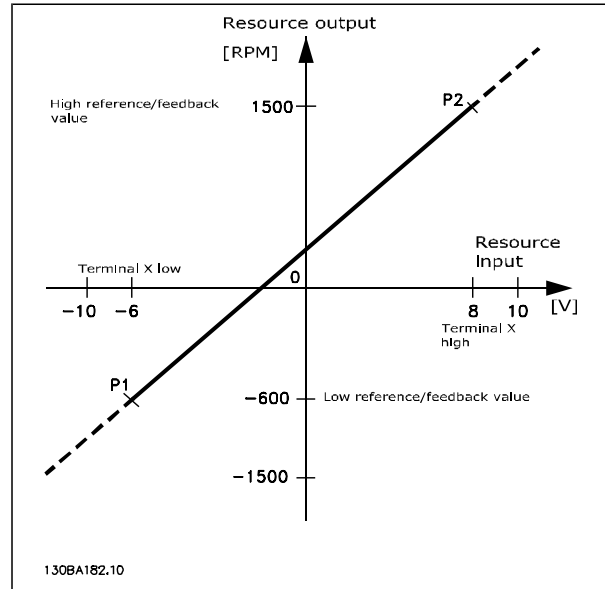
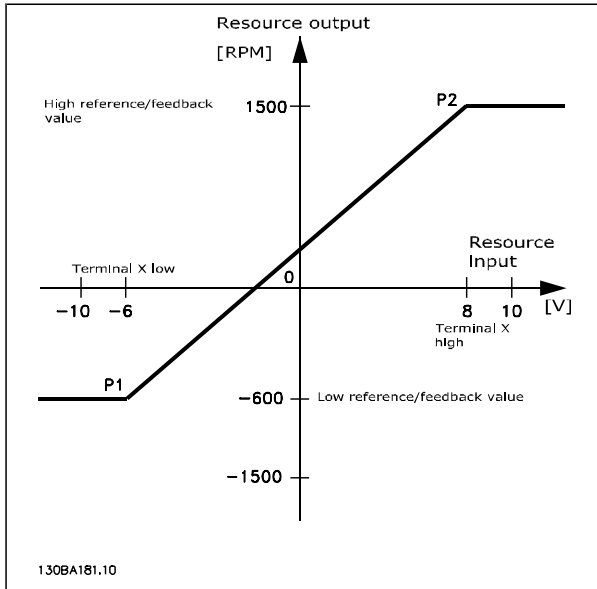

The endpoints P1 and P2 are defined by the following parameters, depending on which analog or pulse input is used

	Analog 53 S201=OFF	Analog 53 S201=ON	Analog 54 S202=OFF	Analog 54 S202=ON	Pulse Input 29	Pulse Input 33
P1 = (Minimum input value, Minimum reference value)						
Minimum reference value	Par. 6-14	Par. 6-14	Par. 6-24	Par. 6-24	Par. 5-52	Par. 5-57
Minimum input value	Par. 6-10 [V]	Par. 6-12 [mA]	Par. 6-20 [V]	Par. 6-22 [mA]	Par. 5-50 [Hz]	Par. 5-55 [Hz]
P2 = (Maximum input value, Maximum reference value)						
Maximum reference value	Par. 6-15	Par. 6-15	Par. 6-25	Par. 6-25	Par. 5-53	Par. 5-58
Maximum input value	Par. 6-11 [V]	Par. 6-13 [mA]	Par. 6-21 [V]	Par. 6-23 [mA]	Par. 5-51 [Hz]	Par. 5-56 [Hz]

**Dead Band Around Zero**

In some cases, the reference (in rare cases also the feedback) should have a Dead Band around zero (in order to ensure that the machine is stopped when the reference is “near zero”). To make the dead band active and to set the amount of dead band, the following settings must be made:

- Either Minimum Reference Value (see table above for relevant parameter) or Maximum Reference Value must be zero. In other words, either P1 or P2 must be on the X-axis in the graph below.
- And both points defining the scaling graph are in the same quadrant.

The size of the Dead Band is defined by either P1 or P2 as shown in the graph below.

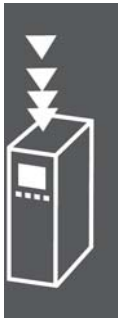
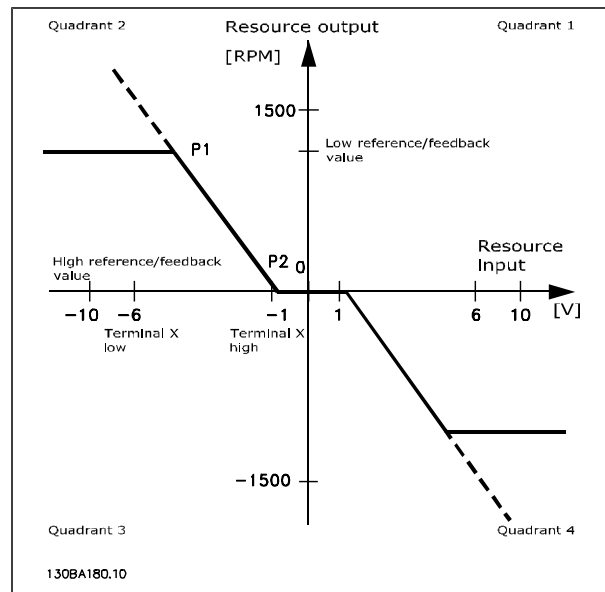
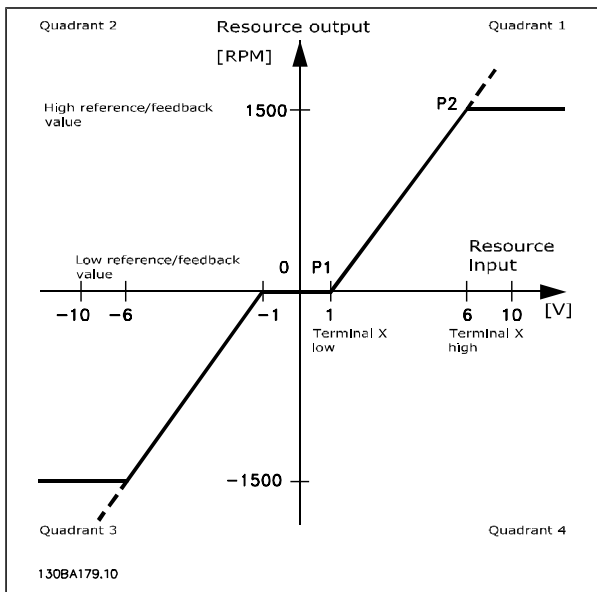

Thus, a reference endpoint of P1 = (0 V, 0 RPM) will not result in any dead band, but a reference endpoint of P1 = (1V, 0 RPM), for example, will result in a -1V to +1V dead band in this case, provided that the end point P2 is placed in either Quadrant 1 or Quadrant 4.

— Introduction to FC 300 —

**Case 1: Positive reference with dead band, digital input to trigger reverse**

This case shows how a reference input with limits inside Min – Max limits clamps.

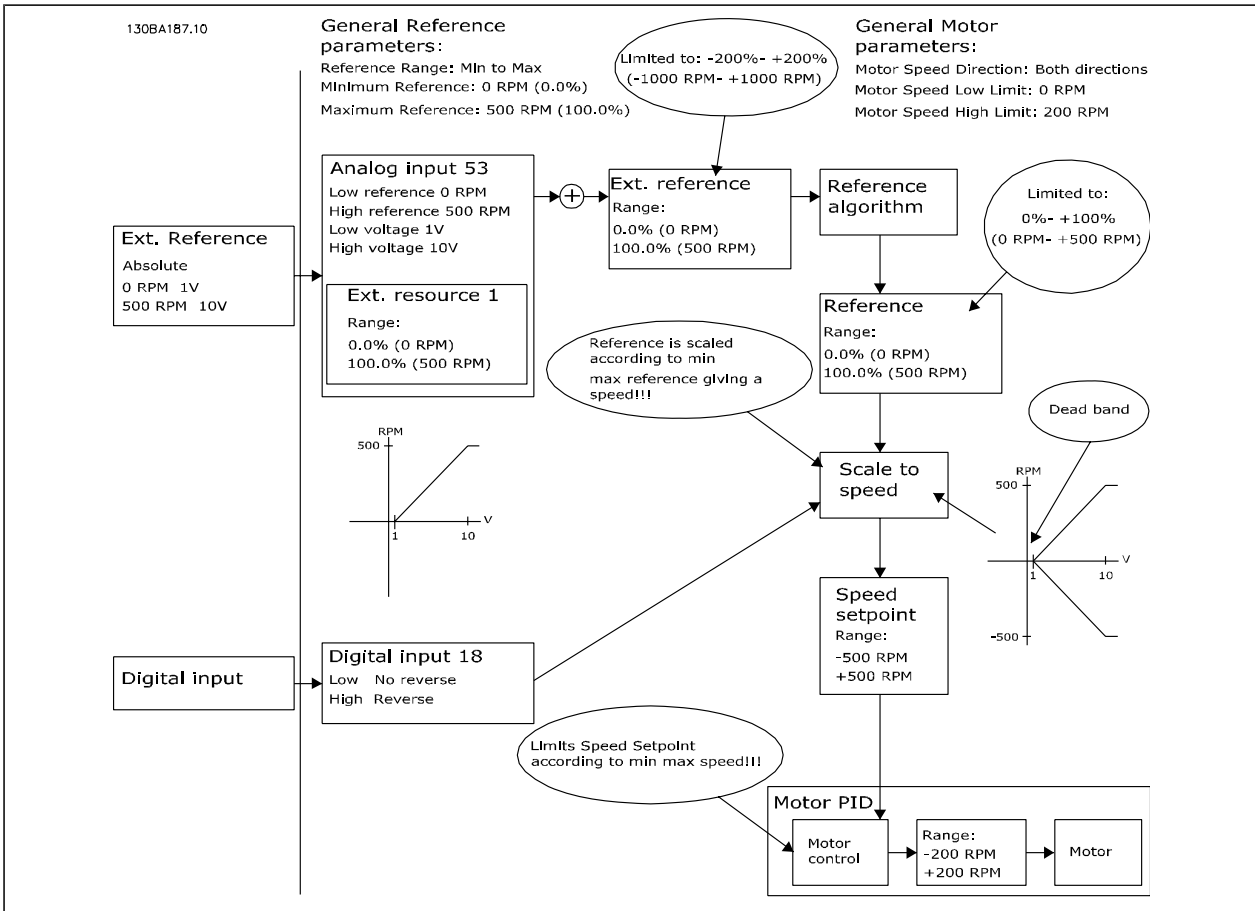

— Introduction to FC 300 —

**Case 2: Positive reference with dead band, digital input to trigger reverse. Clamping rules.**

This case shows how a reference input with limits outside -Max - +Max limits clamps to the input's low and high limits before addition to external reference, and how the external reference is clamped to -Max - +Max by the reference algorithm.

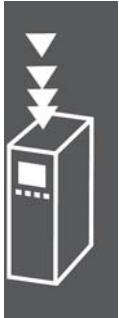
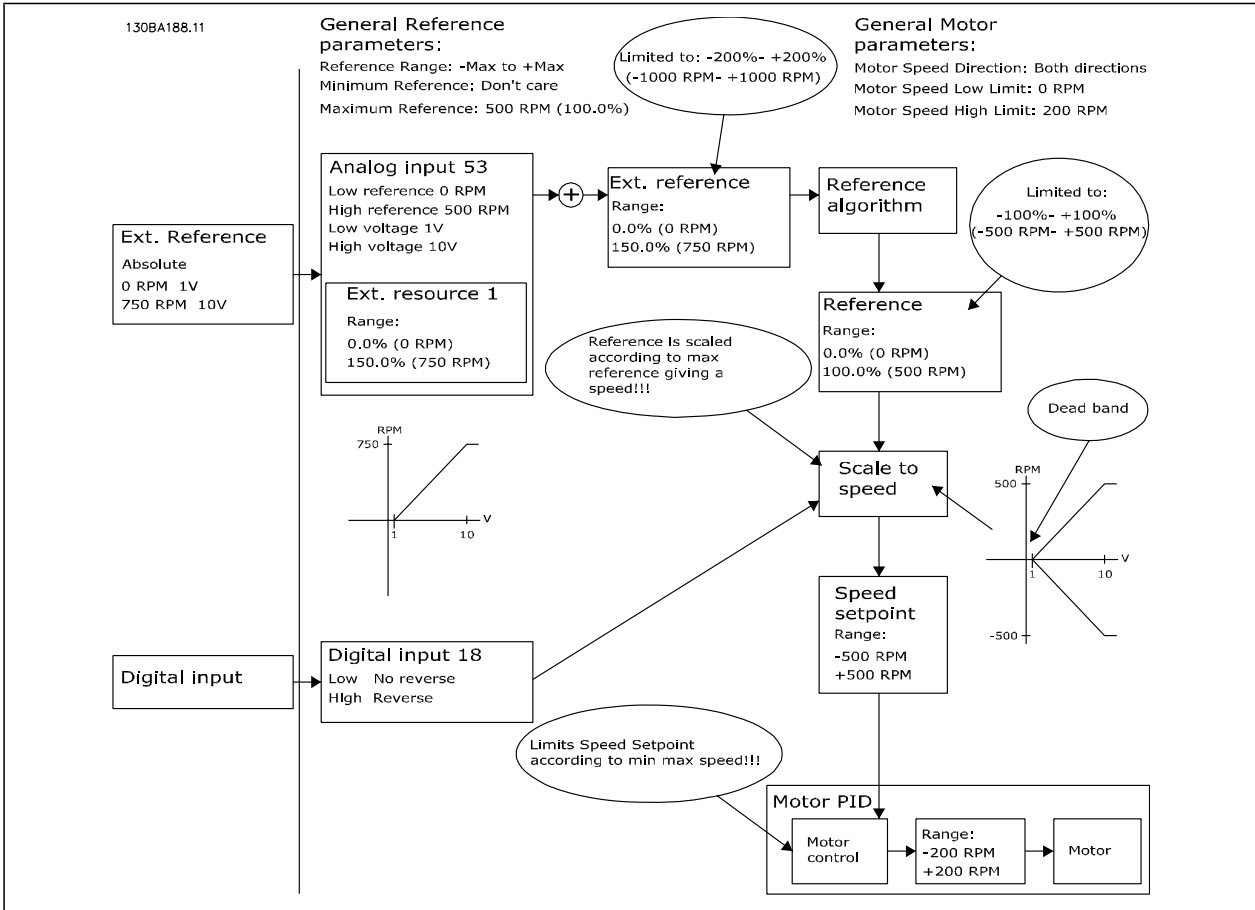

— Introduction to FC 300 —

**Case 3: Negative to positive reference with dead band, sign determines the direction, -Max - +Max**

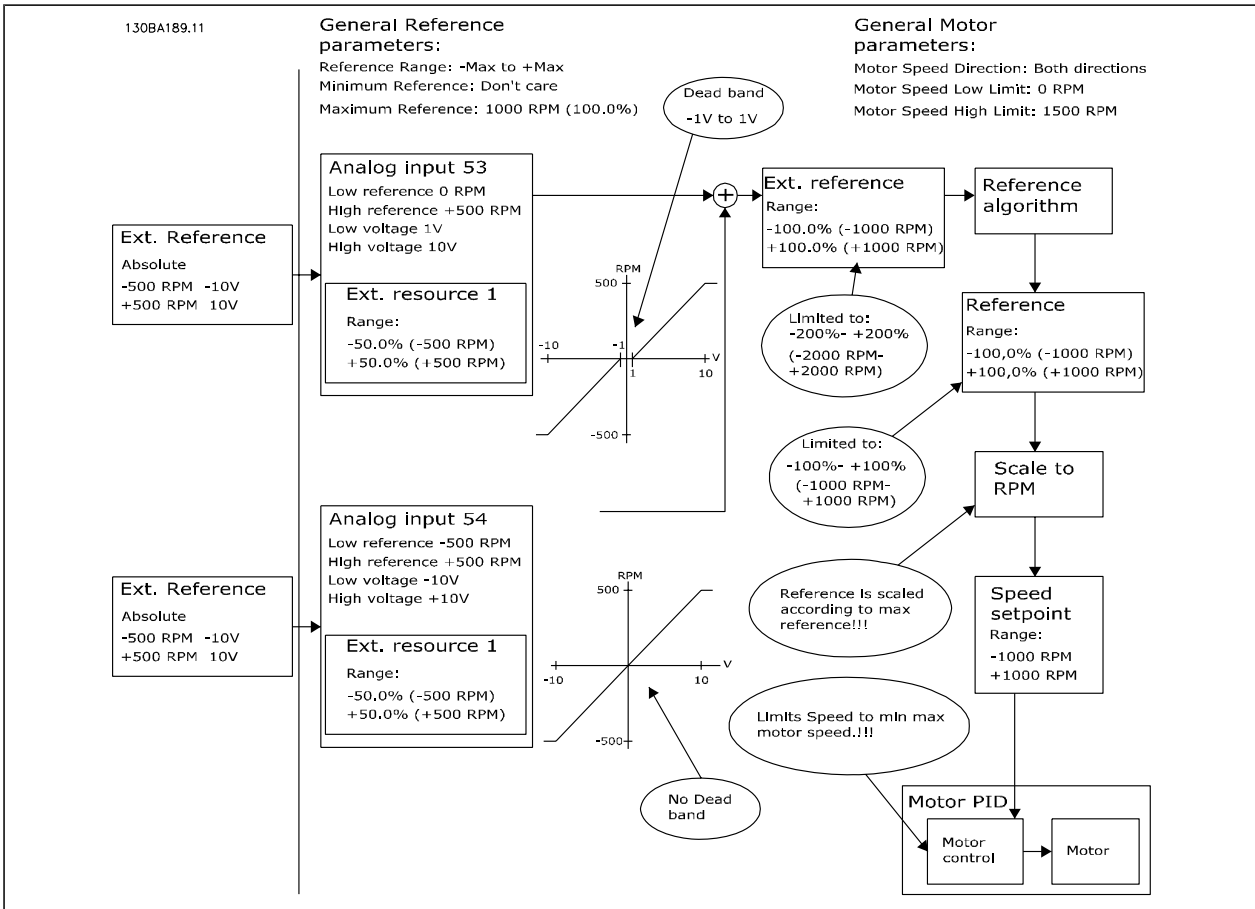

**□ Speed PID Control**

The table shows the control configurations where speed control is active.

Par. 1-00 Configuration Mode	Par. 1-01 Motor Control Principle			
	U/f	VVC <sup>plus</sup>	Flux sensorless	Flux w motor feedb
[0] Speed open loop	Not Active	Not Active	ACTIVE	N.A.
[1] Speed closed-loop	N.A.	ACTIVE	N.A.	ACTIVE
[2] Torque	N.A.	N.A.	N.A.	Not Active
[3] Process open-loop		Not Active	ACTIVE	ACTIVE

Note: "N.A." means that the specific mode is not available at all. "Not Active" means that the specific mode is available but the Speed Control is not active in that mode.

Note: The Speed Control PID will work under the default parameter setting, but tuning the parameters is highly recommended in order to optimize motor control performance. The two flux motor control principles are specially dependant on proper tuning to yield their full potential.

The following parameters are relevant for the speed control:

Parameter	Description of function	
Feedback Par. 7-00	Select from which input the speed PID should get its feedback.	
Proportional Gain Par. 7-02	The higher the value, the quicker the control. However, too high value may lead to oscillations.	
Integral Time Par. 7-03	Eliminates steady state speed error. Lower value means quick reaction. However, too high value may lead to oscillations.	
Differentiation Time Par. 7-04	Provides a gain proportional to the rate of change of the feedback. A setting of zero disables the differentiator.	
Differentiator Gain Limit Par. 7-05	If there are quick changes in reference or feedback in a given application - which means that the error changes swiftly - the differentiator may soon become too dominant. This is because it reacts to changes in the error. The quicker the error changes, the stronger the differentiator gain is. The differentiator gain can thus be limited to allow setting of the reasonable differentiation time for slow changes and a suitably quick gain for quick changes.	
Low-pass Filter Time Par. 7-06	A low-pass filter that dampens oscillations on the feedback signal and improves steady state performance. However, a filter time that is too long will deteriorate the dynamic performance of the speed PID control. Practical settings for Par 7-06 taken from the number of pulses per revolution from the encoder (PPR):	
	<b>Encoder PPR</b>	<b>Par. 7-06</b>
	512	10 ms
	1024	5 ms
	2048	2 ms
	4096	1 ms



Below is given an example of how to program the speed control:

In this case, speed PID control is used to maintain a constant motor speed regardless of the changing load on the motor.

The required motor speed is set via a potentiometer connected to terminal 53. The speed range is 0 - 1,500, which corresponds to 0 - 10V over the potentiometer.

Starting and stopping is controlled by a switch connected to terminal 18.

The speed PID monitors the actual RPM of the motor by using a 24 V (HTL) incremental encoder as feedback. The feedback sensor is an encoder (1024 pulses per revolution) connected to terminals 32 and 33.

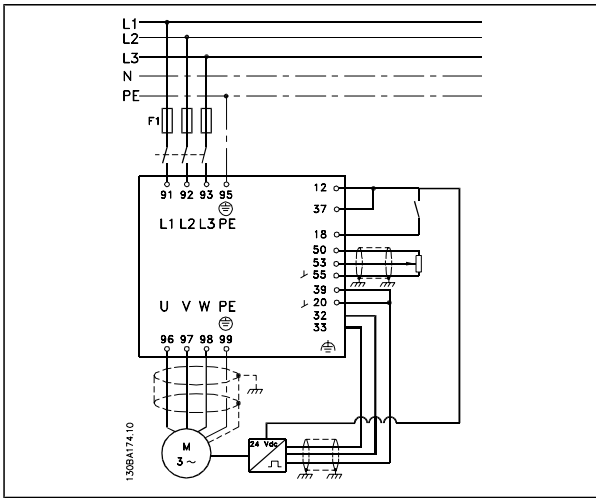

In the parameter list below, it is assumed that all other parameters and switches remain at their default setting.

The following must be programmed in order shown - see explanation of settings in the section "How to Program".



Function	Par. no.	Setting
1) Make sure the motor runs properly. Do the following:		
Set the motor parameters using nameplate data	1-2*	As specified by motor nameplate
Have the VLT make an Automatic Motor Adaptation	1-29	[1] Enable complete AMA
2) Check that the motor is running and the encoder is attached properly. Do the following:		
Press the "Hand On" LCP key. Make sure the motor is running and note in which direction it is turning (henceforth referred to as the "positive direction").		Set a <b>positive</b> reference.
Go to par. 16-20. Turn the motor slowly in the positive direction. It must be turned so slowly (only a few RPM) that it can be determined if the value in par. 16-20 is increasing or decreasing.	16-20	N.A. (read-only parameter) Note: An increasing value overflows at 65,535 and starts again at 0.
If par. 16-20 is decreasing, then change the encoder direction in par. 5-71.	5-71	[1] Counter clockwise (if par. 16-20 is decreasing)
3) Make sure the drive limits are set to safe values		
Set acceptable limits for the references.	3-02 3-03	0 RPM (default) 1,500 RPM (default)
Make sure that the ramp settings are within drive capabilities and allowed application operating specifications.	3-41 3-42	default setting default setting
Set acceptable limits for the motor speed and frequency.	4-11 4-13 4-19	0 RPM (default) 1,500 RPM (default) 60 Hz (default 132 Hz)
4) Configure the Speed Control and select the Motor Control principle		
Activation of Speed Control	1-00	[1] Speed closed-loop
Selection of Motor Control Principle	1-01	[3] Flux w motor feedb
5) Configure and scale the reference to the Speed Control		
Set up Analog Input 53 as a reference source	3-15	Not necessary (default)
Scale Analog Input 53 0 RPM (0 V) to 1,500 RPM (10V)	6-1*	Not necessary (default)
6) Configure the 24V HTL encoder signal as feedback for the Motor Control and the Speed Control		
Set up digital input 32 and 33 as encoder inputs	5-14 5-15	[0] No operation (default)
Choose terminal 32/33 as motor feedback	1-02	Not necessary (default)
Choose terminal 32/33 as Speed PID feedback	7-00	Not necessary (default)
7) Tune the speed control PID parameters		
Use the tuning guidelines when relevant or tune manually.	7-0*	See the guidelines below
8) Finished!		
Save the parameter settings to the LCP for safe-keeping.	0-50	[1] All to LCP

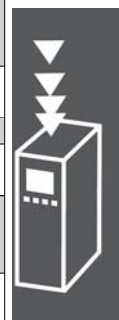

#### □ Tuning PID speed control

The following tuning guidelines are relevant when using one of the flux motor control principles in applications where the load is mainly inertial (with a low amount of friction).

The value of par. 7-02 proportional gain is dependent on the combined inertia of the motor and load, and the selected bandwidth can be calculated using the following formula:

$$Par. 7 - 02 = \frac{Total\ inertia\ [kgm^2] \times Par. 1 - 25}{Par. 1 - 20 \times 9550} \times Bandwidth\ [rad / s]$$

Note: Par. 1-20 is the motor power in [kW] (i.e., enter '4' kW instead of '4,000' W in the formula). A practical value for the bandwidth is 20 rad/s. Check the result of the par. 7-02 calculation against the following formula (not required if you are using a high resolution feedback such as a SinCos feedback):

$$Par. 7 - 02_{MAXIMUM} = \frac{0.01 \times 4 \times Encoder\ Resolution \times par. 7 - 06}{2 \times \pi} \times Max\ torque\ ripple\ [%]$$

A good start value for par. 7-06 *Speed Filter Time* is 5 ms (lower encoder resolution calls for a higher filter value). Typically, a max torque ripple of 3% is acceptable. For incremental encoders, the Encoder

Resolution is found in either par. 5-70 (24V HTL on standard drive) or par. 17-11 (5V TTL on MCB102 Option).

Generally, the practical maximum limit of par. 7-02 is determined by the encoder resolution and the feedback filter time, but other factors in the application might limit the par. 7-02 *Proportional Gain* to a lower value.

To minimize the overshoot, par. 7-03 *Integral Time* could be set to approx. 2.5 s (varies with the application).

Par. 7-04 *Differential Time* should be set to 0 until everything else is tuned. If necessary, finish the tuning by experimenting with small increments of this setting.

#### □ Process PID Control

Process PID control can be used to control application parameters that can be measured by a sensor (i.e., pressure, temperature, flow) and be affected by the connected motor through a pump, fan or otherwise.

The table shows the control configurations where the process control is possible. When a flux motor control principle is used, take care also to tune the speed control PID parameters. Refer to the section about the control structure to see where the speed control is active.

Par. 1-00 Configuration Mode	Par. 1-01 Motor Control Principle	U/f	VVC <sup>plus</sup>	Flux sensorless	Flux w motor feedb
[3] Process open-loop	N.A.	N.A.	Process	Process & Speed	Process & Speed

Note: Process control PID will work under the default parameter setting, but tuning the parameters is highly recommended to optimize the application control performance. The two flux motor control principles are specially dependant on proper speed control PID tuning (prior to tuning the process control PID) to yield their full potential.

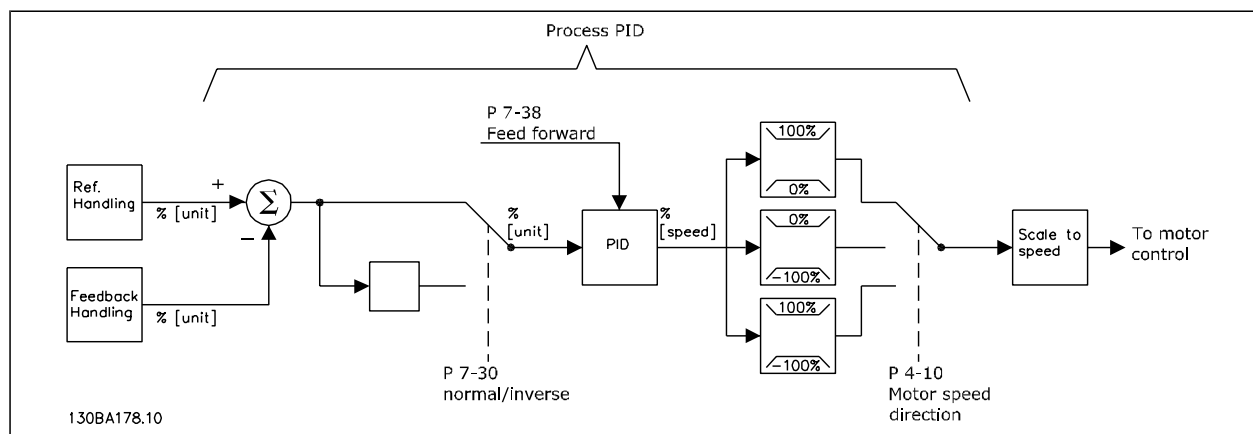

Process PID Control diagram

— Introduction to FC 300 —

The following parameters are relevant for process control.

Parameter	Description of function
Feedback 1 Source Par. 7-20	Select from which source (i.e., analog or pulse input) the process PID should receive its feedback
Feedback 2 Source Par. 7-22	Optional: Determine if (and from where) the process PID should get an additional feedback signal. If an additional feedback source is selected, the two feedback signals will be added together before being used in process PID control.
Normal/inverse control Par. 7-30	Under [0] Normal operation, the process control will respond with an increase of the motor speed if the feedback is getting lower than the reference. In the same situation, but under [1] Inverse operation, the process control will respond with a decreasing motor speed instead.
Anti Windup Par. 7-31	The anti-windup function ensures that when either a frequency limit or a torque limit is reached, the integrator will be set to a gain that corresponds to the actual frequency. This avoids integrating on an error that cannot in any case be compensated for by means of a speed change. This function can be disabled by selecting [0] "Off".
Control Start Value Par. 7-32	In some applications, reaching the required speed/set point can take a very long time. In such applications, it might be an advantage to set a fixed motor speed from the adjustable frequency drive before the process control is activated. This is done by setting a process PID start value (speed) in par. 7-32.
Proportional Gain Par. 7-33	The higher the value, the quicker the control. However, a value that is too large may lead to oscillations.
Integral Time Par. 7-34	Eliminates steady state speed error. Lower value means quick reaction. However, a value that is too small may lead to oscillations.
Differentiation Time Par. 7-35	Provides a gain proportional to the rate of change of the feedback. A setting of zero disables the differentiator.
Differentiator Gain Limit Par. 7-36	If there are quick changes in reference or feedback in a given application - which means that the error changes swiftly - the differentiator may soon become too dominant. This is because it reacts to changes in the error. The quicker the error changes, the stronger the differentiator gain is. The differentiator gain can thus be limited to allow setting of the reasonable differentiation time for slow changes.
Feed Forward Factor Par. 7-38	In applications where there is a good (and approximately linear) correlation between the process reference and the motor speed necessary for obtaining that reference, the feed forward factor can be used to achieve better dynamic performance of the process PID control.
Low-pass Filter Time Par. 5-54 (Pulse term. 29), Par. 5-59 (Pulse term. 33), Par. 6-16 (Analog term 53), Par. 6-26 (Analog term. 54)	<p>If there are oscillations of the current/voltage feedback signal, these can be dampened by means of a low-pass filter. This time constant represents the speed limit of the ripples occurring on the feedback signal.</p> <p>Example: If the low-pass filter has been set to 0.1s, the limit speed will be 10 RAD/sec. (the reciprocal of 0.1 s), corresponding to <math>(10/(2 \times \pi)) = 1.6</math> Hz. This means that all currents/voltages that vary by more than 1.6 oscillations per second will be damped by the filter. The control will only be carried out on a feedback signal that varies by a frequency (speed) of less than 1.6 Hz.</p> <p>The low-pass filter improves steady state performance, but selecting filter time that is too long will deteriorate the dynamic performance of the process PID control.</p>

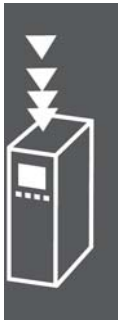

□ **Example of Process PID Control**

The following is an example of process PID control used in a ventilation system:

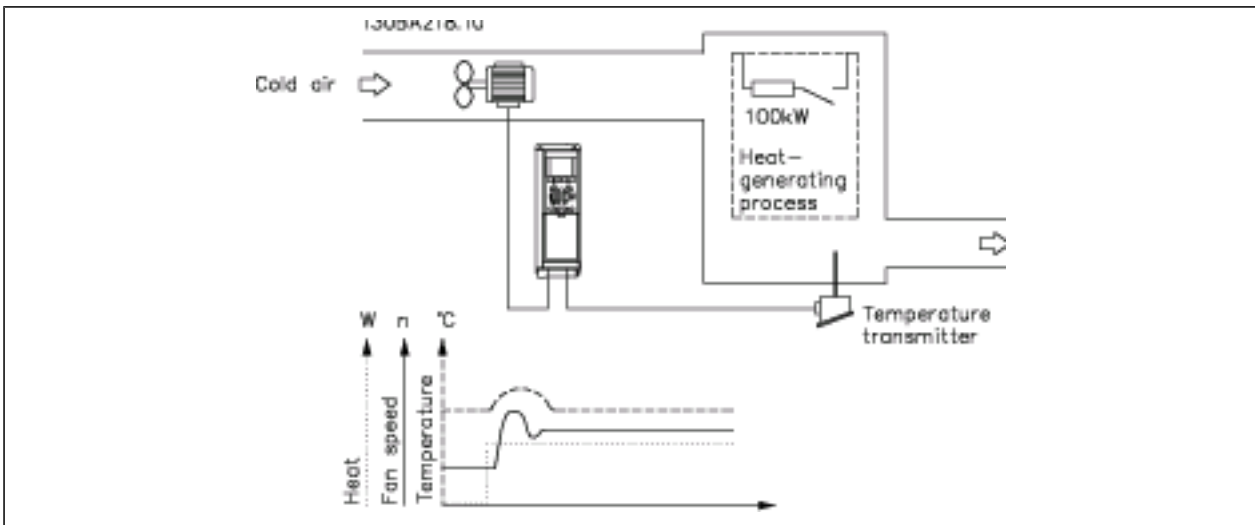

In a ventilation system, the temperature is to be able to be set from 23°-95° F ( -5°-35° C) with a potentiometer of 0-10 Volt. The set temperature must be kept constant, for which purpose the process control is to be used.

The control is of the inverse type, which means that when the temperature increases, the ventilation speed is increased as well, so as to generate more air. When the temperature drops, the speed is reduced. The transmitter used is a temperature sensor with a working range of 14°-104 °F (-10°-+40°C), 4-20 mA. Min. / Max. speed 300 /1,500 RPM.



**NOTE**

The example shows a two-wire transmitter.

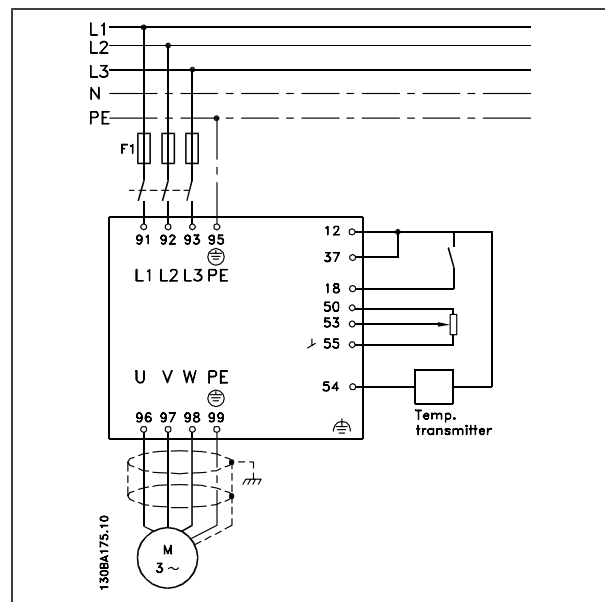

1. Start/Stop via switch connected to terminal 18.
2. Temperature reference via potentiometer (23°-95° F (-5°- +35° C), 0-10 VDC) connected to terminal 53.
3. Temperature feedback via transmitter (14°-104° F (-10°- +40° C), 4-20 mA) connected to terminal 54. Switch S202 set to ON (current input).

## Example of Process PID Control set-up

Function	Par. no.	Setting
Initialize the adjustable frequency drive	14-22	[2] Initialization - perform power cycling - press reset
1) Set motor parameters:		
Set the motor parameters according to nameplate data	1-2*	As stated on motor nameplate
Perform a full <b>Automation Motor Adaptation</b>	1-29	[1] Enable complete AMA
2) Make sure that motor is running in the right direction. When motor is connected to an adjustable frequency drive with straight forward phase order as U - U; V- V; W - W motor shaft usually turns clockwise seen into shaft end.		
Press "Hand On" LCP key. Check shaft direction by applying a manual reference.		
If motor turns opposite of required direction:	4-10	Select correct motor shaft direction.
1. Change motor direction in par. 4-10		
2. Turn off line power - wait for DC link to discharge - switch two of the motor phases		
Set configuration mode.	1-00	[3] Process
Set Local Mode Configuration	1-05	[0] Speed Open-loop
3) Set reference configuration, i.e., the range for reference handling. Set scaling of analog input in par. 6-xx		
Set reference/feedback units	3-01	[140]° F [[60]° C] Unit shown on display
Set min. reference (50° F [10° C])	3-02	23° F [-5° C]
Set max. reference (176° F [80° C])	3-03	95° F [35° C]
If set value is determined from a preset value (array parameter), set other reference sources to No Function.	3-10	[0] 35% $Ref = \frac{P3 - 10(0)}{100} \times ((P3 - 03) - (p3 - 02)) = 24, 5^\circ C$ Par. 3-14 to par. 3-18 [0] = No Function
4) Adjust limits for the adjustable frequency drive:		
Set ramp times to an appropriate value as 20 sec.	3-41	20 sec.
	3-42	20 sec.
Set min. speed limits	4-11	300 RPM
Set motor speed max. limit	4-13	1,500 RPM
Set max. output frequency	4-19	60 Hz
Set S201 or S202 to desired analog input function (Voltage (V) or milli-Amps (I)) NOTE! Switches are sensitive - Make a power cycling keeping default setting of V		
5) Scale analog inputs used for reference and feedback		
Set terminal 53 low voltage	6-10	0 V
Set terminal 53 high voltage	6-11	10 V
Set terminal 54 low feedback value	6-24	23° F [-5° C]
Set terminal 54 high feedback value	6-25	95° F [35° C]
Set feedback source	7-20	[2] Analog input 54
6) Basic PID settings		
Process PID Normal/Inverse	7-30	[0] Normal
Process PID Anti Wind-up	7-31	[1] On
Process PID start speed	7-37	300 rpm
Save parameters to LCP	0-50	[1] All to LCP



Optimization of the process regulator

The basic settings have now been made; all that needs to be done is to optimize the proportional gain, the integration time and the differentiation time (par. 7-33, 7-34, 7-35). In most processes, this can be done by following the guidelines given below.

1. Start the motor
2. Set par. 7-33 (*Proportional Gain*) to 0.3 and increase it until the feedback signal again begins to vary continuously. Then, reduce the value until the feedback signal has stabilized. Now lower the proportional gain by 40-60%.
3. Set par. 7-34 (*Integral Time*) to 20 sec. and reduce the value until the feedback signal again begins to vary continuously. Increase the integration time until the feedback signal stabilizes, followed by an increase of 15-50%.
4. Only use par. 7-35 for very fast-acting systems (differentiation time). The typical value is four times the set integral time. The differentiator should only be used when the setting of the proportional gain and the integral time has been fully optimized. Make sure that oscillations in the feedback signal are sufficiently damped by the low-pass filter on the feedback signal.



**NOTE**

If necessary, start/stop can be activated a number of times in order to provoke a variation of the feedback signal.

□ **Ziegler Nichols Tuning Method**

In order to tune the PID controls of the adjustable frequency drive, several tuning methods can be used. One approach is to use a technique which was developed in the 1950s, but which has stood the test of time and is still used today. This method is known as the Ziegler Nichols tuning method.



**NOTE**

The method described must not be used on applications that could be damaged by the oscillations created by marginally stable control settings.

The criteria for adjusting the parameters are based on evaluating the system at the limit of stability rather than on taking a step response. We increase the proportional gain until we observe continuous oscillations (as measured on the feedback), that is, until the system becomes marginally stable. The corresponding gain ( $K_u$ ) is called the ultimate gain. The period of the oscillation ( $P_u$ ) (called the ultimate period) is determined as shown in Figure 1.

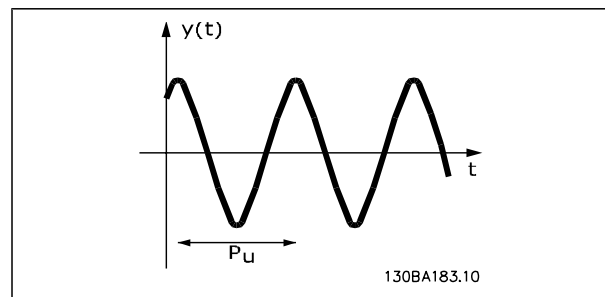

Figure 1: Marginally stable system

$P_u$  should be measured when the amplitude of oscillation is quite small. Then we "back off" from this gain again, as shown in Table 1.

$K_u$  is the gain at which the oscillation is obtained.

Type of Control	Proportional Gain	Integral Time	Differentiation Time
PI-control	$0.45 * K_u$	$0.833 * P_u$	-
PID tight control	$0.6 * K_u$	$0.5 * P_u$	$0.125 * P_u$
PID some overshoot	$0.33 * K_u$	$0.5 * P_u$	$0.33 * P_u$

Table 1: Ziegler Nichols tuning for regulator, based on a stability boundary.

Experience has shown that the control setting according to the Ziegler Nichols rule provides a good closed-loop response for many systems. The process operator can perform final tuning of the control iteratively to yield satisfactory control.

**Step-by-step Description:**

**Step 1:** Select only proportional control, meaning that the integral time is selected to the maximum value, while the differentiation time is selected to zero.

**Step 2:** Increase the value of the proportional gain until the point of instability is reached (sustained oscillations) and the critical value of gain,  $K_u$ , is reached.

**Step 3:** Measure the period of oscillation to obtain the critical time constant,  $P_u$ .

**Step 4:** Use the table above to calculate the necessary PID control parameters.

**General Aspects of EMC Emissions**

Electrical interference is usually conducted at frequencies in the range of 150 kHz to 30 MHz. Airborne interference from the drive system in the range 30 MHz to 1 GHz is generated from the inverter, motor cable, and the motor.

As shown in the illustration below, capacitive currents in the motor cable coupled with a high dV/dt from the motor voltage generate leakage currents.

The use of a shielded motor cable increases the leakage current (see illustration below), because shielded cables have higher capacitance to ground than non-shielded cables. If the leakage current is not filtered, it will cause greater interference on the line power supply in the radio frequency range below approximately 5 MHz. Because the leakage current ( $I_1$ ) is carried back to the unit through the shield ( $I_3$ ), there will in principle only be a small electro-magnetic field ( $I_4$ ) from the shielded motor cable according to the below figure.

The shield reduces the radiated interference but increases the low-frequency interference in the line power supply. The motor cable shield must be connected to the adjustable frequency drive enclosure as well as on the motor enclosure. This is best done by using integrated shield clamps so as to avoid twisted shield ends (pigtailed). These increase the shield impedance at higher frequencies, which reduces the shield effect and increases the leakage current ( $I_4$ ).

If a shielded cable is used for the serial communication bus, relay, control cable, signal interface and brake, the shield must be mounted on the enclosure at both ends. In some situations, however, it will be necessary to break the shield to avoid current loops.

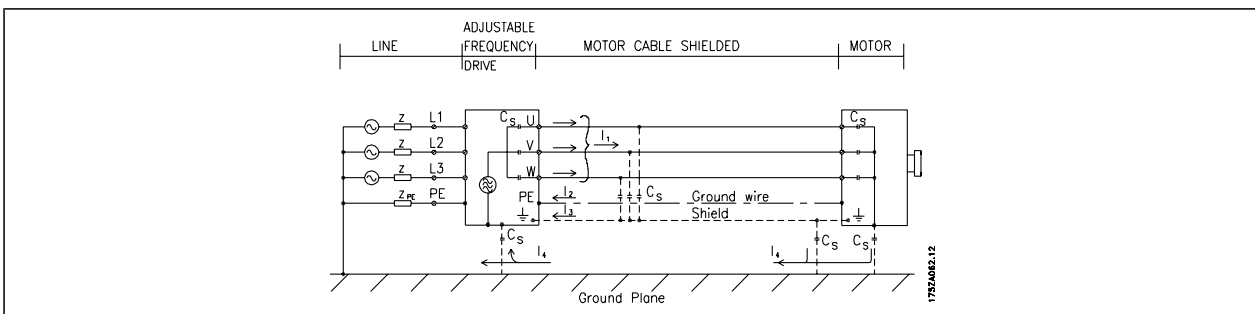

If the shield is to be placed on a mounting plate for the adjustable frequency drive, the mounting plate must be made of metal, because the shield currents have to be conveyed back to the unit. Moreover, ensure good electrical contact from the mounting plate through the mounting screws to the adjustable frequency driver chassis.





**NOTE**

When non-shielded cables are used, some emission requirements are not complied with, although the immunity requirements are observed.

In order to reduce the interference level from the entire system (unit + installation), make motor and brake cables as short as possible. Avoid placing cables with a sensitive signal level alongside motor and brake cables. Radio interference higher than 50 MHz (airborne) is especially generated by the control electronics.

**EMC Test Results (Emission, Immunity)**

The following test results have been obtained using an application with an adjustable frequency drive (with options, if relevant), a shielded control cable, a control box with potentiometer, as well as a motor and a shielded motor cable.

Setup	Conducted emission			Radiated emission	
	Industrial environment		Housing, trades, and light industries	Industrial environment	Housing, trades, and light industries
	EN 55011 Class A2	EN 55011 Class A1	EN 55011 Class B	EN 55011 Class A1	EN 55011 Class B
<b>FC 301/FC 302 (H2)</b>					
0-5 HP (0-3.7 kW) 200-240 V	16.4 ft [5 m]	No	No	No	No
0-10 HP (0-7.5 kW) 380-480/500 V	16.4 ft [5 m]	No	No	No	No
<b>FC 301 (H1)</b>					
0-5 HP (0-3.7 kW) 200-240 V		164 ft [50 m]			
0-10 HP (0-7.5 kW) 380-500 V	246 ft [75 m]	164 ft [50 m]	32.8 ft [10 m]	Yes	No
<b>FC 301 (H3)</b>					
0-2 hp [0-1.5 kW] 200-240 V	164 ft [50 m]	82 ft [25 m]	8.2 ft [2.5 m]	Yes	No
0-2 hp [0-1.5 kW] 380-480 V	164 ft [50 m]	82 ft [25 m]	8.2 ft [2.5 m]	Yes	No
<b>FC 302 (H1)</b>					
0-5 HP (0-3.7 kW) 200-240 V		492 ft [150 m]			
0-10 HP (0-7.5 kW) 380-500 V	492 ft [150 m]	492 ft [150 m]	164 ft [50 m]	Yes	No
<b>FC 301/FC 302 (H2)</b>					
15-30 hp [11-22 kW] 380-480/500 V	82 ft [25 m]	No	No	No	No
<b>FC 301 (H1)</b>					
15-30 hp [11-22 kW] 380-480 V	246 ft [75 m]	164 ft [50 m]	32.8 ft [10 m]	Yes	No
<b>FC 302 (H1)</b>					
15-30 hp [11-22 kW] 380-500 V	492 ft [150 m]	492 ft [150 m]	164 ft [50 m]	Yes	No
<b>FC 302 (HX)</b>					
1-10 hp [0.75-7.5 kW] 550-600 V	No	No	No	No	No

- HX, H1, H2 or H3 is defined in the type code pos. 16 - 17 for EMC filters
- HX - No EMC filters build in the adjustable frequency drive (600 V units only)
- H1 - Integrated EMC filter. Fulfill Class A1/B
- H2 - No additional EMC filter. Fulfill Class A2
- H3 - Integrated EMC filter. Fulfill class A1/B (Enclosure type A1 only)



□ **Required Compliance Levels**

Standard / environment	Housing, trades, and light industries		Industrial environment	
	Conducted	Radiated	Conducted	Radiated
IEC 61000-6-3 (generic)	Class B	Class B		
IEC 61000-6-4			Class A1	Class A1
EN 61800-3 (restricted)	Class A1	Class A1	Class A1	Class A1
EN 61800-3 (unrestricted)	Class B	Class B	Class A2	Class A2

EN 55011: Threshold values and measuring methods for radio interference from industrial, scientific and medical (ISM) high-frequency equipment.

Class A1: Equipment used in a public supply network. Restricted distribution.

Class A2: Equipment used in a public supply network.

Class B1: Equipment used in areas with a public supply network (residential, commerce, and light industries). Unrestricted distribution.



□ **EMC Immunity**

In order to document immunity against electrical interference from electrical phenomena, the following immunity tests have been made on a system consisting of an adjustable frequency drive (with options, if relevant), a shielded control cable and a control box with potentiometer, motor cable and motor.

The tests were performed in accordance with the following basic standards:

- **EN 61000-4-2 (IEC 61000-4-2): Electrostatic discharge (ESD)** Simulation of electrostatic discharge from human beings.
- **EN 61000-4-3 (IEC 61000-4-3): Incoming electromagnetic field radiation, amplitude modulated** Simulation of the effects of radar and radio communication equipment as well as mobile communications.
- **Electrical interference Electrical interference** Simulation of interference caused by switching with a contactor, relays or similar devices.
- **EN 61000-4-5 (IEC 61000-4-5): Surge transients** Simulation of transients caused, e.g., by lightning striking near installations.
- **EN 61000-4-6 (IEC 61000-4-6): RF Common mode** Simulation of the effects of radio-transmitting equipment connected to connection cables.

See following EMC immunity form.

**Immunity continued**

FC 301/FC 302; 200-240 V, 380-500 V

Basic standard	Burst IEC 61000-4-4	Surge IEC 61000-4-5	ESD IEC 61000-4-2	Radiated electromagnetic field IEC 61000-4-3	RF common mode voltage IEC 61000-4-6
Acceptance criterion	B	B	B	A	A
Line	4 kV CM	2 kV/2 Ω DM 4 kV/12 Ω CM	—	—	10 V <sub>RMS</sub>
Motor	4 kV CM	4 kV/2 Ω <sup>1)</sup>	—	—	10 V <sub>RMS</sub>
Brake	4 kV CM	4 kV/2 Ω <sup>1)</sup>	—	—	10 V <sub>RMS</sub>
Load sharing	4 kV CM	4 kV/2 Ω <sup>1)</sup>	—	—	10 V <sub>RMS</sub>
Control wires	2 kV CM	2 kV/2 Ω <sup>1)</sup>	—	—	10 V <sub>RMS</sub>
Standard bus	2 kV CM	2 kV/2 Ω <sup>1)</sup>	—	—	10 V <sub>RMS</sub>
Relay wires	2 kV CM	2 kV/2 Ω <sup>1)</sup>	—	—	10 V <sub>RMS</sub>
Application and serial communication options	2 kV CM	2 kV/2 Ω <sup>1)</sup>	—	—	10 V <sub>RMS</sub>
LCP cable	2 kV CM	2 kV/2 Ω <sup>1)</sup>	—	—	10 V <sub>RMS</sub>
External 24 V DC	2 kV CM	0.5 kV/2 Ω DM 1 kV/12 Ω CM	—	—	10 V <sub>RMS</sub>
Enclosure	—	—	8 kV AD 6 kV CD	10 V/m	—

AD: Air Discharge  
 CD: Contact Discharge  
 CM: Common mode  
 DM: Differential mode

1. Injection on cable shield.



**Galvanic Isolation (PELV)**

PELV offers protection by way of extra low voltage. Protection against electric shock is ensured when the electrical supply is of the PELV type and the installation is made as described in local/national regulations on PELV supplies.

All control terminals and relay terminals 01-03/04-06 comply with PELV (Protective Extra Low Voltage) (Does not apply to 525-600 V units and at grounded Delta leg above 300 V).

Galvanic (ensured) isolation is obtained by fulfilling requirements for higher isolation and by providing the relevant creepage/clearance distances. These requirements are described in the EN 61800-5-1 standard.

The components that make up the electrical isolation, as described below, also comply with the requirements for higher isolation and the relevant test as described in EN 61800-5-1.

The PELV galvanic isolation can be shown in six locations (see illustration):

In order to maintain PELV, all connections made to the control terminals must be PELV; for example, the thermistor must be reinforced/double insulated.

1. Power supply (SMPS) incl. signal isolation of U<sub>DC</sub>, indicating the intermediate current voltage.
2. Gate drive that runs the IGBTs (trigger transformers/opto-couplers).
3. Current transducers.
4. Opto-coupler, brake module.
5. Internal soft-charge, RFI and temperature measurement circuits.
6. Custom relays.

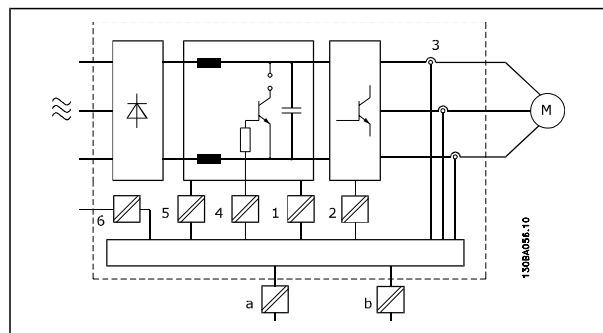

Galvanic isolation

The functional galvanic isolation (a and b on drawing) is for the 24 V backup option and for the RS-485 standard bus interface.

□ **Ground Leakage Current**



**Warning:**

Touching the electrical parts may be fatal - even after the equipment has been disconnected from line power.

Also make sure that other voltage inputs have been disconnected, such as load sharing (linkage of DC intermediate circuit), as well as the motor connection for kinetic backup.

Using VLT AutomationDrive FC 300: wait at least 15 minutes.

A shorter time is allowed only if indicated on the nameplate for the specific unit.

**Leakage Current**

The ground leakage current from the FC 300 exceeds 3.5 mA. To ensure that the ground cable has a good mechanical connection to the ground connection (terminal 95), the cable cross-section must be at least 0.016 in.<sup>2</sup> [10 mm<sup>2</sup>] or have 2 rated ground wires terminated separately.

**Residual Current Device**

This product can cause DC current in the protective conductor. Where a residual current device (RCD) is used for extra protection, only an RCD of Type B (time delayed) shall be used on the supply side of this product. See also RCD Application Note MN.90.GX.02.

Protective grounding of the adjustable frequency drive and the use of RCDs must always follow national and local regulations.



□ **Selection of Brake Resistor**

To handle higher demands by generative braking, a brake resistor is necessary. Using a brake resistor ensures that the energy is absorbed in the brake resistor and not in the adjustable frequency drive.

If the amount of kinetic energy transferred to the resistor in each braking period is not known, the average power can be calculated on the basis of the cycle time and braking time, also called intermitted duty cycle. The resistor intermittent duty cycle is an indication of the duty cycle at which the resistor is active. The figure below shows a typical braking cycle.



**NOTE**

Motor suppliers often use S5 when stating the permissible load, which is an expression of intermittent duty cycle.

The intermittent duty cycle for the resistor is calculated as follows:

$$Duty\ cycle = t_b/T$$

T = cycle time in seconds

t<sub>b</sub> is the braking time in seconds (of the cycle time)

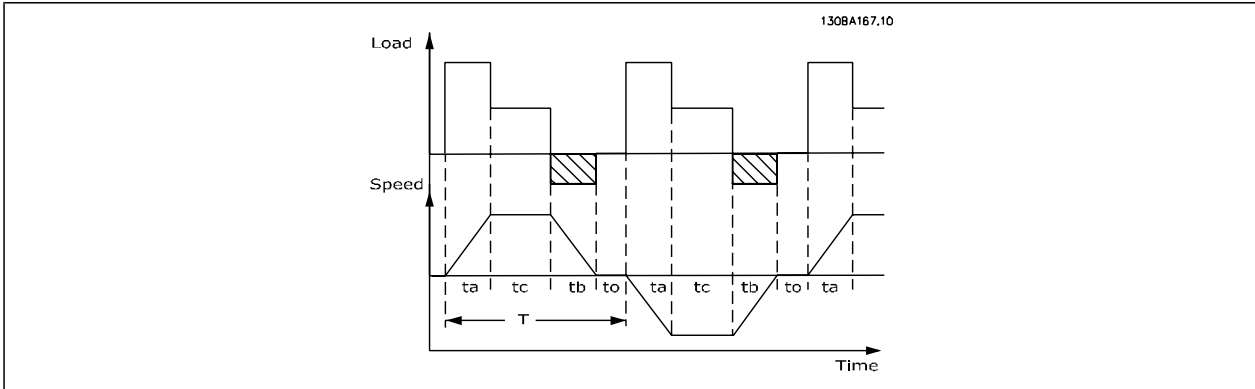

Danfoss offers brake resistors with duty cycle of 5%, 10% and 40%. If a 10% duty cycle is applied, the brake resistors are able to absorb braking energy for 10% of the cycle time. The remaining 90% of the cycle time will be used on dissipating excess heat.

The max. permissible load on the brake resistor is stated as a peak power at a given intermittent duty cycle and can be calculated as:

The brake resistance is calculated as shown:

$$R_{br} [\Omega] = \frac{U_{dc}^2}{P_{peak}}$$

where

$$P_{peak} = P_{motor} \times M_{br} \times \eta_{motor} \times \eta_{VLT} [W]$$

As can be seen, the brake resistance depends on the intermediate circuit voltage ( $U_{dc}$ ).

The FC 301 and FC 302 brake function is settled in 4 areas of the line power:

Size	Brake active	Warning before cut out	Cut out (trip)
FC 301 / 302 3 x 200-240 V	390 V (UDC)	405 V	410 V
FC 301 3 x 380-480 V	778 V	810 V	820 V
FC 302 3 x 380-500 V	810 V	840 V	850 V
FC 302 3 x 525-600 V	943 V	965 V	975 V

**NOTE**

Make sure that the brake resistor can cope with a voltage of 410 V, 820 V, 850 V or 975 V - unless Danfoss brake resistors are used.

Danfoss recommends the brake resistance  $R_{rec}$ , i.e., one that guarantees that the adjustable frequency drive is able to brake at the highest braking torque ( $M_{br(\%)}$ ) of 160%. The formula can be written as:

$$R_{rec} [\Omega] = \frac{U_{dc}^2 \times 100}{P_{motor} \times M_{br} (\%) \times \eta_{VLT} \times \eta_{motor}}$$



$\eta_{motor}$  is typically at 0.90

$\eta_{VLT}$  is typically at 0.98

For 200 V, 480 V, 500 V and 600 V adjustable frequency drives,  $R_{rec}$  at 160% braking torque is written as:

$$200V : R_{rec} = \frac{107780}{P_{motor}} [\Omega]$$

$$480V : R_{rec} = \frac{375300}{P_{motor}} [\Omega] \text{ 1)}$$

$$480V : R_{rec} = \frac{428914}{P_{motor}} [\Omega] \text{ 2)}$$

$$500V : R_{rec} = \frac{464923}{P_{motor}} [\Omega]$$

$$600V : R_{rec} = \frac{630137}{P_{motor}} [\Omega]$$

$$690V : R_{rec} = \frac{832664}{P_{motor}} [\Omega]$$

1) For FC 300 adjustable frequency drives  $\leq 7.5$  kW shaft output

2) For FC 300 adjustable frequency drives  $> 7.5$  kW shaft output

**NOTE**

The resistor brake circuit resistance selected should not be higher than that recommended by Danfoss. If a brake resistor with a higher ohmic value is selected, the 160% braking torque may not be achieved because there is a risk that the adjustable frequency drive cuts out for safety reasons.

**NOTE**

If a short circuit in the brake transistor occurs, power dissipation in the brake resistor is only prevented by using a line switch or contactor to disconnect the AC line for the adjustable frequency drive. (The contactor can be controlled by the adjustable frequency drive).

**NOTE**

Do not touch the brake resistor, as it can get very hot during/after braking.

#### □ Control with Brake Function

The brake is to limit the voltage in the intermediate circuit when the motor acts as a generator. This occurs, for example, when the load drives the motor and the power accumulates on the DC link. The brake is built up as a chopper circuit with the connection of an external brake resistor. Placing the brake resistor externally offers the following advantages:

- The brake resistor can be selected on the basis of the application in question.
- The braking energy can be dissipated outside the control panel, i.e., where the energy can be utilized.
- The electronics of the adjustable frequency drive will not overheat if the brake resistor is overloaded.

The brake is protected against short-circuiting of the brake resistor, and the brake transistor is monitored to ensure that short-circuiting of the transistor is detected. A relay/digital output can be used for protecting the brake resistor against overloading in connection with a fault in the adjustable frequency drive. In addition, the brake makes it possible to read out the momentary power and the mean power for the last 120 seconds. The brake can also monitor the power energizing and ensure that it does not exceed a limit set in par. 2-12. In par. 2-13, select the function to carry out when the power transmitted to the brake resistor exceeds the limit set in par. 2-12.

**NOTE**

Monitoring the braking energy is not a safety function; a thermal switch is required for that purpose. The brake resistor circuit is not protected against ground leakage.

*Overvoltage control (OVC)* (exclusive brake resistor) can be selected as an alternative brake function in par. 2-17. This function is active for all units. The function ensures that a trip can be avoided if the DC link voltage increases. This is done by increasing the output frequency to limit the voltage from the DC link. It is a very useful function if, for example, the ramp-down time is too short because tripping the adjustable frequency drive is avoided. In this situation, the ramp-down time is extended.

#### □ Mechanical Brakecontrol

For hoisting applications, it is necessary to be able to control an electro-magnetic brake. For controlling the brake, a relay output (relay1 or relay2) or a programmed digital output (terminal 27 or 29) is required. Normally, this output must be closed for as long as the adjustable frequency drive is unable to 'hold' the motor, due to a load that is too large, for example. In par. 5-40 (Array parameter), par. 5-30, or par. 5-31 (digital output 27 or 29), select *Mechanical brake control* [32] for applications with an electro-magnetic brake.

When *Mechanical brake control* [32] is selected, the mechanical brake relay stays closed during start until the output current is above the level selected in par. 2-20 *Release Brake Current*. During stop, the mechanical brake will close when the speed is below the level selected in par. 2-21 *Activate Brake Speed [RPM]*. If the adjustable frequency drive is brought into an alarm condition, i.e., an overvoltage situation, the mechanical brake immediately cuts in. This is also the case during safe stop.

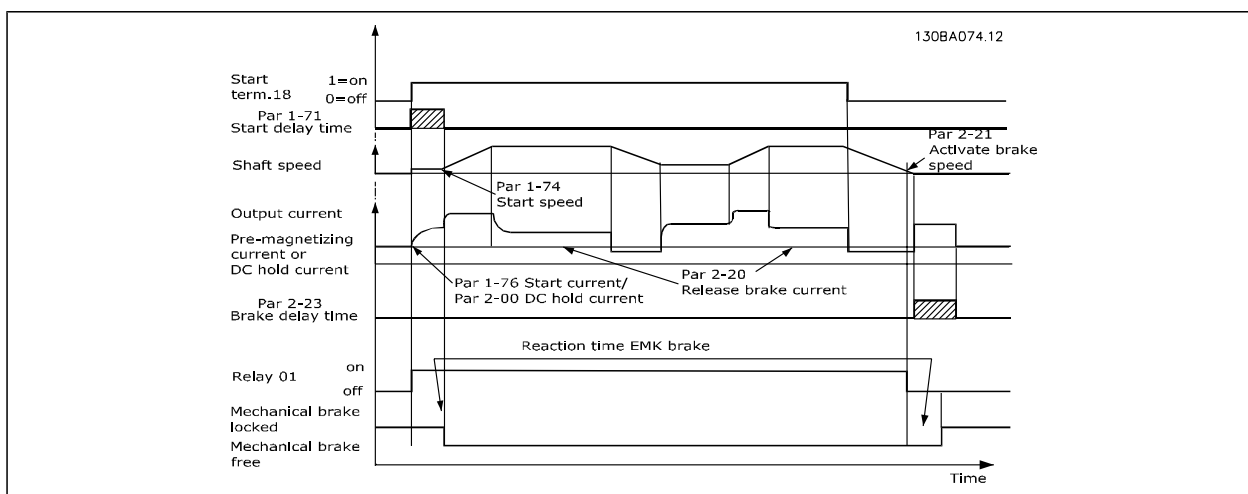

### Step-by-step Description

In hoisting/lowering applications, it must be possible to control an electro-mechanical brake.

- To control the mechanical brake, any relay output or digital output (terminal 27 or 29) can be used. If necessary, use a suitable contactor.
- Ensure that the output is switched off as long as the adjustable frequency drive is unable to drive the motor, such as when the load is too heavy or the motor has not been mounted, for example.
- Select *Mechanical brake control* [32] in par. 5-4\* (or in par. 5-3\*) before connecting the mechanical brake.
- The brake is released when the motor current exceeds the preset value found in par. 2-20.
- The brake is engaged when the output frequency is less than the frequency found in par. 2-21 or 2-22, and only if the adjustable frequency drive carries out a stop command.



#### NOTE

For vertical lifting or hoisting applications, ensuring that the load can be stopped in case of an emergency or the malfunction of a single part (a contactor, e.g.) is strongly recommended. If the adjustable frequency drive is in alarm mode or in an overvoltage situation, the mechanical brake cuts in.



#### NOTE

For hoisting applications, make sure that the torque limits in par. 4-16 and 4-17 are set lower than the current limit in par. 4-18. It is also recommended to set par. 14-25, *Trip Delay at Torque Limit* to "0", par. 14-26, *Trip Delay at Inverter Fault* to "0" and par. 14-10, *Line Failure* to "[3], *Coasting*".

### □ Hoist Mechanical Brake

The VLT Automation Drive FC 300 features a mechanical brake control specifically designed for hoisting applications. The main difference compared to the regular mechanical brake control, where a relay function monitoring the output current is used, is that the hoist mechanical brake function has direct control over the brake relay. This means that instead of setting a current for release of the brake, the torque applied against the closed brake before release is defined. Because the torque is defined directly the setup is more straightforward for hoisting applications.

By using the Proportional Gain Boost (par. 2-28), a quicker control when releasing the brake can be obtained. The hoist mechanical brake strategy is based on a 3-step sequence, where motor control and brake release are synchronized in order to obtain the smoothest possible brake release:

1. **Pre-magnetize the motor**

In order to ensure that there is a hold on the motor, and to verify that it is mounted correctly, the motor is first pre-magnetized.

2. **Apply torque against the closed brake**

When the load is held by the mechanical brake, its size cannot be determined, only its direction. The moment the brake opens, the load must be taken over by the motor. To facilitate the take-over, a user defined torque, set in par. 2-26, is applied in hoisting direction. This will be used to initialize the speed controller that will finally take over the load. In order to reduce wear on the gearbox due to backlash, the torque is ramped up.

3. **Release brake**

When the torque reaches the value set in par. 2-26 *Torque Ref*, the brake is released. The value set in par. 2-25 *Brake Release Time* determines the delay before the load is released. In order to react as quickly as possible on the load-step that follows upon brake release, the speed-PID control can be boosted by increasing the proportional gain.

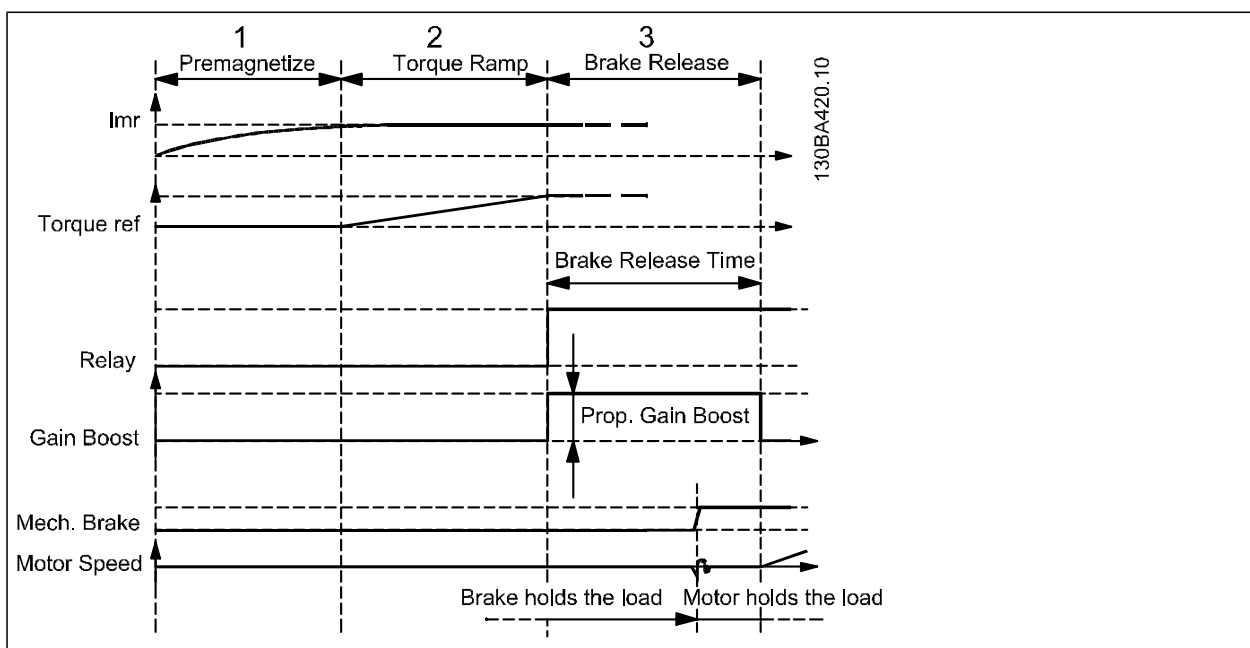

Brake release sequence for hoist mechanical brake control

□ **Cabling**

EMC (twisted cables/shielding)

To reduce the electrical noise from the wires between the brake resistor and the adjustable frequency drive, the wires must be twisted.

For enhanced EMC performance, a metal shield can be used.

□ **Smart Logic Control**

The Smart Logic Control (SLC) is essentially a sequence of user defined actions (see par. 13-52) executed by the SLC when the associated user defined *event* (see par. 13-51) is evaluated as TRUE by the SLC.



*Events* and *actions* are each numbered and linked in pairs called states. This means that when *event [1]* is fulfilled (attains the value TRUE), *action [1]* is executed. After this, the conditions of *event [2]* will be evaluated and if evaluated TRUE, *action [2]* will be executed and so on. Events and actions are placed in array parameters.

Only one *event* will be evaluated at any time. If an *event* is evaluated as FALSE, nothing happens (in the SLC) during the present scan interval and no other *events* will be evaluated. This means that when the SLC starts, it evaluates *event [1]* (and only *event [1]*) each scan interval. Only when *event [1]* is evaluated TRUE, does the SLC execute *action [1]* and begin evaluating *event [2]*.

It is possible to program from 0 to 20 *events* and *actions*. When the last *event / action* has been executed, the sequence starts over again from *event [1] / action [1]*. The illustration shows an example with three *events / actions*:

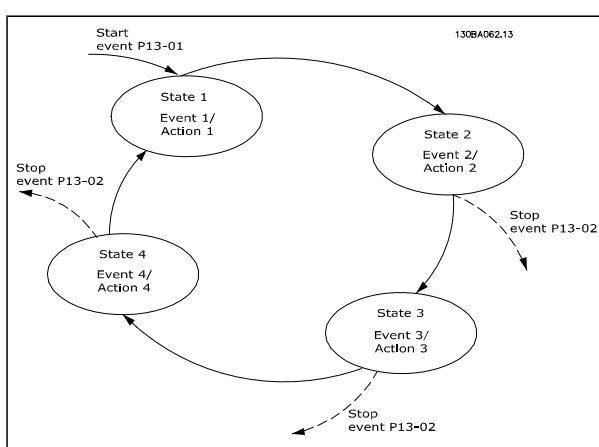

### Short Circuit (Motor Phase – Phase)

The adjustable frequency drive is protected against short circuits by means of current measurement in each of the three motor phases or in the DC link. A short circuit between two output phases will cause an overcurrent in the inverter. The inverter will be turned off individually when the short circuit current exceeds the permitted value (Alarm 16 Trip Lock).

To protect the drive against a short circuit at the load sharing and brake outputs, please see the design guidelines.

### Switching on the Output

Switching on the output between the motor and the adjustable frequency drive is fully permitted. You cannot damage the adjustable frequency drive in any way by switching on the output. However, fault messages may appear.

### Motor-generated Overvoltage

The voltage in the intermediate circuit is increased when the motor acts as a generator. This occurs in the following cases:

1. The load drives the motor (at constant output frequency from the adjustable frequency drive), i.e., the load generates energy.
2. During deceleration ("ramp-down"), if the moment of inertia is high the friction is low and the ramp-down time is too short for the energy to be dissipated as a loss in the adjustable frequency drive, the motor and the installation.

3. Incorrect slip compensation setting may cause higher DC link voltage.

The control unit may attempt to correct the ramp if possible (par. 2-17 *Overvoltage Control*).

The inverter turns off to protect the transistors and the intermediate circuit capacitors when a certain voltage level is reached.

See par. 2-10 and par. 2-17 to select the method used for controlling the intermediate circuit voltage level.

**Line Drop-out**

During a line drop-out, the adjustable frequency drive keeps running until the intermediate circuit voltage drops below the minimum stop level, which is typically 15% below the adjustable frequency drive's lowest rated supply voltage.

The line voltage before the drop-out and the motor load determine how long it takes for the inverter to coast.

**Static Overload in VVC<sup>plus</sup> mode**

When the adjustable frequency drive is overloaded (the torque limit in par. 4-16/4-17 is reached), the control reduces the output frequency to reduce the load.

If the overload is excessive, a current may occur that makes the adjustable frequency drive cut out after approximately 5-10 s.

Operation within the torque limit is limited in time (0-60 s) in par. 14-25.



□ **Motor Thermal Protection**

The motor temperature is calculated on the basis of motor current, output frequency, and time or thermistor. See par. 1-90 in the chapter *How to Program*.

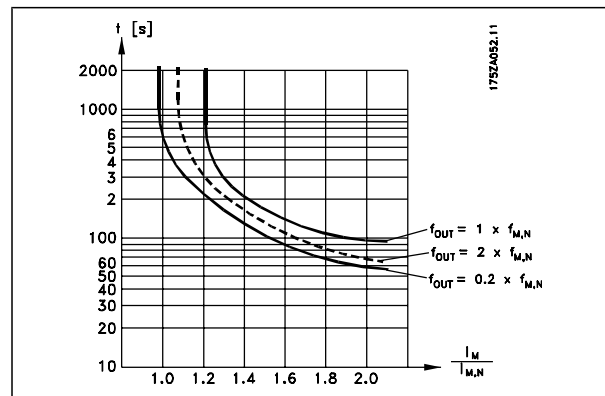

□ **Safe Stop of FC 300**

The FC 302, and also the FC301 in A1 enclosure, can perform the safety function *Safe Torque Off* (As defined by draft CD IEC 61800-5-2) or *Stop Category 0* (as defined in EN 60204-1).

FC 301 A1 enclosure: When Safe Stop is included in the drive, position 18 of Type Code must be either T or U. If position 18 is B or X, Safe Stop Terminal 37 is not included!

Example:

Type Code for FC 301 A1 with Safe Stop: FC-301PK75T4**Z20**H4TGCXXXSXXXXA0BXCXXXXD0

It is designed and deemed suitable for the requirements of Safety Category 3 in EN 954-1. This functionality is called Safe Stop. Prior to integrating and using Safe Stop in an installation, a thorough risk analysis must be carried out on the installation in order to determine whether the Safe Stop functionality and safety category are appropriate and sufficient. In order to install and use the Safe Stop function in accordance with the requirements of Safety Category 3 in EN 954-1, the related information and instruc-

— Introduction to FC 300 —

tions of the FC 300 Design Guide MG.33.BX.YY must be followed! The information and instructions contained in the Instruction Manual are not sufficient for a correct and safe use of the Safe Stop functionality!



**□ Safe Stop Installation (FC 302 and FC 301 - A1 enclosure only)**

To carry out an installation of a Category 0 Stop (EN60204) in accordance with Safety Category 3 (EN954-1), follow these instructions:

1. The bridge (jumper) between Terminal 37 and 24 V DC must be removed. Cutting or breaking the jumper is not sufficient. Remove it entirely to avoid short-circuiting. See jumper on illustration.
2. Connect terminal 37 to 24 V DC by a short circuit-protected cable. The 24 V DC voltage supply must be interruptible by an EN954-1 category 3 circuit interrupt device. If the interrupt device and the adjustable frequency drive are placed in the same installation panel, you can use a regular cable instead of a protected one.

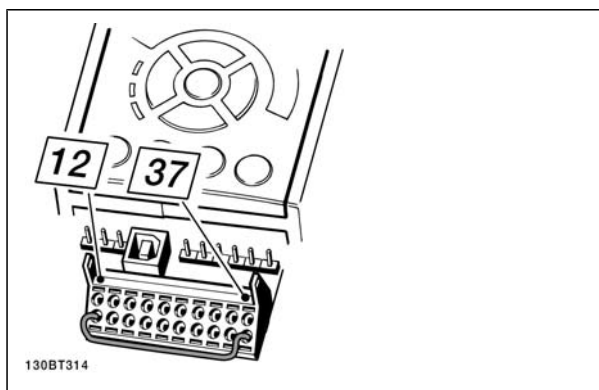

Bridge jumper between terminal 37 and 24 VDC

The illustration below shows a Stopping Category 0 (EN 60204-1) with safety Category 3 (EN 954-1). The circuit interruption is caused by an opening door contact. The illustration also shows how to connect a non-safety-related hardware coast.

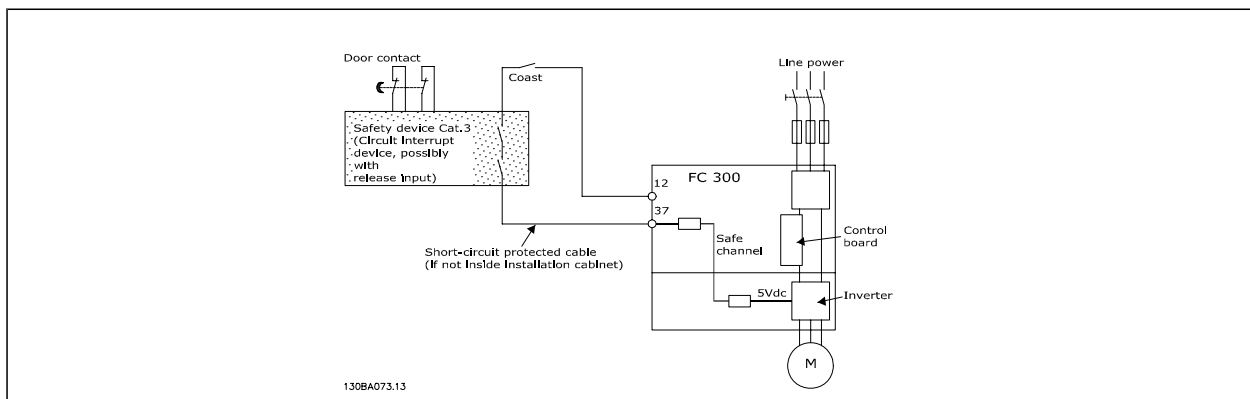

Illustration of the essential aspects of an installation to achieve a Stopping Category 0 (EN 60204-1) with safety Category 3 (EN 954-1).

#### □ Safe Stop Commissioning Test

After installation and before first operation, perform a commissioning test of an installation or application making use of FC 300 Safe Stop.

Moreover, perform the test after each modification of the installation or application, which the FC 300 Safe Stop is part of.

The commissioning test:

1. Remove the 24 V DC voltage supply to terminal 37 by the interrupt device while the motor is driven by the FC 302 (i.e., line supply is not interrupted). The test step is passed if the motor reacts with a coast and the mechanical brake (if connected) is activated.
2. Then send reset signal (via Bus, Digital I/O, or [Reset] key). The test step is passed if the motor remains in the safe stop state, and the mechanical brake (if connected) remains activated.
3. Then reapply 24 V DC to terminal 37. The test step is passed if the motor remains in the coasted state, and the mechanical brake (if connected) remains activated.
4. Then send reset signal (via Bus, Digital I/O, or [Reset] key). The test step is passed if the motor becomes operational again.

5. The commissioning test is passed if all four test steps are passed.

**NOTE**

The safe stop function on the FC 302 can be used for asynchronous and synchronous motors. It may happen that two faults occur in the adjustable frequency drive's power semiconductor. When using synchronous motors, this may cause a residual rotation. The rotation can be calculated to  $\text{Angle} = 360 / (\text{Number of Poles})$ . The application using synchronous motors must take this into consideration and ensure that this is not a safety-critical issue. This situation is not relevant for asynchronous motors.

**NOTE**

In order to use the safe stop functionality in conformance with the requirements of EN-954-1 Category 3, a number of conditions must be fulfilled by the installation of safe stop. Please see section *Safe Stop Installation* for further information.

**NOTE**

The adjustable frequency drive does not provide safety-related protection against unintended or malicious voltage supply to terminal 37 and subsequent reset. Provide this protection via the interrupt device, at the application level, or organizational level. For more information - see section *Safe Stop Installation*.

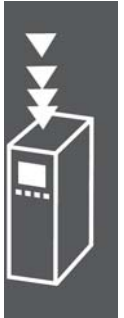



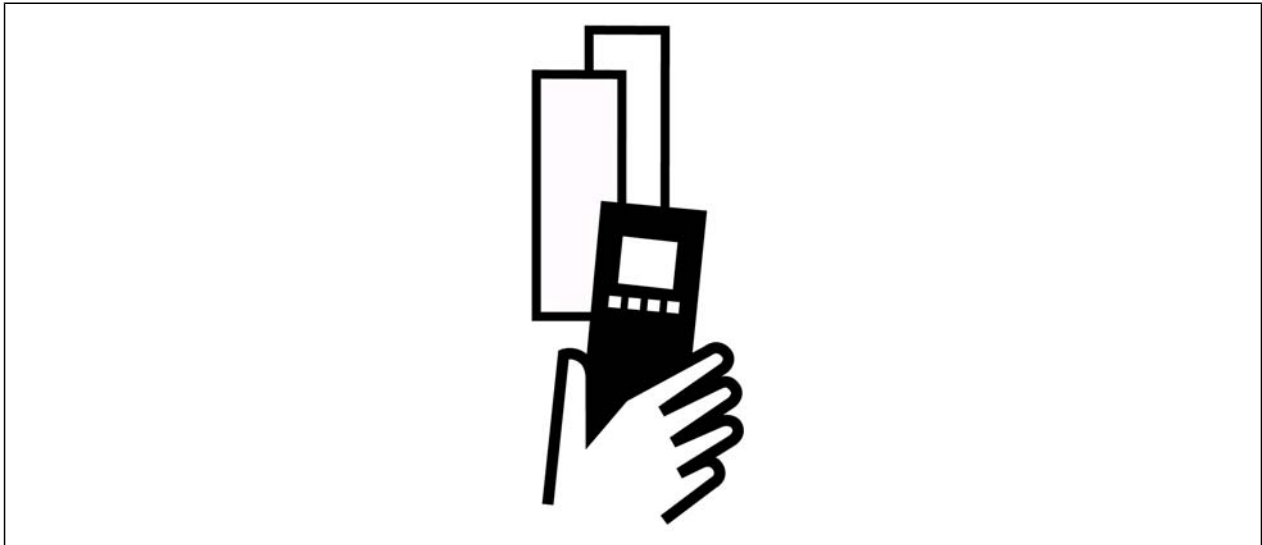

## FC 300 Selection

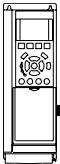

### Electrical Data

<b>Line Supply 3 x 200-240 VAC</b>											
FC 301/FC 302											
	PK25	PK37	PK55	PK75	P1K1	P1K5	P2K2	P3K0	P3K7		
Typical Shaft Output [kW]	0.25	0.37	0.55	0.75	1.1	1.5	2.2	3	3.7		
Enclosure IP 20/IP 21	A2	A2	A2	A2	A2	A2	A2	A3	A3		
Enclosure IP 20 (FC 301 only)	A1	A1	A1	A1	A1	A1	-	-	-		
Enclosure IP 55	A5	A5	A5	A5	A5	A5	A5	A5	A5		
<b>Output current</b>											
	Continuous (3 x 200-240 V) [A]	1.8	2.4	3.5	4.6	6.6	7.5	10.6	12.5	16.7	
	Intermittent (3 x 200-240 V) [A]	2.9	3.8	5.6	7.4	10.6	12.0	17.0	20.0	26.7	
	Continuous KVA (208 V AC) [KVA]	0.65	0.86	1.26	1.66	2.38	2.70	3.82	4.50	6.00	
	Max. cable size (line power, motor, brake) [AWG] <sup>2)</sup> [mm <sup>2</sup> ]	24 - 10 AWG 0.00031-0.0062 in. [0.2-4 mm] <sup>2</sup>									
<b>Max. input current</b>											
	Continuous (3 x 200-240 V) [A]	1.6	2.2	3.2	4.1	5.9	6.8	9.5	11.3	15.0	
	Intermittent (3 x 200-240 V) [A]	2.6	3.5	5.1	6.6	9.4	10.9	15.2	18.1	24.0	
	Max. pre-fuses <sup>1)</sup> [A]	10	10	10	10	20	20	20	32	32	
	<b>Environment</b>										
	Estimated power loss at rated max. load [W] <sup>4)</sup>	21	29	42	54	63	82	116	155	185	
Weight, enclosure IP20 [kg]	4.7	4.7	4.8	4.8	4.9	4.9	4.9	6.6	6.6		
A1 (IP 20)	2.7	2.7	2.7	2.7	2.7	2.7	-	-	-		
Efficiency <sup>4)</sup>	0.94	0.94	0.95	0.95	0.96	0.96	0.96	0.96	0.96		

0.33-4 hp [0.25-3.7 kW] only available as 160% high overload.



Line Supply 3 x 200-240 VAC FC 301/FC 302 High/ Normal Load*		P5K5		P7K5		P11K		P15K		P18K5		P22K		P30K		P37K	
		HO	NO	HO	NO	HO	NO	HO	NO	HO	NO	HO	NO	HO	NO	HO	NO
Typical Shaft Output [kW]	5.5	7.5	7.5	11	11	15	15	18.5	18.5	22	22	22	30	30	37	37	45
Enclosure IP21	B1	B1	B1	B1	B2	B2	C1	C1	C1	C1	C1	C1	C1	C2	C2	C2	C2
Enclosure IP55	B1	B1	B1	B1	B1	B1	C1	C1	C1	C1	C1	C1	C1	C2	C2	C2	C2
<b>Output current</b>																	
Continuous (3 x 200-240 V) [A]	24.2	30.8	30.8	46.2	46.2	59.4	59.4	74.8	74.8	88	88	88	115	115	143	143	170
Intermittent (60 sec overload) (3 x 200-240 V) [A]	38.7	33.9	49.3	50.8	73.9	65.3	89.1	82.3	112	96.8	132	127	173	157	215	187	187
Continuous KVA (208 V AC) [KVA]	8.7	11.1	11.1	16.6	16.6	21.4	21.4	26.9	26.9	31.7	31.7	31.7	41.4	41.4	51.5	51.5	61.2
<b>Max. input current</b>																	
Continuous (3 x 200-240 V) [A]	22	28	28	42	42	54	54	68	68	80	80	80	104	104	130	130	154
Intermittent (60 sec overload) (3 x 200-240 V) [A]	35.2	30.8	44.8	46.2	67.2	59.4	81	74.8	102	88	120	114	156	143	195	169	169
Max. cable size [mm <sup>2</sup> / AWG] <sup>2)</sup>																	
Max. pre-fuses [A] <sub>1</sub>	63	63	63	80	80	125	125	125	125	125	160	160	200	200	250	250	250
Estimated power loss at rated max. load [W] <sup>4)</sup>	239	310	371	514	463	602	624	737	740	845	874	1140	1143	1353	1400	1636	1636
Weight, enclosure IP21, IP55 [kg]	23	23	23	27	27	45	45	45	45	45	45	45	65	65	65	65	65
Efficiency <sup>4)</sup>	0.964	0.964	0.959	0.964	0.964	0.964	0.964	0.964	0.964	0.965	0.965	0.965	0.966	0.966	0.966	0.966	0.966

\* High overload = 160% torque during 60 s, Normal overload = 110% torque during 60 s

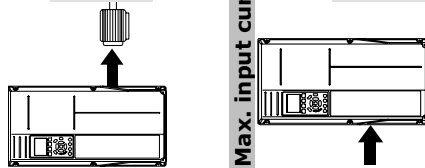



<b>Line Supply 3 x 380-500 VAC (FC 302), 3 x 380-480 VAC (FC 301)</b>											
	PK 37	PK 55	PK 75	PK11	PK15	P2K2	P3K0	P4K0	P5K5	P7K5	
FC 301/FC 302	0.37	0.55	0.75	1.1	1.5	2.2	3	4	5.5	7.5	
Typical Shaft Output [kW]	A2	A2	A2	A2	A2	A2	A2	A2	A2	A3	
Enclosure IP20/IP21	A1	A1	A1	A1	A1						
Enclosure IP20 (FC 301 only)	A5	A5	A5	A5	A5	A5	A5	A5	A5	A5	
Enclosure IP55											
<b>Output current</b>											
<b>High overload 160% for 1 minute</b>											
Shaft output [kW]	0.37	0.55	0.75	1.1	1.5	2.2	3	4	5.5	7.5	
Continuous (3 x 380-440 V) [A]	1.3	1.8	2.4	3	4.1	5.6	7.2	10	13	16	
Intermittent (3 x 380-440 V) [A]	2.1	2.9	3.8	4.8	6.6	9.0	11.5	16	20.8	25.6	
Continuous (3 x 440-500 V) [A]	1.2	1.6	2.1	2.7	3.4	4.8	6.3	8.2	11	14.5	
Intermittent (3 x 440-500 V) [A]	1.9	2.6	3.4	4.3	5.4	7.7	10.1	13.1	17.6	23.2	
Continuous KVA (400 V AC) [KVA]	0.9	1.3	1.7	2.1	2.8	3.9	5.0	6.9	9.0	11.0	
Continuous KVA (460 V AC) [KVA]	0.9	1.3	1.7	2.4	2.7	3.8	5.0	6.5	8.8	11.6	
Max. cable size (line, motor, brake) [AWG] <sup>2)</sup> [mm <sup>2</sup> ]	24 - 10 AWG 0.00031-0.0062 in. [0.2-4 mm] <sup>2</sup>										
<b>Max. input current</b>											
Continuous (3 x 380-440 V) [A]	1.2	1.6	2.2	2.7	3.7	5.0	6.5	9.0	11.7	14.4	
Intermittent (3 x 380-440 V) [A]	1.9	2.6	3.5	4.3	5.9	8.0	10.4	14.4	18.7	23.0	
Continuous (3 x 440-500 V) [A]	1.0	1.4	1.9	2.7	3.1	4.3	5.7	7.4	9.9	13.0	
Intermittent (3 x 440-500 V) [A]	1.6	2.2	3.0	4.3	5.0	6.9	9.1	11.8	15.8	20.8	
Max. pre-fuses <sup>1)</sup> [A]	10	10	10	10	10	20	20	20	32	32	
Environment											
Estimated power loss at rated max. load [W] <sup>4)</sup>	35	42	46	58	62	88	116	124	187	255	
Weight, enclosure IP20	4.7	4.7	4.8	4.8	4.9	4.9	4.9	4.9	6.6	6.6	
Enclosure IP55	13.5	13.5	13.5	13.5	13.5	13.5	13.5	13.5	14.2	14.2	
Efficiency <sup>4)</sup>	0.93	0.95	0.96	0.96	0.97	0.97	0.97	0.97	0.97	0.97	
0.33-10 hp [0.37-7.5 kW] only available as 160% high overload.											

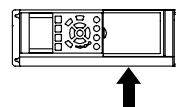
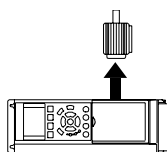



<b>Line Supply 3 x 380-500 VAC (FC 302), 3 x 380-480 VAC (FC 301)</b>												
FC 301/FC 302		P11K			P15K			P18K			P22K	
High/ Normal Load*	HO	NO	HO	NO	HO	NO	HO	NO	HO	NO	HO	NO
Typical Shaft output [kW]	11	15	15	18.5	18.5	22.0	18.5	22.0	22.0	22.0	22.0	30.0
Enclosure IP21	B1	B1	B1	B1	B1	B2	B2	B2	B2	B2	B2	B2
Enclosure IP55	B1	B1	B1	B1	B1	B2	B2	B2	B2	B2	B2	B2
<b>Output current</b>												
Continuous (3 x 380-440 V) [A]	24	32	32	37.5	37.5	44	44	44	44	44	44	61
Intermittent (60 sec over-load) (3 x 380-440 V) [A]	38.4	35.2	35.2	51.2	41.3	60	48.4	70.4	67.1	67.1	67.1	67.1
Continuous (3 x 440-500 V) [A]	21	27	27	34	34	40	40	40	40	40	40	52
Intermittent (60 sec over-load) (3 x 440-500 V) [A]	33.6	29.7	29.7	43.2	37.4	54.4	44	64	57.2	57.2	57.2	57.2
Continuous KVA (400 V AC) [KVA]	16.6	22.2	22.2	26	26	30.5	30.5	30.5	30.5	30.5	30.5	42.3
Continuous KVA (460 V AC) [KVA]		21.5	21.5	27.1	27.1	31.9	31.9	31.9	31.9	31.9	31.9	41.4
<b>Max. input current</b>												
Continuous (3 x 380-440 V) [A]	22	29	29	29	34	40	40	40	40	40	40	55
Intermittent (60 sec over-load) (3 x 380-440 V) [A]	35.2	31.9	31.9	46.4	37.4	54.4	44	64	60.5	60.5	60.5	60.5
Continuous (3 x 440-500 V) [A]	19	25	25	25	31	36	36	36	36	36	36	47
Intermittent (60 sec over-load) (3 x 440-500 V) [A]	30.4	27.5	27.5	40	34.1	49.6	39.6	57.6	51.7	51.7	51.7	51.7
Max. cable size [mm <sup>2</sup> / AWG] <sup>2)</sup>	16/6	16/6	16/6	16/6	16/6	35/2	35/2	35/2	35/2	35/2	35/2	35/2
Max. pre-fuses [A] <sup>1)</sup>	63	63	63	63	63	63	63	63	63	63	63	80
Estimated power loss at rated max. load [W] <sup>4)</sup>	291	392	392	379	465	444	525	547	547	547	547	739
Weight, enclosure IP21, IP 55 [kg]	23	23	23	23	23	27	27	27	27	27	27	27
Efficiency <sup>4)</sup>	0.977	0.977	0.977	0.978	0.978	0.979	0.979	0.979	0.979	0.979	0.979	0.978

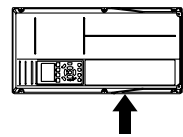
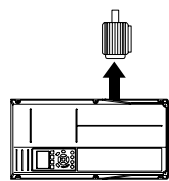

\* High overload = 160% torque during 60 s, Normal overload = 110% torque during 60 s

<b>Line Supply 3 x 380-500 VAC (FC 302), 3 x 380-480 VAC (FC 301)</b>												
FC 301/FC 302		P30K		P37K		P45K		P55K		P75K		
High/ Normal Load*	HO	NO	HO	NO	HO	NO	HO	NO	HO	NO	HO	NO
Typical Shaft output [kW]	30	37	37	45	45	55	55	75	75	75	90	90
Enclosure IP21	C1	C1	C1	C1	C1	C1	C2	C2	C2	C2	C2	C2
Enclosure IP55	C1	C1	C1	C1	C1	C1	C1	C1	C1	C1	C1	C1
<b>Output current</b>												
Continuous (3 x 380-440 V) [A]	61	73	73	90	90	106	106	147	147	147	177	177
Intermittent (60 sec overload) (3 x 380-440 V) [A]	91.5	80.3	110	135	135	117	159	162	221	221	195	195
Continuous (3 x 440-500 V) [A]	52	65	65	80	80	105	105	130	130	130	160	160
Intermittent (60 sec overload) (3 x 440-500 V) [A]	78	71.5	97.5	88	120	116	158	143	195	195	176	176
Continuous KVA (400 V AC) [KVA]	42.3	50.6	50.6	62.4	62.4	73.4	73.4	102	102	102	123	123
Continuous KVA (460 V AC) [KVA]	51.8	51.8	63.7	83.7	83.7	104	104	133	133	133	161	161
<b>Max. input current</b>												
Continuous (3 x 380-440 V) [A]	55	66	66	82	82	96	96	125	125	125	150	150
Intermittent (60 sec overload) (3 x 380-440 V) [A]	82.5	72.6	99	90.2	123	106	144	146	200	200	177	177
Continuous (3 x 440-500 V) [A]	47	59	59	73	73	95	95	118	118	118	145	145
Intermittent (60 sec overload) (3 x 440-500 V) [A]	70.5	64.9	88.5	80.3	110	105	143	130	177	177	160	160
Max. cable size [mm <sup>2</sup> / AWG] <sup>2)</sup>												
Max. pre-fuses [A] <sup>1)</sup>	100	100	125	160	160	250	250	250	250	250	250	250
Estimated power loss at rated max. load [W] <sup>4)</sup>	570	698	697	843	891	1083	1022	1384	1232	1232	1474	1474
Weight, enclosure IP21, IP 55 [kg]	45	45	45	45	45	45	65	65	65	65	65	65
Efficiency <sup>4)</sup>	0.983	0.983	0.983	0.982	0.982	0.983	0.983	0.983	0.983	0.983	0.985	0.985

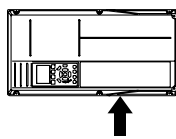
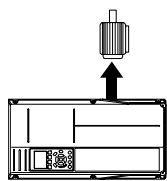

\* High overload = 160% torque during 60 s, Normal overload = 110% torque during 60 s



Line Supply 3 x 525 - 600 VAC (FC 302 only)										
FC 302	PK75	P1K1	P1K5	P2K2	P3K0	P3K7	P4K0	P5K5	P7K5	
Typical Shaft Output [kW]	0.75	1.1	1.5	2.2	3	3.7	4	5.5	7.5	
<b>Output current</b>										
Continuous (3 x 525-550 V) [A]	1.8	2.6	2.9	4.1	5.2	-	6.4	9.5	11.5	
Intermittent (3 x 525-550 V) [A]	2.9	4.2	4.6	6.6	8.3	-	10.2	15.2	18.4	
Continuous (3 x 525-600 V) [A]	1.7	2.4	2.7	3.9	4.9	-	6.1	9.0	11.0	
Intermittent (3 x 525-600 V) [A]	2.7	3.8	4.3	6.2	7.8	-	9.8	14.4	17.6	
Continuous kVA (525 V AC) [kVA]	1.7	2.5	2.8	3.9	5.0	-	6.1	9.0	11.0	
Continuous kVA (575 V AC) [kVA]	1.7	2.4	2.7	3.9	4.9	-	6.1	9.0	11.0	
Max. cable size (line, motor, brake) [AWG] <sup>2)</sup> [mm <sup>2</sup> ]	24 - 10 AWG 0.00031-0.0062 in. [0.2-4 mm] <sup>2</sup>					-	24 - 10 AWG 0.00031-0.0062 in. [0.2-4 mm] <sup>2</sup>			
<b>Max. input current</b>										
Continuous (3 x 525-600 V) [A]	1.7	2.4	2.7	4.1	5.2	-	5.8	8.6	10.4	
Intermittent (3 x 525-600 V) [A]	2.7	3.8	4.3	6.6	8.3	-	9.3	13.8	16.6	
Max. pre-fuses <sup>1)</sup> [A]	10	10	10	20	20	-	20	32	32	
<b>Environment</b>										
Estimated power loss at rated max. load [W] <sup>4)</sup>	35	50	65	92	122	-	145	195	261	
<b>Enclosure IP 20</b>										
Weight, enclosure IP20 [kg]	6.5	6.5	6.5	6.5	6.5	-	6.5	6.6	6.6	
Efficiency <sup>4)</sup>	0.97	0.97	0.97	0.97	0.97	-	0.97	0.97	0.97	

1) For type of fuse, see section *Fuses*.

2) American Wire Gauge.

3) Measured using 16.4 ft. [5 m] shielded motor cables at rated load and rated frequency.

4) The typical power loss is at nominal load conditions and expected to be within +/-15% (tolerance relates to variety in voltage and cable conditions).

Values are based on a typical motor efficiency (eff2/eff3 border line). Motors with lower efficiency will also add to the power loss in the adjustable frequency drive and opposite.

If the switching frequency is raised from nominal, the power losses may rise significantly.

LCP and typical control card power consumption values are included. Further options and customer load may add up to 30W to the losses. (Though typical, only 4 W extra for a fully loaded control card, or options for slot A or slot B, each.)

Although measurements are made with state of the art equipment, some measurement inaccuracy must be allowed for (+/-5%).

## ▣ General Specifications

### Line power supply (L1, L2, L3):

Supply voltage	200-240 V ±10%
Supply voltage	FC 301: 380-480 V / FC 302: 380-500 V ±10%
Supply voltage	FC 302: 525-600 V ±10%
Supply frequency	50/60 Hz
Max. imbalance temporary between line phases	3.0% of rated supply voltage
True Power Factor ( $\lambda$ )	≥ 0.9 nominal at rated load
Displacement Power Factor ( $\cos \phi$ ) near unity	(> 0.98)
Switching on input supply L1, L2, L3 (power-ups) ≤10 hp [7.5 kW]	maximum twice/min.
Switching on input supply L1, L2, L3 (power-ups) ≥ 15 hp [11 kW]	maximum once/min.
Environment according to EN60664-1	overvoltage category III/pollution degree 2

*The unit is suitable for use on a circuit capable of delivering no more than 100,000 RMS symmetrical Amperes, 240/500/600 V maximum.*

### Motor output (U, V, W):

Output voltage	0 - 100% of supply voltage
Output frequency	FC 301: 0.2 - 1000 Hz / FC 302: 0 - 1000 Hz
Switching on output	Unlimited
Ramp times	0.01 - 3600 sec.

### Torque characteristics:

Starting torque (Constant torque)	maximum 160% for 60 sec.*
Starting torque	maximum 180% up to 0.5 sec.*
Overload torque (Constant torque)	maximum 160% for 60 sec.*
Starting torque (Variable torque)	maximum 110% for 60 sec.*
Overload torque (Variable torque)	maximum 110% for 60 sec.

*\*Percentage relates to FC 300 nominal torque.*

### Cable lengths and cross-sections:

	FC 301: 164 ft. [50 m] / FC 301 (A1-encl.): 82 ft. [25 m] / FC 302: 150 m
Max. motor cable length, shielded/armored	
	FC 301: 246 ft. [75 m] / FC 301 (A1-encl.): 164 ft. [50 m] / FC 302: 300 m
Max. motor cable length, unshielded/unarmored	
Max. cross-section to motor, line power, load sharing and brake (see section Electrical Data in the FC 300 Design Guide MG.33.BX.YY for more information), (0.34-10 hp [0.25 kW - 7.5 kW])	0.0062 in. <sup>2</sup> [4 mm <sup>2</sup> ] / 10 AWG
Max. cross-section to motor, line power, load sharing and brake (see section Electrical Data in the FC 300 Design Guide MG.33.BX.YY for more information), (15-20 hp [11-15 kW])	0.025 in. <sup>2</sup> [16 mm <sup>2</sup> ] / 6 AWG
Max. cross-section to motor, line power, load sharing and brake (see section Electrical Data in the FC 300 Design Guide MG.33.BX.YY for more information), (25-30 hp [18-22 kW])	0.054 in. <sup>2</sup> [35 mm <sup>2</sup> ] / 2 AWG
Maximum cross-section to control terminals, flexible/rigid wire without cable end sleeves	0.0023 in. <sup>2</sup> [1.5 mm <sup>2</sup> ]/16 AWG



Maximum cross-section to control terminals, flexible wire with cable end sleeves	0.0016 in. <sup>2</sup> [1 mm <sup>2</sup> ]/18 AWG
Maximum cross-section to control terminals, flexible wire with cable end sleeves with collar	0.00078 in. <sup>2</sup> [0.5 mm <sup>2</sup> ]/20 AWG
Minimum cross-section to control terminals	0.0039 in. <sup>2</sup> [0.25 mm <sup>2</sup> ]/24 AWG

#### Protection and Features:

- Electronic thermal motor protection against overload.
- Temperature monitoring of the heatsink ensures that the adjustable frequency drive trips if the temperature reaches 203°F ± 9°F [95 °C ± 5°C]. An overload temperature cannot be reset until the temperature of the heatsink is below 158°C ± 9°C [70°C ± 5°C] (Guideline - these temperatures may vary for different power sizes, enclosures, etc.).
- The adjustable frequency drive is protected against short-circuits on motor terminals U, V, W.
- If a line phase is missing, the adjustable frequency drive trips or issues a warning (depending on the load).
- Monitoring of the intermediate circuit voltage ensures that the adjustable frequency drive trips if the intermediate circuit voltage is too low or too high.
- The adjustable frequency drive constantly checks for critical levels of internal temperature, load current, high voltage on the intermediate circuit and low motor speeds. As a response to a critical level, the adjustable frequency drive can adjust the switching frequency and/or change the switching pattern in order to ensure the performance of the drive.

#### Digital inputs:

Programmable digital inputs	FC 301: 4 (5) / FC 302: 4 (6)
Terminal number	18, 19, 27 <sup>1)</sup> , 29 <sup>4)</sup> , 32, 33,
Logic	PNP or NPN
Voltage level	0-24 V DC
Voltage level, logic '0' PNP	< 5 V DC
Voltage level, logic '1' PNP	> 10 V DC
Voltage level, logic '0' NPN <sup>2)</sup>	> 19 V DC
Voltage level, logic '1' NPN <sup>2)</sup>	< 14 V DC
Maximum voltage on input	28 V DC
Pulse frequency range	0-110 kHz
(Duty cycle) Min. pulse width	4.5 ms
Input resistance, R <sub>i</sub>	approximately 4 kΩ

#### Safe stop Terminal 37<sup>3)</sup> (Terminal 37 is fixed PNP logic):

Voltage level	0-24 V DC
Voltage level, logic '0' PNP	< 4 V DC
Voltage level, logic '1' PNP	> 20 V DC
Nominal input current at 24 V	50 mA rms
Nominal input current at 20 V	60 mA rms
Input capacitance	400 nF

*All digital inputs are galvanically isolated from the supply voltage (PELV) and other high-voltage terminals.*

- 1) Terminals 27 and 29 can also be programmed as output.
- 2) Except safe stop input Terminal 37.
- 3) Terminal 37 is only available in FC 302 and FC 301 A1 with Safe Stop. It can only be used as safe stop input. Terminal 37 is suitable for category 3 installations according to EN 954-1 (safe stop according to category 0 EN 60204-1), and as required by the EU Machinery Directive 98/37/EC. Terminal 37 and the Safe Stop function are designed in accordance with EN 60204-1, EN 50178, EN 61800-2, EN 61800-3 and EN 954-1. For correct and safe use of the Safe Stop function, follow the related information and instructions in the Design Guide.
- 4) FC 302 and FC 301/ A1 with safe stop only.

**Analog inputs:**

Number of analog inputs	2
Terminal number	53, 54
Modes	Voltage or current
Mode select	Switch S201 and switch S202
Voltage mode	Switch S201/switch S202 = OFF (U)
Voltage level	FC 301: 0 to + 10/ FC 302: -10 to +10 V (scalable)
Input resistance, $R_i$	approx. 10 k $\Omega$
Max. voltage	$\pm$ 20 V
Current mode	Switch S201/switch S202 = ON (I)
Current level	0/4 to 20 mA (scalable)
Input resistance, $R_i$	approx. 200 $\Omega$
Max. current	30 mA
Resolution for analog inputs	10 bit (+ sign)
Accuracy of analog inputs	Max. error 0.5% of full scale
Bandwidth	FC 301: 20 Hz/ FC 302: 100 Hz

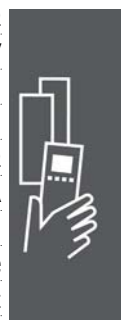

The analog inputs are galvanically isolated from the supply voltage (PELV) and other high-voltage terminals.

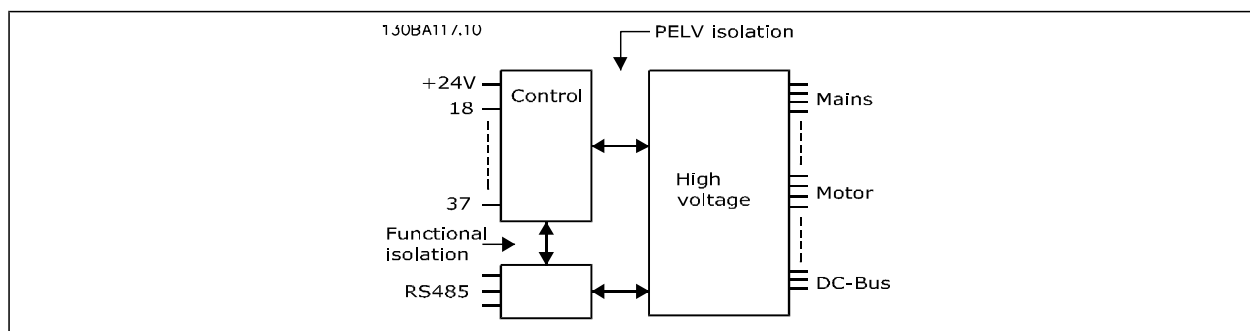

**Pulse/encoder inputs:**

Programmable pulse/encoder inputs	2/1
Terminal number pulse/encoder	29 <sup>3</sup> , 33 <sup>1</sup> ) / 32 <sup>2</sup> , 33 <sup>2</sup> ) <sup>3)</sup>
Max. frequency at terminal 29, 32, 33 <sup>3)</sup>	110 kHz (push-pull driven)
Max. frequency at terminal 29, 32, 33 <sup>3)</sup>	5 kHz (open collector)
Min. frequency at terminal 29, 32, 33 <sup>3)</sup>	4 Hz
Voltage level	see section on Digital input

Maximum voltage on input	28 V DC
Input resistance, $R_i$	approximately 4 k $\Omega$
Pulse input accuracy (0.1-1 kHz)	Max. error: 0.1% of full scale
Encoder input accuracy (1 - 110 kHz)	Max. error: 0.05 % of full scale

*The pulse and encoder inputs (terminals 29, 32, 33) are galvanically isolated from the supply voltage (PELV) and other high-voltage terminals.*

- 1) Pulse inputs are 29 and 33
- 2) Encoder inputs: 32 = A, and 33 = B
- 3) Terminal 29: Only FC 302

#### Analog output:

Number of programmable analog outputs	1
Terminal number	42
Current range at analog output	0/4 - 20 mA
Max. load GND - analog output	500 $\Omega$
Accuracy on analog output	Max. error: 0.5% of full scale
Resolution on analog output	12 bit

*The analog output is galvanically isolated from the supply voltage (PELV) and other high-voltage terminals.*

#### Control card, RS-485 serial communication:

Terminal number	68 (P,TX+, RX+), 69 (N,TX-, RX-)
Terminal number 61	Common for terminals 68 and 69

*The RS-485 serial communication circuit is functionally separated from other central circuits and galvanically isolated from the supply voltage (PELV).*

#### Digital output:

Programmable digital/pulse outputs	2
Terminal number	27, 29 <sup>1) 2)</sup>
Voltage level at digital/frequency output	0 - 24 V
Max. output current (sink or source)	40 mA
Max. load at frequency output	1 k $\Omega$
Max. capacitive load at frequency output	10 nF
Minimum output frequency at frequency output	0 Hz
Maximum output frequency at frequency output	32 kHz
Accuracy of frequency output	Max. error: 0.1% of full scale
Resolution of output frequency	12 bit

- 1) Terminal 27 and 29 can also be programmed as input.
- 2) Terminal 29: Only FC 302.

*The digital output is galvanically isolated from the supply voltage (PELV) and other high-voltage terminals.*

#### Control card, 24 V DC output:

Terminal number	12, 13
Output voltage	24 V +1, -3 V
Max. load	FC 301: 130 mA/ FC 302: 200 mA





The 24 V DC supply is galvanically isolated from the supply voltage (PELV), but has the same potential as the analog and digital inputs and outputs.

**Relay outputs:**

Programmable relay outputs	FC 301 ≤ 10 hp [7.5 kW]: 1 / FC 302 all hp [kW]: 2
Relay 01 Terminal number	1-3 (break), 1-2 (make)
Max. terminal load (AC-1) <sup>1)</sup> on 1-3 (NC), 1-2 (NO) (Resistive load)	240 V AC, 2 A
Max. terminal load (AC-15) <sup>1)</sup> (Inductive load @ cosφ 0.4)	240 V AC, 0.2 A
Max. terminal load (DC-1) <sup>1)</sup> on 1-2 (NO), 1-3 (NC) (Resistive load)	60 V DC, 1 A
Max. terminal load (DC-13) <sup>1)</sup> (Inductive load)	24 V DC, 0.1 A
Relay 02 (FC 302 only) Terminal number	4-6 (break), 4-5 (make)
Max. terminal load (AC-1) <sup>1)</sup> on 4-5 (NO) (Resistive load)	400 V AC, 2 A
Max. terminal load (AC-15) <sup>1)</sup> on 4-5 (NO) (Inductive load @ cosφ 0.4)	240 V AC, 0.2 A
Max. terminal load (DC-1) <sup>1)</sup> on 4-5 (NO) (Resistive load)	80 V DC, 2 A
Max. terminal load (DC-13) <sup>1)</sup> on 4-5 (NO) (Inductive load)	24 V DC, 0.1 A
Max. terminal load (AC-1) <sup>1)</sup> on 4-6 (NC) (Resistive load)	240 V AC, 2 A
Max. terminal load (AC-15) <sup>1)</sup> on 4-6 (NC) (Inductive load @ cosφ 0.4)	240 V AC, 0.2 A
Max. terminal load (DC-1) <sup>1)</sup> on 4-6 (NC) (Resistive load)	50 V DC, 2 A
Max. terminal load (DC-13) <sup>1)</sup> on 4-6 (NC) (Inductive load)	24 V DC, 0.1 A
Min. terminal load on 1-3 (NC), 1-2 (NO), 4-6 (NC), 4-5 (NO)	24 V DC 10 mA, 24 V AC 20 mA
Environment according to EN 60664-1	overvoltage category III/pollution degree 2

1) IEC 60947 part 4 and 5

The relay contacts are galvanically isolated from the rest of the circuit by reinforced isolation (PELV).

**Control card, 10 V DC output:**

Terminal number	50
Output voltage	10.5 V ±0.5 V
Max. load	15 mA

The 10 V DC supply is galvanically isolated from the supply voltage (PELV) and other high-voltage terminals.

**Control characteristics:**

Resolution of output frequency at 0 - 1000 Hz	FC 301: +/- 0.013 Hz / FC 302: +/- 0.003 Hz
Repeat accuracy of <i>Precise start/stop</i> (terminals 18, 19)	FC 301: ≤± 1ms / FC 302: ≤± 0.1 msec
System response time (terminals 18, 19, 27, 29, 32, 33)	FC 301: ≤ 10 ms / FC 302: ≤ 2 ms
Speed control range (open-loop)	1:100 of synchronous speed
Speed control range (closed-loop)	1:1000 of synchronous speed
Speed accuracy (open-loop)	30 - 4000 rpm: error ±8 rpm
Speed accuracy (closed-loop), depending on resolution of feedback device	0 - 6000 rpm: error ±0.15 rpm

All control characteristics are based on a 4-pole asynchronous motor

**Control card performance:**

Scan interval	FC 301: 5 ms / FC 302: 1 ms
---------------	-----------------------------



**Surroundings:**

Enclosure $\leq$ 10 HP [7.5 kW]	IP 20, IP 55
Enclosure $\geq$ 14.75 HP [11 kW]	IP 21, IP 55
Enclosure kit available $\leq$ 10 HP [7.5 kW]	IP 21/TYPE 1/IP 4X top
Vibration test	0.035 oz [1.0 g] RMS
Max. relative humidity	5%-95% (IEC 60 721-3-3; Class 3K3 (non-condensing) during operation)
Aggressive environment (IEC 721-3-3), uncoated	class 3C2
Aggressive environment (IEC 721-3-3), coated	class 3C3
Test method according to IEC 60068-2-43 H2S (10 days)	Max. 122°F [50°C] (24-hour average maximum 113°F [45°C])
Ambient temperature	Max. 122°F [50°C] (24-hour average maximum 113°F [45°C])

*Derating for high ambient temperature, see section on special conditions*

Minimum ambient temperature during full-scale operation	32° F [0° C]
Minimum ambient temperature at reduced performance	14° F [-10° C]
Temperature during storage/transport	-193°-149-158° F [-25°-+65/70° C]
Maximum altitude above sea level	3,280 ft [1,000 m]

*Derating for high altitude, see section on special conditions.*

EMC standards, Emission	EN 61800-3, EN 61000-6-3/4, EN 55011 EN 61800-3, EN 61000-6-1/2,
EMC standards, Immunity	EN 61000-4-2, EN 61000-4-3, EN 61000-4-4, EN 61000-4-5, EN 61000-4-6

*See section on special conditions*

**Control card, USB serial communication:**

USB standard	1.1 (Full speed)
USB plug	USB type B "device" plug

*Connection to PC is carried out via a standard host/device USB cable.*

*The USB connection is galvanically isolated from the supply voltage (PELV) and other high-voltage terminals.*

*The USB ground connection is not galvanically isolated from protection ground. Only use an isolated laptop as a PC connection to the USB connector on the FC 300 drive.*

**□ Efficiency****Efficiency of FC 300 Series ( $\eta_{VLT}$ )**

The load on the adjustable frequency drive has little effect on its efficiency. In general, the efficiency is the same at the rated motor frequency  $f_{M,N}$ , even if the motor supplies 100% of the rated shaft torque, or only 75% in case of part loads.

This also means that the efficiency of the adjustable frequency drive does not change even if other U/f characteristics are chosen.

However, the U/f characteristics influence the efficiency of the motor.

The efficiency declines a little when the switching frequency is set to a value greater than 5 kHz. The efficiency will also be slightly reduced if the line voltage is 500 V, or if the motor cable is longer than 98.43 ft. [30 m].

**Efficiency of the motor ( $\eta_{MOTOR}$ )**

The efficiency of a motor connected to the adjustable frequency drive depends on magnetizing level. In general, the efficiency is just as good as with line operation. The efficiency of the motor depends on the type of motor.

In the range of 75-100% of the rated torque, the efficiency of the motor is practically constant, both when it is controlled by the adjustable frequency drive, and when it runs directly on line power.

In small motors, the influence from the U/f characteristic on efficiency is marginal. However, in motors from 15 hp [11 kW] and up, the advantages are significant.

In general, the switching frequency does not affect the efficiency of small motors. The efficiency of motors from 15 hp [11 kW] and up improve by 1-2%. This is because the sine shape of the motor current is almost perfect at high switching frequency.

**Efficiency of the system ( $\eta_{SYSTEM}$ )**

To calculate the system efficiency, the efficiency of FC 300 Series ( $\eta_{VLT}$ ) is multiplied by the efficiency of the motor ( $\eta_{MOTOR}$ ):

$$\eta_{SYSTEM} = \eta_{VLT} \times \eta_{MOTOR}$$

**Acoustic Noise**

The acoustic noise from the adjustable frequency drive comes from three sources:

1. DC intermediate circuit coils.
2. Integral fan.
3. RFI filter choke.

The typical values measured at a distance of 3.3 ft (1 m) from the unit:

FC 301/ FC 302	
PK25-P7K5: 200-240 V, 380-500 V, 525-600V	IP20/IP21/IP4Xtop/Type 1 (NEMA 1)
Reduced fan speed	51 dB(A)
Full fan speed	60 dB(A)



**Peak Voltage on Motor**

When a transistor in the inverter bridge switches, the voltage across the motor increases by a dV/dt ratio depending on:

- the motor cable (type, cross-section, length, shielded or unshielded)
- inductance

The natural induction causes an overshoot  $U_{PEAK}$  in the motor voltage before it stabilizes itself at a level depending on the voltage in the intermediate circuit. The rise time and the peak voltage  $U_{PEAK}$  affect the service life of the motor. If the peak voltage is too high, motors without phase coil insulation are especially affected. If the motor cable is short (by a few yards), the rise time and peak voltage are lower. If the motor cable is long (328 ft. [100 m]), the rise time and peak voltage increase.

In motors without phase insulation paper or other insulation reinforcement suitable for operation with voltage supply (such as an adjustable frequency drive), fit a du/dt filter or a sine-wave filter on the output of the FC 100.

## □ Special Conditions

### □ Purpose of derating

Derating must be taken into account when using the adjustable frequency drive at low air pressure (high elevations), at low speeds, with long motor cables, cables with a large cross-section or at high ambient temperature. The required action is described in this section.

### □ Derating for Ambient Temperature

The average temperature ( $T_{AMB,AVG}$ ) measured over 24 hours must be at least 9° F [5° C] lower than the maximum allowed ambient temperature ( $T_{AMB,MAX}$ ).

If the adjustable frequency drive is operated at high ambient temperatures, the continuous output current should be decreased.

The derating depends on the switching pattern, which can be set to 60 PWM or SFAVM in par. 14-00.

## A enclosures

### 60 PWM (Pulse Width Modulation)

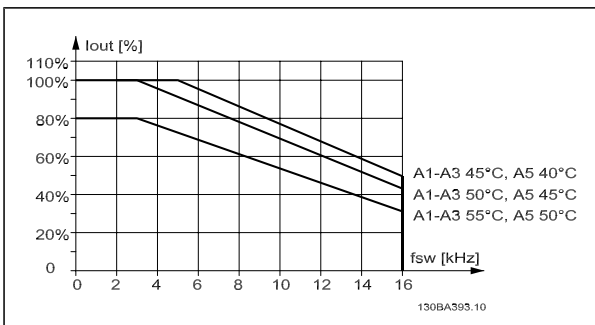

Derating of  $I_{out}$  for different  $T_{AMB,MAX}$  for enclosure A, using 60 PWM

### SFAVM - Stator Frequency Asynchron Vector Modulation

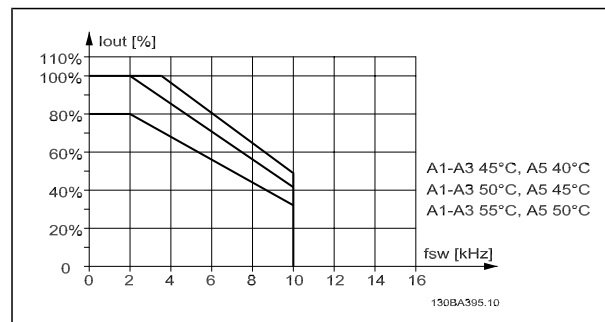

Derating of  $I_{out}$  for different  $T_{AMB,MAX}$  for enclosure A, using SFAVM

In enclosure A, the length of the motor cable has a relatively high impact on the recommended derating. Therefore, the recommended derating for an application with max. 32 ft. [10 m] motor cable is also shown.

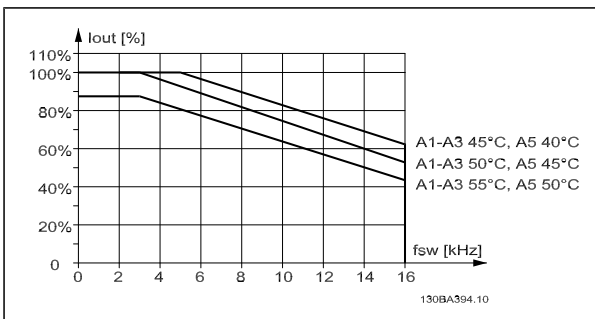

Derating of  $I_{out}$  for different  $T_{AMB,MAX}$  for enclosure A, using 60 PWM and a maximum of 32 ft. [10 m] motor cable

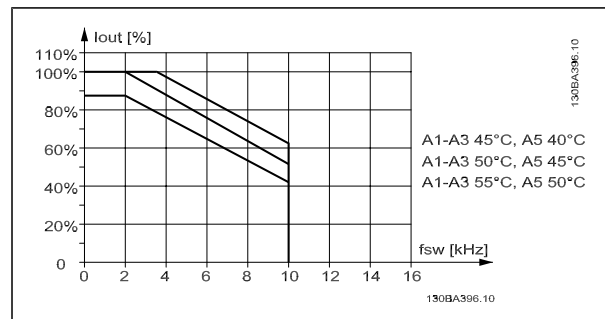

Derating of  $I_{out}$  for different  $T_{AMB,MAX}$  for enclosure A, using SFAVM and a maximum of 32 ft. [10 m] motor cable

**B enclosures**

For the B and C enclosures, the derating also depends on the overload mode selected in par. 1-04

**60 PWM (Pulse Width Modulation)**

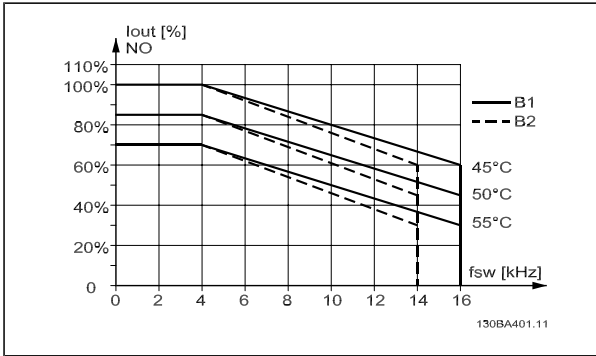

Derating of  $I_{out}$  for different  $T_{AMB, MAX}$  for enclosure B, using 60 PWM in normal torque mode (110% over-torque)

**SFAVM - Stator Frequency Asyncon Vector Modulation**

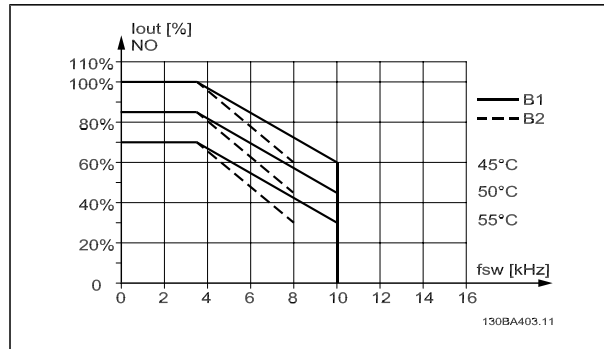

Derating of  $I_{out}$  for different  $T_{AMB, MAX}$  for enclosure B, using SFAVM in normal torque mode (110% over-torque)

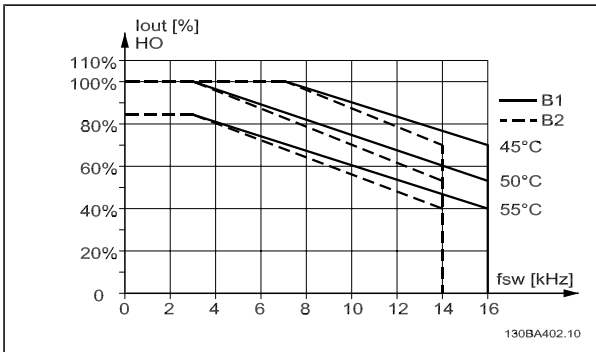

Derating of  $I_{out}$  for different  $T_{AMB, MAX}$  for enclosure B, using 60 PWM in high torque mode (160% over torque)

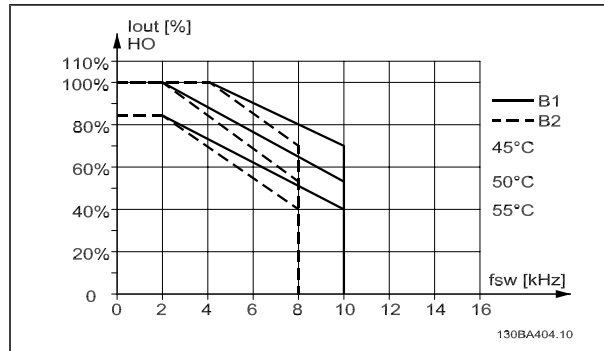

Derating of  $I_{out}$  for different  $T_{AMB, MAX}$  for enclosure B, using SFAVM in high torque mode (160% over torque)



**C enclosures**

**60 PWM (Pulse Width Modulation)**

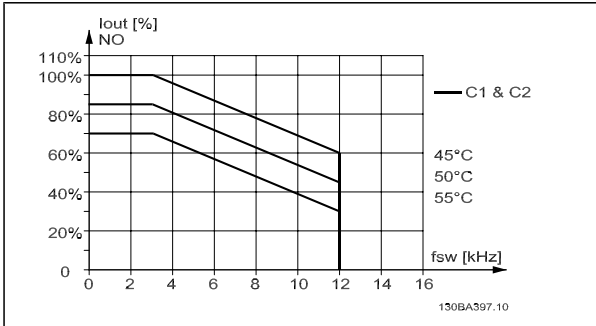

Derating of  $I_{out}$  for different  $T_{AMB, MAX}$  for enclosure C, using 60 PWM in normal torque mode (110% over-torque)

**SFAVM - Stator Frequency Asynchron Vector Modulation**

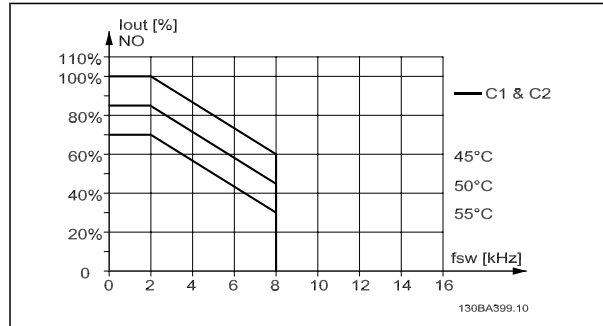

Derating of  $I_{out}$  for different  $T_{AMB, MAX}$  for enclosure C, using SFAVM in normal torque mode (110% over-torque)

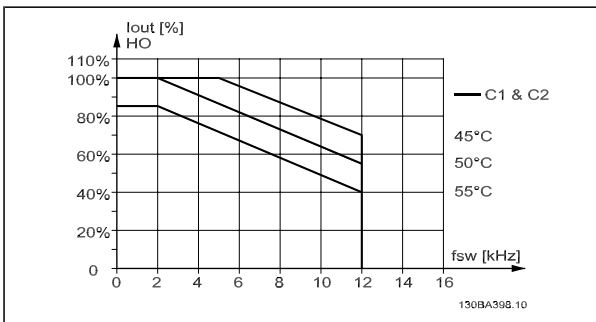

Derating of  $I_{out}$  for different  $T_{AMB, MAX}$  for enclosure C, using 60 PWM in high torque mode (160% over torque)

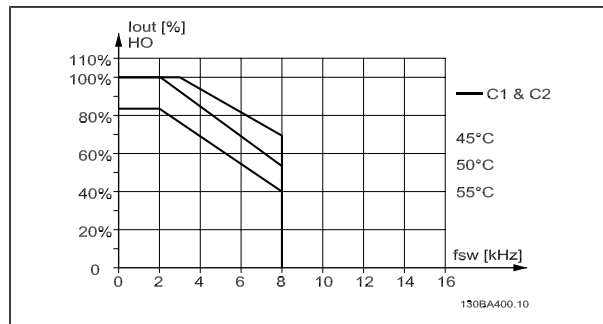

Derating of  $I_{out}$  for different  $T_{AMB, MAX}$  for enclosure C, using SFAVM in high torque mode (160% over torque)

**Derating for Low Air Pressure**

The cooling capability of air is decreased at a lower air pressure.

At an altitude lower than 3,280 ft [1,000 m], no derating is necessary; but at an altitude higher than 3,280 ft [1,000 m], the ambient temperature ( $T_{AMB}$ ) or max. output current ( $I_{out}$ ) should be derated in accordance with the diagram shown.

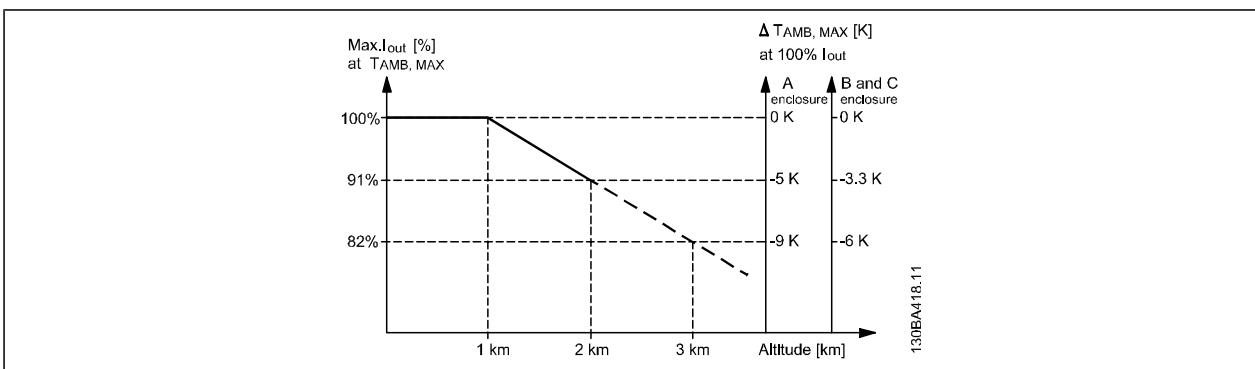

Derating of output current versus altitude at  $T_{AMB, MAX}$ . At altitudes higher than 6,600 feet [2 km], please contact Danfoss Drives regarding PELV.

An alternative is to lower the ambient temperature at high altitudes and thereby ensure 100% output current at high altitudes. As an example of how to read the graph, the situation at 6,600 ft [2 km] is elaborated. At a temperature of 113° F [45° C] ( $T_{AMB, MAX} - 3.3$  K), 91% of the rated output current is available. At a temperature of 107° F [41.7° C], 100% of the rated output current is available.

#### □ Derating for Running at Low Speed

When a motor is connected to an adjustable frequency drive, it is necessary to make sure that the cooling of the motor is adequate.

A problem may occur at low RPM values in constant torque applications. The motor fan may not be able to supply the required volume of air for cooling, which limits the torque that can be supported. Therefore, if the motor is to be run continuously at an RPM value lower than half of the rated value, the motor must be supplied with additional air-cooling (or a motor designed for this type of operation may be used).

An alternative is to reduce the load level of the motor by choosing a larger motor. However, the design of the adjustable frequency drive limits the motor size.

#### □ Derating for Installing Long Motor Cables or Cables with Larger Cross-Section

The maximum cable length for the FC 301 is 246 ft [75 m] when unshielded, and 164 ft [50 m] when shielded. For the FC 302, it is 984 ft [300 m] unshielded and 492 ft [150 m] shielded

The adjustable frequency drive has been designed to work using a motor cable with a rated cross-section. If a cable with a larger cross-section is used, reduce the output current by 5% for every step the cross-section is increased.

(Increased cable cross-section leads to increased capacity to ground, and thus an increased ground leakage current).

#### □ Automatic adaptations to ensure performance

The adjustable frequency drive constantly checks for critical levels of internal temperature, load current, high voltage on the intermediate circuit and low motor speeds. As a response to a critical level, the adjustable frequency drive can adjust the switching frequency and/or change the switching pattern in order to ensure the performance of the drive.







## How to Order

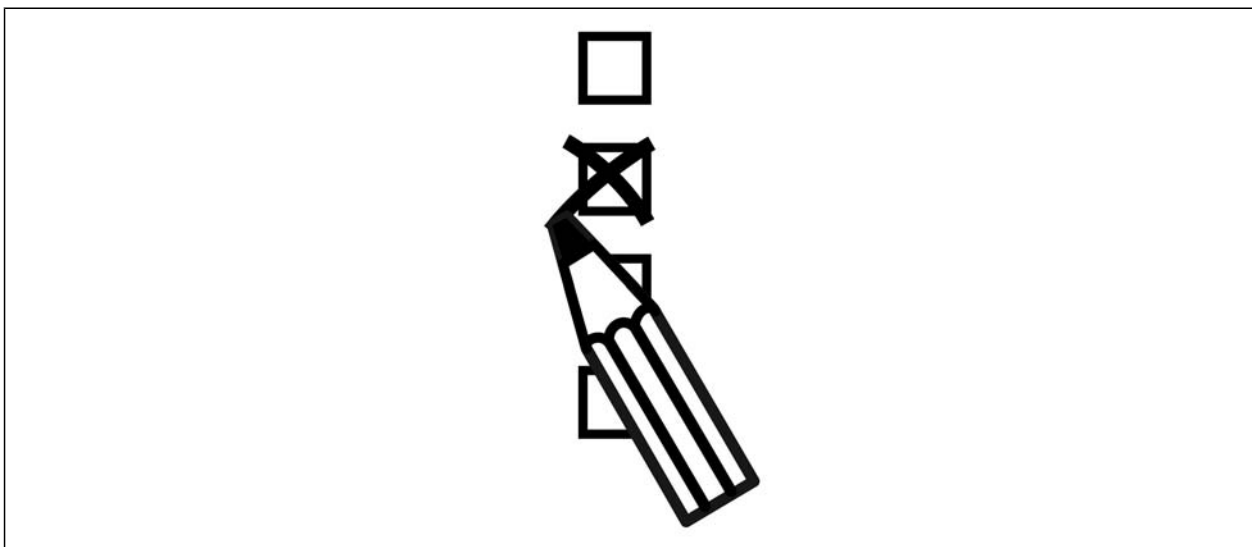

### □ Drive Configurator

It is possible to design an FC 300 adjustable frequency drive according to the application requirements by using the ordering number system.

For the FC 300 Series, you can order standard drives and drives with integral options by sending a type code string describing the product to the local Danfoss sales office, i.e.:

FC-302PK75T5E20H1BGCXXXSXXXXA0BXCXXXX0

The meaning of the characters in the string can be located in the pages containing the ordering numbers in the chapter *How to Select Your VLT*. In the example above, a Profibus DP V1 and a 24 V backup option is included in the drive.

Ordering numbers for FC 300 standard variants can also be located in the chapter *How to Select Your VLT*.

Use the Internet-based drive configurator to configure the right drive for the right application and generate the type code string. The drive configurator will automatically generate an eight-digit sales number to be delivered to your local sales office.

Furthermore, you can establish a project list with several products and send it to a Danfoss sales representative.

The drive configurator can be found on the global Internet site: The drive configurator can be found on the global Internet site:

### □ Ordering Form Type Code

1	2	3	4	5	6	7	8	9	10	11	12	13	14	15	16	17	18	19	20	21	22	23	24	25	26	27	28	29	30	31	32	33	34	35	36	37	38	39		
FC-	0	P				T				H					X	X	S	X	X	X	X	A		B		C														
																																					130BA052.14			



— How to Order —

Product groups	1-3
VLT series	4-6
Power rating	8-10
Phases	11
AC Line Voltage	12
Enclosure	14-15
<b>Enclosure type</b>	
<b>Enclosure class</b>	
<b>Control supply voltage</b>	
<b>Hardware configuration</b>	
RFI filter	16-17
Brake	18
Display (LCP)	19
Coating PCB	20
Line option	21
Adaptation A	22
Adaptation B	23
Software release	24-27
Software language	28
A options	29-30
B options	31-32
C0 options, MCO	33-34
<b>C1 options</b>	<b>35</b>
<b>C option software</b>	<b>36-37</b>
D options	38-39

Description	Pos	Possible choice
Product group	1-3	FC 30x
Drive series	4-6	FC 301 FC 302
Power rating	8-10	0.33-10 hp [0.25-7.5 kW]
Phases	11	Three phases (T)
AC line voltage	11-12	T 2: 200-240 V AC T 4: 380-480 V AC T 5: 380-500 V AC T 6: 525-600 V AC
Enclosure	14-15	E20: IP20 E21: IP 21/NEMA Type 1 E55: IP 55/NEMA Type 12 Z20: IP 20 <sup>1)</sup> Z21: IP 21 <sup>1)</sup> E66: IP 66
RFI filter	16-17	H1: RFI filter class A1/B1 H2: No RFI filter, observes class A2 H3: RFI filter class A1/B1 <sup>1)</sup> HX: No filter (600 V only)
Brake	18	B: Brake chopper included X: No brake chopper included T: Safe Stop No brake <sup>1)</sup> U: Safe stop brake chop- per <sup>1)</sup>
Display	19	G: Graphical Local Control Panel (LCP) N: Numerical Local Control Panel (LCP) X: No Local Control Panel
Coating PCB	20	C: Coated PCB X: No coated PCB
Line option	21	X: No AC line option 1: Line power disconnect D: Load sharing <sup>2)</sup> 8: Line power disconnect and load Sharing <sup>2)</sup>
Adaptation	22	Reserved
Adaptation	23	Reserved
Software release	24-27	Current software
Software language	28	
A options	29-30	A0: MCA 101 Profibus DP V1 A4: MCA 104 DeviceNet A6: MCA 105 CANOpen AX: No serial communication bus
B options	31-32	BX: No option BK: MCB 101 General purpose I/O option BR: MCB 102 Encoder option BU: MCB 103 Resolver option BP: MCB 105 Relay option BZ: MCB 108 Safety PLC Interface
C0 options	33-34	CX: No option C4: MCO 305, Programmable Motion Controller.
C1 options	35	
C option software	36-37	
D options	38-39	DX: No option D0: DC backup D0: MCB 107 Ext. 24 V backup

1): FC 301/ A1 enclosure only  
2): Power sizes ≥ 15 hp [11 kW] only

Not all choices/options are available for each FC 301/FC 302 variant. To verify if the appropriate version is available, please consult the Drive Configurator on the Internet.



□ **Ordering Numbers: Options and Accessories**

Type	Description	Ordering no.	
<b>Miscellaneous hardware</b>			
DC link connector	Terminal block for DC link connection on frame size A2/A3	130B1064	
IP 21/4X top/TYP E 1 kit	Enclosure, frame size A1: IP 21/IP 4X Top/TYP E 1	130B	
IP 21/4X top/TYP E 1 kit	Enclosure, frame size A2: IP 21/IP 4X Top/TYP E 1	130B1122	
IP 21/4X top/TYP E 1 kit	Enclosure, frame size A3: IP 21/IP 4X Top/TYP E 1	130B1123	
Profibus D-Sub 9	D-Sub connector kit for IP20, frame sizes A1, A2 and A3	130B1112	
Profibus shield plate	Profibus shield plate kit for IP20, frame sizes A1, A2 and A3	130B0524	
Terminal blocks	Screw terminal blocks for replacing spring loaded terminals 1 x 10-pin, 1 x 6-pin and 1 x 3-pin connectors	130B1116	
Footmount frame for flat pack resistors, frame size A2		175U0085	
Footmount frame for flat pack resistors, frame size A3		175U0088	
Footmount frame for 2 flat pack resistors, frame size A2		175U0087	
Footmount frame for 2 flat pack resistors, frame size A3		175U0086	
<b>LCP</b>			
LCP 101	Numerical Local Control Panel (NLCP)	130B1124	
LCP 102	Graphical Local Control Panel (GLCP)	130B1107	
LCP cable	Separate LCP cable, 9.8 ft. [3 m]	175Z0929	
LCP kit	Panel mounting kit including graphical LCP, fasteners, 9.8 ft. [3 m] cable and gasket	130B1113	
LCP kit	Panel mounting kit including numerical LCP, fasteners and gasket	130B1114	
LCP kit	Panel mounting kit for all LCPs including fasteners, 9.8 ft. [3 m] cable and gasket	130B1117	
<b>Options for Slot A</b>		<b>Uncoated</b>	<b>Coated</b>
MCA 101	Profibus option DP V0/V1	130B1100	130B1200
MCA 104	DeviceNet option	130B1102	130B1202
MCA 105	CANopen	130B1103	130B1205
<b>Options for Slot B</b>			
MCB 101	General purpose Input Output option	130B1125	130B1212
MCB 102	Encoder option	130B1115	130B1203
MCB 103	Resolver option	130B1127	130B1227
MCB 105	Relay option	130B1110	130B1210
MCB 108	Safety PLC interface (DC/DC drive)	130B1120	130B1220
<b>Options for Slot C</b>			
MCO 305	Programmable Motion Controller	130B1134	130B1234
Mounting kit for frame size A2 and A3		130B7530	-
Mounting kit for frame size A5		130B7532	-
Mounting kit for frame size B and C		130B7533	-
<b>Option for Slot D</b>			
MCB 107	24 V DC back-up	130B1108	130B1208
<b>External Options</b>			
Ethernet IP	Ethernet master	175N2584	-
<b>Spare Parts</b>			
Control board FC 302	Coated version	-	130B1109
Control board FC 301	Coated version	-	130B1126
Fan A2	Fan, frame size A2	130B1009	-
Fan A3	Fan, frame size A3	130B1010	-
Fan option C		130B7534	-
Backplate A5	Backplate A5 enclosures for	130B1098	
Connectors FC 300 Profibus	10 pieces Profibus connectors	130B1075	
Connectors FC 300 DeviceNet	10 pieces DeviceNet connectors	130B1074	
Connectors FC 302 10-pole	10 pieces 10-pole spring loaded connectors	130B1073	
Connectors FC 301 8-pole	10 pieces 8-pole spring loaded connectors	130B1072	
Connectors FC 300 5-pole	10 pieces 5-pole spring loaded connectors	130B1071	
Connectors FC 300 RS-485	10 pieces 3-pole spring loaded connectors for RS-485	130B1070	
Connectors FC 300 3-pole	10 pieces 3-pole connectors for relay 01	130B1069	
Connectors FC 302 3-pole	10 pieces 3-pole connectors for relay 02	130B1068	
Connectors FC 300 Line Power	10 pieces line connectors IP20/21	130B1067	
Connectors FC 300 Line Power	10 pieces line connectors IP 55	130B1066	
Connectors FC 300 Motor	10 pieces motor connectors	130B1065	
Connectors FC 300 Brake DC bus	10 pieces brake/load sharing connectors	130B1073	
Accessory bag A1	Accessory bag, frame size A1	130B1021	
Accessory bag A5	Accessory bag, frame size A5 (IP55)	130B1023	
Accessory bag A2	Accessory bag, frame size A2/A3	130B1022	
Accessory bag B1	Accessory bag, frame size B1	130B1024	
Accessory bag B2	Accessory bag, frame size B2	130B1025	
Accessory bag MCO 305		130B7535	

Options can be ordered as factory built-in options, see ordering information. For information on serial communication bus and application option compatibility with older software versions, please contact your Danfoss supplier.





Ordering Numbers: Brake Resistors AC line voltage 200-240 V																
FC 301/302																
Selected resistor																
Standard IP 20																
Aluminum-housed (flatpack) IP 65																
FC 301/ FC 302	P <sub>motor</sub> [kW]	R <sub>min</sub> [Ω]	R <sub>br, nom</sub> <sup>c</sup> [Ω]	Duty Cycle 10%			Duty Cycle 40%			R <sub>rec</sub> per item	Duty cycle	Max. torque load <sup>b</sup>				
				R <sub>rec</sub> [Ω]	P <sub>br max</sub> [kW]	P <sub>br max</sub> [kW]	R <sub>rec</sub> [Ω]	P <sub>br max</sub> [kW]	P <sub>br max</sub> [kW]			FC 301	FC 302			
Order no.	Order no.	Order no.	Order no.	Order no.	Order no.	Order no.	Order no.	Order no.	Order no.	Order no.	Order no.	Order no.	Order no.			
PK25	0.25	420	466.7	425	0.095	1841	175Uxxxx	425	0.430	1941	175Uxxxx	430Ω / 100W	8	1002	145%	160%
PK37	0.37	284	315.3	310	0.250	1842	175Uxxxx	310	0.800	1942	175Uxxxx	310Ω / 200W	16	0984	145%	160%
PK55	0.55	190	211.0	210	0.285	1843	175Uxxxx	210	1.350	1943	175Uxxxx	210Ω / 200W	9	0987	145%	160%
PK75	0.75	139	154.0	145	0.065	1820	175Uxxxx	145	0.260	1920	175Uxxxx	150Ω / 100W	14	1005	145%	160%
PK75	0.75	139	154.0	-	-	-	-	-	-	-	-	150Ω / 200W	40	0989	145%	160%
PIK1	1.1	90	104.4	90	0.095	1821	175Uxxxx	90	0.430	1921	175Uxxxx	100Ω / 100W	8	1006	145%	160%
PIK1	1.1	90	104.4	-	-	-	-	-	-	-	-	100Ω / 200W	20	0991	145%	160%
PIK5	1.5	65	75.7	65	0.250	1822	175Uxxxx	65	0.800	1922	175Uxxxx	72Ω / 200W	16	0992	145%	160%
P2K2	2.2	46	51.0	50	0.285	1823	175Uxxxx	50	1.00	1923	175Uxxxx	50Ω / 200W	9	0993	145%	160%
P3K0	3	33	37.0	35	0.430	1824	175Uxxxx	35	1.35	1924	175Uxxxx	35Ω / 200W	5.5	0994	145%	160%
P3K0	3	33	37.0	-	-	-	-	-	-	-	-	72Ω / 200W	12	2X0992 <sup>a</sup>	145%	160%
P3K7	3.7	25	29.6	25	0.800	1825	175Uxxxx	25	3.00	1925	175Uxxxx	60Ω / 200W	13	2X0996 <sup>a</sup>	145%	160%

<sup>a</sup> Order two pieces, as resistors must be connected in parallel.

<sup>b</sup> Max. load with the resistor in Danfoss standard program.

<sup>c</sup> R<sub>br, nom</sub> is the nominal (recommended) resistor value that ensures a braking energy on the motor shaft of 145%/160% for 1 minute.

Ordering Numbers: Brake Resistors AC line voltage 380-500 V / 380-480 V													
FC 301/302													
Selected resistor													
Aluminum-housed (flatpack) IP 65													
Standard IP 20													
Duty Cycle 10%													
Duty Cycle 40%													
Duty Cycle 100%													
FC 301/ FC 302	P <sub>motor</sub>	R <sub>min</sub>	R <sub>br, nom</sub> <sup>c</sup>	R <sub>rec</sub>	P <sub>br, max</sub>	Order no.	R <sub>rec</sub>	P <sub>br, max</sub>	Order no.	R <sub>rec</sub> per item	Duty cycle	Order no.	Max. torque load <sup>b</sup>
	[kW]	[Ω]	[Ω]	[Ω]	[kW]	175Uxxxx	[Ω]	[kW]	175Uxxxx	[Ω]	%	175Uxxxx	
PK37	0.37	620	1360.2	620	0.065	1840	830	0.450	1976	830Ω / 100W	20	1000	137%
PK55	0.55	620	915.0	620	0.065	1840	830	0.450	1976	830Ω / 100W	20	1000	137%
PK75	0.75	601	667.6	620	0.065	1840	620	0.260	1940	620Ω / 100W	14	1001	137%
PK75	0.75	601	667.6	-	-	-	-	-	-	620Ω / 200W	40	0982	137%
PIK1	1.1	408	452.8	425	0.095	1841	425	0.430	1941	430Ω / 100W	8	1002	137%
PIK1	1.1	408	452.8	-	-	-	-	-	-	430Ω / 200W	20	0983	137%
PIK5	1.5	297	330.4	310	0.250	1842	310	0.800	1942	310Ω / 200W	16	0984	137%
P2K2	2.2	200	222.6	210	0.285	1843	210	1.35	1943	210Ω / 200W	9	0987	137%
P3K0	3	145	161.4	150	0.430	1844	150	2.00	1944	150Ω / 200W	5.5	0989	137%
P3K0	3	145	161.4	-	-	-	-	-	-	300Ω / 200W	12	2X0985 <sup>a</sup>	137%
P4K0	4	108	119.6	110	0.600	1845	110	2.40	1945	240Ω / 200W	11	2X0986 <sup>a</sup>	137%
P5K5	5.5	77	86.0	80	0.850	1846	80	3.00	1946	160Ω / 200W	6.5	2X0988 <sup>a</sup>	137%
P7K5	7.5	56	62.4	65	1.0	1847	65	4.50	1947	130Ω / 200W	4	2X0990 <sup>a</sup>	137%
P11K	11	38	42.1	40	1.8	1848	40	5.00	1948	80Ω / 240W	9	2X0090 <sup>a</sup>	137%
P15K	15	27	30.5	30	2.8	1849	30	9.30	1949	72Ω / 240W	6	2X0091 <sup>a</sup>	137%
P18K	18.5	22	24.5	25	3.5	1850	25	12.70	1950				
P22K	22	18	20.3	20	4.0	1851	20	13.00	1951				

<sup>a</sup> Order two pieces, as resistors must be connected in parallel.

<sup>b</sup> Max. load with the resistor in Danfoss standard program.

<sup>c</sup> R<sub>br, nom</sub> is the nominal (recommended) resistor value that ensures a braking energy on the motor shaft of 137%/160% for 1 minute.



**Ordering Numbers: Harmonic Filters**

Harmonic filters are used to reduce line harmonics.

- AHF 010: 10% current distortion
- AHF 005: 5% current distortion

380-415 V, 50 Hz				
I <sub>AHF,N</sub>	Typical Motor Used [kW]	Danfoss ordering number		FC 301/FC 302
		AHF 005	AHF 010	
10 A	4, 5.5	175G6600	175G6622	P4K0, P5K5
19 A	7.5	175G6601	175G6623	P7K5
46 A	11	175G6602	175G6624	P11K
35 A	15, 18.5	175G6603	175G6625	P15K, P18K
43 A	22	175G6604	175G6626	P22K

440-480 V, 60 Hz				
I <sub>AHF,N</sub>	Typical Motor Used [HP]	Danfoss ordering number		FC 301/FC 302
		AHF 005	AHF 010	
19 A	10, 15	175G6612	175G6634	P7K5
26 A	20	175G6613	175G6635	P15K
35 A	25, 30	175G6614	175G6636	P18K, P22K

500 V, 50 Hz				
I <sub>AHF,N</sub>	Typical Motor Used [kW]	Danfoss ordering number		FC 301/FC 302
		AHF 005	AHF 010	
10 A	4, 5.5	175G6644	175G6656	P4K0, P5K5
19 A	7.5, 11	175G6645	175G6634	P7K5, P11K
26 A	15, 18.5	175G6646	175G6635	P15K, P18K
35 A	22	175G6647	175G6636	P22K

Matching the adjustable frequency drive and filter is pre-calculated based on 400 V/480 V and on a typical motor load (4-pole) and 160% torque.

**Ordering Numbers: Sine-wave Filter Modules, 200-240 VAC**

Line supply 3 x 200-240 V						
FC 301/FC 302	Rated current at 200 V	Max. torque at CT/VT	Max. output frequency	Power dissipation	Ordering no. IP00	Ordering no. IP20
PK25 - PK37	2.5 A	160%	120 Hz	60 W	130B2404	130B2439
PK55	4.5 A	160%	120 Hz	70 W	130B2406	130B2441
PK75 - P1K5	8 A	160%	120 Hz	80 W	130B2408	130B2443
P2K2 - P3K7	17 A	160%	120 Hz	125 W	130B2411	130B2446



**NOTE**

When using sine-wave filters, the switching frequency must be a minimum of 4.5 kHz (see par. 14-01).



□ **Ordering Numbers: Sine-wave Filter Modules, 380-500 VAC**

<b>Line supply 3 x 380-500 V</b>						
FC 301/FC 302	Rated current at 380 V	Max. torque at CT/VT	Max. output frequency	Power dissipation	Ordering no. IP00	Ordering no. IP20
PK37 - PK75	2.5 A	160%	120 Hz	60 W	130B2404	130B2439
PP1K1 - P1K5	4.5 A	160%	120 Hz	70 W	130B2406	130B2441
P2K2 - P3K0	8 A	160%	120 Hz	80 W	130B2408	130B2443
P4K0	10A	160%	120 Hz	95 W	130B2409	130B2444
P5K5 - P7K5	16 A	160%	120 Hz	125 W	130B2411	130B2446
<b>High overload torque</b>						
P11K	24 A	160%	60 Hz	150 W	130B2412	130B2447
P15K - P18K	38 A	160%	60 Hz	180 W	130B2413	130B2448
P22K	48 A	160%	60 Hz	270 W	130B2281	130B2307
<b>Normal overload torque</b>						
P11K - P15K	38 A	110%	60 Hz	180 W	130B2413	130B2448
P18K	48 A	110%	60 Hz	270 W	130B2281	130B2307
P22K	62 A	110%	60 Hz	310 W	130B2282	130B2308



**NOTE**

When using sine-wave filters, the switching frequency must be a minimum of 4.5 kHz (see par. 14-01).

□ **Ordering Numbers: Sine-wave Filter Modules, 525-690 VAC**

<b>Line supply 3 x 525-690 V</b>						
FC 301/FC 302	Rated current at 525 V	Max. torque at CT/VT	Max. output frequency	Power dissipation	Ordering no. IP00	Ordering no. IP20
PK75 - P7K5	13 A	160%	60 Hz	170 W	130B2321	130B2341



**NOTE**

When using sine-wave filters, the switching frequency must be a minimum of 4.5 kHz (see par. 14-01).





## How to Install

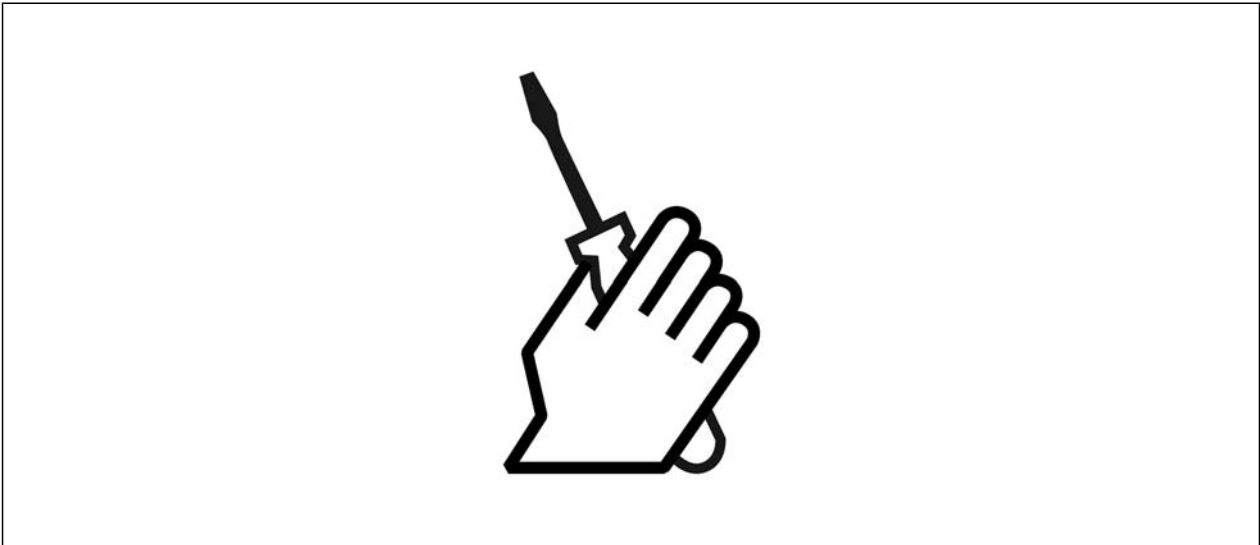

### ▣ Mechanical Dimension

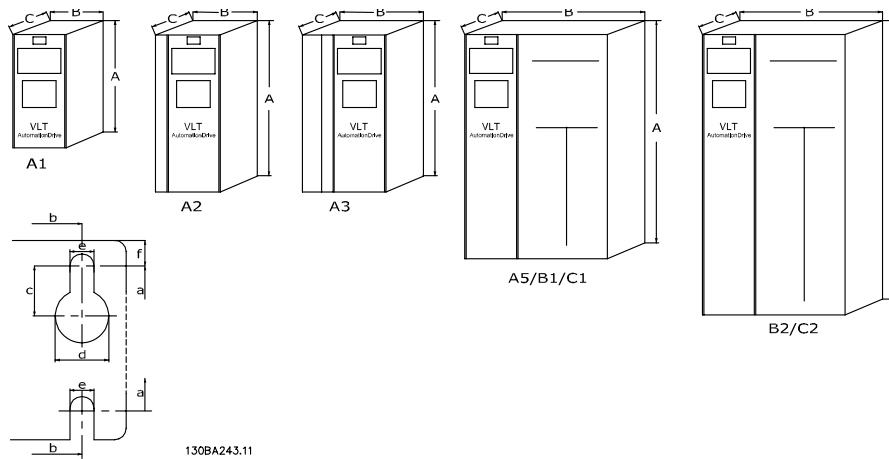

See the following table for enclosure dimensions.



Frame size		Mechanical dimensions													
A1		A2		A3		A5		B1		B2		C1		C2	
0.3-2 hp [0.25-1.5 kW] (200-240 V) 0.5-2 hp [0.37-1.5 kW] (380-480 V)		0.3-4 hp [0.25-3 kW] (200-240 V) 0.37-4.0 kW (380-480/500 V) 1-5 hp [0.75-4 kW] (525-600 V)		5 hp [3.7 kW] (200-240 V) 7.5-10 hp [5.5-7.5 kW] (380-480/500 V) 7.5-10 hp [5.5-7.5 kW] (525-600 V)		0.33-5 hp [0.25-3.7 kW] (200-240 V) 0.5-10 hp [0.37-7.5 kW] (380-480/500 V) 1-10 hp [0.75-7.5 kW] (525-600 V)		7.5-10 hp [5.5-7.5 kW] (200-240 V) 15-20 hp [11-15 kW] (380-480/500 V)		15 hp [11 kW] (200-240 V) 25-30 hp [18.5-22 kW] (380-480/500 V)		20-30 hp [15-22 kW] (200-240 V) 40-60 hp [30-45 kW] (380-480/500 V)		40-50 hp [30-37 kW] (200-240 V) 75-100 hp [55-75 kW] (380-480/500 V)	
TP	20	21	21	21	21	21	55/66	21/55/66	21/55/66	21/55/66	21/55/66	21/55/66	21/55/66		
NEMA	Chassis	Type 1	Chassis	Type 1	Chassis	Type 1	Type 12	Type 1/Type 12	Type 1/Type 12	Type 1/Type 12	Type 1/Type 12	Type 1/Type 12	Type 1/Type 12		
Height of backplate	7.87 in [200 mm]	10.6 in [268 mm]	14.7 in [374 mm]	10.6 in [268 mm]	14.8 in [375 mm]	10.6 in [268 mm]	16.54 in [420 mm]	18.9 in [480 mm]	25.6 in [650 mm]	26.8 in [680 mm]	25.6 in [650 mm]	30.3 in [770 mm]	30.3 in [770 mm]		
Height of backplate with de-coupling plate	12.4 in [316 mm]	14.7 in [374 mm]	14.7 in [374 mm]	14.7 in [374 mm]	14.7 in [374 mm]	14.7 in [374 mm]	-	-	-	-	-	-	-		
Distance between mounting holes	7.5 in [190 mm]	10.1 in [257 mm]	10.1 in [257 mm]	10.1 in [257 mm]	10.1 in [257 mm]	10.1 in [257 mm]	13.8 in [350 mm]	17.9 in [454 mm]	24.6 in [624 mm]	25.5 in [648 mm]	24.6 in [624 mm]	29.1 in [739 mm]	29.1 in [739 mm]		
Width															
Width of backplate	2.95 in [75 mm]	3.5 in [90 mm]	3.5 in [90 mm]	3.5 in [90 mm]	3.5 in [90 mm]	3.5 in [90 mm]	5.1 in [130 mm]	9.5 in [242 mm]	9.5 in [242 mm]	9.5 in [242 mm]	9.5 in [242 mm]	12.1 in [308 mm]	12.1 in [308 mm]		
Width of backplate with one C option															
Width of backplate with two C options															
Distance between mounting holes	2.4 in [60 mm]	2.8 in [70 mm]	2.8 in [70 mm]	2.8 in [70 mm]	2.8 in [70 mm]	2.8 in [70 mm]	4.3 in [110 mm]	8.3 in [210 mm]	8.3 in [210 mm]	8.3 in [210 mm]	8.3 in [210 mm]	10.7 in [272 mm]	10.7 in [272 mm]		
Depth															
Depth without option A/B	8.1 in [205 mm]	8.1 in [205 mm]	8.1 in [205 mm]	8.1 in [205 mm]	8.1 in [205 mm]	8.1 in [205 mm]	8.1 in [205 mm]	10.2 in [260 mm]	10.2 in [260 mm]	10.2 in [260 mm]	10.2 in [260 mm]	13.2 in [335 mm]	13.2 in [335 mm]		
With option A/B	8.7 in [220 mm]	8.7 in [220 mm]	8.7 in [220 mm]	8.7 in [220 mm]	8.7 in [220 mm]	8.7 in [220 mm]	8.7 in [220 mm]	10.2 in [260 mm]	10.2 in [260 mm]	10.2 in [260 mm]	10.2 in [260 mm]	13.2 in [335 mm]	13.2 in [335 mm]		
Without option A/B	8.14 in [207 mm]	8.14 in [207 mm]	8.14 in [207 mm]	8.14 in [207 mm]	8.14 in [207 mm]	8.14 in [207 mm]	8.14 in [207 mm]	-	-	-	-	-	-		
With option A/B	8.7 in [222 mm]	8.7 in [222 mm]	8.7 in [222 mm]	8.7 in [222 mm]	8.7 in [222 mm]	8.7 in [222 mm]	8.7 in [222 mm]	-	-	-	-	-	-		
Screw holes															
c	0.24 in [6.0 mm]	0.31 in [8.0 mm]	0.31 in [8.0 mm]	0.31 in [8.0 mm]	0.31 in [8.0 mm]	0.31 in [8.0 mm]	0.32 in [8.25 mm]	0.47 in [12 mm]	0.47 in [12 mm]	0.47 in [12 mm]	0.47 in [12 mm]	0.47 in [12 mm]	0.47 in [12 mm]		
d	ø0.35 in [8 mm]	ø0.43 in [11 mm]	ø0.43 in [11 mm]	ø0.43 in [11 mm]	ø0.43 in [11 mm]	ø0.43 in [11 mm]	ø0.47 in [12 mm]	ø0.75 in [19 mm]	ø0.75 in [19 mm]	ø0.75 in [19 mm]	ø0.75 in [19 mm]	ø0.75 in [19 mm]	ø0.75 in [19 mm]		
e	ø0.20 in [5 mm]	ø0.22 in [5.5 mm]	ø0.22 in [5.5 mm]	ø0.22 in [5.5 mm]	ø0.22 in [5.5 mm]	ø0.22 in [5.5 mm]	ø0.26 in [6.5 mm]	ø0.35 in [9 mm]	ø0.35 in [9 mm]	ø0.35 in [9 mm]	ø0.35 in [9 mm]	ø0.39 in [9.8 mm]	ø0.39 in [9.8 mm]		
f	0.19 in [5 mm]	0.35 in [9 mm]	0.35 in [9 mm]	0.35 in [9 mm]	0.35 in [9 mm]	0.35 in [9 mm]	0.35 in [9 mm]	0.35 in [9 mm]	0.35 in [9 mm]	0.35 in [9 mm]	0.35 in [9 mm]	0.69 in [17.6 mm]	0.71 in [18 mm]		
Max weight	5.95 lbs [2.7 kg]	10.8 lbs [4.9 kg]	11.68 lbs [5.3 kg]	14.55 lbs [6.6 kg]	15.43 lbs [7.0 kg]	15.43 lbs [7.0 kg]	29.76/31.3 lbs [13.5/14.2 kg]	50.7 lbs [23 kg]	59.5 lbs [27 kg]	59.5 lbs [27 kg]	59.5 lbs [27 kg]	94.8 lbs [43 kg]	134.48 lbs [61 kg]		

\* The front of the adjustable frequency drive is slightly convex. C is the shortest distance from back to front (measured from corner to corner) of the adjustable frequency drive. D is the longest distance from back to front (measured in the middle) of the adjustable frequency drive.

## □ Mechanical Installation

### □ Accessory Bag

Find the following parts included in the FC 100/300 Accessory Bag.

130BT309.11

Frame sizes A1, A2 and A3  
IP20/Chassis

130BT339.10

Frame size A5  
IP55/Type 12

130BT330.11

Frame sizes B1 and B2  
IP21/IP55/Type 1/Type 12

130BA406.10

Frame sizes C1 and C2  
IP55/66/Type 1/Type 12

1 + 2 only available in units with brake chopper. Only one relay connector is included for FC 101/301 units. For DC link connection (Load sharing), the connector 1 can be ordered separately (Code no 130B1064).

An eight-pole connector is included in the accessory bag for the FC 101/301 without Safe Stop.



### □ Mechanical mounting

FC 300 IP20 Frame sizes A1, A2 and A3, as well as IP21/ IP55 Frame sizes A5, B1, B2, C1 and C2 allow side-by-side installation.

If the IP 21 Enclosure kit (130B1122 or 130B1123) is used, there must be a min. clearance of 2 in. [50 mm] between the drives.

For optimal cooling conditions, allow a free air passage above and below the adjustable frequency drive. See table below.

Air passage for different enclosures		Enclosure:	A1	A2	A3	A5	B1	B2	C1	C2
	a (mm):		100	100	100	100	100	100	200	225
	b (mm):		100	100	100	100	100	100	200	225

1. Drill holes in accordance with the measurements given.
2. You must use screws that are suitable for the surface on which you want to mount the FC 300. Retighten all four screws.

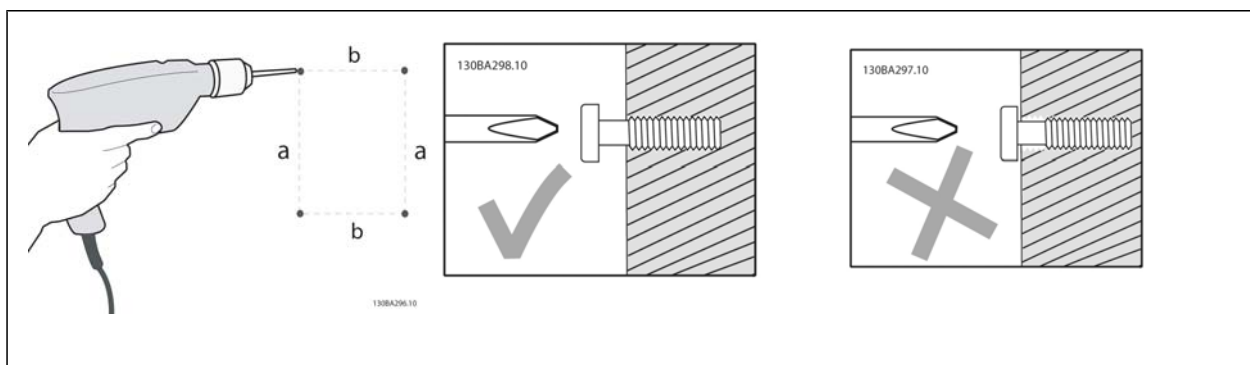

— How to Install —

Mounting frame sizes A1, A2 and A3:

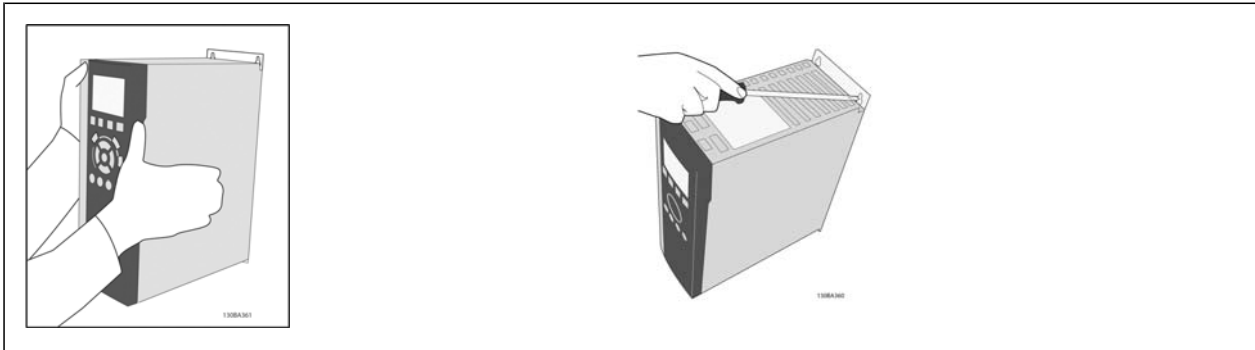

Mounting frame sizes A5, B1, B2, C1 and C2:

The back wall must always be solid for optimum cooling.

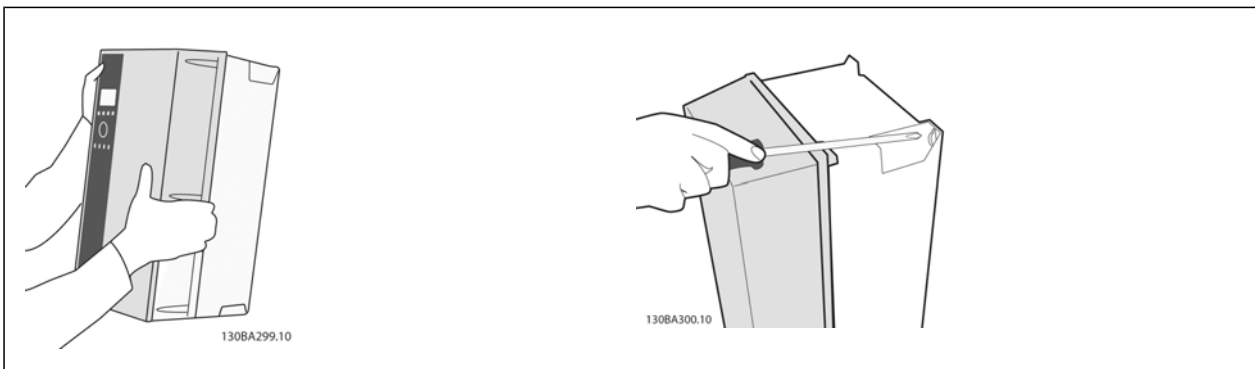

When mounting frame sizes A5, B1, B2, C1 and C2 on a non-solid back wall, the drive must be

provided with a back plate A due to insufficient cooling air over the heatsink.

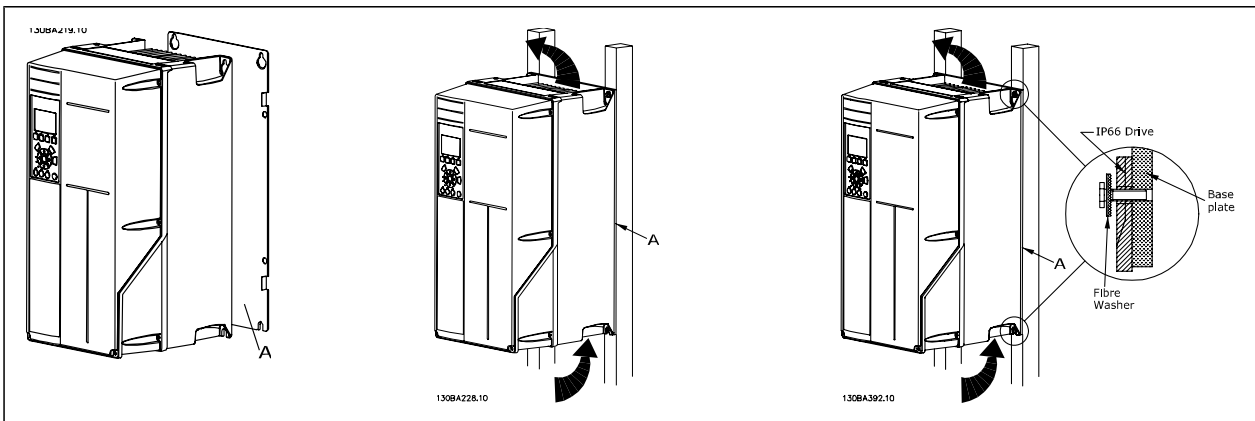

□ **Safety Requirements of Mechanical Installation**



Pay attention to the requirements that apply to integration and the field mounting kit. Follow the information in the list to avoid serious damage or injury, especially when installing large units.

The adjustable frequency drive is cooled by air circulation.



To protect the unit from overheating, it must be ensured that the ambient temperature *does not exceed the maximum temperature stated for the adjustable frequency drive*, and that the 24-hour average temperature *is not exceeded*. Locate the maximum temperature and 24-hour average in the paragraph entitled *Derating for Ambient Temperature*.

If the ambient temperature is in the range of 113°-131°F [45°C-55°C], derating of the adjustable frequency drive will become relevant; see *Derating for Ambient Temperature*.

The service life of the adjustable frequency drive is reduced if derating for ambient temperature is not taken into account.

#### □ **Field Mounting**

For field mounting the IP 21/IP 4X top/TYPE 1 kits or IP 54/55 units are recommended.





## □ Electrical Installation



### NOTE

#### Cables General

All cabling must comply with national and local regulations on cable cross-sections and ambient temperature. Copper (140°-167°F [60/75°C]) conductors are recommended.

#### Aluminum Conductors

Terminals can accept aluminum conductors, but the conductor surface must be clean, and the oxidation must be removed and sealed by neutral acid-free Vaseline grease before the conductor is connected. Furthermore, the terminal screw must be retightened after two days due to the softness of the aluminum. It is crucial to keep the connection a gas-tight joint, otherwise the aluminum surface will oxidize again.

Tightening-up Torque					
AFD size	200-240 V	380-500 V	525-600 V	Cable for:	Tightening torque
A1	0.33-2 hp [0.25-1.5 kW]	0.5-2 hp [0.37-1.5 kW]	-	Line, brake resistor, load sharing, motor cables	0.5-0.6 Nm
A2	0.33-3 hp [0.25-2.2 kW]	0.5-5 hp [0.37-4 kW]	1-5 hp [0.75-4 kW]		
A3	4-5 hp [3-3.7 kW]	7.5-10 hp [5.5-7.5 kW]	7.5-10 hp [5.5-7.5 kW]		
A5	4-5 hp [3-3.7 kW]	7.5-10 hp [5.5-7.5 kW]	1-10 hp [0.75-7.5 kW]		
B1	7.5-10 hp [5.5-7.5 kW]	15-20 hp [11-15 kW]	-	Line, brake resistor, load sharing, motor cables	1.8 Nm
B2	15 hp [11 kW]	25-30 hp [18.5-22 kW]	-	Relay	0.5-0.6 Nm
				Ground	2-3 Nm
				Line, brake resistor, load sharing cables	4.5 Nm
C1	20-30 hp [15-22 kW]	40-60 hp [30-45 kW]	-	Motor cables	4.5 Nm
				Relay	0.5-0.6 Nm
				Ground	2-3 Nm
C2	40-50 hp [30-37 kW]	75-100 hp [55-75 kW]	-	Line, brake resistor, load sharing cables	10 Nm
				Motor cables	14 Nm
				Relay	10 Nm
				Ground	0.5-0.6 Nm
					2-3 Nm

## □ Removal of Knockouts for Extra Cables

1. Remove the cable entry from the adjustable frequency drive (avoid foreign parts entering the adjustable frequency drive when removing knockouts).
2. The cable entry must be supported around the knockout you intend to remove.
3. The knockout can now be removed with a strong mandrel and a hammer.
4. Remove burrs from the hole.
5. Mount cable entry on adjustable frequency drive.



□ **Connection to Line Power and Grounding**



**NOTE**

The plug connector for power is pluggable on the FC 300 up to 10 hp [7.5 kW].

1. Insert the two screws into the de-coupling plate, and then slide it into place and tighten the screws.
2. Make sure the FC 300 is properly grounded. Connect to the ground connection (terminal 95). Use the screw from the accessory bag.
3. Place plug connector 91(L1), 92(L2), 93(L3) from the accessory bag onto the terminals labeled MAINS at the bottom of the FC 300.
4. Attach the line wires to the line power plug connector.
5. Support the cable with the enclosed supporting brackets.



**NOTE**

Make sure that the line voltage corresponds to the given line voltage on the FC 300 nameplate.

**IT Line**

Do not connect 400 V adjustable frequency drives with RFI filters to line supplies with a voltage between phase and ground of more than 440 V.



The ground connection cable cross-section must be at least 0.016 in.<sup>2</sup> [10 mm<sup>2</sup>] or 2 x rated line wires terminated separately according to EN 50178.

The line connection is fitted to the line switch if this is included.

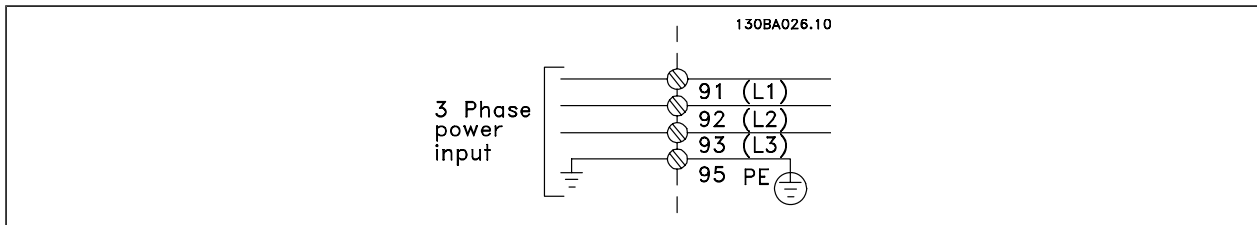

— How to Install —

Line power connection for frame sizes A1, A2 and A3:

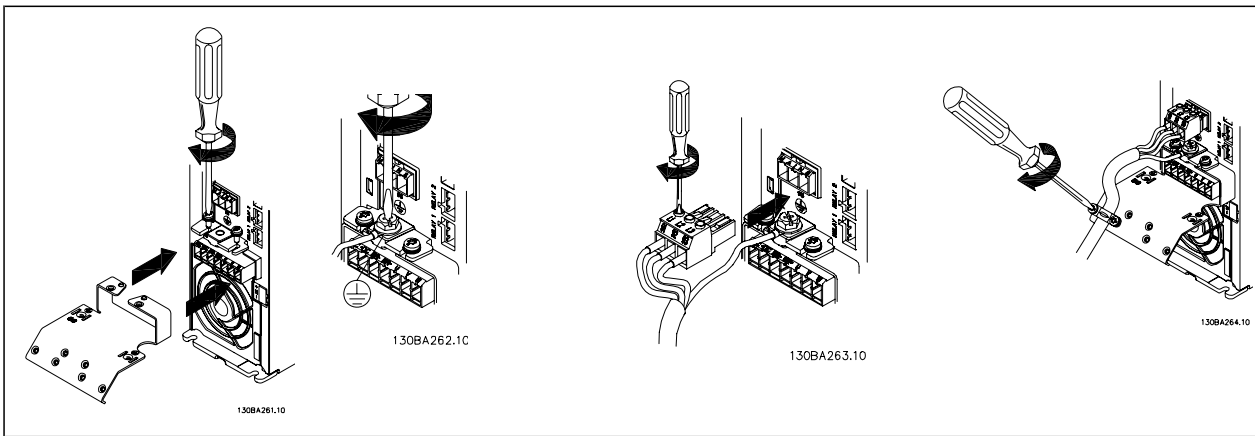

Line connector A5 (IP 55/66) Enclosure

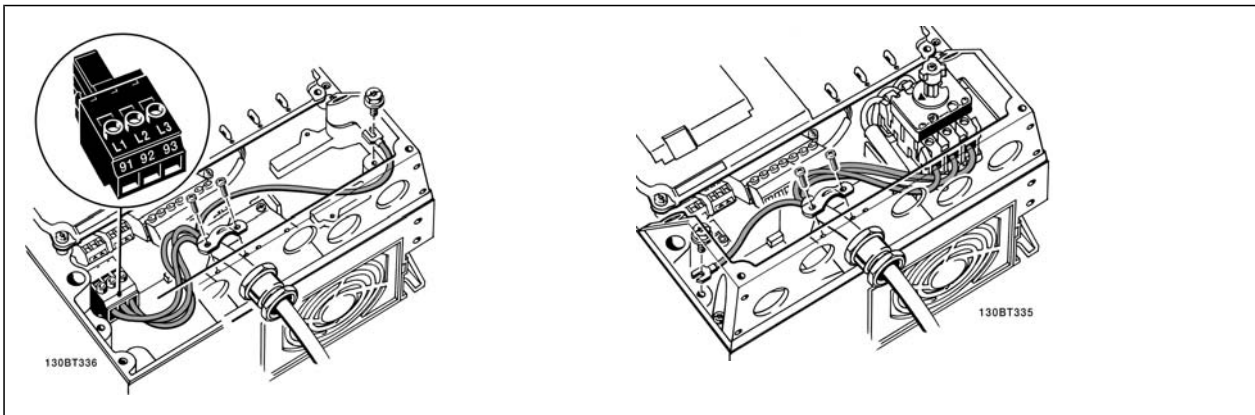

When the disconnecter is used (A5 enclosure), the PE must be mounted on the left side of the drive.

Line connection B1 and B2 (IP 21/NEMA Type 1 and IP 55/66/ NEMA Type 12) enclosures

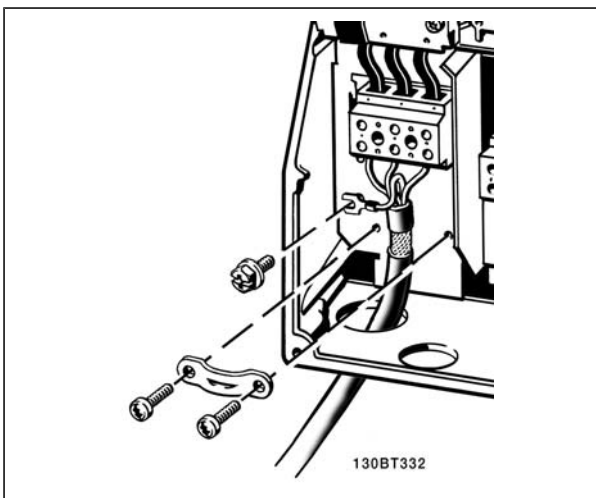

Line connection C1 and C2 (IP 21/ NEMA Type 1 and IP 55/66/ NEMA Type 12) enclosures

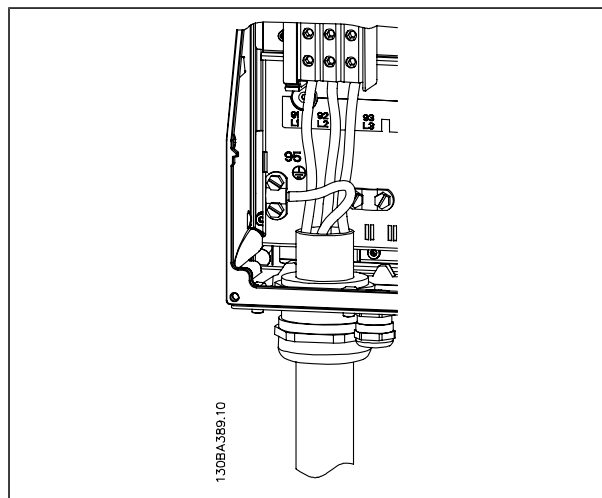

The power cables for line power are usually non-shielded cables.

#### □ Motor Connection



##### NOTE

Motor cable must be shielded/armored. The use of an unshielded/unarmored cable is against EMC requirements. Use a shielded/armored motor cable to comply with EMC emission specifications. For more information, see *EMC specifications* in the *VLT® AutomationDrive FC 300 Design Guide*.

See section General Specifications for correct dimensioning of motor cable cross-section and length.

**Shielding of cables:** Avoid installation with twisted shield ends (pigtailed). They spoil the shielding effect at higher frequencies. If it is necessary to break the shield to install a motor isolator or motor contactor, the shield must be continued at the lowest possible HF impedance.

Connect the motor cable shield to both the FC 300 decoupling plate and the motor's metal housing. Make the shield connections with the largest possible surface area (cable clamp). This is done by using the supplied installation devices in the FC 300.

If it is necessary to split the shield to install a motor isolator or motor relay, the shield must be continued with the lowest possible HF impedance.

**Cable length and cross-section:** The adjustable frequency drive has been tested with a given length of cable and a given cross-section of that cable. If the cross-section is increased, the cable capacitance - and thus the leakage current - may increase, thereby requiring that the cable length is reduced accordingly. Keep the motor cable as short as possible to reduce the noise level and leakage currents.

**Switching frequency:** When adjustable frequency drives are used together with sine-wave filters to reduce the acoustic noise from a motor, the switching frequency must be set according to the sine-wave filter instructions in Par. 14-01.

1. Fasten decoupling plate to the bottom of the FC 300 with screws and washers from the accessory bag.
2. Attach the motor cable to terminals 96 (U), 97 (V), 98 (W).
3. Connect to ground connection (terminal 99) on decoupling plate with screws from the accessory bag.
4. Insert plug connectors 96 (U), 97 (V), 98 (W) (up to 10 hp [7.5 kW]) and motor cable to terminals labeled MOTOR.
5. Fasten shielded cable to the decoupling plate with screws and washers from the accessory bag.



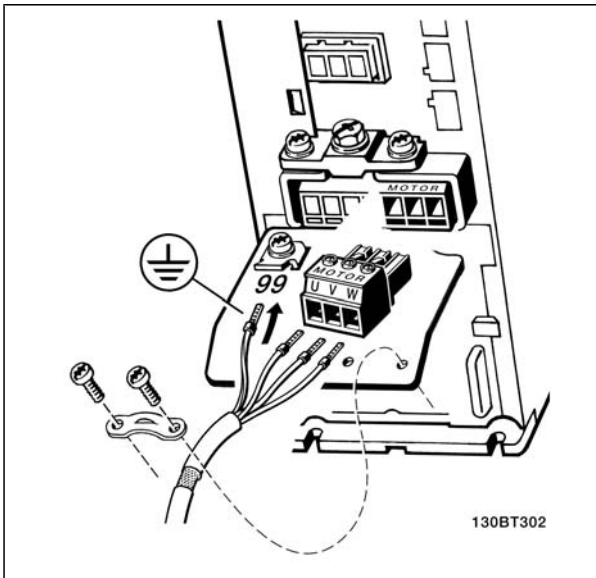

Motor connection for A1, A2 and A3

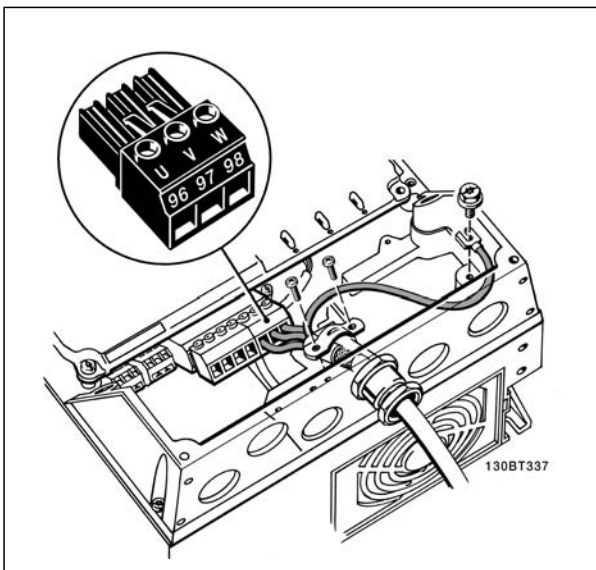

Motor connection for A5 (IP 55/66/NEMA Type 12) enclosure

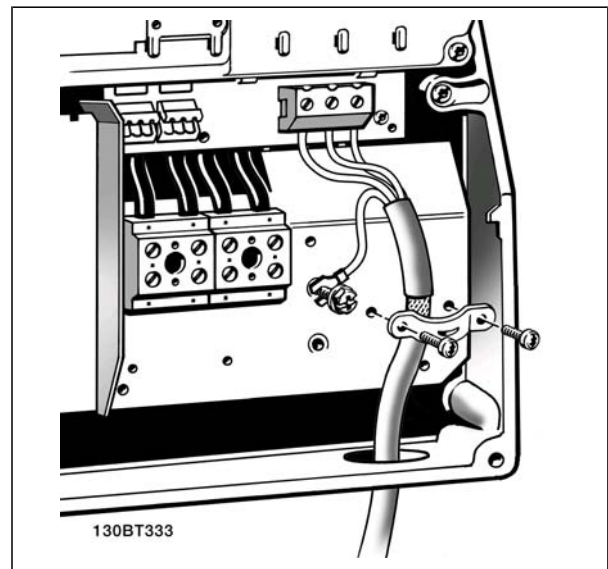

Motor connection for B1 and B2 (IP 21/ NEMA Type 1, IP 55/ NEMA Type 12 and IP66/ NEMA Type 4X) enclosure

All types of three-phase asynchronous standard motors can be connected to the FC 300. Normally, small motors are star-connected (230/400 V, Y). Large motors are normally delta-connected (400/690 V Δ). Refer to the motor name plate for the correct connection mode and voltage.



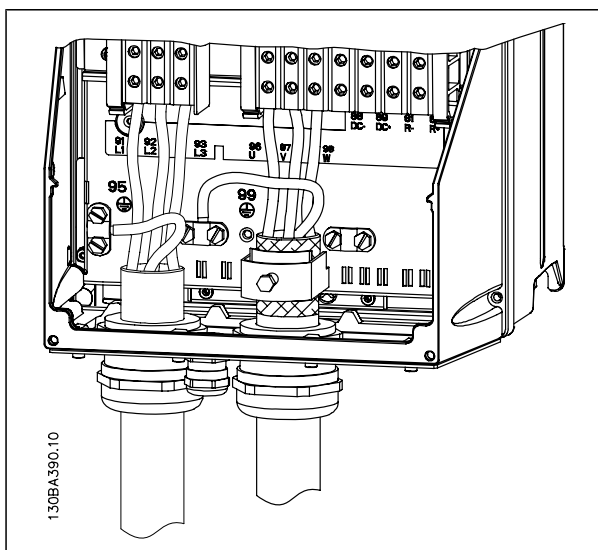

Motor connection C1 and C2 (IP 21/ NEMA Type 1 and IP 55/66/ NEMA Type 12) enclosure

Term. no.	96	97	98	99	
	U	V	W	PE <sup>1)</sup>	Motor voltage 0-100% of line voltage. 3 wires out of motor
	U1 W2	V1 U2	W1 V2	PE <sup>1)</sup>	Delta-connected 6 wires out of motor
	U1	V1	W1	PE <sup>1)</sup>	Star-connected U2, V2, W2 U2, V2 and W2 to be interconnected separately.

<sup>1)</sup>Protected Ground Connection

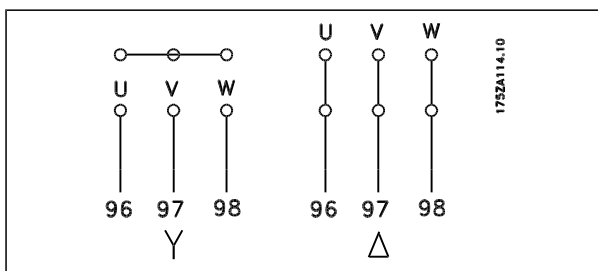

**NOTE**

In motors without phase insulation paper or other insulation reinforcement suitable for operation with voltage supply (such as an adjustable frequency drive), fit an sine-wave filter on the output of the FC 300.

**Fuses**

**Branch circuit protection:**

In order to protect the installation against electrical and fire hazards, all branch circuits in an installation, switch gear, machines, etc. must be short-circuited and overcurrent protected according to national/international regulations.

**Short-circuit protection:**

The adjustable frequency drive must be protected against short circuit in order to avoid electrical or fire hazard. Danfoss recommends using the fuses mentioned below to protect service personnel and equipment in case of an internal failure in the drive. The adjustable frequency drive provides full short-circuit protection in case of a short-circuit on the motor output.

**Overcurrent protection:**

Provide overload protection to avoid fire hazard due to overheating of the cables in the installation. The adjustable frequency drive is equipped with an internal overcurrent protection that can be used for upstream overload protection (UL applications excluded). See par. 4-18. Moreover, fuses or circuit breakers can be used to provide the overcurrent protection in the installation. Overcurrent protection must always be carried out according to national regulations.

Fuses must be designed for protection in a circuit capable of supplying a maximum of 100,000 A<sub>rms</sub> (symmetrical), 500 V maximum.

**Non-UL compliance**

If UL/cUL is not to be complied with, we recommend using the following fuses, which will ensure compliance with EN50178:

In case of malfunction, not following the recommendation may result in unnecessary damage to the adjustable frequency drive.

FC 300	Max. fuse size <sup>1)</sup>	Voltage	Type
K25-K75	10A	200-240 V	type gG
1K1-2K2	20A	200-240 V	type gG
3K0-3K7	32A	200-240 V	type gG
5K5-7K5	63A	380-500 V	type gG
11K	80A	380-500 V	type gG
15K-18K	125A	380-500 V	type gG
5			
22K	160A	380-500 V	type aR
30K	200A	380-500 V	type aR
37K	250A	380-500 V	type aR

FC 300	Max. fuse size <sup>1)</sup>	Voltage	Type
K37-1K5	10A	380-500 V	type gG
2K2-4K0	20A	380-500 V	type gG
5K5-7K5	32A	380-500 V	type gG
11K-18K	63A	380-500 V	type gG
22K	80A	380-500 V	type gG
30K	100A	380-500 V	type gG
37K	125A	380-500 V	type gG
45K	160A	380-500 V	type aR
55K-75K	250A	380-500 V	type aR

1) Max. fuses - see national/international regulations to select an appropriate fuse size.

**UL Compliance**
**200-240 V**

FC 300	Bussmann	Bussmann	Bussmann	SIBA	Littel fuse	Ferraz-Shawmut	Ferraz-Shawmut
kW	Type RK1	Type J	Type T	Type RK1	Type RK1	Type CC	Type RK1
K25-K75	KTN-R10	JKS-10	JJN-10	5017906-010	KLN-R10	ATM-R10	A2K-10R
1K1-2K2	KTN-R20	JKS-20	JJN-20	5017906-020	KLN-R20	ATM-R20	A2K-20R
3K0-3K7	KTN-R30	JKS-30	JJN-30	5012406-032	KLN-R30	ATM-R30	A2K-30R
5K5	KTN-R50	KS-50	JJN-50	5014006-050	KLN-R50		A2K-50R
7K5	KTN-R60	JKS-60	JJN-60	5014006-063	KLN-R60		A2K-60R
11K	KTN-R80	JKS-80	JJN-80	5014006-080	KLN-R80		A2K-80R
15K-18K5	KTN-R125	JKS-150	JJN-125	2028220-125	KLN-R125		A2K-125R
22K	FWX-150	---	---	2028220-150	L25S-150		A25X-150
30K	FWX-200	---	---	2028220-200	L25S-200		A25X-200
37K	FWX-250	---	---	2028220-250	L25S-250		A25X-250



**380-500 V, 525-600 V**

FC 300	Bussmann	Bussmann	Bussmann	SIBA	Littel fuse	Ferraz-Shawmut	Ferraz-Shawmut
kW	Type RK1	Type J	Type T	Type RK1	Type RK1	Type CC	Type RK1
K37-1K5	KTS-R10	JKS-10	JJS-10	5017906-010	KLS-R10	ATM-R10	A6K-10R
2K2-4K0	KTS-R20	JKS-20	JJS-20	5017906-020	KLS-R20	ATM-R20	A6K-20R
5K5-7K5	KTS-R30	JKS-30	JJS-30	5012406-032	KLS-R30	ATM-R30	A6K-30R
11K	KTS-R40	JKS-40	JJS-40	5014006-040	KLS-R40		A6K-40R
15K	KTS-R50	JKS-50	JJS-50	5014006-050	KLS-R50		A6K-50R
18K	KTS-R60	JKS-60	JJS-60	5014006-063	KLS-R60		A6K-60R
22K	KTS-R80	JKS-80	JJS-80	2028220-100	KLS-R80		A6K-80R
30K	KTS-R100	JKS-100	JJS-100	2028220-125	KLS-R100		A6K-100R
37K	KTS-R125	JKS-150	JJS-150	2028220-125	KLS-R125		A6K-125R
45K	KTS-R150	JKS-150	JJS-150	2028220-150	KLS-R150		A6K-150R
55K	FWH-220	-	-	2028220-200	L50S-225		A50-P225
75K	FWH-250	-	-	2028220-250	L50S-250		A50-P250

KTS fuses from Bussmann may substitute for KTN in 240 V adjustable frequency drives.

FWH fuses from Bussmann may substitute for FWX in 240 V adjustable frequency drives.

KLSR fuses from LITTEL FUSE may substitute for KLNR fuses in 240 V adjustable frequency drives.

L50S fuses from LITTEL FUSE may substitute for L50S fuses in 240 V adjustable frequency drives.

A6KR fuses from FERRAZ SHAWMUT may substitute for A2KR in 240 V adjustable frequency drives.

A50X fuses from FERRAZ SHAWMUT may substitute for A25X in 240 V adjustable frequency drives.





□ **Access to Control Terminals**

All terminals to the control cables are located underneath the terminal cover on the front of the adjustable frequency drive. Remove the terminal cover using a screwdriver (see illustration).

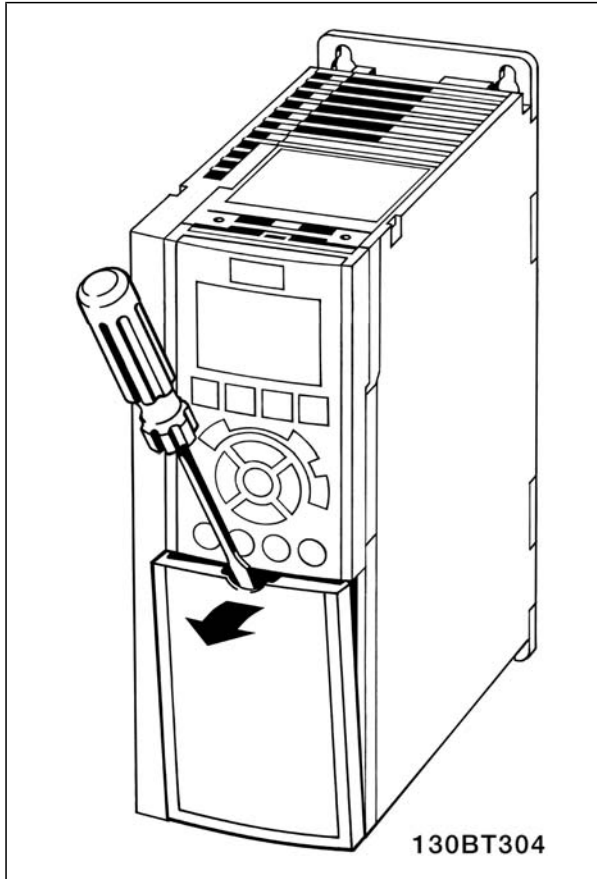

A1, A2 and A3 enclosures

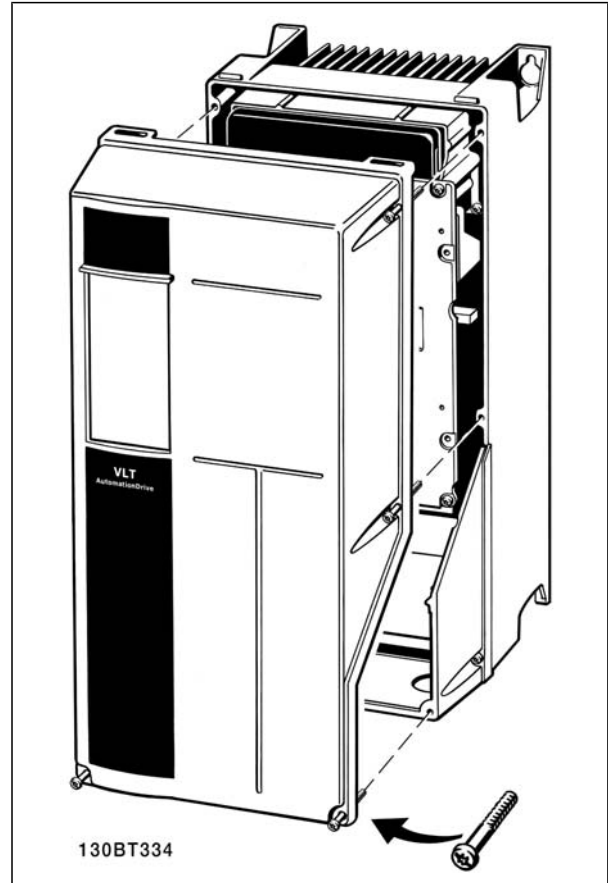

A5, B1, B2, C1 and C2 enclosures

□ **Control Terminals**

**Control Terminals, FC 301**

Drawing reference numbers:

1. 8-pole plug, digital I/O.
2. 3-pole plug, RS485 bus.
3. 6-pole, analog I/O.
4. USB Connection.

**Control Terminals, FC 302**

Drawing reference numbers:

1. 10-pole plug, digital I/O.
2. 3-pole plug, RS485 bus.
3. 6-pole, analog I/O.



4. USB Connection.

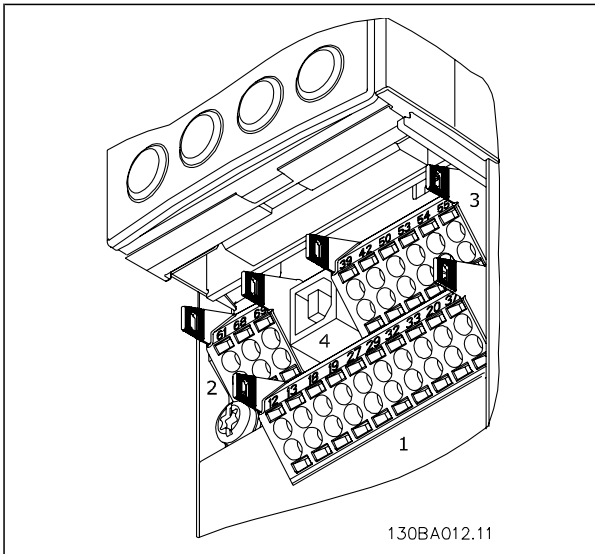

Control terminals (all enclosures)

□ **Electrical Installation, Control Terminals**

To mount the cable to the terminal:

1. Strip isolation of 0.34-0.39 in [9-10 mm]
2. Insert a screw driver<sup>1)</sup> in the square hole.
3. Insert the cable in the adjacent circular hole.
4. Remove the screwdriver. The cable is now mounted to the terminal.

To remove the cable from the terminal:

1. Insert a screw driver<sup>1)</sup> in the square hole.
2. Pull out the cable.

<sup>1)</sup> Max. 0.015 x 0.1 in. [0.4 x 2.5 mm]

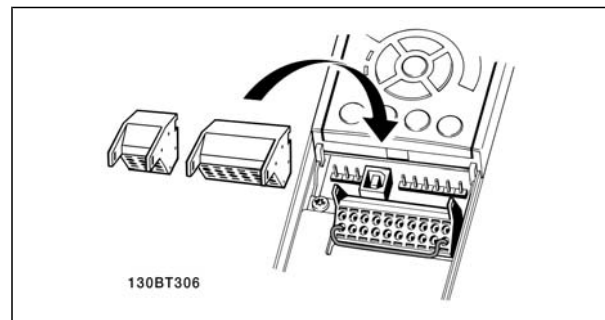
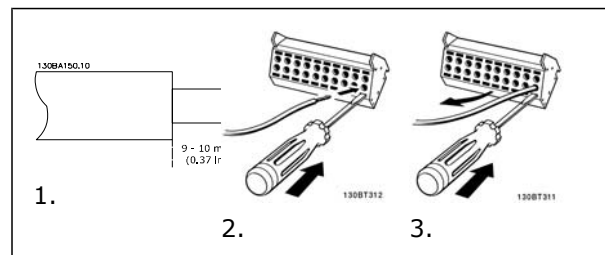

Assembling of IP55 / NEMA Type 12 (A5 housing) with line supply disconnecter

The line power switch is placed on the left side on the B1, B2, C1 and C2 enclosures. The line power switch on the A5 enclosure is placed on the right side



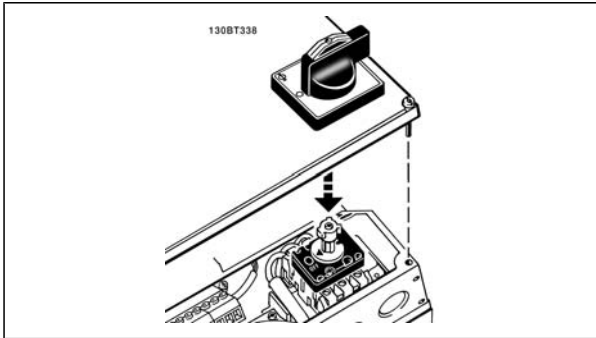

□ **Basic Wiring Example**

1. Mount terminals from the accessory bag to the front of the FC 300.
2. Connect terminals 18, 27 and 37 (FC 302 only) to +24 V (terminal 12/13)

Default settings:

18 = Start, Par 5-10 [9]

27 = Stop inverse, Par 5-12 [6]

37 = safe stop inverse

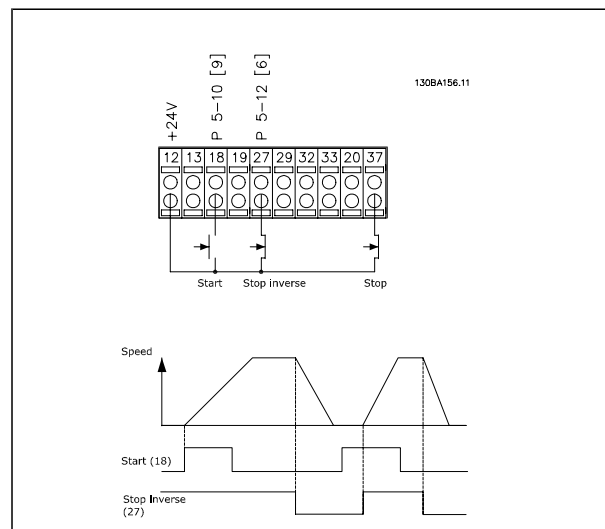

□ Electrical Installation, Control Cables

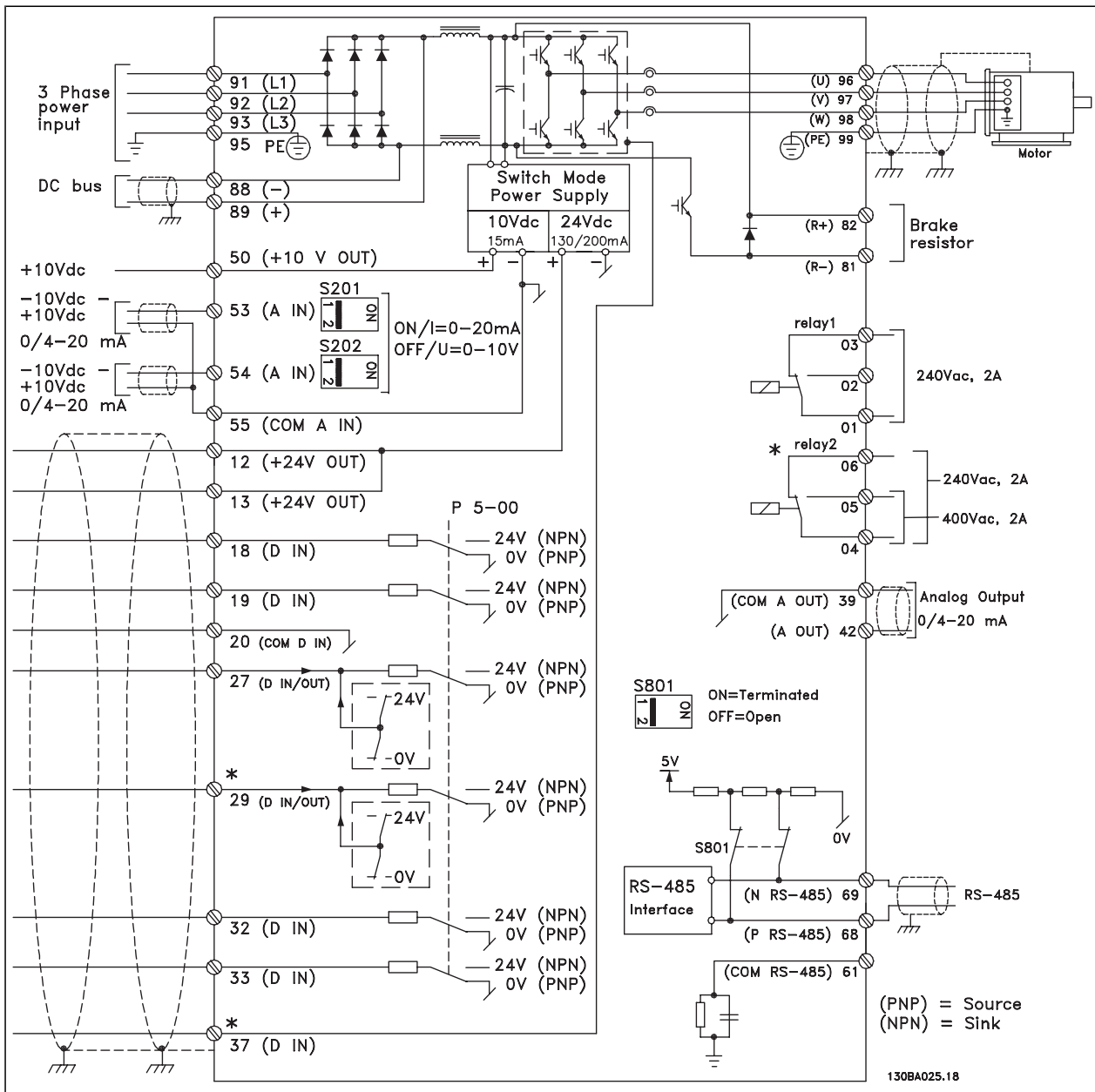

Diagram showing all electrical terminals without options.

Terminal 37 is the input to be used for Safe Stop. For instructions on Safe Stop installation, please refer to the section *Safe Stop Installation* in the FC 300 Design Guide.

\* Terminal 37 is not included in the FC 301 (Except the FC 301 A1, which includes Safe Stop).

Terminal 29 and Relay 2 are not included in FC 301.

— How to Install —

In rare cases, very long control cables and analog signals may, depending on installation, result in 50/60 Hz ground loops due to noise from line supply cables.

If this occurs, it may be necessary to break the shield or insert a 100 nF capacitor between shield and chassis.

The digital and analog inputs and outputs must be connected separately to the FC 300 common inputs (terminal 20, 55, 39) to avoid letting ground currents from both groups affect other groups. For example, switching on the digital input may disturb the analog input signal.

**Input polarity of control terminals**

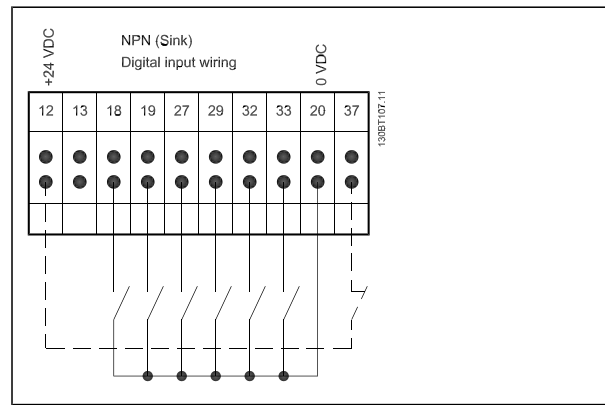
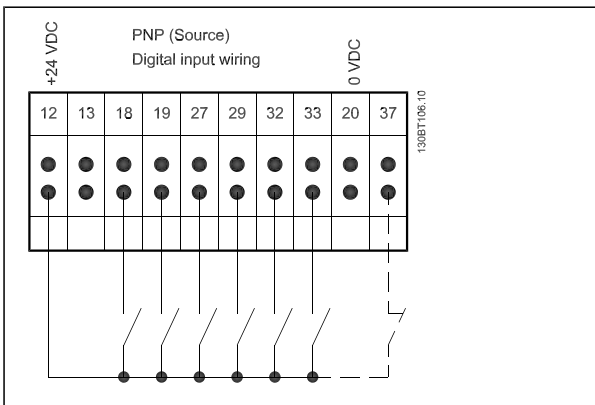

**NOTE**

Control cables must be shield/armored.

See section entitled *Grounding of Shielded/Armored Control Cables* for the correct termination of control cables.

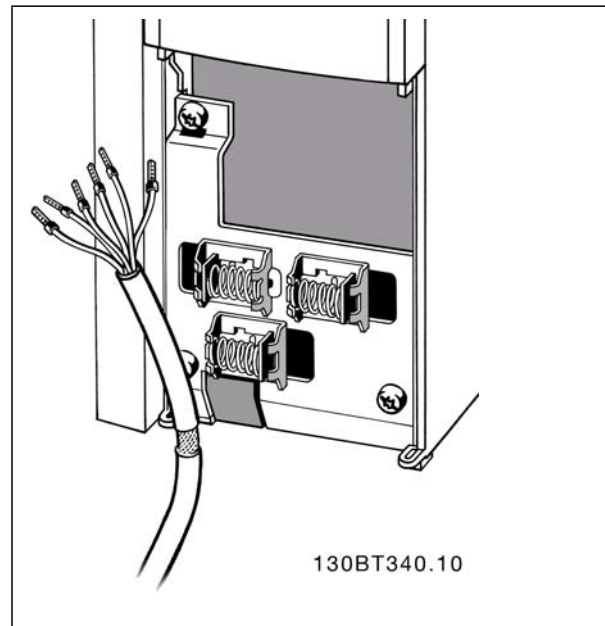

### □ Motor Cables

See section *General Specifications* for correct dimensioning of motor cable cross-section and length.

- Use a shielded/armored motor cable to comply with EMC emission specifications.
- Keep the motor cable as short as possible to reduce the noise level and leakage currents.
- Connect the motor cable shield to both the decoupling plate of the FC 300 and to the metal cabinet of the motor.
- Make the shield connections with the largest possible surface area (cable clamp). This is done by using the supplied installation devices in the FC 300.
- Avoid mounting with twisted shield ends (pigtailed), which will spoil high frequency shielding effects.
- If it is necessary to split the shield to install a motor isolator or motor relay, the shield must be continued with the lowest possible HF impedance.

### □ Electrical Installation of Motor Cables

#### Shielding of cables

Avoid installation with twisted shield ends (pigtailed). They spoil the shielding effect at higher frequencies. If it is necessary to break the shield to install a motor isolator or motor contactor, the shield must be continued at the lowest possible HF impedance.

#### Cable length and cross-section

The adjustable frequency drive has been tested with a given length of cable and a given cross-section of that cable. If the cross-section is increased, the cable capacitance - and thus the leakage current - may increase, thereby requiring that the cable length is reduced correspondingly.

#### Switching frequency

When adjustable frequency drives are used together with LC filters to reduce the acoustic noise from a motor, the switching frequency must be set according to the LC filter instructions in *Par. 14-01*.

#### Aluminum conductors

Aluminum conductors are not recommended. Terminals can accept aluminum conductors, but the conductor surface has to be clean, oxidation must be removed, and the area must be sealed by neutral acid-free Vaseline grease before the conductor is connected.

Furthermore, the terminal screw must be retightened after two days due to the softness of the aluminum. It is crucial to keep the connection a gas-tight joint, otherwise the aluminum surface will oxidize again.

### □ Switches S201, S202, and S801

Switches S201 (A53) and S202 (A54) are used to select a current (0-20 mA) or a voltage (-10 to 10 V) configuration for the analog input terminals 53 and 54, respectively.

Switch S801 (BUS TER.) can be used to enable termination on the RS-485 port (terminals 68 and 69).

See drawing *Diagram showing all electrical terminals* in the *Electrical Installation* section.

Default settings:

S201 (A53) = OFF (voltage input)

S202 (A54) = OFF (voltage input)

S801 (Bus termination) = OFF



When changing the function of S201, S202 or S801, be careful not to force the switch over. Removing the LCP fixture (cradle) when operating the switches is recommended. The switches must not be operated while the adjustable frequency drive is powered.

— How to Install —

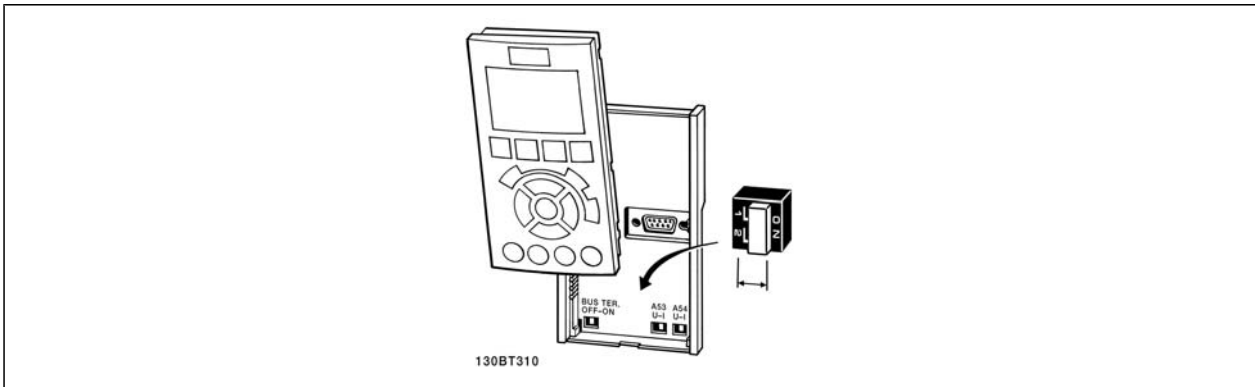

□ Final Set-Up and Test

To test the set-up and ensure that the adjustable frequency drive is running, follow these steps.

Step 1. Locate the motor nameplate.



**NOTE**

The motor is either star (Y) or delta-connected ( $\Delta$ ). This information is located on the motor nameplate data.

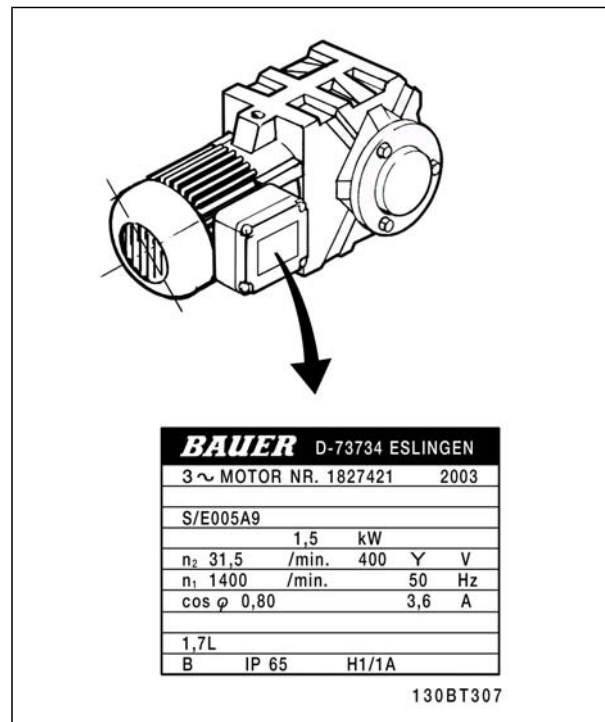

Step 2. Enter the motor nameplate data in this parameter list.

To access this list first press the [QUICK MENU] key, then select "Q2 Quick Setup".

1.	Motor Power [kW] or Motor Power [HP]	par. 1-20 par. 1-21
2.	Motor Voltage	par. 1-22
3.	Motor Frequency	par. 1-23
4.	Motor Current	par. 1-24
5.	Motor Nominal Speed	par. 1-25



### Step 3. Activate the Automatic Motor Adaptation (AMA)

Performing an AMA will ensure optimum performance. The AMA measures the values from the motor model equivalent diagram.

1. Connect terminal 37 to terminal 12 (if terminal 37 is available).
2. Connect terminal 27 to terminal 12, or set par. 5-12 to 'No function' (par. 5-12 [0]).
3. Activate the AMA par. 1-29.
4. Choose between complete or reduced AMA. If a sine-wave filter is mounted, run only the reduced AMA, or remove the sine-wave filter during the AMA procedure.
5. Press the [OK] key. The display shows "Press [Hand on] to start."
6. Press the [Hand on] key. A progress bar indicates if the AMA is in progress.

#### Stop the AMA during operation.

1. Press the [OFF] key. The adjustable frequency drive enters into alarm mode and the display shows that the AMA was terminated by the user.

#### Successful AMA

1. The display shows "Press [OK] to finish AMA."
2. Press the [OK] key to exit the AMA state.

#### Unsuccessful AMA

1. The adjustable frequency drive enters into alarm mode. A description of the alarm can be found in the *Troubleshooting* section.
2. "Report Value" in the [Alarm Log] shows the last measuring sequence carried out by the AMA before the adjustable frequency drive entered alarm mode. This number, along with the description of the alarm, will assist you in troubleshooting. If you contact Danfoss for service, make sure to mention the number and alarm description.



#### NOTE

Unsuccessful AMA is often caused by incorrectly-registered motor nameplate data or too big of a difference between the motor power size and the FC 300 power size.

### Step 4. Set speed limit and ramp time

Set up the desired limits for speed and ramp time.

Minimum Reference	par. 3-02
Maximum Reference	par. 3-03

Motor Speed Low Limit	par. 4-11 or 4-12
Motor Speed High Limit	par. 4-13 or 4-14

Ramp-up Time 1 [s]	par. 3-41
Ramp-down Time 1 [s]	par. 3-42





## □ Additional Connections

### □ DC bus connection

The DC bus terminal is used for DC back-up, with the intermediate circuit being supplied from an external source.

Terminal numbers: 88, 89

Please contact Danfoss if you require further information.

### □ Installing Load Sharing

The connection cable must be shielded, and the max. length from the adjustable frequency drive to the DC bar is 81 ft. [25 m].



**NOTE**

DC bus and load sharing require extra equipment and safety considerations. For further information, see Load Sharing Instructions MI.50.NX.YY.



**NOTE**

Voltages up to 975 V DC (@ 600 V AC) may occur between the terminals.

### □ Brake Connection Option

The connection cable to the brake resistor must be shielded/armored.

No	81	82	Brake resistor
	R-	R+	terminals



**NOTE**

Dynamic brake calls for extra equipment and safety considerations. For further information, please contact Danfoss.

1. Use cable clamps to connect the shield to the metal cabinet of the adjustable frequency drive and to the decoupling plate of the brake resistor.
2. Dimension the cross-section of the brake cable to match the brake current.



**NOTE**

Voltages up to 975 V DC (@ 600 V AC) may occur between the terminals.



**NOTE**

If a short circuit in the brake IGBT occurs, prevent power dissipation in the brake resistor by using a line switch or contactor to disconnect the line power for the adjustable frequency drive. Only the adjustable frequency drive should control the contactor.

### □ Relay Connection

To set relay output, see par. group 5-4\* Relays.



— How to Install —

No.	01 - 02	make (normally open)
	01 - 03	break (normally closed)
	04 - 05	make (normally open)
	04 - 06	break (normally closed)

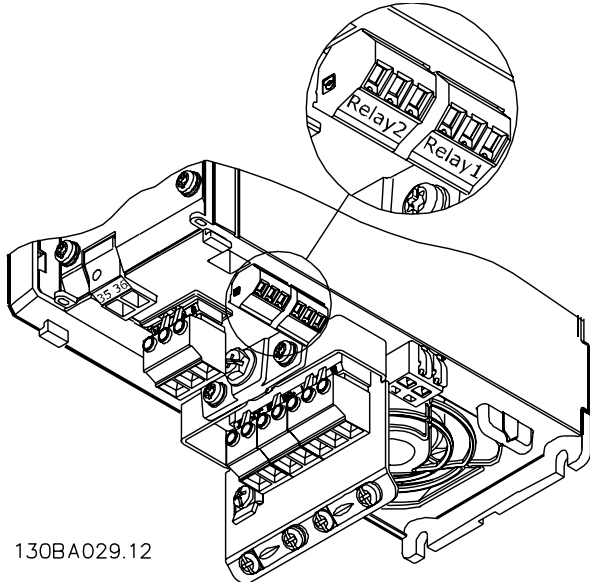

130BA029.12

Terminals for relay connection  
(Frame sizes A1, A2 and A3).

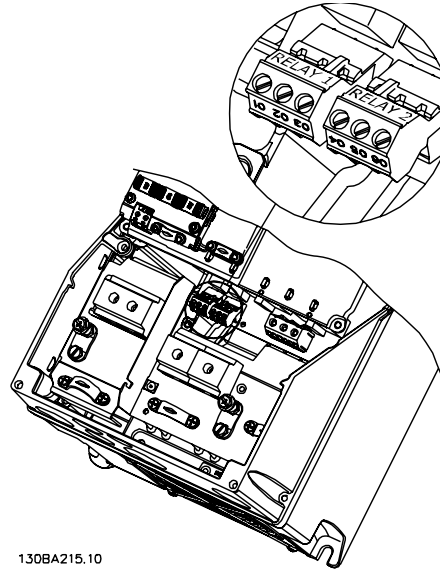

130BA215.10

Terminals for relay connection  
(Frame sizes A5, B1, B2, C1 and C2).



□ **Relay Output**

**Relay 1**

- Terminal 01: common
- Terminal 02: normal open 240 V AC
- Terminal 03: normal closed 240 V AC

**Relay 2 (Not FC 301 ≤10 hp [7.5 kW])**

- Terminal 04: common
- Terminal 05: normal open 400 V AC
- Terminal 06: normal closed 240 V AC

Relay 1 and relay 2 are programmed in par. 5-40, 5-41, and 5-42.

Additional relay outputs by using option module MCB 105.

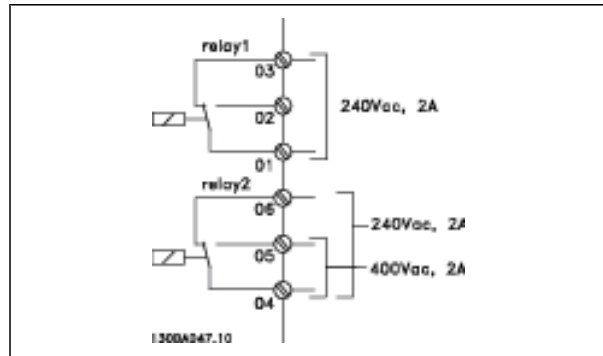

□ **Parallel Connection of Motors**

The adjustable frequency drive can control several parallel-connected motors. The total current consumption of the motors must not exceed the rated output current  $I_{INV}$  for the adjustable frequency drive.

This is only recommended when U/f is selected in par. 1-01.



**NOTE**

Installation with cables connected in a common joint as in illustration 1 is only recommended for short cable lengths.



**NOTE**

When motors are connected in parallel, par. 1-02 *Automatic Motor Adaptation (AMA)* cannot be used, and par. 1-01 *Motor Control Principle* must be set to *Special motor characteristics (U/f)*.

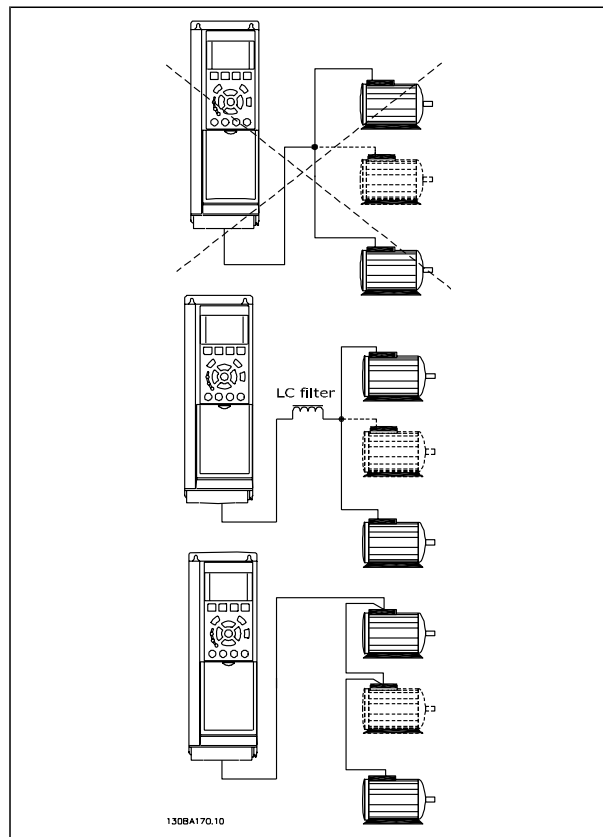

— How to Install —

Problems may arise at start and at low RPM values if motor sizes are widely different, because small motors' relatively high ohmic resistance in the stator calls for a higher voltage at start and at low RPM values.

The electronic thermal relay (ETR) of the adjustable frequency drive cannot be used as motor protection for the individual motor of systems with parallel-connected motors. Provide further motor protection with, for example, thermistors in each motor or individual thermal relays. (Circuit breakers are not a suitable means of protection).

**□ Direction of Motor Rotation**

The default setting is clockwise rotation with the adjustable frequency drive output connected as follows.

- Terminal 96 connected to U-phase
- Terminal 97 connected to V-phase
- Terminal 98 connected to W-phase

The direction of motor rotation is changed by switching two motor phases.

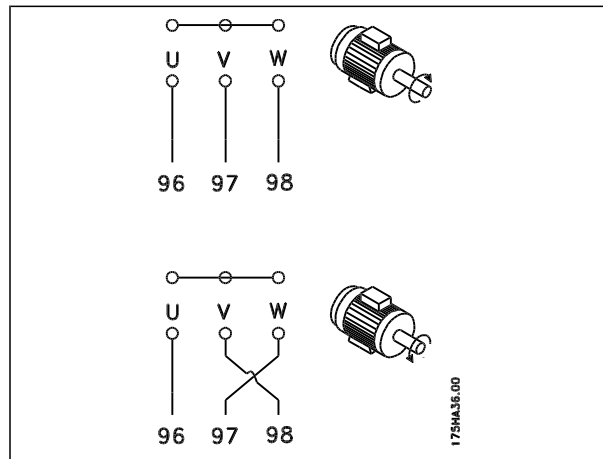

**□ Motor Thermal Protection**

The electronic thermal relay in FC 300 has received the UL-approval for single motor protection, when par. 1-90 *Motor Thermal Protection* is set for *ETR Trip* and par. 1-24 *Motor current, I<sub>M,N</sub>* is set to the rated motor current (see motor nameplate).

**□ Installation of Brake Cable**

(Only for adjustable frequency drives ordered with brake chopper option).

The connection cable to the brake resistor must be shielded.

1. Connect the shield by means of cable clamps to the conductive back plate on the adjustable frequency drive and to the metal cabinet of the brake resistor.
2. Size the brake cable cross-section to match the brake torque.

No.	Function
81, 82	Brake resistor terminals

See Brake instructions, MI.90.FX.YY and MI.50.SX.YY for more information about safe installation.



**NOTE**

Voltages up to 960 V DC, depending on the supply voltage, may occur on the terminals.

□ **RS-485 Bus Connection**

One or more adjustable frequency drives can be connected to a control (or master) using the RS-485 standardized interface. Terminal 68 is connected to the P signal (TX+, RX+), while terminal 69 is connected to the N signal (TX-, RX-).

If more than one adjustable frequency drive is connected to a master, use parallel connections.

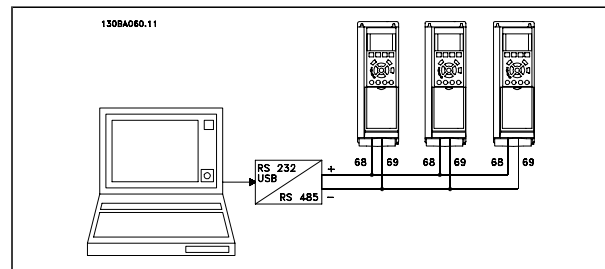

In order to avoid potential equalizing currents in the shield, ground the cable shield via terminal 61, which is connected to the frame via an RC link.

**Bus termination**

The RS-485 bus must be terminated by a resistor network at both ends. For this purpose, set switch S801 on the control card to "ON".

For more information, see the paragraph entitled *Switches S201, S202, and S801*.



**NOTE**

Communication protocol must be set to FC MC par. 8-30.

□ **How to Connect a PC to the FC 300**

To control the adjustable frequency drive from a PC, install the MCT 10 Set-up Software.

The PC is connected via a standard (host/device) USB cable, or via the RS-485 interface as shown in the section *Bus Connection* in the chapter *How to Program*.



**NOTE**

The USB connection is galvanically isolated from the supply voltage (PELV) and other high-voltage terminals. The USB connection is connected to protection ground on the adjustable frequency drive. Only use an isolated laptop as a PC connection to the USB connector on the FC 300 drive.

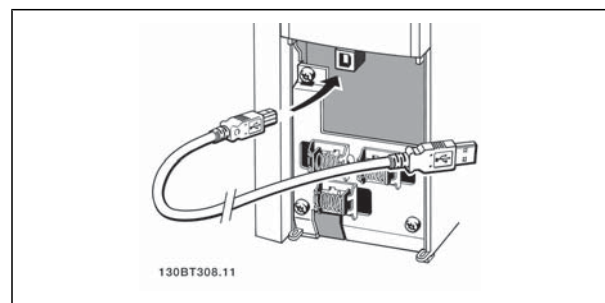

USB connection.



### □ The FC 300 Software Dialog

#### Data storage in PC via MCT 10 Set-up Software:

1. Connect a PC to the unit via the USB com port.
2. Open MCT 10 Set-up software
3. Choose "Read from drive".
4. Choose "Save as".

All parameters are now stored.

#### Data transfer from PC to drive via MCT 10 Set-up software:

1. Connect a PC to the unit via the USB com port.
2. Open MCT 10 Set-up software
3. Choose "Open"— stored files will be shown.
4. Open the appropriate file.
5. Choose "Write to drive."

All parameters are now transferred to the drive.

A separate manual for MCT 10 Set-up software is available.

### □ High Voltage Test

Carry out a high voltage test by short circuiting terminals U, V, W, L<sub>1</sub>, L<sub>2</sub> and L<sub>3</sub>. Energize by max. 2.15 kV DC for one second between this short circuit and the chassis.



#### NOTE

When running high voltage tests of the entire installation, interrupt the mains and motor connection if the leakage currents are too high.

### □ Safety Ground Connection

The adjustable frequency drive has a high leakage current and must be grounded appropriately for safety reasons according to EN 50178.



The ground leakage current from the adjustable frequency drive exceeds 3.5 mA. To ensure a good mechanical connection from the ground cable to the ground connection (terminal 95), the cable cross-section must be at least 0.39 in<sup>2</sup> [10 mm<sup>2</sup>] or 2 rated ground wires terminated separately.

### □ Electrical Installation - EMC Precautions

The following is a guideline to good engineering practice when installing adjustable frequency drives. Follow these guidelines to comply with EN 61800-3 *First environment*. If the installation is in EN 61800-3 *Second environment*, i.e., in industrial networks, or in an installation with its own transformer, deviation from these guidelines is allowed but not recommended. See also paragraphs *CE Labeling*, *General Aspects of EMC Emission* and *EMC Test Results*.

#### Good engineering practice to ensure EMC-correct electrical installation:

- Use only braided shielded/armored motor cables and braided shielded/armored control cables. The shield should provide a minimum coverage of 80%. The shield material must be metal, not limited to, but typically, copper, aluminum, steel or lead. There are no special requirements for the line cable.

## — How to Install —

- Installations using rigid metal conduits are not required to use shielded cable, but the motor cable must be installed in conduit separate from the control and line cables. Full connection of the conduit from the drive to the motor is required. The EMC performance of flexible conduits varies greatly, and information from the manufacturer must therefore be obtained.
- Connect the shield/armor/conduit to ground at both ends for motor cables as well as for control cables. In some cases, it is not possible to connect the shield at both ends. If so, connect the shield at the adjustable frequency drive. See also *Grounding of Braided Shielded/Armored Control Cables*.
- Avoid terminating the shield/armor with twisted ends (pigtailed). It increases the high frequency impedance of the shield, which reduces its effectiveness at high frequencies. Use low-impedance cable clamps or EMC cable glands instead.
- Avoid using unshielded/unarmored motor or control cables inside cabinets housing the drive(s), whenever this can be avoided.

Leave the shield as close to the connectors as possible.

The illustration shows an example of an EMC-correct electrical installation of an IP 20 adjustable frequency drive. The adjustable frequency drive is fitted in an installation cabinet with an output contactor and connected to a PLC, which is installed in a separate cabinet. Other ways of carrying out the installation may result in EMC performance that is equally good, provided the above guide lines for engineering practice are followed.

If the installation is not carried out according to the guidelines, and if non-shielded cables and control wires are used, some emission requirements are not fulfilled, although the immunity requirements are fulfilled. See the paragraph *EMC test results*.



— How to Install —

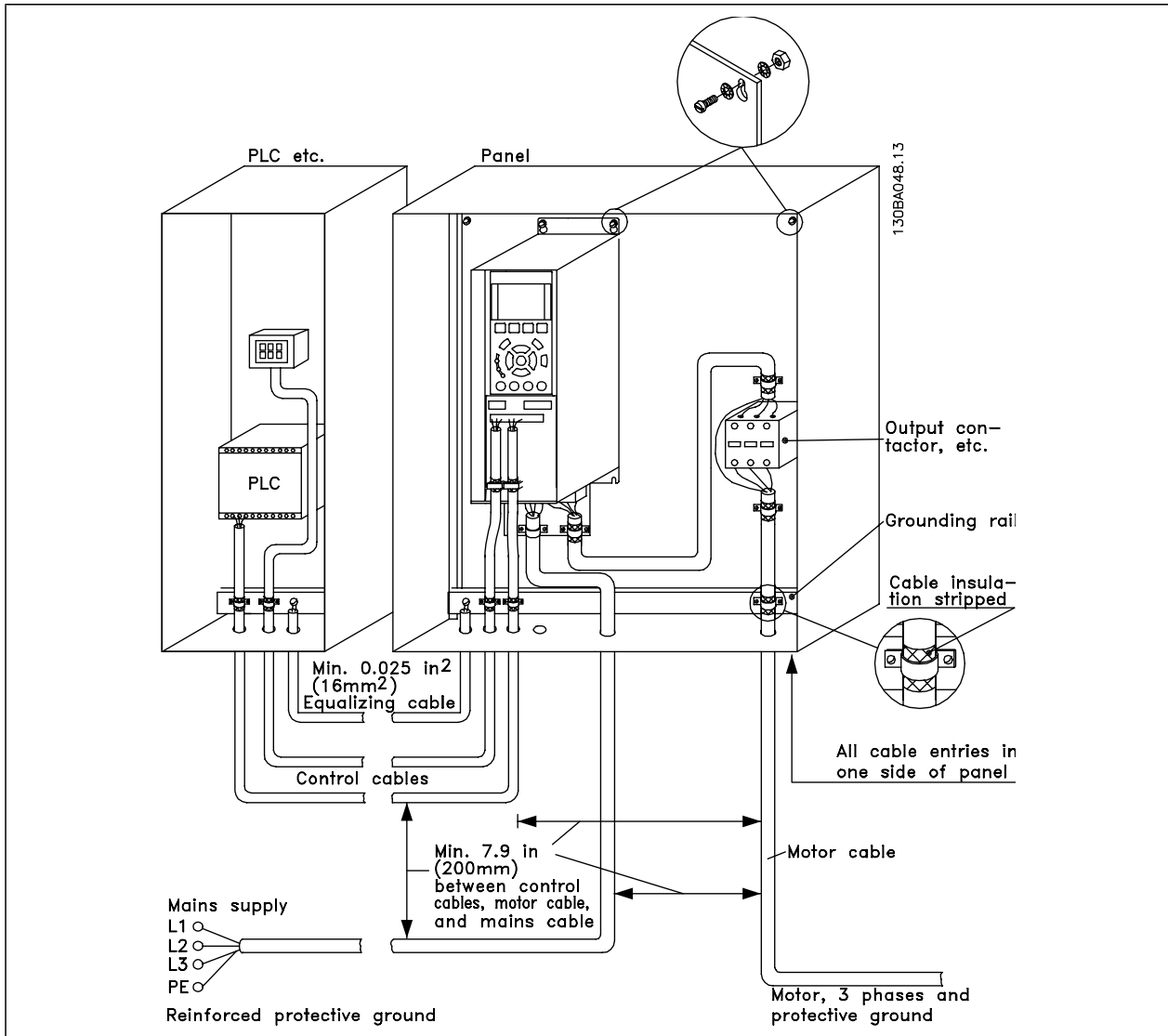

EMC-correct electrical installation of an IP20 adjustable frequency drive.





□ **Use of EMC-Correct Cables**

Danfoss recommends braided shielded/armored cables to optimize EMC immunity of the control cables and the EMC emission from the motor cables.

The ability of a cable to reduce the in and outgoing radiation of electric noise depends on the transfer impedance ( $Z_T$ ). The shield of a cable is normally designed to reduce the transfer of electric noise; however, a shield with a lower transfer impedance ( $Z_T$ ) value is more effective than a shield with a higher transfer impedance ( $Z_T$ ).

Transfer impedance ( $Z_T$ ) is rarely stated by cable manufacturers, but it is often possible to estimate transfer impedance ( $Z_T$ ) by assessing the physical design of the cable.

Transfer impedance ( $Z_T$ ) can be assessed on the basis of the following factors:

- The conductivity of the shield material.
- The contact resistance between the individual shield conductors.
- The shield coverage, i.e., the physical area of the cable covered by the shield - often stated as a percentage value.
- Shield type, i.e., braided or twisted pattern.

- a. Aluminum-clad with copper wire.
- b. Twisted copper wire or armored steel wire cable.
- c. Single-layer braided copper wire with varying percentage shield coverage. This is the typical Danfoss reference cable.
- d. Double-layer braided copper wire.
- e. Twin layer of braided copper wire with a magnetic, shielded/armored intermediate layer.
- f. Cable that runs in copper tube or steel tube.
- g. Lead cable with 0.43 in [1.1 mm] wall thickness.

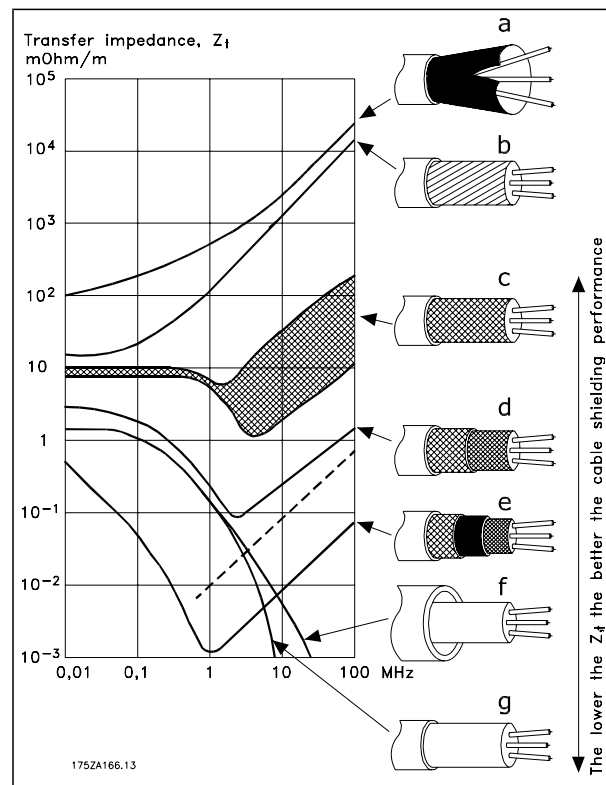

□ **Grounding of Shielded/Armored Control Cables**

Generally speaking, control cables must be braided and shielded/armored, and the shield must be connected by means of a cable clamp at both ends to the metal cabinet of the unit.

The drawing below indicates how correct grounding is carried out and what to do if in doubt.

- a. **Correct grounding**  
Control cables and cables for serial communication must be fitted with cable clamps at both ends to ensure the best possible electrical contact.
- b. **Wrong grounding**  
Do not use twisted cable ends (pigtails). They increase the shield impedance at high frequencies.
- c. **Protection with respect to ground potential between PLC and VLT**  
If the ground potential between the adjustable frequency drive and the PLC (etc.) is different, electric noise may occur that will disturb the entire system. Solve this problem by fitting an equalizing cable next to the control cable. Minimum cable cross-section: 0.025 in<sup>2</sup> [16 mm<sup>2</sup>].
- d. **For 50/60 Hz ground loops**  
If very long control cables are used, 50/60 Hz ground loops may occur. Solve this problem by connecting one end of the shield to ground via a 100nF capacitor (keeping leads short).
- e. **Cables for serial communication**  
Eliminate low-frequency noise currents between two adjustable frequency drives by connecting one end of the shield to terminal 61. This terminal is grounded via an internal RC link. Use twisted-pair cables to reduce the differential mode interference between the conductors.

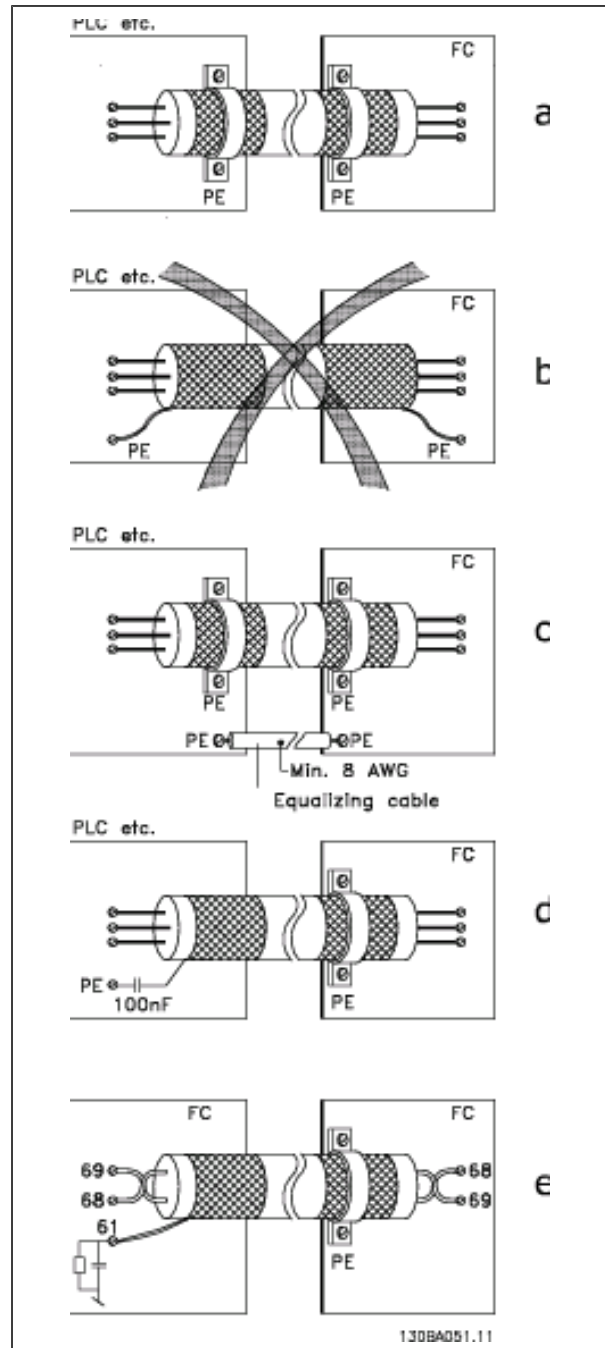

□ **AC Line Supply Interference/Harmonics**

An adjustable frequency drive takes up a non-sinusoidal current from the line power, which increases the input current  $I_{RMS}$ . A non-sinusoidal current is transformed by means of a Fourier analysis and split up into sine-wave currents with different frequencies, i.e., different harmonic currents  $I_N$  with 50 Hz as their basic frequency:

Harmonic currents	$I_1$	$I_5$	$I_7$
Hz	50 Hz	250 Hz	350 Hz

The harmonics do not affect the power consumption directly, but they do increase the heat losses in the installation (transformer, cables). Consequently, in plants with a high percentage of rectifier load, maintain harmonic currents at a low level to prevent an overload of the transformer and high temperature in the cables.

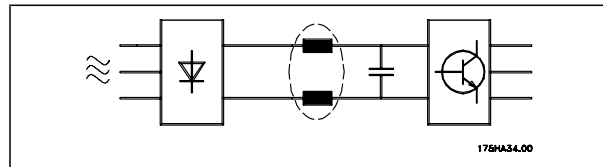

**NOTE**

Some of the harmonic currents might disturb communication equipment connected to the same transformer or cause resonance in connection with power-factor correction batteries.

Harmonic currents compared to the RMS input current:

	Input current
$I_{RMS}$	1.0
$I_1$	0.9
$I_5$	0.4
$I_7$	0.2
$I_{11-49}$	< 0.1

To ensure low harmonic currents, the adjustable frequency drive is standard-equipped with intermediate circuit coils. This normally reduces the input current  $I_{RMS}$  by 40%.

The voltage distortion in the line supply depends on the size of the harmonic currents multiplied by the line power impedance for the frequency in question. The total voltage distortion THD is calculated on the basis of the individual voltage harmonics using this formula:

$$THD\% = \sqrt{U\frac{2}{5} + U\frac{2}{7} + \dots + U\frac{2}{N}}$$

( $U_N\%$  of  $U$ )

□ **Residual Current Device**

You can use RCD relays, multiple protective grounding or grounding as extra protection, provided that local safety regulations are complied with.

If a ground fault appears, a DC content may develop in the faulty current.

If RCD relays are used, you must observe local regulations. Relays must be suitable for protection of 3-phase equipment with a bridge rectifier and for a brief discharge on power-up see section *Ground Leakage Current* for further information.





## Application Examples

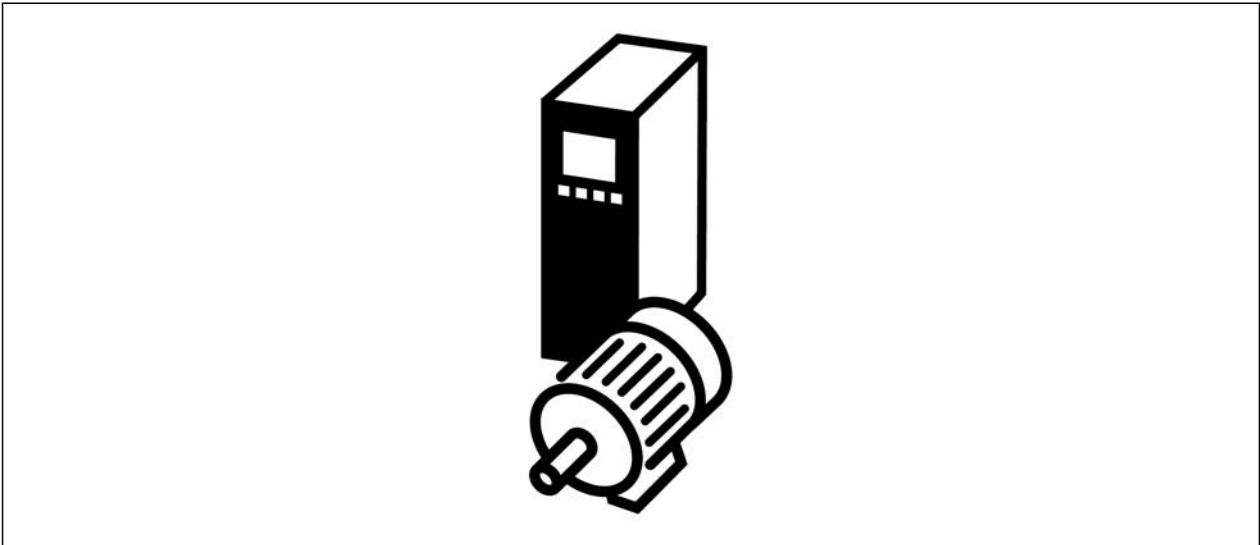

### □ Start/Stop

Terminal 18 = Par. 5-10 [8] *Start*

Terminal 27 = Par. 5-12 [0] *No operation (Default coast inverse)*

Terminal 37 = Safe stop (FC 302 and FC 301 A1 only)

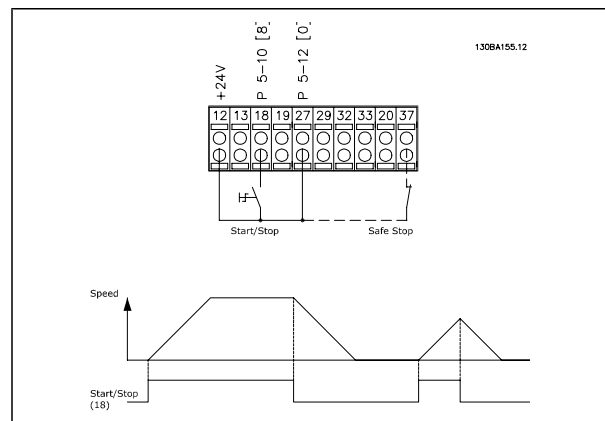

### □ Pulse Start/Stop

Terminal 18 = Par. 5-10 [9] *Latched start*

Terminal 27 = Par. 5-12 [6] *Stop inverse*

Terminal 37 = Safe stop (FC 302 and FC 301 A1 only)



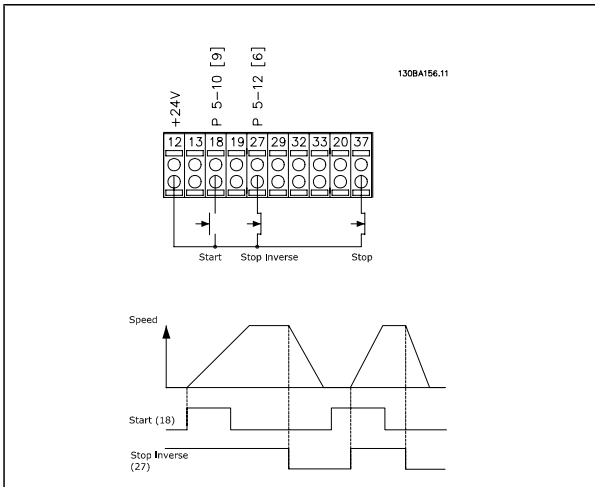

**□ Potentiometer Reference**

Voltage reference via a potentiometer.

Reference Source 1 = [1] Analog input 53 (default)

Terminal 53, Low Voltage = 0 Volt

Terminal 53, High Voltage = 10 Volt

Terminal 53, Low Ref./Feedback = 0 RPM

Terminal 53, High Ref./Feedback = 1,500 RPM

Switch S201 = OFF (U)

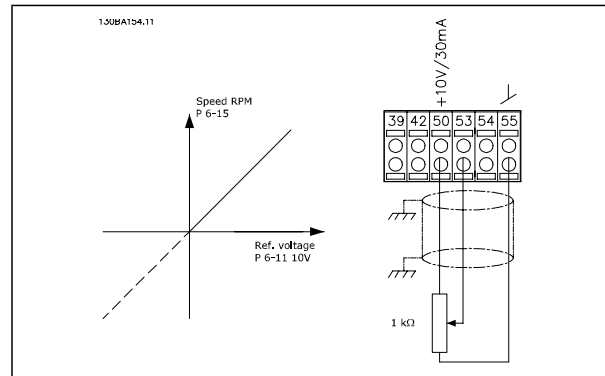

**□ Encoder Connection**

The purpose of this guideline is to ease the set-up of encoder connection to the FC 302. Before setting up the encoder, the basic settings for a closed-loop speed control system will be shown.

**Encoder Connection to FC 302**

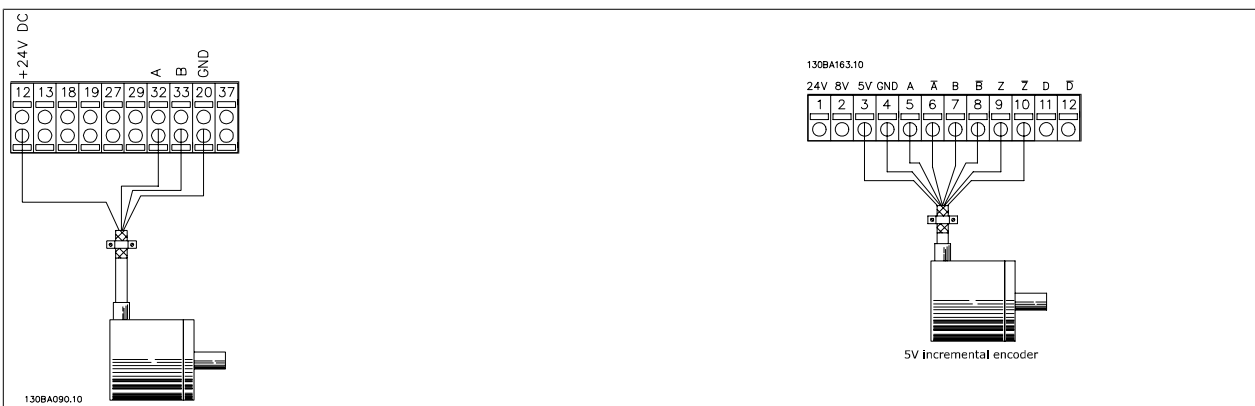

□ **Encoder Direction**

The direction of the encoder is determined by which order the pulses are entering the drive.  
 A clockwise direction means channel A is 90 electrical degrees before channel B.  
 A counter clockwise direction means channel B is 90 electrical degrees before A.  
 The direction is determined by looking into the shaft end.

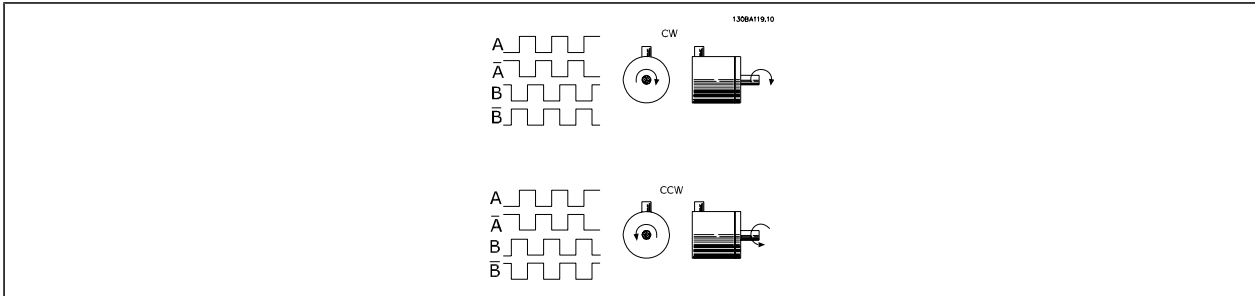

□ **Closed-loop Drive System**

A drive system usually consists of multiple elements such as:

- Motor
- Add (Gearbox) (Mechanical Brake)
- FC 302 AutomationDrive
- Encoder as feedback system
- Brake resistor for dynamic braking
- Transmission
- Load

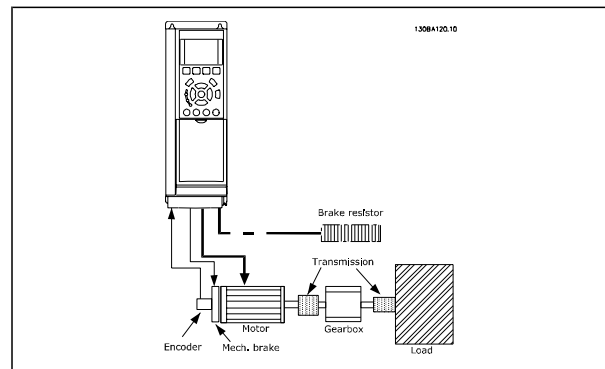

**Basic Set-up for FC 302 Closed-loop Speed Control**

Applications demanding mechanical brake control will usually need a brake resistor.

□ **Programming of Torque Limit and Stop**

In applications with an external electro-mechanical brake, such as hoisting applications, it is possible to stop the adjustable frequency drive via a 'standard' stop command and simultaneously activate the external electro-mechanical brake.

The example given below illustrates the programming of adjustable frequency drive connections. The external brake can be connected to relay 1 or 2; see paragraph *Control of Mechanical Brake*. Program terminal 27 to Coast inverse [2] or Coast and reset inv. [3], and program terminal 29 to Terminal mode 29 Output [1] and Torque limit stop [27].

Description:

If a stop command is active via terminal 18 and the adjustable frequency drive is not at the torque limit, the motor ramps down to 0 Hz.

If the adjustable frequency drive is at the torque limit and a stop command is activated, terminal 29 Output (programmed to Torque limit stop [27]) is activated. The signal to terminal 27 changes from 'logic



1' to 'logic 0', and the motor starts to coast, thereby ensuring that the hoist stops even if the adjustable frequency drive itself cannot handle the required torque (i.e., due to excessive overload).

- Start/stop via terminal 18  
Par. 5-10 Start [8]
- Quickstop via terminal 27  
Par. 5-12 Coast inverse [2]
- Terminal 29 Output  
Par. 5-02 Terminal 29 Mode Output [1]  
Par. 5-31 Torque limit stop [27]
- Relay output [0] (Relay 1)  
Par. 5-40 Mech. Brake Control [32]

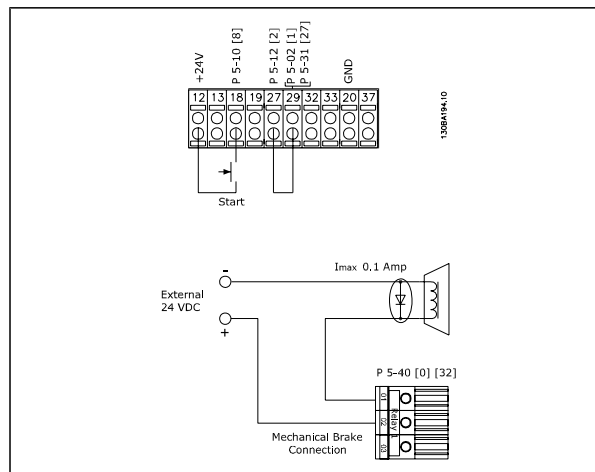

#### □ Automatic Motor Adaptation (AMA)

AMA is an algorithm to measure the electrical motor parameters on a motor at standstill. This means that AMA itself does not supply any torque.

AMA is useful when commissioning systems and optimizing the adjustment of the adjustable frequency drive to the applied motor. In particular, this feature is used where the default setting does not apply to the connected motor.

Par. 1-29 allows a choice of complete AMA with determination of all electrical motor parameters or reduced AMA with determination of the stator resistance  $R_s$  only.

The duration of a total AMA varies from a few minutes on small motors to more than 15 minutes on large motors.

#### Limitations and preconditions:

- For the AMA to determine the motor parameters optimally, enter the correct motor nameplate data in par. 1-20 to 1-26.
- For the best adjustment of the adjustable frequency drive, carry out an AMA on a cold motor. Repeated AMA runs may lead to a heating of the motor, which results in an increase of the stator resistance,  $R_s$ . Normally, this is not critical.
- An AMA can only be carried out if the rated motor current is a minimum 35% of the rated output current of the adjustable frequency drive. An AMA can be carried out on up to one oversized motor.
- It is possible to carry out a reduced AMA test with an LC filter installed. Avoid carrying out a complete AMA with an LC filter. If an overall setting is required, remove the LC filter while running a total AMA. After completion of the AMA, reinsert the LC filter.
- If motors are coupled in parallel, use only a reduced AMA if any.
- Avoid running a complete AMA when using synchronous motors. If synchronous motors are applied, run a reduced AMA and manually set the extended motor data. The AMA function does not apply to permanent magnet motors.





## — Application Examples —

- The adjustable frequency drive does not produce motor torque during an AMA. During an AMA, it is imperative that the application does not force the motor shaft to run, which is known to happen with windmilling in ventilation systems, for example. This disturbs the AMA function.

### □ Smart Logic Control Programming

A new useful feature in the FC 302 is the Smart Logic Control (SLC).

In applications where a PLC generates a simple sequence, the SLC may take over elementary tasks from the main control.

SLC is designed to act from event sent to or generated in the FC 302. The adjustable frequency drive will then perform the pre-programmed action.

### □ SLC Application Example

One sequence 1:

Start – ramp-up – run at reference speed 2 sec – ramp-down and hold shaft until stop.

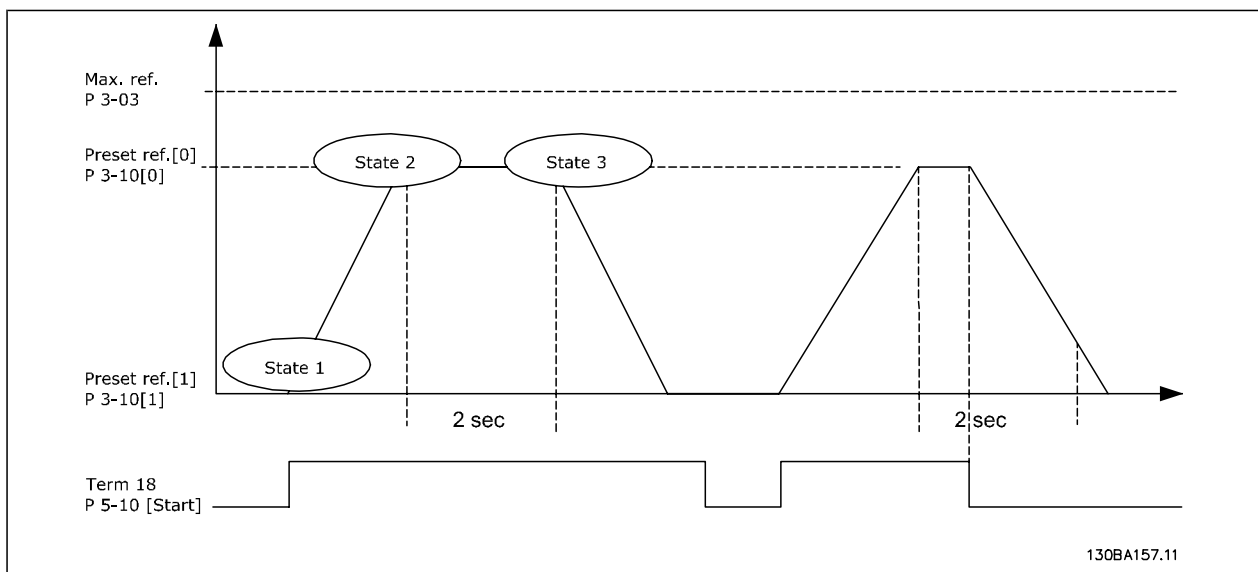

Set the ramping times in par. 3-41 and 3-42 to the desired times.

$$t_{ramp} = \frac{t_{acc} \times n_{norm} (par. 1 - 25)}{\Delta ref [RPM]}$$

Set term 27 to *No Operation* (par. 5-12)

Set Preset reference 0 to first preset speed (par. 3-10 [0]) in percentage of Max Reference speed (par. 3-03). Ex.: 60%

Set preset reference 1 to second preset speed (par. 3-10 [1]) Ex.: 0% (zero).

Set the timer 0 for constant running speed in par. 13-20 [0]. Ex.: 2 sec.

Set Event 1 in par. 13-51 [1] to *True* [1]

Set Event 2 in par. 13-51 [2] to *On Reference* [4]

Set Event 3 in par. 13-51 [3] to *Time Out 0* [30]

Set Event 4 in par. 13-51 [1] to *False* [0]

Set Action 1 in par. 13-52 [1] to *Select preset 0* [10]

Set Action 2 in par. 13-52 [2] to *Start Timer 0* [29]

Set Action 3 in par. 13-52 [3] to *Select preset 1* [11]

Set Action 4 in par. 13-52 [4] to *No Action* [1]



— Application Examples —

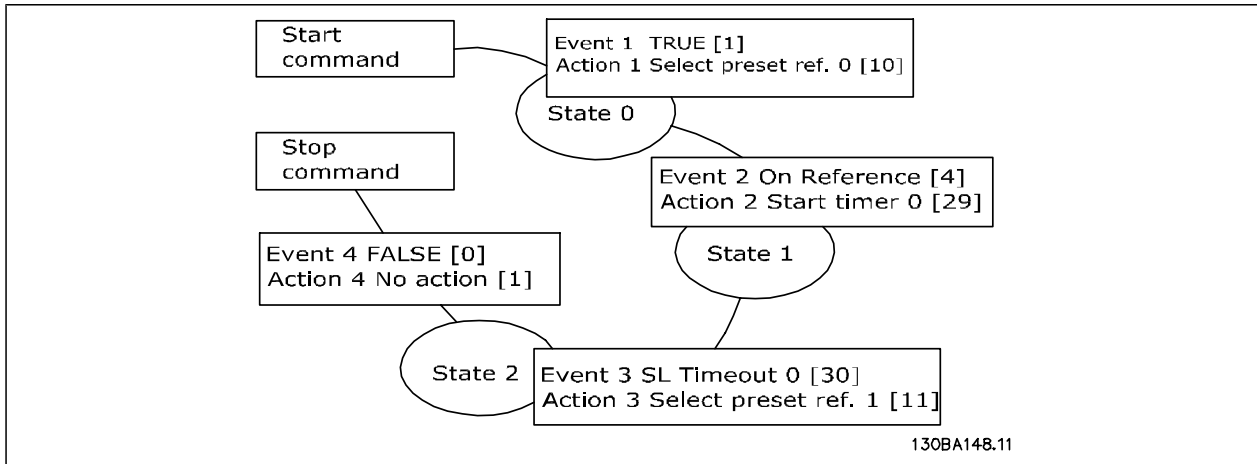

Set the Smart Logic Control in par. 13-00 to ON.

Start / stop command is applied on terminal 18. If stop signal is applied, the adjustable frequency drive will ramp down and go into free mode.



## □ Options and Accessories

Danfoss offers a wide range of options and accessories for VLT AutomationDrive FC 300 Series.

### □ Mounting Option Modules in Slot B

The power to the adjustable frequency drive must be disconnected.

Ensuring that the parameter data is saved (i.e., by MCT10 software ) before option modules are inserted/ removed from the drive is strongly recommended.

- Remove the LCP (Local Control Panel), the terminal cover and the LCP frame from the adjustable frequency drive.
- Insert the MCB10x option card into slot B.
- Connect the control cables and fasten the cables with the enclosed cable strips.  
\* Remove the knock out in the extended LCP frame, so that the option will fit under the extended LCP frame.
- Fit the extended LCP frame and terminal cover.
- Fit the LCP or blind cover in the extended LCP frame.
- Connect power to the adjustable frequency drive.
- Set up the input/output functions in the corresponding parameters, as mentioned in the section *General Technical Data*.

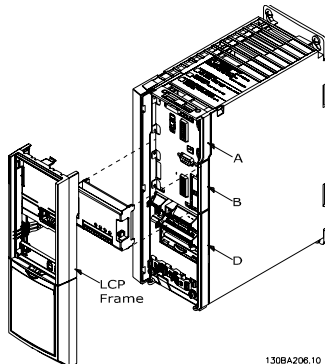

Frame sizes A1, A2 and A3

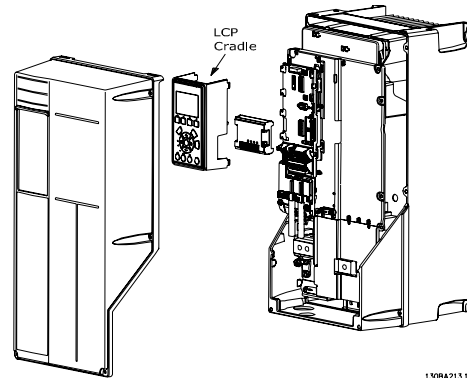

Frame sizes A5, B1, B2, C1 and C2

### □ General Purpose Input Output Module MCB 101

The MCB 101 is used for extension of digital and analog inputs and outputs of the FC 301 and FC 302 AutomationDrive.

Contents: The MCB 101 must be inserted in slot B in the AutomationDrive.

- MCB 101 option module
- Extended fixture for LCP
- Terminal cover

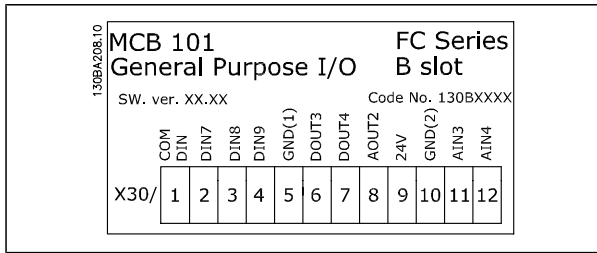

□ **Galvanic Isolation in the MCB 101**

Digital/analog outputs in the MCB 101 are galvanically isolated from other inputs/outputs on the MCB 101, but not from the ones on the control card of the drive. Digital/analog outputs in the MCB 101 are galvanically isolated from other inputs/outputs on the MCB 101, but not from these on the control card of the drive.

If digital inputs 7, 8 or 9 are to be switched using the internal 24 V power supply (terminal 9), the connection between terminal 1 and 5 illustrated in the drawing has to be established.

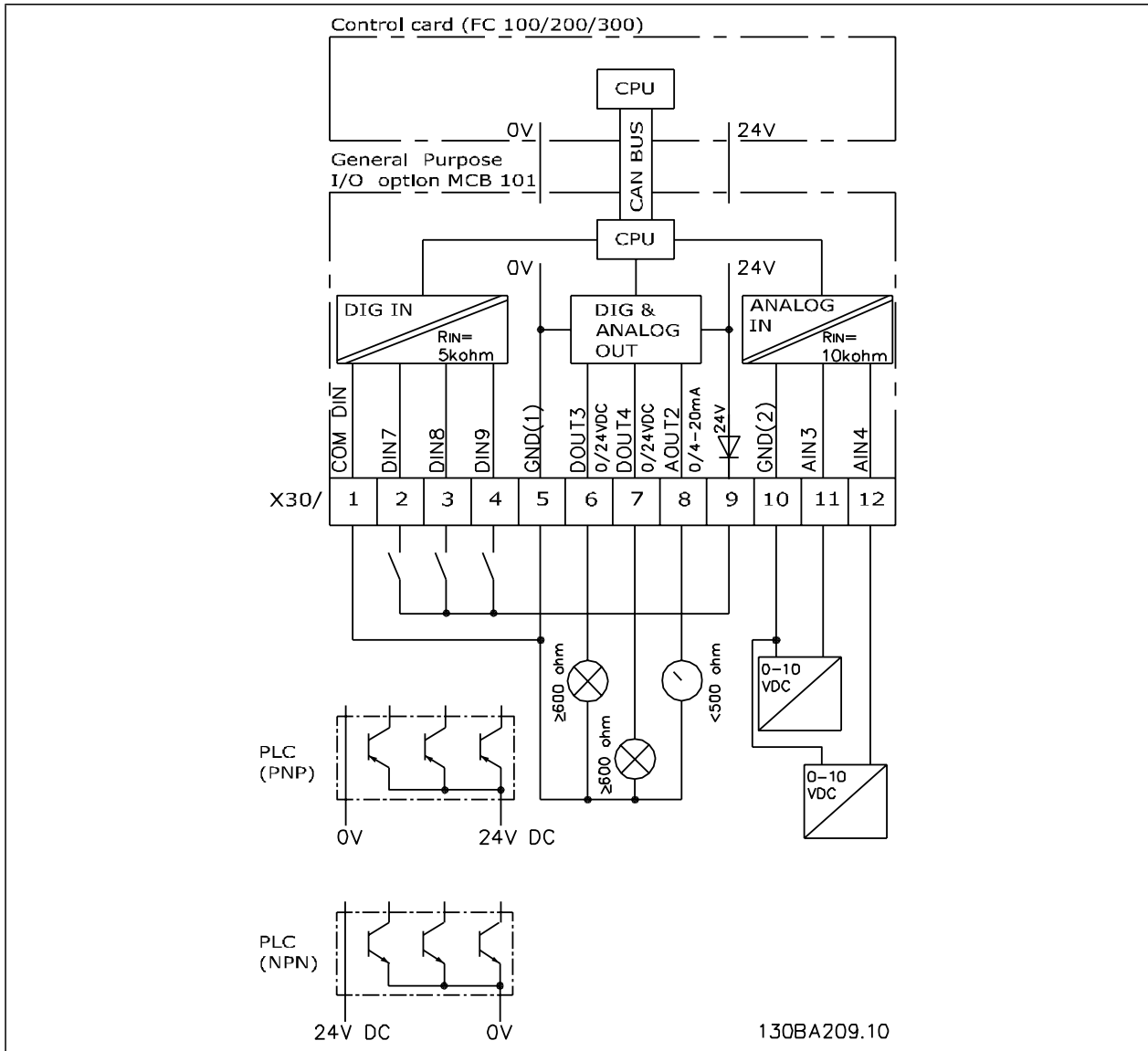

Principle Diagram

**Digital inputs - Terminal X30/1-4**

Digital input:

Number of digital inputs	3
Terminal number	X30.2, X30.3, X30.4
Logic	PNP or NPN
Voltage level	0-24 V DC
Voltage level, logic '0' PNP (GND = 0 V)	< 5 V DC
Voltage level, logic '1' PNP (GND = 0 V)	> 10 V DC
Voltage level, logic '0' NPN (GND = 24V)	< 14 V DC
Voltage level, logic '1' NPN (GND = 24 V)	> 19 V DC
Maximum voltage on input	28 V continuous
Pulse frequency range	0-110 kHz

Duty cycle, min. pulse width	4.5 ms
Input impedance	> 2 kΩ

**Analog inputs - Terminal X30/11, 12:**

## Analog input:

Number of analog inputs	2
Terminal number	X30.11, X30.12
Modes	Voltage
Voltage level	0-10 V
Input impedance	> 10 kΩ
Max. voltage	20 V
Resolution for analog inputs	10 bit (+ sign)
Accuracy of analog inputs	Max. error 0.5% of full scale
Bandwidth	FC 301: 20 Hz/ FC 302: 100 Hz

**Digital outputs - Terminal X30/6, 7:**

## Digital output:

Number of digital outputs	2
Terminal number	X30.6, X30.7
Voltage level at digital/frequency output	0-24 V
Max. output current	40 mA
Max. load	≥ 600 Ω
Max. capacitive load	< 10 nF
Minimum output frequency	0 Hz
Maximum output frequency	≤ 32 kHz
Accuracy of frequency output	Max. error: 0.1% of full scale

**Analog output - Terminal X30/8:**

## Analog output:

Number of analog outputs	1
Terminal number	X30.8
Current range at analog output	0 - 20 mA
Max. load GND - analog output	500 Ω
Accuracy on analog output	Max. error: 0.5% of full scale
Resolution on analog output	12 bit

**□ Encoder Option MCB 102**

The encoder module can be used as feedback source for closed-loop flux control (par. 1-02), as well as closed-loop speed control (par. 7-00). Configure encoder option in parameter group 17-xx

Used for:

- VVC<sup>plus</sup> closed-loop
- Flux vector speed control
- Flux vector torque control
- Permanent magnet motor

## Supported encoder types:

Incremental encoder: 5 V TTL type, RS422, max. frequency: 410 kHz

Incremental encoder: 1Vpp, sine-cosine

Hiperface® Encoder: Absolute and Sine-Cosine (Stegmann/SICK)

— Options and Accessories —

EnDat encoder: Absolute and Sine-Cosine (Heidenhain) Supports version 2.1

SSI encoder: Absolute

Encoder monitor:

The 4 encoder channels (A, B, Z, and D) are monitored, open and short circuit can be detected. There is a green LED for each channel which lights up when the channel is OK.



**NOTE**

The LEDs are only visible when removing the LCP. Reaction in case of an encoder error can be selected in par. 17-61: None, Warning or Trip.

When the encoder option kit is ordered separately, it includes:

- Encoder module MCB 102
- Enlarged LCP fixture and enlarged terminal cover

The encoder option does not support FC 302 adjustable frequency drives manufactured before week 50/2004.

Min. software version: 2.03 (par. 15-43)

Connector Designation X31	Incremental Encoder (please refer to Graphic A)	SinCos Encoder Hiperface® (please refer to Graphic B)	EnDat Encoder	SSI Encoder	Description
1	NC			24 V	24 V Output
2	NC	8 Vcc			8 V Output
3	5 VCC		5 VCC	5 V	5 V Output
4	GND		GND	GND	GND
5	A input	+COS	+COS	A input	A input
6	A inv input	REFCOS	REFCOS	A input inv.	A inv input
7	B input	+SIN	+SIN	B input	B input
8	B inv input	REFSIN	REFSIN	B input inv.	B inv input
9	Z input	+Data RS485	Clock out	Clock out	Z input OR +Data RS485
10	Z inv input	-Data RS485	Clock out inv.	Clock out inv.	Z input OR -Data RS485
11	NC	NC	Data in	Data in	Future use
12	NC	NC	Data in inv.	Data in inv.	Future use

Max. 5 V on X31.5-12

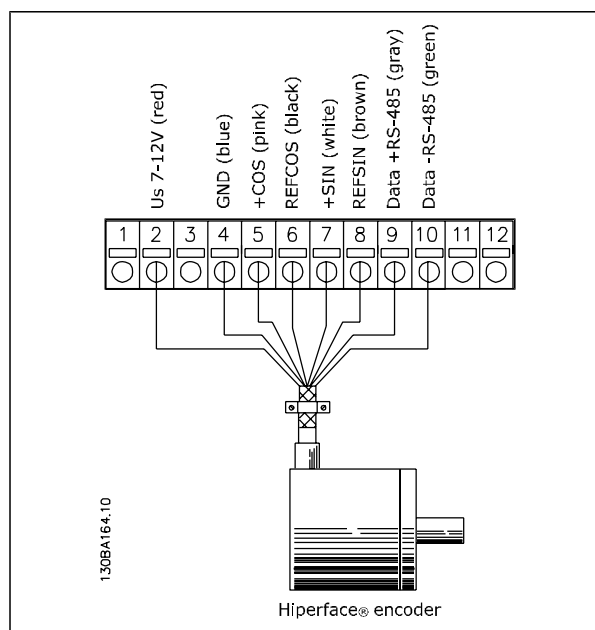
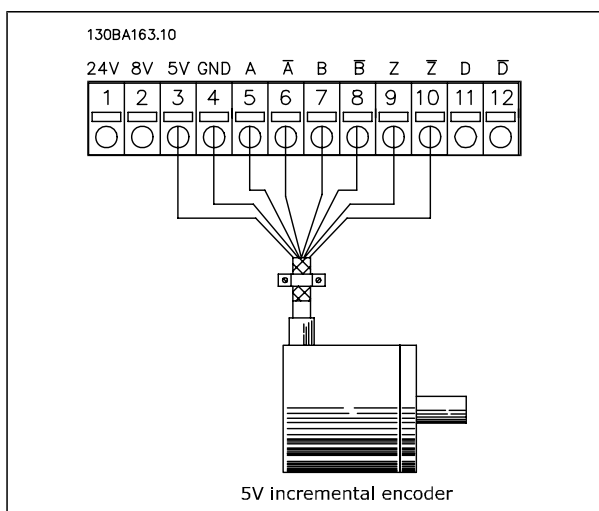

▣ **Resolver Option MCB 103**

The MCB 103 resolver option is used for interfacing with the resolver motor feedback to FC 300 AutomationDrive. Resolvers are used basically as motor feedback device for permanent magnet brushless synchronous motors. When the resolver option is ordered separately the kit includes:

- Resolver option MCB 103
- Enlarged LCP fixture and enlarged terminal cover

17-5x resolver interface. 17-5x resolver interface.

The MCB 103 resolver option supports various resolver types.

Resolver specifications:		
Resolver Poles		Par. 17-50: 2 *2
Resolver Voltage	Input	Par. 17-51: 2.0–8.0 Vrms *7.0 Vrms
Resolver Frequency	Input	Par. 17-52: 2–15 kHz *10.0 kHz
Transformation ratio		Par. 17-53: 0.1 – 1.1 *0.5
Secondary voltage	input	Max 4 Vrms
Secondary load		App. 10 kΩ



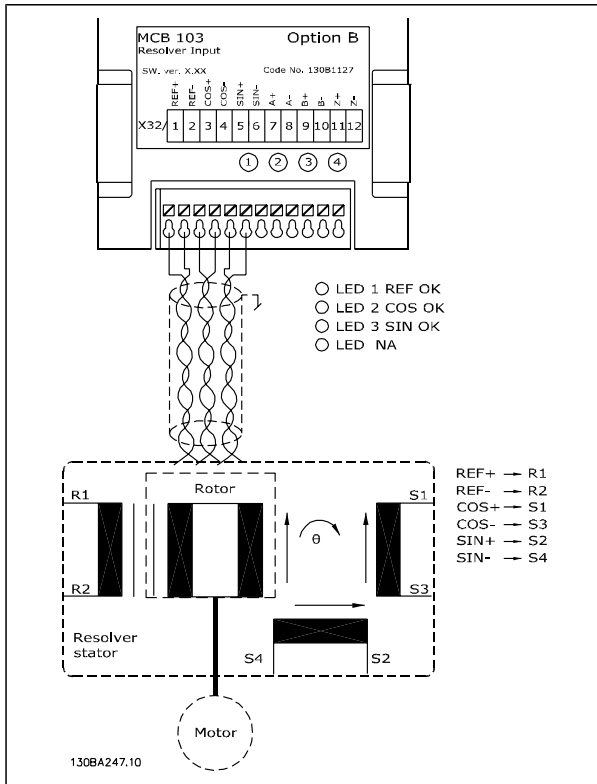

**NOTE**

The resolver option MCB 103 can only be used with rotor-supplied resolver types. Stator-supplied resolvers cannot be used.

**LED indicators**

LED 1 is on when the reference signal is OK to resolver

LED 2 is on when cosine signal is OK from resolver

LED 3 is on when sine signal is OK from resolver

The LEDs are active when par. 17-61 is set to *Warning* or *Trip*.

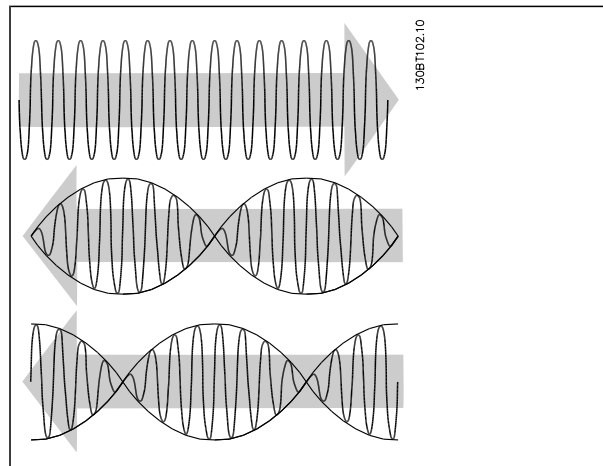

**Set-up example**

In this example, a permanent magnet (PM) motor is used with resolver as speed feedback. A PM motor must usually operate in flux mode.

**Wiring:**

The max cable length is 490 ft [150 m] when a twisted-pair cable is used.



**NOTE**

Resolver cables must be shielded and separated from the motor cables.



**NOTE**

The shield of the resolver cable must be correctly connected to the de-coupling plate, and connected to chassis (ground) on the motor side.



**NOTE**

Always use shielded motor cables and brake chopper cables.

Adjust the following parameters:		
Par. 1-00	Configuration Mode	Speed closed-loop [1]
Par. 1-01	Motor Control Principle	Flux with feedback [3]
Par. 1-10	Motor Construction	PM, non-salient SPM [1]
Par. 1-24	Motor Current	Nameplate
Par. 1-25	Motor Nominal Speed	Nameplate
Par. 1-26	Motor Cont. Rated Torque	Nameplate
AMA is not possible on PM motors		
Par. 1-30	Stator Resistance	Motor data sheet
Par. 1-37	d-axis inductance (Ld)	Motor data sheet (mH)
Par. 1-39	Motor Poles	Motor data sheet
Par. 1-40	Back EMF at 1000 RPM	Motor data sheet
Par. 1-41	Motor Angle Offset	Motor data sheet (Usually zero)
Par. 17-50	Poles	Resolver data sheet
Par. 17-51	Input Voltage	Resolver data sheet
Par. 17-52	Input Frequency	Resolver data sheet
Par. 17-53	Transformation Ratio	Resolver data sheet
Par. 17-59	Resolver Interface	Enabled [1]

**□ Relay Option MCB 105**

The MCB 105 option includes 3 pieces of SPDT contacts and must be fitted into option slot B.

**Electrical Data:**

Max terminal load (AC-1) <sup>1)</sup> (Resistive load)	240 V AC 2A
Max terminal load (AC-15) <sup>1)</sup> (Inductive load @ cosφ 0.4)	240 V AC 0.2 A
Max terminal load (DC-1) <sup>1)</sup> (Resistive load)	24 V DC 1 A
Max terminal load (DC-13) <sup>1)</sup> (Inductive load)	24 V DC 0.1 A
Min terminal load (DC)	5 V 10 mA
Max switching rate at rated load/min load	6 min <sup>-1</sup> /20 sec <sup>-1</sup>

*1) IEC 947 part 4 and 5*

When the relay option kit is ordered separately, the kit includes:

- Relay Module MCB 105
- Enlarged LCP fixture and enlarged terminal cover

- Label for covering access to switches S201, S202 and S801
- Cable strips for fastening cables to relay module

The relay option does not support FC 302 adjustable frequency drive s manufactured before week 50/2004.

Min. software version: 2.03 (par. 15-43).

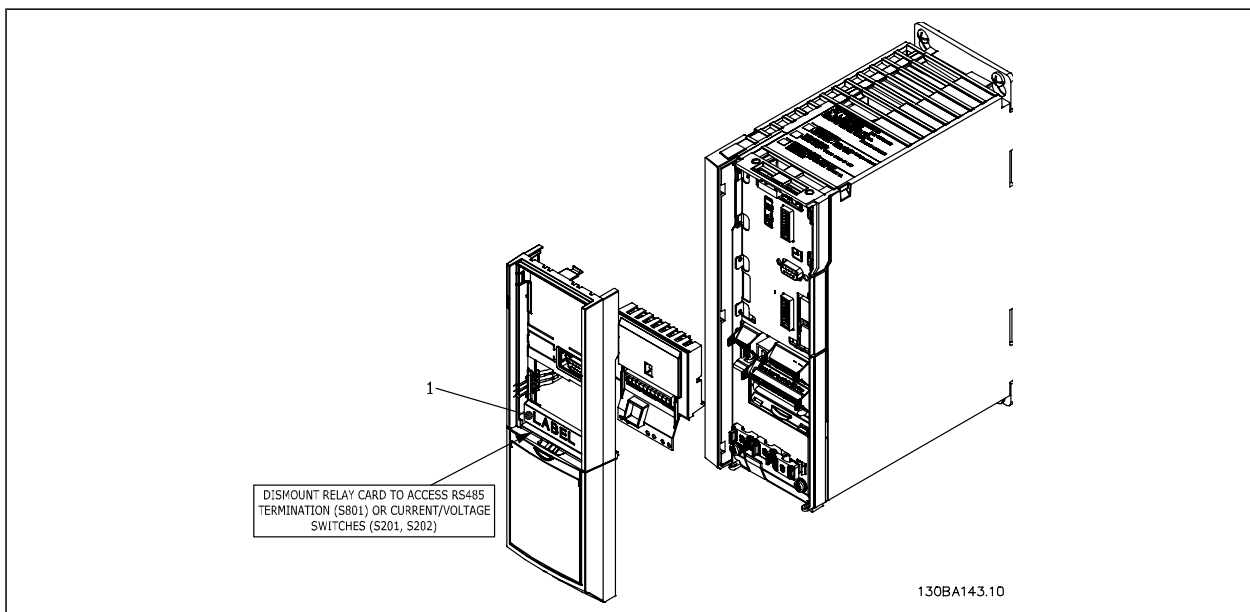

Frame sizes A1, A2 and A3

**IMPORTANT**

1. The label **MUST** be placed on the LCP frame as shown (UL-approved).

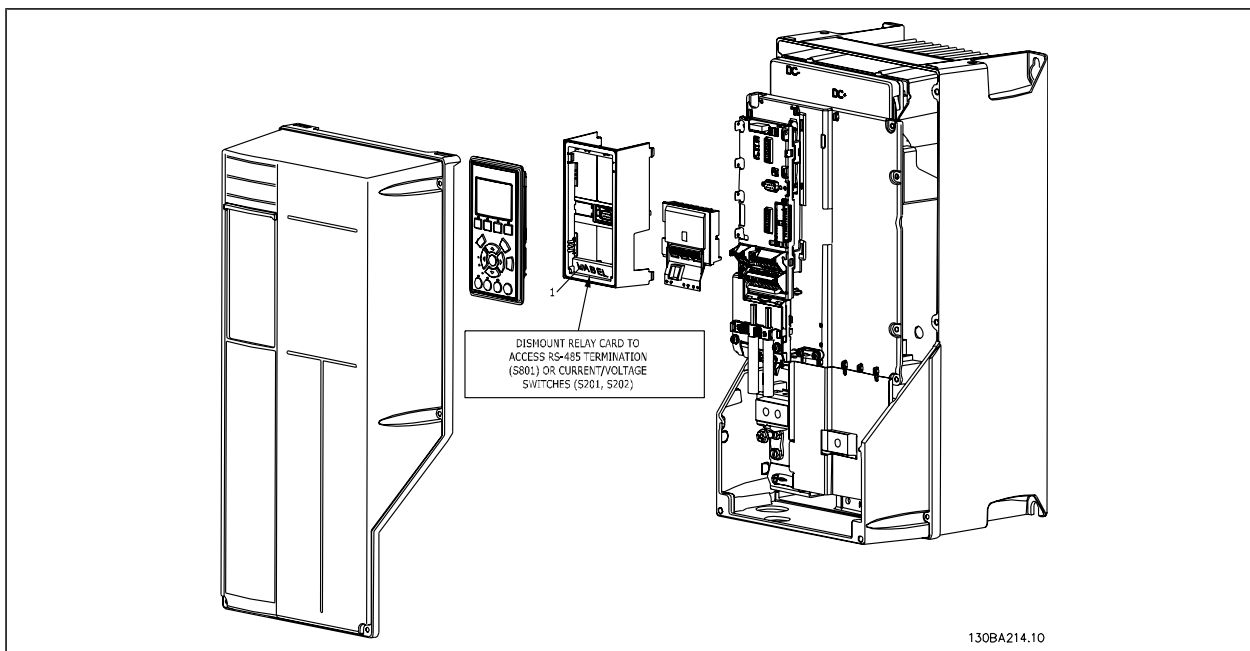

Frame sizes A5, B1, B2, C1 and C2

**IMPORTANT**

1. The label **MUST** be placed on the LCP frame as shown (UL-approved).



Warning Dual supply

How to add the MCB 105 option:

- The power to the adjustable frequency drive must be disconnected.
- The power to the live part connections on relay terminals must be disconnected.
- Remove the LCP, the terminal cover and the LCP fixture from the FC 30x.
- Fit the MCB 105 option in slot B.
- Connect the control cables and fasten them with the enclosed cable strips.
- Make sure the length of the stripped wire is correct (see the following drawing).
- Do not mix live parts (high voltage) with control signals (PELV).
- Fit the enlarged LCP fixture and enlarged terminal cover.
- Replace the LCP.
- Connect power to the adjustable frequency drive.
- Select the relay functions in par. 5-40 [6-8], 5-41 [6-8] and 5-42 [6-8].

NB (Array [6] is relay 7, array [7] is relay 8, and array [8] is relay 9)

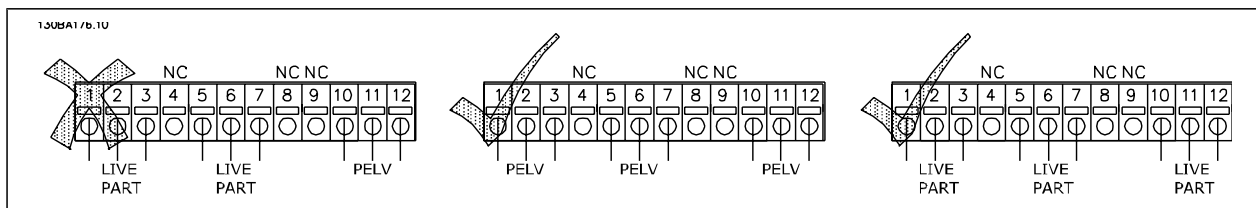
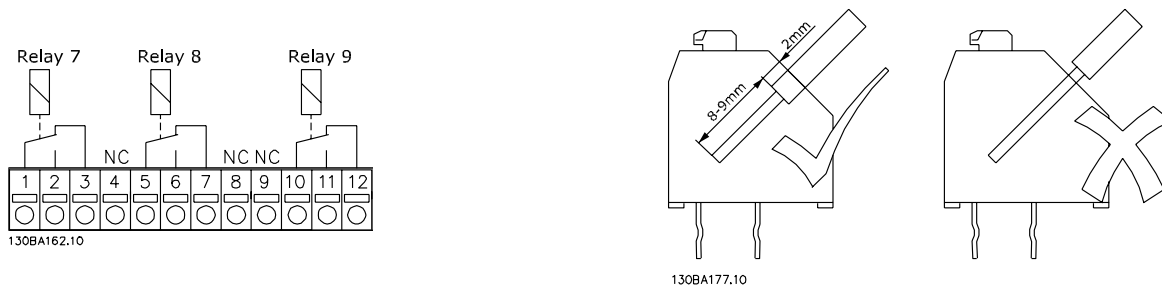

Do not combine 24/ 48 V systems with high voltage systems.

**□ 24 V Backup Option MCB 107 (Option D)**

External 24 V DC Supply

An external 24 V DC supply can be installed for low-voltage supply to the control card and any option card installed. This enables full operation of the LCP (including the parameter setting) without connection to line.

External 24 V DC supply specification:

Input voltage range 24 V DC ±15 % (max. 37 V in 10 s)

— Options and Accessories —

Max. input current	2.2 A
Average input current for FC 302	0.9 A
Max. cable length	246 ft [75 m]
Input capacitance load	< 10 $\mu$ F
Power-up delay	< 0.6 s

The inputs are protected.

Terminal numbers:

Terminal 35: - external 24 V DC supply.

Terminal 36: + external 24 V DC supply.

Follow these steps:

1. Remove the LCP or blind cover.
2. Remove the terminal cover.
3. Remove the cable decoupling plate and the plastic cover underneath.
4. Insert the 24 V DC backup external supply option in the option slot.
5. Mount the cable decoupling plate.
6. Attach the terminal cover and the LCP or blind cover.

When MCB 107, 24 V backup option is supplying the control circuit, the internal 24 V supply is automatically disconnected.

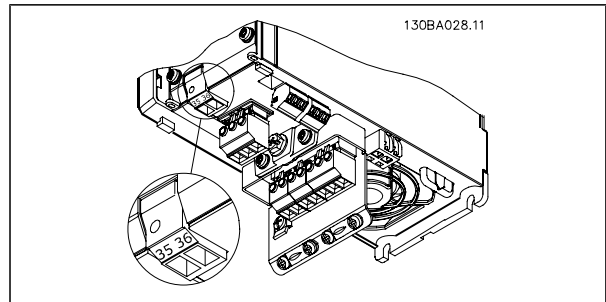

Connection to 24 V backup supply on frame sizes A2 and A3.

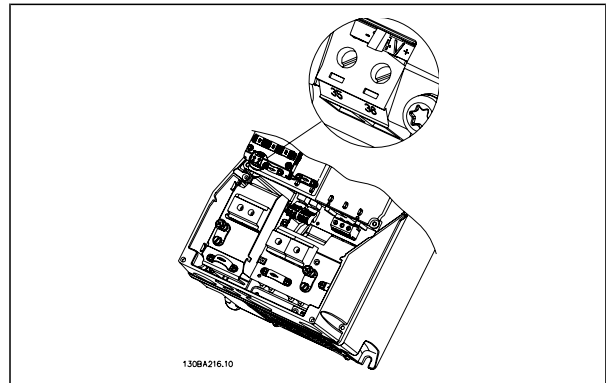

Connection to 24 V backup supply on frame sizes A5, B1, B2, C1 and C2.

### □ Brake Resistors

In applications where the motor is used as a brake, energy is generated in the motor and send back into the adjustable frequency drive. If the energy cannot be transported back to the motor, it will increase the voltage in the drive DC line. In applications with frequent braking and/or high inertia loads, this increase may lead to an overvoltage trip in the drive and finally a shut down. Brake resistors are used to dissipate the excess energy resulting from the regenerative braking. The resistor is selected in respect to its ohmic value, its power dissipation rate and its physical size. Danfoss offers a wide verity of different resistors that are specially designed to our drive code numbers and can be found in section *How to order*.

### □ Remote mounting Kit for LCP

The Local Control Panel can be moved to the front of a cabinet by using the remote build-in kit. The enclosure is the IP 65. The fastening screws must be tightened with a torque of max. 1 Nm.

Technical data	
Enclosure:	IP 65 front
Max. cable length between VLT and unit:	9.8 ft (3 m)
Communication std:	RS-485

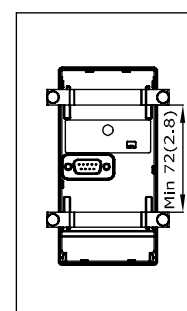
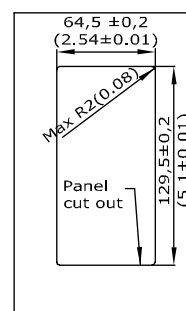
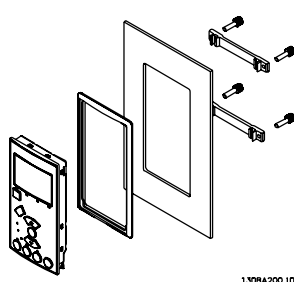
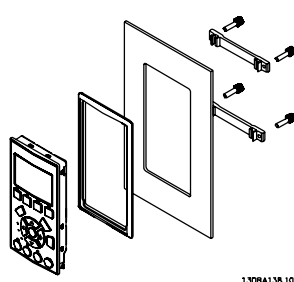

130BA139.11

### □ IP 21/IP 4X/ TYPE 1 (NEMA 1) Enclosure Kit

IP 20/IP 4X top/ TYPE 1 (NEMA 1) is an optional enclosure element available for IP 20 Compact units. If the enclosure kit is used, an IP 20 unit is upgraded to comply with enclosure IP 21/ 4X top/TYPER 1 (NEMA 1).

The IP 4X top can be applied to all standard IP 20 FC 30X variants.

□ **IP 21/Type 1 Enclosure Kit**

- A – Top cover
- B – Brim
- C – Base part
- D – Base cover
- E – Screw(s)

Place the top cover as shown. If an A or B option is used, the brim must be fitted to cover the top inlet. Place the base part C at the bottom of the drive and use the clamps from the accessory bag to correctly fasten the cables. Holes for cable glands:

Size A2: 2x M25 and 3xM32  
 Size A3: 3xM25 and 3xM32

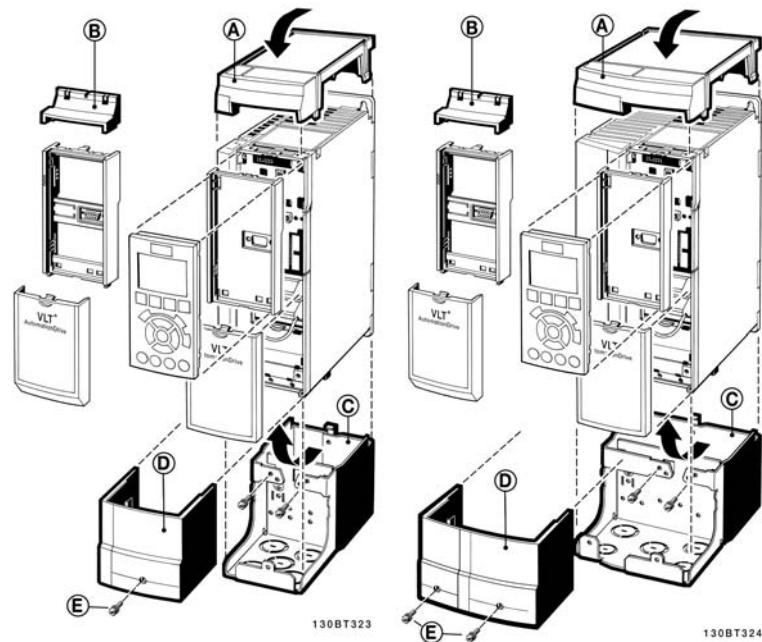

□ **Sine-wave Filters**

When a motor is controlled by an adjustable frequency drive, resonance noise will be heard from the motor. This noise, which is the result of the design of the motor, arises every time an inverter switch in the adjustable frequency drive is activated. The frequency of the resonance noise thus corresponds to the switching frequency of the adjustable frequency drive.

For the FC 300 Series, Danfoss can supply a sine-wave filter to dampen the acoustic motor noise.

The filter reduces the ramp-up time of the voltage, the peak load voltage  $U_{PEAK}$  and the ripple current  $\Delta I$  to the motor, which means that current and voltage become almost sinusoidal. The acoustic motor noise is thus reduced to a minimum.

The ripple current in the sine-wave filter coils will also cause some noise. Solve the problem by integrating the filter in a cabinet or the like.





## RS-485 Installation and Set-up



### □ RS-485 Installation and Set-up

#### □ Overview

RS-485 is a two-wire bus interface compatible with multi-drop network topology, i.e., nodes can be connected as a bus, or via drop cables from a common trunk line. A total of 32 nodes can be connected to one network segment.

Network segments are divided up by repeaters. Please note that each repeater functions as a node within the segment in which it is installed. Each node connected within a given network must have a unique node address across all segments.

Terminate each segment at both ends using either the termination switch (S801) of the adjustable frequency drives or a biased termination resistor network. Always use shielded twisted pair (STP) cable for bus cabling, and always follow good common installation practice.

Low-impedance ground connection of the shield at every node is very important, also at high frequencies. This can be achieved by connecting a large surface of the shield to ground, by means of a cable clamp or a conductive cable gland, for example. It may be necessary to apply potential-equalizing cables to maintain the same ground potential throughout the network, particularly in installations where there are long lengths of cable.

To prevent impedance mismatch, always use the same type of cable throughout the entire network. When connecting a motor to the adjustable frequency drive, always use shielded motor cable.

Cable: Shielded twisted pair (STP)

Impedance: 120 Ohm

Cable length: Max. 3,396 ft [1,200 m] (including drop lines)

Max. 1,640 ft [500 m] station-to-station

#### □ Network Connection

Connect the adjustable frequency drive to the RS-485 network as follows (see also diagram):

— RS-485 Installation and Set-up —

1. Connect signal wires to terminal 68 (P+) and terminal 69 (N-) on the main control board of the adjustable frequency drive.
2. Connect the cable shield to the cable clamps.



**NOTE**

Shielded, twisted-pair cables are recommended in order to reduce noise between conductors.

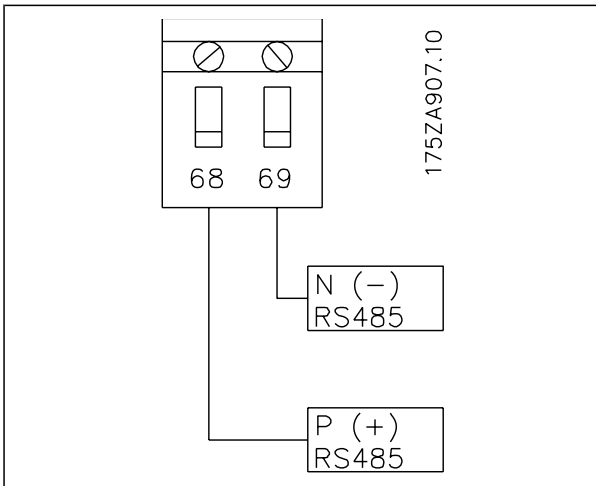

Network Terminal Connection

□ **FC 300 Hardware Setup**

Use the terminator dip switch on the main control board of the adjustable frequency drive to terminate the RS-485 bus.



**NOTE**

The factory setting for the dip switch is OFF.

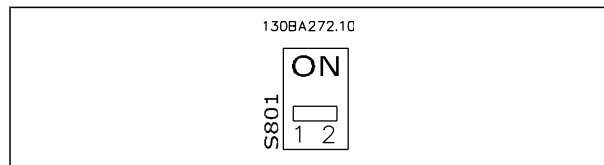

Terminator Switch Factory Setting

### □ FC 300 Parameter Settings for Modbus Communication

The following parameters apply to the RS-485 interface (FC-port):

Parameter Number	Parameter name	Function
8-30	Protocol	Select the application protocol to run on the RS-485 interface
8-31	Address	Set the node address. Note: The address range depends on the protocol selected in par. 8-30
8-32	Baud Rate	Set the baud rate. Note: The default baud rate depends on the protocol selected in par. 8-30
8-33	PC port parity/Stop bits	Set the parity and number of stop bits. Note: The default selection depends on the protocol selected in par. 8-30
8-35	Min. response delay	Specify a minimum delay time between receiving a request and transmitting a response. This can be used for overcoming modem turnaround delays.
8-36	Max. response delay	Specify a maximum delay time between transmitting a request and receiving a response.
8-37	Max. inter-char delay	Specify a maximum delay time between two received bytes to ensure timeout if transmission is interrupted.



### □ EMC Precautions

The following EMC precautions are recommended in order to achieve interference-free operation of the RS-485 network.



#### NOTE

Relevant national and local regulations regarding protective ground connection (e.g.) must be observed. The RS-485 communication cable must be kept away from motor and brake resistor cables to avoid coupling of high frequency noise from one cable to another. Normally a distance of 200 mm (8 inches) is sufficient, but keeping the greatest possible distance between the cables is generally recommended, especially where cables run in parallel over long distances. When crossing is unavoidable, the RS-485 cable must cross motor and brake resistor cables at an angle of 90 degrees.

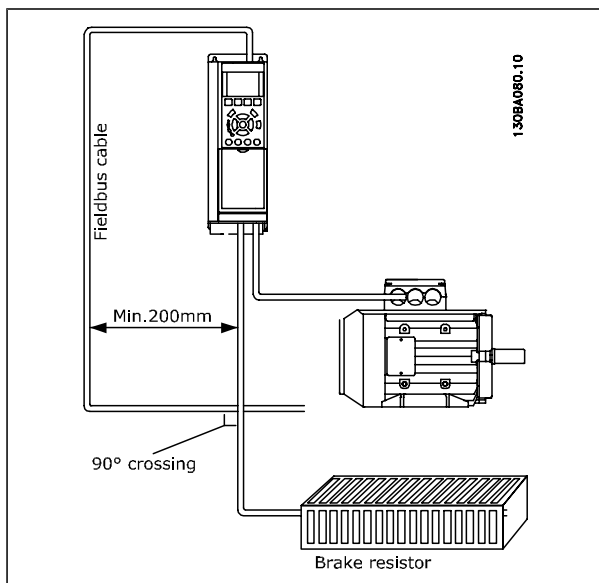

The FC protocol, also referred to as FC bus or Standard bus, is the Danfoss Drives standard serial communication bus. It defines an access technique according to the master-slave principle for communications via a serial bus.

One master and a maximum of 126 slaves can be connected to the bus. The individual slaves are selected by the master via an address character in the telegram. A slave itself can never transmit without first being requested to do so, and direct message transfer between the individual slaves is not possible. Communications occur in the half-duplex mode.

The master function cannot be transferred to another node (single-master system).

The physical layer is RS-485, thus utilizing the RS-485 port built into the adjustable frequency drive. The FC protocol supports different telegram formats; a short format of 8 bytes for process data, and a long format of 16 bytes that also includes a parameter channel. A third telegram format is used for texts.

## ▣ Network Configuration

### ▣ FC 300 Adjustable Frequency Drive Set-up

Set the following parameters to enable the FC protocol for the FC 300.

Parameter Number	Parameter name	Setting
8-30	Protocol	FC
8-31	Address	1 - 126
8-32	Baud Rate	2400 - 115200
8-33	Parity/Stop bits	Even parity, 1 stop bit (default)

## □ FC Protocol Message Framing Structure - FC 300

### □ Content of a Character (byte)

Each character transferred begins with a start bit. Then 8 data bits are transferred, corresponding to a byte. Each character is secured via a parity bit, which is set at "1" when it reaches parity (i.e., when there is an equal number of 1's in the 8 data bits and the parity bit in total). A character is completed by a stop bit, thus consisting of 11 bits in all.

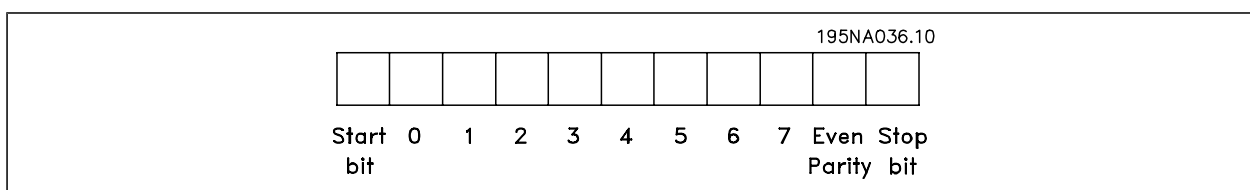

### □ Message Structure

Each telegram begins with a start character (STX)=02 Hex, followed by a byte denoting the message length (LGE) and a byte denoting the adjustable frequency drive address (ADR). A number of data bytes (variable, depending on the type of telegram) follows. The telegram is completed by a data control byte (BCC).

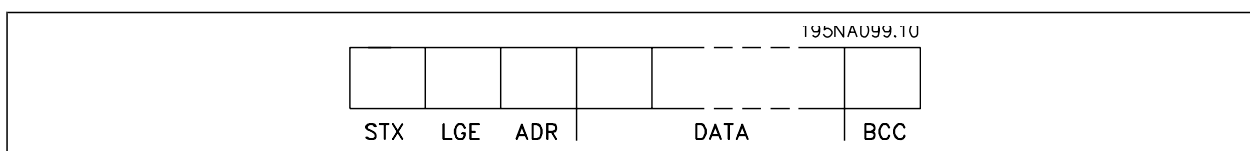

### □ Message Length (LGE)

The message length is the number of data bytes plus the address byte ADR and the data control byte BCC.

The length of telegrams with 4 data bytes is LGE = 4 + 1 + 1 = 6 bytes

The length of telegrams with 12 data bytes is LGE = 12 + 1 + 1 = 14 bytes

The length of telegrams containing texts is  $10^1 + n$  bytes

<sup>1)</sup> The 10 represents the fixed characters, while the "n" is variable (depending on the length of the text).

### □ Adjustable Frequency Drive Address (ADR)

Two different address formats are used.

The address range of the adjustable frequency drive is either 1-31 or 1-126.

1. Address format 1-31:

Bit 7 = 0 (address format 1-31 active)

Bit 6 is not used

Bit 5 = 1: Broadcast, address bits (0-4) are not used

Bit 5 = 0: No Broadcast

Bit 0-4 = Adjustable frequency drive address 1-31

2. Address format 1-126:

Bit 7 = 1 (address format 1-126 active)

Bit 0-6 = Adjustable frequency drive address 1-126

Bit 0-6 = 0 Broadcast

The slave returns the address byte unchanged to the master in the response telegram.

□ **Data Control Byte (BCC)**

The checksum is calculated as an XOR-function. Before the first byte in the telegram is received, the calculated checksum is 0.

□ **The Data Field**

The structure of data blocks depends on the type of telegram. There are three telegram types, and the type applies for both control telegrams (master=>slave) and response telegrams (slave=>master).

The three types of telegram are:

Process block (PCD):

The PCD is made up of a data block of four bytes (2 words) and contains:

- Control word and reference value (from master to slave)
- Status word and present output frequency (from slave to master).

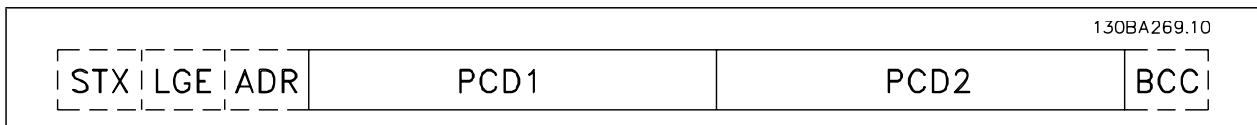

Parameter block:

The parameter block is used to transfer parameters between master and slave. The data block is made up of 12 bytes (6 words) and also contains the process block.

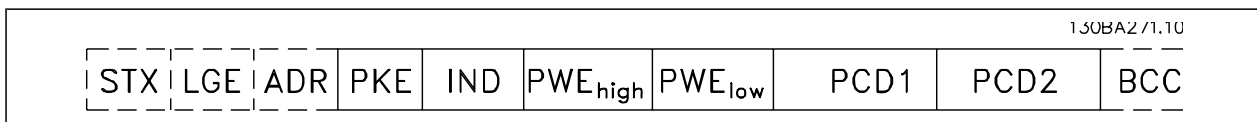

Text block:

The text block is used to read or write texts via the data block.

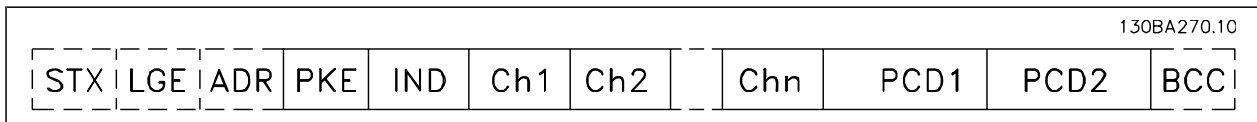

□ **The PKE Field**

The PKE field contains two sub-fields: Parameter command and response AK, and parameter number PNU:

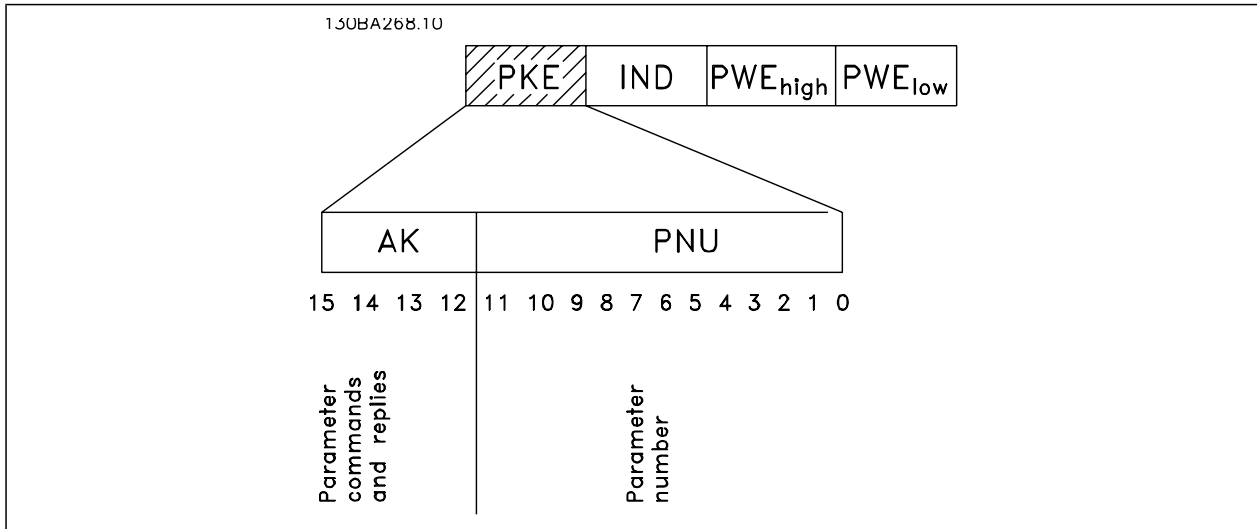

Bits no. 12-15 transfer parameter commands from master to slave and return processed slave responses to the master.

Parameter commands master ⇒ slave				
Bit no.	Parameter command			
15	14	13	12	
0	0	0	0	No command
0	0	0	1	Read parameter value
0	0	1	0	Write parameter value in RAM (word)
0	0	1	1	Write parameter value in RAM (double word)
1	1	0	1	Write parameter value in RAM and EEPROM (double word)
1	1	1	0	Write parameter value in RAM and EEPROM (word)
1	1	1	1	Read/write text

Response slave ⇒ master				
Bit no.	Response			
15	14	13	12	
0	0	0	0	No response
0	0	0	1	Parameter value transferred (word)
0	0	1	0	Parameter value transferred (double word)
0	1	1	1	Command cannot be performed
1	1	1	1	text transferred

If the command cannot be performed, the slave sends this response:

*0111 Command cannot be performed*

- and issues the following fault report in the parameter value (PWE):

PWE low (Hex)	Fault Report
0	The parameter number used does not exist.
1	There is no write access to the defined parameter.
2	Data value exceeds the parameter's limits.
3	The sub index used does not exist.
4	The parameter is not the array type.
5	The data type does not match the defined parameter.
11	Data change in the defined parameter is not possible in the adjustable frequency drive's present mode. Certain parameters can only be changed when the motor is turned off.
82	There is no bus access to the defined parameter.
83	Data change is not possible because factory setup is selected.



#### □ Parameter Number (PNU)

Bits no. 0-11 transfer parameter numbers. The function of the relevant parameter is defined in the parameter description in the chapter How to Program.

#### □ Index (IND)

The index is used together with the parameter number to read/write-access parameters with an index; e.g., par. 15-30 *Error Code*. The index consists of 2 bytes, a low byte and a high byte.



#### NOTE

Only the low byte is used as an index.

#### □ Parameter Value (PWE)

The parameter value block consists of 2 words (4 bytes), and the value depends on the defined command (AK). The master prompts for a parameter value when the PWE block contains no value. To change a parameter value (write), write the new value in the PWE block and send from the master to the slave.

When a slave responds to a parameter request (read command), the present parameter value in the PWE block is transferred and returned to the master. If a parameter contains not a numerical value but several data options, such as par. 0-01 Language where [0] corresponds to English, and [4] corresponds to Danish, select the data value by entering the value in the PWE block. See Example - Selecting a data value. Serial communication is only capable of reading parameters containing data type 9 (text string).

Parameters 15-40 to 15-53 contain data type 9.

For example, read the unit size and line voltage range in par. 15-40 *FC Type*. When a text string is transferred (read), the length of the telegram is variable, and the texts are of different lengths. The message length is defined in the second byte of the telegram, LGE. When using text transfer the index character indicates whether it is a read or a write command.

To read a text via the PWE block, set the parameter command (AK) to 'F' Hex. The index character high-byte must be "4".

Some parameters contain text that can be written to via the serial bus. To write a text via the PWE block, set the parameter command (AK) to 'F' Hex. The index characters high-byte must be "5".



	PKE	IND	PWE <sub>high</sub>	PWE <sub>low</sub>
Read text	Fx xx	04 00		
Write text	Fx xx	05 00		

130BA275.11

□ **Data Types Supported by FC 300**

Unsigned means that there is no operational sign in the telegram.

Data types	Description
3	Integer 16
4	Integer 32
5	Unsigned 8
6	Unsigned 16
7	Unsigned 32
9	Text string
10	Byte string
13	Time difference
33	Reserved
35	Bit sequence

□ **Conversion**

The various attributes of each parameter are displayed in the section entitled "Factory Settings." Parameter values are transferred as whole numbers only. Conversion factors are therefore used to transfer decimals.

Par. 4-12 *Motor Speed, Low Limit* has a conversion factor of 0.1.

To preset the minimum frequency to 10 Hz, transfer the value 100. A conversion factor of 0.1 means that the value transferred is multiplied by 0.1. The value 100 is thus perceived as 10.0.

Conversion table	
Conversion index	Conversion factor
74	0.1
2	100
1	10
0	1
-1	0.1
-2	0.01
-3	0.001
-4	0.0001
-5	0.00001

**□ Process Words (PCD)**

The block of process words is divided into two blocks of 16 bits, which always occur in the defined sequence.

PCD 1	PCD 2
Control telegram (master⇒ Control word slave)	Reference value
Control telegram (slave ⇒master) Status word	Present output frequency

**□ Examples**

**□ Writing a parameter value**

Change par. 4-14 *Motor Speed High Limit [Hz]* to 100 Hz.  
Write the data in EEPROM.

PKE = E19E Hex - Write single word in par. 4-14 *Motor Speed High Limit [Hz]*  
IND = 0000 Hex  
PWEHIGH = 0000 Hex  
PWELOW = 03E8 Hex - Data value 1000, corresponding to 100 Hz, see Conversion.

The telegram will look like this:

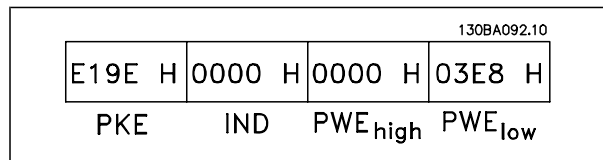

Note: Parameter 4-14 is a single word, and the parameter command for write in EEPROM is "E". Parameter number 414 is 19E in hexadecimal.

The response from the slave to the master will be:

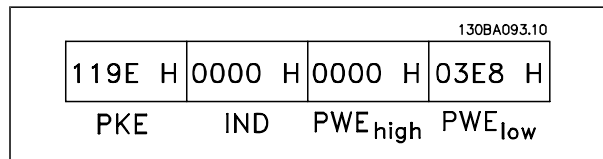

**□ Reading a parameter value**

Read the value in par. 3-41 *Ramp 1 Up Time*.

PKE = 1155 Hex - Read parameter value in par. 3-41 *Ramp 1 Up Time*  
IND = 0000 Hex  
PWEHIGH = 0000 Hex  
PWELOW = 0000 Hex

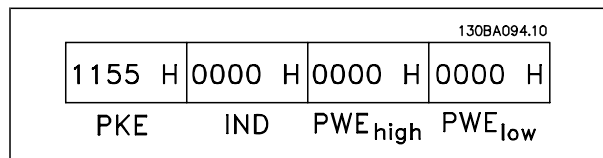

If the value in par. 3-41 *Ramp 1 Up Time* is 10 s, the response from the slave to the master will be:

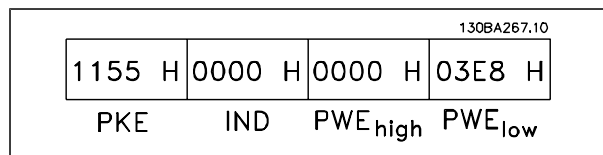

**NOTE**

3E8 Hex corresponds to 1000 decimal. The conversion index for par. 3-41 is -2, i.e., 0.01.

## □ Danfoss FC Control Profile

### □ Control Word According to FC Profile (Par. 8-10 = FC profile)

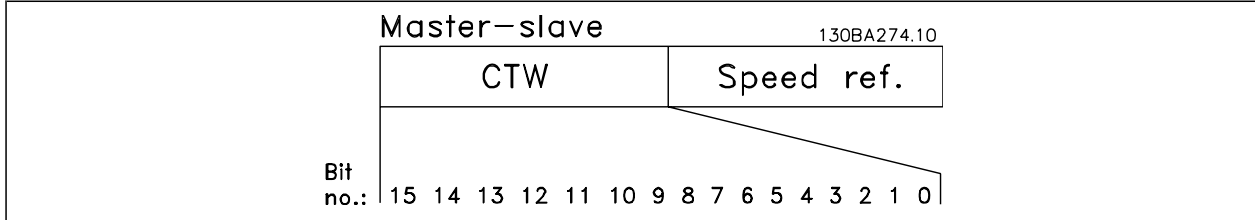

Bit	Bit value = 0	Bit value = 1
00	Reference value	external selection lsb
01	Reference value	external selection msb
02	DC brake	Ramp
03	Coasting	No coasting
04	Quick stop	Ramp
05	Hold output frequency	use ramp
06	Ramp stop	Start
07	No function	Reset
08	No function	Jog
09	Ramp 1	Ramp 2
10	Data invalid	Data valid
11	No function	Relay 01 active
12	No function	Relay 02 active
13	Parameter set-up	selection lsb
14	Parameter set-up	selection msb
15	No function	Reverse

### Explanation of the Control Bits

#### Bits 00/01

Bits 00 and 01 are used to choose between the four reference values, which are pre-programmed in par. 3-10 *Preset reference* according to the following table:

Programmed ref. value	Par.	Bit 01	Bit 00
1	3-10 [0]	0	0
2	3-10 [1]	0	1
3	3-10 [2]	1	0
4	3-10 [3]	1	1



#### NOTE

Make a selection in par. 8-56 *Preset Reference Select* to define how Bit 00/01 gates with the corresponding function on the digital inputs.

#### Bit 02, DC brake:

Bit 02 = '0' leads to DC braking and stop. Set braking current and duration in par. 2-01 *DC Brake Current* and 2-02 *DC Braking Time* . Bit 02 = '1' leads to ramping.

#### Bit 03, Coasting:

Bit 03 = '0': The adjustable frequency drive immediately "lets go" of the motor, (the output transistors are "shut off") and it coasts to a standstill. Bit 03 = '1': The adjustable frequency drive starts the motor if the other starting conditions are met.

**NOTE**

Make a selection in par. 8-50 *Coasting Select* to define how Bit 03 gates with the corresponding function on a digital input.

Bit 04, Quick stop:

Bit 04 = '0': Makes the motor speed ramp down to stop (set in par. 3-81 *Quick Stop Ramp Time*).

Bit 05, Hold output frequency

Bit 05 = '0': The present output frequency (in Hz) freezes. Change the frozen output frequency only by means of the digital inputs (par. 5-10 to 5-15) programmed to *Speed up* and *Slow down*.

**NOTE**

If freeze output is active, the adjustable frequency drive can only be stopped by the following:

- Bit 03 Coasting stop
- Bit 02 DC braking
- Digital input (par. 5-10 to 5-15) programmed to *DC braking*, *Coasting stop*, or *Reset and coasting stop*.

Bit 06, Ramp stop/start:

Bit 06 = '0': Causes a stop and makes the motor speed ramp down to stop via the selected ramp down par. Bit 06 = '1': Permits the adjustable frequency drive to start the motor if the other starting conditions are met.

**NOTE**

Digital input (par. 5-10 to 5-15) programmed to *DC braking*, *Coasting stop*, or *Reset and coasting stop*.

Bit 07, Reset: Bit 07 = '0': No reset. Bit 07 = '1': Resets a trip. Reset is activated on the leading edge of the signal, i.e., when changing from logic '0' to logic '1'.

Bit 08, Jog:

Bit 08 = '1': The output frequency is determined by par. 3-19 *Jog Speed*.

Bit 09, Selection of ramp 1/2:

Bit 09 = "0": Ramp 1 is active (par. 3-40 to 3-47). Bit 09 = "1": Ramp 2 (par. 3-50 to 3-57) is active.

Bit 10, Data not valid/Data valid:

Tell the adjustable frequency drive whether to use or ignore the control word. Bit 10 = '0': The control word is ignored. Bit 10 = '1': The control word is used. This function is relevant because the telegram always contains the control word, regardless of the telegram type. Thus, you can turn off the control word if you do not want to use it when updating or reading parameters.

Bit 11, Relay 01:

Bit 11 = "0": Relay not activated. Bit 11 = "1": Relay 01 activated provided that *Control word bit 11* is chosen in par. 5-40 *Function relay*.

Bit 12, Relay 04:

Bit 12 = "0": Relay 04 is not activated. Bit 12 = "1": Relay 04 is activated provided that *Control word bit 12* is chosen in par. 5-40 *Function relay*.

Bit 13/14, Selection of set-up:

Use bits 13 and 14 to choose from the four menu set-ups according to the shown table:

— RS-485 Installation and Set-up —

Set-up	Bit 14	Bit 13
1	0	0
2	0	1
3	1	0
4	1	1

The function is only possible when *Multi Set-ups* is selected in par. 0-10 *Active Set-up*



**NOTE**

Make a selection in par. 8-55 *Set-up select* to define how Bit 13/14 gates with the corresponding function on the digital inputs.

Bit 15 Reverse:

Bit 15 = '0': No reversing. Bit 15 = '1': Reversing. In the default setting, reversing is set to digital in par. 8-54 *Reversing Select*. Bit 15 causes reversing only when ser. communication, 'Logic or' or 'Logic and' is selected.

□ **Status Word According to FC Profile (STW) (Par. 8-10 = FC profile)**

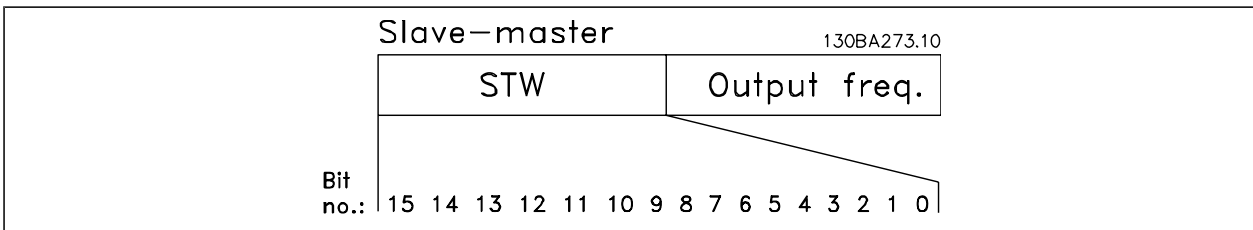

Bit	Bit = 0	Bit = 1
00	Control not ready	Control ready
01	Drive not ready	Drive ready
02	Coasting	Enable
03	No error	Trip
04	No error	Error (no trip)
05	Reserved	-
06	No error	Triplock
07	No warning	Warning
08	Speed ≠ reference	Speed = reference
09	Local operation	Bus control
10	Out of frequency limit	Frequency limit OK
11	No operation	In operation
12	Drive OK	Stopped, auto start
13	Voltage OK	Voltage exceeded
14	Torque OK	Torque exceeded
15	Timer OK	Timer exceeded

**Explanation of the Status Bits**

Bit 00, Control not ready/ready:

Bit 00 = '0': The adj. frequency drive trips. Bit 00 = '1': The adjustable frequency drive controls are ready, but the power component does not necessarily receive any power supply (in case of external 24 V supply to controls).

Bit 01, Drive ready:

Bit 01 = '1': The adjustable frequency drive is ready for operation, but the coasting command is active via the digital inputs or via serial communication.

Bit 02, Coasting stop:

Bit 02 = '0': The adjustable frequency drive releases the motor. Bit 02 = '1': The adjustable frequency drive starts the motor with a start command.

Bit 03, No error/trip:

Bit 03 = '0': The adjustable frequency drive is not in fault mode. Bit 03 = '1': The adjustable frequency drive trips. To re-establish operation, enter [Reset].

Bit 04, No error/error (no trip):

Bit 04 = '0': The adjustable frequency drive is not in fault mode. Bit 04 = "1": The adjustable frequency drive shows an error but does not trip.

Bit 05, Not used:

Bit 05 is not used in the status word.

Bit 06, No error / triplock:

Bit 06 = '0': The adjustable frequency drive is not in fault mode. Bit 06 = "1": The adjustable frequency drive is tripped and locked.

Bit 07, No warning/warning:

Bit 07 = '0': There are no warnings. Bit 07 = '1': A warning has occurred.

Bit 08, Speed≠ reference/speed = reference:

Bit 08 = '0': The motor is running but the present speed is different from the preset speed reference. For example, this might be the case when the speed ramps up/down during start/stop. Bit 08 = '1': The motor speed matches the preset speed reference.

Bit 09, Local operation/bus control:

Bit 09 = '0': [STOP/RESET] is activated on the control unit, or *Local control* in par. 3-13 *Reference Site* is selected. You cannot control the adjustable frequency drive via serial communication. Bit 09 = '1' It is possible to control the adjustable frequency drive via serial communication or the serial communication bus.

Bit 10, Out of frequency limit:

Bit 10 = '0': The output frequency has reached the value in par. 4-11 *Motor Speed Low Limit* or par. 4-13 *Motor Speed High Limit*. Bit 10 = "1": The output frequency is within the defined limits.

Bit 11, No operation/in operation:

Bit 11 = '0': The motor is not running. Bit 11 = '1': The adjustable frequency drive has a start signal, or the output frequency is greater than 0 Hz.

Bit 12, Drive OK/stopped, autostart:

Bit 12 = '0': There is no temporary overtemperature on the inverter. Bit 12 = '1': The inverter stops because of overtemperature, but the unit does not trip and will resume operation once the overtemperature stops.

Bit 13, Voltage OK/limit exceeded:

Bit 13 = '0': There are no voltage warnings. Bit 13 = '1': The DC voltage in the intermediate circuit of the adjustable frequency drive is too low or too high.

Bit 14, Torque OK/limit exceeded:

Bit 14 = '0': The motor current is lower than the torque limit selected in par. 4-18 *Current Limit*. Bit 14 = '1': The torque limit in par. 4-18 *Current Limit* is exceeded.

Bit 15, Timer OK/limit exceeded:

Bit 15 = '0': The timers for motor thermal protection and VLT thermal protection are not exceeded 100%. Bit 15 = '1': One of the timers exceeds 100%.



**NOTE**

All bits in the STW are set to '0' if the connection between the Interbus option and the adjustable frequency drive is lost, or if an internal communication problem has occurred.

□ **Bus Speed Reference Value**

Speed reference value is transmitted to the adjustable frequency driver in a relative value in %. The value is transmitted in the form of a 16-bit word; in integers (0-32767) the value 16384 (4000 Hex) corresponds to 100%. Negative figures are formatted by means of 2's complement. The Actual Output frequency (MAV) is scaled in the same way as the bus reference.

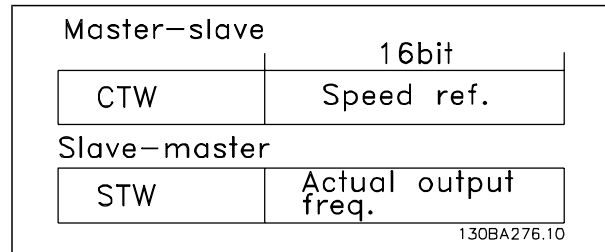

The reference and MAV are scaled as follows:

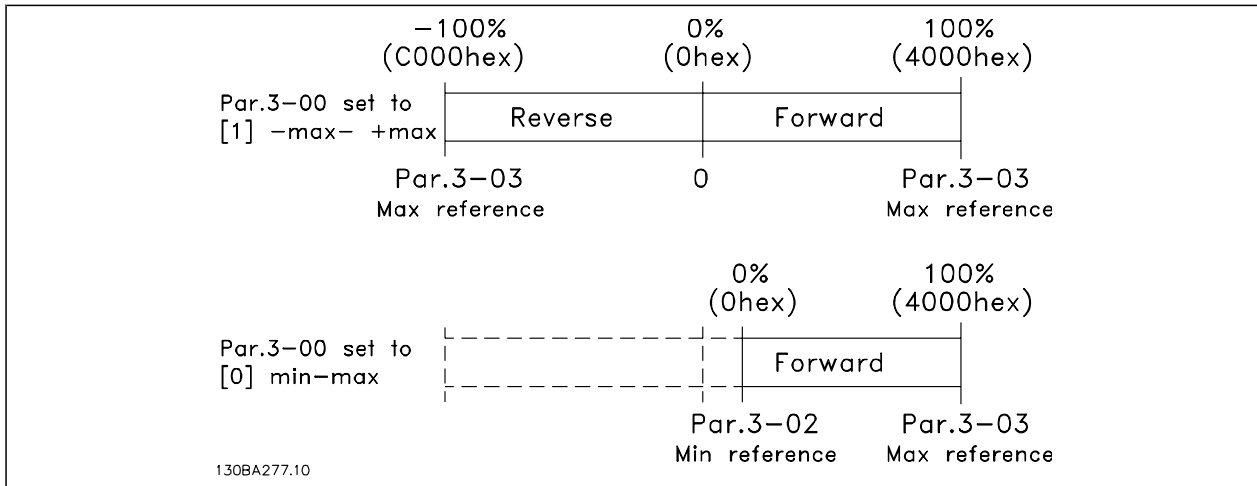

□ **PROFIdrive Control Profile**

This section describes the functionality of the control word and status word in the PROFIdrive profile. Select this profile by setting par. 8-10 *Control word profile to PROFIdrive*.

□ **Control Word according to PROFIdrive Profile (CTW)**

The control word is used to send commands from a master (a PC, for example) to a slave.

Bit	Bit = 0	Bit = 1
00	OFF 1	ON 1
01	OFF 2	ON 2
02	OFF 3	ON 3
03	Coasting	No coasting
04	Quick stop	Ramp
05	Hold frequency output	Use ramp
06	Ramp stop	Start
07	No function	Reset
08	Jog 1 OFF	Jog 1 ON
09	Jog 2 OFF	Jog 2 ON
10	Data invalid	Data valid
11	No function	Slow-down
12	No function	Catch up
13	Parameter set-up	Selection lsb
14	Parameter set-up	Selection msb
15	No function	Reverse

### Explanation of the Control Bits

#### Bit 00, OFF 1/ON 1

Normal ramp using the ramp times of the actual selected ramp.

Bit 00 = "0" leads to the stop and activation of the output relay 1 or 2 if the output frequency is 0 Hz, and if [Relay 123] has been selected in par. 5-40 *Function relay*.

When bit 00 = "1", the adjustable frequency drive is in state 1: "Switching on inhibited".

Please refer to the PROFIdrive State Transition Diagram at the end of this section.

#### Bit 01, OFF 2/ON 2

Coasting stop

When bit 01 = "0", a coasting stop and activation of the output relay 1 or 2 occurs if the output frequency is 0 Hz and if [Relay 123] has been selected in par. 5-40 *Function relay*.

When bit 01 = "1", the adjustable frequency drive is in state 1: "Switching on inhibited". Please refer to the PROFIdrive State Transition Diagram at the end of this section.

#### Bit 02, OFF 3/ON 3

Quick stop using the ramp time of par. 3-81 *Quick stop ramp time*. When bit 02 = "0", a quick stop and activation of the output relay 1 or 2 occurs if the output frequency is 0 Hz, and if [Relay 123] has been selected in par. 5-40 *Function relay*.

When bit 02 = "1", the adjustable frequency drive is in state 1: "Switching on inhibited".

Please refer to the PROFIdrive State Transition Diagram at the end of this section.

#### Bit 03, Coasting/No coasting

Coasting stop bit 03 = "0" leads to a stop. When bit 03 = "1", the adjustable frequency drive can start if the other start conditions are satisfied.



#### **NOTE**

The selection in par. 8-50 Coasting select determines how bit 03 is linked with the corresponding function of the digital inputs.

#### Bit 04, Quick stop/Ramp

Quick stop using the ramp time of par. 3-81 *Quick stop ramp time*.

When bit 04 = "0", a quick stop occurs.



When bit 04 = "1", the adjustable frequency drive can start if the other start conditions are satisfied.

**NOTE**

The selection in par. 8-51 *Quick stop select* determines how bit 04 is linked with the corresponding function of the digital inputs.

**Bit 05, Hold frequency output/Use ramp**

When bit 05 = "0", the current output frequency is maintained even if the reference value is modified. When bit 05 = "1", the adjustable frequency drive can perform its regulating function again; operation occurs according to the respective reference value.

**Bit 06, Ramp stop/Start**

Normal ramp stop using the ramp times of the actual ramp as selected. In addition, activation of the output relay 01 or 04 if the output frequency is 0 Hz if Relay 123 has been selected in par. 5-40 *Function relay*. Bit 06 = "0" leads to a stop. When bit 06 = "1", the adjustable frequency drive can start if the other start conditions are satisfied.

**NOTE**

The selection in par. 8-53 *Start select* determines how bit 06 is linked with the corresponding function of the digital inputs.

**Bit 07, No function/Reset**

Reset after switching off.

Acknowledges event in fault buffer.

When bit 07 = "0", no reset occurs.

When there is a slope change of bit 07 to "1", a reset occurs after switching off.

**Bit 08, Jog 1 OFF/ON**

Activation of the pre-programmed speed in par. 8-90 *Bus Jog 1 speed*. Jog 1 is only possible if bit 04 = "0" and bit 00 - 03 = "1".

**Bit 09, Jog 2 OFF/ON**

Activation of the pre-programmed speed in par. 8-91 *Bus Jog 2 speed*. Jog 2 is only possible if bit 04 = "0" and bit 00 - 03 = "1".

**Bit 10, Data invalid/valid**

Is used to tell the adjustable frequency drive whether the control word is to be used or ignored. Bit 10 = "0" causes the control word to be ignored, Bit 10 = "1" causes the control word to be used. This function is relevant, because the control word is always contained in the telegram, regardless of which type of telegram is used, i.e., it is possible to turn off the control word if you do not wish to use it in connection with updating or reading parameters.

**Bit 11, No function/Slow-down**

Is used to reduce the speed reference value by the amount given in par. 3-12 *Catch up/slow-down value*. When bit 11 = "0", no modification of the reference value occurs. When bit 11 = "1", the reference value is reduced.

**Bit 12, No function/Catch up**

Is used to increase the speed reference value by the amount given in par. 3-12 *Catch up/slow-down value*.

When bit 12 = "0", no modification of the reference value occurs.

When bit 12 = "1", the reference value is increased.

If both - slowing down and accelerating - are activated (bit 11 and 12 = "1"), slowing down has priority, i.e., the speed reference value will be reduced.



Bits 13/14, Set-up selection

Bits 13 and 14 are used to choose between the four parameter set-ups according to the following table:

The function is only possible if *Multi Set-up* has been chosen in par. 0-10 Active set-up. The selection in par. 8-55 *Set-up select* determines how bits 13 and 14 are linked with the corresponding function of the digital inputs. Changing set-up while running is only possible if the set-ups have been linked in par. 0-12 *This set-up linked to*.

Set-up	Bit 13	Bit 14
1	0	0
2	1	0
3	0	1
4	1	1

Bit 15, No function/Reverse

Bit 15 = "0" causes no reversing.

Bit 15 = "1" causes reversing.

Note: In the factory setting reversing is set to *digital* in par. 8-54 *Reversing select*.



**NOTE**

Bit 15 causes reversing only when *Ser. communication, Logic or - or - Logic and* is selected.

□ **Status Word according to PROFIdrive Profile (STW)**

The status word is used to notify a master (a PC, e.g.) about the status of a slave.

Bit	Bit = 0	Bit = 1
00	Control not ready	Control ready
01	Drive not ready	Drive ready
02	Coasting	Enable
03	No error	Trip
04	OFF 2	ON 2
05	OFF 3	ON 3
06	Start possible	Start not possible
07	No warning	Warning
08	Speed ≠ reference	Speed = reference
09	Local operation	Bus control
10	Out of frequency limit	Frequency limit ok
11	No operation	In operation
12	Drive OK	Stopped, autostart
13	Voltage OK	Voltage exceeded
14	Torque OK	Torque exceeded
15	Timer OK	Timer exceeded

**Explanation of the Status Bits**

Bit 00, Control not ready/ready

When bit 00 = "0", bit 00, 01 or 02 of the control word is "0" (OFF 1, OFF 2 or OFF 3) - or the adjustable frequency drive is switched off (trip).

When bit 00 = "1", the adjustable frequency drive control is ready, but there is not necessarily power supply to the unit present (in the event of external 24 V supply of the control system).

Bit 01, VLT not ready/ready

Same significance as bit 00, however, there is a supply of the power unit. The adjustable frequency drive is ready when it receives the necessary start signals.

#### Bit 02, Coasting/Enable

When bit 02 = "0", bit 00, 01 or 02 of the control word is "0" (OFF 1, OFF 2 or OFF 3 or coasting) - or the adjustable frequency drive is switched off (trip).

When bit 02 = "1", bit 00, 01 or 02 of the control word is "1"; the adjustable frequency drive has not tripped.

#### Bit 03, No error/Trip

When bit 03 = "0", no error condition of the adjustable frequency drive exists.

When bit 03 = "1", the adjustable frequency drive has tripped and requires a reset signal before it can start.

#### Bit 04, ON 2/OFF 2

When bit 01 of the control word is "0", then bit 04 = "0".

When bit 01 of the control word is "1", then bit 04 = "1".

#### Bit 05, ON 3/OFF 3

When bit 02 of the control word is "0", then bit 05 = "0".

When bit 02 of the control word is "1", then bit 05 = "1".

#### Bit 06, Start possible/Start not possible

If PROFIdrive has been selected in par. 8-10 *Control word profile*, bit 06 will be "1" after a switch-off acknowledgement, after activation of OFF2 or OFF3, and after switching on the line voltage. Start not possible will be reset, with bit 00 of the control word being set to "0" and bit 01, 02 and 10 being set to "1".

#### Bit 07, No warning/Warning

Bit 07 = "0" means that there are no warnings.

Bit 07 = "1" means that a warning has occurred.

#### Bit 08, Speed ≠ reference / Speed = reference

When bit 08 = "0", the current speed of the motor deviates from the set speed reference value. This may occur, for example, when the speed is being changed during start/stop through ramp up/down.

When bit 08 = "1", the current speed of the motor corresponds to the set speed reference value.

#### Bit 09, Local operation/Bus control

Bit 09 = "0" indicates that the adjustable frequency drive has been stopped by means of the stop button on the control panel, or that [Linked to hand] or [Local] has been selected in par. 3-13 *Reference site*.

When bit 09 = "1", the adjustable frequency drive can be controlled through the serial interface.

#### Bit 10, Out of frequency limit/Frequency limit OK

When bit 10 = "0", the output frequency is outside the limits set in par. 4-11 *Motor speed low limit (rpm)* and par. 4-13 *Motor speed high limit (rpm)*. When bit 10 = "1", the output frequency is within the indicated limits.

#### Bit 11, No operation/Operation

When bit 11 = "0", the motor does not turn.

When bit 11 = "1", the adjustable frequency drive has a start signal, or the output frequency is higher than 0 Hz.

#### Bit 12, Drive OK/Stopped, autostart

When bit 12 = "0", there is no temporary overloading of the inverter.



When bit 12 = "1", the inverter has stopped due to overloading. However, the adjustable frequency drive has not switched off (trip) and will start again after the overloading has ended.

Bit 13, Voltage OK/Voltage exceeded

When bit 13 = "0", the voltage limits of the adjustable frequency drive are not exceeded.

When bit 13 = "1", the direct voltage in the intermediate circuit of the adjustable frequency drive is too low or too high.

Bit 14, Torque OK/Torque exceeded

When bit 14 = "0", the motor torque is below the limit selected in par. 4-16 *Torque limit motor mode* and par. 4-17 *Torque limit generator mode*. When bit 14 = "1", the limit selected in par. 4-16 *Torque limit motor mode* or par. 4-17 *Torque limit generator mode* is exceeded.

Bit 15, Timer OK/Timer exceeded

When bit 15 = "0", the timers for the thermal motor protection and thermal adjustable frequency drive protection have not exceeded 100%.

When bit 15 = "1", one of the timers has exceeded 100%.



## Troubleshooting



### □ Warnings/Alarm Messages

A warning or an alarm is signaled by the relevant LED on the front of the adjustable frequency drive and indicated by a code on the display.

A warning remains active until its cause is no longer present. Under certain circumstances, operation of the motor may still be continued. Warning messages may be critical, but are not necessarily so.

In the event of an alarm, the adjustable frequency drive will have tripped. Alarms must be reset to restart operation once their cause has been rectified. This may be done in three ways:

1. By using the [RESET] control button on the LCP control panel.
2. Via a digital input with the "Reset" function.
3. Via serial communication/optional serial communication bus.



#### NOTE

After a manual reset using the [RESET] button on the LCP, the [AUTO ON] button must be pressed to restart the motor.

If an alarm cannot be reset, the reason may be that its cause has not been rectified, or that the alarm is trip-locked (see also the table on following page).

Alarms that are trip-locked offer additional protection, meaning that the line supply must be switched off before the alarm can be reset. After being switched back on, the FC 300 is no longer blocked and may be reset as described above, once the cause has been rectified.

Alarms that are not trip-locked can also be reset using the automatic reset function in parameters 14-20 (Warning: automatic wake-up is possible!)

If a warning and alarm is marked against a code in the table on the following page, this means that either a warning occurs before an alarm, or that you can specify whether it is a warning or an alarm that is to be displayed for a given fault.



— Troubleshooting —

This is possible, for instance, in parameters 1-90 *Motor Thermal Protection*. After an alarm or trip, the motor carries on coasting, and the alarm and warning flash. Once the problem has been rectified, only the alarm continues flashing until the FC 300 is reset.

**Alarm/Warning code list**

No.	Description	Warning	Alarm/Trip	Alarm/Trip Lock	Parameter Reference
1	10 Volts low	X			
2	Live zero error	(X)	(X)		6-01
3	No motor	(X)			1-80
4	Line phase loss	(X)	(X)	(X)	14-12
5	DC link voltage high	X			
6	DC link voltage low	X			
7	DC overvoltage	X	X		
8	DC undervoltage	X	X		
9	Inverter overloaded	X	X		
10	Motor ETR overtemperature	(X)	(X)		1-90
11	Motor thermistor overtemperature	(X)	(X)		1-90
12	Torque limit	X	X		
13	Overcurrent	X	X	X	
14	Ground Fault	X	X	X	
15	Hardware mismatch		X	X	
16	Short Circuit		X	X	
17	Control word timeout	(X)	(X)		8-04
23	Internal Fan Fault	X			
24	External Fan Fault	X			14-53
25	Brake resistor short-circuited	X			
26	Brake resistor power limit	(X)	(X)		2-13
27	Brake chopper short-circuited	X	X		
28	Brake check	(X)	(X)		2-15
29	Power board overtemp.	X	X	X	
30	Motor phase U missing	(X)	(X)	(X)	4-58
31	Motor phase V missing	(X)	(X)	(X)	4-58
32	Motor phase W missing	(X)	(X)	(X)	4-58
33	Soft-charge fault		X	X	
34	Serial communication bus fault	X	X		
36	Line failure	X	X		
38	Internal Fault		X	X	
40	Overload of Digital Output Terminal 27	(X)			5-00, 5-01
41	Overload of Digital Output Terminal 29	(X)			5-00, 5-02
42	Overload of Digital Output On X30/6	(X)			5-32
42	Overload of Digital Output On X30/7	(X)			5-33
47	24 V supply low	X	X	X	
48	1.8 V supply low		X	X	
49	Speed limit	X			
50	AMA calibration failed		X		
51	AMA check $U_{nom}$ and $I_{nom}$		X		
52	AMA low $I_{nom}$		X		
53	AMA motor too big		X		
54	AMA motor too small		X		
55	AMA parameter out of range		X		
56	AMA interrupted by user		X		
57	AMA timeout		X		
58	AMA internal fault	X	X		
59	Current limit	X			



<b>Alarm/Warning code list</b>					
No.	Description	Warning	Alarm/Trip	Alarm/Trip Lock	Parameter Reference
61	Tracking Error	(X)	(X)		4-30
62	Output Frequency at Maximum Limit	X			
63	Mechanical Brake Low		(X)		2-20
64	Voltage Limit	X			
65	Control Board Overtemperature	X	X	X	
66	Heatsink Temperature Low	X			
67	Option Configuration Has Changed		X		
68	Safe Stop Activated		X		
70	Illegal FC configuration			X	
80	Drive Initialized to Default Value		X		
90	Encoder Loss	(X)	(X)		17-61
91	Analog input 54 wrong settings			X	S202
100-199	See Instruction Manual for MCO 305				
250	New spare part			X	14-23
251	New Type Code		X	X	

(X) Dependent on parameter

A trip is the action when an alarm has appeared. The trip will coast the motor and can be reset by pressing the reset button or by a digital input (Par. 5-1\* [1]). The origin event that causes an alarm cannot damage the drive or result in dangerous conditions. A trip lock is an action when an alarm occurs that may cause damage to the drive or its

connected parts. A trip lock situation can only be reset by a power cycling.

<i>LED indication</i>	
Warning	yellow
Alarm	flashing red
Trip-locked	yellow and red



**Description of Alarm Word, Warning Word, and extended Status Word**

<b>Alarm Word Extended Status Word</b>					
<b>Bit</b>	<b>Hex</b>	<b>Dec</b>	<b>AlarmWord</b>	<b>WarningWord</b>	<b>ExtendedStatusWord</b>
0	00000001	1	Brake Check	Brake Check	Ramping
1	00000002	2	Pwr. Card Temp	Pwr. Card Temp	AMA Running
2	00000004	4	Ground Fault	Ground Fault	Start CW/CCW
3	00000008	8	Ctrl.Card Temp	Ctrl.Card Temp	Slow-down
4	00000010	16	Ctrl. Word TO	Ctrl. Word TO	Catch Up
5	00000020	32	Overcurrent	Overcurrent	Feedback High
6	00000040	64	Torque Limit	Torque Limit	Feedback Low
7	00000080	128	Motor Th Over	Motor Th Over	Output Current High
8	00000100	256	Motor ETR Over	Motor ETR Over	Output Current Low
9	00000200	512	Inverter Overld.	Inverter Overld.	Output Freq High
10	00000400	1024	DC Under-volt	DC Under-volt	Output Freq Low
11	00000800	2048	DC Over-volt	DC Over-volt	Brake Check OK
12	00001000	4096	Short Circuit	DC Voltage Low	Braking Max
13	00002000	8192	Soft-charge fault	DC Voltage High	Braking
14	00004000	16384	Line ph. Loss	Line ph. Loss	Out of Speed Range
15	00008000	32768	AMA Not OK	No Motor	OVC Active
16	00010000	65536	Live Zero Error	Live Zero Error	
17	00020000	131072	Internal Fault	10 V Low	
18	00040000	262144	Brake Overload	Brake Overload	
19	00080000	524288	U-phase Loss	Brake Resistor	
20	00100000	1048576	V-phase Loss	Brake IGBT	
21	00200000	2097152	W-phase Loss	Speed Limit	
22	00400000	4194304	Ser. com. bus fault	Ser. com. bus fault	
23	00800000	8388608	24 V Supply Low	24 V Supply Low	
24	01000000	16777216	Line Failure	Line Failure	
25	02000000	33554432	1.8 V Supply Low	Current Limit	
26	04000000	67108864	Brake Resistor	Low Temp	
27	08000000	134217728	Brake IGBT	Voltage Limit	
28	10000000	268435456	Option Change	Unused	
29	20000000	536870912	Drive Initialized	Unused	
30	40000000	1073741824	Safe Stop	Unused	
31	80000000	2147483648	Mech. brake low	Extended Status Word	

The alarm words, warning words and extended status words can be read out via the serial communication bus (or optional serial communication bus) for diagnosis. See also par. 16-90, 16-92, and 16-94.





**WARNING 1**
**10 Volts low:**

The 10 V voltage from terminal 50 on the control card is below 10 V.

Remove some of the load from terminal 50, as the 10 V supply is overloaded. Max. 15 mA or minimum 590 Ω.

**WARNING/ALARM 2**
**Live zero error:**

The signal on terminal 53 or 54 is less than 50% of the value set in par. 6-10, 6-12, 6-20 or 6-22, respectively.

**WARNING/ALARM 3**
**No motor:**

No motor has been connected to the output of the adjustable frequency drive.

**WARNING/ALARM 4**
**Line phase loss:**

A phase is missing on the supply side, or the line voltage imbalance is too high.

This message also appears in case of a fault in the input rectifier on the adjustable frequency drive.

Check the supply voltage and supply currents to the adjustable frequency drive.

**WARNING 5**
**DC link voltage high:**

The intermediate circuit voltage (DC) is higher than the overvoltage limit of the control system. The adjustable frequency drive is still active.

**WARNING 6**
**DC link voltage low**

The intermediate circuit voltage (DC) is below the undervoltage limit of the control system. The adjustable frequency drive is still active.

**WARNING/ALARM 7**
**DC overvoltage:**

If the intermediate circuit voltage exceeds the limit, the adjustable frequency drive trips after a given period of time.

Possible corrections:

Connect a brake resistor

Extend the ramp time

Activate functions in par. 2-10

Increase par. 14-26

Alarm/warning limits:			
FC 300 Series	3 x 200-240 V [VDC]	3 x 380 - 500 V [VDC]	3 x 525-600 V [VDC]
Undervoltage	185	373	532
Voltage warning low	205	410	585
Voltage warning high (w/o brake - w/ brake)	390/405	810/840	943/965
Overvoltage	410	855	975

The voltages stated are the intermediate circuit voltages of the FC 300 with a tolerance of ± 5%. The corresponding line voltage is the intermediate circuit voltage (DC link) divided by 1.35.

**WARNING/ALARM 8**
**DC undervoltage:**

If the intermediate circuit voltage (DC) drops below the "voltage warning low" limit (see table above), the adjustable frequency drive checks if 24 V backup supply is connected.

If no 24 V backup supply is connected, the adjustable frequency drive trips after a given period of time, depending on the unit.

To check whether the supply voltage matches the adjustable frequency drive, see *General Specifications*.

**WARNING/ALARM 9**
**Inverter overloaded:**

The adjustable frequency drive is about to cut out because of an overload (too high current for too long). The counter for electronic, thermal inverter protection gives a warning at 98% and trips at 100%, while giving an alarm. You cannot reset the adjustable frequency drive until the counter is below 90%.

The fault is that the adjustable frequency drive is overloaded by more than 100% for too long.

**WARNING/ALARM 10**
**Motor ETR overtemperature:**

According to the electronic thermal protection (ETR), the motor is too hot. You can choose if you want the adjustable frequency drive to give a warning or an alarm when the counter reaches 100% in par. 1-90. The fault is that the motor is overloaded by more than 100% for too long. Check that the motor par. 1-24 is set correctly.



**WARNING/ALARM 11**
**Motor thermistor overtemp.:**

The thermistor or the thermistor connection is disconnected. You can choose if you want the adjustable frequency drive to give a warning or an alarm when the counter reaches 100% in par. 1-90. Make sure that the thermistor is connected correctly between terminal 53 or 54 (analog voltage input) and terminal 50 (+ 10 V supply), or between terminal 18 or 19 (digital input PNP only) and terminal 50. If aKTY sensor is used, check for correct connection between terminal 54 and 55.

**WARNING/ALARM 12**
**Torque limit:**

The torque is higher than the value in par. 4-16 (in motor operation), or the torque is higher than the value in par. 4-17 (in regenerative operation).

**WARNING/ALARM 13**
**Overcurrent:**

The inverter peak current limit (approximately 200% of the rated current) is exceeded. The warning will last approximately 8-12 sec., then the adjustable frequency drive trips and issues an alarm. Turn off the adjustable frequency drive and check if the motor shaft can be turned and if the motor size matches the adjustable frequency drive.

If extended mechanical brake control is selected, trip can be reset externally.

**ALARM 14**
**Ground fault:**

There is a discharge from the output phases to ground, either in the cable between the adjustable frequency drive and the motor or in the motor itself.

Turn off the adjustable frequency drive and remove the ground fault.

**ALARM 15**
**Incomplete hardware:**

A fitted option is not handled by the present control board (hardware or software).

**ALARM 16**
**Short-circuit:**

There is a short-circuit in the motor or on the motor terminals.

Turn off the adjustable frequency drive and remove the short-circuit.

**WARNING/ALARM 17**
**Control word timeout:**

There is no communication to the adjustable frequency drive.

The warning will only be active when par. 8-04 is NOT set to *OFF*.

If par. 8-04 is set to *Stop* and *Trip*, a warning appears and the adjustable frequency drive ramps down until it trips, while giving an alarm.

par. 8-03 *Control word Timeout Time* could possibly be increased.

**WARNING 23**
**Internal fan fault:**

The fan warning function is an extra protection function that checks if the fan is running/mounted. The fan warning can be disabled in *Fan Monitor*, par. 14-53, (set to [0] Disabled).

**WARNING 24**
**External fan fault:**

The fan warning function is an extra protection function that checks if the fan is running/mounted. The fan warning can be disabled in *Fan Monitor*, par. 14-53, (set to [0] Disabled).

**WARNING 25**
**Brake resistor short-circuited:**

The brake resistor is monitored during operation. If it short-circuits, the brake function is disconnected and the warning appears. The adjustable frequency drive still works, but without the brake function. Turn off the adjustable frequency drive and replace the brake resistor (see par. 2-15 *Brake Check*).

**ALARM/WARNING 26**
**Brake resistor power limit:**

The power transmitted to the brake resistor is calculated as a percentage, as a mean value over the last 120 s, on the basis of the resistance value of the brake resistor (par. 2-11) and the intermediate circuit voltage. The warning is active when the dissipated braking energy is higher than 90%. If *Trip* [2] has been selected in par. 2-13, the adjustable frequency drive cuts out and issues this alarm when the dissipated braking energy is higher than 100%.



**WARNING 27****Brake chopper fault:**

The brake transistor is monitored during operation, and if it short-circuits, the brake function disconnects and the warning is issued. The adjustable frequency drive is still able to run, but since the brake transistor has short-circuited, substantial power is transmitted to the brake resistor, even if it is inactive.

Turn off the adjustable frequency drive and remove the brake resistor.



Warning: There is a risk of substantial power being transmitted to the brake resistor if the brake transistor is short-circuited.

**ALARM/WARNING 28****Brake check failed:**

Brake resistor fault: the brake resistor is not connected/working.

**ALARM 29****Drive overtemperature:**

If the enclosure is IP 20 or IP 21/Type 1, the cut-out temperature of the heatsink is 203°F  $\pm$ 5 ° F [95°C  $\pm$ 5 °C]. The temperature fault cannot be reset until the temperature of the heatsink is below 158° C  $\pm$ 5° F [70 °C  $\pm$ 5° C].

The fault could be a result of:

- Ambient temperature too high
- Motor cable too long

**ALARM 30****Motor phase U missing:**

Motor phase U between the adjustable frequency drive and the motor is missing.

Turn off the adjustable frequency drive and check motor phase U.

**ALARM 31****Motor phase V missing:**

Motor phase V between the adjustable frequency drive and the motor is missing.

Turn off the adjustable frequency drive and check motor phase V.

**ALARM 32****Motor phase W missing:**

Motor phase W between the adjustable frequency drive and the motor is missing.

Turn off the adjustable frequency drive and check motor phase W.

**ALARM 33****Soft-charge fault:**

Too many powerups have occurred within a short period of time. See the chapter *General Specifications* for the allowed number of power-ups within one minute.

**WARNING/ALARM 34****Ser. com. bus fault:**

The serial communication bus on the communication option card is not working.

**WARNING/ALARM 36****Line failure:**

This warning/alarm is only active if the supply voltage to the adjustable frequency drive is lost and parameter 14-10 is NOT set to OFF. Possible correction: check the fuses to the adjustable frequency drive

**ALARM 38****Internal fault:**

When this alarm sounds, it may be necessary to contact your Danfoss supplier. Some typical alarm messages:

- 0 The serial port cannot be initialized. Serious hardware failure
- 256 The power EEPROM data is defective or too old.
- 512 The control board EEPROM data is defective or too old.
- 513 Communication timeout Reading EEPROM data
- 514 Communication timeout Reading EEPROM data
- 515 The Application Orientated Control cannot recognize the EEPROM data.
- 516 Cannot write to the EEPROM because a write command is in progress.
- 517 The write command has timed out.
- 518 Failure in the EEPROM
- 519 (1027 indicates a possible hardware failure) (1027 indicates a possible hardware failure)
- 1281 Digital Signal Processor flash timeout
- 1282 Power micro software version mismatch
- 1283 Power EEPROM data version mismatch



- 1284 Cannot read Digital Signal Processor software version
- 1299 Option SW in slot A is too old.
- 1300 Option SW in slot B is too old.
- 1301 Option SW in slot C0 is too old.
- 1302 Option SW in slot C1 is too old.
- 1315 Option SW in slot A is not supported (not allowed).
- 1316 Option SW in slot B is not supported (not allowed).
- 1317 Option SW in slot C0 is not supported (not allowed).
- 1318 Option SW in slot C1 is not supported (not allowed).
- 1536 An exception in the Application Orientated Control is registered. Debug information written in LCP
- 1792 DSP watchdog is active. Debugging of power part data Motor Orientated Control data not transferred correctly
- 2049 Power data restarted
- 2315 Missing SW version from power unit
- 2816 Stack overflow Control board module
- 2817 Scheduler slow tasks
- 2818 Fast tasks
- 2819 Parameter thread
- 2820 LCP stack overflow
- 2821 Serial port overflow
- 2822 USB port overflow
- 3072-5 Parameter value is outside its limits.
- 122 Perform an initialization. Parameter number causing the alarm: Subtract the code from 3072. Ex Error code 3238:  $3238 - 3072 = 166$  is outside the limit
- 5123 Option in slot A: Hardware incompatible with Control board hardware
- 5124 Option in slot B: Hardware incompatible with Control board hardware
- 5125 Option in slot C0: Hardware incompatible with Control board hardware
- 5126 Option in slot C1: Hardware incompatible with Control board hardware
- 5376-6 Out of memory
- 231

**WARNING 40****Overload of Digital Output Terminal 27:**

Check the load connected to terminal 27 or remove short-circuit connection. Check parameters 5-00 and 5-01.

**WARNING 41****Overload of Digital Output Terminal 29:**

Check the load connected to terminal 29 or remove short-circuit connection. Check parameters 5-00 and 5-02.

**WARNING 42****Overload of Digital Output On X30/6 :**

Check the load connected to X30/6 or remove short-circuit connection. Check parameter 5-32.

**WARNING 42****Overload of Digital Output On X30/7 :**

Check the load connected to X30/7 or remove short-circuit connection. Check parameter 5-33.

**WARNING 47****24 V supply low:**

The external 24 V DC backup power supply may be overloaded; otherwise contact your Danfoss supplier.

**WARNING 48****1.8 V supply low:**

Contact your Danfoss supplier.

**WARNING 49****Speed limit:**

The speed is not within the range specified in par. 4-11 and par. 4-13.

**ALARM 50****AMA calibration failed:**

Contact your Danfoss supplier.

**ALARM 51****AMA check Unom and Inom:**

The setting of motor voltage, motor current and motor power is presumably wrong. Check the settings.

**ALARM 52****AMA low Inom:**

The motor current is too low. Check the settings.

**ALARM 53****AMA motor too big:**

The motor is too big for the AMA to be carried out.



**ALARM 54****AMA motor too small:**

The motor is too big for the AMA to be carried out.

**ALARM 55****AMA par. out of range:**

The par. values found from the motor are outside the acceptable range.

**ALARM 56****AMA interrupted by user:**

The AMA has been interrupted by the user.

**ALARM 57****AMA timeout:**

Try to start the AMA again a number of times, until the AMA is carried out. Please note that repeated runs may heat the motor to a level where the resistances  $R_s$  and  $R_r$  are increased. In most cases, however, this is not critical.

**ALARM 58****AMA internal fault:**

Contact your Danfoss supplier.

**WARNING 59****Current limit:**

Contact your Danfoss supplier.

**WARNING 61****Encoder loss:**

Contact your Danfoss supplier.

**WARNING 62****Output Frequency at Maximum Limit:**

The output frequency is higher than the value set in par. 4-19.

**ALARM 63****Mechanical Brake Low:**

The actual motor current has not exceeded the "release brake" current within the "Start delay" time window.

**WARNING 64****Voltage Limit:**

The load and speed combinations demand a motor voltage higher than the actual DC link voltage.

**WARNING/ALARM/TRIP 65****Control Card Overtemperature:**

Control card overtemperature: The cut-out temperature of the control card is 176°F [80°C].

**WARNING 66****Heatsink Temperature Low:**

The heatsink temperature is measured at 32°F [0°C]. This could indicate that the temperature sensor is defective and that the fan speed has thus increased to the maximum, if the power part or control card is very hot.

**ALARM 67****Option Configuration has Changed:**

One or more options has either been added or removed since the last power-down.

**ALARM 68****Safe Stop Activated:**

Safe Stop has been activated. To resume normal operation, apply 24 V DC to terminal 37, then send a reset signal (via bus, digital I/O, or by pressing [RESET]). For correct and safe use of the Safe Stop function, follow the related information and instructions in the Design Guide

**ALARM 70****Illegal FC Configuration:**

Current combination of control board and power board is illegal.

**ALARM 80****Drive Initialized to Default Value:**

Parameter settings are initialized to default setting after a manual (three-finger) reset.

**ALARM 91****Analog Input 54 Wrong Settings:**

Switch S202 has to be set in position OFF (voltage input) when a KTY sensor is connected to analog input terminal 54.

**ALARM 250****New Spare Part:**

The power or Switch Mode Power Supply has been exchanged. The adjustable frequency drive type code must be restored in the EEPROM. Select the correct type code in Par 14-23 according to the label on unit. Remember to select 'Save to EEPROM' to complete.

**ALARM 251****New Type Code:**

The adjustable frequency drive has a new type code.



# Index

## A

Abbreviations	7
Ac Line Supply Interference	115
Access To Control Terminals	97
Accessory Bag	85
Acoustic Noise	67
Aggressive Environments	17
Air Humidity	17
Alarm Messages	157
Aluminum Conductors	102
Ama	120
Analog Inputs	9
Analog Inputs	63
Analog Inputs	9
Analog Inputs - Terminal X30/11, 12	126
Analog Output	64
Analog Output - Terminal X30/8	126
Automatic Adaptations To Ensure Performance	71
Automatic Motor Adaptation	120
Automatic Motor Adaptation (ama)	104

## B

Basic Wiring Example	99
Brake Connection Option	105
Brake Control	162
Brake Function	46
Brake Resistor	43
Brake Resistors	134
Braking Energy	10, 46
Braking Time	147
Break-away Torque	9

## C

Cable Clamp	114
Cable Clamps	111
Cable Length And Cross-section	102
Cable Lengths And Cross-sections	61
Catch Up/slow-down	24
Clockwise Rotation	108
Coasting	8, 147
Coasting	149
Communication Option	163
Connection To Line Power	90
Control Cables	100
Control Cables	101
Control Cables	110
Control Card Performance	65
Control Card, +10 V Dc Output	65
Control Card, 24 V Dc Output	64
Control Card, Rs-485 Serial Communication	64
Control Card, Usb Serial Communication	66
Control Characteristics	65
Control Terminals	97, 98
Control Word	147
Control Word According To Profidrive Profile (ctw)	151

Cooling	71
Cooling Conditions	86

## D

Dc Brake	147
Dc Bus Connection	105
Dc Link	161
Dead Band	27
Dead Band Around Zero	27
Decoupling Plate	92
Definitions	8
Derating For Ambient Temperature	68
Derating For Installing Long Motor Cables Or Cables With Larger Cross-section	71
Derating For Low Air Pressure	70
Derating For Running At Low Speed	71
Devicenet	5, 76
Digital Inputs - Terminal X30/1-4	125
Digital Inputs:	62
Digital Output	64
Digital Outputs - Terminal X30/6, 7	126
Direction Of Motor Rotation	108
Disposal Instructions	14
Drive Configurator	73

## E

Efficiency	66
Electrical Installation	98, 100, 102
Electrical Installation - Emc Precautions	110
Electrical Terminals	100
Electro-mechanical Brake	119
Emc Test Results	40
Encoder Feedback	19
Equalizing Cable	114
Etr	108, 161
External 24 V Dc Supply	133
Extreme Running Conditions	49

## F

Fc Profile	147
Flux	21
Freeze Output	8
Freeze Reference	24
Fuses	94

## G

Galvanic Isolation (pelv)	42
General Warning	6
Ground Leakage Current	43
Ground Leakage Current	110
Grounding	114
Grounding Of Shielded/armored Control Cables	114

## H

Harmonic Filters	80
High Voltage Test	110
Hoist Mechanical Brake	47
Hold Output Frequency	148

## I

Intermediate Circuit	46, 49, 67, 161
Internal Current Control In Vvcplus Mode	22

## J

Jog	148
Jog	8

## K

Kty Sensor	162
------------	-----

## L

Lcp	8, 10, 22, 134
Leakage Current	43
Line Drop-out	50
Line Supply	55, 60
Line Supply	12
Line Supply (L1, L2, L3)	61
Local (hand On) And Remote (auto On) Control	22

## M

Mechanical Brake	46
Mechanical Dimensions	83
Mechanical Dimensions	84
Mechanical Mounting	86
Moment Of Inertia	49
Motor Cables	102
Motor Cables	110
Motor Connection	92
Motor Feedback	21
Motor Nameplate	103
Motor Output	61
Motor Parameters	120
Motor Phases	49
Motor Protection	62, 108
Motor Rotation	108
Motor Thermal Protection	50, 108
Motor Thermal Protection	150
Motor Voltage	67
Motor-generated Overvoltage	49

## N

Nameplate Data	103
Non-ul Compliance	95

## O

Ordering Form Type Code	73
Ordering Numbers	73

Ordering Numbers: Brake Resistors	77
Ordering Numbers: Harmonic Filters	80
Ordering Numbers: Options And Accessories	76
Ordering Numbers: Sine-wave Filter Modules	80
Output Performance (u, V, W)	61

## P

Peak Voltage On Motor	67
Plc	114
Potentiometer Reference	118
Process Pid Control	34
Profibus	5, 76
Programming Of Torque Limit And Stop	119
Protection	17, 42, 43, 94
Protection And Features	62
Pulse Start/stop	117
Pulse/encoder Inputs	63

## R

Rated Motor Speed	8
Rcd	11, 43
Reference Handling	24
Relay Connection	105
Relay Outputs	65
Removal Of Knockouts For Extra Cables	89
Residual Current Device	43, 115
Rise Time	67
Rs-485	137
Rs-485 Bus Connection	109

## S

Safe Stop	50
Safety Ground Connection	110
Scaling Of References And Feedback	26
Serial Communication	9, 66, 114
Shield/armored	101
Short Circuit (motor Phase – Phase)	49
Side-by-side Installation	86
Sine-wave Filter	94, 135
Sine-wave Filters	135
Smart Logic Control	48
Software Versions	76
Speed Pid	19, 20
Speed Pid Control	31
Start/stop	117
Static Overload In Vvcplus Mode	50
Status Word	149
Status Word According To Profidrive Profile (stw)	154
Surroundings	65
Switches S201, S202, And S801	102
Switching Frequency	102
Switching On The Output	49

## T

Thermistor	11
Torque Characteristics	61
Torque Control	19



**U**

Usb Connection .....	97, 98
Use Of Emc-correct Cables .....	113

**V**

Vibration And Shock .....	18
Voltage Level .....	62
Vvcpplus .....	12, 20

**W**

Warnings .....	157
----------------	-----