

## Contents

<b>1. How to Read this Design Guide</b>	<b>5</b>
How to Read this Design Guide	5
Approvals	5
Symbols	5
Abbreviations	6
Definitions	6
<b>2. Safety and Conformity</b>	<b>13</b>
Safety Precautions	13
Disposal Instruction	14
<b>3. Introduction to FC 300</b>	<b>19</b>
Product Overview	19
Control Principle	21
FC 300 Controls	21
FC 301 vs. FC 302 Control Principle	21
Control Structure in VVCplus	22
Control Structure in Flux Sensorless (FC 302 only)	23
Control Structure in Flux with Motor Feedback	23
Internal Current Control in VVCplus Mode	24
Local (Hand On) and Remote (Auto On) Control	24
Reference Handling	26
Scaling of References and Feedback	27
Dead Band Around Zero	28
Speed PID Control	31
Process PID Control	34
Ziegler Nichols Tuning Method	38
EMC Immunity	41
Earth Leakage Current	43
Selection of Brake Resistor	43
Mechanical Brakecontrol	46
Hoist Mechanical Brake	47
Safe Stop of FC 300	50
Safe Stop Installation (FC 302 and FC 301 - A1 enclosure only)	52
Safe Stop Commissioning Test	53
<b>4. FC 300 Selection</b>	<b>55</b>
Electrical Data	55
General Specifications	69
Efficiency	73

Acoustic Noise	74
du/dt conditions	75
Purpose of derating	75
Automatic adaptations to ensure performance	82
<b>5. How to Order</b>	<b>83</b>
Drive Configurator	83
Ordering Form Type Code	83
<b>6. How to Install</b>	<b>93</b>
Mechanical Dimension	93
Mechanical Installation	97
Accessory Bag	97
Electrical Installation	100
Removal of Knockouts for Extra Cables	101
Connection to Mains and Earthing	101
Motor Connection	103
Fuses	105
Access to Control Terminals	108
Control Terminals	108
Electrical Installation, Control Terminals	108
Basic Wiring Example	110
Electrical Installation, Control Cables	111
Motor Cables	112
Switches S201, S202, and S801	113
Additional Connections	117
Relay Connection	118
Relay Output	118
Parallel Connection of Motors	118
Motor Thermal Protection	120
Motor Thermal Protection	120
How to Connect a PC to the FC 300	121
The FC 300 PC Software	121
Residual Current Device	126
<b>7. Application Examples</b>	<b>127</b>
Start/Stop	127
Pulse Start/Stop	127
Potentiometer Reference	128
Encoder Connection	129
Encoder Direction	129

Closed Loop Drive System	129
Programming of Torque Limit and Stop	129
Smart Logic Control Programming	131
<b>8. Options and Accessories</b>	<b>133</b>
Mounting of Option Modules in Slot A	133
Mounting of Option Modules in Slot B	133
General Purpose Input Output Module MCB 101	133
Encoder Option MCB 102	136
Resolver Option MCB 103	138
Relay Option MCB 105	140
24 V Back-Up Option MCB 107 (Option D)	142
MCB 112 VLT® PTC Thermistor Card	143
IP 21/IP 4X/ TYPE 1 Enclosure Kit	146
Sine-wave Filters	147
<b>9. RS-485 Installation and Set-up</b>	<b>149</b>
RS-485 Installation and Set-up	149
Network Configuration	151
FC Protocol Message Framing Structure - FC 300	151
Examples	157
Danfoss FC Control Profile	158
<b>10. Troubleshooting</b>	<b>169</b>
Warnings/Alarm Messages	169
<b>Index</b>	<b>178</b>



# 1. How to Read this Design Guide

1

## 1.1.1. How to Read this Design Guide

This Design Guide will introduce all aspects of your FC 300.

### Available literature for FC 300

- The VLT® AutomationDrive FC 300 Operating Instructions MG.33.AX.YY provide the necessary information for getting the drive up and running.
- The VLT® AutomationDrive FC 300 Design Guide MG.33.BX.YY entails all technical information about the drive and customer design and applications.
- The VLT® AutomationDrive FC 300 Programming Guide MG.33.MX.YY provides information on how to programme and includes complete parameter descriptions.
- The VLT® AutomationDrive FC 300 Profibus Operating Instructions MG.33.CX.YY provide the information required for controlling, monitoring and programming the drive via a Profibus fieldbus.
- The VLT® AutomationDrive FC 300 DeviceNet Operating Instructions MG.33.DX.YY provide the information required for controlling, monitoring and programming the drive via a DeviceNet fieldbus.

X = Revision number

YY = Language code

Danfoss Drives technical literature is also available online at [www.danfoss.com/BusinessAreas/DrivesSolutions/Documentations/Technical+Documentation](http://www.danfoss.com/BusinessAreas/DrivesSolutions/Documentations/Technical+Documentation).

## 1.1.2. Approvals



## 1.1.3. Symbols

Symbols used in this guide.

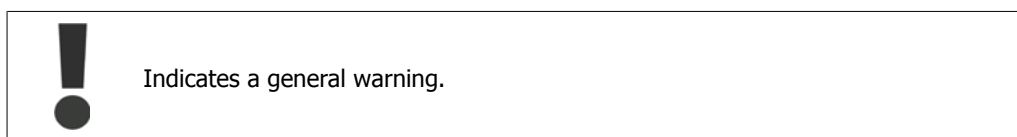
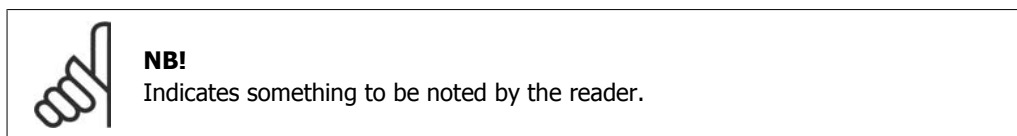

1

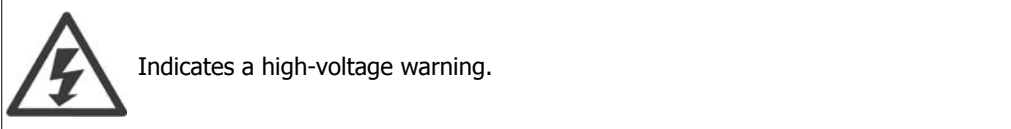

\* Indicates default setting

### 1.1.4. Abbreviations

Alternating current	AC
American wire gauge	AWG
Ampere/AMP	A
Automatic Motor Adaptation	AMA
Current limit	$I_{LIM}$
Degrees Celsius	°C
Direct current	DC
Drive Dependent	D-TYPE
Electro Magnetic Compatibility	EMC
Electronic Thermal Relay	ETR
drive	FC
Gram	g
Hertz	Hz
Kilohertz	kHz
Local Control Panel	LCP
Meter	m
Millihenry Inductance	mH
Milliampere	mA
Millisecond	ms
Minute	min
Motion Control Tool	MCT
Nanofarad	nF
Newton Meters	Nm
Nominal motor current	$I_{M,N}$
Nominal motor frequency	$f_{M,N}$
Nominal motor power	$P_{M,N}$
Nominal motor voltage	$U_{M,N}$
Parameter	par.
Protective Extra Low Voltage	PELV
Printed Circuit Board	PCB
Rated Inverter Output Current	$I_{INV}$
Revolutions Per Minute	RPM
Second	s
Torque limit	$T_{LIM}$
Volts	V

### 1.1.5. Definitions

#### Drive:

#### D-TYPE

Size and type of the connected drive (dependencies).

#### $I_{VLT,MAX}$

The maximum output current.

#### $I_{VLT,N}$

The rated output current supplied by the frequency converter.

#### $U_{VLT, MAX}$

The maximum output voltage.

#### Input:

Control command

You can start and stop the connected motor by means of LCP and the digital inputs. Functions are divided into two groups.

Functions in group 1 have higher priority than functions in group 2.

Group 1	Reset, Coasting stop, Reset and Coasting stop, Quick-stop, DC braking, Stop and the "Off" key.
Group 2	Start, Pulse start, Reversing, Start reversing, Jog and Freeze output

### Motor:

$f_{JOG}$

The motor frequency when the jog function is activated (via digital terminals).

$f_M$

The motor frequency.

$f_{MAX}$

The maximum motor frequency.

$f_{MIN}$

The minimum motor frequency.

$f_{M,N}$

The rated motor frequency (nameplate data).

$I_M$

The motor current.

$I_{M,N}$

The rated motor current (nameplate data).

M-TYPE

Size and type of the connected motor (dependencies).

$n_{M,N}$

The rated motor speed (nameplate data).

$P_{M,N}$

The rated motor power (nameplate data).

$T_{M,N}$

The rated torque (motor).

$U_M$

The instantaneous motor voltage.

$U_{M,N}$

The rated motor voltage (nameplate data).

Break-away torque

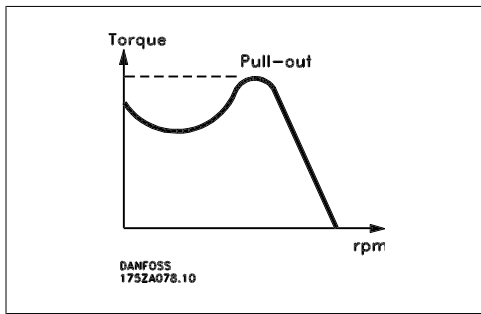

#### $\eta_{VLT}$

The efficiency of the frequency converter is defined as the ratio between the power output and the power input.

#### Start-disable command

A stop command belonging to the group 1 control commands - see this group.

#### Stop command

See Control commands.

#### **References:**

##### Analog Reference

A signal transmitted to the analog inputs 53 or 54, can be voltage or current.

##### Binary Reference

A signal transmitted to the serial communication port.

##### Preset Reference

A defined preset reference to be set from -100% to +100% of the reference range. Selection of eight preset references via the digital terminals.

##### Pulse Reference

A pulse frequency signal transmitted to the digital inputs (terminal 29 or 33).

##### Ref<sub>MAX</sub>

Determines the relationship between the reference input at 100% full scale value (typically 10 V, 20mA) and the resulting reference. The maximum reference value set in par. 3-03.

##### Ref<sub>MIN</sub>

Determines the relationship between the reference input at 0% value (typically 0V, 0mA, 4mA) and the resulting reference. The minimum reference value set in par. 3-02.

#### **Miscellaneous:**

##### Analog Inputs

The analog inputs are used for controlling various functions of the frequency converter.

There are two types of analog inputs:

Current input, 0-20 mA and 4-20 mA

Voltage input, 0-10 V DC (FC 301)

Voltage input, -10 - +10 V DC (FC 302).

##### Analog Outputs

The analog outputs can supply a signal of 0-20 mA, 4-20 mA, or a digital signal.

##### Automatic Motor Adaptation, AMA

AMA algorithm determines the electrical parameters for the connected motor at standstill.



#### Brake Resistor

The brake resistor is a module capable of absorbing the brake power generated in regenerative braking. This regenerative braking power increases the intermediate circuit voltage and a brake chopper ensures that the power is transmitted to the brake resistor.

#### CT Characteristics

Constant torque characteristics used for all applications such as conveyor belts, displacement pumps and cranes.

#### Digital Inputs

The digital inputs can be used for controlling various functions of the frequency converter.

#### Digital Outputs

The drive features two Solid State outputs that can supply a 24 V DC (max. 40 mA) signal.

#### DSP

Digital Signal Processor.

#### ETR

Electronic Thermal Relay is a thermal load calculation based on present load and time. Its purpose is to estimate the motor temperature.

#### Hiperface®

Hiperface® is a registered trademark by Stegmann.

#### Initialising

If initialising is carried out (par. 14-22), the frequency converter returns to the default setting.

#### Intermittent Duty Cycle

An intermittent duty rating refers to a sequence of duty cycles. Each cycle consists of an on-load and an off-load period. The operation can be either periodic duty or non-periodic duty.

#### LCP

The Local Control Panel (LCP) makes up a complete interface for control and programming of the FC 300 Series. The control panel is detachable and can be installed up to 3 metres from the frequency converter, i.e. in a front panel by means of the installation kit option.

#### lsb

Least significant bit.

#### msb

Most significant bit.

#### MCM

Short for Mille Circular Mil, an American measuring unit for cable cross-section. 1 MCM = 0.5067 mm<sup>2</sup>.

#### On-line/Off-line Parameters

Changes to on-line parameters are activated immediately after the data value is changed. Changes to off-line parameters are not activated until you enter [OK] on the LCP.

#### Process PID

The PID regulator maintains the desired speed, pressure, temperature, etc. by adjusting the output frequency to match the varying load.

#### Pulse Input/Incremental Encoder

An external, digital pulse transmitter used for feeding back information on motor speed. The encoder is used in applications where great accuracy in speed control is required.

#### RCD

Residual Current Device.

#### Set-up

You can save parameter settings in four Set-ups. Change between the four parameter Set-ups and edit one Set-up, while another Set-up is active.

#### SFAVM

Switching pattern called Stator Flux oriented Aynchronous Vector Modulation (par. 14-00).

#### Slip Compensation

The frequency converter compensates for the motor slip by giving the frequency a supplement that follows the measured motor load keeping the motor speed almost constant..

#### Smart Logic Control (SLC)

The SLC is a sequence of user defined actions executed when the associated user defined events are evaluated as true by the SLC. (Parameter group 13-xx).

#### FC Standard Bus

Includes RS 485 bus with FC protocol or MC protocol. See parameter 8-30.

#### Thermistor:

A temperature-dependent resistor placed where the temperature is to be monitored (frequency converter or motor).

#### Trip

A state entered in fault situations, e.g. if the frequency converter is subject to an over-temperature or when the frequency converter is protecting the motor, process or mechanism. Restart is prevented until the cause of the fault has disappeared and the trip state is cancelled by activating reset or, in some cases, by being programmed to reset automatically. Trip may not be used for personal safety.

#### Trip Locked

A state entered in fault situations when the frequency converter is protecting itself and requiring physical intervention, e.g. if the frequency converter is subject to a short circuit on the output. A locked trip can only be cancelled by cutting off mains, removing the cause of the fault, and re-connecting the frequency converter. Restart is prevented until the trip state is cancelled by activating reset or, in some cases, by being programmed to reset automatically. Trip may not be used for personal safety.

#### VT Characteristics

Variable torque characteristics used for pumps and fans.

#### VVCplus

If compared with standard voltage/frequency ratio control, Voltage Vector Control (VVC<sup>plus</sup>) improves the dynamics and the stability, both when the speed reference is changed and in relation to the load torque.

#### 60° AVM

Switching pattern called 60°Aynchronous Vector Modulation (par. 14-00).

### Power Factor

The power factor is the relation between  $I_1$  and  $I_{RMS}$ .

$$\text{Power factor} = \frac{\sqrt{3} \times U \times I_1 \times \cos\varphi}{\sqrt{3} \times U \times I_{RMS}}$$

The power factor for 3-phase control:

$$= \frac{I_1 \times \cos\varphi_1}{I_{RMS}} = \frac{I_1}{I_{RMS}} \text{ since } \cos\varphi_1 = 1$$

The power factor indicates to which extent the frequency converter imposes a load on the mains supply.

$$I_{RMS} = \sqrt{I_1^2 + I_5^2 + I_7^2 + \dots + I_n^2}$$

The lower the power factor, the higher the  $I_{RMS}$  for the same kW performance.

In addition, a high power factor indicates that the different harmonic currents are low.

The FC 300 frequency converters' built-in DC coils produce a high power factor, which minimizes the imposed load on the mains supply.



## 2. Safety and Conformity

2

### 2.1. Safety Precautions



The voltage of the frequency converter is dangerous whenever connected to mains. Incorrect installation of the motor, frequency converter or fieldbus may cause damage to the equipment, serious personal injury or death. Consequently, the instructions in this manual, as well as national and local rules and safety regulations, must be complied with.

#### Safety Regulations

1. The frequency converter must be disconnected from mains if repair work is to be carried out. Check that the mains supply has been disconnected and that the necessary time has passed before removing motor and mains plugs.
2. The [STOP/RESET] key on the control panel of the frequency converter does not disconnect the equipment from mains and is thus not to be used as a safety switch.
3. Correct protective earthing of the equipment must be established, the user must be protected against supply voltage, and the motor must be protected against overload in accordance with applicable national and local regulations.
4. The earth leakage currents are higher than 3.5 mA.
5. Protection against motor overload is not included in the factory setting. If this function is desired, set par. 1-90 to data value ETR trip or data value ETR warning.
6. Do not remove the plugs for the motor and mains supply while the frequency converter is connected to mains. Check that the mains supply has been disconnected and that the necessary time has passed before removing motor and mains plugs.
7. Please note that the frequency converter has more voltage inputs than L1, L2 and L3, when load sharing (linking of DC intermediate circuit) and external 24 V DC have been installed. Check that all voltage inputs have been disconnected and that the necessary time has passed before commencing repair work.

#### Warning against Unintended Start

1. The motor can be brought to a stop by means of digital commands, bus commands, references or a local stop, while the frequency converter is connected to mains. If personal safety considerations make it necessary to ensure that no unintended start occurs, these stop functions are not sufficient.
2. While parameters are being changed, the motor may start. Consequently, the stop key [STOP/RESET] must always be activated; following which data can be modified.
3. A motor that has been stopped may start if faults occur in the electronics of the frequency converter, or if a temporary overload or a fault in the supply mains or the motor connection ceases.



Touching the electrical parts may be fatal - even after the equipment has been disconnected from mains.

Also make sure that other voltage inputs have been disconnected, such as external 24 V DC, load sharing (linkage of DC intermediate circuit), as well as the motor connection for kinetic back up. Refer to FC 300 Operating Instructions (MG.33.A8.xx) for further safety guidelines.

**Protection Mode**

Once a hardware limit on motor current or dc-link voltage is exceeded the drive will enter "Protection mode". "Protection mode" means a change of the PWM modulation strategy and a low switching frequency to minimize losses. This continues 10 sec after the last fault and increases the reliability and the robustness of the drive while re-establishing full control of the motor.

In hoist applications "Protection mode" is not usable because the drive will usually not be able to leave this mode again and therefore it will extend the time before activating the brake – which is not recommendable.

The "Protection mode" can be disabled by setting parameter 14-26 "Trip Delay at Inverter Fault" to zero which means that the drive will trip immediately if one of the hardware limits is exceeded.

**2.2.1. Disposal Instruction**





Equipment containing electrical components may not be disposed of together with domestic waste. It must be separately collected with Electrical and Electronic waste according to local and currently valid legislation.



The FC 300 AutomationDrive DC link capacitors remain charged after power has been disconnected. To avoid electrical shock hazard, disconnect the FC 300 from the mains before carrying out maintenance. When using a PM-motor, make sure it is disconnected. Before doing service on the frequency converter wait at least the amount of time indicated below:

FC 300	380 - 500 V	0.25 - 7.5 kW	4 minutes
		11 - 75 kW	15 minutes
		90 - 200 kW	20 minutes
525 - 690 V		250 - 400 kW	40 minutes
		37 - 250 kW	20 minutes
		315 - 560 kW	30 minutes

**FC 300**  
**Design Guide**  
**Software version: 4.5x**

This Design Guide can be used for all FC 300 frequency converters with software version 4.0x. The software version number can be seen from parameter 15-43.

## 2.4.1. CE Conformity and Labelling

### What is CE Conformity and Labelling?

The purpose of CE labelling is to avoid technical trade obstacles within EFTA and the EU. The EU has introduced the CE label as a simple way of showing whether a product complies with the relevant EU directives. The CE label says nothing about the specifications or quality of the product. Frequency converters are regulated by three EU directives:

#### The machinery directive (98/37/EEC)

All machines with critical moving parts are covered by the machinery directive of January 1, 1995. Since a frequency converter is largely electrical, it does not fall under the machinery directive. However, if a frequency converter is supplied for use in a machine, we provide information on safety aspects relating to the frequency converter. We do this by means of a manufacturer's declaration.

#### The low-voltage directive (73/23/EEC)

Frequency converters must be CE labelled in accordance with the low-voltage directive of January 1, 1997. The directive applies to all electrical equipment and appliances used in the 50 - 1000 V AC and the 75 - 1500 V DC voltage ranges. Danfoss CE-labels in accordance with the directive and issues a declaration of conformity upon request.

#### The EMC directive (89/336/EEC)

EMC is short for electromagnetic compatibility. The presence of electromagnetic compatibility means that the mutual interference between different components/appliances does not affect the way the appliances work.

The EMC directive came into effect January 1, 1996. Danfoss CE-labels in accordance with the directive and issues a declaration of conformity upon request. To carry out EMC-correct installation, see the instructions in this Design Guide. In addition, we specify which standards our products comply with. We offer the filters presented in the specifications and provide other types of assistance to ensure the optimum EMC result.

The frequency converter is most often used by professionals of the trade as a complex component forming part of a larger appliance, system or installation. It must be noted that the responsibility for the final EMC properties of the appliance, system or installation rests with the installer.

## 2.4.2. What Is Covered

The EU "*Guidelines on the Application of Council Directive 89/336/EEC*" outline three typical situations of using a frequency converter. See below for EMC coverage and CE labelling.

1. The frequency converter is sold directly to the end-consumer. The frequency converter is for example sold to a DIY market. The end-consumer is a layman. He installs the frequency converter himself for use with a hobby machine, a kitchen appliance, etc. For such applications, the frequency converter must be CE labelled in accordance with the EMC directive.
2. The frequency converter is sold for installation in a plant. The plant is built up by professionals of the trade. It could be a production plant or a heating/ventilation plant designed and installed by professionals of the trade. Neither the frequency converter nor the finished plant has to be CE labelled under the EMC directive. However, the unit must comply with the basic EMC requirements of the directive. This is ensured by using components, appliances, and systems that are CE labelled under the EMC directive.
3. The frequency converter is sold as part of a complete system. The system is being marketed as complete and could e.g. be an air-conditioning system. The complete system must be CE labelled in accordance with the EMC directive. The manufacturer can ensure CE labelling under the EMC directive either by using CE labelled components or by testing the EMC of the system. If he chooses to use only CE labelled components, he does not have to test the entire system.

### 2.4.3. Danfoss VLT Frequency Converter and CE Labelling

CE labelling is a positive feature when used for its original purpose, i.e. to facilitate trade within the EU and EFTA.

However, CE labelling may cover many different specifications. Thus, you have to check what a given CE label specifically covers.

The covered specifications can be very different and a CE label may therefore give the installer a false feeling of security when using a frequency converter as a component in a system or an appliance.

Danfoss CE labels the frequency converters in accordance with the low-voltage directive. This means that if the frequency converter is installed correctly, we guarantee compliance with the low-voltage directive. Danfoss issues a declaration of conformity that confirms our CE labelling in accordance with the low-voltage directive.

The CE label also applies to the EMC directive provided that the instructions for EMC-correct installation and filtering are followed. On this basis, a declaration of conformity in accordance with the EMC directive is issued.

The Design Guide offers detailed instructions for installation to ensure EMC-correct installation. Furthermore, Danfoss specifies which our different products comply with.

Danfoss gladly provides other types of assistance that can help you obtain the best EMC result.

### 2.4.4. Compliance with EMC Directive 89/336/EEC

As mentioned, the frequency converter is mostly used by professionals of the trade as a complex component forming part of a larger appliance, system, or installation. It must be noted that the responsibility for the final EMC properties of the appliance, system or installation rests with the installer. As an aid to the installer, Danfoss has prepared EMC installation guidelines for the Power Drive system. The standards and test levels stated for Power Drive systems are complied with, provided that the EMC-correct instructions for installation are followed, see the section *Electrical Installation*.

The frequency converter has been designed to meet the IEC/EN 60068-2-3 standard, EN 50178 pkt. 9.4.2.2 at 50°C.

A frequency converter contains a large number of mechanical and electronic components. All are to some extent vulnerable to environmental effects.



The frequency converter should not be installed in environments with airborne liquids, particles, or gases capable of affecting and damaging the electronic components. Failure to take the necessary protective measures increases the risk of stoppages, thus reducing the life of the frequency converter.

Liquids can be carried through the air and condense in the frequency converter and may cause corrosion of components and metal parts. Steam, oil, and salt water may cause corrosion of components and metal parts. In such environments, use equipment with enclosure rating IP 55. As an extra protection, coated printed circuit boards can be ordered as an option.



Airborne Particles such as dust may cause mechanical, electrical, or thermal failure in the frequency converter. A typical indicator of excessive levels of airborne particles is dust particles around the frequency converter fan. In very dusty environments, use equipment with enclosure rating IP 55 or a cabinet for IP 00/IP 20/TYPE 1 equipment.

In environments with high temperatures and humidity, corrosive gases such as sulphur, nitrogen, and chlorine compounds will cause chemical processes on the frequency converter components.

Such chemical reactions will rapidly affect and damage the electronic components. In such environments, mount the equipment in a cabinet with fresh air ventilation, keeping aggressive gases away from the frequency converter.

An extra protection in such areas is a coating of the printed circuit boards, which can be ordered as an option.

	<p><b>NB!</b> Mounting frequency converters in aggressive environments increases the risk of stoppages and considerably reduces the life of the converter.</p>
---	--

Before installing the frequency converter, check the ambient air for liquids, particles, and gases. This is done by observing existing installations in this environment. Typical indicators of harmful airborne liquids are water or oil on metal parts, or corrosion of metal parts.

Excessive dust particle levels are often found on installation cabinets and existing electrical installations. One indicator of aggressive airborne gases is blackening of copper rails and cable ends on existing installations.

The frequency converter has been tested according to the procedure based on the shown standards:

The frequency converter complies with requirements that exist for units mounted on the walls and floors of production premises, as well as in panels bolted to walls or floors.









IEC/EN 60068-2-6:	Vibration (sinusoidal) - 1970
IEC/EN 60068-2-64:	Vibration, broad-band random



# 3. Introduction to FC 300

## 3.1. Product Overview

Frame size is depending on enclosure type, power range and mains voltage

Enclosure type	A1	A2	A3	A5	B1	B2	C1	C2
	 130BA339.10	 130BA340.10	 130BA341.10					
IP	20/21	20/21	20/21	55/66	21/55/66	21/55/66	21/55/66	21/55/66
NEMA	Chassis/Type 1	Chassis/Type 1	Chassis/Type 1	Type 12/Type 4X	Type 1/Type 12	Type 1/Type 12		
Rated power	0.25 – 1.5 kW (200–240 V) 0.37 – 1.5 kW (380–480 V)	0.25-3 kW (200–240 V) 0.37-4.0 kW (380-480/500V) 0.75-4 kW (525-600 V)	3.7 kW (200-240 V) 5.5-7.5 kW (380-480/500 V) 5.5-7.5 kW (525-600V )	0.25-3.7 kW (200-240 V) 0.37-7.5 kW (380-480/500 V) 0.75 -7.5 kW (525-600 V)	5.5-7.5 kW (200-240 V) 11-15 kW (380-480/500V)	11 kW (200-250 V) 18.5-22 kW (380-480/500V)	15-22 kW (200-240 V) 30-45kW (380-480/500V)	30-37 kW (200-240 V) 55-75 kW (380-480/500V)

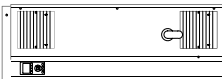
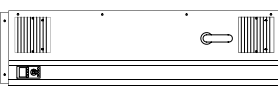
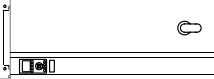
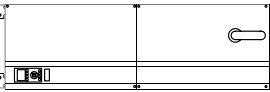
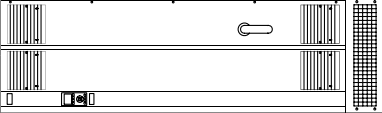
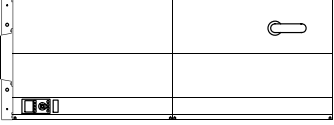
Enclosure type	D1	D2	D3	D4	E1	E2
	 <p>130BA481.10</p>	 <p>130BA482.10</p>	 <p>130BA478.10</p>	 <p>130BA479.10</p>	 <p>130BA483.10</p>	 <p>130BA480.10</p>
IP	21/54	21/54	00	00	21/54	00
Enclosure protection	Type I / Type 12	Type I / Type 12	Chassis	Chassis	Type I / Type 12	Chassis
Rated power	90 - 110 kW at 400 V (380 - 500 V) 110 - 132 kW at 690 V (525-690 V)	132 - 200 kW at 400 V (380 - 500 V) 160 - 315 kW at 690 V (525-690 V)	90 - 110 kW at 400 V (380 - 500 V) 110 - 132 kW at 690 V (525-690 V)	132 - 200 kW at 400 V (380 - 500 V) 160 - 315 kW at 690 V (525-690 V)	250 - 400 kW at 400 V (380 - 500 V) 355 - 560 kW at 690 V (525-690 V)	250 - 400 kW at 400 V (380 - 500 V) 355 - 560 kW at 690 V (525-690 V)

### 3.2.1. Control Principle

A frequency converter rectifies AC voltage from mains into DC voltage, after which this DC voltage is converted into a AC current with a variable amplitude and frequency.

The motor is supplied with variable voltage / current and frequency, which enables infinitely variable speed control of three-phased, standard AC motors and permanent magnet synchronous motors.

### 3.2.2. FC 300 Controls

The frequency converter is capable of controlling either the speed or the torque on the motor shaft. Setting par. 1-00 determines the type of control.

Speed control:

**There are two types of speed control:**

- Speed open loop control which does not require any feedback (sensorless).
- Speed closed loop control in the form of a PID control that requires a speed feedback to an input. A properly optimised speed closed loop control will have higher accuracy than a speed open loop control.

Selects which input to use as speed PID feedback in par. 7-00.

Torque control (FC 302 only):

Torque control is part of the motor control and correct settings of motor parameters are very important. The accuracy and settling time of the torque control are determined from *Flux with motor feedback* (par. 1-01 *Motor Control Principle*).

- Flux with encoder feedback offers superior performance in all four quadrants and at all motor speeds.

Speed / torque reference:

The reference to these controls can either be a single reference or be the sum of various references including relatively scaled references. The handling of references is explained in detail later in this section.

### 3.2.3. FC 301 vs. FC 302 Control Principle

FC 301 is a general purpose frequency converter for variable speed applications. The control principle is based on Voltage Vector Control (VVC<sup>plus</sup>).

FC 301 can handle asynchronous motors only.

The current sensing principle in FC 301 is based on current measurement in the DC link or motor phase. The ground fault protection on the motor side is solved by a de-saturation circuit in the IGBTs connected to the control board.

Short circuit behaviour on FC 301 depends on the current transducer in the positive DC link and the desaturation protection with feedback from the 3 lower IGBT's and the brake.

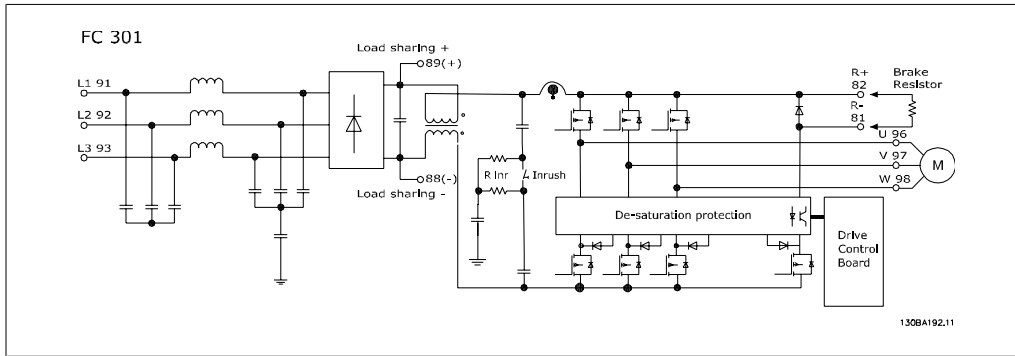

FC 302 is a high performance frequency converter for demanding applications. The frequency converter can handle various kinds of motor control principles such as U/f special motor mode, VVC<sup>plus</sup> or Flux Vector motor control.

FC 302 is able to handle Permanent Magnet Synchronous Motors (Brushless servo motors) as well as normal squirrel cage asynchronous motors.

Short circuit behaviour on FC 302 depends on the 3 current transducers in the motor phases and the desaturation protection with feedback from the brake.

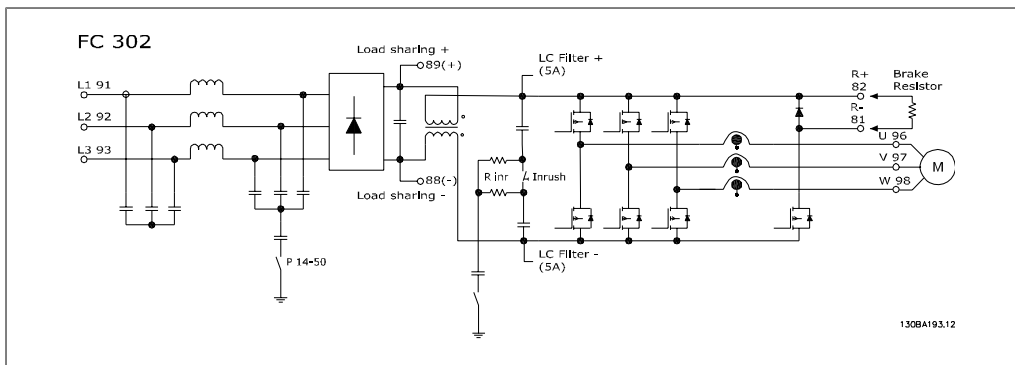

### 3.2.4. Control Structure in VVCplus

Control structure in VVC<sup>plus</sup> open loop and closed loop configurations:

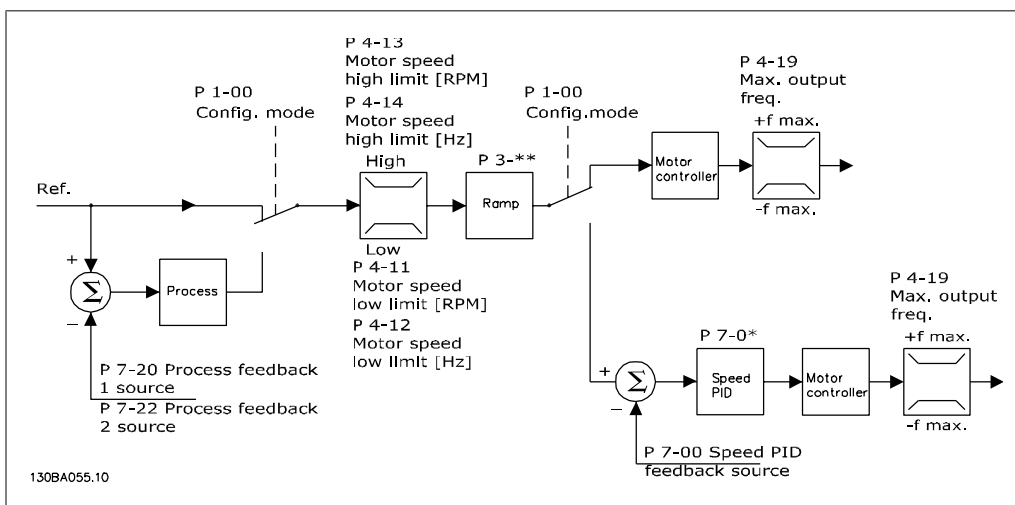

In the configuration shown in the illustration above, par. 1-01 *Motor Control Principle* is set to "VVC<sup>plus</sup> [1]" and par. 1-00 is set to "Speed open loop [0]". The resulting reference from the

reference handling system is received and fed through the ramp limitation and speed limitation before being sent to the motor control. The output of the motor control is then limited by the maximum frequency limit.

If par. 1-00 is set to "Speed closed loop [1]" the resulting reference will be passed from the ramp limitation and speed limitation into a speed PID control. The Speed PID control parameters are located in the par. group 7-0\*. The resulting reference from the Speed PID control is sent to the motor control limited by the frequency limit.

Select "Process [3]" in par. 1-00 to use the process PID control for closed loop control of e.g. speed or pressure in the controlled application. The Process PID parameters are located in par. group 7-2\* and 7-3\*.

### 3.2.5. Control Structure in Flux Sensorless (FC 302 only)

Control structure in Flux sensorless open loop and closed loop configurations.

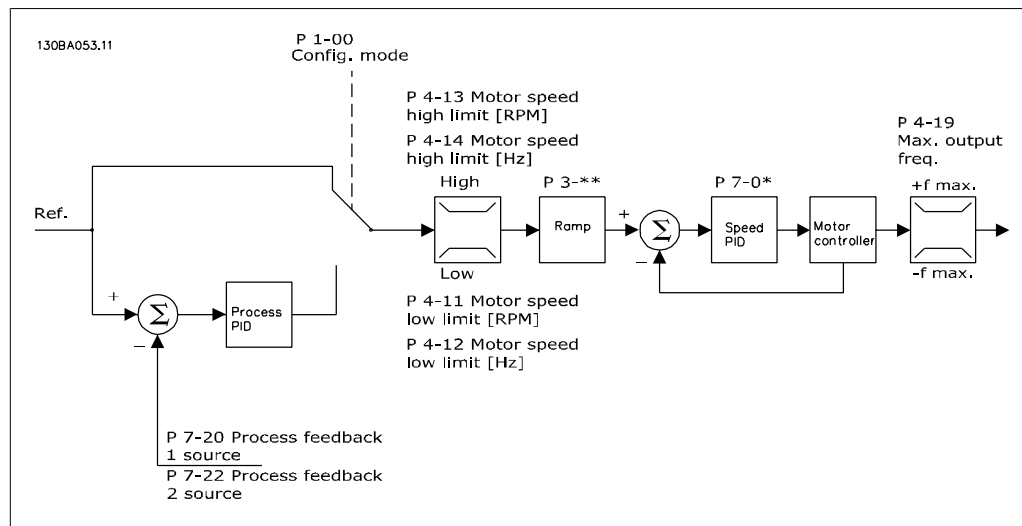

In the shown configuration, par. 1-01 *Motor Control Principle* is set to "Flux sensorless [2]" and par. 1-00 is set to "Speed open loop [0]". The resulting reference from the reference handling system is fed through the ramp and speed limitations as determined by the parameter settings indicated.

An estimated speed feedback is generated to the Speed PID to control the output frequency. The Speed PID must be set with its P,I, and D parameters (par. group 7-0\*).

Select "Process [3]" in par. 1-00 to use the process PID control for closed loop control of i.e. speed or pressure in the controlled application. The Process PID parameters are found in par. group 7-2\* and 7-3\*.

### 3.2.6. Control Structure in Flux with Motor Feedback

Control structure in Flux with motor feedback configuration (only available in FC 302):

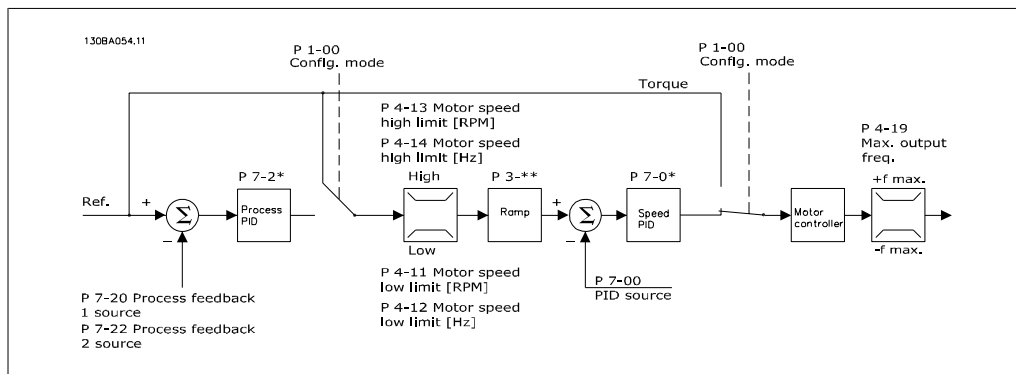

In the shown configuration, par. 1-01 *Motor Control Principle* is set to “Flux w motor feedb [3]” and par. 1-00 is set to “Speed closed loop [1]”.

The motor control in this configuration relies on a feedback signal from an encoder mounted directly on the motor (set in par. 1-02 *Motor Shaft Encoder Source*).

Select “Speed closed loop [1]” in par. 1-00 to use the resulting reference as an input for the Speed PID control. The Speed PID control parameters are located in par. group 7-0\*.

Select “Torque [2]” in par. 1-00 to use the resulting reference directly as a torque reference. Torque control can only be selected in the *Flux with motor feedback* (par. 1-01 *Motor Control Principle*) configuration. When this mode has been selected, the reference will use the Nm unit. It requires no torque feedback, since the actual torque is calculated on the basis of the current measurement of the frequency converter.

Select “Process [3]” in par. 1-00 to use the process PID control for closed loop control of e.g. speed or a process variable in the controlled application.

### 3.2.7. Internal Current Control in VVCplus Mode

The frequency converter features an integral current limit control which is activated when the motor current, and thus the torque, is higher than the torque limits set in par. 4-16, 4-17 and 4-18.

When the frequency converter is at the current limit during motor operation or regenerative operation, the frequency converter will try to get below the preset torque limits as quickly as possible without losing control of the motor.

### 3.2.8. Local (Hand On) and Remote (Auto On) Control

The frequency converter can be operated manually via the local control panel (LCP) or remotely via analog and digital inputs and serial bus.

If allowed in par. 0-40, 0-41, 0-42, and 0-43, it is possible to start and stop the frequency converter via the LCP using the [Hand ON] and [Off] keys. Alarms can be reset via the [RESET] key. After pressing the [Hand On] key, the frequency converter goes into Hand mode and follows (as default) the Local reference that can be set using arrow key on the LCP.

After pressing the [Auto On] key, the frequency converter goes into Auto mode and follows (as default) the Remote reference. In this mode, it is possible to control the frequency converter via the digital inputs and various serial interfaces (RS-485, USB, or an optional

fieldbus). See more about starting, stopping, changing ramps and parameter set-ups etc. in par. group 5-1\* (digital inputs) or par. group 8-5\* (serial communication).



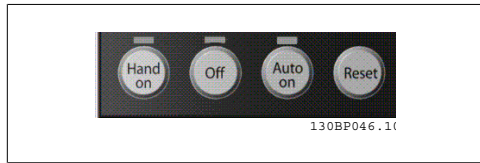

**Active Reference and Configuration Mode**

The active reference can be either the local reference or the remote reference.

In par. 3-13 *Reference Site* the local reference can be permanently selected by selecting *Local* [2].

To permanently select the remote reference select *Remote* [1]. By selecting *Linked to Hand/Auto* [0] (default) the reference site will depend on which mode is active. (Hand Mode or Auto Mode).

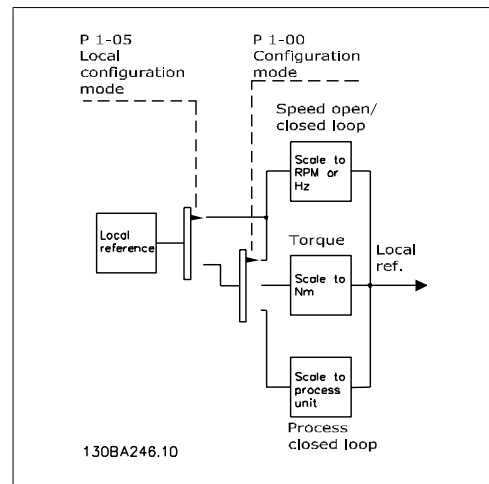
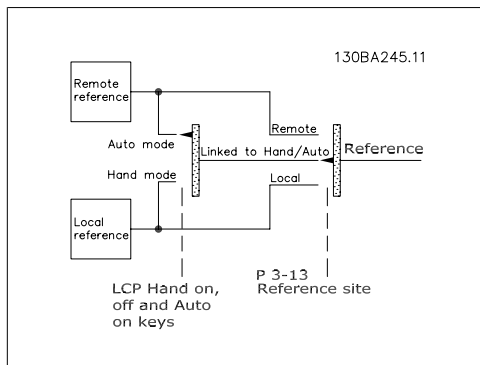

Hand On Auto LCP Keys	Reference Site Par. 3-13	Active Reference
Hand	Linked to Hand / Auto	Local
Hand -> Off	Linked to Hand / Auto	Local
Auto	Linked to Hand / Auto	Remote
Auto -> Off	Linked to Hand / Auto	Remote
All keys	Local	Local
All keys	Remote	Remote

The table shows under which conditions either the Local reference or the Remote reference is active. One of them is always active, but both can not be active at the same time.

Par. 1-00 *Configuration Mode* determines what kind of application control principle (i.e. Speed, Torque or Process Control) is used when the Remote reference is active (see table above for the conditions).

Par. 1-05 *Local Mode Configuration* determines the kind of application control principle that is used when the Local reference is made active.

**Reference Handling**

**Local Reference**

**Remote Reference**

The reference handling system for calculating the Remote reference is shown in the illustration below.

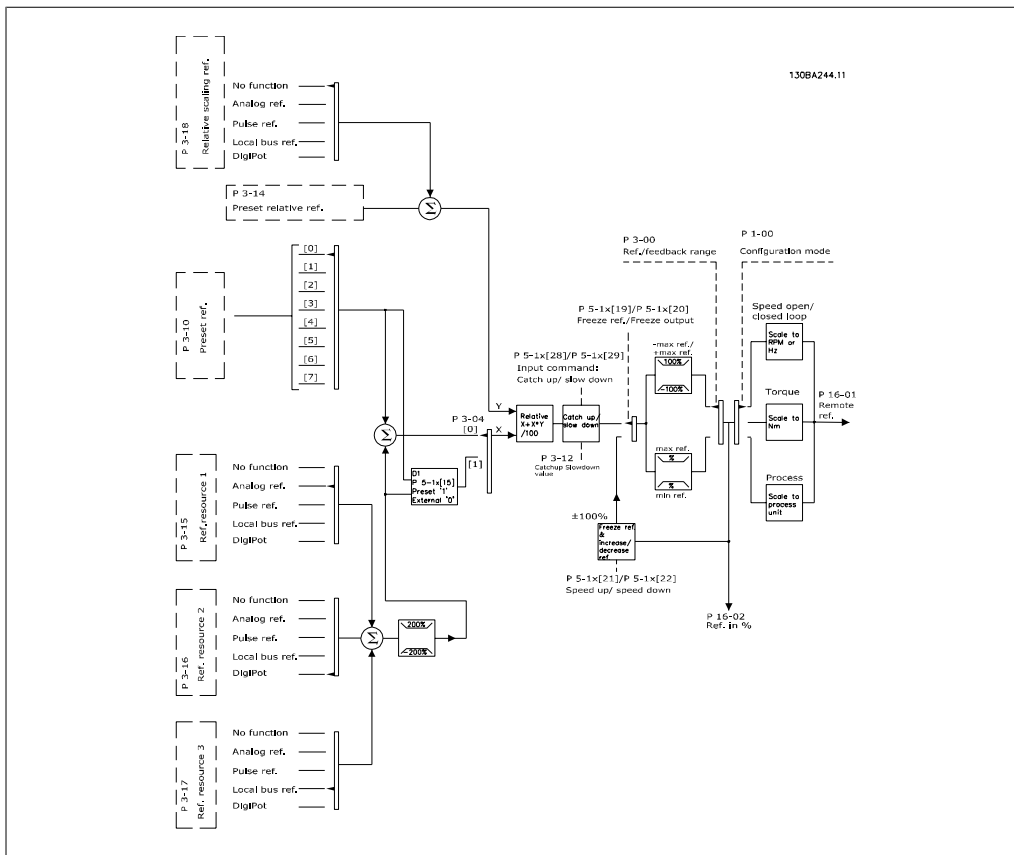

**The Remote reference is calculated once every scan interval and initially consists of two parts:**

1. X (the external reference) : A sum (see par. 3-04) of up to four externally selected references, comprising any combination (determined by the setting of par. 3-15, 3-16 and 3-17) of a fixed preset reference (par. 3-10), variable analog references, variable digital pulse references, and various serial bus references in whatever unit the frequency converter is controlled ([Hz], [RPM], [Nm] etc.).
2. Y- (the relative reference): A sum of one fixed preset reference (par. 3-14) and one variable analog reference (par. 3-18) in [%].

The two parts are combined in the following calculation: Remote reference =  $X + X * Y / 100\%$ . The *catch up / slow down* function and the *freeze reference* function can both be activated by digital inputs on the frequency converter. They are described in par. group 5-1\*.

The scaling of analog references are described in par. groups 6-1\* and 6-2\*, and the scaling of digital pulse references are described in par. group 5-5\*.

Reference limits and ranges are set in par. group 3-0\*.

### 3.2.9. Reference Handling

References and feedback can be scaled in physical units (i.e. RPM, Hz, °C) or simply in % relating to the values of par. 3-02 *Minimum Reference* and par. 3-03 *Maximum Reference*.

**In that case all analog and pulse inputs are scaled according to the following rules:**

- When par. 3-00 *Reference Range*: [0] Min - Max 0% reference equals 0 [unit] where unit can be any unit e.g. rpm, m/s, bar etc. 100% reference equals the Max (abs (par. 3-03 *Maximum Reference*), abs (par. 3-02 *Minimum Reference*)).
- When par. 3-00 *Reference Range*: [1] -Max - +Max 0% reference equals 0 [unit] -100% reference equals -Max Reference 100% reference equals Max Reference.

**Bus references are scaled according to the following rules:**

- When par. 3-00 *Reference Range*: [0] Min - Max. To obtain max resolution on the bus reference the scaling on the bus is: 0% reference equals Min Reference and 100% reference equals Max reference.
- When par. 3-00 *Reference Range*: [1] -Max - +Max -100% reference equals -Max Reference 100% reference equals Max Reference.

Par. 3-00 *Reference Range*, 3-02 *Minimum Reference* and 3-03 *Maximum Reference* together define the allowed range of the sum of all references. The sum of all references are clamped when necessary. The relation between the resulting reference (after clamping) and the sum of all references is shown below.

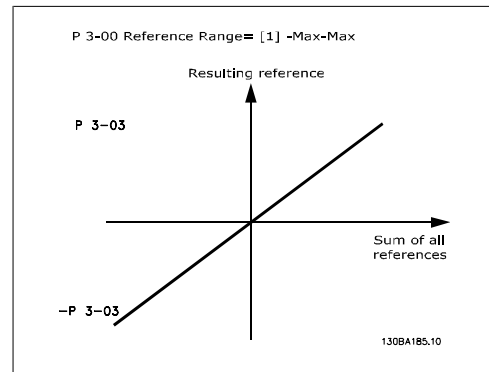
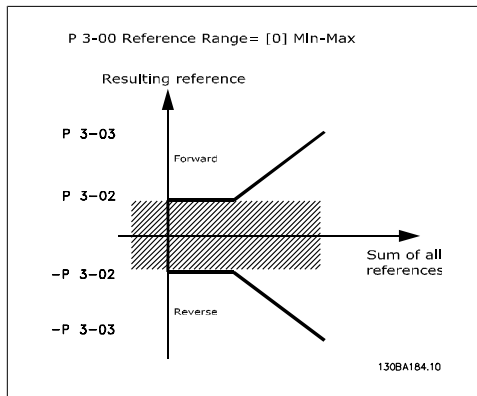

The value of par. 3-02 *Minimum Reference* can not be set to less than 0, unless the par. 1-00 *Configuration Mode* is set to [3] Process. In that case the following relations between the resulting reference (after clamping) and the sum of all references is as shown to the right.

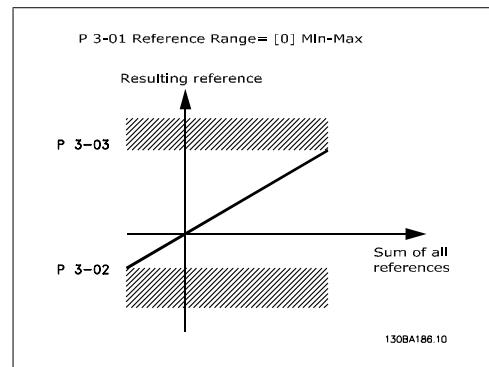

### 3.2.10. Scaling of References and Feedback

References and feedback are scaled from analog and pulse inputs in the same way. The only difference is that a reference above or below the specified minimum and maximum "endpoints" (P1 and P2 in the graph below) are clamped whereas a feedback above or below is not.

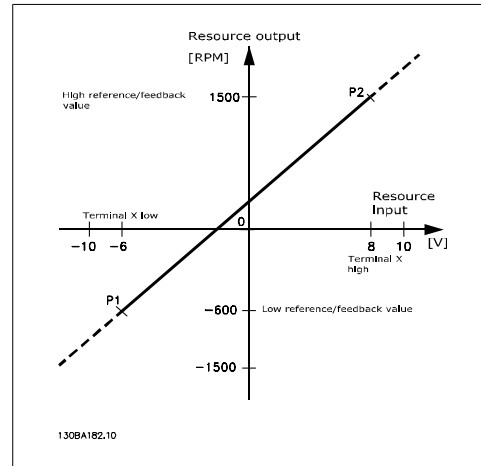
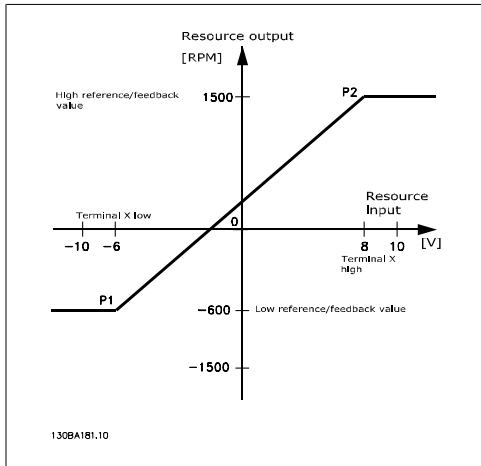

The endpoints P1 and P2 are defined by the following parameters depending on which analog or pulse input is used

	Analog 53 S201=OFF	Analog 53 S201=ON	Analog 54 S202=OFF	Analog 54 S202=ON	Pulse Input 29	Pulse Input 33
<b>P1 = (Minimum input value, Minimum reference value)</b>						
Minimum reference value	Par. 6-14	Par. 6-14	Par. 6-24	Par. 6-24	Par. 5-52	Par. 5-57
Minimum input value	Par. 6-10 [V]	Par. 6-12 [mA]	Par. 6-20 [V]	Par. 6-22 [mA]	Par. 5-50 [Hz]	Par. 5-55 [Hz]
<b>P2 = (Maximum input value, Maximum reference value)</b>						
Maximum reference value	Par. 6-15	Par. 6-15	Par. 6-25	Par. 6-25	Par. 5-53	Par. 5-58
Maximum input value	Par. 6-11 [V]	Par. 6-13 [mA]	Par. 6-21 [V]	Par. 6-23 [mA]	Par. 5-51 [Hz]	Par. 5-56 [Hz]

### 3.2.11. Dead Band Around Zero

In some cases the reference (in rare cases also the feedback) should have a Dead Band around zero (i.e. to make sure the machine is stopped when the reference is "near zero").

**To make the dead band active and to set the amount of dead band, the following settings must be done:**

- Either Minimum Reference Value (see table above for relevant parameter) or Maximum Reference Value must be zero. In other words; Either P1 or P2 must be on the X-axis in the graph below.
- And both points defining the scaling graph are in the same quadrant.

The size of the Dead Band is defined by either P1 or P2 as shown in the graph below.

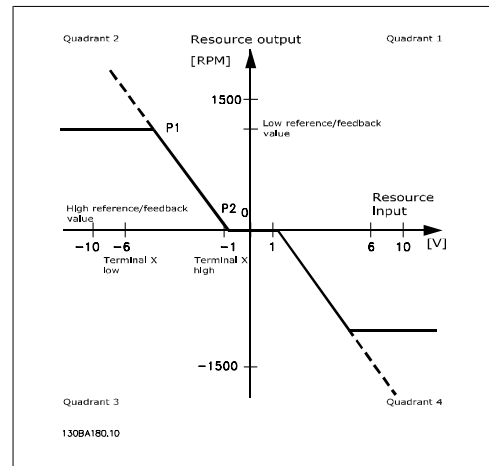
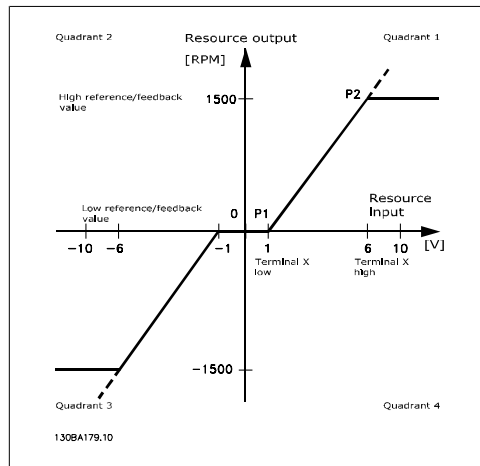

Thus a reference endpoint of P1 = (0 V, 0 RPM) will not result in any dead band, but a reference endpoint of e.g. P1 = (1V, 0 RPM) will result in a -1V to +1V dead band in this case provided that the end point P2 is placed in either Quadrant 1 or Quadrant 4.

**Case 1: Positive Reference with Dead band, Digital input to trigger reverse**

This Case shows how Reference input with limits inside Min – Max limits clamps.

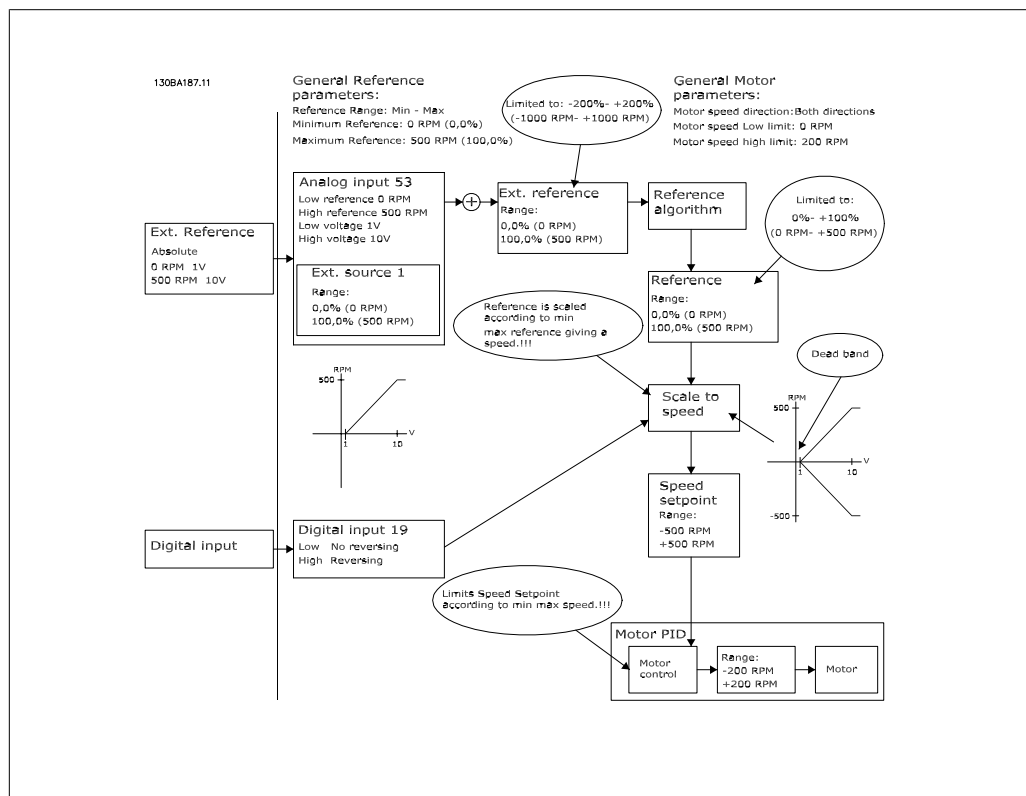

**Case 2: Positive Reference with Dead band, Digital input to trigger reverse. Clamping rules.**

This Case shows how Reference input with limits outside -Max – +Max limits clamps to the inputs low and high limits before addition to External reference. And how the External reference is clamped to -Max – +Max by the Reference algorithm.

3

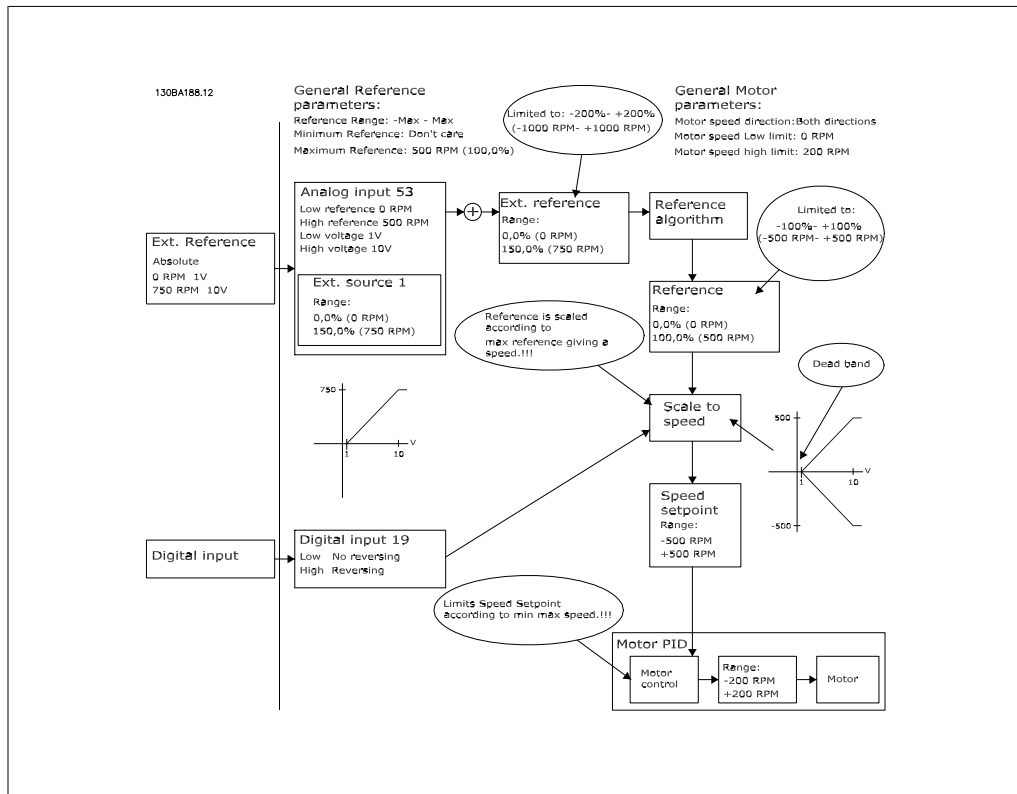

**Case 3: Negative to positive reference with dead band, Sign determines the direction, -Max - +Max**

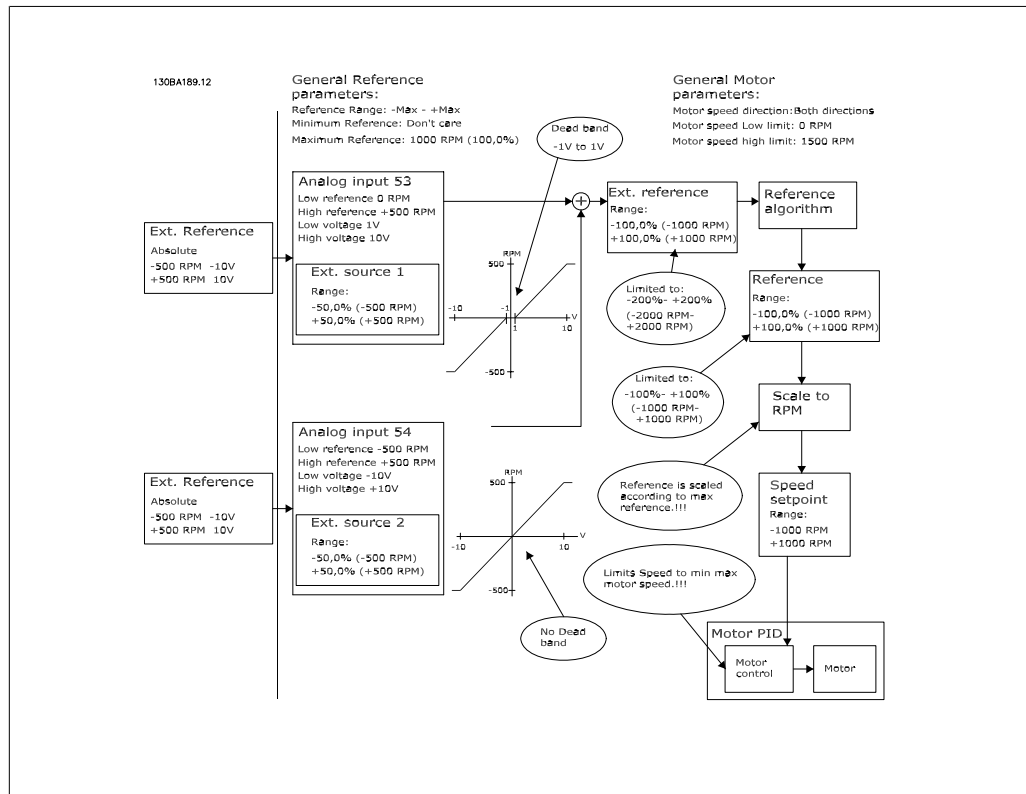

### 3.3.1. Speed PID Control

The table shows the control configurations where the Speed Control is active.

Par. 1-00 Configuration Mode	Par. 1-01 Motor Control Principle			
	U/f	VVC <sup>plus</sup>	Flux Sensorless	Flux w/ enc. feedb
[0] Speed open loop	Not Active	Not Active	ACTIVE	N.A.
[1] Speed closed loop	N.A.	ACTIVE	N.A.	ACTIVE
[2] Torque	N.A.	N.A.	N.A.	Not Active
[3] Process		Not Active	ACTIVE	ACTIVE

Note: "N.A." means that the specific mode is not available at all. "Not Active" means that the specific mode is available but the Speed Control is not active in that mode.

Note: The Speed Control PID will work under the default parameter setting, but tuning the parameters is highly recommended to optimize the motor control performance. The two Flux motor control principles are specially dependant on proper tuning to yield their full potential.

The following parameters are relevant for the Speed Control:

Parameter	Description of function										
Feedback Par. 7-00	Select from which input the Speed PID should get its feedback.										
Proportional Gain Par. 7-02	The higher the value - the quicker the control. However, too high value may lead to oscillations.										
Integral Time Par. 7-03	Eliminates steady state speed error. Lower value means quick reaction. However, too low value may lead to oscillations.										
Differentiation Time Par. 7-04	Provides a gain proportional to the rate of change of the feedback. A setting of zero disables the differentiator.										
Differentiator Gain Limit Par. 7-05	If there are quick changes in reference or feedback in a given application - which means that the error changes swiftly - the differentiator may soon become too dominant. This is because it reacts to changes in the error. The quicker the error changes, the stronger the differentiator gain is. The differentiator gain can thus be limited to allow setting of the reasonable differentiation time for slow changes and a suitably quick gain for quick changes.										
Lowpass Filter Time Par. 7-06	A low-pass filter that dampens oscillations on the feedback signal and improves steady state performance. However, too large filter time will deteriorate the dynamic performance of the Speed PID control. Practical settings of Par 7-06 taken from the number of pulses per revolution on from encoder (PPR):										
	<table border="1"> <thead> <tr> <th>Encoder PPR</th> <th>Par. 7-06</th> </tr> </thead> <tbody> <tr> <td>512</td> <td>10 ms</td> </tr> <tr> <td>1024</td> <td>5 ms</td> </tr> <tr> <td>2048</td> <td>2 ms</td> </tr> <tr> <td>4096</td> <td>1 ms</td> </tr> </tbody> </table>	Encoder PPR	Par. 7-06	512	10 ms	1024	5 ms	2048	2 ms	4096	1 ms
Encoder PPR	Par. 7-06										
512	10 ms										
1024	5 ms										
2048	2 ms										
4096	1 ms										

Below is given an example of how to programme the Speed Control:

In this case the Speed PID Control is used to maintain a constant motor speed regardless of the changing load on the motor.

coder as feedback. The feedback sensor is an encoder (1024 pulses per. revolution) connected to terminals 32 and 33.

The required motor speed is set via a potentiometer connected to terminal 53. The speed range is 0 - 1500 RPM corresponding to 0 - 10V over the potentiometer.

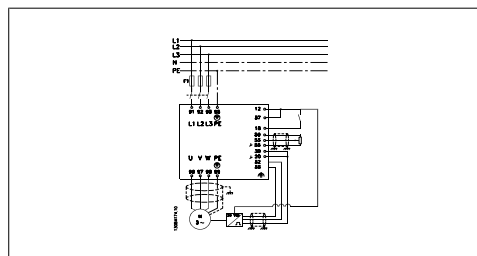

Starting and stopping is controlled by a switch connected to terminal 18.

The Speed PID monitors the actual RPM of the motor by using a 24V (HTL) incremental en-

In the parameter list below it is assumed that all other parameters and switches remain at their default setting.

The following must be programmed in order shown - see explanation of settings in the Programming Guide.



Function	Par. no.	Setting
1) Make sure the motor runs properly. Do the following:		
Set the motor parameters using name plate data	1-2*	As specified by motor name plate
Have the VLT make an Automatic Motor Adaptation	1-29	[1] Enable complete AMA
2) Check the motor is running and the encoder is attached properly. Do the following:		
Press the "Hand On" LCP key. Check that the motor is running and note in which direction it is turning (henceforth referred to as the "positive direction").		Set a <b>positive</b> reference.
Go to par. 16-20. Turn the motor slowly in the positive direction. It must be turned so slowly (only a few RPM) that it can be determined if the value in par. 16-20 is increasing or decreasing.	16-20	N.A. (read-only parameter) Note: An increasing value overflows at 65535 and starts again at 0.
If par. 16-20 is decreasing then change the encoder direction in par. 5-71.	5-71	[1] Counter clockwise (if par. 16-20 is decreasing)
3) Make sure the drive limits are set to safe values		
Set acceptable limits for the references.	3-02 3-03	0 RPM (default) 1500 RPM (default)
Check that the ramp settings are within drive capabilities and allowed application operating specifications.	3-41 3-42	default setting default setting
Set acceptable limits for the motor speed and frequency.	4-11 4-13 4-19	0 RPM (default) 1500 RPM (default) 60 Hz (default 132 Hz)
4) Configure the Speed Control and select the Motor Control principle		
Activation of Speed Control	1-00	[1] Speed closed loop
Selection of Motor Control Principle	1-01	[3] Flux w motor feedb
5) Configure and scale the reference to the Speed Control		
Set up Analog Input 53 as a reference Source	3-15	Not necessary (default)
Scale Analog Input 53 0 RPM (0 V) to 1500 RPM (10V)	6-1*	Not necessary (default)
6) Configure the 24V HTL encoder signal as feedback for the Motor Control and the Speed Control		
Set up digital input 32 and 33 as encoder inputs	5-14 5-15	[0] No operation (default)
Choose terminal 32/33 as motor feedback	1-02	Not necessary (default)
Choose terminal 32/33 as Speed PID feedback	7-00	Not necessary (default)
7) Tune the Speed Control PID parameters		
Use the tuning guidelines when relevant or tune manually	7-0*	See the guidelines below
8) Finished!		
Save the parameter setting to the LCP for safe keeping	0-50	[1] All to LCP

### 3.3.2. Tuning PID Speed Control

The following tuning guidelines are relevant when using one of the Flux motor control principles in applications where the load is mainly inertial (with a low amount of friction).

The value of par. 7-02 Proportional Gain is dependent on the combined inertia of the motor and load, and the selected bandwidth can be calculated using the following formula:

$$Par. 7 - 02 = \frac{Total\ inertia\ [kgm^2] \times Par. 1 - 25}{Par. 1 - 20 \times 9550} \times Bandwidth\ [rad / s]$$

Note: Par. 1-20 is the motor power in [kW] (i.e. enter '4' kW instead of '4000' W in the formula). A practical value for the Bandwidth is 20 rad/s. Check the result of the par. 7-02 calculation against the following formula (not required if you are using a high resolution feedback such as a SinCos feedback):

$$Par. 7-02_{MAXIMUM} = \frac{0.01 \times 4 \times Encoder Resolution \times par. 7-06}{2 \times \pi} \times Max torque ripple [\%]$$

A good start value for par. 7-06 *Speed Filter Time* is 5 ms (lower encoder resolution calls for a higher filter value). Typically a Max Torque Ripple of 3 % is acceptable. For incremental encoders the Encoder Resolution is found in either par. 5-70 (24V HTL on standard drive) or par. 17-11 (5V TTL on MCB102 Option).

Generally the practical maximum limit of par. 7-02 is determined by the encoder resolution and the feedback filter time but other factors in the application might limit the par. 7-02 *Proportional Gain* to a lower value.

To minimize the overshoot, par. 7-03 *Integral Time* could be set to approx. 2.5 s (varies with the application).

Par. 7-04 *Differential Time* should be set to 0 until everything else is tuned. If necessary finish the tuning by experimenting with small increments of this setting.

### 3.3.3. Process PID Control

The Process PID Control can be used to control application parameters that can be measured by a sensor (i.e. pressure, temperature, flow) and be affected by the connected motor through a pump, fan or otherwise.

The table shows the control configurations where the Process Control is possible. When a Flux Vector motor control principle is used, take care also to tune the Speed Control PID parameters. Refer to the section about the Control Structure to see where the Speed Control is active.

Par. 1-00 Configuration Mode	Par. 1-01 Motor Control Principle			
	U/f	VVC <sup>plus</sup>	Flux Sensorless	Flux w/ enc. feedb
[3] Process	N.A.	Process	Process & Speed	Process & Speed

Note: The Process Control PID will work under the default parameter setting, but tuning the parameters is highly recommended to optimise the application control performance. The two Flux motor control principles are specially dependant on proper Speed Control PID tuning (prior to tuning the Process Control PID) to yield their full potential.

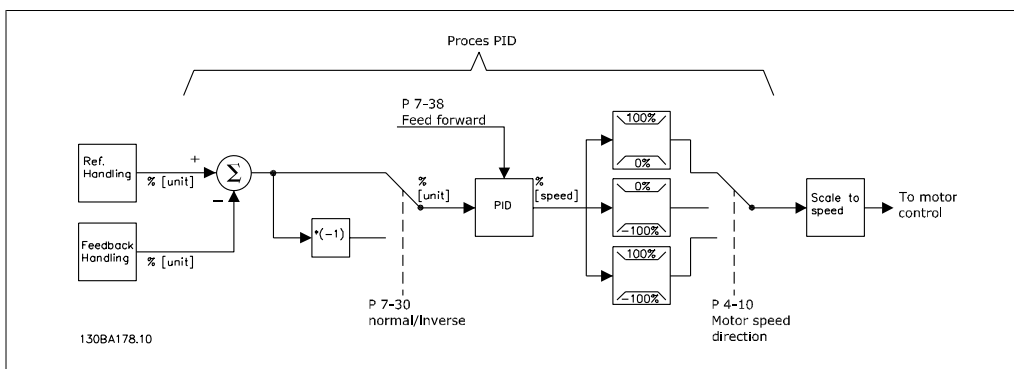

Illustration 3.1: Process PID Control diagram

The following parameters are relevant for the Process Control

Parameter	Description of function
Feedback 1 Source Par. 7-20	Select from which Source (i.e. analog or pulse input) the Process PID should get its feedback
Feedback 2 Source Par. 7-22	Optional: Determine if (and from where) the Process PID should get an additional feedback signal. If an additional feedback source is selected the two feedback signals will be added together before being used in the Process PID Control.
Normal/inverse control Par. 7-30	Under [0] Normal operation the Process Control will respond with an increase of the motor speed if the feedback is getting lower than the reference. In the same situation, but under [1] Inverse operation, the Process Control will respond with a decreasing motor speed instead.
Anti Windup Par. 7-31	The anti windup function ensures that when either a frequency limit or a torque limit is reached, the integrator will be set to a gain that corresponds to the actual frequency. This avoids integrating on an error that cannot in any case be compensated for by means of a speed change. This function can be disabled by selecting [0] "Off".
Control Start Value Par. 7-32	In some applications, reaching the required speed/set point can take a very long time. In such applications it might be an advantage to set a fixed motor speed from the frequency converter before the process control is activated. This is done by setting a Process PID Start Value (speed) in par. 7-32.
Proportional Gain Par. 7-33	The higher the value - the quicker the control. However, too large value may lead to oscillations.
Integral Time Par. 7-34	Eliminates steady state speed error. Lower value means quick reaction. However, too small value may lead to oscillations.
Differentiation Time Par. 7-35	Provides a gain proportional to the rate of change of the feedback. A setting of zero disables the differentiator.
Differentiator Gain Limit Par. 7-36	If there are quick changes in reference or feedback in a given application - which means that the error changes swiftly - the differentiator may soon become too dominant. This is because it reacts to changes in the error. The quicker the error changes, the stronger the differentiator gain is. The differentiator gain can thus be limited to allow setting of the reasonable differentiation time for slow changes.
Feed Forward Factor Par. 7-38	In application where there is a good (and approximately linear) correlation between the process reference and the motor speed necessary for obtaining that reference, the Feed Forward Factor can be used to achieve better dynamic performance of the Process PID Control.
Lowpass Filter Time Par. 5-54 (Pulse term. 29), Par. 5-59 (Pulse term. 33), Par. 6-16 (Analog term 53), Par. 6-26 (Analog term. 54)	<p>If there are oscillations of the current/voltage feedback signal, these can be dampened by means of a low-pass filter. This time constant represents the speed limit of the ripples occurring on the feedback signal.</p> <p>Example: If the low-pass filter has been set to 0.1s, the limit speed will be 10 RAD/sec. (the reciprocal of 0.1 s), corresponding to <math>(10/(2 \times \pi)) = 1.6</math> Hz. This means that all currents/voltages that vary by more than 1.6 oscillations per second will be damped by the filter. The control will only be carried out on a feedback signal that varies by a frequency (speed) of less than 1.6 Hz.</p> <p>The low-pass filter improves steady state performance but selecting a too large filter time will deteriorate the dynamic performance of the Process PID Control.</p>

### 3.3.4. Example of Process PID Control

The following is an example of a Process PID Control used in a ventilation system:

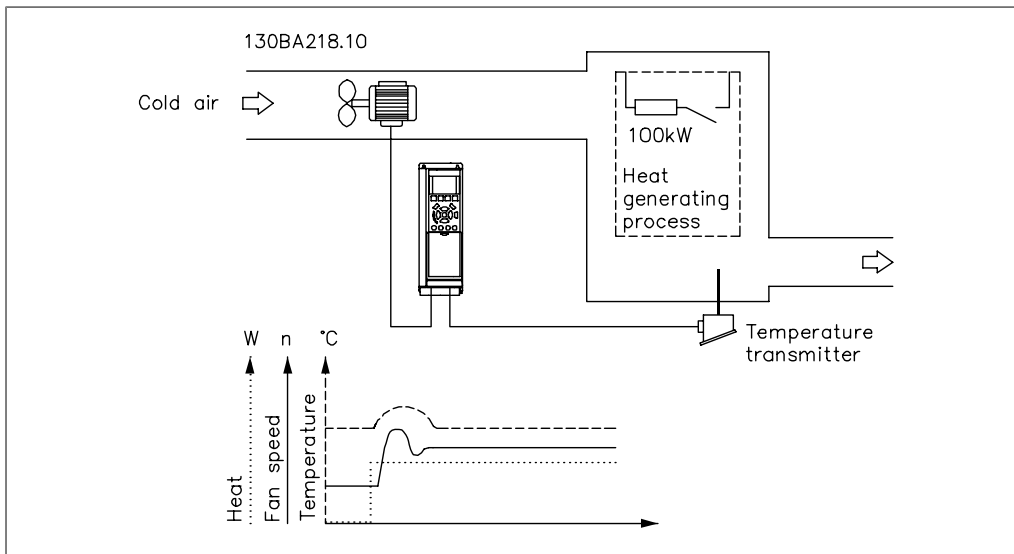

In a ventilation system, the temperature is to be settable from - 5 - 35°C with a potentiometer of 0-10 Volt. The set temperature must be kept constant, for which purpose the Process Control is to be used.

The control is of the inverse type, which means that when the temperature increases, the ventilation speed is increased as well, so as to generate more air. When the temperature drops, the speed is reduced. The transmitter used is a temperature sensor with a working range of -10-40°C, 4-20 mA. Min. / Max. speed 300 / 1500 RPM.

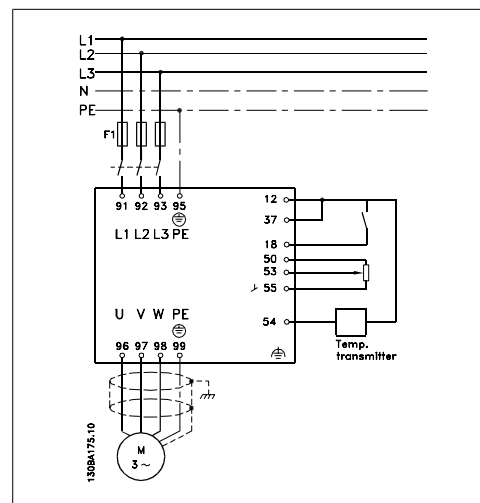
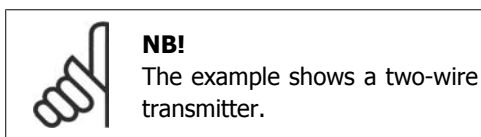

1. Start/Stop via switch connected to terminal 18.
2. Temperature reference via potentiometer (-5-35°C, 0-10 VDC) connected to terminal 53.
3. Temperature feedback via transmitter (-10-40°C, 4-20 mA) connected to terminal 54. Switch S202 set to ON (current input).

Example of Process PID Control set-up

Function	Par. no.	Setting
Initialize the frequency converter	14-22	[2] Initialization - make a power cycling - press reset
1) Set motor parameters:		
Set the motor parameters according to name plate data	1-2*	As stated on motor name plate
Perform a full Automation Motor Adaptation	1-29	[1] Enable complete AMA
2) Check that motor is running in the right direction. When motor is connected to frequency converter with straight forward phase order as U - U; V- V; W - W motor shaft usually turns clockwise seen into shaft end.		
Press "Hand On" LCP key. Check shaft direction by applying a manual reference.		
If motor turns opposite of required direction: 1. Change motor direction in par. 4-10 2. Turn off mains - wait for DC link to discharge - switch two of the motor phases	4-10	Select correct motor shaft direction
Set configuration mode	1-00	[3] Process
Set Local Mode Configuration	1-05	[0] Speed Open Loop
3) Set reference configuration, ie. the range for reference handling. Set scaling of analog input in par. 6-xx		
Set reference/feedback units	3-01	[60] ° C Unit shown on display
Set min. reference (10° C)	3-02	-5° C
Set max. reference (80° C)	3-03	35° C
If set value is determined from a preset value (array parameter), set other reference sources to No Function	3-10	[0] 35% $Ref = \frac{p3 - 10_{(0)}}{100} \times ((p3 - 03) - (p3 - 02)) = 24, 5^{\circ} C$ Par. 3-14 to par. 3-18 [0] = No Function
4) Adjust limits for the frequency converter:		
Set ramp times to an appropriate value as 20 sec.	3-41	20 sec.
	3-42	20 sec.
Set min. speed limits	4-11	300 RPM
Set motor speed max. limit	4-13	1500 RPM
Set max. output frequency	4-19	60 Hz
Set S201 or S202 to wanted analog input function (Voltage (V) or milli-Amps (I)) NOTE! Switches are sensitive - Make a power cycling keeping default setting of V		
5) Scale analog inputs used for reference and feedback		
Set terminal 53 low voltage	6-10	0 V
Set terminal 53 high voltage	6-11	10 V
Set terminal 54 low feedback value	6-24	-5° C
Set terminal 54 high feedback value	6-25	35° C
Set feedback source	7-20	[2] Analog input 54
6) Basic PID settings		
Process PID Normal/Inverse	7-30	[0] Normal
Process PID Anti Wind-up	7-31	[1] On
Process PID start speed	7-37	300 rpm
Save parameters to LCP	0-50	[1] All to LCP

### Optimisation of the process regulator

The basic settings have now been made; all that needs to be done is to optimise the proportional gain, the integration time and the differentiation time (par. 7-33, 7-34, 7-35). In most processes, this can be done by following the guidelines given below.

1. Start the motor
2. Set par. 7-33 (*Proportional Gain*) to 0.3 and increase it until the feedback signal again begins to vary continuously. Then reduce the value until the feedback signal has stabilised. Now lower the proportional gain by 40-60%.

3. Set par. 7-34 (Integration Time) to 20 sec. and reduce the value until the feedback signal again begins to vary continuously. Increase the integration time until the feedback signal stabilises, followed by an increase of 15-50%.
4. Only use par. 7-35 for very fast-acting systems only (differentiation time). The typical value is four times the set integration time. The differentiator should only be used when the setting of the proportional gain and the integration time has been fully optimised. Make sure that oscillations on the feedback signal is sufficiently dampened by the lowpass filter on the feedback signal.

**NB!**  
If necessary, start/stop can be activated a number of times in order to provoke a variation of the feedback signal.

### 3.3.5. Ziegler Nichols Tuning Method

In order to tune the PID controls of the frequency converter, several tuning methods can be used. One approach is to use a technique which was developed in the 1950s but which has stood the test of time and is still used today. This method is known as the Ziegler Nichols tuning method.

**NB!**  
The method described must not be used on applications that could be damaged by the oscillations created by marginally stable control settings.

The criteria for adjusting the parameters are based on evaluating the system at the limit of stability rather than on taking a step response. We increase the proportional gain until we observe continuous oscillations (as measured on the feedback), that is, until the system becomes marginally stable. The corresponding gain ( $K_U$ ) is called the ultimate gain. The period of the oscillation ( $P_U$ ) (called the ultimate period) is determined as shown in Figure 1.

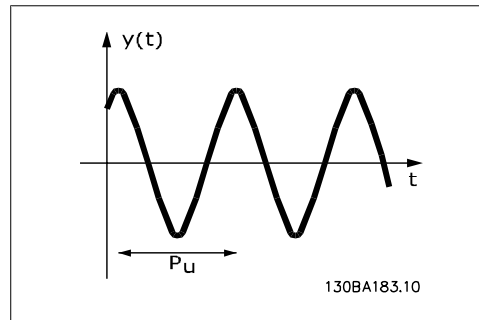

Illustration 3.2: **Figure 1: Marginally stable system**

$P_U$  should be measured when the amplitude of oscillation is quite small. Then we "back off" from this gain again, as shown in Table 1.

$K_U$  is the gain at which the oscillation is obtained.

Type of Control	Proportional Gain	Integral Time	Differentiation Time
PI-control	$0.45 * K_U$	$0.833 * P_U$	-
PID tight control	$0.6 * K_U$	$0.5 * P_U$	$0.125 * P_U$
PID some overshoot	$0.33 * K_U$	$0.5 * P_U$	$0.33 * P_U$

Table 1: Ziegler Nichols tuning for regulator, based on a stability boundary.

Experience has shown that the control setting according to Ziegler Nichols rule provides a good closed loop response for many systems. The process operator can do the final tuning of the control iteratively to yield satisfactory control.

**Step-by-step Description:**

**Step 1:** Select only Proportional Control, meaning that the Integral time is selected to the maximum value, while the differentiation time is selected to zero.

**Step 2:** Increase the value of the proportional gain until the point of instability is reached (sustained oscillations) and the critical value of gain,  $K_u$ , is reached.

**Step 3:** Measure the period of oscillation to obtain the critical time constant,  $P_u$ .

**Step 4:** Use the table above to calculate the necessary PID control parameters.

**3.4.1. General Aspects of EMC Emissions**

Electrical interference is usually conducted at frequencies in the range 150 kHz to 30 MHz. Airborne interference from the drive system in the range 30 MHz to 1 GHz is generated from the inverter, motor cable, and the motor.

As shown in the illustration below, capacitive currents in the motor cable coupled with a high  $dV/dt$  from the motor voltage generate leakage currents.

The use of a screened motor cable increases the leakage current (see illustration below) because screened cables have higher capacitance to earth than unscreened cables. If the leakage current is not filtered, it will cause greater interference on the mains in the radio frequency range below approx. 5 MHz. Since the leakage current ( $I_1$ ) is carried back to the unit through the screen ( $I_3$ ), there will in principle only be a small electro-magnetic field ( $I_4$ ) from the screened motor cable according to the below figure.

The screen reduces the radiated interference but increases the low-frequency interference on the mains. The motor cable screen must be connected to the frequency converter enclosure as well as on the motor enclosure. This is best done by using integrated screen clamps so as to avoid twisted screen ends (pigtailed). These increase the screen impedance at higher frequencies, which reduces the screen effect and increases the leakage current ( $I_4$ ).

If a screened cable is used for Fieldbus, relay, control cable, signal interface and brake, the screen must be mounted on the enclosure at both ends. In some situations, however, it will be necessary to break the screen to avoid current loops.

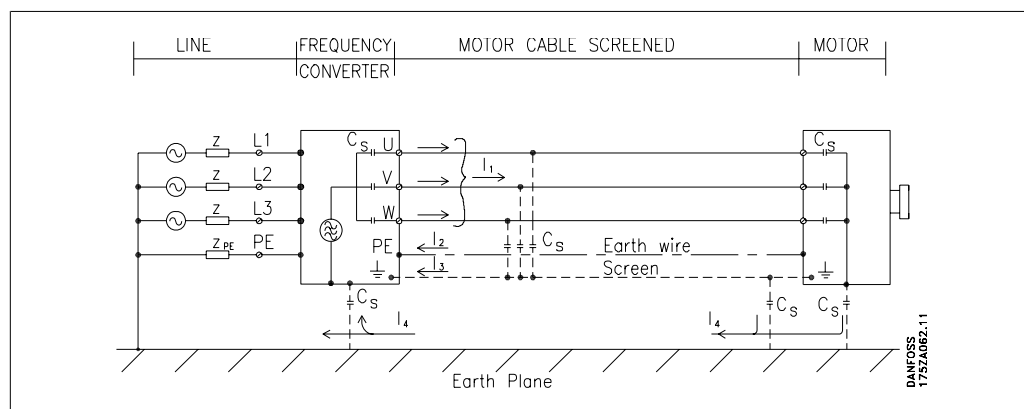

If the screen is to be placed on a mounting plate for the frequency converter, the mounting plate must be made of metal, because the screen currents have to be conveyed back to the unit. Moreover, ensure good electrical contact from the mounting plate through the mounting screws to the frequency converter chassis.

**NB!**

When unscreened cables are used, some emission requirements are not complied with, although the immunity requirements are observed.

In order to reduce the interference level from the entire system (unit + installation), make motor and brake cables as short as possible. Avoid placing cables with a sensitive signal level alongside motor and brake cables. Radio interference higher than 50 MHz (airborne) is especially generated by the control electronics.

The following test results have been obtained using an application with a frequency converter (with options if relevant), a screened control cable, a control box with potentiometer, as well as a motor and a screened motor cable.

	Conducted emission			Radiated emission	
	Industrial environment	Housing, trades and light industries	Housing, trades and light industries	Industrial environment	Housing, trades and light industries
Setup	EN 55011 Class A2	EN 55011 Class A1	EN 55011 Class B	EN 55011 Class A1	EN 55011 Class B
FC 301/FC 302 (H2)					
0-3.7 kW 200-240 V	5 m	No	No	No	No
0-7.5 kW 380-480/500 V	5 m	No	No	No	No
FC 301 (H1)					
0-3.7 kW 200-240 V	75 m	50 m	10 m	Yes	No
0-7.5 kW 380-480 V	75 m	50 m	10 m	Yes	No
FC 301 (H3)					
0-1.5 kW 200-240 V	50 m	25 m	2.5 m	Yes	No
0-1.5 kW 380-480 V	50 m	25 m	2.5 m	Yes	No
FC 302 (H1)					
0-3.7 kW 200-240 V	150 m	150 m	50 m	Yes	No
0-7.5 kW 380-500 V	150 m	150 m	50 m	Yes	No
FC 301/FC 302 (H2)					
11-22 kW 380-480/500 V	25 m	No	No	No	No
FC 301 (H1)					
11-22 kW 380-480 V	75 m	50 m	10 m	Yes	No
FC 302 (H1)					
11-22 kW 380-500 V	150 m	150 m	50 m	Yes	No
FC 302 (HX)					
0.75 - 7.5 kW 550 - 600 V	No	No	No	No	No

Table 3.1: EMC Test Results (Emission, Immunity)

HX, H1, H2 or H3 is defined in the type code pos. 16 - 17 for EMC filters

HX - No EMC filters build in the frequency converter (600 V units only)

H1 - Integrated EMC filter. Fulfil Class A1/B

H2 - No additional EMC filter. Fulfil Class A2

H3 - Integrated EMC filter. Fulfil class A1/B (Enclosure type A1 only)



### 3.4.2. Required Compliance Levels

Standard / environment	Housing, trades, and light industries		Industrial environment	
	Conducted	Radiated	Conducted	Radiated
IEC 61000-6-3 (generic)	Class B	Class B		
IEC 61000-6-4			Class A1	Class A1
EN 61800-3 (restricted)	Class A1	Class A1	Class A1	Class A1
EN 61800-3 (unrestricted)	Class B	Class B	Class A2	Class A2

EN 55011:	Threshold values and measuring methods for radio interference from industrial, scientific and medical (ISM) high-frequency equipment.
Class A1:	Equipment used in a public supply network. Restricted distribution.
Class A2:	Equipment used in a public supply network.
Class B1:	Equipment used in areas with a public supply network (dwellings, commerce, and light industries). Unrestricted distribution.

### 3.4.3. EMC Immunity

In order to document immunity against electrical interference from electrical phenomena, the following immunity tests have been made on a system consisting of a frequency converter (with options, if relevant), a screened control cable, and a control box with potentiometer, motor cable, and motor.

**The tests were performed in accordance with the following basic standards:**

- **EN 61000-4-2 (IEC 61000-4-2): Electrostatic discharges (ESD)** Simulation of electrostatic discharges from human beings.
- **EN 61000-4-3 (IEC 61000-4-3): Incoming electromagnetic field radiation, amplitude modulated** Simulation of the effects of radar and radio communication equipment as well as mobile communications.
- **EN 61000-4-4 (IEC 61000-4-4): Burst transients** Simulation of interference brought about by switching with a contactor, relays, or similar devices.
- **EN 61000-4-5 (IEC 61000-4-5): Surge transients** Simulation of transients brought e.g. by lightning that strikes near installations.
- **EN 61000-4-6 (IEC 61000-4-6): RF Common mode** Simulation of the effect from radio-transmitting equipment connected to connection cables.

See following EMC immunity form.

FC 301/FC 302; 200-240 V, 380-500 V					
Basic standard	Burst IEC 61000-4-4	Surge IEC 61000-4-5	ESD IEC 61000-4-2	Radiated electromagnetic field IEC 61000-4-3	RF common mode voltage IEC 61000-4-6
Acceptance criterion	B	B	B	A	A
Line	4 kV CM	2 kV/2 Ω DM 4 kV/12 Ω CM	—	—	10 V <sub>RMS</sub>
Motor	4 kV CM	4 kV/2 Ω <sup>1)</sup>	—	—	10 V <sub>RMS</sub>
Brake	4 kV CM	4 kV/2 Ω <sup>1)</sup>	—	—	10 V <sub>RMS</sub>
Load sharing	4 kV CM	4 kV/2 Ω <sup>1)</sup>	—	—	10 V <sub>RMS</sub>
Control wires	2 kV CM	2 kV/2 Ω <sup>1)</sup>	—	—	10 V <sub>RMS</sub>
Standard bus	2 kV CM	2 kV/2 Ω <sup>1)</sup>	—	—	10 V <sub>RMS</sub>
Relay wires	2 kV CM	2 kV/2 Ω <sup>1)</sup>	—	—	10 V <sub>RMS</sub>
Application and Fieldbus options	2 kV CM	2 kV/2 Ω <sup>1)</sup>	—	—	10 V <sub>RMS</sub>
LCP cable	2 kV CM	2 kV/2 Ω <sup>1)</sup>	—	—	10 V <sub>RMS</sub>
External 24 V DC	2 kV CM	0.5 kV/2 Ω DM 1 kV/12 Ω CM	—	—	10 V <sub>RMS</sub>
Enclosure	—	—	8 kV AD 6 kV CD	10 V/m	—

AD: Air Discharge  
CD: Contact Discharge  
CM: Common mode  
DM: Differential mode  
1. Injection on cable shield.

Table 3.2: Immunity continued

PELV offers protection by way of extra low voltage. Protection against electric shock is ensured when the electrical supply is of the PELV type and the installation is made as described in local/national regulations on PELV supplies.

All control terminals and relay terminals 01-03/04-06 comply with PELV (Protective Extra Low Voltage) (Does not apply to 525-600 V units and at grounded Delta leg above 300 V).

Galvanic (ensured) isolation is obtained by fulfilling requirements for higher isolation and by providing the relevant creepage/clearance distances. These requirements are described in the EN 61800-5-1 standard.

The components that make up the electrical isolation, as described below, also comply with the requirements for higher isolation and the relevant test as described in EN 61800-5-1.

The PELV galvanic isolation can be shown in six locations (see illustration):

In order to maintain PELV all connections made to the control terminals must be PELV, e.g. thermostat must be reinforced/double insulated.

1. Power supply (SMPS) incl. signal isolation of  $U_{DC}$ , indicating the intermediate current voltage.
2. Gate drive that runs the IGBTs (trigger transformers/opto-couplers).
3. Current transducers.
4. Opto-coupler, brake module.
5. Internal inrush, RFI, and temperature measurement circuits.
6. Custom relays.

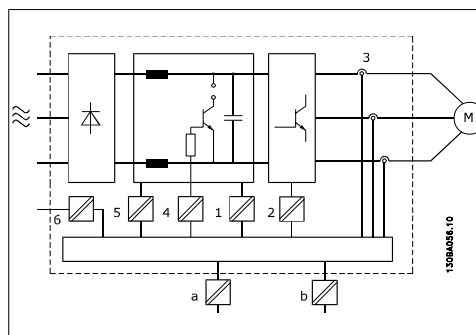



Illustration 3.3: Galvanic isolation

The functional galvanic isolation (a and b on drawing) is for the 24 V back-up option and for the RS 485 standard bus interface.



By altitudes above 2 km, please contact Danfoss Drives regarding PELV.

### 3.6.1. Earth Leakage Current



**Warning:**  
 Touching the electrical parts may be fatal - even after the equipment has been disconnected from mains.  
 Also make sure that other voltage inputs have been disconnected, such as load sharing (linkage of DC intermediate circuit), as well as the motor connection for kinetic back-up.  
 Using VLT AutomationDrive FC 300: wait at least the amount of time indicated in the *Safety Precautions*-section.  
 Shorter time is allowed only if indicated on the nameplate for the specific unit.



**Leakage Current**  
 The earth leakage current from the FC 300 exceeds 3.5 mA. To ensure that the earth cable has a good mechanical connection to the earth connection (terminal 95), the cable cross section must be at least 10 mm<sup>2</sup> or 2 rated earth wires terminated separately.

**Residual Current Device**  
 This product can cause a d.c. current in the protective conductor. Where a residual current device (RCD) is used for extra protection, only an RCD of Type B (time delayed) shall be used on the supply side of this product. See also RCD Application Note MN.90.GX.02.  
 Protective earthing of the frequency converter and the use of RCD's must always follow national and local regulations.

### 3.7.1. Selection of Brake Resistor

To handle higher demands by generatoric braking a brake resistor is necessary. Using a brake resistor ensures that the energy is absorbed in the brake resistor and not in the frequency converter.

If the amount of kinetic energy transferred to the resistor in each braking period is not known, the average power can be calculated on the basis of the cycle time and braking time also called intermitted duty cycle. The resistor intermitted duty cycle is an indication of the duty cycle at which the resistor is active. The below figure shows a typical braking cycle.



**NB!**  
 Motor suppliers often use S5 when stating the permissible load which is an expression of intermitted duty cycle.

The intermitted duty cycle for the resistor is calculated as follows:

$$\text{Duty cycle} = t_b/T$$

T = cycle time in seconds

t<sub>b</sub> is the braking time in seconds (of the cycle time)

3

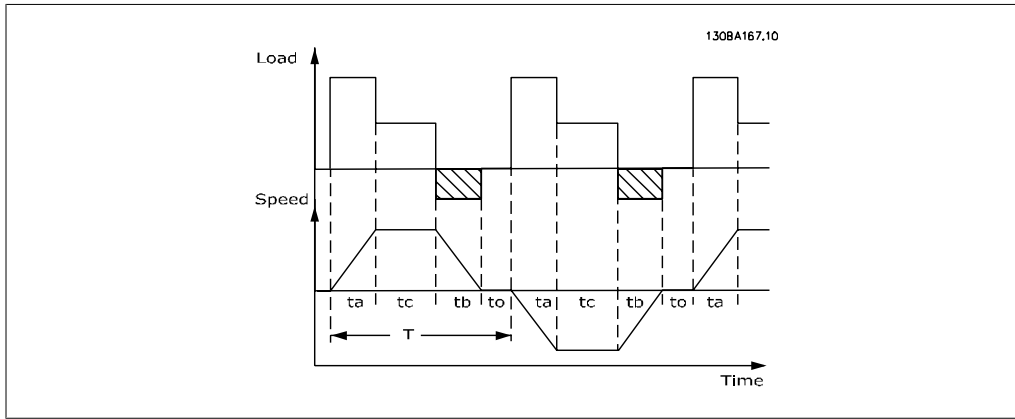

Danfoss offers brake resistors with duty cycle of 5%, 10% and 40%. If a 10% duty cycle is applied, the brake resistors are able to absorb brake power for 10% of the cycle time. The remaining 90% of the cycle time will be used on dissipating excess heat.

The max. permissible load on the brake resistor is stated as a peak power at a given intermittent duty cycle and can be calculated as:

The brake resistance is calculated as shown:

$$R_{br} [\Omega] = \frac{U_{dc}^2}{P_{peak}}$$

where

$$P_{peak} = P_{motor} \times M_{br} \times \eta_{motor} \times \eta_{VLT} [W]$$

As can be seen, the brake resistance depends on the intermediate circuit voltage ( $U_{dc}$ ). The FC 301 and FC 302 brake function is settled in 4 areas of mains:

Size	Brake active	Warning out	before cut out (trip)
FC 301 / 302 3 x 200-240 V	390 V (UDC)	405 V	410 V
FC 301 3 x 380-480 V	778 V	810 V	820 V
FC 302 3 x 380-500 V	810 V	840 V	850 V
FC 302 3 x 525-600 V	943 V	965 V	975 V

**NB!** Check that the brake resistor can cope with a voltage of 410 V, 820 V, 850 V or 975 V - unless Danfoss brake resistors are used.

Danfoss recommends the brake resistance  $R_{rec}$ , i.e. one that guarantees that the frequency converter is able to brake at the highest braking torque ( $M_{br(\%)}$ ) of 160%. The formula can be written as:

$$R_{rec} [\Omega] = \frac{U_{dc}^2 \times 100}{P_{motor} \times M_{br} (\%) \times \eta_{VLT} \times \eta_{motor}}$$

$\eta_{motor}$  is typically at 0.90

$\eta_{VLT}$  is typically at 0.98

For 200 V, 480 V, 500 V and 600 V frequency converters,  $R_{rec}$  at 160% braking torque is written as:

$$200V : R_{rec} = \frac{107780}{P_{motor}} [\Omega]$$

$$480V : R_{rec} = \frac{375300}{P_{motor}} [\Omega] \quad 1)$$

$$480V : R_{rec} = \frac{428914}{P_{motor}} [\Omega] \quad 2)$$

$$500V : R_{rec} = \frac{464923}{P_{motor}} [\Omega]$$

$$600V : R_{rec} = \frac{630137}{P_{motor}} [\Omega]$$

$$690V : R_{rec} = \frac{832664}{P_{motor}} [\Omega]$$

1) For FC 300 frequency converters  $\leq 7.5$  kW shaft output

2) For FC 300 frequency converters  $> 7.5$  kW shaft output

**NB!**

The resistor brake circuit resistance selected should not be higher than that recommended by Danfoss. If a brake resistor with a higher ohmic value is selected, the 160% braking torque may not be achieved because there is a risk that the frequency converter cuts out for safety reasons.

**NB!**

If a short circuit in the brake transistor occurs, power dissipation in the brake resistor is only prevented by using a mains switch or contactor to disconnect the mains for the frequency converter. (The contactor can be controlled by the frequency converter).

**NB!**

Do not touch the brake resistor as it can get very hot while/after braking.

### 3.7.2. Control with Brake Function

The brake is to limit the voltage in the intermediate circuit when the motor acts as a generator. This occurs, for example, when the load drives the motor and the power accumulates on the DC link. The brake is built up as a chopper circuit with the connection of an external brake resistor.

**Placing the brake resistor externally offers the following advantages:**

- The brake resistor can be selected on the basis of the application in question.
- The brake energy can be dissipated outside the control panel, i.e. where the energy can be utilized.
- The electronics of the frequency converter will not be overheated if the brake resistor is overloaded.

The brake is protected against short-circuiting of the brake resistor, and the brake transistor is monitored to ensure that short-circuiting of the transistor is detected. A relay/digital output can be used for protecting the brake resistor against overloading in connection with a fault in the frequency converter.

In addition, the brake makes it possible to read out the momentary power and the mean power for the latest 120 seconds. The brake can also monitor the power energizing and make sure it

does not exceed a limit selected in par. 2-12. In par. 2-13, select the function to carry out when the power transmitted to the brake resistor exceeds the limit set in par. 2-12.

**NB!**

Monitoring the brake power is not a safety function; a thermal switch is required for that purpose. The brake resistor circuit is not earth leakage protected.

*Over voltage control (OVC)* (exclusive brake resistor) can be selected as an alternative brake function in par. 2-17. This function is active for all units. The function ensures that a trip can be avoided if the DC link voltage increases. This is done by increasing the output frequency to limit the voltage from the DC link. It is a very useful function, e.g. if the ramp-down time is too short since tripping of the frequency converter is avoided. In this situation the ramp-down time is extended.

### 3.8.1. Mechanical Brakecontrol

For hoisting applications, it is necessary to be able to control an electro-magnetic brake. For controlling the brake, a relay output (relay1 or relay2) or a programmed digital output (terminal 27 or 29) is required. Normally, this output must be closed for as long as the frequency converter is unable to 'hold' the motor, e.g. because of too big load. In par. 5-40 (Array parameter), par. 5-30, or par. 5-31 (digital output 27 or 29), select *mechanical brake control* [32] for applications with an electro-magnetic brake.

When *mechanical brake control* [32] is selected, the mechanical brake relay stays closed during start until the output current is above the level selected in par. 2-20 *Release Brake Current*. During stop, the mechanical brake will close when the speed is below the level selected in par. 2-21 *Activate Brake Speed [RPM]*. If the frequency converter is brought into an alarm condition, i.e. over-voltage situation, the mechanical brake immediately cuts in. This is also the case during safe stop.

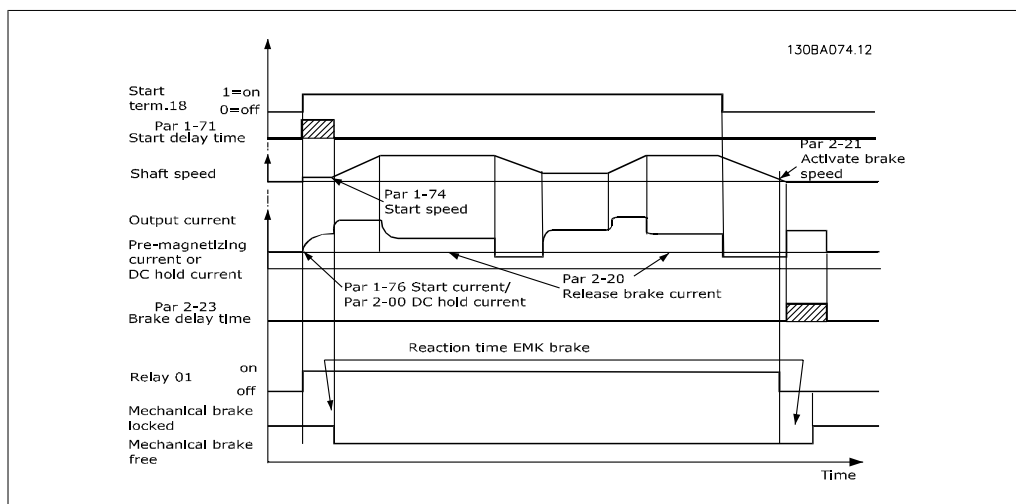

In hoisting/lowering applications, it must be possible to control an electro-mechanical brake.

### Step-by-step Description

- To control the mechanical brake any relay output or digital output (terminal 27 or 29) can be used. If necessary use a suitable contactor.
- Ensure that the output is switched off as long as the frequency converter is unable to drive the motor, for example due to the load being too heavy or due to the fact that the motor has not been mounted yet.
- Select *Mechanical brake control* [32] in par. 5-4\* (or in par. 5-3\*) before connecting the mechanical brake.
- The brake is released when the motor current exceeds the preset value in par. 2-20.
- The brake is engaged when the output frequency is less than the frequency set in par. 2-21 or 2-22 and only if the frequency converter carries out a stop command.



#### NB!

For vertical lifting or hoisting applications it is strongly recommended to ensure that the load can be stopped in case of an emergency or a malfunction of a single part such as a contactor, etc.

If the frequency converter is in alarm mode or in an over voltage situation, the mechanical brake cuts in.



#### NB!

For hoisting applications make sure that the torque limits in par. 4-16 and 4-17 are set lower than the current limit in par. 4-18. Also it is recommendable to set par. 14-25, *Trip Delay at Torque Limit* to "0", par. 14-26, *Trip Delay at Inverter Fault* to "0" and par. 14-10, *Mains Failure* to "[3], *Coasting*".

## 3.8.2. Hoist Mechanical Brake

The VLT Automation Drive FC 300 features a mechanical brake control specifically designed for hoisting applications. The hoist mechanical brake is activated by choice [6] in par. 1-72. The main difference compared to the regular mechanical brake control, where a relay function monitoring the output current is used, is that the hoist mechanical brake function has direct control over the brake relay. This means that instead of setting a current for release of the brake, the torque applied against the closed brake before release is defined. Because the torque is defined directly the setup is more straightforward for hoisting applications.

By using the Proportional Gain Boost (par. 2-28) a quicker control when releasing the brake can be obtained. The hoist mechanical brake strategy is based on a 3-step sequence, where motor control and brake release are synchronized in order to obtain the smoothest possible brake release.

### 3-step sequence

1. **Pre-magnetize the motor**  
In order to ensure that there is a hold on the motor and to verify that it is mounted correctly, the motor is first pre-magnetized.
2. **Apply torque against the closed brake**  
When the load is held by the mechanical brake, its size cannot be determined, only its direction. The moment the brake opens, the load must be taken over by the motor. To facilitate the takeover, a user defined torque, set in par. 2-26, is applied in hoisting direction. This will be used to initialize the speed controller that will finally take over the load. In order to reduce wear on the gearbox due to backlash, the torque is ramped up.
3. **Release brake**  
When the torque reaches the value set in par. 2-26 *Torque Ref*, the brake is released. The value set in par. 2-25 *Brake Release Time* determines the delay before the load is released. In order to react as quickly as possible on the load-step that follows upon brake release, the speed-PID control can be boosted by increasing the proportional gain.

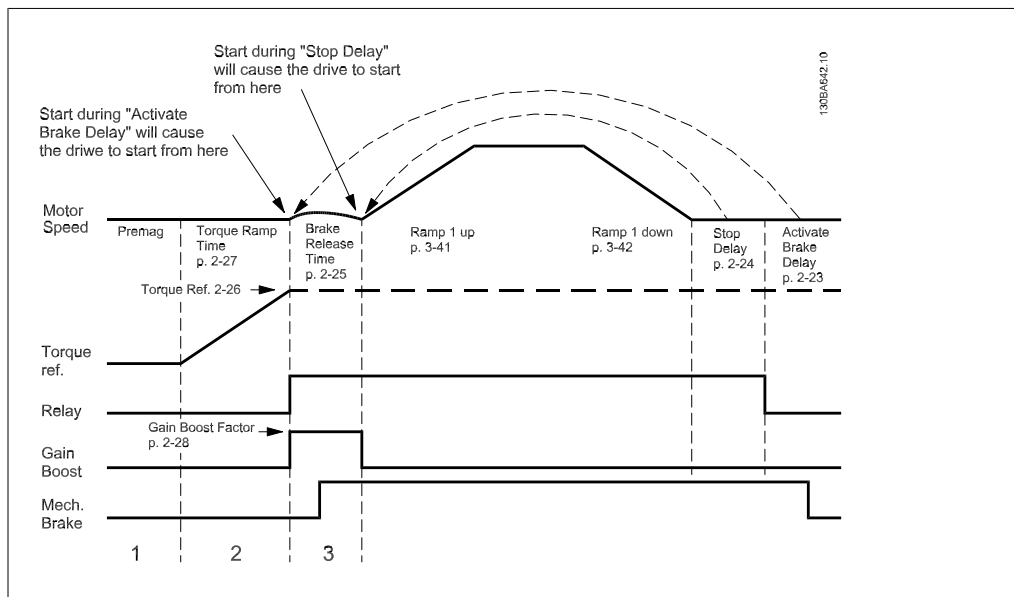

Illustration 3.4: Brake release sequence for hoist mechanical brake control

### 3.8.3. Cabling

EMC (twisted cables/shielding)

To reduce the electrical noise from the wires between the brake resistor and the frequency converter, the wires must be twisted.

For enhanced EMC performance a metal screen can be used.

### 3.9.1. Smart Logic Control

The Smart Logic Control (SLC) is essentially a sequence of user defined actions (see par. 13-52) executed by the SLC when the associated user defined *event* (see par. 13-51) is evaluated as TRUE by the SLC.

*Events* and *actions* are each numbered and are linked in pairs called states. This means that when *event [1]* is fulfilled (attains the value TRUE), *action [1]* is executed. After this, the conditions of *event [2]* will be evaluated and if evaluated TRUE, *action [2]* will be executed and so on. Events and actions are placed in array parameters.

Only one *event* will be evaluated at any time. If an *event* is evaluated as FALSE, nothing happens (in the SLC) during the present scan interval and no other *events* will be evaluated. This means that when the SLC starts, it evaluates *event [1]* (and only *event [1]*) each scan interval. Only when *event [1]* is evaluated TRUE, the SLC executes *action [1]* and starts evaluating *event [2]*.

It is possible to program from 0 to 20 *events* and *actions*. When the last *event / action* has been executed, the sequence starts over again from *event [1] / action [1]*. The illustration shows an example with three *events / actions*.



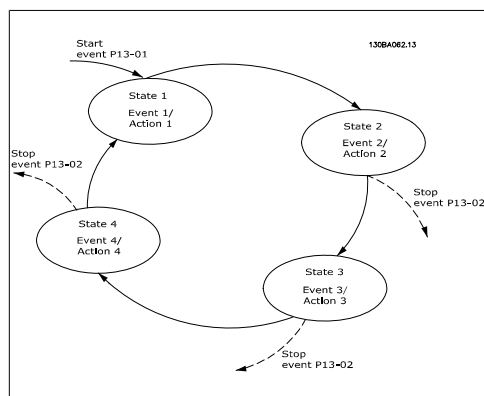

### Short Circuit (Motor Phase – Phase)

The frequency converter is protected against short circuits by means of current measurement in each of the three motor phases or in the DC link. A short circuit between two output phases will cause an overcurrent in the inverter. The inverter will be turned off individually when the short circuit current exceeds the permitted value (Alarm 16 Trip Lock).

To protect the drive against a short circuit at the load sharing and brake outputs please see the design guidelines.

### Switching on the Output

Switching on the output between the motor and the frequency converter is fully permitted. You cannot damage the frequency converter in any way by switching on the output. However, fault messages may appear.

### Motor-generated Overvoltage

The voltage in the intermediate circuit is increased when the motor acts as a generator. This occurs in following cases:

1. The load drives the motor (at constant output frequency from the frequency converter), ie. the load generates energy.
2. During deceleration ("ramp-down") if the moment of inertia is high, the friction is low and the ramp-down time is too short for the energy to be dissipated as a loss in the frequency converter, the motor and the installation.
3. In-correct slip compensation setting may cause higher DC link voltage.

The control unit may attempt to correct the ramp if possible (par. 2-17 *Over-voltage Control*).

The inverter turns off to protect the transistors and the intermediate circuit capacitors when a certain voltage level is reached.

See par. 2-10 and par. 2-17 to select the method used for controlling the intermediate circuit voltage level.

### Mains Drop-out

During a mains drop-out, the frequency converter keeps running until the intermediate circuit voltage drops below the minimum stop level, which is typically 15% below the frequency converter's lowest rated supply voltage.

The mains voltage before the drop-out and the motor load determines how long it takes for the inverter to coast.

### Static Overload in VVCplus mode

When the frequency converter is overloaded (the torque limit in par. 4-16/4-17 is reached), the controls reduces the output frequency to reduce the load.

If the overload is excessive, a current may occur that makes the frequency converter cut out after approx. 5-10 s.

Operation within the torque limit is limited in time (0-60 s) in par. 14-25.

### 3.10.1. Motor Thermal Protection

The motor temperature is calculated on the basis of motor current, output frequency, and time or thermistor. See par. 1-90 in the Programming Guide.

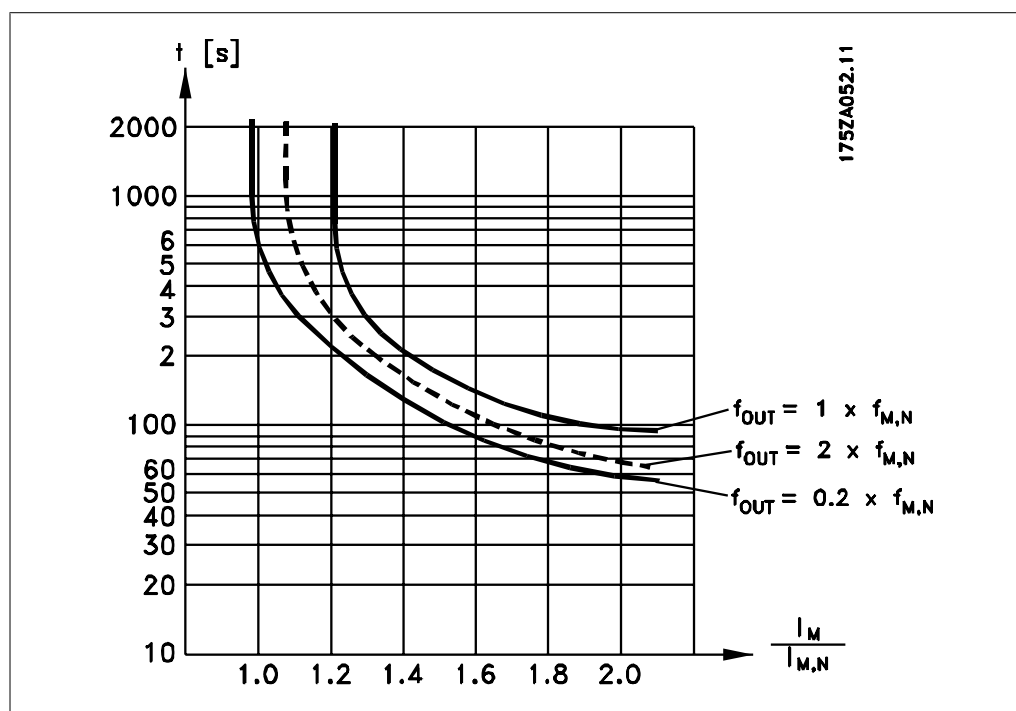

### 3.11.1. Safe Stop of FC 300

The FC 302, and also the FC301 in A1 enclosure, can perform the safety function *Safe Torque Off* (As defined by IEC 61800-5-2) or *Stop Category 0* (as defined in EN 60204-1).

FC 301 A1 enclosure: When Safe Stop is included in the drive, position 18 of Type Code must be either T or U. If position 18 is B or X, Safe Stop Terminal 37 is not included!

Example:

Type Code for FC 301 A1 with Safe Stop: FC-301PK75T4**Z20**H4TGXXXXXXXXA0BXCXXXXD0

It is designed and approved suitable for the requirements of Safety Category 3 in EN 954-1. This functionality is called Safe Stop. Prior to integration and use of Safe Stop in an installation, a thorough risk analysis on the installation must be carried out in order to determine whether the Safe Stop functionality and safety category are appropriate and sufficient.

#### Activation and Termination of Safe Stop

The Safe Stop function is activated by switching off the 24Vdvc supply to the Terminal 37. By default the Safe Stop functions is set to an Unintended Restart Prevention behaviour. This means, in order to terminate Safe Stop and resume normal operation, first the 24Vdc must be reapplied to Terminal 37. Subsequently, a reset signal must be given (via Bus, Digital I/O, or [Reset] key).

The Safe Stop function can be set to an Automatic Restart behaviour by setting the value of parameter 5-19 from default value [1] to value [3]. If a MCB112 Option is connected to the drive, then Automatic Restart Behaviour is set by values [7] and [8]. Automatic Restart means that Safe Stop is terminated, and normal operation is resumed, as soon as the 24Vdc are reapplied to Terminal 37, no Reset signal is required.

IMPORTANT! Automatic Restart Behaviour is only allowed in one of the two situations:

1. The Unintended Restart Prevention is implemented by other parts of the Safe Stop installation.
2. A presence in the dangerous zone can be physically excluded when Safe Stop is not activated. In particular, the following paragraphs of standards under the EU Machinery Directive must be observed: 5.2.1, 5.2.2, and 5.2.3. of EN954-1:1996 (or ISO 13849-1:2006), 4.11.3 and 4.11.4 of EN292-2 (ISO 12100-2:2003).



Prüf- und Zertifizierungsstelle im BG-PRÜFZERT		<b>BGIA</b> Berufsgenossenschaftliches Institut für Arbeitsschutz <small>Hauptverband der gewerblichen Berufsgenossenschaften</small>		130BA373.10
Translation <small>In any case, the German original shall prevail.</small>		<b>Type Test Certificate</b>		
Name and address of the holder of the certificate: <small>(customer)</small>		Danfoss Drives A/S, Ulnoes 1 DK-6300 Graasten, Danmark		05 06004 <small>No. of certificate</small>
Name and address of the manufacturer:		Danfoss Drives A/S, Ulnoes 1 DK-6300 Graasten, Danmark		
Ref. of customer:	Ref. of Test and Certification Body: <small>Apf/Koh VE-Nr. 2003 23220</small>	Date of issue: 13.04.2005		
Product designation:	Frequency converter with integrated safety functions			
Type:	VLT® Automation Drive FC 302			
Intended purpose:	Implementation of safety function „Safe Stop“			
Testing based on:	EN 954-1, 1997-03, DKE AK 226.03, 1998-06, EN ISO 13849-2; 2003-12, EN 61800-3, 2001-02, EN 61800-5-1, 2003-09,			
Test certificate:	No.: 2003 23220 from 13.04.2005			
Remarks:	The presented types of the frequency converter FC 302 meet the requirements laid down in the test bases. With correct wiring a category 3 according to DIN EN 954-1 is reached for the safety function.			
The type tested complies with the provisions laid down in the directive 98/37/EC (Machinery).				
Further conditions are laid down in the Rules of Procedure for Testing and Certification of April 2004.				
Head of certification body  <small>(Prof. Dr. rer. nat. Diether Reinert)</small>		Certification officer  <small>(Dipl.-Ing. R. Apfeld)</small>		
FZB10E 01.05		Postal address: 53754 Senkt Augustin	Office: Ake Heerstraße 111 53757 Senkt Augustin	Phone: 0 22 41/2 31-02 Fax: 0 22 41/2 31-22 34

### 3.11.2. Safe Stop Installation (FC 302 and FC 301 - A1 enclosure only)

To carry out an installation of a Category 0 Stop (EN60204) in conformance with Safety Category 3 (EN954-1), follow these instructions:

1. The bridge (jumper) between Terminal 37 and 24 V DC must be removed. Cutting or breaking the jumper is not sufficient. Remove it entirely to avoid short-circuiting. See jumper on illustration.
2. Connect terminal 37 to 24 V DC by a short-circuit protected cable. The 24 V DC voltage supply must be interruptible by an EN954-1 Category 3 circuit interrupt device. If the interrupt device and the frequency converter are placed in the same installation panel, you can use a regular cable instead of a protected one.
3. Unless the FC302 itself has protection class IP54 and higher, it must be placed in an IP 54 enclosure. Consequently, FC301 A1 must always be placed in an IP 54 enclosure.

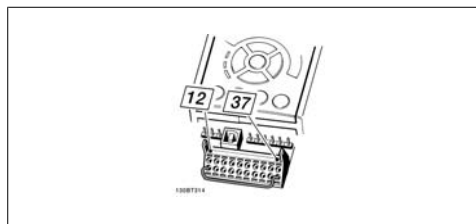

Illustration 3.5: Bridge jumper between terminal 37 and 24 VDC

The illustration below shows a Stopping Category 0 (EN 60204-1) with safety Category 3 (EN 954-1). The circuit interrupt is caused by an opening door contact. The illustration also shows how to connect a non-safety related hardware coast.

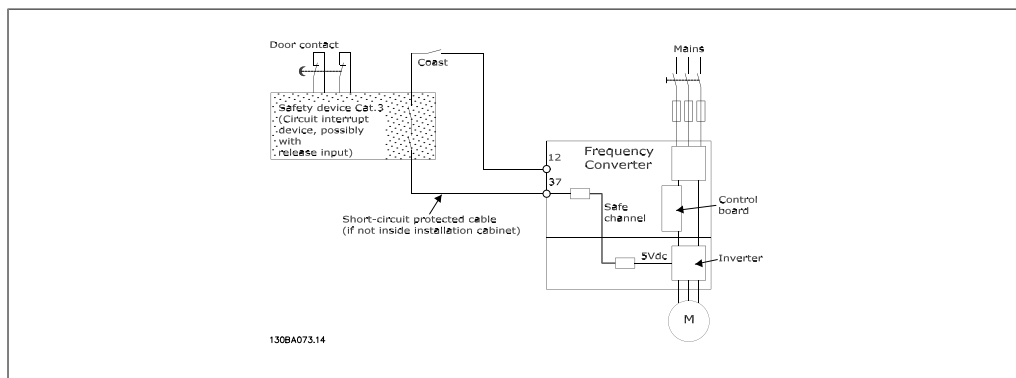

Illustration 3.6: Illustration of the essential aspects of an installation to achieve a Stopping Category 0 (EN 60204-1) with safety Category 3 (EN 954-1).

### 3.11.3. Installation for Safe Stop in combination with MCB112

If the Ex-certified thermistor module MCB112, which uses Terminal 37 as its safety-related switch-off channel, is connected, then the output X44/11 of MCB112 must be AND-ed with the safety-related sensor (such as emergency stop button, safety-guard switch, etc.) that activates Safe Stop. The AND logic itself must conform to EN 954-1, Safety Category 3. The connection from the output of the safe AND logic to Safe Stop terminal 37 must be short-circuit protected. See figure below:

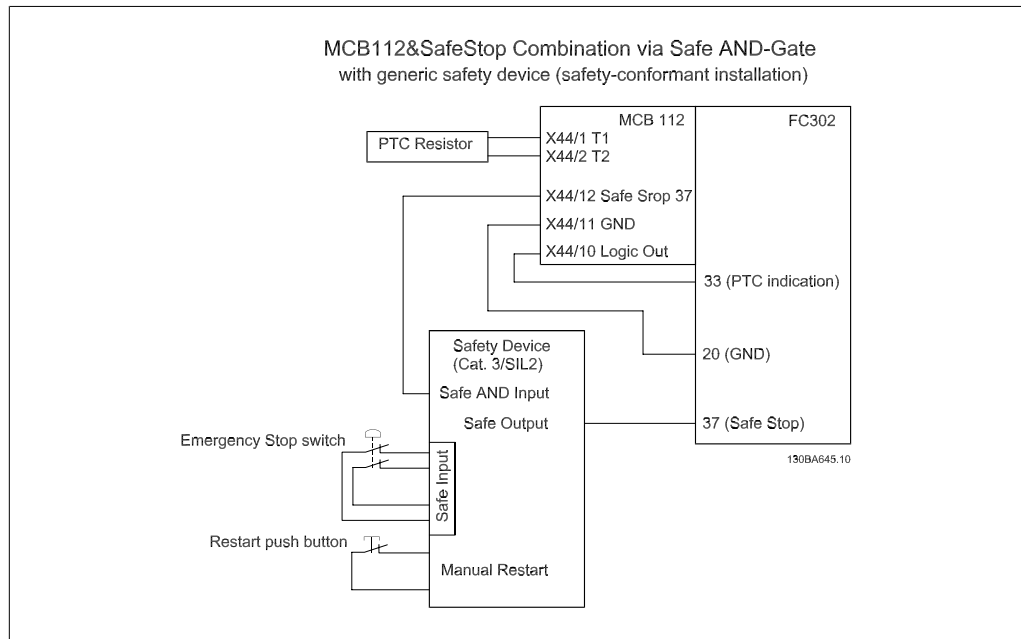

Illustration 3.7: Illustration of the essential aspects for installing a combination of a Safe Stop application and a MCB112 application. The diagram shows a Restart input for the external Safety Device. This means that in this installation parameter 5-19 might be set to value [7] or [8].

**Parameter settings for Safe Stop in combination with MCB112**

If MCB112 is connected, then additional settings are possible for parameter 5-19: [1] (default) and [3] are still available, but should not be set. They must be set if only Safe Stop is used. If [1] or [3] are chosen and MCB112 is triggered, then the FC300 will react with an alarm "Dangerous Failure [A72]" and stop the drive safely, without Automatic Restart. [4] and [5] are available then, but should not be used. They must be used if only MCB112 is connected, and no other safety-related sensor. If [4] or [5] are chosen and Safe Stop is activated, then the FC300 will react with an alarm "Dangerous Failure [A72]" and stop the drive safely, without Automatic Restart. Choices [6], [7], [8] or [9] must be used for combination of Safe Stop and MCB112. **IMPORTANT!** Choices [7] or [8] set Safe Stop to Automatic Restart.

This is only allowed in one of the two following situations:

1. The Unintended Restart Prevention is implemented by other parts of the Safe Stop installation.
2. A presence in the dangerous zone can be physically excluded when Safe Stop is not activated. In particular, the following paragraphs of standards under the EU Machinery Directive must be observed: 5.2.1, 5.2.2, and 5.2.3. of EN954-1:1996 (or ISO 13849-1:2006), 4.11.3 and 4.11.4 of EN292-2 (ISO 12100-2:2003).

**3.11.4. Safe Stop Commissioning Test**

After installation and before first operation, perform a commissioning test of an installation or application making use of FC 300 Safe Stop.

Moreover, perform the test after each modification of the installation or application, which the FC 300 Safe Stop is part of.

**NB!**  
A passed commissioning test is mandatory for fulfilment of Safety Category 3 by such an installation or application.

**The commissioning test (select one of cases 1 or 2 as applicable):**

**Case 1: restart prevention for Safe Stop is required (i.e. Safe Stop only where parameter 5-19 is set to default value [1], or combined Safe Stop and MCB112 where parameter 5-19 is set to [6] or [9]):**

1. Remove the 24 V DC voltage supply to terminal 37 by the interrupt device while the motor is driven by the FC 302 (i.e. mains supply is not interrupted). The test step is passed if the motor reacts with a coast and the mechanical brake (if connected) is activated, and if an LCP is mounted, the alarm "Safe Stop [A68]" is displayed.
2. Send Reset signal (via Bus, Digital I/O, or [Reset] key). The test step is passed if the motor remains in the Safe Stop state, and the mechanical brake (if connected) remains activated.
3. Reapply 24 V DC to terminal 37. The test step is passed if the motor remains in the coasted state, and the mechanical brake (if connected) remains activated. Step 1.4: Send Reset signal (via Bus, Digital I/O, or [Reset] key). The test step is passed if the motor becomes operational again.

The commissioning test is passed if all four test steps 1.1, 1.2, 1.3 and 1.4 are passed.

**Case 2: Automatic Restart of Safe Stop is wanted and allowed (i.e. Safe Stop only where parameter 5-19 is set to [3], or combined Safe Stop and MCB112 where parameter 5-19 is set to [7] or [8]):**

1. Remove the 24 V DC voltage supply to terminal 37 by the interrupt device while the motor is driven by the FC 302 (i.e. mains supply is not interrupted). The test step is passed if the motor reacts with a coast and the mechanical brake (if connected) is activated, and if an LCP is mounted, the warning "Safe Stop [W68]" is displayed.
2. Send Reset signal (via Bus, Digital I/O, or [Reset] key). The test step is passed if the motor remains in the Safe Stop state, and the mechanical brake (if connected) remains activated.
3. Reapply 24 V DC to terminal 37.

The test step is passed if the motor becomes operational again. The commissioning test is passed if all three test steps 2.1, 2.2, and 2.3 are passed.

**NB!**

The Safe Stop function of FC 302 can be used for asynchronous and synchronous motors. It may happen that two faults occur in the frequency converter's power semiconductor. When using synchronous motors this may cause a residual rotation. The rotation can be calculated to  $\text{Angle} = 360 / (\text{Number of Poles})$ . The application using synchronous motors must take this into consideration and ensure that this is not a safety critical issue. This situation is not relevant for asynchronous motors.

**NB!**

In order to use the Safe Stop functionality in conformance with the requirements of EN-954-1 Category 3, a number of conditions must be fulfilled by the installation of Safe Stop. Please see section *Safe Stop Installation* for further information.

**NB!**

The frequency converter does not provide a safety-related protection against unintended or malicious voltage supply to terminal 37 and subsequent reset. Provide this protection via the interrupt device, at the application level, or organisational level. For more information - see section *Safe Stop Installation*.

# 4. FC 300 Selection

## 4.1. Electrical Data

4

<b>Mains Supply 3 x 200 - 240 VAC</b>										
FC 301/FC 302		PK25	PK37	PK55	PK75	P1K1	P1K5	P2K2	P3K0	P3K7
Typical Shaft Output [kW]		0.25	0.37	0.55	0.75	1.1	1.5	2.2	3	3.7
Enclosure IP 20/IP 21		A2	A2	A2	A2	A2	A2	A2	A3	A3
Enclosure IP 20 (FC 301 only)		A1	A1	A1	A1	A1	A1	-	-	-
Enclosure IP 55, 66		A5	A5	A5	A5	A5	A5	A5	A5	A5
<b>Output current</b>										
Continuous (3 x 200-240 V) [A]		1.8	2.4	3.5	4.6	6.6	7.5	10.6	12.5	16.7
Intermittent (3 x 200-240 V) [A]		2.9	3.8	5.6	7.4	10.6	12.0	17.0	20.0	26.7
Continuous KVA (208 V AC) [KVA]		0.65	0.86	1.26	1.66	2.38	2.70	3.82	4.50	6.00
Max. cable size (mains, motor, brake) [mm <sup>2</sup> (AWG <sup>2</sup> )]		0.2 - 4 (24 - 10)								
<b>Max. input current</b>										
Continuous (3 x 200-240 V) [A]		1.6	2.2	3.2	4.1	5.9	6.8	9.5	11.3	15.0
Intermittent (3 x 200-240 V) [A]		2.6	3.5	5.1	6.6	9.4	10.9	15.2	18.1	24.0
Max. pre-fuses <sup>1)</sup> [A]		10	10	10	10	20	20	20	32	32
<b>Environment</b>										
Estimated power loss at rated max. load [W] <sup>4)</sup>		21	29	42	54	63	82	116	155	185
<b>Weight, enclosure IP20 [kg]</b>										
A1 (IP20)		2.7	2.7	2.7	2.7	2.7	2.7	-	-	-
A5 (IP55, 66)		13.5	13.5	13.5	13.5	13.5	13.5	13.5	13.5	13.5
Efficiency <sup>4)</sup>		0.94	0.94	0.95	0.95	0.96	0.96	0.96	0.96	0.96
0.25 - 3.7 kW only available as 160% high overload.										

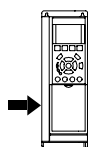

4

<b>Mains Supply 3 x 200- 240 VAC</b>									
FC 301/FC 302			P5K5		P7K5		P11K		
High/ Normal Load*			HO	NO	HO	NO	HO	NO	
	Typical Shaft Output [kW]		5.5	7.5	7.5	11	11	15	
	Enclosure IP21		B1		B1		B2		
	Enclosure IP55, 66		B1		B1		B2		
<b>Output current</b>									
	Continuous (3 x 200-240 V) [A]		24.2	30.8	30.8	46.2	46.2	59.4	
	Intermittent (60 sec overload) (3 x 200-240 V) [A]		38.7	33.9	49.3	50.8	73.9	65.3	
	Continuous KVA (208 V AC) [KVA]		8.7	11.1	11.1	16.6	16.6	21.4	
<b>Max. input current</b>									
	Continuous (3 x 200-240 V) [A]		22	28	28	42	42	54	
	Intermittent (60 sec overload) (3 x 200-240 V) [A]		35.2	30.8	44.8	46.2	67.2	59.4	
	Max. cable size [mm <sup>2</sup> (AWG)] <sup>2)</sup>		16 (6)		16 (6)		35 (2)		
	Max. pre-fuses [A] <sup>1)</sup>		63		63		80		
	Estimated power loss at rated max. load [W] <sup>4)</sup>		239	310	371	514	463	602	
	Weight, enclosure IP21, IP 55, 66 [kg]		23		23		27		
	Efficiency <sup>4)</sup>		0.964		0.959		0.964		
* High overload = 160% torque during 60 s, Normal overload = 110% torque during 60 s									

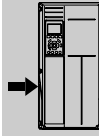

<b>Mains Supply 3 x 200- 240 VAC</b>											
FC 301/FC 302		P15K		P18K5		P22K		P30K		P37K	
High/ Normal Load*		HO	NO	HO	NO	HO	NO	HO	NO	HO	NO
	Typical Shaft Output [kW]	15	18.5	18.5	22	22	30	30	37	37	45
	Enclosure IP21	C1		C1		C1		C2		C2	
	Enclosure IP55, 66	C1		C1		C1		C2		C2	
<b>Output current</b>											
	Continuous (3 x 200-240 V) [A]	59.4	74.8	74.8	88	88	115	115	143	143	170
	Intermittent (60 sec overload) (3 x 200-240 V) [A]	89.1	82.3	112	96.8	132	127	173	157	215	187
	Continuous KVA (208 V AC) [KVA]	21.4	26.9	26.9	31.7	31.7	41.4	41.4	51.5	51.5	61.2
<b>Max. input current</b>											
	Continuous (3 x 200-240 V) [A]	54	68	68	80	80	104	104	130	130	154
	Intermittent (60 sec overload) (3 x 200-240 V) [A]	81	74.8	102	88	120	114	156	143	195	169
	Max. cable size [mm <sup>2</sup> (AWG)] <sup>2)</sup>	90 (3/0)		90 (3/0)		90 (3/0)		120 (4/0)		120 (4/0)	
	Max. pre-fuses [A] <sup>1)</sup>	125		125		160		200		250	
	Estimated power loss at rated max. load [W] <sup>4)</sup>	624	737	740	845	874	1140	1143	1353	1400	1636
	Weight, enclosure IP21, IP 55, 66 [kg]	45		45		45		65		65	
	Efficiency <sup>4)</sup>	0.964		0.965		0.965		0.966		0.966	

\* High overload = 160% torque during 60 s, Normal overload = 110% torque during 60 s

<b>Mains Supply 3 x 380 - 500 VAC (FC 302), 3 x 380 - 480 VAC (FC 301)</b>										
	PK 37	PK 55	PK7 5	P1K1	P1K5	P2K2	P3K0	P4K0	P5K5	P7K5
FC 301/FC 302 Typical Shaft Output [kW]	0.37	0.55	0.75	1.1	1.5	2.2	3	4	5.5	7.5
Enclosure IP20/IP21	A2	A2	A2	A2	A2	A2	A2	A2	A3	A3
Enclosure IP20 (FC 301 only)	A1	A1	A1	A1	A1					
Enclosure IP55, 66	A5	A5	A5	A5	A5	A5	A5	A5	A5	A5
<b>Output current</b>										
<b>High overload 160% for 1 minute</b>										
Shaft output [kW]	0.37	0.55	0.75	1.1	1.5	2.2	3	4	5.5	7.5
Continuous (3 x 380-440 V) [A]	1.3	1.8	2.4	3	4.1	5.6	7.2	10	13	16
Intermittent (3 x 380-440 V) [A]	2.1	2.9	3.8	4.8	6.6	9.0	11.5	16	20.8	25.6
Continuous (3 x 440-500 V) [A]	1.2	1.6	2.1	2.7	3.4	4.8	6.3	8.2	11	14.5
Intermittent (3 x 440-500 V) [A]	1.9	2.6	3.4	4.3	5.4	7.7	10.1	13.1	17.6	23.2
Continuous KVA (400 V AC) [KVA]	0.9	1.3	1.7	2.1	2.8	3.9	5.0	6.9	9.0	11.0
Continuous KVA (460 V AC) [KVA]	0.9	1.3	1.7	2.4	2.7	3.8	5.0	6.5	8.8	11.6
Max. cable size (mains, motor, brake) [AWG] <sup>2)</sup> [mm <sup>2</sup> ]				24 - 10 AWG 0.2 - 4 mm <sup>2</sup>				24 - 10 AWG 0.2 - 4 mm <sup>2</sup>		
<b>Max. input current</b>										
Continuous (3 x 380-440 V) [A]	1.2	1.6	2.2	2.7	3.7	5.0	6.5	9.0	11.7	14.4
Intermittent (3 x 380-440 V) [A]	1.9	2.6	3.5	4.3	5.9	8.0	10.4	14.4	18.7	23.0
Continuous (3 x 440-500 V) [A]	1.0	1.4	1.9	2.7	3.1	4.3	5.7	7.4	9.9	13.0
Intermittent (3 x 440-500 V) [A]	1.6	2.2	3.0	4.3	5.0	6.9	9.1	11.8	15.8	20.8
Max. pre-fuses <sup>1)</sup> [A]	10	10	10	10	10	20	20	20	32	32
<b>Environment</b>										
Estimated power loss at rated max. load [W] <sup>4)</sup>	35	42	46	58	62	88	116	124	187	255
Weight, enclosure IP20	4.7	4.7	4.8	4.8	4.9	4.9	4.9	4.9	6.6	6.6
Enclosure IP55, 66	13.5	13.5	13.5	13.5	13.5	13.5	13.5	13.5	14.2	14.2
Efficiency <sup>4)</sup>	0.93	0.95	0.96	0.96	0.97	0.97	0.97	0.97	0.97	0.97

0.37 - 7.5 kW only available as 160% high overload.

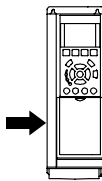
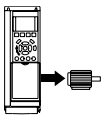

<b>Mains Supply 3 x 380 - 500 VAC (FC 302), 3 x 380 - 480 VAC (FC 301)</b>										
FC 301/FC 302	P11K		P15K		P18K		P22K			
High/ Normal Load*	HO	NO	HO	NO	HO	NO	HO	NO		
Typical Shaft output [kW]	11	15	15	18.5	18.5	22.0	22.0	30.0		
Enclosure IP21	B1		B1		B2		B2			
Enclosure IP55, 66	B1		B1		B2		B2			
<b>Output current</b>										
	Continuous (3 x 380-440 V) [A]	24	32	32	37.5	37.5	44	44	61	
	Intermittent (60 sec overload) (3 x 380-440 V) [A]	38.4	35.2	51.2	41.3	60	48.4	70.4	67.1	
	Continuous (3 x 440-500 V) [A]	21	27	27	34	34	40	40	52	
	Intermittent (60 sec overload) (3 x 440-500 V) [A]	33.6	29.7	43.2	37.4	54.4	44	64	57.2	
	Continuous KVA (400 V AC) [KVA]	16.6	22.2	22.2	26	26	30.5	30.5	42.3	
	Continuous KVA (460 V AC) [KVA]		21.5		27.1		31.9		41.4	
	<b>Max. input current</b>									
		Continuous (3 x 380-440 V) [A]	22	29	29	34	34	40	40	55
		Intermittent (60 sec overload) (3 x 380-440 V) [A]	35.2	31.9	46.4	37.4	54.4	44	64	60.5
		Continuous (3 x 440-500 V) [A]	19	25	25	31	31	36	36	47
Intermittent (60 sec overload) (3 x 440-500 V) [A]		30.4	27.5	40	34.1	49.6	39.6	57.6	51.7	
Max. cable size [mm <sup>2</sup> / AWG] <sup>2)</sup>		16/6		16/6		35/2		35/2		
Max. pre-fuses [A] <sub>1</sub>		63		63		63		80		
Estimated power loss at rated max. load [W] <sup>4)</sup>		291	392	379	465	444	525	547	739	
Weight, enclosure IP21, IP55, 66 [kg]	23		23		27		27			
Efficiency <sup>4)</sup>	0.977		0.978		0.979		0.978			
* High overload = 160% torque during 60 s, Normal overload = 110% torque during 60 s										

<b>Mains Supply 3 x 380 - 500 VAC (FC 302), 3 x 380 - 480 VAC (FC 301)</b>												
FC 301/FC 302		P30K		P37K		P45K		P55K		P75K		
High/ Normal Load*		HO	NO	HO	NO	HO	NO	HO	NO	HO	NO	
	Typical Shaft output [kW]	30	37	37	45	45	55	55	75	75	90	
	Enclosure IP21	C1		C1		C1		C2		C2		
	Enclosure IP55, 66	C1		C1		C1		C2		C2		
	<b>Output current</b>											
	Continuous (3 x 380-440 V) [A]	61	73	73	90	90	106	106	147	147	177	
	Intermittent (60 sec overload) (3 x 380-440 V) [A]	91.5	80.3	110	99	135	117	159	162	221	195	
	Continuous (3 x 440-500 V) [A]	52	65	65	80	80	105	105	130	130	160	
	Intermittent (60 sec overload) (3 x 440-500 V) [A]	78	71.5	97.5	88	120	116	158	143	195	176	
	Continuous KVA (400 V AC) [KVA]	42.3	50.6	50.6	62.4	62.4	73.4	73.4	102	102	123	
	Continuous KVA (460 V AC) [KVA]		51.8		63.7		83.7		104		128	
	<b>Max. input current</b>											
		Continuous (3 x 380-440 V) [A]	55	66	66	82	82	96	96	133	133	161
		Intermittent (60 sec overload) (3 x 380-440 V) [A]	82.5	72.6	99	90.2	123	106	144	146	200	177
		Continuous (3 x 440-500 V) [A]	47	59	59	73	73	95	95	118	118	145
Intermittent (60 sec overload) (3 x 440-500 V) [A]		70.5	64.9	88.5	80.3	110	105	143	130	177	160	
Max. cable size [mm <sup>2</sup> (AWG <sup>2</sup> )]		90 (3/0)		90 (3/0)		90 (3/0)		120 (4/0)		120 (4/0)		
Max. pre-fuses [A] <sup>1</sup>		100		125		160		250		250		
Estimated power loss at rated max. load [W] <sup>4)</sup>		570	698	697	843	891	1083	1022	1384	1232	1474	
Weight, enclosure IP21, IP 55, 66 [kg]		45		45		45		65		65		
Efficiency <sup>4)</sup>		0.983		0.983		0.982		0.983		0.985		
* High overload = 160% torque during 60 s, Normal overload = 110% torque during 60 s												

<b>Mains Supply 3 x 380 - 500 VAC</b>												
FC 302			P90K		P110		P132		P160		P200	
High/ Normal Load*	HO	NO	HO	NO	HO	NO	HO	NO	HO	NO	HO	NO
Typical Shaft output at 400 V [kW]	90	110	110	132	132	160	160	200	200	250	250	315
Typical Shaft output at 460 V [HP]	125	150	150	200	200	250	250	300	300	350	350	443
Typical Shaft output at 500 V [kW]	110	132	132	160	160	200	200	250	250	315	315	395
Enclosure IP21	D1	D1	D1	D1	D2	D2	D2	D2	D2	D2	D2	D2
Enclosure IP54	D1	D1	D1	D1	D2	D2	D2	D2	D2	D2	D2	D2
Enclosure IP00	D3	D3	D3	D3	D4	D4	D4	D4	D4	D4	D4	D4
<b>Output current</b>												
Continuous (at 400 V) [A]	177	212	212	260	260	315	315	395	395	480	480	600
Intermittent (60 sec overload) (at 400 V) [A]	266	233	318	286	390	347	473	435	593	528	593	728
Continuous (at 460/ 500 V) [A]	160	190	190	240	240	302	302	361	361	443	443	553
Intermittent (60 sec overload) (at 460/ 500 V) [A]	240	209	285	264	360	332	453	397	542	487	542	677
Continuous KVA (at 400 V) [KVA]	123	147	147	180	180	218	218	274	274	333	333	416
Continuous KVA (at 460 V) [KVA]	127	151	151	191	191	241	241	288	288	353	353	439
Continuous KVA (at 500 V) [KVA]	139	165	165	208	208	262	262	313	313	384	384	475
<b>Max. input current</b>												
Continuous (at 400 V) [A]	171	204	204	251	251	304	304	381	381	463	463	573
Continuous (at 460/ 500 V) [A]	154	183	183	231	231	291	291	348	348	427	427	527
Max. cable size [mm <sup>2</sup> (AWG <sup>2</sup> )]	150 (300 mcm)	2 x 70 (2 x 2/0)	2 x 70 (2 x 2/0)	2 x 70 (2 x 2/0)	2 x 70 (2 x 2/0)	2 x 185 (2 x 350 mcm)	2 x 185 (2 x 350 mcm)	2 x 185 (2 x 350 mcm)	2 x 185 (2 x 350 mcm)	2 x 185 (2 x 350 mcm)	2 x 185 (2 x 350 mcm)	2 x 185 (2 x 350 mcm)
Max. pre-fuses [A] <sup>1</sup>	300	350	350	400	400	400	400	500	500	500	500	600
Estimated power loss at rated max. load [W] <sup>4)</sup>	2641	3234	2995	3782	3425	4213	3910	5119	4625	5893	5893	7311
Weight, enclosure IP21, IP 54 [kg]	95.5	104	104	125	125	125	125	136	136	151	151	187
Weight, enclosure IP00 [kg]	81.9	91	91	112	112	112	112	123	123	138	138	171
Efficiency <sup>4)</sup>	0.971	0.973	0.973	0.974	0.974	0.974	0.974	0.976	0.976	0.977	0.977	0.977

\* High overload = 160% torque during 60 s, Normal overload = 110% torque during 60 s

<b>Mains Supply 3 x 380 - 500 VAC</b>									
FC 302	P250		P315		P355		P400		
High/ Normal Load*	HO	NO	HO	NO	HO	NO	HO	NO	
Typical Shaft output at 400 V [kW]	250	315	315	355	355	400	400	450	
Typical Shaft output at 460 V [HP]	350	450	450	500	500	600	550	600	
Typical Shaft output at 500 V [kW]	315	355	355	400	400	500	500	530	
Enclosure IP21	E1		E1		E1		E1		
Enclosure IP54	E1		E1		E1		E1		
Enclosure IP00	E2		E2		E2		E2		
<b>Output current</b>									
Continuous (at 400 V) [A]	480	600	600	658	658	745	695	800	
Intermittent (60 sec overload) (at 400 V) [A]	720	660	900	724	987	820	1043	880	
Continuous (at 460/ 500 V) [A]	443	540	540	590	590	678	678	730	
Intermittent (60 sec overload) (at 460/ 500 V) [A]	665	594	810	649	885	746	1017	803	
Continuous KVA (at 400 V) [KVA]	333	416	416	456	456	516	482	554	
Continuous KVA (at 460 V) [KVA]	353	430	430	470	470	540	540	582	
Continuous KVA (at 500 V) [KVA]	384	468	468	511	511	587	587	632	
<b>Max. input current</b>									
Continuous (at 400 V) [A]	472	590	590	647	647	733	684	787	
Continuous (at 460/ 500 V) [A]	436	531	531	580	580	667	667	718	
Max. cable size [mm <sup>2</sup> (AWG <sup>2</sup> )]	2 x 185 (2 x 350 mcm)		4x240 (4x500 mcm)		4x240 (4x500 mcm)		4x240 (4x500 mcm)		
Max. pre-fuses [A] <sub>1</sub>	700		900		900		900		
Estimated power loss at rated max. load [W] <sup>4)</sup>	6005	7630	6960	7701	7691	8879	7964	9428	
Weight, enclosure IP21, IP54 [kg]	263		270		272		313		
Weight, enclosure IP00 [kg]	221		234		236		277		
Efficiency <sup>4)</sup>	0.976		0.978		0.978		0.980		

\* High overload = 160% torque during 60 s, Normal overload = 110% torque during 60 s

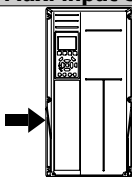
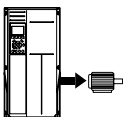

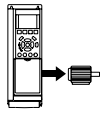
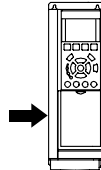
<b>Mains Supply 3 x 525 - 600 VAC (FC 302 only)</b>												
FC 302		PK75	P1K1	P1K5	P2K2	P3K0	P3K7	P4K0	P5K5	P7K5		
	Typical Shaft Output [kW]	0.75	1.1	1.5	2.2	3	3.7	4	5.5	7.5		
	<b>Output current</b>											
	Continuous (3 x 525-550 V) [A]	1.8	2.6	2.9	4.1	5.2	-	6.4	9.5	11.5		
	Intermittent (3 x 525-550 V) [A]	2.9	4.2	4.6	6.6	8.3	-	10.2	15.2	18.4		
	Continuous (3 x 525-600 V) [A]	1.7	2.4	2.7	3.9	4.9	-	6.1	9.0	11.0		
	Intermittent (3 x 525-600 V) [A]	2.7	3.8	4.3	6.2	7.8	-	9.8	14.4	17.6		
	Continuous kVA (525 V AC) [kVA]	1.7	2.5	2.8	3.9	5.0	-	6.1	9.0	11.0		
	Continuous kVA (575 V AC) [kVA]	1.7	2.4	2.7	3.9	4.9	-	6.1	9.0	11.0		
	Max. cable size (mains, motor, brake) [AWG] <sup>2)</sup> [mm <sup>2</sup> ]		24 - 10 AWG 0.2 - 4 mm <sup>2</sup>					-	24 - 10 AWG 0.2 - 4 mm <sup>2</sup>			
	<b>Max. input current</b>											
	Continuous (3 x 525-600 V) [A]	1.7	2.4	2.7	4.1	5.2	-	5.8	8.6	10.4		
	Intermittent (3 x 525-600 V) [A]	2.7	3.8	4.3	6.6	8.3	-	9.3	13.8	16.6		
	Max. pre-fuses <sup>1)</sup> [A]	10	10	10	20	20	-	20	32	32		
	<b>Environment</b>											
	Estimated power loss at rated max. load [W] <sup>4)</sup>	35	50	65	92	122	-	145	195	261		
	<b>Enclosure IP 20</b>											
	Weight, enclosure IP20 [kg]	6.5	6.5	6.5	6.5	6.5	-	6.5	6.6	6.6		
Efficiency <sup>4)</sup>	0.97	0.97	0.97	0.97	0.97	-	0.97	0.97	0.97			

4

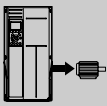
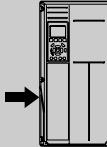
<b>Mains Supply 3 x 525- 690 VAC</b>												
FC 302			P37K		P45K		P55K		P75K		P90K	
High/ Normal Load*	HO	NO	HO	NO	HO	NO	HO	NO	HO	NO	HO	NO
Typical Shaft output at 690 V [kW]	37	45	45	55	55	75	75	90	90	90	110	
<b>Output current</b>												
	Continuous (at 690 V) [A]	46	54	54	73	73	86	86	108	108	131	
	Intermittent (60 sec overload) (at 690 V) [A]	74	59	86	80	117	95	129	119	162	144	
	Continuous KVA (at 690 V) [KVA]	55	65	65	87	87	103	103	129	129	157	
<b>Max. input current</b>												
	Continuous (at 690 V) [A]	50	58	58	77	77	87	87	109	109	128	
	Max. cable size [mm <sup>2</sup> (AWG)]	2x70 (2x2/0)										
Max. pre-fuses [A] <sup>1</sup>	80		90		125		150		175			
Estimated power loss at rated max. load [W] <sup>4)</sup>	1355	1458	1459	1717	1721	1913	1913	2262	2264	2662		
Weight, enclosure IP21, IP 54 [kg]												
Weight, enclosure IP00 [kg]												
Efficiency <sup>4)</sup>	0.98		0.98		0.98		0.98		0.98		0.98	

\* High overload = 160% torque during 60 s, Normal overload = 110% torque during 60 s



<b>Mains Supply 3 x 525- 690 VAC</b>										
FC 302	P110		P132		P160		P200			
High/ Normal Load*	HO	NO	HO	NO	HO	NO	HO	NO		
Typical Shaft output at 550 V [kW]	90	110	110	132	132	160	160	200		
Typical Shaft output at 575 V [HP]	125	150	150	200	200	250	250	300		
Typical Shaft output at 690 V [kW]	110	132	132	160	160	200	200	250		
<b>Output current</b>										
	Continuous (at 550 V) [A]	137	162	162	201	201	253	253	303	
	Intermittent (60 sec overload) (at 550 V) [A]	206	178	243	221	302	278	380	333	
	Continuous (at 575/ 690 V) [A]	131	155	155	192	192	242	242	290	
	Intermittent (60 sec overload) (at 575/ 690 V) [A]	197	171	233	211	288	266	363	319	
	Continuous KVA (at 550 V) [KVA]	131	154	154	191	191	241	241	289	
	Continuous KVA (at 575 V) [KVA]	130	154	154	191	191	241	241	289	
	Continuous KVA (at 690 V) [KVA]	157	185	185	229	229	289	289	347	
	<b>Max. input current</b>									
		Continuous (at 550 V ) [A]	130	158	158	198	198	245	245	299
		Continuous (at 575 V) [A]	124	151	151	189	189	234	234	286
Continuous (at 690 V) [A]		128	155	155	197	197	240	240	296	
Max. cable size [mm <sup>2</sup> (AWG)]	2 x 70 (2 x 2/0)	2 x 70 (2 x 2/0)	2 x 70 (2 x 2/0)	2 x 185 (2 x 350 mcm)	2 x 185 (2 x 350 mcm)	2 x 185 (2 x 350 mcm)	2 x 185 (2 x 350 mcm)	2 x 185 (2 x 350 mcm)		
Max. pre-fuses [A] <sub>1</sub>	225		250		350		400			
Estimated power loss at rated max. load [W] <sup>4)</sup>	2665	3114	2953	3612	3451	4293	4275	5156		
Weight, enclosure IP21, IP 54 [kg]	96		104		125		136			
Weight, enclosure IP00 [kg]	82		91		112		123			
Efficiency <sup>4)</sup>	0.976		0.978		0.978		0.979			

\* High overload = 160% torque during 60 s, Normal overload = 110% torque during 60 s

<b>Mains Supply 3 x 525- 690 VAC</b>		P250		P315		P355		
FC 302		HO	NO	HO	NO	HO	NO	
High/ Normal Load*								
	Typical Shaft output at 550 V [kW]	200	250	250	315	315	355	
	Typical Shaft output at 575 V [HP]	300	350	350	400	400	450	
	Typical Shaft output at 690 V [kW]	250	315	315	400	355	450	
<b>Output current</b>								
	Continuous (at 550 V) [A]	303	360	360	418	395	470	
	Intermittent (60 sec overload) (at 550 V) [A]	455	396	540	460	593	517	
	Continuous (at 575/ 690 V) [A]	290	344	344	400	380	450	
	Intermittent (60 sec overload) (at 575/ 690 V) [A]	435	378	516	440	570	495	
	Continuous KVA (at 550 V) [KVA]	289	343	343	398	376	448	
	Continuous KVA (at 575 V) [KVA]	289	343	343	398	378	448	
	Continuous KVA (at 690 V) [KVA]	347	411	411	478	454	538	
	<b>Max. input current</b>							
		Continuous (at 550 V) [A]	299	355	355	408	381	453
		Continuous (at 575 V) [A]	286	339	339	390	366	434
Continuous (at 690 V) [A]		296	352	352	400	366	434	
	Max. cable size [mm <sup>2</sup> (AWG)]	2 x 185 (2 x 350 mcm)		2 x 185 (2 x 350 mcm)		2 x 185 (2 x 350 mcm)		
	Max. pre-fuses [A] <sup>1</sup>	500		600		700		
	Estimated power loss at rated max. load [W] <sup>4)</sup>	4875	5821	5185	6149	5383	6449	
	Weight, enclosure IP21, IP 54 [kg]	151		165		263		
	Weight, enclosure IP00 [kg]	138		151		221		
	Efficiency <sup>4)</sup>	0.981		0.984		0.985		

\* High overload = 160% torque during 60 s, Normal overload = 110% torque during 60 s

4

<b>Mains Supply 3 x 525- 690 VAC</b>								
FC 302		P400		P500		P560		
High/ Normal Load*		HO	NO	HO	NO	HO	NO	
Typical Shaft output at 550 V [kW]		315	400	400	450	450	500	
Typical Shaft output at 575 V [HP]		400	500	500	600	600	650	
Typical Shaft output at 690 V [kW]		400	500	500	560	560	630	
<b>Output current</b>								
	Continuous (at 550 V) [A]	429	523	523	596	596	630	
	Intermittent (60 sec overload) (at 550 V) [A]	644	575	785	656	894	693	
	Continuous (at 575/ 690 V) [A]	410	500	500	570	570	630	
	Intermittent (60 sec overload) (at 575/ 690 V) [A]	615	550	750	627	855	693	
	Continuous KVA (at 550 V) [KVA]	409	498	498	568	568	600	
	Continuous KVA (at 575 V) [KVA]	408	498	498	568	568	627	
	Continuous KVA (at 690 V) [KVA]	490	598	598	681	681	753	
	<b>Max. input current</b>							
		Continuous (at 550 V ) [A]	413	504	504	574	574	607
		Continuous (at 575 V) [A]	395	482	482	549	549	607
Continuous (at 690 V) [A]		395	482	482	549	549	607	
Max. cable size [mm <sup>2</sup> (AWG)]		4x240 (4x500 mcm)		4x240 (4x500 mcm)		4x240 (4x500 mcm)		
Max. pre-fuses [A] <sup>1</sup>		700		900		900		
Estimated power loss at rated max. load [W] <sup>4)</sup>		5818	7249	7671	8727	8715	9673	
Weight, enclosure IP21, IP 54 [kg]		263		272		313		
Weight, enclosure IP00 [kg]		221		236		277		
Efficiency <sup>4)</sup>		0.985		0.985		0.984		

\* High overload = 160% torque during 60 s, Normal overload = 110% torque during 60 s

- 1) For type of fuse see section *Fuses*.
- 2) American Wire Gauge.
- 3) Measured using 5 m screened motor cables at rated load and rated frequency.
- 4) The typical power loss is at nominal load conditions and expected to be within +/-15% (tolerance relates to variety in voltage and cable conditions). Values are based on a typical motor efficiency (eff2/eff3 border line). Motors with lower efficiency will also add to the power loss in the frequency converter and opposite. If the switching frequency is increased compared to the default setting, the power losses may rise significantly.

LCP and typical control card power consumptions are included. Further options and customer load may add up to 30W to the losses. (Though typical only 4W extra for a fully loaded control card, or options for slot A or slot B, each). Although measurements are made with state of the art equipment, some measurement inaccuracy must be allowed for (+/-5%).

## 4.2. General Specifications

### Mains supply (L1, L2, L3):

Supply voltage	200-240 V $\pm$ 10%
Supply voltage	FC 301: 380-480 V / FC 302: 380-500 V $\pm$ 10%
Supply voltage	FC 302: 525-690 V $\pm$ 10%
Supply frequency	50/60 Hz
Max. imbalance temporary between mains phases	3.0 % of rated supply voltage
True Power Factor ( $\lambda$ )	$\geq$ 0.9 nominal at rated load
Displacement Power Factor ( $\cos \phi$ )	near unity ( $>$ 0.98)
Switching on input supply L1, L2, L3 (power-ups) $\leq$ 7.5 kW	maximum 2 times/min.
Switching on input supply L1, L2, L3 (power-ups) $\geq$ 11 kW	maximum 1 time/min.
Environment according to EN60664-1	overvoltage category III/pollution degree 2

*The unit is suitable for use on a circuit capable of delivering not more than 100.000 RMS symmetrical Amperes, 240/500/600/ 690 V maximum.*

### Motor output (U, V, W):

Output voltage	0 - 100% of supply voltage
Output frequency (0.25-75 kW)	FC 301: 0.2 - 1000 Hz / FC 302: 0 - 1000 Hz
Output frequency (90-560 kW)	0 - 800 Hz
Output frequency in Flux Mode (FC 302 only)	0 - 300 Hz
Switching on output	Unlimited
Ramp times	0.01 - 3600 sec.

### Torque characteristics:

Starting torque (Constant torque)	maximum 160% for 60 sec.*
Starting torque	maximum 180% up to 0.5 sec.*
Overload torque (Constant torque)	maximum 160% for 60 sec.*
Starting torque (Variable torque)	maximum 110% for 60 sec.*
Overload torque (Variable torque)	maximum 110% for 60 sec.

*\*Percentage relates to the nominal torque.*

### Cable lengths and cross sections:

Max. motor cable length, screened	FC 301: 50 m / FC 301 (A1-encl.): 25 m/ FC 302: 150 m
Max. motor cable length, unscreened	FC 301: 75 m / FC 301 (A1-encl.): 50 m/ FC 302: 300 m
Max. cross section to motor, mains, load sharing and brake, (0.25 kW - 7.5 kW)	4 mm <sup>2</sup> / 10 AWG
Max. cross section to motor, mains, load sharing and brake, (11-15 kW)	16 mm <sup>2</sup> / 6 AWG
Max. cross section to motor, mains, load sharing and brake, (18.5-22 kW)	35 mm <sup>2</sup> / 2 AWG
Maximum cross section to control terminals, flexible/ rigid wire without cable end sleeves	1.5 mm <sup>2</sup> /16 AWG
Maximum cross section to control terminals, flexible wire with cable end sleeves	1 mm <sup>2</sup> /18 AWG
Maximum cross section to control terminals, flexible wire with cable end sleeves with collar	0.5 mm <sup>2</sup> /20 AWG
Minimum cross section to control terminals	0.25 mm <sup>2</sup> / 24 AWG

### Protection and Features:

- Electronic thermal motor protection against overload.
- Temperature monitoring of the heatsink ensures that the frequency converter trips if the temperature reaches a predefined level. An overload temperature cannot be reset until the temperature of the heatsink is below the values stated in the tables on the following

pages (Guideline - these temperatures may vary for different power sizes, enclosures etc.).

- The frequency converter is protected against short-circuits on motor terminals U, V, W.
- If a mains phase is missing, the frequency converter trips or issues a warning (depending on the load).
- Monitoring of the intermediate circuit voltage ensures that the frequency converter trips if the intermediate circuit voltage is too low or too high.
- The frequency converter constantly checks for critical levels of internal temperature, load current, high voltage on the intermediate circuit and low motor speeds. As a response to a critical level, the frequency converter can adjust the switching frequency and/ or change the switching pattern in order to ensure the performance of the drive.

#### Digital inputs:

Programmable digital inputs	FC 301: 4 (5) / FC 302: 4 (6)
Terminal number	18, 19, 27 <sup>1)</sup> , 29 <sup>4)</sup> , 32, 33,
Logic	PNP or NPN
Voltage level	0 - 24 V DC
Voltage level, logic '0' PNP	< 5 V DC
Voltage level, logic '1' PNP	> 10 V DC
Voltage level, logic '0' NPN <sup>2)</sup>	> 19 V DC
Voltage level, logic '1' NPN <sup>2)</sup>	< 14 V DC
Maximum voltage on input	28 V DC
Pulse frequency range	0 - 110 kHz
(Duty cycle) Min. pulse width	4.5 ms
Input resistance, R <sub>i</sub>	approx. 4 kΩ

#### Safe stop Terminal 37<sup>3)</sup> (Terminal 37 is fixed PNP logic):

Voltage level	0 - 24 V DC
Voltage level, logic '0' PNP	< 4 V DC
Voltage level, logic '1' PNP	> 20 V DC
Nominal input current at 24 V	50 mA rms
Nominal input current at 20 V	60 mA rms
Input capacitance	400 nF

All digital inputs are galvanically isolated from the supply voltage (PELV) and other high-voltage terminals.

1) Terminals 27 and 29 can also be programmed as output.

2) Except safe stop input Terminal 37.

3) Terminal 37 is only available in FC 302 and FC 301 A1 with Safe Stop. It can only be used as safe stop input. Terminal 37 is suitable for category 3 installations according to EN 954-1 (safe stop according to category 0 EN 60204-1) as required by the EU Machinery Directive 98/37/EC. Terminal 37 and the Safe Stop function are designed in conformance with EN 60204-1, EN 50178, EN 61800-2, EN 61800-3, and EN 954-1. For correct and safe use of the Safe Stop function follow the related information and instructions in the Design Guide.

4) FC 302 only.

#### Analog inputs:

Number of analog inputs	2
Terminal number	53, 54
Modes	Voltage or current
Mode select	Switch S201 and switch S202
Voltage mode	Switch S201/switch S202 = OFF (U)
Voltage level	FC 301: 0 to + 10/ FC 302: -10 to +10 V (scaleable)
Input resistance, R <sub>i</sub>	approx. 10 kΩ
Max. voltage	± 20 V

Current mode	Switch S201/switch S202 = ON (I)
Current level	0/4 to 20 mA (scaleable)
Input resistance, $R_i$	approx. 200 $\Omega$
Max. current	30 mA
Resolution for analog inputs	10 bit (+ sign)
Accuracy of analog inputs	Max. error 0.5% of full scale
Bandwidth	FC 301: 20 Hz/ FC 302: 100 Hz

*The analog inputs are galvanically isolated from the supply voltage (PELV) and other high-voltage terminals.*

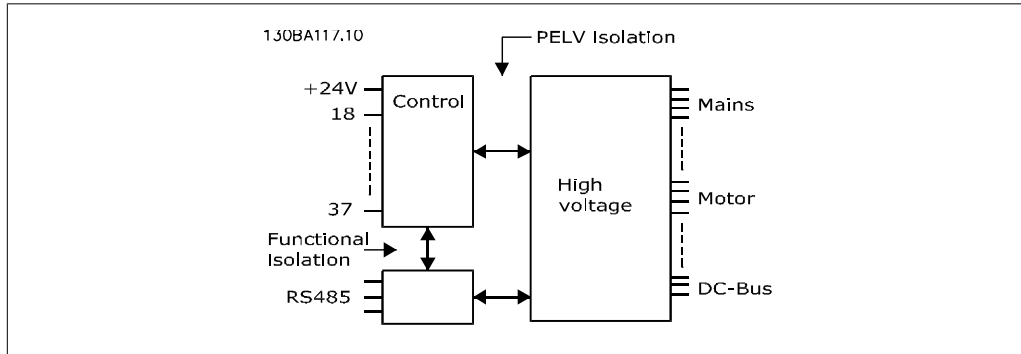

**Pulse/encoder inputs:**

Programmable pulse/encoder inputs	2/1
Terminal number pulse/encoder	29 <sup>1)</sup> , 33 <sup>2)</sup> / 32 <sup>3)</sup> , 33 <sup>3)</sup>
Max. frequency at terminal 29, 32, 33	110 kHz (Push-pull driven)
Max. frequency at terminal 29, 32, 33	5 kHz (open collector)
Min. frequency at terminal 29, 32, 33	4 Hz
Voltage level	see section on Digital input
Maximum voltage on input	28 V DC
Input resistance, $R_i$	approx. 4 k $\Omega$
Pulse input accuracy (0.1 - 1 kHz)	Max. error: 0.1% of full scale
Encoder input accuracy (1 - 110 kHz)	Max. error: 0.05 % of full scale

*The pulse and encoder inputs (terminals 29, 32, 33) are galvanically isolated from the supply voltage (PELV) and other high-voltage terminals.*

- 1) FC 302 only
- 2) Pulse inputs are 29 and 33
- 3) Encoder inputs: 32 = A, and 33 = B

**Analog output:**

Number of programmable analog outputs	1
Terminal number	42
Current range at analog output	0/4 - 20 mA
Max. load GND - analog output	500 $\Omega$
Accuracy on analog output	Max. error: 0.5 % of full scale
Resolution on analog output	12 bit

*The analogue output is galvanically isolated from the supply voltage (PELV) and other high-voltage terminals.*

**Control card, RS 485 serial communication:**

Terminal number	68 (P,TX+, RX+), 69 (N,TX-, RX-)
Terminal number 61	Common for terminals 68 and 69

*The RS 485 serial communication circuit is functionally separated from other central circuits and galvanically isolated from the supply voltage (PELV).*

## Digital output:

Programmable digital/pulse outputs	2
Terminal number	27, 29 <sup>1)</sup>
Voltage level at digital/frequency output	0 - 24 V
Max. output current (sink or source)	40 mA
Max. load at frequency output	1 k $\Omega$
Max. capacitive load at frequency output	10 nF
Minimum output frequency at frequency output	0 Hz
Maximum output frequency at frequency output	32 kHz
Accuracy of frequency output	Max. error: 0.1 % of full scale
Resolution of frequency outputs	12 bit

*1) Terminal 27 and 29 can also be programmed as input.*

*The digital output is galvanically isolated from the supply voltage (PELV) and other high-voltage terminals.*

## Control card, 24 V DC output:

Terminal number	12, 13
Output voltage	24 V +1, -3 V
Max. load	FC 301: 130 mA/ FC 302: 200 mA

*The 24 V DC supply is galvanically isolated from the supply voltage (PELV), but has the same potential as the analog and digital inputs and outputs.*

## Relay outputs:

Programmable relay outputs	FC 301 $\leq$ 7.5 kW: 1 / FC 302 all kW: 2
Relay 01 Terminal number	1-3 (break), 1-2 (make)
Max. terminal load (AC-1) <sup>1)</sup> on 1-3 (NC), 1-2 (NO) (Resistive load)	240 V AC, 2 A
Max. terminal load (AC-15) <sup>1)</sup> (Inductive load @ cos $\phi$ 0.4)	240 V AC, 0.2 A
Max. terminal load (DC-1) <sup>1)</sup> on 1-2 (NO), 1-3 (NC) (Resistive load)	60 V DC, 1A
Max. terminal load (DC-13) <sup>1)</sup> (Inductive load)	24 V DC, 0.1A
Relay 02 (FC 302 only) Terminal number	4-6 (break), 4-5 (make)
Max. terminal load (AC-1) <sup>1)</sup> on 4-5 (NO) (Resistive load)	400 V AC, 2 A
Max. terminal load (AC-15) <sup>1)</sup> on 4-5 (NO) (Inductive load @ cos $\phi$ 0.4)	240 V AC, 0.2 A
Max. terminal load (DC-1) <sup>1)</sup> on 4-5 (NO) (Resistive load)	80 V DC, 2 A
Max. terminal load (DC-13) <sup>1)</sup> on 4-5 (NO) (Inductive load)	24 V DC, 0.1A
Max. terminal load (AC-1) <sup>1)</sup> on 4-6 (NC) (Resistive load)	240 V AC, 2 A
Max. terminal load (AC-15) <sup>1)</sup> on 4-6 (NC) (Inductive load @ cos $\phi$ 0.4)	240 V AC, 0.2A
Max. terminal load (DC-1) <sup>1)</sup> on 4-6 (NC) (Resistive load)	50 V DC, 2 A
Max. terminal load (DC-13) <sup>1)</sup> on 4-6 (NC) (Inductive load)	24 V DC, 0.1 A
Min. terminal load on 1-3 (NC), 1-2 (NO), 4-6 (NC), 4-5 (NO)	24 V DC 10 mA, 24 V AC 20 mA
Environment according to EN 60664-1	overvoltage category III/pollution degree 2

*1) IEC 60947 part 4 and 5*

*The relay contacts are galvanically isolated from the rest of the circuit by reinforced isolation (PELV).*

## Control card, 10 V DC output:

Terminal number	50
Output voltage	10.5 V $\pm$ 0.5 V
Max. load	15 mA

*The 10 V DC supply is galvanically isolated from the supply voltage (PELV) and other high-voltage terminals.*



## Control characteristics:

Resolution of output frequency at 0 - 1000 Hz	+/- 0.003 Hz
Repeat accuracy of <i>Precise start/stop</i> (terminals 18, 19)	≤± 0.1 msec
System response time (terminals 18, 19, 27, 29, 32, 33)	≤ 2 ms
Speed control range (open loop)	1:100 of synchronous speed
Speed control range (closed loop)	1:1000 of synchronous speed
Speed accuracy (open loop)	30 - 4000 rpm: error ±8 rpm
Speed accuracy (closed loop), depending on resolution of feedback device	0 - 6000 rpm: error ±0.15 rpm

*All control characteristics are based on a 4-pole asynchronous motor*

## Control card performance:

Scan interval	FC 301: 5 ms / FC 302: 1 ms
---------------	-----------------------------

## Surroundings:

Enclosure ≤ 7.5 kW	IP 20, IP 55
Enclosure ≥ 11 kW	IP 21, IP 55
Enclosure kit available ≤ 7.5 kW	IP21/TYPE 1/IP 4X top
Vibration test	1.0 g RMS
Max. relative humidity	5% - 95%(IEC 60 721-3-3; Class 3K3 (non-condensing) during operation)
Aggressive environment (IEC 721-3-3), uncoated	class 3C2
Aggressive environment (IEC 721-3-3), coated	class 3C3
Test method according to IEC 60068-2-43 H2S (10 days)	
Ambient temperature	Max. 50 °C (24-hour average maximum 45 °C)

*Derating for high ambient temperature, see section on special conditions*

Minimum ambient temperature during full-scale operation	0 °C
Minimum ambient temperature at reduced performance	- 10 °C
Temperature during storage/transport	-25 - +65/70 °C
Maximum altitude above sea level	1000 m

*Derating for high altitude, see section on special conditions*

EMC standards, Emission	EN 61800-3, EN 61000-6-3/4, EN 55011 EN 61800-3, EN 61000-6-1/2, EN 61000-4-2, EN 61000-4-3, EN 61000-4-4, EN 61000-4-5, EN
EMC standards, Immunity	61000-4-6

*See section on special conditions*

## Control card, USB serial communication:

USB standard	1.1 (Full speed)
USB plug	USB type B "device" plug

*Connection to PC is carried out via a standard host/device USB cable.*

*The USB connection is galvanically isolated from the supply voltage (PELV) and other high-voltage terminals.*

*The USB ground connection is not galvanically isolated from protection earth. Use only an isolated laptop as PC connection to the USB connector on the frequency converter.*

### 4.3.1. Efficiency

#### Efficiency of FC 300 Series ( $\eta_{VLT}$ )

The load on the frequency converter has little effect on its efficiency. In general, the efficiency is the same at the rated motor frequency  $f_{M,N}$ , even if the motor supplies 100% of the rated shaft torque or only 75%, i.e. in case of part loads.

This also means that the efficiency of the frequency converter does not change even if other U/f characteristics are chosen.

However, the U/f characteristics influence the efficiency of the motor.

The efficiency declines a little when the switching frequency is set to a value of above 5 kHz. The efficiency will also be slightly reduced if the mains voltage is 500 V, or if the motor cable is longer than 30 m.

#### Efficiency of the motor ( $\eta_{\text{MOTOR}}$ )

The efficiency of a motor connected to the frequency converter depends on magnetising level. In general, the efficiency is just as good as with mains operation. The efficiency of the motor depends on the type of motor.

In the range of 75-100% of the rated torque, the efficiency of the motor is practically constant, both when it is controlled by the frequency converter and when it runs directly on mains.

In small motors, the influence from the U/f characteristic on efficiency is marginal. However, in motors from 11 kW and up, the advantages are significant.

In general, the switching frequency does not affect the efficiency of small motors. Motors from 11 kW and up have their efficiency improved (1-2%). This is because the sine shape of the motor current is almost perfect at high switching frequency.

#### Efficiency of the system ( $\eta_{\text{SYSTEM}}$ )

To calculate the system efficiency, the efficiency of FC 300 Series ( $\eta_{\text{VLT}}$ ) is multiplied by the efficiency of the motor ( $\eta_{\text{MOTOR}}$ ):

$$\eta_{\text{SYSTEM}} = \eta_{\text{VLT}} \times \eta_{\text{MOTOR}}$$

### 4.4.1. Acoustic Noise

**The acoustic noise from the frequency converter comes from three sources:**

1. DC intermediate circuit coils.
2. Integral fan.
3. RFI filter choke.

The typical values measured at a distance of 1 m from the unit:

FC 301/ FC 302	
PK25-P7K5: @ 400 V	IP20/IP21/NEMA TYPE 1
PK25-P7K5	IP55/NEMA TYPE 12
Reduced fan speed	51 dB(A)
Full fan speed	60 dB(A)

**When a transistor in the inverter bridge switches, the voltage across the motor increases by a du/dt ratio depending on:**

- the motor cable (type, cross-section, length screened or unscreened)
- inductance

The natural induction causes an overshoot  $U_{\text{PEAK}}$  in the motor voltage before it stabilises itself at a level depending on the voltage in the intermediate circuit. The rise time and the peak voltage  $U_{\text{PEAK}}$  affect the service life of the motor. If the peak voltage is too high, especially motors without phase coil insulation are affected. If the motor cable is short (a few metres), the rise time and peak voltage are lower.

If the motor cable is long (100 m), the rise time and peak voltage are higher.

In motors without phase insulation paper or other insulation reinforcement suitable for operation with voltage supply (such as a frequency converter), fit a du/dt filter or a sine-wave filter on the output of the frequency converter.

### 4.6.1. du/dt conditions

Peak voltage on the motor terminals is caused by the switching of the IGBTs. FC300 complies with the demands of IEC 60034-25 regarding motors designed to be controlled by frequency converters. FC 300 also complies with IEC 60034-17 regarding Norm motors controlled by frequency converters

Measured values from lab tests:

Cable length	FC 300 1.5 kW, 400 V		FC 300 4.0 kW, 400 V		FC 300 7.5 kW, 400 V	
	$U_{peak}[V]$	$du/dt$ V/ $\mu$ s	$U_{peak}[V]$	$du/dt$ V/ $\mu$ s	$U_{peak}[V]$	$du/dt$ V/ $\mu$ s
5	690	1329	890	4156	739	8035
50	985	985	180	2564	1040	4548
150 <sup>1)</sup>	1045	947	1190	1770	1030	2828

1) FC 302 only

## 4.7. Special Conditions

### 4.7.1. Purpose of derating

Derating must be taken into account when using the frequency converter at low air pressure (heights), at low speeds, with long motor cables, cables with a large cross section or at high ambient temperature. The required action is described in this section.

### 4.7.2. Derating for Ambient Temperature

The average temperature ( $T_{AMB,AVG}$ ) measured over 24 hours must be at least 5 °C lower than the maximum allowed ambient temperature ( $T_{AMB,MAX}$ ).

If the frequency converter is operated at high ambient temperatures, the continuous output current should be decreased.

The derating depends on the switching pattern, which can be set to 60 PWM or SFAVM in par. 14-00.

#### A enclosures

##### 60 PWM - Pulse Width Modulation

4

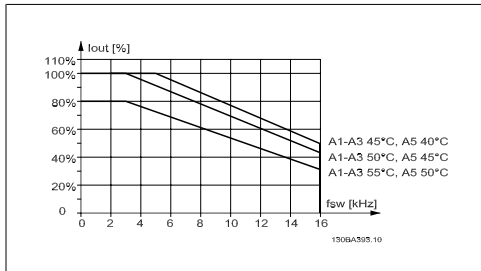

Illustration 4.1: Derating of  $I_{out}$  for different  $T_{AMB, MAX}$  for enclosure A, using 60 PWM

**SFAVM - Stator Frequency Asynchron Vector Modulation**

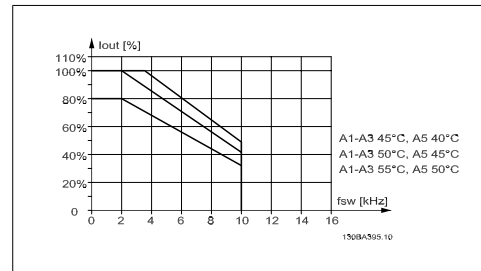

Illustration 4.2: Derating of  $I_{out}$  for different  $T_{AMB, MAX}$  for enclosure A, using SFAVM

When using only 10 m motor cable or less in frame size A, less derating is necessary. This is due to the fact that the length of the motor cable has a relatively high impact on the recommended derating.

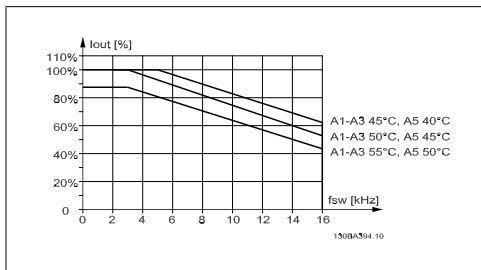

Illustration 4.3: Derating of  $I_{out}$  for different  $T_{AMB, MAX}$  for enclosure A, using 60 PWM and maximum 10 m motor cable

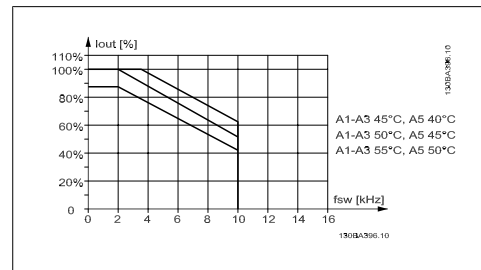

Illustration 4.4: Derating of  $I_{out}$  for different  $T_{AMB, MAX}$  for enclosure A, using SFAVM and maximum 10 m motor cable

**B enclosures**

For the B and C enclosures the derating also depends on the overload mode selected in par. 1-04

**60 PWM - Pulse Width Modulation**

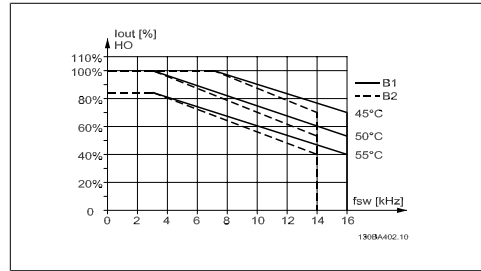

Illustration 4.5: Derating of  $I_{out}$  for different  $T_{AMB, MAX}$  for enclosure B, using 60 PWM in High torque mode (160% over torque)

**SFAVM - Stator Frequency Asyncon Vector Modulation**

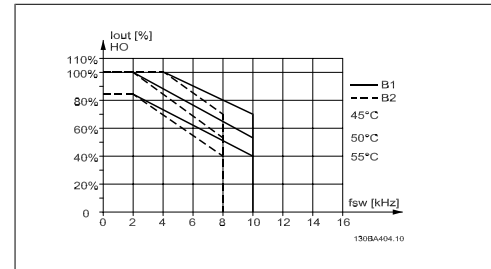

Illustration 4.6: Derating of  $I_{out}$  for different  $T_{AMB, MAX}$  for enclosure B, using SFAVM in High torque mode (160% over torque)

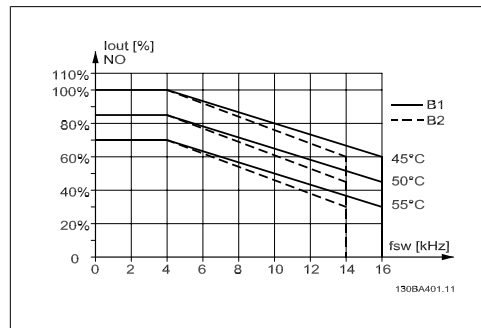

Illustration 4.7: Derating of  $I_{out}$  for different  $T_{AMB, MAX}$  for enclosure B, using 60 PWM in Normal torque mode (110% over torque)

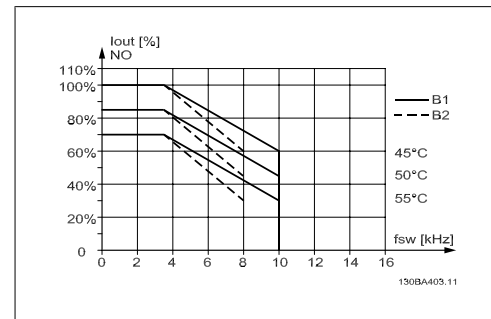

Illustration 4.8: Derating of  $I_{out}$  for different  $T_{AMB, MAX}$  for enclosure B, using SFAVM in Normal torque mode (110% over torque)

**C enclosures**

**60 PWM - Pulse Width Modulation**

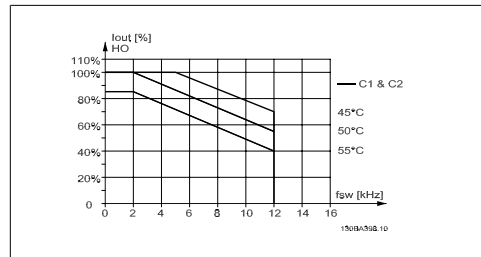

Illustration 4.9: Derating of  $I_{out}$  for different  $T_{AMB, MAX}$  for enclosure C, using 60 PWM in High torque mode (160% over torque)

**SFAVM - Stator Frequency Asyncon Vector Modulation**

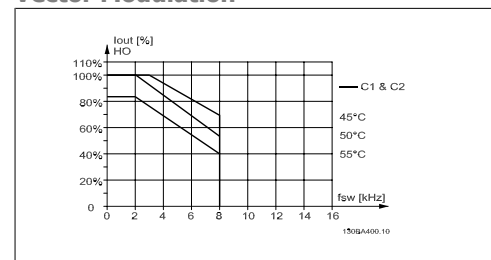

Illustration 4.10: Derating of  $I_{out}$  for different  $T_{AMB, MAX}$  for enclosure C, using SFAVM in High torque mode (160% over torque)

4

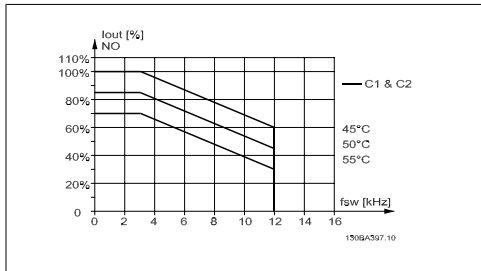

Illustration 4.11: Derating of I<sub>out</sub> for different T<sub>AMB</sub>, MAX for enclosure C, using 60 PWM in Normal torque mode (110% over torque)

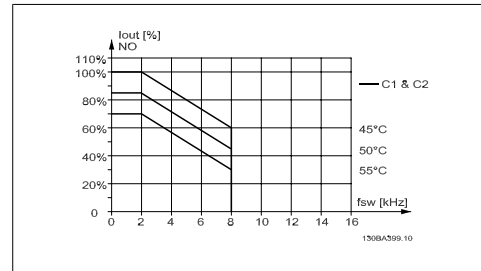

Illustration 4.12: Derating of I<sub>out</sub> for different T<sub>AMB</sub>, MAX for enclosure C, using SFAVM in Normal torque mode (110% over torque)

**D enclosures**

**60 PWM - Pulse Width Modulation, 380 - 500 V**

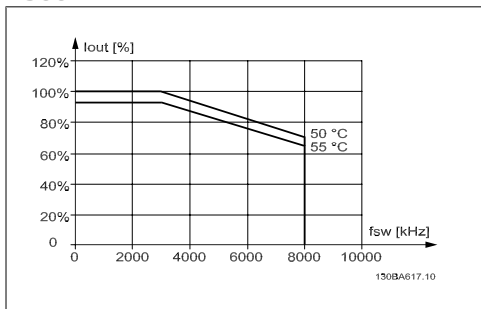

Illustration 4.13: Derating of I<sub>out</sub> for different T<sub>AMB</sub>, MAX for enclosure D at 500 V, using 60 PWM in High torque mode (160% over torque)

**SFAVM - Stator Frequency Asynchron Vector Modulation, 380 - 500 V**

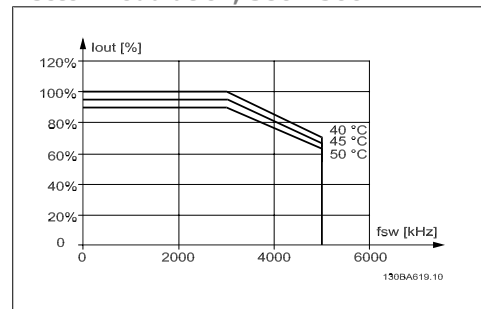

Illustration 4.14: Derating of I<sub>out</sub> for different T<sub>AMB</sub>, MAX for enclosure D at 500 V, using SFAVM in High torque mode (160% over torque)

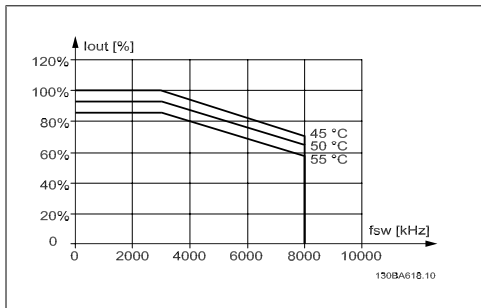

Illustration 4.15: Derating of I<sub>out</sub> for different T<sub>AMB</sub>, MAX for enclosure D at 500 V, using 60 PWM in Normal torque mode (110% over torque)

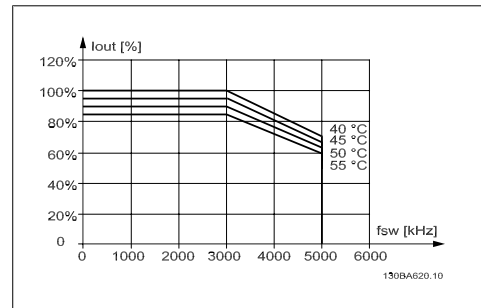

Illustration 4.16: Derating of I<sub>out</sub> for different T<sub>AMB</sub>, MAX for enclosure D at 500 V, using SFAVM in Normal torque mode (110% over torque)

**60 PWM - Pulse Width Modulation, 525 - 690 V (except P315)**

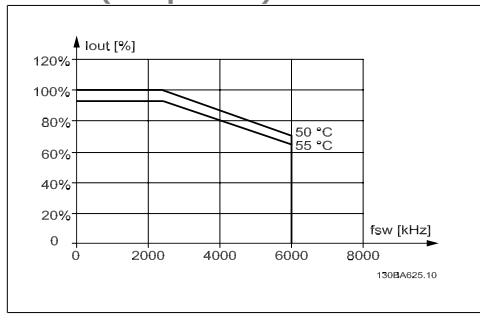

Illustration 4.17: Derating of  $I_{out}$  for different  $T_{AMB, MAX}$  for enclosure D at 690 V, using 60 PWM in High torque mode (160% over torque). Note: *not* valid for P315.

**SFAVM - Stator Frequency Asyncon Vector Modulation, 525 - 690 V (except P315)**

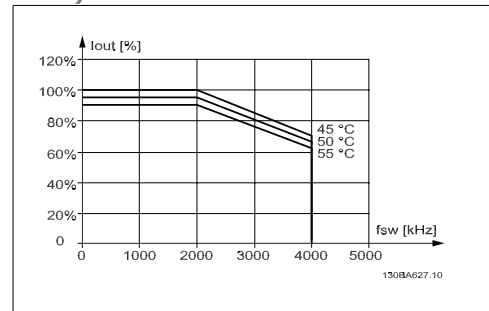

Illustration 4.18: Derating of  $I_{out}$  for different  $T_{AMB, MAX}$  for enclosure D at 690 V, using SFAVM in High torque mode (160% over torque). Note: *not* valid for P315.

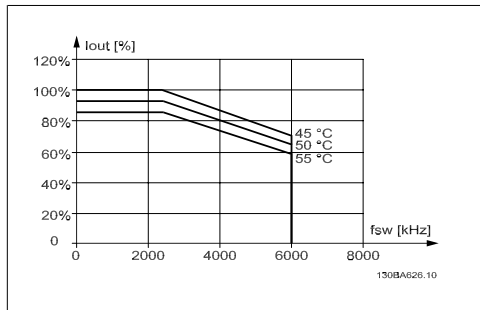

Illustration 4.19: Derating of  $I_{out}$  for different  $T_{AMB, MAX}$  for enclosure D at 690 V, using 60 PWM in Normal torque mode (110% over torque). Note: *not* valid for P315.

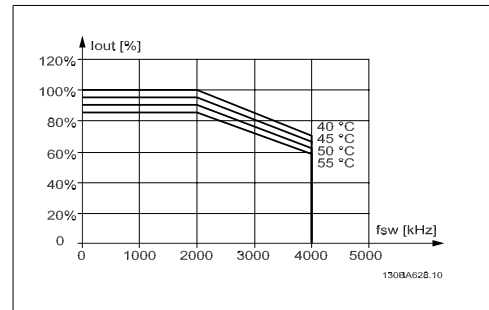

Illustration 4.20: Derating of  $I_{out}$  for different  $T_{AMB, MAX}$  for enclosure D at 690 V, using SFAVM in Normal torque mode (110% over torque). Note: *not* valid for P315.

**60 PWM - Pulse Width Modulation, 525 - 690 V, P315**

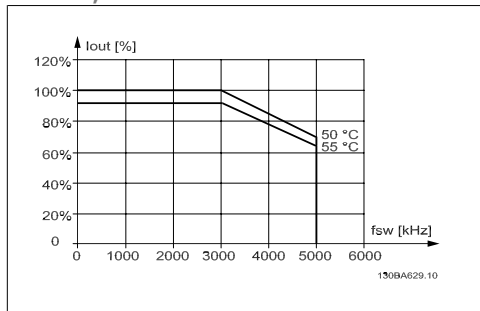

Illustration 4.21: Derating of  $I_{out}$  for different  $T_{AMB, MAX}$  for enclosure D at 690 V, using 60 PWM in High torque mode (160% over torque). Note: P315 *only*.

**SFAVM - Stator Frequency Asyncon Vector Modulation, 525 - 690 V, P315**

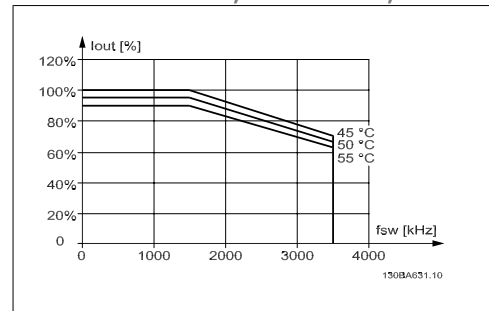

Illustration 4.22: Derating of  $I_{out}$  for different  $T_{AMB, MAX}$  for enclosure D at 690 V, using SFAVM in High torque mode (160% over torque). Note: P315 *only*.

4

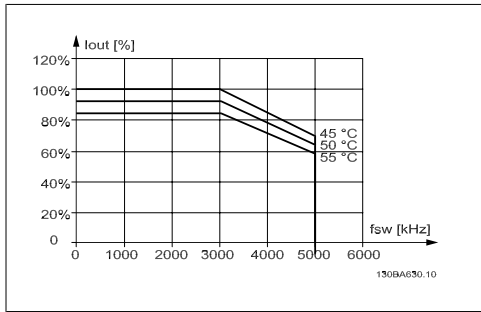

Illustration 4.23: Derating of I<sub>out</sub> for different T<sub>AMB, MAX</sub> for enclosure D at 690 V, using 60 PWM in Normal torque mode (110% over torque). Note: P315 *only*.

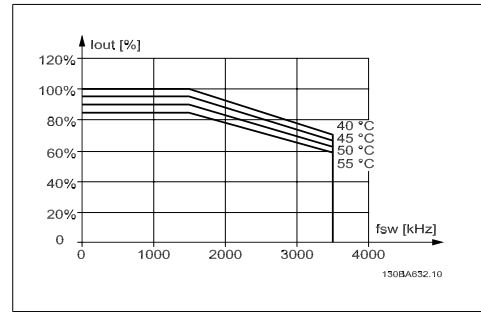

Illustration 4.24: Derating of I<sub>out</sub> for different T<sub>AMB, MAX</sub> for enclosure D at 690 V, using SFAVM in Normal torque mode (110% over torque). Note: P315 *only*.

**E enclosures**

**60 PWM - Pulse Width Modulation, 380 - 500 V**

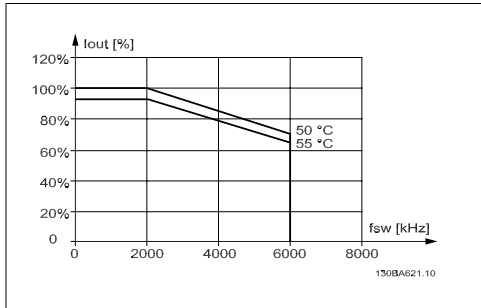

Illustration 4.25: Derating of I<sub>out</sub> for different T<sub>AMB, MAX</sub> for enclosure E at 500 V, using 60 PWM in High torque mode (160% over torque)

**SFAVM - Stator Frequency Asynchron Vector Modulation, 380 - 500 V**

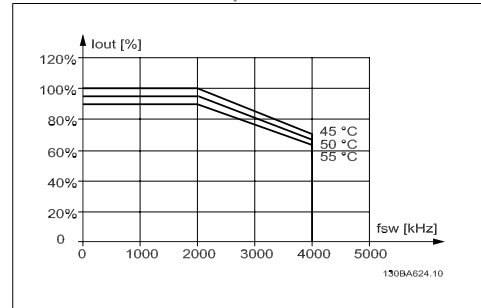

Illustration 4.26: Derating of I<sub>out</sub> for different T<sub>AMB, MAX</sub> for enclosure E at 500 V, using SFAVM in High torque mode (160% over torque).

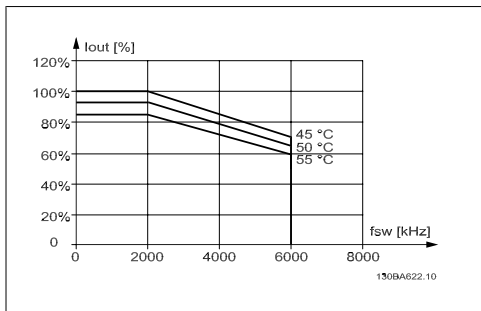

Illustration 4.27: Derating of I<sub>out</sub> for different T<sub>AMB, MAX</sub> for enclosure E at 500 V, using 60 PWM in Normal torque mode (110% over torque)

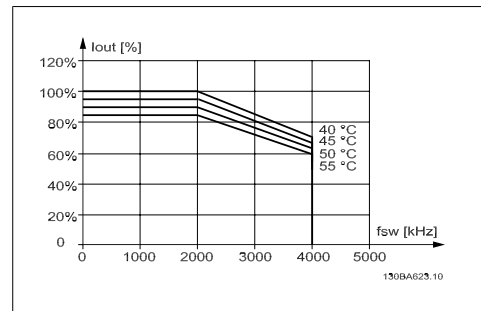

Illustration 4.28: Derating of I<sub>out</sub> for different T<sub>AMB, MAX</sub> for enclosure E at 500 V, using SFAVM in Normal torque mode (110% over torque)



**60 PWM - Pulse Width Modulation, 525 - 690 V**

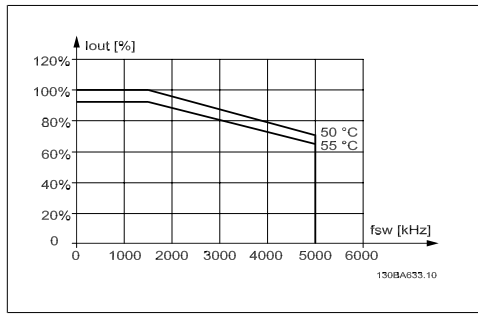

Illustration 4.29: Derating of  $I_{out}$  for different  $T_{AMB, MAX}$  for enclosure E at 690 V, using 60 PWM in High torque mode (160% over torque).

**SFAVM - Stator Frequency Asynchron Vector Modulation, 525 - 690 V**

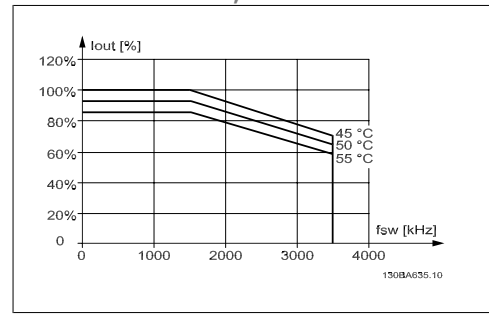

Illustration 4.30: Derating of  $I_{out}$  for different  $T_{AMB, MAX}$  for enclosure E at 690 V, using SFAVM in High torque mode (160% over torque).

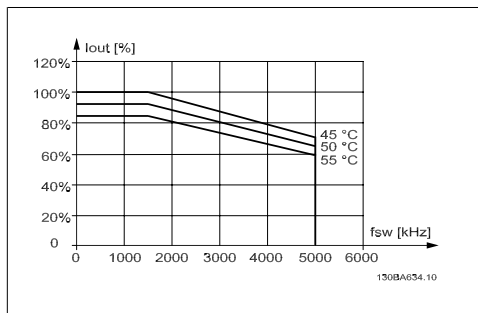

Illustration 4.31: Derating of  $I_{out}$  for different  $T_{AMB, MAX}$  for enclosure E at 690 V, using 60 PWM in Normal torque mode (110% over torque).

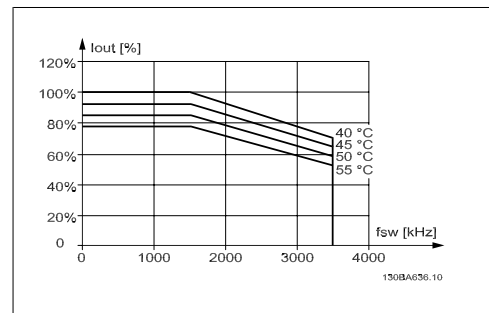

Illustration 4.32: Derating of  $I_{out}$  for different  $T_{AMB, MAX}$  for enclosure E at 690 V, using SFAVM in Normal torque mode (110% over torque).

**4.7.3. Derating for Low Air Pressure**

The cooling capability of air is decreased at lower air pressure.

Below 1000 m altitude no derating is necessary but above 1000 m the ambient temperature ( $T_{AMB}$ ) or max. output current ( $I_{out}$ ) should be derated in accordance with the shown diagram.

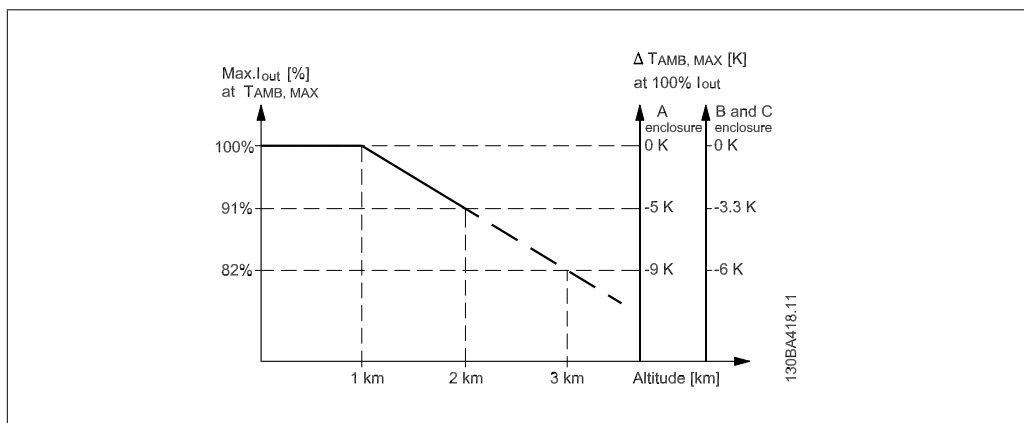

Illustration 4.33: Derating of output current versus altitude at  $T_{AMB, MAX}$ . By altitudes above 2 km, please contact Danfoss Drives regarding PELV.

An alternative is to lower the ambient temperature at high altitudes and thereby ensure 100% output current at high altitudes. As an example of how to read the graph, the situation at 2 km is elaborated. At a temperature of 45° C ( $T_{AMB, MAX} - 3.3 K$ ), 91% of the rated output current is available. At a temperature of 41.7° C, 100% of the rated output current is available.

#### 4.7.4. Derating for Running at Low Speed

When a motor is connected to a frequency converter, it is necessary to check that the cooling of the motor is adequate.

A problem may occur at low RPM values in constant torque applications. The motor fan may not be able to supply the required volume of air for cooling and this limits the torque that can be supported. Therefore, if the motor is to be run continuously at an RPM value lower than half of the rated value, the motor must be supplied with additional air-cooling (or a motor designed for this type of operation may be used).

An alternative is to reduce the load level of the motor by choosing a larger motor. However, the design of the frequency converter puts a limit to the motor size.

#### 4.7.5. Derating for Installing Long Motor Cables or Cables with Larger Cross-Section

The maximum cable length for FC 301 is 75 m unshielded and 50 m shielded cable. For FC302 it is 300 m unshielded and 150 m shielded

The frequency converter has been designed to work using a motor cable with a rated cross-section. If a cable with a larger cross-section is used, reduce the output current by 5% for every step the cross-section is increased.

(Increased cable cross-section leads to increased capacity to earth, and thus an increased earth leakage current).

#### 4.7.6. Automatic adaptations to ensure performance

The frequency converter constantly checks for critical levels of internal temperature, load current, high voltage on the intermediate circuit and low motor speeds. As a response to a critical level, the frequency converter can adjust the switching frequency and/ or change the switching pattern in order to ensure the performance of the drive.

# 5. How to Order

## 5.1.1. Drive Configurator

It is possible to design an FC 300 frequency converter according to the application requirements by using the ordering number system.

For the FC 300 Series, you can order standard drives and drives with integral options by sending a type code string describing the product to the local Danfoss sales office, i.e.:

FC-302PK75T5E20H1BGCXXXSXXXXA0BXCXXXXD0

The meaning of the characters in the string can be located in the pages containing the ordering numbers in the chapter *How to Select Your VLT*. In the example above, a Profibus DP V1 and a 24 V back-up option is included in the drive.

Ordering numbers for FC 300 standard variants can also be located in the chapter *How to Select Your VLT*.

From the Internet based Drive Configurator, you can configure the right drive for the right application and generate the type code string. The Drive Configurator will automatically generate an eight-digit sales number to be delivered to your local sales office.

Furthermore, you can establish a project list with several products and send it to a Danfoss sales representative.

The Drive Configurator can be found on the global Internet site: [www.danfoss.com/drives](http://www.danfoss.com/drives).

Drives will automatically be delivered with a language package relevant to the region from which it is ordered. Four regional language packages cover the following languages:

**Language package 1**

English, German, French, Danish, Dutch, Spanish, Swedish, Italian and Finnish.

**Language package 2**

English, German, Chinese, Korean, Japanese, Thai, Traditional Chinese and Bahasa Indonesian.

**Language package 3**

English, German, Slovenian, Bulgarian, Serbian, Romanian, Hungarian, Czech and Russian.

**Language package 4**

English, German, Spanish, English US, Greek, Brazilian Portuguese, Turkish and Polish.

To order drives with a different language package, please contact your local sales office.

## 5.1.2. Ordering Form Type Code

1	2	3	4	5	6	7	8	9	10	11	12	13	14	15	16	17	18	19	20	21	22	23	24	25	26	27	28	29	30	31	32	33	34	35	36	37	38	39
FC-	O	P					T																X	X	S	X	X	X	X	A	B	C					D	

130BA052.14

Product groups	1-3	
VLT series	4-6	
Power rating	8-10	
Phases	11	
Mains Voltage	12	
Enclosure	13-15	
Enclosure type		
Enclosure class		
Control supply voltage		
Hardware configuration		
RFI filter	16-17	
Brake	18	
Display (LCP)	19	
Coating PCB	20	
Mains option	21	
Adaptation A	22	
Adaptation B	23	
Software release	24-27	
Software language	28	
A options	29-30	
B options	31-32	
C0 options, MCO	33-34	
C1 options	35	
C option software	36-37	
D options	38-39	

Description	Pos	Possible choice
Product group	1-3	FC 30x
Drive series	4-6	FC 301 FC 302
Power rating	8-10	0.25-75 kW
Phases	11	Three phases (T)
Mains voltage	11-12	T 2: 200-240 V AC T 4: 380-480 V AC T 5: 380-500 V AC T 6: 525-600 V AC T 7: 690 V AC
Enclosure	14-15	E20: IP20 E21: IP 21/NEMA Type 1 E55: IP 55/NEMA Type 12 Z20: IP 20 <sup>1)</sup> Z21: IP 21 <sup>1)</sup> E66: IP 66
RFI filter	16-17	H1: RFI filter class A1/B1 H2: No RFI filter, observes class A2 H3: RFI filter class A1/B1 <sup>1)</sup> HX: No filter (600 V only)
Brake	18	B: Brake chopper included X: No brake chopper included T: Safe Stop No brake <sup>1)</sup> U: Safe stop brake chopper <sup>1)</sup>
Display	19	G: Graphical Local Control Panel (LCP) N: Numerical Local Control Panel (LCP) X: No Local Control Panel
Coating PCB	20	C: Coated PCB X: No coated PCB
Mains option	21	X: No mains option 1: Mains disconnect D: Load sharing <sup>2)</sup> 8: Mains disconnect and load Sharing <sup>2)</sup>
Adaptation	22	Reserved
Adaptation	23	Reserved
Software release	24-27	Actual software
Software language	28	
A options	29-30	A0: MCA 101 Profibus DP V1 A4: MCA 104 DeviceNet A6: MCA 105 CANOpen AX: No fieldbus
B options	31-32	BX: No option BK: MCB 101 General purpose I/O option BR: MCB 102 Encoder option BU: MCB 103 Resolver option BP: MCB 105 Relay option BZ: MCB 108 Safety PLC Interface
C0 options	33-34	CX: No option C4: MCO 305, Programmable Motion Controller.
C1 options	35	
C option software	36-37	
D options	38-39	DX: No option D0: DC back-up D0: MCB 107 Ext. 24 V back-up

1): FC 301/ A1 enclosure only  
2): Power sizes ≥ 11 kW only

Not all choices/options are available for each FC 301/FC 302 variant. To verify if the appropriate version is available, please consult the Drive Configurator on the Internet.

## 5.2.1. Ordering Numbers: Options and Accessories

Type	Description	Ordering no.	
<b>Miscellaneous hardware</b>			
DC link connector	Terminal block for DC link connection on frame size A2/A3	130B1064	
IP 21/4X top/TYPE 1 kit	Enclosure, frame size A1: IP21/IP 4X Top/TYPE 1	130B1121	
IP 21/4X top/TYPE 1 kit	Enclosure, frame size A2: IP21/IP 4X Top/TYPE 1	130B1122	
IP 21/4X top/TYPE 1 kit	Enclosure, frame size A3: IP21/IP 4X Top/TYPE 1	130B1123	
MCF 101	IP21/NEMA 1 enclosure Top Cover A2	130B1132	
MCF 101	IP21/NEMA 1 enclosure Top Cover A3	130B1133	
MCF 108	A5 IP55/ NEMA 12	130B1098	
MCF 108	B1 IP21/ IP55/ NEMA 12	130B3383	
MCF 108	B2 IP21/ IP55/ NEMA 12	130B3397	
MCF 108	C1 IP21/ IP55/ NEMA 12	130B3910	
MCF 108	C2 IP21/ IP55/ NEMA 12	130B3911	
MCF 108	A5 IP66/ NEMA 4x	130B3242	
MCF 108	B1 IP66/ NEMA 4x	130B3434	
MCF 108	B2 IP66/ NEMA 4x	130B3465	
MCF 108	C1 IP66/ NEMA 4x	130B3468	
MCF 108	C2 IP66/ NEMA 4x	130B3491	
Profibus D-Sub 9	D-Sub connector kit for IP20, frame sizes A1, A2 and A3	130B1112	
Profibus screen plate	Profibus screen plate kit for IP20, frame sizes A1, A2 and A3	130B0524	
Terminal blocks	Screw terminal blocks for replacing spring loaded terminals 1 pc 10 pin 1 pc 6 pin and 1 pc 3 pin connectors	130B1116	
USB Cable Extension for A5/ B1		130B1155	
USB Cable Extension for B2/ C1/ C2		130B1156	
Footmount frame for flat pack resistors, frame size A2		175U0085	
Footmount frame for flat pack resistors, frame size A3		175U0088	
Footmount frame for 2 flat pack resistors, frame size A2		175U0087	
Footmount frame for 2 flat pack resistors, frame size A3		175U0086	
<b>LCP</b>			
LCP 101	Numerical Local Control Panel (NLCP)	130B1124	
LCP 102	Graphical Local Control Panel (GLCP)	130B1107	
LCP cable	Separate LCP cable, 3 m	175Z0929	
LCP kit, IP21	Panel mounting kit including graphical LCP, fasteners, 3 m cable and gasket	130B1113	
LCP kit, IP21	Panel mounting kit including numerical LCP, fasteners and gasket	130B1114	
LCP kit, IP21	Panel mounting kit for all LCPs including fasteners, 3 m cable and gasket	130B1117	
<b>Options for Slot A</b>		<b>Uncoated</b>	<b>Coated</b>
MCA 101	Profibus option DP V0/V1	130B1100	130B1200
MCA 104	DeviceNet option	130B1102	130B1202
MCA 105	CANopen	130B1103	130B1205
MCA 113	Profibus VLT3000 protocol converter	130B1245	
<b>Options for Slot B</b>			
MCB 101	General purpose Input Output option	130B1125	130B1212
MCB 102	Encoder option	130B1115	130B1203
MCB 103	Resolver option	130B1127	130B1227
MCB 105	Relay option	130B1110	130B1210
MCB 108	Safety PLC interface (DC/DC Converter)	130B1120	130B1220
MCB 112	ATEX PTC Thermistor Card		130B1137
<b>Options for Slot C</b>			
MCO 305	Programmable Motion Controller	130B1134	130B1234
MCO 350	Synchronizing controller	130B1152	130B1252
MCO 351	Positioning controller	130B1153	120B1253
MCO 352	Center Winder Controller	130B1165	130B1166
Mounting kit for frame size A2 and A3		130B7530	-
Mounting kit for frame size A5		130B7532	-
Mounting kit for frame size B and C		130B7533	-
<b>Option for Slot D</b>			
MCB 107	24 V DC back-up	130B1108	130B1208
<b>External Options</b>			
Ethernet IP	Ethernet master	175N2584	-
<b>PC Software</b>			
MCT 10	MCT 10 set-up software - 1 user	130B1000	
MCT 10	MCT 10 set-up software - 5 users	130B1001	
MCT 10	MCT 10 set-up software - 10 users	130B1002	
MCT 10	MCT 10 set-up software - 25 users	130B1003	
MCT 10	MCT 10 set-up software - 50 users	130B1004	
MCT 10	MCT 10 set-up software - 100 users	130B1005	
MCT 10	MCT 10 set-up software - unlimited users	130B1006	
Options can be ordered as factory built-in options, see ordering information. For information on fieldbus and application option compatibility with older software versions, please contact your Danfoss supplier.			

Type	Description	Ordering no.	
<b>Spare Parts</b>			
Control board FC 302	Coated version	-	130B1109
Control board FC 301	Coated version	-	130B1126
Fan A2	Fan, frame size A2	130B1009	-
Fan A3	Fan, frame size A3	130B1010	-
Fan option C		130B7534	-
Backplate A5	Backplate A5 enclosures for	130B1098	
Connectors FC 300 Profibus	10 pieces Profibus connectors	130B1075	
Connectors FC 300 Device-	10 pieces DeviceNet connectors	130B1074	
Net			
Connectors FC 302 10 pole	10 pieces 10 pole spring loaded connectors	130B1073	
Connectors FC 301 8 pole	10 pieces 8 pole spring loaded connectors	130B1072	
Connectors FC 300 5 pole	10 pieces 5 pole spring loaded connectors	130B1071	
Connectors FC 300 RS485	10 pieces 3 pole spring loaded connectors for RS 485	130B1070	
Connectors FC 300 3 pole	10 pieces 3 pole connectors for relay 01	130B1069	
Connectors FC 302 3 pole	10 pieces 3 pole connectors for relay 02	130B1068	
Connectors FC 300 Mains	10 pieces mains connectors IP20/21	130B1067	
Connectors FC 300 Mains	10 pieces mains connectors IP 55	130B1066	
Connectors FC 300 Motor	10 pieces motor connectors	130B1065	
Connectors FC 300 Brake	10 pieces brake/load sharing connectors	130B1073	
DC bus			
Accessory bag A1	Accessory bag, frame size A1	130B1021	
Accessory bag A5	Accessory bag, frame size A5 (IP55)	130B1023	
Accessory bag A2	Accessory bag, frame size A2/A3	130B1022	
Accessory bag B1	Accessory bag, frame size B1	130B2060	
Accessory bag B2	Accessory bag, frame size B2	130B2061	
Accessory bag MCO 305		130B7535	

FC 301/302 Selected resistor																
Ordering Numbers: Brake Resistors																
Mains 200-240 V																
FC 301/ FC 302	P <sub>motor</sub>	R <sub>min</sub>	R <sub>br, nom</sub> <sup>c</sup>	Standard IP 20				Duty Cycle 40%				Aluminium Housed (Flatpack) IP65				
				R <sub>rec</sub>	P <sub>br max</sub>	Order no.	R <sub>rec</sub>	P <sub>br max</sub>	Order no.	R <sub>rec</sub> per item	Duty cycle	Order no.	FC 301	Max. torque load <sup>b</sup>		
	[kW]	[Ω]	[Ω]	[kW]	[kW]	[Ω]	[Ω]	[kW]	[kW]	[Ω]	[Ω]	[Ω]	%			
PK25	0.25	420	466.7	0.095	0.095	425	425	0.430	0.430	175Uxxxx	175Uxxxx	430Ω/100W	8	1002	145%	160%
PK37	0.37	284	315.3	0.250	0.250	310	310	0.800	0.800	1841	1941	310Ω/200W	16	0984	145%	160%
PK55	0.55	190	211.0	0.285	0.285	210	210	1.350	1.350	1842	1942	210Ω/200W	9	0987	145%	160%
PK75	0.75	139	154.0	0.065	0.065	145	145	0.260	0.260	1843	1943	150Ω/100W	14	1005	145%	160%
PK75	0.75	139	154.0	-	-	-	-	-	-	1820	1920	150Ω/100W	40	0989	145%	160%
PK11	1.1	90	104.4	0.095	0.095	90	90	0.430	0.430	-	-	100Ω/100W	8	1006	145%	160%
PK11	1.1	90	104.4	-	-	-	-	-	-	1821	1921	100Ω/100W	20	0991	145%	160%
PK15	1.5	65	75.7	0.250	0.250	65	65	0.800	0.800	1822	1922	72Ω/200W	16	0992	145%	160%
P2K2	2.2	46	51.0	0.285	0.285	50	50	1.00	1.00	1823	1923	50Ω/200W	9	0993	145%	160%
P3K0	3	33	37.0	0.430	0.430	35	35	1.35	1.35	1824	1924	35Ω/200W	5.5	0994	145%	160%
P3K0	3	33	37.0	-	-	-	-	-	-	-	-	72Ω/200W	12	2X0992 <sup>a</sup>	145%	160%
P3K7	3.7	25	29.6	0.800	0.800	25	25	3.00	3.00	1825	1925	60Ω/200W	13	2X0996 <sup>a</sup>	145%	160%

<sup>a</sup> Order two pieces, resistors must be connected in parallel.  
<sup>b</sup> Max. load with the resistor in Danfoss standard program.  
<sup>c</sup> R<sub>br, nom</sub> is the nominal (recommended) resistor value that ensures a brake power on motor shaft of 145% / 160% for 1 minute.

FC 301/302																
Selected resistor																
Ordering Numbers: Brake Resistors																
Mains 380-500 V / 380-480 V																
Standard IP 20				Duty Cycle 10%				Duty Cycle 40%				Aluminium Housed (Flatpack) IP65				
FC 301/ FC 302	P <sub>motor</sub>	R <sub>min</sub>	R <sub>br, nom</sub> <sup>c</sup>	R <sub>rec</sub>	P <sub>br, max</sub>	Order no.	R <sub>rec</sub>	P <sub>br, max</sub>	Order no.	R <sub>rec</sub>	P <sub>br, max</sub>	Order no.	R <sub>rec</sub> per item	Duty cycle	Order no.	Max. torque load <sup>b</sup>
	[kW]	[Ω]	[Ω]	[Ω]	[kW]	175Uxxxx	[Ω]	[kW]	175Uxxxx	[Ω]	[kW]	175Uxxxx	[Ω]	%	175Uxxxx	
PK37	0.37	620	1360.2	620	0.065	1840	620	0.065	1840	830	0.450	1976	830Ω/100W	20	1000	137%
PK55	0.55	620	915.0	620	0.065	1840	620	0.065	1840	830	0.450	1976	830Ω/100W	20	1000	160%
PK75	0.75	601	667.6	620	0.065	1840	620	0.260	1940	620	0.260	1940	620Ω/100W	14	1001	160%
PK75	0.75	601	667.6	-	-	-	-	-	-	-	-	-	620Ω/200W	40	0982	160%
P1K1	1.1	408	452.8	425	0.095	1841	425	0.430	1941	430	0.430	1941	430Ω/100W	8	1002	160%
P1K1	1.1	408	452.8	-	-	-	-	-	-	-	-	-	430Ω/200W	20	0983	160%
P1K5	1.5	297	330.4	310	0.250	1842	310	0.800	1942	310	0.800	1942	310Ω/200W	16	0984	160%
P2K2	2.2	200	222.6	210	0.285	1843	210	1.35	1943	210	1.35	1943	210Ω/200W	9	0987	160%
P3K0	3	145	161.4	150	0.430	1844	150	2.00	1944	150	2.00	1944	150Ω/200W	5.5	0989	160%
P3K0	3	145	161.4	-	-	-	-	-	-	-	-	-	300Ω/200W	12	2X0985 <sup>a</sup>	160%
P4K0	4	108	119.6	110	0.600	1845	110	2.40	1945	110	2.40	1945	240Ω/200W	11	2X0986 <sup>a</sup>	160%
P5K5	5.5	77	86.0	80	0.850	1846	80	3.00	1946	80	3.00	1946	160Ω/200W	6.5	2X0988 <sup>a</sup>	160%
P7K5	7.5	56	62.4	65	1.0	1847	65	4.50	1947	65	4.50	1947	130Ω/200W	4	2X0990 <sup>a</sup>	160%
P11K	11	38	42.1	40	1.8	1848	40	5.00	1948	40	5.00	1948	80Ω/240W	9	2X0090 <sup>a</sup>	160%
P15K	15	27	30.5	30	2.8	1849	30	9.30	1949	30	9.30	1949	72Ω/240W	6	2X0091 <sup>a</sup>	160%
P18K	18.5	22	24.5	25	3.5	1850	25	12.70	1950	25	12.70	1950	-	-	-	-
P22K	22	18	20.3	20	4.0	1851	20	13.00	1951	20	13.00	1951	-	-	-	-

<sup>a</sup> Order two pieces, resistors must be connected in parallel.

<sup>b</sup> Max. load with the resistor in Danfoss standard program.

<sup>c</sup> R<sub>br, nom</sub> is the nominal (recommended) resistor value that ensures a brake power on motor shaft of 137% / 160% for 1 minute.



## 5.2.2. Ordering Numbers: Harmonic Filters

Harmonic filters are used to reduce mains harmonics.

- AHF 010: 10% current distortion
- AHF 005: 5% current distortion

<b>380-415V, 50Hz</b>				
$I_{AHF,N}$	Typical Motor Used [kW]	Danfoss ordering number		Frequency converter size
		AHF 005	AHF 010	
10 A	4, 5.5	175G6600	175G6622	P4K0, P5K5
19 A	7.5	175G6601	175G6623	P5K5 - P7K5
26 A	11	175G6602	175G6624	P11K
35 A	15, 18.5	175G6603	175G6625	P15K, P18K
43 A	22	175G6604	175G6626	P22K
72 A	30, 37	175G6605	175G6627	P30K - P37K
101A	45, 55	175G6606	175G6628	P45K - P55K
144A	75	175G6607	175G6629	P75K
180A	90	175G6608	175G6630	P90K

<b>440-480V, 60Hz</b>				
$I_{AHF,N}$	Typical Motor Used [HP]	Danfoss ordering number		Frequency converter size
		AHF 005	AHF 010	
19 A	10, 15	175G6612	175G6634	P7K5
26 A	20	175G6613	175G6635	P15K
35 A	25, 30	175G6614	175G6636	P18K, P22K
43 A	40	175G6615	175G6637	P30K
72A	50, 60	175G6616	175G6638	P30K - P37K
101A	75	175G6617	175G6639	P45K - P55K
144A	100, 125	175G6618	175G6640	P75K - P90K

Matching the frequency converter and filter is pre-calculated based on 400V/480V and on a typical motor load (4 pole) and 110 % torque.

### 5.2.3. Ordering Numbers: Sine Wave Filter Modules, 200-500 VAC

Mains supply 3 x 200 to 500 V									
Frequency converter size			Minimum switching frequency	Maximum output frequency	Part No. IP20	Part No. IP00	Rated filter current at 50Hz		
200-240 V	380-440 V	440-500 V							
PK25	PK37	PK37	5 kHz	120 Hz	130B2439	130B2404	2.5 A		
PK37	PK55	PK55	5 kHz	120 Hz	130B2439	130B2404	2.5 A		
	PK75	PK75	5 kHz	120 Hz	130B2439	130B2404	2.5 A		
PK55	P1K1	P1K1	5 kHz	120 Hz	130B2441	130B2406	4.5 A		
	P1K5	P1K5	5 kHz	120 Hz	130B2441	130B2406	4.5 A		
PK75	P2K2	P2K2	5 kHz	120 Hz	130B2443	130B2408	8 A		
P1K1	P3K0	P3K0	5 kHz	120 Hz	130B2443	130B2408	8 A		
P1K5			5 kHz	120 Hz	130B2443	130B2408	8 A		
	P4K0	P4K0	5 kHz	120 Hz	130B2444	130B2409	10 A		
P2K2	P5K5	P5K5	5 kHz	120 Hz	130B2446	130B2411	17 A		
P3K0	P7K5	P7K5	5 kHz	120 Hz	130B2446	130B2411	17 A		
P4K0			5 kHz	120 Hz	130B2446	130B2411	17 A		
P5K5	P11K	P11K	4 kHz	60 Hz	130B2447	130B2412	24 A		
P7K5	P15K	P15K	4 kHz	60 Hz	130B2448	130B2413	38 A		
	P18K	P18K	4 kHz	60 Hz	130B2448	130B2413	38 A		
P11K	P22K	P22K	4 kHz	60 Hz	130B2307	130B2281	48 A		
P15K	P30K	P30K	3 kHz	60 Hz	130B2308	130B2282	62 A		
P18K	P37K	P37K	3 kHz	60 Hz	130B2309	130B2283	75 A		
P22K	P45K	P55K	3 kHz	60 Hz	130B2310	130B2284	115 A		
P30K	P55K	P75K	3 kHz	60 Hz	130B2310	130B2284	115 A		
P37K	P75K	P90K	3 kHz	60 Hz	130B2311	130B2285	180 A		
P45K	P90K	P110	3 kHz	60 Hz	130B2311	130B2285	180 A		
	P110	P132	3 kHz	60 Hz	130B2312	130B2286	260 A		
	P132	P160	3 kHz	60 Hz	130B2312	130B2286	260 A		
	P160	P200	3 kHz	60 Hz	130B2313	130B2287	410 A		
	P200	P250	3 kHz	60 Hz	130B2313	130B2287	410 A		
	P250	P315	3 kHz	60 Hz	130B2314	130B2288	480 A		
	P315	P355	2 kHz	60 Hz	130B2315	130B2289	660 A		
	P355	P400	2 kHz	60 Hz	130B2315	130B2289	660 A		
	P400	P450	2 kHz	60 Hz	130B2316	130B2290	750 A		
	P450	P500	2 kHz	60 Hz	130B2317	130B2291	880 A		
	P500	P560	2 kHz	60 Hz	130B2317	130B2291	880 A		
	P560	P630	2 kHz	60 Hz	130B2318	130B2292	1200 A		
	P630	P710	2 kHz	60 Hz	130B2318	130B2292	1200 A		

**NB!**

When using Sine-wave filters, the switching frequency should comply with filter specifications in *par. 14-01 Switching Frequency*.

## 5.2.4. Ordering Numbers: Sine-Wave Filter Modules, 525-690 VAC

Mains supply 3 x 525 to 690 V						
Frequency converter size		Minimum switching frequency	Maximum output frequency	Part No. IP20	Part No. IP00	Rated filter current at 50Hz
525-600V	690V					
PK75		2 kHz	60 Hz	130B2341	130B2321	13 A
P1K1		2 kHz	60 Hz	130B2341	130B2321	13 A
P1K5		2 kHz	60 Hz	130B2341	130B2321	13 A
P2k2		2 kHz	60 Hz	130B2341	130B2321	13 A
P3K0		2 kHz	60 Hz	130B2341	130B2321	13 A
P4K0		2 kHz	60 Hz	130B2341	130B2321	13 A
P5K5		2 kHz	60 Hz	130B2341	130B2321	13 A
P7K5		2 kHz	60 Hz	130B2341	130B2321	13 A
	P11K	2 kHz	60 Hz	130B2342	130B2322	28 A
P11K	P15K	2 kHz	60 Hz	130B2342	130B2322	28 A
P15K	P18K	2 kHz	60 Hz	130B2342	130B2322	28 A
P18K	P22K	2 kHz	60 Hz	130B2342	130B2322	28 A
P22K	P30K	2 kHz	60 Hz	130B2343	130B2323	45 A
P30K	P37K	2 kHz	60 Hz	130B2343	130B2323	45 A
P37K	P45K	2 kHz	60 Hz	130B2344	130B2324	76 A
P45K	P55K	2 kHz	60 Hz	130B2344	130B2324	76 A
P55K	P75K	2 kHz	60 Hz	130B2345	130B2325	115 A
P75K	P90K	2 kHz	60 Hz	130B2345	130B2325	115 A
P90K	P110	2 kHz	60 Hz	130B2346	130B2326	165 A
P110	P132	2 kHz	60 Hz	130B2346	130B2326	165 A
P150	P160	2 kHz	60 Hz	130B2347	130B2327	260 A
P180	P200	2 kHz	60 Hz	130B2347	130B2327	260 A
P220	P250	2 kHz	60 Hz	130B2348	130B2329	303 A
P260	P315	1.5 kHz	60 Hz	130B2270	130B2241	430 A
P300	P400	1.5 kHz	60 Hz	130B2270	130B2241	430 A
P375	P500	1.5 kHz	60 Hz	130B2271	130B2242	530 A
P450	P560	1.5 kHz	60 Hz	130B2381	130B2337	660 A
P480	P630	1.5 kHz	60 Hz	130B2381	130B2337	660 A
P560	P710	1.5 kHz	60 Hz	130B2382	130B2338	765 A
P670	P800	1.5 kHz	60 Hz	130B2383	130B2339	940 A
	P900	1.5 kHz	60 Hz	130B2383	130B2339	940 A
P820	P1M0	1.5 kHz	60 Hz	130B2384	130B2340	1320 A
P970	P1M2	1.5 kHz	60 Hz	130B2384	130B2340	1320 A



### NB!

When using Sine-wave filters, the switching frequency should comply with filter specifications in *par. 14-01 Switching Frequency*.



# 6. How to Install

## 6.1. Mechanical Dimension

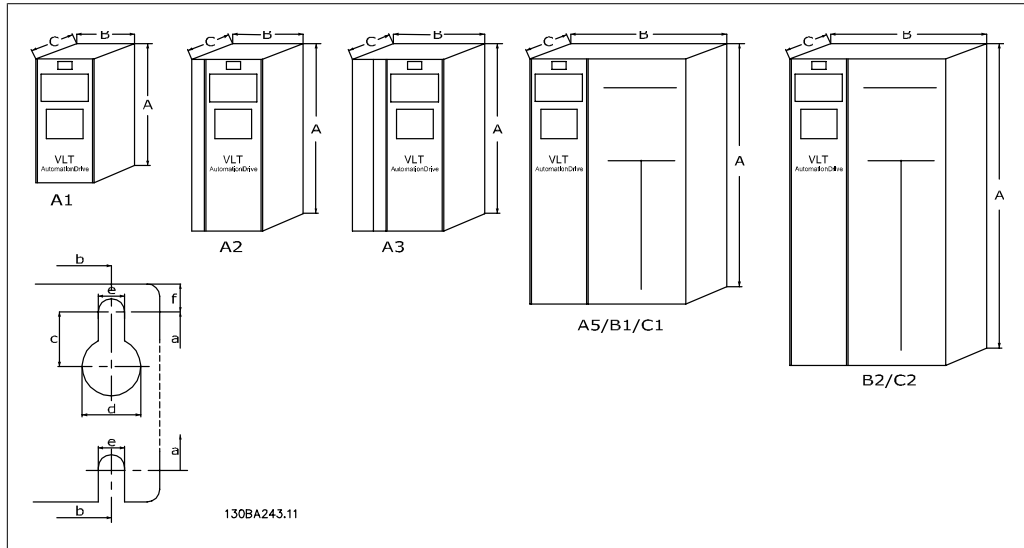

See the following tables for enclosure dimensions

Mechanical dimensions								
Frame size	A1		A2		A3		A5	
	0.25–1.5 kW (200-240 V) 0.37-1.5 kW (380-480 V)		0.25-3 kW (200-240 V) 0.37-4.0 kW (380-480/ 500 V) 0.75-4 kW (525-600 V)		3.7 kW (200-240 V) 5.5-7.5 kW (380-480/ 500 V) 5.5-7.5 kW (525-600 V)		0.25-3.7 kW (200-240 V) 0.37-7.5 kW (380-480/ 500 V) 0.75-7.5 kW (525-600 V)	
IP NEMA	20 Chassis	21 Type 1	20 Chassis	21 Type 1	20 Chassis	21 Type 1	55/66 Type 12	
<b>Height</b>								
Height of back plate	A	200 mm		268 mm	375 mm	268 mm	375 mm	420 mm
Height with de-coupling plate	A	316 mm	-	374 mm		374 mm	-	-
Distance between mounting holes	a	190 mm		257 mm	350 mm	257 mm	350 mm	402 mm
<b>Width</b>								
Width of back plate	B	75 mm		90 mm	90 mm	130 mm	130 mm	242 mm
Width of back plate with one C option	B			130 mm	130 mm	170 mm	170 mm	242 mm
Width of back plate with two C options	B			150 mm	150 mm	190 mm	190 mm	242 mm
Distance between mounting holes	b	60 mm		70 mm	70 mm	110 mm	110 mm	215 mm
<b>Depth</b>								
Depth without option A/B	C	205 mm		205 mm	205 mm	205 mm	205 mm	195 mm
With option A/B	C	220 mm		220 mm	220 mm	220 mm	220 mm	195 mm
Without option A/B	D*	207 mm			207 mm		207 mm	-
With option A/B	D*	222 mm			222 mm		222 mm	-
<b>Screw holes</b>								
	c	6.0 mm		8.0 mm	8.0 mm	8.0 mm	8.0 mm	8.25 mm
	d	ø8 mm		ø11 mm	ø11 mm	ø11 mm	ø11 mm	ø12 mm
	e	ø5 mm		ø5.5 mm	ø5.5 mm	ø5.5 mm	ø5.5 mm	ø6.5 mm
	f	5 mm		9 mm	9 mm	9 mm	9 mm	9 mm
<b>Max weight</b>		2.7 kg		4.9 kg	5.3 kg	6.6 kg	7.0 kg	13.5/14.2 kg

\* The front of the frequency converter is slightly convex. C is the shortest distance from back to front (i.e. measured from corner to corner) of the frequency converter. D is the longest distance from back to front (i.e. measured in the middle) of the frequency converter.

Mechanical dimensions					
Frame size		B1	B2	C1	C2
		5.5-7.5 kW (200-240 V) 11-15 kW (380-480/500 V)	11 kW (200-240 V) 18.5-22 kW (380-480/ 500 V)	15-22 kW (200-240 V) 30-45 kW (380-480/ 500 V)	30-37 kW (200-240 V) 55-75 kW (380-480/ 500 V)
IP NEMA		21/ 55/66 Type 1/Type 12	21/55/66 Type 1/Type 12	21/55/66 Type 1/Type 12	21/55/66 Type 1/Type 12
<b>Height</b>					
Height of back plate	A	480 mm	650 mm	680 mm	770 mm
Height with de-coupling plate	A	-	-		
Distance between mounting holes	a	454 mm	624 mm	648 mm	739 mm
<b>Width</b>					
Width of back plate	B	242 mm	242 mm	308 mm	370 mm
Width of back plate with one C option	B	242 mm	242 mm	308 mm	370 mm
Width of back plate with two C options	B	242 mm	242 mm	308 mm	370 mm
Distance between mounting holes	b	210 mm	210 mm	272 mm	334 mm
<b>Depth</b>					
Depth without option A/B	C	260 mm	260 mm	310 mm	335 mm
With option A/B	C	260 mm	260 mm	310 mm	335 mm
Without option A/B	D*	-	-	-	-
With option A/B	D*	-	-	-	-
<b>Screw holes</b>					
	c	12 mm	12 mm	12 mm	12 mm
	d	ø19 mm	ø19 mm	ø19 mm	ø19 mm
	e	ø9 mm	ø9 mm	ø9.8 mm	ø9.8 mm
	f	9 mm	9 mm	17.6 mm	18 mm
<b>Max weight</b>		23 kg	27 kg	43 kg	61 kg

\* The front of the frequency converter is slightly convex. C is the shortest distance from back to front (i.e. measured from corner to corner) of the frequency converter. D is the longest distance from back to front (i.e. measured in the middle) of the frequency converter.



Mechanical dimensions , D Enclosures							
Frame size		D1		D2		D3	D4
		90 - 110 kW (380 - 500 V) 110 - 132 kW (525-690 V)		132 - 200 kW (380 - 500 V) 160 - 315 kW (525-690 V)		90 - 110 kW (380 - 500 V) 110 - 132 kW (525-690 V)	132 - 200 kW (380 - 500 V) 160 - 315 kW (525-690 V)
IP NEMA		21 Type 1	54 Type 12	21 Type 1	54 Type 12	00 Chassis	00 Chassis
Card board box size Shipping dimen- sions	Height		650 mm	650 mm	650 mm	650 mm	650 mm
	Width		1730 mm	1730 mm	1730 mm	1220 mm	1490 mm
	Depth		570 mm	570 mm	570 mm	570 mm	570 mm
Drive di- mensions	Height		1159 mm	1159 mm	1540 mm	1540 mm	997 mm
	Width		420 mm	420 mm	420 mm	420 mm	408 mm
	Depth		373 mm	373 mm	373 mm	373 mm	373 mm
	Max weight		104 kg	104 kg	151 kg	151 kg	91 kg

Mechanical dimensions, E Enclosures					
Frame size		E1		E2	
		250 - 400 kW (380 - 500 V) 355 - 560 kW (525-690 V)		250 - 400 kW (380 - 500 V) 355 - 560 kW (525-690 V)	
IP NEMA		21 Type 12	54 Type 12	00 Chassis	
Card board box size Shipping dimensions	Height		840 mm	840 mm	831 mm
	Width		2197 mm	2197 mm	1705 mm
	Depth		736 mm	736 mm	736 mm
Drive dimensions	Height		2000 mm	2000 mm	1499 mm
	Width		600 mm	600 mm	585 mm
	Depth		494 mm	494 mm	494 mm
	Max weight		313 kg	313 kg	277 kg



## 6.2. Mechanical Installation

### 6.2.1. Accessory Bag

Find the following parts included in the FC 100/ 300 Accessory Bag.

130BT309.11

1 2

Frame sizes A1, A2 and A3  
IP20/Chassis

130BT339.10

1 2

Frame size A5  
IP55/Type 12

130BT330

Frame sizes B1 and B2  
IP21/IP55/Type 1/Type 12

130BA406.10

Frame sizes C1 and C2  
IP55/66/Type 1/Type 12

1 + 2 only available in units with brake chopper. Only one relay connector is included for FC 101/301 units. For DC link connection (Load sharing) the connector 1 can be ordered separately (Code no 130B1064)  
An eight pole connector is included in accessory bag for FC 101/301 without Safe Stop.

## 6.2.2. Mechanical mounting

FC 300 IP20 Frame sizes A1, A2 and A3 as well as IP21/ IP55 Frame sizes A5, B1, B2, C1 and C2 allow side-by-side installation.

If the IP 21 Enclosure kit (130B1122 or 130B1123) is used there must be a clearance between the drives of min 50 mm.

For optimal cooling conditions allow a free air passage above and below the frequency converter. See table below.

Air passage for different enclosures	
Enclosure:	A1    A2    A3    A5    B1    B2    C1    C2
a (mm):	100    100    100    100    100    100    200    225
b (mm):	100    100    100    100    100    100    200    225

1. Drill holes in accordance with the measurements given.
2. You must provide screws suitable for the surface on which you want to mount the FC 300. Retighten all four screws.

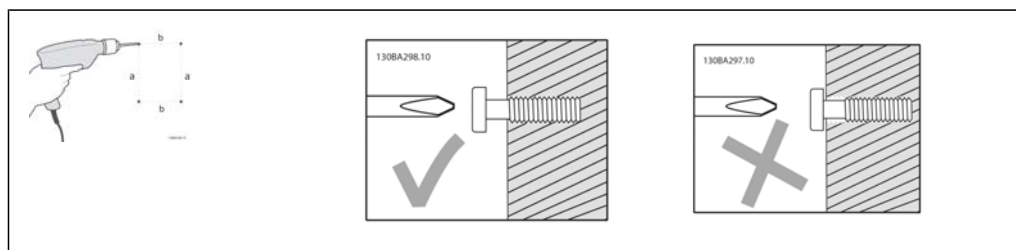

Mounting frame sizes A1, A2 and A3:

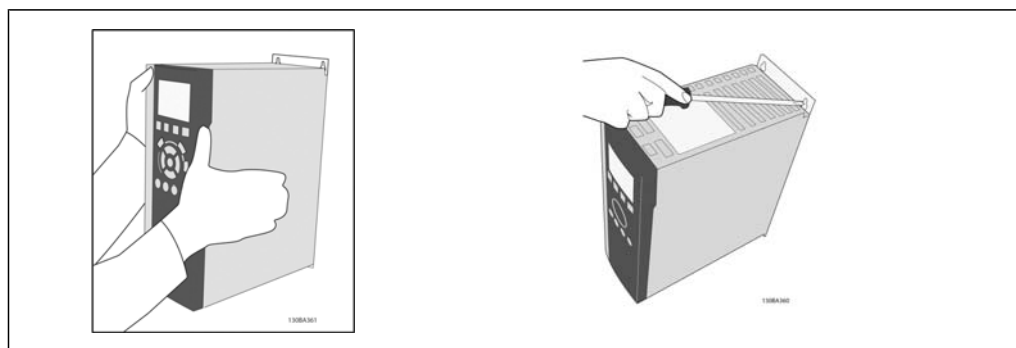

Mounting frame sizes A5, B1, B2, C1 and C2: The back wall must always be solid for optimum cooling.

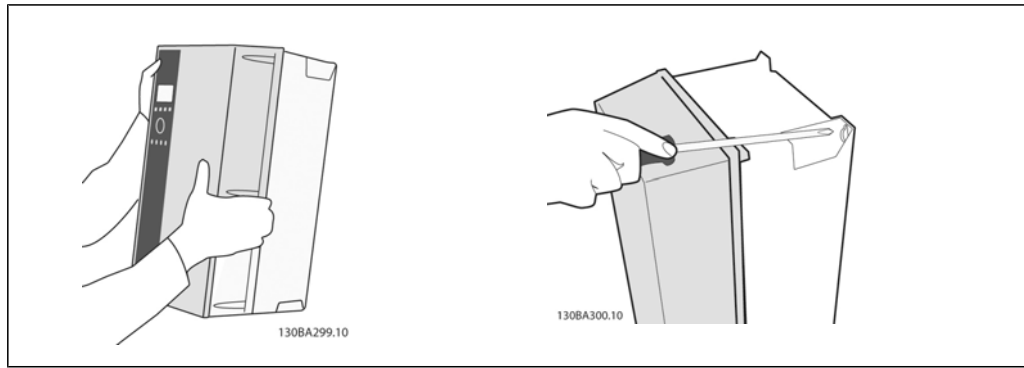

Mounting frame sizes A5, B1, B2, C1 and C2 on a non-solid back wall, the drive must be

provided with a back plate A due to insufficient cooling air over the heat sink.

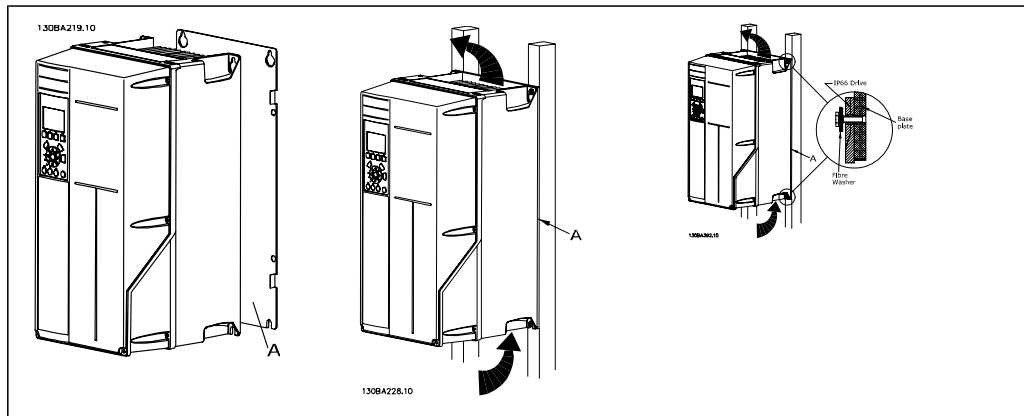

### 6.2.3. Safety Requirements of Mechanical Installation



Pay attention to the requirements that apply to integration and field mounting kit. Observe the information in the list to avoid serious damage or injury, especially when installing large units.

The frequency converter is cooled by means of air circulation.

To protect the unit from overheating, it must be ensured that the ambient temperature *does not exceed the maximum temperature stated for the frequency converter* and that the 24-hour average temperature *is not exceeded*. Locate the maximum temperature and 24-hour average in the paragraph *Derating for Ambient Temperature*.

If the ambient temperature is in the range of 45 °C - 55 °C, derating of the frequency converter will become relevant, see *Derating for Ambient Temperature*.

The service life of the frequency converter is reduced if derating for ambient temperature is not taken into account.

6

### 6.2.4. Field Mounting

For field mounting the IP 21/IP 4X top/TYPE 1 kits or IP 54/55 units are recommended.

## 6.3. Electrical Installation



**NB!**  
**Cables General**

All cabling must comply with national and local regulations on cable cross-sections and ambient temperature. Copper (60/75°C) conductors are recommended.

#### Aluminium Conductors

Terminals can accept aluminium conductors but the conductor surface has to be clean and the oxidation must be removed and sealed by neutral acid-free Vaseline grease before the conductor is connected.

Furthermore the terminal screw must be retightened after two days due to softness of the aluminium. It is crucial to keep the connection a gas tight joint, otherwise the aluminium surface will oxidize again.

Tightening-up Torque					
FC size	200 - 240 V	380 - 500 V	525 - 690 V	Cable for:	Tightening up torque
A1	0.25-1.5 kW	0.37-1.5 kW	-	Line, Brake resistor, load sharing, Motor cables	0.5-0.6 Nm
A2	0.25-2.2 kW	0.37-4 kW	0.75-4 kW		
A3	3-3.7 kW	5.5-7.5 kW	5.5-7.5 kW		
A5	3-3.7 kW	5.5-7.5 kW	0.75-7.5 kW		
B1	5.5-7.5 kW	11-15 kW	-		
B2	11 kW	18.5-22 kW	-	Line, Brake resistor, load sharing, Motor cables	1.8 Nm
				Relay	0.5-0.6 Nm
				Earth	2-3 Nm
				Line, Brake resistor, load sharing cables	4.5 Nm
C1	15-22 kW	30-45 kW	-	Motor cables	4.5 Nm
				Relay	0.5-0.6 Nm
				Earth	2-3 Nm
				Line, Brake resistor, load sharing cables	10 Nm
C2	30-37 kW	55-75 kW	-	Motor cables	10 Nm
				Relay	0.5-0.6 Nm
				Earth	2-3 Nm
				Line, Brake resistor, load sharing cables	14 Nm
D1, D3	-	90-110 kW	110-132 kW	Motor cables	10 Nm
				Load Sharing, brake cables	9.5 Nm
				Relay	0.5-0.6 Nm
				Earth	19 Nm
D2, D4	-	132-200 kW	160-315 kW	Line, motor cables	19 Nm
				Load Sharing, brake cables	9.5 Nm
				Relay	0.5-0.6 Nm
				Earth	19 Nm
E1, E2	-	250-400 kW	355-560 kW	Line, motor cables	19 Nm
				Load Sharing, brake cables	9.5 Nm
				Relay	0.5-0.6 Nm
				Earth	19 Nm

### 6.3.1. Removal of Knockouts for Extra Cables

1. Remove cable entry from the frequency converter (Avoiding foreign parts falling into the frequency converter when removing knockouts)
2. Cable entry has to be supported around the knockout you intend to remove.
3. The knockout can now be removed with a strong mandrel and a hammer.
4. Remove burrs from the hole.
5. Mount Cable entry on frequency converter.

### 6.3.2. Connection to Mains and Earthing

**NB!** The plug connector for power is pluggable on FC 300 up to 7.5 kW.

1. Fit the two screws in the de-coupling plate, slide it into place and tighten the screws.

2. Make sure the FC 300 is properly earthed. Connect to earth connection (terminal 95). Use screw from the accessory bag.
3. Place plug connector 91(L1), 92(L2), 93(L3) from the accessory bag onto the terminals labelled MAINS at the bottom of FC 300.
4. Attach mains wires to the mains plug connector.
5. Support the cable with the supporting enclosed brackets.

 **NB!**  
Check that mains voltage corresponds to the mains voltage of the FC 300 name plate.

 **IT Mains**  
Do not connect 400 V frequency converters with RFI-filters to mains supplies with a voltage between phase and earth of more than 440 V.

 The earth connection cable cross section must be at least 10 mm<sup>2</sup> or 2 x rated mains wires terminated separately according to EN 50178.

The mains connection is fitted to the mains switch if this is included.

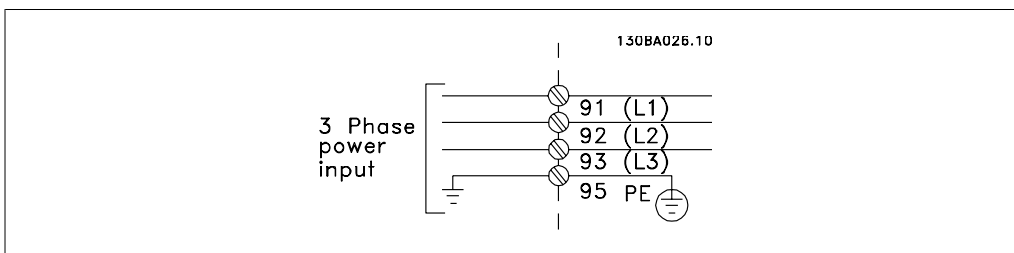

Mains connection for frame sizes A1, A2 and A3:

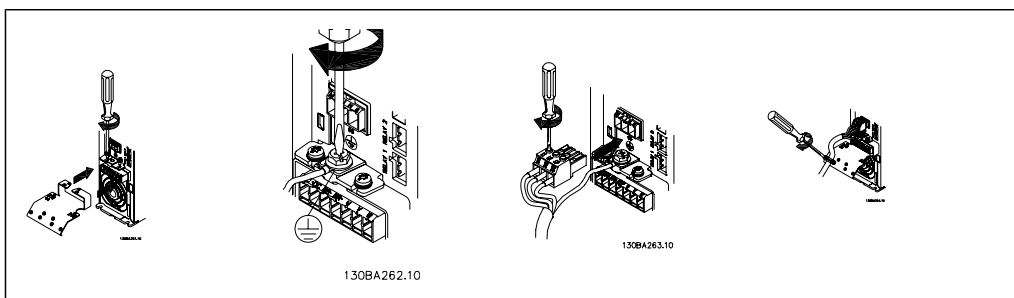

Mains connector A5 (IP 55/66) Enclosure

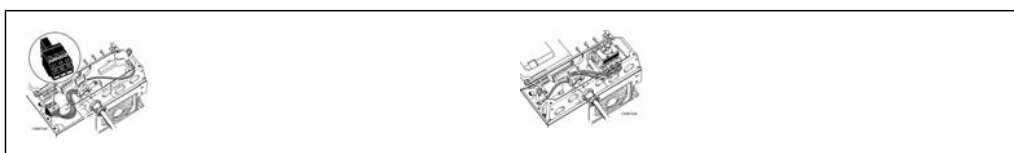

When disconnector is used (A5 enclosure) the PE must be mounted on the left side of the drive.

Mains connection B1 and B2 (IP 21/NEMA Type 1 and IP 55/66/ NEMA Type 12) enclosures

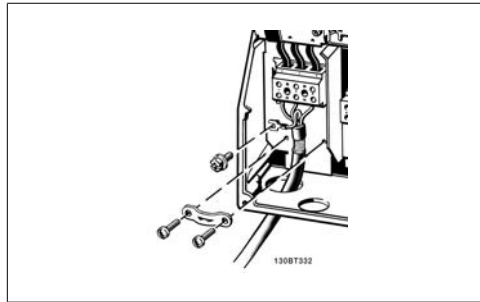

Mains connection C1 and C2 (IP 21/ NEMA Type 1 and IP 55/66/ NEMA Type 12) enclosures

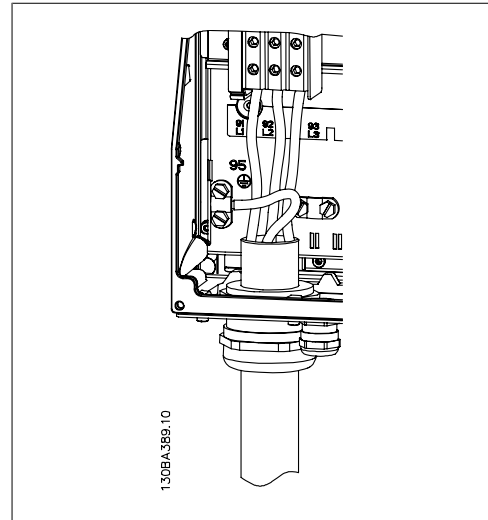

Usually the power cables for mains are unshielded cables.

### 6.3.3. Motor Connection

**NB!** Motor cable must be screened/armoured. If an unshielded/unarmoured cable is used, some EMC requirements are not complied with. Use a screened/armoured motor cable to comply with EMC emission specifications. For more information, see *EMC Test Results*.

See section General Specifications for correct dimensioning of motor cable cross-section and length.

**Screening of cables:** Avoid installation with twisted screen ends (pigtailed). They spoil the screening effect at higher frequencies. If it is necessary to break the screen to install a motor isolator or motor contactor, the screen must be continued at the lowest possible HF impedance.

Connect the motor cable screen to both the decoupling plate of the FC 300 and to the metal housing of the motor.

Make the screen connections with the largest possible surface area (cable clamp). This is done by using the supplied installation devices in the FC 300.

If it is necessary to split the screen to install a motor isolator or motor relay, the screen must be continued with the lowest possible HF impedance.

**Cable-length and cross-section:** The frequency converter has been tested with a given length of cable and a given cross-section of that cable. If the cross-section is increased, the cable capacitance - and thus the leakage current - may increase, and the cable length must be reduced correspondingly. Keep the motor cable as short as possible to reduce the noise level and leakage currents.

**Switching frequency:** When frequency converters are used together with Sine-wave filters to reduce the acoustic noise from a motor, the switching frequency must be set according to the Sine-wave filter instruction in Par. 14-01.

1. Fasten decoupling plate to the bottom of FC 300 with screws and washers from the accessory bag.
2. Attach motor cable to terminals 96 (U), 97 (V), 98 (W).
3. Connect to earth connection (terminal 99) on decoupling plate with screws from the accessory bag.
4. Insert plug connectors 96 (U), 97 (V), 98 (W) (up to 7.5 kW) and motor cable to terminals labelled MOTOR.
5. Fasten screened cable to decoupling plate with screws and washers from the accessory bag.

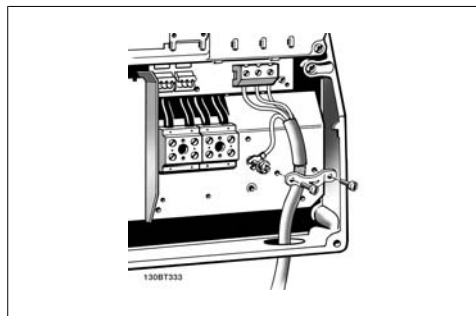

Illustration 6.3: Motor connection for B1 and B2 (IP 21/ NEMA Type 1, IP 55/ NEMA Type 12 and IP66/ NEMA Type 4X) enclosure

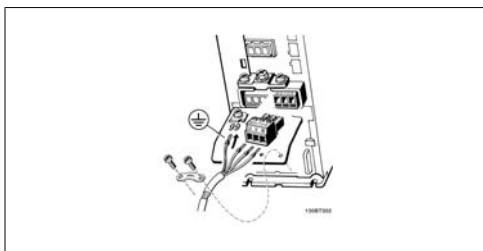

Illustration 6.1: Motor connection for A1, A2 and A3

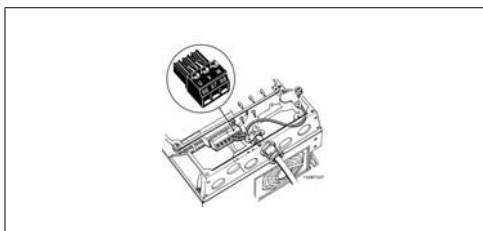

Illustration 6.2: Motor connection for A5 (IP 55/66/NEMA Type 12) enclosure

All types of three-phase asynchronous standard motors can be connected to the FC 300. Normally, small motors are star-connected (230/400 V, Y). Large motors are normally delta-connected (400/690 V,  $\Delta$ ). Refer to the motor name plate for correct connection mode and voltage.

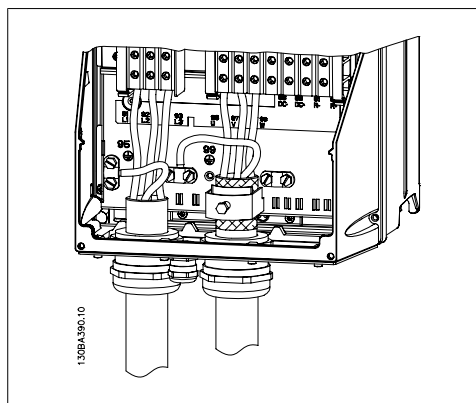

Illustration 6.4: Motor connection C1 and C2 (IP 21/ NEMA Type 1 and IP 55/66/ NEMA Type 12) enclosure



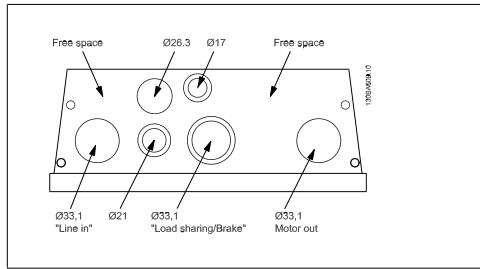

Illustration 6.5: Cable entry holes for enclosure B1. The suggested use of the holes are purely recommendations and other solutions are possible.

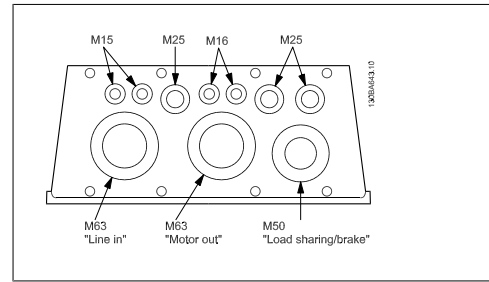

Illustration 6.7: Cable entry holes for enclosure C1. The suggested use of the holes are purely recommendations and other solutions are possible.

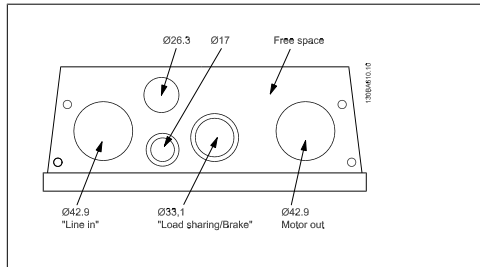

Illustration 6.6: Cable entry holes for enclosure B2. The suggested use of the holes are purely recommendations and other solutions are possible.

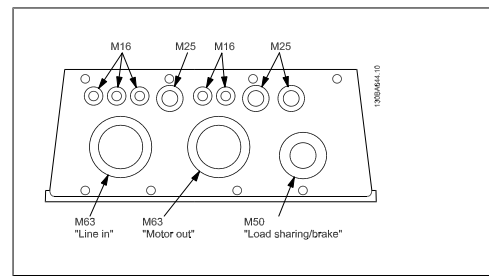
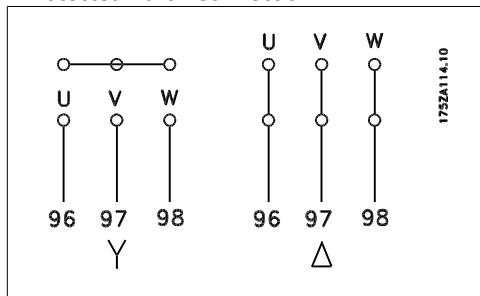

Illustration 6.8: Cable entry holes for enclosure C2. The suggested use of the holes are purely recommendations and other solutions are possible.

Term. no.	96	97	98	99	
	U	V	W	PE <sup>1)</sup>	Motor voltage 0-100% of mains voltage. 3 wires out of motor
	U1	V1	W1	PE <sup>1)</sup>	Delta-connected
	W2	U2	V2		6 wires out of motor
	U1	V1	W1	PE <sup>1)</sup>	Star-connected U2, V2, W2 U2, V2 and W2 to be interconnected separately.

<sup>1)</sup>Protected Earth Connection



**NB!**  
When using motors without phase insulation paper or other insulation reinforcement suitable for operation with voltage supplied from frequency converters, fit a sine-wave filter on the output of the FC 300.

### 6.3.4. Fuses

**Branch circuit protection:**

In order to protect the installation against electrical and fire hazard, all branch circuits in an installation, switch gear, machines etc., must be short-circuited and overcurrent protected according to national/international regulations.

**Short-circuit protection:**

The frequency converter must be protected against short-circuit to avoid electrical or fire hazard. Danfoss recommends using the fuses mentioned below to protect service personnel and equip-

ment in case of an internal failure in the drive. The frequency converter provides full short-circuit protection in case of a short-circuit on the motor output.

#### Overcurrent protection:

Provide overload protection to avoid fire hazard due to overheating of the cables in the installation. The frequency converter is equipped with an internal overcurrent protection that can be used for upstream overload protection (UL-applications excluded). See par. 4-18. Moreover, fuses or circuit breakers can be used to provide the overcurrent protection in the installation. Overcurrent protection must always be carried out according to national regulations.

Fuses must be designed for protection in a circuit capable of supplying a maximum of 100,000  $A_{rms}$  (symmetrical), 500 V maximum.

#### Non UL compliance

If UL/cUL is not to be complied with, we recommend using the following fuses, which will ensure compliance with EN50178:

In case of malfunction, not following the recommendation may result in unnecessary damage to the frequency converter.

FC 300	Max. fuse size <sup>1)</sup>	Voltage	Type
K25- K75	10A	200-240 V	type gG
1K1-2K 2	20A	200-240 V	type gG
3K0-3K 7	32A	200-240 V	type gG
5K5-7K 5	63A	380-500 V	type gG
11K	80A	380-500 V	type gG
15K-18 K5	125A	380-500 V	type gG
22K	160A	380-500 V	type aR
30K	200A	380-500 V	type aR
37K	250A	380-500 V	type aR

FC 300	Max. fuse size <sup>1)</sup>	Voltage	Type
K37-1K 5	10A	380-500 V	type gG
2K2-4K 0	20A	380-500 V	type gG
5K5-7K 5	32A	380-500 V	type gG
11K-18 K	63A	380-500 V	type gG
22K	80A	380-500 V	type gG
30K	100A	380-500 V	type gG
37K	125A	380-500 V	type gG
45K	160A	380-500 V	type aR
55K-75 K	250A	380-500 V	type aR

1) Max. fuses - see national/international regulations for selecting an applicable fuse size.

#### UL Compliance

##### 200-240 V

FC 300	Bussmann	Bussmann	Bussmann	SIBA	Littel fuse	Ferraz-Shawmut	Ferraz-Shawmut
kW	Type RK1	Type J	Type T	Type RK1	Type RK1	Type CC	Type RK1
K25-K75	KTN-R10	JKS-10	JJN-10	5017906-01 0	KLN-R10	ATM-R10	A2K-10R
1K1-2K2	KTN-R20	JKS-20	JJN-20	5017906-02 0	KLN-R20	ATM-R20	A2K-20R
3K0-3K7	KTN-R30	JKS-30	JJN-30	5012406-03 2	KLN-R30	ATM-R30	A2K-30R
5K5	KTN-R50	KS-50	JJN-50	5014006-05 0	KLN-R50		A2K-50R
7K5	KTN-R60	JKS-60	JJN-60	5014006-06 3	KLN-R60		A2K-60R
11K	KTN-R80	JKS-80	JJN-80	5014006-08 0	KLN-R80		A2K-80R
15K-18K 5	KTN-R125	JKS-150	JJN-125	2028220-12 5	KLN-R125		A2K-125R
22K	FWX-150	---	---	2028220-15 0	L25S-150		A25X-150
30K	FWX-200	---	---	2028220-20 0	L25S-200		A25X-200
37K	FWX-250	---	---	2028220-25 0	L25S-250		A25X-250

### 380-500 V, 525-600 V

FC 300	Bussmann	Bussmann	Bussmann	SIBA	Littel fuse	Ferraz-Shawmut	Ferraz-Shawmut
kW	Type RK1	Type J	Type T	Type RK1	Type RK1	Type CC	Type RK1
K37-1K 5	KTS-R10	JKS-10	JJS-10	5017906-01 0	KLS-R10	ATM-R10	A6K-10R
2K2-4K 0	KTS-R20	JKS-20	JJS-20	5017906-02 0	KLS-R20	ATM-R20	A6K-20R
5K5-7K 5	KTS-R30	JKS-30	JJS-30	5012406-03 2	KLS-R30	ATM-R30	A6K-30R
11K	KTS-R40	JKS-40	JJS-40	5014006-04 0	KLS-R40		A6K-40R
15K	KTS-R50	JKS-50	JJS-50	5014006-05 0	KLS-R50		A6K-50R
18K	KTS-R60	JKS-60	JJS-60	5014006-06 3	KLS-R60		A6K-60R
22K	KTS-R80	JKS-80	JJS-80	2028220-10 0	KLS-R80		A6K-80R
30K	KTS-R100	JKS-100	JJS-100	2028220-12 5	KLS-R100		A6K-100R
37K	KTS-R125	JKS-150	JJS-150	2028220-12 5	KLS-R125		A6K-125R
45K	KTS-R150	JKS-150	JJS-150	2028220-15 0	KLS-R150		A6K-150R
55K	FWH-220	-	-	2028220-20 0	L50S-225		A50-P225
75K	FWH-250	-	-	2028220-25 0	L50S-250		A50-P250

KTS-fuses from Bussmann may substitute KTN for 240 V frequency converters.

FWH-fuses from Bussmann may substitute FWX for 240 V frequency converters.

KLSR fuses from LITTEL FUSE may substitute KLNLR fuses for 240 V frequency converters.

L50S fuses from LITTEL FUSE may substitute L50S fuses for 240 V frequency converters.

A6KR fuses from FERRAZ SHAWMUT may substitute A2KR for 240 V frequency converters.

A50X fuses from FERRAZ SHAWMUT may substitute A25X for 240 V frequency converters.

### 6.3.5. Access to Control Terminals

All terminals to the control cables are located underneath the terminal cover on the front of the frequency converter. Remove the terminal cover by means of a screwdriver (see illustration).

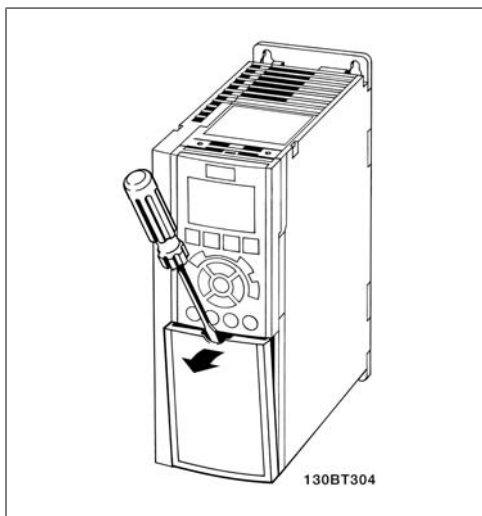

Illustration 6.9: A1, A2 and A3 enclosures

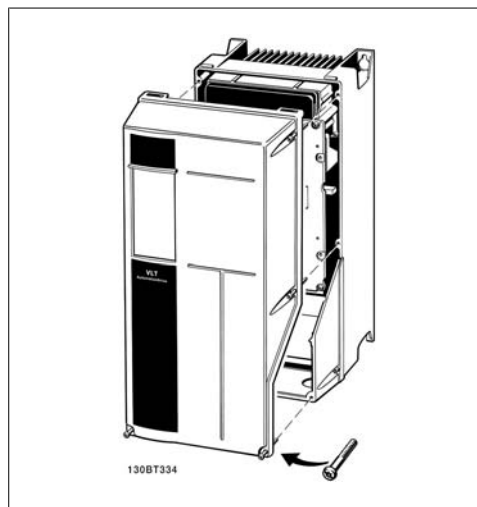

Illustration 6.10: A5, B1, B2, C1 and C2 enclosures

### 6.3.6. Control Terminals

#### Control Terminals, FC 301

##### Drawing reference numbers:

1. 8 pole plug digital I/O.
2. 3 pole plug RS485 Bus.
3. 6 pole analog I/O.
4. USB Connection.

#### Control Terminals, FC 302

##### Drawing reference numbers:

1. 10 pole plug digital I/O.
2. 3 pole plug RS485 Bus.
3. 6 pole analog I/O.
4. USB Connection.

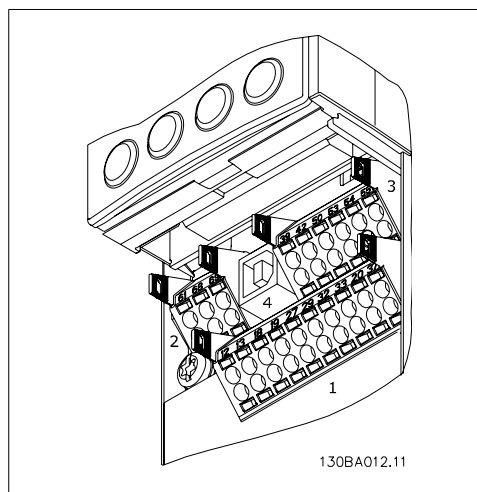

Illustration 6.11: Control terminals (all enclosures)

### 6.3.7. Electrical Installation, Control Terminals

#### To mount the cable to the terminal:

1. Strip isolation of 9-10 mm
2. Insert a screw driver<sup>1)</sup> in the square hole.
3. Insert the cable in the adjacent circular hole.
4. Remove the screw driver. The cable is now mounted to the terminal.

#### To remove the cable from the terminal:

1. Insert a screw driver<sup>1)</sup> in the square hole.
2. Pull out the cable.

<sup>1)</sup> Max. 0.4 x 2.5 mm

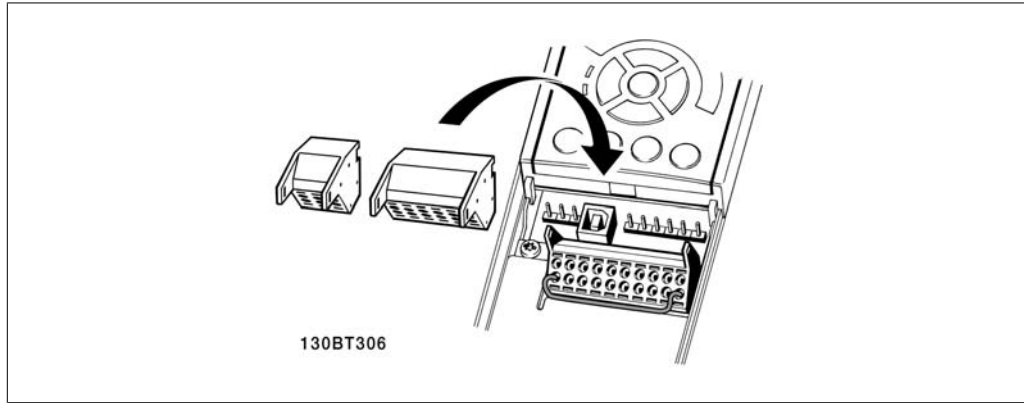
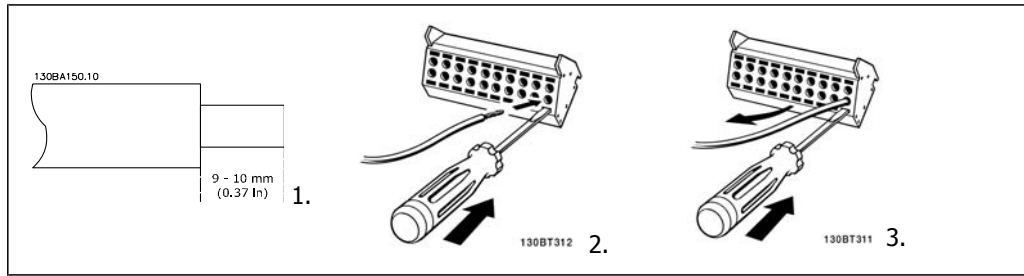

Assembling of IP55 / NEMA Type 12 (A5 housing) with mains disconnect

Mains switch is placed on left side on B1, B2, C1 and C2 enclosures. Mains switch on A5 enclosure is placed on right side

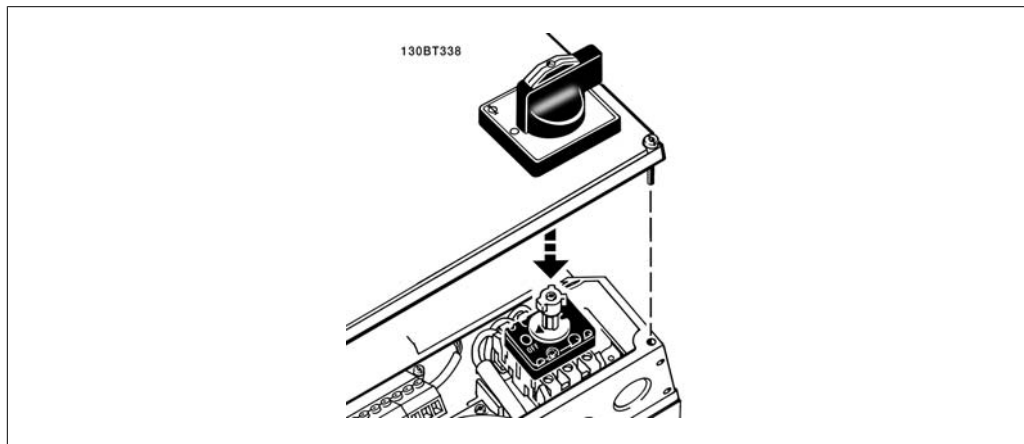

### 6.3.8. Basic Wiring Example

1. Mount terminals from the accessory bag to the front of the FC 300.
2. Connect terminals 18, 27 and 37 (FC 302 only) to +24 V (terminal 12/13)

Default settings:

18 = Start, Par 5-10 [9]

27 = Stop inverse, Par 5-12 [6]

37 = safe stop inverse

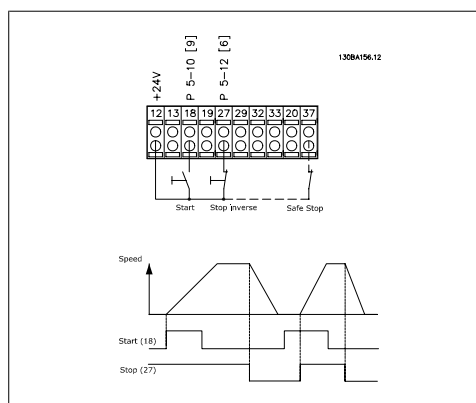

### 6.3.9. Electrical Installation, Control Cables

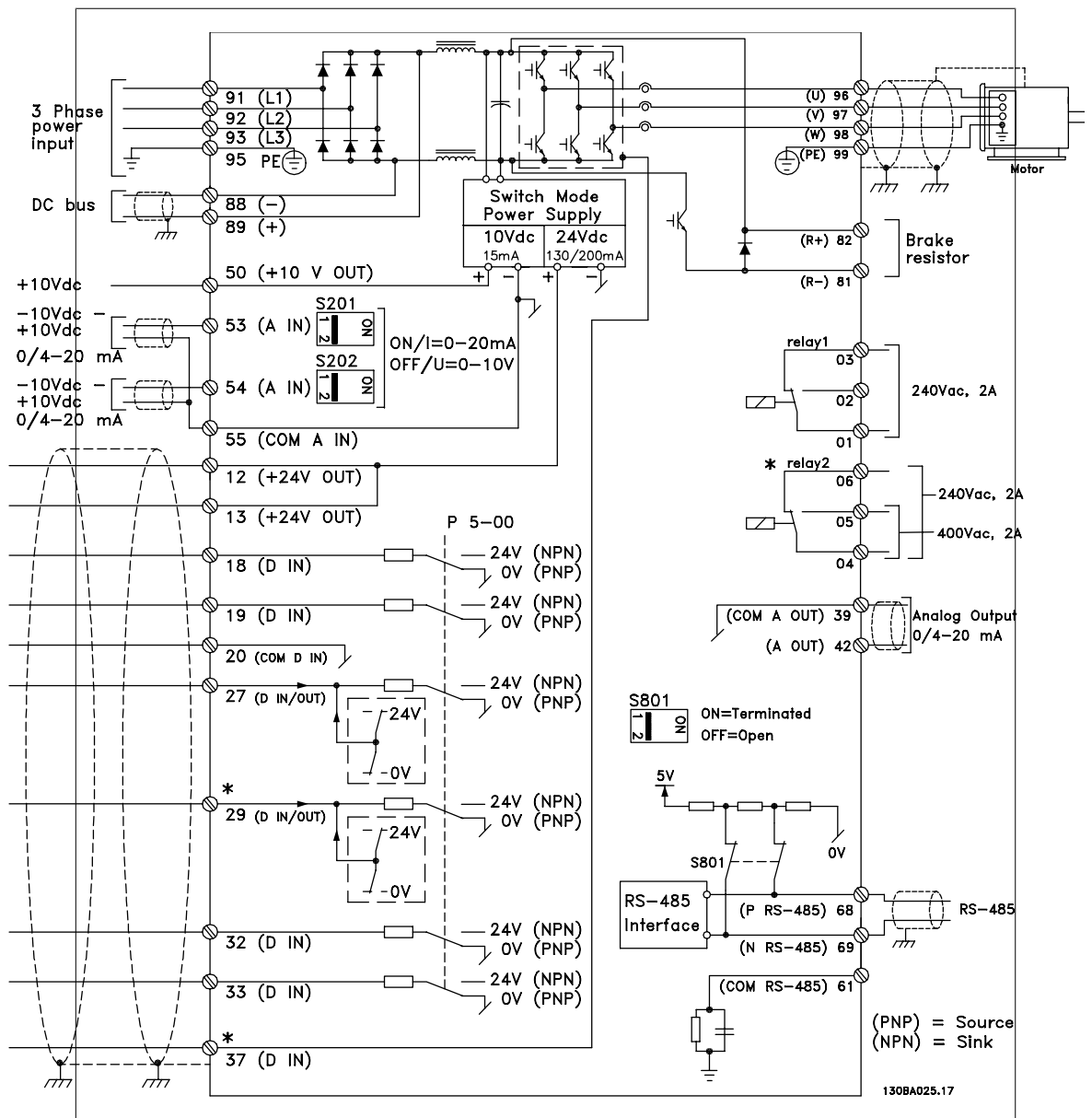

Illustration 6.12: Diagram showing all electrical terminals without options.

Terminal 37 is the input to be used for Safe Stop. For instructions on Safe Stop installation please refer to the section *Safe Stop Installation* in the FC 300 Design Guide.

\* Terminal 37 is not included in FC 301 (Except FC 301 A1, which includes Safe Stop).

Terminal 29 and Relay 2, are not included in FC 301.

Very long control cables and analogue signals may in rare cases and depending on installation result in 50/60 Hz earth loops due to noise from mains supply cables.

If this occurs, it may be necessary to break the screen or insert a 100 nF capacitor between screen and chassis.

The digital and analogue in- and outputs must be connected separately to the FC 300 common inputs (terminal 20, 55, 39) to avoid ground currents from both groups to affect other groups. For example, switching on the digital input may disturb the analog input signal.

### Input polarity of control terminals

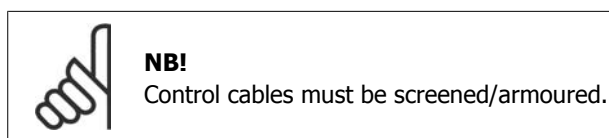
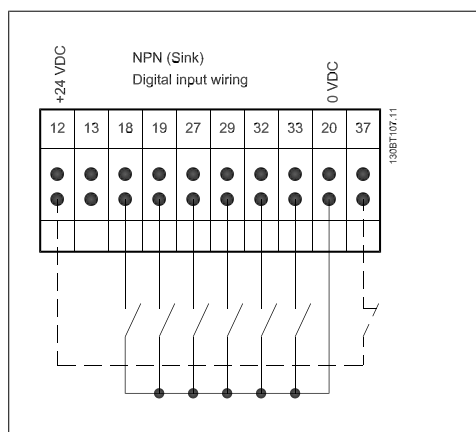
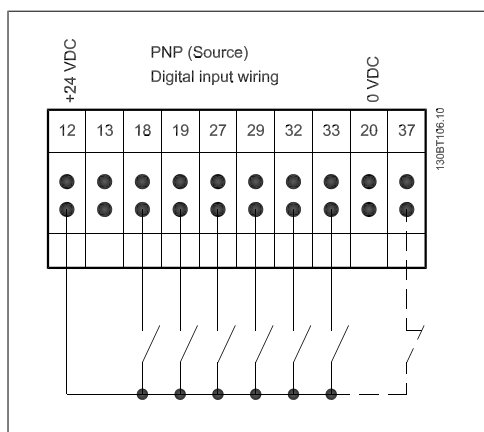

See section entitled *Earthing of Screened/Armoured Control Cables* for the correct termination of control cables.

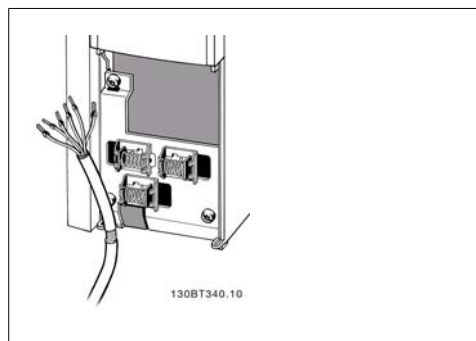

### 6.3.10. Motor Cables

See section *General Specifications* for correct dimensioning of motor cable cross-section and length.

- Use a screened/armoured motor cable to comply with EMC emission specifications.
- Keep the motor cable as short as possible to reduce the noise level and leakage currents.
- Connect the motor cable screen to both the decoupling plate of the FC 300 and to the metal cabinet of the motor.
- Make the screen connections with the largest possible surface area (cable clamp). This is done by using the supplied installation devices in the FC 300.
- Avoid mounting with twisted screen ends (pigtailed), which will spoil high frequency screening effects.
- If it is necessary to split the screen to install a motor isolator or motor relay, the screen must be continued with the lowest possible HF impedance.

### 6.3.11. Electrical Installation of Motor Cables

#### Screening of cables



Avoid installation with twisted screen ends (pigtailed). They spoil the screening effect at higher frequencies.

If it is necessary to break the screen to install a motor isolator or motor contactor, the screen must be continued at the lowest possible HF impedance.

#### Cable length and cross-section

The frequency converter has been tested with a given length of cable and a given cross-section of that cable. If the cross-section is increased, the cable capacitance - and thus the leakage current - may increase, and the cable length must be reduced correspondingly.

#### Switching frequency

When frequency converters are used together with Sine-wave filters to reduce the acoustic noise from a motor, the switching frequency must be set according to the Sine-wave filter instruction in *Par. 14-01*.

#### Aluminium conductors

Aluminium conductors are not recommended. Terminals can accept aluminium conductors but the conductor surface has to be clean and the oxidation must be removed and sealed by neutral acid free Vaseline grease before the conductor is connected.

Furthermore, the terminal screw must be retightened after two days due to the softness of the aluminium. It is crucial to keep the connection a gas tight joint, otherwise the aluminium surface will oxidize again.

### 6.3.12. Switches S201, S202, and S801

Switches S201 (A53) and S202 (A54) are used to select a current (0-20 mA) or a voltage (-10 to 10 V) configuration of the analog input terminals 53 and 54 respectively.

Switch S801 (BUS TER.) can be used to enable termination on the RS-485 port (terminals 68 and 69).

See drawing *Diagram showing all electrical terminals* in section *Electrical Installation*.

#### Default setting:

S201 (A53) = OFF (voltage input)

S202 (A54) = OFF (voltage input)

S801 (Bus termination) = OFF



When changing the function of S201, S202 or S801 be careful not to use force for the switch over. It is recommended to remove the LCP fixture (cradle) when operating the switches. The switches must not be operated with power on the frequency converter.

6

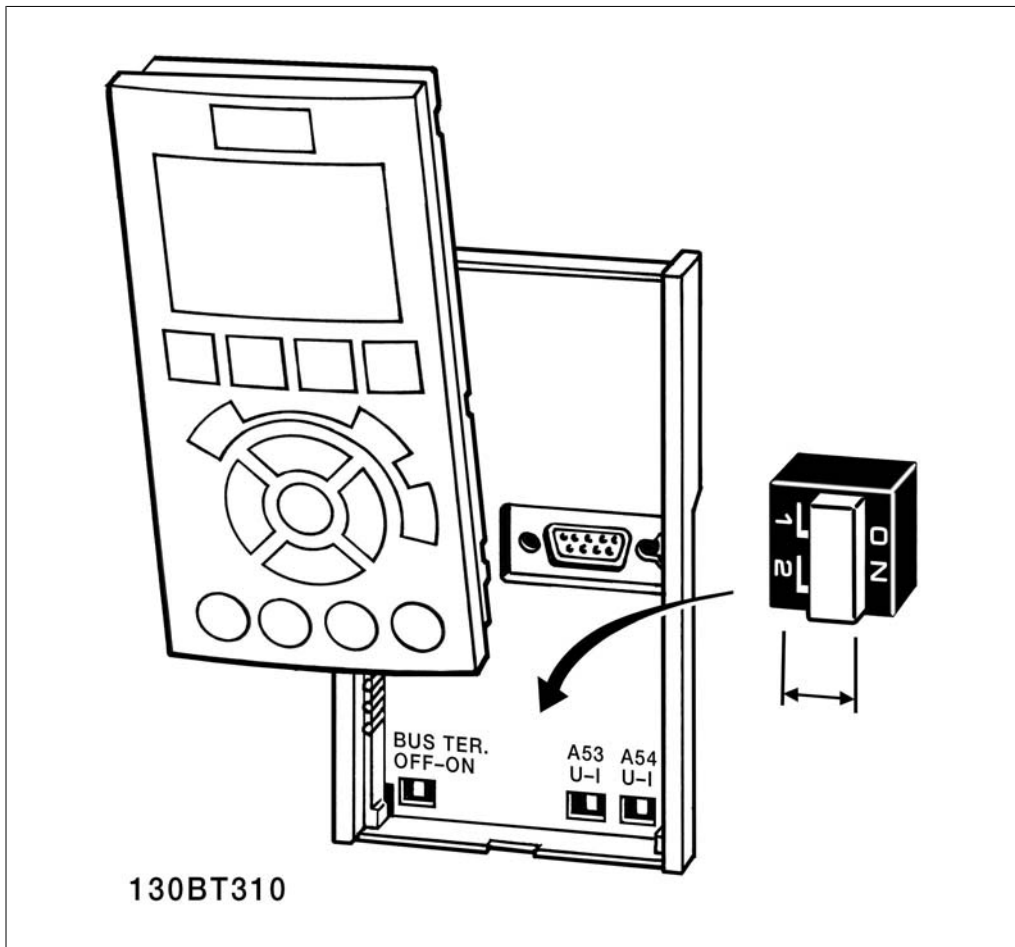

### 6.4.1. Final Set-Up and Test

To test the set-up and ensure that the frequency converter is running, follow these steps.

#### Step 1. Locate the motor name plate

**NB!**  
The motor is either star- (Y) or delta- connected ( $\Delta$ ). This information is located on the motor name plate data.

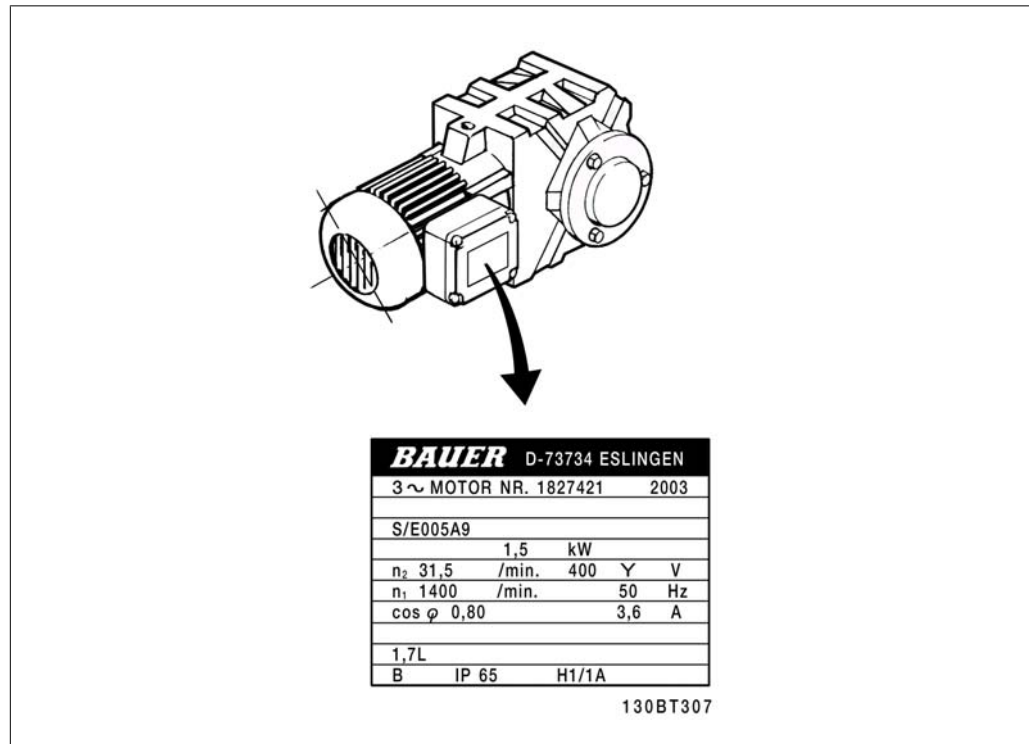

#### Step 2. Enter the motor name plate data in this parameter list.

To access this list first press the [QUICK MENU] key then select "Q2 Quick Setup".

1.	Motor Power [kW] or Motor Power [HP]	par. 1-20 par. 1-21
2.	Motor Voltage	par. 1-22
3.	Motor Frequency	par. 1-23
4.	Motor Current	par. 1-24
5.	Motor Nominal Speed	par. 1-25

#### Step 3. Activate the Automatic Motor Adaptation (AMA)

**Performing an AMA will ensure optimum performance. The AMA measures the values from the motor model equivalent diagram.**

1. Connect terminal 37 to terminal 12 (if terminal 37 is available).
2. Connect terminal 27 to terminal 12 or set par. 5-12 to 'No function' (par. 5-12 [0]).
3. Activate the AMA par. 1-29.
4. Choose between complete or reduced AMA. If a Sine-wave filter is mounted, run only the reduced AMA, or remove the Sine-wave filter during the AMA procedure.
5. Press the [OK] key. The display shows "Press [Hand on] to start".
6. Press the [Hand on] key. A progress bar indicates if the AMA is in progress.

### Stop the AMA during operation

1. Press the [OFF] key - the frequency converter enters into alarm mode and the display shows that the AMA was terminated by the user.

### Successful AMA

1. The display shows "Press [OK] to finish AMA".
2. Press the [OK] key to exit the AMA state.

### Unsuccessful AMA

1. The frequency converter enters into alarm mode. A description of the alarm can be found in the *Warnings and Alarms* chapter.
2. "Report Value" in the [Alarm Log] shows the last measuring sequence carried out by the AMA, before the frequency converter entered alarm mode. This number along with the description of the alarm will assist you in troubleshooting. If you contact Danfoss for service, make sure to mention number and alarm description.



#### NB!

Unsuccessful AMA is often caused by incorrectly registered motor name plate data or a too big difference between the motor power size and the frequency converter power size.

### Step 4. Set speed limit and ramp time

Minimum Reference	par. 3-02
Maximum Reference	par. 3-03

Table 6.1: Set up the desired limits for speed and ramp time.

Motor Speed Low Limit	par. 4-11 or 4-12
Motor Speed High Limit	par. 4-13 or 4-14

Ramp-up Time 1 [s]	par. 3-41
Ramp-down Time 1 [s]	par. 3-42

## 6.5. Additional Connections

### 6.5.1. DC bus connection

The DC bus terminal is used for DC back-up, with the intermediate circuit being supplied from an external source.

Terminal numbers: 88, 89

Please contact Danfoss if you require further information.

### 6.5.2. Installation of Load sharing

The connection cable must be screened and the max. length from the frequency converter to the DC bar is 25 metres.

**NB!**  
DC bus and load sharing calls for extra equipment and safety considerations. For further information, see Load sharing Instructions MI.50.NX.YY.

**NB!**  
Voltages up to 975 V DC (@ 600 V AC) may occur between the terminals.

### 6.5.3. Brake Connection Option

The connection cable to the brake resistor must be screened/armoured.

No	81	82	Brake resistor
	R-	R	terminals
		+	

**NB!**  
Dynamic brake calls for extra equipment and safety considerations. For further information, please contact Danfoss.

1. Use cable clamps to connect the screen to the metal cabinet of the frequency converter and to the decoupling plate of the brake resistor.
2. Dimension the cross-section of the brake cable to match the brake current.

**NB!**  
Voltages up to 975 V DC (@ 600 V AC) may occur between the terminals.

**NB!**  
If a short circuit in the brake IGBT occurs, prevent power dissipation in the brake resistor by using a mains switch or contactor to disconnect the mains for the frequency converter. Only the frequency converter shall control the contactor.

## 6.5.4. Relay Connection

To set relay output, see par. group 5-4\* Relays.

No	01 - 02	make (normally open)
	01 - 03	break (normally closed)
	04 - 05	make (normally open)
	04 - 06	break (normally closed)

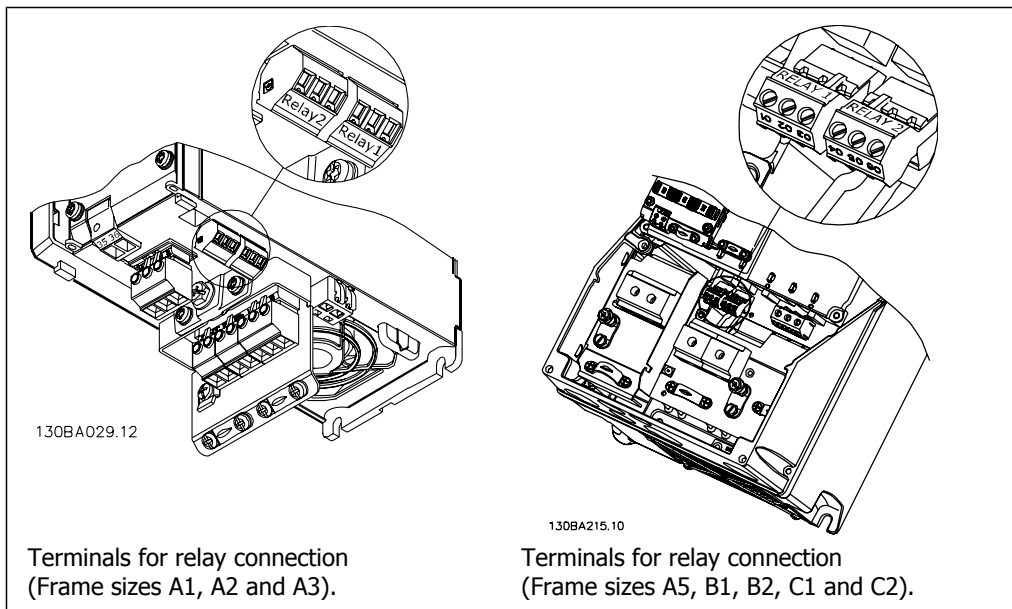

## 6.5.5. Relay Output

### Relay 1

- Terminal 01: common
- Terminal 02: normal open 240 V AC
- Terminal 03: normal closed 240 V AC

### Relay 2 (Not FC 301)

- Terminal 04: common
- Terminal 05: normal open 400 V AC
- Terminal 06: normal closed 240 V AC

Relay 1 and relay 2 are programmed in par. 5-40, 5-41, and 5-42.

Additional relay outputs by using option module MCB 105.

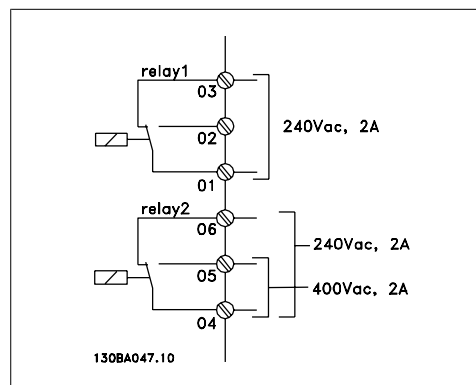

## 6.5.6. Parallel Connection of Motors

The frequency converter can control several parallel-connected motors. The total current consumption of the motors must not exceed the rated output current  $I_{INV}$  for the frequency converter.

This is only recommended when U/f is selected in par. 1-01.

**NB!**  
Installations with cables connected in a common joint as in illustration 1 is only recommended for short cable lengths.

**NB!**  
When motors are connected in parallel, par. 1-02 *Automatic Motor Adaptation (AMA)* cannot be used, and par. 1-01 *Motor Control Principle* must be set to *Special motor characteristics (U/f)*.

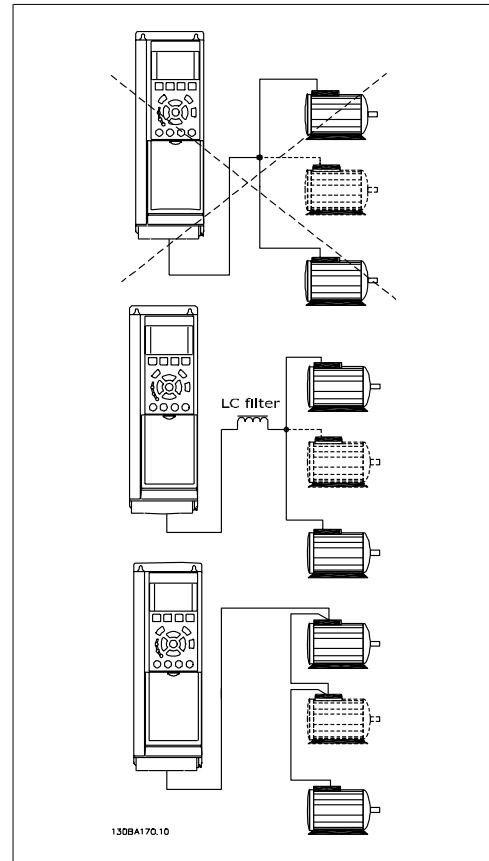

Problems may arise at start and at low RPM values if motor sizes are widely different because small motors' relatively high ohmic resistance in the stator calls for a higher voltage at start and at low RPM values.

The electronic thermal relay (ETR) of the frequency converter cannot be used as motor protection for the individual motor of systems with parallel-connected motors. Provide further motor protection by e.g. thermistors in each motor or individual thermal relays. (Circuit breakers are not suitable as protection).

### 6.5.7. Direction of Motor Rotation

The default setting is clockwise rotation with the frequency converter output connected as follows.

- Terminal 96 connected to U-phase
- Terminal 97 connected to V-phase
- Terminal 98 connected to W-phase

The direction of motor rotation is changed by switching two motor phases.

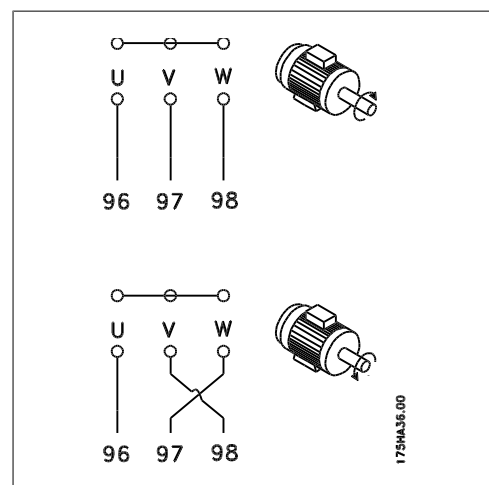

### 6.5.8. Motor Thermal Protection

The electronic thermal relay in the frequency converter has received the UL-approval for single motor protection, when par. 1-90 *Motor Thermal Protection* is set for *ETR Trip* and par. 1-24 *Motor current,  $I_{M,N}$*  is set to the rated motor current (see motor name plate). For thermal motor protection it is also possible to use the MCB 112 PTC Thermistor Card option. This card provides ATEX certificate to protect motors in explosion hazardous areas, Zone 1/21 and Zone 2/22. Please refer to the *Design Guide* for further information.

### 6.5.9. Motor Thermal Protection

The electronic thermal relay in the frequency converter has received the UL-approval for single motor protection, when par. 1-90 *Motor Thermal Protection* is set for *ETR Trip* and par. 1-24 *Motor current,  $I_{M,N}$*  is set to the rated motor current (see motor name plate). For thermal motor protection it is also possible to use the MCB 112 PTC Thermistor Card option. This card provides ATEX certificate to protect motors in explosion hazardous areas, Zone 1/21 and Zone 2/22. Please refer to the *Design Guide* for further information.

6

### 6.6.1. Installation of Brake Cable

(Only for frequency converters ordered with brake chopper option).

The connection cable to the brake resistor must be screened.

1. Connect the screen by means of cable clamps to the conductive back plate on the frequency converter and to the metal cabinet of the brake resistor.
2. Size the brake cable cross-section to match the brake torque.

No.	Function
81, 82	Brake resistor terminals

See Brake instructions, MI.90.FX.YY and MI.50.SX.YY for more information about safe installation.

**NB!** Voltages up to 960 V DC, depending on the supply voltage, may occur on the terminals.

### 6.6.2. RS 485 Bus Connection

One or more frequency converters can be connected to a control (or master) using the RS485 standardized interface. Terminal 68 is connected to the P signal (TX+, RX+), while terminal 69 is connected to the N signal (TX-,RX-).

If more than one frequency converter is connected to a master, use parallel connections.

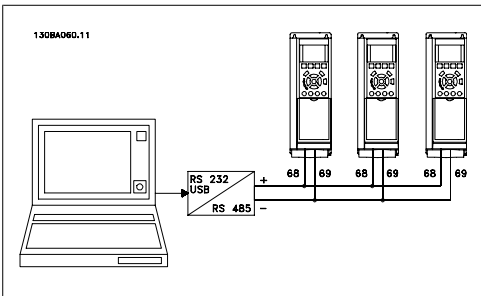

In order to avoid potential equalizing currents in the screen, earth the cable screen via terminal 61, which is connected to the frame via an RC-link.



**Bus termination**

The RS485 bus must be terminated by a resistor network at both ends. For this purpose, set switch S801 on the control card for "ON".

For more information, see the paragraph *Switches S201, S202, and S801*.



**NB!**  
Communication protocol must be set to FC MC par. 8-30.

**6.6.3. How to Connect a PC to the FC 300**

To control the frequency converter from a PC, install the MCT 10 Set-up Software.

The PC is connected via a standard (host/device) USB cable, or via the RS485 interface as shown in the section *Bus Connection* in the Programming Guide.

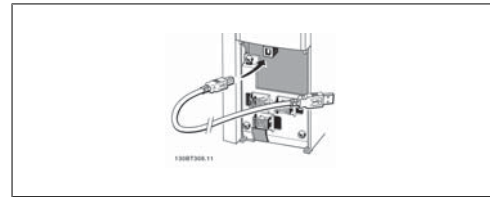



Illustration 6.13: USB connection.



**NB!**  
The USB connection is galvanically isolated from the supply voltage (PELV) and other high-voltage terminals. The USB connection is connected to protection earth on the frequency converter. Use only isolated laptop as PC connection to the USB connector on the FC 300 drive.

**6.6.4. The FC 300 PC Software**

**Data storage in PC via MCT 10 Set-Up Software:**

1. Connect a PC to the unit via USB com port
2. Open MCT 10 Set-up Software
3. Choose "Read from drive"
4. Choose "Save as"

All parameters are now stored.

**Data transfer from PC to drive via MCT 10 Set-Up Software:**

1. Connect a PC to the unit via USB com port
2. Open MCT 10 Set-up software
3. Choose "Open"– stored files will be shown
4. Open the appropriate file
5. Choose "Write to drive"

All parameters are now transferred to the drive.

A separate manual for MCT 10 Set-up Software is available.

**6.7.1. High Voltage Test**

Carry out a high voltage test by short-circuiting terminals U, V, W, L<sub>1</sub>, L<sub>2</sub> and L<sub>3</sub>. Energize by max. 2.15 kV DC for one second between this short-circuit and the chassis.

**NB!**

When running high voltage tests of the entire installation, interrupt the mains and motor connection if the leakage currents are too high.

### 6.7.2. Safety Earth Connection

The frequency converter has a high leakage current and must be earthed appropriately for safety reasons according to EN 50178.



The earth leakage current from the frequency converter exceeds 3.5 mA. To ensure a good mechanical connection from the earth cable to the earth connection (terminal 95), the cable cross-section must be at least 10 mm<sup>2</sup> or 2 rated earth wires terminated separately.

## 6

### 6.8.1. Electrical Installation -

The following is a guideline to good engineering practice when installing frequency converters. Follow these guidelines to comply with EN 61800-3 *First environment*. If the installation is in EN 61800-3 *Second environment*, i.e. industrial networks, or in an installation with its own transformer, deviation from these guidelines is allowed but not recommended. See also paragraphs *CE Labelling*, *General Aspects of EMC Emission* and *EMC Test Results*.

#### Good engineering practice to ensure EMC-correct electrical installation:

- Use only braided screened/armoured motor cables and braided screened/armoured control cables. The screen should provide a minimum coverage of 80%. The screen material must be metal, not limited to but typically copper, aluminium, steel or lead. There are no special requirements for the mains cable.
- Installations using rigid metal conduits are not required to use screened cable, but the motor cable must be installed in conduit separate from the control and mains cables. Full connection of the conduit from the drive to the motor is required. The EMC performance of flexible conduits varies a lot and information from the manufacturer must be obtained.
- Connect the screen/armour/conduit to earth at both ends for motor cables as well as for control cables. In some cases, it is not possible to connect the screen in both ends. If so, connect the screen at the frequency converter. See also *Earthing of Braided Screened/Armoured Control Cables*.
- Avoid terminating the screen/armour with twisted ends (pigtailed). It increases the high frequency impedance of the screen, which reduces its effectiveness at high frequencies. Use low impedance cable clamps or EMC cable glands instead.
- Avoid using unscreened/unarmoured motor or control cables inside cabinets housing the drive(s), whenever this can be avoided.

Leave the screen as close to the connectors as possible.

The illustration shows an example of an EMC-correct electrical installation of an IP 20 frequency converter. The frequency converter is fitted in an installation cabinet with an output contactor and connected to a PLC, which is installed in a separate cabinet. Other ways of doing the installation may have just as good an EMC performance, provided the above guide lines to engineering practice are followed.

If the installation is not carried out according to the guideline and if unscreened cables and control wires are used, some emission requirements are not complied with, although the immunity requirements are fulfilled. See the paragraph *EMC test results*.

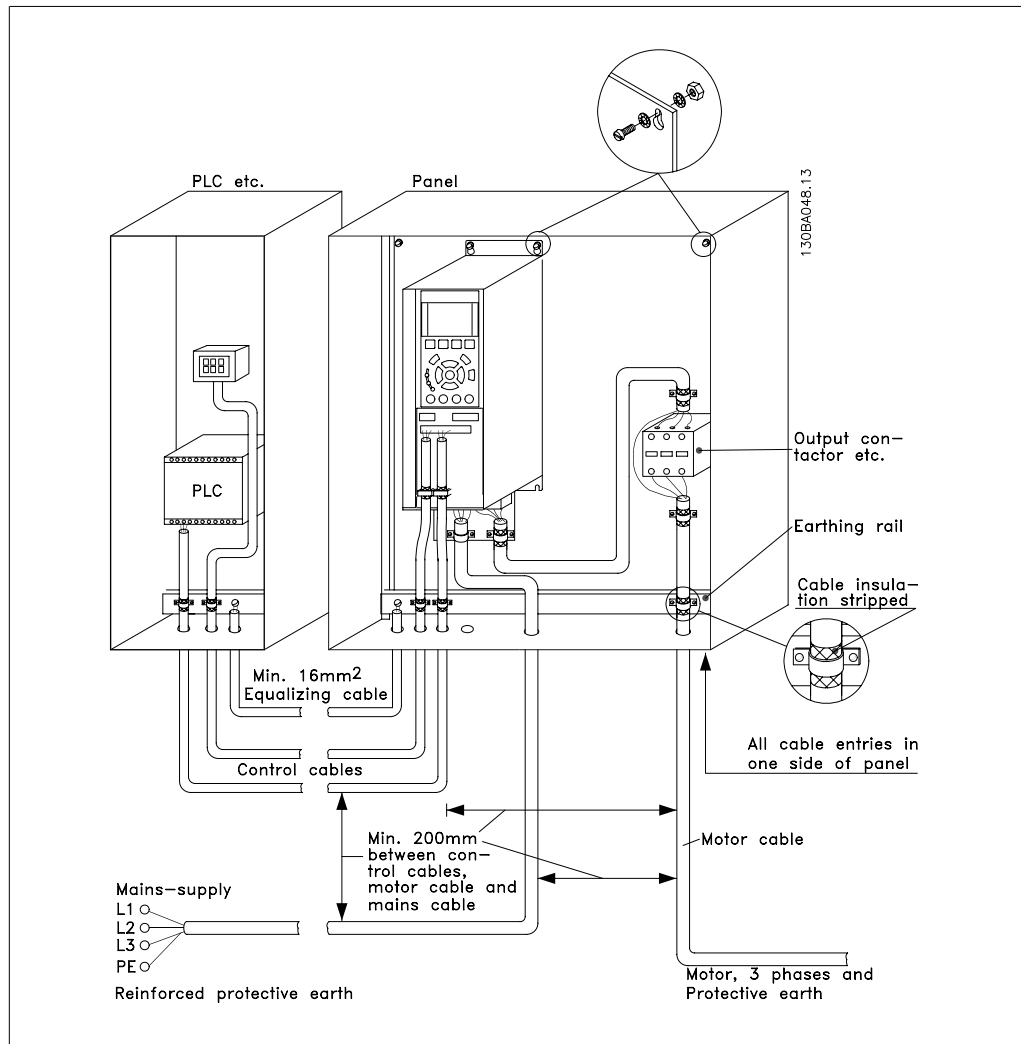

Illustration 6.14: EMC-correct electrical installation of a frequency converter in cabinet.

### 6.8.2. Use of EMC-Correct Cables

Danfoss recommends braided screened/armoured cables to optimise EMC immunity of the control cables and the EMC emission from the motor cables.

The ability of a cable to reduce the in- and outgoing radiation of electric noise depends on the transfer impedance ( $Z_T$ ). The screen of a cable is normally designed to reduce the transfer of electric noise; however, a screen with a lower transfer impedance ( $Z_T$ ) value is more effective than a screen with a higher transfer impedance ( $Z_T$ ).

Transfer impedance ( $Z_T$ ) is rarely stated by cable manufacturers but it is often possible to estimate transfer impedance ( $Z_T$ ) by assessing the physical design of the cable.

**Transfer impedance ( $Z_T$ ) can be assessed on the basis of the following factors:**

- The conductivity of the screen material.
- The contact resistance between the individual screen conductors.
- The screen coverage, i.e. the physical area of the cable covered by the screen - often stated as a percentage value.
- Screen type, i.e. braided or twisted pattern.

- a. Aluminium-clad with copper wire.1
- b. Twisted copper wire or armoured steel wire cable. 1
- c. Single-layer braided copper wire with varying percentage screen coverage. This is the typical Danfoss reference cable.1
- d. Double-layer braided copper wire.1
- e. Twin layer of braided copper wire with a magnetic, screened/armoured intermediate layer.1
- f. Cable that runs in copper tube or steel tube.1
- g. Lead cable with 1.1 mm wall thickness.1

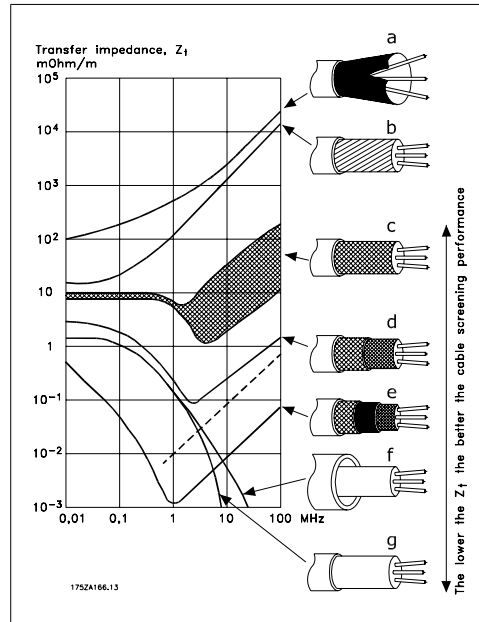

### 6.8.3. Earthing of Screened/Armoured Control Cables

Generally speaking, control cables must be braided screened/armoured and the screen must be connected by means of a cable clamp at both ends to the metal cabinet of the unit.

The drawing below indicates how correct earthing is carried out and what to do if in doubt.

- a. **Correct earthing**  
Control cables and cables for serial communication must be fitted with cable clamps at both ends to ensure the best possible electrical contact.<sup>1</sup>
- b. **Wrong earthing**  
Do not use twisted cable ends (pig-tails). They increase the screen impedance at high frequencies.<sup>1</sup>
- c. **Protection with respect to earth potential between PLC and VLT**  
If the earth potential between the frequency converter and the PLC (etc.) is different, electric noise may occur that will disturb the entire system. Solve this problem by fitting an equalising cable, next to the control cable. Minimum cable cross-section: 16 mm<sup>2</sup>.<sup>1</sup>
- d. **For 50/60 Hz earth loops**  
If very long control cables are used, 50/60 Hz earth loops may occur. Solve this problem by connecting one end of the screen to earth via a 100nF capacitor (keeping leads short).<sup>1</sup>
- e. **Cables for serial communication**  
Eliminate low-frequency noise currents between two frequency converters by connecting one end of the screen to terminal 61. This terminal is connected to earth via an internal RC link. Use twisted-pair cables to reduce the differential mode interference between the conductors.<sup>1</sup>

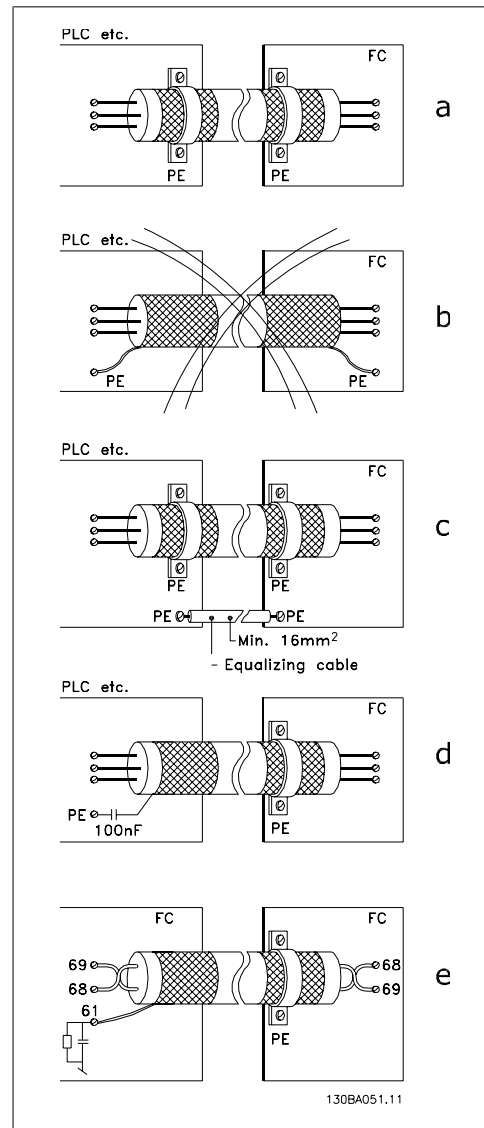

### 6.9.1. Mains Supply Interference/Harmonics

A frequency converter takes up a non-sinusoidal current from mains, which increases the input current  $I_{RMS}$ . A non-sinusoidal current is transformed by means of a Fourier analysis and split up into sine-wave currents with different frequencies, i.e. different harmonic currents  $I_N$  with 50 Hz as the basic frequency:

Harmonic currents	$I_1$	$I_5$	$I_7$
Hz	50 Hz	250 Hz	350 Hz

The harmonics do not affect the power consumption directly but increase the heat losses in the installation (transformer, cables). Consequently, in plants with a high percentage of rectifier load, maintain harmonic currents at a low level to avoid overload of the transformer and high temperature in the cables.

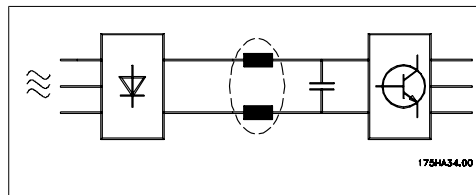
**NB!**

Some of the harmonic currents might disturb communication equipment connected to the same transformer or cause resonance in connection with power-factor correction batteries.

Harmonic currents compared to the RMS input current:

	Input current
$I_{RMS}$	1.0
$I_1$	0.9
$I_5$	0.4
$I_7$	0.2
$I_{11-49}$	< 0.1

To ensure low harmonic currents, the frequency converter is equipped with intermediate circuit coils as standard. This normally reduces the input current  $I_{RMS}$  by 40%.

The voltage distortion on the mains supply depends on the size of the harmonic currents multiplied by the mains impedance for the frequency in question. The total voltage distortion THD is calculated on the basis of the individual voltage harmonics using this formula:

$$THD\% = \sqrt{U \frac{2}{5} + U \frac{2}{7} + \dots + U \frac{2}{N}}$$

( $U_N\%$  of  $U$ )

### 6.10.1. Residual Current Device

You can use RCD relays, multiple protective earthing or earthing as extra protection, provided that local safety regulations are complied with.

If an earth fault appears, a DC content may develop in the faulty current.

If RCD relays are used, you must observe local regulations. Relays must be suitable for protection of 3-phase equipment with a bridge rectifier and for a brief discharge on power-up see section *Earth Leakage Current* for further information.

# 7. Application Examples

## 7.1.1. Start/Stop

- Terminal 18 = Par. 5-10 [8] *Start*
- Terminal 27 = Par. 5-12 [0] *No operation (Default coast inverse)*
- Terminal 37 = *Safe stop (where available!)*

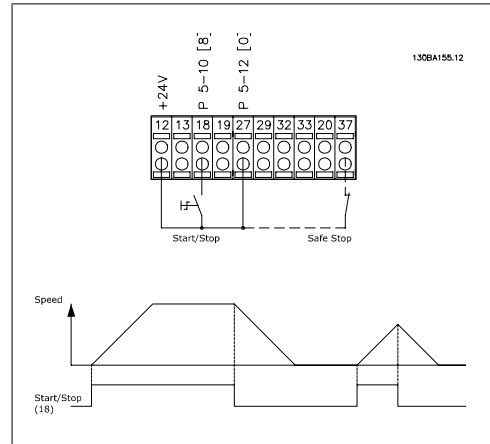

## 7.1.2. Pulse Start/Stop

- Terminal 18 = Par. 5-10 [9] *Latched start*
- Terminal 27 = Par. 5-12 [6] *Stop inverse*
- Terminal 37 = *Safe stop (where available!)*

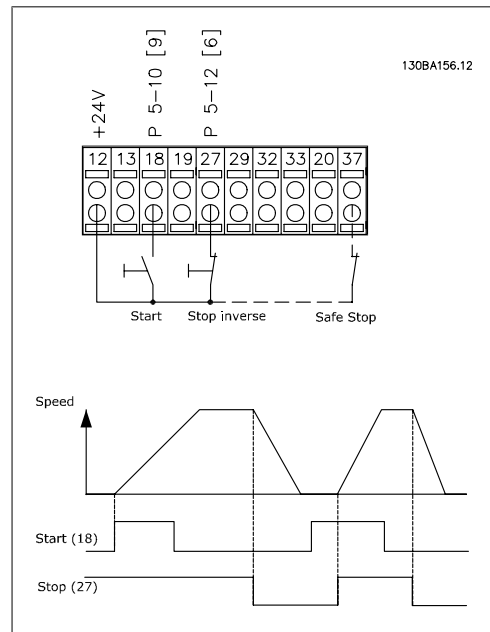

### 7.1.3. Potentiometer Reference

#### Voltage reference via a potentiometer:

Reference Source 1 = [1] *Analogue input 53* (default)

Terminal 53, Low Voltage = 0 Volt

Terminal 53, High Voltage = 10 Volt

Terminal 53, Low Ref./Feedback = 0 RPM

Terminal 53, High Ref./Feedback = 1500 RPM

Switch S201 = OFF (U)

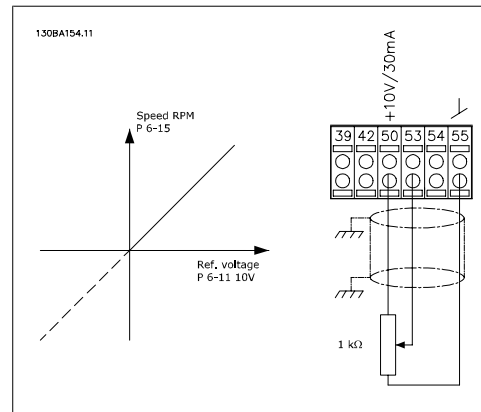



### 7.1.4. Encoder Connection

The purpose of this guideline is to ease the set-up of encoder connection to FC 300. Before setting up the encoder the basic settings for a closed loop speed control system will be shown.

#### Encoder Connection to FC 300

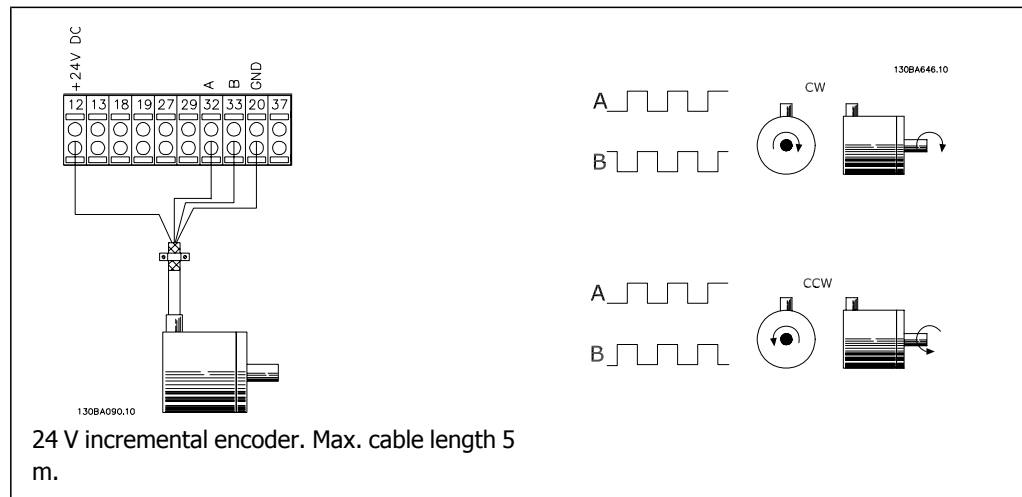

### 7.1.5. Encoder Direction

The direction of encoder is determined by which order the pulses are entering the drive. Clockwise direction means channel A is 90 electrical degrees before channel B. Counter Clockwise direction means channel B is 90 electrical degrees before A. The direction determined by looking into the shaft end.

### 7.1.6. Closed Loop Drive System

A drive system consist usually of more elements such as:

- Motor
- Add (Gearbox) (Mechanical Brake)
- FC 302 Automation Drive
- Encoder as feed-back system
- Brake resistor for dynamic braking
- Transmission
- Load

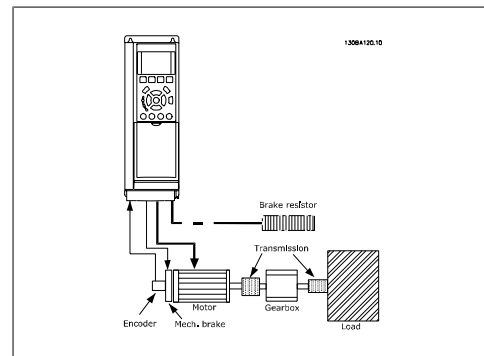

Illustration 7.1: **Basic Set-up for FC 302 Closed Loop Speed Control**

Applications demanding mechanical brake control will usually need a brake resistor.

### 7.1.7. Programming of Torque Limit and Stop

In applications with an external electro-mechanical brake, such as hoisting applications, it is possible to stop the frequency converter via a 'standard' stop command and simultaneously activate the external electro-mechanical brake.

The example given below illustrates the programming of frequency converter connections. The external brake can be connected to relay 1 or 2, see paragraph *Control of Mechanical Brake*. Program terminal 27 to Coast, inverse [2] or Coast and Reset, inverse [3], and program terminal 29 to Terminal mode 29 Output [1] and Torque limit & stop [27].

**Description:**

If a stop command is active via terminal 18 and the frequency converter is not at the torque limit, the motor ramps down to 0 Hz.

If the frequency converter is at the torque limit and a stop command is activated, terminal 29 Output (programmed to Torque limit and stop [27]) is activated. The signal to terminal 27 changes from 'logic 1' to 'logic 0', and the motor starts to coast, thereby ensuring that the hoist stops even if the frequency converter itself cannot handle the required torque (i.e. due to excessive overload).

- Start/stop via terminal 18  
Par. 5-10 Start [8]
- Quickstop via terminal 27  
Par. 5-12 Coasting Stop, Inverse [2]
- Terminal 29 Output  
Par. 5-02 Terminal 29 Mode Output [1]  
Par. 5-31 Torque Limit & Stop [27]
- Relay output [0] (Relay 1)  
Par. 5-40 Mechanical Brake Control [32]

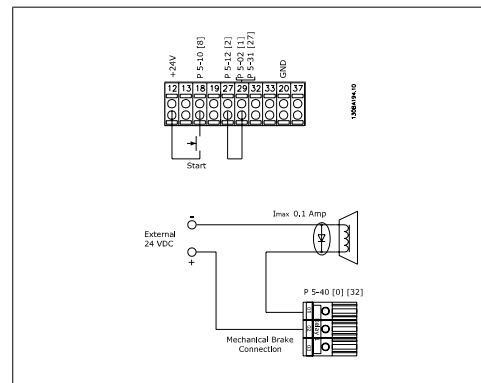

## 7.1.8. Automatic Motor Adaptation (AMA)

AMA is an algorithm to measure the electrical motor parameters on a motor at standstill. This means that AMA itself does not supply any torque.

AMA is useful when commissioning systems and optimising the adjustment of the frequency converter to the applied motor. This feature is particularly used where the default setting does not apply to the connected motor.

Par. 1-29 allows a choice of complete AMA with determination of all electrical motor parameters or reduced AMA with determination of the stator resistance  $R_s$  only.

The duration of a total AMA varies from a few minutes on small motors to more than 15 minutes on large motors.

**Limitations and preconditions:**

- For the AMA to determine the motor parameters optimally, enter the correct motor nameplate data in par. 1-20 to 1-26.
- For the best adjustment of the frequency converter, carry out AMA on a cold motor. Repeated AMA runs may lead to a heating of the motor, which results in an increase of the stator resistance,  $R_s$ . Normally, this is not critical.
- AMA can only be carried out if the rated motor current is minimum 35% of the rated output current of the frequency converter. AMA can be carried out on up to one oversize motor.
- It is possible to carry out a reduced AMA test with a Sine-wave filter installed. Avoid carrying out a complete AMA with a Sine-wave filter. If an overall setting is required, remove the Sine-wave filter while running a total AMA. After completion of the AMA, reinsert the Sine-wave filter.
- If motors are coupled in parallel, use only reduced AMA if any.

- Avoid running a complete AMA when using synchronous motors. If synchronous motors are applied, run a reduced AMA and manually set the extended motor data. The AMA function does not apply to permanent magnet motors.
- The frequency converter does not produce motor torque during an AMA. During an AMA, it is imperative that the application does not force the motor shaft to run, which is known to happen with e.g. wind milling in ventilation systems. This disturbs the AMA function.

### 7.1.9. Smart Logic Control Programming

A new useful facility in FC 300 is the Smart Logic Control (SLC).

In applications where a PLC is generating a simple sequence the SLC may take over elementary tasks from the main control.

SLC is designed to act from event sent to or generated in the FC 300. The frequency converter will then perform the pre-programmed action.

### 7.1.10. SLC Application Example

One sequence 1:

Start – ramp up – run at reference speed 2 sec – ramp down and hold shaft until stop.

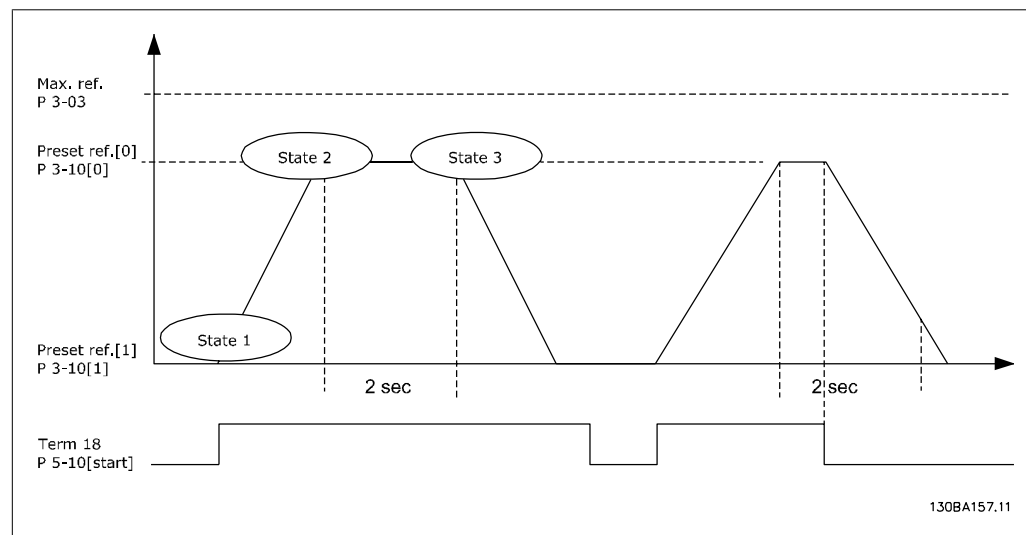

Set the ramping times in par. 3-41 and 3-42 to the wanted times

$$t_{ramp} = \frac{t_{acc} \times n_{norm} (par. 1 - 25)}{\Delta ref [RPM]}$$

Set term 27 to *No Operation* (par. 5-12)

Set Preset reference 0 to first preset speed (par. 3-10 [0]) in percentage of Max reference speed (par. 3-03). Ex.: 60%

Set preset reference 1 to second preset speed (par. 3-10 [1] Ex.: 0 % (zero).

Set the timer 0 for constant running speed in par. 13-20 [0]. Ex.: 2 sec.

Set Event 1 in par. 13-51 [1] to *True* [1]

Set Event 2 in par. 13-51 [2] to *On Reference* [4]

Set Event 3 in par. 13-51 [3] to *Time Out 0* [30]

Set Event 4 in par. 13-51 [1] to *False* [0]

Set Action 1 in par. 13-52 [1] to *Select preset 0* [10]

Set Action 2 in par. 13-52 [2] to *Start Timer 0* [29]

Set Action 3 in par. 13-52 [3] to *Select preset 1* [11]

Set Action 4 in par. 13-52 [4] to *No Action* [1]

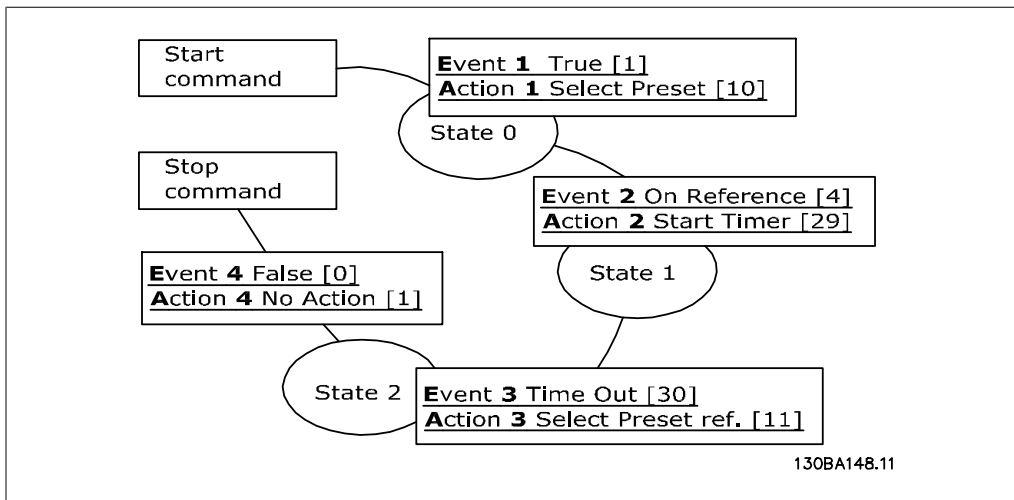

Set the Smart Logic Control in par. 13-00 to ON.

Start / stop command is applied on terminal 18. If stop signal is applied the frequency converter will ramp down and go into free mode.

## 8. Options and Accessories

### 8.1. Options and Accessories

Danfoss offers a wide range of options and accessories for VLT AutomationDrive FC 300 Series.

#### 8.1.1. Mounting of Option Modules in Slot A

Slot A position is dedicated to Fieldbus options. For further information, see separate operating instructions.

#### 8.1.2. Mounting of Option Modules in Slot B

The power to the frequency converter must be disconnected.

It is strongly recommended to make sure the parameter data is saved (i.e. by MCT10 software ) before option modules are inserted/removed from the drive.

- Remove the LCP (Local Control Panel), the terminal cover, and the LCP frame from the frequency converter.
- Fit the MCB10x option card into slot B.
- Connect the control cables and relieve the cable by the enclosed cable strips.  
\* Remove the knock out in the extended LCP frame, so that the option will fit under the extended LCP frame.
- Fit the extended LCP frame and terminal cover.
- Fit the LCP or blind cover in the extended LCP frame.
- Connect power to the frequency converter.
- Set up the input/output functions in the corresponding parameters, as mentioned in the section *General Technical Data*.

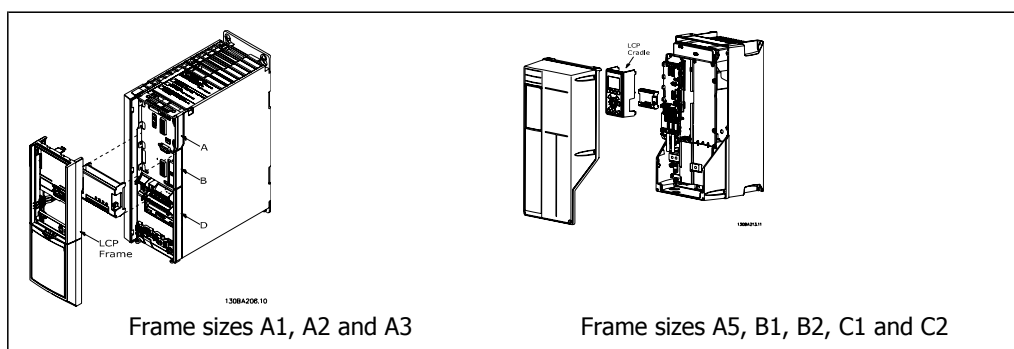

#### 8.1.3. General Purpose Input Output Module MCB 101

MCB 101 is used for extension of digital and analog inputs and outputs of FC 301 and FC 302 AutomationDrive.

Contents: MCB 101 must be fitted into slot B in the AutomationDrive.

- MCB 101 option module
- Extended fixture for LCP

- Terminal cover

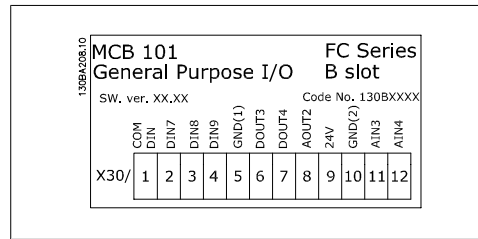

### 8.1.4. Galvanic Isolation In The MCB 101

Digital/analog inputs are galvanically isolated from other inputs/outputs on the MCB 101 and in the control card of the drive. Digital/analog outputs in the MCB 101 are galvanically isolated from other inputs/outputs on the MCB 101, but not from these on the control card of the drive.

If the digital inputs 7, 8 or 9 are to be switched by use of the internal 24 V power supply (terminal 9) the connection between terminal 1 and 5 which is illustrated in the drawing has to be established.

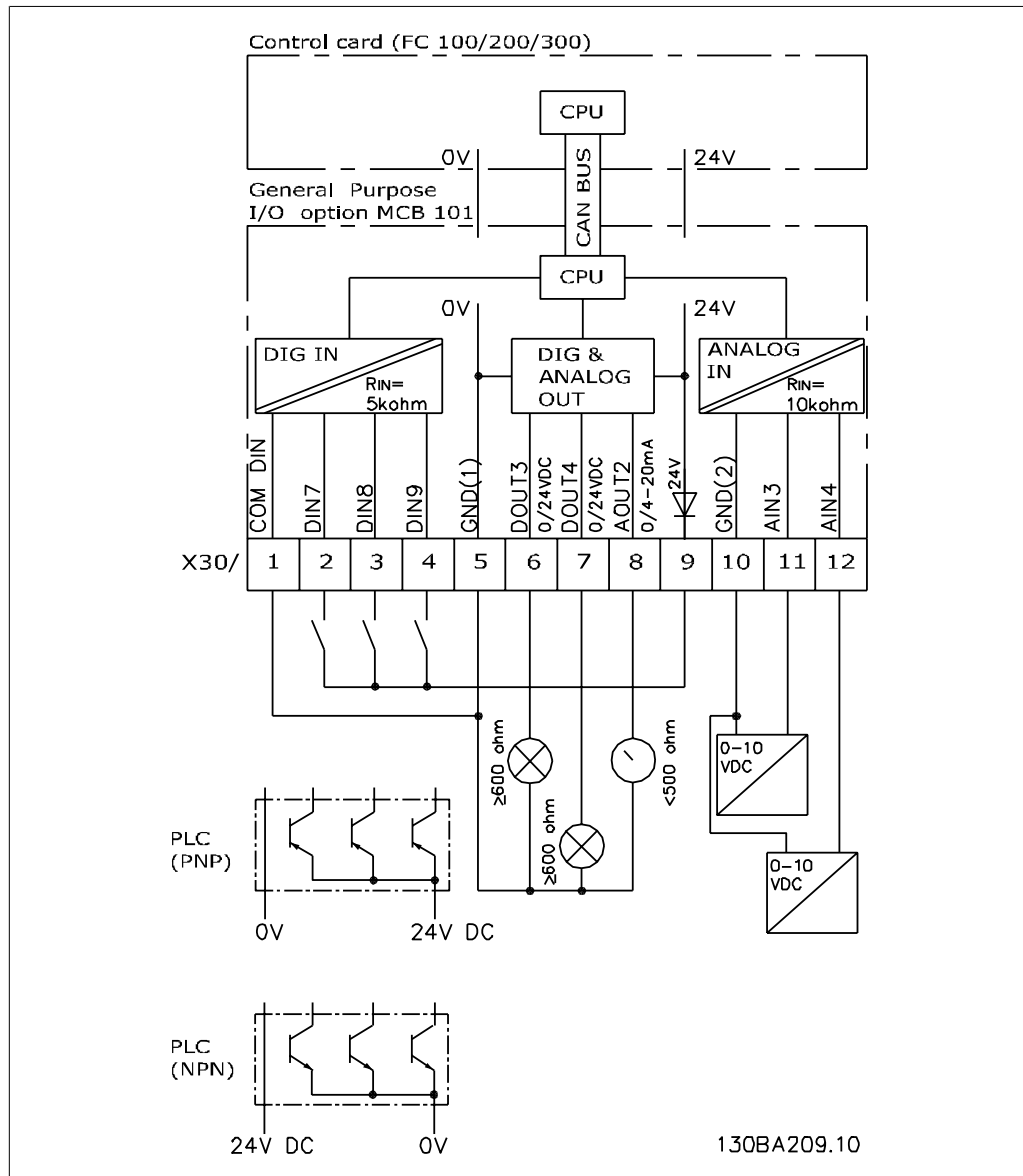

Illustration 8.1: Principle Diagram

### 8.1.5. Digital inputs - Terminal X30/1-4

Digital input:

Number of digital inputs	3
Terminal number	X30.2, X30.3, X30.4
Logic	PNP or NPN
Voltage level	0 - 24 V DC
Voltage level, logic '0' PNP (GND = 0 V)	< 5 V DC
Voltage level, logic '1' PNP (GND = 0 V)	> 10 V DC
Voltage level, logic '0' NPN (GND = 24V)	< 14 V DC
Voltage level, logic '1' NPN (GND = 24 V)	> 19 V DC
Maximum voltage on input	28 V continuous
Pulse frequency range	0 - 110 kHz
Duty cycle, min. pulse width	4.5 ms
Input impedance	> 2 k $\Omega$

### 8.1.6. Analog inputs - Terminal X30/11, 12:

Analog input:	
Number of analog inputs	2
Terminal number	X30.11, X30.12
Modes	Voltage
Voltage level	0 - 10 V
Input impedance	> 10 k $\Omega$
Max. voltage	20 V
Resolution for analog inputs	10 bit (+ sign)
Accuracy of analog inputs	Max. error 0.5% of full scale
Bandwidth	FC 301: 20 Hz/ FC 302: 100 Hz

### 8.1.7. Digital outputs - Terminal X30/6, 7:

Digital output:	
Number of digital outputs	2
Terminal number	X30.6, X30.7
Voltage level at digital/frequency output	0 - 24 V
Max. output current	40 mA
Max. load	$\geq$ 600 $\Omega$
Max. capacitive load	< 10 nF
Minimum output frequency	0 Hz
Maximum output frequency	$\leq$ 32 kHz
Accuracy of frequency output	Max. error: 0.1 % of full scale

### 8.1.8. Analog output - Terminal X30/8:

Analog output:	
Number of analog outputs	1
Terminal number	X30.8
Current range at analog output	0 - 20 mA
Max. load GND - analog output	500 $\Omega$
Accuracy on analog output	Max. error: 0.5 % of full scale
Resolution on analog output	12 bit

### 8.1.9. Encoder Option MCB 102

The encoder module can be used as feedback source for closed loop Flux control (par. 1-02) as well as closed loop speed control (par. 7-00). Configure encoder option in parameter group 17-xx

**Used for:**

- VVC<sup>plus</sup> closed loop
- Flux Vector Speed control
- Flux Vector Torque control
- Permanent magnet motor

**Supported encoder types:**

Incremental encoder: 5 V TTL type, RS422, max. frequency: 410 kHz

Incremental encoder: 1Vpp, sine-cosine

Hiperface® Encoder: Absolute and Sine-Cosine (Stegmann/SICK)

EnDat encoder: Absolute and Sine-Cosine (Heidenhain) Supports version 2.1

SSI encoder: Absolute

Encoder monitor:



The 4 encoder channels (A, B, Z, and D) are monitored, open and short circuit can be detected. There is a green LED for each channel which lights up when the channel is OK.

**NB!**  
The LEDs are only visible when removing the LCP. Reaction in case of an encoder error can be selected in par. 17-61: None, Warning or Trip.

**When the encoder option kit is ordered separately the kit includes:**

- Encoder module MCB 102
- Enlarged LCP fixture and enlarged terminal cover

The encoder option does not support FC 302 frequency converters manufactured before week 50/2004.

Min. software version: 2.03 (par. 15-43)

Con- nector Desig- nation X31	Incre- mental Encoder (please refer to Graphic A)	SinCos En- coder Hiper- face® (please re- fer to Graphic B)	EnDat En- coder	SSI Encod- er	Description
1	NC			24 V	24 V Output (21-25 V, I <sub>max</sub> :125 mA)
2	NC	8 Vcc			8 V Output (7-12 V, I <sub>max</sub> : 200 mA)
3	5 VCC		5 Vcc	5 V	5 V Output (5 V ± 5%, I <sub>max</sub> : 200 mA)
4	GND		GND	GND	GND
5	A input	+COS	+COS	A input	A input
6	A inv in- put	REFCOS	REFCOS	A input inv.	A inv input
7	B input	+SIN	+SIN	B input	B input
8	B inv in- put	REFSIN	REFSIN	B input inv.	B inv input
9	Z input	+Data RS485	Clock out	Clock out	Z input OR +Data RS485
10	Z inv in- put	-Data RS485	Clock out inv.	Clock out inv.	Z input OR -Data RS485
11	NC	NC	Data in	Data in	Future use
12	NC	NC	Data in inv.	Data in inv.	Future use

Max. 5V on  
X31.5-12

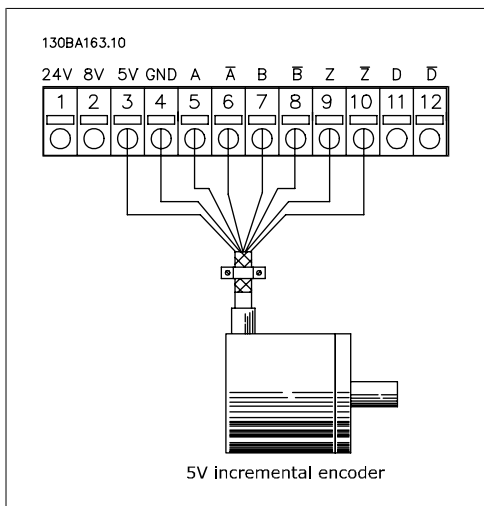

Max. cable length 150 m.

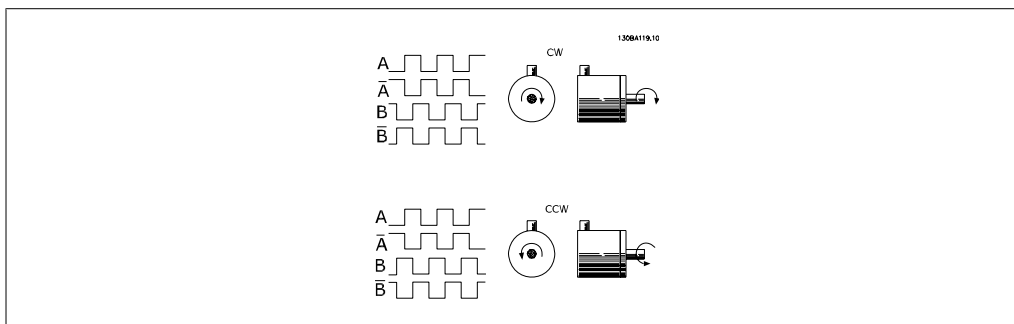
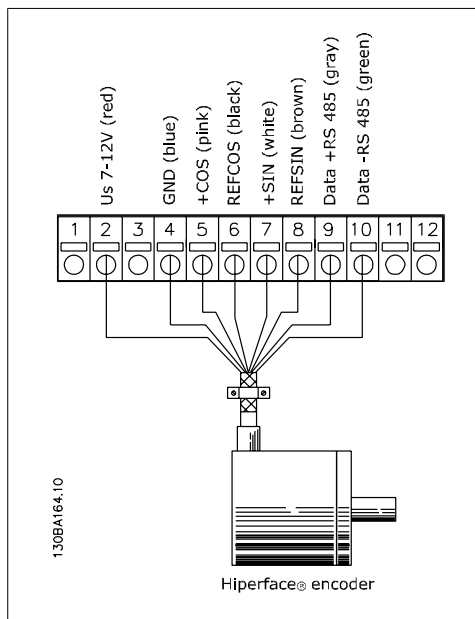

### 8.1.10. Resolver Option MCB 103

MCB 103 Resolver option is used for interfacing resolver motor feedback to FC 300 AutomationDrive. Resolvers are used basically as motor feedback device for Permanent Magnet brushless synchronous motors.

**When the Resolver option is ordered separately the kit includes:**

- Resolver option MCB 103
- Enlarged LCP fixture and enlarged terminal cover

Selection of parameters: 17-5x resolver Interface.

MCB 103 Resolver Option supports a various number of resolver types.

Resolver specifications:		
Resolver Poles	Par 17-50:	2 *2
Resolver Voltage	Input Par 17-51:	2.0 – 8.0 Vrms *7.0Vrms
Resolver Frequency	Input Par 17-52:	2 – 15 kHz *10.0 kHz
Transformation ratio	Par 17-53:	0.1 – 1.1 *0.5
Secondary input voltage	Max	4 Vrms
Secondary load	App.	10 kΩ

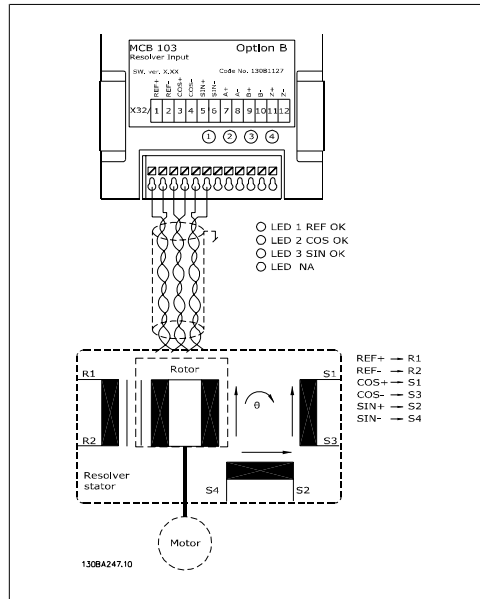

**NB!**  
 The resolver option MCB 103 can only be used with rotor-supplied resolver types. Stator-supplied resolvers cannot be used.

**LED indicators**

- LED 1 is on when the reference signal is OK to resolver
- LED 2 is on when Cosinus signal is OK from resolver
- LED 3 is on when Sinus signal is OK from resolver

The LEDs are active when par. 17-61 is set to *Warning* or *Trip*.

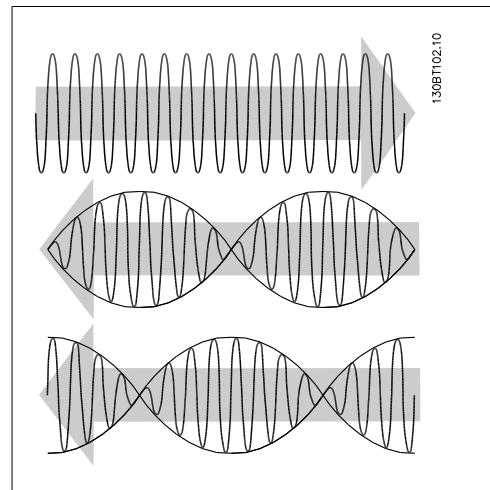

**Set-up example**

In this example a Permanent Magnet (PM) Motor is used with resolver as speed feedback. A PM motor must usually operate in flux mode.

**Wiring:**

The max cable length is 150 m when a twisted pair type of cable is used.

**NB!**  
 Resolver cables must be screened and separated from the motor cables.

**NB!**

The screen of the resolver cable must be correctly connected to the de-coupling plate and connected to chassis (earth) on the motor side.

**NB!**

Always use screened motor cables and brake chopper cables.

Adjust following parameters:

Par. 1-00	Configuration Mode	Speed closed loop [1]
Par. 1-01	Motor Control Principle	Flux with feedback [3]
Par. 1-10	Motor Construction	PM, non salient SPM [1]
Par. 1-24	Motor Current	Nameplate
Par. 1-25	Motor Nominal Speed	Nameplate
Par. 1-26	Motor Cont. Rated Torque	Nameplate
AMA is not possible on PM motors		
Par. 1-30	Stator Resistance	Motor data sheet
Par. 1-37	d-axis Inductance (Ld)	Motor data sheet (mH)
Par. 1-39	Motor Poles	Motor data sheet
Par. 1-40	Back EMF at 1000 RPM	Motor data sheet
Par. 1-41	Motor Angle Offset	Motor data sheet (Usually zero)
Par. 17-50	Poles	Resolver data sheet
Par. 17-51	Input Voltage	Resolver data sheet
Par. 17-52	Input Frequency	Resolver data sheet
Par. 17-53	Transformation Ratio	Resolver data sheet
Par. 17-59	Resolver Interface	Enabled [1]

### 8.1.11. Relay Option MCB 105

The MCB 105 option includes 3 pieces of SPDT contacts and must be fitted into option slot B.

Electrical Data:

Max terminal load (AC-1) <sup>1)</sup> (Resistive load)	240 V AC 2A
Max terminal load (AC-15) <sup>1)</sup> (Inductive load @ cosφ 0.4)	240 V AC 0.2 A
Max terminal load (DC-1) <sup>1)</sup> (Resistive load)	24 V DC 1 A
Max terminal load (DC-13) <sup>1)</sup> (Inductive load)	24 V DC 0.1 A
Min terminal load (DC)	5 V 10 mA
Max switching rate at rated load/min load	6 min <sup>-1</sup> /20 sec <sup>-1</sup>

1) IEC 947 part 4 and 5

**When the relay option kit is ordered separately the kit includes:**

- Relay Module MCB 105
- Enlarged LCP fixture and enlarged terminal cover
- Label for covering access to switches S201, S202 and S801
- Cable strips for fastening cables to relay module

The relay option does not support FC 302 frequency converters manufactured before week 50/2004.

Min. software version: 2.03 (par. 15-43).

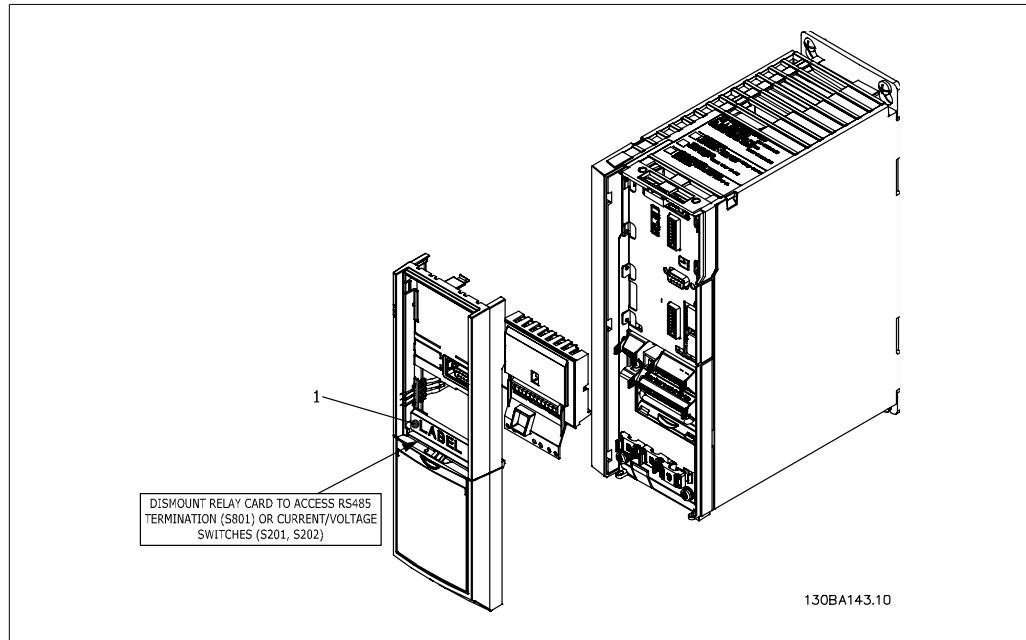

Illustration 8.2: Frame sizes A1, A2 and A3

**IMPORTANT**

1. The label **MUST** be placed on the LCP frame as shown (UL approved).

8

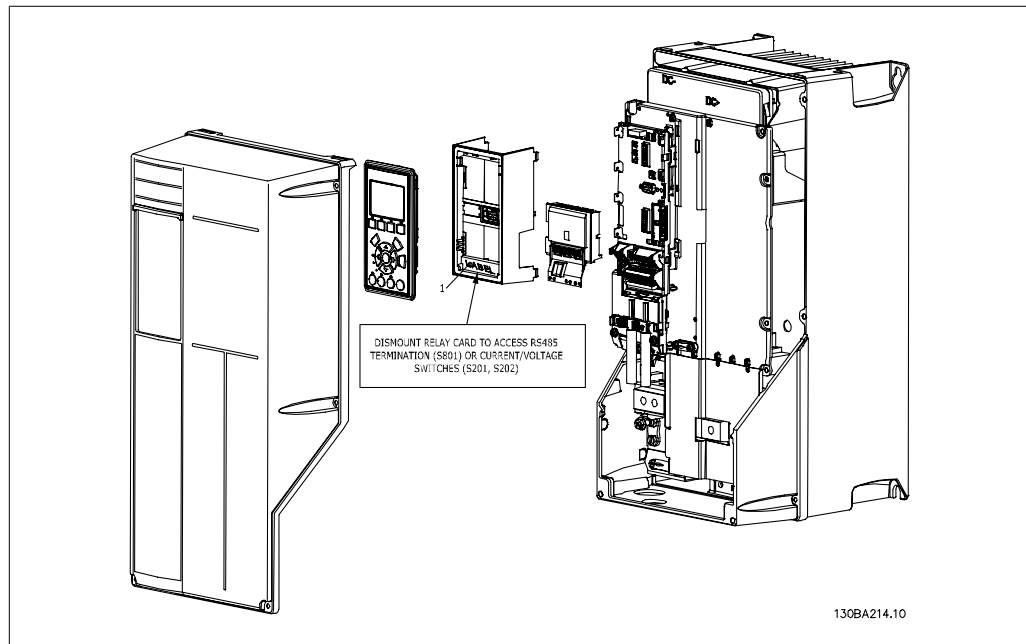



Illustration 8.3: Frame sizes A5, B1, B2, C1 and C2

**IMPORTANT**

1. The label **MUST** be placed on the LCP frame as shown (UL approved).



Warning Dual supply

How to add the MCB 105 option:

- The power to the frequency converter must be disconnected.

- The power to the live part connections on relay terminals must be disconnected.
- Remove the LCP, the terminal cover and the LCP fixture from the FC 30x.
- Fit the MCB 105 option in slot B.
- Connect the control cables and fasten the cables with the enclosed cable strips.
- Make sure the length of the stripped wire is correct (see the following drawing).
- Do not mix live parts (high voltage) with control signals (PELV).
- Fit the enlarged LCP fixture and enlarged terminal cover.
- Replace the LCP.
- Connect power to the frequency converter.
- Select the relay functions in par. 5-40 [6-8], 5-41 [6-8] and 5-42 [6-8].

NB (Array [6] is relay 7, array [7] is relay 8, and array [8] is relay 9)

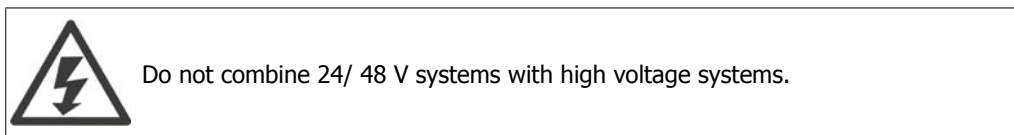
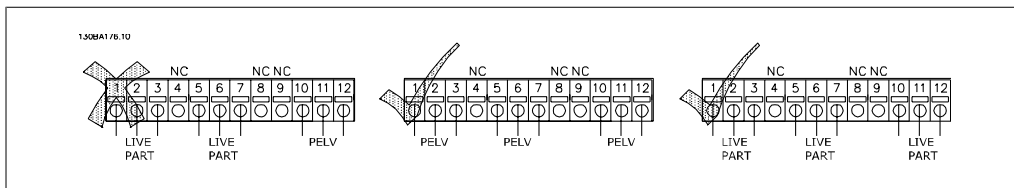
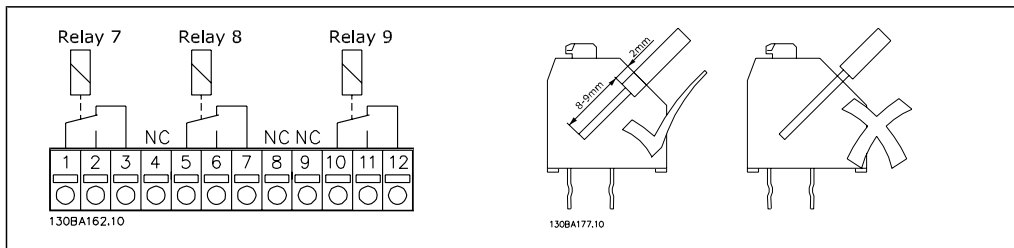

### 8.1.12. 24 V Back-Up Option MCB 107 (Option D)

#### External 24 V DC Supply

An external 24 V DC supply can be installed for low-voltage supply to the control card and any option card installed. This enables full operation of the LCP (including the parameter setting) without connection to mains.

#### External 24 V DC supply specification:

Input voltage range	24 V DC $\pm 15\%$ (max. 37 V in 10 s)
Max. input current	2.2 A
Average input current for FC 302	0.9 A
Max cable length	75 m
Input capacitance load	< 10 $\mu\text{F}$
Power-up delay	< 0.6 s
The inputs are protected.	

**Terminal numbers:**

Terminal 35: - external 24 V DC supply.

Terminal 36: + external 24 V DC supply.

**Follow these steps:**

1. Remove the LCP or Blind Cover
2. Remove the Terminal Cover
3. Remove the Cable Decoupling Plate and the plastic cover underneath
4. Insert the 24 V DC Back-up External Supply Option in the Option Slot
5. Mount the Cable Decoupling Plate
6. Attach the Terminal Cover and the LCP or Blind Cover.

When MCB 107, 24 V back-up option is supplying the control circuit, the internal 24 V supply is automatically disconnected.

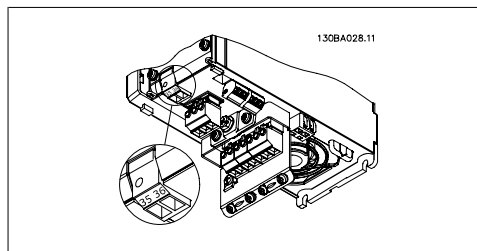

Illustration 8.4: Connection to 24 V back-up supply on frame sizes A2 and A3.

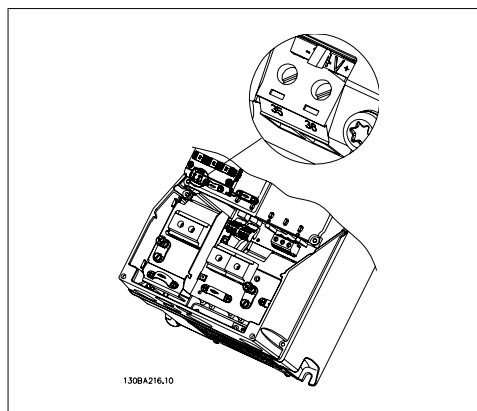

Illustration 8.5: Connection to 24 V back-up supply on frame sizes A5, B1, B2, C1 and C2.

### 8.1.13. MCB 112 VLT® PTC Thermistor Card

The MCB 112 option makes it possible to monitor the temperature of an electrical motor through a PTC thermistor input. It is a B-option for VLT® AutomationDrive FC 302 with Safe Stop.

For information on mounting and installation of the option, please see *Mounting of Option Modules in Slot B* earlier in this section

X44/ 1 and X44/ 2 are the thermistor inputs, X44/ 12 will enable Safe Stop of the FC 302 (T-37) if the thermistor values make it necessary and X44/ 10 will inform the FC 302 that the request for Safe Stop came from the MCB 112 in order to ensure a suitable alarm handling.

X44/ 1 and X44/ 2 are the thermistor inputs, X44/ 12 will enable safe stop of the FC 302 (T-37) if the thermistor values make it necessary and X44/ 10 will inform the FC 302 that a request for Safe Stop came from the MCB 112 in order to ensure a suitable alarm handling. One of the Digital Inputs of the FC302 (or a DI of a mounted option) must be set to PCT Card 1 [80] in order to use the information from X44/ 10. Par. 5-19 Terminal 37 Safe Stop must be configured to the desired Safe Stop functionality (default is Safe Stop Alarm).

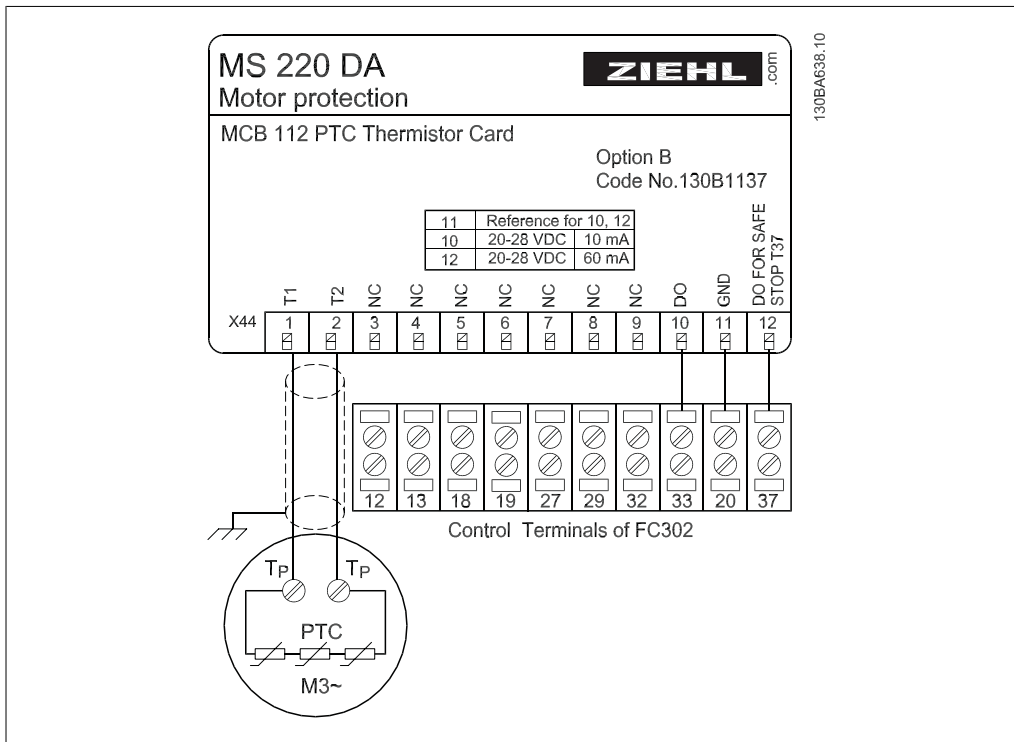

**ATEX Certification with VLT® AutomationDrive FC 302**

The MCB 112 has been certified for ATEX which means that the VLT® AutomationDrive FC 302 together with the MCB 112 can now be used with motors in potentially explosive atmospheres. See the Operating Instructions for the MCB 112 for more information.

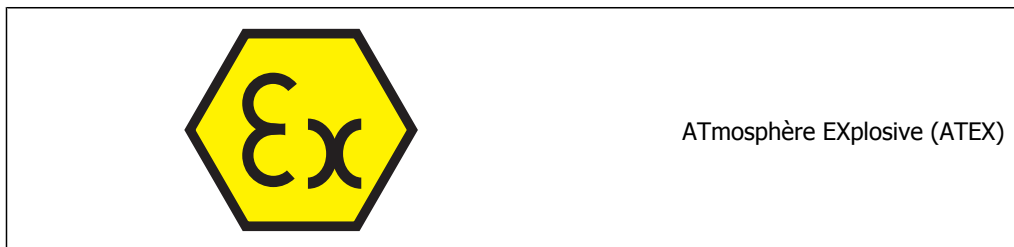

**Electrical Data**

Resistor connection:

PTC compliant with DIN 44081 and DIN 44082

Number	1..6 resistors in series
Shut-off value	3.3 kW .... 3.65 kW ... 3.85 kW
Reset value	1.7 kW .... 1.8 kW ... 1.95 kW
Trigger tolerance	± 6°C
Collective resistance of the sensor loop	< 1.65 kW
Terminal voltage	≤ 2.5 V for R ≤ 3.65 kW, ≤ 9 V for R = ∞
Sensor current	≤ 1 mA
Short circuit	20 W ≤ R ≤ 40 W
Power consumption	60 mA

Testing conditions:

EN 60 947-8	
Measurement voltage surge resistance	6000 V
Overvoltage category	III
Degree of pollution	2
Measurement isolation voltage Vbis	690 V



Reliable galvanis isolation until Vi	500 V
Perm. ambient temperature	-20°C ... +60°C
	EN 60068-2-1 Dry heat
Moisture	5 --- 95%, no condensation permissible
EMC resistance	EN61000-6-2
EMC emissions	EN61000-6-4
Vibration resistance	10 ... 1000 Hz 1.14g
Shock resistance	50 g
Safety system values:	
EN 61508, ISO 13849 for Tu = 75°C ongoing	
Category	2
SIL	2 for maintenance cycle of 2 years 1 for maintenance cycle of 3 years
HFT	0
PFD (for yearly functional test)	$4.10 \cdot 10^{-3}$
SFF	90%
$\lambda_s + \lambda_{DD}$	8515 FIT
$\lambda_{DU}$	932 FIT
Ordering number 130B1137	

### 8.1.14. Brake Resistors

In applications where the motor is used as a brake, energy is generated in the motor and sent back into the frequency converter. If the energy can not be transported back to the motor it will increase the voltage in the converter DC-line. In applications with frequent braking and/or high inertia loads this increase may lead to an over voltage trip in the converter and finally a shut down. Brake resistors are used to dissipate the excess energy resulting from the regenerative braking. The resistor is selected in respect to its ohmic value, its power dissipation rate and its physical size. Danfoss offers a wide variety of different resistors that are specially designed to our drive code numbers can be found in section *How to order*.

### 8.1.15. Remote mounting Kit for LCP

The Local Control Panel can be moved to the front of a cabinet by using the remote build in kit. The enclosure is the IP65. The fastening screws must be tightened with a torque of max. 1 Nm.

Technical data	
Enclosure:	IP 65 front
Max. cable length between VLT and unit:	3 m
Communication std:	RS 485

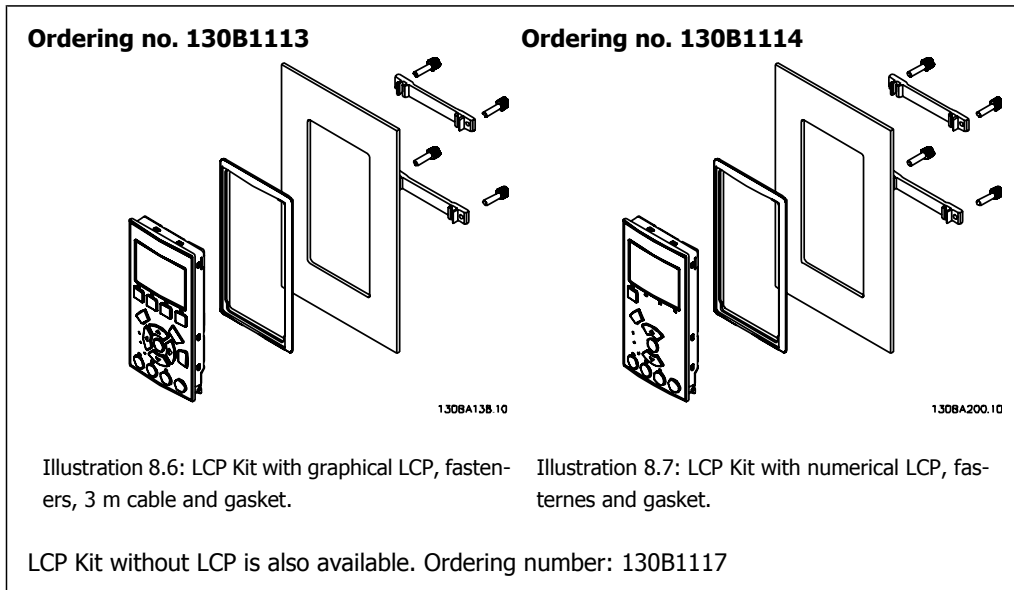

8

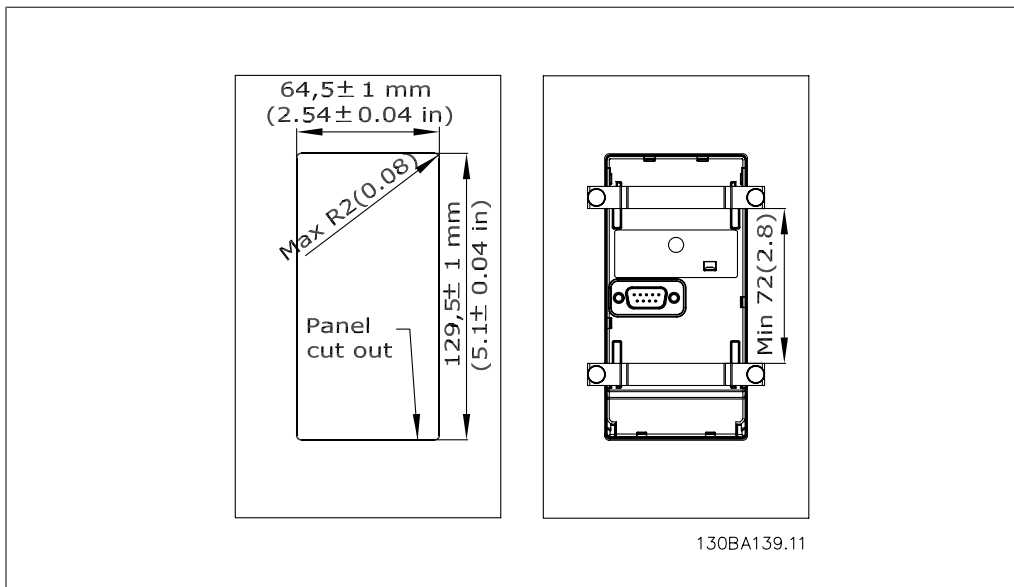

### 8.1.16. IP 21/IP 4X/ TYPE 1 Enclosure Kit

IP 20/IP 4X top/ TYPE 1 is an optional enclosure element available for IP 20 Compact units. If the enclosure kit is used, an IP 20 unit is upgraded to comply with enclosure IP 21/ 4X top/ TYPE 1.

The IP 4X top can be applied to all standard IP 20 FC 30X variants.

### 8.1.17. IP 21/Type 1 Enclosure Kit

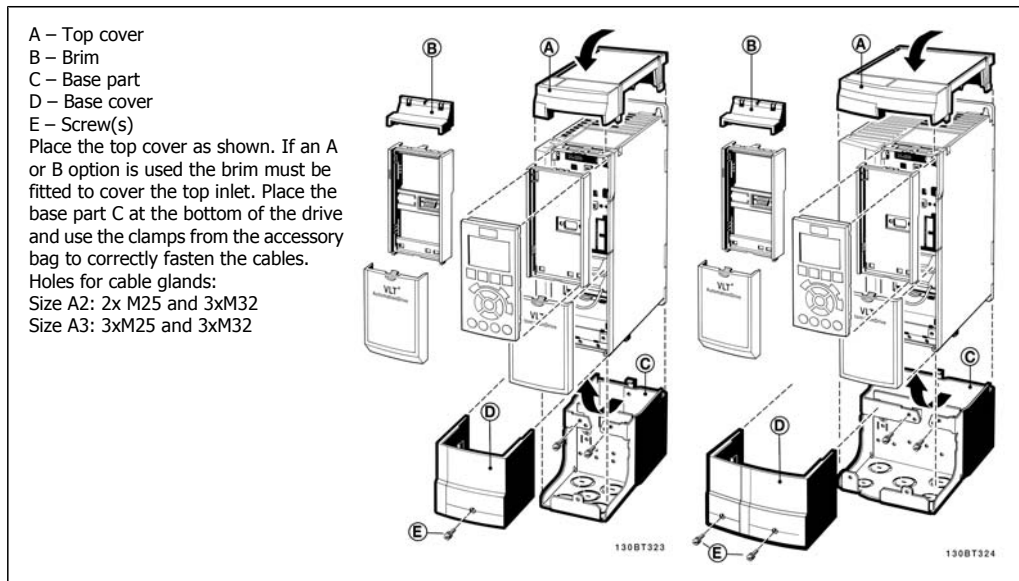

### 8.1.18. Sine-wave Filters

When a motor is controlled by a frequency converter, resonance noise will be heard from the motor. This noise, which is the result of the design of the motor, arises every time an inverter switch in the frequency converter is activated. The frequency of the resonance noise thus corresponds to the switching frequency of the frequency converter.

For the FC 300 Series, Danfoss can supply a Sine-wave filter to dampen the acoustic motor noise.

The filter reduces the ramp-up time of the voltage, the peak load voltage  $U_{PEAK}$  and the ripple current  $\Delta I$  to the motor, which means that current and voltage become almost sinusoidal. Consequently, the acoustic motor noise is reduced to a minimum.

The ripple current in the Sine-wave Filter coils, will also cause some noise. Solve the problem by integrating the filter in a cabinet or similar.



## 9. RS-485 Installation and Set-up

### 9.1. RS-485 Installation and Set-up

#### 9.1.1. Overview

RS-485 is a two-wire bus interface compatible with multi-drop network topology, i.e. nodes can be connected as a bus, or via drop cables from a common trunk line. A total of 32 nodes can be connected to one network segment.

Network segments are divided up by repeaters. Please note that each repeater functions as a node within the segment in which it is installed. Each node connected within a given network must have a unique node address, across all segments.

Terminate each segment at both ends, using either the termination switch (S801) of the frequency converters or a biased termination resistor network. Always use screened twisted pair (STP) cable for bus cabling, and always follow good common installation practice.

Low-impedance ground connection of the screen at every node is very important, including at high frequencies. This can be achieved by connecting a large surface of the screen to ground, for example by means of a cable clamp or a conductive cable gland. It may be necessary to apply potential-equalizing cables to maintain the same ground potential throughout the network, particularly in installations where there are long lengths of cable.

To prevent impedance mismatch, always use the same type of cable throughout the entire network. When connecting a motor to the frequency converter, always use screened motor cable.

Cable: Screened twisted pair (STP)
Impedance: 120 Ohm
Cable length: Max. 1200 m (including drop lines)
Max. 500 m station-to-station

#### 9.1.2. Network Connection

**Connect the frequency converter to the RS-485 network as follows (see also diagram):**

1. Connect signal wires to terminal 68 (P+) and terminal 69 (N-) on the main control board of the frequency converter.
2. Connect the cable screen to the cable clamps.



**NB!**

Screened, twisted-pair cables are recommended in order to reduce noise between conductors.

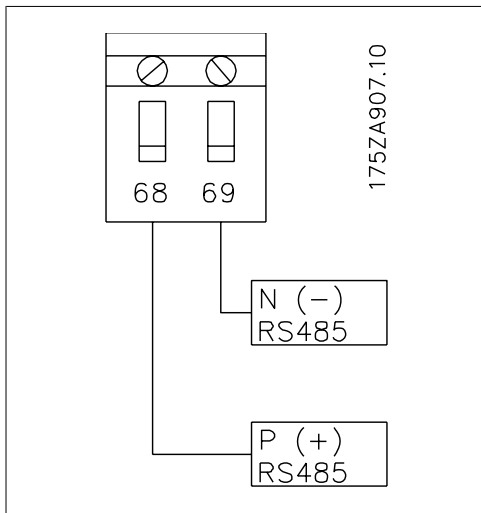
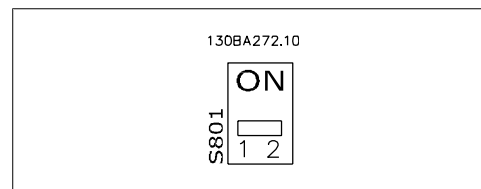

Illustration 9.1: Network Terminal Connection

### 9.1.3. RS 485 Bus Termination

Use the terminator dip switch on the main control board of the frequency converter to terminate the RS-485 bus.

**NB!**  
The factory setting for the dip switch is OFF.



Terminator Switch Factory Setting

### 9.1.4. EMC Precautions

The following EMC precautions are recommended in order to achieve interference-free operation of the RS-485 network.

**NB!**  
Relevant national and local regulations, for example regarding protective earth connection, must be observed. The RS-485 communication cable must be kept away from motor and brake resistor cables to avoid coupling of high frequency noise from one cable to another. Normally a distance of 200 mm (8 inches) is sufficient, but keeping the greatest possible distance between the cables is generally recommended, especially where cables run in parallel over long distances. When crossing is unavoidable, the RS-485 cable must cross motor and brake resistor cables at an angle of 90 degrees.

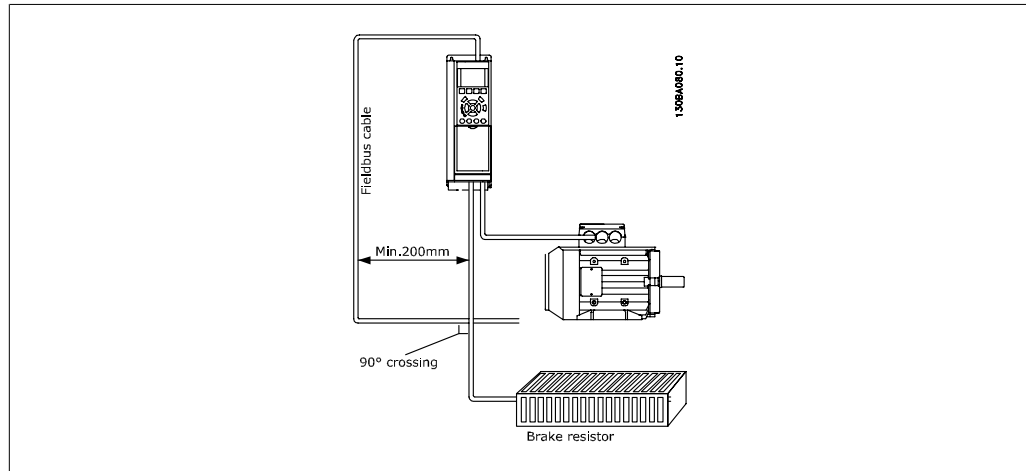

The FC protocol, also referred to as FC bus or Standard bus, is the Danfoss Drives standard fieldbus. It defines an access technique according to the master-slave principle for communications via a serial bus.

One master and a maximum of 126 slaves can be connected to the bus. The individual slaves are selected by the master via an address character in the telegram. A slave itself can never transmit without first being requested to do so, and direct message transfer between the individual slaves is not possible. Communications occur in the half-duplex mode.

The master function cannot be transferred to another node (single-master system).

The physical layer is RS-485, thus utilizing the RS-485 port built into the frequency converter. The FC protocol supports different telegram formats; a short format of 8 bytes for process data, and a long format of 16 bytes that also includes a parameter channel. A third telegram format is used for texts.

### 9.3. Network Configuration

#### 9.3.1. FC 300 Frequency Converter Set-up

Set the following parameters to enable the FC protocol for the FC 300.

Parameter	Num-ber	Parameter name	Setting
8-30		Protocol	FC
8-31		Address	1 - 126
8-32		Baud Rate	2400 - 115200
8-33		Parity/Stop bits	Even parity, 1 stop bit (default)

### 9.4. FC Protocol Message Framing Structure - FC 300

#### 9.4.1. Content of a Character (byte)

Each character transferred begins with a start bit. Then 8 data bits are transferred, corresponding to a byte. Each character is secured via a parity bit, which is set at "1" when it reaches parity (i.e. when there is an equal number of 1's in the 8 data bits and the parity bit in total). A character is completed by a stop bit, thus consisting of 11 bits in all.

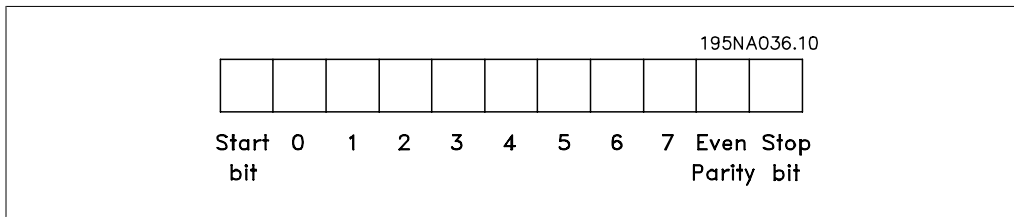

### 9.4.2. Telegram Structure

Each telegram begins with a start character (STX)=02 Hex, followed by a byte denoting the telegram length (LGE) and a byte denoting the frequency converter address (ADR). A number of data bytes (variable, depending on the type of telegram) follows. The telegram is completed by a data control byte (BCC).

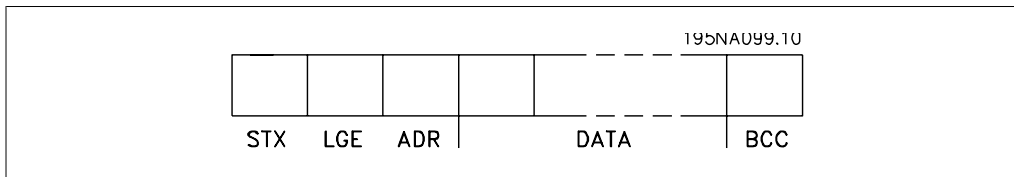

### 9.4.3. Telegram Length (LGE)

The telegram length is the number of data bytes plus the address byte ADR and the data control byte BCC.

The length of telegrams with 4 data bytes is	$LGE = 4 + 1 + 1 = 6$ bytes
The length of telegrams with 12 data bytes is	$LGE = 12 + 1 + 1 = 14$ bytes
The length of telegrams containing texts is	$10^1 + n$ bytes

<sup>1)</sup> The 10 represents the fixed characters, while the "n" is variable (depending on the length of the text).

### 9.4.4. Frequency Converter Address (ADR)

Two different address formats are used.  
The address range of the frequency converter is either 1-31 or 1-126.

1. Address format 1-31:
  - Bit 7 = 0 (address format 1-31 active)
  - Bit 6 is not used
  - Bit 5 = 1: Broadcast, address bits (0-4) are not used
  - Bit 5 = 0: No Broadcast
  - Bit 0-4 = Frequency converter address 1-31

2. Address format 1-126:
  - Bit 7 = 1 (address format 1-126 active)
  - Bit 0-6 = Frequency converter address 1-126
  - Bit 0-6 = 0 Broadcast

The slave returns the address byte unchanged to the master in the response telegram.



### 9.4.5. Data Control Byte (BCC)

The checksum is calculated as an XOR-function. Before the first byte in the telegram is received, the Calculated Checksum is 0.

### 9.4.6. The Data Field

The structure of data blocks depends on the type of telegram. There are three telegram types, and the type applies for both control telegrams (master=>slave) and response telegrams (slave=>master).

The three types of telegram are:

Process block (PCD):

The PCD is made up of a data block of four bytes (2 words) and contains:

- Control word and reference value (from master to slave)
- Status word and present output frequency (from slave to master).

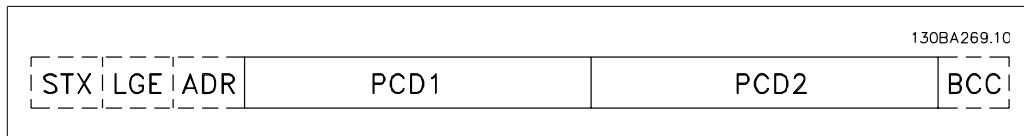

Parameter block:

The parameter block is used to transfer parameters between master and slave. The data block is made up of 12 bytes (6 words) and also contains the process block.

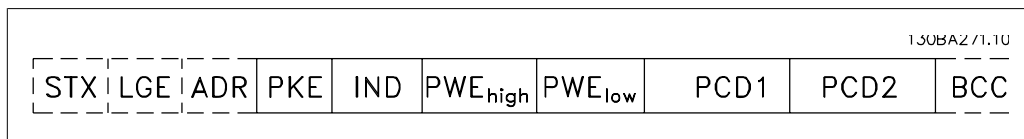

Text block:

The text block is used to read or write texts via the data block.

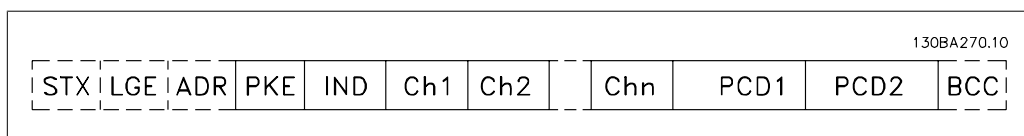

### 9.4.7. The PKE Field

The PKE field contains two sub-fields: Parameter command and response AK, and Parameter number PNU:

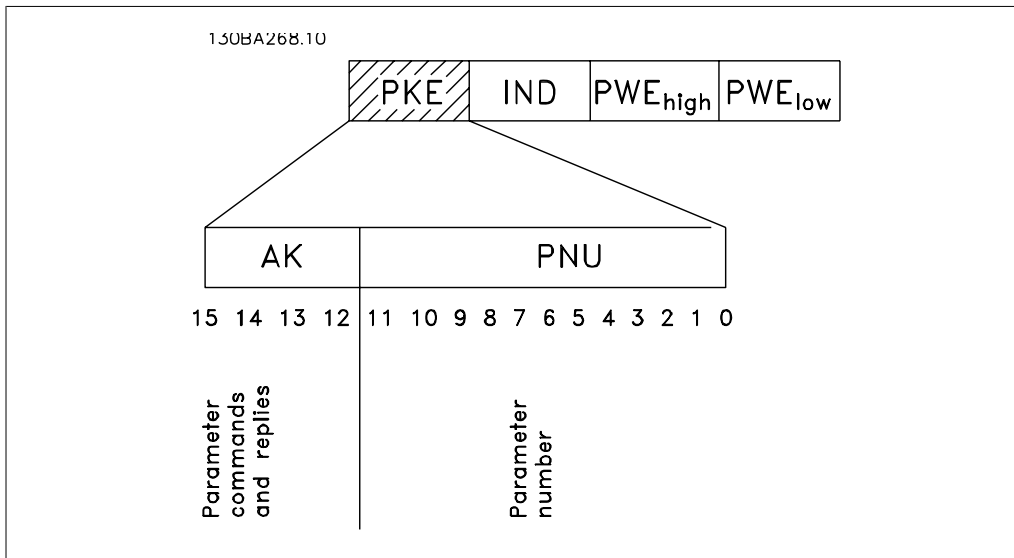

Bits no. 12-15 transfer parameter commands from master to slave and return processed slave responses to the master.

Parameter commands master → slave				
Bit no.		Parameter command		
15	14	13	12	
0	0	0	0	No command
0	0	0	1	Read parameter value
0	0	1	0	Write parameter value in RAM (word)
0	0	1	1	Write parameter value in RAM (double word)
1	1	0	1	Write parameter value in RAM and EEPROM (double word)
1	1	1	0	Write parameter value in RAM and EEPROM (word)
1	1	1	1	Read/write text

Response slave → master				
Bit no.		Response		
15	14	13	12	
0	0	0	0	No response
0	0	0	1	Parameter value transferred (word)
0	0	1	0	Parameter value transferred (double word)
0	1	1	1	Command cannot be performed
1	1	1	1	text transferred

If the command cannot be performed, the slave sends this response:

*0111 Command cannot be performed*

- and issues the following fault report in the parameter value (PWE):

9

PWE low (Hex)	Fault Report
0	The parameter number used does not exist
1	There is no write access to the defined parameter
2	Data value exceeds the parameter's limits
3	The sub index used does not exist
4	The parameter is not the array type
5	The data type does not match the defined parameter
11	Data change in the defined parameter is not possible in the frequency converter's present mode. Certain parameters can only be changed when the motor is turned off
82	There is no bus access to the defined parameter
83	Data change is not possible because factory setup is selected

### 9.4.8. Parameter Number (PNU)

Bits no. 0-11 transfer parameter numbers. The function of the relevant parameter is defined in the parameter description in the Programming Guide.

### 9.4.9. Index (IND)

The index is used together with the parameter number to read/write-access parameters with an index, e.g. par. 15-30 *Error Code*. The index consists of 2 bytes, a low byte and a high byte.

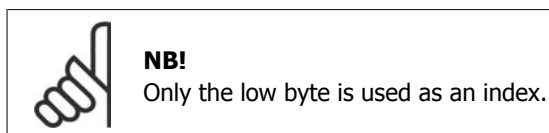

### 9.4.10. Parameter Value (PWE)

The parameter value block consists of 2 words (4 bytes), and the value depends on the defined command (AK). The master prompts for a parameter value when the PWE block contains no value. To change a parameter value (write), write the new value in the PWE block and send from the master to the slave.

When a slave responds to a parameter request (read command), the present parameter value in the PWE block is transferred and returned to the master. If a parameter contains not a numerical value but several data options, e.g. par. 0-01 Language where [0] corresponds to English, and [4] corresponds to Danish, select the data value by entering the value in the PWE block. See Example - Selecting a data value. Serial communication is only capable of reading parameters containing data type 9 (text string).

Parameters 15-40 to 15-53 contain data type 9.

For example, read the unit size and mains voltage range in par. 15-40 *FC Type*. When a text string is transferred (read), the length of the telegram is variable, and the texts are of different lengths. The telegram length is defined in the second byte of the telegram, LGE. When using text transfer the index character indicates whether it is a read or a write command.

To read a text via the PWE block, set the parameter command (AK) to 'F' Hex. The index character high-byte must be "4".

Some parameters contain text that can be written to via the serial bus. To write a text via the PWE block, set the parameter command (AK) to 'F' Hex. The index characters high-byte must be "5".

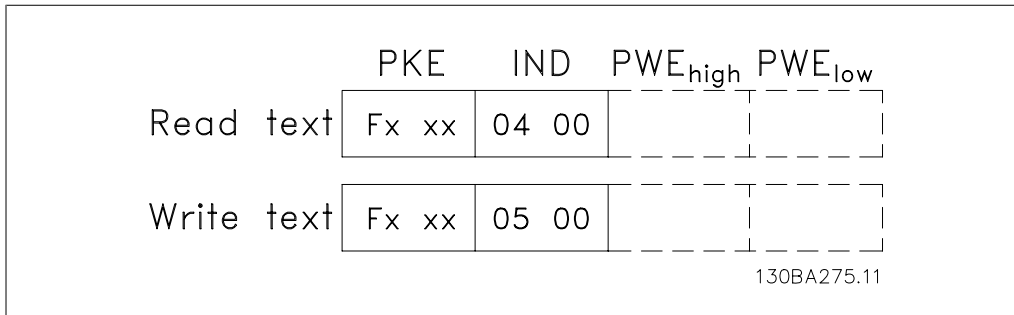

### 9.4.11. Data Types Supported by FC 300

Unsigned means that there is no operational sign in the telegram.

Data types	Description
3	Integer 16
4	Integer 32
5	Unsigned 8
6	Unsigned 16
7	Unsigned 32
9	Text string
10	Byte string
13	Time difference
33	Reserved
35	Bit sequence

### 9.4.12. Conversion

The various attributes of each parameter are displayed in the section Factory Settings. Parameter values are transferred as whole numbers only. Conversion factors are therefore used to transfer decimals.

Par. 4-12 *Motor Speed, Low Limit* has a conversion factor of 0.1.

To preset the minimum frequency to 10 Hz, transfer the value 100. A conversion factor of 0.1 means that the value transferred is multiplied by 0.1. The value 100 is thus perceived as 10.0.

Conversion table	
Conversion index	Conversion factor
74	0.1
2	100
1	10
0	1
-1	0.1
-2	0.01
-3	0.001
-4	0.0001
-5	0.00001

### 9.4.13. Process Words (PCD)

The block of process words is divided into two blocks of 16 bits, which always occur in the defined sequence.

PCD 1	PCD 2
Control telegram (master⇒slave Control word)	Reference-value
Control telegram (slave ⇒master) Status word	Present outp. frequency

## 9.5. Examples

### 9.5.1. Writing a parameter value

Change par. 4-14 *Motor Speed High Limit [Hz]* to 100 Hz.  
Write the data in EEPROM.

PKE = E19E Hex - Write single word in par. 4-14 *Motor Speed High Limit [Hz]*  
IND = 0000 Hex  
PWEHIGH = 0000 Hex  
PWELOW = 03E8 Hex - Data value 1000, corresponding to 100 Hz, see Conversion.

The telegram will look like this:

130BA092.10			
E19E H	0000 H	0000 H	03E8 H
PKE	IND	PWE <sub>high</sub>	PWE <sub>low</sub>

Note: Parameter 4-14 is a single word, and the parameter command for write in EEPROM is "E". Parameter number 414 is 19E in hexadecimal.

130BA093.10			
119E H	0000 H	0000 H	03E8 H
PKE	IND	PWE <sub>high</sub>	PWE <sub>low</sub>

The response from the slave to the master will be:

### 9.5.2. Reading a parameter value

Read the value in par. 3-41 *Ramp 1 Up Time*.

PKE = 1155 Hex - Read parameter value in par. 3-41 *Ramp 1 Up Time*  
IND = 0000 Hex  
PWEHIGH = 0000 Hex  
PWELOW = 0000 Hex

130BA094.10			
1155 H	0000 H	0000 H	0000 H
PKE	IND	PWE <sub>high</sub>	PWE <sub>low</sub>

If the value in par. 3-41 *Ramp 1 Up Time* is 10 s, the response from the slave to the master will be:

130BA267.10			
1155 H	0000 H	0000 H	03E8 H
PKE	IND	PWE <sub>high</sub>	PWE <sub>low</sub>

**NB!**  
3E8 Hex corresponds to 1000 decimal. The conversion index for par. 3-41 is -2, i.e. 0.01.

## 9.6. Danfoss FC Control Profile

### 9.6.1. Control Word According to FC Profile(Par. 8-10 = FC profile)

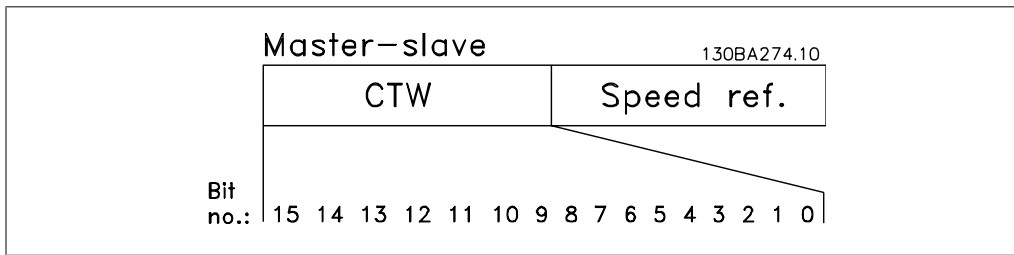

Bit	Bit value = 0	Bit value = 1
00	Reference value	external selection lsb
01	Reference value	external selection msb
02	DC brake	Ramp
03	Coasting	No coasting
04	Quick stop	Ramp
05	Hold output frequency	use ramp
06	Ramp stop	Start
07	No function	Reset
08	No function	Jog
09	Ramp 1	Ramp 2
10	Data invalid	Data valid
11	No function	Relay 01 active
12	No function	Relay 02 active
13	Parameter set-up	selection lsb
14	Parameter set-up	selection msb
15	No function	Reverse

#### Explanation of the Control Bits

##### Bits 00/01

Bits 00 and 01 are used to choose between the four reference values, which are pre-programmed in par. 3-10 *Preset reference* according to the following table:

Programmed ref. value	Par.	Bit 01	Bit 00
1	3-10 [0]	0	0
2	3-10 [1]	0	1
3	3-10 [2]	1	0
4	3-10 [3]	1	1

**NB!**  
Make a selection in par. 8-56 *Preset Reference Select* to define how Bit 00/01 gates with the corresponding function on the digital inputs.

##### Bit 02, DC brake:

Bit 02 = '0' leads to DC braking and stop. Set braking current and duration in par. 2-01 *DC Brake Current* and 2-02 *DC Braking Time* . Bit 02 = '1' leads to ramping.

##### Bit 03, Coasting:

Bit 03 = '0': The frequency converter immediately "lets go" of the motor, (the output transistors are "shut off") and it coasts to a standstill. Bit 03 = '1': The frequency converter starts the motor if the other starting conditions are met.

**NB!**

Make a selection in par. 8-50 *Coasting Select* to define how Bit 03 gates with the corresponding function on a digital input.

Bit 04, Quick stop:

Bit 04 = '0': Makes the motor speed ramp down to stop (set in par. 3-81 *Quick Stop Ramp Time*).

Bit 05, Hold output frequency

Bit 05 = '0': The present output frequency (in Hz) freezes. Change the frozen output frequency only by means of the digital inputs (par. 5-10 to 5-15) programmed to *Speed up* and *Slow down*.

**NB!**

If Freeze output is active, the frequency converter can only be stopped by the following:

- Bit 03 Coasting stop
- Bit 02 DC braking
- Digital input (par. 5-10 to 5-15) programmed to *DC braking*, *Coasting stop*, or *Reset* and *coasting stop*.

Bit 06, Ramp stop/start:

Bit 06 = '0': Causes a stop and makes the motor speed ramp down to stop via the selected ramp down par. Bit 06 = '1': Permits the frequency converter to start the motor, if the other starting conditions are met.

**NB!**

Make a selection in par. 8-53 *Start Select* to define how Bit 06 Ramp stop/start gates with the corresponding function on a digital input.

Bit 07, Reset: Bit 07 = '0': No reset. Bit 07 = '1': Resets a trip. Reset is activated on the signal's leading edge, i.e. when changing from logic '0' to logic '1'.

Bit 08, Jog:

Bit 08 = '1': The output frequency is determined by par. 3-19 *Jog Speed*.

Bit 09, Selection of ramp 1/2:

Bit 09 = "0": Ramp 1 is active (par. 3-40 to 3-47). Bit 09 = "1": Ramp 2 (par. 3-50 to 3-57) is active.

Bit 10, Data not valid/Data valid:

Tell the frequency converter whether to use or ignore the control word. Bit 10 = '0': The control word is ignored. Bit 10 = '1': The control word is used. This function is relevant because the telegram always contains the control word, regardless of the telegram type. Thus, you can turn off the control word if you do not want to use it when updating or reading parameters.

**Bit 11, Relay 01:**

Bit 11 = "0": Relay not activated. Bit 11 = "1": Relay 01 activated provided that *Control word bit 11* is chosen in par. 5-40 *Function relay*.

**Bit 12, Relay 04:**

Bit 12 = "0": Relay 04 is not activated. Bit 12 = "1": Relay 04 is activated provided that *Control word bit 12* is chosen in par. 5-40 *Function relay*.

**Bit 13/14, Selection of set-up:**

Use bits 13 and 14 to choose from the four menu set-ups according to the shown table: .

Set-up	Bit 14	Bit 13
1	0	0
2	0	1
3	1	0
4	1	1

The function is only possible when *Multi Set-Ups* is selected in par. 0-10 *Active Set-Up*

**NB!**  
Make a selection in par. 8-55 *Set-up select* to define how Bit 13/14 gates with the corresponding function on the digital inputs.

**Bit 15 Reverse:**

Bit 15 = '0': No reversing. Bit 15 = '1': Reversing. In the default setting, reversing is set to digital in par. 8-54 *Reversing Select*. Bit 15 causes reversing only when Ser. communication, Logic or or Logic and is selected.

9

### 9.6.2. Status Word According to FC Profile (STW) (Par. 8-10 = FC profile)

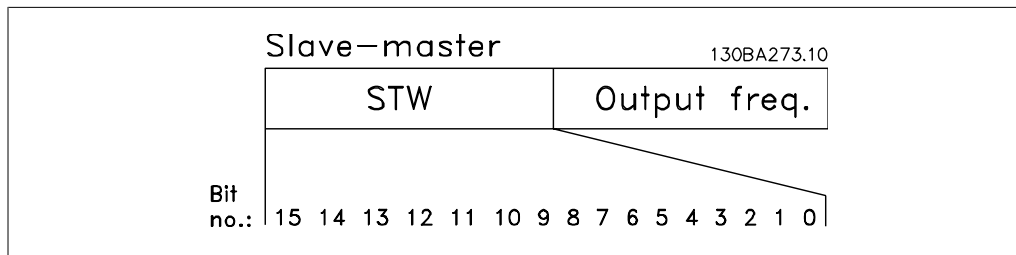

Bit	Bit = 0	Bit = 1
00	Control not ready	Control ready
01	Drive not ready	Drive ready
02	Coasting	Enable
03	No error	Trip
04	No error	Error (no trip)
05	Reserved	-
06	No error	Triplock
07	No warning	Warning
08	Speed ≠ reference	Speed = reference
09	Local operation	Bus control
10	Out of frequency limit	Frequency limit OK
11	No operation	In operation
12	Drive OK	Stopped, auto start
13	Voltage OK	Voltage exceeded
14	Torque OK	Torque exceeded
15	Timer OK	Timer exceeded

**Explanation of the Status Bits**

**Bit 00, Control not ready/ready:**



Bit 00 = '0': The frequency converter trips. Bit 00 = '1': The frequency converter controls are ready but the power component does not necessarily receive any power supply (in case of external 24 V supply to controls).

Bit 01, Drive ready:

Bit 01 = '1': The frequency converter is ready for operation but the coasting command is active via the digital inputs or via serial communication.

Bit 02, Coasting stop:

Bit 02 = '0': The frequency converter releases the motor. Bit 02 = '1': The frequency converter starts the motor with a start command.

Bit 03, No error/trip:

Bit 03 = '0': The frequency converter is not in fault mode. Bit 03 = '1': The frequency converter trips. To re-establish operation, enter [Reset].

Bit 04, No error/error (no trip):

Bit 04 = '0': The frequency converter is not in fault mode. Bit 04 = "1": The frequency converter shows an error but does not trip.

Bit 05, Not used:

Bit 05 is not used in the status word.

Bit 06, No error / triplock:

Bit 06 = '0': The frequency converter is not in fault mode. Bit 06 = "1": The frequency converter is tripped and locked.

Bit 07, No warning/warning:

Bit 07 = '0': There are no warnings. Bit 07 = '1': A warning has occurred.

Bit 08, Speed≠ reference/speed = reference:

Bit 08 = '0': The motor is running but the present speed is different from the preset speed reference. It might e.g. be the case when the speed ramps up/down during start/stop. Bit 08 = '1': The motor speed matches the preset speed reference.

Bit 09, Local operation/bus control:

Bit 09 = '0': [STOP/RESET] is activate on the control unit or *Local control* in par. 3-13 *Reference Site* is selected. You cannot control the frequency converter via serial communication. Bit 09 = '1' It is possible to control the frequency converter via the fieldbus/ serial communication.

Bit 10, Out of frequency limit:

Bit 10 = '0': The output frequency has reached the value in par. 4-11 *Motor Speed Low Limit* or par. 4-13 *Motor Speed High Limit*. Bit 10 = "1": The output frequency is within the defined limits.

Bit 11, No operation/in operation:

Bit 11 = '0': The motor is not running. Bit 11 = '1': The frequency converter has a start signal or the output frequency is greater than 0 Hz.

Bit 12, Drive OK/stopped, autostart:

Bit 12 = '0': There is no temporary over temperature on the inverter. Bit 12 = '1': The inverter stops because of over temperature but the unit does not trip and will resume operation once the over temperature stops.

Bit 13, Voltage OK/limit exceeded:

Bit 13 = '0': There are no voltage warnings. Bit 13 = '1': The DC voltage in the frequency converter's intermediate circuit is too low or too high.

**Bit 14, Torque OK/limit exceeded:**

Bit 14 = '0': The motor current is lower than the torque limit selected in par. 4-18 *Current Limit*.  
 Bit 14 = '1': The torque limit in par. 4-18 *Current Limit* is exceeded.

**Bit 15, Timer OK/limit exceeded:**

Bit 15 = '0': The timers for motor thermal protection and VLT thermal protection are not exceeded 100%. Bit 15 = '1': One of the timers exceeds 100%.

**NB!**  
 All bits in the STW are set to '0' if the connection between the Interbus option and the frequency converter is lost, or an internal communication problem has occurred.

### 9.6.3. Bus Speed Reference Value

Speed reference value is transmitted to the frequency converter in a relative value in %. The value is transmitted in the form of a 16-bit word; in integers (0-32767) the value 16384 (4000 Hex) corresponds to 100%. Negative figures are formatted by means of 2's complement. The Actual Output frequency (MAV) is scaled in the same way as the bus reference.

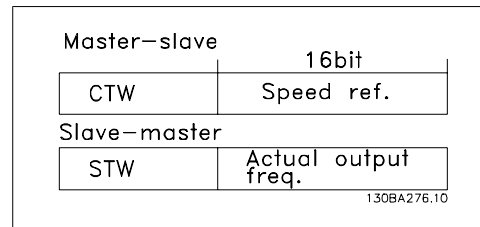

The reference and MAV are scaled as follows:

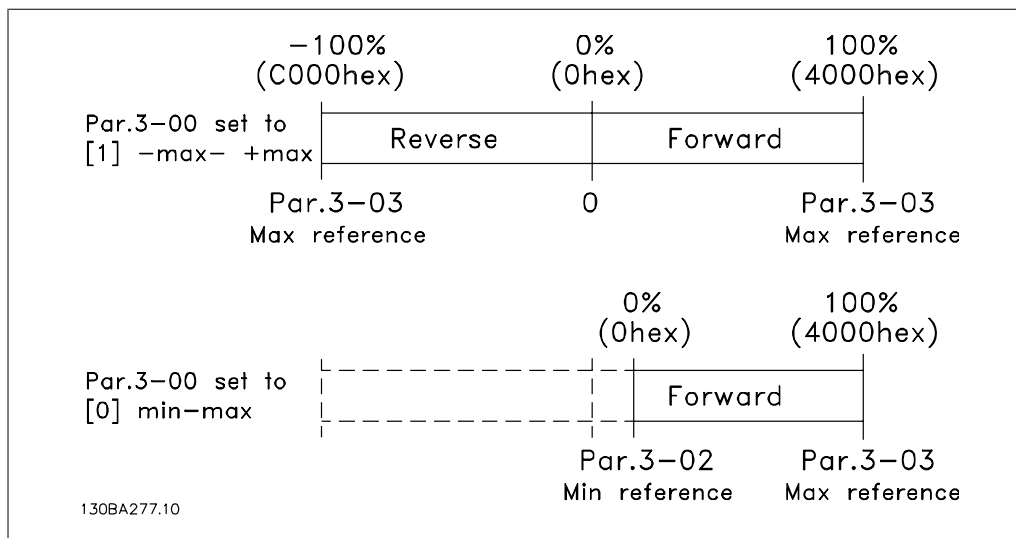

### 9.6.4. PROFIdrive Control Profile

This section describes the functionality of the control word and status word in the PROFIdrive profile. Select this profile by setting par. 8-10 *Control word profile to PROFIdrive*.

### 9.6.5. Control Word according to PROFIdrive Profile (CTW)

The Control word is used to send commands from a master (e.g. a PC) to a slave.

Bit	Bit = 0	Bit = 1
00	OFF 1	ON 1
01	OFF 2	ON 2
02	OFF 3	ON 3
03	Coasting	No coasting
04	Quick stop	Ramp
05	Hold frequency output	Use ramp
06	Ramp stop	Start
07	No function	Reset
08	Jog 1 OFF	Jog 1 ON
09	Jog 2 OFF	Jog 2 ON
10	Data invalid	Data valid
11	No function	Slow down
12	No function	Catch up
13	Parameter set-up	Selection lsb
14	Parameter set-up	Selection msb
15	No function	Reverse

#### Explanation of the Control Bits

##### Bit 00, OFF 1/ON 1

Normal ramp stop using the ramp times of the actual selected ramp.  
 Bit 00 = "0" leads to the stop and activation of the output relay 1 or 2 if the output frequency is 0 Hz and if [Relay 123] has been selected in par. 5-40 *Function relay*.  
 When bit 00 = "1", the frequency converter is in State 1: "Switching on inhibited".  
 Please refer to the PROFIdrive State Transition Diagram, at the end of this section.

##### Bit 01, OFF 2/ON 2

Coasting stop  
 When bit 01 = "0", a coasting stop and activation of the output relay 1 or 2 occurs if the output frequency is 0 Hz and if [Relay 123] has been selected in par. 5-40 *Function relay*.  
 When bit 01 = "1", the frequency converter is in State 1: "Switching on inhibited". Please refer to the PROFIdrive State Transition Diagram, at the end of this section.

##### Bit 02, OFF 3/ON 3

Quick stop using the ramp time of par. 3-81 *Quick stop ramp time*. When bit 02 = "0", a quick stop and activation of the output relay 1 or 2 occurs if the output frequency is 0 Hz and if [Relay 123] has been selected in par. 5-40 *Function relay*.  
 When bit 02 = "1", the frequency converter is in State 1: "Switching on inhibited".  
 Please refer to the PROFIdrive State Transition Diagram, at the end of this section.

##### Bit 03, Coasting/No coasting

Coasting stop Bit 03 = "0" leads to a stop. When bit 03 = "1", the frequency converter can start if the other start conditions are satisfied.

**NB!**  
 The selection in par. 8-50 Coasting select determines how bit 03 is linked with the corresponding function of the digital inputs.

##### Bit 04, Quick stop/Ramp

Quick stop using the ramp time of par. 3-81 *Quick stop ramp time*.

When bit 04 = "0", a quick stop occurs.

When bit 04 = "1", the frequency converter can start if the other start conditions are satisfied.

**NB!**

The selection in par. 8-51 *Quick stop select* determines how bit 04 is linked with the corresponding function of the digital inputs.

Bit 05, Hold frequency output/Use ramp

When bit 05 = "0", the current output frequency is being maintained even if the reference value is modified.

When bit 05 = "1", the frequency converter can perform its regulating function again; operation occurs according to the respective reference value.

Bit 06, Ramp stop/Start

Normal ramp stop using the ramp times of the actual ramp as selected. In addition, activation of the output relay 01 or 04 if the output frequency is 0 Hz if Relay 123 has been selected in par. 5-40 *Function relay*. Bit 06 = "0" leads to a stop. When bit 06 = "1", the frequency converter can start if the other start conditions are satisfied.

**NB!**

The selection in par. 8-53 *Start select* determines how bit 06 is linked with the corresponding function of the digital inputs.

Bit 07, No function/Reset

Reset after switching off.

Acknowledges event in fault buffer.

When bit 07 = "0", no reset occurs.

When there is a slope change of bit 07 to "1", a reset occurs after switching off.

Bit 08, Jog 1 OFF/ON

Activation of the pre-programmed speed in par. 8-90 *Bus Jog 1 speed*. JOG 1 is only possible if bit 04 = "0" and bit 00 - 03 = "1".

Bit 09, Jog 2 OFF/ON

Activation of the pre-programmed speed in par. 8-91 *Bus Jog 2 speed*. JOG 2 is only possible if bit 04 = "0" and bit 00 - 03 = "1".

Bit 10, Data invalid/valid

Is used to tell the frequency converter whether the control word is to be used or ignored. Bit 10 = "0" causes the control word to be ignored, Bit 10 = "1" causes the control word to be used. This function is relevant, because the control word is always contained in the telegram, regardless of which type of telegram is used, i.e. it is possible to turn off the control word if you do not wish to use it in connection with updating or reading parameters.

Bit 11, No function/Slow down

Is used to reduce the speed reference value by the amount given in par. 3-12 *Catch up/slow down* value. When bit 11 = "0", no modification of the reference value occurs. When bit 11 = "1", the reference value is reduced.

Bit 12, No function/Catch up

Is used to increase the speed reference value by the amount given in par. 3-12 *Catch up/slow down value*.

When bit 12 = "0", no modification of the reference value occurs.

When bit 12 = "1", the reference value is increased.

If both - slowing down and accelerating - are activated (bit 11 and 12 = "1"), slowing down has priority, i.e. the speed reference value will be reduced.

**Bits 13/14, Set-up selection**

Bits 13 and 14 are used to choose between the four parameter set-ups according to the following table:

Set-up	Bit 13	Bit 14
1	0	0
2	1	0
3	0	1
4	1	1

The function is only possible if *Multi Set-up* has been chosen in par. 0-10 *Active set-up*. The selection in par. 8-55 *Set-up select* determines how bits 13 and 14 are linked with the corresponding function of the digital inputs. Changing set-up while running is only possible if the set-ups have been linked in par. 0-12 *This set-up linked to*.

**Bit 15, No function/Reverse**

Bit 15 = "0" causes no reversing.

Bit 15 = "1" causes reversing.

Note: In the factory setting reversing is set to *digital* in par. 8-54 *Reversing select*.

**NB!**  
Bit 15 causes reversing only when *Ser. communication, Logic or or Logic and* is selected.

### 9.6.6. Status Word according to PROFIdrive Profile (STW)

The Status word is used to notify a master (e.g. a PC) about the status of a slave.

Bit	Bit = 0	Bit = 1
00	Control not ready	Control ready
01	Drive not ready	Drive ready
02	Coasting	Enable
03	No error	Trip
04	OFF 2	ON 2
05	OFF 3	ON 3
06	Start possible	Start not possible
07	No warning	Warning
08	Speed $\neq$ reference	Speed = reference
09	Local operation	Bus control
10	Out of frequency limit	Frequency limit ok
11	No operation	In operation
12	Drive OK	Stopped, autostart
13	Voltage OK	Voltage exceeded
14	Torque OK	Torque exceeded
15	Timer OK	Timer exceeded

### Explanation of the Status Bits

#### Bit 00, Control not ready/ready

When bit 00 = "0", bit 00, 01 or 02 of the Control word is "0" (OFF 1, OFF 2 or OFF 3) - or the frequency converter is switched off (trip).

When bit 00 = "1", the frequency converter control is ready, but there is not necessarily power supply to the unit present (in the event of external 24 V supply of the control system).

#### Bit 01, VLT not ready/ready

Same significance as bit 00, however, there is a supply of the power unit. The frequency converter is ready when it receives the necessary start signals.

#### Bit 02, Coasting/Enable

When bit 02 = "0", bit 00, 01 or 02 of the Control word is "0" (OFF 1, OFF 2 or OFF 3 or coasting) - or the frequency converter is switched off (trip).

When bit 02 = "1", bit 00, 01 or 02 of the Control word is "1"; the frequency converter has not tripped.

#### Bit 03, No error/Trip

When bit 03 = "0", no error condition of the frequency converter exists.

When bit 03 = "1", the frequency converter has tripped and requires a reset signal before it can start.

#### Bit 04, ON 2/OFF 2

When bit 01 of the Control word is "0", then bit 04 = "0".

When bit 01 of the Control word is "1", then bit 04 = "1".

#### Bit 05, ON 3/OFF 3

When bit 02 of the Control word is "0", then bit 05 = "0".

When bit 02 of the Control word is "1", then bit 05 = "1".

Bit 06, Start possible/Start not possible

If PROFIdrive has been selected in par. 8-10 *Control word profile*, bit 06 will be "1" after a switch-off acknowledgement, after activation of OFF2 or OFF3, and after switching on the mains voltage. Start not possible will be reset, with bit 00 of the Control word being set to "0" and bit 01, 02 and 10 being set to "1".

Bit 07, No warning/Warning

Bit 07 = "0" means that there are no warnings.  
Bit 07 = "1" means that a warning has occurred.

Bit 08, Speed  $\neq$  reference / Speed = reference

When bit 08 = "0", the current speed of the motor deviates from the set speed reference value. This may occur, for example, when the speed is being changed during start/stop through ramp up/down.

When bit 08 = "1", the current speed of the motor corresponds to the set speed reference value.

Bit 09, Local operation/Bus control

Bit 09 = "0" indicates that the frequency converter has been stopped by means of the stop button on the control panel, or that [Linked to hand] or [Local] has been selected in par. 3-13 *Reference site*.

When bit 09 = "1", the frequency converter can be controlled through the serial interface.

Bit 10, Out of frequency limit/Frequency limit OK

When bit 10 = "0", the output frequency is outside the limits set in par. 4-11 *Motor speed low limit (rpm)* and par. 4-13 *Motor speed high limit (rpm)*. When bit 10 = "1", the output frequency is within the indicated limits.

Bit 11, No operation/Operation

When bit 11 = "0", the motor does not turn.

When bit 11 = "1", the frequency converter has a start signal, or the output frequency is higher than 0 Hz.

Bit 12, Drive OK/Stopped, autostart

When bit 12 = "0", there is no temporary overloading of the inverter.

When bit 12 = "1", the inverter has stopped due to overloading. However, the frequency converter has not switched off (trip) and will start again after the overloading has ended.

Bit 13, Voltage OK/Voltage exceeded

When bit 13 = "0", the voltage limits of the frequency converter are not exceeded.

When bit 13 = "1", the direct voltage in the intermediate circuit of the frequency converter is too low or too high.

Bit 14, Torque OK/Torque exceeded

When bit 14 = "0", the motor torque is below the limit selected in par. 4-16 *Torque limit motor mode* and par. 4-17 *Torque limit generator mode*. When bit 14 = "1", the limit selected in par. 4-16 *Torque limit motor mode* or par. 4-17 *Torque limit generator mode* is exceeded.

Bit 15, Timer OK/Timer exceeded

When bit 15 = "0", the timers for the thermal motor protection and thermal frequency converter protection have not exceeded 100%.

When bit 15 = "1", one of the timers has exceeded 100%.

**10**



## 10. Troubleshooting

### 10.1.1. Warnings/Alarm Messages

A warning or an alarm is signalled by the relevant LED on the front of the frequency converter and indicated by a code on the display.

A warning remains active until its cause is no longer present. Under certain circumstances operation of the motor may still be continued. Warning messages may be critical, but are not necessarily so.

In the event of an alarm, the frequency converter will have tripped. Alarms must be reset to restart operation once their cause has been rectified.

**This may be done in three ways:**

1. By using the [RESET] control button on the LCP control panel.
2. Via a digital input with the "Reset" function.
3. Via serial communication/optional fieldbus.



**NB!**

After a manual reset using the [RESET] button on the LCP, the [AUTO ON] button must be pressed to restart the motor.

If an alarm cannot be reset, the reason may be that its cause has not been rectified, or the alarm is trip-locked (see also table on following page).

Alarms that are trip-locked offer additional protection, meaning that the mains supply must be switched off before the alarm can be reset. After being switched back on, the frequency converter is no longer blocked and may be reset as described above once the cause has been rectified.

Alarms that are not trip-locked can also be reset using the automatic reset function in parameters 14-20 (Warning: automatic wake-up is possible!)

If a warning and alarm is marked against a code in the table on the following page, this means that either a warning occurs before an alarm, or else that you can specify whether it is a warning or an alarm that is to be displayed for a given fault.

This is possible, for instance, in parameters 1-90 *Motor Thermal Protection*. After an alarm or trip, the motor carries on coasting, and the alarm and warning flash. Once the problem has been rectified, only the alarm continues flashing until the frequency converter is reset.

No	Description	Warning	Alarm/Trip	Alarm/Trip Lock	Parameter Reference
1	10 Volts low	X			
2	Live zero error	(X)	(X)		6-01
3	No motor	(X)			1-80
4	Mains phase loss	(X)	(X)	(X)	14-12
5	DC link voltage high	X			
6	DC link voltage low	X			
7	DC over-voltage	X	X		
8	DC under voltage	X	X		
9	Inverter overloaded	X	X		
10	Motor ETR over temperature	(X)	(X)		1-90
11	Motor thermistor over temperature	(X)	(X)		1-90
12	Torque limit	X	X		
13	Over Current	X	X	X	
14	Earth Fault	X	X	X	
15	Hardware mismatch		X	X	
16	Short Circuit		X	X	
17	Control word time-out	(X)	(X)		8-04
23	Internal Fan Fault	X			
24	External Fan Fault	X			14-53
25	Brake resistor short-circuited	X			
26	Brake resistor power limit	(X)	(X)		2-13
27	Brake chopper short-circuited	X	X		
28	Brake check	(X)	(X)		2-15
29	Power board over temp	X	X	X	
30	Motor phase U missing	(X)	(X)	(X)	4-58
31	Motor phase V missing	(X)	(X)	(X)	4-58
32	Motor phase W missing	(X)	(X)	(X)	4-58
33	Inrush Fault		X	X	
34	Fieldbus communication fault	X	X		
36	Mains failure	X	X		
38	Internal Fault		X	X	
40	Overload of Digital Output Terminal 27	(X)			5-00, 5-01
41	Overload of Digital Output Terminal 29	(X)			5-00, 5-02
42	Overload of Digital Output On X30/6	(X)			5-32
42	Overload of Digital Output On X30/7	(X)			5-33
47	24 V supply low	X	X	X	
48	1.8 V supply low		X	X	
49	Speed limit	X			
50	AMA calibration failed		X		
51	AMA check $U_{nom}$ and $I_{nom}$		X		
52	AMA low $I_{nom}$		X		
53	AMA motor too big		X		
54	AMA motor too small		X		
55	AMA parameter out of range		X		
56	AMA interrupted by user		X		
57	AMA time-out		X		
58	AMA internal fault	X	X		
59	Current limit	X			

Table 10.1: Alarm/Warning code list

No.	Description	Warning	Alarm/Trip	Alarm/Trip Lock	Parameter Reference
61	Tracking Error	(X)	(X)		4-30
62	Output Frequency at Maximum Limit	X			
63	Mechanical Brake Low		(X)		2-20
64	Voltage Limit	X			
65	Control Board Over-temperature	X	X	X	
66	Heat sink Temperature Low	X			
67	Option Configuration has Changed		X		
68	Safe Stop	(X)	(X) <sup>1)</sup>		5-19
70	Illegal FC configuration			X	
71	PTC 1 Safe Stop	X	X <sup>1)</sup>		5-19
72	Dangerous Failure			X <sup>1)</sup>	5-19
80	Drive Initialized to Default Value		X		
90	Encoder Loss	(X)	(X)		17-61
91	Analogue input 54 wrong settings			X	S202
100-199	See Operating Instructions for MCO 305				
250	New spare part			X	14-23
251	New Type Code		X	X	

Table 10.2: Alarm/Warning code list

(X) Dependent on parameter

1) Can not be Auto reset via Par 14-20

A trip is the action when an alarm has appeared. The trip will coast the motor and can be reset by pressing the reset button or make a reset by a digital input (Par. 5-1\* [1]). The origin event that caused an alarm cannot damage the drive or cause dangerous conditions. A trip lock is an action when an alarm occurs, which may cause damage to drive or

connected parts. A Trip Lock situation can only be reset by a power cycling.

<i>LED indication</i>	
Warning	yellow
Alarm	flashing red
Trip locked	yellow and red

Alarm Word Extended Status Word							
Bit	Hex	Dec	Alarm Word	Alarm Word 2	Warning Word	Warning Word 2	Extended Status Word
0	00000001	1	Brake Check	ServiceTrip, Read/Write	Brake Check		Ramping
1	00000002	2	Pwr. Card Temp	ServiceTrip, (reserved)	Pwr. Card Temp		AMA Running
2	00000004	4	Earth Fault	ServiceTrip, Typecode/ Sparepart	Earth Fault		Start CW/CCW
3	00000008	8	Ctrl.Card Temp	ServiceTrip, (reserved)	Ctrl.Card Temp		Slow Down
4	00000010	16	Ctrl. Word TO	ServiceTrip, (reserved)	Ctrl. Word TO		Catch Up
5	00000020	32	Over Current		Over Current		Feedback High
6	00000040	64	Torque Limit		Torque Limit		Feedback Low
7	00000080	128	Motor Th Over		Motor Th Over		Output Current High
8	00000100	256	Motor ETR Over		Motor ETR Over		Output Current Low
9	00000200	512	Inverter Overld.		Inverter Overld.		Output Freq High
10	00000400	1024	DC under Volt		DC under Volt		Output Freq Low
11	00000800	2048	DC over Volt		DC over Volt		Brake Check OK
12	00001000	4096	Short Circuit		DC Voltage Low		Braking Max
13	00002000	8192	Inrush Fault		DC Voltage High		Braking
14	00004000	16384	Mains ph. Loss		Mains ph. Loss		Out of Speed Range
15	00008000	32768	AMA Not OK		No Motor		OVC Active
16	00010000	65536	Live Zero Error		Live Zero Error		AC Brake
17	00020000	131072	Internal Fault	KTY error	10V Low	KTY Warn	Password Time-lock
18	00040000	262144	Brake Overload	Fans error	Brake Overload	Fans Warn	Password Protection
19	00080000	524288	U phase Loss	ECB error	Brake Resistor	ECB Warn	
20	00100000	1048576	V phase Loss		Brake IGBT		
21	00200000	2097152	W phase Loss		Speed Limit		
22	00400000	4194304	Fieldbus Fault		Fieldbus Fault		Unused
23	00800000	8388608	24 V Supply Low		24V Supply Low		Unused
24	01000000	16777216	Mains Failure		Mains Failure		Unused
25	02000000	33554432	1.8V Supply Low		Current Limit		Unused
26	04000000	67108864	Brake Resistor		Low Temp		Unused
27	08000000	134217728	Brake IGBT		Voltage Limit		Unused
28	10000000	268435456	Option Change		Encoder loss		Unused
29	20000000	536870912	Drive Initialized		Output freq. lim.		Unused
30	40000000	1073741824	Safe Stop (A68)	PTC 1 Safe Stop (A71)	Safe Stop (W68)	PTC 1 Safe Stop (W71)	Unused
31	80000000	2147483648	Mech. brake low	Dangerous Failure (A72)	Extended Word	Status	Unused

Table 10.3: Description of Alarm Word, Warning Word and extended Status Word

The alarm words, warning words and extended status words can be read out via serial bus or optional fieldbus for diagnose. See also par. 16-90 - 16-94.

**WARNING 1, 10 Volts low:**

The 10 V voltage from terminal 50 on the control card is below 10 V.

Remove some of the load from terminal 50, as the 10 V supply is overloaded. Max. 15 mA or minimum 590 Ω.

**WARNING/ALARM 2, Live zero error:**

The signal on terminal 53 or 54 is less than 50% of the value set in par. 6-10, 6-12, 6-20, or 6-22 respectively.

**WARNING/ALARM 3, No motor:**

No motor has been connected to the output of the frequency converter.

**WARNING/ALARM 4, Mains phase loss:**

A phase is missing on the supply side, or the mains voltage imbalance is too high.

This message also appears in case of a fault in the input rectifier on the frequency converter.

Check the supply voltage and supply currents to the frequency converter.

**WARNING 5, DC link voltage high:**

The intermediate circuit voltage (DC) is higher than the overvoltage limit of the control system. The frequency converter is still active.

**WARNING 6, DC link voltage low**

The intermediate circuit voltage (DC) is below the undervoltage limit of the control system. The frequency converter is still active.

**WARNING/ALARM 7, DC over voltage:**

If the intermediate circuit voltage exceeds the limit, the frequency converter trips after a time.

**Possible corrections:**

- Connect a brake resistor
- Extend the ramp time
- Activate functions in par. 2-10
- Increase par. 14-26

Alarm/warning limits:			
FC 300 Series	3 x 200 - 240 V [VDC]	3 x 380 - 500 V [VDC]	3 x 525 - 600 V [VDC]
Undervoltage	185	373	532
Voltage warning low	205	410	585
Voltage warning high (w/o brake - w/brake)	390/405	810/840	943/965
Overvoltage	410	855	975

The voltages stated are the intermediate circuit voltage of the FC 300 with a tolerance of ± 5 %. The corresponding mains voltage is the intermediate circuit voltage (DC-link) divided by 1.35

**WARNING/ALARM 8, DC under voltage:**

If the intermediate circuit voltage (DC) drops below the "voltage warning low" limit (see table above), the frequency converter checks if 24 V backup supply is connected.

If no 24 V backup supply is connected, the frequency converter trips after a given time depending on the unit.

To check whether the supply voltage matches the frequency converter, see *General Specifications*.

**WARNING/ALARM 9, Inverter overloaded:**

The frequency converter is about to cut out because of an overload (too high current for too long). The counter for electronic, thermal inverter protection gives a warning at 98% and trips at 100%, while giving an alarm. You cannot reset the frequency converter until the counter is below 90%.

The fault is that the frequency converter is overloaded by more than 100% for too long.

**WARNING/ALARM 10, Motor ETR over temperature:**

According to the electronic thermal protection (ETR), the motor is too hot. You can choose if you want the frequency converter to give a warning or an alarm when the counter reaches 100% in par. 1-90. The fault is that the motor is overloaded by more than 100% for too long. Check that the motor par. 1-24 is set correctly.

**WARNING/ALARM 11, Motor thermistor over temp:**

The thermistor or the thermistor connection is disconnected. You can choose if you want the frequency converter to give a warning or an alarm when the counter reaches 100% in par. 1-90. Check that the thermistor is connected correctly between terminal 53 or 54 (analog voltage input) and terminal 50 (+ 10 V supply), or between terminal 18 or 19 (digital input PNP only) and terminal 50. If aKTY sensor is used, check for correct connection between terminal 54 and 55.

**WARNING/ALARM 12, Torque limit:**

The torque is higher than the value in par. 4-16 (in motor operation) or the torque is higher than the value in par. 4-17 (in regenerative operation).

**WARNING/ALARM 13, Over Current:**

The inverter peak current limit (approx. 200% of the rated current) is exceeded. The warning will last approx. 8-12 sec., then the frequency converter trips and issues an alarm. Turn off the frequency converter and check if the motor shaft can be turned and if the motor size matches the frequency converter.

If extended mechanical brake control is selected, trip can be reset externally.

**ALARM 14, Earth fault:**

There is a discharge from the output phases to earth, either in the cable between the frequency converter and the motor or in the motor itself.

Turn off the frequency converter and remove the earth fault.

**ALARM 15, Incomplete hardware:**

A fitted option is not handled by the present control board (hardware or software).

**ALARM 16, Short-circuit**

There is short-circuiting in the motor or on the motor terminals.

Turn off the frequency converter and remove the short-circuit.

**WARNING/ALARM 17, Control word timeout:**

There is no communication to the frequency converter.

The warning will only be active when par. 8-04 is NOT set to *OFF*.

If par. 8-04 is set to *Stop* and *Trip*, a warning appears and the frequency converter ramps down until it trips, while giving an alarm.

par. 8-03 *Control word Timeout Time* could possibly be increased.

**WARNING 23, Internal fan fault:**

The fan warning function is an extra protection function that checks if the fan is running / mounted. The fan warning can be disabled in *Fan Monitor*, par. 14-53, (set to [0] Disabled).

**WARNING 24, External fan fault:**

The fan warning function is an extra protection function that checks if the fan is running / mounted. The fan warning can be disabled in *Fan Monitor*, par. 14-53, (set to [0] Disabled).

**WARNING 25, Brake resistor short-circuited:**

The brake resistor is monitored during operation. If it short-circuits, the brake function is disconnected and the warning appears. The frequency converter still works, but without the brake function. Turn off the frequency converter and replace the brake resistor (see par. 2-15 *Brake Check*).

**ALARM/WARNING 26, Brake resistor power limit:**

The power transmitted to the brake resistor is calculated as a percentage, as a mean value over the last 120 s, on the basis of the resistance value of the brake resistor (par. 2-11) and the intermediate circuit voltage. The warning is active when the dissipated braking power is higher than 90%. If *Trip* [2] has been selected in par. 2-13, the frequency converter cuts out and issues this alarm, when the dissipated braking power is higher than 100%.

**ALARM/ WARNING 27, Brake chopper fault:**

The brake transistor is monitored during operation and if it short-circuits, the brake function disconnects and the warning comes up. The frequency converter is still able to run, but since the brake transistor has short-circuited, substantial power is transmitted to the brake resistor, even if it is inactive.

Turn off the frequency converter and remove the brake resistor.

This alarm/ warning could also occur should the brake resistor overheat. Terminal 104 to 106 are available as brake resistor. Klixon inputs, see section Brake Resistor Temperature Switch.



Warning: There is a risk of substantial power being transmitted to the brake resistor if the brake transistor is short-circuited.

**ALARM/WARNING 28, Brake check failed:**

Brake resistor fault: the brake resistor is not connected/working.

**ALARM 29, Drive over temperature:**

If the enclosure is IP 20 or IP 21/Type 1, the cut-out temperature of the heat-sink is 95 °C  $\pm$ 5 °C. The temperature fault cannot be reset, until the temperature of the heatsink is below 70 °C  $\pm$ 5 °C.

**The fault could be:**

- Ambient temperature too high
- Too long motor cable

**ALARM 30, Motor phase U missing:**

Motor phase U between the frequency converter and the the motor is missing. Turn off the frequency converter and check motor phase U.

**ALARM 31, Motor phase V missing:**

Motor phase V between the frequency converter and the motor is missing. Turn off the frequency converter and check motor phase V.

**ALARM 32, Motor phase W missing:**

Motor phase W between the frequency converter and the motor is missing. Turn off the frequency converter and check motor phase W.

**ALARM 33, Inrush fault:**

Too many powerups have occurred within a short time period. See the chapter *General Specifications* for the allowed number of powerups within one minute.

**WARNING/ALARM 34, Fieldbus communication fault:**

The fieldbus on the communication option card is not working.

**WARNING/ALARM 36, Mains failure:**

This warning/alarm is only active if the supply voltage to the frequency converter is lost and parameter 14-10 is NOT set to OFF. Possible

correction: check the fuses to the frequency converter

**ALARM 38, Internal fault:**

By this alarm it may be necessary to contact your Danfoss supplier. Some typical alarm messages:

- 0 The serial port cannot be initialized. Serious hardware failure
- 256 The power EEPROM data is defect or too old
- 512 The control board EEPROM data is defect or too old
- 513 Communication time out Reading EEPROM data
- 514 Communication time out Reading EEPROM data
- 515 The Application Orientated Control cannot recognize the EEPROM data
- 516 Cannot write write to the EEPROM because a write command is on progress
- 517 The write command is under time out
- 518 Failure in the EEPROM
- 519 Missing or invalid BarCode data in EEPROM 1024 – 1279 CAN telegram cannot be sent. (1027 indicate a possible hardware failure)
- 1281 Digital Signal Processor flash time-out
- 1282 Power micro software version mismatch
- 1283 Power EEPROM data version mismatch
- 1284 Cannot read Digital Signal Processor software version
- 1299 Option SW in slot A is too old
- 1300 Option SW in slot B is too old
- 1301 Option SW in slot C0 is too old
- 1302 Option SW in slot C1 is too old
- 1315 Option SW in slot A is not supported (not allowed)
- 1316 Option SW in slot B is not supported (not allowed)
- 1317 Option SW in slot C0 is not supported (not allowed)
- 1318 Option SW in slot C1 is not supported (not allowed)
- 1536 An exception in the Application Orientated Control is registered. Debug information written in LCP
- 1792 DSP watchdog is active. Debugging of power part data Motor Ori-

- entated Control data not transferred correctly
- 2049 Power data restarted
- 2315 Missing SW version from power unit
- 2816 Stack overflow Control board module
- 2817 Scheduler slow tasks
- 2818 Fast tasks
- 2819 Parameter thread
- 2820 LCP stack overflow
- 2821 Serial port overflow
- 2822 USB port overflow
- 3072- Parameter value is outside its limits. Perform a initialization. Parameter number causing the alarm: Subtract the code from 3072. Ex Error code 3238: 3238-3072 = 166 is outside the limit
- 5122
- 5123 Option in slot A: Hardware incompatible with Control board hardware
- 5124 Option in slot B: Hardware incompatible with Control board hardware
- 5125 Option in slot C0: Hardware incompatible with Control board hardware
- 5126 Option in slot C1: Hardware incompatible with Control board hardware
- 5376- Out of memory
- 6231

**WARNING 40, Overload of Digital Output Terminal 27**

Check the load connected to terminal 27 or remove short-circuit connection. Check parameters 5-00 and 5-01.

**WARNING 41, Overload of Digital Output Terminal 29:**

Check the load connected to terminal 29 or remove short-circuit connection. Check parameters 5-00 and 5-02.

**WARNING 42, Overload of Digital Output On X30/6 :**

Check the load connected to X30/6 or remove short-circuit connection. Check parameter 5-32.

**WARNING 42, Overload of Digital Output On X30/7 :**

Check the load connected to X30/7 or remove short-circuit connection. Check parameter 5-33.

**WARNING 47, 24 V supply low:**

The external 24 V DC backup power supply may be overloaded, otherwise Contact your Danfoss supplier.

**WARNING 48, 1.8 V supply low:**

Contact your Danfoss supplier.

**WARNING 49, Speed limit:**

The speed is not within the specified range in par. 4-11 and par. 4-13.

**ALARM 50, AMA calibration failed:**

Contact your Danfoss supplier.

**ALARM 51, AMA check Unom and Inom:**

The setting of motor voltage, motor current, and motor power is presumably wrong. Check the settings.

**ALARM 52, AMA low Inom:**

The motor current is too low. Check the settings.

**ALARM 53, AMA motor too big:**

The motor is too big for the AMA to be carried out.

**ALARM 54, AMA motor too small:**

The motor is too big for the AMA to be carried out.

**ALARM 55, AMA par. out of range:**

The par. values found from the motor are outside acceptable range.

**ALARM 56, AMA interrupted by user:**

The AMA has been interrupted by the user.

**ALARM 57, AMA timeout:**

Try to start the AMA again a number of times, until the AMA is carried out. Please note that repeated runs may heat the motor to a level where the resistance  $R_s$  and  $R_r$  are increased. In most cases, however, this is not critical.

**ALARM 58, AMA internal fault:**

Contact your Danfoss supplier.

**WARNING 59, Current limit:**

The current is higher than the value in par. 4-18.

**WARNING 61, Tracking Error:**

An error between calculated speed and speed measurement from feedback device. The function Warning/Alarm/Disabling setting is in par 4-30. Accepted error setting in par 4-31 and the allowed time the error occur setting in par 4-32. During a commissioning procedure the function may be effective.

**WARNING 62, Output Frequency at Maximum Limit:**

The output frequency is higher than the value set in par. 4-19

**ALARM 63, Mechanical Brake Low:**

The actual motor current has not exceeded the "release brake" current within the "Start delay" time window.

**WARNING 64, Voltage Limit:**

The load and speed combination demands a motor voltage higher than the actual DC link voltage.

**WARNING/ALARM/TRIP 65, Control Card Over Temperature:**

Control card over temperature: The cut-out temperature of the control card is 80° C.

**WARNING 66, Heatsink Temperature Low:**

The heat sink temperature is measured as 0° C. This could indicate that the temperature sensor is defect and thus the fan speed is increased to the maximum in case the power part or control card is very hot.

**ALARM 67, Option Configuration has Changed:**

One or more options has either been added or removed since the last power-down.

**ALARM 68, Safe Stop:**

Safe Stop has been activated. To resume normal operation, apply 24 V DC to T-37, then send a reset signal (via Bus, Digital I/O, or by pressing [RESET]).

**WARNING 68, Safe Stop:**

Safe Stop has been activated. Normal operation is resumed when Safe Stop is disabled. Warning: Automatic Restart!

**ALARM 70, Illegal FC Configuration:**

Actual combination of control board and power board is illegal.

**ALARM 71, PTC 1 Safe Stop:**

Safe Stop has been activated from the MCB 112 PTC Thermistor Card (motor too warm). Normal operation can be resumed when the MCB 112 applies 24 V DC to T-37 again (when the motor temperature reaches an acceptable level) and when the Digital Input from the MCB 112 is deactivated. When that happens, a reset signal must be sent (via Bus, Digital I/O, or by pressing [RESET]).

**WARNING 71, PTC 1 Safe Stop:**

Safe Stop has been activated from the MCB 112 PTC Thermistor Card (motor too warm). Normal operation can be resumed when the MCB 112 applies 24 V DC to T-37 again (when the motor temperature reaches an acceptable level) and when the Digital Input from the MCB 112 is deactivated. Warning: Automatic Restart.



**ALARM 72, Dangerous Failure:**

Safe Stop with Trip Lock. Unexpected signal levels on Safe Stop and Digital Input from the MCB 112 PTC Thermistor Card.

**ALARM 80, Drive Initialised to Default Value:**

Parameter settings are initialised to default setting after a manual (three-finger) reset.

**ALARM 90, Encoder loss:**

Check the connection to encoder option and eventually replace the MCB 102 or MCB 103.

**ALARM 91, Analogue Input 54 Wrong Settings:**

Switch S202 has to be set in position OFF (voltage input) when a KTY sensor is connected to analogue input terminal 54.

**ALARM 250, New Spare Part:**

The power or Switch Mode Power Supply has been exchanged. The frequency converter type code must be restored in the EEPROM. Select the correct type code in Par 14-23 according to the label on unit. Remember to select 'Save to EEPROM' to complete.

**ALARM 251, New Type Code:**

The Frequency Converter has got a new type code.

## Index

### A

Abbreviations	6
Access To Control Terminals	108
Accessory Bag	97
Acoustic Noise	74
Aggressive Environments	16
Air Humidity	16
Alarm Messages	169
Aluminium Conductors	113
Ama	115, 130
Analog Inputs	8
Analog Inputs	70
Analog Inputs	8
Analog Inputs - Terminal X30/11, 12	136
Analog Output	71
Analog Output - Terminal X30/8	136
Automatic Adaptations To Ensure Performance	82
Automatic Motor Adaptation	130
Automatic Motor Adaptation (ama)	115

### B

Basic Wiring Example	110
Brake Connection Option	117
Brake Control	173
Brake Function	45
Brake Power	9, 46
Brake Resistor	43
Brake Resistors	145
Braking Time	158
Break-away Torque	7

### C

Cable Clamp	125
Cable Clamps	122
Cable Length And Cross-section	113
Cable Lengths And Cross Sections	69
Catch Up / Slow Down	26
Ce Conformity And Labelling	15
Clockwise Rotation	119
Coasting	161
Coasting	7, 158
Communication Option	174
Connection To Mains	101
Control Cables	122
Control Cables	112
Control Cables	111
Control Card Performance	73
Control Card, +10 V Dc Output	72
Control Card, 24 V Dc Output	72
Control Card, Rs 485 Serial Communication	71
Control Card, Usb Serial Communication	73
Control Characteristics	72
Control Terminals	108
Control Word	158
Control Word According To Profidrive Profile (ctw)	163
Cooling	82
Cooling Conditions	98

### D

Dc Brake	158
Dc Bus Connection	117
Dc Link	172

Dead Band	28
Dead Band Around Zero	28
Decoupling Plate	104
Definitions	6
Derating For Ambient Temperature	75
Derating For Installing Long Motor Cables Or Cables With Larger Cross-section	82
Derating For Low Air Pressure	81
Derating For Running At Low Speed	82
Devicenet	5, 85
Digital Inputs - Terminal X30/1-4	135
Digital Inputs:	70
Digital Output	72
Digital Outputs - Terminal X30/6, 7	136
Direction Of Motor Rotation	119
Disposal Instruction	14
Drive Configurator	83
<b>E</b>	
Earth Leakage Current	122
Earth Leakage Current	43
Earthing	125
Earthing Of Screened/armoured Control Cables	125
Efficiency	73
Electrical Installation	108, 111, 112
Electrical Installation - Emc Precautions	122
Electrical Terminals	111
Electro-mechanical Brake	129
Emc Directive 89/336/eec	16
Emc Test Results	40
Encoder Feedback	21
Equalising Cable,	125
Etr	119, 173
External 24 V Dc Supply	143
Extreme Running Conditions	49
<b>F</b>	
Fc Profile	158
Flux	23
Freeze Output	7
Freeze Reference	26
Fuses	105
<b>G</b>	
Galvanic Isolation (pelv)	42
General Warning	5
<b>H</b>	
Harmonic Filters	89
High Voltage Test	121
Hoist Mechanical Brake	47
Hold Output Frequency	159
<b>I</b>	
Intermediate Circuit	45, 49, 74, 172
Internal Current Control In Vvcplus Mode	24
<b>J</b>	
Jog	7
Jog	159
<b>K</b>	
Kty Sensor	173

**L**

Lcp	7, 9, 24, 145
Leakage Current	43
Local (hand On) And Remote (auto On) Control	24

**M**

Mains Drop-out	49
Mains Supply	11
Mains Supply	55, 62, 63
Mains Supply (I1, L2, L3)	69
Mains Supply Interference	125
Mechanical Brake	46
Mechanical Dimensions	94, 95, 96
Mechanical Dimensions	93
Mechanical Mounting	98
Moment Of Inertia	49
Motor Cables	122
Motor Cables	112
Motor Connection	103
Motor Feedback	23
Motor Name Plate	115
Motor Output	69
Motor Parameters	130
Motor Phases	49
Motor Protection	69, 119
Motor Rotation	119
Motor Thermal Protection	162
Motor Thermal Protection	50, 120
Motor Voltage	74
Motor-generated Overvoltage	49

**N**

Name Plate Data	115
Non UI Compliance	106

**O**

Ordering Form Type Code	83
Ordering Numbers	83
Ordering Numbers: Brake Resistors	86
Ordering Numbers: Harmonic Filters	89
Ordering Numbers: Options And Accessories	85
Ordering Numbers: Sine Wave Filter Modules, 200-500 Vac	90
Ordering Numbers: Sine-wave Filter Modules, 525-690 Vac	91
Output Performance (u, V, W)	69

**P**

Peak Voltage On Motor	74
Plc	125
Potentiometer Reference	128
Process Pid Control	34
Profibus	5, 85
Programming Of Torque Limit And Stop	129
Protection	16, 42, 43, 105
Protection And Features	69
Pulse Start/stop	127
Pulse/encoder Inputs	71

**R**

Rated Motor Speed	7
Rcd	10, 43
Reference Handling	26

Relay Connection	118
Relay Outputs	72
Removal Of Knockouts For Extra Cables	101
Residual Current Device	43, 126
Rise Time	74
Rs 485 Bus Connection	120
Rs-485	149
<b>S</b>	
Safe Stop	50
Safety Earth Connection	122
Scaling Of References And Feedback	27
Screened/armoured	112
Screening Of Cables	112
Serial Communication	8, 73, 125
Short Circuit (motor Phase – Phase)	49
Side-by-side Installation	98
Sine-wave Filter	105, 147
Sine-wave Filters	147
Smart Logic Control	48
Software Versions	85
Speed Pid	21, 23
Speed Pid Control	31
Start/stop	127
Static Overload In Vvcplus Mode	49
Status Word	160
Status Word According To Profidrive Profile (stw)	165
Surroundings	73
Switches S201, S202, And S801	113
Switching Frequency	113
Switching On The Output	49
<b>T</b>	
The Emc Directive (89/336/eec)	15
The Low-voltage Directive (73/23/eec)	15
The Machinery Directive (98/37/eec)	15
Thermistor	10
Torque Characteristics	69
Torque Control	21
<b>U</b>	
Usb Connection	108
Use Of Emc-correct Cables	123
<b>V</b>	
Vibration And Shock	17
Voltage Level	70
Voltage Reference Via A Potentiometer	128
Vvcplus	10, 22
<b>W</b>	
Warnings	169
What Is Ce Conformity And Labelling?	15
What Is Covered	15