

Contents

1 Introduction	1-1
Approvals	1-1
Symbols	1-1
Abbreviations	1-2
Definitions	1-2
Electrical wiring - Control Cables	1-9
2 How to Program	2-1
The Graphical and Numerical Local Control Panels	2-1
How to Program on the Graphical LCP	2-1
The LCD Display	2-1
Display Mode	2-6
Display Mode - Selection of Readouts	2-6
Parameter Set-up	2-7
Quick Menu Key Functions	2-8
Main Menu Mode	2-10
Parameter Selection	2-10
Infinitely Variable Change of Numeric Data Value	2-12
Read-out and Programming of Indexed Parameters	2-12
How to Program on the Numerical Local Control Panel	2-13
Local Control Keys	2-14
Initialization to Default Settings	2-15
3 Parameter descriptions	3-1
Parameters: Operation and Display	3-2
Parameters: Load and Motor	3-16
Parameters: Brakes	3-35
Parameters: Reference/Ramps	3-40
Parameters: Limits/Warnings	3-54
Parameters: Digital In/Out	3-61
Parameters: Analog In/Out	3-80
Parameters: Controllers	3-92
Parameters: Communications and Options	3-99
Parameters: Profibus	3-114
Parameters: DeviceNet CAN Serial Communication Bus	3-126
Parameters: Ethernet	3-133
IP Settings	3-133

12-1* Eth link par	3-134
12-2* Process Data	3-135
EtherNet/IP	3-135
12-8* Oth. Eth. services	3-137
12-9* Adv. Eth. settings	3-137
Parameters: Smart Logic Control	3-140
Parameters: Special Functions	3-157
Parameters: Drive Information	3-167
Parameters: Data Readouts	3-174
Parameters: Encoder Input	3-183
Parameters: Data Readouts 2	3-186
4 Parameter Lists	4-1
Parameter lists	4-1
5 Troubleshooting	5-1
Warnings/Alarm Messages	5-1
6 Index	6-1

1 Introduction

Programming Guide
Software version: 5.8x

This Programming Guide can be used for all FC 300 adjustable frequency drives with software version 5.8x.
The software version number can be seen from par. 15-43 *Software Version*.

1.1.1 Approvals



1.1.2 Symbols

Symbols used in this guide.

 **NOTE!**
Indicates something to be noted by the reader.

 Indicates a general warning.

 Indicates a high-voltage warning.

* Indicates default setting

1.1.3 Abbreviations

1

Alternating current	AC
American wire gauge	AWG
Ampere/AMP	A
Automatic Motor Adaptation	AMA
Current limit	I _{LIM}
Degrees Celsius	°C
Direct current	DC
Drive Dependent	D-TYPE
Electro Magnetic Compatibility	EMC
Electronic Thermal Relay	ETR
Adjustable Frequency Drive	FC
Gram	g
Hertz	Hz
Kilohertz	kHz
Local Control Panel	LCP
Meter	m
Millihenry Inductance	mH
Milliampere	mA
Millisecond	ms
Minute	min
Motion Control Tool	MCT
Nanofarad	nF
Newton Meters	Nm
Nominal motor current	I _{M,N}
Nominal motor frequency	f _{M,N}
Nominal motor power	P _{M,N}
Nominal motor voltage	U _{M,N}
Parameter	par.
Protective Extra Low Voltage	PELV
Printed Circuit Board	PCB
Rated Inverter Output Current	I _{INV}
Revolutions Per Minute	RPM
Regenerative terminals	Regen
Second	s
Synchronous Motor Speed	n _s
Torque limit	T _{LIM}
Volt	V
The maximum output current	I _{VLT,MAX}
The rated output current supplied by the adjustable frequency drive	I _{VLT,N}

1.1.4 Definitions

Adjustable frequency drive:

I_{VLT,MAX}

Maximum output current.

I_{VLT,N}

Rated output current supplied by the adjustable frequency drive.

U_{VLT,MAX}

Maximum output voltage.

Input:

Control command

Start and stop the connected motor by means of LCP and digital inputs. Functions are divided into two groups.

Functions in group 1 have higher priority than functions in group 2.

Motor:

f_{JOG}

Motor frequency when the jog function is activated (via digital terminals).

f_M

Motor frequency.

Group 1	Reset, Coasting stop, Reset and Coasting stop, Quick-stop, DC braking, Stop and the "Off" key.
Group 2	Start, Pulse start, Reversing, Start reversing, Jog and Freeze output

f_{MAX}

Maximum motor frequency.

 f_{MIN}

Minimum motor frequency.

 $f_{M,N}$

Rated motor frequency (nameplate data).

 I_M

Motor current (actual).

 $I_{M,N}$

Rated motor current (nameplate data).

 $n_{M,N}$

Rated motor speed (nameplate data).

 n_s

Synchronous motor speed

$$n_s = \frac{2 \times \text{par. 1} - 23 \times 60 \text{ s}}{\text{par. 1} - 39}$$

 $P_{M,N}$

Rated motor power (nameplate data in kW or HP).

 $T_{M,N}$

Rated torque (motor).

 U_M

Instantaneous motor voltage.

 $U_{M,N}$

Rated motor voltage (nameplate data).

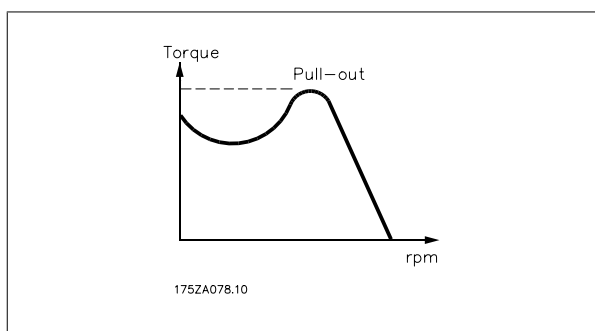
Break-away torque η_{VLT}

The efficiency of the adjustable frequency drive is defined as the ratio between the power output and the power input.

Start-disable command

A stop command belonging to the group 1 control commands - see this group.

Stop command

See Control commands.

References:

Analog Reference

A signal transmitted to the analog inputs 53 or 54, can be voltage or current.

Binary Reference

A signal transmitted to the serial communication port.

Preset Reference

A defined preset reference to be set from -100% to +100% of the reference range. Selection of eight preset references via the digital terminals.

Pulse Reference

A pulse frequency signal transmitted to the digital inputs (terminal 29 or 33).

Ref_{MAX}

Determines the relationship between the reference input at 100% full scale value (typically 10 V, 20mA) and the resulting reference. The maximum reference value set in par. 3-03 *Maximum Reference*.

Ref_{MIN}

Determines the relationship between the reference input at 0% value (typically 0 V, 0 mA, 4 mA) and the resulting reference. The minimum reference value set in par. 3-02 *Minimum Reference*.

Miscellaneous:

Analog Inputs

The analog inputs are used for controlling various functions of the adjustable frequency drive.

There are two types of analog inputs:

Current input, 0–20 mA and 4–20 mA

Voltage input, 0–10 V DC (FC 301)

Voltage input, -10–+10 V DC (FC 302).

Analog Outputs

The analog outputs can supply a signal of 0–20 mA, 4–20 mA.

Automatic Motor Adaptation, AMA

AMA algorithm determines the electrical parameters for the connected motor at standstill.

Brake Resistor

The brake resistor is a module capable of absorbing the braking energy generated in regenerative braking. This regenerative braking energy increases the intermediate circuit voltage and a brake chopper ensures that the power is transmitted to the brake resistor.

CT Characteristics

Constant torque characteristics used for all applications such as conveyor belts, displacement pumps and cranes.

Digital Inputs

The digital inputs can be used for controlling various adjustable frequency drive functions.

Digital Outputs

The adjustable frequency drive features two solid state outputs that can supply a 24 V DC (max. 40 mA) signal.

DSP

Digital Signal Processor.

ETR

Electronic Thermal Relay is a thermal load calculation based on present load and time. Its purpose is to estimate the motor temperature.

Hiperface®

Hiperface® is a registered trademark by Stegmann.

Initializing

If initialization is carried out (par. 14-22 *Operation Mode*), the adjustable frequency drive returns to the default setting.

Intermittent Duty Cycle

An intermittent duty rating refers to a sequence of duty cycles. Each cycle consists of an on-load and an off-load period. The operation can be either periodic duty or non-periodic duty.

LCP

The Local Control Panel makes up a complete interface for control and programming of the adjustable frequency drive. The control panel is detachable and can be installed up to 10 ft [3 m] from the adjustable frequency drive, i.e., in a front panel by means of the installation kit option.

lsb

Least significant bit.

msb

Most significant bit.

MCM

Short for Mille Circular Mil, an American measuring unit for cable cross-sections. 1 MCM = 0.5067 mm².

On-line/Off-line Parameters

Changes to on-line parameters are activated immediately after the data value is changed. Changes to off-line parameters are not activated until you enter [OK] on the LCP.

Process PID

The PID control maintains the desired speed, pressure, temperature, etc. by adjusting the output frequency to match the varying load.

PCD

Process Data

Power Cycle

Switch off line power until display (LCP) is dark – then turn the power on again

Pulse Input/Incremental Encoder

An external, digital pulse transmitter used for feeding back information on motor speed. The encoder is used in applications where great accuracy in speed control is required.

RCD

Residual Current Device.

Set-up

You can save parameter settings in four set-ups. Change between the four parameter set-ups, and edit one set-up, while another set-up is active.

SFAVM

Switching pattern called Stator Flux-oriented Asynchronous Vector Modulation (par. 14-00 *Switching Pattern*).

Slip Compensation

The adjustable frequency drive compensates for the motor slip by giving the frequency a supplement that follows the measured motor load keeping the motor speed almost constant..

Smart Logic Control (SLC)

The SLC is a sequence of user defined actions executed when the associated user defined events are evaluated as true by the Smart Logic Controller. (Parameter group 13-xx Smart Logic Control (SLC)).

STW

Status Word

FC Standard Bus

Includes RS 485 bus with FC protocol or MC protocol. See par. 8-30 *Protocol*.

Thermistor:

A temperature-dependent resistor placed where the temperature is to be monitored (adjustable frequency drive or motor).

Trip

A state entered in fault situations, e.g., if the adjustable frequency drive is subject to an overtemperature or when the adjustable frequency drive is protecting the motor, process or mechanism. Restart is prevented until the cause of the fault has disappeared and the trip state is canceled by activating reset or, in some cases, by being programmed to reset automatically. Trip may not be used for personal safety.

Trip Locked

A state entered in fault situations when the adjustable frequency drive is protecting itself and requiring physical intervention, e.g., if the adjustable frequency drive is subject to a short circuit on the output. A locked trip can only be canceled by cutting off line power, removing the cause of the fault, and reconnecting the adjustable frequency drive. Restart is prevented until the trip state is canceled by activating reset or, in some cases, by being programmed to reset automatically. Trip may not be used for personal safety.

VTC Characteristics

Variable torque characteristics used for pumps and fans.

VVC^{plus}

If compared with standard voltage/frequency ratio control, Voltage Vector Control (VVC^{plus}) improves the dynamics and the stability, both when the speed reference is changed and in relation to the load torque.

60° AVM

Switching pattern called 60° Aynchronous Vector Modulation (par. 14-00 *Switching Pattern*).

Power Factor

The power factor is the relation between I_1 and I_{RMS} .

$$\text{Power factor} = \frac{\sqrt{3} \times U \times I_1 \cos\varphi}{\sqrt{3} \times U \times I_{RMS}}$$

The power factor for 3-phase control:

$$= \frac{I_1 \times \cos\varphi}{I_{RMS}} = \frac{I_1}{I_{RMS}} \text{ since } \cos\varphi = 1$$

The power factor indicates to which extent the adjustable frequency drive imposes a load on the line power supply.

$$I_{RMS} = \sqrt{I_1^2 + I_5^2 + I_7^2 + \dots + I_n^2}$$

The lower the power factor, the higher the I_{RMS} for the same kW performance.

In addition, a high power factor indicates that the different harmonic currents are low.

The adjustable frequency drive's built-in DC coils produce a high power factor, which minimizes the imposed load on the line power supply.

1.1.5 Safety Precautions



The voltage of the adjustable frequency drive is dangerous whenever connected to line power. Incorrect installation of the motor, adjustable frequency drive or serial communication bus may cause death, serious personal injury or damage to the equipment. Consequently, the instructions in this manual, as well as national and local rules and safety regulations, must be complied with.

Safety Regulations

1. The line power supply to the adjustable frequency drive must be disconnected whenever repair work is to be carried out. Make sure that the line power supply has been disconnected and that the necessary time has elapsed before removing motor and line power supply plugs.
2. The [OFF] button on the control panel of the adjustable frequency driver does not disconnect the line power supply and consequently it must not be used as a safety switch.
3. The equipment must be properly grounded, the user must be protected against supply voltage and the motor must be protected against overload in accordance with applicable national and local regulations.
4. The ground leakage current exceeds 3.5 mA.
5. Protection against motor overload is not included in the factory setting. If this function is desired, set par. 1-90 *Motor Thermal Protection* to data value ETR trip 1 [4] or data value ETR warning 1 [3].
6. Do not remove the plugs for the motor and line power supply while the adjustable frequency drive is connected to line power. Make sure that the line power supply has been disconnected and that the necessary time has elapsed before removing motor and line power plugs.
7. Please note that the adjustable frequency drive has more voltage sources than L1, L2 and L3, when load sharing (linking of DC intermediate circuit) or external 24 V DC are installed. Make sure that all voltage sources have been disconnected and that the necessary time has elapsed before commencing repair work.

Warning against unintended start

1. The motor can be brought to a stop by means of digital commands, bus commands, references or a local stop, while the adjustable frequency drive is connected to line power. If personal safety considerations (e.g., risk of personal injury caused by contact with moving machine parts following an unintentional start) make it necessary to ensure that no unintended start occurs, these stop functions are not sufficient. In such cases, the line power supply must be disconnected or the *Safe Stop* function must be activated.
2. The motor may start while setting the parameters. If this means that personal safety may be compromised (e.g., personal injury caused by contact with moving machine parts), motor starting must be prevented, for instance by use of the *Safe Stop* function or secure disconnection of the motor connection.
3. A motor that has been stopped with the line power supply connected, may start if faults occur in the electronics of the adjustable frequency drive, through temporary overload or if a fault in the power supply grid or motor connection is remedied. If unintended start must be prevented for personal safety reasons (e.g., risk of injury caused by contact with moving machine parts), the normal stop functions of the adjustable frequency drive are not sufficient. In such cases, the line power supply must be disconnected or the *Safe Stop* function must be activated.



NOTE!

When using the *Safe Stop* function, always follow the instructions in the *Safe Stop* section of the VLT AutomationDrive FC 300 Design Guide.

4. Control signals from, or internally within, the adjustable frequency drive may in rare cases be activated in error, be delayed or fail to occur entirely. When used in situations where safety is critical, e.g., when controlling the electromagnetic brake function of a hoist application, these control signals must not be relied on exclusively.



Touching the electrical parts may be fatal - even after the equipment has been disconnected from line power.

Also make sure that other voltage inputs have been disconnected, such as external 24 V DC, load sharing (linkage of DC intermediate circuit), as well as the motor connection for kinetic backup.

Systems where adjustable frequency drives are installed must, if necessary, be equipped with additional monitoring and protective devices according to the valid safety regulations, e.g., law on mechanical tools, regulations for the prevention of accidents, etc. Modifications on the adjustable frequency drives by means of the operating software are allowed.

1

Hoisting applications:

The adjustable frequency drive functions for controlling mechanical brakes cannot be considered as a primary safety circuit. There must always be a redundancy for controlling external brakes.

Protection Mode

Once a hardware limit on motor current or DC link voltage is exceeded, the drive will enter "Protection mode". "Protection mode" means a change of the PWM modulation strategy and a low switching frequency to minimize losses. This continues 10 sec after the last fault and increases the reliability and the robustness of the drive while re-establishing full control of the motor.

In hoist applications, "Protection mode" is not usable because the drive will usually not be able to leave this mode again, and therefore it will extend the time before activating the brake – which is not recommended.

"Protection mode" can be disabled by setting par. 14-26 *Trip Delay at Inverter Fault* to zero, which means that the drive will trip immediately if one of the hardware limits is exceeded.

**NOTE!**

It is recommended to disable protection mode in hoisting applications (par. 14-26 *Trip Delay at Inverter Fault* = 0)

1.1.6 Electrical wiring - Control Cables

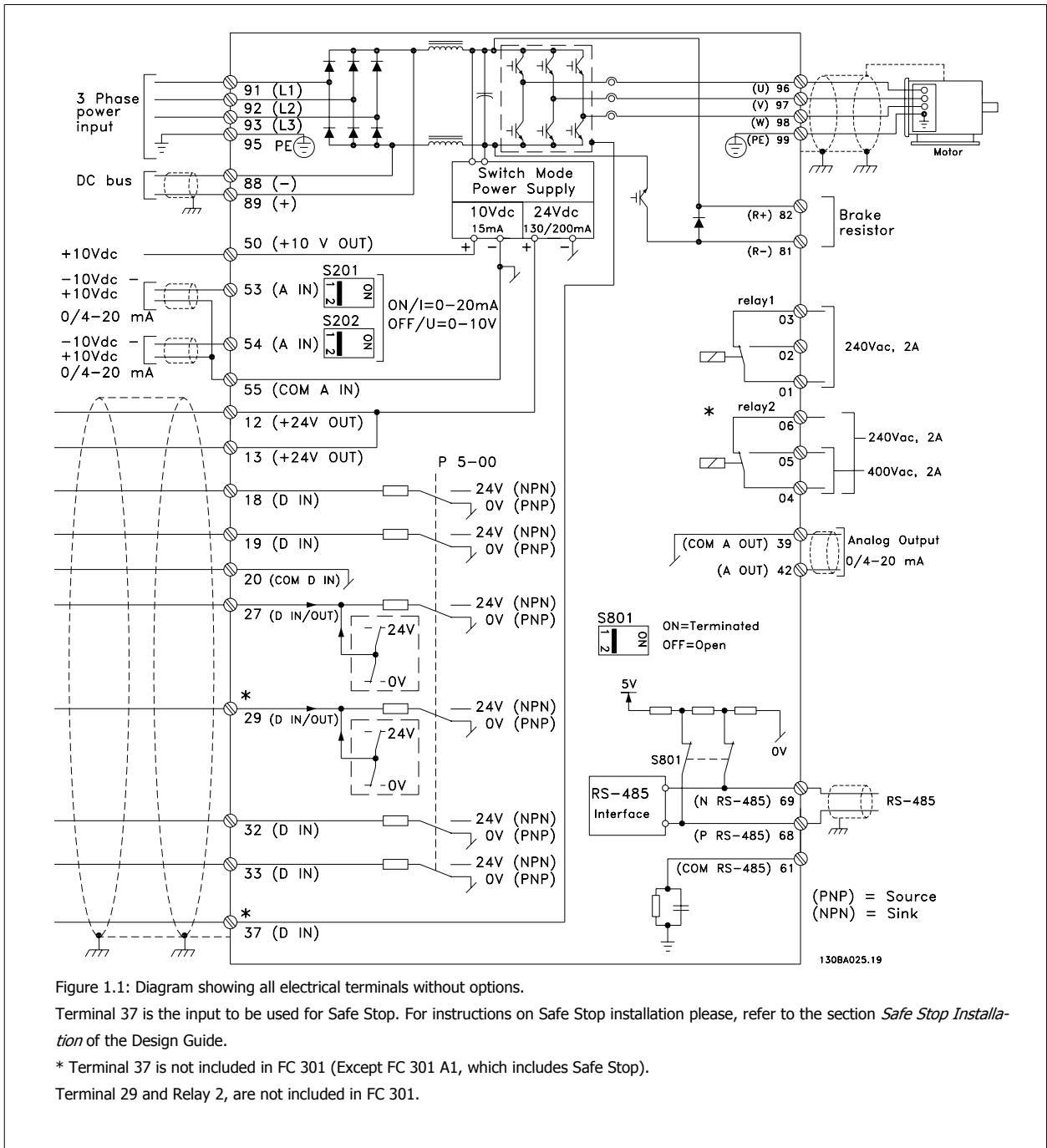

Very long control cables and analog signals may, in rare cases and depending on the installation, result in 50/60 Hz ground loops due to noise from line power supply cables.

If this occurs, it may be necessary to break the shield or insert a 100 nF capacitor between shield and chassis.

The digital and analog inputs and outputs must be connected separately to the common inputs (terminal 20, 55, 39) of the adjustable frequency drive to avoid ground currents from both groups to affect other groups. For example, switching on the digital input may disturb the analog input signal.

1

Input polarity of control terminals

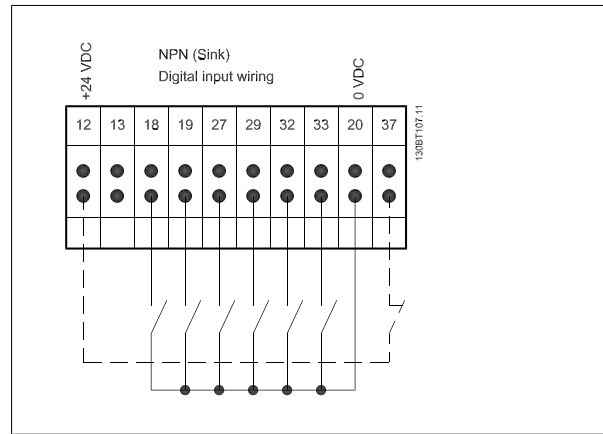
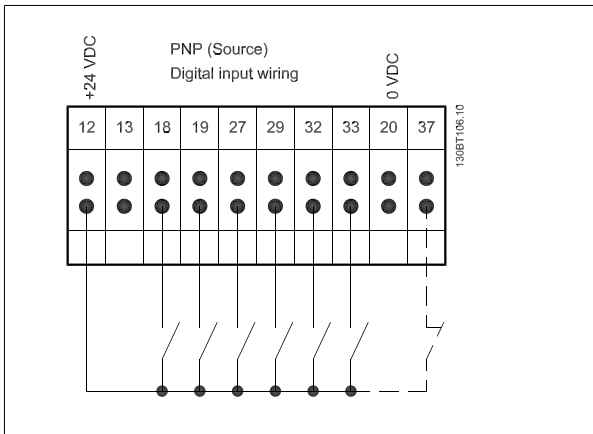

NOTE!
Control cables must be shielded/armored.

See section entitled *Grounding of Shielded/Armored Control Cables* for the correct termination of control cables.

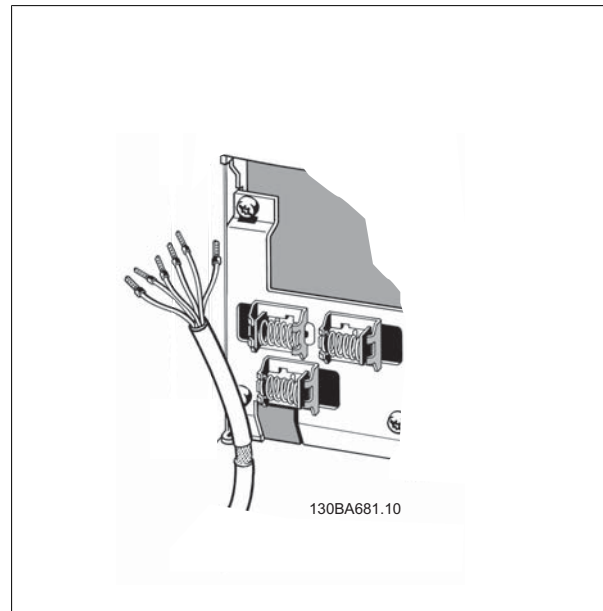

1.1.7 Start/Stop

- Terminal 18 = par. 5-10 *Terminal 18 Digital Input* [8] Start
- Terminal 27 = par. 5-12 *Terminal 27 Digital Input* [0] No operation (Default *coast inverse*)
- Terminal 37 = Safe stop (where available!)

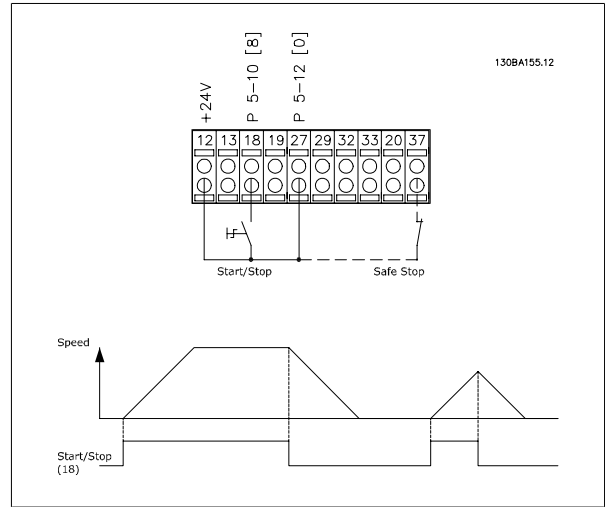

1.1.8 Pulse Start/Stop

- Terminal 18 = par. 5-10 *Terminal 18 Digital Input* Latched start, [9]
- Terminal 27 = par. 5-12 *Terminal 27 Digital Input* Stop inverse, [6]
- Terminal 37 = Safe stop (where available!)

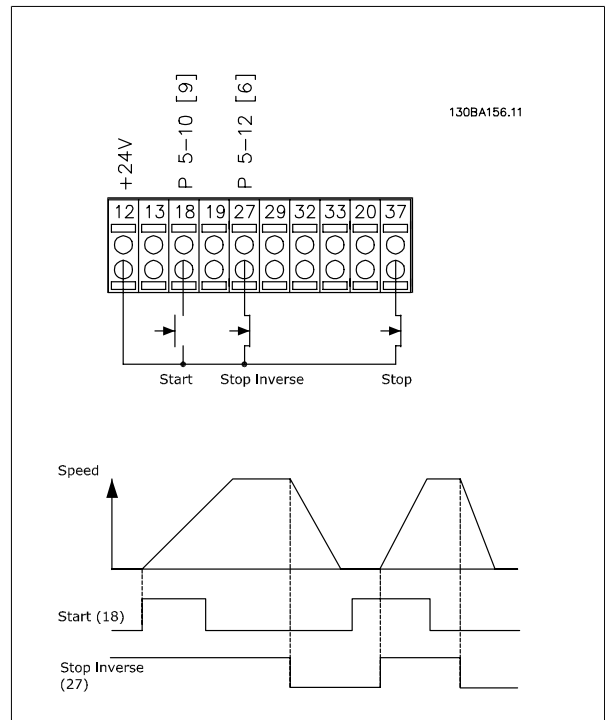

1

1.1.9 Speed Up/Down

Terminals 29/32 = Speed up/down:

Terminal 18 = par. 5-10 *Terminal 18 Digital Input* Start [9] (default)

Terminal 27 = par. 5-12 *Terminal 27 Digital Input* Freeze reference [19]

Terminal 29 = par. 5-13 *Terminal 29 Digital Input* Speed up [21]

Terminal 32 = par. 5-14 *Terminal 32 Digital Input* Slow [22]

NOTE: Terminal 29 only in FC x02 (x=series type).

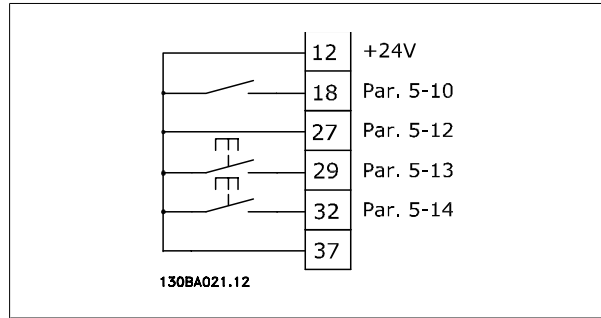

1.1.10 Potentiometer Reference

Voltage reference via a potentiometer:

Reference Source 1 = [1] *Analog input 53* (default)

Terminal 53, Low Voltage = 0 Volt

Terminal 53, High Voltage = 10 Volt

Terminal 53, Low Ref./Feedback = 0 RPM

Terminal 53, High Ref./Feedback = 1,500 RPM

Switch S201 = OFF (U)

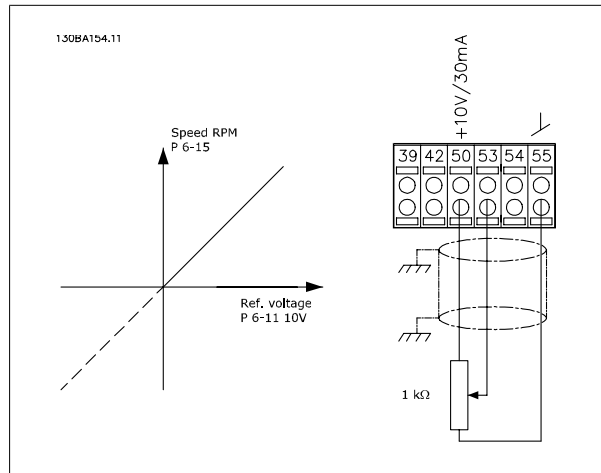

2 How to Program

2.1 The Graphical and Numerical Local Control Panels

The easiest programming of the adjustable frequency drive is performed by the Graphical LCP (102). It is necessary to consult the adjustable frequency drive Design Guide when using the Numeric Local Control Panel (LCP 101).

2.1.1 How to Program on the Graphical LCP

The following instructions are valid for the graphical LCP (LCP 102):

The control panel is divided into four functional groups:

1. Graphical display with Status lines.
2. Menu keys and LEDs - changing parameters and switching between display functions.
3. Navigation keys and LEDs (LEDs).
4. Operation keys and LEDs.

All data is displayed in a graphical LCP display, which can show up to five items of operating data while displaying [Status].

Display lines:

- a. **Status line:** Status messages displaying icons and graphic.
- b. **Line 1-2:** Operator data lines displaying data defined or chosen by the user. By pressing the [Status] key, up to one extra line can be added.
- c. **Status line:** Status messages displaying text.

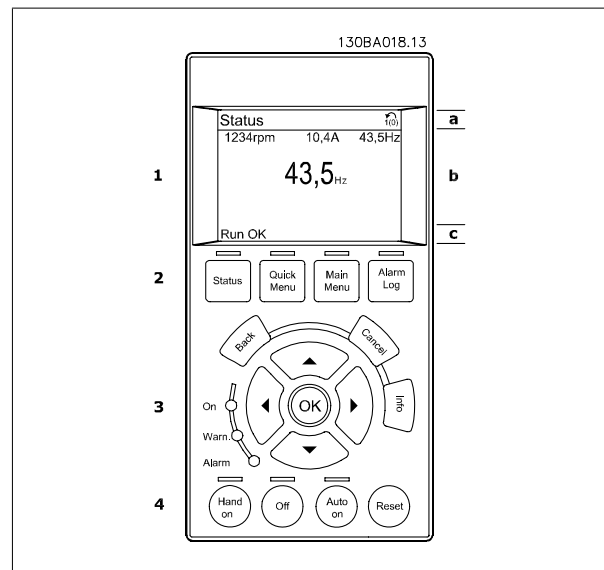

2.1.2 The LCD Display

The LCD display has back lighting and a total of 6 alpha-numeric lines. The display lines show the direction of rotation (arrow), the chosen Set-up as well as the programming Set-up. The display is divided into 3 sections:

Top section shows up to 2 measurements in normal operating status.

The top line in the **Middle section** shows up to 5 measurements with related unit, regardless of status (except in the event of an alarm/warning).

Bottom section always shows the state of the adjustable frequency drive in status mode.

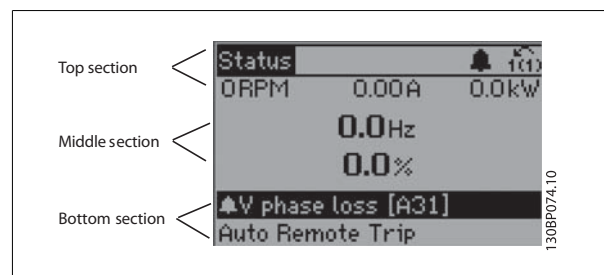

The Active Set-up (selected as the Active Set-up in par. 0-10 *Active Set-up*) is shown. When programming another set-up than the active set-up, the number of the programmed set-up appears to the right.

Display Contrast Adjustment

Press [status] and [▲] for darker display

Press [status] and [▼] for brighter display

Most parameter set-ups can be changed immediately via the control panel, unless a password has been created via par. 0-60 *Main Menu Password* or via par. 0-65 *Quick Menu Password*.

Indicator lights (LEDs):

If certain threshold values are exceeded, the alarm and/or warning LED lights up. A status and alarm text appear on the control panel.

The ON LED is activated when the adjustable frequency drive receives AC line voltage or via a DC bus terminal or 24 V external supply. At the same time, the back light is on.

- Green LED/On: Control section is working.
- Yellow LED/Warn.: Indicates a warning.
- Flashing Red LED/Alarm: Indicates an alarm.

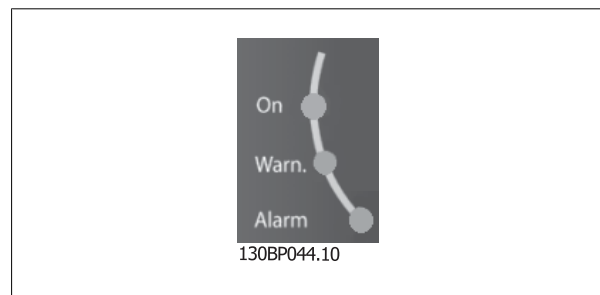

LCPkeys

The control keys are divided into functions. The keys below the display and LEDs are used for parameter Set-up, including choice of display indication during normal operation.

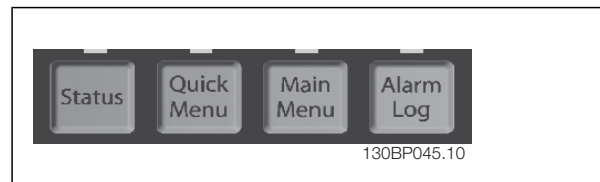

[Status] indicates the status of the adjustable frequency drive and/or the motor. You can choose between 3 different readouts by pressing the [Status] key:

5 line readouts, 4 line readouts or Smart Logic Control.

Use [**Status**] for selecting the mode of display or for changing back to display mode from either the quick menu mode, main menu mode or alarm mode. Also use the [Status] key to toggle single or double readout mode.

[Quick Menu] allows quick access to different quick menus such as:

- My Personal Menu
- Quick Set-up
- Changes Made
- Loggings

Use [**Quick Menu**] for programming the parameters belonging to the Quick Menu. It is possible to switch directly between Quick Menu mode and Main Menu mode.

[**Main Menu**] is used for programming all parameters.

It is possible to switch directly between Main Menu mode and Quick Menu mode.

Parameter shortcut can be carried out by pressing down the [**Main Menu**] key for 3 seconds. The parameter shortcut allows direct access to any parameter.

[Alarm Log] displays an alarm list of the five latest alarms (numbered A1-A5). To obtain additional details about an alarm, use the arrow keys to navigate to the alarm number and press [OK]. You will now receive information about the condition of your adjustable frequency drive right before entering the alarm mode.

[Back] takes you to the previous step or layer in the navigation structure.

[Cancel] annuls your last change or command as long as the display has not been changed.

[Info] supplies information about a command, parameter, or function in any display window. [Info] provides detailed information whenever help is needed.

Exit info mode by pressing either [Info], [Back], or [Cancel].

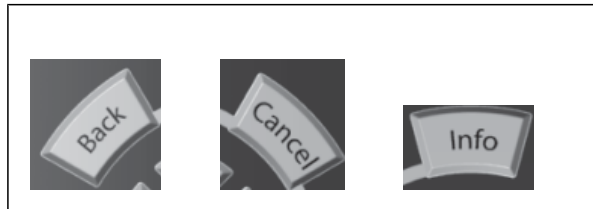

Navigation Keys

The four navigation arrows are used to navigate between the different choices available in **[Quick Menu]**, **[Main Menu]** and **[Alarm Log]**. Use the keys to move the cursor.

[OK] is used for choosing a parameter marked by the cursor and for enabling the change of a parameter.

Local Control Key for local control are found at the bottom of the control panel.



[Hand On] enables control of the adjustable frequency drive via the LCP. [Hand on] also starts the motor, and it is now possible to enter the motor speed data by means of the arrow keys. The key can be selected as Enable [1] or Disable [0] via par. 0-40 *[Hand on] Key on LCP*

External stop signals activated by means of control signals or a serial bus will override a "start" command via the LCP.

The following control signals will still be active when [Hand on] is activated:

- [Hand on] - [Off] - [Auto on]
- Reset
- Coasting stop inverse
- Reversing
- Set-up select bit 0 - Set-up select bit 1
- Stop command from serial communication
- Quick stop
- DC brake

[Off] stops the connected motor. The key can be selected as Enable [1] or Disable [0] via par. 0-41 *[Off] Key on LCP*. If no external stop function is selected and the [Off] key is inactive, the motor can be stopped by disconnecting the voltage.

[Auto On] enables the adjustable frequency drive to be controlled via the control terminals and/or serial communication. When a start signal is applied on the control terminals and/or the bus, the adjustable frequency drive will start. The key can be selected as Enable [1] or Disable [0] via par. 0-42 *[Auto on] Key on LCP*.

**NOTE!**

An active HAND-OFF-AUTO signal via the digital inputs has higher priority than the control keys [Hand on] – [Auto on].

2

[Reset] is used for resetting the adjustable frequency drive after an alarm (trip). It can be selected as *Enable* [1] or *Disable* [0] via par. 0-43 [Reset] Key on LCP.

The **parameter shortcut** can be carried out by holding down the [Main Menu] key for 3 seconds. The parameter shortcut allows direct access to any parameter.

2.1.3 Quick Transfer of Parameter Settings between Multiple Adjustable Frequency Drives

Once the set-up of an adjustable frequency drive is complete, we recommend that you store the data in the LCP or on a PC via MCT 10 Set-up Software Tool.

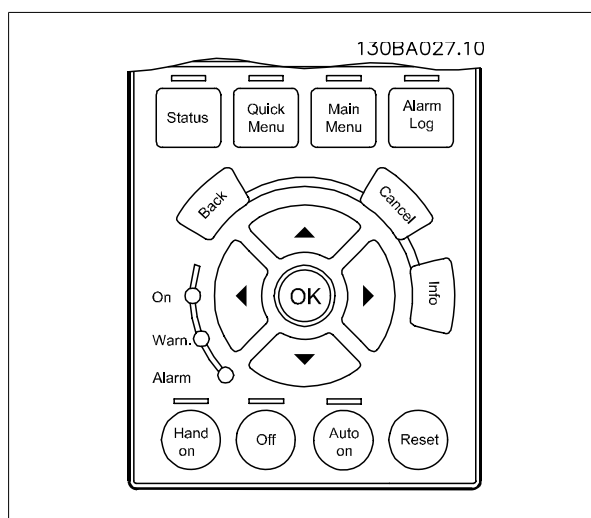
**Data storage in LCP:**

1. Go to par. 0-50 *LCP Copy*
2. Press the [OK] key.
3. Select "All to LCP"
4. Press the [OK] key.

All parameter settings are now stored in the LCP indicated by the progress bar. When 100% is reached, press [OK].

**NOTE!**

Stop the motor before performing this operation.

You can now connect the LCP to another adjustable frequency drive and copy the parameter settings to this adjustable frequency drive as well.

Data transfer from the LCP to the adjustable frequency drive:

1. Go to par. 0-50 *LCP Copy*
2. Press the [OK] key.
3. Select "All from LCP"
4. Press the [OK] key.

The parameter settings stored in the LCP are now transferred to the adjustable frequency drive indicated by the progress bar. When 100% is reached, press [OK].

**NOTE!**

Stop the motor before performing this operation.

2.1.4 Display Mode

In normal operation, up to 5 different operating variables can be indicated continuously in the middle section: 1.1, 1.2, and 1.3 as well as 2 and 3.

2

2.1.5 Display Mode - Selection of Readouts

It is possible to toggle between three status readout screens by pressing the [Status] key.

Operating variables with different formatting are shown in each status screen - see below.

The table shows the measurements you can link to each of the operating variables. When Options are mounted, additional measurements are available. Define the links via par. 0-20 *Display Line 1.1 Small*, par. 0-21 *Display Line 1.2 Small*, par. 0-22 *Display Line 1.3 Small*, par. 0-23 *Display Line 2 Large*, and par. 0-24 *Display Line 3 Large*.

Each readout parameter selected in par. 0-20 *Display Line 1.1 Small* to par. 0-24 *Display Line 3 Large* has its own scale and digits after a possible decimal point. The larger the numeric value for a parameter, the fewer digits displayed after the decimal point.

Ex.: Current readout

5.25 A; 15.2 A 105 A.

Operating variable:	Unit:
Par. 16-00 <i>Control Word</i>	hex
Par. 16-01 <i>Reference [Unit]</i>	[unit]
Par. 16-02 <i>Reference %</i>	%
Par. 16-03 <i>Status Word</i>	hex
Par. 16-05 <i>Main Actual Value [%]</i>	%
Par. 16-10 <i>Power [kW]</i>	[kW]
Par. 16-11 <i>Power [hp]</i>	[HP]
Par. 16-12 <i>Motor voltage</i>	[V]
Par. 16-13 <i>Frequency</i>	[Hz]
Par. 16-14 <i>Motor Current</i>	[A]
Par. 16-16 <i>Torque [Nm]</i>	Nm
Par. 16-17 <i>Speed [RPM]</i>	[RPM]
Par. 16-18 <i>Motor Thermal</i>	%
Par. 16-20 <i>Motor Angle</i>	
Par. 16-30 <i>DC Link Voltage</i>	V
Par. 16-32 <i>Brake Energy /s</i>	kW
Par. 16-33 <i>Brake Energy /2 min</i>	kW
Par. 16-34 <i>Heatsink Temp.</i>	C
Par. 16-35 <i>Inverter Thermal</i>	%
Par. 16-36 <i>Inv. Nom. Current</i>	A
Par. 16-37 <i>Inv. Max. Current</i>	A
Par. 16-38 <i>SL Controller State</i>	
par. 16-39 <i>Control Card Temp.</i>	C
Par. 16-40 <i>Logging Buffer Full</i>	
Par. 16-50 <i>External Reference</i>	
Par. 16-51 <i>Pulse Reference</i>	
Par. 16-52 <i>Feedback [Unit]</i>	[Unit]
Par. 16-53 <i>Digi Pot Reference</i>	
Par. 16-60 <i>Digital Input</i>	bin
Par. 16-61 <i>Terminal 53 Switch Setting</i>	V
Par. 16-62 <i>Analog Input 53</i>	
Par. 16-63 <i>Terminal 54 Switch Setting</i>	V
Par. 16-64 <i>Analog Input 54</i>	
par. 16-65 <i>Analog Output 42 [mA]</i>	[mA]
Par. 16-66 <i>Digital Output [bin]</i>	[bin]
Par. 16-67 <i>Pulse Input #29 [Hz]</i>	[Hz]
Par. 16-68 <i>Freq. Input #33 [Hz]</i>	[Hz]
Par. 16-69 <i>Pulse Output #27 [Hz]</i>	[Hz]
Par. 16-70 <i>Pulse Output #29 [Hz]</i>	[Hz]
Par. 16-71 <i>Relay Output [bin]</i>	
Par. 16-72 <i>Counter A</i>	
Par. 16-73 <i>Counter B</i>	
Par. 16-80 <i>Fieldbus CTW 1</i>	hex
Par. 16-82 <i>Fieldbus REF 1</i>	hex
Par. 16-84 <i>Comm. Option Status</i>	hex
Par. 16-85 <i>FC Port CTW 1</i>	hex
Par. 16-86 <i>FC Port REF 1</i>	hex
Par. 16-90 <i>Alarm Word</i>	
Par. 16-92 <i>Warning Word</i>	
Par. 16-94 <i>Ext. Status Word</i>	

Status screen I:

This readout state is standard after start-up or initialization. Use [INFO] to obtain information about the measurement links to the displayed operating variables (1.1, 1.2, 1.3, 2 and 3). See the operating variables shown on the screen in this figure.

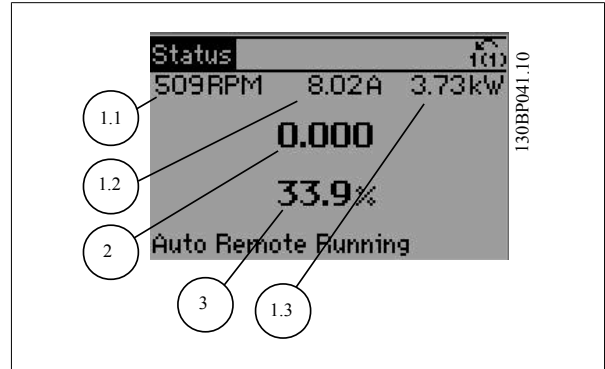

Status screen II:

See the operating variables (1.1, 1.2, 1.3 and 2) shown on the screen in this figure. In the example, Speed, Motor current, Motor power and Frequency are selected as variables in the first and second.

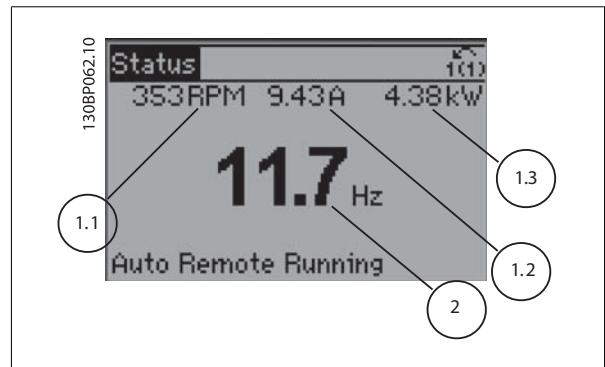

Status screen III:

This state displays the event and action of the Smart Logic Control. For further information, see section *Smart Logic Control*.

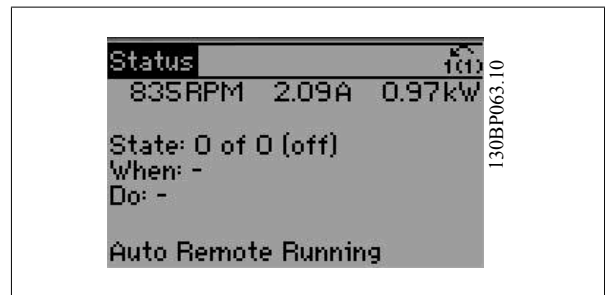

2.1.6 Parameter Set-up

The adjustable frequency drive can be used for practically all assignments, which is why the number of parameters is quite large. The adjustable frequency drive offers a choice between two programming modes - a Main Menu and a Quick Menu mode. The former provides access to all parameters. The latter takes the user through a few parameters, making it possible to start operating the adjustable frequency drive. Regardless of the mode of programming, you can change a parameter both in the main menu and quick menu modes.

2.1.7 Quick Menu Key Functions

Pressing [Quick Menus] The list indicates the different areas contained in the Quick menu.

Select *My Personal Menu* to display the chosen personal parameters. These parameters are selected in par. 0-25 *My Personal Menu*. Up to 20 different parameters can be added in this menu.

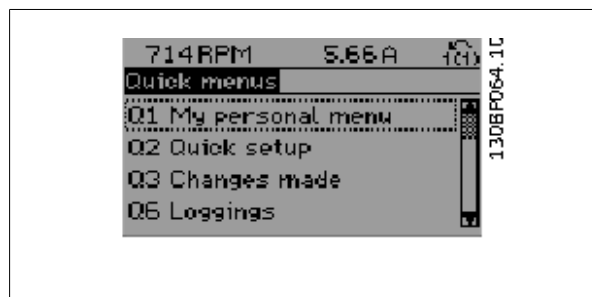

Select *Quick set-up* to go through a limited amount of parameters to get the motor running almost optimally. The default setting for the other parameters considers the desired control functions and the configuration of signal inputs/outputs (control terminals).

Parameters are selected by using the arrow keys. The parameters in the following table are accessible.

Parameter	Setting
Par. 0-01 <i>Language</i>	
Par. 1-20 <i>Motor Power [kW]</i>	[kW]
Par. 1-22 <i>Motor Voltage</i>	[V]
Par. 1-23 <i>Motor Frequency</i>	[Hz]
Par. 1-24 <i>Motor Current</i>	[A]
Par. 1-25 <i>Motor Nominal Speed</i>	[rpm]
Par. 5-12 <i>Terminal 27 Digital Input</i>	[0] No function*
Par. 1-29 <i>Automatic Motor Adaptation (AMA)</i>	[1] Enable complete AMA
Par. 3-02 <i>Minimum Reference</i>	[rpm]
Par. 3-03 <i>Maximum Reference</i>	[rpm]
Par. 3-41 <i>Ramp 1 Ramp-up Time</i>	[sec]
Par. 3-42 <i>Ramp 1 Ramp-down Time</i>	[sec]
Par. 3-13 <i>Reference Site</i>	

* If terminal 27 is set to "no function", no connection to +24 V on terminal 27 is necessary.

Select *Changes made* to get information about:

- the last 10 changes. Use the [▲] [▼] navigation keys to scroll between the last 10 changed parameters.
- the changes made since default setting.

Select *Loggings* to get information about the display line readouts. The information is shown as graphs.

Only display parameters selected in par. 0-20 *Display Line 1.1 Small* and par. 0-24 *Display Line 3 Large* can be viewed. It is possible to store up to 120 samples in the memory for later reference.

2.1.8 Initial Commissioning

The easiest way of carrying out the initial commissioning is by using the quick menu button and follow the quick set-up procedure using LCP 102 (read table from left to right). The example applies to open-loop applications:

Press			
		Q2 Quick Menu	
Par. 0-01 <i>Language</i>		Set language	
Par. 1-20 <i>Motor Power [kW]</i>		Set motor nameplate power	
Par. 1-22 <i>Motor Voltage</i>		Set nameplate voltage	
Par. 1-23 <i>Motor Frequency</i>		Set nameplate frequency	
Par. 1-24 <i>Motor Current</i>		Set nameplate current	
Par. 1-25 <i>Motor Nominal Speed</i>		Set nameplate speed in RPM	
Par. 5-12 <i>Terminal 27 Digital Input</i>		If terminal default is <i>Coast inverse</i> , it is possible to change this setting to <i>No function</i> . No connection to terminal 27 is then needed for running AMA	
Par. 1-29 <i>Automatic Motor Adaptation (AMA)</i>		Set desired AMA function. Enable complete AMA is recommended	
Par. 3-02 <i>Minimum Reference</i>		Set the minimum speed of the motor shaft	
Par. 3-03 <i>Maximum Reference</i>		Set the maximum speed of the motor shaft	
Par. 3-41 <i>Ramp 1 Ramp-up Time</i>		Set the ramping-up time with reference to synchronous motor speed, ns.	
Par. 3-42 <i>Ramp 1 Ramp-down Time</i>		Set the ramping-down time with reference to synchronous motor speed, ns.	
Par. 3-13 <i>Reference Site</i>		Set the site from where the reference must work	

2.1.9 Main Menu Mode

Start main menu mode by pressing the [Main Menu] key. The readout shown to the right appears on the display.

The middle and bottom sections on the display show a list of parameter groups which can be chosen by toggling the up and down buttons.

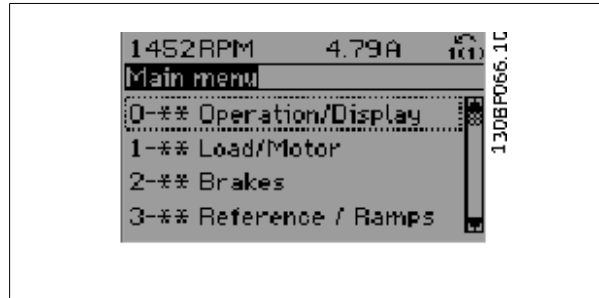

Each parameter has a name and number which remain the same regardless of the programming mode. In main menu mode, the parameters are divided into groups. The first digit of the parameter number (from the left) indicates the parameter group number.

All parameters can be changed in the main menu. However, depending on the choice of configuration (par. 1-00 *Configuration Mode*), some parameters can be "missing". For example, open-loop hides all the PID parameters, and other enabled options make more parameter groups visible.

2.1.10 Parameter Selection

In main menu mode, the parameters are divided into groups. You select a parameter group by means of the navigation keys.

The following parameter groups are accessible:

Group no.	Parameter group:
0	Operation/Display
1	Load/Motor
2	Brakes
3	References/Ramps
4	Limits/Warnings
5	Digital In/Out
6	Analog In/Out
7	Controls
8	Comm. and Options
9	Profibus
10	CAN Serial Communication Bus
11	Reserved Com. 1
12	Reserved Com. 2
13	Smart Logic
14	Special Functions
15	Drive Information
16	Data Readouts
17	Motor Feedb. Option
18	Data Readouts 2
30	Special Features
32	MCO Basic Settings
33	MCO Adv. Settings
34	MCO Data Readouts

After selecting a parameter group, choose a parameter by means of the navigation keys.

The middle section on the display shows the parameter number and name as well as the selected parameter value.

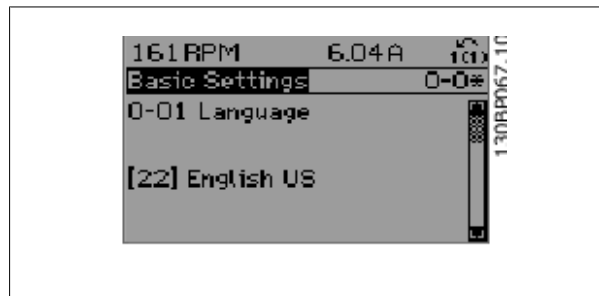

2.1.11 Changing Data

The procedure for changing data is the same whether you select a parameter in the quick menu or the main menu mode. Press [OK] to change the selected parameter.

The procedure for changing data depends on whether the selected parameter represents a numerical data value or a text value.

2.1.12 Changing a Text Value

If the selected parameter is a text value, change the text value by means of the [▲] [▼] navigation keys.

The up key increases the value, and the down key decreases the value.

Place the cursor on the value you want to save and press [OK].



2.1.13 Changing a Group of Numeric Data Values

If the chosen parameter represents a numeric data value, change the chosen data value by means of the [◀] [▶] navigation keys as well as the [▲] [▼] navigation keys. Use the [◀] [▶] navigation keys to move the cursor horizontally.

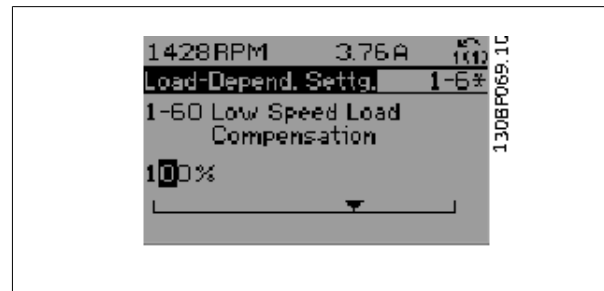

Use the [▲] [▼] navigation keys to change the data value. The up key enlarges the data value, and the down key reduces the data value. Place the cursor on the value you want to save and press [OK].

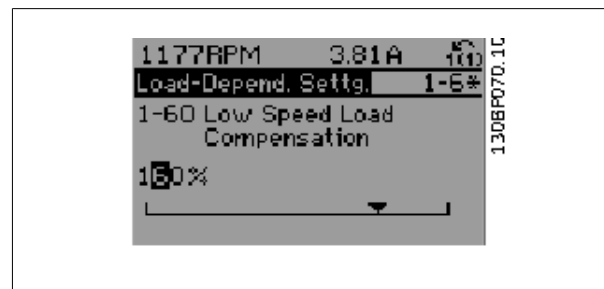

2.1.14 Infinitely Variable Change of Numeric Data Value

If the chosen parameter represents a numeric data value, select a digit by means of the [◀] [▶] navigation keys.

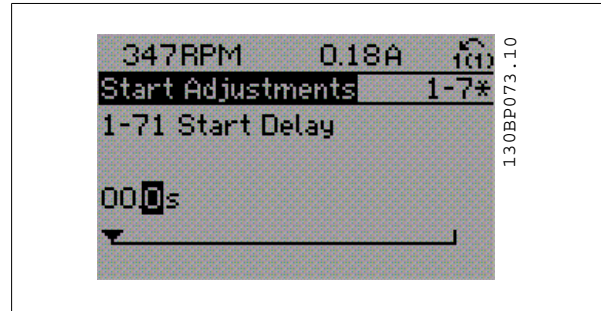

Change the selected digit infinitely variably by means of the [▲] [▼] navigation keys.

The chosen digit is indicated by the cursor. Place the cursor on the digit you want to save and press [OK].

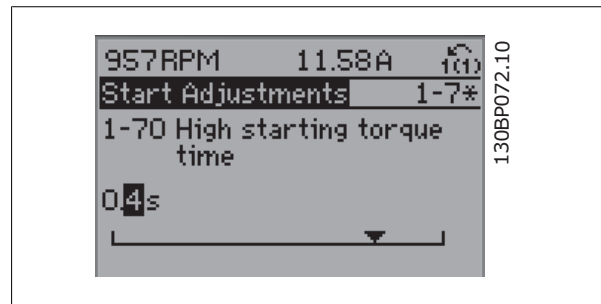

2.1.15 Changing a Data Value, Step-by-Step

Certain parameters can be changed step by step or infinitely varying. This applies to par. 1-20 *Motor Power [kW]*, par. 1-22 *Motor Voltage* and par. 1-23 *Motor Frequency*.

The parameters are changed both as a group of numeric data values and as numeric data values infinitely varying.

2.1.16 Read-out and Programming of Indexed Parameters

Parameters are indexed when placed in a rolling stack.

Par. 15-30 *Fault Log: Error Code* to par. 15-32 *Alarm Log: Time* contain a fault log which can be read out. Choose a parameter, press [OK], and use the [▲] [▼] navigation keys to scroll through the value log.

Use par. 3-10 *Preset Reference* as another example:

Choose the parameter, press [OK], and use the [▲] [▼] navigation keys to scroll through the indexed values. To change the parameter value, select the indexed value and press [OK]. Change the value by using the [▲] [▼] keys. Press [OK] to accept the new setting. Press [CANCEL] to abort. Press [Back] to leave the parameter.

2.1.17 How to Program on the Numerical Local Control Panel

The following instructions are valid for the Numerical LCP (LCP 101).
 The control panel is divided into four functional groups:

1. Numerical display.
2. Menu keys and LEDs - changing parameters and switching between display functions.
3. Navigation keys and indicator lights (LEDs).
4. Operation keys and indicator lights (LEDs).

Display line: Status messages displaying icons and numeric value.

LEDs:

- Green LED/On: Indicates if control section is on.
- Yellow LED/Wrn.: Indicates a warning.
- Flashing red LED/Alarm: Indicates an alarm.

LCP keys

[Menu] Select one of the following modes:

- Status
- Quick Set-up
- Main Menu

Status Mode: Displays the status of the adjustable frequency drive or the motor.

If an alarm occurs, the NLCP automatically switches to status mode.

A number of alarms can be displayed.

NOTE!
 Parameter copy is not possible with LCP 101 Numerical Local Control Panel.

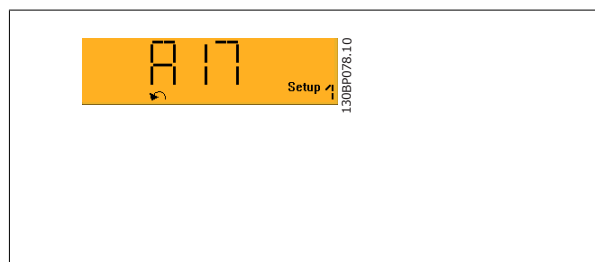
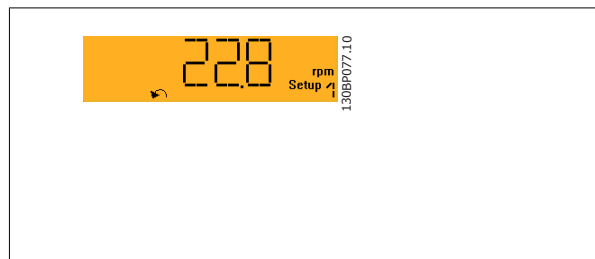
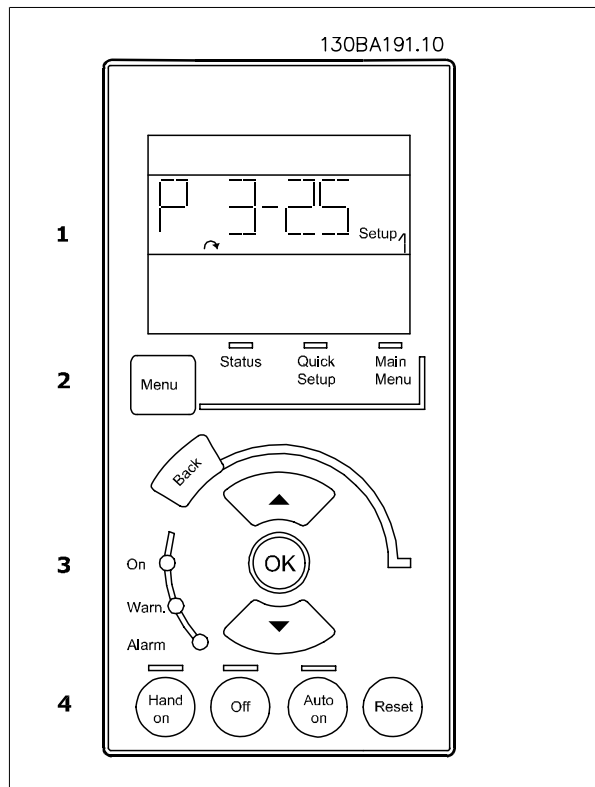

Main Menu/Quick Set-up is used for programming all parameters or only the parameters in the quick menu (see also description of the LCP 102 earlier in this chapter).

The parameter values can be changed using the [▲] [▼] keys when the value is flashing.

Select the main menu by pressing the [Menu] key several times.

Select the parameter group [xx-__] and press [OK]

Select the parameter [__-xx] and press [OK]

If the parameter is an array parameter, select the array number and press [OK]

Select the wanted data value and press [OK]

Parameters with functional choices display values such as [1], [2], etc.

For a description of the different choices, see the individual description of the parameters in the *Parameter Selection* section

[Back] for stepping backwards

Arrow [▲] [▼] keys are used for navigating between commands and within parameters.

2.1.18 Local Control Keys

Keys for local control are found at the bottom of the LCP.

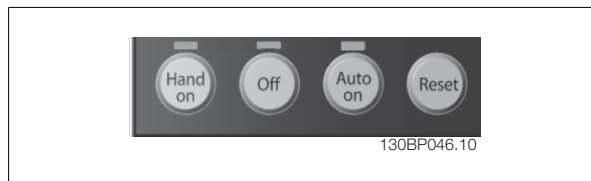

[Hand on] enables control of the adjustable frequency drive via the LCP. [Hand on] also starts the motor and it is now possible to enter the motor speed data by means of the arrow keys. The key can be selected as Enable [1] og Disable [0] via par. 0-40 *[Hand on] Key on LCP*.

External stop signals activated by means of control signals or a serial bus will override a 'start' command via the LCP.

The following control signals will still be active when [Hand on] is activated:

- [Hand on] - [Off] - [Auto on]
- Reset
- Coasting stop inverse
- Reversing
- Set-up select lsb - Set-up select msb
- Stop command from serial communication
- Quick stop
- DC brake

[Off] stops the connected motor. The key can be selected as Enable [1] or Disable [0] via par. 0-41 *[Off] Key on LCP*.
 If no external stop function is selected and the [Off] key is inactive, the motor can be stopped by disconnecting the voltage.

[Auto on] enables the adjustable frequency drive to be controlled via the control terminals and/or serial communication. When a start signal is applied on the control terminals and/or the bus, the adjustable frequency drive will start. The key can be selected as Enable [1] or Disable [0] via par. 0-42 *[Auto on] Key on LCP*.

NOTE!
 An active HAND-OFF-AUTO signal via the digital inputs has higher priority than the control keys [Hand on] [Auto on].

[Reset] is used for resetting the adjustable frequency drive after an alarm (trip). It can be selected as Enable [1] or Disable [0] via par. 0-43 *[Reset] Key on LCP*.

2.1.19 Initialization to Default Settings

Initialize the adjustable frequency drive to default settings in two ways:

Recommended initialization (via par. 14-22 *Operation Mode*)

1. Select par. 14-22 *Operation Mode*
 2. Press [OK]
 3. Select "Initialization"
 4. Press [OK]
 5. Cut off the line power supply and wait until the display turns off.
 6. Reconnect the line power supply - the adjustable frequency drive is now reset.

- Par. 14-22 *Operation Mode* initializes all except:

 - Par. 14-50 *RFI 1*
 - Par. 8-30 *Protocol*
 - Par. 8-31 *Address*
 - Par. 8-32 *FC Port Baud Rate*
 - Par. 8-35 *Minimum Response Delay*
 - Par. 8-36 *Max Response Delay*
 - Par. 8-37 *Max Inter-Char Delay*
 - Par. 15-00 *Operating Hours* to par. 15-05 *Over Volts*
 - Par. 15-20 *Historic Log: Event* to par. 15-22 *Historic Log: Time*
 - Par. 15-30 *Fault Log: Error Code* to par. 15-32 *Alarm Log: Time*

Manual initialization

1. Disconnect from the line power and wait until the display turns off.
 - 2a. Press [Status] - [Main Menu] - [OK] at the same time during power-up for LCP 102, Graphical Display
 - 2b. Press [Menu] while powering up for LCP 101, Numerical Display
 3. Release the keys after 5 s.
 4. The adjustable frequency drive is now programmed according to default settings.

- This procedure initializes all except:

 - Par. 15-00 *Operating Hours*
 - Par. 15-03 *Power-ups*
 - Par. 15-04 *Over Temps*
 - Par. 15-05 *Over Volts*

NOTE!
 When you carry out manual initialization, you also reset serial communication, RFI filter settings (par. 14-50 *RFI 1*) and fault log settings.

2

3 Parameter descriptions

3.1 Parameter Selection

Parameters for FC 300 are grouped into various parameter groups for easy selection of the correct parameters for optimized operation of the adjustable frequency drive.

0-xx Operation and display parameters

- Basic settings, set-up handling
- Display and Local Control Panel parameters for choosing readouts, setting up selections and copying functions

1-xx Load and motor parameters, including all load- and motor-related parameters

2-xx Brake parameters

- DC brake
- Dynamic brake (resistor brake)
- Mechanical brake
- Overvoltage Control

3-xx References and ramping parameters includes DigiPot function

4-xx Limits and warnings; setting of limits and warning parameters

5-xx Digital inputs and outputs, including relay controls

6-xx Analog inputs and outputs

7-xx Controls; setting parameters for speed and process control

8-xx Communication and option parameters for setting of FC RS 485 and FC USB port parameters.

9-xx Profibus parameters

10-xx DeviceNet and CAN serial communication bus parameters

13-xx Smart Logic Control parameters

14-xx Special function parameters

15-xx Drive information parameters

16-xx Readout parameters

17-xx Encoder option parameters

18-xx Readout 2 parameters

30-xx Special Features

3.2 Parameters: Operation and Display

3.2.1 0-** Operation / Display

Parameters related to the fundamental functions of the adjustable frequency drive, function of the LCP buttons and configuration of the LCP display.

3.2.2 0-0* Basic Settings

Parameter group for basic adjustable frequency drive settings.

0-01 Language

Option:	Function:
	Defines the language to be used in the display. The adjustable frequency drive can be delivered with 4 different language packages. English and German are included in all packages. English cannot be erased or manipulated.
[0] * English	Part of Language packages 1 - 4
[1] Deutsch	Part of Language packages 1 - 4
[2] Francais	Part of Language package 1
[3] Dansk	Part of Language package 1
[4] Spanish	Part of Language package 1
[5] Italiano	Part of Language package 1
Svenska	Part of Language package 1
[7] Nederlands	Part of Language package 1
Chinese	Part of Language package 2
Suomi	Part of Language package 1
English US	Part of Language package 4
Greek	Part of Language package 4
Bras.port	Part of Language package 4
Slovenian	Part of Language package 3
Korean	Part of Language package 2
Japanese	Part of Language package 2
Turkish	Part of Language package 4
Trad.Chinese	Part of Language package 2
Bulgarian	Part of Language package 3
Srpski	Part of Language package 3
Romanian	Part of Language package 3
Magyar	Part of Language package 3
Czech	Part of Language package 3

Polski	Part of Language package 4
Russian	Part of Language package 3
Thai	Part of Language package 2
Bahasa Indonesia	Part of Language package 2
[99]	Unknown

0-02 Motor Speed Unit

Option:	Function:
	<p>This parameter cannot be adjusted while the motor is running.</p> <p>The display showing depends on settings in par. 0-02 <i>Motor Speed Unit</i> and par. 0-03 <i>Regional Settings</i>. The default setting of par. 0-02 <i>Motor Speed Unit</i> and par. 0-03 <i>Regional Settings</i> depends on which region of the world the adjustable frequency drive is supplied to, but can be re-programmed as required.</p>
	<div style="border: 1px solid black; padding: 5px;">  <p>NOTE! Changing the <i>Motor Speed Unit</i> will reset certain parameters to their initial value. It is recommended to select the motor speed unit first before modifying other parameters.</p> </div>

[0]	RPM	Selects display of motor speed variables and parameters (i.e. references, feedbacks and limits) in terms of motor speed (RPM).
[1] *	Hz	Selects display of motor speed variables and parameters (i.e., references, feedbacks and limits) in terms of output frequency to the motor (Hz).

0-03 Regional Settings

Option:	Function:	
[0] *	International	Activates par. 1-20 <i>Motor Power [kW]</i> for setting the motor power in kW and sets the default value of par. 1-23 <i>Motor Frequency</i> to 50 Hz.
[1]	US	Activates par. 1-20 <i>Motor Power [kW]</i> for setting the motor power in HP and sets the default value of par. 1-23 <i>Motor Frequency</i> to 60 Hz.

This parameter cannot be adjusted while the motor is running.

0-04 Operating State at Power-up (Hand)

Option:	Function:	
	Selects the operating mode upon reconnection of the adjustable frequency drive to AC line voltage after power-down in hand (local) operation mode.	
[0]	Resume	Restarts the adjustable frequency drive maintaining the same local reference and the same start/stop settings (applied by [HAND ON/OFF]) as before the adjustable frequency drive was powered down.
[1] *	Forced stop, ref=old	Restarts the adjustable frequency drive with a saved local reference, after AC line voltage reappears and after pressing [HAND ON].
[2]	Forced stop, ref=0	Resets the local reference to 0 upon restarting the adjustable frequency drive.

3.2.3 0-1* Set-up Operations

Define and control the individual parameter set-ups.

The adjustable frequency drive has four parameter set-ups that can be programmed independently of each other. This makes the adjustable frequency drive very flexible and able to solve advanced control functionality problems, often eliminating external control equipment costs. For example, these can be used to program the adjustable frequency drive to operate according to one control scheme in one set-up (e.g., motor 1 for horizontal movement), and another control scheme in another set-up (e.g., motor 2 for vertical movement). Alternatively, they can be used by an OEM machine builder to identically program all their factory-fitted adjustable frequency drives for different machine types within a range in order to have the same parameters; and then, during production/commissioning, to simply select a specific set-up, depending on in which machine the adjustable frequency drive is installed. The active set-up (i.e., the set-up in which the adjustable frequency drive is currently operating) can be selected in par. 0-10 *Active Set-up* and is displayed in the LCP. Using Multi set-up, it is possible to switch between set-ups with the adjustable frequency drive running or stopped via digital input or serial communication commands. If it is necessary to change set-ups while running, ensure par. 0-12 *This Set-up Linked to* is programmed as required. Using par. 0-11 *Edit Set-up*, it is possible to edit parameters in any of the set-ups during adjustable frequency drive operation in its active set-up; this set-up can be different than the one being edited. Using par. 0-51 *Set-up Copy*, it is possible to copy parameter settings between the set-ups to enable quicker commissioning if similar parameter settings are required in different set-ups.

0-10 Active Set-up

Option:	Function:
	Select the set-up to control the adjustable frequency drive functions.
[0] Factory setup	Cannot be changed. It contains the Danfoss data set, and can be used as a data source when returning the other set-ups to a known state.
[1] * Set-up 1	<i>Set-up 1</i> [1] to <i>Set-up 4</i> [4] are the four separate parameter set-ups within which all parameters can be programmed.
[2] Set-up 2	
[3] Set-up 3	
[4] Set-up 4	
[9] Multi setup	Remote selection of set-ups using digital inputs and the serial communication port. This set-up uses the settings from par. 0-12 <i>This Set-up Linked to</i> . Stop the adjustable frequency drive before making changes to open-loop and closed-loop functions.

Use par. 0-51 *Set-up Copy* to copy a set-up to one or all other set-ups. Stop the adjustable frequency drive before switching between set-ups, where parameters marked 'not changeable during operation' have different values. To avoid conflicting settings of the same parameter within two different set-ups, link the set-ups together using par. 0-12 *This Set-up Linked to*. Parameters which are 'not changeable during operation' are marked FALSE in the parameter lists in the section *Parameter Lists*.

0-11 Edit Set-up

Option:	Function:
	Select the set-up to be edited (i.e., programmed) during operation; either the active set-up or one of the inactive set-ups.
[0] Factory setup	Cannot be edited, but it is useful as a data source for returning the other set-ups to a known state.
[1] * Set-up 1	<i>Set-up 1</i> [1] to <i>Set-up 4</i> [4] can be edited freely during operation, independently of the active set-up.
[2] Set-up 2	
[3] Set-up 3	
[4] Set-up 4	
[9] Active Set-up	Can also be edited during operation. Edit the chosen set-up from a range of sources: LCP, FC RS 485, FC USB or up to five serial communication bus sites.

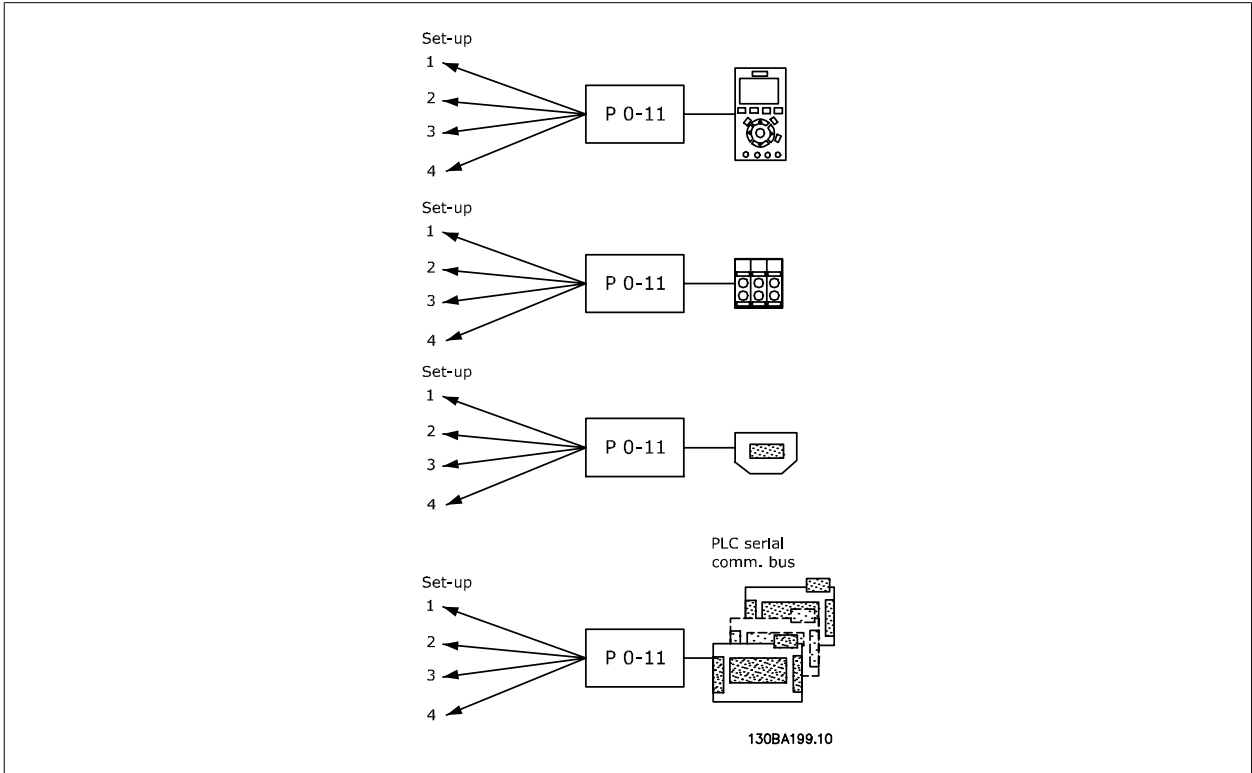

0-12 This Set-up Linked to

Option:

Function:

To enable conflict-free changes from one set-up to another during operation, link set-ups containing parameters that are not changeable during operation. The link will ensure the proper synchronization of the 'not changeable during operation' parameter values when moving from one set-up to another during operation. 'Not changeable during operation' parameters can be identified by the label FALSE in the parameter lists in the section *Parameter Lists*.

Par. 0-12 *This Set-up Linked to* is used by Multi set-up in par. 0-10 *Active Set-up*. Multi set-up is used to move from one set-up to another during operation (i.e., while the motor is running).

Example:

Use Multi set-up to shift from Set-up 1 to Set-up 2 while the motor is running. Program in Set-up 1 first, then ensure that Set-up 1 and Set-up 2 are synchronized (or 'linked'). Synchronization can be performed in two ways:

1. Change the edit set-up to *Set-up 2* [2] in par. 0-11 *Edit Set-up* and set par. 0-12 *This Set-up Linked to* to *Set-up 1* [1]. This will start the linking (synchronizing) process.

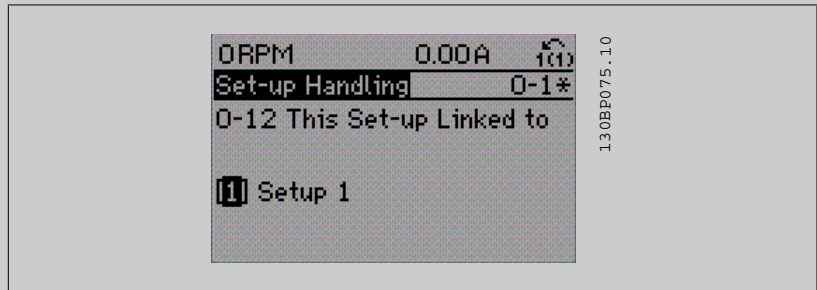

OR

2. While still in Set-up 1, copy Set-up 1 to Set-up 2. Then set par. 0-12 *This Set-up Linked to Set-up 2* [2]. This will start the linking process.

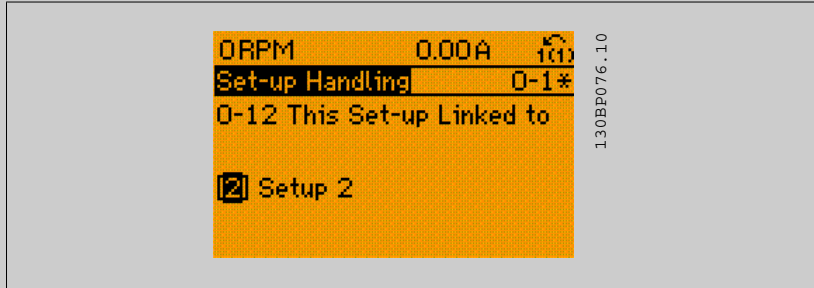

After the link is complete, par. 0-13 *Readout: Linked Set-ups* will read {1,2} to indicate that all 'not changeable during operation' parameters are now the same in Set-up 1 and Set-up 2. If there are changes to a "not changeable during operation" parameter, e.g., par. 1-30 *Stator Resistance (Rs)* in Set-up 2, they will also be changed automatically in Set-up 1. A switch between Set-up 1 and Set-up 2 during operation is now possible.

- [0] * Not linked
- [1] Set-up 1
- [2] Set-up 2
- [3] Set-up 3
- [4] Set-up 4

0-13 Readout: Linked Set-ups

Array [5]

Range:

0 N/A* [0 - 255 N/A]

Function:

View a list of all the set-ups linked by means of par. 0-12 *This Set-up Linked to*. The parameter has one index for each parameter set-up. The parameter value displayed for each index represents which set-ups are linked to that parameter set-up.

Index	LCP value
0	{0}
1	{1,2}
2	{1,2}
3	{3}
4	{4}

Table 3.2: Example: Set-up 1 and Set-up 2 are linked

0-14 Readout: Edit Set-ups / Channel

Range:

0* [-2147483648 - 2147483647]

Function:

View the setting of par. 0-11 *Edit Set-up* for each of the four different communication channels. When the number is displayed in hex, as it is in the LCP, each number represents one channel. Numbers 1-4 represent a set-up number; 'F' means factory setting; and 'A' means active set-up. The channels are, from right to left: LCP, FCbus, USB, HPFB1-5. Example: The number AAAAAA21h means that the FC bus selected Set-up 2 in par. 0-11 *Edit Set-up*, the LCP selected Set-up 1 and all others used the active set-up.

3.2.4 0-2* LCP Display

Define the variables displayed in the Graphical Local Control Panel.



NOTE!
Refer to par. 0-37 *Display Text 1*, par. 0-38 *Display Text 2* and par. 0-39 *Display Text 3* for information on how to write display texts.

0-20 Display Line 1.1 Small

Option:	Function:
	Select a variable for display in line 1, left position.
[0] None	No display value selected.
[953] Profibus Warning Word	
[1005] Readout Transmit Error Counter	
[1006] Readout Receive Error Counter	
[1007] Readout Bus Off Counter	
[1013] Warning Parameter	
[1230] Warning Parameter	
[1472] VLT Alarm Word	
[1473] VLT Warning Word	
[1474] VLT Ext. Status Word	
[1501] Running Hours	
[1502] kWh Counter	
[1600] Control Word	Present control word
[1601] Reference [Unit]	Total reference (sum of digital/analog/preset/bus/freeze ref./catch up and slow-down) in selected unit.
[1602] Reference %	Total reference (sum of digital/analog/preset/bus/freeze ref./catch up and slow-down) in percent.
[1603] Status Word	Present status word.
[1605] Main Actual Value [%]	Actual value as a percentage.
[1609] Custom Readout	
[1610] Power [kW]	Actual power consumed by the motor in kW.
[1611] Power [hp]	Actual power consumed by the motor in HP.
[1612] Motor voltage	Voltage supplied to the motor.
[1613] Frequency	Motor frequency, i.e., the output frequency from the adjustable frequency drive in Hz.
[1614] Motor Current	Phase current of the motor measured as effective value.
[1615] Frequency [%]	Motor frequency, i.e., the output frequency from the adjustable frequency drive in percent.
[1616] Torque [Nm]	Actual motor torque in Nm
[1617] * Speed [RPM]	Speed in RPM (revolutions per minute), i.e., the motor shaft speed in closed-loop.
[1618] Motor Thermal	Thermal load on the motor, calculated by the ETR function.
[1619] KTY sensor temperature	

[1620]	Motor Angle	
[1622]	Torque [%]	Present motor load as a percentage of the rated motor torque.
[1625]	Torque [Nm] High	
[1630]	DC Link Voltage	Intermediate circuit voltage in the adjustable frequency drive.
[1632]	Brake Energy /s	Present braking energy transferred to an external brake resistor. Stated as an instantaneous value.
[1633]	Brake Energy /2 min	Braking energy transferred to an external brake resistor. The mean power is calculated continuously for the most recent 120 seconds.
[1634]	Heatsink Temp.	Present heatsink temperature of the adjustable frequency drive. The cut-out limit is 203° ± 9°F [95° ± 5°C]; cutting back in occurs at 158° ± 9°F [70° ± 5°C].
[1635]	Inverter Thermal	Percentage load of the inverters.
[1636]	Inv. Nom. Current	Nominal current of the adjustable frequency drive.
[1637]	Inv. Max. Current	Maximum current of the adjustable frequency drive.
[1638]	SL Controller State	State of the event executed by the control.
[1639]	Control Card Temp.	Temperature of the control card.
[1650]	External Reference	Sum of the external reference as a percentage, i.e., the sum of analog/pulse/bus.
[1651]	Pulse Reference	Frequency in Hz connected to the digital inputs (18, 19 or 32, 33).
[1652]	Feedback [Unit]	Reference value from programmed digital input(s).
[1653]	Digi Pot Reference	
[1660]	Digital Input	Signal states form the 6 digital terminals (18, 19, 27, 29, 32 and 33). Input 18 corresponds to the bit at the far left. Signal low = 0; Signal high = 1.
[1661]	Terminal 53 Switch Setting	Setting of input terminal 54. Current = 0; Voltage = 1.
[1662]	Analog Input 53	Actual value at input 53 either as a reference or protection value.
[1663]	Terminal 54 Switch Setting	Setting of input terminal 54. Current = 0; Voltage = 1.
[1664]	Analog Input 54	Actual value at input 54 either as reference or protection value.
[1665]	Analog Output 42 [mA]	Actual value at output 42 in mA. Use par. 6-50 <i>Terminal 42 Output</i> to select the value to be shown.
[1666]	Digital Output [bin]	Binary value of all digital outputs.
[1667]	Freq. Input #29 [Hz]	Actual value of the frequency applied at terminal 29 as an impulse input.
[1668]	Freq. Input #33 [Hz]	Actual value of the frequency applied at terminal 33 as an impulse input.
[1669]	Pulse Output #27 [Hz]	Actual value of impulses applied to terminal 27 in digital output mode.
[1670]	Pulse Output #29 [Hz]	Actual value of impulses applied to terminal 29 in digital output mode.
[1671]	Relay Output [bin]	
[1672]	Counter A	Application dependent (e.g., SLC Control)
[1673]	Counter B	Application dependent (e.g., SLC Control)
[1674]	Prec. Stop Counter	Display the actual counter value.
[1675]	Analog In X30/11	Actual value at input X30/11 either as reference or protection value.
[1676]	Analog In X30/12	Actual value at input X30/12 either as reference or protection value.

[1677]	Analog Out X30/8 [mA]	Actual value at output X30/8 in mA. Use par. 6-60 <i>Terminal X30/8 Output</i> to select the value to be shown.
[1678]	Analog Out X45/1 [mA]	
[1679]	Analog Out X45/3 [mA]	
[1680]	Fieldbus CTW 1	Control word (CTW) received from the bus master.
[1682]	Fieldbus REF 1	Main reference value sent with control word from the bus master.
[1684]	Comm. Option Status	Extended serial communication option status word.
[1685]	FC Port CTW 1	Control word (CTW) received from the bus master.
[1686]	FC Port REF 1	Status word (STW) sent to the bus master.
[1690]	Alarm Word	One or more alarms in a Hex code.
[1691]	Alarm word 2	One or more alarms in a Hex code.
[1692]	Warning Word	One or more warnings in a Hex code.
[1693]	Warning word 2	One or more warnings in a Hex code.
[1694]	Ext. Status Word	One or more status conditions in a Hex code.
[1890]	Process PID Error	
[1891]	Process PID Output	
[1892]	Process PID Clamped Output	
[1893]	Process PID Gain Scaled Output	
[3019]	Wobble Delta Freq. Scaled	
[3401]	PCD 1 Write to MCO	
[3402]	PCD 2 Write to MCO	
[3403]	PCD 3 Write to MCO	
[3404]	PCD 4 Write to MCO	
[3405]	PCD 5 Write to MCO	
[3406]	PCD 6 Write to MCO	
[3407]	PCD 7 Write to MCO	
[3408]	PCD 8 Write to MCO	
[3409]	PCD 9 Write to MCO	
[3410]	PCD 10 Write to MCO	
[3421]	PCD 1 Read from MCO	
[3422]	PCD 2 Read from MCO	
[3423]	PCD 3 Read from MCO	
[3424]	PCD 4 Read from MCO	
[3425]	PCD 5 Read from MCO	
[3426]	PCD 6 Read from MCO	
[3427]	PCD 7 Read from MCO	
[3428]	PCD 8 Read from MCO	
[3429]	PCD 9 Read from MCO	
[3430]	PCD 10 Read from MCO	
[3440]	Digital Inputs	
[3441]	Digital Outputs	

[3450]	Actual Position
[3451]	Commanded Position
[3452]	Actual Master Position
[3453]	Slave Index Position
[3454]	Master Index Position
[3455]	Curve Position
[3456]	Track Error
[3457]	Synchronizing Error
[3458]	Actual Velocity
[3459]	Actual Master Velocity
[3460]	Synchronizing Status
[3461]	Axis Status
[3462]	Program Status
[3464]	MCO 302 Status
[3465]	MCO 302 Control
[3470]	MCO Alarm Word 1
[3471]	MCO Alarm Word 2
[9913]	Idle time
[9914]	Paramdb requests in queue
[9920]	HS Temp. (PC1)
[9921]	HS Temp. (PC2)
[9922]	HS Temp. (PC3)
[9923]	HS Temp. (PC4)
[9924]	HS Temp. (PC5)
[9925]	HS Temp. (PC6)
[9926]	HS Temp. (PC7)
[9927]	HS Temp. (PC8)

0-21 Display Line 1.2 Small

Option:

[1614] * Motor Current

Function:

Select a variable for display in line 1, middle position. The options are the same as listed for par. 0-20.

0-22 Display Line 1.3 Small

Option:

[1610] * Power [kW]

Function:

Select a variable for display in line 1, right position. The options are the same as listed for par. 0-20.

0-23 Display Line 2 Large

Option:

[1613] * Frequency

Function:

Select a variable for display in line 2. The options are the same as listed for par. 0-20.

0-24 Display Line 3 Large

Select a variable for display in line 3.

Option:

Function:

[1502] * kWh Counter

The options are the same as listed for par. 0-20 *Display Line 1.1 Small*.

0-25 My Personal Menu

Range:

Function:

Application [0 - 9999]
dependent*

3.2.5 0-3*LCP Custom Readout

It is possible to customize the display elements for various purposes: *Custom Readout. Value proportional to speed (linear, squared or cubed depending on unit selected in par. 0-30 *Custom Readout Unit*) *Display Text. Text string stored in a parameter.

Custom Readout

The calculated value to be displayed is based on settings in par. 0-30 *Custom Readout Unit*, par. 0-31 *Custom Readout Min Value* (linear only), par. 0-32 *Custom Readout Max Value*, par. 4-13 *Motor Speed High Limit [RPM]*, par. 4-14 *Motor Speed High Limit [Hz]* and actual speed.

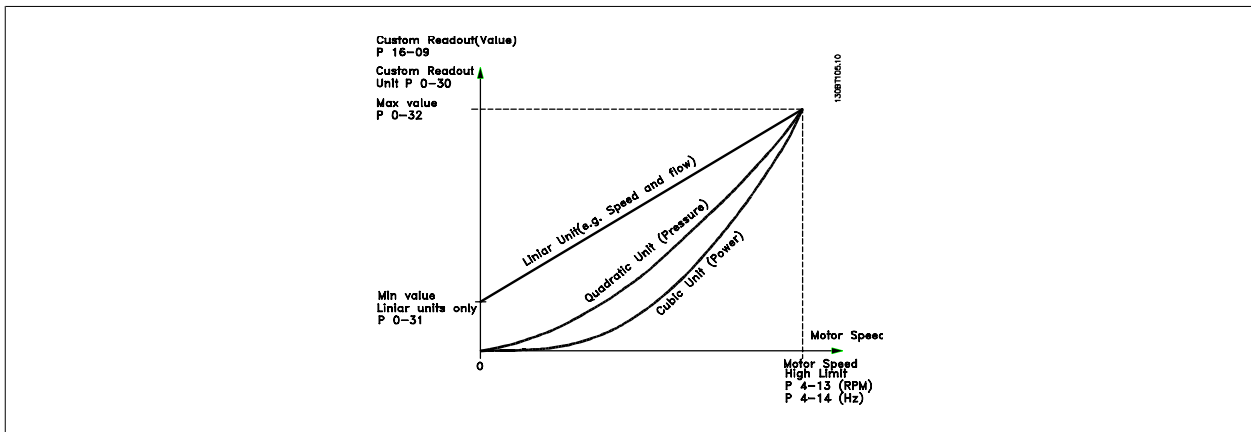

The relation will depend on the type of unit selected in par. 0-30 *Custom Readout Unit*.

Unit Type	Speed Relation
Dimensionless	Linear
Speed	
Flow, volume	
Flow, mass	
Velocity	
Length	
Temperature	
Pressure	Quadratic
Power	Cubic

0-30 Unit for User-defined Readout**Option:****Function:**

It is possible to program a value to be shown in the display of the LCP. The value will have a linear, squared or cubed relation to speed. This relation will depend on the unit selected (see table above). The actual calculated value can be read in par. 16-09 *Custom Readout*, and/or shown in the display by selecting Custom Readout [16-09] in par. 0-20 *Display Line 1.1 Small* to par. 0-24 *Display Line 3 Large*.

3

[0] *	None
[1]	%
[5]	PPM
[10]	min
[11]	RPM
[12]	PULSE/s
[20]	liter / sec.
[21]	liter / min
[22]	liter / hr.
[23]	m ³ / sec.
[24]	m ³ /min
[25]	m ³ / hr.
[30]	kg / sec.
[31]	kg/min
[32]	kg / hr.
[33]	ton / min
[34]	ton / hr.
[40]	m / sec.
[41]	m/min
[45]	m
[60]	°C
[70]	mbar
[71]	bar
[72]	Pa
[73]	kPa
[74]	m WG
[80]	kW
[120]	GPM
[121]	gal / sec.
[122]	gal/min
[123]	gal / hr.
[124]	CFM
[125]	ft ³ /s
[126]	ft ³ /min
[127]	ft ³ /h
[130]	lbs / sec.
[131]	lbs / min.

[132]	lbs / hr.
[140]	ft/s
[141]	ft/min
[145]	ft
[160]	°F
[170]	psi
[171]	lb/in ²
[172]	in. wtr. gage
[173]	ft WG
[180]	HP

0-31 Min Value of User-defined Readout

Range:	Function:
0.00 Cus- [Application dependant] tomReadou- tUnit*	This parameter sets the min. value of the custom defined readout (occurs at zero speed). Only possible to set different from 0 is when selecting a linear unit in par. 0-30 <i>Unit for User-defined Readout</i> . For quadratic and cubic units, the minimum value will be 0.

0-32 Custom Readout Max Value

Range:	Function:
100.00 Cus- [Application dependant] tomReadou- tUnit*	This parameter sets the max value to be shown when the speed of the motor has reached the set value for par. 4-13 <i>Motor Speed High Limit [RPM]</i> or par. 4-14 <i>Motor Speed High Limit [Hz]</i> (depends on setting in par. 0-02 <i>Motor Speed Unit</i>).

3.2.6 LCP Keypad, 0-4*

Enable, disable and password-protect individual keys on the LCP.

0-40 [Hand on] Key on LCP

Option:	Function:
[0] Disabled	No function
[1] * Enabled	[Hand on] Key enabled
[2] Password	Avoid unauthorized start in hand mode. If par. 0-40 <i>[Hand on] Key on LCPs</i> included in the My Personal Menu, then define the password in par. 0-65 <i>Personal Menu Password</i> . Otherwise, define the password in par. 0-60 <i>Main Menu Password</i> .
[3]	
[4]	
[5]	
[6]	

0-41 [Off] Key on LCP

Option:	Function:
[0] * Disabled	Avoids accidental stop of the adjustable frequency drive.
[1] * Enabled	
[2] Password	Avoids unauthorized stop. If par. 0-41 <i>[Off] Key on LCP</i> is included in the quick menu, then define the password in par. 0-65 <i>Quick Menu Password</i> .
[3] Hand Off/On	

[4] Hand Off/On w. Passw.

0-42 [Auto on] Key on LCP

Option:

Function:

[0] * Disabled

avoids accidental start of the adjustable frequency drive in auto mode.

[1] * Enabled

[2] Password

Avoids unauthorized start in auto mode. If par. 0-42 [Auto on] Key on LCP is included in the quick menu, then define the password in par. 0-65 Quick Menu Password.

[3] Hand Off/On

[4] Hand Off/On w. Passw.

0-43 [Reset] Key on LCP

Option:

Function:

[0] * Disabled

Avoids accidental alarm reset.

[1] * Enabled

[2] Password

Avoids unauthorized resetting. If par. 0-43 [Reset] Key on LCP is included in the quick menu, then define the password in par. 0-65 Quick Menu Password.

[3] Hand Off/On

[4] Hand Off/On w. Passw.

3

3.2.7 0-5* Copy / Save

Copy parameter settings between set-ups and to/from the LCP.

0-50 LCP Copy

Option:

Function:

[0] * No copy

[1] All to LCP

Copies all parameters in all set-ups from the adjustable frequency drive memory to the LCP memory.

[2] All from LCP

Copies all parameters in all set-ups from the LCP memory to the adjustable frequency drive memory.

[3] Size indep. of LCP

Copy only the parameters that are independent of the motor size. The latter selection can be used to program several adjustable frequency drives with the same function without disturbing motor data.

[4] File from MCO to LCP

[5] File from LCP to MCO

This parameter cannot be adjusted while the motor is running.

0-51 Set-up Copy		
Option:		Function:
[0] *	No copy	No function
[1]	Copy to set-up 1	Copies all parameters in the present Programming Set-up (defined in par. 0-11 <i>Programming Set-up</i>) to Set-up 1.
[2]	Copy to set-up 2	Copies all parameters in the present Programming Set-up (defined in par. 0-11 <i>Programming Set-up</i>) to Set-up 2.
[3]	Copy to set-up 3	Copies all parameters in the present Programming Set-up (defined in par. 0-11 <i>Programming Set-up</i>) to Set-up 3.
[4]	Copy to set-up 4	Copies all parameters in the present Programming Set-up (defined in par. 0-11 <i>Programming Set-up</i>) to Set-up 4.
[9]	Copy to all	Copies the parameters in the present set-up over to each of the set-ups 1 to 4.

3.2.8 0-6* Password

Define password access to menus.

0-60 Main Menu Password		
Range:		Function:
100 N/A* [0 - 999 N/A]		Define the password for access to the main menu via the [Main Menu] key. If par. 0-61 <i>Access to Main Menu w/o Password</i> is set to <i>Full access</i> [0], this parameter will be ignored.

0-61 Access to Main Menu w/o Password		
Option:		Function:
[0] *	Full access	Disables password defined in par. 0-60 <i>Main Menu Password</i> .
[1]	Read-only	Prevent unauthorized editing of main menu parameters.
[2]	No access	Prevent unauthorized viewing and editing of main menu parameters.
[3]	Bus: Read only	Read-only functions for parameters on the serial communication bus and/or FC standard bus.
[4]	Bus: No access	No access to parameters is allowed via the serial communication bus and/or FC standard bus.
[5]	All: Read only	Read-only function for parameters on the LCP, serial communication bus or FC standard bus.
[6]	All: No access	No access from LCP, serial communication bus or FC standard bus is allowed.

If *Full access* [0] is selected then par. 0-60 *Main Menu Password*, par. 0-65 *Personal Menu Password* and par. 0-66 *Access to Personal Menu w/o Password* will be ignored.

0-65 Quick Menu Password		
Range:		Function:
200* [-9999 - 9999]		Define the password for access to the quick menu via the [Quick Menu] key. If par. 0-66 <i>Access to Quick Menu w/o Password</i> is set to <i>Full access</i> [0], this parameter will be ignored.

0-66 Access to Quick Menu w/o Password		
Option:		Function:
[0] *	Full access	Disables the password defined in par. 0-65 <i>Quick Menu Password</i> .
[1]	Read-only	Prevents unauthorized editing of quick menu parameters.

[2]	No access	Prevents unauthorized viewing and editing of quick menu parameters.
[3]	Bus: Read only	Read only functions for quick menu parameters on serial communication bus and/ or FC standard bus.
[4]	Bus: No access	No access to quick menu parameters is allowed via serial communication bus and/ or FC standard bus.
[5]	All: Read only	read only function for quick menu parameters on LCP, serial communication bus or FC standard bus.
[6]	All: No access	No access from LCP, serial communication bus or FC standard bus is allowed.

If par. 0-61 *Access to Main Menu w/o Password* is set to *Full access* [0], this parameter will be ignored.

0-67 Bus Password Access

Range:

0* [0 - 9999]

Function:

Writing to this parameter enables users to unlock the adjustable frequency drive from bus/ MCT10.

3.3 Parameters: Load and Motor

3.3.1 1-0* General Settings

Define whether the adjustable frequency drive operates in speed mode or torque mode, and whether the internal PID control should be active or not.

1-00 Configuration Mode

Option:
Function:

		Select the application control principle to be used when a remote reference (i.e., via analog input or serial communication bus) is active. A remote reference can only be active when par. 3-13 <i>Reference Site</i> is set to [0] or [1].
[0] *	Speed open loop	Enables speed control (without feedback signal from motor) with automatic slip compensation for almost constant speed at varying loads. Compensations are active but can be disabled in the Load/Motor par. group 1-0*.
[1]	Speed closed loop	Enables encoder feedback from motor. Obtain full holding torque at 0 RPM. For increased speed accuracy, provide a feedback signal and set the speed PID control.
[2]	Torque	Connects the encoder speed feedback signal to the encoder input. Only possible with "Flux with motor feedback" option, par. 1-01 <i>Motor Control Principle</i> .
[3]	Process	Enables the use of process control in the adjustable frequency drive. The process control parameters are set in par. groups 7-2* and 7-3*.
[4]	Torque open loop	Enables the use of torque open-loop in VVC+ mode (par. 1-01 <i>Motor Control Principle</i>). The torque PID parameters are set in par. group 7-1*.
[5]	Wobble	Enables the wobble functionality in par. 30-00 to 30-19.
[6]	Surface Winder	Enables the surface winder control specific parameters in parameter group 7-2* and 7-3*.
[7]	Extended PID Speed OL	Specific parameters in group 7-2* to 7-5*.
[8]	Extended PID Speed CL	Specific parameters in group 7-2* to 7-5*.

1-01 Motor Control Principle

Option:
Function:

Select which motor control principle to employ.

[0] * U/f special motor mode, for parallel connected motors in special motor applications. When U/f is selected the characteristic of the control principle can be edited in par. 1-55 *U/f Characteristic - U* and par. 1-56 *U/f Characteristic - F*.

[1] VVC+ Voltage vector control principle suitable for most applications. The main benefit of VVC^{plus} operation is that it uses a robust motor model.

[2] Flux sensorless Flux vector control without encoder feedback, for simple installation and robustness against sudden load changes.

[3] Flux w/ motor feedb very high accuracy speed and torque control, suitable for the most demanding applications.

The best shaft performance is normally achieved using either of the two flux vector control modes *Flux sensorless* [2] and *Flux with encoder feedback* [3].

This parameter cannot be adjusted while the motor is running.

1-02 Flux Motor Feedback Source

Option: **Function:**

Select the interface at which to receive feedback from the motor.

[0] Motor feedb. P1-02

[1] * 24V encoder A and B channel encoder, which can only be connected to the digital input terminals 32/33. Terminals 32/33 must be programmed to *No operation*.

[2] MCB 102 Encoder module option that can be configured in par. group 17-1*. This parameter appears in FC 302 only.

[3] MCB 103 Optional resolver interface module which can be configured in parameter group 17-5*.

[5] MCO Encoder 2 Encoder interface 2 of the optional programmable motion controller MCO 305.

[6] Analog input 53

[7] Analog input 54

[8] Frequency input 29

[9] Frequency input 33

This parameter cannot be adjusted while the motor is running.

1-03 Torque Characteristics

Option: **Function:**

Select the torque characteristic required. VT and AEO are both energy saving operations.

[0] * Constant torque Motor shaft output provides constant torque under variable speed control.

[1] Variable torque Motor shaft output provides variable torque under variable speed control. Set the variable torque level in par. 14-40 *VT Level*.

[2] Auto Energy Optim. Automatically optimizes energy consumption by minimizing magnetization and frequency via par. 14-41 *AEO Minimum Magnetization* and par. 14-42 *Minimum AEO Frequency*.

This parameter cannot be adjusted while the motor is running.

1-04 Overload Mode

Option:	Function:
[0] * High torque	Allows up to 160% over torque.
[1] Normal torque	For an oversized motor - allows up to 110% over torque.

This parameter cannot be adjusted while the motor is running.

1-05 Local Mode Configuration

Option:	Function:
	Select which application configuration mode (par. 1-00 <i>Configuration Mode</i>), i.e., the application control principle, to use when a Local (LCP) Reference is active. A local reference can be active only when par. 3-13 <i>Reference Site</i> is set to [0] or [2]. By default, the local reference is active in hand mode only.
[0] Speed open-loop	
[1] Speed closed-loop	
[2] * As mode par 1-00	

1-06 Clockwise Direction

This parameter defines the term "Clockwise" corresponding to the LCP direction arrow. Used for easy change of direction of shaft rotation without swapping motor wires. (Valid from SW version 5.84)

Option:	Function:
[0] * Normal	Motor shaft will turn in clockwise direction when adjustable frequency drive is connected U -> U; V -> V, and W -> W to motor.
[1] Inverse	Motor shaft will turn in counter clockwise direction when adjustable frequency drive is connected U -> U; V -> V, and W -> W to motor.

This parameter cannot be changed while the motor is running.

3.3.2 1-1* Motor selection

Parameter group for setting general motor data.

This parameter group cannot be adjusted while the motor is running.

1-10 Motor Construction

Option:	Function:
	Select the motor construction type.
[0] * Asynchron	For asynchronous motors.
[1] PM, non salient SPM	For permanent magnet (PM) motors. Note that PM motors are divided into two groups, with either surface mounted (non-salient) or interior (salient) magnets.

Motor construction can either be asynchronous or permanent magnet (PM) motor.

3.3.3 1-2* Motor Data

Parameter group 1-2* comprises input data from the nameplate on the connected motor. Parameters in parameter group 1-2* cannot be adjusted while the motor is running.

	<p>NOTE! Changing the value of these parameters affects the setting of other parameters.</p>
---	---

1-20 Motor Power [kW]

Range:	Function:
Application [Application dependant] dependent*	

1-21 Motor Power [HP]

Range:	Function:
Application [Application dependant] dependent*	

1-22 Motor Voltage

Range:	Function:
Application [Application dependant] dependent*	

1-23 Motor Frequency

Range:	Function:
Application [20 - 1000 Hz] dependent*	Min - Max motor frequency: 20–1000 Hz. Select the motor frequency value from the motor nameplate data. If a value different from 50 Hz or 60 Hz is selected, it is necessary to adapt the load independent settings in par. 1-50 <i>Motor Magnetization at Zero Speed</i> to par. 1-53 <i>Model Shift Frequency</i> . For 87 Hz operation with 230/400 V motors, set the nameplate data for 230 V/50 Hz. Adapt par. 4-13 <i>Motor Speed High Limit [RPM]</i> and par. 3-03 <i>Maximum Reference</i> to the 87 Hz application.

1-24 Motor Current

Range:	Function:
Application [Application dependant] dependent*	

1-25 Motor Nominal Speed

Range:	Function:
Application [10 - 60000 RPM] dependent*	Enter the nominal motor speed value from the motor nameplate data. The data are used for calculating motor compensations.

	<p>NOTE! Motor speed must always be lower than synchronous speed</p>
---	---

1-26 Motor Cont. Rated Torque

Range:

Application [0.1 - 10000.0 Nm]
dependent*

Function:

Enter the value from the motor nameplate data. The default value corresponds to the nominal rated output. This parameter is available when par. 1-10 *Motor Construction* is set to *PM, non salient SPM* [1], i.e., the parameter is valid for PM and non-salient SPM motors only.

1-29 Automatic Motor Adaptation (AMA)

Option:
Function:

The AMA function optimizes dynamic motor performance by automatically optimizing the advanced motor parameters (par. 1-30 *Stator Resistance (Rs)* to par. 1-35 *Main Reactance (Xh)*) at motor standstill.

Activate the AMA function by pressing [Hand on] after selecting [1] or [2]. See also the section *Automatic Motor Adaptation* in the Design Guide. After a normal sequence, the display will read: "Press [OK] to finish AMA". After pressing the [OK] key, the adjustable frequency drive is ready for operation.

This parameter cannot be adjusted while the motor is running.

[0] * Off

[1] Enable complete AMA

Performs AMA of the stator resistance R_s , the rotor resistance R_r , the stator leakage reactance X_1 , the rotor leakage reactance X_2 and the main reactance X_h . Do *not* select this option if an LC filter is used between the adjustable frequency drive and the motor.

FC 301: The Complete AMA does not include X_h measurement for FC 301. Instead, the X_h value is determined from the motor database. R_s is the best adjustment method (see *1-3* Adv. Motor Data*).

[2] Enable reduced AMA

Performs a reduced AMA of the stator resistance R_s in the system only.

Note:

- For the best adaptation of the adjustable frequency drive, run AMA on a cold motor.
- AMA cannot be performed while the motor is running.
- AMA cannot be performed on permanent magnet motors.

NOTE!

It is important to set motor par. 1-2* correctly, since these form part of the AMA algorithm. An AMA must be performed to achieve optimum dynamic motor performance. It may take up to 10 min, depending on the power rating of the motor.

NOTE!

Avoid generating external torque during AMA.

NOTE!

If one of the settings in par. 1-2* is changed, par. 1-30 *Stator Resistance (Rs)* to par. 1-39 *Motor Poles*, the advanced motor parameters, will return to default setting.

1-34 Rotor Leakage Reactance (X2)**Range:** **Function:**Application [Application dependant]
dependent***1-35 Main Reactance (Xh)****Range:** **Function:**Application [Application dependant]
dependent***1-36 Iron Loss Resistance (Rfe)****Range:** **Function:**Application [Application dependant]
dependent***1-37 d-axis Inductance (Ld)****Range:** **Function:**Application [Application dependant]
dependent***1-39 Motor Poles****Range:** **Function:**Application [2 - 100] Enter the number of motor poles.
dependent*

Poles	$\sim n_n$ @ 50 Hz	$\sim n_n$ @60 Hz
2	2700 - 2880	3250 - 3460
4	1350 - 1450	1625 - 1730
6	700 - 960	840 - 1153

The table shows the number of poles for normal speed ranges of various motor types. Define motors designed for other frequencies separately. The motor pole value is always an even number, because it refers to the total number of poles, not pairs of poles. The adjustable frequency drive creates the initial setting of par. 1-39 *Motor Poles* based on par. 1-23 *Motor Frequency* and par. 1-25 *Motor Nominal Speed*.

1-40 Back EMF at 1000 RPM**Range:** **Function:**Application [Application dependant]
dependent***1-41 Motor Angle Offset****Range:** **Function:**

0* [-32768 - 32767]

Enter the correct offset angle between the PM motor and the index position (single-turn) of the attached encoder or resolver. The value range of 0–32768 corresponds to 0–2 * pi (radians). To obtain the offset angle value: After starting the adjustable frequency drive, apply DC hold and enter the value of par. 16-20 *Motor Angle* into this parameter.

This parameter is only active when par. 1-10 *Motor Construction* is set to *PM, non-salient SPM*[1] (Permanent Magnet Motor).

3.3.5 1-5* Load Indep. Setting

Parameters for setting the load-independent motor settings.

1-50 Motor Magnetization at Zero Speed

Range:

100 %* [0 - 300 %]

Function:

Use this parameter along with par. 1-51 *Min Speed Normal Magnetizing [RPM]* to obtain a different thermal load on the motor when running at low speed.

Enter a value which is a percentage of the rated magnetizing current. If the setting is too low, the torque on the motor shaft may be reduced.

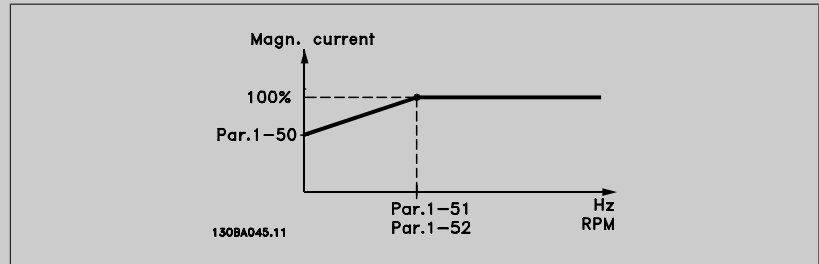

3

1-51 Min Speed Normal Magnetizing [RPM]

Range:

Application [10 - 300 RPM]
dependent*

Function:

1-52 Min Speed Normal Magnetizing [Hz]

Range:

Application [Application dependant]
dependent*

Function:

1-53 Model Shift Frequency

Range:

Application [Application dependant]
dependent*

Function:

1-54 Voltage reduction in fieldweakening

Range:

0 V* [0 - 100 V]

Function:

The value of this parameter will reduce the maximal voltage available for the flux of the motor in fieldweakening, giving more voltage available for torque. Be aware that a value that is too high may cause stalling problems at high speed.

1-55 U/f Characteristic - U

Range:

Application [0.0 - 1000.0 V]
dependent*

Function:

Enter the voltage at each frequency point to manually form a U/f characteristic matching the motor. The frequency points are defined in par. 1-56 *U/f Characteristic - F*. This parameter is an array parameter [0-5] and is only accessible when par. 1-01 *Motor Control Principle* is set to U/f[0].

3

1-56 U/f Characteristic - F

Range: Application [Application dependant] dependent*
Function:

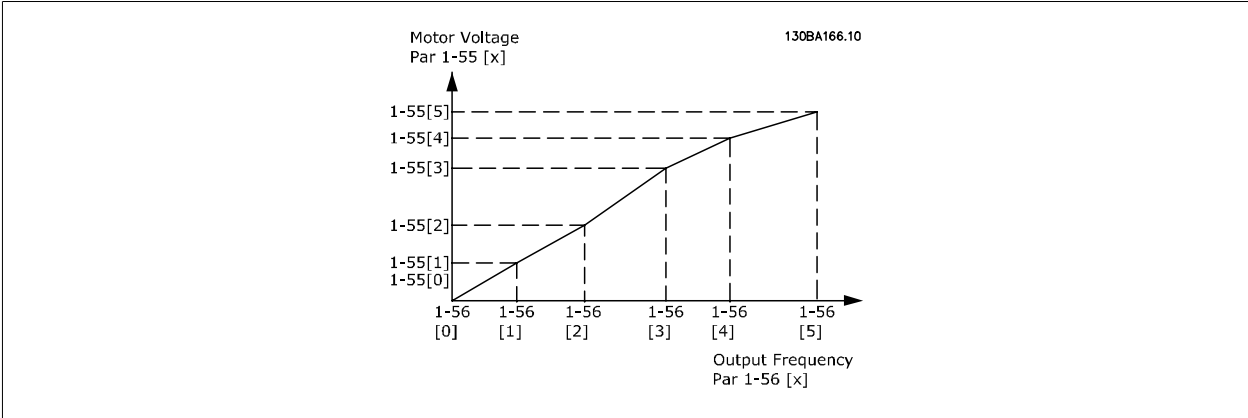

1-58 Flystart Test Pulses Current

Range: 100 %* [0 - 200 %]
Function: Control the percentage of the magnetizing current.

1-59 Flystart Test Pulses Frequency

Range: 100 %* [0 - 500 %]
Function: Control the percentage of the frequency of the test pulses.

3.3.6 1-6* Load Depend. Setting

Parameters for adjusting the load-dependent motor settings.

1-60 Low Speed Load Compensation

Range: 100 %* [0 - 300 %]
Function: Enter the % value to compensate voltage in relation to load while the motor is running at low speed, and obtain the optimum U/f characteristic. The motor size determines the frequency range within which this parameter is active.

Motor size 0.3–10 hp [0.25–7.5 kW]	Change-over < 10 Hz
---------------------------------------	------------------------

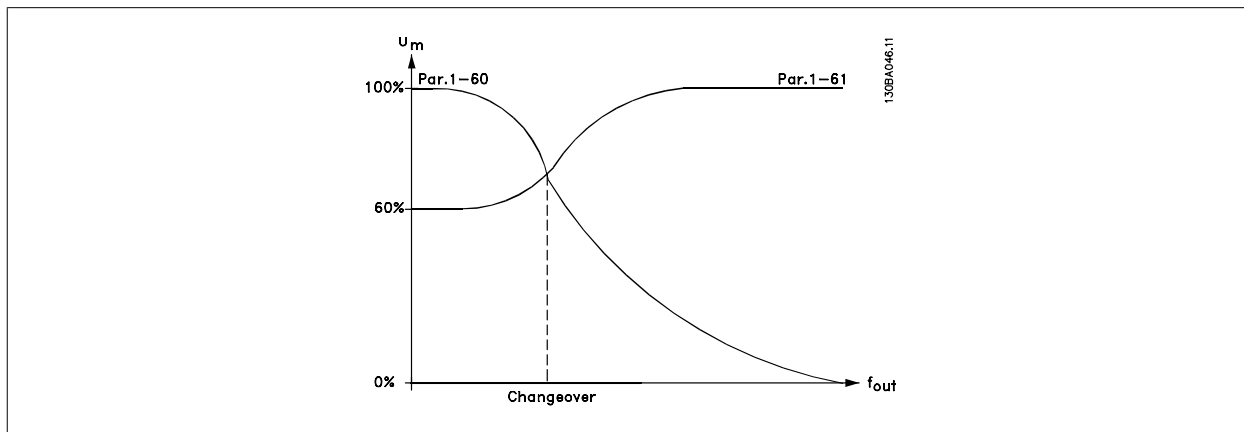

1-61 High Speed Load Compensation

Range:

100 %* [0 - 300 %]

Function:

Enter the % value to compensate voltage in relation to load while the motor is running at high speed, and obtain the optimum U/f characteristic. The motor size determines the frequency range within which this parameter is active.

Motor size
0.3–10 hp [0.25–7.5 kW]

Changeover
> 10 Hz

1-62 Slip Compensation

Range:

Application [-500 - 500 %]
dependent*

Function:

Enter the % value for slip compensation to compensate for tolerances in the value of $n_{m,N}$. Slip compensation is calculated automatically, i.e., on the basis of the rated motor speed $n_{m,N}$. This function is not active when par. 1-00 *Configuration Mode* is set to *Speed closed-loop* [1] or *Torque* [2] Torque control with speed feedback or when par. 1-01 *Motor Control Principle* is set to *U/f*[0] special motor mode.

1-63 Slip Compensation Time Constant

Range:

Application [0.05 - 5.00 s]
dependent*

Function:

1-64 Resonance Dampening

Range:

100 %* [0 - 500 %]

Function:

Enter the resonance dampening value. Set par. 1-64 *Resonance Dampening* and par. 1-65 *Resonance Dampening Time Constant* to help eliminate high-frequency resonance problems. To reduce resonance oscillation, increase the value of par. 1-64 *Resonance Dampening*.

1-65 Resonance Dampening Time Constant

Range:

5 ms* [5 - 50 ms]

Function:

Set par. 1-64 *Resonance Dampening* and par. 1-65 *Resonance Dampening Time Constant* to help eliminate high-frequency resonance problems. Enter the time constant that provides the best dampening.

1-66 Min. Current at Low Speed**Range:**

100 %* [Application dependant]

Function:

Enter the minimum motor current at low speed, see par. 1-53 *Model Shift Frequency*. Increasing this current improves motor torque at low speed.

Par. 1-66 *Min. Current at Low Speed* is enabled when par. 1-00 *Configuration Mode = Speed open-loop* [0] only. The adjustable frequency drive runs with constant current through motor for speeds below 10 Hz.

For speeds above 10 Hz, the motor flux model in the adjustable frequency drive controls the motor. par. 4-16 *Torque Limit Motor Mode* and / or par. 4-17 *Torque Limit Generator Mode* automatically adjust par. 1-66 *Min. Current at Low Speed*. The parameter with the highest value adjusts par. 1-66 *Min. Current at Low Speed*. The current setting in par. 1-66 *Min. Current at Low Speed* is composed of the torque generating current and the magnetizing current.

Example: Set par. 4-16 *Torque Limit Motor Mode* to 100% and set par. 4-17 *Torque Limit Generator Mode* to 60%. par. 1-66 *Min. Current at Low Speed* automatically adjusts to about 127%, depending on the motor size.

This parameter is available for the FC 302 only.

1-67 Load Type**Option:**

[0] * Passive load

Function:

For conveyers, fan and pump applications.

[1] Active load

For hoisting applications. When *Active Load* [1] is selected, set par. 1-66 *Min. Current at Low Speed* to a level which corresponds to maximum torque.

This parameter is available for the FC 302 only.

1-68 Minimum Inertia**Range:**Application [Application dependant]
dependent***Function:**

This parameter cannot be adjusted while motor is running.

1-69 Maximum Inertia**Range:**Application [Application dependant]
dependent***Function:**

This parameter cannot be adjusted while motor is running.

3.3.7 1-7* Start Adjustments

Parameters for setting special motor start features.

1-71 Start Delay**Range:**

0.0 s* [0.0 - 10.0 s]

Function:

This parameter refers to the start function selected in par. 1-72 *Start Function*. Enter the time delay required before commencing acceleration.

1-72 Start Function**Option:****Function:**

Select the start function during start delay. This parameter is linked to par. 1-71 *Start Delay*.

[0]	DC Hold/delay time	Energizes motor with a DC holding current (par. 2-00 <i>DC Hold Current</i>) during the start delay time.
[1]	DC Brake/delay time	Energizes motor with a DC braking current (par. 2-01 <i>DC Brake Current</i>) during the start delay time.
[2] *	Coast/delay time	Motor coasted during the start delay time (inverter off).
[3]	Start speed cw	Only possible with VVC+Advanced Vector Control. Connect the function described in par. 1-74 <i>Start Speed [RPM]</i> and par. 1-76 <i>Start Current</i> in the start delay time. Regardless of the value applied by the reference signal, the output speed applies the setting of the start speed in par. 1-74 <i>Start Speed [RPM]</i> or par. 1-75 <i>Start Speed [Hz]</i> and the output current corresponds to the setting of the start current in par. 1-76 <i>Start Current</i> . This function is typically used in hoisting applications without counterweight, and especially in applications with a cone motor where the start is clockwise, followed by rotation in the reference direction.
[4]	Horizontal operation	Only possible with VVC+Advanced Vector Control. For obtaining the function described in par. 1-74 <i>Start Speed [RPM]</i> and par. 1-76 <i>Start Current</i> during the start delay time. The motor rotates in the reference direction. If the reference signal equals zero (0), par. 1-74 <i>Start Speed [RPM]</i> is ignored and the output speed equals zero (0). The output current corresponds to the setting of the start current in par. 1-76 <i>Start Current</i> .
[5]	VVC+/Flux clockwise	for the function described in par. 1-74 <i>Start Speed [RPM]</i> only. The start current is calculated automatically. This function uses the start speed in the start delay time only. Regardless of the value set by the reference signal, the output speed equals the setting of the start speed in par. 1-74 <i>Start Speed [RPM]</i> . <i>Start speed/current clockwise</i> [3] and <i>VVCplus/Flux clockwise</i> [5] are typically used in hoisting applications. <i>Start speed/current in reference direction</i> [4] is particularly used in applications with counterweight and horizontal movement.
[6]	Hoist Mech. Brake Rel	For utilizing mechanical brake control functions, par. 2-24 <i>Stop Delay</i> to par. 2-28 <i>Gain Boost Factor</i> . This parameter is only active when par. 1-01 <i>Motor Control Principle</i> is set to [3] <i>Flux w/ motor feedback (FC 302 only)</i> .

1-73 Flying Start

Option:

Function:

This function makes it possible to catch a motor that is spinning freely due to a line drop-out.

[0] *	Disabled	No function
[1]	Enabled	Enables the adjustable frequency drive to "catch" and control a spinning motor. When par. 1-73 is enabled, par. 1-71 <i>Start Delay</i> and par. 1-72 <i>Start Function</i> have no function.
[2]	Enabled Always	

This parameter cannot be adjusted while motor is running.

NOTE!
This function is not recommended for hoisting applications.

1-74 Start Speed [RPM]

Range:

Function:

Application [0 - 600 RPM]
dependent*

Set a motor start speed. After the start signal, the output speed leaps to set value. Set the start function in par. 1-72 *Start Function* to [3], [4] or [5], and set a start delay time in par. 1-71 *Start Delay*.

1-75 Start Speed [Hz]

Range:

Application [Application dependant]
dependent*

Function:

1-76 Start Current

Range:

0.00 A* [Application dependant]

Function:

Some motors, e.g., cone rotor motors, need extra current/starting speed to disengage the rotor. To obtain this boost, set the required current in par. 1-76 *Start Current*. Set par. 1-74 *Start Speed [RPM]*. Set par. 1-72 *Start Function* to [3] or [4], and set a start delay time in par. 1-71 *Start Delay*.

This parameter can be used for hoist applications (cone rotor).

3.3.8 1-8* Stop Adjustments

Parameters for setting special stop features for the motor.

1-80 Function at Stop

Option:
Function:

Select the adjustable frequency drive function after a stop command or after the speed is ramped down to the settings in par. 1-81 *Min Speed for Function at Stop [RPM]*.

[0] * Coast Leaves motor in free mode. The motor is disconnected from the adjustable frequency drive.

[1] DC hold Energizes motor with a DC holding current (see par. 2-00 *DC Hold Current*).

[2] Motor check Checks if a motor has been connected.

[3] Pre-magnetizing Builds up a magnetic field while the motor is stopped. The motor can now produce a quick torque build-up at start. Asynchronous motors only.

[4] DC Voltage U0

1-81 Min Speed for Function at Stop [RPM]

Range:

Application [0 - 600 RPM]
dependent*

Function:

1-82 Min Speed for Function at Stop [Hz]

Range:

Application [Application dependant]
dependent*

Function:

1-83 Precise Stop Function

Option:
Function:

[0] * Precise ramp stop Achieves high repetitive precision at the stopping point.

[1] Cnt stop with reset Runs the adjustable frequency drive from receipt of a pulse start signal until the number of pulses programmed by the user in par. 1-84 *Precise Stop Counter Value* has been received at input terminal 29 or input terminal 33.
An internal stop signal will activate the normal ramp-down time (par. 3-42 *Ramp 1 Ramp-down Time*, par. 3-52 *Ramp 2 Ramp-down Time*, par. 3-62 *Ramp 3 Ramp-down Time* or par. 3-72 *Ramp 4 Ramp-down Time*). The counter function is activated (starts timing) at the edge of the start signal

(when it changes from stop to start). After each precise stop, the number of pulses counted during ramp-down 0 rpm is reset.

[2]	Cnt stop w/o reset	Same as [1] but the number of pulses counted during ramp-down to 0 rpm is deducted from the counter value in par. 1-84 <i>Precise Stop Counter Value</i> .
[3]	Speed comp stop	Stops at precisely the same point, regardless of the present speed, the stop signal is delayed internally when the present speed is lower than the maximum speed (set in par. 4-19 <i>Max Output Frequency</i>).
[4]	Com cnt stop w/rst	Same as [3], but after each precise stop the number of pulses counted during ramp-down 0 rpm is reset.
[5]	Comp cnt stop w/o r	Same as [3] but the number of pulses counted during ramp-down to 0 rpm is deducted from the counter value in par. 1-84 <i>Precise Stop Counter Value</i> .

This parameter cannot be adjusted while the motor is running.

1-84 Precise Stop Counter Value

Range:

100000* [0 - 999999999]

Function:

Enter the counter value to be used in the integrated precise stop function, par. 1-83 *Precise Stop Function*.
The maximum permissible frequency at terminal 29 or 33 is 110 kHz.

1-85 Precise Stop Speed Compensation Delay

Range:

10 ms* [0 - 100 ms]

Function:

Enter the delay time for sensors, PLCs, etc. for use in par. 1-83 *Precise Stop Function*. In speed compensated stop mode, the delay time at different frequencies has a major influence on the stop function.

3.3.9 1-9* Motor Temperature

Parameters for setting the temperature protection features for the motor.

1-90 Motor Thermal Protection

Option:

Function:

The adjustable frequency drive determines the motor temperature for motor protection in two different ways:

- Via a thermistor sensor connected to one of the analog or digital inputs (par. 1-93 *Thermistor Source*).
- Via calculation (ETR = Electronic Terminal Relay) of the thermal load, based on the actual load and time. The calculated thermal load is compared with the rated motor current $I_{M,N}$ and the rated motor frequency $f_{M,N}$. The calculations estimate the need for a lower load at lower speed due to less cooling from the fan incorporated in the motor.

[0] *	No protection	Continuously overloaded motor, when no warning or trip of the adjustable frequency drive is required.
[1]	Thermistor warning	Activates a warning when the connected thermistor or KTY sensor in the motor reacts in the event of motor overtemperature.
[2]	Thermistor trip	Stops (trips) adjustable frequency drive when connected thermistor in motor reacts in the event of motor overtemperature. The thermistor cut-out value must be > 3 kΩ.

Integrate a thermistor (PTC sensor) in the motor for winding protection.

[3]	ETR warning 1	Please see detailed description below
[4]	ETR trip 1	
[5]	ETR warning 2	
[6]	ETR trip 2	
[7]	ETR warning 3	
[8]	ETR trip 3	
[9]	ETR warning 4	
[10]	ETR trip 4	

3

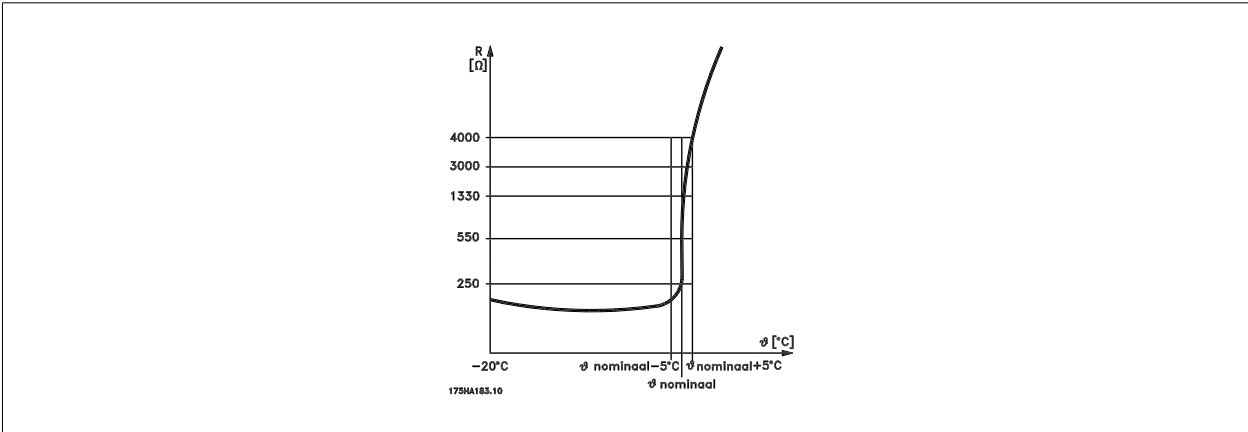

Motor protection can be implemented using a range of techniques: PTC or KTY sensor (see also section *KTY Sensor Connection*) in motor windings; mechanical thermal switch (Klixon type); or Electronic Thermal Relay (ETR).

Using a digital input and 24 V as power supply:

Example: The adjustable frequency drive trips when the motor temperature is too high

Parameter set-up:

Set par. 1-90 *Motor Thermal Protection to Thermistor Trip* [2]

Set par. 1-93 *Thermistor Source to Digital Input* [6]

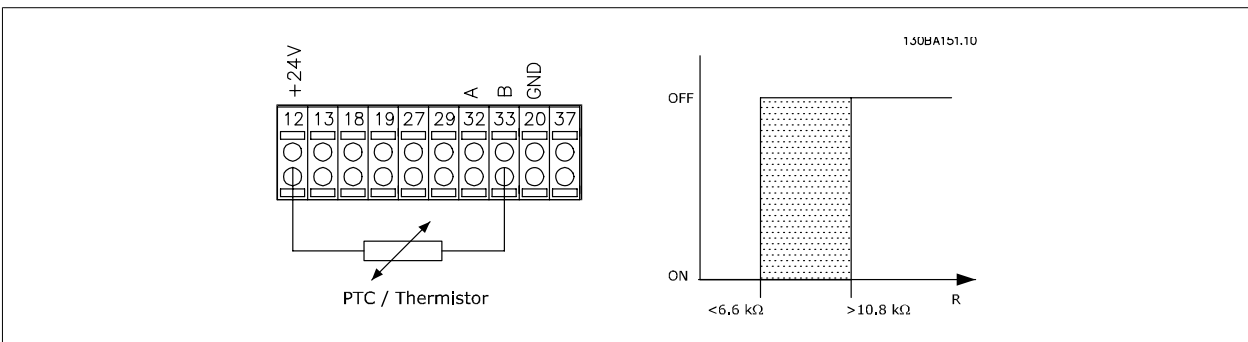

Using a digital input and 10 V as power supply:

Example: The adjustable frequency drive trips when the motor temperature is too high.

Parameter set-up:

Set par. 1-90 *Motor Thermal Protection* to *Thermistor Trip* [2]

Set par. 1-93 *Thermistor Source* to *Digital Input* [6]

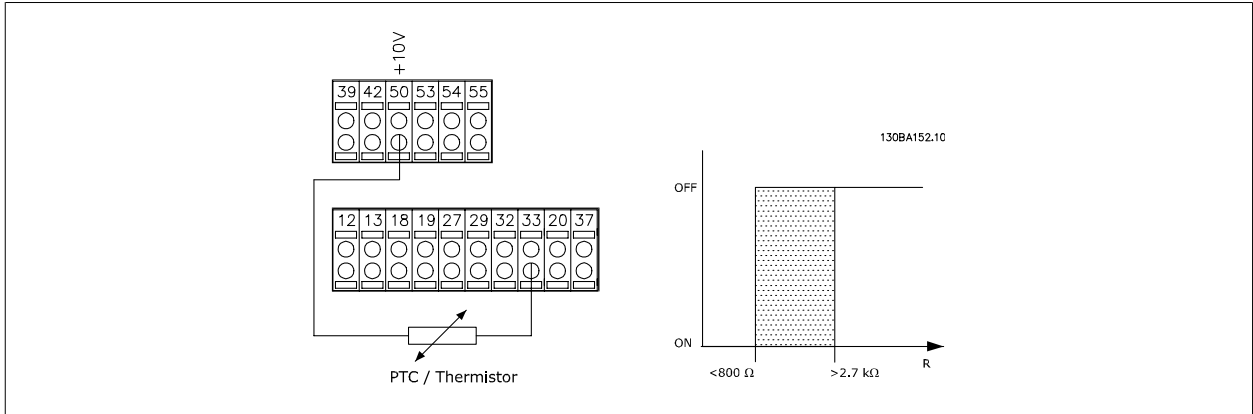

Using an analog input and 10 V as power supply:

Example: The adjustable frequency drive trips when the motor temperature is too high.

Parameter set-up:

Set par. 1-90 *Motor Thermal Protection* to *Thermistor Trip* [2]

Set par. 1-93 *Thermistor Source* to *Analog Input 54* [2]

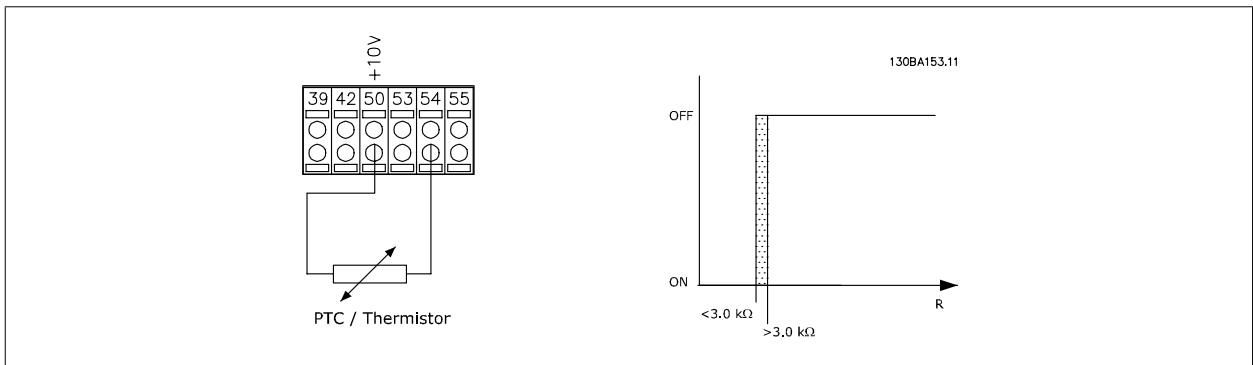

Input	Supply Voltage	Threshold
Digital/analog	Volt	Cut-out Values
Digital	24 V	< 6.6 kΩ - > 10.8 kΩ
Digital	10 V	< 800Ω - > 2.7 kΩ
Analog	10 V	< 3.0 kΩ - > 3.0 kΩ

NOTE! Ensure that the chosen supply voltage follows the specification of the thermistor element utilized.

Select *ETR Warning 1-4*, to activate a warning on the display when the motor is overloaded.

Select *ETR Trip 1-4* to trip the adjustable frequency drive when the motor is overloaded.

Program a warning signal via one of the digital outputs. The signal appears in the event of a warning and if the adjustable frequency drive trips (thermal warning).

ETR (Electronic Terminal Relay) functions 1-4 will calculate the load when the set-up where they were selected is active. For example, ETR starts calculating when set-up 3 is selected. For the North American market: The ETR functions provide class 20 motor overload protection in accordance with NEC.

3

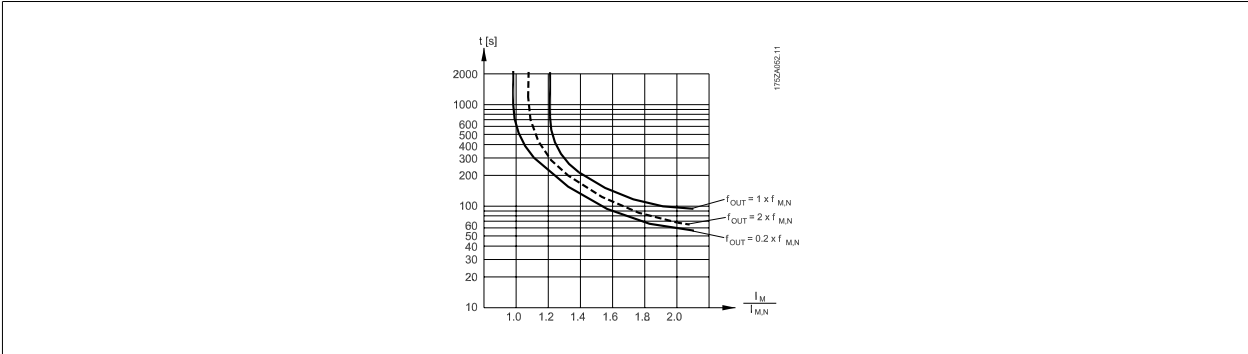

1-91 Motor External Fan

Option:	Function:
[0] * No	No external fan is required, i.e. the motor is derated at low speed.
[1] Yes	Applies an external motor fan (external ventilation), so that no derating of the motor is required at low speed. The graph below is followed if the motor current is lower than nominal motor current (see par. 1-24 <i>Motor Current</i>). If the motor current exceeds nominal current, the operation time still decreases as if no fan were installed.

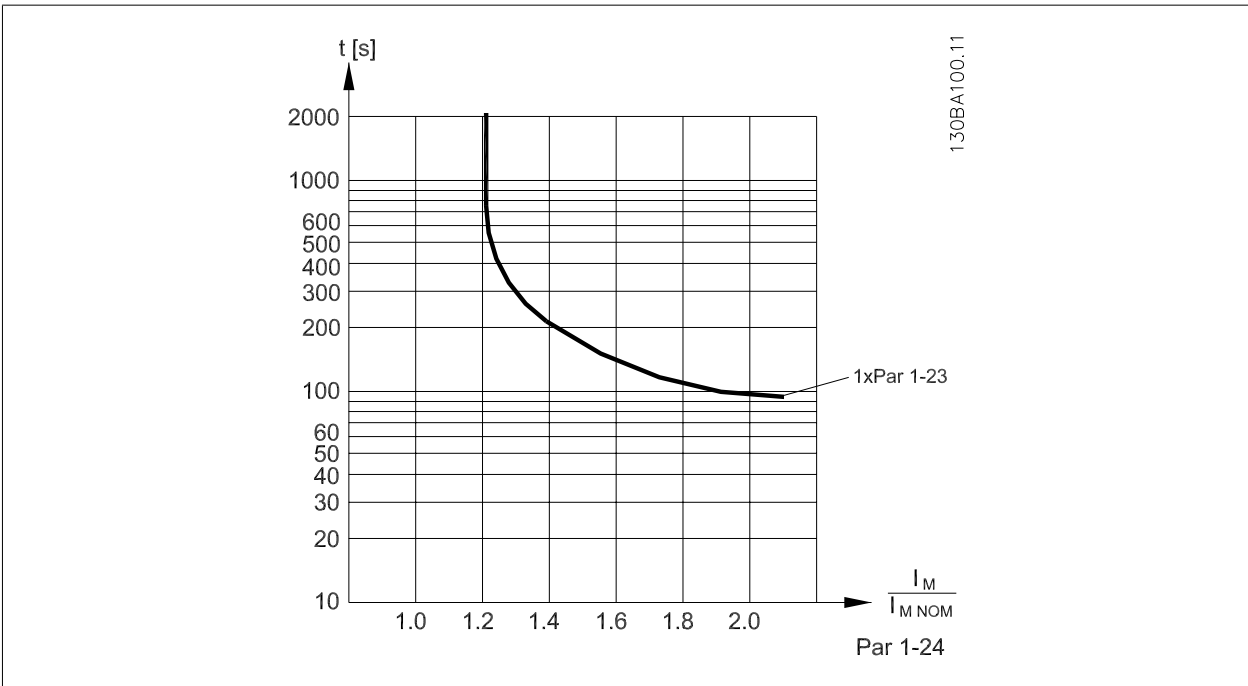

1-93 Thermistor Source

Option:

Function:

Select the input to which the thermistor (PTC sensor) should be connected. An analog input option [1] or [2] cannot be selected if the analog input is already in use as a reference source (selected in par. 3-15 *Reference 1 Source*, par. 3-16 *Reference 2 Source* or par. 3-17 *Reference 3 Source*). When using MCB112, choice [0] *None* must always be selected.

- [0] * None
- [1] Analog input 53
- [2] Analog input 54
- [3] Digital input 18
- [4] Digital input 19
- [5] Digital input 32
- [6] Digital input 33



NOTE!

This parameter cannot be adjusted while the motor is running.



NOTE!

Digital input should be set to [0] *PNP - Active at 24V* in par. 5-00.

3.3.10 KTY Sensor Connection

(FC 302 only)

KTY sensors are used especially in permanent magnet servo motors (PM motors) for dynamic adjusting of motor parameters as stator resistance (par. 1-30 *Stator Resistance (Rs)*) for PM motors and also rotor resistance (par. 1-31 *Rotor Resistance (Rr)*) for asynchronous motors, depending on winding temperature. The calculation is:

$$R_s = R_{s_{20^\circ C}} \times (1 + \alpha_{Cu} \times \Delta T) [\Omega] \text{ where } \alpha_{Cu} = 0.00393$$

KTY sensors can be used for motor protecting (par. 1-97 *KTY Threshold level*).

FC 302 can handle three types of KTY sensors, defined in par. 1-95 *KTY Sensor Type*. The actual sensor temperature can be read out from par. 16-19 *KTY sensor temperature*.

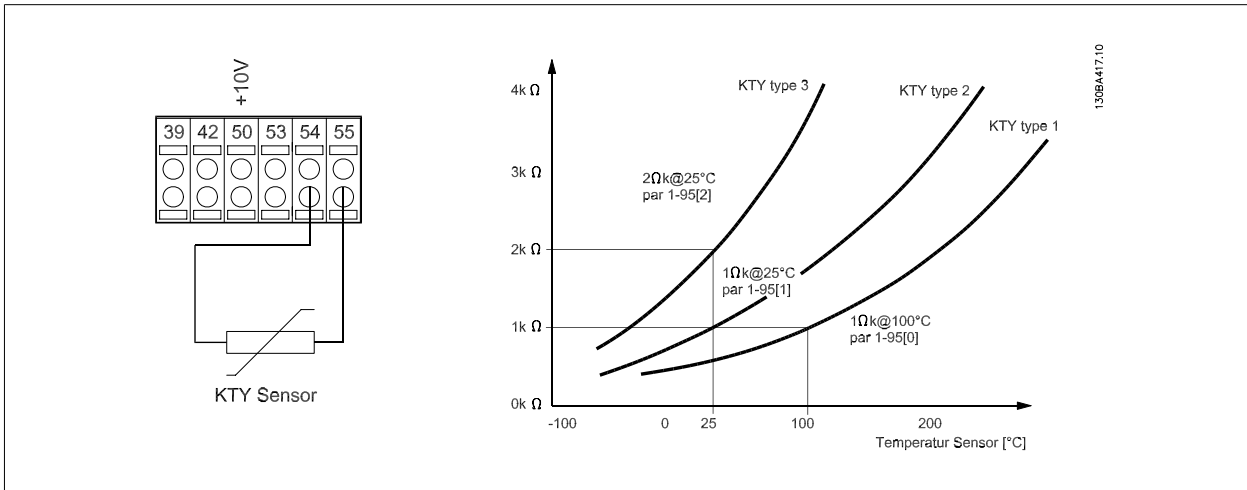
**NOTE!**

If the temperature of the motor is utilized through a thermistor or KTY sensor, the PELV is not complied with in the event of short circuits between motor windings and sensor. In order to comply with PELV, the sensor must be extra isolated.

1-95 KTY Sensor Type**Option:****Function:**

Select the used type of KTY sensor. This parameter is available for the FC 302 only.

[0] *	KTY Sensor 1	1 kΩ at 212°F [100°C]
[1]	KTY Sensor 2	1 kΩ at 77°F [25°C]
[2]	KTY Sensor 3	2 kΩ at 77°F [25°C]

1-96 KTY Thermistor Resource**Option:****Function:**

Selecting analog input terminal 54 to be used as KTY sensor input. Terminal 54 cannot be selected as KTY source if otherwise used as reference (see par. 3-15 *Reference Resource 1* to par. 3-17 *Reference Resource 3*).

This parameter is available for the FC 302 only.

**NOTE!**

Connection of KTY sensor between term. 54 and 55 (GND). See picture in section *KTY Sensor Connection*.

[0] *	None
[2]	Analog input 54

1-97 KTY Threshold level**Range:****Function:**

80 C*	[-40 - 140 C]
-------	---------------

3.4 Parameters: Brakes

3.4.1 2-*** Brakes

Parameter group for setting brake features in the adjustable frequency drive.

3.4.2 2-0* DC Brakes

Parameter group for configuring the DC brake and DC hold functions.

2-00 DC Hold Current

Range:

50 %* [Application dependant]

Function:

Enter a value for holding current as a percentage of the rated motor current $I_{M,N}$ set in par. 1-24 *Motor Current*. 100% DC holding current corresponds to $I_{M,N}$.
 This parameter holds the motor function (holding torque) or pre-heats the motor.
 This parameter is active if *DC hold* is selected in par. 1-72 *Start Function* [0] or par. 1-80 *Function at Stop* [1].



NOTE!

The maximum value depends on the rated motor current.

NOTE!

Avoid 100% current for too long, as it may damage the motor. It may damage the motor.

2-01 DC Brake Current

Range:

50 %* [Application dependant]

Function:

Enter a value for current as a percentage of the rated motor current $I_{M,N}$, see par. 1-24 *Motor Current*. 100% DC braking current corresponds to $I_{M,N}$.
 DC brake current is applied on a stop command, when the speed is lower than the limit set in par. 2-03 *DC Brake Cut-in Speed [RPM]*; when the DC Brake Inverse function is active; or via the serial communication port. The braking current is active during the time period set in par. 2-02 *DC Braking Time*.



NOTE!

The maximum value depends on the rated motor current.

NOTE!

Avoid 100% current for too long, as it may damage the motor. It may damage the motor.

2-02 DC Braking Time

Range:

10.0 s* [0.0 - 60.0 s]

Function:

Set the duration of the DC braking current set in par. 2-01 *DC Brake Current*, once activated.

2-03 DC Brake Cut-in Speed [RPM]

Range:

Application dependant* [Application dependant]

Function:

2-04 DC Brake Cut-in Speed [Hz]

Range:

 Application [Application dependant]
 dependent*

Function:

3

3.4.3 2-1* Brake Energy Funct.

Parameter group for selecting dynamic braking parameters. Only valid for drives with brake chopper.

2-10 Brake Function

Option:

[0] * Off

[1] Resistor brake

[2] AC brake

Function:

No brake resistor is installed.

A brake resistor is incorporated in the system, for dissipating surplus brake energy as heat. Connecting a brake resistor allows a higher DC link voltage during braking (generating operation). The resistor brake function is only active in adjustable frequency drives with an integral dynamic brake.

 Is selected to improve braking without using a brake resistor. This parameter controls an overmagnetization of the motor when running with a generative load. This function can improve the OVC function. Increasing the electrical losses in the motor allows the OVC function to increase the braking torque without exceeding the overvoltage limit. Please note that AC brake is not as effective as dynamic braking with resistor.
 AC brake is for VVC⁺ and flux mode in both open-loop and closed-loop.

2-11 Brake Resistor (ohm)

Range:

 Application [Application dependant]
 dependent*

Function:

2-12 Brake Power Limit (kW)

Range:

 Application [Application dependant]
 dependent*

Function:

For 200–240 V units:

$$P_{resistor} = \frac{390^2 \times dutytime}{R \times 120}$$

For 380–480 V units

$$P_{resistor} = \frac{778^2 \times dutytime}{R \times 120}$$

For 380–500 V units

$$P_{resistor} = \frac{810^2 \times dutytime}{R \times 120}$$

For 575–600 V units

$$P_{resistor} = \frac{943^2 \times dutytime}{R \times 120}$$

This parameter is only active in adjustable frequency drives with an integral dynamic brake.

2-13 Brake Power Monitoring

Option:

[0] * Off

Function:

 This parameter is only active in adjustable frequency drives with an integral dynamic brake. This parameter enables monitoring of the power to the brake resistor. The power is calculated on the basis of the resistance (par. 2-11 *Brake Resistor (ohm)*), the DC-link voltage, and the resistor duty time.

No braking energy monitoring required.

[1]	Warning	Activates a warning on the display when the power transmitted over 120 s exceeds 100% of the monitoring limit (par. 2-12 <i>Brake Power Limit (kW)</i>). The warning disappears when the transmitted power falls below 80% of the monitoring limit.
[2]	Trip	Trips adjustable frequency drive and displays an alarm when the calculated power exceeds 100% of the monitoring limit.
[3]	Warning and trip	Activates both of the above, including warning, trip and alarm.

If power monitoring is set to *Off*[0] or *Warning* [1], the brake function remains active, even if the monitoring limit is exceeded. This may lead to thermal overload of the resistor. It is also possible to generate a warning via a relay/digital output. The measuring accuracy of the power monitoring depends on the accuracy of the resistance of the resistor (better than ± 20%).

2-15 Brake Check

Option:

Function:

Select type of test and monitoring function to check the connection to the brake resistor, or whether a brake resistor is present, and then display a warning or an alarm in the event of a fault.



NOTE!

The brake resistor disconnection function is tested during power-up. However, the brake IGBT test is performed when there is no braking. A warning or trip disconnects the brake function.

The testing sequence is as follows:

1. The DC link ripple amplitude is measured for 300 ms without braking.
2. The DC link ripple amplitude is measured for 300 ms with the brake turned on.
3. If the DC link ripple amplitude while braking is lower than the DC link ripple amplitude before braking +1%: Brake check has failed and will return a warning or alarm.
4. If the DC link ripple amplitude while braking is higher than the DC link ripple amplitude before braking +1%: Brake check is OK.

[0] *	Off	Monitors brake resistor and brake IGBT for a short-circuit during operation. If a short-circuit occurs, warning 25 appears.
[1]	Warning	Monitors brake resistor and brake IGBT for a short-circuit, and runs a test for brake resistor disconnection during power-up.
[2]	Trip	Monitors for a short-circuit or disconnection of the brake resistor, or a short-circuit of the brake IGBT. If a fault occurs, the adjustable frequency drive cuts out while displaying an alarm (trip locked).
[3]	Stop and trip	Monitors for a short-circuit or disconnection of the brake resistor, or a short-circuit of the brake IGBT. If a fault occurs, the adjustable frequency drive ramps down to coast and then trips. A trip lock alarm is displayed (e.g., warning 25, 27 or 28).
[4]	AC brake	Monitors for a short-circuit or disconnection of the brake resistor, or a short-circuit of the brake IGBT. If a fault occurs, the adjustable frequency drive performs a controlled ramp-down. This option is only available for the FC 302.
[5]	Trip Lock	



NOTE!

Remove a warning arising in connection with *Off*[0] or *Warning* [1] by cycling the line power supply. The fault must be corrected first. For *Off*[0] or *Warning* [1], the adjustable frequency drive keeps running even if a fault is located.

This parameter is only active in adjustable frequency drives with an integral dynamic brake.

2-16 AC Brake Max. Current

Range:

100.0 %* [Application dependant]

Function:

Enter the maximum permissible current when using AC brake to avoid overheating motor windings. The AC brake function is available in flux mode only (FC 302 only).

2-17 Over-voltage Control

Option:
Function:

Overvoltage control (OVC) reduces the risk of the adjustable frequency drive tripping due to over-voltage on the DC link caused by generative power from the load.

[0] * Disabled

No OVC required.

[1] Enabled (not at stop)

Activates OVC except when using a stop signal to stop the adjustable frequency drive.

[2] Enabled

Activates OVC.

NOTE!

OVC must not be enabled in hoisting applications.

2-18 Brake Check Condition

Option:
Function:

[0] * At Power Up

Brake check will be performed at power-up

[1] After Coast Situations

Brake check will be performed after coast situations

3.4.4 2-2* Mechanical Brake

Parameters for controlling operation of an electro-magnetic (mechanical) brake, typically required in hoisting applications.

To control a mechanical brake, a relay output (relay 01 or relay 02) or a programmed digital output (terminal 27 or 29) is required. Normally, this output must be closed during periods when the adjustable frequency drive is unable to 'hold' the motor, e.g., due to an excessive load. Select *Mechanical Brake Control* [32] for applications with an electro-magnetic brake in par. 5-40 *Function Relay*, par. 5-30 *Terminal 27 Digital Output*, or par. 5-31 *Terminal 29 digital Output*. When selecting *Mechanical brake control* [32], the mechanical brake is closed from start up until the output current is above the level selected in par. 2-20 *Release Brake Current*. During stop, the mechanical brake activates when the speed falls below the level specified in par. 2-21 *Activate Brake Speed [RPM]*. If the adjustable frequency drive enters an alarm condition or an overcurrent or overvoltage situation, the mechanical brake immediately cuts in. This is also the case during safe stop.

NOTE!

Protection mode and trip delay features (par. 14-25 *Trip Delay at Torque Limit* and par. 14-26 *Trip Delay at Inverter Fault*) may delay the activation of the mechanical brake in an alarm condition. These features must be disabled in hoisting applications.

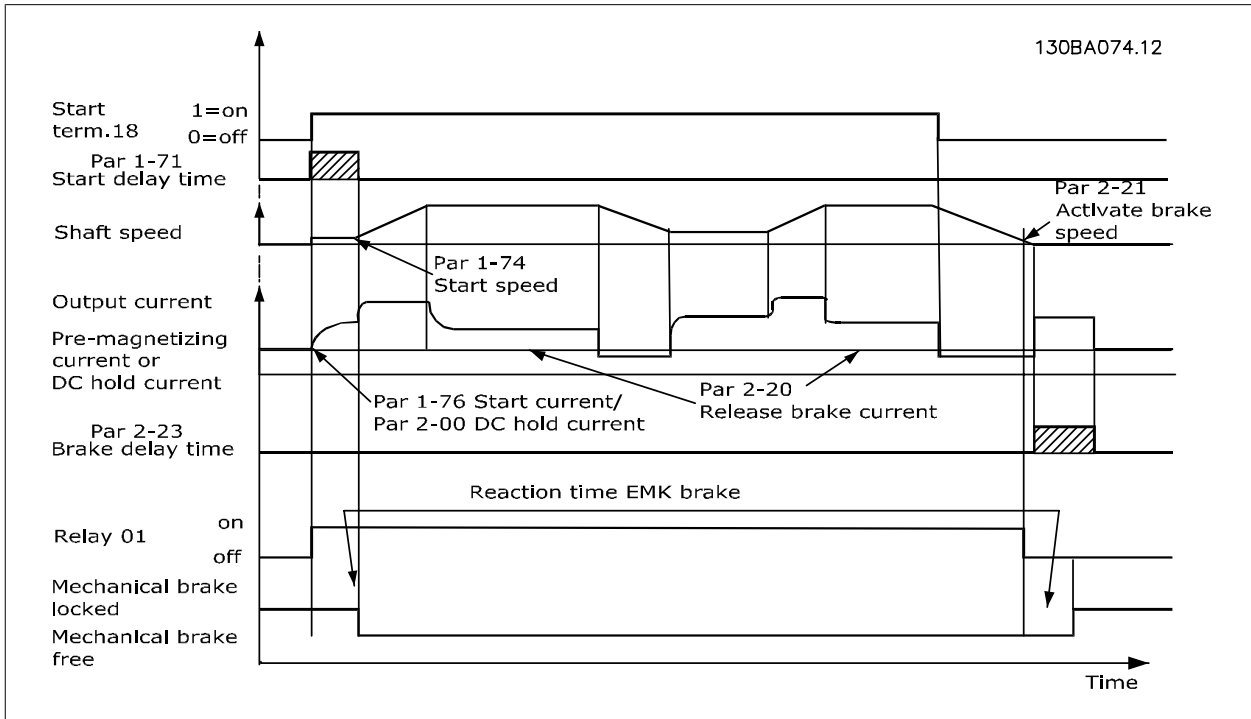

2-20 Release Brake Current

Range: **Function:**

Application [Application dependant]
dependent*

2-21 Activate Brake Speed [RPM]

Range: **Function:**

Application [0 - 30000 RPM]
dependent* Set the motor speed for activation of the mechanical brake when a stop condition is present. The upper speed limit is specified in par. 4-53 *Warning Speed High*.

2-22 Activate Brake Speed [Hz]

Range: **Function:**

Application [Application dependant]
dependent*

2-23 Activate Brake Delay

Range: **Function:**

0.0 s* [0.0 - 5.0 s] Enter the brake delay time of the coast after ramp-down time. The shaft is held at zero speed with full holding torque. Ensure that the mechanical brake has locked the load before the motor enters coast mode. See the *Mechanical Brake Control* section in the Design Guide.

2-24 Stop Delay

Range: **Function:**

0.0 s* [0.0 - 5.0 s] Set the time interval from the moment when the motor is stopped until the brake closes. This parameter is a part of the stopping function.

2-25 Brake Release Time**Range:**

0.20 s* [0.00 - 5.00 s]

Function:

This value defines the time it takes for the mechanical brake to open. This parameter must act as a timeout when brake feedback is activated.

2-26 Torque Ref**Range:**

0.00 %* [Application dependant]

Function:

The value defines the torque applied against the closed mechanical brake before release

2-27 Torque Ramp Time**Range:**

0.2 s* [0.0 - 5.0 s]

Function:

The value defines the duration of the torque ramp in clockwise direction.

2-28 Gain Boost Factor**Range:**

1.00* [1.00 - 4.00]

Function:

Only active in flux closed-loop. The function ensures a smooth transition from torque control mode to speed control mode when the motor takes over the load from the brake.

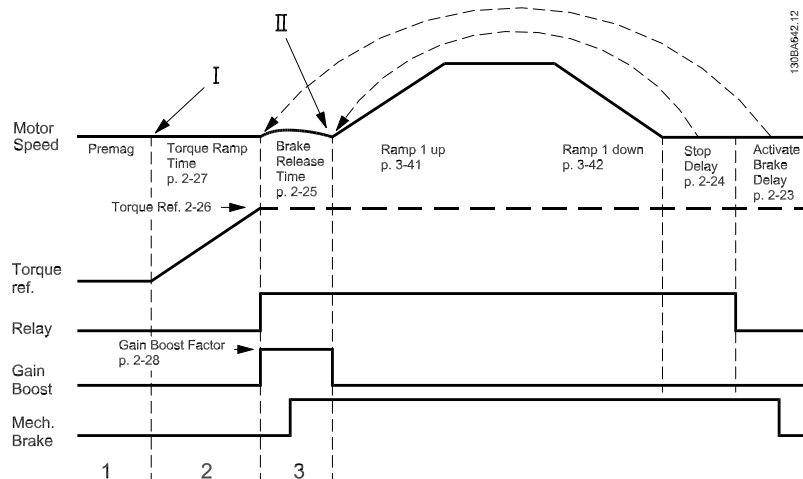

Figure 3.6: Brake release sequence for hoist mechanical brake control

I) *Activate brake delay*: The adjustable frequency drive starts again from the *mechanical brake engaged* position.

II) *Stop delay*: When the time between successive starts is shorter than the setting in par. 2-24 *Stop Delay*, the adjustable frequency drive starts without applying the mechanical brake (e.g., reversing).

3.5 Parameters: Reference/Ramps

3.5.1 3-** Reference/Reference Limits/Ramps

Parameters for reference handling, defining limitations and configuring the reaction of the adjustable frequency drive to changes.

3.5.2 3-0* Reference Limits

Parameters for setting the reference unit, limits and ranges.

3-00 Reference Range

Option:	Function:
	Select the range of the reference signal and the feedback signal. Signal values can be positive only, or positive and negative. The minimum limit may have a negative value, unless <i>Speed closed-loop</i> [1] control or <i>Process</i> [3] is selected in par. 1-00 <i>Configuration Mode</i> .
[0] Min to Max	Select the range of the reference signal and the feedback signal. Signal values can be positive only, or positive and negative. The minimum limit may have a negative value, unless <i>Speed closed-loop</i> [1] control or <i>Process</i> [3] is selected in par. 1-00 <i>Configuration Mode</i> .
[1] * -Max to +Max	For both positive and negative values (both directions, relative to par. 4-10 <i>Motor Speed Direction</i>).

3-01 Reference/Feedback Unit

Option:	Function:
	Select the unit to be used in process PID control references and feedback.
[0] * None	
[1] %	
[2] rpm	
[3] Hz	
[4] Nm	
[5] PPM	
[10] min	
[12] PULSE/s	
[20] liter / sec.	
[21] liter / min	
[22] liter / hr.	
[23] m ³ / sec.	
[24] m ³ /min	
[25] m ³ / hr.	
[30] kg / sec.	
[31] kg/min	
[32] kg / hr.	
[33] ton / min	
[34] ton / hr.	
[40] m / sec.	
[41] m/min	
[45] m	
[60] °C	
[70] mbar	
[71] bar	
[72] Pa	
[73] kPa	
[74] m WG	
[80] kW	
[120] GPM	
[121] gal / sec.	

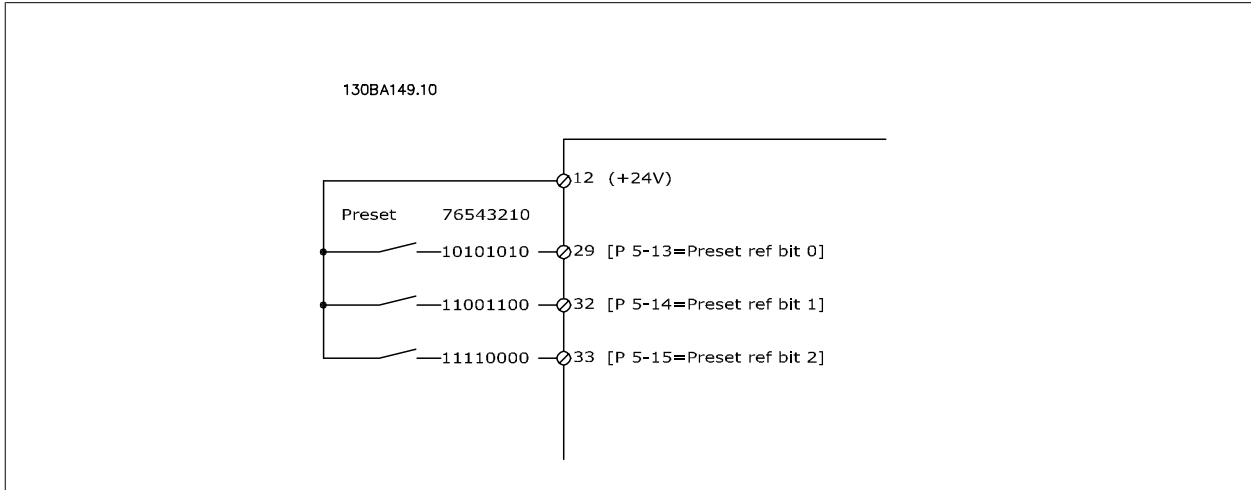

Preset ref. bit	2	1	0
Preset ref. 0	0	0	0
Preset ref. 1	0	0	1
Preset ref. 2	0	1	0
Preset ref. 3	0	1	1
Preset ref. 4	1	0	0
Preset ref. 5	1	0	1
Preset ref. 6	1	1	0
Preset ref. 7	1	1	1

3-11 Jog Speed [Hz]

Range:

Function:

Application [Application dependant]
dependent*

3-12 Catch up/slow-down Value

Range:

Function:

0.00 %* [0.00 - 100.00 %]

3-13 Reference Site

Option:

Function:

Select which reference site to activate.

- [0] * Linked to Hand / Auto Use local reference when in hand mode; or remote reference when in auto mode.
- [1] Remote Use remote reference in both hand mode and auto mode.
- [2] Local Use local reference in both hand mode and auto mode.



NOTE!

When set to Local [2], the adjustable frequency drive will start with this setting again following a 'power-down'.

3-14 Preset Relative Reference**Range:**

0.00 %* [-100.00 - 100.00 %]

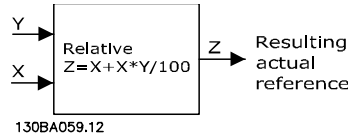
Function:

130BA278.10

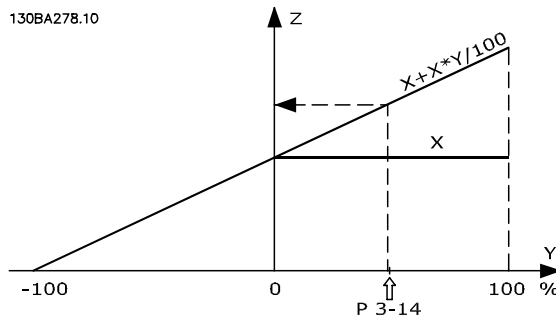
**3-15 Reference Resource 1****Option:****Function:**

Select the reference input to be used for the first reference signal. par. 3-15 *Reference Resource 1*, par. 3-16 *Reference Resource 2* and par. 3-17 *Reference Resource 3* define up to three different reference signals. The sum of these reference signals defines the actual reference.

[0]	No function	
[1] *	Analog input 53	
[2]	Analog input 54	
[7]	Frequency input 29	
[8]	Frequency input 33	
[11]	Local bus reference	
[20]	Digital pot.meter	
[21]	Analog input X30-11	(General Purpose I/O Option Module)
[22]	Analog input X30-12	(General Purpose I/O Option Module)

3-16 Reference Resource 2**Option:****Function:**

Select the reference input to be used for the second reference signal. par. 3-15 *Reference Resource 1*, par. 3-16 *Reference Resource 2* and par. 3-17 *Reference Resource 3* define up to three different reference signals. The sum of these reference signals defines the actual reference.

[0]	No function
[1]	Analog input 53
[2]	Analog input 54
[7]	Frequency input 29

- [8] Frequency input 33
- [11] Local bus reference
- [20] * Digital pot.meter
- [21] Analog input X30-11
- [22] Analog input X30-12

3-17 Reference Resource 3

Option:

Function:

Select the reference input to be used for the third reference signal. par. 3-15 *Reference Resource 1*, par. 3-16 *Reference Resource 2* and par. 3-17 *Reference Resource 3* define up to three different reference signals. The sum of these reference signals defines the actual reference.

- [0] No function
- [1] Analog input 53
- [2] Analog input 54
- [7] Frequency input 29
- [8] Frequency input 33
- [11] * Local bus reference
- [20] Digital pot.meter
- [21] Analog input X30-11
- [22] Analog input X30-12

3-18 Relative Scaling Reference Resource

Option:

Function:

Select a variable value to be added to the fixed value (defined in par. 3-14 *Preset Relative Reference*). The sum of the fixed and variable values (labeled Y in the figure below) is multiplied by the actual reference (labeled X in the figure below). The result is then added to the actual reference ($X + X*Y/100$) to give the resulting actual reference.

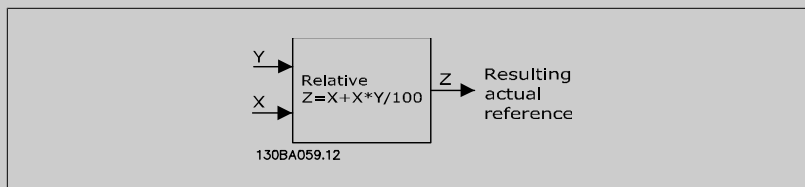

This parameter cannot be adjusted while the motor is running.

- [0] * No function
- [1] Analog input 53
- [2] Analog input 54
- [7] Frequency input 29
- [8] Frequency input 33
- [11] Local bus reference
- [20] Digital pot.meter
- [21] Analog input X30-11
- [22] Analog input X30-12

3-19 Jog Speed [RPM]

Range:

Application [Application dependant]
dependent*

Function:

3

3.5.4 Ramps
3-4* Ramp 1

For each of four ramps (par. 3-4*, par. 3-5*, par. 3-6* and par. 3-7*) configure the ramp parameters: ramp type, ramping times (duration of acceleration and deceleration) and level of jerk compensation for S ramps.

Start by setting the linear ramping times corresponding to the figures.

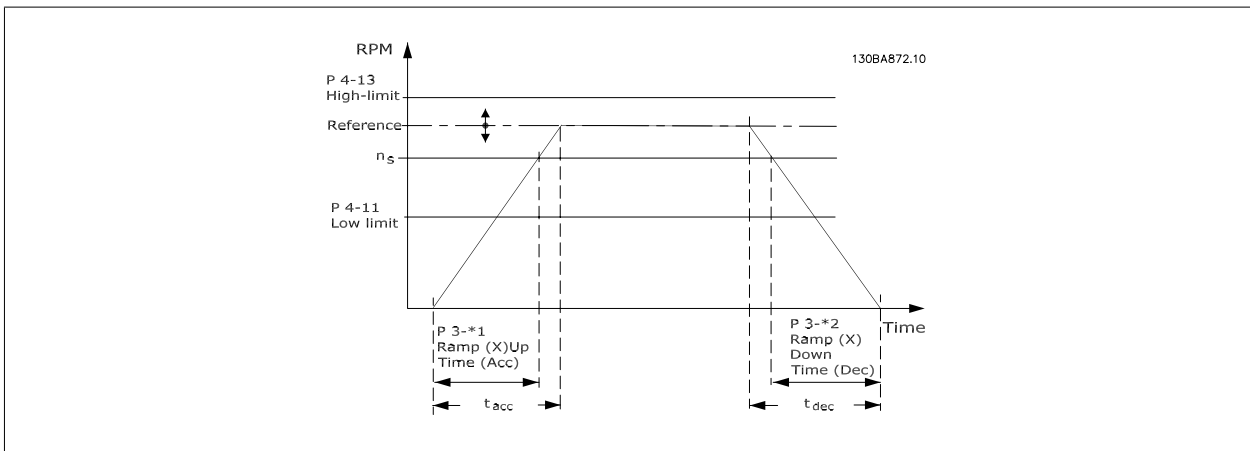

If S-ramps are selected, then set the level of non-linear jerk compensation required. Set jerk compensation by defining the proportion of ramp-up and ramp-down times where acceleration and deceleration are variable (i.e., increasing or decreasing). The S-ramp acceleration and deceleration settings are defined as a percentage of the actual ramp time.

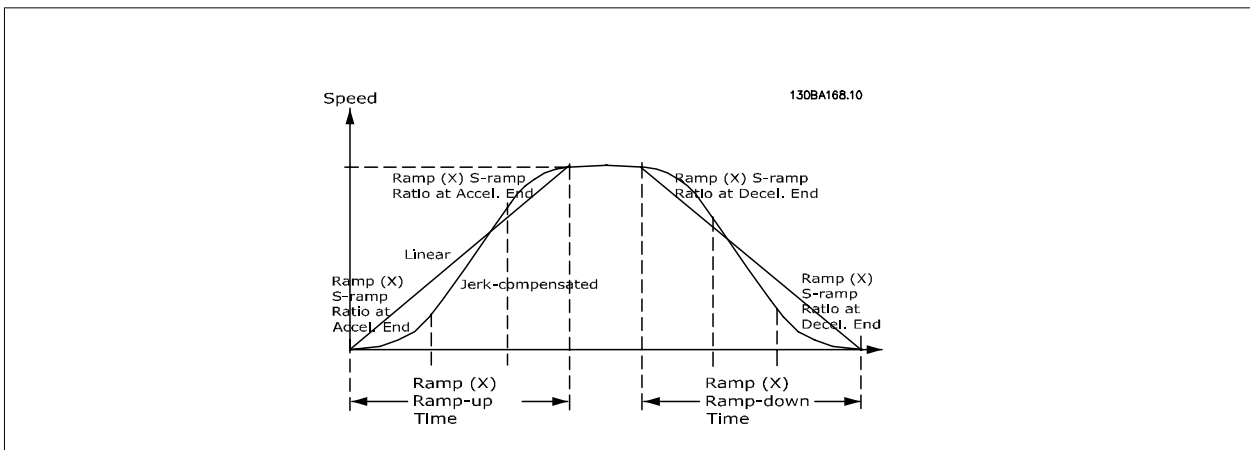

3-40 Ramp 1 Type

Option:

Function:

Select the ramp type, depending on requirements for acceleration/deceleration.

		A linear ramp will give constant acceleration during ramping. An S-ramp will give non-linear acceleration, compensating for jerk in the application.
[0] *	Linear	
[1]	S-ramp	Acceleration with lowest possible jerk.
[2]	S-ramp Const Time	S-ramp based on the values set in par. 3-41 <i>Ramp 1 Ramp-up Time</i> and par. 3-42 <i>Ramp 1 Ramp-down Time</i> .

NOTE!
 If S-ramp [1] is selected and the reference during ramping is changed, the ramp time may be prolonged in order to realize a jerk-free movement, which may result in a longer start or stop time.
 Additional adjustment of the S-ramp ratios or switching initiators may be necessary.

3-41 Ramp 1 Ramp-up Time

Range:	Function:
Application [Application dependant] dependent*	

3-42 Ramp 1 Ramp-down Time

Range:	Function:
Application [Application dependant] dependent*	

3-45 Ramp 1 S-ramp Ratio at Accel. Start

Range:	Function:
50 %* [Application dependant]	Enter the proportion of the total ramp-up time (par. 3-41 <i>Ramp 1 Ramp-up Time</i>) in which the acceleration torque increases. The larger the percentage value, the greater the jerk compensation achieved, and thus the lower the torque jerks occurring in the application.

3-46 Ramp 1 S-ramp Ratio at Accel. End

Range:	Function:
50 %* [Application dependant]	Enter the proportion of the total ramp-up time (par. 3-41 <i>Ramp 1 Ramp-up Time</i>) in which the acceleration torque decreases. The larger the percentage value, the greater the jerk compensation achieved, and thus the lower the torque jerks in the application.

3-47 Ramp 1 S-ramp Ratio at Decel. Start

Range:	Function:
50 %* [Application dependant]	Enter the proportion of the total ramp-down time (par. 3-42 <i>Ramp 1 Ramp-down Time</i>) where the deceleration torque increases. The larger the percentage value, the greater the jerk compensation achieved, and thus the lower the torque jerks in the application.

3-48 Ramp 1 S-ramp Ratio at Decel. End

Range:	Function:
50 %* [Application dependant]	Enter the proportion of the total ramp-down time (par. 3-42 <i>Ramp 1 Ramp-down Time</i>) where the deceleration torque decreases. The larger the percentage value, the greater the jerk compensation achieved, and thus the lower the torque jerks in the application.

3.5.5 3-5* Ramp 2

Choosing ramp parameters, see 3-4*.

3-50 Ramp 2 Type

Option:
Function:

Select the ramp type, depending on requirements for acceleration/deceleration. A linear ramp will give constant acceleration during ramping. An S-ramp will give non-linear acceleration, compensating for jerk in the application.

[0] * Linear

[1] S-ramp

Acceleration with lowest possible jerk

[2] S-ramp Const Time

S-ramp based on the values set in par. 3-51 *Ramp 2 Ramp-up Time* and par. 3-52 *Ramp 2 Ramp-down Time*

NOTE!

If S-ramp [1] is selected and the reference during ramping is changed, the ramp time may be prolonged in order to realize a jerk-free movement, which may result in a longer start or stop time.

Additional adjustment of the S-ramp ratios or switching initiators may be necessary.

3-51 Ramp 2 Ramp-up Time

Range:
Function:

Application [Application dependant]
dependent*

3-52 Ramp 2 Ramp-down Time

Range:
Function:

Application [Application dependant]
dependent*

3-55 Ramp 2 S-ramp Ratio at Accel. Start

Range:
Function:

50 %* [Application dependant]

Enter the proportion of the total ramp-up time (par. 3-51 *Ramp 2 Ramp-up Time*) in which the acceleration torque increases. The larger the percentage value, the greater the jerk compensation achieved, and thus the lower the torque jerks in the application.

3-56 Ramp 2 S-ramp Ratio at Accel. End

Range:
Function:

50 %* [Application dependant]

Enter the proportion of the total ramp-up time (par. 3-51 *Ramp 2 Ramp-up Time*) in which the acceleration torque decreases. The larger the percentage value, the greater the jerk compensation achieved, and thus the lower the torque jerks in the application.

3-57 Ramp 2 S-ramp Ratio at Decel. Start

Range:
Function:

50 %* [Application dependant]

Enter the proportion of the total ramp-down time (par. 3-52 *Ramp 2 Ramp-down Time*) where the deceleration torque increases. The larger the percentage value, the greater the jerk compensation achieved, and thus the lower the torque jerks in the application.

3-58 Ramp 2 S-ramp Ratio at Decel. End

Range:

50 %* [Application dependant]

Function:

Enter the proportion of the total ramp-down time (par. 3-52 *Ramp 2 Ramp-down Time*) where the deceleration torque decreases. The larger the percentage value, the greater the jerk compensation achieved, and thus the lower the torque jerks in the application.

3.5.6 3-6* Ramp 3

Configure ramp parameters, see 3-4*.

3-60 Ramp 3 Type

Option:

- [0] * Linear
- [1] S-ramp
- [2] S-ramp Const Time

Function:

Select the ramp type, depending on requirements for acceleration and deceleration. A linear ramp will give constant acceleration during ramping. An S-ramp will give non-linear acceleration, compensating for jerk in the application.

Accelerates with lowest possible jerk.

S-ramp based on the values set in par. 3-61 *Ramp 3 Ramp-up Time* and par. 3-62 *Ramp 3 Ramp-down Time*



NOTE!

If S-ramp [1] is selected and the reference during ramping is changed, the ramp time may be prolonged in order to realize a jerk-free movement, which may result in a longer start or stop time. Additional adjustment of the S-ramp ratios or switching initiators may be necessary.

3-61 Ramp 3 Ramp-up Time

Range:

Application [Application dependant] dependent*

Function:

3-62 Ramp 3 Ramp-down Time

Range:

Application [Application dependant] dependent*

Function:

3-65 Ramp 3 S-ramp Ratio at Accel. Start

Range:

50 %* [Application dependant]

Function:

Enter the proportion of the total ramp-up time (par. 3-61 *Ramp 3 Ramp-up Time*) in which the acceleration torque increases. The larger the percentage value, the greater the jerk compensation achieved, and thus the lower the torque jerks in the application.

3-66 Ramp 3 S-ramp Ratio at Accel. End

Range:

50 %* [Application dependant]

Function:

Enter the proportion of the total ramp-up time (par. 3-61 *Ramp 3 Ramp-up Time*) in which the acceleration torque decreases. The larger the percentage value, the greater the jerk compensation achieved, and thus the lower the torque jerks in the application.

3-67 Ramp 3 S-ramp Ratio at Decel. Start**Range:**

50 %* [Application dependant]

Function:

Enter the proportion of the total ramp-down time (par. 3-62 *Ramp 3 Ramp-down Time*) where the deceleration torque increases. The larger the percentage value, the greater the jerk compensation achieved, and thus the lower the torque jerks in the application.

3-68 Ramp 3 S-ramp Ratio at Decel. End**Range:**

50 %* [Application dependant]

Function:

Enter the proportion of the total ramp-down decel time (par. 3-62 *Ramp 3 Ramp-down Time*) where the deceleration torque decreases. The larger the percentage value, the greater the jerk compensation achieved, and thus the lower the torque jerks in the application.

3.5.7 3-7* Ramp 4

Configure ramp parameters, see 3-4*.

3-70 Ramp 4 Type**Option:**

[0] * Linear

[1] S-ramp

[2] S-ramp Const Time

Function:

Select the ramp type, depending on requirements for acceleration and deceleration. A linear ramp will give constant acceleration during ramping. An S-ramp will give non-linear acceleration, compensating for jerk in the application.

Accelerates with lowest possible jerk.

S-ramp based on the values set in par. 3-71 *Ramp 4 Ramp-up Time* and par. 3-72 *Ramp 4 Ramp-down Time*.

**NOTE!**

If S-ramp [1] is selected and the reference during ramping is changed, the ramp time may be prolonged in order to realize a jerk-free movement, which may result in a longer start or stop time.

Additional adjustment of the S-ramp ratios or switching initiators may be necessary.

3-71 Ramp 4 Ramp-up Time**Range:**

Application dependent* [Application dependant]

Function:**3-72 Ramp 4 Ramp-down Time****Range:**

Application dependent* [Application dependant]

Function:**3-75 Ramp 4 S-ramp Ratio at Accel. Start****Range:**

50 %* [Application dependant]

Function:

Enter the proportion of the total ramp-up time (par. 3-71 *Ramp 4 Ramp-up Time*) in which the acceleration torque increases. The larger the percentage value, the greater the jerk compensation achieved, and thus the lower the torque jerks in the application.

3-76 Ramp 4 S-ramp Ratio at Accel. End

Range:

50 %* [Application dependant]

Function:

Enter the proportion of the total ramp-up time (par. 3-71 *Ramp 4 Ramp-up Time*) in which the acceleration torque decreases. The larger the percentage value, the greater the jerk compensation achieved, and thus the lower the torque jerks in the application.

3-77 Ramp 4 S-ramp Ratio at Decel. Start

Range:

50 %* [Application dependant]

Function:

Enter the proportion of the total ramp-down time (par. 3-72 *Ramp 4 Ramp-down Time*) where the deceleration torque increases. The larger the percentage value, the greater the jerk compensation achieved, and thus the lower the torque jerks in the application.

3-78 Ramp 4 S-ramp Ratio at Decel. End

Range:

50 %* [Application dependant]

Function:

Enter the proportion of the total ramp-down time (par. 3-72 *Ramp 4 Ramp-down Time*) where the deceleration torque decreases. The larger the percentage value, the greater the jerk compensation achieved, and thus the lower the torque jerks in the application.

3.5.8 3-8* Other Ramps

Configure parameters for special ramps such as jog or quick stop, for example.

3-80 Jog Ramp Time

Range:

Application [0.01 - 3600.00 s]
dependent*

Function:

Enter the jog ramp time, i.e., the acceleration/deceleration time between 0 RPM and the rated motor frequency n_s . Ensure that the resultant output current required for the given jog ramp time does not exceed the current limit in par. 4-18 *Current Limit*. The jog ramp time starts upon activation of a jog signal via the control panel, a selected digital input, or the serial communication port. When jog state is disabled, the normal ramping times are valid.

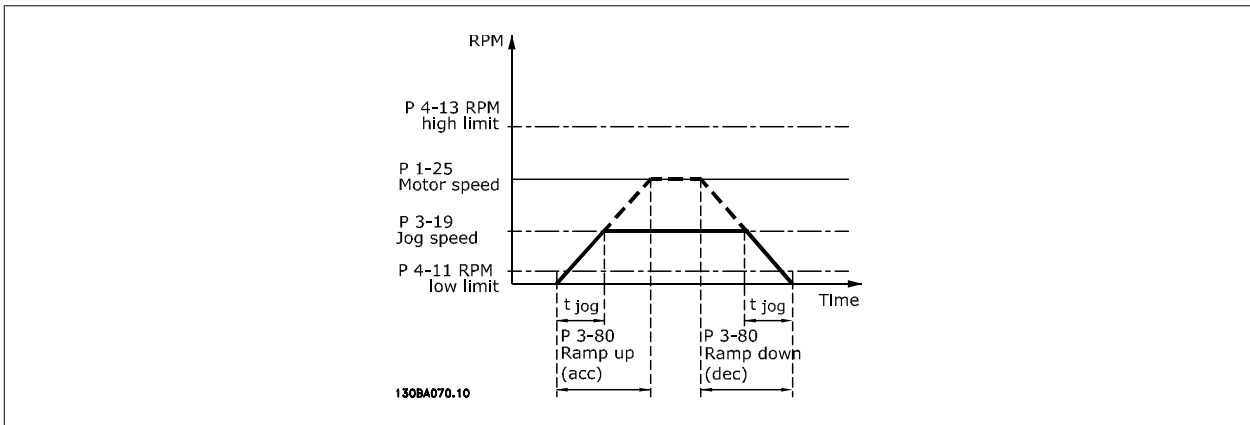

$$Par. 3 - 80 = \frac{t_{jog} [s] \times n_s [RPM]}{\Delta \log speed (par. 3 - 19) [RPM]}$$

3-81 Quick Stop Ramp Time

Range:

Application [0.01 - 3600.00 s]
dependent*

Function:

Enter the quick stop ramp-down time, i.e., the deceleration time from the synchronous motor speed to 0 RPM. Ensure that no resultant overvoltage will arise in the inverter due to regenerative operation

of the motor required to achieve the given ramp-down time. Ensure also that the generated current required to achieve the given ramp-down time does not exceed the current limit (set in par. 4-18 *Current Limit*). Quick stop is activated by means of a signal on a selected digital input, or via the serial communication port.

3

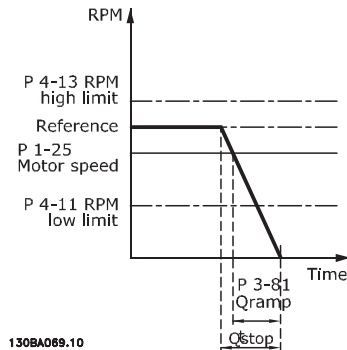

$$Par. 3 - 81 = \frac{t_{Qstop} [s] \times n_s [RPM]}{\Delta jog ref (par. 3 - 19) [RPM]}$$

3-82 Quick Stop Ramp Type

Option:
Function:

Select the ramp type, depending on requirements for acceleration and deceleration. A linear ramp will give constant acceleration during ramping. An S-ramp will give non-linear acceleration, compensating for jerk in the application.

[0] * Linear

[1] S-ramp

[2] S-ramp Const Time

3-83 Quick Stop S-ramp Ratio at Decel. Start

Range:
Function:

50 %* [Application dependant]

Enter the proportion of the total ramp-down time (par. 3-42) during which the deceleration torque increases. The larger the percentage value, the greater the jerk compensation achieved, and thus the lower the torque jerks in the application.

3-84 Quick Stop S-ramp Ratio at Decel. End

Range:
Function:

50 %* [Application dependant]

Enter the proportion of the total ramp-down time (par. 3-42 *Ramp 1 Ramp-down Time*) where the deceleration torque decreases. The larger the percentage value, the greater the jerk compensation achieved, and thus the lower the torque jerks in the application.

3.5.9 3-9* Digital Pot.Meter

The digital potentiometer function allows the user to increase or decrease the actual reference by adjusting the set-up of the digital inputs using the functions *Increase*, *Decrease* or *Clear*. To activate the function, at least one digital input must be set up to *Increase* or *Decrease*.

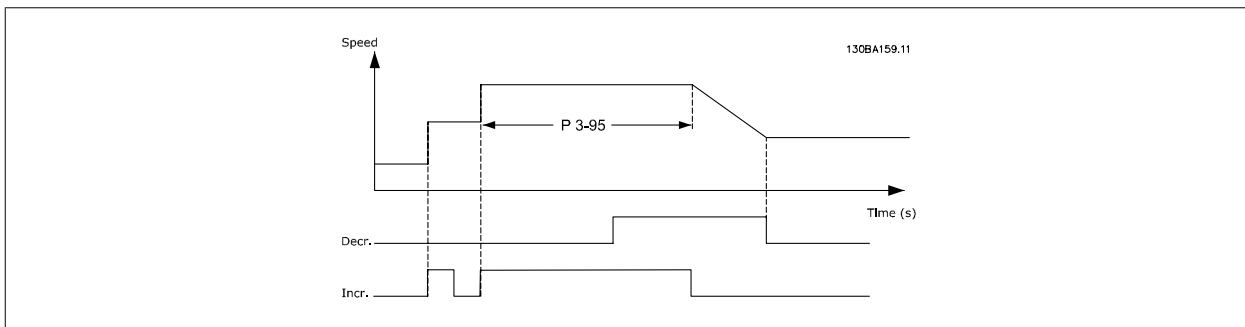
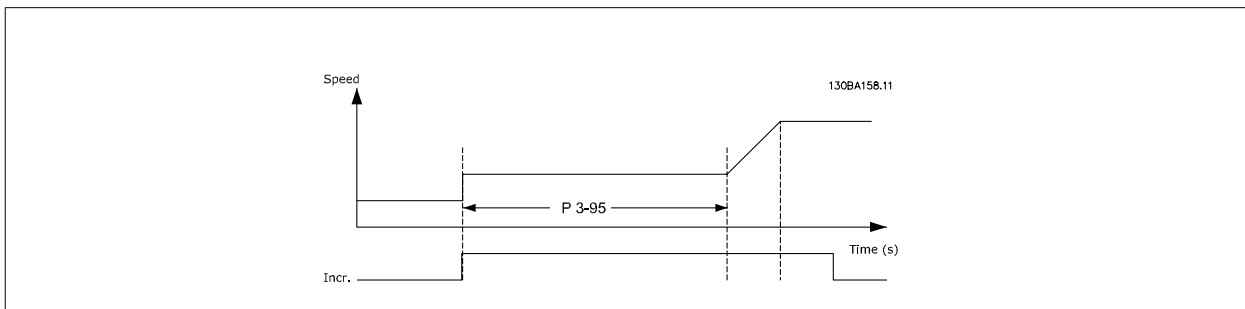

3-90 Step Size

Range: 0.10 %* [0.01 - 200.00 %] **Function:**

3-91 Ramp Time

Range: 1.00 s* [0.00 - 3600.00 s] **Function:**
 Enter the ramp time, i.e., the time for adjustment of the reference from 0% to 100% of the specified digital potentiometer function (Increase, Decrease or Clear).
 If Increase/Decrease is activated for longer than the ramp delay period specified in par. 3-95 *Ramp Delay*, the actual reference will be ramped up/down according to this ramp time. The ramp time is defined as the time used to adjust the reference by the step size specified in par. 3-90 *Step Size*.

3-92 Power Restore

Option: **Function:**
 [0] * Off Resets the Digital Potentiometer reference to 0% after power-up.
 [1] On Restores the most recent Digital Potentiometer reference at power-up.

3-93 Maximum Limit

Range: 100 %* [-200 - 200 %] **Function:**
 Set the maximum permissible value for the resultant reference. This is advisable if the Digital Potentiometer is used for fine tuning of the resulting reference.

3-94 Minimum Limit

Range: -100 %* [-200 - 200 %] **Function:**
 Set the minimum permissible value for the resultant reference. This is advisable if the Digital Potentiometer is used for fine tuning of the resulting reference.

3-95 Ramp Delay

Range:

Application [Application dependant]
dependent*

Function:

3

3.6 Parameters: Limits/Warnings

3.6.1 4-** Limits and Warnings

Parameter group for configuring limits and warnings.

3.6.2 4-1* Motor Limits

Define torque, current and speed limits for the motor, and the reaction of the adjustable frequency drive when the limits are exceeded. A limit may generate a message on the display. A warning will always generate a message on the display or on the serial communication bus. A monitoring function may initiate a warning or a trip, upon which the adjustable frequency drive will stop and generate an alarm message.

4-10 Motor Speed Direction

Option:
Function:

Select the motor speed direction(s) required. Use this parameter to prevent unwanted reversing. When par. 1-00 *Configuration Mode* is set to *Process* [3], par. 4-10 *Motor Speed Direction* is set to *Clockwise* [0] as default. The setting in par. 4-10 *Motor Speed Direction* does not limit options for setting par. 4-13 *Motor Speed High Limit [RPM]*.
This parameter cannot be adjusted while the motor is running.

[0] *	Clockwise	The reference is set to CW rotation. Reversing input (Default term 19) must be open.
[1]	Counterclockwise	The reference is set to CCW rotation. Reversing input (Default term 19) must be closed. If Reversing is required with 'Reverse' input is open the motor direction can be changed by par. 1-06
[2]	Both directions	Allows the motor to rotate in both directions.

4-11 Motor Speed Low Limit [RPM]

Range:

Application [Application dependant]
dependent*

Function:

4-12 Motor Speed Low Limit [Hz]

Range:

Application [Application dependant]
dependent*

Function:

4-13 Motor Speed High Limit [RPM]

Range:

Application [Application dependant]
dependent*

Function:

NOTE!

Max. output frequency cannot exceed 10% of the inverter switching frequency (par. 14-01 *Switching Frequency*).

4-14 Motor Speed High Limit [Hz]

Range: **Function:**

Application [Application dependant]
dependent*



NOTE!

Max. output frequency cannot exceed 10% of the inverter switching frequency (par. 14-01 *Switching Frequency*).

4-16 Torque Limit Motor Mode

Range: **Function:**

Application [Application dependant]
dependent*



Changing par. 4-16 *Torque Limit Motor Mode* when par. 1-00 *Configuration Mode* is set to *Speed open-loop* [0], par. 1-66 *Min. Current at Low Speed* is automatically readjusted.



NOTE!

The adjustable frequency drive is triggered on torque spikes, i.e., the torque limit is detected form internally in the drive and not from LCP or serial communication bus.

4-17 Torque Limit Generator Mode

Range: **Function:**

100.0 %* [Application dependant] This is a true torque limit function that can run into the oversynchronous range above nominal motor speed.
Motor magnetization drop is automatically compensated by a current increase.



NOTE!

The adjustable frequency drive is triggered on torque spikes, i.e., the torque limit is detected form internally in the drive and not from LCP or serial communication bus.

4-18 Current Limit

Range: **Function:**

Application [Application dependant]
dependent*

4-19 Max Output Frequency

Range: **Function:**

132.0 Hz* [1.0 - 1000.0 Hz] Provides a final limit on the output frequency for improved safety in applications where you want to avoid accidental overspeeding. This limit is final in all configurations (independent of the setting in par. 1-00 *Configuration Mode*).

**NOTE!**

Max. output frequency cannot exceed 10% of the inverter switching frequency (par. 14-01 *Switching Frequency*).

Par. 4-19 *Max Output Frequency* cannot be adjusted while the motor is running.

3

4-20 Torque Limit Factor Source**Option:****Function:**

Select an analog input for scaling the settings in par. 4-16 *Torque Limit Motor Mode* and par. 4-17 *Torque Limit Generator Mode* from 0% to 100% (or inverse). The signal levels corresponding to 0% and 100% are defined in the analog input scaling, such as par. group 6-1*, for example. This parameter is only active when par. 1-00 *Configuration Mode* is in *Speed Open-loop* or *Speed Closed-loop*.

[0] *	No function
[2]	Analog in 53
[4]	Analog in 53 inv
[6]	Analog in 54
[8]	Analog in 54 inv
[10]	Analog in X30-11
[12]	Analog in X30-11 inv
[14]	Analog in X30-12
[16]	Analog in X30-12 inv

4-21 Speed Limit Factor Source Option**Option:****Function:**

Select an analog input for scaling the settings in par. 4-19 from 0% to 100% (or vice versa). The signal levels corresponding to 0% and 100% are defined in the analog input scaling, such as par. group 6-1*, for example. This parameter is only active when par. 1-00 *Configuration Mode* is in *Torque Mode*.

[0] *	No function
[2]	Analog input 53
[4]	Analog input 53 inv
[6]	Analog input 54
[8]	Analog input 54 inv
[10]	Analog input X30-11
[12]	Analog input X30-11 inv
[14]	Analog input X30-12
[16]	Analog input X30-12 inv

3.6.3 4-3* Motor Feedback Monitoring

The parameter group includes monitoring and handling of motor feedback devices such as encoders, resolvers, etc.

4-30 Motor Feedback Loss Function

Option:

Function:

Select which reaction the adjustable frequency drive should take if a feedback fault is detected. The selected action is to take place when the feedback signal differs from the output speed where its range is specified in par. 4-31 *Motor Feedback Speed Error* during its time frame set in par. 4-32 *Motor Feedback Loss Timeout*.

- [0] Disabled
- [1] Warning
- [2] * Trip
- [3] Jog
- [4] Freeze Output
- [5] Max Speed
- [6] Switch to Open Loop
- [7] Select Setup 1
- [8] Select Setup 2
- [9] Select Setup 3
- [10] Select Setup 4
- [11] stop & trip

4-31 Motor Feedback Speed Error

Range:

300 RPM* [1 - 600 RPM]

Function:

Select the max. allowed tracking error in speed from the calculated and the actual mechanical shaft output speeds.

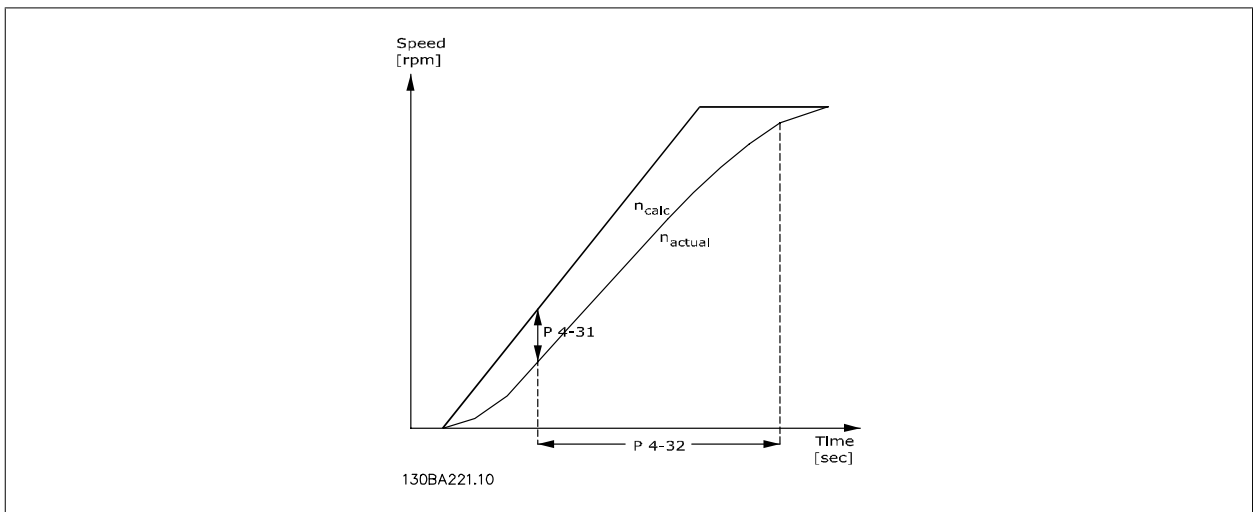

4-32 Motor Feedback Loss Timeout

Range:

0.05 s* [0.00 - 60.00 s]

Function:

Set the timeout value allowing the speed error set in par. 4-31 *Motor Feedback Speed Error* to be exceeded.

4-34 Tracking Error Function**Option:****Function:**

Select how the drive should react when a tracking error is detected, i.e., when the motor speed differs from the output of the ramp.

[0] * Disable

[1] Warning

[2] Trip

[3] Trip after stop

4-35 Tracking Error**Range:****Function:**

10 RPM* [1 - 600 RPM]

Enter the maximum permissible speed error between the motor speed and the output of the ramp when not ramping. In open-loop, the motor speed is estimated, and in closed-loop, it is the feedback from encoder/resolver.

4-36 Tracking Error Timeout**Range:****Function:**

1.00 s* [0.00 - 60.00 s]

Enter the timeout period during which an error greater than the value set in par. 4-35 Tracking Error is permissible.

4-37 Tracking Error Ramping**Range:****Function:**

100 RPM* [1 - 600 RPM]

Enter the maximum permissible speed error between the motor speed and the output of the ramp when ramping. In open-loop, the motor speed is estimated, and in closed-loop, it is the feedback from encoder/resolver.

4-38 Tracking Error Ramping Timeout**Range:****Function:**

1.00 s* [0.00 - 60.00 s]

Enter the timeout period during which an error greater than the value set in par. 4-37 Tracking Error while Ramping is permissible.

4-39 Tracking Error After Ramping Timeout**Range:****Function:**

5.00 s* [0.00 - 60.00 s]

Enter the timeout period after ramping where par. 4-37 and 4-38 are still active.

3.6.4 4-5* Adjustable Warnings

This is where adjustable warning limits for current, speed, reference and feedback can be defined. Warnings that are shown on the display can be programmed as an output or sent via serial bus.

Warnings are shown on display, programmed output or serial bus.

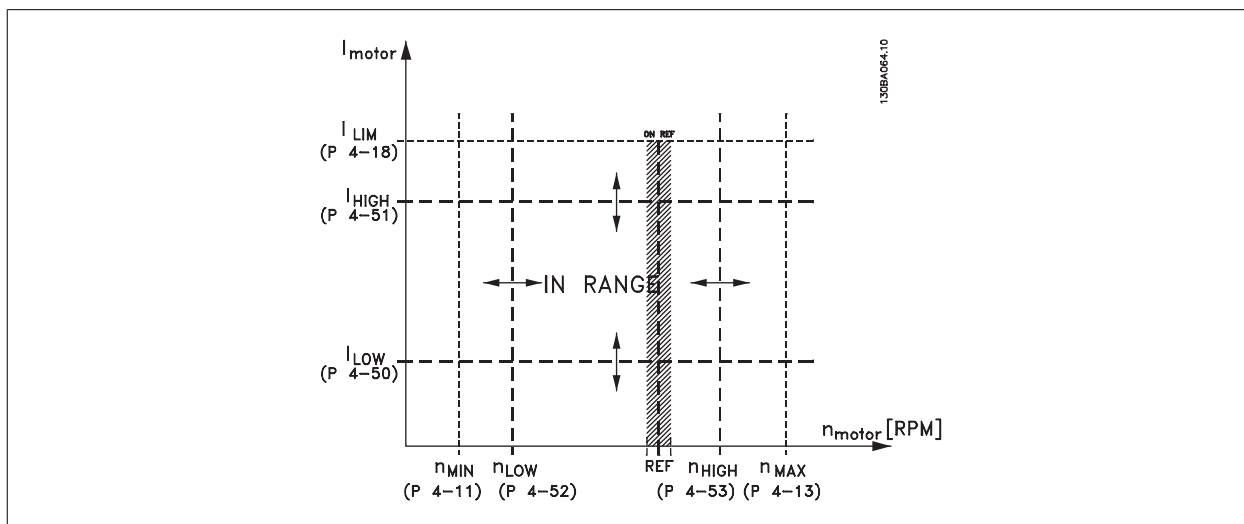

4-50 Warning Current Low

Range:

0.00 A* [Application dependant]

Function:

Enter the I_{LOW} value. When the motor current falls below this limit, the display reads *Current Low*. The signal outputs can be programmed to produce a status signal on terminal 27 or 29 (FC 302 only) and on relay output 01 or 02 (FC 302 only). Refer to the drawing in this section.

4-51 Warning Current High

Range:

Application [Application dependant]
dependant*

Function:

4-52 Warning Speed Low

Range:

0 RPM* [Application dependant]

Function:

Enter the n_{LOW} value. When the motor speed exceeds this limit, the display reads *Speed Low*. The signal outputs can be programmed to produce a status signal on terminal 27 or 29 (FC 302 only) and on relay output 01 or 02 (FC 302 only).

4-53 Warning Speed High

Range:

Application [Application dependant]
dependant*

Function:

4-54 Warning Reference Low

Range:

-999999.99 [Application dependant]
9*

Function:

Enter the lower reference limit. When the actual reference falls below this limit, the display indicates Ref Low. The signal outputs can be programmed to produce a status signal on terminal 27 or 29 (FC 302 only) and on relay output 01 or 02 (FC 302 only).

4-55 Warning Reference High

Range:

999999.999 [Application dependant]
*

Function:

Enter the upper reference limit. When the actual reference exceeds this limit, the display reads Ref High. The signal outputs can be programmed to produce a status signal on terminal 27 or 29 (FC 302 only) and on relay output 01 or 02 (FC 302 only).

4-56 Warning Feedback Low

Range:

-999999.99 [Application dependant]
9 Reference-
ceFeedback-
Unit*

Function:

Enter the lower feedback limit. When the feedback falls below this limit, the display reads Feedb Low. The signal outputs can be programmed to produce a status signal on terminal 27 or 29 (FC 302 only) and on relay output 01 or 02 (FC 302 only).

4-57 Warning Feedback High

Range:

999999.999 [Application dependant]
Reference-
FeedbackU-
nit*

Function:

Enter the upper feedback limit. When the feedback exceeds this limit, the display reads Feedb High. The signal outputs can be programmed to produce a status signal on terminal 27 or 29 (FC 302 only) and on relay output 01 or 02 (FC 302 only).

4-58 Missing Motor Phase Function

Option:

[0] Disabled

Function:

Displays an alarm in the event of a missing motor phase.

No alarm is displayed if a missing motor phase occurs.

[2] * Trip 1000 ms

NOTE!

This parameter cannot be adjusted while the motor is running.

3.6.5 4-6* Speed Bypass

Define the speed bypass areas for the ramps.

Some systems call for avoiding certain output frequencies or speeds due to resonance problems in the system. A maximum of four frequency or speed ranges can be avoided.

4-60 Bypass Speed From [RPM]

Array [4]

Range:

Application [Application dependant]
dependent*

Function:

4-61 Bypass Speed From [Hz]

Array [4]

Range:

Application [Application dependant]
dependent*

Function:

4-62 Bypass Speed to [RPM]

Array [4]

Range:

Application [Application dependant]
dependent*

Function:

4-63 Bypass Speed To [Hz]

Array [4]

Range:

Application [Application dependant]
dependent*

Function:

3.7 Parameters: Digital In/Out

3.7.1 5-** Digital In/Out

Parameter group for configuring the digital input and output.

3.7.2 5-0* Digital I/O Mode

Parameters for configuring the input and output using NPN and PNP.

5-00 Digital I/O Mode

Option:

Function:

Digital inputs and programmed digital outputs are pre-programmable for operation either in PNP or NPN systems.

[0] * PNP

Action on positive directional pulses (+). PNP systems are pulled down to GND.

[1] NPN

Action on negative directional pulses (+). NPN systems are pulled up to + 24 V, internally in the adjustable frequency drive.



NOTE!

Once this parameter has been changed, it must be activated by performing a power cycle.

This parameter cannot be adjusted while the motor is running.

5-01 Terminal 27 Mode

Option:

Function:

[0] * Input

Defines terminal 27 as a digital input.

[1] Output

Defines terminal 27 as a digital output.

Please note that this parameter cannot be adjusted while the motor is running.

5-02 Terminal 29 Mode

Option:

Function:

[0] * Input

Defines terminal 29 as a digital input.

[1] Output

Defines terminal 29 as a digital output.

This parameter is available for the FC 302 only.

This parameter cannot be adjusted while the motor is running.

3.7.3 5-1* Digital Inputs

Parameters for configuring the input functions for the input terminals.

The digital inputs are used for selecting various functions in the adjustable frequency drive. All digital inputs can be set to the following functions:

Digital input function	Select	Terminal
No operation	[0]	All *term 32, 33
Reset	[1]	All
Coast inverse	[2]	All *term 27
Coast and reset inverse	[3]	All
Quick stop inverse	[4]	All
DC brake inverse	[5]	All
Stop inverse	[6]	All
Start	[8]	All *term 18
Latched start	[9]	All
Reversing	[10]	All *term 19
Start reversing	[11]	All
Enable start forward	[12]	All
Enable start reverse	[13]	All
Jog	[14]	All *term 29
Preset reference on	[15]	All
Preset ref bit 0	[16]	All
Preset ref bit 1	[17]	All
Preset ref bit 2	[18]	All
Freeze reference	[19]	All
Freeze output	[20]	All
Speed up	[21]	All
Slow	[22]	All
Set-up select bit 0	[23]	All
Set-up select bit 1	[24]	All
Precise stop inverse	[26]	18, 19
Precise start, stop	[27]	18, 19
Catch up	[28]	All
Slow-down	[29]	All
Counter input	[30]	29, 33
Pulse input	[32]	29, 33
Ramp bit 0	[34]	All
Ramp bit 1	[35]	All
Line failure inverse	[36]	All
Latched precise start	[40]	18, 19
Latched precise stop inverse	[41]	18, 19
DigiPot Increase	[55]	All
DigiPot Decrease	[56]	All
DigiPot Clear	[57]	All
Counter A (up)	[60]	29, 33
Counter A (down)	[61]	29, 33
Reset Counter A	[62]	All
Counter B (up)	[63]	29, 33
Counter B (down)	[64]	29, 33
Reset Counter B	[65]	All
Mech. Brake Feedb.	[70]	All
Mech. Brake Feedb. Inv.	[71]	All
PID enable	[74]	
MCO Specific	[75]	
PTC Card 1	[80]	All

FC 300 standard terminals are 18, 19, 27, 29, 32 and 33. MCB 101 terminals are X30/2, X30/3 and X30/4.

Terminal 29 functions as an output only in the FC 302.

Functions dedicated to only one digital input are stated in the associated parameter.

All digital inputs can be programmed to these functions:

[0]	No operation	No reaction to signals transmitted to the terminal.
[1]	Reset	Resets adjustable frequency drive after a TRIP/ALARM. Not all alarms can be reset.
[2]	Coast inverse	(Default Digital input 27): Coasting stop, inverted input (NC). The adjustable frequency drive leaves the motor in free mode. Logic '0' => coasting stop.

[3]	Coast and reset inverse	Reset and coasting stop Inverted input (NC). Leaves the motor in free mode and resets the adjustable frequency drive. Logic '0' => coasting stop and reset.
[4]	Quick stop inverse	Inverted input (NC). Generates a stop in accordance with the quick-stop ramp time set in par. 3-81 <i>Quick Stop Ramp Time</i> . When motor stops, the shaft is in free mode. Logic '0' => quick stop.
[5]	DC brake inverse	Inverted input for DC braking (NC). Stops motor by energizing it with a DC current for a certain time period. See par. 2-01 <i>DC Brake Current</i> to par. 2-03 <i>DC Brake Cut-in Speed [RPM]</i> . The function is only active when the value in par. 2-02 <i>DC Braking Time</i> is different from 0. Logic '0' => DC braking.
[6]	Stop inverse	Stop Inverted function. Generates a stop function when the selected terminal goes from logical level '1' to '0'. The stop is performed according to the selected ramp time (par. 3-42 <i>Ramp 1 Ramp-down Time</i> , par. 3-52 <i>Ramp 2 Ramp-down Time</i> , par. 3-62 <i>Ramp 3 Ramp-down Time</i> , par. 3-72 <i>Ramp 4 Ramp-down Time</i>).
<div style="border: 1px solid black; padding: 5px;">  <p>NOTE! When the adjustable frequency drive is at the torque limit and has received a stop command, it may not stop by itself. To ensure that the adjustable frequency drive stops, configure a digital output to <i>Torque limit & stop</i> [27] and connect this digital output to a digital input that is configured as coast.</p> </div>		
[8]	Start	(Default Digital input 18): Select start for a start/stop command. Logic '1' = start, logic '0' = stop.
[9]	Latched start	The motor starts, if a pulse is applied for min. 2 ms. The motor stops when Stop inverse is activated.
[10]	Reversing	(Default Digital input 19). Change the direction of motor shaft rotation. Select Logic '1' to reverse. The reversing signal only changes the direction of rotation. It does not activate the start function. Select both directions in par. 4-10 <i>Motor Speed Direction</i> . The function is not active in process closed-loop.
[11]	Start reversing	Used for start/stop and for reversing on the same wire. Signals on start are not allowed at the same time.
[12]	Enable start forward	Disengages the counter-clockwise movement and allows for the clockwise direction.
[13]	Enable start reverse	Disengages the clockwise movement and allows for the counter-clockwise direction.
[14]	Jog	(Default Digital input 29): Use to activate jog speed. See par. 3-11 <i>Jog Speed [Hz]</i> .
[15]	Preset reference on	Shifts between external reference and preset reference. It is assumed that <i>External/preset</i> [1] has been selected in par. 3-04 <i>Reference Function</i> . Logic '0' = external reference active; logic '1' = one of the eight preset references is active.
[16]	Preset ref bit 0	Preset ref. bit 0,1, and 2 enables a choice between one of the eight preset references according to the table below.
[17]	Preset ref bit 1	Same as Preset ref bit 0 [16].
[18]	Preset ref bit 2	Same as Preset ref bit 0 [16].

Preset ref. bit	2	1	0
Preset ref. 0	0	0	0
Preset ref. 1	0	0	1
Preset ref. 2	0	1	0
Preset ref. 3	0	1	1
Preset ref. 4	1	0	0
Preset ref. 5	1	0	1
Preset ref. 6	1	1	0
Preset ref. 7	1	1	1

[19]	Freeze ref	Freezes the actual reference, which is now the point of enable/condition for Speed up and Slow to be used. If Speed up/down is used, the speed change always follows ramp 2 (par. 3-51 <i>Ramp 2</i>)
------	------------	--

Ramp-up Time and par. 3-52 Ramp 2 Ramp-down Time) in the range 0 - par. 3-03 Maximum Reference.

[20] Freeze output
Freezes the actual motor frequency (Hz), which is now the point of enable/condition for Speed up and Slow to be used. If Speed up/down is used, the speed change always follows ramp 2 (par. 3-51 Ramp 2 Ramp-up Time and par. 3-52 Ramp 2 Ramp-down Time) in the range 0 - par. 1-23 Motor Frequency.



NOTE!
When freeze output is active, the adjustable frequency drive cannot be stopped via a low 'start [8]' signal. Stop the adjustable frequency drive via a terminal programmed for Coast inverse [2] or Coast and reset inv.

[21] Speed up
Select Speed up and Slow if digital control of the up/down speed is desired (motor potentiometer). Activate this function by selecting either Freeze reference or Freeze output. When Speed up/down is activated for less than 400 msec, the resulting reference will be increased/decreased by 0.1%. If Speed up/down is activated for more than 400 msec, the resulting reference will follow the setting in ramping up/down parameter 3-x1/ 3-x2.

	Shut down	Catch up
Unchanged speed	0	0
Reduced by %-value	1	0
Increased by %-value	0	1
Reduced by %-value	1	1

[22] Slow
Same as Speed up [21].

[23] Set-up select bit 0
Select Set-up select bit 0 or Select Set-up select bit 1 to select one of the four set-ups. Set par. 0-10 Active Set-up to Multi Set-up.

[24] Set-up select bit 1
(Default Digital input 32): Same as Set-up select bit 0 [23].

[26] Precise stop inv.
Prolongs stop signal to give a precise stop independent of speed.
Sends an inverted stop signal when the precise stop function is activated in par. 1-83 Precise Stop Function.
Precise stop inverse function is available for terminals 18 or 19.

[27] Precise start, stop
Use when Precise ramp stop [0] is selected in par 1-83.

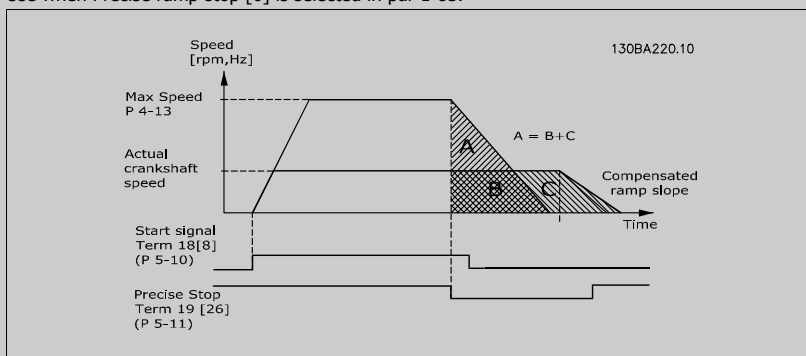

[28] Catch up
Increases reference value by percentage (relative) set in par. 3-12 Catch up/slow-down Value.

[29] Slow-down
Reduces reference value by percentage (relative) set in par. 3-12 Catch up/slow-down Value.

[30] Counter input
Precise stop function in par. 1-83 Precise Stop Function acts as counter stop or speed compensated counter stop with or without reset. The counter value must be set in par. 1-84 Precise Stop Counter Value.

[32] Pulse input
Use pulse sequence as either reference or feedback. Scaling is done in par. group 5-5*.

[34] Ramp bit 0
Enables a choice between one of the four ramps available, according to the table below.

[35]	Ramp bit 1	Same as Ramp bit 0.															
<table border="1"> <tr> <td>Preset ramp bit</td> <td>1</td> <td>0</td> </tr> <tr> <td>Ramp 1</td> <td>0</td> <td>0</td> </tr> <tr> <td>Ramp 2</td> <td>0</td> <td>1</td> </tr> <tr> <td>Ramp 3</td> <td>1</td> <td>0</td> </tr> <tr> <td>Ramp 4</td> <td>1</td> <td>1</td> </tr> </table>			Preset ramp bit	1	0	Ramp 1	0	0	Ramp 2	0	1	Ramp 3	1	0	Ramp 4	1	1
Preset ramp bit	1	0															
Ramp 1	0	0															
Ramp 2	0	1															
Ramp 3	1	0															
Ramp 4	1	1															
[36]	Line failure inverse	Activates par. 14-10 <i>Line Failure</i> . Line failure inverse is active in the logic "0" situation.															
[41]	Latched Precise Stop inverse	Sends a latched stop signal when the precise stop function is activated in par. 1-83 <i>Precise Stop Function</i> . The latched precise stop inverse function is available for terminals 18 or 19.															
[55]	DigiPot Increase	INCREASE signal to the digital potentiometer function described in par. group 3-9*															
[56]	DigiPot Decrease	DECREASE signal to the digital potentiometer function described in par. group 3-9*															
[57]	DigiPot Clear	Clears the digital potentiometer reference described in par. group 3-9*															
[60]	Counter A	(Terminal 29 or 33 only) Input for increment counting in the SLC counter.															
[61]	Counter A	(Terminal 29 or 33 only) Input for decrement counting in the SLC counter.															
[62]	Reset Counter A	Input for reset of counter A.															
[63]	Counter B	(Terminal 29 or 33 only) Input for increment counting in the SLC counter.															
[64]	Counter B	(Terminal 29 or 33 only) Input for decrement counting in the SLC counter.															
[65]	Reset Counter B	Input for reset of counter B.															
[70]	Mech. Brake Feedback	Brake feedback for hoisting applications: Set par 1-01 to [3] <i>flux w/ motor feedback</i> ; set par 1-72 to [6] <i>Hoist mech brake Ref</i> .															
[71]	Mech. Brake Feedback inv.	Inverted brake feedback for hoisting applications															
[74]	PID enable																
[75]	MCO Specific																
[80]	PTC Card 1	All digital inputs can be set to PTC card 1 [80]. However, only one digital input must be set to this choice.															

5-10 Terminal 18 Digital Input

Option: [8] * Start
Function: Functions are described under 5-1* *Digital Inputs*

5-11 Terminal 19 Digital Input

Option: [10] * Reversing
Function: Functions are described under 5-1* *Digital Inputs*

5-12 Terminal 27 Digital Input

Option: [2] * Coast inverse
Function: Functions are described under 5-1* *Digital Inputs*

5-13 Terminal 29 Digital Input

Option: [14] * Jog
Function: Select the function from the available digital input range and the additional options [60], [61], [63] and [64]. Counters are used in Smart Logic Control functions. This parameter is available for the FC 302 only.
 Functions are described under 5-1* *Digital Inputs*

5-14 Terminal 32 Digital Input

Option:

[0] * No operation

Function:

Select the function from the available digital input range and the additional options [60], [61], [63] and [64]. Counters are used in Smart Logic Control functions.

Functions are described under 5-1* *Digital Inputs*

5-15 Terminal 33 Digital Input

Option:

[0] * No operation

Function:

Select the function from the available digital input range and the additional options [60], [61], [63] and [64]. Counters are used in Smart Logic Control functions.

Functions are described under 5-1* *Digital Inputs*

5-16 Terminal X30/2 Digital Input

Option:

[0] * No operation

Function:

This parameter is active when option module MCB101 is installed in the adjustable frequency drive. Functions are described under 5-1* *Digital Inputs*

5-17 Terminal X30/3 Digital Input

Option:

[0] * No operation

Function:

This parameter is active when option module MCB101 is installed in the adjustable frequency drive. Functions are described under 5-1* *Digital Inputs*

5-18 Terminal X30/4 Digital Input

Option:

[0] * No operation

Function:

This parameter is active when option module MCB101 is installed in the adjustable frequency drive. Functions are described under 5-1* *Digital Inputs*

5-19 Terminal 37 Safe Stop

Option:

[1] * Safe Stop Alarm

Function:

Coasts adjustable frequency drive when safe stop is activated. Manual reset from LCP, digital input or serial communication bus.

[3] Safe Stop Warning

Coasts adjustable frequency drive when safe stop is activated (T-37 off). When the safe stop circuit is reestablished, the adjustable frequency drive will continue without manual reset.

[4] PTC 1 Alarm

Coasts adjustable frequency drive when safe stop is activated. Manual reset from LCP, digital input or serial communication bus. Choice 4 is only available when the MCB 112 PTC thermistor card is connected.

[5] PTC 1 Warning

Coasts adjustable frequency drive when safe stop is activated (T-37 off). When the safe stop circuit is reestablished, the adjustable frequency drive will continue without manual reset, unless a digital input set to PTC Card 1 [80] is still enabled. Choice 5 is only available when the MCB 112 PTC thermistor card is connected.

[6] PTC 1 & Relay A

This choice is used when the PTC option is gated together with a stop button through a safety relay to T-37. Coasts adjustable frequency drive when safe stop is activated. Manual reset from LCP, digital input or serial communication bus. Choice 6 is only available when the MCB 112 PTC thermistor card is connected.

[7] PTC 1 & Relay W

This choice is used when the PTC option is gated together with a stop button through a safety relay to T-37. Coasts adjustable frequency drive when safe stop is activated (T-37 off). When the safe stop circuit is reestablished, the adjustable frequency drive will continue without manual reset, unless a digital input set to PTC Card 1 [80] is (still) enabled. Choice 7 is only available when the MCB 112 PTC thermistor card is connected.

[8]	PTC 1 & Relay A/W	This choice makes it possible to use a combination of alarm and warning. Choice 8 is only available when the MCB 112 PTC thermistor card is connected.
[9]	PTC 1 & Relay W/A	This choice makes it possible to use a combination of alarm and warning. Choice 9 is only available when the MCB 112 PTC thermistor card is connected.

Choices 4–9 are only available when the MCB 112 PTC thermistor card is connected.

NOTE!
When Auto Reset/ Warning is selected, the adjustable frequency drive opens up for automatic restart.

Overview of functions, alarms and warnings

Function	No.	PTC	Relay
No Function	[0]	-	-
Safe Stop Alarm	[1]*	-	Safe Stop [A68]
Safe Stop Warning	[3]	-	Safe Stop [W68]
PTC 1 Alarm	[4]	PTC 1 Safe Stop [A71]	-
PTC 1 Warning	[5]	PTC 1 Safe Stop [W71]	-
PTC 1 & Relay A	[6]	PTC 1 Safe Stop [A71]	Safe Stop [A68]
PTC 1 & Relay W	[7]	PTC 1 Safe Stop [W71]	Safe Stop [W68]
PTC 1 & Relay A/W	[8]	PTC 1 Safe Stop [A71]	Safe Stop [W68]
PTC 1 & Relay W/A	[9]	PTC 1 Safe Stop [W71]	Safe Stop [A68]

W means warning, and A means alarm. For further information, see Alarms and Warnings in section *Troubleshooting* in the Design Guide or in the Instruction Manual.

A dangerous failure related to safe stop will issue the alarm: Dangerous Failure [A72].

Please refer to the section *Description of Alarm Word, Warning Word and extended Status Word* in the chapter *Troubleshooting*.

5-20 Terminal X46/1 Digital Input

Option:	Function:
[0] * No operation	This parameter is active when option module MCB 113 is installed in the adjustable frequency drive. Functions are described under 5-1* <i>Digital Inputs</i>

5-21 Terminal X46/3 Digital Input

Option:	Function:
[0] * No operation	This parameter is active when option module MCB 113 is installed in the adjustable frequency drive. Functions are described under 5-1* <i>Digital Inputs</i>

5-22 Terminal X46/5 Digital Input

Option:	Function:
[0] * No operation	This parameter is active when option module MCB 113 is installed in the adjustable frequency drive. Functions are described under 5-1* <i>Digital Inputs</i>

5-23 Terminal X46/7 Digital Input

Option:	Function:
[0] * No operation	This parameter is active when option module MCB 113 is installed in the adjustable frequency drive. Functions are described under 5-1* <i>Digital Inputs</i>

5-24 Terminal X46/9 Digital Input

Option:	Function:
[0] * No operation	This parameter is active when option module MCB 113 is installed in the adjustable frequency drive. Functions are described under 5-1* <i>Digital Inputs</i>

5-25 Terminal X46/11 Digital Input

Option:

[0] * No operation

Function:

 This parameter is active when option module MCB 113 is installed in the adjustable frequency drive. Functions are described under 5-1* *Digital Inputs*

5-26 Terminal X46/13 Digital Input

Option:

[0] * No operation

Function:

 This parameter is active when option module MCB 113 is installed in the adjustable frequency drive. Functions are described under 5-1* *Digital Inputs*

3.7.4 5-3* Digital Outputs

Parameters for configuring the output functions for the output terminals. The 2 solid-state digital outputs are common for terminals 27 and 29. Set the I/O function for terminal 27 in par. 5-01 *Terminal 27 Mode*, and set the I/O function for terminal 29 in par. 5-02 *Terminal 29 Mode*. These parameters cannot be adjusted while the motor is running.

[0]	No operation	<i>Default for all digital outputs and relay outputs</i>
[1]	Control ready	The control board receives supply voltage.
[2]	Drive ready	The adjustable frequency drive is ready for operation and applies a supply signal on the control board.
[3]	Drive ready / remote control	The adjustable frequency drive is ready for operation and is in Auto On mode.
[4]	Enable / no warning	Ready for operation. No start or stop command is been given (start/disable). There are no warnings.
[5]	VLT running	Motor is running.
[6]	Running / no warning	Output speed is higher than the speed set in par. 1-81 <i>Min Speed for Function at Stop [RPM]</i> . The motor is running and there are no warnings.
[7]	Run in range/no warning	Motor is running within the programmed current and speed ranges set in par. 4-50 <i>Warning Current Low</i> to par. 4-53 <i>Warning Speed High</i> . There are no warnings.
[8]	Run on reference / no warning	Motor runs at reference speed.
[9]	Alarm	An alarm activates the output. There are no warnings.
[10]	Alarm or warning	An alarm or a warning activates the output.
[11]	At torque limit	The torque limit set in par. 4-16 <i>Torque Limit Motor Mode</i> or par. 1-17 has been exceeded.
[12]	Out of current range	The motor current is outside the range set in par. 4-18 <i>Current Limit</i> .
[13]	Below current, low	Motor current is lower than set in par. 4-50 <i>Warning Current Low</i> .
[14]	Above current, high	Motor current is higher than set in par. 4-51 <i>Warning Current High</i> .
[15]	Out of speed range	Output frequency is outside the frequency ranges set in par. 4-50 <i>Warning Current Low</i> and par. 4-51 <i>Warning Current High</i> .
[16]	Below speed, low	Output speed is lower than the setting in par. 4-52 <i>Warning Speed Low</i> .
[17]	Above speed, high	Output speed is higher than the setting in par. 4-53 <i>Warning Speed High</i> .
[18]	Out of feedback range	Feedback is outside the range set in par. 4-56 <i>Warning Feedback Low</i> and par. 4-57 <i>Warning Feedback High</i> .
[19]	Below feedback low	Feedback is below the limit set in par. 4-56 <i>Warning Feedback Low</i> .
[20]	Above feedback high	Feedback is above the limit set in par. 4-57 <i>Warning Feedback High</i> .
[21]	Thermal warning	The thermal warning turns on when the temperature exceeds the limit in the motor, the adjustable frequency drive, the brake resistor, or the thermistor.
[22]	Ready, no thermal warning	The adjustable frequency drive is ready for operation and there is no overtemperature warning.

[23]	Remote, ready, no thermal warning	The adjustable frequency drive is ready for operation and is in auto on mode. There is no overtemperature warning.
[24]	Ready, no over/undervoltage	The adjustable frequency drive is ready for operation, and the AC line voltage is within the specified voltage range (see <i>General Specifications</i> section).
[25]	Reverse	<i>Reversing. Logic '1'</i> when CW rotation of the motor. Logic '0' when CCW rotation of the motor. If the motor is not rotating, the output will follow the reference.
[26]	Bus OK	Active communication (no timeout) via the serial communication port.
[27]	Torque limit and stop	Use in performing a coasting stop and in torque limit condition. If the adjustable frequency drive has received a stop signal and is at the torque limit, the signal is Logic '0'.
[28]	Brake, no brake warning	Brake is active and there are no warnings.
[29]	Brake ready, no fault	Brake is ready for operation and there are no faults.
[30]	Brake fault (IGBT)	Output is Logic '1' when the brake IGBT is short-circuited. Use this function to protect the adjustable frequency drive if there is a fault on the brake modules. Use the output/relay to cut out the main voltage from the adjustable frequency drive.
[31]	Relay 123	The relay is activated when Control Word [0] is selected in parameter group 8-**.
[32]	Mechanical brake control	Enables control of an external mechanical brake; see description in the section <i>Control of Mechanical Brake</i> , and par. group 2-2*.
[33]	Safe stop activated (FC 302 only)	Indicates that the safe stop on terminal 37 has been activated.
[40]	Out of ref range	
[41]	Below reference low	
[42]	Above reference high	
[45]	Bus Ctrl	Controls output via bus. The state of the output is set in par. 5-90 <i>Digital & Relay Bus Control</i> . The output state is retained in the event of bus timeout.
[46]	Bus Ctrl On at timeout	Controls output via bus. The state of the output is set in par. 5-90 <i>Digital & Relay Bus Control</i> . In the event of a bus timeout, the output state is set high (On).
[47]	Bus Ctrl Off at timeout	Controls output via bus. The state of the output is set in par. 5-90 <i>Digital & Relay Bus Control</i> . In the event of a bus timeout, the output state is set low (Off).
[51]	MCO controlled	
[55]	Pulse output	
[60]	Comparator 0	See par. group 13-1*. If Comparator 0 is evaluated as TRUE, the output will go high. Otherwise, it will be low.
[61]	Comparator 1	See par. group 13-1*. If Comparator 1 is evaluated as TRUE, the output will go high. Otherwise, it will be low.
[62]	Comparator 2	See par. group 13-1*. If Comparator 2 is evaluated as TRUE, the output will go high. Otherwise, it will be low.
[63]	Comparator 3	See par. group 13-1*. If Comparator 3 is evaluated as TRUE, the output will go high. Otherwise, it will be low.
[64]	Comparator 4	See par. group 13-1*. If Comparator 4 is evaluated as TRUE, the output will go high. Otherwise, it will be low.
[65]	Comparator 5	See par. group 13-1*. If Comparator 5 is evaluated as TRUE, the output will go high. Otherwise, it will be low.
[70]	Logic Rule 0	See par. group 13-4*. If Logic Rule 0 is evaluated as TRUE, the output will go high. Otherwise, it will be low.
[71]	Logic Rule 1	See par. group 13-4*. If Logic Rule 1 is evaluated as TRUE, the output will go high. Otherwise, it will be low.
[72]	Logic Rule 2	See par. group 13-4*. If Logic Rule 2 is evaluated as TRUE, the output will go high. Otherwise, it will be low.

[73]	Logic Rule 3	See par. group 13-4*. If Logic Rule 3 is evaluated as TRUE, the output will go high. Otherwise, it will be low.
[74]	Logic Rule 4	See par. group 13-4*. If Logic Rule 4 is evaluated as TRUE, the output will go high. Otherwise, it will be low.
[75]	Logic Rule 5	See par. group 13-4*. If Logic Rule 5 is evaluated as TRUE, the output will go high. Otherwise, it will be low.
[80]	SL Digital Output A	See par. 13-52 <i>SL Controller Action</i> . The output will go high whenever the Smart Logic Action [38] <i>Set dig. out. A high</i> is executed. The output will go low whenever the Smart Logic Action [32] <i>Set dig. out. A low</i> is executed.
[81]	SL Digital Output B	See par. 13-52 <i>SL Controller Action</i> . The input will go high whenever the Smart Logic Action [39] <i>Set dig. out. A high</i> is executed. The input will go low whenever the Smart Logic Action [33] <i>Set dig. out. A low</i> is executed.
[82]	SL Digital Output C	See par. 13-52 <i>SL Controller Action</i> . The input will go high whenever the Smart Logic Action [40] <i>Set dig. out. A high</i> is executed. The input will go low whenever the Smart Logic Action [34] <i>Set dig. out. A low</i> is executed.
[83]	SL Digital Output D	See par. 13-52 <i>SL Controller Action</i> . The input will go high whenever the Smart Logic Action [41] <i>Set dig. out. A high</i> is executed. The input will go low whenever the Smart Logic Action [35] <i>Set dig. out. A low</i> is executed.
[84]	SL Digital Output E	See par. 13-52 <i>SL Controller Action</i> . The input will go high whenever the Smart Logic Action [42] <i>Set dig. out. A high</i> is executed. The input will go low whenever the Smart Logic Action [36] <i>Set dig. out. A low</i> is executed.
[85]	SL Digital Output F	See par. 13-52 <i>SL Controller Action</i> . The input will go high whenever the Smart Logic Action [43] <i>Set dig. out. A high</i> is executed. The input will go low whenever the Smart Logic Action [37] <i>Set dig. out. A low</i> is executed.
[120]	Local reference active	Output is high when par. 3-13 <i>Reference Site</i> = [2] <i>Local</i> or when par. 3-13 <i>Reference Site</i> = [0] <i>Linked to hand auto</i> at the same time as the LCP is in hand on mode.
[121]	Remote reference active	Output is high when par. 3-13 <i>Reference Site</i> = <i>Remote</i> [1] or <i>Linked to hand/auto</i> [0] while the LCP is in [Auto on] mode.
[122]	No alarm	Output is high when no alarm is present.
[123]	Start command active	Output is high when there is an active start command (i.e., via digital input bus connection or [Hand on] or [Auto on]), and no stop or start command is active.
[124]	Running reverse	Output is high when the adjustable frequency drive is running counter clockwise (the logical product of the status bits 'running' AND 'reverse').
[125]	Drive in hand mode	Output is high when the adjustable frequency drive is in hand on mode (as indicated by the LED light above [Hand on]).
[126]	Drive in auto mode	Output is high when the adjustable frequency drive is in hand on mode (as indicated by the LED light above [Auto on]).

5-30 Terminal 27 Digital Output

Option:

[0] * No operation

Function:

 Functions are described under 5-3* *Digital Outputs*

5-31 Terminal 29 Digital Output

Option:

[0] * No operation

Function:

 Functions are described under 5-3* *Digital Outputs*

This parameter only applies to the FC 302

5-32 Term X30/6 Digi Out (MCB 101)

Option:

[0] * No operation

Function:

This parameter is active when option module MCB 101 is mounted in the adjustable frequency drive. Functions are described under 5-3* *Digital Outputs*

5-33 Term X30/7 Digi Out (MCB 101)

Option:

[0] * No operation

Function:

This parameter is active when option module MCB 101 is mounted in the adjustable frequency drive. Functions are described under 5-3* *Digital Outputs*

3.7.5 5-4* Relays

Parameters for configuring the timing and the output functions for the relays.

5-40 Function Relay

Array [9]

(Relay 1 [0], Relay 2 [1], Relay 3 [2] (MCB 113), Relay 4 [3] (MCB 113), Relay 5 [4] (MCB 113), Relay 6 [5] (MCB 113), Relay 7 [6] (MCB 105), Relay 8 [7] (MCB 105), Relay 9 [8] (MCB 105))

Option:

Function:

[0] * No operation

[1] Control ready

[2] Drive ready

[3] Drive rdy/rem ctrl

[4] Enable / no warning

[5] VLT running

[6] Running / no warning

[7] Run in range/no warn

[8] Run on ref/no warn

[9] Alarm

[10] Alarm or warning

[11] At torque limit

[12] Out of current range

[13] Below current, low

[14] Above current, high

[15] Out of speed range

[16] Below speed, low

[17] Above speed, high

[18] Out of feedb. range

[19] Below feedback, low

[20] Above feedback, high

[21] Thermal warning

[22] Ready,no thermal W

[23] Remote,ready,no TW

[24] Ready, voltage OK

[25] Reverse

[26]	Bus OK
[27]	Torque limit stop
[28]	Brake: No Brake War
[29]	Brake ready, no fault
[30]	Brake fault (IGBT)
[31]	Relay 123
[32]	Mech brake ctrl
[33]	Safe stop active
[36]	Control word bit 11
[37]	Control word bit 12
[38]	Motor feedback error
[39]	Tracking error
[40]	Out of ref range
[41]	Below reference, low
[42]	Above ref, high
[43]	Extended PID Limit
[45]	Bus ctrl.
[46]	Bus ctrl, 1 if timeout
[47]	Bus ctrl, 0 if timeout
[51]	MCO controlled
[60]	Comparator 0
[61]	Comparator 1
[62]	Comparator 2
[63]	Comparator 3
[64]	Comparator 4
[65]	Comparator 5
[70]	Logic rule 0
[71]	Logic rule 1
[72]	Logic rule 2
[73]	Logic rule 3
[74]	Logic rule 4
[75]	Logic rule 5
[80]	SL digital output A
[81]	SL digital output B
[82]	SL digital output C
[83]	SL digital output D
[84]	SL digital output E
[85]	SL digital output F
[120]	Local ref active
[121]	Remote ref active
[122]	No alarm
[123]	Start command activ
[124]	Running reverse

[125] Drive in hand mode

[126] Drive in auto mode

5-41 On Delay, Relay

Array [8](Relay 1 [0], Relay 2 [1], Relay 3 [2], Relay 4 [3], Relay 5 [4], Relay 6 [5], Relay 7 [6], Relay 8 [7], Relay 9 [8])

Range:

0.01 s* [0.01 - 600.00 s]

Function:

Enter the delay of the relay cut-in time. Select one of available mechanical relays and MCB 105 in an array function. See par. 5-40 *Function Relay*. Relay 3-6 are included in MCB 113.

3

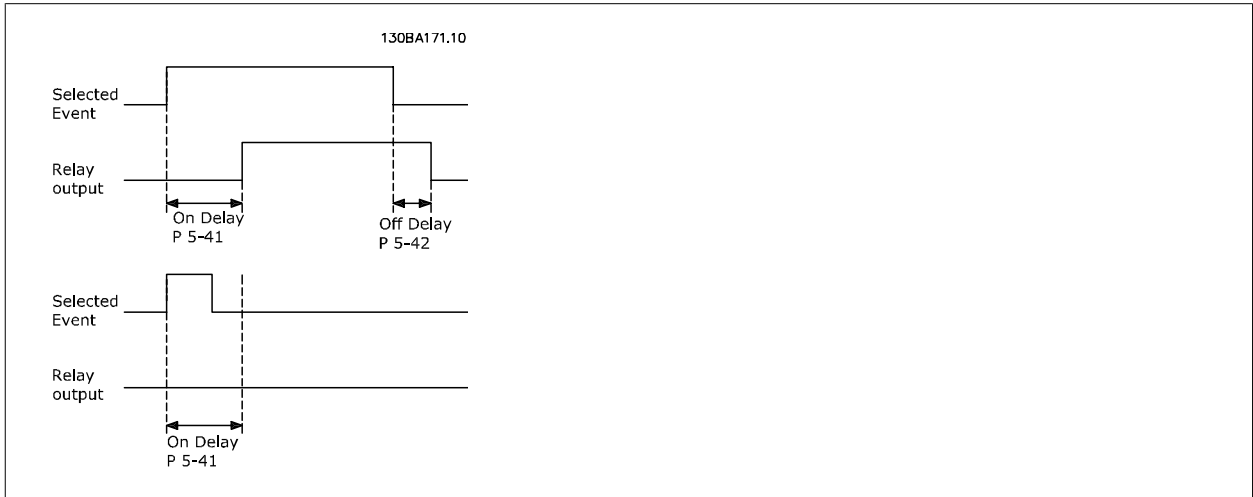

5-42 Off Delay, Relay

Array [8] (Relay 1 [0], Relay 2 [1], Relay 3 [2], Relay 4 [3], Relay 5 [4], Relay 6 [5], Relay 7 [6], Relay 8 [7], Relay 9 [8])

Range:

0.01 s* [0.01 - 600.00 s]

Function:

Enter the delay of the relay cut-out time. Select one of available mechanical relays and MCB 105 in an array function. See par. 5-40 *Function Relay*.

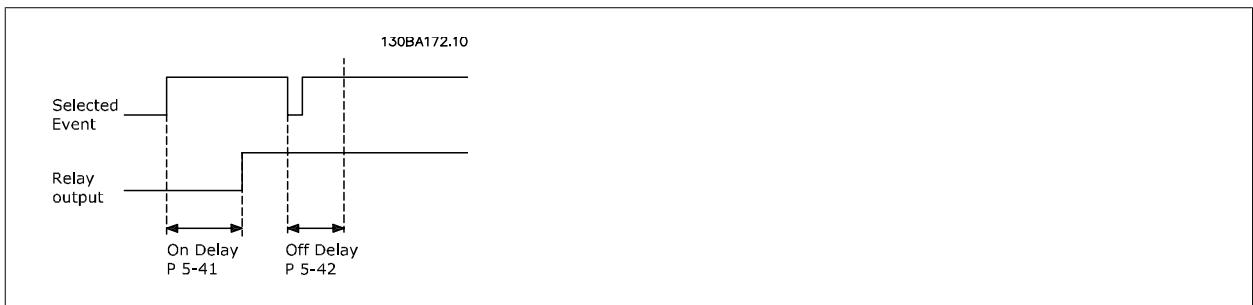

If the selected event condition changes before the on or off delay timer expires, the relay output is unaffected.

3.7.6 5-5* Pulse Input

The pulse input parameters are used to define an appropriate window for the impulse reference area by configuring the scaling and filter settings for the pulse inputs. Input terminals 29 or 33 act as frequency reference inputs. Set terminal 29 (par. 5-13 *Terminal 29 Digital Input*) or terminal 33 (par. 5-15 *Terminal 33 Digital Input*) to *Pulse input* [32]. If terminal 29 is used as an input, then set par. 5-01 *Terminal 27 Mode* to *Input* [0].

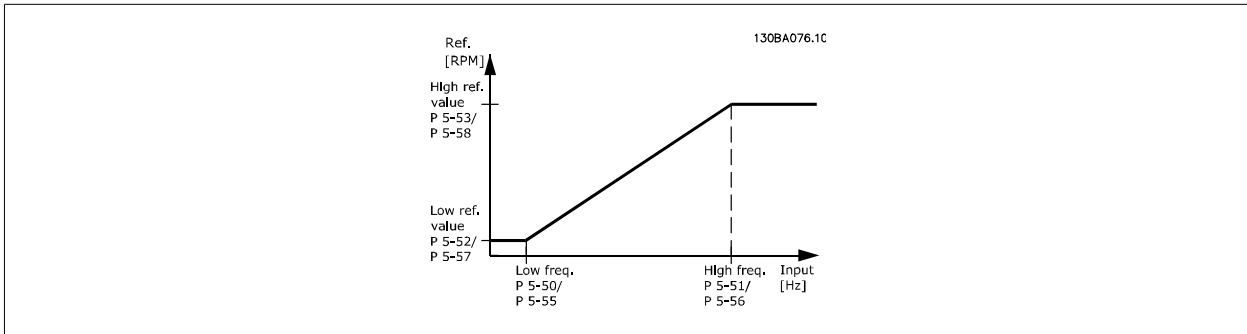

5-50 Term. 29 Low Frequency

Range:

100 Hz* [0 - 110000 Hz]

Function:

Enter the low frequency limit corresponding to the low motor shaft speed (i.e., low reference value) in par. 5-52 *Term. 29 Low Ref./Feedb. Value*. Refer to the diagram in this section. This parameter is available for the FC 302 only.

5-51 Term. 29 High Frequency

Range:

100 Hz* [0 - 110000 Hz]

Function:

Enter the high frequency limit corresponding to the high motor shaft speed (i.e., high reference value) in par. 5-53 *Term. 29 High Ref./Feedb. Value*. This parameter is available for the FC 302 only.

5-52 Term. 29 Low Ref./Feedb. Value

Range:

0.000 Ref- [-999999.999 - 999999.999 ReferenceFeed-enceFeedbackUnit] backUnit*

Function:

Enter the low reference value limit for the motor shaft speed [RPM]. This is also the lowest feedback value, see also par. 5-57 *Term. 33 Low Ref./Feedb. Value*. Set terminal 29 to digital input (par. 5-02 *Terminal 29 Mode = input* [0] (default) and par. 5-13 *Terminal 29 Digital Input = applicable value*). This parameter is available for the FC 302 only.

5-53 Term. 29 High Ref./Feedb. Value

Range:

Application [-999999.999 - 999999.999 ReferenceFeed-enceFeedbackUnit]

Function:

Enter the high reference value [RPM] for the motor shaft speed and the high feedback value, see also par. 5-58 *Term. 33 High Ref./Feedb. Value*. Select terminal 29 as a digital input (par. 5-02 *Terminal 29 Mode = input* [0] (default) and par. 5-13 *Terminal 29 Digital Input = applicable value*). This parameter is available for the FC 302 only.

5-54 Pulse Filter Time Constant #29

Range:

100 ms* [1 - 1000 ms]

Function:

Enter the pulse filter time constant. The pulse filter dampens oscillations of the feedback signal, which is an advantage if there is a lot of noise in the system. A high time constant value results in

better damping, but also increases the time delay through the filter. This parameter is available for the FC 302 only.
 This parameter cannot be adjusted while the motor is running.

5-55 Term. 33 Low Frequency

Range:	Function:
100 Hz* [0 - 110000 Hz]	Enter the low frequency corresponding to the low motor shaft speed (i.e., low reference value) in par. 5-57 <i>Term. 33 Low Ref./Feedb. Value.</i>

5-56 Term. 33 High Frequency

Range:	Function:
100 Hz* [0 - 110000 Hz]	Enter the high frequency corresponding to the high motor shaft speed (i.e., high reference value) in par. 5-58 <i>Term. 33 High Ref./Feedb. Value.</i>

5-57 Term. 33 Low Ref./Feedb. Value

Range:	Function:
0.000 N/A* [-999999.999 - 999999.999 N/A]	Enter the low reference value [RPM] for the motor shaft speed. This is also the low feedback value, see also par. 5-52 <i>Term. 29 Low Ref./Feedb. Value.</i>

5-58 Term. 33 High Ref./Feedb. Value

Range:	Function:
Application [-999999.999 - 999999.999 ReferenceFeedbackUnit]	Enter the high reference value [RPM] for the motor shaft speed. See also par. 5-53 <i>Term. 29 High Ref./Feedb. Value.</i>

5-59 Pulse Filter Time Constant #33

Range:	Function:
100 ms* [1 - 1000 ms]	Enter the pulse filter time constant. The low-pass filter reduces the influence on, and dampens oscillations in, the feedback signal from the control. This is an advantage, if, for example, there is a great amount of noise in the system. This parameter cannot be adjusted while the motor is running.

3.7.7 5-6* Pulse Outputs

These parameters are to configure pulse outputs with their functions and scaling. Terminal 27 and 29 are allocated to pulse output via par. 5-01 *Terminal 27 Mode* and par. 5-02 *Terminal 29 Mode*, respectively.

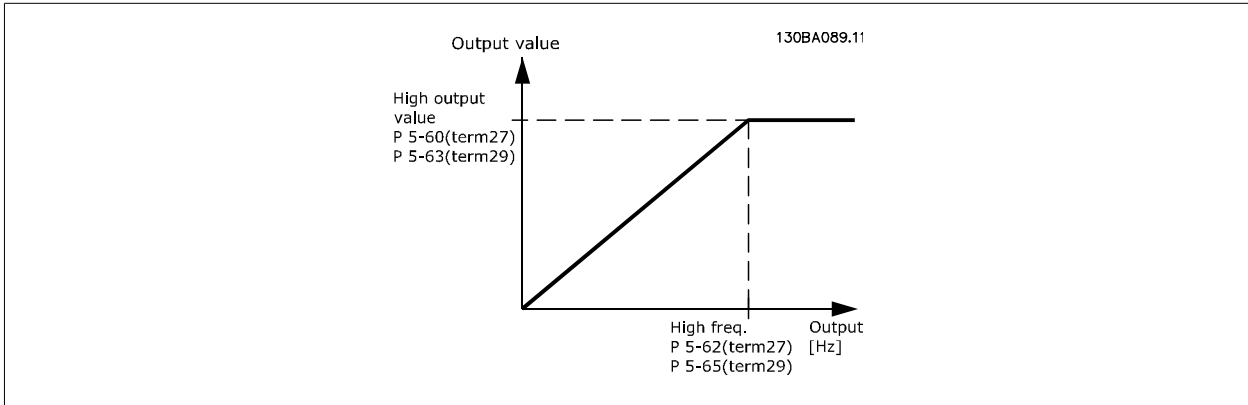

Options for readout output variables:

Parameters for configuring the scaling and output functions of pulse outputs. The pulse outputs are designated for terminals 27 or 29. Select terminal 27 output in par. 5-01 *Terminal 27 Mode* and terminal 29 output in par. 5-02 *Terminal 29 Mode*.

- [0] No operation
- [45] Bus control
- [48] Bus control timeout
- [51] MCO controlled
- [100] Output frequency
- [101] Reference
- [102] Feedback
- [103] Motor current
- [104] Torque relative to limit
- [105] Torque relative to rated
- [106] Power
- [107] Speed
- [108] Torque
- [109] Max Out Freq

5-60 Terminal 27 Pulse Output Variable

Option:

Function:

- | | | |
|-------|--------------------|---|
| [0] * | No operation | Select the desired display output for terminal 27.
This parameter cannot be adjusted while the motor is running. |
| [45] | Bus ctrl. | |
| [48] | Bus ctrl., timeout | |
| [51] | MCO controlled | |
| [100] | Output frequency | |
| [101] | Reference | |

[102]	Feedback
[103]	Motor current
[104]	Torque rel to limit
[105]	Torq relate to rated
[106]	Power
[107]	Speed
[108]	Torque
[109]	Max Out Freq
[119]	Torque % lim

5-62 Pulse Output Max Freq #27

Range:	Function:
Application [0 - 32000 Hz] dependent*	Set the maximum frequency for terminal 27, corresponding to the output variable selected in par. 5-60 <i>Terminal 27 Pulse Output Variable</i> . This parameter cannot be adjusted while the motor is running.

5-63 Terminal 29 Pulse Output Variable

Option:	Function:
[0] * No operation	Select the desired display output for terminal 29. This parameter is available for the FC 302 only. This parameter cannot be adjusted while the motor is running.
[45]	Bus ctrl.
[48]	Bus ctrl., timeout
[51]	MCO controlled
[100]	Output frequency
[101]	Reference
[102]	Feedback
[103]	Motor current
[104]	Torque rel to limit
[105]	Torq relate to rated
[106]	Power
[107]	Speed
[108]	Torque
[109]	Max Out Freq
[119]	Torque % lim

5-65 Pulse Output Max Freq #29

Set the maximum frequency for terminal 29 corresponding to the output variable set in par. 5-63 *Terminal 29 Pulse Output Variable*.
This parameter cannot be adjusted while the motor is running.

Range:	Function:
5000 Hz* [0 - 32000 Hz]	

5-66 Terminal 29 Pulse Output Variable

Select the variable for readout on terminal X30/6.
This parameter cannot be adjusted while the motor is running.
This parameter is active when option module MCB 101 is installed in the adjustable frequency drive.
Same options and functions as par. 5-6*.

Option: **Function:**

[0] * No operation

5-68 Pulse Output Max Freq #X30/6

Select the maximum frequency on terminal X30/6 referring to the output variable in par. 5-66 *Terminal X30/6 Pulse Output Variable*. This parameter cannot be adjusted while the motor is running.

This parameter is active when option module MCB 101 is mounted in the adjustable frequency drive.

Range: **Function:**

Application [0 - 32000 Hz]
dependent*

3.7.8 5-7* 24 V Encoder Input

Parameters for configuring the 24 V encoder.

Connect the 24 V encoder to terminal 12 (24 V DC supply), terminal 32 (Channel A), terminal 33 (Channel B), and terminal 20 (GND). The digital inputs 32/33 are active for encoder inputs when *24 V encoder* is selected in par. 1-02 *Flux Motor Feedback Source* and par. 7-00 *Speed PID Feedback Source*. The encoder used is a dual channel (A and B) 24 V type. Max input frequency: 110 kHz.

Encoder connection to the adjustable frequency drive

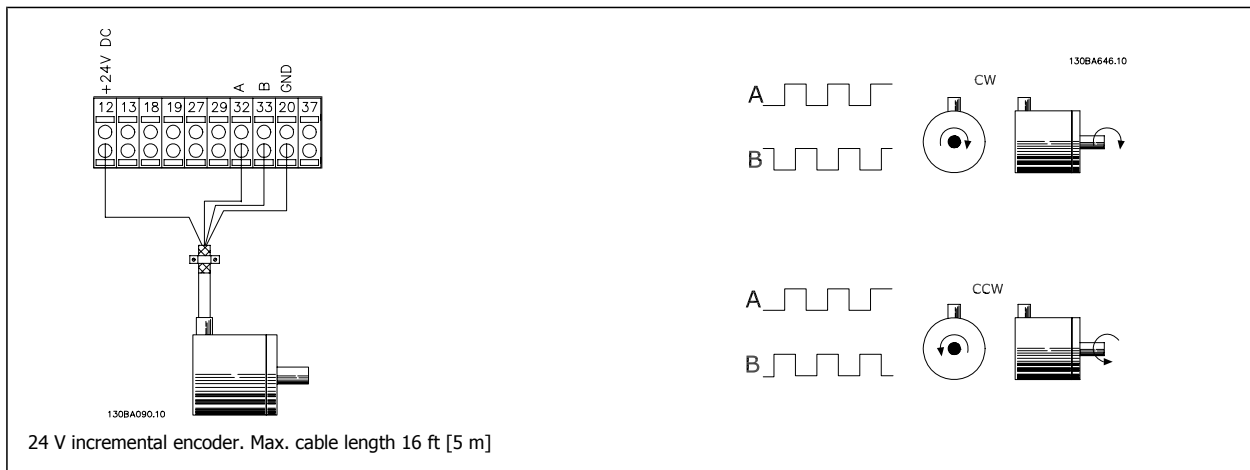

5-70 Term 32/33 Pulses per Revolution

Range: **Function:**

1024* [1 - 4096]

Set the encoder pulses per revolution on the motor shaft. Read the correct value from the encoder. This parameter cannot be adjusted while the motor is running.

5-71 Term 32/33 Encoder Direction

Option: **Function:**

Change the detected encoder rotation direction without changing the wiring to the encoder.

[0] * Clockwise

Sets channel A 90° (electrical degrees) behind channel B upon clockwise rotation of the encoder shaft.

[1] Counterclockwise

Sets channel A 90° (electrical degrees) ahead of channel B upon clockwise rotation of the encoder shaft.

This parameter cannot be adjusted while the motor is running.

3.7.9 5-9*Bus Controlled

This parameter group selects digital and relay outputs via a serial communication bus setting.

5-90 Digital & Relay Bus Control

Range:

0* [0 - 2147483647]

Function:

This parameter holds the state of the digital outputs and relays that is controlled by bus.
 A logical '1' indicates that the output is high or active.
 A logical '0' indicates that the output is low or inactive.

Bit 0	Digital Output Terminal 27
Bit 1	Digital Output Terminal 29
Bit 2	Digital Output Terminal X 30/6
Bit 3	Digital Output Terminal X 30/7
Bit 4	Relay 1 output terminal
Bit 5	Relay 2 output terminal
Bit 6	Option B Relay 1 output terminal
Bit 7	Option B Relay 2 output terminal
Bit 8	Option B Relay 3 output terminal
Bit 9-15	Reserved for future terminals
Bit 16	Option C Relay 1 output terminal
Bit 17	Option C Relay 2 output terminal
Bit 18	Option C Relay 3 output terminal
Bit 19	Option C Relay 4 output terminal
Bit 20	Option C Relay 5 output terminal
Bit 21	Option C Relay 6 output terminal
Bit 22	Option C Relay 7 output terminal
Bit 23	Option C Relay 8 output terminal
Bit 24-31	Reserved for future terminals

5-93 Pulse Out #27 Bus Control

Range:

0.00 %* [0.00 - 100.00 %]

Function:

5-94 Pulse Out #27 Timeout Preset

Range:

0.00 %* [0.00 - 100.00 %]

Function:

5-95 Pulse Out #29 Bus Control

Range:

0.00 %* [0.00 - 100.00 %]

Function:

5-96 Pulse Out #29 Timeout Preset

Range:

0.00 %* [0.00 - 100.00 %]

Function:

5-97 Pulse Out #X30/6 Bus Control

Range:

0.00 %* [0.00 - 100.00 %]

Function:

5-98 Pulse Out #X30/6 Timeout Preset

Range:

0.00 %* [0.00 - 100.00 %]

Function:

3.8 Parameters: Analog In/Out

3.8.1 6-** Analog In/Out

Parameter group for configuring the analog input and output.

3.8.2 6-0* Analog I/O Mode

The analog inputs can freely be allocated to be either voltage (FC 301: 0..10 V, FC 302: 0..+/- 10V) or current (FC 301/FC 302: 0/4..20 mA) input.



NOTE!

Thermistors may be connected to either an analog or a digital input.

6-00 Live Zero Timeout Time

Range:

10 s* [1 - 99 s]

Function:

Enter the Live Zero Timeout time period. Live Zero Timeout Time is active for analog inputs, i.e., terminal 53 or terminal 54, used as reference or feedback sources. If the reference signal value associated with the selected current input falls below 50% of the value set in par. 6-10 *Terminal 53 Low Voltage*, par. 6-12 *Terminal 53 Low Current*, par. 6-20 *Terminal 54 Low Voltage* or par. 6-22 *Terminal 54 Low Current* for a time period longer than the time set in par. 6-00 *Live Zero Timeout Time*, the function selected in par. 6-01 *Live Zero Timeout Function* will be activated.

6-01 Live Zero Timeout Function

Option:

Function:

Select the timeout function. The function set in par. 6-01 *Live Zero Timeout Function* will be activated if the input signal on terminal 53 or 54 is below 50% of the value in par. 6-10 *Terminal 53 Low Voltage*, par. 6-12 *Terminal 53 Low Current*, par. 6-20 *Terminal 54 Low Voltage* or par. 6-22 *Terminal 54 Low Current* for a time period defined in par. 6-00 *Live Zero Timeout Time*. If several timeouts occur simultaneously, the adjustable frequency drive prioritizes the timeout functions as follows:

1. Par. 6-01 *Live Zero Timeout Function*
2. Par. 5-74
3. Par. 8-04 *Control Word Timeout Function*

[0] * Off

[1] Freeze output Frozen at the present value

[2] Stop Overruled to stop

[3] Jogging Overruled to jog speed

[4] Max. speed Overruled to max. speed

[5] Stop and trip Overruled to stop with subsequent trip

[20] Coast

[21] Coast and trip

3.8.3 6-1* Analog Input 1

Parameters for configuring the scaling and limits for analog input 1 (terminal 53).

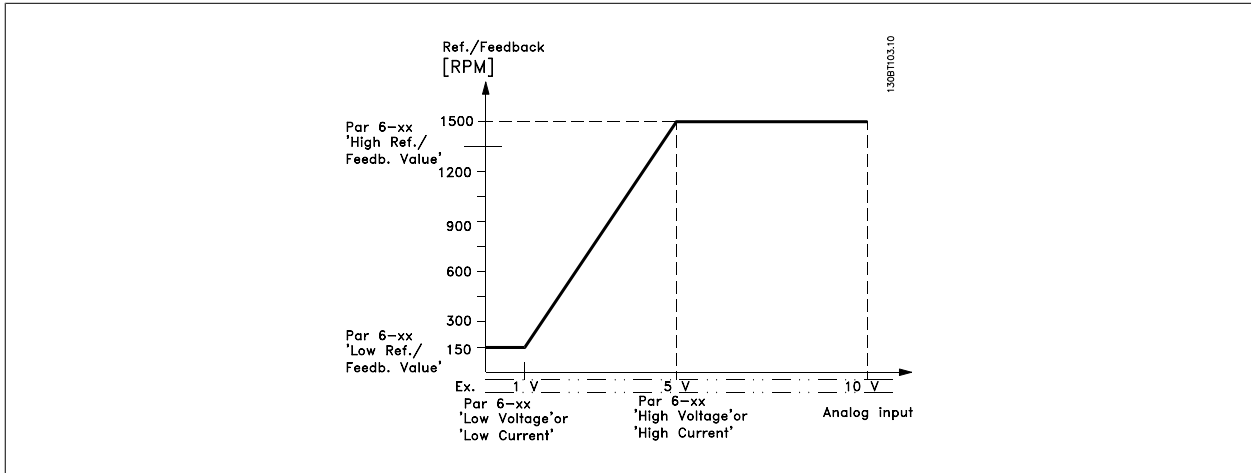

3

6-10 Terminal 53 Low Voltage

Range:

0.07 V* [Application dependant]

Function:

Enter the low voltage value. This analog input scaling value should correspond to the minimum reference value, set in par. 6-14 *Terminal 53 Low Ref./Feedb. Value*. See also the section *Reference Handling*.

6-11 Terminal 53 High Voltage

Range:

10.00 V* [Application dependant]

Function:

Enter the high voltage value. This analog input scaling value should correspond to the high reference/feedback value set in par. 6-15 *Terminal 53 High Ref./Feedb. Value*.

6-12 Terminal 53 Low Current

Range:

0.14 mA* [Application dependant]

Function:

Enter the low current value. This reference signal should correspond to the minimum reference value, set in par. 3-02 *Minimum Reference*. The value must be set at >2 mA in order to activate the Live Zero Timeout Function in par. 6-01 *Live Zero Timeout Function*.

6-13 Terminal 53 High Current

Range:

20.00 mA* [Application dependant]

Function:

Enter the high current value corresponding to the high reference/feedback set in par. 6-15 *Terminal 53 High Ref./Feedb. Value*.

6-14 Terminal 53 Low Ref./Feedb. Value

Range:

0.000 N/A* [-999999.999 - 999999.999 N/A]

Function:

Enter the analog input scaling value that corresponds to the low voltage/low current set in par. 6-10 *Terminal 53 Low Voltage* and par. 6-12 *Terminal 53 Low Current*.

6-15 Terminal 53 High Ref./Feedb. Value

Range:

Application [-999999.999 - 999999.999 ReferenceFeedbackUnit]

Function:

Enter the analog input scaling value that corresponds to the maximum reference feedback value set in par. 6-11 *Terminal 53 High Voltage* and par. 6-13 *Terminal 53 High Current*.

6-16 Terminal 53 Filter Time Constant

Range:

0.001 s* [0.001 - 10.000 s]

Function:

Enter the time constant. This is a first-order digital low pass filter time constant for suppressing electrical noise in terminal 53. A high time constant value improves dampening but also increases the time delay through the filter.

This parameter cannot be adjusted while the motor is running.

3.8.4 6-2* Analog Input 2

Parameters for configuring the scaling and limits for analog input 2 (terminal 54).

6-20 Terminal 54 Low Voltage

Range:

0.07 V* [Application dependant]

Function:

Enter the low voltage value. This analog input scaling value should correspond to the minimum reference value, set in par. 3-02 *Minimum Reference*. See also the section *Reference Handling*.

6-21 Terminal 54 High Voltage

Range:

10.00 V* [Application dependant]

Function:

Enter the high voltage value. This analog input scaling value should correspond to the high reference/feedback value set in par. 6-25 *Terminal 54 High Ref./Feedb. Value*.

6-22 Terminal 54 Low Current

Range:

0.14 mA* [Application dependant]

Function:

Enter the low current value. This reference signal should correspond to the minimum reference value, set in par. 3-02 *Minimum Reference*. The value must be set at >2 mA in order to activate the Live Zero Timeout Function in par. 6-01 *Live Zero Timeout Function*.

6-23 Terminal 54 High Current

Range:

20.00 mA* [Application dependant]

Function:

Enter the high current value corresponding to the high reference/feedback value set in par. 6-25 *Terminal 54 High Ref./Feedb. Value*.

6-24 Terminal 54 Low Ref./Feedb. Value

Range:

0 ReferenceFeedbackUnit [-999999.999 - 999999.999 ReferenceFeedbackUnit]

Function:

Enter the analog input scaling value that corresponds to the minimum reference feedback value set in par. 3-02 *Minimum Reference*.

6-25 Terminal 54 High Ref./Feedb. Value

Range:

Application [-999999.999 - 999999.999 ReferenceFeedbackUnit]

Function:

Enter the analog input scaling value that corresponds to the maximum reference feedback value set in par. 3-03 *Maximum Reference*.

6-26 Terminal 54 Filter Time Constant

Range:

0.001 s* [0.001 - 10.000 s]

Function:

Enter the time constant. This is a first-order digital low pass filter time constant for suppressing electrical noise in terminal 54. A high time constant value improves dampening but also increases the time delay through the filter.
This parameter cannot be adjusted while the motor is running.

3.8.5 6-3* Analog Input 3 MCB 101

Parameter group for configuring the scale and limits for analog input 3 (X30/11) placed on option module MCB 101.

6-30 Terminal X30/11 Low Voltage

Range:

0.07 V* [Application dependant]

Function:

Sets the analog input scaling value to correspond to the low reference/feedback value (set in par. 6-34 *Term. X30/11 Low Ref./Feedb. Value*).

6-31 Terminal X30/11 High Voltage

Range:

10.00 V* [Application dependant]

Function:

Sets the analog input scaling value to correspond to the high reference/feedback value (set in par. 6-35 *Term. X30/11 High Ref./Feedb. Value*).

6-34 Term. X30/11 Low Ref./Feedb. Value

Range:

0.000 N/A* [-999999.999 - 999999.999 N/A]

Function:

Sets the analog input scaling value to correspond to the low voltage value (set in par. 6-30 *Terminal X30/11 Low Voltage*).

6-35 Term. X30/11 High Ref./Feedb. Value

Range:

100.000 N/A* [-999999.999 - 999999.999 N/A]

Function:

Sets the analog input scaling value to correspond to the high voltage value (set in par. 6-31 *Terminal X30/11 High Voltage*).

6-36 Term. X30/11 Filter Time Constant

Range:

0.001 s* [0.001 - 10.000 s]

Function:

A 1st order digital low pass filter time constant for suppressing electrical noise on terminal X30/11. Par. 6-36 *Term. X30/11 Filter Time Constant* cannot be changed while the motor is running.

3.8.6 6-4* Analog Input 4 MCB 101

Parameter group for configuring the scale and limits for analog input 4 (X30/12) placed on option module MCB 101.

6-40 Terminal X30/12 Low Voltage

Range:

0.07 V* [Application dependant]

Function:

Sets the analog input scaling value to correspond to the low reference/feedback value set in par. 6-44 *Term. X30/12 Low Ref./Feedb. Value*.

6-41 Terminal X30/12 High Voltage

Range:	Function:
10.00 V* [Application dependant]	Sets the analog input scaling value to correspond to the high reference/feedback value set in par. 6-45 <i>Term. X30/12 High Ref./Feedb. Value</i> .

6-44 Term. X30/12 Low Ref./Feedb. Value

Range:	Function:
0.000 N/A* [-999999.999 - 999999.999 N/A]	Sets the analog output scaling value to correspond to the low voltage value set in par. 6-40 <i>Terminal X30/12 Low Voltage</i> .

6-45 Term. X30/12 High Ref./Feedb. Value

Range:	Function:
100.000 N/ A* [-999999.999 - 999999.999 N/A]	Sets the analog input scaling value to correspond to the high voltage value set in par. 6-41 <i>Terminal X30/12 High Voltage</i> .

6-46 Term. X30/12 Filter Time Constant

Range:	Function:
0.001 s* [0.001 - 10.000 s]	A 1 st order digital low pass filter time constant for suppressing electrical noise on terminal X30/12. Par. 6-46 <i>Term. X30/12 Filter Time Constant</i> cannot be changed while the motor is running.

3.8.7 6-5* Analog Output 1

Parameters for configuring the scaling and limits for analog output 1, i.e., Terminal 42. Analog outputs are current outputs: 0/4–20 mA. Common terminal (terminal 39) is the same terminal and has the same electrical potential for analog common and digital common connection. Resolution on analog output is 12 bit.

6-50 Terminal 42 Output

Option:	Function:
[0] *	No operation When no signal on the analog output.
[52]	MCO 0-20mA
[53]	MCO 4-20mA
[100]	Output frequency 0 Hz = 0 mA; 100 Hz = 20 mA.
[101]	Reference Par. 3-00 <i>Reference Range</i> [Min - Max] 0% = 0 mA; 100% = 20 mA Par. 3-00 <i>Reference Range</i> [-Max - Max] -100% = 0 mA; 0% = 10 mA; +100% = 20 mA
[102]	Feedback
[103]	Motor current Value is taken from par. 16-37 <i>Inv. Max. Current</i> . Inverter max. current (160% current) is equal to 20 mA. Example: Inverter norm current (15 hp [11 kW]) = 24 A. 160% = 38.4 A. Motor norm current = 22 A Readout 11.46 mA. $\frac{20 \text{ mA} \times 22 \text{ A}}{38.4 \text{ A}} = 11.46 \text{ mA}$ If the norm motor current is equal to 20 mA, the output setting of par. 6-52 <i>Terminal 42 Output Max Scale</i> is:

$$\frac{I_{VLT_Max} \times 100}{I_{Motor_Norm}} = \frac{38.4 \times 100}{22} = 175\%$$

[104]	Torque rel to limit	The torque setting is related to setting in par. 4-16 <i>Torque Limit Motor Mode</i>
[105]	Torq relate to rated	The torque is related to the motor torque setting.
[106]	Power	Taken from par. 1-20 <i>Motor Power [kW]</i> .
[107]	Speed	Taken from par. 3-03 <i>Maximum Reference</i> . 20 mA = value in par. 3-03 <i>Maximum Reference</i>
[108]	Torque	Torque reference related to 160% torque.
[109]	Max Out Freq	In relation to par. 4-19 <i>Max Output Frequency</i> .
[113]	PID Clamped Output	
[119]	Torque % lim	
[130]	Output freq. 4-20mA	0 Hz = 4 mA, 100 Hz = 20 mA
[131]	Reference 4-20mA	Par. 3-00 <i>Reference Range</i> [Min-Max] 0% = 4 mA; 100% = 20 mA Par. 3-00 <i>Reference Range</i> [-Max-Max] -100% = 4 mA; 0% = 12 mA; +100% = 20 mA
[132]	Feedback 4-20mA	
[133]	Motor cur. 4-20mA	Value is taken from par. 16-37 <i>Inv. Max. Current</i> . Inverter max. current (160% current) is equal to 20 mA. Example: Inverter norm current (15 hp [11 kW]) = 24 A. 160% = 38.4 A. Motor norm current = 22 A Readout 11.46 mA. $\frac{16 \text{ mA} \times 22 \text{ A}}{38.4 \text{ A}} + 4 \text{ mA} = 13.17 \text{ mA}$ If the norm motor current is equal to 20 mA, the output setting of par. 6-62 <i>Terminal X30/8 Max. Scale</i> is: $\frac{I_{VLT_Max} \times 100}{I_{Motor_Norm}} = \frac{38.4 \times 100}{22} = 175\%$
[134]	Torq.% lim 4-20 mA	The torque setting is related to setting in par. 4-16 <i>Torque Limit Motor Mode</i> .
[135]	Torq.% nom 4-20 mA	The torque setting is related to the motor torque setting.
[136]	Power 4-20mA	Taken from par. 1-20 <i>Motor Power [kW]</i>
[137]	Speed 4-20mA	Taken from par. 3-03 <i>Maximum Reference</i> . 20 mA = Value in par. 3-03 <i>Maximum Reference</i> .
[138]	Torque 4-20mA	Torque reference related to 160% torque.
[139]	Bus ctrl. 0-20 mA	An output value set from serial communication bus process data. The output will work independently of internal functions in the adjustable frequency drive.
[140]	Bus ctrl. 4-20 mA	An output value set from serial communication bus process data. The output will work independently of internal functions in the adjustable frequency drive.
[141]	Bus ctrl 0-20mA t.o.	Par. 4-54 <i>Warning Reference Low</i> defines the behavior of the analog output in the event of bus timeout.
[142]	Bus ctrl 4-20mA t.o.	Par. 4-54 <i>Warning Reference Low</i> defines the behavior of the analog output in the event of bus timeout.
[149]	Torque % lim 4-20mA	Analog output at zero torque = 12 mA. Motoric torque will increase the output current to max torque limit 20 mA (set in par. 4-16). Generative torque will decrease the output to torque limit Generator Mode (set in par. 4-17) Ex: Par. 4-16: 200% and par. 4-17: 200%. 20 mA = 200% Motoric and 4 mA = 200% Generatoric.

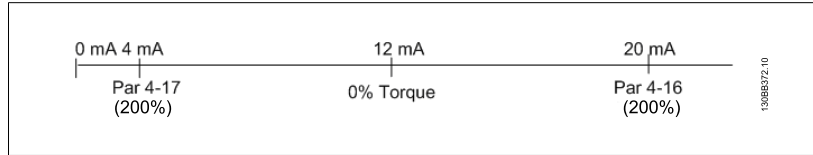

[150] Max Out Fr 4-20mA In relation to par. 4-19 *Max Output Frequency*.

3

6-51 Terminal 42 Output Min Scale

Range: 0.00 %* [0.00 - 200.00 %] **Function:**

6-52 Terminal 42 Output Max Scale

Range: 100.00 %* [0.00 - 200.00 %] **Function:** Scale the maximum output of the selected analog signal at terminal 42. Set the value to the maximum value of the current signal output. Scale the output to give a current lower than 20 mA at full scale; or 20 mA at an output below 100% of the maximum signal value. If 20 mA is the desired output current at a value between 0-100% of the full-scale output, program the percentage value in the parameter, i.e., 50% = 20 mA. If a current between 4 and 20 mA is desired at maximum output (100%), calculate the percentage value as follows:

$20 \text{ mA} / \text{desired maximum current} \times 100 \%$

i.e. $10 \text{ mA} : \frac{20}{10} \times 100 = 200 \%$

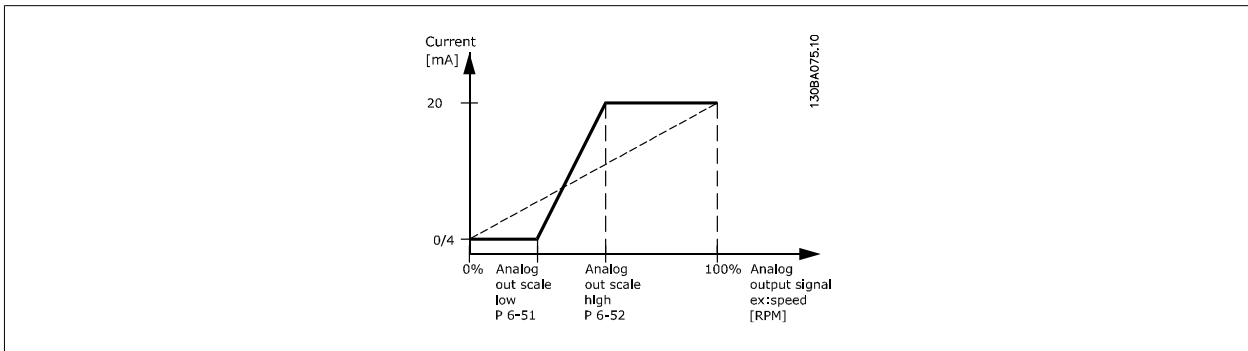

6-53 Terminal 42 Output Bus Control

Range: 0.00 %* [0.00 - 100.00 %] **Function:**

6-54 Terminal 42 Output Timeout Preset

Range: 0.00 %* [0.00 - 100.00 %] **Function:**

6-55 Terminal 42 Output Filter

Option: **Function:** The following readout analogue parameters from selection in par. 6-50 have a filter selected when par. 6-55 is on:

		Selection	0-20 mA	4-20 mA
		Motor current (0 - I _{max})	[103]	[133]
		Torque limit (0 - T _{lim})	[104]	[134]
		Rated torque (0 - T _{nom})	[105]	[135]
		Power (0 - P _{nom})	[106]	[136]
		Speed (0 - Speedmax)	[107]	[137]

[0] *	Off	Filter off
[1]	On	Filter on

3.8.8 6-6* Analog Output 2 MCB 101

Analog outputs are current outputs: 0/4–20 mA. Common terminal (terminal X30/8) is the same terminal and electrical potential for analog common connection. Resolution on analog output is 12 bit.

6-60 Terminal X30/8 Output

Option:

Function:

Select the function of Terminal X30/8 as an analog current output. Depending on the selection the output is either a 0–20 mA or 4–20 mA output. The current value can be read out in LCP in par. 16-65 *Analog Output 42 [mA]*.

[0] *	No operation	When no signal on the analog output.
[52]	MCO 0-20mA	
[100]	Output frequency	0 Hz = 0 mA; 100 Hz = 20 mA.
[101]	Reference	Par. 3-00 <i>Reference Range</i> [Min - Max] 0% = 0 mA; 100% = 20 mA Par. 3-00 <i>Reference Range</i> [-Max - Max] -100% = 0 mA; 0% = 10 mA; +100% = 20 mA
[102]	Feedback	
[103]	Motor current	Value is taken from par. 16-37 <i>Inv. Max. Current</i> . Inverter max. current (160% current) is equal to 20 mA. Example: Inverter norm current (15 hp [11 kW]) = 24 A. 160% = 38.4 A. Motor norm current = 22 A Readout 11.46 mA. $\frac{20 \text{ mA} \times 22 \text{ A}}{38.4 \text{ A}} = 11.46 \text{ mA}$ If the norm motor current is equal to 20 mA, the output setting of par. 6-62 <i>Terminal X30/8 Max. Scale</i> is: $\frac{I_{VLT \text{ Max}} \times 100}{I_{Motor \text{ Norm}}} = \frac{38.4 \times 100}{22} = 175 \%$
[104]	Torque rel to limit	The torque setting is related to setting in par. 4-16 <i>Torque Limit Motor Mode</i> .
[105]	Torq relate to rated	The torque is related to the motor torque setting.
[106]	Power	Taken from par. 1-20 <i>Motor Power [kW]</i> .
[107]	Speed	Taken from par. 3-03 <i>Maximum Reference</i> . 20 mA = value in par. 3-03 <i>Maximum Reference</i>
[108]	Torque	Torque reference related to 160% torque.
[109]	Max Out Freq	In relation to par. 4-19 <i>Max Output Frequency</i> .
[113]	PID Clamped Output	

[119]	Torque % lim	
[130]	Output freq. 4-20mA	0 Hz = 4 mA, 100 Hz = 20 mA
[131]	Reference 4-20mA	Par. 3-00 <i>Reference Range</i> [Min-Max] 0% = 4 mA; 100% = 20 mA Par. 3-00 <i>Reference Range</i> [-Max-Max] -100% = 4 mA; 0% = 12 mA; +100% = 20 mA
[132]	Feedback 4-20mA	
[133]	Motor cur. 4-20mA	Value is taken from par. 16-37 <i>Inv. Max. Current</i> . Inverter max. current (160% current) is equal to 20 mA. Example: Inverter norm current (15 hp [11 kW]) = 24 A. 160% = 38.4 A. Motor norm current = 22 A Readout 11.46 mA. $\frac{16 \text{ mA} \times 22 \text{ A}}{38.4 \text{ A}} = 9.17 \text{ mA}$ If the norm motor current is equal to 20 mA, the output setting of par. 6-62 <i>Terminal X30/8 Max. Scale</i> is: $\frac{I_{VLT \text{ Max}} \times 100}{I_{\text{Motor Norm}}} = \frac{38.4 \times 100}{22} = 175 \%$
[134]	Torq.% lim 4-20 mA	The torque setting is related to setting in par. 4-16 <i>Torque Limit Motor Mode</i> .
[135]	Torq.% nom 4-20 mA	The torque setting is related to the motor torque setting.
[136]	Power 4-20mA	Taken from par. 1-20 <i>Motor Power [kW]</i>
[137]	Speed 4-20mA	Taken from par. 3-03 <i>Maximum Reference</i> . 20 mA = Value in par. 3-03 <i>Maximum Reference</i> .
[138]	Torque 4-20mA	Torque reference related to 160% torque.
[139]	Bus ctrl. 0-20 mA	An output value set from serial communication bus process data. The output will work independently of internal functions in the adjustable frequency drive.
[140]	Bus ctrl. 4-20 mA	An output value set from serial communication bus process data. The output will work independently of internal functions in the adjustable frequency drive.
[141]	Bus ctrl 0-20mA t.o.	Par. 4-54 <i>Warning Reference Low</i> defines the behavior of the analog output in the event of bus timeout.
[142]	Bus ctrl 4-20mA t.o.	Par. 4-54 <i>Warning Reference Low</i> defines the behavior of the analog output in the event of bus timeout.
[149]	Torque % lim 4-20mA	Torque % Lim 4–20 mA: Torque reference. par. 3-00 <i>Reference Range</i> [Min-Max] 0% = 4 mA; 100% = 20 mA Par. 3-00 <i>Reference Range</i> [-Max-Max] -100% = 4 mA; 0% = 12mA; +100% = 20 mA
[150]	Max Out Fr 4-20mA	In relation to par. 4-19 <i>Max Output Frequency</i> .

6-61 Terminal X30/8 Min. Scale**Range:**

0.00 %* [0.00 - 200.00 %]

Function:**6-62 Terminal X30/8 Max. Scale****Range:**

100.00 %* [0.00 - 200.00 %]

Function:20 mA / *desired maximum current* x 100 %

$$i.e. 10 \text{ mA} : \frac{20 - 4}{10} \times 100 = 160 \%$$

6-63 Terminal X30/8 Bus Control

Range:	Function:
0.00 %* [0.00 - 100.00 %]	

6-64 Terminal X30/8 Output Timeout Preset

Range:	Function:
0.00 %* [0.00 - 100.00 %]	

3.8.9 6-7* Analog Output 3 MCB113

Parameters for configuring the scaling and limits for analog output 3, Terminal X45/1 and X45/2. Analog outputs are current outputs: 0/4–20 mA. Resolution on analog output is 11 bit.

6-70 Terminal X45/1 Output

Option:	Function:
	Select the function of Terminal X45/1 as an analog current output.
[0] No operation	When no signal on the analog output.
[52] MCO 305 0–20 mA	
[53] MCO 305 4–20 mA	
[100] Output frequency 0–20 mA	0 Hz = 0 mA; 100 Hz = 20 mA.
[101] Reference 0–20 mA	Par. 3-00 [Min - Max] 0% = 0 mA; 100% = 20 mA Par. 3-00 [-Max - Max] -100% = 0 mA; 0% = 10 mA; +100% = 20 mA
[102] Feedback	
[103] Motor current 0–20 mA	Value is taken from par. 16-37. Inverter max. current (160% current) is equal to 20 mA. Example: Inverter norm current (15 hp [11 kW]) = 24 A. 160% = 38.4 A. Motor norm current = 22 A Readout 11.46 mA. $\frac{20 \text{ mA} \times 22 \text{ A}}{38.4 \text{ A}} = 11.46 \text{ mA}$ If the norm motor current is equal to 20 mA, the output setting of par. 6-52 is: $\frac{I_{VLT_Max} \times 100}{I_{Motor_Norm}} = \frac{38.4 \times 100}{22} = 175 \%$
[104] Torque rel to lim 0–20 mA	The torque setting is related to setting in par. 4-16
[105] Torque rel to rated motor torque 0–20 mA	The torque is related to the motor torque setting.
[106] Power 0–20 mA	Taken from par. 1-20.
[107] Speed 0–20 mA	Taken from par. 3-03. 20 mA = value in par. 3-03
[108] Torque ref. 0–20 mA	Torque reference related to 160% torque.
[109] Max Out Freq 0–20 mA	In relation to par. 4-19.
[130] Output freq. 4-20 mA	0 Hz = 4 mA, 100 Hz = 20 mA
[131] Reference 4–20 mA	Par. 3-00 [Min–Max] 0% = 4 mA; 100% = 20 mA Par. 3-00 [-Max–Max] -100% = 4 mA; 0% = 12 mA; +100% = 20 mA
[132] Feedback 4–20 mA	
[133] Motor cur. 4–20 mA	Value is taken from par. 16-37. Inverter max. current (160% current) is equal to 20 mA. Example: Inverter norm current (15 hp [11 kW]) = 24 A. 160% = 38.4 A. Motor norm current = 22 A Readout 11.46 mA. $\frac{16 \text{ mA} \times 22 \text{ A}}{38.4 \text{ A}} = 9.17 \text{ mA}$ If the norm motor current is equal to 20 mA, the output setting of par. 6-52 is:

$$\frac{I_{VLT_{Max}} \times 100}{I_{Motor_{Norm}}} = \frac{38.4 \times 100}{22} = 175 \%$$

[134]	Torque % lim. 4–20 mA	The torque setting is related to setting in par. 4-16.
[135]	Torque % nom 4–20 mA	The torque setting is related to the motor torque setting.
[136]	Power 4–20 mA	Taken from par. 1-20
[137]	Speed 4–20 mA	Taken from par. 3-03. 20 mA = Value in par. 3-03.
[138]	Torque 4–20 mA	Torque reference related to 160% torque.
[139]	Bus ctrl. 0–20 mA	An output value set from the serial communication bus process data. The output will work independently of internal functions in the adjustable frequency drive.
[140]	Bus ctrl. 4–20 mA	An output value set from the serial communication bus process data. The output will work independently of internal functions in the adjustable frequency drive.
[141]	Bus ctrl. 0–20 mA, timeout	Par. 4-54 defines the behavior of the analog output in the event of a bus timeout.
[142]	Bus ctrl. 4–20 mA, timeout	Par. 4-54 defines the behavior of the analog output in the event of a bus timeout.
[150]	Max Out Freq 4–20 mA	In relation to par. 4-19.

6-71 Terminal X45/1 Output Min Scale

Range:

0.00%* [0.00–200.00%]

Function:

Scale the minimum output of the selected analog signal at terminal X45/1, as a percentage of the maximum signal value, e.g., if 0 mA (or 0 Hz) is desired at 25% of the maximum output value, program 25%. Scaling values up to 100% can never be higher than the corresponding setting in par. 6-72.

6-72 Terminal X45/1 Output Max Scale

Range:

100%* [0.00–200.00%]

Function:

Scale the maximum output of the selected analog signal at terminal X45/1. Set the value to the maximum value of the current signal output. Scale the output to give a current lower than 20 mA at full scale; or 20 mA at an output below 100% of the maximum signal value. If 20 mA is the desired output current at a value between 0-100% of the full-scale output, program the percentage value in the parameter, i.e., 50% = 20 mA. If a current between 4 and 20 mA is desired at maximum output (100%), calculate the percentage value as follows (example where desired max. output is 10 mA):

$$\frac{I_{RANGE} [mA]}{I_{DESIRED MAX} [mA]} \times 100 \% = \frac{20 - 4 mA}{10 mA} \times 100 \% = 160 \%$$

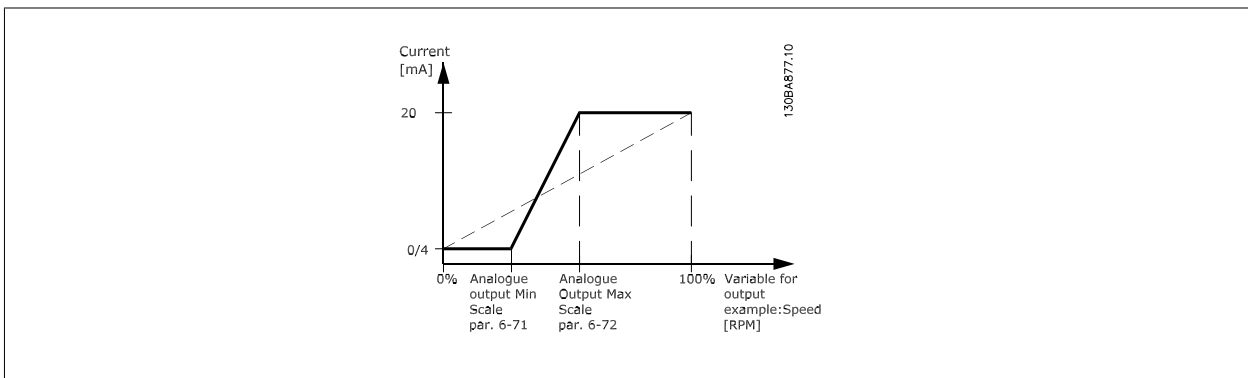

6-73 Terminal X45/1 Output Bus Control

Range:

0.00%* [0.00–100.00%]

Function:

Holds the level of Analog Output 3 (terminal X45/1) if controlled by bus.

6-74 Terminal X45/1 Output Timeout Preset

Range: 0.00%* [0.00–100.00%]	Function: Holds the preset level of Analog Output 3 (terminal X45/1). In a bus timeout occurs and a timeout function selected in par. 6-70, the output will preset to this level.
--	--

3.8.10 6-8* Analog Output 4 MCB113

Parameters for configuring the scaling and limits for analog output 4. Terminal X45/3 and X45/4. Analog outputs are current outputs: 0/4–20 mA. Resolution on analog output is 11 bit.

6-80 Terminal X45/3 Output

Option: [0] * No operation	Function: Select the function of Terminal X45/3 as an analog current output. Same selections available as for par. 6-70
--------------------------------------	--

6-81 Terminal X45/3 Output Min Scale

Option: [0.00%] * 0.00–200.00%	Function: Scales the minimum output of the selected analog signal on terminal X45/3. Scale the minimum value as a percentage of the maximum signal value, i.e., 0 mA (or 0 Hz) is desired at 25% of the maximum output value and 25% is programmed. The value can never be higher than the corresponding setting in par. 6-82 if the value is below 100%. This parameter is active when option module MCB 113 is mounted in the adjustable frequency drive.
--	--

6-82 Terminal X45/3 Output Max Scale

Option: [0.00%] * 0.00–200.00%	Function: Scales the maximum output of the selected analog signal on terminal X45/3. Scale the value to the desired maximum value of the current signal output. Scale the output to give a lower current than 20 mA at full scale or 20 mA at an output below 100% of the maximum signal value. If 20 mA is the desired output current at a value between 0%–100% of the full-scale output, program the percentage value in the parameter, i.e., 50% = 20 mA. If a current between 4 and 20 mA is desired at maximum output (100%), calculate the percentage value as follows (example where desired max. output is 10 mA):
--	---

$$\frac{I_{RANGE} [mA]}{I_{DESIRED MAX} [mA]} \times 100\% = \frac{20 - 4 mA}{10 mA} \times 100\% = 160\%$$

6-83 Terminal X45/3 Output Bus Control

Option: [0.00%] * 0.00–100.00%	Function: Holds the level of output 4 (X45/3) if controlled by bus.
--	---

6-84 Terminal X45/3 Output Timeout Preset

Option: [0.00%] * 0.00–100.00%	Function: Holds the present level of output 4 (X45/3). If a bus timeout occurs and a timeout function is selected in par. 6-80, the output will preset to this level.
--	---

3.9 Parameters: Controllers

3.9.1 7-** Controllers

Parameter group for configuring application controls.

3.9.2 7-0* Speed PID Ctrl.

Parameters for configuring the speed PID control.

7-00 Speed PID Feedback Source

Option:

Function:

Select the encoder for closed-loop feedback.
The feedback may come from a different encoder (typically mounted on the application itself) than the motor mounted encoder feedback selected in par. 1-02 *Flux Motor Feedback Source*.
This parameter cannot be adjusted while the motor is running.

[0] * Motor feedb. P1-02

[1] 24V encoder

[2] MCB 102

[3] MCB 103

[5] MCO Encoder 2

[6] Analog input 53

[7] Analog input 54

[8] Frequency input 29

[9] Frequency input 33



NOTE!

If separate encoders are used (FC 302 only), the ramp settings parameters in the following groups: 3-4*, 3-5*, 3-6*, 3-7* and 3-8* must be adjusted according to the gear ratio between the two encoders.

7-02 Speed PID Proportional Gain

Range:

Function:

Application [0.000 - 1.000]
dependent*

Enter the speed controller proportional gain. The proportional gain amplifies the error (i.e., the deviation between the feedback signal and the setpoint). This parameter is used with par. 1-00 *Configuration Mode Speed open-loop* [0] and *Speed closed-loop* [1] control. Quick control is obtained at high amplification. However, if the amplification is too great, the process may become unstable.

Use this parameter for values with three decimals. For a selection with four decimals, use par. 3-83.

7-03 Speed PID Integral Time

Range:

Function:

Application [2.0 - 20000.0 ms]
dependent*

Enter the speed controller integral time, which determines the time the internal PID control takes to correct errors. The greater the error, the more quickly the gain increases. The integral time causes a delay of the signal and therefore a damping effect, and can be used to eliminate steady state speed error. Obtain quick control through a short integral time, though if the integral time is too short, the process becomes unstable. An excessively long integral time disables the integral action, leading to major deviations from the required reference, since the process regulator takes too long

to regulate errors. This parameter is used with *Speed open-loop* [0] and *Speed closed-loop* [1] control, set in par. 1-00 *Configuration Mode*.

7-04 Speed PID Differentiation Time

Range:

Application [0.0 - 200.0 ms]
dependent*

Function:

Enter the speed controller differentiation time. The differentiator does not react to constant error. It provides gain proportional to the rate of change of the speed feedback. The quicker the error changes, the stronger the gain from the differentiator. The gain is proportional with the speed at which errors change. Setting this parameter to zero disables the differentiator. This parameter is used with par. 1-00 *Configuration Mode Speed closed-loop* [1] control.

7-05 Speed PID Diff. Gain Limit

Range:

5.0* [1.0 - 20.0]

Function:

Set a limit for the gain provided by the differentiator. Since the differential gain increases at higher frequencies, limiting the gain may be useful. For example, set up a pure D-link at low frequencies and a constant D-link at higher frequencies. This parameter is used with par. 1-00 *Configuration Mode Speed closed-loop* [1] control.

7-06 Speed PID Lowpass Filter Time

Range:

10.0 ms* [1.0 - 100.0 ms]

Function:

Set a time constant for the speed control low-pass filter. The low-pass filter improves steady-state performance and dampens oscillations on the feedback signal. This is an advantage if there is a great amount on noise in the system; see figure below. For example, if a time constant (τ) of 100 ms is programmed, the cut-off frequency for the low-pass filter will be $1/0.1 = 10$ RAD/sec., corresponding to $(10/2 \times \pi) = 1.6$ Hz. The PID regulator only regulates a feedback signal that varies by a frequency of less than 1.6 Hz. If the feedback signal varies by a frequency higher than 1.6 Hz, the PID regulator does not react.

Practical settings of par. 7-06 *Speed PID Lowpass Filter Time* taken from the number of pulses per revolutions from encoder:

Encoder PPR	Par. 7-06 <i>Speed PID Lowpass Filter Time</i>
512	10 ms
1024	5 ms
2048	2 ms
4096	1 ms

Note that severe filtering can be detrimental to dynamic performance.

This parameter is used with par. 1-00 *Configuration Mode Speed closed-loop* [1] and *Torque* [2] control.

The filter time in flux sensorless must be adjusted to 3–5 ms.

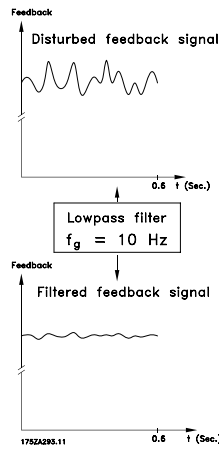

7-07 Speed PID Feedback Gear Ratio

Range: 1.0000* [Application dependant] **Function:**

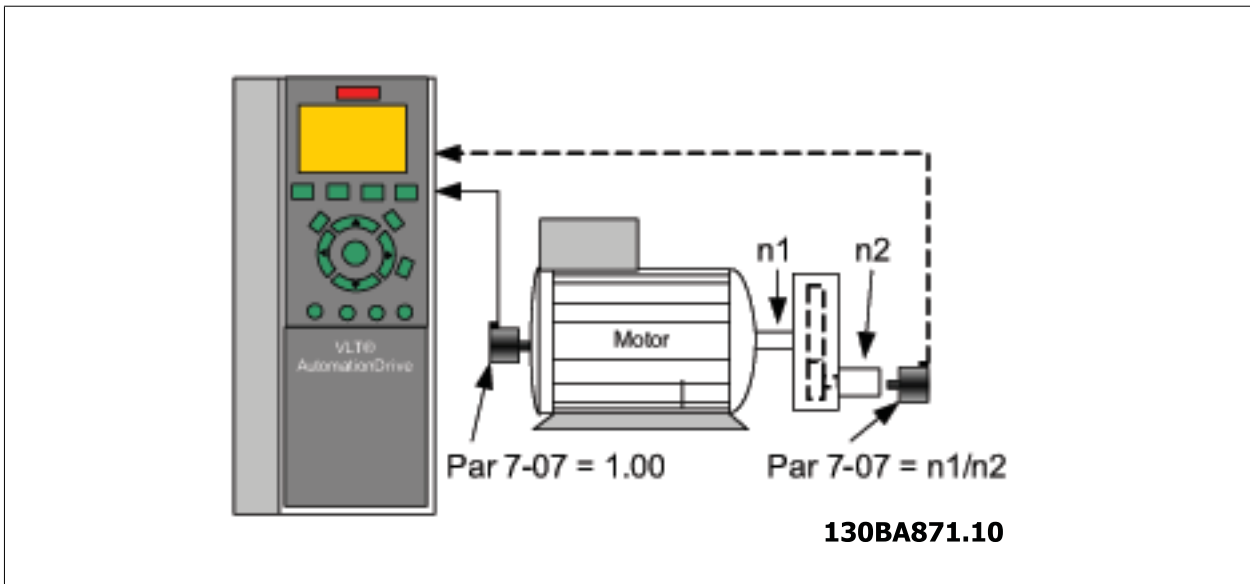

7-08 Speed PID Feed Forward Factor

Range: 0 %* [0 - 500 %] **Function:** The reference signal bypasses the speed controller by the amount specified. This feature increases the dynamic performance of the speed control loop.

3.9.3 7-1* Torque PI Control

Parameters for configuring the torque PI control in torque open-loop (par. 1-00 *Configuration Mode*).

7-12 Torque PI Proportional Gain

Range:	Function:
100 %* [0 - 500 %]	Enter the proportional gain value for the torque controller. Selection of a high value makes the controller react faster. Too high a setting leads to controller instability.

7-13 Torque PI Integration Time

Range:	Function:
0.020 s* [0.002 - 2.000 s]	Enter the integration time for the torque controller. Selecting a low value causes the controller to react faster. Too low a setting leads to control instability.

3.9.4 7-2* Process Ctrl. Feedb.

Select the feedback sources for the process PID control, and the way in which this feedback should be handled.

7-20 Process CL Feedback 1 Resource

Option:	Function:
	The effective feedback signal is made up of the sum of up to two different input signals. Select which adjustable frequency drive input should be treated as the source of the first of these signals. The second input signal is defined in par. 7-22 <i>Process CL Feedback 2 Resource</i> .
[0] *	No function
[1]	Analog input 53
[2]	Analog input 54
[3]	Frequency input 29
[4]	Frequency input 33
[7]	Analog input X30/11 (OPCGPIO)
[8]	Analog input X30/12 (OPCGPIO)

7-22 Process CL Feedback 2 Resource

Option:	Function:
	The effective feedback signal is made up of the sum of up to two different input signals. Select which adjustable frequency drive input should be treated as the source of the second of these signals. The first input signal is defined in par. 7-21.
[0] *	No function
[1]	Analog input 53
[2]	Analog input 54
[3]	Frequency input 29
[4]	Frequency input 33
[7]	Analog input X30/11 (OPCGPIO)
[8]	Analog input X30/12 (OPCGPIO)

3.9.5 7-3* Process PID Ctrl.

Parameters for configuring the Process PID control.

7-30 Process PID Normal/Inverse Control

Option:	Function:
[0] * Normal	Normal and inverse control are implemented by introducing a difference between the reference signal and the feedback signal. Sets process control in order to increase the output frequency.
[1] Inverse	Sets process control in order to reduce the output frequency.

7-31 Process PID Anti Wind-up

Option:	Function:
[0] * Off	Ceases regulation of an error when the output frequency can no longer be adjusted.
[1] On	Continues regulation of an error even when the output frequency cannot be increased or decreased.

7-32 Process PID Controller Start Value

Range:	Function:
0 rpm* [0 - 6,000 rpm]	Enter the motor speed to be attained as a start signal for commencement of PID control. When the power is switched on, the adjustable frequency drive will commence ramping and then operate under speed open-loop control. Afterwards, when the process PID start speed is reached, the adjustable frequency drive will change over to process PID control.

7-33 Process PID Proportional Gain

Range:	Function:
0.01* [0.00 - 10.00]	Enter the PID proportional gain. The proportional gain multiplies the error between the setpoint and the feedback signal.

7-34 Process PID Integral Time

Range:	Function:
10000.00 s* [0.01 - 10000.00 s]	Enter the PID integral time. The integrator provides an increasing gain at a constant error between the setpoint and the feedback signal. The integral time is the time needed by the integrator to reach the same gain as the proportional gain.

7-35 Process PID Differentiation Time

Range:	Function:
0.00 s* [0.00 - 10.00 s]	Enter the PID differentiation time. The differentiator does not react to a constant error, but provides a gain only when the error changes. The shorter the PID differentiation time, the stronger the gain from the differentiator.

7-36 Process PID Differentiation Gain Limit

Range:	Function:
5.0* [1.0 - 50.0]	Enter a limit for the differentiator gain (DG). If there is no limit, the DG will increase when there are fast changes. Limit the DG to obtain a pure differentiator gain at slow changes, and a constant differentiator gain where fast changes occur.

7-38 Process PID Feed Forward Factor

Range:	Function:
0 %* [0 - 500 %]	Enter the PID feed forward (FF) factor. The FF factor sends a constant fraction of the reference signal to bypass PID control, which means that PID control only affects the remaining fraction of the control signal. Any change to this parameter will thus affect the motor speed. When the FF factor

is activated it provides less overshoot, and high dynamics when changing the setpoint. par. 7-38 *Process PID Feed Forward Factor* is active when par. 1-00 *Configuration Mode* is set to [3] Process.

7-39 On Reference Bandwidth

Range:	Function:
5 %* [0 - 200 %]	Enter the On Reference bandwidth. When the PID control error (the difference between the reference and the feedback) is less than the set value of this parameter, the On Reference status bit is high, i.e., it equals 1.

3.9.6 7-4* Advanced Process PID Ctrl.

7-40 Process PID I-part Reset

Option:	Function:
[0] * No	Select Yes [1] to reset the I-part of the process PID controller. The selection will automatically revert to No [0].
[1] Yes	

7-41 Process PID Output Neg. Clamp

Range:	Function:
-100 %* [Application dependant]	Enter a negative limit for the process PID controller output.

7-42 Process PID Output Pos. Clamp

Range:	Function:
100 %* [Application dependant]	Enter a positive limit for the process PID controller output.

7-43 Process PID Gain Scale at Min. Ref.

Range:	Function:
100 %* [0 - 100 %]	Enter a scaling percentage to apply to the process PID output when operating at the minimum reference. The scaling percentage will be adjusted linearly between the scale at min. ref. (par. 7-43) and the scale at max. ref. (par. 7-44).

7-44 Process PID Gain Scale at Max. Ref.

Range:	Function:
100 %* [0 - 100 %]	Enter a scaling percentage to apply to the process PID output when operating at the maximum reference. The scaling percentage will be adjusted linearly between the scale at min. ref. (par. 7-43) and the scale at max. ref. (par. 7-44).

7-45 Process PID Feed Fwd Resource

Option:	Function:
[0] * No function	Select which drive input should be used as the feed forward factor. The FF factor is added directly to the output of the PID controller. This increases dynamic performance.
[1] Analog input 53	
[2] Analog input 54	
[7] Frequency input 29	
[8] Frequency input 33	
[11] Local bus reference	

[20]	Digital pot.meter
------	-------------------

[21]	Analog input X30-11
------	---------------------

[22]	Analog input X30-12
------	---------------------

7-46 Process PID Feed Fwd Normal/ Inv. Ctrl.

Option:
Function:

[0] *	Normal
-------	--------

Select Normal [0] to set the feed forward factor to treat the FF resource as a positive value.
--

[1]	Inverse
-----	---------

Select Inverse [1] to treat the FF resource as a negative value.
--

7-49 Process PID Output Normal/ Inv. Ctrl.

Option:
Function:

[0] *	Normal
-------	--------

Select Normal [0] to use the resulting output from the process PID controller as is.
--

[1]	Inverse
-----	---------

Select Inverse [1] to invert the resulting output from the process PID controller. This operation is performed after the feed forward factor is applied.
--

3.9.7 7-5* Process PID Ctrl.

7-50 Process PID Extended PID

Option:
Function:

[0]	Disabled
-----	----------

Disables the process PID controller.

[1] *	Enabled
-------	---------

Enables the process PID controller.

7-51 Process PID Feed Fwd Gain

Range:
Function:

1.00*	[0.00 - 100.00]
-------	------------------

7-52 Process PID Feed Fwd Ramp up

Range:
Function:

0.01 s*	[0.01 - 10.00 s]
---------	------------------

7-53 Process PID Feed Fwd Ramp down

Range:
Function:

0.01 s*	[0.01 - 10.00 s]
---------	------------------

7-56 Process PID Ref. Filter Time

Range:
Function:

0.001 s*	[0.001 - 1.000 s]
----------	-------------------

Set a time constant for the reference first order low-pass filter. The low-pass filter improves steady-state performance and dampens oscillations on the reference/feedback signals. However, severe filtering can be detrimental to dynamic performance.

7-57 Process PID Fb. Filter Time

Range:
Function:

0.001 s*	[0.001 - 1.000 s]
----------	-------------------

Set a time constant for the feedback first order low-pass filter. The low-pass filter improves steady-state performance and dampens oscillations on the reference/feedback signals. However, severe filtering can be detrimental to dynamic performance.
--

3.10 Parameters: Communications and Options

3.10.1 8-*** Comm. and Options

Parameter group for configuring communications and options.

3.10.2 8-0* General Settings

General settings for communications and options.

8-01 Control Site

Option:	Function:
	The setting in this parameter overrides the settings in par. 8-50 <i>Coasting Select</i> to par. 8-56 <i>Preset Reference Select</i> .
[0] * Digital and ctrl. word	Control by using both digital input and control word.
[1] Digital only	Control by using digital inputs only.
[2] Control word only	Control by using control word only.

8-02 Control Word Source

Select the source of the control word: one of two serial interfaces or four installed options. During initial power-up, the adjustable frequency drive automatically sets this parameter to *Option A* [3] if it detects a valid serial communication option installed in slot A. If the option is removed, the adjustable frequency drive detects a change in the configuration, sets par. 8-02 *Control Word Source* back to default setting *Adjustable Frequency Drive RS485*, and the adjustable frequency drive then trips. If an option is installed after initial power-up, the setting of par. 8-02 *Control Word Source* will not change but the adjustable frequency drive will trip and display: Alarm 67 *Option Changed*. This parameter cannot be adjusted while the motor is running.

Option:	Function:
[0] None	
[1] FC RS-485	
[2] FC USB	
[3] * Option A	
[4] Option B	
[5] Option C0	
[6] Option C1	
[30] External Can	

8-03 Control Word Timeout Time

Range:	Function:
1.0 s* [0.1 - 18000.0 s]	Enter the maximum time expected to pass between the reception of two consecutive messages. If this time is exceeded, it indicates that the serial communication has stopped. The function selected in par. 8-04 <i>Control Word Timeout Function</i> will then be carried out. The timeout counter is triggered by a valid control word.

8-04 Control Word Timeout Function

Select the timeout function. The timeout function activates when the control word fails to be updated within the time period specified in par. 8-03 *Control Word Timeout Time*.

Option:	Function:
[0] * Off	Resumes control via serial bus (serial communication bus or standard) using the most recent control word.
[1] Freeze output	Freezes output frequency until communication resumes.
[2] Stop	Stops with auto-restart when communication resumes.
[3] Jogging	Runs the motor at JOG frequency until communication resumes.
[4] Max. speed	Runs the motor at maximum frequency until communication resumes.
[5] Stop and trip	Stops the motor, then resets the adjustable frequency drive in order to restart: via the serial communication bus, via the reset button on the LCP or via a digital input.
[7] Select setup 1	Changes the set-up upon reestablishment of communication following a control word timeout. If communication resumes causing the timeout situation to disappear, par. 8-05 <i>End-of-Timeout Function</i> defines whether to resume the set-up used before the timeout or to retain the set-up endorsed by the timeout function.
[8] Select setup 2	See [7] <i>Select set-up 1</i>
[9] Select setup 3	See [7] <i>Select set-up 1</i>
[10] Select setup 4	See [7] <i>Select set-up 1</i>

**NOTE!**

The following configuration is required in order to change the set-up after a timeout:

Set par. 0-10 *Active Set-up* to [9] *Multi set-up* and select the relevant link in par. 0-12 *This Set-up Linked to*.

8-05 End-of-Timeout Function

Option:	Function:
	Select the action after receiving a valid control word following a timeout. This parameter is active only when par. 8-04 <i>Control Timeout Function</i> is set to [Set-up 1-4].
[0] Hold set-up	Retains the set-up selected in par. 8-04 <i>Control Timeout Function</i> and displays a warning, until par. 8-06 <i>Reset Control Timeout</i> toggles. Then the adjustable frequency drive resumes its original set-up.
[1] * Resume set-up	Resumes the set-up active prior to the timeout.

8-06 Reset Control Word Timeout

This parameter is active only when *Hold set-up* [0] has been selected in par. 8-05 *End-of-Timeout Function*.

Option:	Function:
[0] * Do not reset	Retains the set-up specified in par. 8-04 <i>Control Word Timeout Function</i> , following a control word timeout.
[1] Do reset	Returns the adjustable frequency drive to the original set-up following a control word timeout. The adjustable frequency drive performs the reset and then immediately reverts to the <i>Do not reset</i> [0] setting

8-07 Diagnosis Trigger

Option:	Function:
	This parameter enables and controls the adjustable frequency drive diagnosis function and permits expansion of the diagnosis data to 24 bytes.



NOTE!

This is only valid for Profibus.

- *Disable* [0]: Do not send extended diagnosis data even if they appear in the adjustable frequency drive.
- *Trigger on alarms* [1]: Send extended diagnosis data when one or more alarms appear in alarm par. 16-90 *Alarm Word* or par. 9-53 *Profibus Warning Word*.
- *Trigger alarms/warn.* [2]: Send extended diagnosis data if one or more alarms or warnings appear in alarm par. 16-90 *Alarm Word*, par. 9-53 *Profibus Warning Word*, or warning par. 16-92 *Warning Word*.

The content of the extended diagnosis frame is as follows:

Byte	Content	Description
0 - 5	Standard DP Diagnose Data	Standard DP Diagnose Data
6	PDU length xx	Header of extended diagnostic data
7	Status type = 0x81	Header of extended diagnostic data
8	Slot = 0	Header of extended diagnostic data
9	Status info = 0	Header of extended diagnostic data
10 - 13	VLT par. 16-92 <i>Warning Word</i>	VLT warning word
14 - 17	VLT par. 16-03 <i>Status Word</i>	VLT status word
18 - 21	VLT par. 16-90 <i>Alarm Word</i>	VLT alarm word
22 - 23	VLT par. 9-53 <i>Profibus Warning Word</i>	Communication warning word (Profibus)

Enabling diagnosis may cause increased bus traffic. Diagnosis functions are not supported by all serial communication bus types.

- [0] * Disable
- [1] Trigger on alarms
- [2] Trigger alarm/warn.

3.10.3 8-1* Ctrl. Word Settings

Parameters for configuring the option control word profile.

8-10 Control Word Profile

Select the interpretation of the control and status words corresponding to the installed serial communication bus. Only the selections valid for the serial communication bus installed in slot A will be visible in the LCP display.

For guidelines in selection of *FC profile* [0] and *PROFIdrive profile* [1] please refer to the *Serial communication via RS 485 Interface* section.

For additional guidelines in the selection of *PROFIdrive profile* [1], *ODVA* [5] and *CANopen DSP 402* [7], please refer to the Instruction Manual for the installed serial communication bus.

Option:

Function:

- [0] * FC profile
- [1] PROFIdrive profile
- [5] ODVA
- [7] CANopen DSP 402
- [8] MCO

8-13 Configurable Status Word STW

Option:
Function:

This parameter enables configuration of bits 12 – 15 in the status word.

[0]	No function	The input is always low.
[1] *	Profile Default	Depended on the profile set in Parameter 8-10.
[2]	Alarm 68 Only	The input will go high whenever Alarm 68 is active and will go low whenever no alarm 68 is active
[3]	Trip excl Alarm 68	The input will go high whenever Trip on other alarms is active, and then Alarm 68 is active.
[10]	T18 DI status.	The input will go high whenever T18 has 24 V and will go low whenever T18 has 0 V.
[11]	T19 DI status.	The input will go high whenever T19 has 24 V and will go low whenever T19 has 0 V.
[12]	T27 DI status.	The input will go high whenever T27 has 24 V and will go low whenever T27 has 0 V.
[13]	T29 DI status.	The input will go high whenever T29 has 24 V and will go low whenever T29 has 0 V.
[14]	T32 DI status.	The input will go high whenever T32 has 24 V and will go low whenever T32 has 0 V.
[15]	T33 DI status.	The input will go high whenever T33 has 24 V and will go low whenever T33 has 0 V.
[16]	T37 DI status	The input will go high whenever T37 has 0 V and will go low whenever T37 has 24 V
[21]	Thermal warning	The thermal warning turns on when the temperature exceeds the limit in the motor, the adjustable frequency drive, the brake resistor, or the thermistor.
[30]	Brake fault (IGBT)	Will go high when the brake IGBT is short-circuited.
[40]	Out of ref range	If Comparator 0 is evaluated as TRUE, the input will go high. Otherwise, it will be low.
[60]	Comparator 0	If Comparator 0 is evaluated as TRUE, the input will go high. Otherwise, it will be low.
[61]	Comparator 1	If Comparator 1 is evaluated as TRUE, the input will go high. Otherwise, it will be low.
[62]	Comparator 2	If Comparator 2 is evaluated as TRUE, the input will go high. Otherwise, it will be low.
[63]	Comparator 3	If Comparator 3 is evaluated as TRUE, the input will go high. Otherwise, it will be low.
[64]	Comparator 4	If Comparator 4 is evaluated as TRUE, the input will go high. Otherwise, it will be low.
[65]	Comparator 5	If Comparator 5 is evaluated as TRUE, the input will go high. Otherwise, it will be low.
[70]	Logic Rule 0	If Logic Rule 0 is evaluated as TRUE, the input will go high. Otherwise, it will be low.
[71]	Logic Rule 1	If Logic Rule 1 is evaluated as TRUE, the input will go high. Otherwise, it will be low.
[72]	Logic Rule 2	If Logic Rule 2 is evaluated as TRUE, the input will go high. Otherwise, it will be low.
[73]	Logic Rule 3	If Logic Rule 3 is evaluated as TRUE, the input will go high. Otherwise, it will be low.
[74]	Logic Rule 4	If Logic Rule 4 is evaluated as TRUE, the input will go high. Otherwise, it will be low.
[75]	Logic Rule 5	If Logic Rule 5 is evaluated as TRUE, the input will go high. Otherwise, it will be low.
[80]	SL Digital Output A	SL Controller Action. The input will go high whenever the Smart Logic Action [38] Set dig. out. A high is executed. The input will go low whenever the Smart Logic Action [32] Set dig. out. A low is executed.
[81]	SL Digital Output B	SL Controller Action. The input will go high whenever the Smart Logic Action [39] Set dig. out. A high is executed. The input will go low whenever the Smart Logic Action [33] Set dig. out. A low is executed.
[82]	SL Digital Output C	SL Controller Action. The input will go high whenever the Smart Logic Action [40] Set dig. out. A high is executed. The input will go low whenever the Smart Logic Action [34] Set dig. out. A low is executed.
[83]	SL Digital Output D	SL Controller Action. The input will go high whenever the Smart Logic Action [41] Set dig. out. A high is executed. The input will go low whenever the Smart Logic Action [35] Set dig. out. A low is executed.
[84]	SL Digital Output E	SL Controller Action. The input will go high whenever the Smart Logic Action [42] Set dig. out. A high is executed. The input will go low whenever the Smart Logic Action [36] Set dig. out. A low is executed.

[85] SL Digital Output F SL Controller Action. The input will go high whenever the Smart Logic Action [43] Set dig. out. A high is executed. The input will go low whenever the Smart Logic Action [37] Set dig. out. A low is executed

8-14 Configurable Control Word CTW

Option:	Function:
	Selection of control word bit 10 if it is active low or active high
[0]	None
[1] *	Profile default
[2]	CTW Valid, active low

3

3.10.4 8-3* FC Port Settings

Parameters for configuring the FC Port.

8-30 Protocol

Option:	Function:
[0] *	FC
[1]	FC MC Select the protocol for the FC (standard) port.
[2]	Modbus RTU

8-31 Address

Range:	Function:
Application [Application dependant] dependent*	

8-32 FC Port Baud Rate

Option:	Function:
[0]	2400 Baud Baud rate selection for the FC (standard) port.
[1]	4800 Baud
[2] *	9600 Baud
[3]	19200 Baud
[4]	38400 Baud
[5]	57600 Baud
[6]	76800 Baud
[7]	115200 Baud

8-33 Parity / Stop Bits

Option:	Function:
[0] *	Even Parity, 1 Stop Bit
[1]	Odd Parity, 1 Stop Bit
[2]	No Parity, 1 Stop Bit
[3]	No Parity, 2 Stop Bits

8-34 Estimated cycle time

Range:

0 ms* [0 - 1000000 ms]

Function:

In a noisy environments, the interface may be blocked by due to overload of bad frames. This parameter specifies the time between two consecutive frames on the network. If the interface does not detect valid frames in that time it flushes the receive buffer.

8-35 Minimum Response Delay

Range:

10 ms* [Application dependant]

Function:

Specify the minimum delay time between receiving a request and transmitting a response. This is used for overcoming modem turnaround delays.

8-36 Max Response Delay

Range:
Application [Application dependant]
dependent*
Function:

8-37 Max Inter-Char Delay

Range:
Application [Application dependant]
dependent*
Function:

3.10.5 8-4* FC MC protocol set

8-40 Telegram selection

Option:

[1] * Standard telegram 1

Function:

Enables use of freely configurable messages or standard messages for the FC port.

[200] Custom telegram 1

Enables use of freely configurable telegrams or standard telegrams for the FC port.

8-41 Parameters for signals

Option:

[0] * None

Function:

This parameter contains a list of signals available for selection in par. 8-42 and 8-43.

[302] Minimum Reference

[303] Maximum Reference

[312] Catch up/slow Down Value

[341] Ramp 1 Ramp up Time

[342] Ramp 1 Ramp Down Time

[351] Ramp 2 Ramp up Time

[352] Ramp 2 Ramp down Time

[380] Jog Ramp Time

[381] Quick Stop Ramp Time

[411] Motor Speed Low Limit [RPM]

[412] Motor Speed Low Limit [Hz]

[413] Motor Speed High Limit [RPM]

[414] Motor Speed High Limit [Hz]

[416] Torque Limit Motor Mode

[417] Torque Limit Generator Mode

[590]	Digital & Relay Bus Control
[593]	Pulse Out #27 Bus Control
[595]	Pulse Out #29 Bus Control
[597]	Pulse Out #X30/6 Bus Control
[653]	Terminal 42 Output Bus Control
[663]	Terminal X30/8 Bus Control
[673]	Terminal X45/1 Bus Control
[683]	Terminal X45/3 Bus Control
[890]	Bus Jog 1 Speed
[891]	Bus Jog 2 Speed
[1472]	VLT Alarm Word
[1473]	VLT Warning Word
[1474]	VLT Ext. Status Word
[1500]	Operating Hours
[1501]	Running Hours
[1502]	kWh Counter
[1600]	Control Word
[1601]	Reference [Unit]
[1602]	Reference %
[1603]	Status Word
[1605]	Main Actual Value [%]
[1609]	Custom Readout
[1610]	Power [kW]
[1611]	Power [hp]
[1612]	Motor Voltage
[1613]	Frequency
[1614]	Motor Current
[1615]	Frequency [%]
[1616]	Torque [Nm]
[1617]	Speed [RPM]
[1618]	Motor Thermal
[1619]	KTY sensor temperature
[1620]	Motor Angle
[1622]	Torque [%]
[1625]	Torque [Nm] High
[1630]	DC Link Voltage
[1632]	Brake Energy /s
[1633]	Brake Energy /2 min
[1634]	Heatsink Temp.
[1635]	Inverter Thermal
[1638]	SL Controller State
[1639]	Control Card Temp.
[1650]	External Reference

[1651]	Pulse Reference
[1652]	Feedback [Unit]
[1653]	Digi Pot Reference
[1660]	Digital Input
[1661]	Terminal 53 Switch Setting
[1662]	Analog Input 53
[1663]	Terminal 54 Switch Setting
[1664]	Analog Input 54
[1665]	Analog Output 42 [mA]
[1666]	Digital Output [bin]
[1667]	Freq. Input #29 [Hz]
[1668]	Freq. Input #33 [Hz]
[1669]	Pulse Output #27 [Hz]
[1670]	Pulse Output #29 [Hz]
[1671]	Relay Output [bin]
[1672]	Counter A
[1673]	Counter B
[1674]	Prec. Stop Counter
[1675]	Analog In X30/11
[1676]	Analog In X30/12
[1677]	Analog Out X30/8 [mA]
[1678]	Analog Out X45/1 [mA]
[1679]	Analog Out X45/3 [mA]
[1680]	Fieldbus CTW 1
[1682]	Fieldbus REF 1
[1684]	Comm. Option STW
[1685]	FC Port CTW 1
[1690]	Alarm Word
[1691]	Alarm Word 2
[1692]	Warning Word
[1693]	Warning Word 2
[1694]	Ext. Status Word
[3401]	PCD 1 Write to MCO
[3402]	PCD 2 Write to MCO
[3403]	PCD 3 Write to MCO
[3404]	PCD 4 Write to MCO
[3405]	PCD 5 Write to MCO
[3406]	PCD 6 Write to MCO
[3407]	PCD 7 Write to MCO
[3408]	PCD 8 Write to MCO
[3409]	PCD 9 Write to MCO
[3410]	PCD 10 Write to MCO
[3421]	PCD 1 Read from MCO

[3422]	PCD 2 Read from MCO
[3423]	PCD 3 Read from MCO
[3424]	PCD 4 Read from MCO
[3425]	PCD 5 Read from MCO
[3426]	PCD 6 Read from MCO
[3427]	PCD 7 Read from MCO
[3428]	PCD 8 Read from MCO
[3429]	PCD 9 Read from MCO
[3430]	PCD 10 Read from MCO
[3440]	Digital Inputs
[3441]	Digital Outputs
[3450]	Actual Position
[3451]	Commanded Position
[3452]	Actual Master Position
[3453]	Slave Index Position
[3454]	Master Index Position
[3455]	Curve Position
[3456]	Track Error
[3457]	Synchronizing Error
[3458]	Actual Velocity
[3459]	Actual Master Velocity
[3460]	Synchronizing Status
[3461]	Axis Status
[3462]	Program Status
[3464]	MCO 302 Status
[3465]	MCO 302 Control
[3470]	MCO Alarm Word 1
[3471]	MCO Alarm Word 2

8-42 PCD write configuration

Option:

Function:

[0]	None	Select the parameters to be assigned to PCD messages. The number of available PCDs depends on the message type. The values in the PCDs will then be written to the selected parameters as data values.
[302]	Minimum Reference	
[303]	Maximum Reference	
[312]	Catch up/slow Down Value	
[341]	Ramp 1 Ramp up Time	
[342]	Ramp 1 Ramp Down Time	
[351]	Ramp 2 Ramp up Time	
[352]	Ramp 2 Ramp down Time	
[380]	Jog Ramp Time	
[381]	Quick Stop Ramp Time	
[411]	Motor Speed Low Limit [RPM]	

[412]	Motor Speed Low Limit [Hz]
[413]	Motor Speed High Limit [RPM]
[414]	Motor Speed High Limit [Hz]
[416]	Torque Limit Motor Mode
[417]	Torque Limit Generator Mode
[590]	Digital & Relay Bus Control
[593]	Pulse Out #27 Bus Control
[595]	Pulse Out #29 Bus Control
[597]	Pulse Out #X30/6 Bus Control
[653]	Terminal 42 Output Bus Control
[663]	Terminal X30/8 Bus Control
[673]	Terminal X45/1 Bus Control
[683]	Terminal X45/3 Bus Control
[890]	Bus Jog 1 Speed
[891]	Bus Jog 2 Speed
[1680]	Fieldbus CTW 1
[1682]	Fieldbus REF 1
[3401]	PCD 1 Write to MCO
[3402]	PCD 2 Write to MCO
[3403]	PCD 3 Write to MCO
[3404]	PCD 4 Write to MCO
[3405]	PCD 5 Write to MCO
[3406]	PCD 6 Write to MCO
[3407]	PCD 7 Write to MCO
[3408]	PCD 8 Write to MCO
[3409]	PCD 9 Write to MCO
[3410]	PCD 10 Write to MCO

8-43 PCD read configuration

Option:	Function:
[0] None	Select the parameters to be assigned to PCDs of the messages. The number of available PCDs depends on the message type. PCDs contain the actual data values of the selected parameters.
[1472]	VLT Alarm Word
[1473]	VLT Warning Word
[1474]	VLT Ext. Status Word
[1500]	Operating Hours
[1501]	Running Hours
[1502]	kWh Counter
[1600]	Control Word
[1601]	Reference [Unit]
[1602]	Reference %
[1603]	Status Word
[1605]	Main Actual Value [%]
[1609]	Custom Readout

[1610]	Power [kW]
[1611]	Power [hp]
[1612]	Motor Voltage
[1613]	Frequency
[1614]	Motor Current
[1615]	Frequency [%]
[1616]	Torque [Nm]
[1617]	Speed [RPM]
[1618]	Motor Thermal
[1619]	KTY sensor temperature
[1620]	Motor Angle
[1622]	Torque [%]
[1625]	Torque [Nm] High
[1630]	DC Link Voltage
[1632]	Brake Energy /s
[1633]	Brake Energy /2 min
[1634]	Heatsink Temp.
[1635]	Inverter Thermal
[1638]	SL Controller State
[1639]	Control Card Temp.
[1650]	External Reference
[1651]	Pulse Reference
[1652]	Feedback [Unit]
[1653]	Digi Pot Reference
[1660]	Digital Input
[1661]	Terminal 53 Switch Setting
[1662]	Analog Input 53
[1663]	Terminal 54 Switch Setting
[1664]	Analog Input 54
[1665]	Analog Output 42 [mA]
[1666]	Digital Output [bin]
[1667]	Freq. Input #29 [Hz]
[1668]	Freq. Input #33 [Hz]
[1669]	Pulse Output #27 [Hz]
[1670]	Pulse Output #29 [Hz]
[1671]	Relay Output [bin]
[1672]	Counter A
[1673]	Counter B
[1674]	Prec. Stop Counter
[1675]	Analog In X30/11
[1676]	Analog In X30/12
[1677]	Analog Out X30/8 [mA]
[1678]	Analog Out X45/1 [mA]

[1679]	Analog Out X45/3 [mA]
[1684]	Comm. Option STW
[1685]	FC Port CTW 1
[1690]	Alarm Word
[1691]	Alarm Word 2
[1692]	Warning Word
[1693]	Warning Word 2
[1694]	Ext. Status Word
[3421]	PCD 1 Read from MCO
[3422]	PCD 2 Read from MCO
[3423]	PCD 3 Read from MCO
[3424]	PCD 4 Read from MCO
[3425]	PCD 5 Read from MCO
[3426]	PCD 6 Read from MCO
[3427]	PCD 7 Read from MCO
[3428]	PCD 8 Read from MCO
[3429]	PCD 9 Read from MCO
[3430]	PCD 10 Read from MCO
[3440]	Digital Inputs
[3441]	Digital Outputs
[3450]	Actual Position
[3451]	Commanded Position
[3452]	Actual Master Position
[3453]	Slave Index Position
[3454]	Master Index Position
[3455]	Curve Position
[3456]	Track Error
[3457]	Synchronizing Error
[3458]	Actual Velocity
[3459]	Actual Master Velocity
[3460]	Synchronizing Status
[3461]	Axis Status
[3462]	Program Status
[3464]	MCO 302 Status
[3465]	MCO 302 Control
[3470]	MCO Alarm Word 1
[3471]	MCO Alarm Word 2

3.10.6 8-5* Digital/Bus

Parameters for configuring the control word Digital/Bus merging.

8-50 Coasting Select

Option:

Function:

		Select control of the coasting function via the terminals (digital input) and/or via the bus.
[0]	Digital input	Activates Start command via a digital input.
[1]	Bus	Activates Start command via the serial communication port or serial communication option.
[2]	Logic AND	Activates Start command via the serial communication bus/serial communication port, AND additionally via one of the digital inputs.
[3] *	Logic OR	Activates Start command via the serial communication bus/serial communication port OR via one of the digital inputs.



NOTE!

This parameter is active only when par. 8-01 *Control Site* is set to [0] *Digital and control word*.

8-51 Quick Stop Select

Select control of the quick stop function via the terminals (digital input) and/or via the bus.

Option:

Function:

[0]	Digital Input	
[1]	Bus	
[2]	Logic AND	
[3] *	Logic OR	



NOTE!

This parameter is active only when par. 8-01 *Control Site* is set to [0] *Digital and control word*.

8-52 DC Brake Select

Option:

Function:

		Select control of the DC brake via the terminals (digital input) and/or via the serial communication bus.
[0]	Digital input	Activates Start command via a digital input.
[1]	Bus	Activates Start command via the serial communication port or serial communication option.
[2]	Logic AND	Activates Start command via the serial communication bus/serial communication port, AND additionally via one of the digital inputs.
[3] *	Logic OR	Activates Start command via the serial communication bus/serial communication port OR via one of the digital inputs.



NOTE!

This parameter is active only when par. 8-01 *Control Site* is set to [0] *Digital and control word*.

8-53 Start Select

Option:	Function:
	Select control of the adjustable frequency drive start function via the terminals (digital input) and/or via the serial communication bus.
[0] Digital input	Activates Start command via a digital input.
[1] Bus	Activates Start command via the serial communication port or serial communication option.
[2] Logic AND	Activates Start command via the serial communication bus/serial communication port, AND additionally via one of the digital inputs.
[3] * Logic OR	Activates Start command via the serial communication bus/serial communication port OR via one of the digital inputs.

NOTE!

This parameter is active only when par. 8-01 *Control Site* is set to [0] *Digital and control word*.

8-54 Reverse Select

Option:	Function:
	Select control of the adjustable frequency drive reverse function via the terminals (digital input) and/or via the serial communication bus.
[0] Digital input	Select control of the adjustable frequency drive reverse function via the terminals (digital input) and/or via the serial communication bus.
[1] Bus	Activates the reverse command via the serial communication port or serial communication option.
[2] Logic AND	Activates the reverse command via the serial communication bus/serial communication port, AND additionally via one of the digital inputs.
[3] * Logic OR	Activates the reverse command via the serial communication bus/serial communication port OR via one of the digital inputs.

NOTE!

This parameter is only active when par. 8-01 *Control Site* is set to [0] *Digital and control word*.

8-55 Set-up Select

Option:	Function:
	Select control of the adjustable frequency drive set-up selection via the terminals (digital input) and/or via the serial communication bus.
[0] Digital input	Activates the set-up selection via a digital input.
[1] Bus	Activates the set-up selection via the serial communication port or serial communication option.
[2] Logic AND	Activates the set-up selection via the serial communication bus/serial communication port, AND additionally via one of the digital inputs.
[3] * Logic OR	Activate the set-up selection via the serial communication bus/serial communication port OR via one of the digital inputs.



NOTE!

This parameter is active only when par. 8-01 *Control Site* is set to [0] *Digital and control word*.

8-56 Preset Reference Select

Option:

Function:

Select control of the adjustable frequency drive Preset Reference selection via the terminals (digital input) and/or via the serial communication bus.

[0] Digital input

Activates Preset Reference selection via a digital input.

[1] Bus

Activates Preset Reference selection via the serial communication port or serial communication option.

[2] Logic AND

Activates Preset Reference selection via the serial communication bus/serial communication port, AND additionally via one of the digital inputs.

[3] * Logic OR

Activates the Preset Reference selection via the serial communication bus/serial communication port OR via one of the digital inputs.

3



NOTE!

This parameter is active only when par. 8-01 *Control Site* is set to [0] *Digital and control word*.

3.10.7 8-8* Adjustable Frequency Drive Port Diagnostics

These parameters are used for monitoring the bus communication via the Adjustable Frequency Drive Port.

8-80 Bus Message Count

Range:

0 N/A* [0 - 0 N/A]

Function:

This parameter shows the number of valid messages detected on the bus.

8-81 Bus Error Count

Range:

0 N/A* [0 - 0 N/A]

Function:

This parameter shows the number of messages with faults (e.g., CRC fault), detected on the bus.

8-82 Slave Messages Rcvd

Range:

0 N/A* [0 - 0 N/A]

Function:

This parameter shows the number of valid messages addressed to the slave, sent by the adjustable frequency drive.

8-83 Slave Error Count

Range:

0 N/A* [0 - 0 N/A]

Function:

This parameter shows the number of error messages, which could not be executed by the adjustable frequency drive.

3.10.8 8-9* Bus Jog

Parameters for configuring the Bus Jog.

8-90 Bus Jog 1 Speed

Range:	Function:
100 RPM* [Application dependant]	Enter the jog speed. This is a fixed jog speed activated via the serial port or serial communication bus option.

8-91 Bus Jog 2 Speed

Range:	Function:
200 RPM* [Application dependant]	Enter the jog speed. This is a fixed jog speed activated via the serial port or serial communication bus option.

3.11 Parameters: Profibus

3.11.1 9-** Profibus

Parameter group for all Profibus-specific parameters.

9-00 Setpoint

Range:	Function:
0* [0 - 65535]	This parameter receives cyclical reference from a Master Class 2. If the control priority is set to Master Class 2, the reference for the adjustable frequency drive is taken from this parameter, whereas the cyclical reference will be ignored.

9-07 Actual Value

Range:	Function:
0* [0 - 65535]	This parameter delivers the MAV for a Master Class 2. The parameter is valid if the control priority is set to Master Class 2.

9-15 PCD Write Configuration

Array [10]

Option:	Function:
	Select the parameters to be assigned to PCD 3 to 10 of the messages. The number of available PCDs depends on the message type. The values in PCD 3 to 10 will then be written to the selected parameters as data values. Alternatively, specify a standard Profibus message in par. 9-22 <i>Telegram Selection</i> .

[0] *	None
[302]	Minimum Reference
[303]	Maximum Reference
[312]	Catch up/slow-down Value
[341]	Ramp 1 Ramp-up Time
[342]	Ramp 1 Ramp-down Time
[351]	Ramp 2 Ramp-up Time
[352]	Ramp 2 Ramp-down Time
[380]	Jog Ramp Time
[381]	Quick Stop Ramp Time

- [411] Motor Speed Low Limit [RPM]
- [412] Motor Speed Low Limit [Hz]
- [413] Motor Speed High Limit [RPM]
- [414] Motor Speed High Limit [Hz]
- [416] Torque Limit Motor Mode
- [417] Torque Limit Generator Mode
- [590] Digital & Relay Bus Control
- [593] Pulse Out #27 Bus Control
- [595] Pulse Out #29 Bus Control
- [597] Pulse Out #X30/6 Bus Control
- [653] Terminal 42 Output Bus Control
- [663] Terminal X30/8 Bus Control
- [673] Terminal X45/1 Bus Control
- [683] Terminal X45/3 Bus Control
- [890] Bus Jog 1 Speed
- [891] Bus Jog 2 Speed
- [1293] Cable Error Length
- [1680] Fieldbus CTW 1
- [1682] Fieldbus REF 1
- [3401] PCD 1 Write to MCO
- [3402] PCD 2 Write to MCO
- [3403] PCD 3 Write to MCO
- [3404] PCD 4 Write to MCO
- [3405] PCD 5 Write to MCO
- [3406] PCD 6 Write to MCO
- [3407] PCD 7 Write to MCO
- [3408] PCD 8 Write to MCO
- [3409] PCD 9 Write to MCO
- [3410] PCD 10 Write to MCO

9-16 PCD Read Configuration

Array [10]

Option:

Function:

Select the parameters to be assigned to PCD 3 to 10 of the messages. The number of available PCDs depends on the message type. PCDs 3 to 10 contain the actual data values of the selected parameters. For standard Profibus messages, see par. 9-22 *Telegram Selection*.

[0] * None

[1472] VLT Alarm Word

[1473] VLT Warning Word

[1474] VLT Ext. Status Word

[1500] Operating Hours

[1501] Running Hours

[1502] kWh Counter

[1600] Control Word

[1601]	Reference [Unit]
[1602]	Reference %
[1603]	Status Word
[1605]	Main Actual Value [%]
[1609]	Custom Readout
[1610]	Power [kW]
[1611]	Power [hp]
[1612]	Motor voltage
[1613]	Frequency
[1614]	Motor Current
[1615]	Frequency [%]
[1616]	Torque [Nm]
[1617]	Speed [RPM]
[1618]	Motor Thermal
[1619]	KTY sensor temperature
[1620]	Motor Angle
[1622]	Torque [%]
[1625]	Torque [Nm] High
[1630]	DC Link Voltage
[1632]	Brake Energy /s
[1633]	Brake Energy /2 min
[1634]	Heatsink Temp.
[1635]	Inverter Thermal
[1638]	SL Controller State
[1639]	Control Card Temp.
[1650]	External Reference
[1651]	Pulse Reference
[1652]	Feedback [Unit]
[1653]	Digi Pot Reference
[1660]	Digital Input
[1661]	Terminal 53 Switch Setting
[1662]	Analog Input 53
[1663]	Terminal 54 Switch Setting
[1664]	Analog Input 54
[1665]	Analog Output 42 [mA]
[1666]	Digital Output [bin]
[1667]	Freq. Input #29 [Hz]
[1668]	Freq. Input #33 [Hz]
[1669]	Pulse Output #27 [Hz]
[1670]	Pulse Output #29 [Hz]
[1671]	Relay Output [bin]
[1672]	Counter A
[1673]	Counter B

[1674]	Prec. Stop Counter
[1675]	Analog In X30/11
[1676]	Analog In X30/12
[1677]	Analog Out X30/8 [mA]
[1678]	Analog Out X45/1 [mA]
[1679]	Analog Out X45/3 [mA]
[1684]	Comm. Option Status
[1685]	FC Port CTW 1
[1690]	Alarm Word
[1691]	Alarm word 2
[1692]	Warning Word
[1693]	Warning word 2
[1694]	Ext. Status Word
[3421]	PCD 1 Read from MCO
[3422]	PCD 2 Read from MCO
[3423]	PCD 3 Read from MCO
[3424]	PCD 4 Read from MCO
[3425]	PCD 5 Read from MCO
[3426]	PCD 6 Read from MCO
[3427]	PCD 7 Read from MCO
[3428]	PCD 8 Read from MCO
[3429]	PCD 9 Read from MCO
[3430]	PCD 10 Read from MCO
[3440]	Digital Inputs
[3441]	Digital Outputs
[3450]	Actual Position
[3451]	Commanded Position
[3452]	Actual Master Position
[3453]	Slave Index Position
[3454]	Master Index Position
[3455]	Curve Position
[3456]	Track Error
[3457]	Synchronizing Error
[3458]	Actual Velocity
[3459]	Actual Master Velocity
[3460]	Synchronizing Status
[3461]	Axis Status
[3462]	Program Status
[3464]	MCO 302 Status
[3465]	MCO 302 Control
[3470]	MCO Alarm Word 1
[3471]	MCO Alarm Word 2

9-18 Node Address**Range:**

126 N/A* [Application dependant]

Function:

Enter the station address in this parameter or alternatively in the hardware switch. In order to adjust the station address in par. 9-18 *Node Address*, the hardware switch must be set to 126 or 127 (i.e., all switches set to 'on'). Otherwise, this parameter will display the actual setting of the switch.

9-22 Telegram Selection

Displays the Profibus message configuration.

Option:

[1] Standard telegram 1

[101] PPO 1

[102] PPO 2

[103] PPO 3

[104] PPO 4

[105] PPO 5

[106] PPO 6

[107] PPO 7

[108] * PPO 8

Read only.

[200] Custom telegram 1

9-23 Parameters for Signals

Array [1000]

Read only

Option:**Function:**

This parameter contains a list of signals available for selection in par. 9-15 *PCD Write Configuration* and par. 9-16 *PCD Read Configuration*.

[0] * None

[302] Minimum Reference

[303] Maximum Reference

[312] Catch up/slow-down Value

[341] Ramp 1 Ramp-up Time

[342] Ramp 1 Ramp-down Time

[351] Ramp 2 Ramp-up Time

[352] Ramp 2 Ramp-down Time

[380] Jog Ramp Time

[381] Quick Stop Ramp Time

[411] Motor Speed Low Limit [RPM]

[412] Motor Speed Low Limit [Hz]

[413] Motor Speed High Limit [RPM]

[414] Motor Speed High Limit [Hz]

[416] Torque Limit Motor Mode

[417] Torque Limit Generator Mode

[590] Digital & Relay Bus Control

[593] Pulse Out #27 Bus Control

[595] Pulse Out #29 Bus Control

[597]	Pulse Out #X30/6 Bus Control
[653]	Terminal 42 Output Bus Control
[663]	Terminal X30/8 Bus Control
[673]	Terminal X45/1 Bus Control
[683]	Terminal X45/3 Bus Control
[890]	Bus Jog 1 Speed
[891]	Bus Jog 2 Speed
[1293]	Cable Error Length
[1472]	VLT Alarm Word
[1473]	VLT Warning Word
[1474]	VLT Ext. Status Word
[1500]	Operating Hours
[1501]	Running Hours
[1502]	kWh Counter
[1600]	Control Word
[1601]	Reference [Unit]
[1602]	Reference %
[1603]	Status Word
[1605]	Main Actual Value [%]
[1609]	Custom Readout
[1610]	Power [kW]
[1611]	Power [hp]
[1612]	Motor voltage
[1613]	Frequency
[1614]	Motor Current
[1615]	Frequency [%]
[1616]	Torque [Nm]
[1617]	Speed [RPM]
[1618]	Motor Thermal
[1619]	KTY sensor temperature
[1620]	Motor Angle
[1622]	Torque [%]
[1625]	Torque [Nm] High
[1630]	DC Link Voltage
[1632]	Brake Energy /s
[1633]	Brake Energy /2 min
[1634]	Heatsink Temp.
[1635]	Inverter Thermal
[1638]	SL Controller State
[1639]	Control Card Temp.
[1650]	External Reference
[1651]	Pulse Reference
[1652]	Feedback [Unit]

[1653]	Digi Pot Reference
[1660]	Digital Input
[1661]	Terminal 53 Switch Setting
[1662]	Analog Input 53
[1663]	Terminal 54 Switch Setting
[1664]	Analog Input 54
[1665]	Analog Output 42 [mA]
[1666]	Digital Output [bin]
[1667]	Freq. Input #29 [Hz]
[1668]	Freq. Input #33 [Hz]
[1669]	Pulse Output #27 [Hz]
[1670]	Pulse Output #29 [Hz]
[1671]	Relay Output [bin]
[1672]	Counter A
[1673]	Counter B
[1674]	Prec. Stop Counter
[1675]	Analog In X30/11
[1676]	Analog In X30/12
[1677]	Analog Out X30/8 [mA]
[1678]	Analog Out X45/1 [mA]
[1679]	Analog Out X45/3 [mA]
[1680]	Fieldbus CTW 1
[1682]	Fieldbus REF 1
[1684]	Comm. Option Status
[1685]	FC Port CTW 1
[1690]	Alarm Word
[1691]	Alarm word 2
[1692]	Warning Word
[1693]	Warning word 2
[1694]	Ext. Status Word
[3401]	PCD 1 Write to MCO
[3402]	PCD 2 Write to MCO
[3403]	PCD 3 Write to MCO
[3404]	PCD 4 Write to MCO
[3405]	PCD 5 Write to MCO
[3406]	PCD 6 Write to MCO
[3407]	PCD 7 Write to MCO
[3408]	PCD 8 Write to MCO
[3409]	PCD 9 Write to MCO
[3410]	PCD 10 Write to MCO
[3421]	PCD 1 Read from MCO
[3422]	PCD 2 Read from MCO
[3423]	PCD 3 Read from MCO

[3424]	PCD 4 Read from MCO
[3425]	PCD 5 Read from MCO
[3426]	PCD 6 Read from MCO
[3427]	PCD 7 Read from MCO
[3428]	PCD 8 Read from MCO
[3429]	PCD 9 Read from MCO
[3430]	PCD 10 Read from MCO
[3440]	Digital Inputs
[3441]	Digital Outputs
[3450]	Actual Position
[3451]	Commanded Position
[3452]	Actual Master Position
[3453]	Slave Index Position
[3454]	Master Index Position
[3455]	Curve Position
[3456]	Track Error
[3457]	Synchronizing Error
[3458]	Actual Velocity
[3459]	Actual Master Velocity
[3460]	Synchronizing Status
[3461]	Axis Status
[3462]	Program Status
[3464]	MCO 302 Status
[3465]	MCO 302 Control
[3470]	MCO Alarm Word 1
[3471]	MCO Alarm Word 2

9-27 Parameter Edit

Option:	Function:
	Parameters can be edited via Profibus, the standard RS485 interface, or the LCP.
[0]	Disabled Disables editing via Profibus.
[1] *	Enabled Enables editing via Profibus.

9-28 Process Control

Option:	Function:
	Process control (setting of the control word, speed reference, and process data) is possible via either Profibus or standard serial communication bus but not both simultaneously. Local control is always possible via the LCP. Control via process control is possible via either terminals or serial communication bus depending on the settings in par. 8-50 <i>Coasting Select</i> to par. 8-56 <i>Preset Reference Select</i> .
[0]	Disable Disables process control via Profibus, and enables process control via standard serial communication bus or Profibus Master class 2.
[1] *	Enable cyclic master Enables process control via Profibus Master Class 1, and disables process control via standard serial communication bus or Profibus Master class 2.

9-44 Fault Message Counter**Range:**

0* [0 - 65535]

Function:

This parameter displays the number of error events stored in par. 9-45 *Fault Code* and par. 9-47 *Fault Number*. The maximum buffer capacity is eight error events. The buffer and counter are set to 0 upon reset or power-up.

9-45 Fault Code**Range:**

0* [0 - 0]

Function:

This buffer contains the alarm word for all alarms and warnings that have occurred since the last reset or power-up. The maximum buffer capacity is eight error events.

9-47 Fault Number**Range:**

0* [0 - 0]

Function:

This buffer contains the alarm number (e.g., 2 for live zero error, 4 for line phase loss) for all alarms and warnings that have occurred since last reset or power-up. The maximum buffer capacity is eight error events.

9-52 Fault Situation Counter**Range:**

0* [0 - 1000]

Function:

This parameter displays the number of error events which have occurred since the last reset of power-up.

9-53 Profibus Warning Word**Range:**

0 N/A* [0 - 65535 N/A]

Function:

This parameter displays Profibus communication warnings. Please refer to the *Profibus Instruction Manual* for further information.

Read only

Bit:	Meaning:
0	Connection with DP master is not ok
1	Not used
2	FDLNDL (Serial Communication Bus Data link Layer) is not ok
3	Clear data command received
4	The actual value is not updated
5	Baud rate search
6	PROFIBUS ASIC is not transmitting
7	Initialization of PROFIBUS is not ok
8	The adjustable frequency drive is tripped.
9	Internal CAN error
10	Wrong configuration data from PLC
11	Wrong ID sent by PLC
12	Internal error occurred
13	Not configured
14	Timeout active
15	Warning 34 active

9-63 Actual Baud Rate

Option:	Function:
	This parameter displays the actual Profibus baud rate. The Profibus Master automatically sets the baud rate.
[0]	9.6 kbit/s
[1]	19.2 kbit/s
[2]	93.75 kbit/s
[3]	187.5 kbit/s
[4]	500 kbit/s
[6]	1500 kbit/s
[7]	3000 kbit/s
[8]	6000 kbit/s
[9]	12000 kbit/s
[10]	31.25 kbit/s
[11]	45.45 kbit/s
[255] *	No baud rate found

9-64 Device Identification

Range:	Function:
0* [0 - 0]	This parameter displays the device identification. Please refer to the <i>Instruction Manual for Profibus</i> , MG.33.CX.YY for further explanation.

9-65 Profile Number

Range:	Function:
0 N/A* [0 - 0 N/A]	This parameter contains the profile identification. Byte 1 contains the profile number and byte 2 the version number of the profile.

NOTE!
This parameter is not visible via LCP.

9-67 Control Word 1

Range:	Function:
0* [0 - 65535]	This parameter accepts the control word from a Master Class 2 in the same format as PCD 1.

9-68 Status Word 1

Range:	Function:
0* [0 - 65535]	This parameter delivers the status word for a Master Class 2 in the same format as PCD 2.

9-70 Programming Set-up

Option:	Function:
	Select the set-up to be edited.
[0]	Factory setup Uses default data. This option can be used as a data source to return the other set-ups to a known state.
[1]	Set-up 1 Edits Set-up 1.

[2]	Set-up 2	Edits Set-up 2.
[3]	Set-up 3	Edits Set-up 3.
[4]	Set-up 4	Edits Set-up 4.
[9] *	Active Set-up	Follows the active set-up selected in par. 0-10 <i>Active Set-up</i> .

This parameter is unique to LCP and serial communication busses. See also par. 0-11 *Programming Set-up*.

3

9-71 Profibus Save Data Values

Option:	Function:
	Parameter values changed via Profibus are not automatically stored in non-volatile memory. Use this parameter to activate a function that stores parameter values in the EEPROM non-volatile memory, so changed parameter values will be retained at power-down.
[0] * Off	Deactivates the non-volatile storage function.
[1] Store edit setup	Stores all parameter values for all set-ups in the non-volatile memory. The selection returns to <i>Off</i> [0] when all parameter values have been stored.
[2] Store all setups	Stores all parameter values for all set-ups in the non-volatile memory. The selection returns to <i>Off</i> [0] when all parameter values have been stored.

9-72 ProfibusDriveReset

Option:	Function:
[0] * No action	
[1] Power-on reset	Resets the adjustable frequency drive upon power-up, as for power-cycle.
[3] Comm option reset	Resets the Profibus option only, useful after changing certain settings in parameter group 9-**, e.g., par. 9-18 <i>Node Address</i> . When reset, the adjustable frequency drive disappears from the serial communication bus, which may cause a communication error from the master.

9-80 Defined Parameters (1)

Array [116]
No LCP access
Read only

Range:	Function:
0 N/A* [0 - 9999 N/A]	This parameter displays a list of all the defined adjustable frequency drive parameters available for Profibus.

9-81 Defined Parameters (2)

Array [116]
No LCP access
Read only

Range:	Function:
0 N/A* [0 - 9999 N/A]	This parameter displays a list of all the defined adjustable frequency drive parameters available for Profibus.

9-82 Defined Parameters (3)

Array [116]
 No LCP access
 Read only

Range:

0 N/A* [0 - 9999 N/A]

Function:

This parameter displays a list of all the defined adjustable frequency drive parameters available for Profibus.

9-83 Defined Parameters (4)

Array [116]
 No LCP access
 Read only

Range:

0 N/A* [0 - 9999 N/A]

Function:

This parameter displays a list of all the defined adjustable frequency drive parameters available for Profibus.

9-84 Defined Parameters (5)

Range:

0* [0 - 9999]

Function:

This parameter displays a list of all the defined adjustable frequency drive parameters available for Profibus.

9-90 Changed Parameters (1)

Array [116]
 No LCP access
 Read only

Range:

0 N/A* [0 - 9999 N/A]

Function:

This parameter displays a list of all the adjustable frequency drive parameters deviating from default setting.

9-91 Changed Parameters (2)

Array [116]
 No LCP access
 Read only

Range:

0 N/A* [0 - 9999 N/A]

Function:

This parameter displays a list of all the adjustable frequency drive parameters deviating from default setting.

9-92 Changed Parameters (3)

Array [116]
 No LCP access
 Read only

Range:

0 N/A* [0 - 9999 N/A]

Function:

This parameter displays a list of all the adjustable frequency drive parameters deviating from default setting.

9-94 Changed parameters (5)

Array [116]

No LCP Address

Read only

Range:

0 N/A* [0 - 9999 N/A]

Function:

This parameter displays a list of all the adjustable frequency drive parameters deviating from default setting.

3.12 Parameters: DeviceNet CAN Serial Communication Bus

3.12.1 10-** DeviceNet and CAN serial communication bus

Parameter group for DeviceNet CAN serial communication bus parameters.

3.12.2 10-0* Common Settings

Parameter group for configuring common settings for CAN serial communication bus options.

10-00 CAN Protocol

Option:

[0] CANopen

Function:

[1] * DeviceNet

View the active CAN protocol.

**NOTE!**

The options depend on installed option.

10-01 Baud Rate Select

Select the serial communication bus transmission speed. The selection must correspond to the transmission speed of the master and the other serial communication bus nodes.

Option:

[16] 10 Kbps

[17] 20 Kbps

[18] 50 Kbps

[19] 100 Kbps

[20] * 125 Kbps

[21] 250 Kbps

[22] 500 Kbps

Function:

10-02 MAC ID

Range:Application [Application dependant]
dependent***Function:**

10-05 Readout Transmit Error Counter

Range:

0 N/A* [0 - 255 N/A]

Function:

View the number of CAN control transmission errors since the last power-up.

10-06 Readout Receive Error Counter

Range:	Function:
0 N/A* [0 - 255 N/A]	View the number of CAN control receipt errors since the last power-up.

10-07 Readout Bus Off Counter

Range:	Function:
0* [0 - 255]	View the number of bus-off events since the last power-up.

3.12.3 10-1* DeviceNet

Parameters specific to the DeviceNet serial communication bus.

10-10 Process Data Type Selection

Option:	Function:
	Select the Instance (message) for data transmission. The instances available are dependent upon the setting of par. 8-10 <i>Control Profile</i> . When par. 8-10 <i>Control Profile</i> is set to [0] <i>FC profile</i> , par. 10-10 <i>Process Data Type Selection</i> options [0] and [1] are available. When par. 8-10 <i>Control Profile</i> is set to [5] <i>ODVA</i> , par. 10-10 <i>Process Data Type Selection</i> options [2] and [3] are available. Instances 100/150 and 101/151 are Danfoss-specific. Instances 20/70 and 21/71 are ODVA-specific AC Drive profiles. For guidelines in message selection, please refer to the DeviceNet Instruction Manual. Note that a change to this parameter will be executed immediately.

[0] *	INSTANCE 100/150
[1]	INSTANCE 101/151
[2]	INSTANCE 20/70
[3]	INSTANCE 21/71

10-11 Process Data Config Write

Select the process write data for I/O assembly instances 101/151. Elements [2] and [3] of this array can be selected. Elements [0] and [1] of the array are fixed.

Option:	Function:
[0] *	None
[302]	Minimum Reference
[303]	Maximum Reference
[312]	Catch up/slow-down Value
[341]	Ramp 1 Ramp-up Time
[342]	Ramp 1 Ramp-down Time
[351]	Ramp 2 Ramp-up Time
[352]	Ramp 2 Ramp-down Time
[380]	Jog Ramp Time
[381]	Quick Stop Ramp Time
[411]	Motor Speed Low Limit [RPM]
[412]	Motor Speed Low Limit [Hz]
[413]	Motor Speed High Limit [RPM]
[414]	Motor Speed High Limit [Hz]

[416]	Torque Limit Motor Mode
[417]	Torque Limit Generator Mode
[590]	Digital & Relay Bus Control
[593]	Pulse Out #27 Bus Control
[595]	Pulse Out #29 Bus Control
[597]	Pulse Out #X30/6 Bus Control
[653]	Terminal 42 Output Bus Control
[663]	Terminal X30/8 Bus Control
[673]	Terminal X45/1 Bus Control
[683]	Terminal X45/3 Bus Control
[890]	Bus Jog 1 Speed
[891]	Bus Jog 2 Speed
[1293]	Cable Error Length
[1680]	Fieldbus CTW 1
[1682]	Fieldbus REF 1
[3401]	PCD 1 Write to MCO
[3402]	PCD 2 Write to MCO
[3403]	PCD 3 Write to MCO
[3404]	PCD 4 Write to MCO
[3405]	PCD 5 Write to MCO
[3406]	PCD 6 Write to MCO
[3407]	PCD 7 Write to MCO
[3408]	PCD 8 Write to MCO
[3409]	PCD 9 Write to MCO
[3410]	PCD 10 Write to MCO

10-12 Process Data Config Read

Select the process read data for I/O assembly instances 101/151. Elements [2] and [3] of this array can be selected. Elements [0] and [1] of the array are fixed.

Option:

Function:

[0] *	None
[1472]	VLT Alarm Word
[1473]	VLT Warning Word
[1474]	VLT Ext. Status Word
[1500]	Operating Hours
[1501]	Running Hours
[1502]	kWh Counter
[1600]	Control Word
[1601]	Reference [Unit]
[1602]	Reference %
[1603]	Status Word
[1605]	Main Actual Value [%]
[1609]	Custom Readout
[1610]	Power [kW]

[1611]	Power [hp]
[1612]	Motor voltage
[1613]	Frequency
[1614]	Motor Current
[1615]	Frequency [%]
[1616]	Torque [Nm]
[1617]	Speed [RPM]
[1618]	Motor Thermal
[1619]	KTY sensor temperature
[1620]	Motor Angle
[1622]	Torque [%]
[1625]	Torque [Nm] High
[1630]	DC Link Voltage
[1632]	Brake Energy /s
[1633]	Brake Energy /2 min
[1634]	Heatsink Temp.
[1635]	Inverter Thermal
[1638]	SL Controller State
[1639]	Control Card Temp.
[1650]	External Reference
[1651]	Pulse Reference
[1652]	Feedback [Unit]
[1653]	Digi Pot Reference
[1660]	Digital Input
[1661]	Terminal 53 Switch Setting
[1662]	Analog Input 53
[1663]	Terminal 54 Switch Setting
[1664]	Analog Input 54
[1665]	Analog Output 42 [mA]
[1666]	Digital Output [bin]
[1667]	Freq. Input #29 [Hz]
[1668]	Freq. Input #33 [Hz]
[1669]	Pulse Output #27 [Hz]
[1670]	Pulse Output #29 [Hz]
[1671]	Relay Output [bin]
[1672]	Counter A
[1673]	Counter B
[1674]	Prec. Stop Counter
[1675]	Analog In X30/11
[1676]	Analog In X30/12
[1677]	Analog Out X30/8 [mA]
[1678]	Analog Out X45/1 [mA]
[1679]	Analog Out X45/3 [mA]

[1684]	Comm. Option Status
[1685]	FC Port CTW 1
[1690]	Alarm Word
[1691]	Alarm word 2
[1692]	Warning Word
[1693]	Warning word 2
[1694]	Ext. Status Word
[3421]	PCD 1 Read from MCO
[3422]	PCD 2 Read from MCO
[3423]	PCD 3 Read from MCO
[3424]	PCD 4 Read from MCO
[3425]	PCD 5 Read from MCO
[3426]	PCD 6 Read from MCO
[3427]	PCD 7 Read from MCO
[3428]	PCD 8 Read from MCO
[3429]	PCD 9 Read from MCO
[3430]	PCD 10 Read from MCO
[3440]	Digital Inputs
[3441]	Digital Outputs
[3450]	Actual Position
[3451]	Commanded Position
[3452]	Actual Master Position
[3453]	Slave Index Position
[3454]	Master Index Position
[3455]	Curve Position
[3456]	Track Error
[3457]	Synchronizing Error
[3458]	Actual Velocity
[3459]	Actual Master Velocity
[3460]	Synchronizing Status
[3461]	Axis Status
[3462]	Program Status
[3464]	MCO 302 Status
[3465]	MCO 302 Control
[3470]	MCO Alarm Word 1
[3471]	MCO Alarm Word 2

10-13 Warning Parameter

Range:

0* [0 - 65535]

Function:

View a DeviceNet-specific warning word. One bit is assigned to every warning. Please refer to the DeviceNet Instruction Manual (MG.33.DX.YY) for further information.

Bit:	Meaning:
0	BusNetwork not active
1	Explicit connection timeout
2	I/O connection
3	Retry limit reached
4	Actual is not updated
5	CAN bus off
6	I/O send error
7	Initialization error
8	No bus supply
9	Bus off
10	Error passive
11	Error warning
12	Duplicate MAC ID Error
13	RX queue overrun
14	TX queue overrun
15	CAN overrun

10-14 Net Reference

Read only from LCP

Option:

Function:

		Select the reference source in instance 21/71 and 20/70.
[0] *	Off	Enables reference via analog/digital inputs.
[1]	On	Enables reference via the serial communication bus.

10-15 Net Control

Read only from LCP

Option:

Function:

		Select the control source in Instance 21/71 and 20/70.
[0] *	Off	Enables control via analog/digital inputs.
[1]	On	Enable control via the serial communication bus.

3.12.4 10-2* COS Filters

Parameters for configuring COS filter settings.

10-20 COS Filter 1

Range:

Function:

0*	[0 - 65535]	Enter the value for COS Filter 1 to set up the filter mask for the status word. When operating in COS (Change-Of-State), this function filters out bits in the status word that should not be sent if they change.
----	--------------	--

10-21 COS Filter 2

Range:

Function:

0*	[0 - 65535]	Enter the value for COS Filter 2, to set up the filter mask for the Main Actual Value. When operating in COS (Change-Of-State), this function filters out bits in the Main Actual Value that should not be sent if they change.
----	--------------	---

10-22 COS Filter 3

Range:

0* [0 - 65535]

Function:

Enter the value for COS Filter 3, to set up the filter mask for PCD 3. When operating in COS (Change-Of-State), this function filters out bits in PCD 3 that should not be sent if they change.

10-23 COS Filter 4

Range:

0* [0 - 65535]

Function:

Enter the value for COS Filter 4 to set up the filter mask for PCD 4. When operating in COS (Change-Of-State), this function filters out bits in PCD 4 that should not be sent if they change.

3.12.5 10-3* Parameter Access

Parameter group providing access to indexed parameters and defining programming set-up.

10-30 Array Index

Range:

0* [0 - 255]

Function:

View array parameters. This parameter is valid only when a DeviceNet serial communication bus is installed.

10-31 Store Data Values

Option:

[0] * Off

Function:

Parameter values changed via DeviceNet are not automatically stored in non-volatile memory. Use this parameter to activate a function that stores parameter values in the EEPROM non-volatile memory, so that changed parameter values will be retained at power-down.

[1] Store edit setup

Stores all parameter values from the active set-up in the non-volatile memory. The selection returns to Off [0] when all values have been stored.

[2] Store all setups

Stores all parameter values for all set-ups in the non-volatile memory. The selection returns to Off [0] when all parameter values have been stored.

10-32 Devicenet Revision

Range:
Application [0 - 65535]
dependent*
Function:

View the DeviceNet revision number. This parameter is used for EDS file creation.

10-33 Store Always

Option:

[0] * Off

Function:

Deactivates non-volatile storage of data.

[1] On

Stores parameter data received via DeviceNet in EEPROM non-volatile memory as default.

10-39 Devicenet F Parameters

Array [1000]

No LCP access

Range:

0 N/A* [0 - 0 N/A]

Function:

This parameter is used to configure the adjustable frequency drive via DeviceNet and build the EDS file.

3.13 Parameters: Ethernet

3.13.1 IP Settings

12-00 IP Address Assignment

Option:	Function:
[0] * Manual	Selects the IP address assignment method. The IP address can be set in par. 12-01 IP Address.
[1] DHCP	The IP address is assigned via DHCP server.
[2] BOOTP	The IP address is assigned via BOOTP server.

3

12-01 IP Address

Range:	Function:
[000.000.000.000–255.255.255.255]	Configure the IP address of the option. Read-only if par. 12-00 set to DHCP or BOOTP.

12-02 Subnet Mask

Range:	Function:
[000.000.000.000–255.255.255.255]	Configure the IP subnet mask of the option. Read-only if par. 12-00 set to DHCP or BOOTP.

12-03 Default Gateway

Range:	Function:
[000.000.000.000–255.255.255.255]	Configure the IP default gateway of the option. Read-only if par. 12-00 set to DHCP or BOOTP.

12-04 DHCP Server

Range:	Function:
[000.000.000.000–255.255.255.255]	Read only. Displays the IP address of the found DHCP or BOOTP server.



NOTE!
A power cycle is necessary after setting the IP parameters manually.

12-05 Lease Expires

Range:	Function:
[dd:hh:mm:ss]	Read only. Displays the lease time left for the current DHCP-assigned IP address.

12-06 Name Servers

Option:	Function:
[0] Primary DNS	IP addresses of Domain Name Servers. Can be automatically assigned when using DHCP.
[1] Secondary DNS	

12-07 Domain Name

Range:	Function:
Blank [0–19 characters]	Domain name of the attached network. Can be automatically assigned when using DHCP.

12-08 Host Name

Range:

Blank [0–19 characters]

Function:

Logical (given) name of option.

12-09 Physical Address

Range:

[00:1B:08:00:00:00–00:1B:08:FF:FF:FF]

Function:

Read only: Displays the Physical (MAC) address of the option.

3.13.2 12-1* Eth link par

12-1* Ethernet Link Parameters

Option:
[0] Port 1
[1] Port 2
Function:

Applies for whole parameter group.

12-10 Link Status

Option:
[0] No link
[1] Link
Function:

Read only. Displays the link status of the Ethernet ports.

12-11 Link Duration

Option:

Link Duration Port 1 (dd:hh:mm:ss)

Function:

Read only. Displays the duration of the present link on each port in dd:hh:mm:ss.

12-12 Auto Negotiation

Option:
[0] Off
[1] On
Function:

Configures Auto Negotiation of Ethernet link parameters for each port, ON or OFF.

Link Speed and *Link Duplex* can be configured in par. 12-13 and 12-14.

12-13 Link Speed

Option:
[0] * None
[1] 10 Mbps
[2] 100 Mbps
Function:

Forces the link speed for each port at 10 or 100 Mbps. If par. 12-12 is set to ON, this parameter is read-only and displays the actual link speed. "None" is displayed if no link is present.

12-14 Link Duplex

Option:
[0] Half duplex
[1] * Full duplex
Function:

Forces the duplex for each port to full or half duplex. If par. 12-12 is set to ON, this parameter is read-only.

3.13.3 12-2* Process Data

12-20 Control Instance

Range:	Function:
[None, 20, 21, 100, 101, 103]	Read only. Displays the originator-to-target connection point. If no CIP connection is present, "None" is displayed.

12-21 Process Data Config Write

Range:	Function:
[[0-9] PCD read 0-9]	Configuration of readable process data.

NOTE!
For configuration of 2-word (32-bit) parameter read/write, use 2 consecutive arrays in par. 12-21 and 12-22.

12-22 Process Data Config Read

Range:	Function:
[[0-9] PCD read 0-9]	Configuration of readable process data.

12-28 Store Data Values

Option:	Function:
	This parameter activates a function that stores all parameter values in the non-volatile memory (EEPROM) thus retaining parameter values at power-down. The parameter returns to "Off".

[0] *	Off	The store function is inactive.
[1]	Store all set-ups	All parameter value will be stored in the non-volatile memory in all four set-ups.

12-29 Store Always

Option:	Function:
	Activates function that will always store received parameter data in non-volatile memory (EEPROM).

[0] *	Off
[1]	On

3.13.4 EtherNet/IP

12-30 Warning Parameter

Range:	Function:
[0000-FFFF hex]	Read only. Displays the EtherNet/IP specific 16-bit status word.

Bit	Description
0	Owned
1	Not used
2	Configured
3	Not used
4	Not used
5	Not used
6	Not used
7	Not used
8	Minor recoverable fault
9	Minor unrecoverable fault
10	Major recoverable fault
11	Major unrecoverable fault
12	Not used
13	Not used
14	Not used
15	Not used

12-31 Net Reference

Option:
Function:

Read only. Displays the reference source in Instance 21/71.

[0] * Off

Reference from the network is not active.

[1] On

Reference from the network is active.

12-32 Net Control

Option:
Function:

Read only. Displays the control source in Instance 21/71.

[0] * Off

Control via the network is not active.

[1] On

Control via the network is active

12-33 CIP Revision

Option:
Function:

Read only. Displays the CIP version of the option software.

[0] Major version (00–99)

[1] Minor version (00–99)

12-34 CIP Product Code

Range:

1100 (FC [0 – 9999]

302) 1110

(FC 301)*

Function:

Read only. Displays the CIP product code.

12-37 COS Inhibit Timer

Range:

[0–65.535 ms]

Function:

Read-only Change-Of-State inhibit timer. If the option is configured for COS operation, this inhibit timer can be configured in the Forward Open message to prevent that continuously changing PCD data generates extensive network traffic. The inhibit time is in milliseconds, 0 = disabled.

12-38 COS Filters

Range:

[[0-9] Filter 0-9 (0000-FFFFhex)]

Function:

Change-Of-State PCD filters. Sets up a filter mask for each word of process data when operating in COS mode. Single bits in the PCDs can be filtered in/out.

3.13.5 12-8* Oth. Eth. services

12-80 FTP Server

Option:

[0] * Disable

[1] Enable

Function:

Disables the built-in FTP server.

Enables the built-in FTP server.

12-81 HTTP Server

Option:

[0] * Disable

[1] Enable

Function:

Disables the built-in HTTP (web) server.

Enables the built-in HTTP (web) server.

12-82 SMTP Service

Option:

[0] * Disable

[1] Enable

Function:

Disables the SMTP (e-mail) service on the option.

Enables the SMTP (e-mail) service on the option.

12-89 Transparent Socket Channel Port

Range:

0* [0 - 9999]

Function:

Configures the TCP port number for the transparent socket channel. This enables adjustable frequency drive message to be sent transparently on Ethernet via TCP. Default value is 4000, 0 means disabled.

3.13.6 12-9* Adv. Eth. settings

12-90 Cable Diagnostics

Option:

[0] * Disable

[1] Enable

Function:

Enables/disables advanced cable diagnosis function. If enabled, the distance to cable errors can be read out in par. 12-93. The parameter resumes to the default setting of Disable after the diagnostics have finished.



NOTE!

The cable diagnostics function will only be issued on ports where there is no link (see par. 12-10, *Link Status*)

12-91 Auto Cross-Over

Option:

[0] Disable

[1] * Enable

Function:

Disables the auto cross-over function.

Enables the auto cross-over function.

**NOTE!**

Disabling of the auto cross-over function will require crossed Ethernet cables for daisy-chaining the options.

3

12-92 IGMP Snooping**Option:****Function:**

This prevents flooding of the Ethernet protocol stack by only forwarding multicast packets to ports that are a member of the multicast group

[0] Disable

Disables the IGMP snooping function.

[1] * Enable

Enables the IGMP snooping function.

12-93 Cable Error Length**Option:****Function:**

If Cable Diagnostics is enabled in par. 12-90, the built-in switch is enabled via Time Domain Reflectometry (TDR). This is a measurement technique which detects common cabling problems such as open circuits, short circuits and impedance mismatches or breaks in transmission cables. The distance from the option to the error is displayed in meters [feet] with an accuracy of +/- 2 m [6.5 ft]. The value 0 means no errors detected.

[0] Error length Port 1 (0–200 m [0–656 ft])

[1] Error length Port 2 (0–200 m [0–656 ft])

12-94 Broadcast Storm Protection**Option:****Function:**

The built-in switch is capable of protecting the switch system from receiving too many broadcast packages, which can use up network resources. The value indicates a percentage of the total bandwidth that is allowed for broadcast messages.

Example:

The "OFF" means that the filter is disabled, and all broadcast messages will be passed through. The value "0%" means that no broadcast messages will be passed through. A value of "10%" means that 10% of the total bandwidth is allowed for broadcast messages. If the amount of broadcast messages increases above the 10% threshold, they will be blocked.

[0] Protection Value Port 1 (*Off – 20%)

[1] Protection Value Port 2 (*Off – 20%)

12-95 Broadcast Storm Filter**Option:****Function:**

Applies to par. 12-94 if broadcast storm protection should also include Multicast messages.

[0] Broadcast only

[1] Broadcast & Multicast

12-98 Interface Counters

Option:

Function:

Read only. Advanced interface counters from the built-in switch can be used for low-level troubleshooting. The parameter shows the sum of port 1 + port 2.

[0] In Octets

[1] In Unicast Packets

[2] In Non-Unicast Packets

[3] In Discards

[4] In Errors

[5] In Unknown Protocols

[6] Out Octets

[7] Out Unicast Packets

[8] Out Non-Unicast Packets

[9] Out Discards

[10] Out Errors

12-99 Media Counters

Option:

Function:

Read only. Advanced interface counters from the built-in switch can be used for low-level troubleshooting. The parameter shows the sum of port 1 + port 2.

[0] Alignment Errors

[1] FCS Errors

[2] Single Collisions

[3] Multiple Collisions

[4] SQE Test Errors

[5] Deferred Errors

[6] Late Collisions

[7] Excessive Collisions

[8] MAC Transmit Errors

[9] Carrier Sense Errors

[10] Frame Too Long

[11] MAC Receive Errors

3.14 Parameters: Smart Logic Control

3.14.1 13-** Prog. Features

Smart Logic Control (SLC) is essentially a sequence of user defined actions (see par. 13-52 *SL Controller Action [x]*) executed by the SLC when the associated user defined *event* (see par. 13-51 *SL Controller Event [x]*) is evaluated as TRUE by the SLC. Events and *actions* are each numbered and linked together in pairs (states). This means that when *event [0]* is fulfilled (attains the value TRUE), *action [0]* is executed. After this, the conditions of *event [1]* will be evaluated and if evaluated TRUE, *action [1]* will be executed and so on. Only one *event* will be evaluated at any time. If an *event* is evaluated as FALSE, nothing happens (in the SLC) during the current scan interval and no other *events* will be evaluated. This means that when the SLC starts, it evaluates *event [0]* (and only *event [0]*) each scan interval. Only when *event [0]* is evaluated TRUE, will the SLC execute *action [0]* and start evaluating *event [1]*. It is possible to program from 1 to 20 *events* and *actions*.

When the last *event / action* has been executed, the sequence starts over again from *event [0] / action [0]*. The figure shows an example with three event / actions:

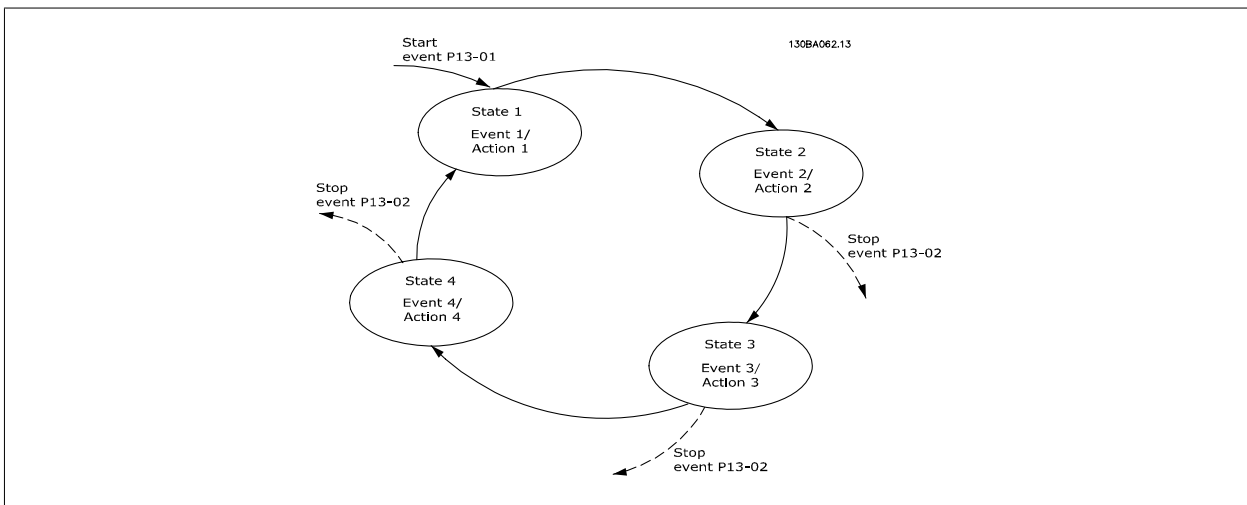

Starting and stopping the SLC:

Starting and stopping the SLC can be done by selecting .On [1], or .Off [0], in par. 13-00 *SL Controller Mode*. The SLC always starts in state 0 (where it evaluates *event [0]*). The SLC starts when the start event (defined in par. 13-01 *Start Event*) is evaluated as TRUE (provided that *On [1]* is selected in par. 13-00 *SL Controller Mode*). The SLC stops when the *Stop Event* (par. 13-02 *Stop Event*) is TRUE. par. 13-03 *Reset SLC* resets all SLC parameters and start programming from scratch.

3.14.2 13-0* SLC Settings

Use the SLC settings to activate, deactivate and reset the Smart Logic Control sequence. The logic functions and comparators are always running in the background, which opens for separate control of digital inputs and outputs. .

13-00 SL Controller Mode

Option:	Function:
[0] Off	Disables the Smart Logic Controller.
[1] On	Enables the Smart Logic Controller.

13-01 Start Event

Option:	Function:
[0] * FALSE	Select the Boolean (TRUE or FALSE) input to activate Smart Logic Control.

		<i>False</i> [0] enters the fixed value - FALSE
[1]	TRUE	<i>True</i> [1] enters the fixed value - TRUE.
[2]	Running	<i>Running</i> [2] The motor is running.
[3]	In range	<i>In range</i> [3] The motor is running within the programmed current and speed ranges set in par. 4-50 <i>Warning Current Low</i> to par. 4-53 <i>Warning Speed High</i> .
[4]	On reference	<i>On reference</i> [4] The motor is running on reference.
[5]	Torque limit	<i>Torque limit</i> [5] The torque limit, set in par. 4-16 <i>Torque Limit Motor Mode</i> or par. 4-17 <i>Torque Limit Generator Mode</i> , has been exceeded.
[6]	Current limit	<i>Current limit</i> [6] The motor current limit, set in par. 4-18 <i>Current Limit</i> , has been exceeded.
[7]	Out of current range	<i>Out of current range</i> [7] The motor current is outside the range set in par. 4-18 <i>Current Limit</i> .
[8]	Below I low	<i>Below I low</i> [8] The motor current is lower than set in par. 4-50 <i>Warning Current Low</i> .
[9]	Above I high	<i>Above I high</i> [9] The motor current is higher than set in par. 4-51 <i>Warning Current High</i> .
[10]	Out of speed range	<i>Out of speed range</i> [10] The speed is outside the range set in par. 4-52 <i>Warning Speed Low</i> and par. 4-53 <i>Warning Speed High</i> .
[11]	Below speed low	<i>Below speed low</i> [11] The output speed is lower than the setting in par. 4-52 <i>Warning Speed Low</i> .
[12]	Above speed high	<i>Above speed high</i> [12] The output speed is higher than the setting in par. 4-53 <i>Warning Speed High</i> .
[13]	Out of feedb. range	<i>Out of feedb. Range</i> [13] The feedback is outside the range set in par. 4-56 <i>Warning Feedback Low</i> and par. 4-57 <i>Warning Feedback High</i> .
[14]	Below feedb. low	<i>Below feedb. Low</i> [14] The feedback is below the limit set in par. 4-56 <i>Warning Feedback Low</i> .
[15]	Above feedb. high	<i>Above feedb. High</i> [15] The feedback is above the limit set in par. 4-57 <i>Warning Feedback High</i> .
[16]	Thermal warning	<i>Thermal warning</i> [16]:the thermal warning turns on when the temperature exceeds the limit in the motor, the adjustable frequency drive, the brake resistor or the thermistor.
[17]	Mains out of range	AC line voltage out of range [17] The AC line voltage is outside the specified voltage range.
[18]	Reverse	<i>Reversing</i> [18] The output is high when the adjustable frequency drive is running counter-clockwise (the logical product of the status bits "running" AND "reverse").
[19]	Warning	<i>Warning</i> [19] A warning is active.
[20]	Alarm (trip)	<i>Alarm (trip)</i> [20] A (trip) alarm is active.
[21]	Alarm (trip lock)	<i>Alarm (trip lock)</i> [21] A (Trip lock) alarm is active.
[22]	Comparator 0	<i>Comparator 0</i> [22] Use the result of comparator 0.
[23]	Comparator 1	<i>Comparator 1</i> [23] Use the result of comparator 1.
[24]	Comparator 2	<i>Comparator 2</i> [24] Use the result of comparator 2.
[25]	Comparator 3	<i>Comparator 3</i> [25] Use the result of comparator 3.
[26]	Logic rule 0	<i>Logic rule 0</i> [26] Use the result of logic rule 0.
[27]	Logic rule 1	<i>Logic rule 1</i> [27] Use the result of logic rule 1.
[28]	Logic rule 2	<i>Logic rule 2</i> [28] Use the result of logic rule 2.
[29]	Logic rule 3	<i>Logic rule 3</i> [29] Use the result of logic rule 3.
[33]	Digital input DI18	<i>Digital input DI18</i> [33] Use the result of digital input 18.

[34]	Digital input DI19	<i>Digital input DI19</i> [34] Use the result of digital input 19.
[35]	Digital input DI27	<i>Digital input DI27</i> [35] Use the result of digital input 27.
[36]	Digital input DI29	<i>Digital input DI27</i> [35] Use the result of digital input 29.
[37]	Digital input DI32	<i>Digital input DI32</i> [37] Use the result of digital input 32.
[38]	Digital input DI33	<i>Digital input DI33</i> [38] Use the result of digital input 33.
[39]	Start command	<i>Start command</i> [39] A start command is issued.
[40]	Drive stopped	<i>Drive stopped</i> [40] A stop command (Jog, Stop, Qstop, Coast) is issued – and not from the SLC itself.
[41]	Reset Trip	<i>Reset Trip</i> [41] A reset is issued
[42]	Auto-reset Trip	<i>Auto-reset Trip</i> [42]: an auto reset is performed.
[43]	OK key	<i>OK key</i> [43] The Ok key is pressed.
[44]	Reset key	<i>Reset key</i> [44] The reset key is pressed.
[45]	Left key	<i>Left key</i> [45] The left key is pressed.
[46]	Right key	<i>Right key</i> [46] The right key is pressed.
[47]	Up key	<i>Up key</i> [47] The up key is pressed.
[48]	Down key	<i>Down key</i> [48] The down key is pressed.
[50]	Comparator 4	<i>Comparator 4</i> [50] Use the result of comparator 4.
[51]	Comparator 5	<i>Comparator 5</i> [51] Use the result of comparator 5.
[60]	Logic rule 4	<i>Logic rule 4</i> [60] Use the result of logic rule 4.
[61]	Logic rule 5	<i>Logic rule 5</i> [61] Use the result of logic rule 5.

13-02 Stop Event

Select the Boolean (TRUE or FALSE) input to activate Smart Logic Control.

Option:

Function:

[0] *	FALSE	For descriptions [0] - [61], see par. 13-01 <i>Start Event Start Event</i>
[1]	TRUE	
[2]	Running	
[3]	In range	
[4]	On reference	
[5]	Torque limit	
[6]	Current limit	
[7]	Out of current range	
[8]	Below I low	
[9]	Above I high	
[10]	Out of speed range	
[11]	Below speed low	
[12]	Above speed high	
[13]	Out of feedb. range	
[14]	Below feedb. low	
[15]	Above feedb. high	

[16]	Thermal warning	
[17]	Mains out of range	
[18]	Reverse	
[19]	Warning	
[20]	Alarm (trip)	
[21]	Alarm (trip lock)	
[22]	Comparator 0	
[23]	Comparator 1	
[24]	Comparator 2	
[25]	Comparator 3	
[26]	Logic rule 0	
[27]	Logic rule 1	
[28]	Logic rule 2	
[29]	Logic rule 3	
[30]	SL Timeout 0	
[31]	SL Timeout 1	
[32]	SL Timeout 2	
[33]	Digital input DI18	
[34]	Digital input DI19	
[35]	Digital input DI27	
[36]	Digital input DI29	
[37]	Digital input DI32	
[38]	Digital input DI33	
[39]	Start command	
[40]	Drive stopped	
[41]	Reset Trip	
[42]	Auto-reset Trip	
[43]	OK key	
[44]	Reset key	
[45]	Left key	
[46]	Right key	
[47]	Up key	
[48]	Down key	
[50]	Comparator 4	
[51]	Comparator 5	
[60]	Logic rule 4	
[61]	Logic rule 5	
[70]	SL Timeout 3	<i>SL Timeout 3</i> [70] Smart logic controller timer 3 is timed out.
[71]	SL Timeout 4	<i>SL Timeout 4</i> [71] Smart logic controller timer 4 is timed out.
[72]	SL Timeout 5	<i>SL Timeout 5</i> [72] Smart logic controller timer 5 is timed out.
[73]	SL Timeout 6	<i>SL Timeout 6</i> [73] Smart logic controller timer 6 is timed out.
[74]	SL Timeout 7	<i>SL Timeout 7</i> [74] Smart logic controller timer 7 is timed out.

[75]	Start command given
------	---------------------

[76]	Digital input x30 2
------	---------------------

[77]	Digital input x30 3
------	---------------------

[78]	Digital input x30 4
------	---------------------

13-03 Reset SLC

Option:
Function:

[0] *	Do not reset SLC
-------	------------------

Retains programmed settings in all group 13 parameters (13-*).
--

[1]	Reset SLC
-----	-----------

Resets all group 13 parameters (13-*) to default settings.
--

3.14.3 13-1* Comparators

Comparators are used for comparing continuous variables (i.e., output frequency, output current, analog input, etc.) to fixed preset values. In addition, there are digital values that will be compared to fixed time values. See explanation in par. 13-10 *Comparator Operand*. Comparators are evaluated once in each scan interval. Use the result (TRUE or FALSE) directly. All parameters in this parameter group are array parameters with an index of 0 to 5. Select index 0 to program Comparator 0, select index 1 to program Comparator 1, etc.

13-10 Comparator Operand

Array [6]

Option:
Function:

Choices [1] to [31] are variables that will be compared based on their values. Choices [50] to [186] are digital values (TRUE/FALSE) where the comparison is based on the amount of time during which they are set to TRUE or FALSE, respectively. See par. 13-11 *Comparator Operator*.
Select the variable to be monitored by the comparator.

[0] *	DISABLED
-------	----------

<i>DISABLED</i> [0] The comparator is disabled.

[1]	Reference
-----	-----------

<i>Reference</i> [1] The resulting remote reference (not local) as a percentage.
--

[2]	Feedback
-----	----------

<i>Feedback</i> [2] In the unit [RPM] or [Hz]

[3]	Motor speed
-----	-------------

<i>Motor speed</i> [3] [RPM] or [Hz]

[4]	Motor current
-----	---------------

<i>Motor current</i> [4] [A]

[5]	Motor torque
-----	--------------

<i>Motor torque</i> [5] [Nm]

[6]	Motor power
-----	-------------

<i>Motor power</i> [6] [kW] or [hp]

[7]	Motor voltage
-----	---------------

<i>Motor voltage</i> [7] [V]

[8]	DC-link voltage
-----	-----------------

<i>DC link voltage</i> [8] [V]

[9]	Motor thermal
-----	---------------

<i>Motor thermal</i> [9] Expressed as a percentage.

[10]	VLT temp.
------	-----------

<i>VLT thermal</i> [10] Expressed as a percentage.
--

[11]	Heat sink temp.
------	-----------------

<i>Heatsink temp</i> [11] Expressed as a percentage.
--

[12]	Analog input AI53
------	-------------------

<i>Analog input AI53</i> [12] Expressed as a percentage.
--

[13]	Analog input AI54
------	-------------------

<i>Analog input AI54</i> [13] Expressed as a percentage.
--

[14]	Analog input AIFB10
------	---------------------

<i>Analog input AIFB10</i> [14] [V]. AIFB10 is internal 10 V supply.
--

[15]	Analog input AIS24V
------	---------------------

<i>Analog input AIS24V</i> [15] [V] Analog input AICCT [17] [°]. AIS24V is switch mode power supply: SMPS 24 V.

[17]	Analog input AICCT	Analog input AICCT [17] [°]. AICCT is control card temperature.
[18]	Pulse input FI29	<i>Pulse input FI29</i> [18] Expressed as a percentage.
[19]	Pulse input FI33	<i>Pulse input FI33</i> [19] Expressed as a percentage.
[20]	Alarm number	<i>Alarm number</i> [20] The error number.
[21]	Warning number	
[22]	Analog input x30 11	
[23]	Analog input x30 12	
[30]	Counter A	<i>Counter A</i> [30] Number of counts
[31]	Counter B	<i>Counter B</i> [31] Number of counts
[50]	FALSE	<i>False</i> [50] Enters the fixed value of false in the comparator.
[51]	TRUE	<i>True</i> [51] Enters the fixed value of true in the comparator.
[52]	Control ready	<i>Control ready</i> [52] The control board receives supply voltage
[53]	Drive ready	<i>Drive ready</i> [53] The adjustable frequency drive is ready for operation and applies a supply signal on the control board.
[54]	Running	<i>Running</i> [54] The motor is running.
[55]	Reversing	<i>Reversing</i> [55] The output is high when the adjustable frequency drive is running counter-clockwise (the logical product of the status bits "running" AND "reverse")
[56]	In range	<i>In range</i> [56] The motor is running within the programmed current and speed ranges set in par. 4-50 <i>Warning Current Low</i> to par. 4-53 <i>Warning Speed High</i> .
[60]	On reference	<i>On reference</i> [60] The motor is running on reference.
[61]	Below Reference Low	<i>Below reference, low</i> [61] The motor is running below the value given in par. 4-54 <i>Warning Reference Low</i>
[62]	Above ref, high	<i>Above reference, high</i> [62] The motor is running above the value given in par. 4-55 <i>Warning Reference High</i>
[65]	Torque limit	<i>Torque limit</i> [65] The torque limit, set in par. 4-16 <i>Torque Limit Motor Mode</i> or par. 4-17 <i>Torque Limit Generator Mode</i> , has been exceeded.
[66]	Current limit	<i>Current limit</i> [66] The motor current limit, set in par. 4-18 <i>Current Limit</i> , has been exceeded.
[67]	Out of current range	<i>Out of current range</i> [67] The motor current is outside the range set in par. 4-18 <i>Current Limit</i> .
[68]	Below I low	<i>Below I low</i> [68] The motor current is lower than set in par. 4-50 <i>Warning Current Low</i> .
[69]	Above I high	<i>Above I high</i> [69] The motor current is higher than set in par. 4-51 <i>Warning Current High</i> .
[70]	Out of speed range	<i>Out of speed range</i> [70] The speed is outside the range set in par. 4-52 <i>Warning Speed Low</i> and par. 4-53 <i>Warning Speed High</i> .
[71]	Below speed low	<i>Below speed low</i> [71] The output speed is lower than the setting in par. 4-52 <i>Warning Speed Low</i> .
[72]	Above speed high	<i>Above speed high</i> [72] The output speed is higher than the setting in par. 4-53 <i>Warning Speed High</i> .
[75]	Out of feedb. range	<i>Out of feedb. Range</i> [75] The feedback is outside the range set in par. 4-56 <i>Warning Feedback Low</i> and par. 4-57 <i>Warning Feedback High</i> .
[76]	Below feedb. low	<i>Below feedb. Low</i> [76] The feedback is below the limit set in par. par. 4-56 <i>Warning Feedback Low</i> .

[77]	Above feedb. high	<i>Above feedb. High</i> [77] The feedback is above the limit set in par. 4-57 <i>Warning Feedback High</i> .
[80]	Thermal warning	<i>Thermal warning</i> [80] The thermal warning turns on when the temperature exceeds the limit in the motor, the adjustable frequency drive, the brake resistor or thermistor.
[82]	Line pwr out of range	<i>AC line voltage out of range</i> [82] The AC line voltage is outside the specified voltage range.
[85]	Warning	<i>Warning</i> [85] A warning is active.
[86]	ALARM (Trip)	<i>Alarm (trip)</i> [86] A (trip) alarm is active.
[87]	ALARM (Trip Lock)	<i>Alarm (trip lock)</i> [87] A (Trip lock) alarm is active.
[90]	Bus OK	<i>Bus OK</i> [90] Active communication (no timeout) via the serial communication port.
[91]	Torque limit & stop	<i>Torque limit & stop</i> [91] If the adjustable frequency drive has received a stop signal and is at the torque limit, the signal is logic "0."
[92]	Brake fault (IGBT)	<i>Brake fault (IGBT)</i> [92] The brake IGBT is short circuited.
[93]	Mech. brake control	<i>Mech. brake control</i> [93] The mechanical brake is active.
[94]	Safe stop active	
[100]	Comparator 0	<i>Comparator 0</i> [100] The result of comparator 0.
[101]	Comparator 1	<i>Comparator 1</i> [101] The result of comparator 1.
[102]	Comparator 2	<i>Comparator 2</i> [102] The result of comparator 2.
[103]	Comparator 3	<i>Comparator 3</i> [103] The result of comparator 3.
[104]	Comparator 4	<i>Comparator 4</i> [104] The result of comparator 4.
[105]	Comparator 5	<i>Comparator 5</i> [105] The result of comparator 5.
[110]	Logic rule 0	<i>Logic rule 0</i> [110] The result of logic rule 0.
[111]	Logic rule 1	<i>Logic rule 1</i> [111] The result of logic rule 1.
[112]	Logic rule 2	<i>Logic rule 2</i> [112] The result of logic rule 2.
[113]	Logic rule 3	<i>Logic rule 3</i> [113] The result of logic rule 3.
[114]	Logic rule 4	<i>Logic rule 4</i> [114] The result of logic rule 4.
[115]	Logic rule 5	<i>Logic rule 5</i> [115] The result of logic rule 5.
[120]	SL Timeout 0	<i>SL Timeout 0</i> [120] The result of SLC timer 0.
[121]	SL Timeout 1	<i>SL Timeout 1</i> [121] The result of SLC timer 1.
[122]	SL Timeout 2	<i>SL Timeout 2</i> [122] The result of SLC timer 2.
[123]	SL Timeout 3	<i>SL Timeout 3</i> [123] The result of SLC timer 3.
[124]	SL Timeout 4	<i>SL Timeout 4</i> [124] The result of SLC timer 4.
[125]	SL Timeout 5	<i>SL Timeout 5</i> [125] The result of SLC timer 5.
[126]	SL Timeout 6	<i>SL Timeout 6</i> [126] The result of SLC timer 6.
[127]	SL Timeout 7	<i>SL Timeout 7</i> [127] The result of SLC timer 7.
[130]	Digital input DI18	<i>Digital input DI18</i> [130] Digital input 18. High = True.
[131]	Digital input DI19	<i>Digital input DI19</i> [131] Digital input 19. High = True.
[132]	Digital input DI27	<i>Digital input DI27</i> [132] Digital input 27. High = True.

[133]	Digital input DI29	<i>Digital input DI29</i> [133] Digital input 29. High = True.
[134]	Digital input DI32	<i>Digital input DI32</i> [134] Digital input 32. High = True.
[135]	Digital input DI33	<i>Digital input DI33</i> [135] Digital input 33. High = True.
[150]	SL digital output A	<i>SL digital output A</i> [150] Use the result of the SLC output A.
[151]	SL digital output B	<i>SL digital output B</i> [151] Use the result of the SLC output B.
[152]	SL digital output C	<i>SL digital output C</i> [152] Use the result of the SLC output C.
[153]	SL digital output D	<i>SL digital output D</i> [153] Use the result of the SLC output D.
[154]	SL digital output E	<i>SL digital output E</i> [154] Use the result of the SLC output E.
[155]	SL digital output F	<i>SL digital output F</i> [155] Use the result of the SLC output F.
[160]	Relay 1	<i>Relay 1</i> [160] Relay 1 is active
[161]	Relay 2	<i>Relay 2</i> [161] Relay 2 is active
[180]	Local ref. active	<i>Local ref. active</i> [180] High when par. 3-13 <i>Reference Site</i> = [2] Local or when par. 3-13 <i>Reference Site</i> is [0] Linked to hand auto, at the same time as the LCP is in hand on mode.
[181]	Remote ref. active	<i>Remote ref. active</i> [181] High when par. 3-13 <i>Reference Site</i> = [1] Remote or [0] Linked to hand/ auto, while the LCP is in auto on mode.
[182]	Start command	<i>Start command</i> [182] High when there is an active start command and no stop command.
[183]	Drive stopped	<i>Drive stopped</i> [183] A stop command (Jog, Stop, Qstop, Coast) is issued – and not from the SLC itself.
[185]	Drive in hand mode	<i>Drive in hand mode</i> [185] High when the adjustable frequency drive is in hand mode.
[186]	Drive in auto mode	<i>Drive in auto mode</i> [186] High when the adjustable frequency drive is in auto mode.
[187]	Start command given	
[190]	Digital input x30 2	
[191]	Digital input x30 3	
[192]	Digital input x30 4	

13-11 Comparator Operator

Array [6]

Option:

Function:

		Select the operator to be used in the comparison. This is an array parameter containing comparator operators 0 to 5.
[0]	<	Select < [0] for the result of the evaluation to be TRUE, when the variable selected in par. 13-10 <i>Comparator Operand</i> is smaller than the fixed value in par. 13-12 <i>Comparator Value</i> . The result will be FALSE, if the variable selected in par. 13-10 <i>Comparator Operand</i> is greater than the fixed value in par. 13-12 <i>Comparator Value</i> .
[1] *	= (equal)	Select ≈ [1] for the result of the evaluation to be TRUE, when the variable selected in par. 13-10 <i>Comparator Operand</i> is approximately equal to the fixed value in par. 13-12 <i>Comparator Value</i> .
[2]	>	Select > [2] for the inverse logic of option < [0].
[5]	TRUE longer than..	
[6]	FALSE longer than..	
[7]	TRUE shorter than..	

[8] FALSE shorter than..

13-12 Comparator Value

Array [6]

Range:

Application [-100000.000 - 100000.000 N/A]
dependent*

Function:

Enter the 'trigger level' for the variable that is monitored by this comparator. This is an array parameter containing comparator values 0 to 5.

3

3.14.4 13-2* Timers

This parameter group consists of timer parameters.

Use the result (TRUE or FALSE) from *timers* directly to define an *event* (see par. 13-51 *SL Controller Event*), or as Boolean input in a *logic rule* (see par. 13-40 *Logic Rule Boolean 1*, par. 13-42 *Logic Rule Boolean 2* or par. 13-44 *Logic Rule Boolean 3*). A timer is only FALSE when started by an action (i.e., Start timer 1 [29]) until the timer value entered in this parameter is elapsed. Then it becomes TRUE again.

All parameters in this parameter group are array parameters with an index of 0 to 2. Select index 0 to program Timer 0, select index 1 to program Timer 1, and so on.

13-20 SL Controller Timer

Range:

Application [Application dependant]
dependent*

Function:

3.14.5 13-4* Logic Rules

Combine up to three boolean inputs (TRUE / FALSE inputs) from timers, comparators, digital inputs, status bits and events using the logical operators AND, OR, and NOT. Select Boolean inputs for the calculation in par. 13-40 *Logic Rule Boolean 1*, par. 13-42 *Logic Rule Boolean 2* and par. 13-44 *Logic Rule Boolean 3*. Define the operators used to logically combine the selected inputs in par. 13-41 *Logic Rule Operator 1* and par. 13-43 *Logic Rule Operator 2*.

Priority of calculation

The results of par. 13-40 *Logic Rule Boolean 1*, par. 13-41 *Logic Rule Operator 1* and par. 13-42 *Logic Rule Boolean 2* are calculated first. The outcome (TRUE / FALSE) of this calculation is combined with the settings of par. 13-43 *Logic Rule Operator 2* and par. 13-44 *Logic Rule Boolean 3*, yielding the final result (TRUE / FALSE) of the logic rule.

13-40 Logic Rule Boolean 1

Array [6]

Option:

[0] * FALSE

Function:

Select the first Boolean (TRUE or FALSE) input for the selected logic rule.
See par. 13-01 *Start Event* ([0] - [61]) and par. 13-02 *Stop Event* ([70] - [75]) for further description.

[1] TRUE

[2] Running

[3] In range

[4] On reference

[5] Torque limit

[6] Current limit

[7] Out of current range

[8] Below I low

[9] Above I high

[10]	Out of speed range
[11]	Below speed low
[12]	Above speed high
[13]	Out of feedb. range
[14]	Below feedb. low
[15]	Above feedb. high
[16]	Thermal warning
[17]	Mains out of range
[18]	Reverse
[19]	Warning
[20]	Alarm (trip)
[21]	Alarm (trip lock)
[22]	Comparator 0
[23]	Comparator 1
[24]	Comparator 2
[25]	Comparator 3
[26]	Logic rule 0
[27]	Logic rule 1
[28]	Logic rule 2
[29]	Logic rule 3
[30]	SL Timeout 0
[31]	SL Timeout 1
[32]	SL Timeout 2
[33]	Digital input DI18
[34]	Digital input DI19
[35]	Digital input DI27
[36]	Digital input DI29
[37]	Digital input DI32
[38]	Digital input DI33
[39]	Start command
[40]	Drive stopped
[41]	Reset Trip
[42]	Auto-reset Trip
[43]	OK key
[44]	Reset key
[45]	Left key
[46]	Right key
[47]	Up key
[48]	Down key
[50]	Comparator 4
[51]	Comparator 5
[60]	Logic rule 4
[61]	Logic rule 5

[70]	SL Timeout 3
[71]	SL Timeout 4
[72]	SL Timeout 5
[73]	SL Timeout 6
[74]	SL Timeout 7
[75]	Start command given
[76]	Digital input x30 2
[77]	Digital input x30 3
[78]	Digital input x30 4

13-41 Logic Rule Operator 1

Array [6]

Option:

Function:

Select the first logical operator to use on the Boolean inputs from par. 13-40 *Logic Rule Boolean 1* and par. 13-42 *Logic Rule Boolean 2*.

[13 -XX] signifies the Boolean input of par. group 13-*

[0] *	DISABLED	Ignores par. 13-42 <i>Logic Rule Boolean 2</i> , par. 13-43 <i>Logic Rule Operator 2</i> , and par. 13-44 <i>Logic Rule Boolean 3</i> .
[1]	AND	Evaluates the expression [13-40] AND [13-42].
[2]	OR	evaluates the expression [13-40] OR [13-42].
[3]	AND NOT	evaluates the expression [13-40] AND NOT [13-42].
[4]	OR NOT	evaluates the expression [13-40] OR NOT [13-42].
[5]	NOT AND	evaluates the expression NOT [13-40] AND [13-42].
[6]	NOT OR	evaluates the expression NOT [13-40] OR [13-42].
[7]	NOT AND NOT	evaluates the expression NOT [13-40] AND NOT [13-42].
[8]	NOT OR NOT	evaluates the expression NOT [13-40] OR NOT [13-42].

13-42 Logic Rule Boolean 2

Array [6]

Option:

Function:

Select the second Boolean (TRUE or FALSE) input for the selected logic rule. See par. 13-01 *Start Event* ([0] - [61]) and par. 13-02 *Stop Event* ([70] - [75]) for further description.

[1]	TRUE
[2]	Running
[3]	In range
[4]	On reference
[5]	Torque limit
[6]	Current limit
[7]	Out of current range
[8]	Below I low
[9]	Above I high
[10]	Out of speed range
[11]	Below speed low

[12]	Above speed high
[13]	Out of feedb. range
[14]	Below feedb. low
[15]	Above feedb. high
[16]	Thermal warning
[17]	Mains out of range
[18]	Reverse
[19]	Warning
[20]	Alarm (trip)
[21]	Alarm (trip lock)
[22]	Comparator 0
[23]	Comparator 1
[24]	Comparator 2
[25]	Comparator 3
[26]	Logic rule 0
[27]	Logic rule 1
[28]	Logic rule 2
[29]	Logic rule 3
[30]	SL Timeout 0
[31]	SL Timeout 1
[32]	SL Timeout 2
[33]	Digital input DI18
[34]	Digital input DI19
[35]	Digital input DI27
[36]	Digital input DI29
[37]	Digital input DI32
[38]	Digital input DI33
[39]	Start command
[40]	Drive stopped
[41]	Reset Trip
[42]	Auto-reset Trip
[43]	OK key
[44]	Reset key
[45]	Left key
[46]	Right key
[47]	Up key
[48]	Down key
[50]	Comparator 4
[51]	Comparator 5
[60]	Logic rule 4
[61]	Logic rule 5
[70]	SL Timeout 3
[71]	SL Timeout 4

[72]	SL Timeout 5
[73]	SL Timeout 6
[74]	SL Timeout 7
[75]	Start command given
[76]	Digital input x30 2
[77]	Digital input x30 3
[78]	Digital input x30 4

13-43 Logic Rule Operator 2

Array [6]

Option:

Function:

Select the second logical operator to be used on the Boolean input calculated in par. 13-40 *Logic Rule Boolean 1*, par. 13-41 *Logic Rule Operator 1*, and par. 13-42 *Logic Rule Boolean 2*, and the Boolean input coming from par. 13-42 *Logic Rule Boolean 2*.

[13-44] signifies the Boolean input of par. 13-44 *Logic Rule Boolean 3*.

[13-40/13-42] signifies the Boolean input calculated in par. 13-40 *Logic Rule Boolean 1*, par. 13-41 *Logic Rule Operator 1*, and par. 13-42 *Logic Rule Boolean 2*. DISABLED [0] (factory setting). select this option to ignore par. 13-44 *Logic Rule Boolean 3*.

[0] *	DISABLED
[1]	AND
[2]	OR
[3]	AND NOT
[4]	OR NOT
[5]	NOT AND
[6]	NOT OR
[7]	NOT AND NOT
[8]	NOT OR NOT

13-44 Logic Rule Boolean 3

Array [6]

Option:

Function:

[0] *	FALSE
-------	-------

Select the third Boolean (TRUE or FALSE) input for the selected logic rule. See par. 13-01 ([0] - [61]) and par. 13-02 ([70] - [75]) for further description.

[1]	TRUE
[2]	Running
[3]	In range
[4]	On reference
[5]	Torque limit
[6]	Current limit
[7]	Out of current range
[8]	Below I low
[9]	Above I high
[10]	Out of speed range
[11]	Below speed low
[12]	Above speed high
[13]	Out of feedb. range

[14]	Below feedb. low
[15]	Above feedb. high
[16]	Thermal warning
[17]	Mains out of range
[18]	Reverse
[19]	Warning
[20]	Alarm (trip)
[21]	Alarm (trip lock)
[22]	Comparator 0
[23]	Comparator 1
[24]	Comparator 2
[25]	Comparator 3
[26]	Logic rule 0
[27]	Logic rule 1
[28]	Logic rule 2
[29]	Logic rule 3
[30]	SL Timeout 0
[31]	SL Timeout 1
[32]	SL Timeout 2
[33]	Digital input DI18
[34]	Digital input DI19
[35]	Digital input DI27
[36]	Digital input DI29
[37]	Digital input DI32
[38]	Digital input DI33
[39]	Start command
[40]	Drive stopped
[41]	Reset Trip
[42]	Auto-reset Trip
[43]	OK key
[44]	Reset key
[45]	Left key
[46]	Right key
[47]	Up key
[48]	Down key
[50]	Comparator 4
[51]	Comparator 5
[60]	Logic rule 4
[61]	Logic rule 5
[70]	SL Timeout 3
[71]	SL Timeout 4
[72]	SL Timeout 5
[73]	SL Timeout 6

[74]	SL Timeout 7
[75]	Start command given
[76]	Digital input x30 2
[77]	Digital input x30 3
[78]	Digital input x30 4

3

3.14.6 13-5* States

Parameters for programming the Smart Logic Controller.

13-51 SL Controller Event

Array [20]

Option:

Function:

[0] *	FALSE	Select the Boolean input (TRUE or FALSE) to define the Smart Logic Controller event. See par. 13-01 <i>Start Event</i> ([0] - [61]) and par. 13-02 <i>Stop Event</i> ([70] - [74]) for further description.
[1]	TRUE	
[2]	Running	
[3]	In range	
[4]	On reference	
[5]	Torque limit	
[6]	Current limit	
[7]	Out of current range	
[8]	Below I low	
[9]	Above I high	
[10]	Out of speed range	
[11]	Below speed low	
[12]	Above speed high	
[13]	Out of feedb. range	
[14]	Below feedb. low	
[15]	Above feedb. high	
[16]	Thermal warning	
[17]	Mains out of range	
[18]	Reverse	
[19]	Warning	
[20]	Alarm (trip)	
[21]	Alarm (trip lock)	
[22]	Comparator 0	
[23]	Comparator 1	
[24]	Comparator 2	
[25]	Comparator 3	
[26]	Logic rule 0	
[27]	Logic rule 1	
[28]	Logic rule 2	
[29]	Logic rule 3	

[30]	SL Timeout 0
[31]	SL Timeout 1
[32]	SL Timeout 2
[33]	Digital input DI18
[34]	Digital input DI19
[35]	Digital input DI27
[36]	Digital input DI29
[37]	Digital input DI32
[38]	Digital input DI33
[39]	Start command
[40]	Drive stopped
[41]	Reset Trip
[42]	Auto-reset Trip
[43]	OK key
[44]	Reset key
[45]	Left key
[46]	Right key
[47]	Up key
[48]	Down key
[50]	Comparator 4
[51]	Comparator 5
[60]	Logic rule 4
[61]	Logic rule 5
[70]	SL Timeout 3
[71]	SL Timeout 4
[72]	SL Timeout 5
[73]	SL Timeout 6
[74]	SL Timeout 7
[75]	Start command given
[76]	Digital input x30 2
[77]	Digital input x30 3
[78]	Digital input x30 4

13-52 SL Controller Action

Array [20]

Option:

Function:

[0] *	DISABLED	Select the action corresponding to the SLC event. Actions are executed when the corresponding event (defined in par. 13-51 <i>SL Controller Event</i>) is evaluated as true. The following actions are available for selection: <i>*DISABLED</i> [0]
[1]	No action	<i>No action</i> [1]
[2]	Select set-up 1	<i>Select set-up 1</i> [2] - changes the active set-up (par. 0-10) to '1'.
[3]	Select set-up 2	<i>Select set-up 2</i> [3] - changes the active set-up (par. 0-10) to '2'.

[4]	Select set-up 3	<i>Select set-up 3</i> [4] - changes the active set-up (par. 0-10) to '3'.
[5]	Select set-up 4	<i>Select set-up 4</i> [5] - changes the active set-up (par. 0-10) to '4'. If the set-up is changed, it will merge with other set-up commands coming from either the digital inputs or via a serial communication bus.
[10]	Select preset ref 0	<i>Select preset reference 0</i> [10] – selects preset reference 0.
[11]	Select preset ref 1	<i>Select preset reference 1</i> [11] – selects preset reference 1.
[12]	Select preset ref 2	<i>Select preset reference 2</i> [12] – selects preset reference 2.
[13]	Select preset ref 3	<i>Select preset reference 3</i> [13] – selects preset reference 3.
[14]	Select preset ref 4	<i>Select preset reference 4</i> [14] – selects preset reference 4.
[15]	Select preset ref 5	<i>Select preset reference 5</i> [15] – selects preset reference 5.
[16]	Select preset ref 6	<i>Select preset reference 6</i> [16] – selects preset reference 6.
[17]	Select preset ref 7	<i>Select preset reference 7</i> [17] - selects preset reference 7. If the active preset reference is changed, it will merge with other preset reference commands coming from either the digital inputs or via a serial communication bus.
[18]	Select ramp 1	<i>Select ramp 1</i> [18] - selects ramp 1.
[19]	Select ramp 2	<i>Select ramp 2</i> [19] - selects ramp 2.
[20]	Select ramp 3	<i>Select ramp 3</i> [20] - selects ramp 3.
[21]	Select ramp 4	<i>Select ramp 4</i> [21] - selects ramp 4.
[22]	Run	<i>Run</i> [22] - issues a start command to the adjustable frequency drive.
[23]	Run reverse	<i>Run reverse</i> [23] - issues a start reverse command to the adjustable frequency drive.
[24]	Stop	<i>Stop</i> [24] - issues a stop command to the adjustable frequency drive.
[25]	Q stop	<i>Qstop</i> [25] - issues a quick stop command to the adjustable frequency drive.
[26]	Dcstop	<i>Dcstop</i> [26] - issues a DC stop command to the adjustable frequency drive.
[27]	Coast	<i>Coast</i> [27] - the adjustable frequency drive coasts immediately. All stop commands including the coast command stop the SLC.
[28]	Freeze output	<i>Freeze output</i> [28] - freezes the output frequency of the adjustable frequency drive.
[29]	Start timer 0	<i>Start timer 0</i> [29] - starts timer 0, see par. 13-20 for further description.
[30]	Start timer 1	<i>Start timer 1</i> [30] - starts timer 1, see par. 13-20 for further description.
[31]	Start timer 2	<i>Start timer 2</i> [31] - starts timer 2, see par. 13-20 for further description.
[32]	Set digital out A low	<i>Set digital output A low</i> [32] - any output with SL output A will be low.
[33]	Set digital out B low	<i>Set digital output B low</i> [33] - any output with SL output B will be low.
[34]	Set digital out C low	<i>Set digital output C low</i> [34] - any output with SL output C will be low.
[35]	Set digital out D low	<i>Set digital output D low</i> [35] - any output with SL output D will be low.
[36]	Set digital out E low	<i>Set digital output E low</i> [36] - any output with SL output E will be low.
[37]	Set digital out F low	<i>Set digital output F low</i> [37] - any output with SL output F will be low.
[38]	Set digital out A high	<i>Set digital output A high</i> [38] - any output with SL output A will be high.
[39]	Set digital out B high	<i>Set digital output B high</i> [39] - any output with SL output B will be high.

[40]	Set digital out C high	<i>Set digital output C high</i> [40] - any output with SL output C will be high.
[41]	Set digital out D high	<i>Set digital output D high</i> [41] - any output with SL output D will be high.
[42]	Set digital out E high	<i>Set digital output E high</i> [42] - any output with SL output E will be high.
[43]	Set digital out F high	<i>Set digital output F high</i> [43] - any output with SL output F will be high.
[60]	Reset Counter A	<i>Reset Counter A</i> [60] - resets Counter A to zero.
[61]	Reset Counter B	<i>Reset Counter B</i> [61] - resets Counter B to zero.
[70]	Start timer 3	<i>Start Timer 3</i> [70] - Start Timer 3, see par. 13-20 for further description.
[71]	Start timer 4	<i>Start Timer 4</i> [71] - Start Timer 4, see par. 13-20 for further description.
[72]	Start timer 5	<i>Start Timer 5</i> [72] - Start Timer 5, see par. 13-20 for further description.
[73]	Start timer 6	<i>Start Timer 6</i> [73] - Start Timer 6, see par. 13-20 for further description.
[74]	Start timer 7	<i>Start Timer 7</i> [74] - Start Timer 7, see par. 13-20 for further description.

3.15 Parameters: Special Functions

3.15.1 14-** Special Functions

Parameter group for configuring special adjustable frequency drive functions.

3.15.2 14-0* Inverter Switching

Parameters for configuring the inverter switching.

14-00 Switching Pattern

Option:

Function:

[0] * 60 AVM

Select the switching pattern: 60° AVM or SFAVM.

[1] * SFAVM



NOTE!

The output frequency value of the adjustable frequency drive must never exceed 1/10 of the switching frequency. When the motor is running, adjust the switching frequency in par. 4-11 *Motor Speed Low Limit [RPM]* until the motor is as noiseless as possible. See also par. 14-00 *Switching Pattern* and the section *Special conditions* in the FC 300 Design Guide.



NOTE!

Switching frequencies higher than 5.0 kHz lead to automatic derating of the maximum output of the adjustable frequency drive.

14-01 Switching Frequency

Select the inverter switching frequency. Changing the switching frequency can help to reduce acoustic noise from the motor. Default depend on power size.

Option:

Function:

[0] 1.0 kHz

[1] 1.5 kHz

Default switching frequency for 500–1600 hp [355–1200 kW], 690 V

[2]	2.0 kHz	Default switching frequency for 350–1075 [250–800 kW], 400 V and 50–450 hp [37–315 kW], 690 V
[3]	2.5 kHz	
[4]	3.0 kHz	Default switching frequency for 25–50 hp [18.5–37 kW], 200 V and 50–150 hp [37–200 kW], 400 V
[5]	3.5 kHz	
[6]	4.0 kHz	Default switching frequency for 7.5–20 hp [5.5–15 kW], 200 V and 15–40 hp [11–30 kW], 400 V
[7] *	5.0 kHz	Default switching frequency for 0.34–5 hp [0.25–3.7 kW], 200 V and 0.5–10 hp [0.37–7.5 kW], 400 V
[8]	6.0 kHz	
[9]	7.0 kHz	
[10]	8.0 kHz	
[11]	10.0 kHz	
[12]	12.0 kHz	
[13]	14.0 kHz	
[14]	16.0 kHz	

**NOTE!**

The output frequency value of the adjustable frequency drive must never exceed 1/10 of the switching frequency. When the motor is running, adjust the switching frequency in par. 4-11 *Motor Speed Low Limit [RPM]* until the motor is as noiseless as possible. See also par. 14-00 *Switching Pattern* and the section *Special conditions* in the VLT AutomationDrive FC 300 Design Guide.

**NOTE!**

Switching frequencies higher than 5.0 kHz lead to automatic derating of the maximum output of the adjustable frequency drive.

14-03 Overmodulation

Option:**Function:**

[0]	Off	Select <i>On</i> [1] to connect the overmodulation function for the output voltage, and in order to obtain an output voltage of up to 15% higher than the AC line voltage. Select <i>Off</i> [0] for no overmodulation of the output voltage, in order to avoid torque ripple on the motor shaft. This feature may be useful for applications such as grinding machines.
-----	-----	---

[1] * On

14-04 PWM Random

Option:**Function:**

[0] *	Off	No change of the acoustic motor switching noise.
[1]	On	Transforms the acoustic motor switching noise from a clear ringing tone to a less noticeable 'white' noise. This is achieved by slightly and randomly altering the synchronism of the pulse width modulated output phases.

3.15.3 14-1* Line Supply On/Off

Parameters for configuring line failure monitoring and handling. If a line failure appears, the adjustable frequency drive will try to continue in a controlled manner until the power in the DC link has been exhausted.

14-10 Line Failure

Option:

Function:

Function: Select the function to which the adjustable frequency drive must act when the threshold in par. 14-11 *Mains Voltage at Mains Fault* has been reached.
 Par. 14-10 *Line Failure* cannot be changed while motor is running.

Controlled ramp-down:

The adjustable frequency drive will perform a controlled ramp-down. If par. 2-10 *Brake Function* is *Off*[0] or *AC brake* [2], the ramp will follow the Overvoltage Ramping. If par. 2-10 *Brake Function* is [1] *Resistor Brake* the ramp will follow the setting in par. 3-81 *Quick Stop Ramp Time*.

Controlled ramp-down [1]:

After power-up, the adjustable frequency drive is ready for start. Controlled ramp-down and trip [2]: After power-up, the adjustable frequency drive needs a reset for starting.

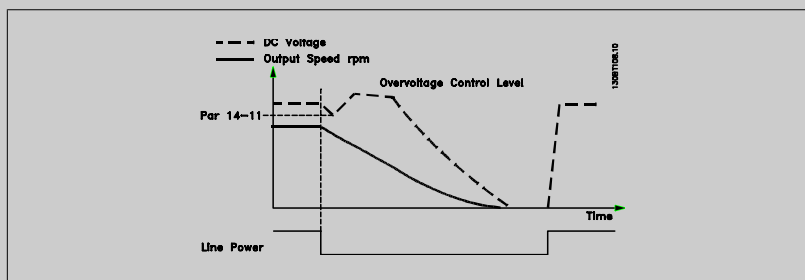
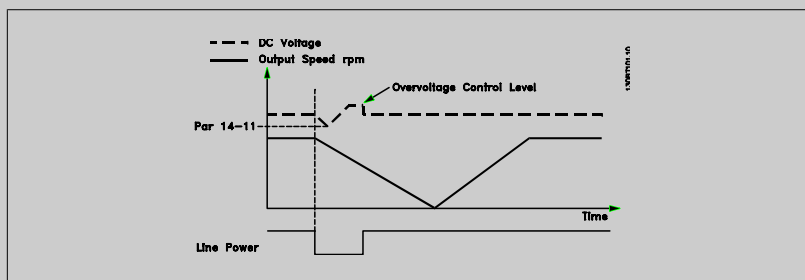

1. The power is back before the energy from DC / moment of inertia from load is too low. The adjustable frequency drive will perform a controlled ramp-down when par. 14-11 *Mains Voltage at Mains Fault* level has been reached.
2. The adjustable frequency drive will perform a controlled ramp-down as long as energy in the DC link is present. After this point, the motor will be coasted.

Kinetic backup:

The adjustable frequency drive will perform a kinetic backup. If par. 2-10 *Brake Function* is *Off*[0] or *AC brake* [2], the ramp will follow the Overvoltage Ramping. If par. 2-10 *Brake Function* is [1] *Resistor Brake* the ramp will follow the setting in par. 3-81 *Quick Stop Ramp Time*.

Kinetic Backup [4]: The adjustable frequency drive will keep on running as long as there is energy in the system due to the moment of inertia produced by the load.

Kinetic Backup [5]: The adjustable frequency drive will ride through on speed as long as the energy is present from moment of inertia from the load. If the DC voltage goes below par. 14-11 *Mains Voltage at Mains Fault*, the adjustable frequency drive will perform a trip.

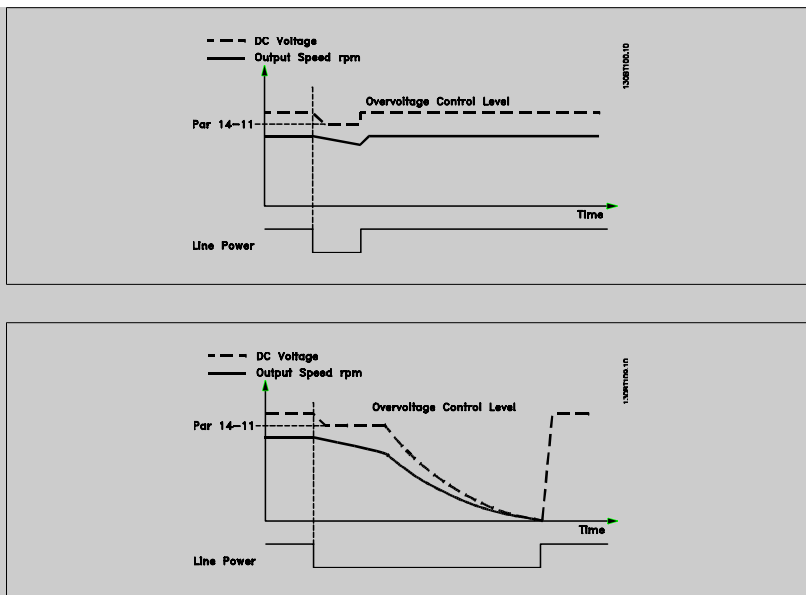

- [0] * No function
- [1] Ctrl. ramp-down
- [2] Ctrl. ramp-down, trip
- [3] Coasting
- [4] Kinetic backup
- [5] Kinetic backup, trip
- [6] Alarm

14-11 Mains Voltage at Mains Fault

Range: Application [180 - 600 V]
Function: dependent*

14-12 Function at Mains Imbalance

Operating under severe line imbalance conditions reduces the lifetime of the motor. Conditions are considered severe if the motor operates continuously near nominal load (such as when a pump or fan runs near full speed).

Option:	Function:
[0] * Trip	Trips the adjustable frequency drive.
[1] Warning	Issues a warning.
[2] Disabled	No action

3.15.4 14-2* Trip Reset

Parameters for configuring auto reset handling, special trip handling and control card self test or initialization.

14-20 Reset Mode

Option: **Function:**
 Select the reset function after tripping. Once reset, the adjustable frequency drive can be restarted.

[0] *	Manual reset	Select <i>Manual reset</i> [0], to perform a reset via [RESET] or via the digital inputs.
[1]	Automatic reset x 1	Select <i>Automatic reset x 1...x20</i> [1]-[12] to perform between one and twenty automatic resets after tripping.
[2]	Automatic reset x 2	
[3]	Automatic reset x 3	
[4]	Automatic reset x 4	
[5]	Automatic reset x 5	
[6]	Automatic reset x 6	
[7]	Automatic reset x 7	
[8]	Automatic reset x 8	
[9]	Automatic reset x 9	
[10]	Automatic reset x 10	
[11]	Automatic reset x 15	
[12]	Automatic reset x 20	
[13]	Infinite auto reset	Select <i>Infinite Automatic Reset</i> [13] for continuous resetting after tripping.

 **NOTE!**
 The motor may start without warning. If the specified number of AUTOMATIC RESETs is reached within 10 minutes, the adjustable frequency drive enters Manual reset [0] mode. After the Manual reset is performed, the setting of par. 14-20 *Reset Mode* reverts to the original selection. If the number of automatic resets is not reached within 10 minutes, or when a Manual reset is performed, the internal AUTOMATIC RESET counter returns to zero.

 **NOTE!**
 Automatic reset will also be active for resetting safe stop function in firmware version < 4.3x.

 **NOTE!**
 The setting in par. 14-20 *Reset Mode* is disregarded if fire mode is active (see par. 24-0*, Fire Mode).

14-21 Automatic Restart Time

Range: 10 s* [0 - 600 s] **Function:** Enter the time interval from trip to start of the automatic reset function. This parameter is active when par. 14-20 *Reset Mode* is set to *Automatic reset* [1] - [13].

14-22 Operation Mode

Option: **Function:** Use this parameter to specify normal operation, to perform tests, or to initialize all parameters except par. 15-03 *Power-ups*, par. 15-04 *Over Temps* and par. 15-05 *Over Volts*. This function is active only when the power is cycled to the adjustable frequency drive.
 Select *Normal operation* [0] for normal operation of the adjustable frequency drive with the motor in the selected application.
 Select *Control card test* [1] to test the analog and digital inputs and outputs and the +10 V control voltage. The test requires a test connector with internal connections. Use the following procedure for the control card test:

1. Select *Control card test* [1].
2. Disconnect the line power supply and wait for the light in the display to go out.
3. Set switches S201 (A53) and S202 (A54) = 'ON' / I.
4. Insert the test plug (see below).
5. Connect to the line power supply.
6. Carry out various tests.
7. The results are displayed on the LCP and the adjustable frequency drive moves into an infinite loop.
8. Par. 14-22 *Operation Mode* is automatically set to normal operation. Carry out a power cycle to start up in normal operation after a control card test.

If the test is OK:

LCP readout: Control Card OK.

Disconnect the line power supply and remove the test plug. The green LED on the control card will light up.

If the test fails:

LCP readout: Control Card I/O failure.

Replace the adjustable frequency drive or control card. The red LED on the control card is turned on. Test plugs (connect the following terminals to each other): 18 - 27 - 32; 19 - 29 - 33; 42 - 53 - 54

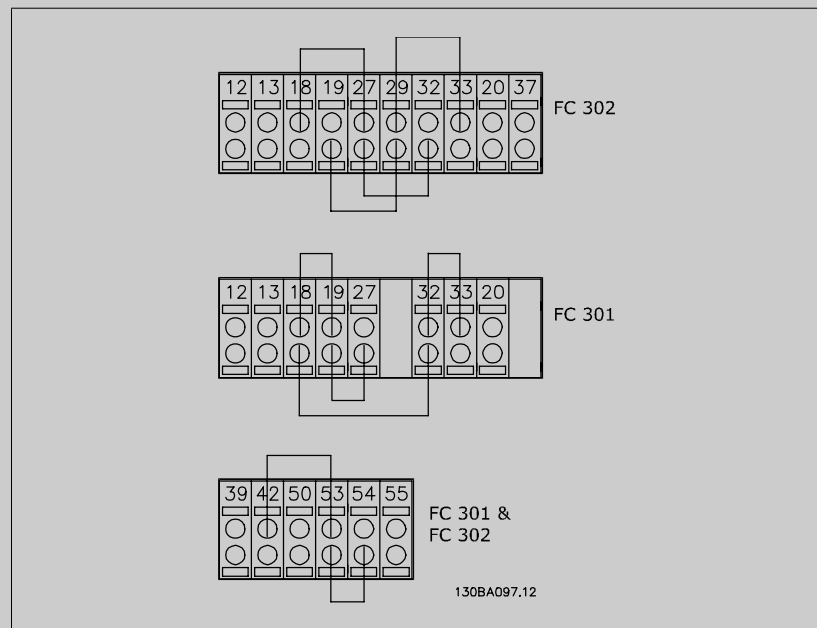

Select *Initialization* [2] to reset all parameter values to default settings, except for par. 15-03 *Power-ups*, par. 15-04 *Over Temps*, and par. 15-05 *Over Volts*. The adjustable frequency drive will reset during the next power-up.

Par. 14-22 *Operation Mode* will also revert to the default setting *Normal operation* [0].

[0] * Normal operation

[1] Control card test

[2] Initialization

[3] Boot mode

14-24 Trip Delay at Current Limit

Range:	Function:
60 s* [0 - 60 s]	Enter the current limit trip delay in seconds. When the output current reaches the current limit (par. 4-18 <i>Current Limit</i>), a warning is triggered. When the current limit warning has been continuously present for the period specified in this parameter, the adjustable frequency drive trips. Disable the trip delay by setting the parameter to 60 s = OFF. Thermal monitoring of the adjustable frequency drive will still remain active.

14-25 Trip Delay at Torque Limit

Range:	Function:
60 s* [0 - 60 s]	Enter the torque limit trip delay in seconds. When the output torque reaches the torque limits (par. 4-16 <i>Torque Limit Motor Mode</i> and par. 4-17 <i>Torque Limit Generator Mode</i>), a warning is triggered. When the torque limit warning has been continuously present for the period specified in this parameter, the adjustable frequency drive trips. Disable the trip delay by setting the parameter to 60 s = OFF. Thermal monitoring of the adjustable frequency drive will still remain active.

14-26 Trip Delay at Inverter Fault

Range:	Function:
Application dependent* [0 - 35 s]	When the adjustable frequency drive detects an overvoltage in the set time, tripping will be affected after the set time. If value = 0, <i>protection mode</i> is disabled



NOTE!
It is recommended to disable *protection mode* in hoisting applications.

14-29 Service Code

Range:	Function:
0* [-2147483647 - 2147483647]	For internal service only.

3.15.5 14-3* Current Limit Control

The adjustable frequency drive features an integral current limit controller which is activated when the motor current, and thus the torque, is higher than the torque limits set in par. 4-16 *Torque Limit Motor Mode* and par. 4-17 *Torque Limit Generator Mode*.

When the current limit is reached during motor operation or regenerative operation, the adjustable frequency drive will try to reduce torque below the preset torque limits as quickly as possible without losing control of the motor.

While the current control is active, the adjustable frequency drive can only be stopped by setting a digital input to *Coast inverse* [2] or *Coast and reset inv.* [3]. Any signal on terminals 18 to 33 will not be active until the adjustable frequency drive is no longer near the current limit.

By using a digital input set to *Coast inverse* [2] or *Coast and reset inv.* [3], the motor does not use the ramp-down time, since the adjustable frequency drive is coasted. If a quick stop is necessary, use the mechanical brake control function along with an external electro-mechanical brake attached to the application.

14-30 Current Lim Cont, Proportional Gain

Range:	Function:
100 %* [0 - 500 %]	Enter the proportional gain value for the current limit controller. Selection of a high value makes the controller react faster. Too high a setting leads to controller instability.

14-31 Current Lim Contr, Integration Time

Range:

0.020 s* [0.002 - 2.000 s]

Function:

Controls the current limit control integration time. Setting it to a lower value makes it react faster. A setting too low leads to control instability.

14-32 Current Lim Ctrl, Filter Time

Range:

1.0 ms* [1.0 - 100.0 ms]

Function:

14-35 Stall Protection

Option:

Select Enable [1] to enable the stall protection in field-weakening in flux mode. Select Disable [0] if you desire to disable it. This might cause the motor to be lost. Par 14-35 is active in flux mode only.

[0] Disabled

[1]* Enabled

3.15.6 14-4* Energy Optimizing

Parameters for adjusting the energy optimization level in both Variable Torque (VT) and Automatic Energy Optimization (AEO) mode in par. 1-03 *Torque Characteristics*.

14-40 VT Level

Range:

66 %* [40 - 90 %]

Function:

Enter the level of motor magnetization at low speed. Selection of a low value reduces energy loss in the motor, but also reduces load capability. This parameter cannot be adjusted while the motor is running.

14-41 AEO Minimum Magnetization

Range:
Application [40 - 75 %]
dependent*
Function:

Enter the minimum allowable magnetization for AEO. Selection of a low value reduces energy loss in the motor, but can also reduce resistance to sudden load changes.

14-42 Minimum AEO Frequency

Range:

10 Hz* [5 - 40 Hz]

Function:

Enter the minimum frequency at which the Automatic Energy Optimization (AEO) is to be active.

14-43 Motor Cos-Phi

Range:
Application [0.40 - 0.95]
dependent*
Function:

The Cos(phi) setpoint is automatically set for optimum AEO performance. This parameter should normally not be altered. However, in some situations it may be necessary to enter a new value to fine tune.

3.15.7 14-5* Environment

These parameters help the adjustable frequency drive to operate under special environmental conditions.

14-50 RFI 1

Option:

Function:

[0] Off

Select *Off* [0] only if the adjustable frequency drive is fed by an isolated line power source, i.e., from a special IT line power source.

In this mode, the internal RFI filter capacitors between chassis and the line power RFI filter circuit are cut out to avoid damage to the intermediate circuit and to reduce the ground capacity currents according to IEC 61800-3.

[1] * On

Select *On* [1] to ensure that the adjustable frequency drive complies with EMC standards.

14-51 DC Link Compensation

Option:

Function:

[0] Off

Disables DC Link Compensation.

[1] * On

Enables DC Link Compensation.

14-52 Fan Control

Select minimum speed of the main fan.

Select *Auto* [0] to run fan only when internal temperature in adjustable frequency drive is in the range of 95°F [35°C] to approximately 131°F [55°C]. Fan runs at low speed below 95°F [35°C], and at full speed at approximately 131°F [55°C].

Option:

Function:

[0] * Auto

[1] On 50%

[2] On 75%

[3] On 100%

14-53 Fan Monitor

Option:

Function:

Select which action the adjustable frequency drive should take in case a fan fault is detected.

[0] Disabled

[1] * Warning

[2] Trip

14-55 Output Filter

Option:

Function:

Select the type of output filter connected. This parameter cannot be adjusted while motor is running.

[0] * No Filter

[1] Sine-Wave Filter

14-56 Capacitance Output Filter

Range:

Function:

2.0 uF* [0.1 - 6500.0 uF]

Set the capacitance of the output filter. The value can be found on the filter label.



NOTE!

This is required for correct compensation in flux mode (par. 1-01 *Motor Control Principle*)

14-57 Inductance Output Filter

Range:

7.000 mH* [0.001 - 65.000 mH]

Function:

Set the inductance of the output filter. The value can be found on the filter label.

NOTE!
This is required for correct compensation in flux mode (par. 1-01 *Motor Control Principle*)

3.15.8 14-7* Compatibility

This parameter is used for setting the compatibility for the VLT 3000, VLT 5000 to the FC 300

14-72 VLT Alarm Word

Option:

[0] 0 - 4294967295

Function:

Read out the alarm word corresponding to VLT 5000

14-73 VLT Warning Word

Option:

[0] 0 - 4294967295

Function:

Read out the warning word corresponding to VLT 5000

14-74 VLT Ext. Status Word

Range:

0* [0 - 4294967295]

Function:

Read out the ext. status word corresponding to VLT 5000

3.15.9 14-8* Options

14-80 Option Supplied by External 24VDC

Option:

[0] No

Function:

Select No [0] to use the drive's 24 V DC supply.

[1] * Yes

Select Yes [1] if an external 24 V DC supply will be used to power the option. Inputs/outputs will be galvanically isolated from the drive when operated from an external supply.

NOTE!

This parameter is only changing function by performing a power cycle.

14-90 Fault Level

Option:

[0] * Off

Function:

Use this parameter to customize fault levels. Use [0] "Off" with caution as it will ignore all warnings and alarms for the chosen source.

[1] Warning

[2] Trip

[3] Trip Lock

3.16 Parameters: Drive Information

3.16.1 15-** Drive Information

Parameter group containing adjustable frequency drive information such as operating data, hardware configuration and software versions.

3.16.2 15-0* Operating Data

Parameter group containing operating data, such as operating hours, kWh counters, power-ups, etc.

15-00 Operating Hours		
Range:		Function:
0 h* [0 - 2147483647 h]		View how many hours the adjustable frequency drive has run. The value is saved when the adjustable frequency drive is turned off.
15-01 Running Hours		
Range:		Function:
0 h* [0 - 2147483647 h]		View how many hours the motor has run. Reset the counter in par. 15-07 <i>Reset Running Hours Counter</i> . The value is saved when the adjustable frequency drive is turned off.
15-02 kWh Counter		
Range:		Function:
0 kWh* [0 - 2147483647 kWh]		Registering the power consumption of the motor as a mean value over one hour. Reset the counter in par. 15-06 <i>Reset kWh Counter</i> .
15-03 Power-ups		
Range:		Function:
0 N/A* [0 - 2147483647 N/A]		View the number of times the adjustable frequency drive has been powered up.
15-04 Over Temps		
Range:		Function:
0 N/A* [0 - 65535 N/A]		View the number of adjustable frequency drive temperature faults which have occurred.
15-05 Over Volts		
Range:		Function:
0 N/A* [0 - 65535 N/A]		View the number of adjustable frequency drive overvoltages which have occurred.
15-06 Reset kWh Counter		
Option:		Function:
[0] * Do not reset		Select <i>Do not reset</i> [0] if no reset of the kWh counter is desired.
[1] Reset counter		Select <i>Reset</i> [1] and press [OK] to reset the kWh counter to zero (see par. 15-02 <i>kWh Counter</i>).

NOTE!
The reset is carried out by pressing [OK].

15-07 Reset Running Hours Counter

Option:	Function:
[0] * Do not reset	
[1] Reset counter	Select <i>Reset</i> [1] and press [OK] to reset the Running Hours counter to zero (see par. 15-01 <i>Running Hours</i>). This parameter cannot be selected via the serial port, RS-485. Select <i>Do not reset</i> [0] if no reset of the Running Hours counter is desired.

3

3.16.3 15-1* Data Log Settings

The Data Log enables continuous logging of up to 4 data sources (par. 15-10 *Logging Source*) at individual rates (par. 15-11 *Logging Interval*). A trigger event (par. 15-12 *Trigger Event*) and window (par. 15-14 *Samples Before Trigger*) are used to start and stop the logging conditionally.

15-10 Logging Source

Array [4]

Option:	Function:
	Select which variables are to be logged.

[0] * None
[1472] VLT Alarm Word
[1473] VLT Warning Word
[1474] VLT Ext. Status Word
[1600] Control Word
[1601] Reference [Unit]
[1602] Reference %
[1603] Status Word
[1610] Power [kW]
[1611] Power [hp]
[1612] Motor voltage
[1613] Frequency
[1614] Motor Current
[1616] Torque [Nm]
[1617] Speed [RPM]
[1618] Motor Thermal
[1622] Torque [%]
[1625] Torque [Nm] High
[1630] DC Link Voltage
[1632] Brake Energy /s
[1633] Brake Energy /2 min
[1634] Heatsink Temp.
[1635] Inverter Thermal
[1650] External Reference
[1651] Pulse Reference
[1652] Feedback [Unit]
[1660] Digital Input
[1662] Analog Input 53

[1664]	Analog Input 54
[1665]	Analog Output 42 [mA]
[1666]	Digital Output [bin]
[1675]	Analog In X30/11
[1676]	Analog In X30/12
[1677]	Analog Out X30/8 [mA]
[1690]	Alarm Word
[1692]	Warning Word
[1694]	Ext. Status Word
[3470]	MCO Alarm Word 1
[3471]	MCO Alarm Word 2

15-11 Logging Interval

Range: **Function:**

Application [Application dependant]
dependent*

15-12 Trigger Event

Select the trigger event. When the trigger event occurs, a window is applied to freeze the log. The log will then retain a specified percentage of samples before the occurrence of the trigger event (par. 15-14 *Samples Before Trigger*).

Option: **Function:**

[0] *	FALSE
[1]	TRUE
[2]	Running
[3]	In range
[4]	On reference
[5]	Torque limit
[6]	Current limit
[7]	Out of current range
[8]	Below I low
[9]	Above I high
[10]	Out of speed range
[11]	Below speed low
[12]	Above speed high
[13]	Out of feedb. range
[14]	Below feedb. low
[15]	Above feedb. high
[16]	Thermal warning
[17]	Mains out of range
[18]	Reverse
[19]	Warning
[20]	Alarm (trip)
[21]	Alarm (trip lock)
[22]	Comparator 0
[23]	Comparator 1

[24]	Comparator 2
[25]	Comparator 3
[26]	Logic rule 0
[27]	Logic rule 1
[28]	Logic rule 2
[29]	Logic rule 3
[33]	Digital input DI18
[34]	Digital input DI19
[35]	Digital input DI27
[36]	Digital input DI29
[37]	Digital input DI32
[38]	Digital input DI33
[50]	Comparator 4
[51]	Comparator 5
[60]	Logic rule 4
[61]	Logic rule 5

15-13 Logging Mode

Option:
Function:

[0] *	Log always	Select <i>Log always</i> [0] for continuous logging.
[1]	Log once on trigger	Select <i>Log once on trigger</i> [1] to conditionally start and stop logging using par. 15-12 <i>Trigger Event</i> and par. 15-14 <i>Samples Before Trigger</i> .

15-14 Samples Before Trigger

Range:
Function:

50*	[0 - 100]	Enter the percentage of all samples prior to a trigger event which are to be retained in the log. See also par. 15-12 <i>Trigger Event</i> and par. 15-13 <i>Logging Mode</i> .
-----	------------	---

3.16.4 15-2* Historic Log

View up to 50 logged data items via the array parameters in this parameter group. For all parameters in the group, [0] is the most recent data and [49] the oldest data. Data is logged every time an *event* occurs (not to be confused with SLC events). *Events* in this context are defined as a change in one of the following areas:

1. Digital input
2. Digital outputs (not monitored in this SW release)
3. Warning word
4. Alarm word
5. Status word
6. Control word
7. Extended status word

Events are logged with value, and time stamp in msec. The time interval between two events depends on how often *events* occur (maximum once every scan time). Data logging is continuous but if an alarm occurs, the log is saved and the values can be viewed on the display. This feature is useful, for example when carrying out service following a trip. View the historic log contained in this parameter via the serial communication port or via the display.

15-20 Historic Log: Event

Array [50]

Range:

0 N/A* [0 - 255 N/A]

Function:

View the event type of the logged events.

15-21 Historic Log: Value

Array [50]

Range:

0 N/A* [0 - 2147483647 N/A]

Function:

View the value of the logged event. Interpret the event values according to this table:

Digital input	Decimal value. See par. 16-60 <i>Digital Input</i> for description after converting to binary value.
Digital output (not monitored in this SW release)	Decimal value. See par. 16-66 <i>Digital Output [bin]</i> for description after converting to binary value.
Warning word	Decimal value. See par. 16-92 <i>Warning Word</i> for description.
Alarm word	Decimal value. See par. 16-90 <i>Alarm Word</i> for description.
Status word	Decimal value. See par. 16-03 <i>Status Word</i> for description after converting to binary value.
Control word	Decimal value. See par. 16-00 <i>Control Word</i> for description.
Extended status word	Decimal value. See par. 16-94 <i>Ext. Status Word</i> for description.

15-22 Historic Log: Time

Array [50]

Range:

0 ms* [0 - 2147483647 ms]

Function:

View the time at which the logged event occurred. Time is measured in ms since adjustable frequency drive start. The max. value corresponds to approx. 24 days which means that the count will restart at zero after this time period.

3.16.5 15-3* Alarm Log

Parameters in this group are array parameters, where up to 10 fault logs can be viewed. [0] is the most recent logged data, and [9] the oldest. Error codes, values and time stamp can be viewed for all logged data.

15-30 Fault Log: Error Code

Array [10]

Range:

0* [0 - 255]

Function:

View the error code and look up its meaning in the *Troubleshooting* chapter of the FC 300 Design Guide.

15-31 Alarm Log: Value

Array [10]

Range:

0 N/A* [-32767 - 32767 N/A]

Function:

View an extra description of the error. This parameter is mostly used in combination with alarm 38 'internal fault'.

15-32 Alarm Log: Time

Array [10]

Range:

0 s* [0 - 2147483647 s]

Function:

View the time when the logged event occurred. Time is measured in seconds from adjustable frequency drive start-up.

3

3.16.6 15-4* Drive Identification

Parameters containing read only information about the hardware and software configuration of the adjustable frequency drive.

15-40 FC Type

Range:

0* [0 - 0]

Function:

View the adjustable frequency drive type. The readout is identical to the FC 300 Series power field of the type code definition, characters 1-6.

15-41 Power Section

Range:

0* [0 - 0]

Function:

View the adjustable frequency drive type. The readout is identical to the FC 300 Series power field of the type code definition, characters 7-10.

15-42 Voltage

Range:

0* [0 - 0]

Function:

View the adjustable frequency drive type. The readout is identical to the FC 300 Series power field of the type code definition, characters 11-12.

15-43 Software Version

Range:

0 N/A* [0 - 0 N/A]

Function:

View the combined SW version (or 'package version') consisting of power SW and control SW.

15-44 Ordered Typecode String

Range:

0 N/A* [0 - 0 N/A]

Function:

View the type code string used for re-ordering the adjustable frequency drive in its original configuration.

15-45 Actual Typecode String

Range:

0 N/A* [0 - 0 N/A]

Function:

View the actual type code string.

15-46 Adj Freq Dr Ordering No.

Range:

0 N/A* [0 - 0 N/A]

Function:

View the 8-digit ordering number used for re-ordering the adjustable frequency drive in its original configuration.

15-47 Power Card Ordering No.

Range:

0 N/A* [0 - 0 N/A]

Function:

View the power card ordering number.

15-48 LCP ID Num.		
Range:		Function:
0 N/A* [0 - 0 N/A]		View the LCP ID number.
15-49 SW ID Control Card		
Range:		Function:
0 N/A* [0 - 0 N/A]		View the control card software version number.
15-50 SW ID Power Card		
Range:		Function:
0 N/A* [0 - 0 N/A]		View the power card software version number.
15-51 Adj Freq Dr Serial No.		
Range:		Function:
0 N/A* [0 - 0 N/A]		View the adjustable frequency drive serial number.
15-53 Power Card Serial Number		
Range:		Function:
0 N/A* [0 - 0 N/A]		View the power card serial number.

3.16.7 15-6* Option Ident.

This read-only parameter group contains information about the hardware and software configuration of the options installed in slots A, B C0 and C1.

15-60 Option Mounted		
Range:		Function:
0 N/A* [0 - 0 N/A]		View the installed option type.
15-61 Option SW Version		
Range:		Function:
0 N/A* [0 - 0 N/A]		View the installed option software version.
15-62 Option Ordering No		
Range:		Function:
0 N/A* [0 - 0 N/A]		Shows the ordering number for the installed options.
15-63 Option Serial No		
Range:		Function:
0 N/A* [0 - 0 N/A]		View the installed option serial number.

3.16.8 15-9* Parameter Info

Parameter lists

15-92 Defined Parameters

Array [1000]

Range:

0 N/A* [0 - 9999 N/A]

Function:

View a list of all defined parameters in the adjustable frequency drive. The list ends with 0.

15-93 Modified Parameters

Array [1000]

Range:

0 N/A* [0 - 9999 N/A]

Function:

View a list of the parameters that have been changed from their default setting. The list ends with 0. Changes may not be visible until up to 30 seconds after implementation.

15-99 Parameter Metadata

Array [30]

Range:

0* [0 - 9999]

Function:

This parameter contains data used by the MCT10 software tool.

3.17 Parameters: Data Readouts

3.17.1 16-** Data Readouts

Parameter group for data readouts, such as current references, voltages, control, alarm, warning and status words.

3.17.2 16-0* General Status

Parameters for reading the general status, such as the calculated reference, the active control word and status.

16-00 Control Word

Range:

0 N/A* [0 - 65535 N/A]

Function:

View the control word sent from the adjustable frequency drive via the serial communication port in hex code.

16-01 Reference [Unit]

Range:

0.000 Ref- [-999999.000 - 999999.000 ReferenceFeed-enceFeedbackUnit] backUnit*

Function:

View the present reference value applied on impulse or analog basis in the unit resulting from the configuration selected in par. 1-00 *Configuration Mode* (Hz, Nm or RPM).

16-02 Reference %

Range:

0.0 %* [-200.0 - 200.0 %]

Function:

16-03 Status Word

Range:

0 N/A* [0 - 65535 N/A]

Function:

View the status word sent from the adjustable frequency drive via the serial communication port in hex code.

16-05 Main Actual Value [%]		
Range:		Function:
0.00 %* [-100.00 - 100.00 %]		View the two-byte word sent with the status word to the bus master reporting the main actual value.

16-09 Custom Readout		
Range:		Function:
0.00 Cus- tomReadoutUnit* [0.00 - 0.00 CustomReadoutUnit]		View the value of custom readout from par. 0-30 <i>Unit for User-defined Readout</i> to par. 0-32 <i>Custom Readout Max Value</i>

3.17.3 16-1* Motor Status

Parameters for reading the motor status values.

16-10 Power [kW]		
Range:		Function:
0.00 kW* [0.00 - 10000.00 kW]		Displays motor power in kW. The value shown is calculated on the basis of the actual motor voltage and motor current. The value is filtered, and therefore approx. 30 ms may pass from when an input value changes to when the data readout values change. The resolution of readout value on serial communication bus is in 10 W steps.

16-11 Power [hp]		
Range:		Function:
0.00 hp* [0.00 - 10000.00 hp]		View the motor power in HP. The value shown is calculated on the basis of the actual motor voltage and motor current. The value is filtered, and therefore approximately 30 ms may pass from when an input value changes to when the data readout values change.

16-12 Motor voltage		
Range:		Function:
0.0 V* [0.0 - 6000.0 V]		View the motor voltage, a calculated value used for controlling the motor.

16-13 Frequency		
Range:		Function:
0.0 Hz* [0.0 - 6500.0 Hz]		View the motor frequency, without resonance dampening.

16-14 Motor Current		
Range:		Function:
0.00 A* [0.00 - 10000.00 A]		View the motor current measured as a mean value, IRMS. The value is filtered, and thus approximately 30 ms may pass from when an input value changes to when the data readout values change.

16-15 Frequency [%]		
Range:		Function:
0.00 %* [-100.00 - 100.00 %]		

16-16 Torque [Nm]		
Range:		Function:
0.0 Nm* [-3000.0 - 3000.0 Nm]		View the torque value with sign, applied to the motor shaft. Linearity is not exact between 160% motor current and torque in relation to the rated torque. Some motors supply more than 160% torque. Consequently, the min. value and the max. value will depend on the max. motor current as

well as the motor used. The value is filtered, and thus approx. 30 ms may pass from when an input changes value to when the data readout values change.

16-17 Speed [RPM]

Range:

0 RPM* [-30000 - 30000 RPM]

Function:

View the actual motor RPM. In open-loop or closed-loop process control, the motor RPM is estimated. In speed closed-loop modes, the motor RPM is measured.

16-18 Motor Thermal

Range:

0 %* [0 - 100 %]

Function:

View the calculated thermal load on the motor. The cut-out limit is 100%. The basis for calculation is the ETR function selected in par. 1-90 *Motor Thermal Protection*.

16-19 KTY sensor temperature

Range:

0 C* [0 - 0 C]

Function:

16-20 Motor Angle

Range:

0* [0 - 65535]

Function:

View the current encoder/resolver angle offset relative to the index position. The value range of 0-65535 corresponds to $0-2\pi$ (radians).

16-22 Torque [%]

Range:

0 %* [-200 - 200 %]

Function:

Value shown is the torque as a percentage of nominal torque, with sign, applied to the motor shaft.

16-25 Torque [Nm] High

Range:

0.0 Nm* [-200000000.0 - 200000000.0 Nm]

Function:

View the torque value with sign, applied to the motor shaft. Some motors supply more than 160% torque. Consequently, the min. value and the max. value will depend on the max. motor current as well as the motor used. This specific readout has been adapted to show higher values than the standard readout in par. 16-16 *Torque [Nm]*.

3.17.4 16-3* Drive Status

Parameters for reporting the status of the adjustable frequency drive.

16-30 DC Link Voltage

Range:

0 V* [0 - 10000 V]

Function:

View a measured value. The value is filtered with an 30 ms time constant.

16-32 Brake Energy /s

Range:

0.000 kW* [0.000 - 10000.000 kW]

Function:

View the braking energy transmitted to an external brake resistor, stated as an instantaneous value.

16-33 Brake Energy /2 min

Range:

0.000 kW* [0.000 - 10000.000 kW]

Function:

View the braking energy transmitted to an external brake resistor. The mean power is calculated on an average basis for the most recent 120 seconds.

16-34 Heatsink Temp.		
Range:		Function:
0 C*	[0 - 255 C]	
16-35 Inverter Thermal		
Range:		Function:
0 %*	[0 - 100 %]	View the percentage load on the inverter.
16-36 Inv. Nom. Current		
Range:		Function:
Application dependent*	[0.01 - 10000.00 A]	View the inverter nominal current, which should match the nameplate data on the connected motor. The data are used for calculation of torque, motor protection, etc.
16-37 Inv. Max. Current		
Range:		Function:
Application dependent*	[0.01 - 10000.00 A]	View the inverter maximum current, which should match the nameplate data on the connected motor. The data are used for calculation of torque, motor protection, etc.
16-38 SL Controller State		
Range:		Function:
0*	[0 - 100]	View the state of the event under execution by the SL controller.
16-39 Control Card Temp.		
Range:		Function:
0 C*	[0 - 100 C]	
16-40 Logging Buffer Full		
Option:		Function:
		View whether the logging buffer is full (see parameter group 15-1*). The logging buffer will never be full when par. 15-13 <i>Logging Mode</i> is set to <i>Log always</i> [0].
[0] *	No	
[1]	Yes	
16-49 Current Fault Source		
Range:		Function:
0 N/A*	[0 - 8 N/A]	Value indicates source of current faults including short circuit, overcurrent, and phase imbalance (from left): 1-4 Inverter 5-8 Rectifier 0 No fault recorded

3.17.5 16-5* Ref. & Feedb.

Parameters for reporting the reference and feedback input.

16-50 External Reference**Range:**

0.0* [-200.0 - 200.0]

Function:

View the total reference, the sum of digital, analog, preset, bus and freeze references, plus catch-up and slow-down.

16-51 Pulse Reference**Range:**

0.0* [-200.0 - 200.0]

Function:

View the reference value from programmed digital input(s). The readout can also reflect the impulses from an incremental encoder.

16-52 Feedback [Unit]**Range:**

0.000 Ref- [-999999.999 - 999999.999 ReferenceFeed-enceFeedbackUnit] backUnit*

Function:View the feedback unit resulting from the selection of unit and scaling in par. 3-00 *Reference Range*, par. 3-01 *Reference/Feedback Unit*, par. 3-02 *Minimum Reference* and par. 3-03 *Maximum Reference*.**16-53 Digi Pot Reference****Range:**

0.00* [-200.00 - 200.00]

Function:

View the contribution of the digital potentiometer to the actual reference.

3.17.6 16-6* Inputs and Outputs

Parameters for reporting the digital and analog IO ports.

16-60 Digital Input**Range:**

0 N/A* [0 - 1023 N/A]

Function:

View the signal states from the active digital inputs. Example: Input 18 corresponds to bit no. 5, '0' = no signal, '1' = connected signal. Bit 6 works in the opposite way, on = '0', off = '1' (safe stop input).

Bit 0	Digital input term. 33
Bit 1	Digital input term. 32
Bit 2	Digital input term. 29
Bit 3	Digital input term. 27
Bit 4	Digital input term. 19
Bit 5	Digital input term. 18
Bit 6	Digital input term. 37
Bit 7	Digital input GP I/O term. X30/4
Bit 8	Digital input GP I/O term. X30/3
Bit 9	Digital input GP I/O term. X30/2
Bit 10-63	Reserved for future terminals

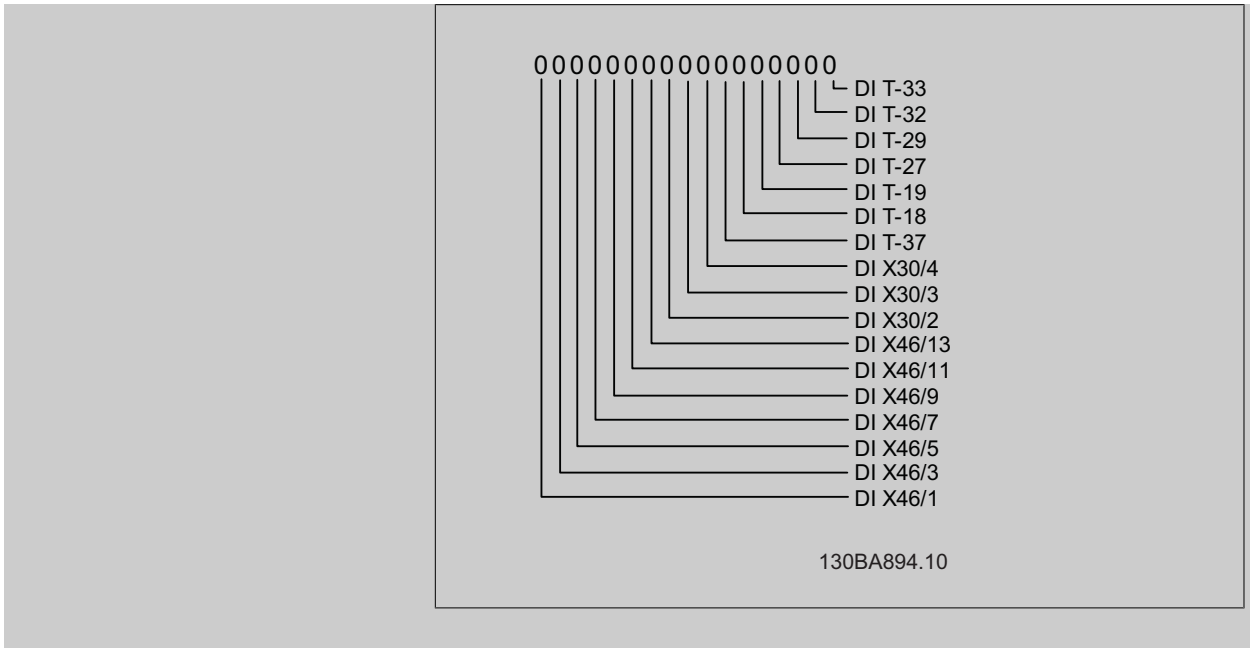

16-61 Terminal 53 Switch Setting

Option:	Function:
	View the setting of input terminal 53. Current = 0; Voltage = 1.
[0] * Current	
[1] Voltage	
[2] Pt 1000 [°C]	
[3] Pt 1000 [°F]	
[4] Ni 1000 [°C]	
[5] Ni 1000 [°F]	

16-62 Analog Input 53

Range:	Function:
0.000* [-20.000 - 20.000]	View the actual value at input 53.

16-63 Terminal 54 Switch Setting

Option:	Function:
	View the setting of input terminal 54. Current = 0; Voltage = 1.
[0] * Current	
[1] Voltage	
[2] Pt 1000 [°C]	
[3] Pt 1000 [°F]	
[4] Ni 1000 [°C]	
[5] Ni 1000 [°F]	

16-64 Analog Input 54

Range:	Function:
0.000* [-20.000 - 20.000]	View the actual value at input 54.

16-65 Analog Output 42 [mA]**Range:**

0.000* [0.000 - 30.000]

Function:View the actual value at output 42 in mA. The value shown reflects the selection in par. 6-50 *Terminal 42 Output*.**16-66 Digital Output [bin]****Range:**

0* [0 - 15]

Function:

View the binary value of all digital outputs.

16-67 Pulse Input #29 [Hz]**Range:**

0 N/A* [0 - 130000 N/A]

Function:

View the actual frequency rate on terminal 29.

16-68 Freq. Input #33 [Hz]**Range:**

0* [0 - 130000]

Function:

View the actual value of the frequency applied at terminal 33 as an impulse input.

16-69 Pulse Output #27 [Hz]**Range:**

0* [0 - 40000]

Function:

View the actual value of pulses applied to terminal 27 in digital output mode.

16-70 Pulse Output #29 [Hz]**Range:**

0* [0 - 40000]

Function:View the actual value of pulses at terminal 29 in digital output mode.
This parameter is available for the FC 302 only.**16-71 Relay Output [bin]****Range:**

0 N/A* [0 - 511 N/A]

Function:

View the settings of all relays.

Readout choice [P16-71]:

Relay output [bin]:

00000 bin

- OptionB card relay 09
- OptionB card relay 08
- OptionB card relay 07
- Power card relay 02
- Power card relay 01

130BA195.10

16-72 Counter A**Range:**

0* [-2147483648 - 2147483647]

Function:View the present value of Counter A. Counters are useful as comparator operands, see par. 13-10 *Comparator Operand*.
The value can be reset or changed either via digital inputs (parameter group 5-1*) or by using an SLC action (par. 13-52 *SL Controller Action*).

16-73 Counter B		
Range:	Function:	
0* [-2147483648 - 2147483647]	View the present value of Counter B. Counters are useful as comparator operands (par. 13-10 <i>Comparator Operand</i>). The value can be reset or changed either via digital inputs (parameter group 5-1*) or by using an SLC action (par. 13-52 <i>SL Controller Action</i>).	
16-74 Prec. Stop Counter		
Range:	Function:	
0* [0 - 2147483647]	Returns the actual counter value of precise counter (par. 1-84 <i>Precise Stop Counter Value</i>).	
16-75 Analog In X30/11		
Range:	Function:	
0.000 N/A* [-20.000 - 20.000 N/A]	View the actual value at input X30/11 of MCB 101.	
16-76 Analog In X30/12		
Range:	Function:	
0.000 N/A* [-20.000 - 20.000 N/A]	View the actual value at input X30/12 of MCB 101.	
16-77 Analog Out X30/8 [mA]		
Range:	Function:	
0.000 N/A* [0.000 - 30.000 N/A]	View the actual value at input X30/8 in mA.	
16-78 Analog Out X45/1 [mA]		
Range:	Function:	
0.000* [0.000 - 30.000]	View the actual value at output X45/1. The value shown reflects the selection in par. 6-70 <i>Terminal X45/1 Output</i> .	
16-79 Analog Out X45/3 [mA]		
Range:	Function:	
0.000* [0.000 - 30.000]	View the actual value at output X45/3. The value shown reflects the selection in par. 6-80 <i>Terminal X45/3 Output</i> .	

3.17.7 16-8* Ser. Com. Bus & Adjustable Frequency Drive Port

Parameters for reporting the BUS references and control words.

16-80 Fieldbus CTW 1		
Range:	Function:	
0 N/A* [0 - 65535 N/A]	View the two-byte control word (CTW) received from the bus master. Interpretation of the control word depends on the serial communication bus option installed and the control word profile selected in par. 8-10 <i>Control Profile</i> . For more information, refer to the relevant serial communication bus manual.	
16-82 Fieldbus REF 1		
Range:	Function:	
0 N/A* [-200 - 200 N/A]	View the two-byte word sent with the control word form the bus master to set the reference value. For more information, refer to the relevant serial communication bus manual.	

16-84 Comm. Option Status

Range:

0 N/A* [0 - 65535 N/A]

Function:

View the extended serial communication bus comm. option status word.
For more information, refer to the relevant serial communication bus manual.

16-85 FC Port CTW 1

Range:

0 N/A* [0 - 65535 N/A]

Function:

View the two-byte control word (CTW) received from the bus master. Interpretation of the control word depends on the serial communication bus option installed and the control word profile selected in par. 8-10 *Control Profile*.

16-86 FC Port REF 1

Range:

0 N/A* [-200 - 200 N/A]

Function:

View the two-byte status word (STW) sent to the bus master. Interpretation of the status word depends on the serial communication bus option installed and the control word profile selected in par. 8-10 *Control Profile*.

3.17.8 16-9* Diagnosis Readouts

Parameters displaying alarm, warning and extended status words.

16-90 Alarm Word

Range:

0 N/A* [0 - 4294967295 N/A]

Function:

View the alarm word sent via the serial communication port in hex code.

16-91 Alarm word 2

Range:

0* [0 - 4294967295]

Function:

View the alarm word sent via the serial communication port in hex code.

16-92 Warning Word

Range:

0 N/A* [0 - 4294967295 N/A]

Function:

View the warning word sent via the serial communication port in hex code.

16-93 Warning word 2

Range:

0* [0 - 4294967295]

Function:

View the warning word sent via the serial communication port in hex code.

16-94 Ext. Status Word

Range:

0* [0 - 4294967295]

Function:

Returns the extended warning word sent via the serial communication port in hex code.

3.18 Parameters: Encoder Input

3.18.1 17-** Motor Feedb. Option

Additional parameters to configure the Encoder (MCB102) or the Resolver (MCB103) Feedback Option.

3.18.2 17-1* Inc. Enc. Interface

Parameters in this group configure the incremental interface of the MCB102 option. Note that both the incremental and absolute interfaces are active at the same time.

17-10 Signal Type

Select the incremental type (A/B channel) of the encoder in use. Find the information on the encoder data sheet.

Select *None* [0] if the feedback sensor is an absolute encoder only.

This parameter cannot be adjusted while the motor is running.

Option: **Function:**

[0] None

[1] * TTL (5V, RS4222)

[2] SinCos

17-11 Resolution (PPR)

Range: **Function:**

1024* [10 - 10000]

Enter the resolution of the incremental track, i.e., the number of pulses or periods per revolution.
This parameter cannot be adjusted while the motor is running.

3.18.3 17-2* Abs. Enc. Interface

Parameters in this group configure the absolute interface of the MCB102 option. Note that both the incremental and absolute interfaces are active at the same time.

17-20 Protocol Selection

Select *HIPERFACE* [1] if the encoder is absolute only.

Select *None* [0] if the feedback sensor is an incremental encoder only.

This parameter cannot be adjusted while the motor is running.

Option: **Function:**

[0] * None

[1] HIPERFACE

[2] EnDat

[4] SSI

17-21 Resolution (Positions/Rev)

Select the resolution of the absolute encoder, i.e., the number of counts per revolution.

This parameter cannot be adjusted while the motor is running. The value depends on setting in par. 17-20 *Protocol Selection*.

Range: **Function:**

Application [Application dependant]
dependent*

17-24 SSI Data Length**Range:**

13* [13 - 25]

Function:

Set the number of bits for the SSI message. Choose 13 bits for single-turn encoders and 25 bits for multi-turn encoder.

17-25 Clock Rate**Range:**Application [Application dependant]
dependent***Function:****17-26 SSI Data Format****Option:**

[0] * Gray code

Function:

[1] Binary code

Set the data format of the SSI data. Choose between Gray or Binary format.

17-34 HIPERFACE Baud rate

Select the baud rate of the attached encoder.

This parameter cannot be adjusted while the motor is running. The parameter is only accessible when par. 17-20 *Protocol Selection* is set to HIPERFACE [1].**Option:**

[0] 600

Function:

[1] 1200

[2] 2400

[3] 4800

[4] * 9600

[5] 19200

[6] 38400

3.18.4 17-5* Resolver Interface

Parameter group 17-5* is used for setting parameters for the MCB 103 resolver option.

Usually the resolver feedback is used as motor feedback from permanent magnet motors with par. 1-01 *Motor Control Principle* set to Flux with motor feedback.

Resolver parameters cannot be adjusted while the motor is running.

17-50 Poles**Range:**

2* [2 - 2]

Function:Set the number of poles on the resolver.
The value is stated in the data sheet for resolvers.**17-51 Input Voltage****Range:**

7.0 V* [2.0 - 8.0 V]

Function:Set the input voltage to the resolver. The voltage is stated as an RMS value.
The value is stated in the data sheet for resolvers.**17-52 Input Frequency****Range:**

10.0 kHz* [2.0 - 15.0 kHz]

Function:

Set the input frequency to the resolver.

The value is stated in the data sheet for resolvers.

17-53 Transformation Ratio

Range:

0.5* [0.1 - 1.1]

Function:

Set the transformation ratio for the resolver.
The transformation ration is:

$$T_{ratio} = \frac{V_{Out}}{V_{In}}$$

The value is stated in the data sheet for resolvers.

3

17-59 Resolver Interface

Activate the MCB 103 resolver option when the resolver parameters are selected.

To avoid damage to resolvers, par. 17-50 *Poles* – par. 17-53 *Transformation Ratio* must be adjusted before activating this parameter.

Option:

Function:

[0] * Disabled

[1] Enabled

3.18.5 17-6* Monitoring and Application

This parameter group is used for selecting additional functions when the MCB 102 Encoder option or MCB 103 Resolver option is fitted into option slot B as speed feedback.

Monitoring and application parameters cannot be adjusted while the motor is running.

17-60 Feedback Direction

Change the detected encoder rotation direction without changing the wiring to the encoder.

This parameter cannot be adjusted while the motor is running.

Option:

Function:

[0] * Clockwise

[1] Counterclockwise

17-61 Feedback Signal Monitoring

Select which reaction the adjustable frequency drive should take if a faulty encoder signal is detected.

The encoder function in par. 17-61 *Feedback Signal Monitoring* is an electrical check of the hardware circuit in the encoder system.

Option:

Function:

[0] Disabled

[1] * Warning

[2] Trip

[3] Jog

[4] Freeze Output

[5] Max Speed

[6] Switch to Open Loop

[7] Select Setup 1

[8] Select Setup 2

[9] Select Setup 3

[10] Select Setup 4

[11] stop & trip

3.19 Parameters: Data Readouts 2

18-90 Process PID Error	
Range:	Function:
0.0 %* [-200.0 - 200.0 %]	
18-91 Process PID Output	
Range:	Function:
0.0 %* [-200.0 - 200.0 %]	
18-92 Process PID Clamped Output	
Range:	Function:
0.0 %* [-200.0 - 200.0 %]	
18-93 Process PID Gain Scaled Output	
Range:	Function:
0.0 %* [-200.0 - 200.0 %]	

3.20 Parameters: 30-** Special Features

3.20.1 30-0* Wobble Function

The wobble option is to be installed in the adjustable frequency drive controlling the traverse drive. The wobble option is to be installed in the adjustable frequency drive controlling the traverse drive. The wobble option is to be installed in the adjustable frequency drive controlling the traverse drive. The wobble option is to be installed in the adjustable frequency drive controlling the traverse drive. The wobble option is to be installed in the adjustable frequency drive controlling the traverse drive. The wobble option is to be installed in the adjustable frequency drive controlling the traverse drive. The wobble option is to be installed in the adjustable frequency drive controlling the traverse drive. The wobble option is to be installed in the adjustable frequency drive controlling the traverse drive.

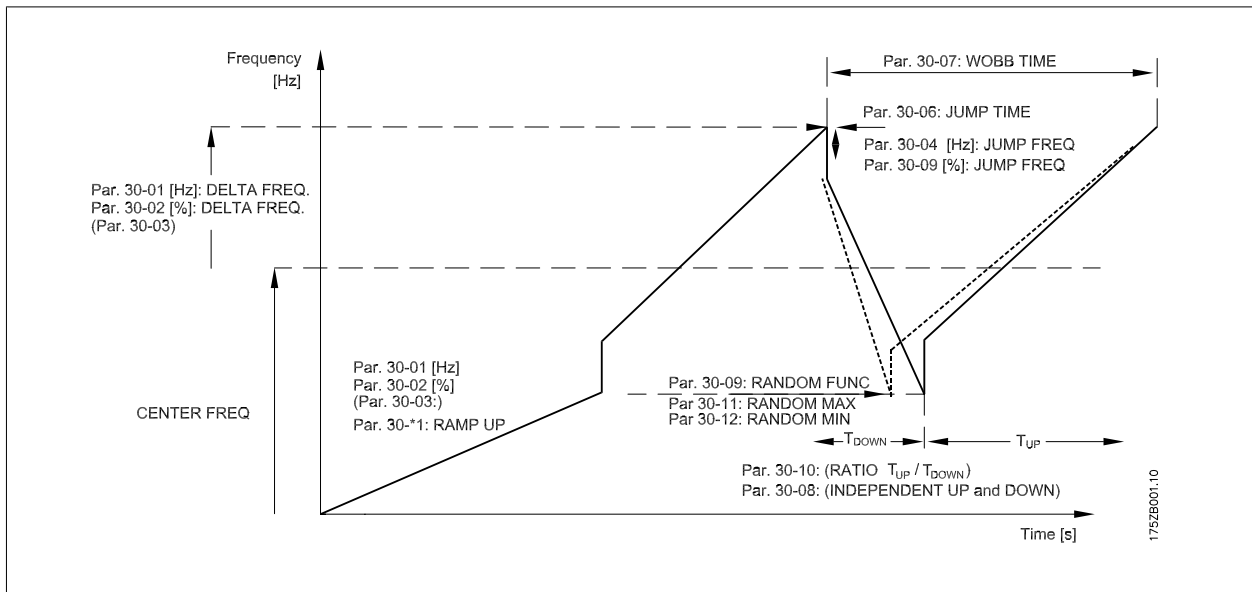

30-00 Wobble Mode

Option: **Function:**

The standard speed open-loop mode in par. 1-00 is extended with a wobble function. In this parameter, it is possible to select which method to be used for the wobbler. The frequency parameters can be set as absolute values (direct frequencies) or as relative values (percentage of other parameter). The wobble cycle time can be set as an absolute value or as independent up and down times. When using an absolute cycle time, the up and down times are configured through the wobble ratio.

- [0] * Abs. Freq., Abs. Time
- [1] Abs. Freq., Up/ Down Time
- [2] Rel. Freq., Abs. Time
- [3] Rel. Freq., Up/ Down Time

 This parameter can be set while running.

 **NOTE!**
The setting of "Center Frequency" takes place via the normal reference handling parameters, 3-1*

30-01 Wobble Delta Frequency [Hz]

Range: **Function:**

5.0 Hz* [0.0 - 25.0 Hz]

The delta frequency is determining the magnitude of the wobble frequency. The delta frequency is superimposed on the center frequency. Parameter 30-01 is selecting both the positive and negative delta frequency. The setting of parameter 30-01 must thus not be higher than the setting of the center frequency. The initial ramp up time from standstill until the wobble sequence is running is determined by parameters 3-1*.

30-02 Wobble Delta Frequency [%]

Range: **Function:**

25 %* [0 - 100 %]

The delta frequency can also be expressed as percentage of the center frequency and can thus be maximum 100%. The function is the same as for par. 30-01.

30-03 Wobble Delta Freq. Scaling Resource

Option: **Function:**

Select which drive input should be used to scale the delta frequency setting.

- [0] * No function
- [1] Analog input 53
- [2] Analog input 54
- [3] Frequency input 29 *FC 302 only*
- [4] Frequency input 33
- [7] Analog input X30/11
- [8] Analog input X30/12

30-04 Wobble Jump Frequency [Hz]**Range:**

0.0 Hz* [Application dependant]

Function:

The jump frequency is used to compensate for the inertia in the traverse system. If a jump in the output frequency is required in the top and in the bottom of the wobble sequence, the frequency jump is set in this parameter. If the traverse system has a very high inertia a high jump frequency may create a torque limit warning or trip (warning/alarm 12) or an overvoltage warning or trip (warning/alarm 7). This parameter can only be changed in stop mode

30-05 Wobble Jump Frequency [%]**Range:**

0 %* [0 - 100 %]

Function:

The jump frequency can also be expressed as percentage of the center frequency. The function is the same as for par. 30-04.

30-06 Wobble Jump Time**Range:**

Application dependent* [Application dependant]

Function:**30-07 Wobble Sequence Time****Range:**

10.0 s* [1.0 - 1000.0 s]

Function:

This parameter determines the wobble sequence period. This parameter can only be changed in stop mode.

Wobble time = $t_{up} + t_{down}$

30-08 Wobble Up/ Down Time**Range:**

5.0 s* [0.1 - 1000.0 s]

Function:

Defines the individual up and down times for each wobble cycle.

30-09 Wobble Random Function**Option:**

[0] * Off

[1] On

Function:**30-10 Wobble Ratio****Range:**

1.0* [Application dependant]

Function:

If the ratio 0.1 is selected: t_{down} is 10 times greater than t_{up} .

If the ratio 10 is selected: t_{up} is 10 times greater than t_{down} .

30-11 Wobble Random Ratio Max.**Range:**

10.0* [Application dependant]

Function:

Enter the maximum allowed wobble ratio.

30-12 Wobble Random Ratio Min.**Range:**

0.1* [Application dependant]

Function:

Enter the minimum allowed wobble ratio.

30-19 Wobble Delta Freq. Scaled**Range:**

0.0 Hz* [0.0 - 1000.0 Hz]

Function:

Readout parameter. View the actual wobble delta frequency after scaling has been applied.

3.20.2 30-8* Compatibility

30-80 d-axis Inductance (Ld)		
Range:	Function:	
Application dependent* [Application dependant]		
30-81 Brake Resistor (ohm)		
Range:	Function:	
Application dependent* [Application dependant]		
30-83 Speed PID Proportional Gain		
Range:	Function:	
Application dependent* [0.0000 - 1.0000]	Enter the speed controller proportional gain. Quick control is obtained at high amplification. However, if the amplification is too great, the process may become unstable.	
30-84 Process PID Proportional Gain		
Range:	Function:	
0.100* [0.000 - 10.000]	Enter the process controller proportional gain. Quick control is obtained at high amplification. However, if the amplification is too great, the process may become unstable.	

3

4 Parameter Lists

4.1 Parameter lists

FC Series

All = valid for FC 301 and FC 302 series

01 = valid for FC 301 only

02 = valid for FC 302 only

Changes during operation

“TRUE” means that the parameter can be changed while the adjustable frequency drive is in operation, and “FALSE” means that the adjustable frequency drive must be stopped before a change can be made.

4-Set-up

'All set-ups': the parameter can be set individually in each of the four set-ups, i. e., one single parameter can have four different data values.

'1 set-up': data value will be the same in all set-ups.

Conversion index

This number refers to a conversion figure used when writing or reading by means of an adjustable frequency drive.

Conv. index	100	67	6	5	4	3	2	1	0	-1	-2	-3	-4	-5	-6
Conv. factor	1	1/60	1000000	100000	10000	1000	100	10	1	0.1	0.01	0.001	0.0001	0.00001	0.000001

Data type	Description	Type
2	Integer 8	Int8
3	Integer 16	Int16
4	Integer 32	Int32
5	Unsigned 8	UInt8
6	Unsigned 16	UInt16
7	Unsigned 32	UInt32
9	Visible String	VisStr
33	Normalized value 2 bytes	N2
35	Bit sequence of 16 Boolean variables	V2
54	Time difference w/o date	TimD

4.1.1 0-** Operation/Display

Par. No. #	Parameter description	Default value	4-set-up	FC 302 only	Change during operation	Conversion index	Type
0-0* Basic Settings							
0-01	Language	[0] English	1 set-up		TRUE	-	Uint8
0-02	Motor Speed Unit	[0] RPM	2 set-ups		FALSE	-	Uint8
0-03	Regional Settings	[0] International	2 set-ups		FALSE	-	Uint8
0-04	Operating State at Power-up (Hand)	[1] Forced stop, ref=old	All set-ups		TRUE	-	Uint8
0-1* Set-up Operations							
0-10	Active Set-up	[1] Set-up 1	1 set-up		TRUE	-	Uint8
0-11	Edit Set-up	[1] Set-up 1	All set-ups		TRUE	-	Uint8
0-12	This Set-up Linked to	[0] Not linked	All set-ups		FALSE	-	Uint8
0-13	Readout: Linked Set-ups	0 N/A	All set-ups		FALSE	0	Uint16
0-14	Readout: Edit Set-ups / Channel	0 N/A	All set-ups		TRUE	0	Int32
0-2* LCP Display							
0-20	Display Line 1.1 Small	1617	All set-ups		TRUE	-	Uint16
0-21	Display Line 1.2 Small	1614	All set-ups		TRUE	-	Uint16
0-22	Display Line 1.3 Small	1610	All set-ups		TRUE	-	Uint16
0-23	Display Line 2 Large	1613	All set-ups		TRUE	-	Uint16
0-24	Display Line 3 Large	1602	All set-ups		TRUE	-	Uint16
0-25	My Personal Menu	ExpressionLimit	1 set-up		TRUE	0	Uint16
0-3* LCP Cust. Readout							
0-30	Unit for User-defined Readout	[0] None	All set-ups		TRUE	-	Uint8
0-31	Min Value of User-defined Readout	0.00 CustomReadoutUnit	All set-ups		TRUE	-2	Int32
0-32	Max Value of User-defined Readout	100.00 CustomReadoutUnit	All set-ups		TRUE	-2	Int32
0-4* LCP Keypad							
0-40	[Hand on] Key on LCP	null	All set-ups		TRUE	-	Uint8
0-41	[Off] Key on LCP	null	All set-ups		TRUE	-	Uint8
0-42	[Auto on] Key on LCP	null	All set-ups		TRUE	-	Uint8
0-43	[Reset] Key on LCP	null	All set-ups		TRUE	-	Uint8
0-5* Copy/Save							
0-50	LCP Copy	[0] No copy	All set-ups		FALSE	-	Uint8
0-51	Set-up Copy	[0] No copy	All set-ups		FALSE	-	Uint8
0-6* Password							
0-60	Main Menu Password	100 N/A	1 set-up		TRUE	0	Int16
0-61	Access to Main Menu w/o Password	[0] Full access	1 set-up		TRUE	-	Uint8
0-65	Quick Menu Password	200 N/A	1 set-up		TRUE	0	Int16
0-66	Access to Quick Menu w/o Password	[0] Full access	1 set-up		TRUE	-	Uint8
0-67	Bus Password Access	0 N/A	All set-ups		TRUE	0	Uint16

4.1.2 1- Load/Motor**

Par. No. #	Parameter description	Default value	4-set-up	FC 302 only	Change during operation	Conversion index	Type
1-0* General Settings							
1-00	Configuration Mode	null	All set-ups		TRUE	-	Uint8
1-01	Motor Control Principle	null	All set-ups		FALSE	-	Uint8
1-02	Flux Motor Feedback Source	[1] 24V encoder	All set-ups	x	FALSE	-	Uint8
1-03	Torque Characteristics	[0] Constant torque	All set-ups		TRUE	-	Uint8
1-04	Overload Mode	[0] High torque	All set-ups		FALSE	-	Uint8
1-05	Local Mode Configuration	[2] As mode par 1-00	All set-ups		TRUE	-	Uint8
1-1* Motor Selection							
1-10	Motor Construction	[0] Asynchron	All set-ups		FALSE	-	Uint8
1-2* Motor Data							
1-20	Motor Power [kW]	ExpressionLimit	All set-ups		FALSE	1	Uint32
1-21	Motor Power [HP]	ExpressionLimit	All set-ups		FALSE	-2	Uint32
1-22	Motor Voltage	ExpressionLimit	All set-ups		FALSE	0	Uint16
1-23	Motor Frequency	ExpressionLimit	All set-ups		FALSE	0	Uint16
1-24	Motor Current	ExpressionLimit	All set-ups		FALSE	-2	Uint32
1-25	Motor Nominal Speed	ExpressionLimit	All set-ups		FALSE	67	Uint16
1-26	Motor Cont. Rated Torque	ExpressionLimit	All set-ups		FALSE	-1	Uint32
1-29	Automatic Motor Adaptation (AMA)	[0] Off	All set-ups		FALSE	-	Uint8
1-3* Addl. Motor Data							
1-30	Stator Resistance (Rs)	ExpressionLimit	All set-ups		FALSE	-4	Uint32
1-31	Rotor Resistance (Rr)	ExpressionLimit	All set-ups		FALSE	-4	Uint32
1-33	Stator Leakage Reactance (X1)	ExpressionLimit	All set-ups		FALSE	-4	Uint32
1-34	Rotor Leakage Reactance (X2)	ExpressionLimit	All set-ups		FALSE	-4	Uint32
1-35	Main Reactance (Xh)	ExpressionLimit	All set-ups		FALSE	-4	Uint32
1-36	Iron Loss Resistance (Rfe)	ExpressionLimit	All set-ups		FALSE	-3	Uint32
1-37	d-axis Inductance (Ld)	ExpressionLimit	All set-ups	x	FALSE	-4	Int32
1-39	Motor Poles	ExpressionLimit	All set-ups		FALSE	0	Uint8
1-40	Back EMF at 1000 RPM	ExpressionLimit	All set-ups	x	FALSE	0	Uint16
1-41	Motor Angle Offset	0 N/A	All set-ups		FALSE	0	Int16
1-5* Load-Indep. Setting							
1-50	Motor Magnetization at Zero Speed	100 %	All set-ups		TRUE	0	Uint16
1-51	Min Speed Normal Magnetizing [RPM]	ExpressionLimit	All set-ups		TRUE	67	Uint16
1-52	Min Speed Normal Magnetizing [Hz]	ExpressionLimit	All set-ups		TRUE	-1	Uint16
1-53	Model Shift Frequency	ExpressionLimit	All set-ups	x	FALSE	-1	Uint16
1-55	U/f Characteristic - U	ExpressionLimit	All set-ups		TRUE	-1	Uint16
1-56	U/f Characteristic - F	ExpressionLimit	All set-ups		TRUE	-1	Uint16
1-6* Load-Depend. Settg.							
1-60	Low Speed Load Compensation	100 %	All set-ups		TRUE	0	Int16
1-61	High Speed Load Compensation	100 %	All set-ups		TRUE	0	Int16
1-62	Slip Compensation	ExpressionLimit	All set-ups		TRUE	0	Int16
1-63	Slip Compensation Time Constant	ExpressionLimit	All set-ups		TRUE	-2	Uint16
1-64	Resonance Dampening	100 %	All set-ups		TRUE	0	Uint16
1-65	Resonance Dampening Time Constant	5 ms	All set-ups		TRUE	-3	Uint8
1-66	Min. Current at Low Speed	100 %	All set-ups	x	TRUE	0	Uint8
1-67	Load Type	[0] Passive load	All set-ups	x	TRUE	-	Uint8
1-68	Minimum Inertia	ExpressionLimit	All set-ups	x	FALSE	-4	Uint32
1-69	Maximum Inertia	ExpressionLimit	All set-ups	x	FALSE	-4	Uint32
1-7* Start Adjustments							
1-71	Start Delay	0.0 s	All set-ups		TRUE	-1	Uint8
1-72	Start Function	[2] Coast/delay time	All set-ups		TRUE	-	Uint8
1-73	Flying Start	[0] Disabled	All set-ups		FALSE	-	Uint8
1-74	Start Speed [RPM]	ExpressionLimit	All set-ups		TRUE	67	Uint16
1-75	Start Speed [Hz]	ExpressionLimit	All set-ups		TRUE	-1	Uint16
1-76	Start Current	0.00 A	All set-ups		TRUE	-2	Uint32
1-8* Stop Adjustments							
1-80	Function at Stop	[0] Coast	All set-ups		TRUE	-	Uint8
1-81	Min Speed for Function at Stop [RPM]	ExpressionLimit	All set-ups		TRUE	67	Uint16
1-82	Min Speed for Function at Stop [Hz]	ExpressionLimit	All set-ups		TRUE	-1	Uint16
1-83	Precise Stop Function	[0] Precise ramp stop	All set-ups		FALSE	-	Uint8
1-84	Precise Stop Counter Value	100000 N/A	All set-ups		TRUE	0	Uint32
1-85	Precise Stop Speed Compensation Delay	10 ms	All set-ups		TRUE	-3	Uint8
1-9* Motor Temperature							
1-90	Motor Thermal Protection	[0] No protection	All set-ups		TRUE	-	Uint8
1-91	Motor External Fan	[0] No	All set-ups		TRUE	-	Uint16
1-93	Thermistor Resource	[0] None	All set-ups		TRUE	-	Uint8
1-95	KTY Sensor Type	[0] KTY Sensor 1	All set-ups	x	TRUE	-	Uint8
1-96	KTY Thermistor Resource	[0] None	All set-ups	x	TRUE	-	Uint8
1-97	KTY Threshold level	80 °C	1 set-up	x	TRUE	100	Int16

4.1.3 2-** Brakes

Par. No. #	Parameter description	Default value	4-set-up	FC 302 only	Change during operation	Conversion index	Type
2-0* DC Brake							
2-00	DC Hold Current	50 %	All set-ups		TRUE	0	Uint8
2-01	DC Brake Current	50 %	All set-ups		TRUE	0	Uint16
2-02	DC Braking Time	10.0 s	All set-ups		TRUE	-1	Uint16
2-03	DC Brake Cut-in Speed [RPM]	ExpressionLimit	All set-ups		TRUE	67	Uint16
2-04	DC Brake Cut-in Speed [Hz]	ExpressionLimit	All set-ups		TRUE	-1	Uint16
2-05	Maximum Reference	MaxReference (P303)	All set-ups		TRUE	-3	Int32
2-1* Brake Energy Funct.							
2-10	Brake Function	null	All set-ups		TRUE	-	Uint8
2-11	Brake Resistor (ohm)	ExpressionLimit	All set-ups		TRUE	0	Uint16
2-12	Brake Power Limit (kW)	ExpressionLimit	All set-ups		TRUE	0	Uint32
2-13	Brake Power Monitoring	[0] Off	All set-ups		TRUE	-	Uint8
2-15	Brake Check	[0] Off	All set-ups		TRUE	-	Uint8
2-16	AC Brake Max. Current	100.0 %	All set-ups		TRUE	-1	Uint32
2-17	Over-voltage Control	[0] Disabled	All set-ups		TRUE	-	Uint8
2-18	Brake Check Condition	[0] At Power Up	All set-ups		TRUE	-	Uint8
2-2* Mechanical Brake							
2-20	Release Brake Current	I _{maxVLT} (P1637)	All set-ups		TRUE	-2	Uint32
2-21	Activate Brake Speed [RPM]	ExpressionLimit	All set-ups		TRUE	67	Uint16
2-22	Activate Brake Speed [Hz]	ExpressionLimit	All set-ups		TRUE	-1	Uint16
2-23	Activate Brake Delay	0.0 s	All set-ups		TRUE	-1	Uint8
2-24	Stop Delay	0.0 s	All set-ups		TRUE	-1	Uint8
2-25	Brake Release Time	0.20 s	All set-ups		TRUE	-2	Uint16
2-26	Torque Ref	0.00 %	All set-ups		TRUE	-2	Int16
2-27	Torque Ramp Time	0.2 s	All set-ups		TRUE	-1	Uint8
2-28	Gain Boost Factor	1.00 N/A	All set-ups		TRUE	-2	Uint16

4.1.4 3-** Reference / Ramps

Par. No. #	Parameter description	Default value	4-set-up	FC 302 only	Change during operation	Conversion index	Type
3-0* Reference Limits							
3-00	Reference Range	null	All set-ups		TRUE	-	Uint8
3-01	Reference/Feedback Unit	null	All set-ups		TRUE	-	Uint8
3-02	Minimum Reference	ExpressionLimit	All set-ups		TRUE	-3	Int32
3-03	Maximum Reference	ExpressionLimit	All set-ups		TRUE	-3	Int32
3-04	Reference Function	[0] Sum	All set-ups		TRUE	-	Uint8
3-1* References							
3-10	Preset Reference	0.00 %	All set-ups		TRUE	-2	Int16
3-11	Jog Speed [Hz]	ExpressionLimit	All set-ups		TRUE	-1	Uint16
3-12	Catch up/slow-down Value	0.00 %	All set-ups		TRUE	-2	Int16
3-13	Reference Site	[0] Linked to Hand / Auto	All set-ups		TRUE	-	Uint8
3-14	Preset Relative Reference	0.00 %	All set-ups		TRUE	-2	Int32
3-15	Reference Resource 1	null	All set-ups		TRUE	-	Uint8
3-16	Reference Resource 2	null	All set-ups		TRUE	-	Uint8
3-17	Reference Resource 3	null	All set-ups		TRUE	-	Uint8
3-18	Relative Scaling Reference Resource	[0] No function	All set-ups		TRUE	-	Uint8
3-19	Jog Speed [RPM]	ExpressionLimit	All set-ups		TRUE	67	Uint16
3-4* Ramp 1							
3-40	Ramp 1 Type	[0] Linear	All set-ups		TRUE	-	Uint8
3-41	Ramp 1 Ramp-up Time	ExpressionLimit	All set-ups		TRUE	-2	Uint32
3-42	Ramp 1 Ramp-down Time	ExpressionLimit	All set-ups		TRUE	-2	Uint32
3-45	Ramp 1 S-ramp Ratio at Accel. Start	50 %	All set-ups		TRUE	0	Uint8
3-46	Ramp 1 S-ramp Ratio at Accel. End	50 %	All set-ups		TRUE	0	Uint8
3-47	Ramp 1 S-ramp Ratio at Decel. Start	50 %	All set-ups		TRUE	0	Uint8
3-48	Ramp 1 S-ramp Ratio at Decel. End	50 %	All set-ups		TRUE	0	Uint8
3-5* Ramp 2							
3-50	Ramp 2 Type	[0] Linear	All set-ups		TRUE	-	Uint8
3-51	Ramp 2 Ramp-up Time	ExpressionLimit	All set-ups		TRUE	-2	Uint32
3-52	Ramp 2 Ramp-down Time	ExpressionLimit	All set-ups		TRUE	-2	Uint32
3-55	Ramp 2 S-ramp Ratio at Accel. Start	50 %	All set-ups		TRUE	0	Uint8
3-56	Ramp 2 S-ramp Ratio at Accel. End	50 %	All set-ups		TRUE	0	Uint8
3-57	Ramp 2 S-ramp Ratio at Decel. Start	50 %	All set-ups		TRUE	0	Uint8
3-58	Ramp 2 S-ramp Ratio at Decel. End	50 %	All set-ups		TRUE	0	Uint8
3-6* Ramp 3							
3-60	Ramp 3 Type	[0] Linear	All set-ups		TRUE	-	Uint8
3-61	Ramp 3 Ramp-up Time	ExpressionLimit	All set-ups		TRUE	-2	Uint32
3-62	Ramp 3 Ramp-down Time	ExpressionLimit	All set-ups		TRUE	-2	Uint32
3-65	Ramp 3 S-ramp Ratio at Accel. Start	50 %	All set-ups		TRUE	0	Uint8
3-66	Ramp 3 S-ramp Ratio at Accel. End	50 %	All set-ups		TRUE	0	Uint8
3-67	Ramp 3 S-ramp Ratio at Decel. Start	50 %	All set-ups		TRUE	0	Uint8
3-68	Ramp 3 S-ramp Ratio at Decel. End	50 %	All set-ups		TRUE	0	Uint8
3-7* Ramp 4							
3-70	Ramp 4 Type	[0] Linear	All set-ups		TRUE	-	Uint8
3-71	Ramp 4 Ramp-up Time	ExpressionLimit	All set-ups		TRUE	-2	Uint32
3-72	Ramp 4 Ramp-down Time	ExpressionLimit	All set-ups		TRUE	-2	Uint32
3-75	Ramp 4 S-ramp Ratio at Accel. Start	50 %	All set-ups		TRUE	0	Uint8
3-76	Ramp 4 S-ramp Ratio at Accel. End	50 %	All set-ups		TRUE	0	Uint8
3-77	Ramp 4 S-ramp Ratio at Decel. Start	50 %	All set-ups		TRUE	0	Uint8
3-78	Ramp 4 S-ramp Ratio at Decel. End	50 %	All set-ups		TRUE	0	Uint8
3-8* Other Ramps							
3-80	Jog Ramp Time	ExpressionLimit	All set-ups		TRUE	-2	Uint32
3-81	Quick Stop Ramp Time	ExpressionLimit	2 set-ups		TRUE	-2	Uint32
3-82	Quick Stop Ramp Type	[0] Linear	All set-ups		TRUE	-	Uint8
3-83	Quick Stop S-ramp Ratio at Decel. Start	50 %	All set-ups		TRUE	0	Uint8
3-84	Quick Stop S-ramp Ratio at Decel. End	50 %	All set-ups		TRUE	0	Uint8
3-9* Digital Pot. meter							
3-90	Step Size	0.10 %	All set-ups		TRUE	-2	Uint16
3-91	Ramp Time	1.00 s	All set-ups		TRUE	-2	Uint32
3-92	Power Restore	[0] Off	All set-ups		TRUE	-	Uint8
3-93	Maximum Limit	100 %	All set-ups		TRUE	0	Int16
3-94	Minimum Limit	-100 %	All set-ups		TRUE	0	Int16
3-95	Ramp Delay	ExpressionLimit	All set-ups		TRUE	-3	TimD

4.1.5 4-** Limits / Warnings

Par. No. #	Parameter description	Default value	4-set-up	FC 302 only	Change during operation	Conversion index	Type
4-1* Motor Limits							
4-10	Motor Speed Direction	null	All set-ups		FALSE	-	Uint8
4-11	Motor Speed Low Limit [RPM]	ExpressionLimit	All set-ups		TRUE	67	Uint16
4-12	Motor Speed Low Limit [Hz]	ExpressionLimit	All set-ups		TRUE	-1	Uint16
4-13	Motor Speed High Limit [RPM]	ExpressionLimit	All set-ups		TRUE	67	Uint16
4-14	Motor Speed High Limit [Hz]	ExpressionLimit	All set-ups		TRUE	-1	Uint16
4-16	Torque Limit Motor Mode	ExpressionLimit	All set-ups		TRUE	-1	Uint16
4-17	Torque Limit Generator Mode	100.0 %	All set-ups		TRUE	-1	Uint16
4-18	Current Limit	ExpressionLimit	All set-ups		TRUE	-1	Uint32
4-19	Max Output Frequency	132.0 Hz	All set-ups		FALSE	-1	Uint16
4-2* Limit Factors							
4-20	Torque Limit Factor Source	[0] No function	All set-ups		TRUE	-	Uint8
4-21	Speed Limit Factor Source	[0] No function	All set-ups		TRUE	-	Uint8
4-3* Motor Fb Monitor							
4-30	Motor Feedback Loss Function	[2] Trip	All set-ups		TRUE	-	Uint8
4-31	Motor Feedback Speed Error	300 RPM	All set-ups		TRUE	67	Uint16
4-32	Motor Feedback Loss Timeout	0.05 s	All set-ups		TRUE	-2	Uint16
4-34	Tracking Error Function	[0] Disable	All set-ups		TRUE	-	Uint8
4-35	Tracking Error	10 RPM	All set-ups		TRUE	67	Uint16
4-36	Tracking Error Timeout	1.00 s	All set-ups		TRUE	-2	Uint16
4-37	Tracking Error Ramping	100 RPM	All set-ups		TRUE	67	Uint16
4-38	Tracking Error Ramping Timeout	1.00 s	All set-ups		TRUE	-2	Uint16
4-39	Tracking Error After Ramping Timeout	5.00 s	All set-ups		TRUE	-2	Uint16
4-5* Adj. Warnings							
4-50	Warning Current Low	0.00 A	All set-ups		TRUE	-2	Uint32
4-51	Warning Current High	ImaxVLT (P1637)	All set-ups		TRUE	-2	Uint32
4-52	Warning Speed Low	0 RPM	All set-ups		TRUE	67	Uint16
4-53	Warning Speed High	outputSpeedHighLimit (P413)	All set-ups		TRUE	67	Uint16
4-54	Warning Reference Low	-999999.999 N/A	All set-ups		TRUE	-3	Int32
4-55	Warning Reference High	999999.999 N/A	All set-ups		TRUE	-3	Int32
4-56	Warning Feedback Low	-999999.999 Reference-FeedbackUnit	All set-ups		TRUE	-3	Int32
4-57	Warning Feedback High	999999.999 ReferenceFeed-backUnit	All set-ups		TRUE	-3	Int32
4-58	Missing Motor Phase Function	null	All set-ups		TRUE	-	Uint8
4-6* Speed Bypass							
4-60	Bypass Speed From [RPM]	ExpressionLimit	All set-ups		TRUE	67	Uint16
4-61	Bypass Speed From [Hz]	ExpressionLimit	All set-ups		TRUE	-1	Uint16
4-62	Bypass Speed to [RPM]	ExpressionLimit	All set-ups		TRUE	67	Uint16
4-63	Bypass Speed To [Hz]	ExpressionLimit	All set-ups		TRUE	-1	Uint16

4.1.6 5-** Digital In/Out

Par. No. #	Parameter description	Default value	4-set-up	FC 302 only	Change during operation	Conversion index	Type
5-0* Digital I/O mode							
5-00	Digital I/O Mode	[0] PNP	All set-ups		FALSE	-	Uint8
5-01	Terminal 27 Mode	[0] Input	All set-ups		TRUE	-	Uint8
5-02	Terminal 29 Mode	[0] Input	All set-ups	x	TRUE	-	Uint8
5-1* Digital Inputs							
5-10	Terminal 18 Digital Input	null	All set-ups		TRUE	-	Uint8
5-11	Terminal 19 Digital Input	null	All set-ups		TRUE	-	Uint8
5-12	Terminal 27 Digital Input	null	All set-ups		TRUE	-	Uint8
5-13	Terminal 29 Digital Input	null	All set-ups	x	TRUE	-	Uint8
5-14	Terminal 32 Digital Input	null	All set-ups		TRUE	-	Uint8
5-15	Terminal 33 Digital Input	null	All set-ups		TRUE	-	Uint8
5-16	Terminal X30/2 Digital Input	null	All set-ups		TRUE	-	Uint8
5-17	Terminal X30/3 Digital Input	null	All set-ups		TRUE	-	Uint8
5-18	Terminal X30/4 Digital Input	null	All set-ups		TRUE	-	Uint8
5-19	Terminal 37 Safe Stop	[1] Safe Stop Alarm	1 set-up		TRUE	-	Uint8
5-20	Terminal X46/1 Digital Input	[0] No operation	All set-ups		TRUE	-	Uint8
5-21	Terminal X46/3 Digital Input	[0] No operation	All set-ups		TRUE	-	Uint8
5-22	Terminal X46/5 Digital Input	[0] No operation	All set-ups		TRUE	-	Uint8
5-23	Terminal X46/7 Digital Input	[0] No operation	All set-ups		TRUE	-	Uint8
5-24	Terminal X46/9 Digital Input	[0] No operation	All set-ups		TRUE	-	Uint8
5-25	Terminal X46/11 Digital Input	[0] No operation	All set-ups		TRUE	-	Uint8
5-26	Terminal X46/13 Digital Input	[0] No operation	All set-ups		TRUE	-	Uint8
5-3* Digital Outputs							
5-30	Terminal 27 Digital Output	null	All set-ups		TRUE	-	Uint8
5-31	Terminal 29 digital Output	null	All set-ups	x	TRUE	-	Uint8
5-32	Term X30/6 Digi Out (MCB 101)	null	All set-ups		TRUE	-	Uint8
5-33	Term X30/7 Digi Out (MCB 101)	null	All set-ups		TRUE	-	Uint8
5-4* Relays							
5-40	Function Relay	null	All set-ups		TRUE	-	Uint8
5-41	On Delay, Relay	0.01 s	All set-ups		TRUE	-2	Uint16
5-42	Off Delay, Relay	0.01 s	All set-ups		TRUE	-2	Uint16
5-5* Pulse Input							
5-50	Term. 29 Low Frequency	100 Hz	All set-ups	x	TRUE	0	Uint32
5-51	Term. 29 High Frequency	100 Hz	All set-ups	x	TRUE	0	Uint32
5-52	Term. 29 Low Ref./Feedb. Value	0.000 ReferenceFeedbackUnit	All set-ups	x	TRUE	-3	Int32
5-53	Term. 29 High Ref./Feedb. Value	ExpressionLimit	All set-ups	x	TRUE	-3	Int32
5-54	Pulse Filter Time Constant #29	100 ms	All set-ups	x	FALSE	-3	Uint16
5-55	Term. 33 Low Frequency	100 Hz	All set-ups		TRUE	0	Uint32
5-56	Term. 33 High Frequency	100 Hz	All set-ups		TRUE	0	Uint32
5-57	Term. 33 Low Ref./Feedb. Value	0.000 ReferenceFeedbackUnit	All set-ups		TRUE	-3	Int32
5-58	Term. 33 High Ref./Feedb. Value	ExpressionLimit	All set-ups		TRUE	-3	Int32
5-59	Pulse Filter Time Constant #33	100 ms	All set-ups		FALSE	-3	Uint16
5-6* Pulse Output							
5-60	Terminal 27 Pulse Output Variable	null	All set-ups		TRUE	-	Uint8
5-62	Pulse Output Max Freq #27	ExpressionLimit	All set-ups		TRUE	0	Uint32
5-63	Terminal 29 Pulse Output Variable	null	All set-ups	x	TRUE	-	Uint8
5-65	Pulse Output Max Freq #29	ExpressionLimit	All set-ups	x	TRUE	0	Uint32
5-66	Terminal X30/6 Pulse Output Variable	null	All set-ups		TRUE	-	Uint8
5-68	Pulse Output Max Freq #X30/6	ExpressionLimit	All set-ups		TRUE	0	Uint32
5-7* 24V Encoder Input							
5-70	Term 32/33 Pulses per Revolution	1024 N/A	All set-ups		FALSE	0	Uint16
5-71	Term 32/33 Encoder Direction	[0] Clockwise	All set-ups		FALSE	-	Uint8
5-9* Bus Controlled							
5-90	Digital & Relay Bus Control	0 N/A	All set-ups		TRUE	0	Uint32
5-93	Pulse Out #27 Bus Control	0.00 %	All set-ups		TRUE	-2	N2
5-94	Pulse Out #27 Timeout Preset	0.00 %	1 set-up		TRUE	-2	Uint16
5-95	Pulse Out #29 Bus Control	0.00 %	All set-ups	x	TRUE	-2	N2
5-96	Pulse Out #29 Timeout Preset	0.00 %	1 set-up	x	TRUE	-2	Uint16
5-97	Pulse Out #X30/6 Bus Control	0.00 %	All set-ups		TRUE	-2	N2
5-98	Pulse Out #X30/6 Timeout Preset	0.00 %	1 set-up		TRUE	-2	Uint16

4.1.7 6-** Analog In/Out

Par. No. #	Parameter description	Default value	4-set-up	FC 302 only	Change during operation	Conversion index	Type
6-0* Analog I/O Mode							
6-00	Live Zero Timeout Time	10 s	All set-ups		TRUE	0	Uint8
6-01	Live Zero Timeout Function	[0] Off	All set-ups		TRUE	-	Uint8
6-1* Analog Input 1							
6-10	Terminal 53 Low Voltage	0.07 V	All set-ups		TRUE	-2	Int16
6-11	Terminal 53 High Voltage	10.00 V	All set-ups		TRUE	-2	Int16
6-12	Terminal 53 Low Current	0.14 mA	All set-ups		TRUE	-5	Int16
6-13	Terminal 53 High Current	20.00 mA	All set-ups		TRUE	-5	Int16
6-14	Terminal 53 Low Ref./Feedb. Value	0 ReferenceFeedbackUnit	All set-ups		TRUE	-3	Int32
6-15	Terminal 53 High Ref./Feedb. Value	ExpressionLimit	All set-ups		TRUE	-3	Int32
6-16	Terminal 53 Filter Time Constant	0.001 s	All set-ups		TRUE	-3	Uint16
6-2* Analog Input 2							
6-20	Terminal 54 Low Voltage	0.07 V	All set-ups		TRUE	-2	Int16
6-21	Terminal 54 High Voltage	10.00 V	All set-ups		TRUE	-2	Int16
6-22	Terminal 54 Low Current	0.14 mA	All set-ups		TRUE	-5	Int16
6-23	Terminal 54 High Current	20.00 mA	All set-ups		TRUE	-5	Int16
6-24	Terminal 54 Low Ref./Feedb. Value	0 ReferenceFeedbackUnit	All set-ups		TRUE	-3	Int32
6-25	Terminal 54 High Ref./Feedb. Value	ExpressionLimit	All set-ups		TRUE	-3	Int32
6-26	Terminal 54 Filter Time Constant	0.001 s	All set-ups		TRUE	-3	Uint16
6-3* Analog Input 53							
6-30	Terminal X30/11 Low Voltage	0.07 V	All set-ups		TRUE	-2	Int16
6-31	Terminal X30/11 High Voltage	10.00 V	All set-ups		TRUE	-2	Int16
6-34	Term. X30/11 Low Ref./Feedb. Value	0 ReferenceFeedbackUnit	All set-ups		TRUE	-3	Int32
6-35	Term. X30/11 High Ref./Feedb. Value	ExpressionLimit	All set-ups		TRUE	-3	Int32
6-36	Term. X30/11 Filter Time Constant	0.001 s	All set-ups		TRUE	-3	Uint16
6-4* Analog Input 4							
6-40	Terminal X30/12 Low Voltage	0.07 V	All set-ups		TRUE	-2	Int16
6-41	Terminal X30/12 High Voltage	10.00 V	All set-ups		TRUE	-2	Int16
6-44	Term. X30/12 Low Ref./Feedb. Value	0 ReferenceFeedbackUnit	All set-ups		TRUE	-3	Int32
6-45	Term. X30/12 High Ref./Feedb. Value	ExpressionLimit	All set-ups		TRUE	-3	Int32
6-46	Term. X30/12 Filter Time Constant	0.001 s	All set-ups		TRUE	-3	Uint16
6-5* Analog Output 1							
6-50	Terminal 42 Output	null	All set-ups		TRUE	-	Uint8
6-51	Terminal 42 Output Min Scale	0.00 %	All set-ups		TRUE	-2	Int16
6-52	Terminal 42 Output Max Scale	100.00 %	All set-ups		TRUE	-2	Int16
6-53	Terminal 42 Output Bus Control	0.00 %	All set-ups		TRUE	-2	N2
6-54	Terminal 42 Output Timeout Preset	0.00 %	1 set-up		TRUE	-2	Uint16
6-55	Terminal 42 Output Filter	[0] Off	1 set-up		TRUE	-	Uint8
6-6* Analog Output 2							
6-60	Terminal X30/8 Output	null	All set-ups		TRUE	-	Uint8
6-61	Terminal X30/8 Min. Scale	0.00 %	All set-ups		TRUE	-2	Int16
6-62	Terminal X30/8 Max. Scale	100.00 %	All set-ups		TRUE	-2	Int16
6-63	Terminal X30/8 Bus Control	0.00 %	All set-ups		TRUE	-2	N2
6-64	Terminal X30/8 Output Timeout Preset	0.00 %	1 set-up		TRUE	-2	Uint16
6-7* Analog Output 3							
6-70	Terminal X45/1 Output	null	All set-ups		TRUE	-	Uint8
6-71	Terminal X45/1 Min. Scale	0.00 %	All set-ups		TRUE	-2	Int16
6-72	Terminal X45/1 Max. Scale	100.00 %	All set-ups		TRUE	-2	Int16
6-73	Terminal X45/1 Bus Control	0.00 %	All set-ups		TRUE	-2	N2
6-74	Terminal X45/1 Output Timeout Preset	0.00 %	1 set-up		TRUE	-2	Uint16
6-8* Analog Output 4							
6-80	Terminal X45/3 Output	null	All set-ups		TRUE	-	Uint8
6-81	Terminal X45/3 Min. Scale	0.00 %	All set-ups		TRUE	-2	Int16
6-82	Terminal X45/3 Max. Scale	100.00 %	All set-ups		TRUE	-2	Int16
6-83	Terminal X45/3 Bus Control	0.00 %	All set-ups		TRUE	-2	N2
6-84	Terminal X45/3 Output Timeout Preset	0.00 %	1 set-up		TRUE	-2	Uint16

4.1.8 7- Controllers**

Par. No. #	Parameter description	Default value	4-set-up	FC 302 only	Change during operation	Conversion index	Type
7-0* Speed PID Ctrl.							
7-00	Speed PID Feedback Source	null	All set-ups		FALSE	-	Uint8
7-02	Speed PID Proportional Gain	ExpressionLimit	All set-ups		TRUE	-3	Uint16
7-03	Speed PID Integral Time	ExpressionLimit	All set-ups		TRUE	-4	Uint32
7-04	Speed PID Differentiation Time	ExpressionLimit	All set-ups		TRUE	-4	Uint16
7-05	Speed PID Diff. Gain Limit	5.0 N/A	All set-ups		TRUE	-1	Uint16
7-06	Speed PID Lowpass Filter Time	10.0 ms	All set-ups		TRUE	-4	Uint16
7-07	Speed PID Feedback Gear Ratio	1.0000 N/A	All set-ups		FALSE	-4	Uint32
7-08	Speed PID Feed Forward Factor	0 %	All set-ups		FALSE	0	Uint16
7-1* Torque PI Ctrl.							
7-12	Torque PI Proportional Gain	100 %	All set-ups		TRUE	0	Uint16
7-13	Torque PI Integration Time	0.020 s	All set-ups		TRUE	-3	Uint16
7-2* Process Ctrl. Feedb							
7-20	Process CL Feedback 1 Resource	[0] No function	All set-ups		TRUE	-	Uint8
7-22	Process CL Feedback 2 Resource	[0] No function	All set-ups		TRUE	-	Uint8
7-3* Process PID Ctrl.							
7-30	Process PID Normal/Inverse Control	[0] Normal	All set-ups		TRUE	-	Uint8
7-31	Process PID Anti Windup	[1] On	All set-ups		TRUE	-	Uint8
7-32	Process PID Controller Start Value	0 RPM	All set-ups		TRUE	67	Uint16
7-33	Process PID Proportional Gain	0.01 N/A	All set-ups		TRUE	-2	Uint16
7-34	Process PID Integral Time	10000.00 s	All set-ups		TRUE	-2	Uint32
7-35	Process PID Differentiation Time	0.00 s	All set-ups		TRUE	-2	Uint16
7-36	Process PID Differentiation Gain Limit	5.0 N/A	All set-ups		TRUE	-1	Uint16
7-38	Process PID Feed Forward Factor	0 %	All set-ups		TRUE	0	Uint16
7-39	On Reference Bandwidth	5 %	All set-ups		TRUE	0	Uint8
7-4* Adv. Process PID I							
7-40	Process PID I-part Reset	[0] No	All set-ups		TRUE	-	Uint8
7-41	Process PID Output Neg. Clamp	-100 %	All set-ups		TRUE	0	Int16
7-42	Process PID Output Pos. Clamp	100 %	All set-ups		TRUE	0	Int16
7-43	Process PID Gain Scale at Min. Ref.	100 %	All set-ups		TRUE	0	Int16
7-44	Process PID Gain Scale at Max. Ref.	100 %	All set-ups		TRUE	0	Int16
7-45	Process PID Feed Fwd Resource	[0] No function	All set-ups		TRUE	-	Uint8
7-46	Process PID Feed Fwd Normal/ Inv. Ctrl.	[0] Normal	All set-ups		TRUE	-	Uint8
7-49	Process PID Output Normal/ Inv. Ctrl.	[0] Normal	All set-ups		TRUE	-	Uint8
7-5* Adv. Process PID II							
7-50	Process PID Extended PID	[1] Enabled	All set-ups		TRUE	-	Uint8
7-51	Process PID Feed Fwd Gain	1.00 N/A	All set-ups		TRUE	-2	Uint16
7-52	Process PID Feed Fwd Ramp up	0.01 s	All set-ups		TRUE	-2	Uint32
7-53	Process PID Feed Fwd Ramp down	0.01 s	All set-ups		TRUE	-2	Uint32
7-56	Process PID Ref. Filter Time	0.001 s	All set-ups		TRUE	-3	Uint16
7-57	Process PID Fb. Filter Time	0.001 s	All set-ups		TRUE	-3	Uint16

4.1.9 8-** Comm. and Options

Par. No. #	Parameter description	Default value	4-set-up	FC 302 only	Change during operation	Conversion index	Type
8-0* General Settings							
8-01	Control Site	[0] Digital and ctrl. word	All set-ups		TRUE	-	Uint8
8-02	Control Word Source	null	All set-ups		TRUE	-	Uint8
8-03	Control Word Timeout Time	1.0 s	1 set-up		TRUE	-1	Uint32
8-04	Control Word Timeout Function	null	1 set-up		TRUE	-	Uint8
8-05	End-of-Timeout Function	[1] Resume set-up	1 set-up		TRUE	-	Uint8
8-06	Reset Control Word Timeout	[0] Do not reset	All set-ups		TRUE	-	Uint8
8-07	Diagnosis Trigger	[0] Disable	2 set-ups		TRUE	-	Uint8
8-1* Ctrl. Word Settings							
8-10	Control Word Profile	[0] FC profile	All set-ups		TRUE	-	Uint8
8-13	Configurable Status Word STW	null	All set-ups		TRUE	-	Uint8
8-14	Configurable Control Word CTW	[1] Profile default	All set-ups		TRUE	-	Uint8
8-3* FC Port Settings							
8-30	Protocol	[0] FC	1 set-up		TRUE	-	Uint8
8-31	Address	1 N/A	1 set-up		TRUE	0	Uint8
8-32	FC Port Baud Rate	null	1 set-up		TRUE	-	Uint8
8-33	Parity / Stop Bits	[0] Even Parity, 1 Stop Bit	1 set-up		TRUE	-	Uint8
8-35	Minimum Response Delay	10 ms	All set-ups		TRUE	-3	Uint16
8-36	Max Response Delay	ExpressionLimit	1 set-up		TRUE	-3	Uint16
8-37	Max Inter-Char Delay	ExpressionLimit	1 set-up		TRUE	-5	Uint16
8-4* FC MC protocol set							
8-40	Telegram selection	[1] Standard telegram 1	2 set-ups		TRUE	-	Uint8
8-5* Digital/Bus							
8-50	Coasting Select	[3] Logic OR	All set-ups		TRUE	-	Uint8
8-51	Quick Stop Select	[3] Logic OR	All set-ups		TRUE	-	Uint8
8-52	DC Brake Select	[3] Logic OR	All set-ups		TRUE	-	Uint8
8-53	Start Select	[3] Logic OR	All set-ups		TRUE	-	Uint8
8-54	Reverse Select	[3] Logic OR	All set-ups		TRUE	-	Uint8
8-55	Set-up Select	[3] Logic OR	All set-ups		TRUE	-	Uint8
8-56	Preset Reference Select	[3] Logic OR	All set-ups		TRUE	-	Uint8
8-8* FC Port Diagnostics							
8-80	Bus Message Count	0 N/A	All set-ups		TRUE	0	Uint32
8-81	Bus Error Count	0 N/A	All set-ups		TRUE	0	Uint32
8-82	Slave Messages Rcvd	0 N/A	All set-ups		TRUE	0	Uint32
8-83	Slave Error Count	0 N/A	All set-ups		TRUE	0	Uint32
8-9* Bus Jog							
8-90	Bus Jog 1 Speed	100 RPM	All set-ups		TRUE	67	Uint16
8-91	Bus Jog 2 Speed	200 RPM	All set-ups		TRUE	67	Uint16

4.1.10 9- Profibus**

Par. No. #	Parameter description	Default value	4-set-up	FC 302 only	Change during operation	Conversion index	Type
9-00	Setpoint	0 N/A	All set-ups		TRUE	0	Uint16
9-07	Actual Value	0 N/A	All set-ups		FALSE	0	Uint16
9-15	PCD Write Configuration	ExpressionLimit	2 set-ups		TRUE	-	Uint16
9-16	PCD Read Configuration	ExpressionLimit	2 set-ups		TRUE	-	Uint16
9-18	Node Address	126 N/A	1 set-up		TRUE	0	Uint8
9-22	Telegram Selection	[108] PPO 8	1 set-up		TRUE	-	Uint8
9-23	Parameters for Signals	0	All set-ups		TRUE	-	Uint16
9-27	Parameter Edit	[1] Enabled	2 set-ups		FALSE	-	Uint16
9-28	Process Control	[1] Enable cyclic master	2 set-ups		FALSE	-	Uint8
9-44	Fault Message Counter	0 N/A	All set-ups		TRUE	0	Uint16
9-45	Fault Code	0 N/A	All set-ups		TRUE	0	Uint16
9-47	Fault Number	0 N/A	All set-ups		TRUE	0	Uint16
9-52	Fault Situation Counter	0 N/A	All set-ups		TRUE	0	Uint16
9-53	Profibus Warning Word	0 N/A	All set-ups		TRUE	0	V2
9-63	Actual Baud Rate	[255] No baud rate found	All set-ups		TRUE	-	Uint8
9-64	Device Identification	0 N/A	All set-ups		TRUE	0	Uint16
9-65	Profile Number	0 N/A	All set-ups		TRUE	0	Uint16
9-67	Control Word 1	0 N/A	All set-ups		TRUE	0	V2
9-68	Status Word 1	0 N/A	All set-ups		TRUE	0	V2
9-71	Profibus Save Data Values	[0] Off	All set-ups		TRUE	-	Uint8
9-72	ProfibusDriveReset	[0] No action	1 set-up		FALSE	-	Uint8
9-80	Defined Parameters (1)	0 N/A	All set-ups		FALSE	0	Uint16
9-81	Defined Parameters (2)	0 N/A	All set-ups		FALSE	0	Uint16
9-82	Defined Parameters (3)	0 N/A	All set-ups		FALSE	0	Uint16
9-83	Defined Parameters (4)	0 N/A	All set-ups		FALSE	0	Uint16
9-84	Defined Parameters (5)	0 N/A	All set-ups		FALSE	0	Uint16
9-90	Changed Parameters (1)	0 N/A	All set-ups		FALSE	0	Uint16
9-91	Changed Parameters (2)	0 N/A	All set-ups		FALSE	0	Uint16
9-92	Changed Parameters (3)	0 N/A	All set-ups		FALSE	0	Uint16
9-93	Changed Parameters (4)	0 N/A	All set-ups		FALSE	0	Uint16
9-94	Changed parameters (5)	0 N/A	All set-ups		FALSE	0	Uint16
9-99	Profibus Revision Counter	0 N/A	All set-ups		TRUE	0	Uint16

4.1.11 10-** CAN Ser. Com. Bus

Par. No. #	Parameter description	Default value	4-set-up	FC 302 only	Change during operation	Conversion index	Type
10-0* Common Settings							
10-00	CAN Protocol	null	2 set-ups		FALSE	-	Uint8
10-01	Baud Rate Select	null	2 set-ups		TRUE	-	Uint8
10-02	MAC ID	ExpressionLimit	2 set-ups		TRUE	0	Uint8
10-05	Readout Transmit Error Counter	0 N/A	All set-ups		TRUE	0	Uint8
10-06	Readout Receive Error Counter	0 N/A	All set-ups		TRUE	0	Uint8
10-07	Readout Bus Off Counter	0 N/A	All set-ups		TRUE	0	Uint8
10-1* DeviceNet							
10-10	Process Data Type Selection	null	All set-ups		TRUE	-	Uint8
10-11	Process Data Config Write	ExpressionLimit	All set-ups		TRUE	-	Uint16
10-12	Process Data Config Read	ExpressionLimit	All set-ups		TRUE	-	Uint16
10-13	Warning Parameter	0 N/A	All set-ups		TRUE	0	Uint16
10-14	Net Reference	[0] Off	2 set-ups		TRUE	-	Uint8
10-15	Net Control	[0] Off	2 set-ups		TRUE	-	Uint8
10-2* COS Filters							
10-20	COS Filter 1	0 N/A	All set-ups		FALSE	0	Uint16
10-21	COS Filter 2	0 N/A	All set-ups		FALSE	0	Uint16
10-22	COS Filter 3	0 N/A	All set-ups		FALSE	0	Uint16
10-23	COS Filter 4	0 N/A	All set-ups		FALSE	0	Uint16
10-3* Parameter Access							
10-30	Array Index	0 N/A	2 set-ups		TRUE	0	Uint8
10-31	Store Data Values	[0] Off	All set-ups		TRUE	-	Uint8
10-32	Devicenet Revision	ExpressionLimit	All set-ups		TRUE	0	Uint16
10-33	Store Always	[0] Off	1 set-up		TRUE	-	Uint8
10-34	DeviceNet Product Code	ExpressionLimit	1 set-up		TRUE	0	Uint16
10-39	Devicenet F Parameters	0 N/A	All set-ups		TRUE	0	Uint32
10-5* CANopen							
10-50	Process Data Config Write.	ExpressionLimit	2 set-ups		TRUE	-	Uint16
10-51	Process Data Config Read.	ExpressionLimit	2 set-ups		TRUE	-	Uint16

4.1.12 12- Ethernet**

Par. No. #	Parameter description	Default value	4-set-up	FC 302 only	Change during operation	Conversion index	Type
12-0* IP Settings							
12-00	IP Address Assignment	[0] MANUAL	2 set-ups		TRUE	-	UInt8
12-01	IP Address	0 N/A	2 set-ups		TRUE	0	OctStr[4]
12-02	Subnet Mask	0 N/A	2 set-ups		TRUE	0	OctStr[4]
12-03	Default Gateway	0 N/A	2 set-ups		TRUE	0	OctStr[4]
12-04	DHCP Server	0 N/A	2 set-ups		TRUE	0	OctStr[4]
12-05	Lease Expires	ExpressionLimit	All set-ups		TRUE	0	TimD
12-06	Name Servers	0 N/A	2 set-ups		TRUE	0	OctStr[4]
12-07	Domain Name	0 N/A	2 set-ups		TRUE	0	VisStr[48]
12-08	Host Name	0 N/A	2 set-ups		TRUE	0	VisStr[48]
12-09	Physical Address	0 N/A	1 set-up		TRUE	0	VisStr[17]
12-1* Ethernet Link Parameters							
12-10	Link Status	[0] No Link	1 set-up		TRUE	-	UInt8
12-11	Link Duration	ExpressionLimit	All set-ups		TRUE	0	TimD
12-12	Auto Negotiation	[1] On	2 set-ups		TRUE	-	UInt8
12-13	Link Speed	[0] None	2 set-ups		TRUE	-	UInt8
12-14	Link Duplex	[1] Full Duplex	2 set-ups		TRUE	-	UInt8
12-2* Process Data							
12-20	Control Instance	ExpressionLimit	1 set-up		TRUE	0	UInt8
12-21	Process Data Config Write	ExpressionLimit	All set-ups		TRUE	-	UInt16
12-22	Process Data Config Read	ExpressionLimit	All set-ups		TRUE	-	UInt16
12-28	Store Data Values	[0] Off	All set-ups		TRUE	-	UInt8
12-29	Store Always	[0] Off	1 set-up		TRUE	-	UInt8
12-3* EtherNet/IP							
12-30	Warning Parameter	0 N/A	All set-ups		TRUE	0	UInt16
12-31	Net Reference	[0] Off	2 set-ups		TRUE	-	UInt8
12-32	Net Control	[0] Off	2 set-ups		TRUE	-	UInt8
12-33	CIP Revision	ExpressionLimit	All set-ups		TRUE	0	UInt16
12-34	CIP Product Code	ExpressionLimit	1 set-up		TRUE	0	UInt16
12-35	EDS Parameter	0 N/A	All set-ups		TRUE	0	UInt32
12-37	COS Inhibit Timer	0 N/A	All set-ups		TRUE	0	UInt16
12-38	COS Filter	0 N/A	All set-ups		TRUE	0	UInt16
12-8* Other Ethernet Services							
12-80	FTP Server	[0] Disabled	2 set-ups		TRUE	-	UInt8
12-81	HTTP Server	[0] Disabled	2 set-ups		TRUE	-	UInt8
12-82	SMTP Service	[0] Disabled	2 set-ups		TRUE	-	UInt8
12-89	Transparent Socket Channel Port	4000 N/A	2 set-ups		TRUE	0	UInt16
12-9* Advanced Ethernet Services							
12-90	Cable Diagnostic	[0] Disabled	2 set-ups		TRUE	-	UInt8
12-91	MDI-X	[1] Enabled	2 set-ups		TRUE	-	UInt8
12-92	IGMP Snooping	[1] Enabled	2 set-ups		TRUE	-	UInt8
12-93	Cable Error Length	0 N/A	1 set-up		TRUE	0	UInt16
12-94	Broadcast Storm Protection	-1 %	2 set-ups		TRUE	0	Int8
12-95	Broadcast Storm Filter	[0] Broadcast only	2 set-ups		TRUE	-	UInt8
12-98	Interface Counters	4000 N/A	All set-ups		TRUE	0	UInt16
12-99	Media Counters	0 N/A	All set-ups		TRUE	0	UInt16

4.1.13 13-** Smart Logic

Par. No. #	Parameter description	Default value	4-set-up	FC 302 only	Change during operation	Conversion index	Type
13-0* SLC Settings							
13-00	SL Controller Mode	null	2 set-ups		TRUE	-	Uint8
13-01	Start Event	null	2 set-ups		TRUE	-	Uint8
13-02	Stop Event	null	2 set-ups		TRUE	-	Uint8
13-03	Reset SLC	[0] Do not reset SLC	All set-ups		TRUE	-	Uint8
13-1* Comparators							
13-10	Comparator Operand	null	2 set-ups		TRUE	-	Uint8
13-11	Comparator Operator	null	2 set-ups		TRUE	-	Uint8
13-12	Comparator Value	ExpressionLimit	2 set-ups		TRUE	-3	Int32
13-2* Timers							
13-20	SL Controller Timer	ExpressionLimit	1 set-up		TRUE	-3	TimD
13-4* Logic Rules							
13-40	Logic Rule Boolean 1	null	2 set-ups		TRUE	-	Uint8
13-41	Logic Rule Operator 1	null	2 set-ups		TRUE	-	Uint8
13-42	Logic Rule Boolean 2	null	2 set-ups		TRUE	-	Uint8
13-43	Logic Rule Operator 2	null	2 set-ups		TRUE	-	Uint8
13-44	Logic Rule Boolean 3	null	2 set-ups		TRUE	-	Uint8
13-5* States							
13-51	SL Controller Event	null	2 set-ups		TRUE	-	Uint8
13-52	SL Controller Action	null	2 set-ups		TRUE	-	Uint8

4.1.14 14- Special Functions**

Par. No. #	Parameter description	Default value	4-set-up	FC 302 only	Change during operation	Conversion index	Type
14-0* Inverter Switching							
14-00	Switching Pattern	[1] SFAVM	All set-ups		TRUE	-	Uint8
14-01	Switching Frequency	null	All set-ups		TRUE	-	Uint8
14-03	Overmodulation	[1] On	All set-ups		FALSE	-	Uint8
14-04	PWM Random	[0] Off	All set-ups		TRUE	-	Uint8
14-1* Mains On/Off							
14-10	Line Failure	[0] No function	All set-ups		FALSE	-	Uint8
14-11	Line Voltage at Line Fault	ExpressionLimit	All set-ups		TRUE	0	Uint16
14-12	Function at Mains Imbalance	[0] Trip	All set-ups		TRUE	-	Uint8
14-13	Mains Failure Step Factor	1.0 N/A	All set-ups		TRUE	-1	Uint8
14-2* Trip Reset							
14-20	Reset Mode	[0] Manual reset	All set-ups		TRUE	-	Uint8
14-21	Automatic Restart Time	10 s	All set-ups		TRUE	0	Uint16
14-22	Operation Mode	[0] Normal operation	All set-ups		TRUE	-	Uint8
14-23	Typecode Setting	null	2 set-ups		FALSE	-	Uint8
14-24	Trip Delay at Current Limit	60 s	All set-ups		TRUE	0	Uint8
14-25	Trip Delay at Torque Limit	60 s	All set-ups		TRUE	0	Uint8
14-26	Trip Delay at Inverter Fault	ExpressionLimit	All set-ups		TRUE	0	Uint8
14-28	Production Settings	[0] No action	All set-ups		TRUE	-	Uint8
14-29	Service Code	0 N/A	All set-ups		TRUE	0	Int32
14-3* Current Limit Ctrl.							
14-30	Current Lim Cont, Proportional Gain	100 %	All set-ups		FALSE	0	Uint16
14-31	Current Lim Contr, Integration Time	0.020 s	All set-ups		FALSE	-3	Uint16
14-32	Current Lim Ctrl, Filter Time	1.0 ms	All set-ups		TRUE	-4	Uint16
14-35	Stall Protection	[1] Enabled	All set-ups		FALSE	-	Uint8
14-4* Energy Optimizing							
14-40	VT Level	66 %	All set-ups		FALSE	0	Uint8
14-41	AEO Minimum Magnetization	ExpressionLimit	All set-ups		TRUE	0	Uint8
14-42	Minimum AEO Frequency	10 Hz	All set-ups		TRUE	0	Uint8
14-43	Motor Cos-Phi	ExpressionLimit	All set-ups		TRUE	-2	Uint16
14-5* Environment							
14-50	RFI 1	[1] On	1 set-up	x	FALSE	-	Uint8
14-52	Fan Control	[0] Auto	All set-ups		TRUE	-	Uint8
14-53	Fan Monitor	[1] Warning	All set-ups		TRUE	-	Uint8
14-55	Output Filter	[0] No Filter	All set-ups		FALSE	-	Uint8
14-56	Capacitance Output Filter	2.0 uF	All set-ups		FALSE	-7	Uint16
14-57	Inductance Output Filter	7.000 mH	All set-ups		FALSE	-6	Uint16
14-59	Actual Number of Inverter Units	ExpressionLimit	1 set-up		FALSE	0	Uint8
14-7* Compatibility							
14-72	VLT Alarm Word	0 N/A	All set-ups		FALSE	0	Uint32
14-73	VLT Warning Word	0 N/A	All set-ups		FALSE	0	Uint32
14-74	VLT Ext. Status Word	0 N/A	All set-ups		FALSE	0	Uint32
14-8* Options							
14-80	Option Supplied by External 24VDC	[1] Yes	2 set-ups		FALSE	-	Uint8
14-9* Fault Settings							
14-90	Fault Level	null	1 set-up		TRUE	-	Uint8

4.1.15 15-** Drive Information

Par. No. #	Parameter description	Default value	4-set-up	FC 302 only	Change during operation	Conversion index	Type
15-0* Operating Data							
15-00	Operating Hours	0 h	All set-ups		FALSE	74	Uint32
15-01	Running Hours	0 h	All set-ups		FALSE	74	Uint32
15-02	kWh Counter	0 kWh	All set-ups		FALSE	75	Uint32
15-03	Power-ups	0 N/A	All set-ups		FALSE	0	Uint32
15-04	Over Temps	0 N/A	All set-ups		FALSE	0	Uint16
15-05	Over Volts	0 N/A	All set-ups		FALSE	0	Uint16
15-06	Reset kWh Counter	[0] Do not reset	All set-ups		TRUE	-	Uint8
15-07	Reset Running Hours Counter	[0] Do not reset	All set-ups		TRUE	-	Uint8
15-1* Data Log Settings							
15-10	Logging Source	0	2 set-ups		TRUE	-	Uint16
15-11	Logging Interval	ExpressionLimit	2 set-ups		TRUE	-3	TimD
15-12	Trigger Event	[0] FALSE	1 set-up		TRUE	-	Uint8
15-13	Logging Mode	[0] Log always	2 set-ups		TRUE	-	Uint8
15-14	Samples Before Trigger	50 N/A	2 set-ups		TRUE	0	Uint8
15-2* Historic Log							
15-20	Historic Log: Event	0 N/A	All set-ups		FALSE	0	Uint8
15-21	Historic Log: Value	0 N/A	All set-ups		FALSE	0	Uint32
15-22	Historic Log: Time	0 ms	All set-ups		FALSE	-3	Uint32
15-3* Fault Log							
15-30	Fault Log: Error Code	0 N/A	All set-ups		FALSE	0	Uint8
15-31	Fault Log: Value	0 N/A	All set-ups		FALSE	0	Int16
15-32	Fault Log: Time	0 s	All set-ups		FALSE	0	Uint32
15-4* Drive Identification							
15-40	FC Type	0 N/A	All set-ups		FALSE	0	VisStr[6]
15-41	Power Section	0 N/A	All set-ups		FALSE	0	VisStr[20]
15-42	Voltage	0 N/A	All set-ups		FALSE	0	VisStr[20]
15-43	Software Version	0 N/A	All set-ups		FALSE	0	VisStr[5]
15-44	Ordered Typecode String	0 N/A	All set-ups		FALSE	0	VisStr[40]
15-45	Actual Typecode String	0 N/A	All set-ups		FALSE	0	VisStr[40]
15-46	Adj Freq Dr Ordering No.	0 N/A	All set-ups		FALSE	0	VisStr[8]
15-47	Power Card Ordering No.	0 N/A	All set-ups		FALSE	0	VisStr[8]
15-48	LCP ID Num.	0 N/A	All set-ups		FALSE	0	VisStr[20]
15-49	SW ID Control Card	0 N/A	All set-ups		FALSE	0	VisStr[20]
15-50	SW ID Power Card	0 N/A	All set-ups		FALSE	0	VisStr[20]
15-51	Adj Freq Dr Serial No.	0 N/A	All set-ups		FALSE	0	VisStr[10]
15-53	Power Card Serial Number	0 N/A	All set-ups		FALSE	0	VisStr[19]
15-6* Option Ident							
15-60	Option Mounted	0 N/A	All set-ups		FALSE	0	VisStr[30]
15-61	Option SW Version	0 N/A	All set-ups		FALSE	0	VisStr[20]
15-62	Option Ordering No	0 N/A	All set-ups		FALSE	0	VisStr[8]
15-63	Option Serial No	0 N/A	All set-ups		FALSE	0	VisStr[18]
15-70	Option in Slot A	0 N/A	All set-ups		FALSE	0	VisStr[30]
15-71	Slot A Option SW Version	0 N/A	All set-ups		FALSE	0	VisStr[20]
15-72	Option in Slot B	0 N/A	All set-ups		FALSE	0	VisStr[30]
15-73	Slot B Option SW Version	0 N/A	All set-ups		FALSE	0	VisStr[20]
15-74	Option in Slot C0	0 N/A	All set-ups		FALSE	0	VisStr[30]
15-75	Slot C0 Option SW Version	0 N/A	All set-ups		FALSE	0	VisStr[20]
15-76	Option in Slot C1	0 N/A	All set-ups		FALSE	0	VisStr[30]
15-77	Slot C1 Option SW Version	0 N/A	All set-ups		FALSE	0	VisStr[20]
15-9* Parameter Info							
15-92	Defined Parameters	0 N/A	All set-ups		FALSE	0	Uint16
15-93	Modified Parameters	0 N/A	All set-ups		FALSE	0	Uint16
15-98	Drive Identification	0 N/A	All set-ups		FALSE	0	VisStr[40]
15-99	Parameter Metadata	0 N/A	All set-ups		FALSE	0	Uint16

4.1.16 16- Data Readouts**

Par. No. #	Parameter description	Default value	4-set-up	FC 302 only	Change during operation	Conversion index	Type
16-0* General Status							
16-00	Control Word	0 N/A	All set-ups		FALSE	0	V2
16-01	Reference [Unit]	0.000 ReferenceFeedbackUnit	All set-ups		FALSE	-3	Int32
16-02	Reference %	0.0 %	All set-ups		FALSE	-1	Int16
16-03	Status Word	0 N/A	All set-ups		FALSE	0	V2
16-05	Main Actual Value [%]	0.00 %	All set-ups		FALSE	-2	N2
16-09	Custom Readout	0.00 CustomReadoutUnit	All set-ups		FALSE	-2	Int32
16-1* Motor Status							
16-10	Power [kW]	0.00 kW	All set-ups		FALSE	1	Int32
16-11	Power [hp]	0.00 hp	All set-ups		FALSE	-2	Int32
16-12	Motor voltage	0.0 V	All set-ups		FALSE	-1	Uint16
16-13	Frequency	0.0 Hz	All set-ups		FALSE	-1	Uint16
16-14	Motor Current	0.00 A	All set-ups		FALSE	-2	Int32
16-15	Frequency [%]	0.00 %	All set-ups		FALSE	-2	N2
16-16	Torque [Nm]	0.0 Nm	All set-ups		FALSE	-1	Int16
16-17	Speed [RPM]	0 RPM	All set-ups		FALSE	67	Int32
16-18	Motor Thermal	0 %	All set-ups		FALSE	0	Uint8
16-19	KTY sensor temperature	0 °C	All set-ups		FALSE	100	Int16
16-20	Motor Angle	0 N/A	All set-ups		TRUE	0	Uint16
16-22	Torque [%]	0 %	All set-ups		FALSE	0	Int16
16-25	Torque [Nm] High	0.0 Nm	All set-ups		FALSE	-1	Int32
16-3* Drive Status							
16-30	DC Link Voltage	0 V	All set-ups		FALSE	0	Uint16
16-32	Brake Energy /s	0.000 kW	All set-ups		FALSE	0	Uint32
16-33	Brake Energy /2 min	0.000 kW	All set-ups		FALSE	0	Uint32
16-34	Heatsink Temp.	0 °C	All set-ups		FALSE	100	Uint8
16-35	Inverter Thermal	0 %	All set-ups		FALSE	0	Uint8
16-36	Inv. Nom. Current	ExpressionLimit	All set-ups		FALSE	-2	Uint32
16-37	Inv. Max. Current	ExpressionLimit	All set-ups		FALSE	-2	Uint32
16-38	SL Controller State	0 N/A	All set-ups		FALSE	0	Uint8
16-39	Control Card Temp.	0 °C	All set-ups		FALSE	100	Uint8
16-40	Logging Buffer Full	[0] No	All set-ups		TRUE	-	Uint8
16-41	LCP Bottom Statusline	0 N/A	All set-ups		TRUE	0	VisStr[50]
16-5* Ref. & Feedb.							
16-50	External Reference	0.0 N/A	All set-ups		FALSE	-1	Int16
16-51	Pulse Reference	0.0 N/A	All set-ups		FALSE	-1	Int16
16-52	Feedback [Unit]	0.000 ReferenceFeedbackUnit	All set-ups		FALSE	-3	Int32
16-53	Digi Pot Reference	0.00 N/A	All set-ups		FALSE	-2	Int16
16-6* Inputs & Outputs							
16-60	Digital Input	0 N/A	All set-ups		FALSE	0	Uint16
16-61	Terminal 53 Switch Setting	[0] Current	All set-ups		FALSE	-	Uint8
16-62	Analog Input 53	0.000 N/A	All set-ups		FALSE	-3	Int32
16-63	Terminal 54 Switch Setting	[0] Current	All set-ups		FALSE	-	Uint8
16-64	Analog Input 54	0.000 N/A	All set-ups		FALSE	-3	Int32
16-65	Analog Output 42 [mA]	0.000 N/A	All set-ups		FALSE	-3	Int16
16-66	Digital Output [bin]	0 N/A	All set-ups		FALSE	0	Int16
16-67	Freq. Input #29 [Hz]	0 N/A	All set-ups	x	FALSE	0	Int32
16-68	Freq. Input #33 [Hz]	0 N/A	All set-ups		FALSE	0	Int32
16-69	Pulse Output #27 [Hz]	0 N/A	All set-ups		FALSE	0	Int32
16-70	Pulse Output #29 [Hz]	0 N/A	All set-ups	x	FALSE	0	Int32
16-71	Relay Output [bin]	0 N/A	All set-ups		FALSE	0	Int16
16-72	Counter A	0 N/A	All set-ups		TRUE	0	Int32
16-73	Counter B	0 N/A	All set-ups		TRUE	0	Int32
16-74	Prec. Stop Counter	0 N/A	All set-ups		TRUE	0	Uint32
16-75	Analog In X30/11	0.000 N/A	All set-ups		FALSE	-3	Int32
16-76	Analog In X30/12	0.000 N/A	All set-ups		FALSE	-3	Int32
16-77	Analog Out X30/8 [mA]	0.000 N/A	All set-ups		FALSE	-3	Int16
16-78	Analog Out X45/1 [mA]	0.000 N/A	All set-ups		FALSE	-3	Int16
16-79	Analog Out X45/3 [mA]	0.000 N/A	All set-ups		FALSE	-3	Int16
16-8* Fieldbus & FC Port							
16-80	Fieldbus CTW 1	0 N/A	All set-ups		FALSE	0	V2
16-82	Fieldbus REF 1	0 N/A	All set-ups		FALSE	0	N2
16-84	Comm. Option Status	0 N/A	All set-ups		FALSE	0	V2
16-85	FC Port CTW 1	0 N/A	All set-ups		FALSE	0	V2
16-86	FC Port REF 1	0 N/A	All set-ups		FALSE	0	N2
16-9* Diagnosis Readouts							
16-90	Alarm Word	0 N/A	All set-ups		FALSE	0	Uint32
16-91	Alarm word 2	0 N/A	All set-ups		FALSE	0	Uint32
16-92	Warning Word	0 N/A	All set-ups		FALSE	0	Uint32
16-93	Warning word 2	0 N/A	All set-ups		FALSE	0	Uint32
16-94	Ext. Status Word	0 N/A	All set-ups		FALSE	0	Uint32

4.1.17 17-** Motor Feedb.Option

Par. No. #	Parameter description	Default value	4-set-up	FC 302 only	Change during operation	Conversion index	Type
17-1* Inc. Enc. Interface							
17-10	Signal Type	[1] TTL (5V, RS4222)	All set-ups		FALSE	-	Uint8
17-11	Resolution (PPR)	1024 N/A	All set-ups		FALSE	0	Uint16
17-2* Abs. Enc. Interface							
17-20	Protocol Selection	[0] None	All set-ups		FALSE	-	Uint8
17-21	Resolution (Positions/Rev)	ExpressionLimit	All set-ups		FALSE	0	Uint32
17-24	SSI Data Length	13 N/A	All set-ups		FALSE	0	Uint8
17-25	Clock Rate	ExpressionLimit	All set-ups		FALSE	3	Uint16
17-26	SSI Data Format	[0] Gray code	All set-ups		FALSE	-	Uint8
17-34	HIPERFACE Baud rate	[4] 9600	All set-ups		FALSE	-	Uint8
17-5* Resolver Interface							
17-50	Poles	2 N/A	1 set-up		FALSE	0	Uint8
17-51	Input Voltage	7.0 V	1 set-up		FALSE	-1	Uint8
17-52	Input Frequency	10.0 kHz	1 set-up		FALSE	2	Uint8
17-53	Transformation Ratio	0.5 N/A	1 set-up		FALSE	-1	Uint8
17-59	Resolver Interface	[0] Disabled	All set-ups		FALSE	-	Uint8
17-6* Monitoring and App.							
17-60	Feedback Direction	[0] Clockwise	All set-ups		FALSE	-	Uint8
17-61	Feedback Signal Monitoring	[1] Warning	All set-ups		TRUE	-	Uint8

4.1.18 18-** Data Readouts 2

Par. No. #	Parameter description	Default value	4-set-up	FC 302 only	Change during operation	Conversion index	Type
18-90 PID Readouts							
18-90	Process PID Error	0.0 %	All set-ups		FALSE	-1	Int16
18-91	Process PID Output	0.0 %	All set-ups		FALSE	-1	Int16
18-92	Process PID Clamped Output	0.0 %	All set-ups		FALSE	-1	Int16
18-93	Process PID Gain Scaled Output	0.0 %	All set-ups		FALSE	-1	Int16

4.1.19 30-** Special Features

Par. No. #	Parameter description	Default value	4-set-up	FC 302 only	Change during operation	Conversion index	Type
30-0* Wobbler							
30-00	Wobble Mode	[0] Abs. Freq., Abs. Time	All set-ups		FALSE	-	Uint8
30-01	Wobble Delta Frequency [Hz]	5.0 Hz	All set-ups		TRUE	-1	Uint8
30-02	Wobble Delta Frequency [%]	25 %	All set-ups		TRUE	0	Uint8
30-03	Wobble Delta Freq. Scaling Resource	[0] No function	All set-ups		TRUE	-	Uint8
30-04	Wobble Jump Frequency [Hz]	0.0 Hz	All set-ups		TRUE	-1	Uint8
30-05	Wobble Jump Frequency [%]	0 %	All set-ups		TRUE	0	Uint8
30-06	Wobble Jump Time	ExpressionLimit	All set-ups		TRUE	-3	Uint16
30-07	Wobble Sequence Time	10.0 s	All set-ups		TRUE	-1	Uint16
30-08	Wobble Up/ Down Time	5.0 s	All set-ups		TRUE	-1	Uint16
30-09	Wobble Random Function	[0] Off	All set-ups		TRUE	-	Uint8
30-10	Wobble Ratio	1.0 N/A	All set-ups		TRUE	-1	Uint8
30-11	Wobble Random Ratio Max.	10.0 N/A	All set-ups		TRUE	-1	Uint8
30-12	Wobble Random Ratio Min.	0.1 N/A	All set-ups		TRUE	-1	Uint8
30-19	Wobble Delta Freq. Scaled	0.0 Hz	All set-ups		FALSE	-1	Uint16
30-8* Compatibility (I)							
30-80	d-axis Inductance (Ld)	ExpressionLimit	All set-ups		FALSE	-6	Int32
30-81	Brake Resistor (ohm)	ExpressionLimit	All set-ups		TRUE	-2	Uint32
30-83	Speed PID Proportional Gain	ExpressionLimit	All set-ups		TRUE	-4	Uint32
30-84	Process PID Proportional Gain	0.100 N/A	All set-ups		TRUE	-3	Uint16

4.1.20 32- MCO Basic Settings**

Par. No. #	Parameter description	Default value	4-set-up	FC 302 only	Change during operation	Conversion index	Type
32-0* Encoder 2							
32-00	Incremental Signal Type	[1] TTL (5V, RS4222)	2 set-ups		TRUE	-	Uint8
32-01	Incremental Resolution	1024 N/A	2 set-ups		TRUE	0	Uint32
32-02	Absolute Protocol	[0] None	2 set-ups		TRUE	-	Uint8
32-03	Absolute Resolution	8192 N/A	2 set-ups		TRUE	0	Uint32
32-05	Absolute Encoder Data Length	25 N/A	2 set-ups		TRUE	0	Uint8
32-06	Absolute Encoder Clock Frequency	262.000 kHz	2 set-ups		TRUE	0	Uint32
32-07	Absolute Encoder Clock Generation	[1] On	2 set-ups		TRUE	-	Uint8
32-08	Absolute Encoder Cable Length	0 m	2 set-ups		TRUE	0	Uint16
32-09	Encoder Monitoring	[0] Off	2 set-ups		TRUE	-	Uint8
32-10	Rotational Direction	[1] No action	2 set-ups		TRUE	-	Uint8
32-11	User Unit Denominator	1 N/A	2 set-ups		TRUE	0	Uint32
32-12	User Unit Numerator	1 N/A	2 set-ups		TRUE	0	Uint32
32-3* Encoder 1							
32-30	Incremental Signal Type	[1] TTL (5V, RS4222)	2 set-ups		TRUE	-	Uint8
32-31	Incremental Resolution	1024 N/A	2 set-ups		TRUE	0	Uint32
32-32	Absolute Protocol	[0] None	2 set-ups		TRUE	-	Uint8
32-33	Absolute Resolution	8192 N/A	2 set-ups		TRUE	0	Uint32
32-35	Absolute Encoder Data Length	25 N/A	2 set-ups		TRUE	0	Uint8
32-36	Absolute Encoder Clock Frequency	262.000 kHz	2 set-ups		TRUE	0	Uint32
32-37	Absolute Encoder Clock Generation	[1] On	2 set-ups		TRUE	-	Uint8
32-38	Absolute Encoder Cable Length	0 m	2 set-ups		TRUE	0	Uint16
32-39	Encoder Monitoring	[0] Off	2 set-ups		TRUE	-	Uint8
32-40	Encoder Termination	[1] On	2 set-ups		TRUE	-	Uint8
32-5* Feedback Source							
32-50	Source Slave	[2] Encoder 2	2 set-ups		TRUE	-	Uint8
32-51	MCO 302 Last Will	[1] Trip	2 set-ups		TRUE	-	Uint8
32-6* PID Controller							
32-60	Proportional factor	30 N/A	2 set-ups		TRUE	0	Uint32
32-61	Derivative factor	0 N/A	2 set-ups		TRUE	0	Uint32
32-62	Integral factor	0 N/A	2 set-ups		TRUE	0	Uint32
32-63	Limit Value for Integral Sum	1000 N/A	2 set-ups		TRUE	0	Uint16
32-64	PID Bandwidth	1000 N/A	2 set-ups		TRUE	0	Uint16
32-65	Velocity Feed-Forward	0 N/A	2 set-ups		TRUE	0	Uint32
32-66	Acceleration Feed-Forward	0 N/A	2 set-ups		TRUE	0	Uint32
32-67	Max. Tolerated Position Error	20000 N/A	2 set-ups		TRUE	0	Uint32
32-68	Reverse Behavior for Slave	[0] Reversing allowed	2 set-ups		TRUE	-	Uint8
32-69	Sampling Time for PID Control	1 ms	2 set-ups		TRUE	-3	Uint16
32-70	Scan Time for Profile Generator	1 ms	2 set-ups		TRUE	-3	Uint8
32-71	Size of the Control Window (Activation)	0 N/A	2 set-ups		TRUE	0	Uint32
32-72	Size of the Control Window (Deactiv.)	0 N/A	2 set-ups		TRUE	0	Uint32
32-8* Velocity & Accel.							
32-80	Maximum Velocity (Encoder)	1500 RPM	2 set-ups		TRUE	67	Uint32
32-81	Shortest Ramp	1.000 s	2 set-ups		TRUE	-3	Uint32
32-82	Ramp Type	[0] Linear	2 set-ups		TRUE	-	Uint8
32-83	Velocity Resolution	100 N/A	2 set-ups		TRUE	0	Uint32
32-84	Default Velocity	50 N/A	2 set-ups		TRUE	0	Uint32
32-85	Default Acceleration	50 N/A	2 set-ups		TRUE	0	Uint32
32-9* Development							
32-90	Debug Source	[0] Controlcard	2 set-ups		TRUE	-	Uint8

4.1.21 33-** MCO Adv. Settings

Par. No. #	Parameter description	Default value	4-set-up	FC 302 only	Change during operation	Conversion index	Type
33-0* Home Motion							
33-00	Force HOME	[0] Home not forced	2 set-ups		TRUE	-	Uint8
33-01	Zero Point Offset from Home Pos.	0 N/A	2 set-ups		TRUE	0	Int32
33-02	Ramp for Home Motion	10 N/A	2 set-ups		TRUE	0	Uint32
33-03	Velocity of Home Motion	10 N/A	2 set-ups		TRUE	0	Int32
33-04	Behavior during Home Motion	[0] Reverse and index	2 set-ups		TRUE	-	Uint8
33-1* Synchronization							
33-10	Synchronization Factor Master (M:S)	1 N/A	2 set-ups		TRUE	0	Int32
33-11	Synchronization Factor Slave (M:S)	1 N/A	2 set-ups		TRUE	0	Int32
33-12	Position Offset for Synchronization	0 N/A	2 set-ups		TRUE	0	Int32
33-13	Accuracy Window for Position Sync.	1000 N/A	2 set-ups		TRUE	0	Int32
33-14	Relative Slave Velocity Limit	0 %	2 set-ups		TRUE	0	Uint8
33-15	Marker Number for Master	1 N/A	2 set-ups		TRUE	0	Uint16
33-16	Marker Number for Slave	1 N/A	2 set-ups		TRUE	0	Uint16
33-17	Master Marker Distance	4096 N/A	2 set-ups		TRUE	0	Uint32
33-18	Slave Marker Distance	4096 N/A	2 set-ups		TRUE	0	Uint32
33-19	Master Marker Type	[0] Encoder Z positive	2 set-ups		TRUE	-	Uint8
33-20	Slave Marker Type	[0] Encoder Z positive	2 set-ups		TRUE	-	Uint8
33-21	Master Marker Tolerance Window	0 N/A	2 set-ups		TRUE	0	Uint32
33-22	Slave Marker Tolerance Window	0 N/A	2 set-ups		TRUE	0	Uint32
33-23	Start Behavior for Marker Sync	[0] Start Function 1	2 set-ups		TRUE	-	Uint16
33-24	Marker Number for Fault	10 N/A	2 set-ups		TRUE	0	Uint16
33-25	Marker Number for Ready	1 N/A	2 set-ups		TRUE	0	Uint16
33-26	Velocity Filter	0 us	2 set-ups		TRUE	-6	Int32
33-27	Offset Filter Time	0 ms	2 set-ups		TRUE	-3	Uint32
33-28	Marker Filter Configuration	[0] Marker filter 1	2 set-ups		TRUE	-	Uint8
33-29	Filter Time for Marker Filter	0 ms	2 set-ups		TRUE	-3	Int32
33-30	Maximum Marker Correction	0 N/A	2 set-ups		TRUE	0	Uint32
33-31	Synchronization Type	[0] Standard	2 set-ups		TRUE	-	Uint8
33-4* Limit Handling							
33-40	Behavior at End Limit Switch	[0] Call error handler	2 set-ups		TRUE	-	Uint8
33-41	Negative Software End Limit	-500000 N/A	2 set-ups		TRUE	0	Int32
33-42	Positive Software End Limit	500000 N/A	2 set-ups		TRUE	0	Int32
33-43	Negative Software End Limit Active	[0] Inactive	2 set-ups		TRUE	-	Uint8
33-44	Positive Software End Limit Active	[0] Inactive	2 set-ups		TRUE	-	Uint8
33-45	Time in Target Window	0 ms	2 set-ups		TRUE	-3	Uint8
33-46	Target Window LimitValue	1 N/A	2 set-ups		TRUE	0	Uint16
33-47	Size of Target Window	0 N/A	2 set-ups		TRUE	0	Uint16
33-5* I/O Configuration							
33-50	Terminal X57/1 Digital Input	[0] No function	2 set-ups		TRUE	-	Uint8
33-51	Terminal X57/2 Digital Input	[0] No function	2 set-ups		TRUE	-	Uint8
33-52	Terminal X57/3 Digital Input	[0] No function	2 set-ups		TRUE	-	Uint8
33-53	Terminal X57/4 Digital Input	[0] No function	2 set-ups		TRUE	-	Uint8
33-54	Terminal X57/5 Digital Input	[0] No function	2 set-ups		TRUE	-	Uint8
33-55	Terminal X57/6 Digital Input	[0] No function	2 set-ups		TRUE	-	Uint8
33-56	Terminal X57/7 Digital Input	[0] No function	2 set-ups		TRUE	-	Uint8
33-57	Terminal X57/8 Digital Input	[0] No function	2 set-ups		TRUE	-	Uint8
33-58	Terminal X57/9 Digital Input	[0] No function	2 set-ups		TRUE	-	Uint8
33-59	Terminal X57/10 Digital Input	[0] No function	2 set-ups		TRUE	-	Uint8
33-60	Terminal X59/1 and X59/2 Mode	[1] Output	2 set-ups		FALSE	-	Uint8
33-61	Terminal X59/1 Digital Input	[0] No function	2 set-ups		TRUE	-	Uint8
33-62	Terminal X59/2 Digital Input	[0] No function	2 set-ups		TRUE	-	Uint8
33-63	Terminal X59/1 Digital Output	[0] No function	2 set-ups		TRUE	-	Uint8
33-64	Terminal X59/2 Digital Output	[0] No function	2 set-ups		TRUE	-	Uint8
33-65	Terminal X59/3 Digital Output	[0] No function	2 set-ups		TRUE	-	Uint8
33-66	Terminal X59/4 Digital Output	[0] No function	2 set-ups		TRUE	-	Uint8
33-67	Terminal X59/5 Digital Output	[0] No function	2 set-ups		TRUE	-	Uint8
33-68	Terminal X59/6 Digital Output	[0] No function	2 set-ups		TRUE	-	Uint8
33-69	Terminal X59/7 Digital Output	[0] No function	2 set-ups		TRUE	-	Uint8
33-70	Terminal X59/8 Digital Output	[0] No function	2 set-ups		TRUE	-	Uint8
33-8* Global Parameters							
33-80	Activated Program Number	-1 N/A	2 set-ups		TRUE	0	Int8
33-81	Power-up State	[1] Motor ON	2 set-ups		TRUE	-	Uint8
33-82	Drive Status Monitoring	[1] On	2 set-ups		TRUE	-	Uint8
33-83	Behavior After Error	[0] Coast	2 set-ups		TRUE	-	Uint8
33-84	Behavior afterEsc.	[0] Controlled stop	2 set-ups		TRUE	-	Uint8
33-85	MCO Supplied by External 24VDC	[0] No	2 set-ups		TRUE	-	Uint8
33-86	Terminal at alarm	[0] Relay 1	2 set-ups		TRUE	-	Uint8
33-87	Terminal state at alarm	[0] Do nothing	2 set-ups		TRUE	-	Uint8
33-88	Status word at alarm	0 N/A	2 set-ups		TRUE	0	Uint16

4.1.22 34- MCO Data Readouts**

Par. No. #	Parameter description	Default value	4-set-up	FC 302 only	Change during operation	Conversion index	Type
34-0* PCD Write Par.							
34-01	PCD 1 Write to MCO	0 N/A	All set-ups		TRUE	0	Uint16
34-02	PCD 2 Write to MCO	0 N/A	All set-ups		TRUE	0	Uint16
34-03	PCD 3 Write to MCO	0 N/A	All set-ups		TRUE	0	Uint16
34-04	PCD 4 Write to MCO	0 N/A	All set-ups		TRUE	0	Uint16
34-05	PCD 5 Write to MCO	0 N/A	All set-ups		TRUE	0	Uint16
34-06	PCD 6 Write to MCO	0 N/A	All set-ups		TRUE	0	Uint16
34-07	PCD 7 Write to MCO	0 N/A	All set-ups		TRUE	0	Uint16
34-08	PCD 8 Write to MCO	0 N/A	All set-ups		TRUE	0	Uint16
34-09	PCD 9 Write to MCO	0 N/A	All set-ups		TRUE	0	Uint16
34-10	PCD 10 Write to MCO	0 N/A	All set-ups		TRUE	0	Uint16
34-2* PCD Read Par.							
34-21	PCD 1 Read from MCO	0 N/A	All set-ups		TRUE	0	Uint16
34-22	PCD 2 Read from MCO	0 N/A	All set-ups		TRUE	0	Uint16
34-23	PCD 3 Read from MCO	0 N/A	All set-ups		TRUE	0	Uint16
34-24	PCD 4 Read from MCO	0 N/A	All set-ups		TRUE	0	Uint16
34-25	PCD 5 Read from MCO	0 N/A	All set-ups		TRUE	0	Uint16
34-26	PCD 6 Read from MCO	0 N/A	All set-ups		TRUE	0	Uint16
34-27	PCD 7 Read from MCO	0 N/A	All set-ups		TRUE	0	Uint16
34-28	PCD 8 Read from MCO	0 N/A	All set-ups		TRUE	0	Uint16
34-29	PCD 9 Read from MCO	0 N/A	All set-ups		TRUE	0	Uint16
34-30	PCD 10 Read from MCO	0 N/A	All set-ups		TRUE	0	Uint16
34-4* Inputs & Outputs							
34-40	Digital Inputs	0 N/A	All set-ups		TRUE	0	Uint16
34-41	Digital Outputs	0 N/A	All set-ups		TRUE	0	Uint16
34-5* Process Data							
34-50	Actual Position	0 N/A	All set-ups		TRUE	0	Int32
34-51	Commanded Position	0 N/A	All set-ups		TRUE	0	Int32
34-52	Actual Master Position	0 N/A	All set-ups		TRUE	0	Int32
34-53	Slave Index Position	0 N/A	All set-ups		TRUE	0	Int32
34-54	Master Index Position	0 N/A	All set-ups		TRUE	0	Int32
34-55	Curve Position	0 N/A	All set-ups		TRUE	0	Int32
34-56	Track Error	0 N/A	All set-ups		TRUE	0	Int32
34-57	Synchronizing Error	0 N/A	All set-ups		TRUE	0	Int32
34-58	Actual Velocity	0 N/A	All set-ups		TRUE	0	Int32
34-59	Actual Master Velocity	0 N/A	All set-ups		TRUE	0	Int32
34-60	Synchronizing Status	0 N/A	All set-ups		TRUE	0	Int32
34-61	Axis Status	0 N/A	All set-ups		TRUE	0	Int32
34-62	Program Status	0 N/A	All set-ups		TRUE	0	Int32
34-64	MCO 302 Status	0 N/A	All set-ups		TRUE	0	Uint16
34-65	MCO 302 Control	0 N/A	All set-ups		TRUE	0	Uint16
34-7* Diagnosis readouts							
34-70	MCO Alarm Word 1	0 N/A	All set-ups		FALSE	0	Uint32
34-71	MCO Alarm Word 2	0 N/A	All set-ups		FALSE	0	Uint32

4

5 Troubleshooting

5.1.1 Warnings/Alarm Messages

A warning or an alarm is signaled by the relevant LED on the front of the adjustable frequency drive and indicated by a code on the display.

A warning remains active until its cause is no longer present. Under certain circumstances operation of the motor may still be continued. Warning messages may be critical, but are not necessarily so.

In the event of an alarm, the adjustable frequency drive will have tripped. Alarms must be reset to restart operation once their cause has been rectified.

This may be done in three ways:

1. By using the [RESET] control button on the LCP control panel.
2. Via a digital input with the "Reset" function.
3. Via serial communication/optional serial communication bus.



NOTE!

After a manual reset using the [RESET] button on the LCP, the [AUTO ON] button must be pressed to restart the motor.

If an alarm cannot be reset, the reason may be that its cause has not been rectified, or the alarm is trip-locked (see also table on following page).

Alarms that are trip-locked offer additional protection, meaning that the line power supply must be switched off before the alarm can be reset. After being switched back on, the adjustable frequency drive is no longer blocked and may be reset as described above, once the cause has been rectified.

Alarms that are not trip-locked can also be reset using the automatic reset function in par. 14-20 *Reset Mode* (Warning: automatic wake-up is possible!)

If a warning and alarm are marked against a code in the table on the following page, this means that either a warning occurs before an alarm, or that you can specify whether it is a warning or an alarm that is to be displayed for a given fault.

This is possible, for instance, in par. 1-90 *Motor Thermal Protection*. After an alarm or trip, the motor carries on coasting, and the alarm and warning flash. Once the problem has been rectified, only the alarm continues flashing until the adjustable frequency drive is reset.

No.	Description	Warning	Alarm/Trip	Alarm/Trip Lock	Parameter Reference
1	10 Volts low	X			
2	Live zero error	(X)	(X)		Par. 6-01 <i>Live Zero Timeout Function</i>
3	No motor	(X)			Par. 1-80 <i>Function at Stop</i>
4	Line phase loss	(X)	(X)	(X)	Par. 14-12 <i>Function at Mains Imbalance</i>
5	DC link voltage high	X			
6	DC link voltage low	X			
7	DC overvoltage	X	X		
8	DC undervoltage	X	X		
9	Inverter overloaded	X	X		
10	Motor ETR overtemperature	(X)	(X)		Par. 1-90 <i>Motor Thermal Protection</i>
11	Motor thermistor overtemperature	(X)	(X)		Par. 1-90 <i>Motor Thermal Protection</i>
12	Torque limit	X	X		
13	Overcurrent	X	X	X	
14	Ground Fault	X	X	X	
15	Hardware mismatch		X	X	
16	Short Circuit		X	X	
17	Control word timeout	(X)	(X)		Par. 8-04 <i>Control Word Timeout Function</i>
22	Hoist Mech. Brake				
23	Internal Fan Fault	X			
24	External Fan Fault	X			Par. 14-53 <i>Fan Monitor</i>
25	Brake resistor short-circuited	X			
26	Brake resistor power limit	(X)	(X)		Par. 2-13 <i>Brake Power Monitoring</i>
27	Brake chopper short-circuited	X	X		
28	Brake check	(X)	(X)		Par. 2-15 <i>Brake Check</i>
29	Heatsink temp	X	X	X	
30	Motor phase U missing	(X)	(X)	(X)	Par. 4-58 <i>Missing Motor Phase Function</i>
31	Motor phase V missing	(X)	(X)	(X)	Par. 4-58 <i>Missing Motor Phase Function</i>
32	Motor phase W missing	(X)	(X)	(X)	Par. 4-58 <i>Missing Motor Phase Function</i>
33	Soft-charge Fault		X	X	
34	Serial Communication Bus communication fault	X	X		
36	Line failure	X	X		
37	Phase imbalance		X		
38	Internal Fault		X	X	
39	Heatsink sensor		X	X	
40	Overload of Digital Output Terminal 27	(X)			Par. 5-00 <i>Digital I/O Mode</i> , par. 5-01 <i>Terminal 27 Mode</i>
41	Overload of Digital Output Terminal 29	(X)			Par. 5-00 <i>Digital I/O Mode</i> , par. 5-02 <i>Terminal 29 Mode</i>
42	Overload of Digital Output On X30/6	(X)			Par. 5-32 <i>Term X30/6 Digi Out (MCB 101)</i>
42	Overload of Digital Output On X30/7	(X)			Par. 5-33 <i>Term X30/7 Digi Out (MCB 101)</i>
46	Pwr. card supply		X	X	
47	24 V supply low	X	X	X	
48	1.8 V supply low		X	X	
49	Speed limit	X			
50	AMA calibration failed		X		
51	AMA check U_{nom} and I_{nom}		X		
52	AMA low I_{nom}		X		
53	AMA motor too big		X		

Table 5.1: Alarm/Warning code list

No.	Description	Warning	Alarm/Trip	Alarm/Trip Lock	Parameter Reference
54	AMA motor too small		X		
55	AMA parameter out of range		X		
56	AMA interrupted by user		X		
57	AMA timeout		X		
58	AMA internal fault	X	X		
59	Current limit	X			
60	External Interlock	X			
61	Tracking Error	(X)	(X)		Par. 4-30 <i>Motor Feedback Loss Function</i>
62	Output Frequency at Maximum Limit	X			
63	Mechanical Brake Low		(X)		Par. 2-20 <i>Release Brake Current</i>
64	Voltage Limit	X			
65	Control Board Overtemperature	X	X	X	
66	Heatsink Temperature Low	X			
67	Option Configuration has Changed		X		
68	Safe Stop	(X)	(X) ¹⁾		Par. 5-19 <i>Terminal 37 Safe Stop</i>
69	Pwr. Card Temp		X	X	
70	Illegal FC configuration			X	
71	PTC 1 Safe Stop	X	X ¹⁾		Par. 5-19 <i>Terminal 37 Safe Stop</i>
72	Dangerous Failure			X ¹⁾	Par. 5-19 <i>Terminal 37 Safe Stop</i>
73	Safe Stop Auto Restart				
76	Power Unit Set-up	X			
77	Reduced power mode	X			Par. 14-59 <i>Actual Number of Inverter Units</i>
78	Tracking Error				
79	Illegal PS config		X	X	
80	Drive Initialized to Default Value		X		
81	CSIV corrupt				
82	CSIV param error				
85	Profibus/Profisafe Error				
90	Encoder Loss	(X)	(X)		Par. 17-61 <i>Feedback Signal Monitoring S202</i>
91	Analog input 54 wrong settings			X	
100-199	See Instruction Manual for MCO 305				
243	Brake IGBT	X	X		
244	Heatsink temp	X	X	X	
245	Heatsink sensor		X	X	
246	Pwr.card supply		X	X	
247	Pwr.card temp		X	X	
248	Illegal PS config		X	X	
250	New spare part			X	Par. 14-23 <i>Typecode Setting</i>
251	New Type Code		X	X	

Table 5.2: Alarm/Warning code list

(X) Dependent on parameter

1) Cannot be auto reset via par. 14-20 *Reset Mode*

A trip is the action when an alarm has appeared. The trip will coast the motor and can be reset by pressing the reset button or make a reset by a digital input (par. group5-1* [1]). The original event that caused an alarm cannot damage the adjustable frequency drive or cause dangerous conditions. A trip lock is an action that occurs in conjunction with an alarm, which may cause damage to the adjustable frequency drive or connected parts. A trip lock situation can only be reset by power cycling.

<i>LED indication</i>	
Warning	yellow
Alarm	flashing red
Trip locked	yellow and red

Alarm Word Extended Status Word							
Bit	Hex	Dec	Alarm Word	Alarm Word 2	Warning Word	Warning Word 2	Extended Status Word
0	00000001	1	Brake Check (A28)	ServiceTrip, Read/Write	Brake Check (W28)		Ramping
1	00000002	2	Pwr. Card Temp (A69)	ServiceTrip, (reserved)	Pwr. Card Temp (W69)		AMA Running
2	00000004	4	Ground Fault (A14)	ServiceTrip, Type-code/Sparepart	Ground Fault (W14)		Start CW/CCW
3	00000008	8	Ctrl.Card Temp (A65)	ServiceTrip, (reserved)	Ctrl.Card Temp (W65)		Slow Down
4	00000010	16	Ctrl. Word TO (A17)	ServiceTrip, (reserved)	Ctrl. Word TO (W17)		Catch Up
5	00000020	32	Overcurrent (A13)		Overcurrent (W13)		Feedback High
6	00000040	64	Torque Limit (A12)		Torque Limit (W12)		Feedback Low
7	00000080	128	Motor Th Over (A11)		Motor Th Over (W11)		Output Current High
8	00000100	256	Motor ETR Over (A10)		Motor ETR Over (W10)		Output Current Low
9	00000200	512	Inverter Overld. (A9)		Inverter Overld (W9)		Output Freq High
10	00000400	1024	DC undervolt (A8)		DC undervolt (W8)		Output Freq Low
11	00000800	2048	DC overvolt (A7)		DC overvolt (W7)		Brake Check OK
12	00001000	4096	Short Circuit (A16)		DC Voltage Low (W6)		Braking Max
13	00002000	8192	Soft-charge Fault (A33)		DC Voltage High (W5)		Braking
14	00004000	16384	Line ph. Loss (A4)		Line ph. Loss (W4)		Out of Speed Range
15	00008000	32768	AMA Not OK		No Motor (W3)		OVC Active
16	00010000	65536	Live Zero Error (A2)		Live Zero Error (W2)		AC Brake
17	00020000	131072	Internal Fault (A38)	KTY error	10 V Low (W1)	KTY Warn	Password Timelock
18	00040000	262144	Brake Overload (A26)	Fans error	Brake Overload (W26)	Fans Warn	Password Protection
19	00080000	524288	U phase Loss (A30)	ECB error	Brake Resistor (W25)	ECB Warn	
20	00100000	1048576	V phase Loss (A31)		Brake IGBT (W27)		
21	00200000	2097152	W phase Loss (A32)		Speed Limit (W49)		
22	00400000	4194304	Serial Communication Bus Fault (A34)		Serial Communication Bus Fault (W34)		Unused
23	00800000	8388608	24 V Supply Low (A47)		24V Supply Low (W47)		Unused
24	01000000	16777216	Line Failure (A36)		Line Failure (W36)		Unused
25	02000000	33554432	1.8V Supply Low (A48)		Current Limit (W59)		Unused
26	04000000	67108864	Brake Resistor (A25)		Low Temp (W66)		Unused
27	08000000	134217728	Brake IGBT (A27)		Voltage Limit (W64)		Unused
28	10000000	268435456	Option Change (A67)		Encoder loss (W90)		Unused
29	20000000	536870912	Drive Initialized(A80)		Output freq. lim. (W62)		Unused
30	40000000	1073741824	Safe Stop (A68)	PTC 1 Safe Stop (A71)	Safe Stop (W68)	PTC 1 Safe Stop (W71)	Unused
31	80000000	2147483648	Mech. brake low (A63)	Dangerous Failure (A72)	Extended Status Word		Unused

Table 5.3: Description of Alarm Word, Warning Word and Extended Status Word

The alarm words, warning words and extended status words can be read out via serial bus or optional serial communication bus for diagnosis. See also par. 16-94 *Ext. Status Word*.

WARNING 1, 10 Volts low:

The 10 V voltage from terminal 50 on the control card is below 10 V. Remove some of the load from terminal 50, as the 10 V supply is overloaded. Max. 15 mA or minimum 590 Ω.

WARNING/ALARM 2, Live zero error:

The signal on terminal 53 or 54 is less than 50% of the value set in par. 6-10 *Terminal 53 Low Voltage*, par. 6-12 *Terminal 53 Low Current*, par. 6-20 *Terminal 54 Low Voltage*, or par. 6-22 *Terminal 54 Low Current* respectively.

WARNING/ALARM 3, No motor:

No motor has been connected to the output of the adjustable frequency drive.

WARNING/ALARM 4, Mains phase loss:

A phase is missing on the supply side, or the line voltage imbalance is too high.

This message also appears in case of a fault in the input rectifier on the adjustable frequency drive.

Check the supply voltage and supply currents to the adjustable frequency drive.

WARNING 5, DC link voltage high:

The intermediate circuit voltage (DC) is higher than the overvoltage limit of the control system. The adjustable frequency drive is still active.

WARNING 6, DC link voltage low

The intermediate circuit voltage (DC) is below the undervoltage limit of the control system. The adjustable frequency drive is still active.

WARNING/ALARM 7, DC overvoltage:

If the intermediate circuit voltage exceeds the limit, the adjustable frequency drive trips after a time.

Possible corrections:

- Connect a brake resistor
- Extend the ramp time
- Activate functions in par. 2-10 *Brake Function*
- Increase par. 14-26 *Trip Delay at Inverter Fault*

Alarm/warning limits:	3 x 200–240 V [VDC]	3 x 380–500 V [VDC]	3 x 525–600 V [VDC]
Undervoltage	185	373	532
Voltage warning low	205	410	585
Voltage warning high (w/o brake - w/brake)	390/405	810/840	943/965
Overvoltage	410	855	975

The voltages stated are the intermediate circuit voltage of the adjustable frequency drive with a tolerance of ± 5%. The corresponding AC line voltage is the intermediate circuit voltage (DC link) divided by 1.35.

WARNING/ALARM 8, DC undervoltage:

If the intermediate circuit voltage (DC) drops below the “voltage warning low” limit (see table above), the adjustable frequency drive checks if 24 V backup supply is connected.

If no 24 V backup supply is connected, the adjustable frequency drive trips after a given time depending on the unit.

To check whether the supply voltage matches the adjustable frequency drive, see *General Specifications*.

WARNING/ALARM 9, Inverter overloaded:

The adjustable frequency drive is about to cut out because of an overload (too high current for too long). The counter for electronic, thermal inverter protection gives a warning at 98% and trips at 100%, while giving an alarm. You cannot reset the adjustable frequency drive until the counter is below 90%.

The fault is that the adjustable frequency drive has been overloaded by more than 100% for too long.

WARNING/ALARM 10, Motor ETR overtemperature:

According to the electronic thermal protection (ETR), the motor is too hot. You can choose if you want the adjustable frequency drive to give a warning or an alarm when the counter reaches 100% in par. 1-90 *Motor Thermal Protection*. The fault is that the motor is overloaded by more than 100% for too long. Make sure that the motor par. 1-24 *Motor Current* is set correctly.

WARNING/ALARM 11, Motor thermistor overtemp:

The thermistor or the thermistor connection is disconnected. You can choose if you want the adjustable frequency drive to give a warning or an alarm when the counter reaches 100% in par. 1-90 *Motor Thermal Protection*. Make sure that the thermistor is connected correctly between terminal 53 or 54 (analog voltage input) and terminal 50 (+10 V supply), or between terminal 18 or 19 (digital input PNP only) and terminal 50. If aKTYSensor is used, check for correct connection between terminal 54 and 55.

WARNING/ALARM 12, Torque limit:

The torque is higher than the value in par. 4-16 *Torque Limit Motor Mode* (in motor operation) or the torque is higher than the value in par. 4-17 *Torque Limit Generator Mode* (in regenerative operation).

WARNING/ALARM 13, Overcurrent:

The inverter peak current limit (approx. 200% of the rated current) is exceeded. The warning will last approx. 8-12 sec., then the adjustable frequency drive trips and issues an alarm. Turn off the adjustable frequency drive and check if the motor shaft can be turned and if the motor size matches the adjustable frequency drive.

If extended mechanical brake control is selected, trip can be reset externally.

ALARM 14, Ground fault:

There is a discharge from the output phases to ground, either in the cable between the adjustable frequency drive and the motor or in the motor itself.

Turn off the adjustable frequency drive and remove the ground fault.

ALARM 15, Incomplete hardware:

A fitted option is not handled by the present control board (hardware or software).

ALARM 16, Short-circuit

There is short-circuiting in the motor or on the motor terminals.

Turn off the adjustable frequency drive and remove the short-circuit.

WARNING/ALARM 17, Control word timeout:

There is no communication to the adjustable frequency drive.

The warning will only be active when par. 8-04 *Control Word Timeout Function* is NOT set to OFF.

If par. 8-04 *Control Word Timeout Function* is set to *Stop* and *Trip*, a warning appears and the adjustable frequency drive ramps down until it trips, while giving an alarm.

Par. 8-03 *Control Word Timeout Time* could possibly be increased.

ALARM 22, Hst. mech brake:

Report value will show what kind it is. 0 = The torque ref. was not reached before timeout. 1 = There was no brake feedback before timeout.

WARNING 23, Internal fan fault:

The fan warning function is an extra protection function that checks if the fan is running / mounted. The fan warning can be disabled in par. 14-53 *Fan Monitor* (set to [0] Disabled).

WARNING 24, External fan fault:

The fan warning function is an extra protection function that checks if the fan is running / mounted. The fan warning can be disabled in par. 14-53 *Fan Monitor* (set to [0] Disabled).

WARNING 25, Brake resistor short-circuited:

The brake resistor is monitored during operation. If it short-circuits, the brake function is disconnected and the warning appears. The adjustable frequency drive still works, but without the brake function. Turn off the adjustable frequency drive and replace the brake resistor (see par. 2-15 *Brake Check*).

ALARM/WARNING 26, Brake resistor power limit:

The power transmitted to the brake resistor is calculated as a percentage, as a mean value over the last 120 s, on the basis of the resistance value of the brake resistor (par. 2-11 *Brake Resistor (ohm)*) and the intermediate circuit voltage. The warning is active when the dissipated braking energy is higher than 90%. If *Trip* [2] has been selected in par. 2-13 *Brake Power Monitoring*, the adjustable frequency drive cuts out and issues this alarm, when the dissipated braking energy is higher than 100%.

ALARM/ WARNING 27, Brake chopper fault:

The brake transistor is monitored during operation and if it short-circuits, the brake function disconnects and the warning comes up. The adjustable frequency drive is still able to run, but since the brake transistor has short-circuited, substantial power is transmitted to the brake resistor, even if it is inactive.

Turn off the adjustable frequency drive and remove the brake resistor. This alarm/ warning could also occur should the brake resistor overheat. Terminal 104 to 106 are available as brake resistor. Klixon inputs, see section Brake Resistor Temperature Switch.



Warning: There is a risk of substantial power being transmitted to the brake resistor if the brake transistor is short-circuited.

ALARM/WARNING 28, Brake check failed:

Brake resistor fault: the brake resistor is not connected/working.

ALARM 29, Drive overtemperature:

If the enclosure is IP 20 or IP 21/Type 1,, the cut-out temperature of the heatsink is 203°F ±41°F [95°C ±5°C]. The temperature fault cannot be reset until the temperature of the heatsink is below 158°F +9°F [70°C +5°C].

The fault could be:

- Ambient temperature too high
- Too long motor cable

ALARM 30, Motor phase U missing:

Motor phase U between the adjustable frequency drive and the motor is missing.

Turn off the adjustable frequency drive and check motor phase U.

ALARM 31, Motor phase V missing:

Motor phase V between the adjustable frequency drive and the motor is missing.

Turn off the adjustable frequency drive and check motor phase V.

ALARM 32, Motor phase W missing:

Motor phase W between the adjustable frequency drive and the motor is missing.

Turn off the adjustable frequency drive and check motor phase W.

ALARM 33, Inrush fault:

Too many power-ups have occurred within a short time period. See the chapter *General Specifications* for the allowed number of power-ups within one minute.

WARNING/ALARM 34, Serial Communication Bus communication fault:

The serial communication bus on the communication option card is not working correctly. Please check the parameters associated with the module and make sure the module is properly inserted in slot A of the drive. Check the wiring for serial communication bus.

WARNING/ALARM 36, Mains failure:

This warning/alarm is only active if the supply voltage to the adjustable frequency drive is lost and par. 14-10 *Line Failure* is NOT set to OFF. Possible correction: check the fuses to the adjustable frequency drive.

ALARM 37, Phase imbalance:

There is a current imbalance between the power units

ALARM 38, Internal fault:

If this alarm occurs, it may be necessary to contact your Danfoss supplier. Some typical alarm messages:

0	The serial port cannot be initialized. Serious hardware failure
256	The power EEPROM data is defective or too old
512	The control board EEPROM data is defective or too old
513	Communication timeout Reading EEPROM data
514	Communication timeout Reading EEPROM data
515	The Application Orientated Control cannot recognize the EEPROM data.
516	Cannot write to the EEPROM because a write command is in progress.
517	The write command has timed out.
518	Failure in the EEPROM
519	Missing or invalid BarCode data in EEPROM 1024 – 1279 CAN message cannot be sent. (1027 indicate a possible hardware failure)
1281	Digital Signal Processor flash timeout
1282	Power micro software version mismatch
1283	Power EEPROM data version mismatch
1284	Cannot read Digital Signal Processor software version
1299	Option SW in slot A is too old
1300	Option SW in slot B is too old
1311	Option SW in slot C0 is too old
1312	Option SW in slot C1 is too old
1315	Option SW in slot A is not supported (not allowed)
1316	Option SW in slot B is not supported (not allowed)
1317	Option SW in slot C0 is not supported (not allowed)
1318	Option SW in slot C1 is not supported (not allowed)
1536	An exception in the Application Orientated Control is registered. Debug information written in LCP
1792	DSP watchdog is active. Debugging of power part data Motor Orientated Control data not transferred correctly
2049	Power data restarted
2315	Missing SW version from power unit
2816	Stack overflow Control board module
2817	Scheduler slow tasks
2818	Fast tasks
2819	Parameter thread
2820	LCP stack overflow
2821	Serial port overflow
2822	USB port overflow
3072-	Parameter value is outside its limits. Perform an initial-
5122	ization. Parameter number causing the alarm: Subtract the code from 3072. Ex Error code 3238: 3238-3072 = 166 is outside the limit

5123	Option in slot A: Hardware incompatible with control board hardware
5124	Option in slot B: Hardware incompatible with control board hardware
5125	Option in slot C0: Hardware incompatible with control board hardware
5126	Option in slot C1: Hardware incompatible with control board hardware
5376-6231	Out of memory

WARNING 40, Overload of Digital Output Terminal 27

Check the load connected to terminal 27 or remove short-circuit connection. Check par. 5-00 *Digital I/O Mode* and par. 5-01 *Terminal 27 Mode*.

WARNING 41, Overload of Digital Output Terminal 29:

Check the load connected to terminal 29 or remove short-circuit connection. Check par. 5-00 *Digital I/O Mode* and par. 5-02 *Terminal 29 Mode*.

WARNING 42, Overload of Digital Output On X30/6:

Check the load connected to X30/6 or remove short-circuit connection. Check par. 5-32 *Term X30/6 Digi Out (MCB 101)*.

WARNING 42, Overload of Digital Output On X30/7:

Check the load connected to X30/7 or remove short-circuit connection. Check par. 5-33 *Term X30/7 Digi Out (MCB 101)*.

WARNING 47, 24 V supply low:

The external 24 V DC backup power supply may be overloaded, otherwise contact your Danfoss supplier.

WARNING 48, 1.8 V supply low:

Contact your Danfoss supplier.

WARNING 49, Speed limit:

The speed is not within the specified range in par. 4-11 *Motor Speed Low Limit [RPM]* and par. 4-13 *Motor Speed High Limit [RPM]*.

ALARM 50, AMA calibration failed:

The motor is not suitable for the particular size of drive. Start the AMA procedure once again by par 1-29, eventually with a reduced AMA function. If still failing, check the motor data.

ALARM 51, AMA check Unom and Inom:

The setting of the motor voltage, motor current, and motor power is presumably wrong. Make sure the settings.

ALARM 52, AMA low Inom:

The motor current is too low. Check the settings.

ALARM 53, AMA motor too big:

The motor is too big for the AMA to be carried out.

ALARM 54, AMA motor too small:

The motor is too small for the AMA to be carried out.

ALARM 55, AMA par. out of range:

The motor parameter values found from the motor are outside the acceptable range.

ALARM 56, AMA interrupted by user:

The AMA has been interrupted by the user.

ALARM 57, AMA timeout:

Try to start the AMA again a number of times, until the AMA is carried out. Please note that repeated runs may heat the motor to a level where the resistances R_s and R_r are increased. In most cases, however, this is not critical.

ALARM 58, AMA internal fault:

Contact your Danfoss supplier.

WARNING 59, Current limit:

The current is higher than the value in par. 4-18 *Current Limit*.

ALARM/WARNING 61, Tracking Error:

An error between calculated speed and speed measurement from feedback device. The function Warning/Alarm/Disabling setting is in par. 4-30 *Motor Feedback Loss Function*. Accepted error setting in par. 4-31 *Motor Feedback Speed Error* and the allowed time the error occur setting in par. 4-32 *Motor Feedback Loss Timeout*. During a commissioning procedure the function may be effective.

WARNING 62, Output Frequency at Maximum Limit:

The output frequency is higher than the value set in par. 4-19 *Max Output Frequency*. This is a warning in VVC+ mode and an alarm (trip) in flux mode.

ALARM 63, Mechanical Brake Low:

The actual motor current has not exceeded the "release brake" current within the "Start delay" time window.

WARNING 64, Voltage Limit:

The load and speed combination demands a motor voltage higher than the actual DC link voltage.

WARNING/ALARM/TRIP 65, Control Card Overtemperature:

Control card overtemperature: The cut-out temperature of the control card is 176°F [80°C].

WARNING 66, Heatsink Temperature Low:

The heatsink temperature is measured as 32°F [0°C]. This could indicate that the temperature sensor is defect and that the fan speed has thus increased to the maximum in case the power part or control card is very hot.

ALARM 67, Option Configuration has Changed:

One or more options has either been added or removed since the last power-down.

ALARM 68, Safe Stop:

Safe Stop has been activated. To resume normal operation, apply 24 V DC to T-37. Press reset button on LCP.

WARNING 68, Safe Stop:

Safe Stop has been activated. Normal operation is resumed when safe stop is disabled. Warning: Automatic Restart!

ALARM 70, Illegal Adjustable Frequency Drive Configuration:

The current control board and power board combination is illegal.

ALARM 71, PTC 1 Safe Stop:

Safe Stop has been activated from the MCB 112 PTC Thermistor Card (motor too warm). Normal operation can be resumed when the MCB 112 applies 24 V DC to T-37 again (when the motor temperature reaches an acceptable level) and when the digital input from the MCB 112 is deacti-

vated. When that happens, a reset signal must be sent (via Bus, Digital I/O, or by pressing [RESET]).

WARNING 71, PTC 1 Safe Stop:

Safe Stop has been activated from the MCB 112 PTC Thermistor Card (motor too warm). Normal operation can be resumed when the MCB 112 applies 24 V DC to T-37 again (when the motor temperature reaches an acceptable level) and when the digital input from the MCB 112 is deactivated. Warning: Automatic Restart.

ALARM 72, Dangerous Failure:

Safe Stop with Trip Lock. The dangerous failure alarm is issued if the combination of safe stop commands is unexpected. This is the case if the MCB 112 VLT PTC thermistor card enables X44/ 10 but safe stop is somehow not enabled. Furthermore, if the MCB 112 is the only device using safe stop (specified through selection [4] or [5] in par. 5-19), an unexpected combination activates safe stop without the X44/10 being activated. The following table summarizes the unexpected combinations that lead to Alarm 72. Note that if X44/ 10 is activated in selection 2 or 3, this signal is ignored! However, the MCB 112 will still be able to activate safe stop.

Function	No.	X44/ 10 (DI)	Safe Stop T37
PTC 1 Warning	[4]	+	-
		-	+
PTC 1 Alarm	[5]	+	-
		-	+
PTC 1 & Relay	[6]	+	-
A			
PTC 1 & Relay	[7]	+	-
W			
PTC 1 & Relay	[8]	+	-
A/W			
PTC 1 & Relay	[9]	+	-
W/A			

+: activated

-: Not activated

ALARM 78, Tracking Error:

The difference between setpoint value and actual value has exceeded the value in par. 4-35. Disable the function by par. 4-34 or select an alarm/warning also in par. 4-34. Investigate the mechanics around the load and motor. Check feedback connections from motor – encoder – to drive. Select motor feedback function in par 4-30. Adjust tracking error band in par 4-35 and par 4-37.

ALARM 80, Drive Initialized to Default Value:

Parameter settings are initialized to default setting after a manual (three-finger) reset.

ALARM 81, CSIV corrupt:

CSIV file has syntax errors.

ALARM 82, CSIV par. err.:

CSIV failed to init a parameter

ALARM 85, Dang fail PB:

Profibus/Profisafe Error.

ALARM 86, Dang fail DI:

Sensor Error.

ALARM 90, Encoder loss:

Check the connection to encoder option and eventually replace the MCB 102or MCB 103.

ALARM 91, Analog Input 54 Wrong Settings:

Switch S202 has to be set in position OFF (voltage input) when a KTY sensor is connected to analog input terminal 54.

ALARM 250, New Spare Part:

The power or Switch Mode Power Supply has been exchanged. The adjustable frequency drive type code must be restored in the EEPROM. Select the correct type code in par. 14-23 *Typecode Setting* according to the label on unit. Remember to select 'Save to EEPROM' to complete.

ALARM 251, New Type Code:

The adjustable frequency drive has a new type code.

Index

A

Abbreviations	1-2
Ac Brake Max. Current 2-16	3-38
Access To Main Menu W/o Password 0-61	3-15
Access To Quick Menu W/o Password 0-66	3-15
Activate Brake Delay 2-23	3-39
[Activate Brake Speed Hz] 2-22	3-39
[Activate Brake Speed Rpm] 2-21	3-39
Active Set-up 0-10	3-4
Actual Baud Rate 9-63	3-123
Actual Typecode String 15-45	3-172
Actual Value 9-07	3-114
Address 8-31	3-103
Adj Freq Dr Ordering No. 15-46	3-172
Adj Freq Dr Serial No. 15-51	3-173
Aeo Minimum Magnetization 14-41	3-164
Alarm Log	3-171
Alarm Log: Time 15-32	3-172
Alarm Log: Value 15-31	3-171
Alarm Messages	5-1
Alarm Word	3-101
Alarm Word 16-90	3-182
Alarm Word 2 16-91	3-182
Analog In X30/11 16-75	3-181
Analog In X30/12 16-76	3-181
Analog Input 53 16-62	3-179
Analog Input 54 16-64	3-179
Analog Inputs	1-4
[Analog Out X30/8 Ma] 16-77	3-181
[Analog Out X45/1 Ma] 16-78	3-181
[Analog Out X45/3 Ma] 16-79	3-181
[Analog Output 42 Ma] 16-65	3-180
Array Index 10-30	3-132
[Auto On] Key On Lcp 0-42	3-14
Automatic Motor Adaptation (ama) 1-29	3-20
Automatic Restart Time 14-21	3-161

B

Back Emf At 1000 Rpm 1-40	3-22
Baud Rate Select 10-01	3-126
Brake Check 2-15	3-37
Brake Check Condition 2-18	3-38
Brake Control	5-5
Brake Energy /2 Min 16-33	3-176
Brake Energy /s 16-32	3-176
Brake Function 2-10	3-36
Brake Power Limit (kw) 2-12	3-36
Brake Power Monitoring 2-13	3-36
Brake Release Time 2-25	3-40
Brake Resistor (ohm) 2-11	3-36, 3-189
Braking Energy	1-4
Break-away Torque	1-3
Bus Controlled	3-79
Bus Error Count 8-81	3-113
Bus Jog 1 Speed 8-90	3-114
Bus Jog 2 Speed 8-91	3-114
Bus Message Count 8-80	3-113
Bus Password Access 0-67	3-16
[Bypass Speed From Hz] 4-61	3-60

[Bypass Speed From Rpm] 4-60	3-60
[Bypass Speed To Hz] 4-63	3-61
[Bypass Speed To Rpm] 4-62	3-60

C

Cabling	3-138
Can Protocol 10-00	3-126
Capacitance Output Filter 14-56	3-165
Catch Up	3-64
Catch Up/slow-down Value 3-12	3-43
Changed Parameters (1) 9-90	3-125
Changed Parameters (2) 9-91	3-125
Changed Parameters (3) 9-92	3-125
Changed Parameters (5) 9-94	3-126
Change-of-state	3-136, 3-137
Changing A Data Value	2-12
Changing A Group Of Numeric Data Values	2-11
Changing A Text Value	2-11
Changing Data	2-11
Clock Rate 17-25	3-184
Clockwise	3-27
Clockwise Direction 1-06	3-18
Coasting	1-2, 2-3
Coasting Select 8-50	3-111
Comm. Option Status 16-84	3-182
Communication Option	5-6
Comparator Operand 13-10	3-144
Comparator Operator 13-11	3-147
Comparator Value 13-12	3-148
Configurable Control Word Ctw 8-14	3-103
Configuration	3-99, 3-102
Configuration	3-135
Configuration Mode 1-00	3-16
Control Cables	1-10
Control Card Temp. 16-39	3-177
Control Site 8-01	3-99
Control Word 16-00	3-174
Control Word 1 9-67	3-123
Control Word Profile 8-10	3-101
Control Word Source 8-02	3-99
Control Word Timeout Function 8-04	3-99
Control Word Timeout Time 8-03	3-99
Cooling	3-29
Cos Filter 1 10-20	3-131
Cos Filter 2 10-21	3-131
Cos Filter 3 10-22	3-132
Cos Filter 4 10-23	3-132
Counter A 16-72	3-180
Counter B 16-73	3-181
Current Fault Source 16-49	3-177
Current Lim Cont, Proportional Gain 14-30	3-163
Current Lim Contr, Integration Time 14-31	3-164
Current Lim Ctrl, Filter Time 14-32	3-164
Current Limit 4-18	3-55
Custom Readout 16-09	3-175
Custom Readout Max Value 0-32	3-13

D

Data Log Settings	3-168
D-axis Inductance (ld) 1-37	3-22, 3-189
Dc Brake Current 2-01	3-35
[Dc Brake Cut-in Speed Hz] 2-04	3-36

[Dc Brake Cut-in Speed Rpm] 2-03	3-35
Dc Brake Select 8-52	3-111
Dc Braking Time 2-02	3-35
Dc Hold Current 2-00	3-35
Dc Link	5-5
Dc Link Compensation 14-51	3-165
Dc Link Voltage 16-30	3-176
Default Settings	2-1
Defined Parameters 15-92	3-174
Defined Parameters (1) 9-80	3-124
Defined Parameters (2) 9-81	3-124
Defined Parameters (3) 9-82	3-125
Defined Parameters (4) 9-83	3-125
Defined Parameters (5) 9-84	3-125
Definitions	1-2
Device Identification 9-64	3-123
Devicenet	3-127
Devicenet And Can Serial Communication Bus	3-126
Devicenet F Parameters 10-39	3-132
Devicenet Revision 10-32	3-132
Diagnosis Trigger 8-07	3-100
Digi Pot Reference 16-53	3-178
Digital & Relay Bus Control 5-90	3-79
Digital I/o Mode 5-00	3-61
Digital Input 16-60	3-178
[Digital Output Bin] 16-66	3-180
Display Line 1.1 Small 0-20	3-7
Display Mode	2-6
Display Mode - Selection Of Readouts	2-6
Drive Identification	3-172
Drive Information	3-167

E

Edit Set-up 0-11	3-4
Electrical Terminals	1-9
Electronic Terminal Relay	3-32
Encoder Pulses	3-78
End-of-timeout Function 8-05	3-100
Environment	3-164
Estimated Cycle Time 8-34	3-104
Ethernet	3-134, 3-137, 3-138
Ethernet/ip	3-135
Etr	3-176, 5-5
Ext. Status Word 16-94	3-182
External Reference 16-50	3-178

F

Fan Control 14-52	3-165
Fan Monitor 14-53	3-165
Fault Code 9-45	3-122
Fault Level 14-90	3-166
Fault Log: Error Code 15-30	3-171
Fault Message Counter 9-44	3-122
Fault Number 9-47	3-122
Fault Situation Counter 9-52	3-122
Fc Port Baud Rate 8-32	3-103
Fc Port Ctw 1 16-85	3-182
Fc Port Ref 1 16-86	3-182
Fc Type 15-40	3-172
Feedback Direction 17-60	3-185
Feedback Signal Monitoring 17-61	3-185
[Feedback Unit] 16-52	3-178

Fieldbus Ctw 1 16-80	3-181
Fieldbus Ref 1 16-82	3-181
Flux Motor Feedback Source 1-02	3-17
Flying Start 1-73	3-27
Flystart Test Pulses Current 1-58	3-24
Flystart Test Pulses Frequency 1-59	3-24
Forward Open	3-136
Freeze Output	1-2
[Freq. Input #33 Hz] 16-68	3-180
Frequency 16-13	3-175
[Frequency %] 16-15	3-175
Function At Mains Imbalance 14-12	3-160
Function At Stop 1-80	3-28
Function Relay 5-40	3-71

G

Gain Boost Factor 2-28	3-40
General Warning	1-1
Graphical Display	2-1

H

[Hand On] Key On Lcp 0-40	3-13
Heatsink Temp. 16-34	3-177
High Speed Load Compensation 1-61	3-25
Hiperface Baud Rate 17-34	3-184
Historic Log	3-170
Historic Log: Event 15-20	3-171
Historic Log: Time 15-22	3-171
Historic Log: Value 15-21	3-171

I

Igmp	3-138
Incremental Encoder	3-178
Indexed Parameters	2-12
Indicator Lights	2-2
Inductance Output Filter 14-57	3-166
Infinitely Variable Change Of Numeric Data Value	2-12
Initialization	2-1
Input Frequency 17-52	3-184
Input Voltage 17-51	3-184
Intermediate Circuit	5-5
Inv. Max. Current 16-37	3-177
Inv. Nom. Current 16-36	3-177
Inverter Thermal 16-35	3-177
Iron Loss Resistance (rfe) 1-36	3-22

J

Jog	1-2
Jog Ramp Time 3-80	3-51
[Jog Speed Hz] 3-11	3-43
[Jog Speed Rpm] 3-19	3-46

K

Keypad, 0-4*	3-13
Kty Sensor	5-5
Kty Sensor Temperature 16-19	3-176
Kty Sensor Type 1-95	3-34
Kty Thermistor Resource 1-96	3-34
Kty Threshold Level 1-97	3-34
Kwh Counter 15-02	3-167

L

Language 0-01	3-2
Language Package 1	3-2
Language Package 2	3-2
Language Package 3	3-2
Language Package 4	3-2
Lcp	2-13
Lcp Copy 0-50	3-14
Lcp Id Num. 15-48	3-173
Leds	2-1
Line Failure 14-10	3-159
Line Power Supply	1-6
Live Zero Timeout Function 6-01	3-80
Live Zero Timeout Time 6-00	3-80
Load Type 1-67	3-26
Local Control Keys	2-1
Local Mode Configuration 1-05	3-18
Local Reference	3-3
Logging Buffer Full 16-40	3-177
Logging Interval 15-11	3-169
Logging Mode 15-13	3-170
Logging Source 15-10	3-168
Logic Rule Boolean 1 13-40	3-148
Logic Rule Boolean 2 13-42	3-150
Logic Rule Boolean 3 13-44	3-152
Logic Rule Operator 1 13-41	3-150
Logic Rule Operator 2 13-43	3-152
Low Speed Load Compensation 1-60	3-24

M

Mac Id 10-02	3-126
[Main Actual Value %] 16-05	3-175
Main Menu	2-7
Main Menu Mode	2-2
Main Menu Mode	2-10
Main Menu Password 0-60	3-15
Main Reactance	3-20
Main Reactance (xh) 1-35	3-22
Mains Voltage At Mains Fault 14-11	3-160
Max Inter-char Delay 8-37	3-104
Max Output Frequency 4-19	3-55
Max Response Delay 8-36	3-104
Maximum Inertia 1-69	3-26
Maximum Limit 3-93	3-53
Maximum Reference 3-03	3-42
Mcb 113	3-67, 3-68, 3-71
Mcb113	3-89, 3-91
[Min Speed For Function At Stop Hz] 1-82	3-28
[Min Speed For Function At Stop Rpm] 1-81	3-28
[Min Speed Normal Magnetizing Hz] 1-52	3-23
[Min Speed Normal Magnetizing Rpm] 1-51	3-23
Min Value Of User-defined Readout 0-31	3-13
Min. Current At Low Speed 1-66	3-26
Minimum Aeo Frequency 14-42	3-164
Minimum Inertia 1-68	3-26
Minimum Limit 3-94	3-53
Minimum Reference 3-02	3-42
Minimum Response Delay 8-35	3-104
Missing Motor Phase Function 4-58	3-60
Model Shift Frequency 1-53	3-23
Modified Parameters 15-93	3-174

Motor Angle 16-20	3-176
Motor Angle Offset 1-41	3-22
Motor Construction 1-10	3-18
Motor Cont. Rated Torque 1-26	3-20
Motor Control Principle 1-01	3-16
Motor Cos-phi 14-43	3-164
Motor Current 1-24	3-19, 3-175
Motor External Fan 1-91	3-32
Motor Feedback Loss Function 4-30	3-57
Motor Feedback Loss Timeout 4-32	3-57
Motor Feedback Speed Error 4-31	3-57
Motor Frequency 1-23	3-19
Motor Magnetization At Zero Speed 1-50	3-23
Motor Nominal Speed 1-25	3-19
Motor Poles 1-39	3-22
[Motor Power Hp] 1-21	3-19
[Motor Power Kw] 1-20	3-19
Motor Protection	3-29
Motor Speed Direction 4-10	3-54
[Motor Speed High Limit Hz] 4-14	3-55
[Motor Speed High Limit Rpm] 4-13	3-54
[Motor Speed Low Limit Hz] 4-12	3-54
[Motor Speed Low Limit Rpm] 4-11	3-54
Motor Speed Unit 0-02	3-3
Motor Status	3-175
Motor Thermal 16-18	3-176
Motor Thermal Protection 1-90	3-29
Motor Voltage 16-12	3-175
Motor Voltage 1-22	3-19
Multicast	3-138
My Personal Menu 0-25	3-11

N

Net Control 10-15	3-131
Net Reference 10-14	3-131
Network	3-133, 3-136, 3-138
Node Address 9-18	3-118
Numerical Local Control Panel	2-13

O

Off Delay, Relay 5-42	3-73
[Off] Key On Lcp 0-41	3-13
On Delay, Relay 5-41	3-73
On Reference Bandwidth 7-39	3-97
Operating Hours 15-00	3-167
Operating Mode	3-3
Operating State At Power-up (hand) 0-04	3-3
Operation Mode 14-22	3-161
Option Ident.	3-173
Option Mounted 15-60	3-173
Option Ordering No 15-62	3-173
Option Serial No 15-63	3-173
Option Supplied By External 24vdc 14-80	3-166
Option Sw Version 15-61	3-173
Ordered Typecode String 15-44	3-172
Output Filter 14-55	3-165
Output Speed	3-27
Over Temps 15-04	3-167
Over Volts 15-05	3-167
Overload Mode 1-04	3-18
Overmodulation 14-03	3-158
Over-voltage Control 2-17	3-38

P

Parameter Access	3-132
Parameter Edit 9-27	3-121
Parameter Info	3-174
Parameter Metadata 15-99	3-174
Parameter Selection	2-10
Parameter Set-up	2-7
Parameters For Signals 8-41	3-104
Parameters For Signals 9-23	3-118
Parity / Stop Bits 8-33	3-103
Pcd Read Configuration 8-43	3-108
Pcd Read Configuration 9-16	3-115
Pcd Write Configuration 8-42	3-107
Pcd Write Configuration 9-15	3-114
Poles 17-50	3-184
Potentiometer Reference	1-12
Power Card Ordering No. 15-47	3-172
Power Card Serial Number 15-53	3-173
[Power Hp] 16-11	3-175
[Power Kw] 16-10	3-175
Power Restore 3-92	3-53
Power Section 15-41	3-172
Power-ups 15-03	3-167
Prec. Stop Counter 16-74	3-181
Precise Stop Counter Value 1-84	3-29
Precise Stop Function 1-83	3-28
Precise Stop Speed Compensation Delay 1-85	3-29
Preset Reference 3-10	3-42
Preset Reference Select 8-56	3-113
Preset Relative Reference 3-14	3-44
Process Cl Feedback 1 Resource 7-20	3-95
Process Cl Feedback 2 Resource 7-22	3-95
Process Control 9-28	3-121
Process Data Config Read 10-12	3-128
Process Data Config Write 10-11	3-127
Process Data Type Selection 10-10	3-127
Process Pid Clamped Output 18-92	3-186
Process Pid Differentiation Gain Limit 7-36	3-96
Process Pid Error 18-90	3-186
Process Pid Extended Pid 7-50	3-98
Process Pid Fb. Filter Time 7-57	3-98
Process Pid Feed Forward Factor 7-38	3-96
Process Pid Feed Fwd Gain 7-51	3-98
Process Pid Feed Fwd Normal/ Inv. Ctrl. 7-46	3-98
Process Pid Feed Fwd Ramp Down 7-53	3-98
Process Pid Feed Fwd Ramp Up 7-52	3-98
Process Pid Feed Fwd Resource 7-45	3-97
Process Pid Gain Scale At Max. Ref. 7-44	3-97
Process Pid Gain Scale At Min. Ref. 7-43	3-97
Process Pid Gain Scaled Output 18-93	3-186
Process Pid Integral Time 7-34	3-96
Process Pid I-part Reset 7-40	3-97
Process Pid Output 18-91	3-186
Process Pid Output Neg. Clamp 7-41	3-97
Process Pid Output Normal/ Inv. Ctrl. 7-49	3-98
Process Pid Output Pos. Clamp 7-42	3-97
Process Pid Proportional Gain 7-33	3-96, 3-189
Process Pid Ref. Filter Time 7-56	3-98
Profibus Save Data Values 9-71	3-124
Profibus Warning Word 9-53	3-122
Profibusdrivereset 9-72	3-124

Profile Number 9-65	3-123
Programming Set-up 9-70	3-123
Protection Mode	1-8
Protocol 8-30	3-103
Protocol Selection 17-20	3-183
Pulse Filter Time Constant #29 5-54	3-74
Pulse Filter Time Constant #33 5-59	3-75
[Pulse Input #29 Hz] 16-67	3-180
Pulse Out #27 Bus Control 5-93	3-79
Pulse Out #27 Timeout Preset 5-94	3-79
Pulse Out #29 Bus Control 5-95	3-79
Pulse Out #29 Timeout Preset 5-96	3-79
Pulse Out #x30/6 Bus Control 5-97	3-79
Pulse Out #x30/6 Timeout Preset 5-98	3-79
[Pulse Output #27 Hz] 16-69	3-180
[Pulse Output #29 Hz] 16-70	3-180
Pulse Output Max Freq #27 5-62	3-77
Pulse Output Max Freq #29 5-65	3-77
Pulse Output Max Freq #x30/6 5-68	3-78
Pulse Reference 16-51	3-178
Pulse Start/stop	1-11
Pwm Random 14-04	3-158

Q

Quick Menu	2-2, 2-8
Quick Menu Mode	2-2, 2-7
Quick Menu Password 0-65	3-15
Quick Stop Ramp Time 3-81	3-51
Quick Stop Ramp Type 3-82	3-52
Quick Stop S-ramp Ratio At Decel. End 3-84	3-52
Quick Stop S-ramp Ratio At Decel. Start 3-83	3-52
Quick Transfer Of Parameter Settings Between Multiple Adjustable Frequency Drives	2-4

R

Ramp 1 Ramp-down Time 3-42	3-47
Ramp 1 Ramp-up Time 3-41	3-47
Ramp 1 S-ramp Ratio At Accel. End 3-46	3-47
Ramp 1 S-ramp Ratio At Accel. Start 3-45	3-47
Ramp 1 S-ramp Ratio At Decel. End 3-48	3-47
Ramp 1 S-ramp Ratio At Decel. Start 3-47	3-47
Ramp 1 Type 3-40	3-46
Ramp 2 Ramp-down Time 3-52	3-48
Ramp 2 Ramp-up Time 3-51	3-48
Ramp 2 S-ramp Ratio At Accel. End 3-56	3-48
Ramp 2 S-ramp Ratio At Accel. Start 3-55	3-48
Ramp 2 S-ramp Ratio At Decel. End 3-58	3-49
Ramp 2 S-ramp Ratio At Decel. Start 3-57	3-48
Ramp 2 Type 3-50	3-48
Ramp 3 Ramp-down Time 3-62	3-49
Ramp 3 Ramp-up Time 3-61	3-49
Ramp 3 S-ramp Ratio At Accel. End 3-66	3-49
Ramp 3 S-ramp Ratio At Accel. Start 3-65	3-49
Ramp 3 S-ramp Ratio At Decel. End 3-68	3-50
Ramp 3 S-ramp Ratio At Decel. Start 3-67	3-50
Ramp 3 Type 3-60	3-49
Ramp 4 Ramp-down Time 3-72	3-50
Ramp 4 Ramp-up Time 3-71	3-50
Ramp 4 S-ramp Ratio At Accel. End 3-76	3-51
Ramp 4 S-ramp Ratio At Accel. Start 3-75	3-50
Ramp 4 S-ramp Ratio At Decel. End 3-78	3-51
Ramp 4 S-ramp Ratio At Decel. Start 3-77	3-51
Ramp 4 Type 3-70	3-50

Ramp Delay 3-95	3-54
Ramp Time 3-91	3-53
Rated Motor Speed	1-3
Rcd	1-5
Readout Bus Off Counter 10-07	3-127
Readout Receive Error Counter 10-06	3-127
Readout Transmit Error Counter 10-05	3-126
Readout: Edit Set-ups / Channel 0-14	3-6
Readout: Linked Set-ups 0-13	3-6
Reference	3-136
Reference % 16-02	3-174
Reference Function 3-04	3-42
Reference Range 3-00	3-41
Reference Resource 1 3-15	3-44
Reference Resource 2 3-16	3-44
Reference Resource 3 3-17	3-45
Reference Site 3-13	3-43
[Reference Unit] 16-01	3-174
Reference/feedback Unit 3-01	3-41
Regional Settings 0-03	3-3
Relative Scaling Reference Resource 3-18	3-45
[Relay Output Bin] 16-71	3-180
Relay Outputs	3-68
Release Brake Current 2-20	3-39
Reset	2-4
Reset Control Word Timeout 8-06	3-100
Reset Kwh Counter 15-06	3-167
Reset Mode 14-20	3-160
Reset Running Hours Counter 15-07	3-168
Reset Slc 13-03	3-144
[Reset] Key On Lcp 0-43	3-14
Resolution (positions/rev) 17-21	3-183
Resolution (ppr) 17-11	3-183
Resolver Interface 17-59	3-185
Resonance Dampening 1-64	3-25
Resonance Dampening Time Constant 1-65	3-25
Reverse Select 8-54	3-112
Rfi 1 14-50	3-165
Rotor Leakage Reactance (x2) 1-34	3-22
Rotor Resistance (rr) 1-31	3-21
Running Hours 15-01	3-167

S

Safety Precautions	1-7
Samples Before Trigger 15-14	3-170
Serial Communication	1-4
Service Code 14-29	3-163
Setpoint 9-00	3-114
Set-up Copy 0-51	3-15
Set-up Select 8-55	3-112
Shielded/armored	1-10
Signal Type 17-10	3-183
SI Controller Action 13-52	3-155
SI Controller Event 13-51	3-154
SI Controller Mode 13-00	3-140
SI Controller State 16-38	3-177
SI Controller Timer 13-20	3-148
Slave Error Count 8-83	3-113
Slave Messages Rcvd 8-82	3-113
Slip Compensation 1-62	3-25
Slip Compensation Time Constant 1-63	3-25
Software Version 15-43	3-172
Special Functions	3-157

Speed Pid Diff. Gain Limit 7-05	3-93
Speed Pid Differentiation Time 7-04	3-93
Speed Pid Feed Forward Factor 7-08	3-94
Speed Pid Feedback Gear Ratio 7-07	3-94
Speed Pid Feedback Source 7-00	3-92
Speed Pid Integral Time 7-03	3-92
Speed Pid Lowpass Filter Time 7-06	3-93
Speed Pid Proportional Gain 7-02	3-92, 3-189
[Speed Rpm] 16-17	3-176
Speed Up/down	1-12
Ssi Data Format 17-26	3-184
Ssi Data Length 17-24	3-184
Stall Protection 14-35	3-164
Start Current 1-76	3-28
Start Delay	3-26
Start Delay 1-71	3-26
Start Event 13-01	3-140
Start Function	3-26
Start Function 1-72	3-26
Start Select 8-53	3-112
[Start Speed Hz] 1-75	3-28
[Start Speed Rpm] 1-74	3-27
Start/stop	1-11
Stator Leakage Reactance	3-20
Stator Leakage Reactance (x1) 1-33	3-21
Stator Resistance (rs) 1-30	3-21
Status	2-2
Status Messages	2-1
Status Word 16-03	3-174
Status Word 1 9-68	3-123
Step Size 3-90	3-53
Step-by-step	2-12
Stop Delay 2-24	3-39
Stop Event 13-02	3-142
Store Always 10-33	3-132
Store Data Values 10-31	3-132
Sw Id Control Card 15-49	3-173
Sw Id Power Card 15-50	3-173
Switching Frequency 14-01	3-157
Switching Pattern 14-00	3-157
Synchronous Motor Speed	1-3

T

Telegram Selection 9-22	3-118
Term 32/33 Encoder Direction 5-71	3-78
Term 32/33 Pulses Per Revolution 5-70	3-78
Term. 29 High Frequency 5-51	3-74
Term. 29 High Ref./feedb. Value 5-53	3-74
Term. 29 Low Frequency 5-50	3-74
Term. 29 Low Ref./feedb. Value 5-52	3-74
Term. 33 High Frequency 5-56	3-75
Term. 33 High Ref./feedb. Value 5-58	3-75
Term. 33 Low Frequency 5-55	3-75
Term. 33 Low Ref./feedb. Value 5-57	3-75
Term. X30/11 Filter Time Constant 6-36	3-83
Term. X30/11 High Ref./feedb. Value 6-35	3-83
Term. X30/11 Low Ref./feedb. Value 6-34	3-83
Term. X30/12 Filter Time Constant 6-46	3-84
Term. X30/12 High Ref./feedb. Value 6-45	3-84
Term. X30/12 Low Ref./feedb. Value 6-44	3-84
Terminal 27 Mode 5-01	3-61
Terminal 27 Pulse Output Variable 5-60	3-76
Terminal 29 Mode 5-02	3-61

Terminal 29 Pulse Output Variable 5-63	3-77
Terminal 37 Safe Stop 5-19	3-66
Terminal 42 Output 6-50	3-84
Terminal 42 Output Bus Control 6-53	3-86
Terminal 42 Output Filter 6-55	3-86
Terminal 42 Output Max Scale 6-52	3-86
Terminal 42 Output Min Scale 6-51	3-86
Terminal 42 Output Timeout Preset 6-54	3-86
Terminal 53 Filter Time Constant 6-16	3-82
Terminal 53 High Current 6-13	3-81
Terminal 53 High Ref./feedb. Value 6-15	3-82
Terminal 53 High Voltage 6-11	3-81
Terminal 53 Low Current 6-12	3-81
Terminal 53 Low Ref./feedb. Value 6-14	3-81
Terminal 53 Low Voltage 6-10	3-81
Terminal 53 Switch Setting 16-61	3-179
Terminal 54 Filter Time Constant 6-26	3-83
Terminal 54 High Current 6-23	3-82
Terminal 54 High Ref./feedb. Value 6-25	3-82
Terminal 54 High Voltage 6-21	3-82
Terminal 54 Low Current 6-22	3-82
Terminal 54 Low Ref./feedb. Value 6-24	3-82
Terminal 54 Low Voltage 6-20	3-82
Terminal 54 Switch Setting 16-63	3-179
Terminal X30/11 High Voltage 6-31	3-83
Terminal X30/11 Low Voltage 6-30	3-83
Terminal X30/12 High Voltage 6-41	3-84
Terminal X30/12 Low Voltage 6-40	3-83
Terminal X30/8 Bus Control 6-63	3-89
Terminal X30/8 Max. Scale 6-62	3-88
Terminal X30/8 Min. Scale 6-61	3-88
Terminal X30/8 Output 6-60	3-87
Terminal X30/8 Output Timeout Preset 6-64	3-89
Terminal X45/1 Output Min Scale, 6-71	3-90
Terminal X45/3 Output Min Scale, 6-81	3-91
Thermal Load	3-23, 3-176
Thermistor	3-29
Thermistor	1-5
Thermistor Source 1-93	3-33
This Set-up Linked To 0-12	3-5
[Torque %] 16-22	3-176
Torque Characteristics 1-03	3-17
Torque Limit Factor Source 4-20	3-56
Torque Limit Generator Mode 4-17	3-55
Torque Limit Motor Mode 4-16	3-55
[Torque Nm] 16-16	3-175
[Torque Nm] High 16-25	3-176
Torque Pi Integration Time 7-13	3-95
Torque Pi Proportional Gain 7-12	3-95
Torque Ramp Time 2-27	3-40
Torque Ref 2-26	3-40
Tracking Error 4-35	3-58
Tracking Error After Ramping Timeout 4-39	3-58
Tracking Error Function 4-34	3-58
Tracking Error Ramping 4-37	3-58
Tracking Error Ramping Timeout 4-38	3-58
Tracking Error Timeout 4-36	3-58
Transformation Ratio 17-53	3-185
Trigger Event 15-12	3-169
Trip Delay At Current Limit 14-24	3-163
Trip Delay At Inverter Fault 14-26	3-163
Trip Delay At Torque Limit 14-25	3-163
Trip Reset	3-160

U

U/f Characteristic - F 1-56	3-24
U/f Characteristic - U 1-55	3-23
Unit For User-defined Readout 0-30	3-12

V

Vlt Ext. Status Word 14-74	3-166
Voltage 15-42	3-172
Voltage Reduction In Fieldweakening 1-54	3-23
Voltage Reference Via A Potentiometer	1-12
Vt Level 14-40	3-164
Vvcpplus	1-6

W

Warning Current High 4-51	3-59
Warning Current Low 4-50	3-59
Warning Feedback High 4-57	3-60
Warning Feedback Low 4-56	3-60
Warning Parameter 10-13	3-130
Warning Reference High 4-55	3-59
Warning Reference Low 4-54	3-59
Warning Speed High 4-53	3-59
Warning Speed Low 4-52	3-59
Warning Word	3-101
Warning Word 16-92	3-182
Warning Word 2 16-93	3-182
Warnings	5-1
Wobble Delta Freq. Scaled 30-19	3-188
Wobble Delta Freq. Scaling Resource 30-03	3-187
[Wobble Delta Frequency %] 30-02	3-187
[Wobble Delta Frequency Hz] 30-01	3-187
[Wobble Jump Frequency %] 30-05	3-188
[Wobble Jump Frequency Hz] 30-04	3-188
Wobble Jump Time 30-06	3-188
Wobble Mode 30-00	3-187
Wobble Random Function 30-09	3-188
Wobble Random Ratio Max. 30-11	3-188
Wobble Random Ratio Min. 30-12	3-188
Wobble Ratio 30-10	3-188
Wobble Sequence Time 30-07	3-188
Wobble Up/ Down Time 30-08	3-188