

Contents

| | |
|----------------------------------------------------------------|-----------|
| 1. Safety Regulation | 3 |
| Approvals | 3 |
| Symbols | 3 |
| Disposal Instruction | 3 |
| High Voltage | 4 |
| Safety Instructions | 4 |
| Avoid Unintended Start | 5 |
| Safe Stop of FC 300 | 5 |
| Safe Stop Installation (FC 302 and FC 301 - A1 enclosure only) | 7 |
| IT Mains | 7 |
| 2. Introduction | 9 |
| Hardware | 9 |
| VLT Control Card Terminals | 9 |
| Technical Data | 9 |
| Introduction | 9 |
| Option Card Terminals | 9 |
| Encoder Monitor | 10 |
| Option Card Layout | 11 |
| General Technical Data | 11 |
| Description of the Electrical and Fieldbus Interface | 13 |
| Option Card X57 | 15 |
| Option Card X59 | 16 |
| 3. Fieldbus Interface | 17 |
| Fieldbus Interface | 17 |
| Introduction | 17 |
| Data Layout | 17 |
| 4. Programming | 19 |
| Description of Parameters | 19 |
| 5. Application Examples | 35 |
| Application examples | 35 |
| Wiring diagram | 36 |
| Basic Setup | 36 |
| Parameter Settings | 37 |
| Timing of the Electromechanical brake (par. 19-10 to 19-12) | 38 |
| Setting of par. 32-11 and 32-12 | 38 |
| Setting for the Homing Procedure (par. 33-00 to 33-04) | 38 |

| | |
|---------------------------------------------|-----------|
| Programming positions (par. 19-23 to 19-28) | 39 |
| Software Limits (par. 33-41 to 33-44) | 39 |
| Setting par. 32-81 and 19-06 | 39 |
| Other Settings | 40 |
| 6. Troubleshooting | 41 |
| Frequently Asked questions | 41 |
| Error Messages | 42 |
| Glossary of Key Terms | 44 |
| Index | 47 |

1. Safety Regulation

1

1.1.1. Approvals



1.1.2. Symbols

Symbols used in these Operating Instructions.



NB!

Indicates something to be noted by the reader.



Indicates a general warning.



Indicates a high-voltage warning.

*

Indicates default setting

1.1.3. Disposal Instruction



Equipment containing electrical components may not be disposed of together with domestic waste.

It must be separately collected with Electrical and Electronic waste according to local and currently valid legislation.



The FC 300 AutomationDrive DC link capacitors remain charged after power has been disconnected. To avoid electrical shock hazard, disconnect the FC 300 from the mains before carrying out maintenance. When using a PM-motor, make sure it is disconnected. Before doing service on the frequency converter wait at least the amount of time indicated below:

| | | | |
|--------|-------------|---------------|------------|
| FC 300 | 380 - 500 V | 0.25 - 7.5 kW | 4 minutes |
| | | 11 - 75 kW | 15 minutes |
| | | 90 - 200 kW | 20 minutes |
| | | 250 - 400 kW | 40 minutes |
| | 525 - 690 V | 37 - 250 kW | 20 minutes |
| | | 315 - 560 kW | 30 minutes |

**MCO 351 Positioning Controller for
VLT AutomationDrive FC 30x
Operating Instructions
Software version: 1.1x**



These Operating Instructions can be used for all MCO 351 Positioning Controller for VLT AutomationDrive FC 30x frequency converters with software version 1.1x. The software version number can be seen from parameter 19-92.

1.1.4. High Voltage



The voltage of the frequency converter is dangerous whenever the frequency converter is connected to mains. Incorrect installation or operation of the motor or frequency converter may cause damage to the equipment, serious personal injury or death. The instructions in this manual must consequently be observed, as well as applicable local and national rules and safety regulations.



Installation in high altitudes

At altitudes above 2 km, please contact Danfoss Drives regarding PELV.

1.1.5. Safety Instructions

- Make sure the FC 300 is properly connected to earth.
- Do not remove mains plugs or motor plugs while the FC 300 is connected to mains.
- Protect users against supply voltage.
- Protect the motor against overloading according to national and local regulations.
- Motor overload protection is not included in the default settings. To add this function, set parameter 1-90 *Motor thermal protection* to value *ETR trip* or *ETR warning*. For the North American market: ETR functions provide class 20 motor overload protection, in accordance with NEC.
- The earth leakage current exceeds 3.5 mA.
- The [OFF] key is not a safety switch. It does not disconnect the FC 300 from mains.

1.1.6. General Warning



Warning:

Touching the electrical parts may be fatal - even after the equipment has been disconnected from mains.

Also make sure that other voltage inputs have been disconnected, such as load-sharing (linkage of DC intermediate circuit), as well as the motor connection for kinetic back-up.

Using VLT® AutomationDrive FC 300: wait at least 15 minutes.

Shorter time is allowed only if indicated on the nameplate for the specific unit.



Leakage Current

The earth leakage current from the FC 300 exceeds 3.5 mA. To ensure that the earth cable has a good mechanical connection to the earth connection (terminal 95), the cable cross section must be at least 10 mm² or 2 times rated earth wires terminated separately.

Residual Current Device

This product can cause a D.C. current in the protective conductor. Where a residual current device (RCD) is used for extra protection, only an RCD of Type B (time delayed) shall be used on the supply side of this product. See also RCD Application Note MN.90.GX.02.

Protective earthing of the FC 300 and the use of RCD's must always follow national and local regulations.

1.1.7. Before Commencing Repair Work

1. Disconnect the frequency converter from mains
2. Wait for discharge of the DC-link. See period of time on the warning label.
3. Disconnect DC bus terminals 88 and 89
4. Remove motor cable

1.1.8. Avoid Unintended Start

While FC 300 is connected to mains, the motor can be started/stopped using digital commands, bus commands, references or via the Local Control Panel (LCP).

- Disconnect the FC 300 from mains whenever personal safety considerations make it necessary to avoid unintended start.
- To avoid unintended start, always activate the [OFF] key before changing parameters.
- An electronic fault, temporary overload, a fault in the mains supply, or lost motor connection may cause a stopped motor to start. FC 300 with Safe Stop (i.e. FC 301 in A1 enclosure and FC 302) provides protection against unintended start, if the Safe Stop Terminal 37 is on low voltage level or disconnected.

1.1.9. Safe Stop of FC 300

The FC 302, and also the FC301 in A1 enclosure, can perform the safety function *Safe Torque Off* (As defined by IEC 61800-5-2) or *Stop Category 0* (as defined in EN 60204-1).

FC 301 A1 enclosure: When Safe Stop is included in the drive, position 18 of Type Code must be either T or U. If position 18 is B or X, Safe Stop Terminal 37 is not included!

Example:

Type Code for FC 301 A1 with Safe Stop: FC-301PK75T4Z20H4TGCXXSXXXXA0BXCXXXX0

1

It is designed and approved suitable for the requirements of Safety Category 3 in EN 954-1. This functionality is called Safe Stop. Prior to integration and use of Safe Stop in an installation, a thorough risk analysis on the installation must be carried out in order to determine whether the Safe Stop functionality and safety category are appropriate and sufficient. In order to install and use the Safe Stop function in accordance with the requirements of Safety Category 3 in EN 954-1, the related information and instructions of the FC 300 Design Guide MG.33.BX.YY must be followed! The information and instructions of the Operating Instructions are not sufficient for a correct and safe use of the Safe Stop functionality!

| | | | | |
|------------------------------------------------------------------------------------------------------------------------------------------------------------|------------------------------------------------------------------------------------------------------------------------------------------------------------------------------------------------------------|----------------------------------------------------------------------------------------------------------------------------------------------------------------------------------------------------------------------|--------------------------------------------------------|---------------------------------------------------|
| Prüf- und Zertifizierungsstelle im BG-PRÜFZERT | |  BGIA Berufsgenossenschaftliches Institut für Arbeitsschutz Hauptverband der gewerblichen Berufsgenossenschaften | | 130BA373.10 |
| Translation <small>In any case, the German original shall prevail.</small> | | Type Test Certificate | | |
| Name and address of the holder of the certificate: (customer) | | Danfoss Drives A/S, Ulhøes 1 DK-6300 Graasten, Dänemark | | 05 06004 <small>No. of certificate</small> |
| Name and address of the manufacturer: | | Danfoss Drives A/S, Ulhøes 1 DK-6300 Graasten, Dänemark | | |
| Ref. of customer: | Ref. of Test and Certification Body: Apt/Kah VE-Nr. 2003 23220 | Date of issue: 13.04.2005 | | |
| Product designation: | Frequency converter with integrated safety functions | | | |
| Type: | VLT® Automation Drive FC 302 | | | |
| Intended purpose: | Implementation of safety function „Safe Stop“ | | | |
| Testing based on: | EN 954-1, 1997-03, DKE AK 226.03, 1998-06, EN ISO 13849-2; 2003-12, EN 61800-3, 2001-02, EN 61800-5-1, 2003-09, | | | |
| Test certificate: | No.: 2003 23220 from 13.04.2005 | | | |
| Remarks: | The presented types of the frequency converter FC 302 meet the requirements laid down in the test bases. With correct wiring a category 3 according to DIN EN 954-1 is reached for the safety function. | | | |
| The type tested complies with the provisions laid down in the directive 98/37/EC (Machinery). | | | | |
| Further conditions are laid down in the Rules of Procedure for Testing and Certification of April 2004. | | | | |
| Head of certification body  (Prof. Dr. rer. nat. Dietmar Reinert) | | Certification officer  (Dipl.-Ing. R. Apfeld) | | |
| PZB10E 01.05 |  | Postal address: 53754 Sankt Augustin | Office: Alte Heerstraße 111 53757 Sankt Augustin | Phone: 0 22 41/2 31-02 Fax: 0 22 41/2 31-22 34 |

1.1.10. Safe Stop Installation (FC 302 and FC 301 - A1 enclosure only)

To carry out an installation of a Category 0 Stop (EN60204) in conformance with Safety Category 3 (EN954-1), follow these instructions:

1. The bridge (jumper) between Terminal 37 and 24 V DC must be removed. Cutting or breaking the jumper is not sufficient. Remove it entirely to avoid short-circuiting. See jumper on illustration.
2. Connect terminal 37 to 24 V DC by a short-circuit protected cable. The 24 V DC voltage supply must be interruptible by an EN954-1 Category 3 circuit interrupt device. If the interrupt device and the frequency converter are placed in the same installation panel, you can use a regular cable instead of a protected one.
3. Unless the FC302 itself has protection class IP54 and higher, it must be placed in an IP 54 enclosure. Consequently, FC301 A1 must always be placed in an IP 54 enclosure.

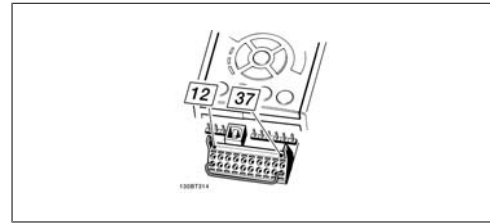

Illustration 1.1: Bridge jumper between terminal 37 and 24 VDC

The illustration below shows a Stopping Category 0 (EN 60204-1) with safety Category 3 (EN 954-1). The circuit interrupt is caused by an opening door contact. The illustration also shows how to connect a non-safety related hardware coast.

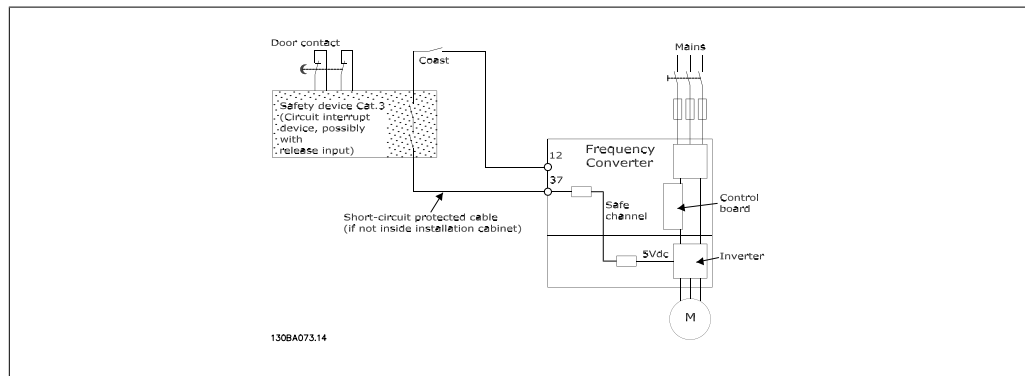

Illustration 1.2: Illustration of the essential aspects of an installation to achieve a Stopping Category 0 (EN 60204-1) with safety Category 3 (EN 954-1).

1.1.11. IT Mains

Par. 14-50 *RFI 1* can on FC 102/202/302 be used to disconnect the internal RFI capacitors from the RFI filter to ground. If this is done it will reduce the RFI performance to A2 level.

2. Introduction

2.1. Hardware

2.1.1. VLT Control Card Terminals

The terminals on the control card are allocated for positioning controller functions the following parameter settings should therefore not be changed in synchronising mode (set-up 1):

Digital inputs 18, 19, 27, 32 and 33

Parameters 510–515 are set to *No operation* (default setting), then the inputs are ignored by the control card but they are used as inputs for the positioning controller.

Analogue inputs 53, 54

Parameters 315, 316 and 317 are set to *No function*, then the inputs are ignored by the control card but they are used as inputs to the positioning controller.

Digital/analogue outputs 42

Parameters 650 are set to: *MCO 0 ... 20 mA [52] analogue output*

2.2. Technical Data

2.2.1. Introduction

Technical data on the control card terminals can be found in the **VLT Automation Drive FC 300 Design Guide**.

2.2.2. Option Card Terminals

There are two encoder interfaces, which cover the following functions:

- Feedback encoder input
- Secondary encoder input

| Terminal X55 | |
|-----------------|----------------------|
| Terminal Number | Descriptive Name |
| | Encoder 2 (Feedback) |
| 1 | + 24 V Supply |
| 2 | + 8 V Supply |
| 3 | + 5 V Supply |
| 4 | GND |
| 5 | A |
| 6 | A not |
| 7 | B |
| 8 | B not |
| 9 | Z / Clock |
| 10 | Z / Clock not |
| 11 | Data |
| 12 | Data not |

| Terminal X56 | |
|-----------------|---------------------|
| Terminal Number | Descriptive Name |
| | Encoder (Secondary) |
| 1 | + 24 V Supply |
| 2 | NC |
| 3 | + 5 V Supply |
| 4 | GND |
| 5 | A |
| 6 | A not |
| 7 | B |
| 8 | B not |
| 9 | Z / Clock |
| 10 | Z / Clock not |
| 11 | Data |
| 12 | Data not |

There are 2 digital input/output terminal blocks, 10 inputs and 8 outputs. (See figure below)

2

| Terminal X57 | |
|-----------------------|------------------|
| Terminal Number | Descriptive Name |
| Digital Inputs | |
| 1 | Digital Input |
| 2 | Digital Input |
| 3 | Digital Input |
| 4 | Digital Input |
| 5 | Digital Input |
| 6 | Digital Input |
| 7 | Digital Input |
| 8 | Digital Input |
| 9 | Digital Input |
| 10 | Digital Input |

| Terminal X59 | |
|-----------------------|------------------|
| Terminal Number | Descriptive Name |
| Digital Output | |
| 1 | Digital Output |
| 2 | Digital Output |
| 3 | Digital Output |
| 4 | Digital Output |
| 5 | Digital Output |
| 6 | Digital Output |
| 7 | Digital Output |
| 8 | Digital Output |

| Terminal X59 | |
|--------------------|------------------|
| Terminal Number | Descriptive Name |
| 24 V Supply | |
| 1 | + 24 V Supply |
| 2 | GND |

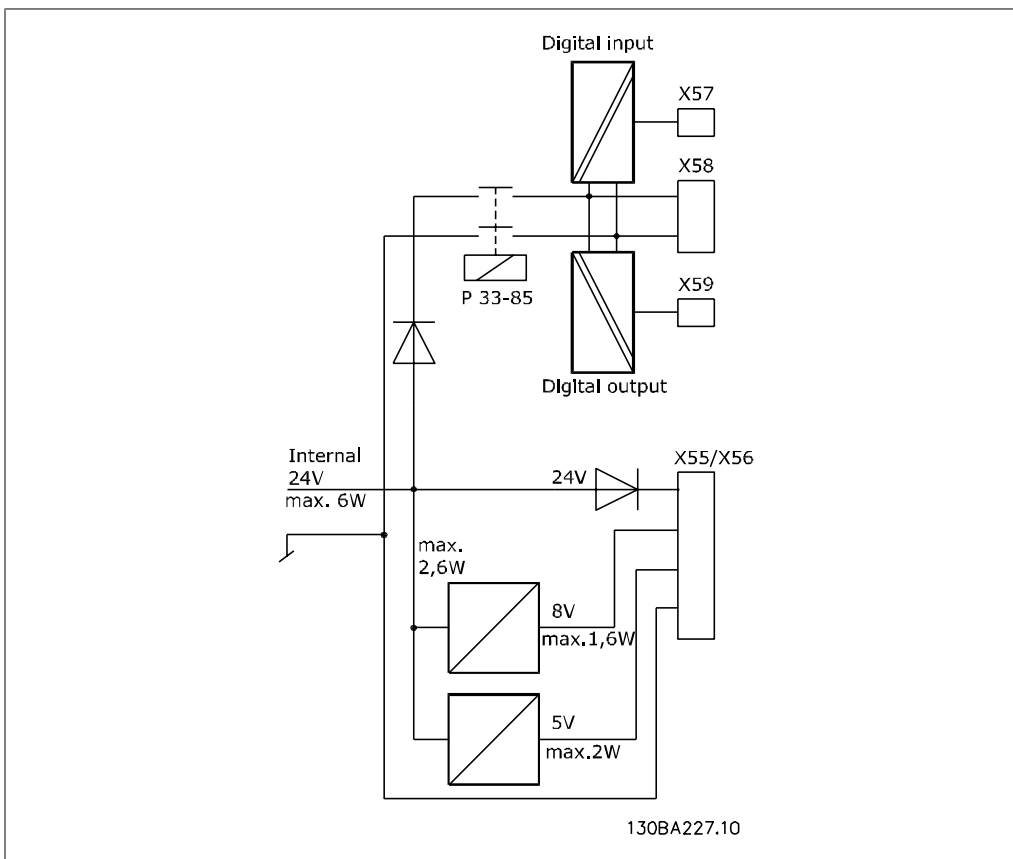

2.2.3. Encoder Monitor

Both encoder interfaces are equipped with a monitoring circuit that can detect open circuit as well as short circuit of each encoder channel. Each encoder channel has a LED showing the status: Green light means OK, no light means fault. An encoder fault will result in an "Option error" 192 if encoder monitoring is activated via parameter 3239 (master) and 3209 (slave).

2.2.4. Option Card Layout

MCO 351 control terminals are plug connectors with screw terminals; the terminal blocks are duplicated to enable use of the same MCO 351 in all frame sizes. See illustration to locate the terminal blocks:

(1) is used with frame sizes A2 and A
 (2) is used with frame sizes A5, B1 and B2
 X55 = Encoder 2
 X56 = Encoder 1
 X57 = Digital inputs
 X58 = 24VDC supply
 X59 = Digital outputs

2.2.5. General Technical Data

- All inputs, outputs and supply voltages are protected against short circuit.
- All inputs, outputs and supply voltages are galvanic isolated from high voltages such as mains supply and motor voltage (PELV).
- Encoder signals are monitored during operation and standstill.
- All MCO 351 parameters including user defined application parameters are accessible via the FC 300 Local Control Panel.
- MCO 351 can be combined with other FC 300 options, namely PROFIBUS and DeviceNet interface.
- All digital inputs and outputs are galvanic isolated from the internal electronics and can be sourced from an external 24V power supply.

Connection Terminals:

| | |
|------------------------------------------------|-----------------------------|
| Maximum cross section, rigid wire | 1.5 mm ² /AWG 16 |
| Maximum cross section, flexible wire | 1.5 mm ² /AWG 16 |
| Maximum cross section, wire with enclosed core | 1.5 mm ² /AWG 16 |
| Minimum cross section | 0.08 ² /AWG 28 |

Digital inputs:

| | |
|--------------------------------------------|-------------------------------------------------------------|
| Number of programmable digital inputs | 10 |
| Terminal block | X57 |
| Terminal number | 1 ¹⁾ , 2 ¹⁾ , 3, 4, 5, 6, 7, 8, 9, 10 |
| Logic | PNP or NPN ¹⁾ |
| Voltage level | 0 - 24 V DC |
| Voltage level | 0 - 24 V DC |
| Voltage level, logic '0' PNP | < 5 DC |
| Voltage level, logic '1' PNP | > 10 V DC |
| Voltage level, logic '0' NPN ²⁾ | > 19 V DC |
| Voltage level, logic '1' NPN ²⁾ | < 14 V DC |
| Maximum voltage on input | 28 V DC |

1)) Selected in parameter 5-00 Digital I/O mode.

The digital inputs are galvanic isolated from the internal electronics and can be sourced by an external 24V power supply.

Digital outputs:

| | |
|----------------------------------------|------------------------------------------------------|
| Number of programmable digital outputs | 8 (6) ¹⁾ |
| Terminal block | X59 |
| Terminal number | 1 ¹⁾ , 2 ¹⁾ , 3, 4, 5, 6, 7, 8 |
| Driver type | push/pull |

| | |
|-----------------------------------------------------------------------------------|--------------------------|
| Logic | PNP or NPN ²⁾ |
| Voltage level | 0 - 24 V DC |
| Max. output current (sink or source) with internal power supply (total Σ) | 40 mA |
| Max. output current (sink or source) with external power supply (per output) | 100 mA |

Terminals X59-1 and X59-2 can be programmed as input, parameter 33-60.

| | |
|---------------------------------------------------------------|--------------------------|
| Combined Digital Inputs/Outputs: | |
| Number of digital outputs which can be used as digital inputs | 2 ¹⁾ |
| Terminal block | X59 |
| Terminal number | 1,2 |
| Logic | PNP or NPN ²⁾ |
| Voltage level | 0 - 24 V DC |
| Voltage level | 0 - 24 V DC |
| Voltage level, logic '0' PNP | < 10 V DC |
| Voltage level, logic '1' PNP | > 17 V DC |
| Voltage level, logic '0' NPN | > 13 V DC |
| Voltage level, logic '1' NPN | < 6 V DC |
| Maximum voltage on input | 28 V DC |

1) Terminals X59-1 and X59-2 can be programmed as input, parameter 33-60.

2) Selected in parameter 5-00 Digital I/O mode.

| | |
|-----------------------|-------|
| 24 V DC Supply Output | |
| Terminal block | X58 |
| Terminal number | 1,2 |
| Maximum load | 65 mA |

The internal 24V power supply can be disconnected via parameter 33-85, an external 24V power supply must then be connected to X58-1 and X58-2.

| | |
|------------------------------------|------------------------------------------------------------------------------------|
| Encoder Inputs | |
| Number of encoder inputs | 2 |
| Terminal block | X55 and X56 |
| Terminal number | 5,6,7,8,9,10,11,12 |
| Input impedance | 120 Ω |
| Maximum voltage on inputs | 5 V DC |
| Cable type | Screened cable with a twisted pair of wires for each encoder channel ¹⁾ |
| Incremental encoder type | RS422/TTL |
| Maximum frequency | 410 kHz |
| Phase displacement between A and B | 90° \pm 30° |
| Maximum cable length | 300 m ¹⁾ |
| Absolute encoder type | SSI |
| Data coding | Gray |
| Data length | 12 - 37 bit |
| Clock frequency | 78 kHz - 2 MHz ¹⁾ |
| Absolute encoder type | SSI |
| Maximum cable length | 150 m ¹⁾ |

1) Always observe specifications/limitations prescribed by the encoder supplier.

2) 150 m cable is possible up to 500 kHz clock frequency, above 500 kHz cable length must be limited further.

| | |
|---------------------------|-------------------------|
| Encoder Output | |
| Number of encoder outputs | 1 |
| Terminal block | X56 |
| Terminal number | 5,6,7,8,9,10,11,12 |
| Signal type | RS 422 Ω |
| Maximum frequency | 410 kHz |
| Maximum number of slaves | 31 (more with repeater) |

| | |
|---------------------------|-------------------------|
| Maximum cable length | 400 m |
| Encoder Output | |
| Number of supply voltages | 3 |
| Terminal block | X55 and X56 |
| Terminal number | 1,2,3,4 |
| 24 V, max load | 250 mA ¹⁾ |
| 8 V, max load | 250 mA ^{1) 2)} |
| 5 V, max load | 400 mA ¹⁾ |
| Absolute encoder type | SSI |
| Maximum cable length | 150 m ¹⁾ |

1) This is maximum load when only one supply voltage is used; when 2 or 3 supply voltages are used simultaneously the load must be reduced accordingly. The following must be observed: $load_{24V} + load_{8V} + load_{5V} \leq 6W$ and $load_{8V} + load_{5V} \leq 2W$.

2) 8 V is only available at terminal block X55.

2.3. Description of the Electrical and Fieldbus Interface

| Terminal | Designation | Description |
|----------|------------------------------|-------------------------------------------------------------------------------------------------------------------------------------------------------------------------------------------------------------------------------------------|
| 12 | 24 V DC | 24V power supply for switches etc. maximum load 200 mA |
| 13 | 24 V DC | 24V power supply for switches etc. maximum load 200 mA |
| 18 | Reference index Bit 0 (LSB) | Reference position index number bit 0 (least significant bit). Not used in fieldbus mode. |
| 19 | Reference index Bit 1 | Reference position index number bit 1. Not used in fieldbus mode. |
| 20 | GND | Ground for 24V is normally bridged with Terminal 39, but can be set to "OFF" by means of Switch SW 4 on the control card. |
| 27 | Reset / ENABLE (error clear) | Errors are cleared on the rising edge (must be "0" min. 1 ms. to guarantee edge detection). Not used in fieldbus mode. To enable operation, this input must be maintained at "1" in either digital control mode or fieldbus control mode. |
| 29 | Reference index Bit 4 (MSB) | Reference position index number bit 4 (most significant bit). Not used in fieldbus mode. Not used in FC 301. |
| 32 | Reference index Bit 3 | Reference position index number bit 3. Not used in fieldbus mode. |
| 33 | Reference index Bit 2 | Reference position index number bit 2. Not used in fieldbus mode. |

| Terminal | Designation | Description |
|----------|----------------------------------------|-----------------------------------------------------------------------------------------------------------------------------------------------------------------------------------------------------------------------------------------------------------------------------------------------------|
| 01 | COM; 240V AC/2A | Common terminal for Relay 01. |
| 02 | Connect to electro-mechanical brake NO | Normal Open Relay 01 is open (brake activated) during power off, and start-up of the FC30x. It is always open after a "Quick Stop" procedure or in connection with an error situation. Relay 01 only closes in connection with motion procedures or if specified in P715. |
| 03 | NC | Normal Closed |
| 04 | COM; 240V AC/2A; 400V DC/2A | Common terminal for Relay 02. |
| 05 | Brake activated NC | Normal Closed Relay 02 is closed to indicate an activated electromechanical brake. It is open to indicate a deactivated electromechanical brake. Not used in fieldbus control mode. |
| 06 | NO | Normal Open |
| 39 | GND | Ground for analogue inputs/outputs is normally bridged with Terminal 20, but can be set to "OFF" by means of Switch SW 4 on the control card. |
| 50 | 10V DC 17mA | Power supply for manual JOG inputs (terminal 53 and 54) |
| 53 | ± 10V-In Manual jog positive | When high (above 5V), the drive will travel with jogging speed (P1916) and ramp (P1917) in the positive direction. When low (below 5V), the drive will ramp down and stop if no other motion procedure is activated. Jog positive has higher priority than Jog negative. Not used in fieldbus mode. |
| 54 | ± 10V-In Manual jog negative | When high (above 5V), the drive will travel with jogging speed (P1916) and ramp (P1917) in the negative direction. When low (below 5V), the drive will ramp down and stop if no other motion procedure is activated. Not used in fieldbus mode. |

2.3.1. Option Card X57

| Terminal | Designation | Description |
|----------|-------------------------------------------|------------------------------------------------------------------------------------------------------------------------------------------------------------------------------------------------------------------------------------------------------------------------------------------------------------------------|
| 1 | Touch probe switch input | Interrupt triggered on the rising edge. If this signal goes high when no touch probe target position is currently locked a new touch probe target position is calculated and locked in memory. |
| 2 | Positive HW limit switch input | Interrupt triggered on the falling edge. Triggers a HW limit error and the drive is stopped according to P1906. |
| 3 | Negative HW limit switch input | Interrupt triggered on the falling edge. Triggers a HW limit error and the drive is stopped according to P1906. |
| 4 | HOME reference switch input | Active high. Marks the HOME position in the application. |
| 5 | Go to the referenced target position | Active high. Upon activation the drive goes to the specified target position. A low signal interrupts any positioning sequence. Not used in fieldbus mode. |
| 6 | Reset home flag | Active high. This input clears the home flag. This allows the user to perform a second homing sequence. Not used in fieldbus mode. |
| 7 | Reset touch probe position | Active high. This input clears the touch probe position flag. The reset is necessary to carry out a touch probe positioning command to a new target position. Not used in fieldbus mode. |
| 8 | Quick stop | Active low. This input activates the Quick Stop function. The drive is stopped according to the setting of P1906. After that the electromechanical brake is always activated when the "Quick stop" input is activated regardless of the P1906 setting. |
| 9 | Go to HOME position | While this input is high the drive executes the homing sequence. While this input is high no position or jog operations are carried out. Any homing sequence is interrupted by a low state on this input. Not used in fieldbus mode. |
| 10 | LATCH new reference position index number | Active on the rising edge (must be "0" min. 1 ms. to guarantee edge detection): Latches reference position index number specified on terminal 18, 19, 29, 32, 33 into memory. Digital output 4 – 8 is changed to mirror the new reference index specified when using digital input control. Not used in fieldbus mode. |

2.3.2. Option Card X59

2

| Terminal Designation | Description |
|-------------------------------|-----------------------------------------------------------------------------------------------------------------------------------------------------------------------------------------------------------------------------------|
| 1 Homing completed | Active high. This output is always high if an absolute encoder is used. |
| 2 Referenced position reached | Active high. This output is set when the target position is reached according to the setting of P3347. |
| 3 Error occurred | Active high. This output is set every time an error occurs. It is cleared every time a successful error clear is carried out. This output will remain high as long as the Power recovery function is selected (P1908) and active. |
| 4 Reference index bit 0 | Active high. Mirror of the currently locked-in reference index bit 0. Not used in fieldbus mode. |
| 5 Reference index bit 1 | Active high. Mirror of the currently locked-in reference index bit 1. Not used in fieldbus mode. |
| 6 Reference index bit 2 | Active high. Mirror of the currently locked-in reference index bit 2. Not used in fieldbus mode. |
| 7 Reference index bit 3 | Active high. Mirror of the currently locked-in reference index bit 3. Not used in fieldbus mode. |
| 8 Reference index bit 4 | Active high. Mirror of the currently locked-in reference index bit 4. Not used in fieldbus mode. |

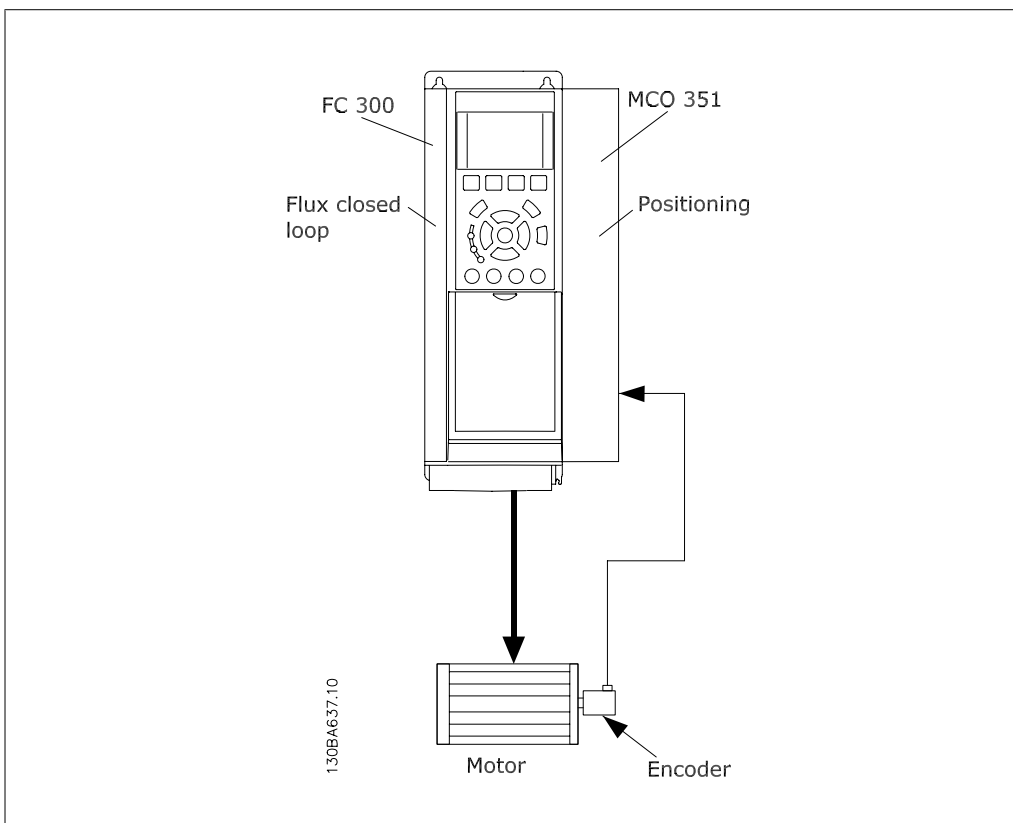

3. Fieldbus Interface

3.1. Fieldbus Interface

3.1.1. Introduction

3

 This section is only relevant if the frequency converter is equipped with a Fieldbus interface (option) as well as the Positioning controller.

The Positioning controller can be controlled via the digital/analogue inputs or via fieldbus. The control source can be selected in parameter 19-04. There can only be one control source at a time meaning that the digital/analogue inputs are inactive when fieldbus is selected as control source and visa versa. The only exceptions are listed in the digital interface section. In fieldbus mode it is possible to specify only the target position and velocity. If the acceleration and deceleration PCDs are left blank then the last used acceleration and deceleration chosen via a quickbus is used. This enables the use of PPO type 4.

3.1.2. Data Layout

Control and status signals are transferred via the so-called process data channel (PCD) of the various fieldbus interfaces. The telegram structure and the available number of data words depends on the fieldbus used, please refer to the manual of the fieldbus option in use for further details. The below example is based on the layout of a PROFIBUS telegram, the so-called PPO: Example using PROFIBUS PPO type 5:

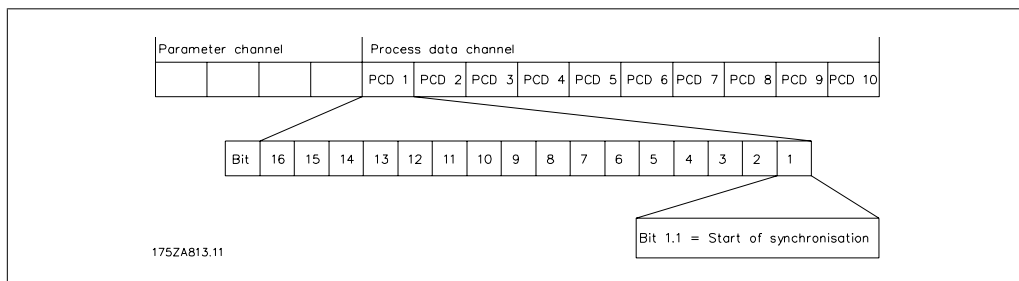

| Fieldbus Control Signals | | |
|--------------------------|--------------------------------------------------------|--------------------------|
| Fieldbus [word.bit] | Fieldbus Mode | Corresponding Input |
| 1.1 | Quick bus go to target (↑) | N\A |
| 1.2 | Reset error (↑) | 27 |
| 1.3 | Go to home / Stop positioning (↑) / Go to position (↓) | 9 |
| 1.4 | Read new trajectory index (↑) | 10 |
| 1.5 | Automatic (↑) / manual(↓)mode | 5 |
| 1.6 | Reset home status (↑) | 6 |
| 1.7 | Reset touch probe position (↑) | 7 |
| 1.8 | Quick stop (↓) | 8 |
| 1.9 | Positive jog (↑) | 53 |
| 1.10 | Negative jog (↑) | 54 |
| 1.11 | Quick Bus Type Absolute (↑) | N\A |
| 1.12 | Quick Bus Type Relative (↑) | N\A |
| 1.13 | Quick Bus Type Touch Probe positive (↑) | N\A |
| 1.14 | Quick Bus Type Touch Probe negative (↑) | N\A |
| 1.15 | Teach in (via LCP or fieldbus) (↑) | KEYPAD "Back" & "Cancel" |
| 1.16 | Change sign on Quick Bus Target Position (↑) | N\A |
| 2 | Quick Bus Target Position(MSB) | N\A |
| 3 | Quick Bus Target Position (LSB) | N\A |
| 4 | Quick Bus Target Velocity | N\A |
| 5 | Quick Bus Target Acceleration | N\A |
| 6 | Quick Bus Target Deceleration | N\A |
| 7.1 | Reference index bit 0 (LSB) (↑) | 18 |
| 7.2 | Reference index bit 1 (↑) | 19 |
| 7.3 | Reference index bit 2 (↑) | 29 |
| 7.4 | Reference index bit 3 (↑) | 32 |
| 7.5 | Reference index bit 4 (↑) | 33 |
| 7.6 | Reference index bit 5 (Fieldbus MSB) (↑) | N\A |

| Fieldbus Status Signals | | |
|-------------------------|----------------------------------------|--------------------------------|
| Fieldbus [word.bit] | Fieldbus Mode | Corresponding Output/Parameter |
| 1.1 | Homing done (↑) | 1 |
| 1.2 | Referenced position reached (↑) | 2 |
| 1.3 | Error occurred (↑) | 3 |
| 1.4 | Electro-mechanical brake output (↑) | 04 |
| 1.5 | Touch probe position locked (↑) | N/A |
| 1.6 | Watchdog output (toggling) | N/A |
| 1.7 | Positive hardware limit (↑) | N\A |
| 1.8 | Negative hardware limit (↑) | N\A |
| 2.1 | Current index bit 0 (LSB) (↑) | 4 |
| 2.2 | Current index bit 1 (↑) | 5 |
| 2.3 | Current index bit 2 (↑) | 6 |
| 2.4 | Current index bit 3 (↑) | 7 |
| 2.5 | Current index bit 4 (↑) | 8 |
| 2.6 | Current index bit 5 (Fieldbus MSB) (↑) | N\A |
| 3 | Actual Position (MSB) | 3450 (MSB) |
| 4 | Actual Position (LSB) | 3450 (LSB) |
| 5 | Error Status | Par. 19-93 |

4. Programming

4.1. Description of Parameters

19-00 VLT local mode

| Option: | Function: |
|-------------------|--------------------------------------------------------------------------------------------------------|
| [0] * Pos control | |
| [1] VLT control | By setting this parameter to 1 the VLT changes to setup "2" Manual running of the VLT is now possible. |

19-01 Endless positioning

| Range: | Function: |
|-----------|-----------------------------------------------------------------------------------------------------------------------------------------------------------------------------|
| 0 [0...1] | Set this parameter to "1" if drive must perform positioning continuously in one direction. Remember to also set parameter POWER RECOVERY, par. 33-43 and par. 33-44 to "0". |

19-02 Block reversal

| Option: | Function: |
|-------------------|--------------------------------------------------------------------------------------------------------------------------------------------------------|
| [0] * No blocking | Selecting "0" disables the function. |
| [1] Block reverse | By selecting "1" it is defined as an error situation ("Reverse operation prohibited" – ERROR STATUS = 12) if the drive is moving in reverse direction. |
| [2] Block forward | By selecting "2" it is defined as an error situation ("Forward operation prohibited" – ERROR STATUS = 13) if the drive is moving in forward direction. |

19-03 Touch probe delay

| Range: | Function: |
|---------------------|---------------------------------------------------------------------------------------------|
| 0 [1...1000,000 ms] | This parameter enables for compensation in any fixed delay there may be in the touch probe. |

19-04 Control source

| Range: | Function: |
|-----------|-------------------------------------------------------------------------------------------------------|
| 0 [0...1] | Choose control source for pos. controller. Enter "0" for digital inputs or "1" for field-bus control. |

19-05 User APOS setting

| Range: | Function: |
|--------------------------------------|------------------------------------------------------------------------------------------------|
| 0 [-1,073,741,824 ... 1,073,741,824] | At power-up if FORCE HOME (par. 33-00) is "0" the actual position is equal the value set here. |

19-06 Error behaviour

| Option: | Function: |
|------------------------|------------------------------------------------------------------------------------------------------------------------------------------------------------------------------------------------------------------------------------------------------------------------------------------------------------------------------------------------------------------------------------------------------------------------------------------------------------------|
| [0] * Electronic brake | This parameter determines the behaviour of the drive after an error is detected. If "0" is selected the drive will ramp down to standstill with the shortest possible ramp (P3281). After achieving standstill it will activate the electronic brake according to the setting of COAST DELAY. If the drive is coasted at any point during ramp down (e.g. due to an OVER CURRENT trip) the drive will immediately activate the brake and coast the drive. |
| [1] Mechanical brake | If "1" is selected the drive will immediately activate the brake and coast the drive. |



The brake is always activated after an error situation (or quick stop) regardless of the AUTO BRAKE CTRL setting.

19-07 Error reset

| Option: | Function: |
|-----------------|----------------------------------------------------------------------------------------------------------------------------------------|
| [0] * No reset | The parameter automatically resets to "0" when the error is successfully cleared. |
| [1] Reset error | By setting this parameter to "1" it is possible to clear the error flag (provided that the reason for the error is not still present). |

19-08 Power-recovery

| Option: | Function: |
|---------------|-------------------------------------------------------------------------------------------------------------------------------------------------------------------------------------------------------------------------------------------------------------------------------------------------------------------------------------------------------------------------------------------------------------------------------------------------------------------------------------------------------------------------------------------------------------------------------------------------------------------------------------------------------------------------------------------------------------------------------------------------------------------|
| [0] disabled | When the power recovery function is disabled (0), it is not possible to drive the application by any means (neither jogging nor positioning) as long as the application is outside the HW or SW limits. The only way to recover from this situation is to move the application by hand. |
| [1] * enabled | When the power recovery function is activated (1) however it is possible to make a "partial reset" of the limit error (ERROR STATUS = 2/3/4/5) whereby it will be possible to use the jogging function to drive the application out of the HW or SW limit area. It is not possible to drive the application otherwise by means of homing, positioning or jogging (in the wrong direction), as long as the application is still within the HW or SW limit area. The "error occurred" output will remain high to indicate that these restrictions are in effect. As soon as the application is moved outside the HW or SW limit area the error is automatically cleared and the "error occurred" signal goes low to indicate that normal operation is now restored. |

19-09

Option:

[0] Disabled

Function:

When the automatic brake control function is disabled, the drive controls the application also at standstill.

[1] * Enabled

When the automatic brake control function is enabled, the electromechanical brake is automatically activated every time the application has been at standstill for a time period specified in parameter 19-12. This is especially useful in hoist applications where the motor could overheat if it has to deliver full torque at standstill for a prolonged period of time.

19-10 Coast delay

Range:

200 ms [0...1,000 ms]

Function:

Used in conjunction with the automatic brake control function. The coast delay is the delay after activating the electro-mechanical brake before disabling the controller and coasting the drive. Useful in hoisting applications where the load would otherwise have a tendency to drop a little after each stop because the activation of the brake is slower than the deactivation of the drive.

19-11 BRAKE DELAY

Range:

200 ms [0...1,000 ms]

Function:

Used in conjunction with the automatic brake control function. The brake delay is the delay after activating the control and magnetising the motor before the brake is deactivated. Useful in applications with (typically large) motors that take a longer time to be fully magnetised than the time it takes for the electro-mechanical brake to deactivate.

19-12 Hold delay

Range:

0 s [0...10,000 s]

Function:

Used in conjunction with the automatic brake control function. The hold delay is a waiting period in which the brake is not activated even though the application is at standstill. Useful in applications where a sequence of fast positioning commands is followed by longer standstill periods.

19-13 Brake wear limit

Range:

0 [0 (= disabled) ... 1,073,741,824 UU]

Function:

Setting a value higher than "0" (disabled) the drive defines an error situation ("Brake wear limit exceeded" – ERROR STATUS = 7) if the drive moves more than the number of UU specified in this parameter while the electronic brake is activated.

19-14 Motor/encoder gear nominator

| | |
|---------------|------------------------------------------------------------------------------------------------------------------------------------------------------------------------------------------------------------------------------------------------------------------------------------------------------------------------------------------------------------|
| Range: | Function: |
| 1 [1...1,000] | If the encoder is mounted on a gear where 5 revolutions of the motor correspond to 2 revolutions of the encoder, GEAR NUM should be set to "5" (the number of motor revolutions) and GEAR DEN should be set to "2" (the number of encoder revolutions). If the encoder is mounted directly on the motor shaft this parameter setting should remain at "1". |

19-15 Motor/encoder gear denominator

| | |
|---------------|-------------------------------------------------------------------------------------------------------------------------------------|
| Range: | Function: |
| 1 [1...1,000] | See the description of GEAR NUM. If the encoder is mounted directly on the motor shaft this parameter setting should remain at "1". |

19-16 Maximum jog velocity

| | |
|--------------------------------|-------------------------------------------------------------------------------------------------------------------------|
| Range: | Function: |
| 100 [1...999,999 ERPM] ERPM | The maximum speed allowed while jogging the application is specified in terms of Encoder Revolutions Per Minute (ERPM). |



NB!

This setting must never exceed a value that is approx. 5% lower than the value in par. 32-80.

19-17 Jog ramp time

| | |
|-------------------------------|------------------------------------------------------------------------------------------------------------------------------------------------------------------------------------------------------------------------------------|
| Range: | Function: |
| 5,000 [50...100,000 ms] ms | This parameter specifies both the ramp-up time as well as the ramp-down time used during jogging. The ramp time is defined as the time in milliseconds it would take to ramp from standstill to the maximum allowed velocity 3280. |

19-18 Jog Velocity Scaling

| | |
|---------------|-----------------------------------------------------------------|
| Range: | Function: |
| 0 [0...1] | If 1, the scale velocity will be scaled by MOT ENC GEAR NUM/DEN |

19-19 FFVEL auto-calculation

| | |
|-------------------|----------------------------------------------------------------------------------------------------------------------------|
| Option: | Function: |
| [0] * Disabled | |
| [1] FFVEL enabled | Setting this parameter to "1" will prompt the program to calculate the optimal setting of parameter velocity feed forward. |

- [2] FFVEL + PID enabled Setting this parameter to "2" will prompt the program to calculate the optimal setting of parameter velocity feed forward, proportional, derivative and integral factor.
 P3280 Maximum Velocity
 P3200 OR 3202 encoder type
 P3201 OR 3203 encoder resolution
 P1914 motor/encoder gear ratio numerator
 P1915 motor/encoder gear ratio denominator

**NB!**

If any one of these parameters are changed, prompt a recalculation, since the optimum value of the regulation parameters will have changed.

19-20 Factory reset

| Option: | Function: |
|----------------|---------------------------------------------------------------------------------------------------------------------------------|
| [0] * Disabled | The parameter automatically resets to "0" when the reset is successfully carried out. |
| [1] Enabled | By setting this parameter to "1" it is possible to reset all parameter values to default. This also resets all trajectory data. |

19-21 Link LCP input to index

| Option: | Function: |
|----------------|------------------------------------------------------------------------------------------------------------------------------------------------------------------------------------------------------------------------------------------------------|
| [0] * disabled | The function is deactivated when set to "0". This is necessary when programming a position number different from the one loaded into the PLC memory. |
| [1] * enabled | When activating this function (1) INDEX NUMBER will be automatically updated with the last position reference number that has been loaded into memory. This enables to operator to see what position reference is currently given by the PLC system. |

19-23 Index number

| Range: | Function: |
|-------------------------------------------|-----------------------------------------------------------------------------------------------------------------------------------------------------------------------------------------------------------------------------------------------------------------------------------------------------------------------------------------------------------------------|
| 0 [0 ... 31 0 ... 63 in fieldbus mode] | Specify which position data that should be displayed in par. 19-24 to par.19-28. Whenever this number is changed the current values of the Index Parameters are stored in memory under the previously specified index number. After that, the values of the index parameters are updated with the data stored in memory relevant to the newly specified index number. |

19-24 Index target position

| Range: | Function: |
|-----------------------------------------|---------------------------------------------------------------------------------------------------------------------------------------------------------------------------------------------------------------------------|
| 0 [-1,073,741,824 ... 1,073,741,824 UU] | The meaning of this parameter depends on the position type specified in TRAJECTORY TYPE. If TRAJECTORY TYPE = 0, the value of this parameter refers to an absolute position (relative to the fixed HOME position). |

If TRAJECTORY TYPE = 1 and the last position was obtained through jogging, the value of this parameter is a position relative to that position. If the last position was reached as a result of a positioning command, then the value of this parameter specifies a position relative to the last target position (whether it was reached or not).

If TRAJECTORY TYPE = 2 the application will move in the positive direction until a touch probe position is defined. If a touch probe position is already defined the application will move directly to that position.

A touch probe position is defined as the position at which the "touch probe switch" input goes high plus the value of TARGET POSITION.

A touch probe position is cleared by a high signal on the "reset touch probe position" input. The output "Touch probe position locked" is high if a touch probe position is defined. If TRAJECTORY TYPE = 3 the application will move in the negative direction until a touch probe position is defined. If a touch probe position is already defined the application will move directly to that position.

**NB!**

This parameter is automatically updated depending on INDEX NUMBER.

19-25 Index ramp up time

Range:

5,000 [50....100,000 ms]

Function:

This setting is relevant during positioning with the current trajectory index. The index ramp up time is defined as the time in milliseconds it would take to ramp from standstill to the maximum allowed velocity (P3280).

**NB!**

This parameter is automatically updated depending on INDEX NUMBER.

19-26 Index ramp down time

Range:

5,000 [50....100,000 ms]

Function:

This setting is relevant during positioning with the current trajectory index. The index ramp down time is defined as the time in milliseconds it would take to ramp from the maximum allowed velocity (P3280) to standstill.

**NB!**

This parameter is automatically updated depending on INDEX NUMBER.

19-27 Index maximum velocity

| Range: | Function: |
|--------------------------------|--------------------------------------------------------------------------------|
| 100 [1...999.999 ERPM] ERPM | This setting is relevant during positioning with the current trajectory index. |

**NB!**

This parameter is automatically updated depending on INDEX NUMBER. The setting should never exceed a value that is approx. 5% lower than the value calculated in P32-80.

19-28 Index trajectory type

| Option: | Function: |
|--------------------------|-----------|
| [0] * absolute | |
| [1] Relative | |
| [2] Touch probe positive | |
| [3] Touch probe negative | |

The function of this parameter setting is described under TARGET POSITION.

**NB!**

This parameter is automatically updated depending on INDEX NUMBER.

19-29 Parameter save

| Option: | Function: |
|-----------------|----------------------------------------------------------------------------------------------------------------------------------------------------------------------------------------------------------------------|
| [0] * No action | This parameter automatically resets to "0" when the data is successfully stored. |
| [1] SAVE EEPROM | Trajectory data is not automatically stored in EEPROM and will thus not automatically be available after power-down and power-up. To permanently store changes made to trajectory this parameter must be set to "1". |

19-30 Main screen setup save

| Option: | Function: |
|-----------------|------------------------------------------------------------------------------------------------------------------------------------------------------------------------------------------------------------------------------|
| [0] * No action | Mains screen setup is not automatically stored in EEPROM and will thus not automatically be available after power-down and power-up. This parameter automatically resets to "0" when the data is successfully stored. |
| [1] SAVE EEPROM | To permanently store changes made to the main screen setup this parameter must be set to "1". |

19-91 Software version

| | |
|---------------|----------------------------------------------------------------------------------------------------|
| Range: | Function: |
| 110 [110] | The text in this parameter shows the current version number of the Positioning Controller program. |

19-92 New Index

| | |
|------------------------------------------|--------------------------------|
| Range: | Function: |
| 0 [0...31 0...63 in fieldbus mode] | Currently latched index number |

19-93 Error status

| | |
|-------------------------------------------------------------------------------------------------------------------------------------------------------------------------------------------------------------------------------------------------------------------------------------------|----------------------------------------------------------------------------|
| Option: | Function: |
| [0] * 0 = OK 1 = Homing needed 2 = Pos. HW limit 3 = Neg. HW limit 4 = Pos. SW limit 5 = Neg. SW limit 6 = VLT not running 7 = Brake wear limit 8 = Quick stop 9 = PID error too big 12= Rev. operation 13= Fwd. operation 92= Encoder hardware error | READ-ONLY PARAMETER: The current error code is displayed in this parameter |

32-00 Incremental Signal Type

| | |
|---------------------|---------------------------------------------------------------------------------------------------------|
| Option: | Function: |
| [0] * None | Set up the incremental encoder type here. If an absolute Type is used, this Parameter MUST be set to 0! |
| [1] RS422 | |
| [2] Sinusoidal 1Vpp | |



NB!

When switching from a setting of absolute encoder to a setting of incremental encoder, the home flag is automatically cleared. A homing procedure afterwards is necessary before any positioning commands can be executed.

32-01 Encoder resolution

| | |
|----------------------------------|---------------------------------------------------------------------------------------------------------------------------------------|
| Range: | Function: |
| 1024 [1...1,000,000 ps.* ses] | pul- If an incremental encoder is used its resolution must be entered here in pulses per revolution (not quad-counts per revolution). |

32-02 Absolute Protocol

| Option: | Function: |
|---------------------|--------------------------------------------------------------------------------------------------------------------------------------------------------------------------------------------------------------------------------------------------------------------------------------------------------------------------------------------------------------------------------------------------------------------------------------------------------------------------------------------------------------------------------------------------------------------------------------------------------------------------|
| [0] * None | Set up the absolute encoder type here. If an absolute Type is used, Parameter 3200 MUST be set to 0! If you select any absolute encoder the home flag is instantly set high, thus no homing is required preceding a positioning command. A possible leap in the position data can be detected if it is larger than the encoder resolution/2. The correction is made by means of an artificial position value which is calculated from the last velocity. If the error continues for more than 100 read-outs (> 100 ms), there will be no further correction which will then lead to a tolerated position error exceeded. |
| [4] SSI | |
| [5] SSI with filter | |

32-03 Encoder resolution

| Range: | Function: |
|----------------------------------|------------------------------------------------------------------------------------------------------------------------------------|
| 1024 [1...1,000,000 ps.* ses] | pul- If an absolute encoder is used its resolution must be entered here in pulses per revolution (not quad-counts per revolution). |

32-10 Positive Direction

| Option: | Function: |
|-------------------------|-----------------------------------------------------------------------------------------------------------------------------------------------------------------------------------------------------------------------------------------------------------|
| [1] * No action | This parameter is used to specify which encoder direction is considered positive. When changing this setting the current actual position (P3450) will also change sign. 1 = standard, position is counting positive when the drive is running forward. |
| [2] Reference Reversed | 2 = as "1", but with opposite sign of the reference to the drive. This can be used as alternative to swapping two motor phases if direction of motor rotation is wrong. |
| [3] User units reversed | 3= position is counting negative when the drive is running forward. |
| [4] Uu and Ref reversed | 4 = as "3", but with opposite sign of the reference to the drive. This can be used as alternative to swapping two motor phases if direction of motor rotation is wrong. |

32-11 User unit denominator

| Range: | Function: |
|--------------------------|----------------------------------------------------------------------------------------------------------------------------------------------------------------------------------|
| 1* [1 ... 1,073,741,823] | Par. 32-12 and par. 32-11 together define the ratio between User Units (UU) and quad-counts (QC). The setting of this parameter is illustrated in the description of par. 32-11. |



The target positions stored in memory is defined according to the settings of par. 32-12/par. 32-11, so changing the par. 32-12/par. 32-11 ratio might require that up to 32 positions must be reprogrammed to achieve the same result as before the change.

32-12 User unit numerator

Range:

1* [1 ... 1,073,741,823]

Function:

Par. 32-12 and par. 32-11 together define the ratio between User Units (UU) and quad-counts (QC). This parameter can be illustrated with the following example:

By measurement it has been determined that 1000 mm of travel correspond to 16345 QC (quad-counts). Now instead of defining the target positions in QC but rather in mm, the setting of par. 32-12 must be 16345, and the setting of par. 32-11 must be 1000.



NB!

The target positions stored in memory is defined according to the settings of par. 32-12/par. 32-11, so changing the par. 32-12/par. 32-11 ratio might require that up to 32 positions must be reprogrammed to achieve the same result as before the change.

32-60 Proportional gain

Range:

30* [1...100,000]

Function:

The proportional gain is the factor that is multiplied with the PID tracking error to produce the proportional part of the output frequency. The higher the setting of this parameter the "harder" is the resulting control.



NB!

Too high a setting of this parameter will cause the controller to become unstable.

32-61 Derivative gain

Range:

0* [1...100,000]

Function:

The derivative gain is the factor that is multiplied with the change in the PID tracking error to produce the derivative part of the output frequency. The higher the setting of this parameter the "harder" is the resulting control. The derivative gain has best effect if the encoder is mounted directly on the motor and an encoder with good resolution (4096 pulses/rev) is used.



NB!

Too high a setting of this parameter will cause the controller to become unstable.

32-62 Integral gain

Range:

0* [1...100,000]

Function:

The integral gain is the factor that is multiplied with the integrated PID tracking error to produce the integral part of the output frequency. The main function of the integral part is to provide zero steady-state tracking error. The higher the setting, the faster the application will reach a zero steady-state tracking error. The dynamic tracking error however increases with increasing setting of this parameter.

NB!

Too high a setting of this parameter will cause the controller to become unstable.

32-63 Limit integral part

Range:

1,000* [0...100,000]

Function:

Here it is possible to clamp the integral part of the PID output. A setting of 1000 corresponds to 100% of the maximum allowed reference specified in parameter 303.

32-64 Limit PID output

Range:

1,000* [0...100,000]

Function:

Here it is possible to clamp the total output of the PID controller. A setting of 1000 corresponds to 100 % of the maximum allowed reference specified in parameter 303.

32-65 Feed Forward Velocity Gain

Range:

0* [0...100,000]

Function:

The velocity feed-forward gain is the factor that is multiplied with the set-point (desired trajectory) velocity to produce the feed-forward part of the output frequency. The function of the feed-forward part is to provide a fast (and fairly accurate) starting point for the calculation of the output frequency.

NB!

To get the fastest and most stable controller response this parameter should be set optimally. For this purpose parameter 19-19 gives access to a function that automatically calculates the optimal setting of this parameter.

32-66 Feed-forward acceleration gain

Range:

0* [0...100,000]

Function:

The acceleration feed-forward gain is the factor that is multiplied with the set-point acceleration to produce the feed-forward part of the output frequency.

32-67 Maximum tolerated PID error

Range:

20,000 [1...1,073,741,823
qc* qc]

Function:

The PID track error is defined as the difference between the internal controller set-point and the actual position. The better tuning of the PID controller (par. 32-60 to 32-66) the lesser the PID track error.

At every sample time the current track error is compared with the setting of par. 32-67. It is defined as an error situation ("PID track error too big" - par. 19-93 = 9) if the track error is bigger than the setting of par. 32-67. After tuning the PID controller optimally this parameter should be set to a value approx. 50 % larger than the maximum observed value of par. 34-56.

NB!

The unit is quad-counts (QC) not user units (UU).

32-69 PID sample interval

Range:

1 ms* [1...1000 ms]

Function:

The sampling frequency of the controller can be adjusted in this parameter. Normally, the fastest possible setting (1 ms) is preferable, but in cases with low resolution of the feedback signal it is a good idea to set this parameter at a slightly higher value.

32-80 Maximum allowed velocity

Range:

1,500 [1 ... 100,000 ERPM]
ERPM
1*

Function:

When performing a FFVEL autocalculation, the maximum velocity allowed is calculated on the basis of par. 303, par.19-14, par. 19-15 and the result is presented in this parameter.

32-81 Quick ramp time

Range:

1,000 [50...3600000 ms]
ms*

Function:

The quick ramp time is defined as the time to ramp down from the maximum velocity to standstill. The quick ramp time is used when the quick stop function is activated or an error has occurred.

32-82 Ramp type

Option:

[0] * Linear

Function:

This parameter MUST be set to 0 for the Positioning Controller.

[1] * S-Ramp

33-00 Force HOME

| Option: | Function: |
|-----------------------|----------------------------------------------------------------------------------------------------|
| [0] * Home not forced | |
| [1] * Home forced | If this parameter is set to 1, homing has to be carried out before any positioning can take place. |

33-01 Home offset

| Range: | Function: |
|-------------------------------------------------|-----------------------------------------------------------------------------------------------------------------------------------------------------------------|
| 0 UU* [-1,073,741,824, ... 1,073,741,823 UU] | This parameter defines an offset to the "zero" (HOME) position. Any change in this setting will immediately affect the actual position displayed in par. 34-50. |

33-02 Home ramp time

| Range: | Function: |
|-------------------|-----------------------------------------------------------------------------------------------------------------------------------------------|
| 10 ms* [1...1000] | The home ramp time is defined as the time in milliseconds it would take to ramp from stand-still to the maximum allowed velocity par. 32-80). |

33-03 Home velocity

| Range: | Function: |
|--------------------------------------------------------------|--------------------------------------------------------------------------------------------------------------------------------------------------|
| 100 ERPm* [-(value in P3280)... (value in P3280) ERPm] | The home velocity is entered here. Notice that the sign of the velocity determines the direction in which the homing sequence will be performed. |

33-04 Home type

| Option: | Function: |
|---------|-------------------------------------------------------------------------------------------------------------------------------------------------------------------------------------------------------------------------------------------------------------|
| [0] * | The drive moves to the reference switch (Input 4) with home velocity (P3303), then reverses and slowly (at 30% of home velocity) leaves the switch, subsequently moves to the next index pulse. The HOME position is defined as that index position. |
| [1] * | Like "0" but without the search for the index position. Instead the HOME position is defined as the position at which the reference switch goes low. After defining the HOME position the drive is then ramped down with the home ramp (P3302) and stopped. |
| [2] * | Like "0" but without reversing before leaving the reference switch. Rather the movement is slowly continued in the same direction out of the switch. |
| [3] * | Like "1" but without the search for the index position. Instead the HOME position is defined as the position at which the reference switch goes low. After defining the HOME position the drive is then ramped down with the home ramp (P3302) and stopped. |

33-41 Negative software limit

| | |
|------------------------------------------------------|---------------------------------------------------------------------------------------------------------------------------------------------------------------------------------------------------------------------------|
| Range: | Function: |
| -500,0 [-1,073,741,824 ... 00 * 1,073,741,823 UU] | If the actual position (par. 34-50) goes below the value specified in this parameter an error situation is defined (par. 19-93 = 5) and handled according to the setting of the "Error behaviour" parameter (par. 19-06). |

33-42 Positive software limit

| | |
|------------------------------------------------------|------------------------------------------------------------------------------------------------------------------------------------------------------------------------------------------------------------------------|
| Range: | Function: |
| -500,0 [-1,073,741,824 ... 00 * 1,073,741,823 UU] | If the actual position (par. 34-50) exceeds the value specified in this parameter an error situation is defined (par. 19-93 = 4) and handled according to the setting of the "Error behaviour" parameter (par. 19-06). |

33-43 Negative SW limit active

| | |
|---------------|-----------------------------------------------------------------------------------------------------------------------------|
| Range: | Function: |
| 0* [0...1] | Enter "0" to disable negative software limit switch. This should be done only when not positioning within two fixed limits. |

33-44 Positive SW limit active

| | |
|---------------|-----------------------------------------------------------------------------------------------------------------------------|
| Range: | Function: |
| 0* [0...1] | Enter "0" to disable positive software limit switch. This should be done only when not positioning within two fixed limits. |



NB!

Either both or none of the SW limits must be active. Only activating one border is not valid. When Limits have been activated or deactivated, switch the drive off and on.

33-45 Actual position

| | |
|---------------------------------------------|---------------------------------------------------------------------------------------------------------|
| Range: | Function: |
| 0* [-2,000,000,000 ... 2,000,000,000 UU] | READ-ONLY PARAMETER: This parameter displays the latest position obtained from the feedback encoder. |

33-47 Target position window

| | |
|------------------------------------|----------------------------------------------------------------------------------------------------------------------------------------------------------------------------------------------------------------------------------------------------------------------------------------------------------------------------------------------------------------------------------------------------------------------------------------------------------------------------------------------------------------------------------------------|
| Range: | Function: |
| 0* [0 UU (< P726) ... 10000 UU] | During a positioning sequence the "Referenced position reached" output (X59 2) is set according to this parameter. If the setting of this parameter is "0" then the "Referenced position reached" output goes high immediately when the internal PID target position is equal to the requested target position. If the setting of this parameter is larger than "0" i.e. "200" then the "Referenced position reached" output goes high when the actual position (par. 34-50) is within ± 200 UU of the requested target position. |

34-40 Actual inputs

Range:

000000 [000000000000
 000000 111111111111]
 *

Function:

/ During a positioning sequence the "Referenced position reached" output (X59 2) is set according to this parameter.

READ-ONLY PARAMETER:

This parameter displays the last read status of the digital input on the option card (X57). The status of the digital inputs on the VLT5000 control card is accessible via par. 16-60.

34-56 PID tracking error

Range:

0* [-2,000,000,000 ...
 2,000,000,000 UU]

Function:

During a positioning sequence the "Referenced position reached" output (X59 2) is set according to this parameter.

READ-ONLY PARAMETER:

The current PID tracking error is displayed in this parameter in user units.

5. Application Examples

5.1. Application examples

The drawing below shows a layout of a pallet conveyor system. Loaded pallets are coming from four different product lines via the pallet inlet conveyors. Each pallet must be transported from one of the four inlet conveyors to one of the two outlet conveyors. To do this a movable pallet conveyor cart is used.

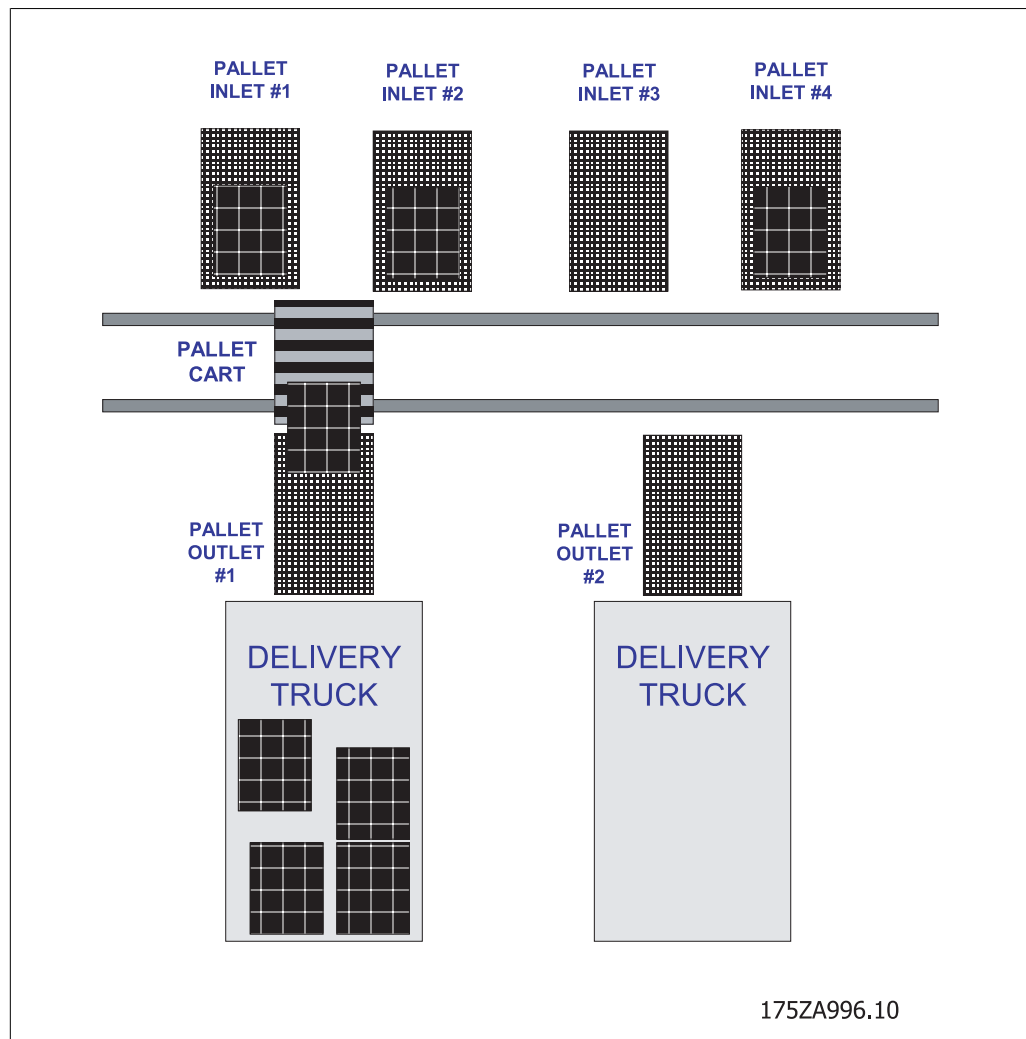

A typical work process could be:

1. Moving the (empty) pallet conveyor cart to pallet inlet no. 1 to pick up a loaded pallet.
2. Waiting until the pallet is successfully transferred to the cart.
3. Moving to pallet outlet no. 2.
4. Waiting until the pallet is successfully transferred to the outlet conveyor and so on...

5.1.1. Wiring diagram

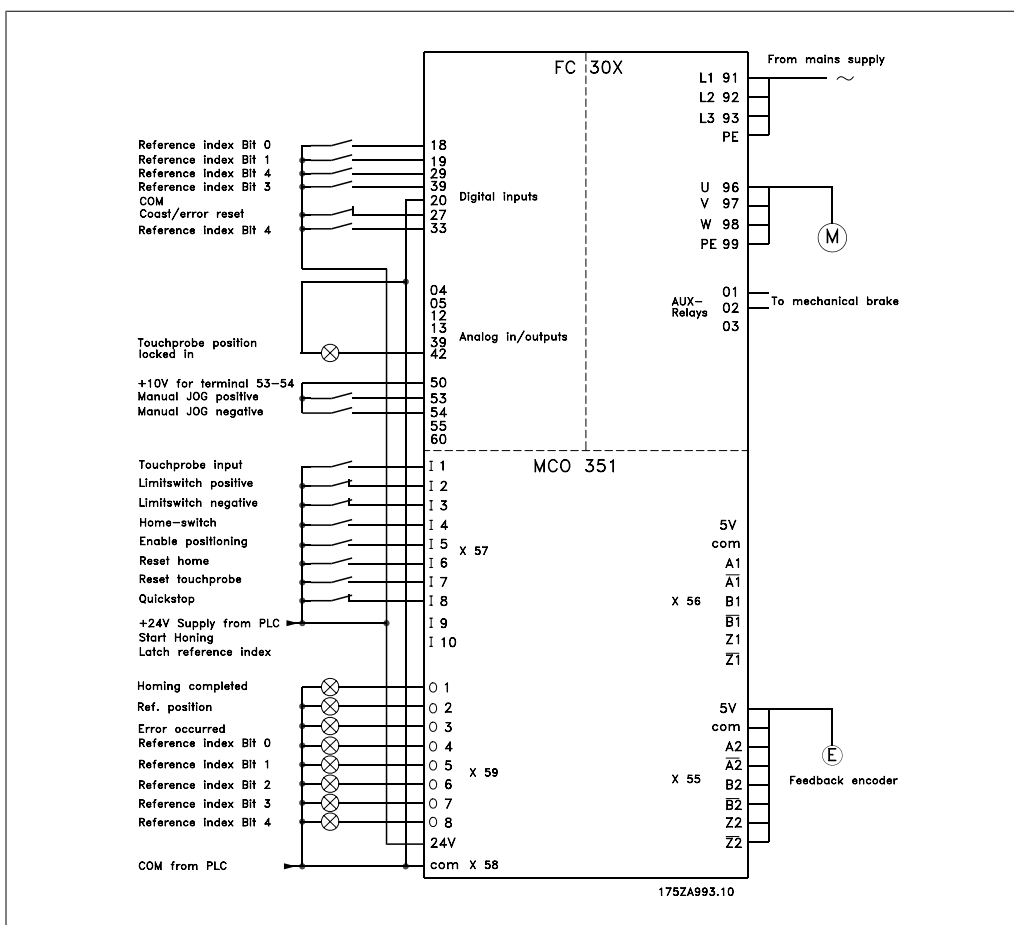

NB! Please note that input 29 is not available in FC 301. This means that only 16 positions can be selected via digital inputs in FC 301.

5.1.2. Basic Setup

First, check the motor connection. Please be aware that the mechanical brake control cannot be trusted during this basic setup, therefore control brake externally from the option until setup is finished. Also ensure that the motor can rotate freely without causing damage or injury to personal.

1. Remove all signals to inputs . Only Input 27(coast), 18 (q-stop), 13 (HW limit) and I2 (HW limit) must be connected and high.
2. Select "Off" Mode
3. Input the motor name plate data in P120-125 and activate the "Automatic Motor Adaptation" function in P129.
4. Press the [Hand On] button on the FC control panel and wait for the AMA to be completed.
5. Goto "Hand on" mode and set the frequency for a low positive value, for example +3 Hz in the reference value, please note that motor should now rotate.
6. If the motor rotates in the wrong (negative) direction then exchange the motor phases.

7. When using an incremental encoder:
Setup Incremental Signal Type par. 32-00 to the type needed. Set up the resolution of the encoder in par. 32-01.
When using an absolute encoder:
Setup Incremental Signal Type par. 32-00 to "0", Absolute Protocol P2302 to your type of encoder and Absolute Resolution par. 32-03 matching the resolution of your encoder. Set up databit and clock settings for absolute encoder in parameters 32-05 through 32-08.
8. Press the [STATUS] button on the LCP. Now the following values appear in the upper line of the display: RPM and Actual Position.
9. Rotate the slave drive motor shaft manually in the positive direction. Now the display should show an ascending count of the actual position.
10. If the count is descending with an incremental encoder, exchange the feedback encoder track A by B and A/ by B/. If there is no counting in the display then check the wiring of the encoder. When you have tested the encoders and the wiring of motor and encoders, continue as follows:
11. Select "Auto On" mode on the FC control panel.
12. Reset any error by toggling input 27.
Now you come to the test run:
13. Drive the application back and forth by closing the contacts on terminal 53 (positive direction) or terminal 54 (negative direction). Watch the PID track error via P3456 display during these tests.
Now you can optimise the controller:
14. Optimise the Feed forward velocity P3265 by following the procedure described in the parameter list for the FFVEL auto-calculation function.
15. If the track error after entering "2" in parameter P3456 is within specification, when jogging, there is no reason to optimise any further, move to step 21.
16. Increase the P-portion P3260. After each change you should make a test run to find the right setting. If the drive becomes unstable or if a message is given about over-voltage or over-current, then reduce the value in parameter P3260 to about 70-80% of the set value.
17. Increase the other PID parameters P3261 (if needed) by following the same approach. Read the description concerning these parameters in the parameter list.

5.1.3. Parameter Settings

Now determine the parameter settings fitting this application. The following list of parameters can be determined right away:

| Parameter no. | |
|----------------|----------------------------------------------------|
| 32-61 to 62-67 | Determined during optimising of the PID controller |
| 32-10 | Default ("1") |
| 32-00 | Incremental encoder used ("1") |
| 32-01 | Encoder resolution ("4096") |
| 32-82 | Trapeze ramps must be used ("0") |
| 19-14 | Default (encoder mounted directly on motor) ("1") |
| 19-15 | Default (encoder mounted directly on motor) ("1") |
| 19-16 | Default ("100") |
| 19-17 | Default ("1500") |
| 33-01 | Default ("0") |
| 19-02 | Default ("0") |
| 19-03 | Default ("0") |

5.1.4. Timing of the Electromechanical brake (par. 19-10 to 19-12)

If the application is not equipped with an electromechanical brake, par. 19-10 to 19-12 are not very important. Then, however, it is very important to set par. 19-09 to "0" to enable the drive also at standstill.

This application is equipped with mechanical brakes to allow it to stop rapidly even if the drive is somehow prevented from stopping the motor (damaged motor cables, damaged or short-circuited motor, inverter overload and so on).

Par. 19-10 to 19-12 is provided to time the interaction between the mechanical brake and the drive. A description of these parameters can be found in the parameter list above. In this application the default values of COAST DELAY and BRAKE DELAY is used (200 ms) but the HOLD DELAY setting is changed to 30 seconds to minimise wear of the brake.

5.1.5. Setting of par. 32-11 and 32-12

Distances are measured in quad-counts (QC) but defined in millimetres. Therefore, it is necessary to measure how many QC correspond to how many millimetres. To do this the cart is first moved as far to the left as possible by activating the "Manual jog negative" input (terminal 54). The position is then marked on the application and the corresponding value of par. 34-50 is noted. Then the cart is moved as far to the right as possible by activating the "Manual jog positive" input (terminal 53). The travelled distance in mm is now measured from the position of the mark to the position of the cart. Likewise the distance in QC is calculated by subtracting the current value of P3450 from the noted value of P3450. In this example it is measured that 871380 QC correspond to 4000 mm.

To prevent eventually overflow the parameters values are a factor 10 smaller than the measured QC and mm so par. 32-12 is set to "87138" and par. 32-11 is set to "400". Positions will now be displayed and entered in millimetres. Settings like par. 32-12 set to "43569" and par. 32-11 set to "200" will also give the positions in millimetres.

5.1.6. Setting for the Homing Procedure (par. 33-00 to 33-04)

The HOME ramp setting (par. 33-02) is reduced to the lowest allowable setting to get the fastest HOMING procedure possible. The HOME velocity setting, however, should never be very high to enable a precise result of the homing procedure, and because the exact position is not known during homing, it is not advisable to go with a very high velocity for safety reasons. The default setting of par. 33-03 at 100 encoder revolutions per minute (approx. 1/15th of the max. velocity)

is therefore maintained in this application. The default homing type defined in par. 33-04 is also maintained.

The resulting homing sequence is illustrated below.

5.1.7. Programming positions (par. 19-23 to 19-28)

The program positions the conveyor cart in front of the various inlets and outlets. Different acceleration and deceleration is allowed between the different positions. An empty pallet cart can be accelerated as fast as possible while this is not allowed when transporting a fully loaded pallet.

Different settings for each position are available because every position is programmed

The different positions are programmed using par. 19-23 to 19-28 as interface. First, the application must be homed to get at fixed reference for measuring (and entering) the positions.

When this is done the first position is programmed:

- Par. 19-23 is set to "1" either directly or by using the digital inputs and the "link" functionality of par. 19-21.1
- The position is programmed in P1924 either directly on the LCP or by using the "TEACH-IN" functionality (simply use the jog inputs (54, 53) to drive the application to the desired position, then press the [Back] and [Cancel] buttons to store that position in memory).
1
- The individual ramp and velocity settings for this position is specified in P1925-P1927.1
- For trajectory type "absolute" is selected in par. 19-28 set to ("0"). 1

The following table shows the complete list of settings for each of the 6 target positions.

| 19-23 | 19-24 | 19-25 | 19-26 | 19-27 | 19-28 |
|-------|--------|-------|-------|-------|-------|
| 1 | 40000 | 900 | 900 | 500 | 0 |
| 2 | 80000 | 2000 | 2000 | 500 | 0 |
| 3 | 150000 | 900 | 900 | 500 | 0 |
| 4 | 220000 | 900 | 900 | 500 | 0 |
| 5 | 260000 | 2000 | 2000 | 500 | 0 |
| 6 | 330000 | 900 | 900 | 500 | 0 |

5.1.8. Software Limits (par. 33-41 to 33-44)

The software limits are placed just in front of the hardware limit switches with a distance to the hardware limit switches that allows for the cart to be stopped with the shortest allowable ramp before the HW limit switch is activated.

The settings are: par. 33-41 = "370000" and
par. 33-42 = "-10000".

5.1.9. Setting par. 32-81 and 19-06

If the pallet cart is transporting a loaded pallet and travelling at its top speed, it is not allowed to simply activate the electromechanical brake (all the products on the pallet would be scattered across to floor because of the deceleration). So if a "safety cage" or other safety device is opened and the "quick stop" input is activated, the drive should ramp down with the appropriate ramp and then activate the safety brake. This functionality is achieved by setting par. 19-06 to "0" and tuning par. 32-81 to the lowest allowable setting.

5.1.10. Other Settings

The maximum PID track error was brought down to approximately +/- 100 QC during the optimising sequence described above. Therefore, it is an indication of an error, if the PID track error should suddenly grow larger than approximately +/- 200 QC. Thus par. 32-67 *Maximum tolerated PID error* is set at "200".

The maximum tolerated travel of the brake before replacement is estimated at 4 mm so *Brake wear limit* is set to "4".

If the application for some reason should ever go into the not allowed area beyond the SW limits it should be possible to bring the application back into the allowed area by resetting the limit error and using the jog inputs. This is achieved by setting par. 19-08 *Power-recovery* to "1". The allowed position tolerance is defined to be +/- 10 mm in this application so P3347 *Target position window* is set to "10".

6. Troubleshooting

6.1. Frequently Asked questions

Q1:

When I have a "PID TRACK ERROR TOO BIG" error (par. 798="9"), the inverter also trips on ALARM 13 (OVER CURRENT).

A1:

- a) Check that the velocity setting (par. 723 for jogging and par. 738/par. 742 for positioning) is at least 5% lower than the maximum allowed velocity calculated in par. 799. Either lower the velocity (par. 723 or par. 742) setting or raise the maximum allowed velocity (par. 799) by setting a higher value of par. 205 - please see Q2.
- b) The quick stop ramp time (par. 719) could be too short. Try to increase the setting.

Q2:

How do I adjust the maximum allowed velocity in par. 32-80?

A2:

You need to raise the setting of par. 303. Doing this will also affect the performance of the parameters par. 32-60 to 32-66. Smaller changes to par. 303 may not have any noticeable effect on most of these parameters but par. 32-65 should always be recalculated using the auto-calculation function par. 19-19.

Q3:

The inverter frequently trips on ALARM 7 (DC LINK OVERVOLTAGE) while ramping down.

A3:

- a) Use a higher ramp time setting (par. 719 for "quick stop", par. 724 for jogging and par. 738/par. 741 for positioning).
- b) If a lower ramp time is required a brake resistor should be installed.

Q4:

The inverter frequently trips on ALARM 13 (OVER CURRENT) while ramping up

A4:

- a) The ramp settings may require too much torque. Try to determine which operation ("quick stop", manual move or positioning) caused the trip, and then set the corresponding ramp time (par. 719 for "quick stop", par. 724 for jogging and par 738/par. 741 for positioning) with a higher ramp time setting.
- b) The PID controller settings may be unstable – re-optimize the PID controller parameters (par. 702-709).

Q5:

The correct target position is reached, but the PID tracking error (P797) is too big while the drive moves.

A5:

Harder settings of the PID controller may be required – re-optimize the PID controller parameters (par. 702-709).

Q6:

The option sometimes seems to forget changes to trajectory data.

A6:

Changes to trajectory data values are not stored after power-down unless par. 777 (STORE DATA) is activated before power-down.

6.2. Error Messages

All messages are shown in P789 in the VLT 5000 LCP display. You can find detailed information, additional notes on possible causes of errors as well as tips for clearing errors in the following section.

P19-93 - 0: Status OK. No errors detected.

Meaning

No errors detected.

P19-93 - 1: Homing needed

Meaning

The user has issued a positioning command to a certain position while the home position is not defined.

NOTE: The error must be cleared and a homing sequence successfully completed before the next position command is issued to the application.

P19-93 - 2: Positive hardware limit exceeded

Meaning

The positive hardware switch input has been activated.

Causes

The application has hit the positive limit marker switch. Alternatively, the connection to the limit switch has been lost or the limit switch is defective.

P19-93 - 3: Negative hardware limit exceeded

Meaning

The negative hardware switch input is activated.

Causes

The application has hit the negative limit marker switch. Alternatively, the connection to the limit switch has been lost or the limit switch is defective

P19-93 - 4: Positive software limit exceededMeaning

A motor command will cause / has caused the software limit switch to be activated. The maximum limit is specified in P744.

Note

Before the error can be cleared the application must be moved back from the limit. If "power recovery" is enabled in P736, this can be done through an error reset and a negative jog (input 54).

P19-93 - 5: Negative software limit exceededMeaning

A motor command will cause / has caused the software limit switch to be activated. The minimum limit is specified in P745.

Note

Before the error can be cleared the application must be moved back from the limit. If "power recovery" is enabled in P736 this can be done through an error reset and a positive jog (input 53).

P19-93 - 6: VLT not runningMeaning

The motor was not magnetised in a situation where it should have been. The electromechanical brake is immediately activated in this case regardless of the settings in P718 and P725.

Causes

While the motor was holding/driving the load, the drive either tripped, connection to terminal 27 was lost, or the [STOP] button was pressed on the LCP.

P19-93 - 7: Brake wear limit exceededMeaning

This error message is given if the drive has moved more than the allowed number of user units specified in P735 *while* the electronic brake was activated.

Causes

The mechanical brake is worn and should be replaced in the near future or the limit specified in P735 is too low.

P19-93 - 8: Quick stop input activatedMeaning

The quick stop input has been activated. As a safety precaution of the electromechanical brake is activated according to the setting of P725 and the drive is coasted regardless of the setting of P715. Normal operation is resumed if the error is cleared.

P19-93 - 9: Controller (PID) tracking error too bigMeaning

The difference between the desired set-point position and the actual position read via the encoder feedback has exceeded the limit specified in P726.

Causes**Several reasons may exist:**

1. The encoder is not properly connected. Check the encoder connection.
2. The encoder is counting positive in the wrong direction. Switch A and B channels if necessary.
3. The PID controller settings are not properly optimised. Follow the instructions for optimising.
4. The limit specified in P726 may be too low.

P19-93 - 12: Reverse operation prohibited

Meaning

The drives have been operated in reverse direction while this was not allowed according to the setting of P734.

P19-93 - 13: Forward operation prohibited

Meaning

The drives have been operated in forward direction while this was not allowed according to the setting of P734.

P19-93 - 92: Error from encoder monitoring

Meaning

Open or short circuit in accordance with the displayed LED. An error will be displayed even if no encoder is connected and the monitor is active (P3209 = 1).

6.3. Glossary of Key Terms

Incremental encoder

This is an encoder system that picks up the speed and the direction of rotation and transmits on the appropriate configuration. The number of tracks, and thus the number of signals, indicate the properties of the encoder system. There are single-track systems that deliver a pulse signal dependent on the speed as well as a fixed direction signal. Dual-track systems deliver two pulse signals that are offset 90 degrees. By evaluating the two tracks, the direction signal is also obtained. Three-track encoders deliver, as well as the two tracks of the dual-track encoder, an additional "zero-track". This emits a signal when the zeros transit is passed through.

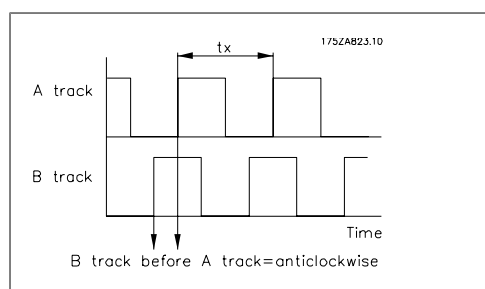

Illustration 6.1: Incremental Encoder Signals

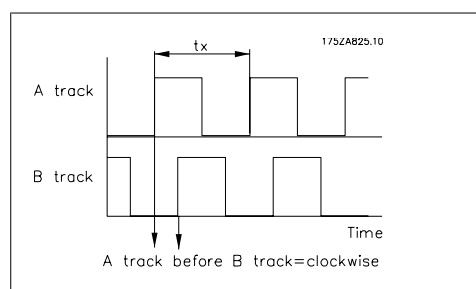

Illustration 6.1: Incremental Encoder Signals

Quad counts

Through edge detection, a quadrupling of the increments is produced by both tracks (A/B) of the incremental encoder. This improves the resolution.

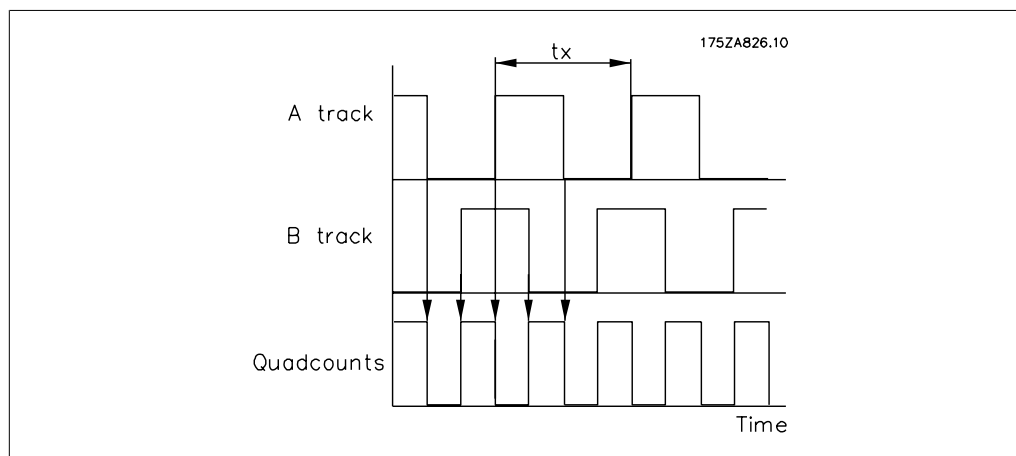

Illustration 6.1: Derivation of quad counts

Absolute value encoder

This is a special form of encoder, as it indicates not only the speed and direction of rotation but also the absolute physical position. This is communicated via transfer of the position in parallel form or in the form of a telegram in serial form. Absolute value encoders also come in two versions: Single-Turn encoders supply an absolute position via a specific quantity, or via a freely-definable number of rotations.

ERPM

The speed is defined in relation to the RPM of the encoder. To underline this the term "encoder revolutions per minute" is chosen as unit.

AMA

Automatic Motor Adaptation - function in P129.

Motor/encoder gear ratio

Since the encoder is not necessarily mounted on the motor itself, the relationship between the nominal motor speed in RPM and the nominal encoder speed in ERPM must be specified.

Track error

The PID track error is defined as the difference between the internal controller set-point and the actual position. The track error is specified in UU and is displayed in P3456. **NOTE!** The maximum tolerated PID error is entered in P3267 in QC.

6

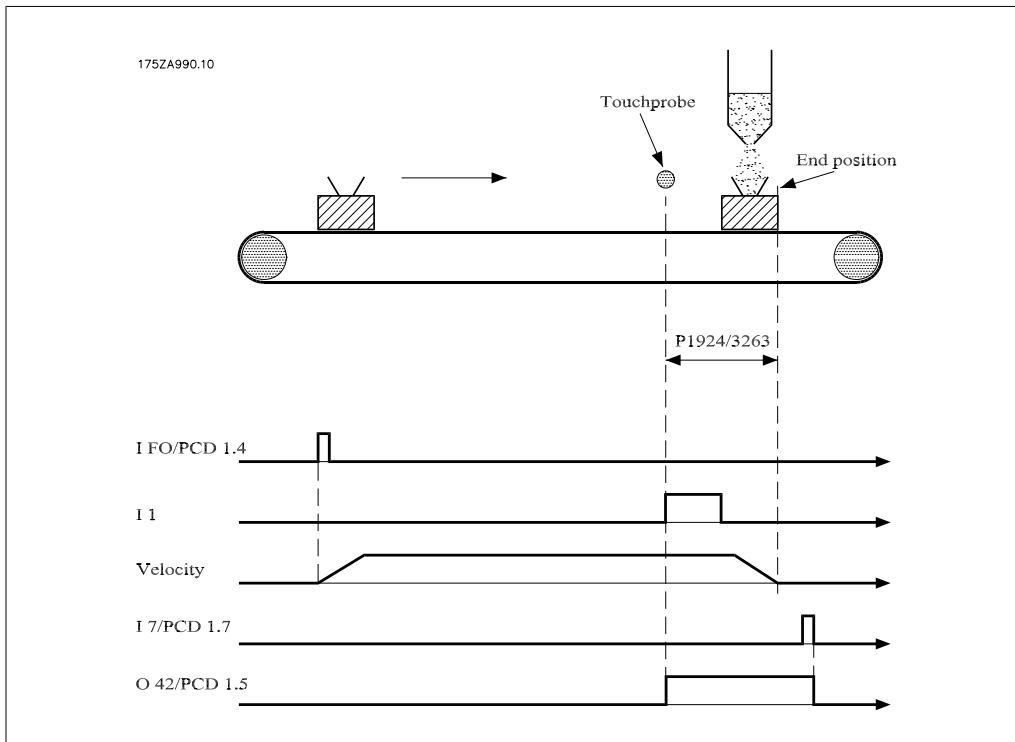

Input 10 is the latch reference index input in digital control mode. PCD 1.4 is the latch reference index input in fieldbus control mode.

Input 1 is the touch probe input.

Input 7 is the reset touch probe input in digital control mode. PCD 1.7 is the reset touch probe input in fieldbus control mode.

NB!

A delay in the touch probe sensor will make the target position drift. This means the target position will become larger than stated in parameter 1924. To compensate for this please specify a delay value in parameter 1903. Only a constant delay can be compensated for, and not a variable delay.

Index

A

| | |
|-------------------------------------|----|
| Absolute Protocol | 26 |
| Actual Inputs | 32 |
| Adjust The Maximum Allowed Velocity | 41 |
| Alarm 13 | 41 |
| Alarm 7 | 41 |
| An Application Example | 35 |
| Approvals | 3 |
| Automatic Brake Control | 20 |

B

| | |
|----------------|----|
| Basic Setup | 36 |
| Block Reversal | 19 |

C

| | |
|----------------|----|
| Control Source | 19 |
|----------------|----|

D

| | |
|----------------------|----|
| Dc Link Overvoltage | 41 |
| Digital Inputs: | 11 |
| Digital Outputs | 11 |
| Disposal Instruction | 3 |

E

| | |
|-----------------------|----|
| Earth Leakage Current | 4 |
| Encoder Monitor | 10 |
| Encoder Resolution | 26 |
| Error Behaviour | 20 |
| Error Reset | 20 |

F

| | |
|--------------------------------|----|
| Factory Reset | 23 |
| Feed Forward Velocity Gain | 29 |
| Feed-forward Acceleration Gain | 29 |
| Ffvel Auto-calculation | 22 |
| Fieldbus Control Signals | 18 |
| Fieldbus Interface | 17 |
| Fieldbus Status Signals | 18 |
| Force Home | 30 |

G

| | |
|-----------------|---|
| General Warning | 5 |
|-----------------|---|

H

| | |
|----------------|----|
| Hardware | 9 |
| Hold Delay | 21 |
| Home Offset | 31 |
| Home Ramp Time | 31 |
| Home Type | 31 |
| Home Velocity | 31 |

I

| | |
|-------------------------|----|
| Incremental Signal Type | 26 |
| Index Maximum Velocity | 25 |
| Index Number | 23 |
| Introduction | |

J

| | |
|---------------|----|
| Jog Ramp Time | 22 |
|---------------|----|

L

| | |
|---------------------|----|
| Leakage Current | 5 |
| Limit Integral Part | 29 |
| Limit Pid Output | 29 |

M

| | |
|--------------------------------|----|
| Maximum Jog Velocity | 22 |
| Maximum Tolerated Pid Error | 30 |
| Motor Overload Protection | 4 |
| Motor/encoder Gear Denominator | 22 |
| Motor/encoder Gear Nominator | 21 |

N

| | |
|-------------------------|----|
| Negative Software Limit | 31 |
|-------------------------|----|

O

| | |
|-----------------------|----|
| Option Card Layout | 11 |
| Option Card Terminals | 9 |
| Option Card X57 | 15 |

P

| | |
|-------------------------|----|
| Pallet Conveyor System | 35 |
| Pid Sample Interval | 30 |
| Pid Track Error Too Big | 41 |
| Pid Tracking Error | 33 |
| Positive Direction | 27 |
| Positive Software Limit | 32 |
| Power-recovery | 20 |
| Proportional Gain | 28 |

Q

| | |
|-----------------|----|
| Quick Ramp Time | 30 |
|-----------------|----|

R

| | |
|-------------------------|----|
| Ramp Down Time | 24 |
| Ramp Type | 30 |
| Ramp Up Time | 24 |
| Repair Work | 5 |
| Residual Current Device | 5 |

S

| | |
|---------------------|----|
| Safe Stop | 5 |
| Safety Instructions | 4 |
| Safety Regulations | 3 |
| Sample Interval | 30 |
| Software Version | 4 |
| Store Data | 42 |
| Supply Voltages | 11 |
| Symbols | 3 |

T

| | |
|-------------------|----|
| Technical Data | 9 |
| Terminals | 9 |
| Touch Probe Delay | 19 |
| Trajectory Type | 25 |

| | |
|----------------------------------|--------|
| Troubleshooting | 41 |
| U | |
| Unintended Start | 5 |
| User Apos Setting | 19 |
| User Unit Denominator | 27 |
| User Unit Numerator | 28 |
| V | |
| Vlt Control Card Terminals | 9 |
| Voltage Level | 11, 12 |
| W | |
| Wiring Diagram | 36 |