

Contents

1 How to Read the Instruction Manual	1-1
Approvals	1-1
Symbols	1-2
Abbreviations	1-3
2 Safety Instructions and General Warning	2-1
High Voltage	2-1
Safety Instructions	2-2
Avoid Unintended Start	2-2
Safe Stop	2-3
IT Line Power	2-6
3 How to Install	3-1
Pre-installation	3-1
Planning the Installation Site	3-1
Receiving the Adjustable Frequency Drive	3-1
Transportation and Unpacking	3-2
Lifting	3-3
Mechanical Dimensions	3-5
Rated Power	3-12
Mechanical Installation	3-14
Terminal Locations - Frame size D	3-16
Terminal Locations - Frame size E	3-18
Terminal Locations - Frame size F	3-22
Cooling and Airflow	3-26
Field Installation of Options	3-32
Installation of Duct Cooling Kit in Rittal Enclosures	3-32
Installation of Top-only Duct Cooling Kit	3-33
Installation of Top and Bottom Covers for Rittal Enclosures	3-34
Installation of Top and Bottom Covers	3-34
Outside Installation/ NEMA 3R Kit for Rittal Enclosures	3-35
Outside Installation /NEMA 3R Kit of Industrial Enclosures	3-36
Installation of IP00s D3 & D4 Terminal Cover	3-36
Installation of IP00s D3, D4, & E2 Cable Clamp Bracket	3-36
Installation on Pedestal	3-37
Installation of Line Power Shield for Adjustable Frequency Drives	3-38
Installation of Input Plate Options	3-38

Installation of D1, D2, D3, & D4 Loadshare Option	3-39
Frame Size F Panel Options	3-39
Electrical Installation	3-42
Power Connections	3-42
AC Line Input Connection	3-58
Fuses	3-59
Motor Insulation	3-63
Motor Bearing Currents	3-64
Control Cable Routing	3-66
Electrical Installation, Control Terminals	3-68
Connection Examples	3-69
Start/Stop	3-69
Pulse Start/Stop	3-69
Electrical Installation, Control Cables	3-71
Switches S201, S202, and S801	3-73
Final Set-Up and Test	3-74
Additional Connections	3-76
Mechanical Brake Control	3-76
Motor Thermal Protection	3-77
4 How to Program	4-1
The Graphical and Numerical LCP	4-1
How to Program on the Graphical LCP	4-1
How to Program on the Numerical Local Control Panel	4-2
Quick Set-up	4-4
Parameter Lists	4-9
5 General Specifications	5-1
6 Warnings and Alarms	6-1
Status Messages	6-1
Warnings/Alarm Messages	6-1
7 Index	7-1

1 How to Read the Instruction Manual

1.1.1 How to Read the Instruction Manual

The adjustable frequency drive is designed to provide high shaft performance on electrical motors. Please read this manual carefully for proper use. Incorrect handling of the adjustable frequency drive may cause improper operation of the adjustable frequency drive or related equipment, shorten lifetime or cause other problems.

This Instruction Manual will help you get started as well as install, program, and troubleshoot your adjustable frequency drive.

Chapter 1, **How to Read this Instruction Manual**, introduces the manual and informs you of the approvals, symbols and abbreviations used in this literature.

Chapter 2, **Safety Instructions and General Warnings**, contains instructions on how to handle the adjustable frequency drive correctly.

Chapter 3, **How to Install**, guides you through mechanical and technical installation.

Chapter 4, **How to Program**, shows you how to operate and program the adjustable frequency drive via the Local Control Panel.

Chapter 5, **General Specifications**, contains technical data about the adjustable frequency drive.

Chapter 6, **Warnings and Alarms**, assists you in solving problems that may occur when using the adjustable frequency drive.

Available literature for FC 300

- The VLT AutomationDrive Instruction Manual - High Power, MG.33.UX.YY provides the necessary information for getting the drive up and running.
- The VLT AutomationDrive Design Guide MG.33.BX.YY contains all technical information about the drive and customer design and applications.
- The VLT AutomationDrive Programming Guide MG.33.MX.YY provides information on how to program and includes complete parameter descriptions.
- The VLT AutomationDrive Profibus Instruction Manual MG.33.CX.YY provides the information required for controlling, monitoring and programming the drive via a Profibus serial communication bus.
- The VLT AutomationDrive DeviceNet Instruction Manual MG.33.DX.YY provides the information required for controlling, monitoring and programming the drive via a DeviceNet serial communication bus.

X = Revision number

YY = Language code

Danfoss technical literature is also available online at www.danfoss.com/drives.

1.1.2 Approvals



1

1.1.3 Symbols

Symbols used in this Instruction Manual.

	NOTE! Indicates something to be noted by the reader.
---	--

	Indicates a general warning.
---	------------------------------

	Indicates a high-voltage warning.
---	-----------------------------------

*	Indicates a default setting
---	-----------------------------

1.1.4 Abbreviations

Alternating current	AC
American wire gauge	AWG
Ampere/AMP	A
Automatic Motor Adaptation	AMA
Current limit	I _{LIM}
Degrees Celsius	°C
Direct current	DC
Drive Dependent	D-TYPE
Electro Magnetic Compatibility	EMC
Electronic Thermal Relay	ETR
Adjustable Frequency Drive	FC
Gram	g
Hertz	Hz
Kilohertz	kHz
Local Control Panel	LCP
Meter	m
Millihenry Inductance	mH
Milliampere	mA
Millisecond	ms
Minute	min
Motion Control Tool	MCT
Nanofarad	nF
Newton Meters	Nm
Nominal motor current	I _{M,N}
Nominal motor frequency	f _{M,N}
Nominal motor power	P _{M,N}
Nominal motor voltage	U _{M,N}
Parameter	par.
Protective Extra Low Voltage	PELV
Printed Circuit Board	PCB
Rated Inverter Output Current	I _{INV}
Revolutions Per Minute	RPM
Regenerative terminals	Regen
Second	s
Synchronous Motor Speed	n _s
Torque limit	T _{LIM}
Volt	V
The maximum output current	I _{VLT,MAX}
The rated output current supplied by the adjustable frequency drive	I _{VLT,N}

2 Safety Instructions and General Warning

2.1.1 Disposal Instructions



Equipment containing electrical components may not be disposed of together with domestic waste. It must be separately collected with electrical and electronic waste according to local and currently valid legislation.



Caution

The adjustable frequency drive DC link capacitors remain charged after power has been disconnected. To avoid the electrical shock hazard, disconnect the adjustable frequency drive from line power before carrying out maintenance. Before servicing the adjustable frequency drive, wait the minimum amount of time indicated below:

	380–500 V	125–275 hp [90–200 kW]	20 minutes
		350–1075 hp [250 – 800 kW]	40 minutes
	525–690 V	50–450 hp [37–315 kW]	20 minutes
		500–1600 hp [355–1200 kW]	30 minutes

VLT AutomationDrive
Instruction Manual
Software version: 5.5x

This Instruction Manual can be used for all VLT AutomationDrive adjustable frequency drives with software version 5.5x. The software version number can be seen from par. 15-43 *Software Version*.

2.1.2 High Voltage



The voltage of the adjustable frequency drive is dangerous whenever the adjustable frequency drive is connected to line power. Incorrect installation or operation of the motor or adjustable frequency drive may cause damage to the equipment, serious personal injury or death. The instructions in this manual must therefore be observed, in addition to applicable local and national rules and safety regulations.



Installation at high altitudes

380–500 V: At altitudes higher than 10,000 ft [3 km], please contact Danfoss regarding PELV.
 525–690 V: At altitudes higher than 6,666 ft [2 km], please contact Danfoss regarding PELV.

2.1.3 Safety Instructions

- Make sure the adjustable frequency drive is properly grounded.
- Protect users against supply voltage.
- Protect the motor against overloading in accordance with national and local regulations.
- Motor overload protection is not included in the default settings. To add this function, set par. 1-90 *Motor Thermal Protection* to value *ETR trip* or *ETR warning*. For the North American market: ETR functions provide class 20 motor overload protection, in accordance with NEC.
- The ground leakage current exceeds 3.5 mA.
- The [OFF] key is not a safety switch. It does not disconnect the adjustable frequency drive from line power.

2.1.4 General Warning



Warning:

Touching the electrical parts may be fatal - even after the equipment has been disconnected from line power. Also make sure that other voltage inputs have been disconnected, such as load sharing (linkage of DC intermediate circuit), as well as the motor connection for kinetic backup. When using the adjustable frequency drive: wait at least 40 minutes. Shorter time is allowed only if indicated on the nameplate for the specific unit.



Leakage Current

The ground leakage current from the adjustable frequency drive exceeds 3.5 mA. To ensure that the ground cable has a good mechanical connection to the ground connection (terminal 95), the cable cross-section must be at least 0.016 in² [10 mm²] or 2 rated ground wires terminated separately. For proper grounding for EMC, see section *Grounding* in the *How to Install* chapter.

Residual Current Device

This product can cause a DC current in the protective conductor. Where a residual current device (RCD) is used for extra protection, only an RCD of Type B (time delayed) shall be used on the supply side of this product. See also RCD Application Note MN.90.Gx.02 (x=version number).

Protective grounding of the adjustable frequency drive and the use of RCDs must always follow national and local regulations.

2.1.5 Before Commencing Repair Work

1. Disconnect the adjustable frequency drive from line power.
2. Disconnect DC bus terminals 88 and 89 from load share applications
3. Wait for the discharge of the DC link. See period of time on the warning label.
4. Remove motor cable

2.1.6 Avoid Unintended Start

While the adjustable frequency drive is connected to line power, the motor can be started/stopped using digital commands, bus commands, references or via the Local Control Panel (LCP):

- Disconnect the adjustable frequency drive from line power whenever personal safety considerations make it necessary to avoid an unintended start.
- To avoid an unintended starts, always activate the [OFF] key before changing parameters.
- An electronic fault, temporary overload, a fault in the line power supply, or lost motor connection may cause a stopped motor to start. The adjustable frequency drive with safe stop provides protection against unintended start, if Safe Stop Terminal 37 is deactivated or disconnected.

2.1.7 Safe Stop

The FC 302 can perform the safety function *Safe Torque Off* (As defined by draft CD IEC 61800-5-2) or *Stop Category 0* (as defined in EN 60204-1).

It is designed and approved suitable for the requirements of Safety Category 3 in EN 954-1. This functionality is called Safe Stop. The information and instructions of the Instruction Manual are not sufficient for a correct and safe use of the Safe Stop functionality! In order to install and use the safe stop function in accordance with the requirements of Safety Category 3 in EN 954-1, the related information and instructions of the FC 300 Design Guide MG. 33.BX.YY must be followed! The information and instructions of the Instruction Manual are not sufficient for a correct and safe use of the safe stop functionality!

2

Prüf- und Zertifizierungsstelle
im BG-PRÜFZERT



BGIA
Berufsgenossenschaftliches
Institut für Arbeitsschutz

Hauptverband der gewerblichen
Berufsgenossenschaften

Translation

In any case, the German
original shall prevail.

Type Test Certificate

05 06004

No. of certificate

Name and address of the
holder of the certificate:
(customer) Danfoss Drives A/S, Ulnaes 1
DK-6300 Graasten, Dänemark

Name and address of the
manufacturer: Danfoss Drives A/S, Ulnaes 1
DK-6300 Graasten, Dänemark

Ref. of customer:

Ref. of Test and Certification Body:
Apf/Köh VE-Nr. 2003 23220

Date of Issue:
13.04.2005

Product designation: Frequency converter with integrated safety functions

Type: VLT® Automation Drive FC 302

Intended purpose: Implementation of safety function „Safe Stop“

Testing based on: EN 954-1, 1997-03,
DKE AK 226.03, 1998-06,
EN ISO 13849-2; 2003-12,
EN 61800-3, 2001-02,
EN 61800-5-1, 2003-09,

Test certificate: No.: 2003 23220 from 13.04.2005

Remarks: The presented types of the frequency converter FC 302 meet the requirements laid down in the test bases.
With correct wiring a category 3 according to DIN EN 954-1 is reached for the safety function.

The type tested complies with the provisions laid down in the directive 98/37/EC (Machinery).

Further conditions are laid down in the Rules of Procedure for Testing and Certification of April 2004.

Head of certification body

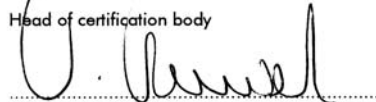

(Prof. Dr. rer. nat. Dietmar Reinert)

Certification officer



(Dipl.-Ing. R. Apfeld)

PZB10E
01.05



Postal address:
53754 Sankt Augustin

Office:
Alte Heerstraße 111
53757 Sankt Augustin

Phone: 0 22 41/2 31-02
Fax: 0 22 41/2 31-22 34

130BA373.11

2.1.8 Safe Stop Installation

To carry out an installation of a Category 0 Stop (EN60204) in conformity with Safety Category 3 (EN954-1), follow these instructions:

1. The bridge (jumper) between Terminal 37 and 24 V DC must be removed. Cutting or breaking the jumper is not sufficient. Remove it entirely to avoid short-circuiting. See jumper on illustration.
2. Connect terminal 37 to 24 V DC by a short-circuit-protected cable. The 24 V DC voltage supply must be interruptible by an EN954-1 category 3 circuit interrupt device. If the interrupt device and the adjustable frequency drive are placed in the same installation panel, you can use a non-shielded cable instead of a shielded one.

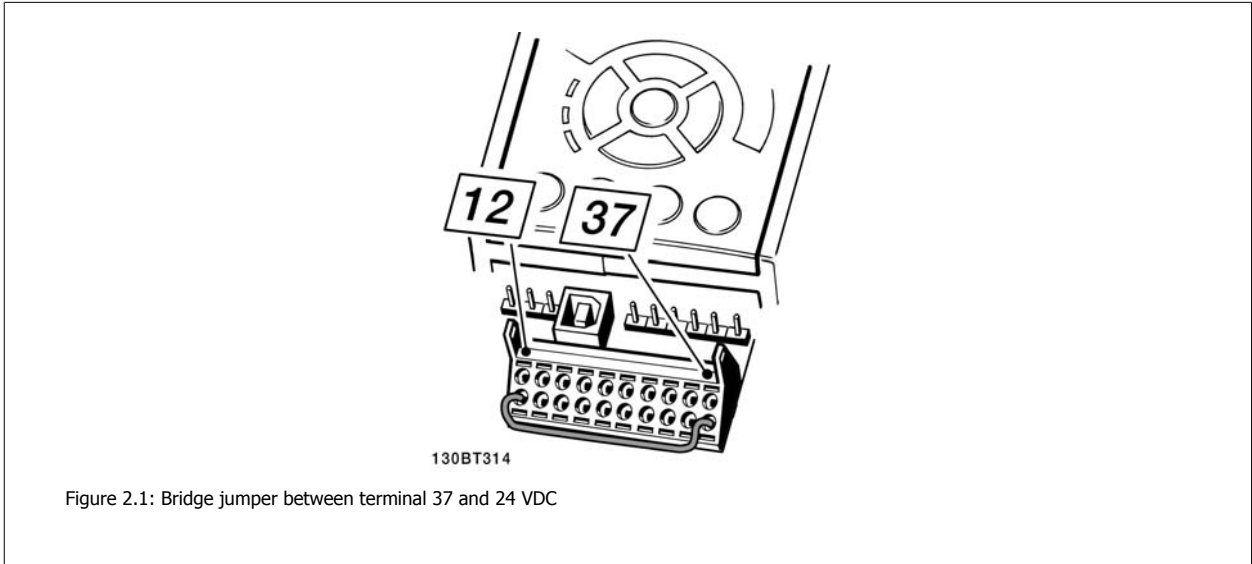

The illustration below shows a Stopping Category 0 (EN 60204-1) with safety Category 3 (EN 954-1). The circuit interruption is caused by an opening door contact. The illustration also shows how to connect a non-safety-related hardware coast.

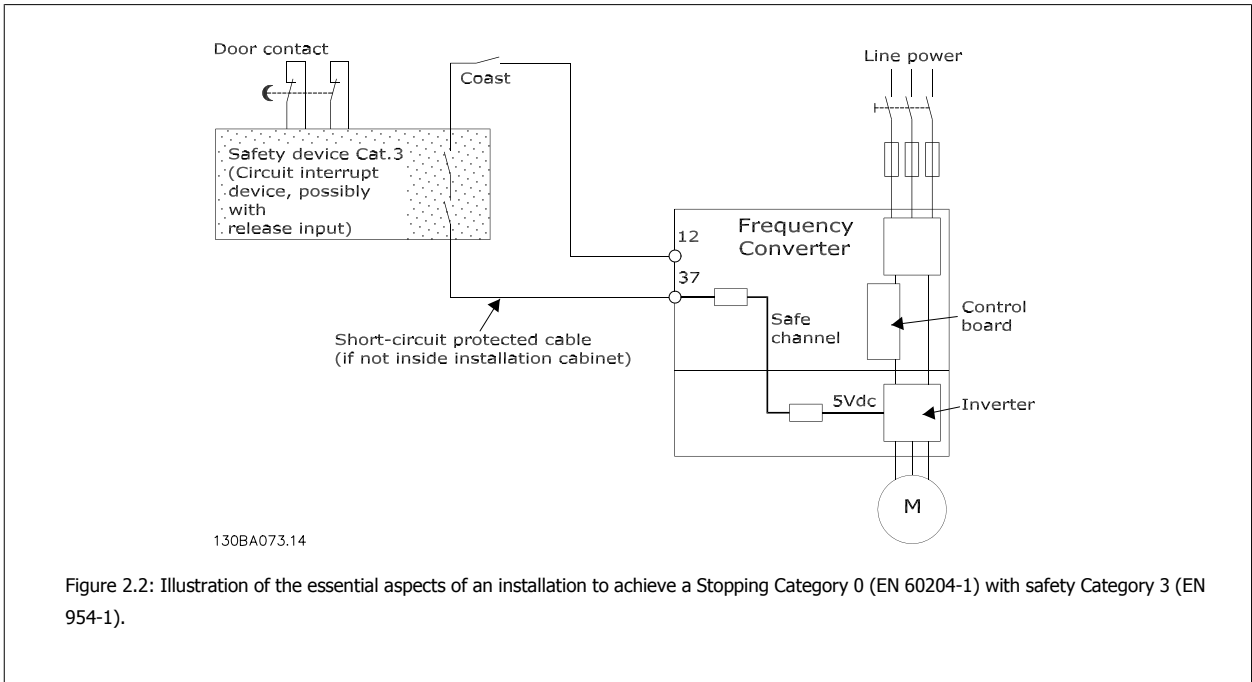

2.1.9 IT Line Power

2

Par. 14-50 *RFI 1* can be used to disconnect the internal RFI capacitors from the RFI filter to ground in the 380–500 V adjustable frequency drives. If this is done, it will reduce the RFI performance to A2 level. For the 525–690 V adjustable frequency drives, par. 14-50 *RFI 1* has no function. The RFI switch cannot be opened.

3 How to Install

3.1 Pre-installation

3.1.1 Planning the Installation Site



NOTE!

Before performing the installation, it is important to plan the installation of the adjustable frequency drive. Neglecting this may result in extra work during and after installation.

3

Select the best possible operation site by considering the following (see details on the following pages and in the respective Design Guides):

- Ambient operating temperature
- Installation method
- How to cool the unit
- Position of the adjustable frequency drive.
- Cable routing
- Ensure the power source supplies the correct voltage and necessary current.
- Ensure that the motor current rating is within the maximum current from the adjustable frequency drive.
- If the adjustable frequency drive is without built-in fuses, ensure that the external fuses are rated correctly.

3.1.2 Receiving the Adjustable Frequency Drive

When receiving the adjustable frequency drive, make sure that the packaging is intact, and look for any damage that might have occurred to the unit during transport. If damage has occurred, immediately contact the shipping company to make a damage claim.

3.1.3 Transportation and Unpacking

Before unpacking the adjustable frequency drive, it is recommended to unload it as close as possible to the final installation site. Remove the box and handle the adjustable frequency drive on the pallet, as long as possible.

**NOTE!**

The card box cover contains a drilling master for the mounting holes in the D frames. For the E size, please refer to section *Mechanical Dimensions* later in this chapter.

3

Figure 3.1: Mounting Template

3.1.4 Lifting

Always lift the adjustable frequency drive using the dedicated lifting holes. For all D and E2 (IP00) enclosures, use a bar to avoid bending the lifting holes of the adjustable frequency drive.

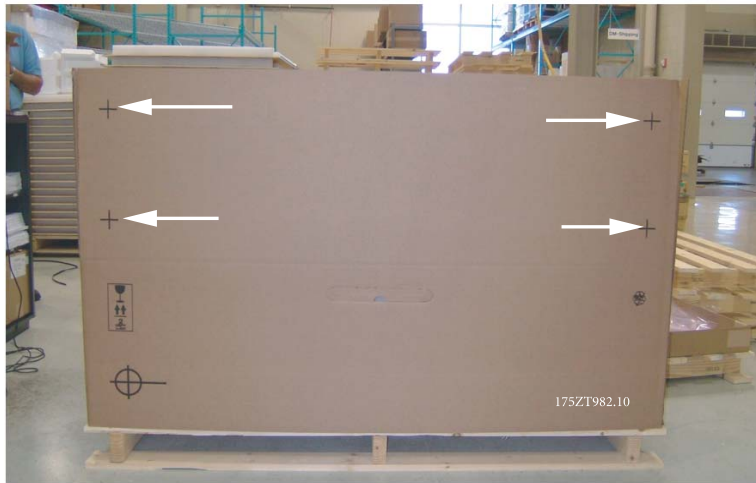
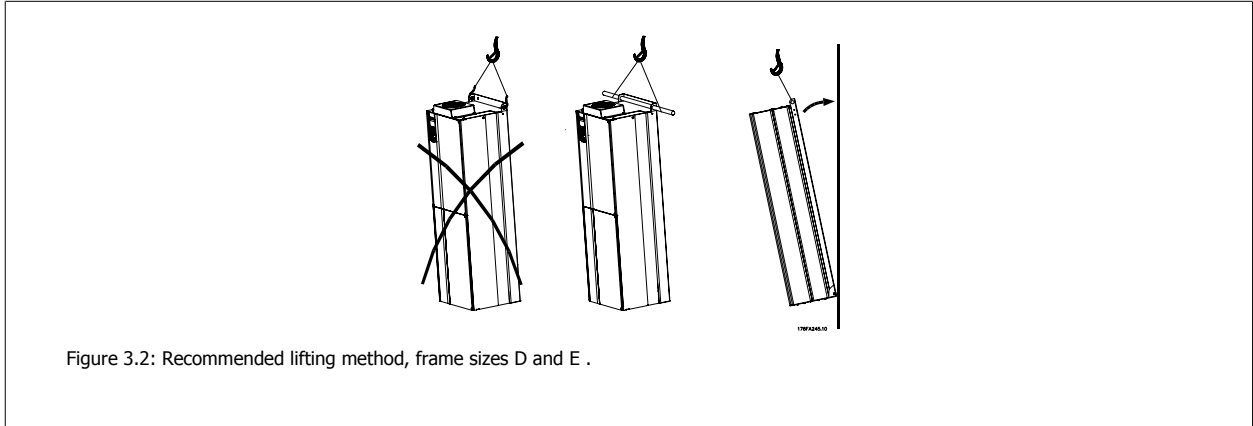

Figure 3.2: Recommended lifting method, frame sizes D and E .



NOTE!

The lifting bar must be able to handle the weight of the adjustable frequency drive. See *Mechanical Dimensions* for the weight of the different frame sizes. Maximum diameter for bar is 1 in [2.5 cm]. The angle from the top of the drive to the lifting cable should be 60° C or greater.

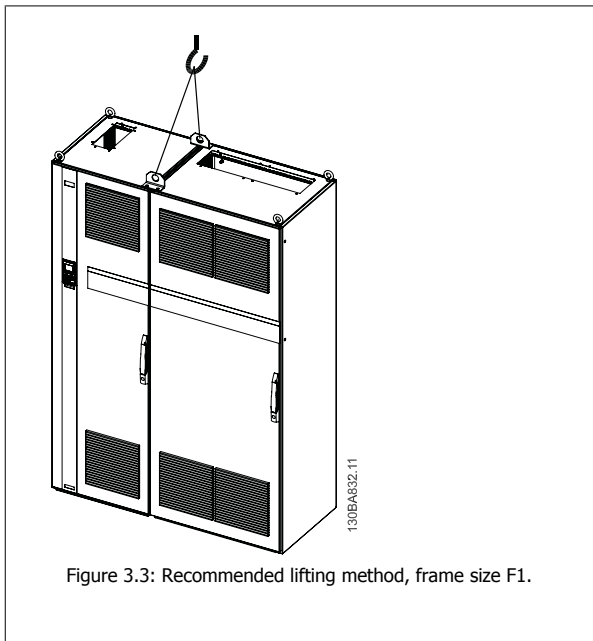

Figure 3.3: Recommended lifting method, frame size F1.

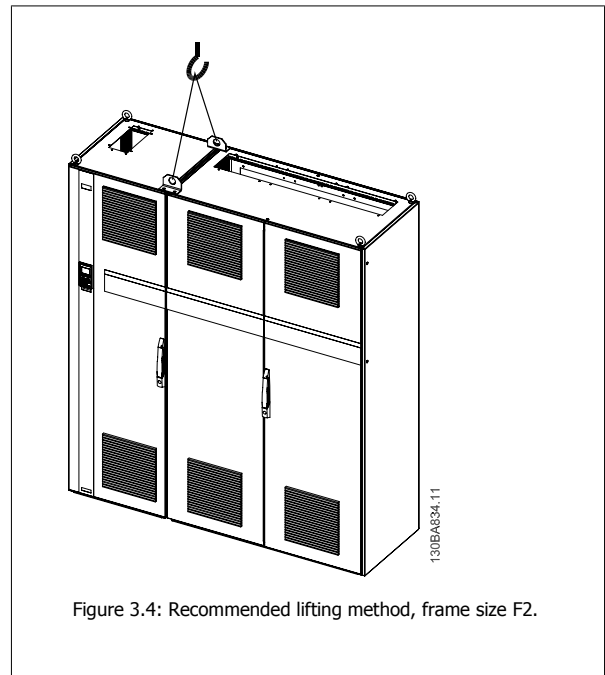

Figure 3.4: Recommended lifting method, frame size F2.

3

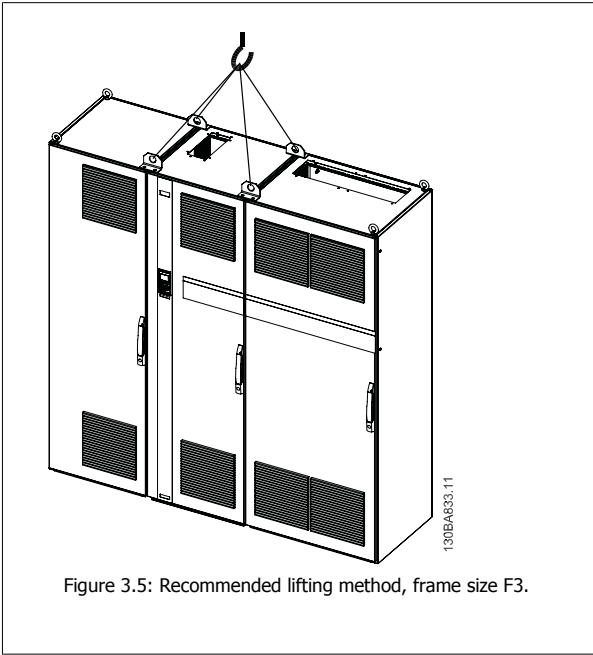

Figure 3.5: Recommended lifting method, frame size F3.

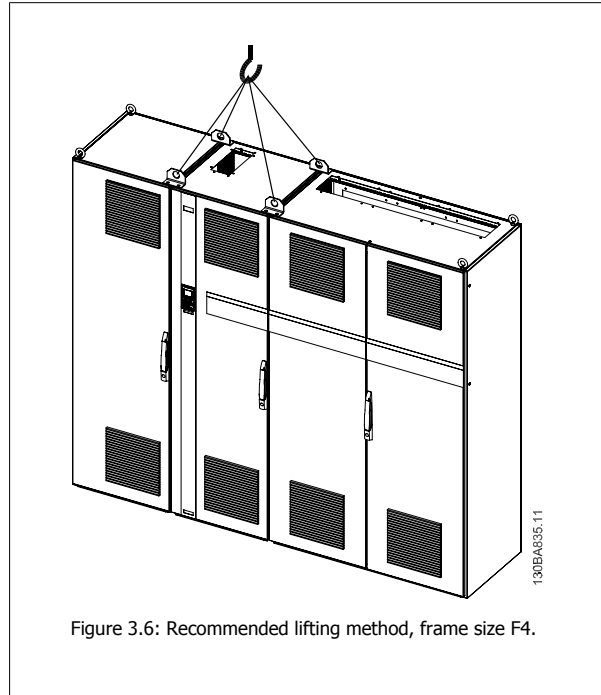

Figure 3.6: Recommended lifting method, frame size F4.



NOTE!

Note the plinth is provided in the same packaging as the adjustable frequency drive but is not attached to frame sizes F1-F4 during shipment. The plinth is required to allow airflow to the drive to provide proper cooling. The F frames should be positioned on top of the plinth in the final installation location. The angle from the top of the drive to the lifting cable should be 60° C or greater.

3.1.5 Mechanical Dimensions

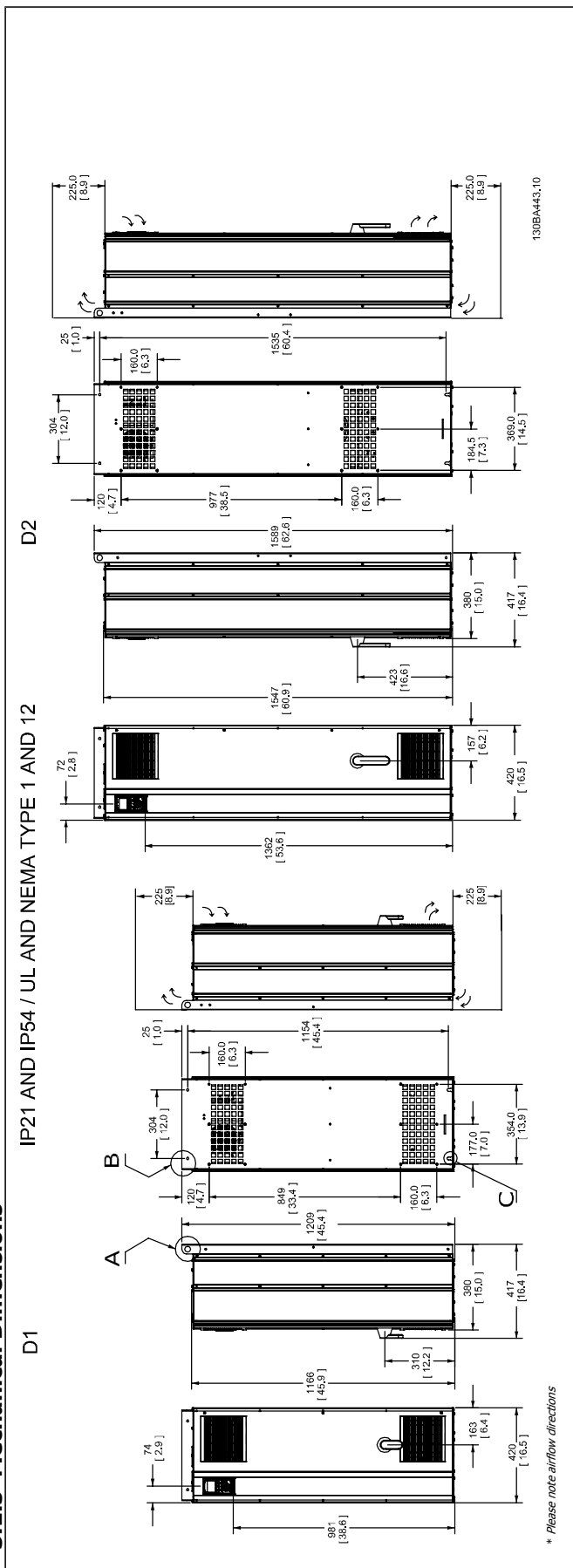

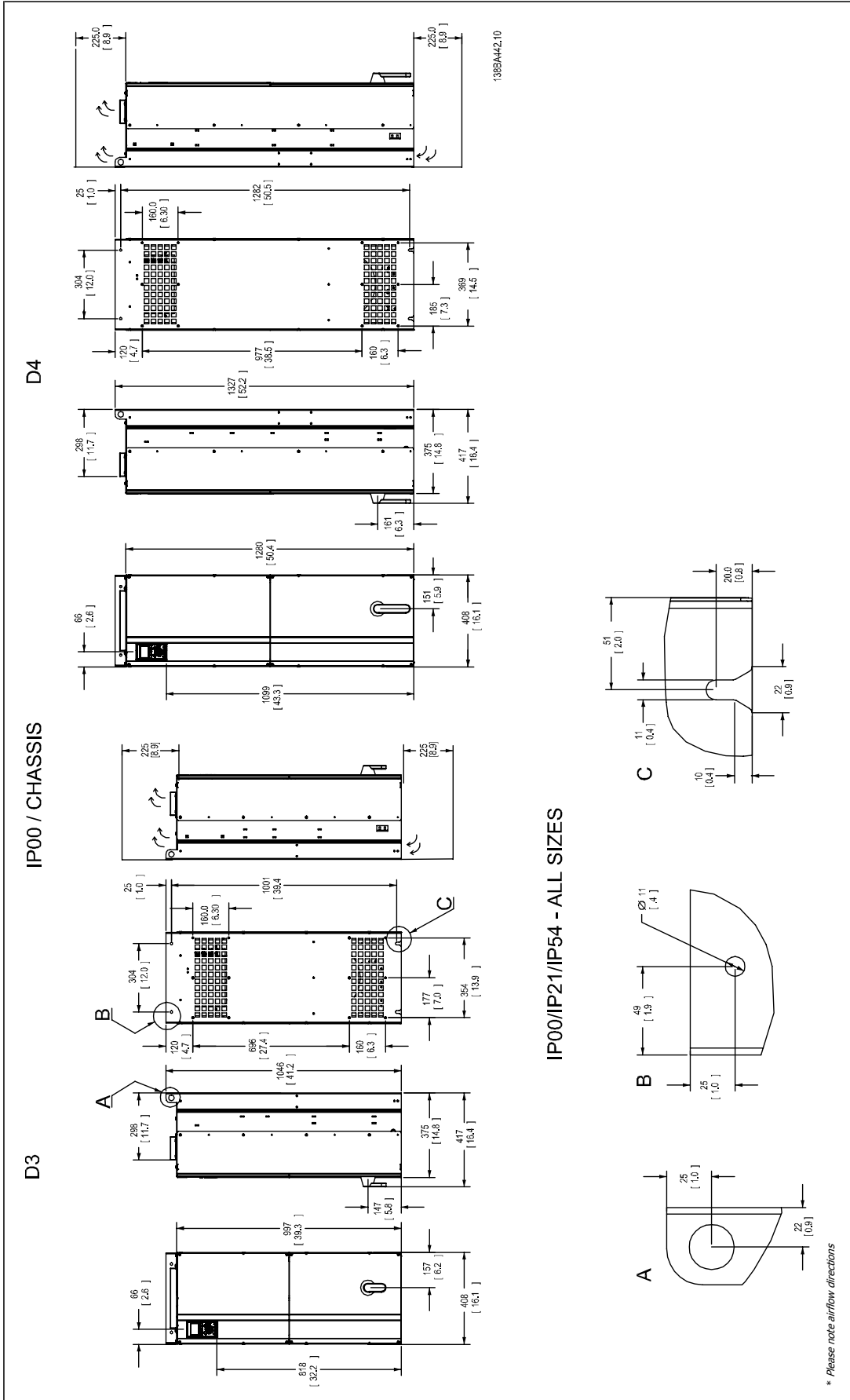

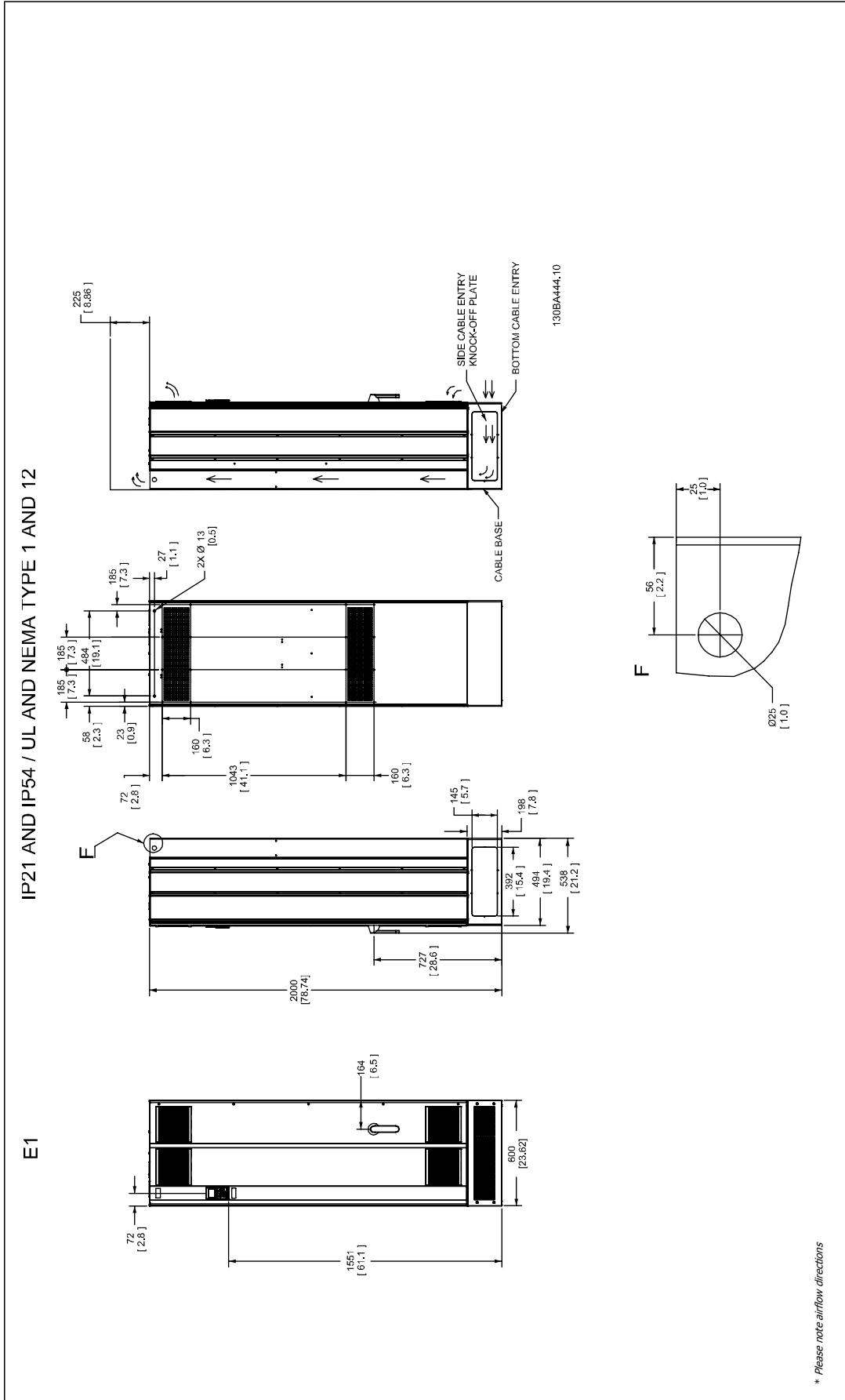

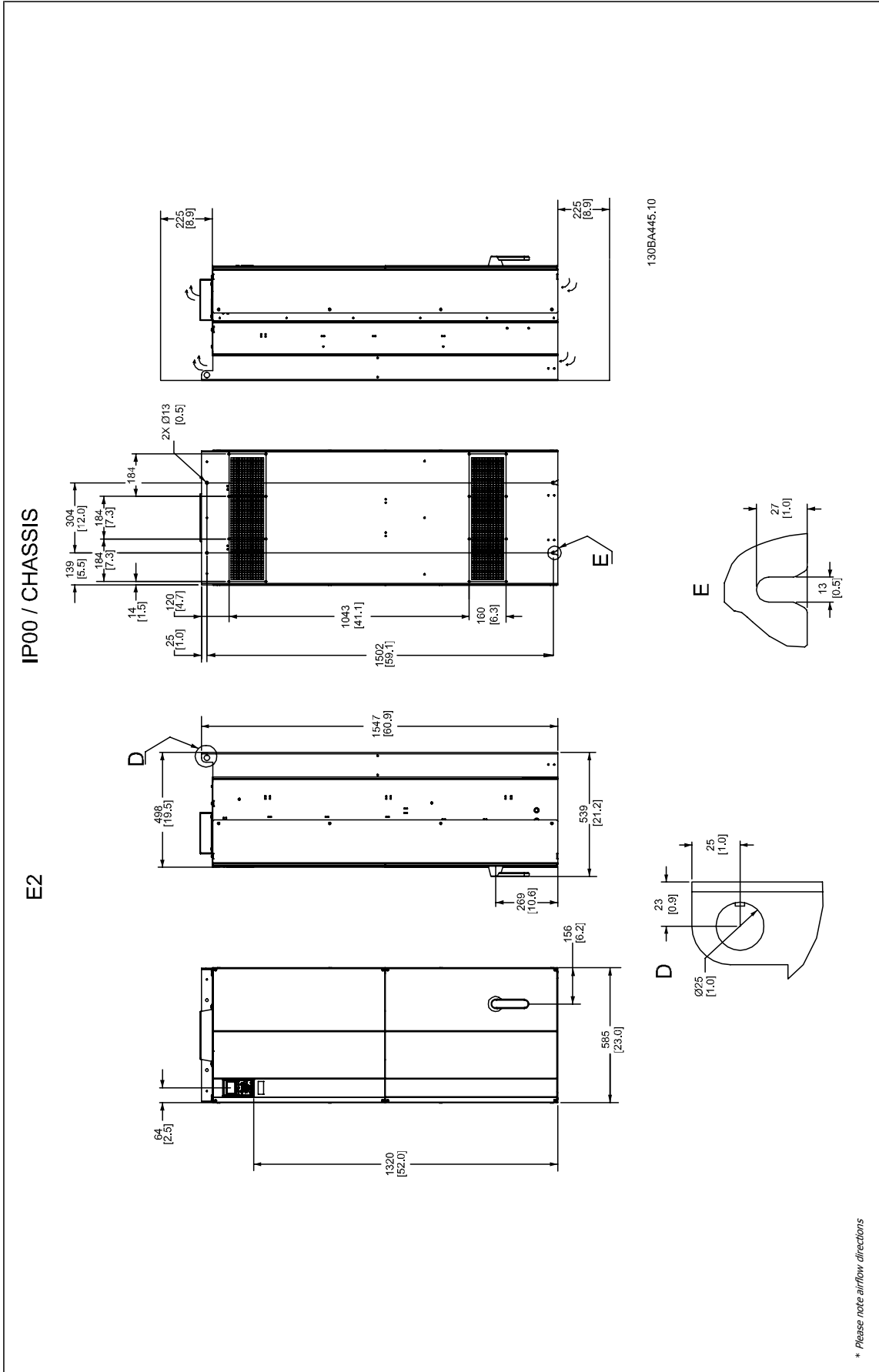

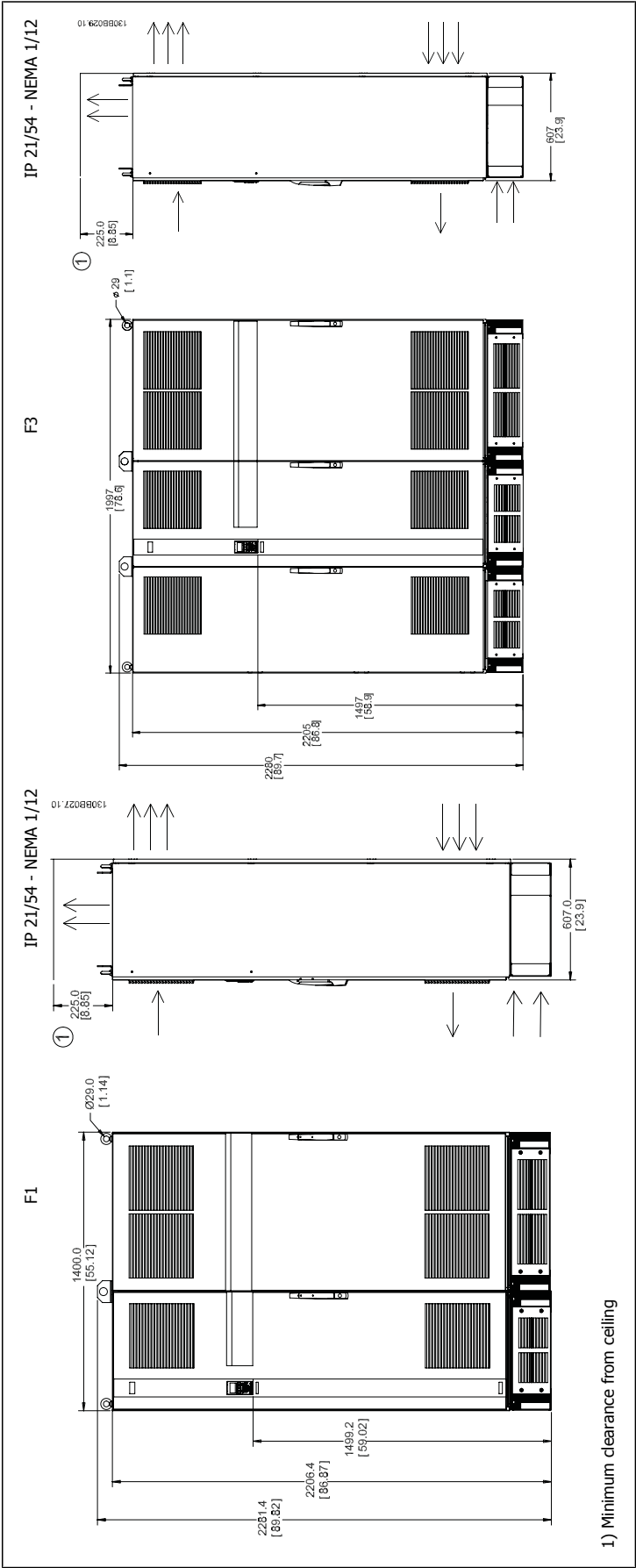

3

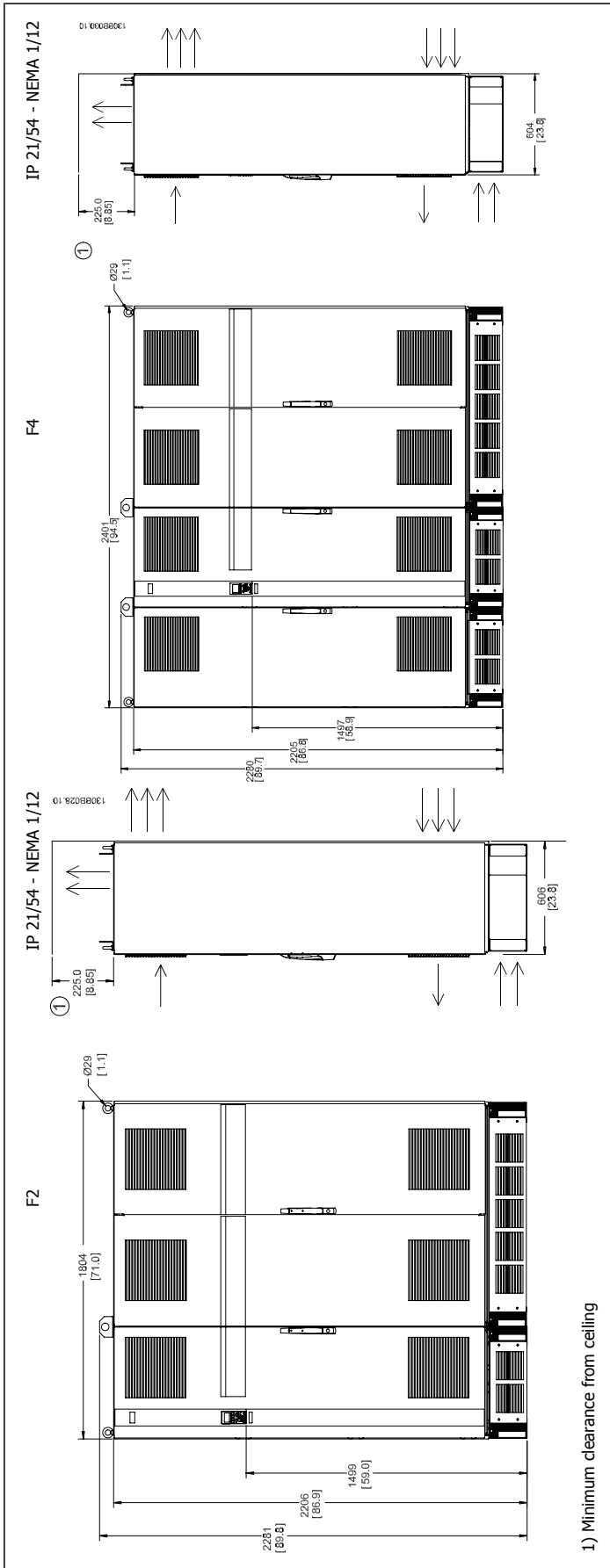



Mechanical dimensions, frame size D						
Frame size	D1		D2		D3	D4
	125–150 hp [90–110 kW] (380–500 V) 50–175 hp [37–132 kW] (525–690 V)		175–300 hp [132–200 kW] (380–500 V) 250–450 hp [160–315 kW] (525–690 V)		125–150 hp [90–110 kW] (380–500 V) 50–175 hp [37–132 kW] (525–690 V)	175–300 hp [132–200 kW] (380–500 V) 250–450 hp [160–315 kW] (525–690 V)
IP NEMA	21 Type 1	54 Type 12	21 Type 1	54 Type 12	00 Chassis	00 Chassis
Shipping dimensions	Height	25.59 in [650 mm]	25.59 in [650 mm]	25.59 in [650 mm]	25.59 in [650 mm]	25.59 in [650 mm]
	Width	68.11 in [1730 mm]	68.11 in [1730 mm]	68.11 in [1730 mm]	68.11 in [1730 mm]	48.03 in [1220 mm]
	Depth	22.48 in [570 mm]	22.48 in [570 mm]	22.48 in [570 mm]	22.48 in [570 mm]	22.48 in [570 mm]
Drive dimensions	Height	47.6 in [1209 mm]	47.6 in [1209 mm]	62.56 in [1589 mm]	62.56 in [1589 mm]	41.18 in [1046 mm]
	Width	16.54 in [420 mm]	16.54 in [420 mm]	16.54 in [420 mm]	16.54 in [420 mm]	16.06 in [408 mm]
	Depth	14.96 in [380 mm]	14.96 in [380 mm]	14.96 in [380 mm]	14.96 in [380 mm]	14.76 in [375 mm]
	Max weight	229.28 lb [104 kg]	229.28 lb [104 kg]	332.89 lb [151 kg]	332.89 lb [151 kg]	200.62 lb [91 kg]

Mechanical dimensions, frame sizes E and F						
Frame size	E1	E2	F1	F2	F3	F4
	350–550 hp [250–400 kW] (380–500 V) 500–750 hp [355–560 kW] (525–690 V)	350–550 hp [250–400 kW] (380–500 V) 500–750 hp [355–560 kW] (525–690 V)	600–850 hp [450–630 kW] (380–500 V) 850–1075 hp [630–800 kW] (525–690 V)	950–1075 hp [710–800 kW] (380–500 V) 1200–1350 hp [900–1200 kW] (525–690 V)	600–850 hp [450–630 kW] (380–500 V) 850–1075 hp [630–800 kW] (525–690 V)	950–1075 hp [710–800 kW] (380–500 V) 1200–1350 hp [900–1200 kW] (525–690 V)
IP NEMA	21, 54 Type 12	00 Chassis	21, 54 Type 12	21, 54 Type 12	21, 54 Type 12	21, 54 Type 12
Shipping dimensions	Height	33.07 in [840 mm]	32.73 in [831 mm]	91.50 in [2324 mm]	91.50 in [2324 mm]	91.50 in [2324 mm]
	Width	86.50 in [2197 mm]	67.13 in [1705 mm]	61.77 in [1569 mm]	77.24 in [1962 mm]	85 in [2159 mm]
	Depth	28.98 in [736 mm]	28.98 in [736 mm]	44.5 in [1130 mm]	44.5 in [1130 mm]	44.5 in [1130 mm]
Drive dimensions	Height	78.74 in [2000 mm]	60.91 in [1547 mm]	2204	2204	2204
	Width	23.62 in [600 mm]	23.03 in [585 mm]	1400	1800	2000
	Depth	19.45 in [494 mm]	19.61 in [498 mm]	606	606	606
	Max weight	690.05 lb [313 kg]	610.68 lb [277 kg]	1004	1246	1299

3

3.1.6 Rated Power

Frame size		D1	D2	D3	D4
					
Enclosure protection	IP	21/54	21/54	00	00
	NEMA	Type 1/ Type 12	Type 1/ Type 12	Chassis	Chassis
High overload rated power - 160% overload torque		125–150 hp [90–110 kW] at 400 V (380–500 V) 50–175 hp [37–132 kW] at 690 V (525–690 V)	175–300 hp [132–200 kW] at 400 V (380–500 V) 250–450 hp [160–315 kW] at 690 V (525–690 V)	125–150 hp [90–110 kW] at 400 V (380–500 V) 50–175 hp [37–132 kW] at 690 V (525–690 V)	175–300 hp [132–200 kW] at 400 V (380–500 V) 250–450 hp [160–315 kW] at 690 V (525–690 V)

Frame size		E1	E2	F1/F3	F2/F4
					
Enclosure protection	IP	21/54	00	21/54	21/54
	NEMA	Type 1/ Type 12	Chassis	Type 1/ Type 12	Type 1/ Type 12
High overload rated power - 160% overload torque		350–550 hp [250–400 kW] at 400 V (380–500 V) 500–750 hp [355–560 kW] at 690 V (525–690 V)	320–550 hp [240–400 kW] at 400 V (380–500 V) 500–750 hp [355–560 kW] at 690 V (525–690 V)	600–850 hp [450–630 kW] at 400 V (380–500 V) 850–1075 hp [630–800 kW] at 690 V (525–690 V)	950–1075 hp [710–800] kW at 400 V (380–500 V) 1200–1600 hp [900–1200 kW] at 690 V (525–690 V)



NOTE!

The F enclosures have four different sizes, F1, F2, F3 and F4. The F1 and F2 consist of an inverter cabinet on the right and rectifier cabinet on the left. The F3 and F4 have an additional options cabinet left of the rectifier cabinet. The F3 is an F1 with an additional options cabinet. The F4 is an F2 with an additional options cabinet.

3.2 Mechanical Installation

Preparation of the mechanical installation of the adjustable frequency drive must be done carefully to ensure proper results and to avoid additional work during installation. Start by taking a close look at the mechanical drawings at the end of this instruction manual to become familiar with the space demands.

3

3.2.1 Tools Needed

To perform the mechanical installation, the following tools are needed:

- Drill with 0.39 or 0.47 in [10 or 12 mm] drill.
- Tape measure
- Wrench with relevant metric sockets (0.28-0.67 in (7-17 mm))
- Extensions to wrench
- Sheet metal punch for conduits or cable connectors in IP 21/Nema 1 and IP 54 units
- Lifting bar to lift the unit (rod or tube max. Ø1 in [25 mm], able to lift minimum 880 lbs [400 kg]).
- Crane or other lifting aid to place the adjustable frequency drive in position
- A Torx T50 tool is needed to install the E1 in IP21 and IP54 enclosure types.

3.2.2 General Considerations

Space

Ensure proper space above and below the adjustable frequency drive to allow airflow and cable access. In addition, space in front of the unit must be considered to allow the panel door to be opened.

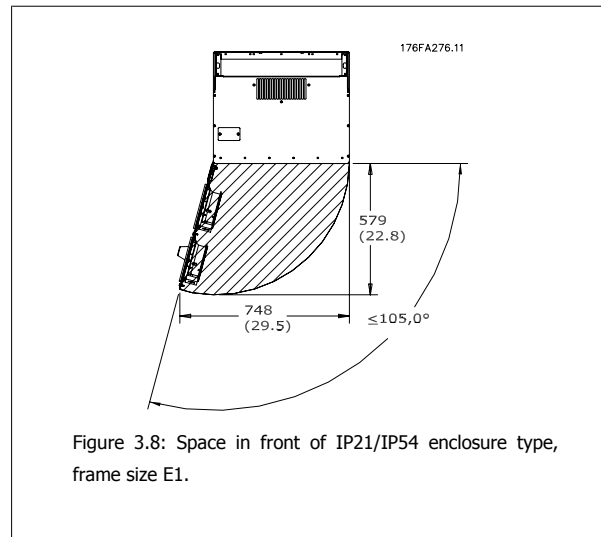
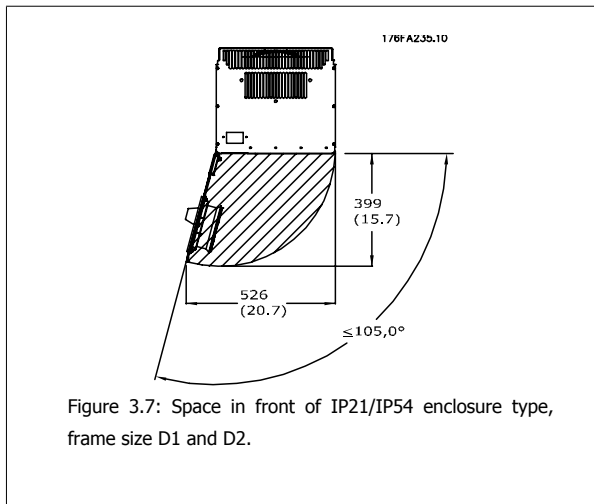

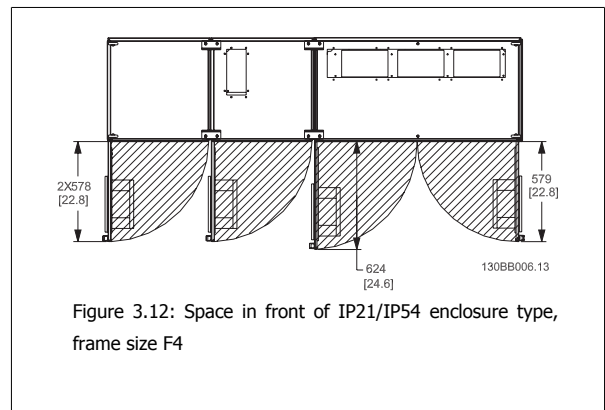
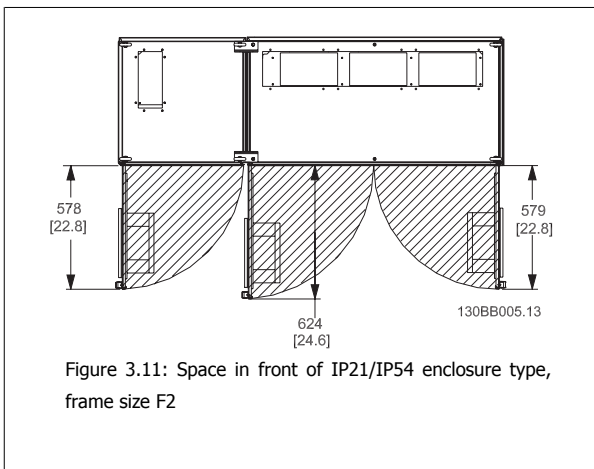
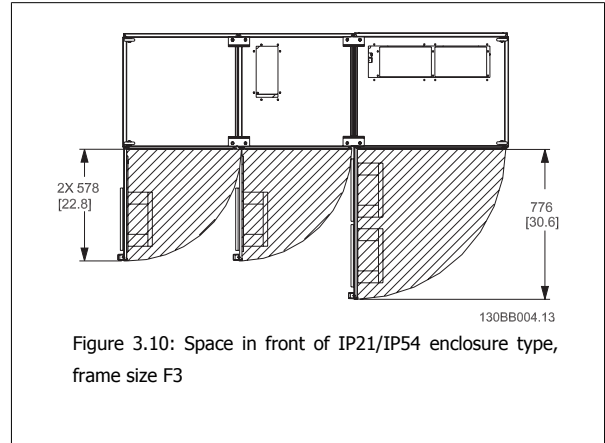
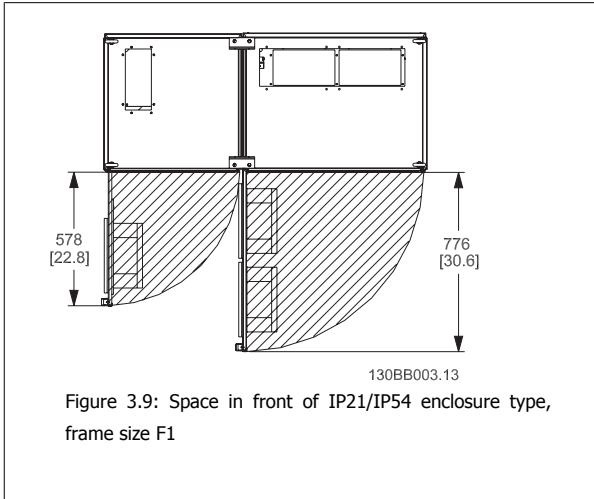

Wire access

Ensure that proper cable access is present including the necessary bending allowance. As the IP00 enclosure is open to the bottom cables must be fixed to the back panel of the enclosure where the adjustable frequency drive is mounted, i.e., by using cable clamps.



NOTE!
All cable lugs/shoes must mount within the width of the terminal bus bar.

3.2.3 Terminal Locations - Frame size D

Take the following terminal positions into consideration when you design for cable access.

3

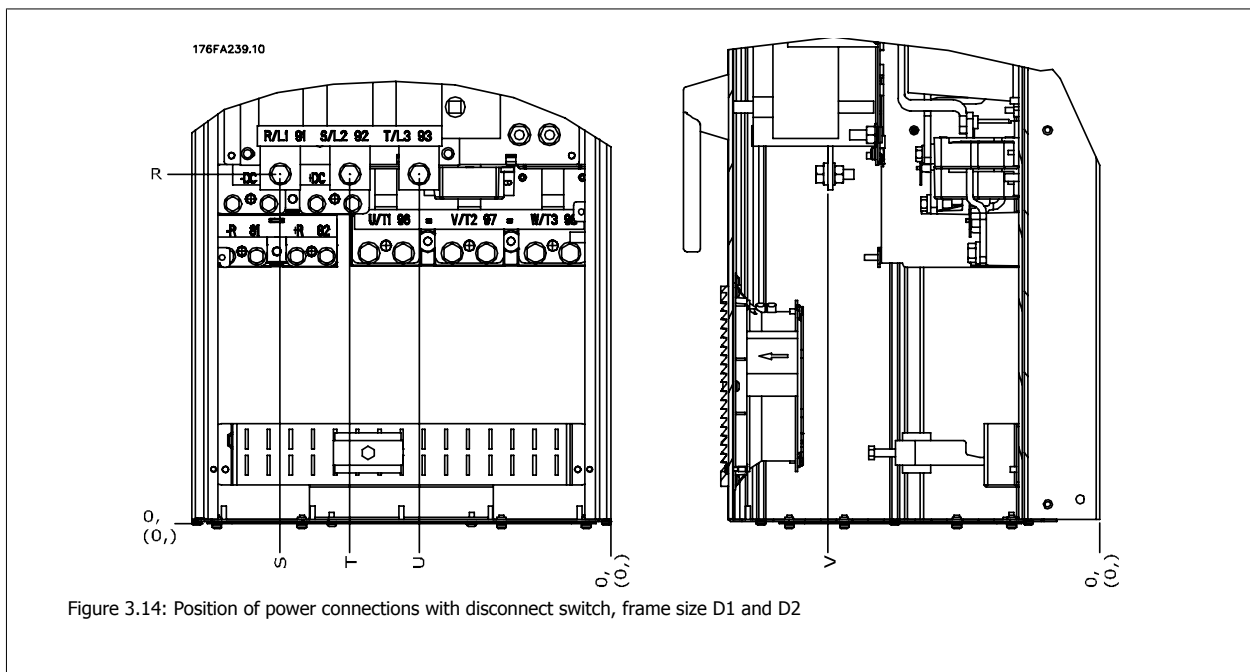
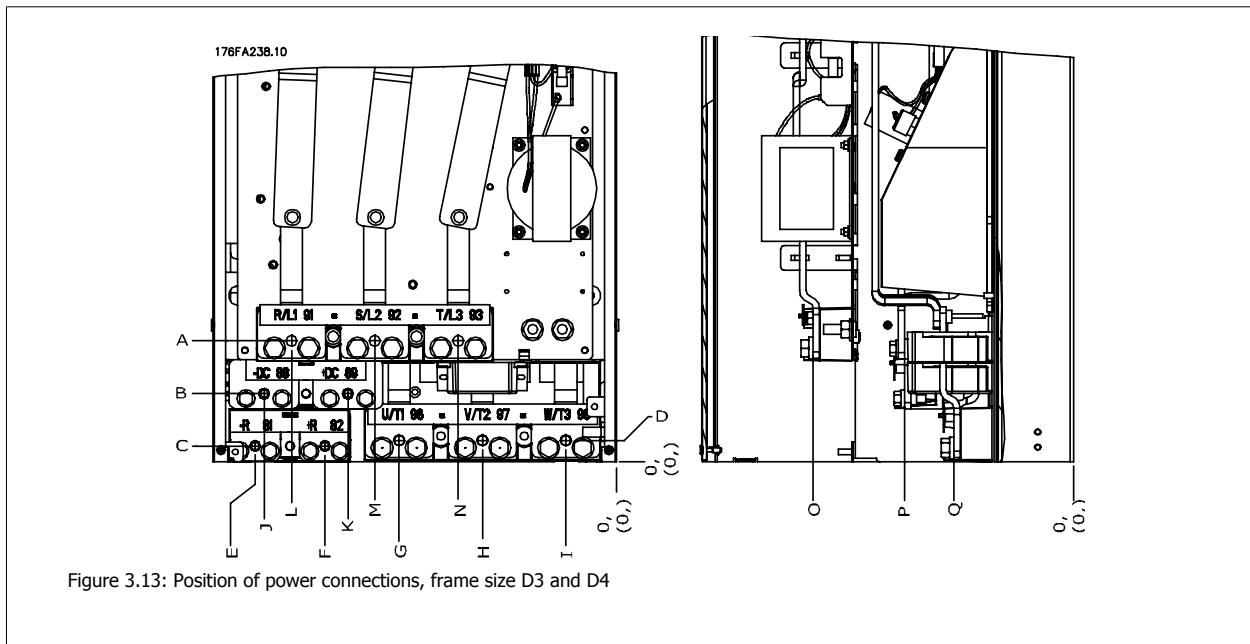

Be aware that the power cables are heavy and hard to bend. Give thought to the optimum position of the adjustable frequency drive for ensuring easy installation of the cables.

NOTE!
All D frames are available with standard input terminals or disconnect switch. All terminal dimensions can be found in the following table.

3

	IP 21 (NEMA 1) / IP 54 (NEMA 12)		IP 00 / Chassis	
	Frame size D1	Frame size D2	Frame size D3	Frame size D4
A	277 (10.9)	379 (14.9)	119 (4.7)	122 (4.8)
B	227 (8.9)	326 (12.8)	68 (2.7)	68 (2.7)
C	173 (6.8)	273 (10.8)	15 (0.6)	16 (0.6)
D	179 (7.0)	279 (11.0)	20.7 (0.8)	22 (0.8)
E	370 (14.6)	370 (14.6)	363 (14.3)	363 (14.3)
F	300 (11.8)	300 (11.8)	293 (11.5)	293 (11.5)
G	222 (8.7)	226 (8.9)	215 (8.4)	218 (8.6)
H	139 (5.4)	142 (5.6)	131 (5.2)	135 (5.3)
I	55 (2.2)	59 (2.3)	48 (1.9)	51 (2.0)
J	354 (13.9)	361 (14.2)	347 (13.6)	354 (13.9)
K	284 (11.2)	277 (10.9)	277 (10.9)	270 (10.6)
L	334 (13.1)	334 (13.1)	326 (12.8)	326 (12.8)
M	250 (9.8)	250 (9.8)	243 (9.6)	243 (9.6)
N	167 (6.6)	167 (6.6)	159 (6.3)	159 (6.3)
O	261 (10.3)	260 (10.3)	261 (10.3)	261 (10.3)
P	170 (6.7)	169 (6.7)	170 (6.7)	170 (6.7)
Q	120 (4.7)	120 (4.7)	120 (4.7)	120 (4.7)
R	256 (10.1)	350 (13.8)	98 (3.8)	93 (3.7)
S	308 (12.1)	332 (13.0)	301 (11.8)	324 (12.8)
T	252 (9.9)	262 (10.3)	245 (9.6)	255 (10.0)
U	196 (7.7)	192 (7.6)	189 (7.4)	185 (7.3)
V	260 (10.2)	273 (10.7)	260 (10.2)	273 (10.7)

Table 3.1: Cable positions as shown in the drawings above. Dimensions in mm (inches).

3.2.4 Terminal Locations - Frame size E

Terminal Locations - E1

Give thought to the following terminal positions when designing the cable access.

3

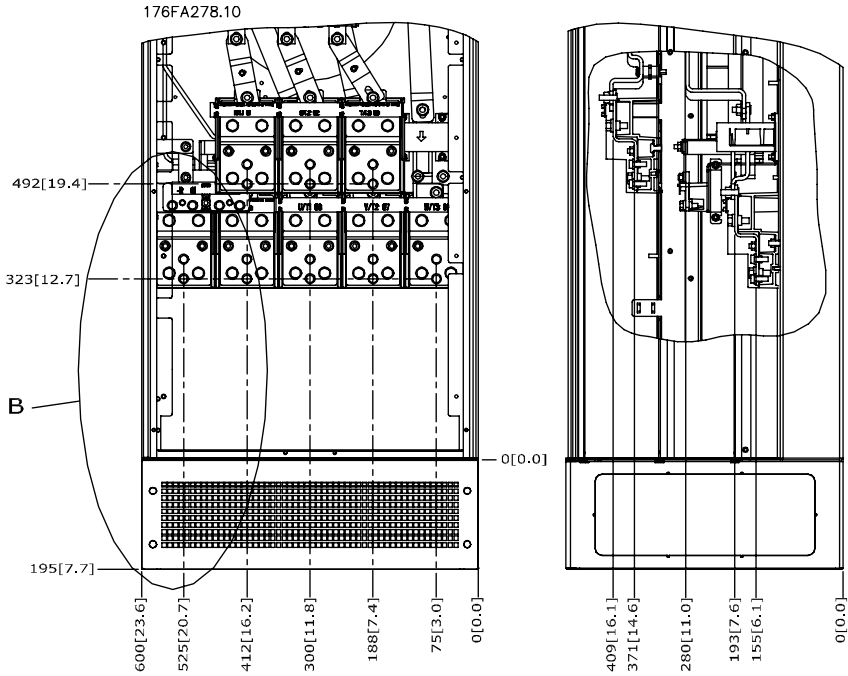

Figure 3.15: IP21 (NEMA Type 1) and IP54 (NEMA Type 12) enclosure power connection positions

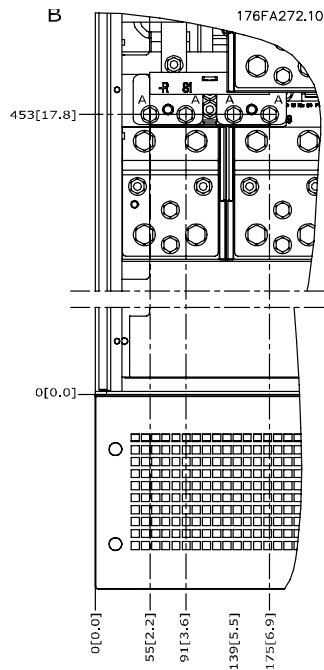

Figure 3.16: IP21 (NEMA type 1) and IP54 (NEMA type 12) enclosure power connection positions (detail B)

3

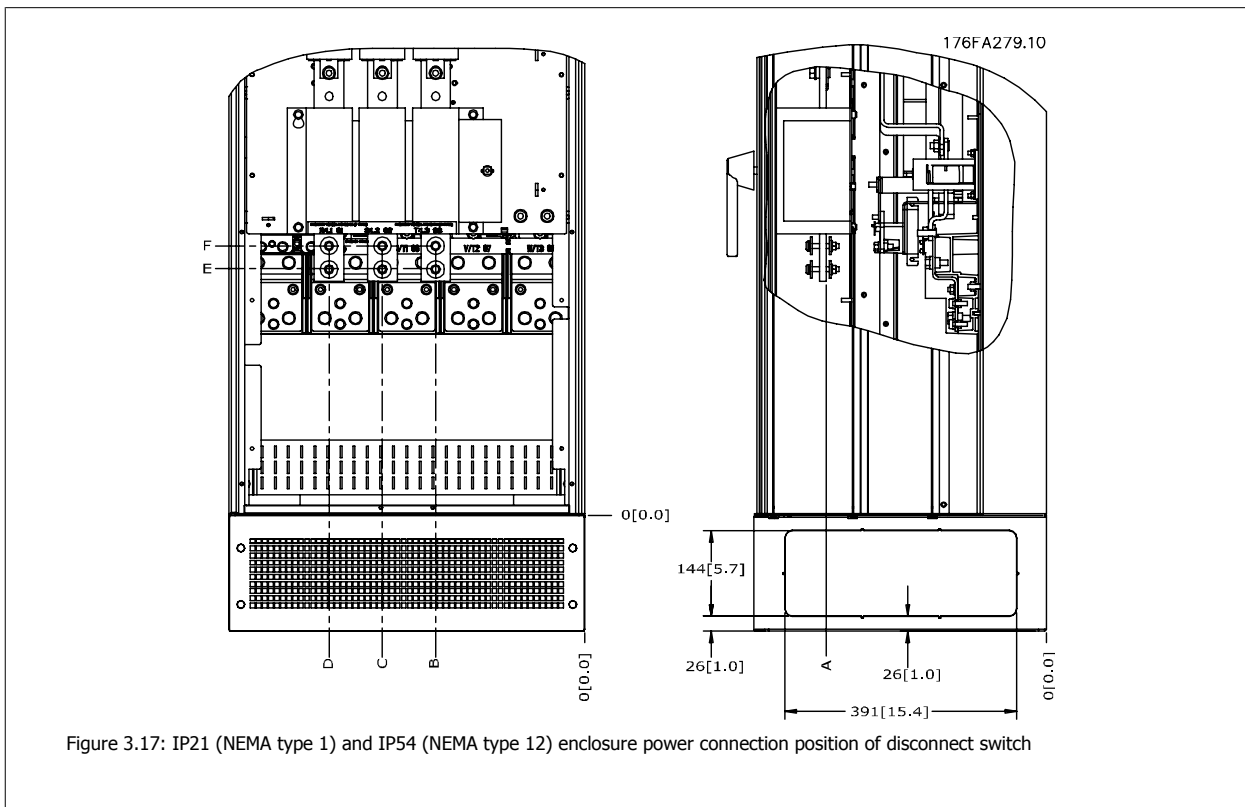

Figure 3.17: IP21 (NEMA type 1) and IP54 (NEMA type 12) enclosure power connection position of disconnect switch

Frame size	Unit type	Dimension for disconnect terminal					
E1	IP54/IP21 UL AND NEMA1/NEMA12						
	350/450 hp [250/315 kW] (400 V) AND 500/600–675/850 hp [355/450–500/630 kW] (690 V)	381 (15.0)	253 (9.9)	253 (9.9)	431 (17.0)	562 (22.1)	N/A
	450/500–550/600 hp [315/355-400/450 kW] (400 V)	371 (14.6)	371 (14.6)	341 (13.4)	431 (17.0)	431 (17.0)	455 (17.9)

Terminal locations - Frame size E2

Give thought to the following terminal positions when designing the cable access.

3

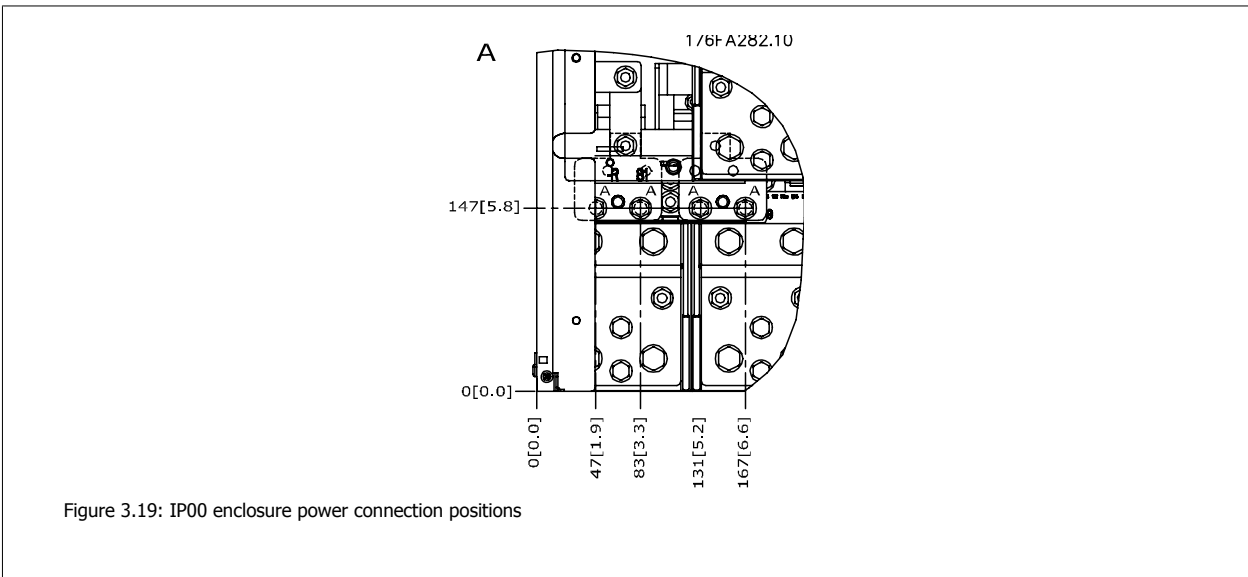
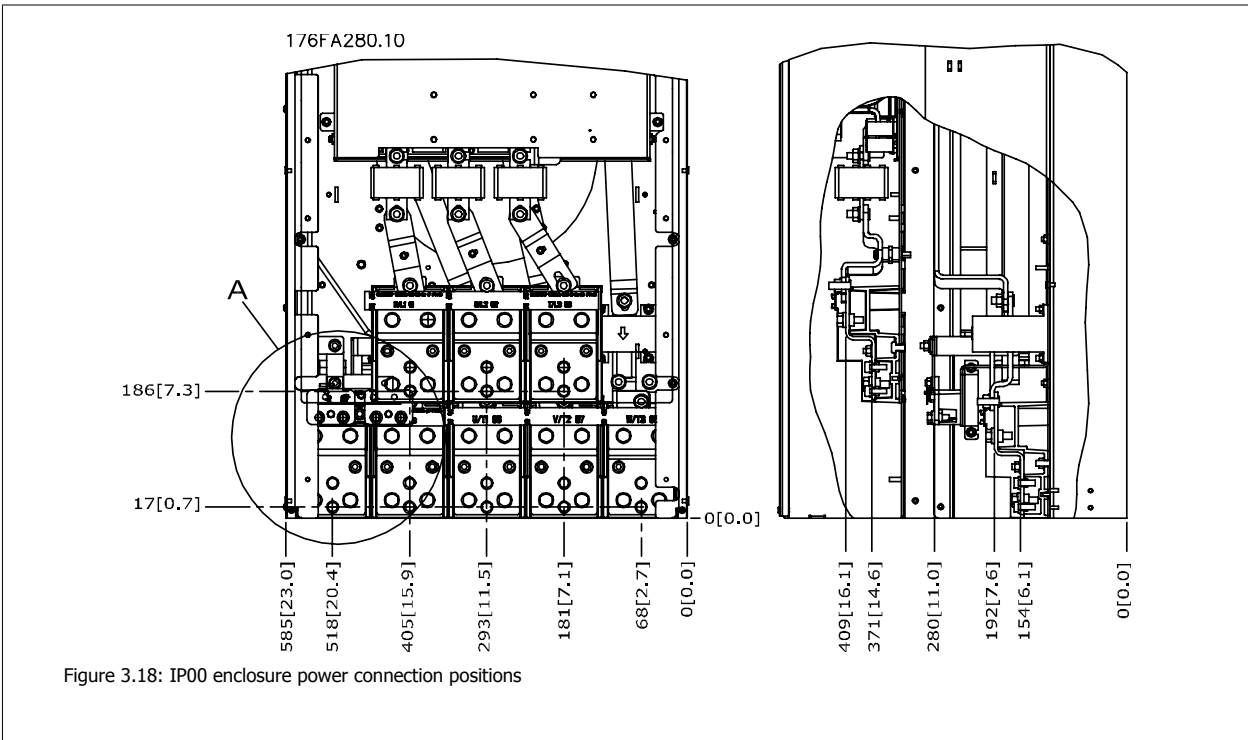

3

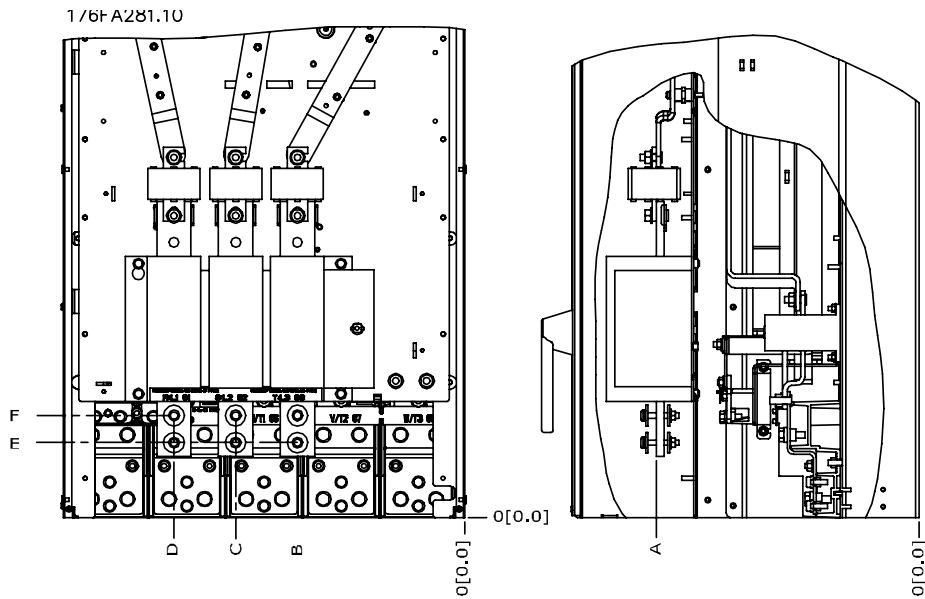

Figure 3.20: IP00 enclosure power connections positions of disconnect switch

Note that the power cables are heavy and difficult to bend. Give thought to the optimum position of the adjustable frequency drive for ensuring easy installation of the cables.

Each terminal allows for the use of up to 4 cables with cable lugs or the use of standard box lug. Ground is connected to relevant termination point in the drive.

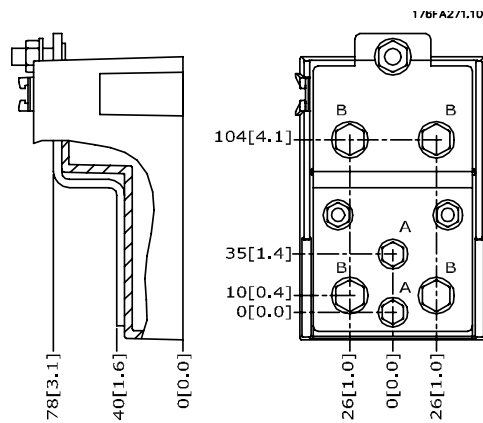

Figure 3.21: Terminal in details



NOTE!

Power connections can be made to positions A or B

Frame size	Unit type	Dimension for disconnect terminal					
		A	B	C	D	E	F
E2	IPOO/CHASSIS						
	350/450 hp [250/315 kW] (400 V) AND 500/600–675/850 hp [355/450–500/630 kW] (690 V)	381 (15.0)	245 (9.6)	334 (13.1)	423 (16.7)	256 (10.1)	N/A
	450/500–550/600 hp [315/355–400/450 kW] (400 V)	383 (15.1)	244 (9.6)	334 (13.1)	424 (16.7)	109 (4.3)	149 (5.8)

3.2.5 Terminal Locations - Frame size F



NOTE!

The F frames have four different sizes, F1, F2, F3 and F4. The F1 and F2 consist of an inverter cabinet on the right and rectifier cabinet on the left. The F3 and F4 have an additional options cabinet left of the rectifier cabinet. The F3 is an F1 with an additional options cabinet. The F4 is an F2 with an additional options cabinet.

Terminal locations - Frame size F1 and F3

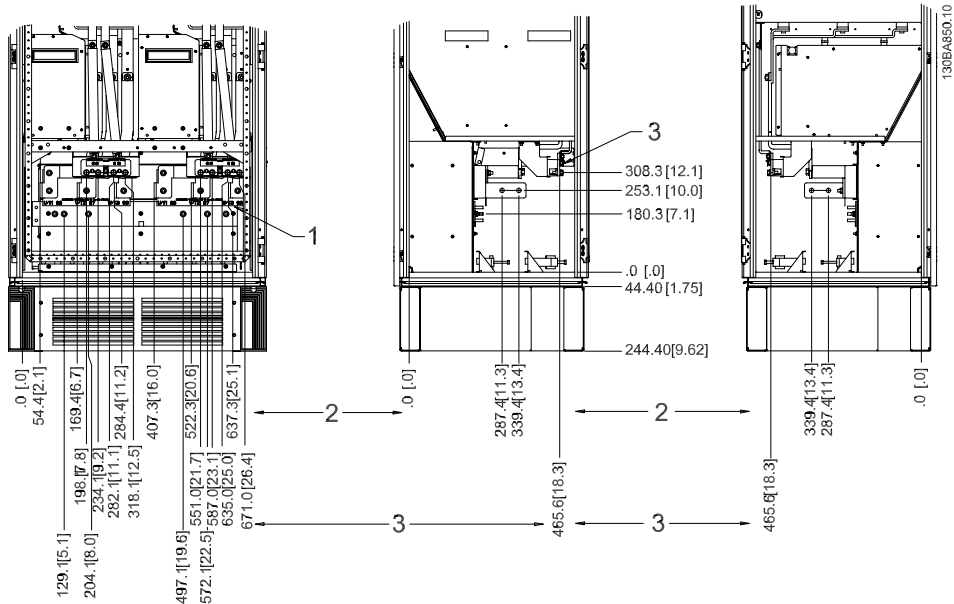
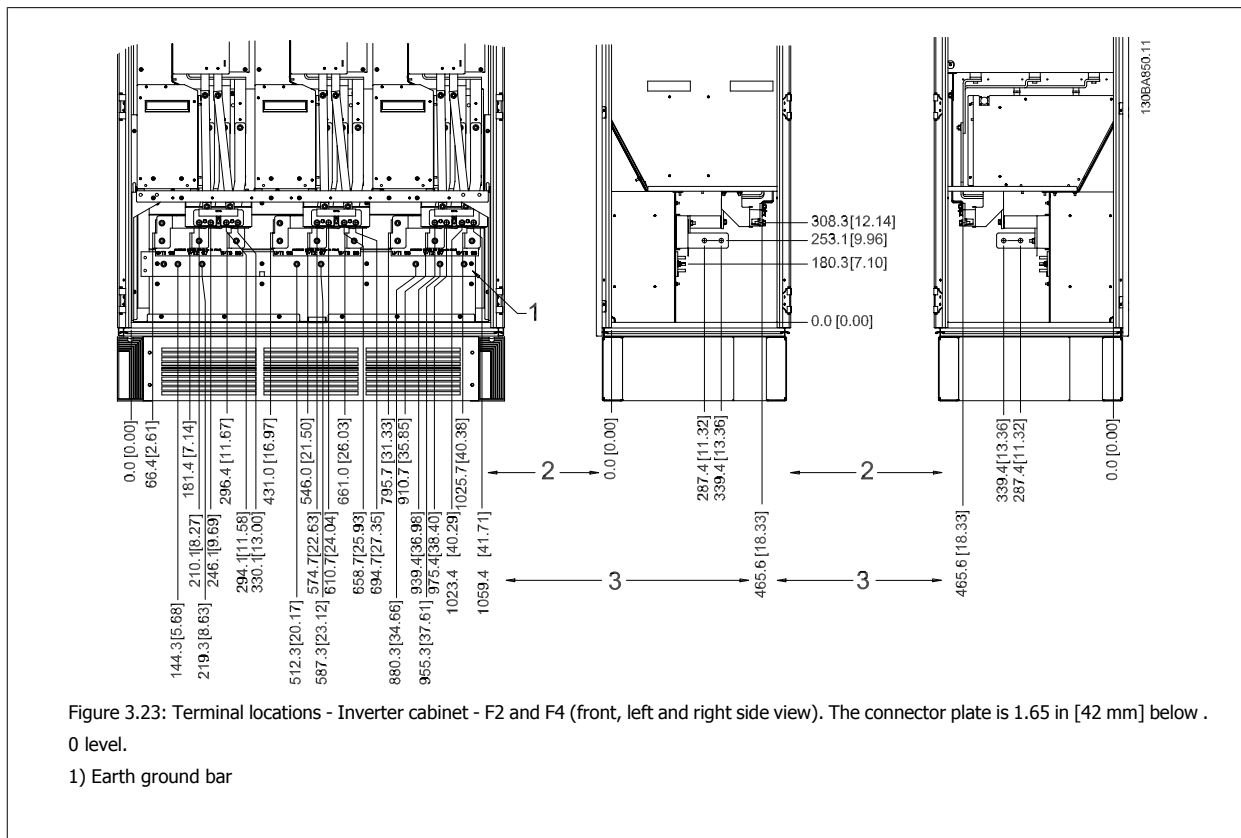

Figure 3.22: Terminal locations - Inverter Cabinet - F1 and F3 (front, left and right side view). The connector plate is 1.65 in [42 mm] below 0 level.

- 1) Earth ground bar
- 2) Motor terminals
- 3) Brake terminals

Terminal locations - Frame size F2 and F4



3

Terminal locations - Rectifier (F1, F2, F3 and F4)

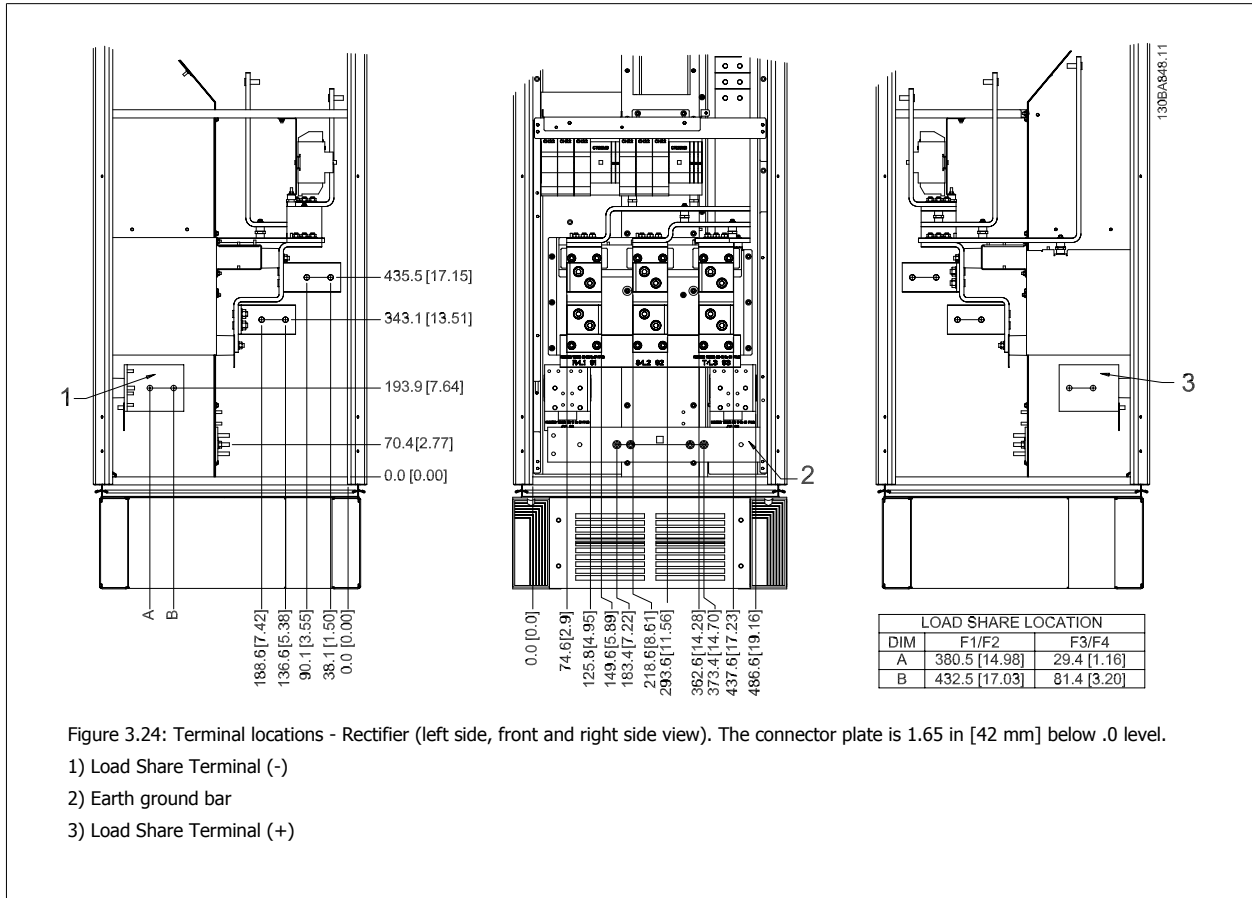

Terminal locations - Options cabinet (F3 and F4)

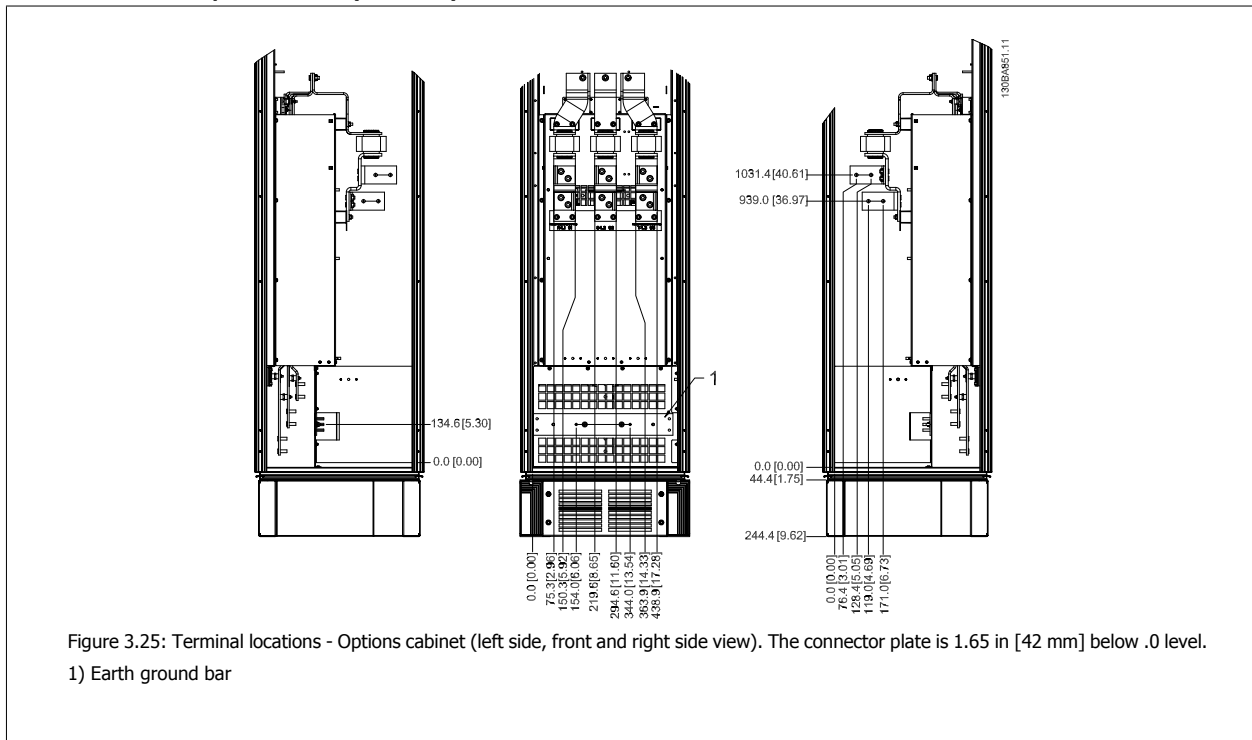

Terminal locations - Options Cabinet with circuit breaker/ molded case switch (F3 and F4)

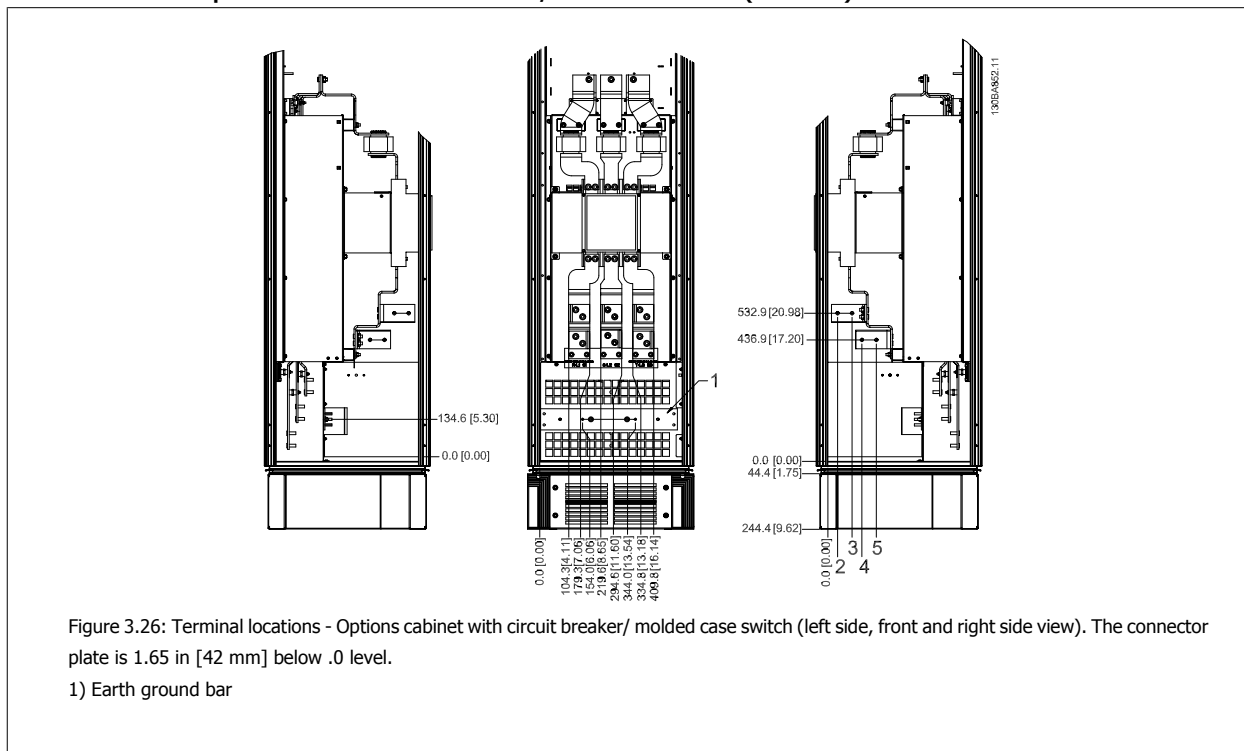

Power size	2	3	4	5
450 kW (480 V), 630–710 kW (690 V)	34.9	86.9	122.2	174.2
500–800 kW (480 V), 800–1000 kW (690 V)	46.3	98.3	119.0	171.0

Table 3.2: Dimension for terminal

3.2.6 Cooling and Airflow

Cooling

Cooling can be obtained in different ways, by using the cooling ducts in the bottom and the top of the unit, by taking air in and out the back of the unit or by combining the cooling possibilities.

Duct cooling

A dedicated option has been developed to optimize installation of IP00/chassis adjustable frequency drives in Rittal TS8 enclosures utilizing the fan of the adjustable frequency drive for forced air cooling of the backchannel. The air out the top of the enclosure could but ducted outside a facility so the heat losses from the backchannel are not dissipated within the control room reducing air-conditioning requirements of the facility.

Please see *Installation of Duct Cooling Kit in Rittal enclosures*, for further information.

Back cooling

The backchannel air can also be ventilated in and out the back of a Rittal TS8 enclosure. This offers a solution where the backchannel could take air from outside the facility and return the heat losses outside the facility thus reducing air-conditioning requirements.



NOTE!

A door fan is required on the enclosure to remove the heat losses not contained in the backchannel of the drive and any additional losses generated from other components installed inside the enclosure. The total required airflow must be calculated so that the appropriate fans can be selected. Some enclosure manufacturers offer software for performing the calculations (e.g., Rittal Therm software). If the VLT is the only heat generating component in the enclosure, the minimum airflow required at an ambient temperature of 113°F [45°C] for the D3 and D4 drives is 391 m³/h (230 cfm). The minimum airflow required at an ambient temperature of 113°F [45°C] for the E2 drive is 782 m³/h (460 cfm).

Airflow

The necessary airflow over the heatsink must be ensured. The flow rate is shown below.

Enclosure protection	Frame size	Door fan(s) / Top fan airflow	Heatsink fan(s)
IP21 / NEMA 1	D1 and D2	170 m ³ /h (100 cfm)	765 m ³ /h (450 cfm)
IP54 / NEMA 12	E1 P250T5, P355T7, P400T7	340 m ³ /h (200 cfm)	1105 m ³ /h (650 cfm)
	E1 P315-P400T5, P500-P560T7	340 m ³ /h (200 cfm)	1445 m ³ /h (850 cfm)
IP21 / NEMA 1	F1, F2, F3 and F4	700 m ³ /h (412 cfm)*	985 m ³ /h (580 cfm)*
IP54 / NEMA 12	F1, F2, F3 and F4	525 m ³ /h (309 cfm)*	985 m ³ /h (580 cfm)*
IP00 / Chassis	D3 and D4	255 m ³ /h (150 cfm)	765 m ³ /h (450 cfm)
	E2 P250T5, P355T7, P400T7	255 m ³ /h (150 cfm)	1105 m ³ /h (650 cfm)
	E2 P315-P400T5, P500-P560T7	255 m ³ /h (150 cfm)	1445 m ³ /h (850 cfm)

* Airflow per fan. Frame size F contain multiple fans.

Table 3.3: Heatsink Airflow



NOTE!

The fan runs for the following reasons:

1. AMA
2. DC Hold
3. Pre-Mag
4. DC Brake
5. 60% of nominal current is exceeded
6. Specific heatsink temperature exceeded (power-size dependent).

Once the fan is started, it will run for a minimum of 10 minutes.

External ducts

If additional duct work is added externally to the Rittal cabinet, the pressure drop in the ducting must be calculated. Use the charts below to derate the adjustable frequency drive according to the pressure drop.

3

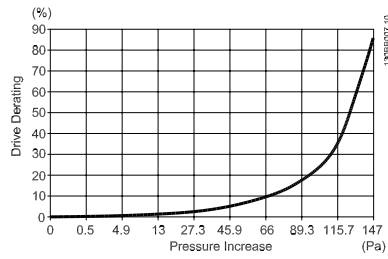

Figure 3.27: D frame Derating vs. Pressure Change

Drive airflow: 450 cfm (765 m³/h)

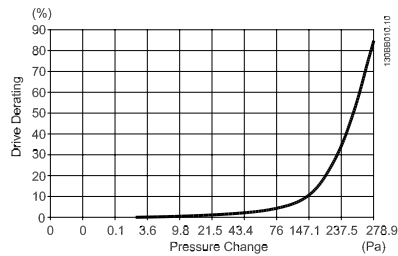

Figure 3.28: E frame Derating vs. Pressure Change (Small Fan), P250T5 and P355T7-P400T7

Drive airflow: 650 cfm (1105 m³/h)

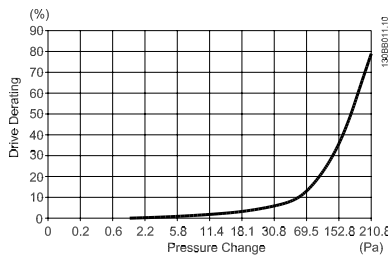

Figure 3.29: E frame Derating vs. Pressure Change (Large Fan), P315T5-P400T5 and P500T7-P560T7

Drive airflow: 850 cfm (1445 m³/h)

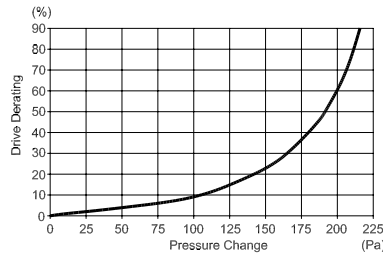

Figure 3.30: F1, F2, F3, F4 frame Derating vs. Pressure Change
Drive airflow: 580 cfm (985 m³/h)

3.2.7 Installation on the wall - IP21 (NEMA 1) and IP54 (NEMA 12) Units

This only applies to frame sizes D1 and D2 . Thought must be given to where the unit should be installed.

Take the relevant points into consideration before you select the final installation site:

- Clearance space for cooling
- Clearance for opening the door
- Cable entry clearance from the bottom

Mark the mounting holes carefully using the mounting template on the wall, and drill the holes as indicated. Ensure proper distance to the floor and the ceiling for cooling. A minimum of 8.9 in [225 mm] below the adjustable frequency drive is needed. Mount the bolts at the bottom and lift the adjustable frequency drive up on the bolts. Tilt the adjustable frequency drive against the wall and mount the upper bolts. Tighten all four bolts to secure the adjustable frequency drive against the wall.

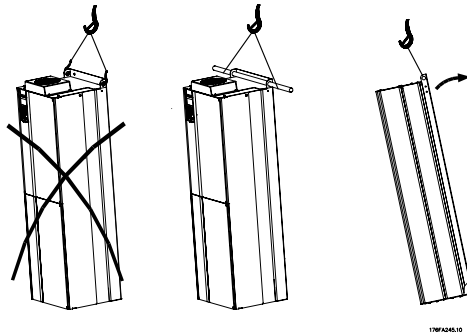

Figure 3.31: Lifting method for mounting drive on wall

3.2.8 Connector/Conduit Entry - IP21 (NEMA 1) and IP54 (NEMA12)

Cables are connected through the connector plate from the bottom. Remove the plate and plan where to place the entry for the connectors or conduits. Prepare holes in the marked area on the drawing.

NOTE!
 The connector plate must be fitted to the adjustable frequency drive to ensure the specified protection degree, as well as ensuring proper cooling of the unit. If the connector plate is not mounted, the adjustable frequency drive may trip on Alarm 69, Pwr. Card Temp



1308B073.10

Figure 3.32: Example of proper installation of the connector plate.

Frame size D1 + D2

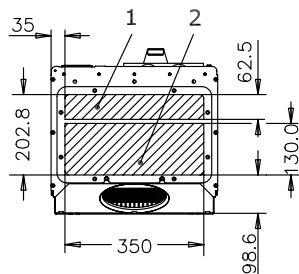

176FA289.11

Frame size E1

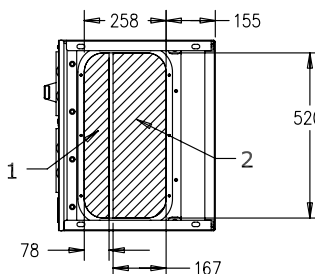

176FA290.11

Cable entries viewed from the bottom of the adjustable frequency drive - 1) Line power side 2) Motor side

Frame size F1

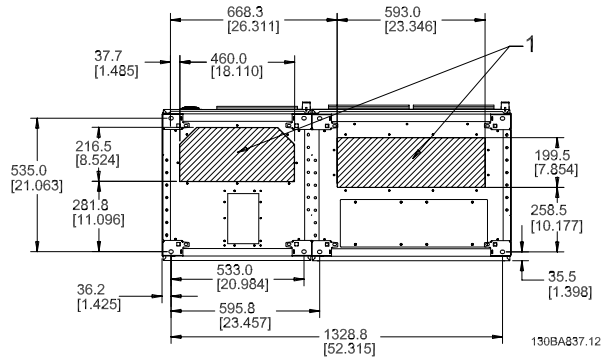

Frame size F2

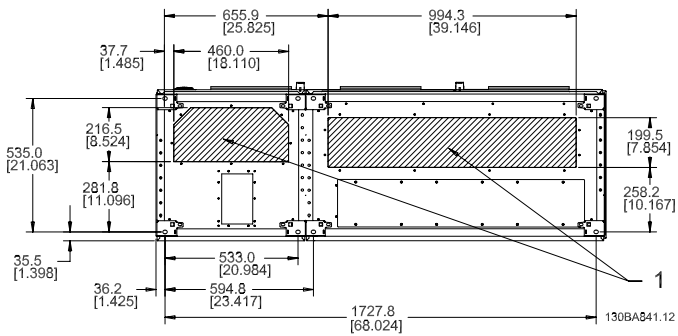

Frame size F3

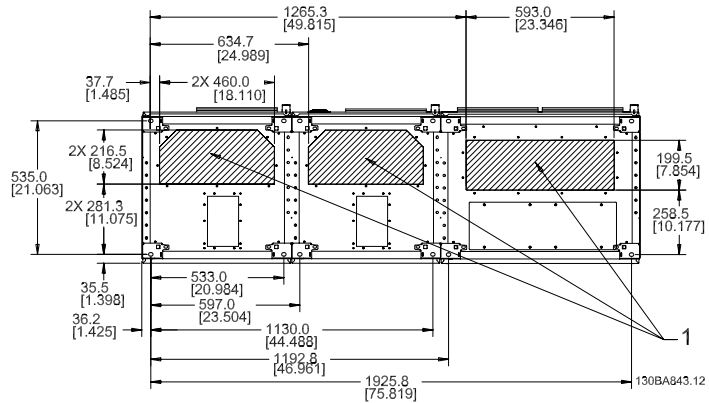

Frame size F4

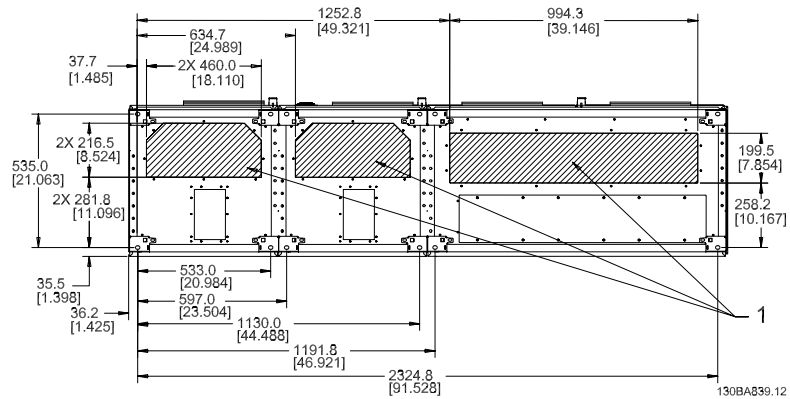

F1-F4: Cable entries viewed from the bottom of the adjustable frequency drive - 1) Place conduits in marked areas

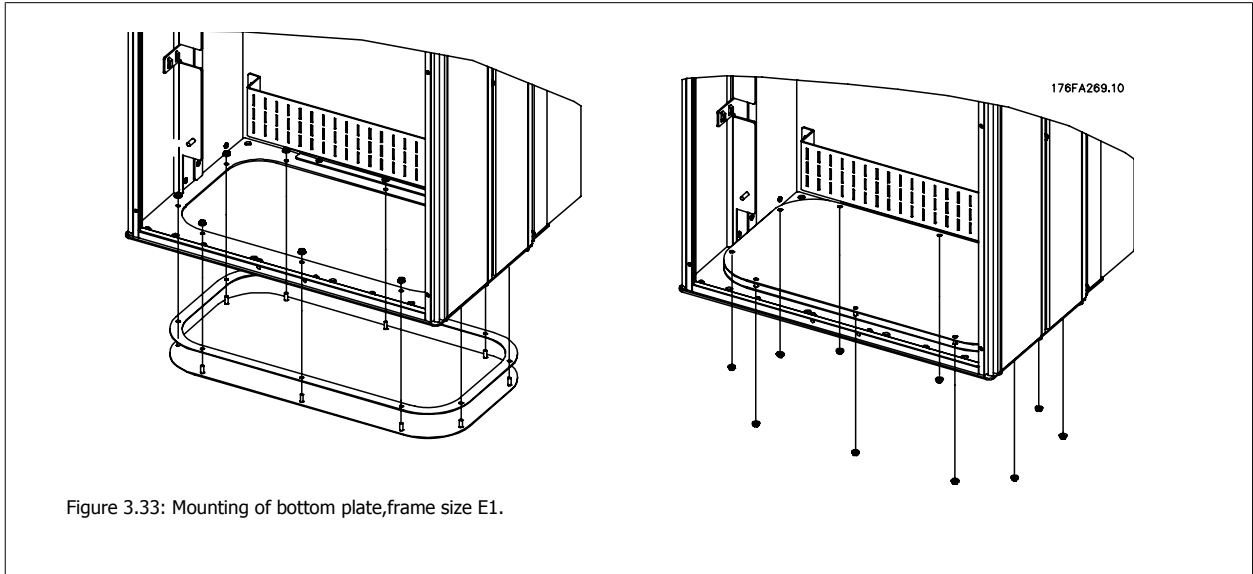

Figure 3.33: Mounting of bottom plate, frame size E1.

The bottom plate of the E1 can be mounted from either inside or outside of the enclosure, allowing flexibility in the installation process, i.e., if mounted from the bottom the connectors and cables can be mounted before the adjustable frequency drive is placed on the pedestal.

3.2.9 IP21 Drip Shield Installation (Frame size D1 and D2)

To comply with the IP21 rating, a separate drip shield is to be installed as explained below:

- Remove the two front screws.
- Insert the drip shield and replace the screws.
- Torque the screws to 5.6 Nm (50 in-lbs).

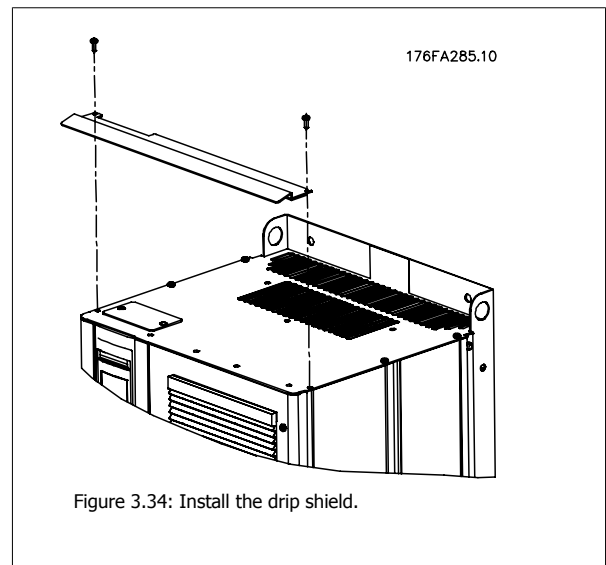

Figure 3.34: Install the drip shield.

3.3 Field Installation of Options

3.3.1 Installation of Duct Cooling Kit in Rittal Enclosures

This section deals with the installation of IP00 / chassis enclosed adjustable frequency drives with duct work cooling kits in Rittal enclosures. In addition to the enclosure an 8 in [200 mm] base/plinth is required.

3

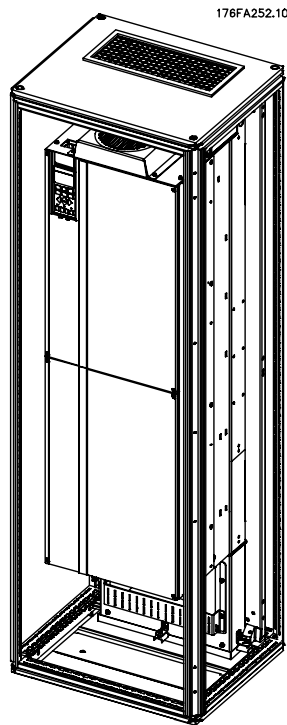

Figure 3.35: Installation of IP00 in Rittal TS8 enclosure.

The minimum enclosure dimension is:

- D3 and D4 frame: Depth 19.7 in [500 mm] and width 23.6 in [600 mm].
- E2 frame: Depth 23.6 in [600 mm] and width 31.5 in [800 mm].

The maximum depth and width are as required for the installation. When using multiple adjustable frequency drives in one enclosure it is recommended that each drive is mounted on its own back panel and supported along the mid-section of the panel. These duct work kits do not support the "in frame" mounting of the panel (see Rittal TS8 catalog for details). The duct work cooling kits listed in the table below are suitable for use only with IP 00 / Chassis adjustable frequency drives in Rittal TS8 IP 20 and UL and NEMA 1 and IP 54 and UL and NEMA 12 enclosures.



For the E2 frames, it is important to mount the plate at the absolute rear of the Rittal enclosure due to the weight of the adjustable frequency drive.



NOTE!
 A door fan is required on the enclosure to remove the heat losses not contained in the backchannel of the drive and any additional losses generated from other components installed inside the enclosure. The total required air flow must be calculated so that the appropriate fans can be selected. Some enclosure manufacturers offer software for performing the calculations (i.e., Rittal Therm software). If the VLT is the only heat generating component in the enclosure, the minimum airflow required at an ambient temperature of 113°F [45°C] for the D3 and D4 drives is 391 m³/h (230 cfm). The minimum airflow required at an ambient temperature of 113°F [45°C] for the E2 drive is 782 m³/h (460 cfm).

Ordering Information

Rittal TS-8 Enclosure	Frame D3 Kit Part No.	Frame D4Kit Part No.	Frame E2 Part No.
70.9 in [1800 mm]	176F1824	176F1823	Not possible
78.7 in [2000 mm]	176F1826	176F1825	176F1850
86.6 in [2200 mm]			176F0299



NOTE!
 Please see the *Duct Kit Instruction Manual, 175R5640*, for further information

External ducts

If additional duct work is added externally to the Rittal cabinet, the pressure drop in the ducting must be calculated. Please see the section *Cooling and Airflow* for further information.

3.3.2 Installation of Top-only Duct Cooling Kit

This description is for the installation of the top section only of the backchannel cooling kits available for frame sizes D3, D4 and E2. In addition to the enclosure, an 8 in [200 mm] vented pedestal is required.

The minimum enclosure depth is 19.7 in [500 mm] (23.6 in [600 mm] for E2 frame) and the minimum enclosure width is 23.6 in [600 mm] (31.5 in [800 mm] for E2 frame). The maximum depth and width are as required for the installation. When using multiple adjustable frequency drives in one enclosure mount each drive on its own back panel and support along the mid-section of the panel. The back-channel cooling kits are very similar in construction for all frames. The D3 and D4 kits do not support "in frame" mounting of the adjustable frequency drives. The E2 kit is mounted "in frame" for additional support of the adjustable frequency drive.

Using these kits as described removes 85% of the losses via the backchannel using the drive's main heatsink fan. The remaining 15% must be removed via the door of the enclosure.



NOTE!
 Please see the *Top-Only Backchannel Cooling Kit Instruction, 175R1107*, for further information

Ordering information

Frame size D3 and D4: 176F1775
 Frame size E2: 176F1776

3.3.3 Installation of Top and Bottom Covers for Rittal Enclosures

The top and bottom covers, installed onto IP00 adjustable frequency drives, direct the heatsink cooling air in and out the back of the adjustable frequency drive. The kits are applicable to IP00 drive frames D3, D4 and E2. These kits are designed and tested to be used with IP00/Chassis drives in Rittal TS8 enclosures.

Notes:

1. If external duct work is added to the exhaust path of the drive, additional back pressure will be created that will reduce the cooling of the drive. The drive must be derated to accommodate the reduced cooling. First, the pressure drop must be calculated, then refer to the derating tables located earlier in this section.
2. A door fan is required on the enclosure to remove the heat losses not contained in the backchannel of the drive and any additional losses generated from other components installed inside the enclosure. The total required air flow must be calculated so that the appropriate fans can be selected. Some enclosure manufacturers offer software for performing the calculations (i.e., Rittal Therm software).
If the adjustable frequency drive is the only heat generating component in the enclosure, the minimum airflow required at an ambient temperature of 113°F [45°C] for the D3 and D4 frame drives is 391 m³/h (230 cfm). The minimum airflow required at an ambient temperature of 113°F [45°C] for the E2 frame drive is 782 m³/h (460 cfm).



NOTE!

Please see the instruction for *Top and Bottom Covers - Rittal Enclosure, 177R0076*, for further information

Ordering information

Frame size D3: 176F1781

Frame size D4: 176F1782

Frame size E2: 176F1783

3.3.4 Installation of Top and Bottom Covers

Top and bottom covers can be installed on frame sizes D3, D4 and E2. These kits are designed to be used to direct the backchannel airflow in and out the back of the drive as opposed to in the bottom and out the top of the drive (when the drives are being mounted directly on a wall or inside a welded enclosure).

Notes:

1. If external duct work is added to the exhaust path of the drive, additional back pressure will be created that will reduce the cooling of the drive. The drive must be derated to accommodate the reduced cooling. First, the pressure drop must be calculated, then refer to the derating tables located earlier in this section.
2. A door fan is required on the enclosure to remove the heat losses not contained in the backchannel of the drive and any additional losses generated from other components installed inside the enclosure. The total required air flow must be calculated so that the appropriate fans can be selected. Some enclosure manufacturers offer software for performing the calculations (i.e., Rittal Therm software).
If the adjustable frequency drive is the only heat generating component in the enclosure, the minimum airflow required at an ambient temperature of 113°F [45°C] for the D3 and D4 frame drives is 391 m³/h (230 cfm). The minimum airflow required at an ambient temperature of 113°F [45°C] for the E2 frame drive is 782 m³/h (460 cfm).



NOTE!

Please see the *Top and Bottom Covers Only Instruction, 175R1106*, for further information

Ordering information

Frame size D3 and D4: 176F1862

Frame size E2: 176F1861

3.3.5 Outside Installation/ NEMA 3R Kit for Rittal Enclosures



This section is for the installation of NEMA 3R kits available for the adjustable frequency drive frames D3, D4 and E2. These kits are designed and tested to be used with IP00/ Chassis versions of these frames in Rittal TS8 NEMA 3R or NEMA 4 enclosures. The NEMA-3R enclosure is an outdoor enclosure that provides a degree of protection against rain and ice. The NEMA-4 enclosure is an outdoor enclosure that provides a greater degree of protection against weather and hosed water.

The minimum enclosure depth is 19.7 in [500 mm] 23.6 in [600 mm] for E2 frame) and the kit is designed for a 23.6 in [600 mm] 31.5 in [800 mm] for E2 frame) wide enclosure. Other enclosure widths are possible, however additional Rittal hardware is required. The maximum depth and width are as required for the installation.

 **NOTE!**
The current rating of drives in D3 and D4 frames are de-rated by 3%, when adding the NEMA 3R kit. Drives in E2 frames require no derating

 **NOTE!**
A door fan is required on the enclosure to remove the heat losses not contained in the backchannel of the drive and any additional losses generated from other components installed inside the enclosure. The total required air flow must be calculated so that the appropriate fans can be selected. Some enclosure manufacturers offer software for performing the calculations (i.e., Rittal Therm software). If the VLT is the only heat generating component in the enclosure, the minimum airflow required at an ambient temperature of 113°F [45°C] for the D3 and D4 drives is 391 m³/h (230 cfm). The minimum airflow required at an ambient temperature of 113°F [45°C] for the E2 drive is 782 m³/h (460 cfm).

Ordering information

- Frame size D3: 176F4600
- Frame size D4: 176F4601
- Frame size E2: 176F1852

 **NOTE!**
Please see the instructions *175R5922* for further information

3.3.6 Outside Installation /NEMA 3R Kit of Industrial Enclosures

The kits are available for the frame sizes D3, D4 and E2. These kits are designed and tested to be used with IP00/Chassis drives in welded box construction enclosures with an environmental rating of NEMA-3R or NEMA-4. The NEMA-3R enclosure is a dust-tight, rain-tight, ice-resistant, outdoor enclosure. The NEMA-4 enclosure is a dust-tight and water-tight enclosure.

This kit has been tested and complies with UL environmental rating Type-3R.

Note: The current rating of D3 and D4 frame drives are de-rated by 3% when installed in a NEMA-3R enclosure. E2 frame drives require no de-rating when installed in a NEMA-3R enclosure.



NOTE!

Please see the instruction for *Outside Installation /NEMA 3R kit of industrial enclosures, 175R1068*, for further information

Ordering information

Frame size D3: 176F0296

Frame size D4: 176F0295

Frame size E2: 176F0298

3.3.7 Installation of IP00s D3 & D4 Terminal Cover

The terminal cover can be installed on frame sizes D3 and D4 (IP00).



NOTE!

Please see the instruction for *Installation of Terminal Cover, 175R1108*, for further information

Ordering information

Frame size D3/D4: 176F1779

3.3.8 Installation of IP00s D3, D4, & E2 Cable Clamp Bracket

The motor cable clamp brackets can be installed on frame sizes D3 and D4 (IP00).



NOTE!

Please see the instruction for *Cable Clamp Bracket Kit, 175R1109*, for further information

Ordering information

Frame size D3: 176F1774

Frame size D4: 176F1746

Frame size E2: 176F1745

3.3.9 Installation on Pedestal

This section describes the installation of a pedestal unit available for the adjustable frequency drives frames D1 and D2. This is an 8 in [200 mm] high pedestal that allows these frames to be floor mounted. The front of the pedestal has openings for input air to the power components.

The adjustable frequency drive connector plate must be installed to provide adequate cooling air to the control components of the adjustable frequency drive via the door fan and to maintain the IP21/NEMA 1 or IP54/NEMA 12 degrees of enclosure protections.



Figure 3.36: Drive on pedestal

There is one pedestal that fits both frames D1 and D2. Its ordering number is 176F1827. The pedestal is standard for E1 frame.

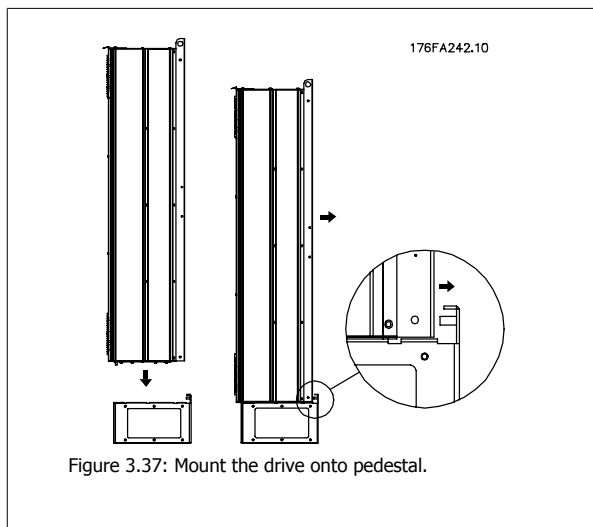

Figure 3.37: Mount the drive onto pedestal.



NOTE!

Please see the *Pedestal Kit Instruction Manual, 175R5642*, for further information.

3

3.3.10 Installation of Line Power Shield for Adjustable Frequency Drives

This section is for the installation of a line power shield for the adjustable frequency drive series with D1, D2 and E1 frames. It is not possible to install in the IP00/ Chassis versions as these have included as standard a metal cover. These shields satisfy VBG-4 requirements.

Ordering numbers:

Frames D1 and D2: 176F0799

Frame E1: 176F1851

NOTE!
For further information, please see the Instruction Sheet, *175R5923*

3.3.11 Installation of Input Plate Options

This section is for the field installation of input option kits available for adjustable frequency drives in all D and E frames. Do not attempt to remove RFI filters from input plates. Damage may occur to RFI filters if they are removed from the input plate.

NOTE!
Where RFI filters are available, there are two different types of RFI filters depending on the input plate combination and the RFI filters interchangeable. Field installable kits in certain cases are the same for all voltages.

	380–480 V 380–500 V	Fuses	Disconnect Fuses	RFI	RFI Fuses	RFI Disconnect Fuses
D1	All D1 power sizes	176F8442	176F8450	176F8444	176F8448	176F8446
D2	All D2 power sizes	176F8443	176F8441	176F8445	176F8449	176F8447
E1	FC 102/ : 450 hp [315 kW]	176F0253	176F0255	176F0257	176F0258	176F0260
	FC 302: 350 hp [250 kW]					
	FC 102/ : 500–600 hp [355–450 kW]	176F0254	176F0256	176F0257	176F0259	176F0262
	FC 302: 450–550 hp [315–400 kW]					

	525–690 V	Fuses	Disconnect Fuses	RFI	RFI Fuses	RFI Disconnect Fuses
D1	FC 102/ : 60–125 hp [45–90 kW] FC 302: 50–100 hp [37– 75 kW]	175L8829	175L8828	175L8777	NA	NA
	FC 102/ : 150–215 hp [110–160 kW] FC 302: 120–180 hp [90– 132 kW]	175L8442	175L8445	175L8777	NA	NA
D2	All D2power sizes	175L8827	175L8826	175L8825	NA	NA
E1	FC 102/ : 600–670 hp [450–500 kW] FC 302: 500–600 hp [355–400 kW]	176F0253	176F0255	NA	NA	NA
	FC 102/ : 750–850 hp [560–630 kW] FC 302: 675–750 hp [500–560 kW]	176F0254	176F0258	NA	NA	NA

NOTE!
For further information, please see the Instruction Sheet, *175R5795*

3.3.12 Installation of D1, D2, D3, & D4 Loadshare Option

The loadshare option can be installed on frame sizes D1, D2, D3 and D4.

NOTE!
Please see the *Loadshare Terminal Kit Instructions, 175R5637*, for further information

Ordering information

Frame size D1/D3: 176F8456

Frame size D2/D4: 176F8455

3.4.1 Frame Size F Panel Options

Space Heaters and Thermostat

Mounted on the cabinet interior of frame size F adjustable frequency drives, space heaters controlled via automatic thermostat help control humidity inside the enclosure, extending the lifetime of drive components in damp environments. The thermostat default settings turn on the heaters at 10°C (50°F) and turn them off at 15.6°C (60°F).

Cabinet Light with Power Outlet

A light mounted on the cabinet interior of frame size F adjustable frequency drives increase visibility during servicing and maintenance. The housing light includes a power outlet for temporarily powering tools or other devices, available in two voltages:

- 230 V, 50 Hz, 2.5 A, CE/ENEC
- 120 V, 60 Hz, 5 A, UL/cUL

Transformer Tap Set-up

If the Cabinet Light & Outlet and/or the Space Heaters & Thermostat are installed Transformer T1 requires it taps to be set to the proper input voltage. A 380–480/500 V380–480 V drive will initially be set to the 525 V tap and a 525–690 V drive will be set to the 690 V tap to insure no overvoltage of secondary equipment occurs if the tap is not changed prior to power being applied. See the table below to set the proper tap at terminal T1 located in the rectifier cabinet. For location in the drive, see figure of rectifier in the *Power Connections* section.

Input Voltage Range	Tap to Select
380–440 V	400V
441–490 V	460V
491–550 V	525V
551–625 V	575V
626–660 V	660V
661–690 V	690V

3

NAMUR Terminals

NAMUR is an international association of automation technology users in process industries, primarily in the chemical and pharmaceutical industries, in Germany. Selection of this option provides terminals organized and labeled to the specifications of the NAMUR standard for drive input and output terminals. This requires MCB 112 PTC Thermistor Card and MCB 113 Extended Relay Card.

RCD (Residual Current Device)

Uses the core balance method to monitor ground fault currents in grounded and high-resistance grounded systems (TN and TT systems in IEC terminology). There is a pre-warning (50% of main alarm setpoint) and a main alarm setpoint. Associated with each setpoint is an SPDT alarm relay for external use. Requires an external "window-type" current transformer (supplied and installed by customer).

- Integrated into the drive's safe-stop circuit
- IEC 60755 Type B device monitors AC, pulsed DC, and pure DC ground fault currents
- LED bar graph indicator of the ground fault current level from 10–100% of the setpoint
- Fault memory
- TEST / RESET button

Insulation Resistance Monitor (IRM)

Monitors the insulation resistance in ungrounded systems (IT systems in IEC terminology) between the system phase conductors and ground. There is an ohmic pre-warning and a main alarm setpoint for the insulation level. Associated with each setpoint is an SPDT alarm relay for external use. Note: only one insulation resistance monitor can be connected to each ungrounded (IT) system.

- Integrated into the drive's safe-stop circuit
- LCD display of the ohmic value of the insulation resistance
- Fault Memory
- INFO, TEST, and RESET buttons

IEC Emergency Stop with Pilz Safety Relay

Includes a redundant 4-wire emergency stop pushbutton mounted on the front of the enclosure and a Pilz relay that monitors it in conjunction with the drive's safe stop circuit and the line power contactor located in the options cabinet.

Manual Motor Starters

Provide 3-phase power for electric blowers often required for larger motors. Power for the starters is provided from the load side of any supplied contactor, circuit breaker, or disconnect switch. Power is fused before each motor starter, and is off when the incoming power to the drive is off. Up to two starters are allowed (one if a 30 A, fuse-protected circuit is ordered). Integrated into the drive's safe-stop circuit.

Unit features include:

- Operation switch (on/off)
- Short-circuit and overload protection with test function
- Manual reset function

30 Ampere, Fuse-protected Terminals

- 3-phase power matching incoming AC line voltage for powering auxiliary customer equipment
- Not available if two manual motor starters are selected

- Terminals are off when the incoming power to the drive is off
- Power for the fused protected terminals will be provided from the load side of any supplied contactor, circuit breaker, or disconnect switch.

24 VDC Power Supply

- 5 amp, 120 W, 24 VDC
- Protected against output overcurrent, overload, short circuits, and overtemperature
- For powering customer-supplied accessory devices such as sensors, PLC I/O, contactors, temperature probes, LEDs, and/or other electronic hardware
- Diagnostics include a dry DC-ok contact, a green DC-ok LED, and a red overload LED

External Temperature Monitoring

Designed for monitoring temperatures of external system components, such as the motor windings and/or bearings. Includes eight universal input modules plus two dedicated thermistor input modules. All ten modules are integrated into the drive's safe stop circuit and can be monitored via a serial communication bus network (requires the purchase of a separate module/bus coupler).

Universal inputs (8)

Signal types:

- RTD inputs (including Pt100), 3-wire or 4-wire
- Thermocouple
- Analog current or analog voltage

Additional features:

- One universal output, configurable for analog voltage or analog current
- Two output relays (N.O.)
- Dual-line LC display and LED diagnostics
- Sensor lead wire break, short-circuit, and incorrect polarity detection
- Interface set-up software

Dedicated thermistor inputs (2)

Features:

- Each module is capable of monitoring up to six thermistors in a series
- Fault diagnostics for wire breakage or short-circuits of sensor leads
- ATEX/UL/CSA certification
- A third thermistor input can be provided by the PTC thermistor option card MCB 112, if necessary.

3.5 Electrical Installation

3.5.1 Power Connections

Cabling and Fusing



NOTE!

Cables General

All cabling must comply with national and local regulations on cable cross-sections and ambient temperature. UL applications require 167°F [75°C] copper conductors. 167°F [75°C] and 194°F [90°C] copper conductors are thermally acceptable for the adjustable frequency drive to use in non-UL applications.

The power cable connections are situated as shown below. Dimensioning of cable cross-section must be done in accordance with the current ratings and local legislation. See the *Specifications section* for details.

For protection of the adjustable frequency drive, the recommended fuses must be used or the unit must be with built-in fuses. Recommended fuses can be seen in the tables of the fuse section. Always ensure that proper fusing is done according to local regulations.

The AC line input connections are fitted to the line power switch if this is included.

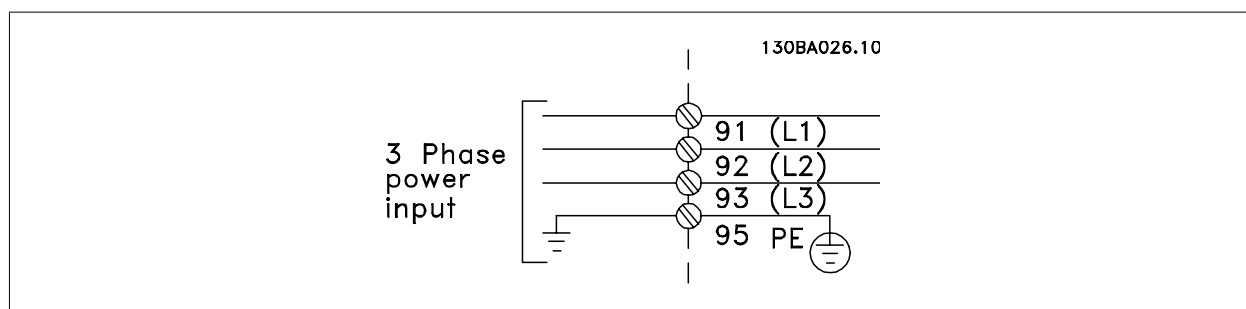

NOTE!

The motor cable must be shielded/armored. If an unshielded/unarmored cable is used, some EMC requirements are not complied with. Use a shielded/armored motor cable to comply with EMC emission specifications. For more information, see *EMC specifications* in the *Design Guide*.

See section General Specifications for correct dimensioning of motor cable cross-section and length.

Shielding of cables:

Avoid installation with twisted shield ends (pigtailed). They spoil the shielding effect at higher frequencies. If it is necessary to break the shield to install a motor isolator or motor contactor, the shield must be continued at the lowest possible HF impedance.

Connect the motor cable shield to both the de-coupling plate of the adjustable frequency drive and to the metal housing of the motor.

Make the shield connections with the largest possible surface area (cable clamp). This is done by using the supplied installation devices within the adjustable frequency drive.

Cable-length and cross-section:

The adjustable frequency drive has been EMC tested with a given length of cable. Keep the motor cable as short as possible to reduce the noise level and leakage currents.

Switching frequency:

When adjustable frequency drives are used together with sine-wave filters to reduce the acoustic noise from a motor, the switching frequency must be set according to the instructions in par. 14-01 *Switching Frequency*.

Term. no.	96	97	98	99	
	U	V	W	PE ¹⁾	Motor voltage 0–100% of AC line voltage. 3 wires out of motor
	U1 W2	V1 U2	W1 V2	PE ¹⁾	Delta-connected 6 wires out of motor
	U1	V1	W1	PE ¹⁾	Star-connected U2, V2, W2 U2, V2 and W2 to be interconnected separately.

1) Protected Ground Connection

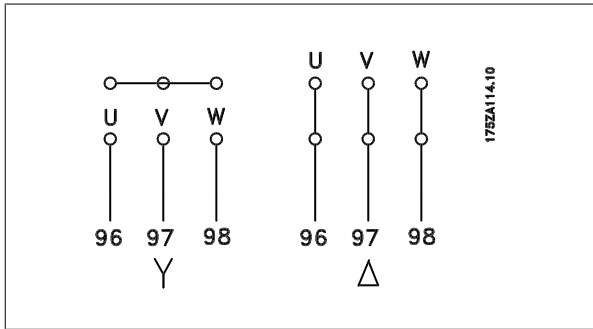

NOTE!
 In motors without phase insulation paper or other insulation reinforcement suitable for operation with voltage supply (such as an adjustable frequency drive), fit a sine-wave filter on the output of the adjustable frequency drive.

3

3

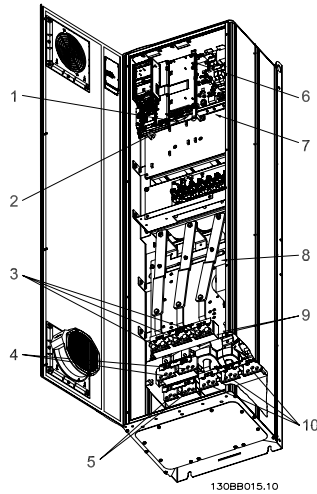

Figure 3.38: Compact IP 21 (NEMA 1) and IP 54 (NEMA 12), frame size D1

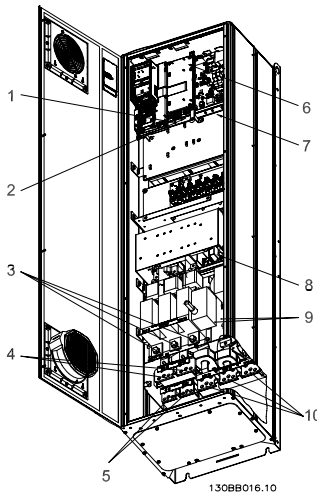

Figure 3.39: Compact IP 21 (NEMA 1) and IP 54 (NEMA 12) with disconnect, fuse and RFI filter, frame size D2

1) AUX Relay	5) Brake
01 02 03	-R +R
04 05 06	81 82
2) Temp Switch	6) SMPS Fuse (see fuse tables for part number)
106 104 105	7) AUX Fan
3) Line	100 101 102 103
R S T	L1 L2 L1 L2
91 92 93	8) Fan Fuse (see fuse tables for part number)
L1 L2 L3	9) Line power ground
4) Load sharing	10) Motor
-DC +DC	U V W
88 89	96 97 98
	T1 T2 T3

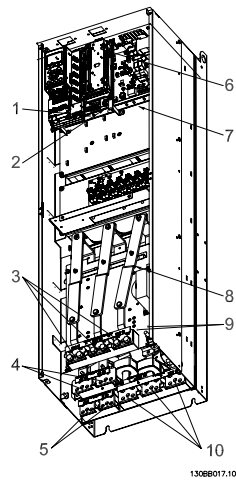

Figure 3.40: Compact IP 00 (Chassis), frame size D3

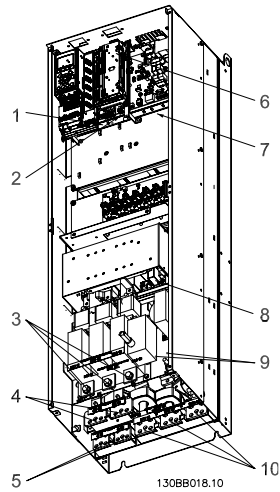
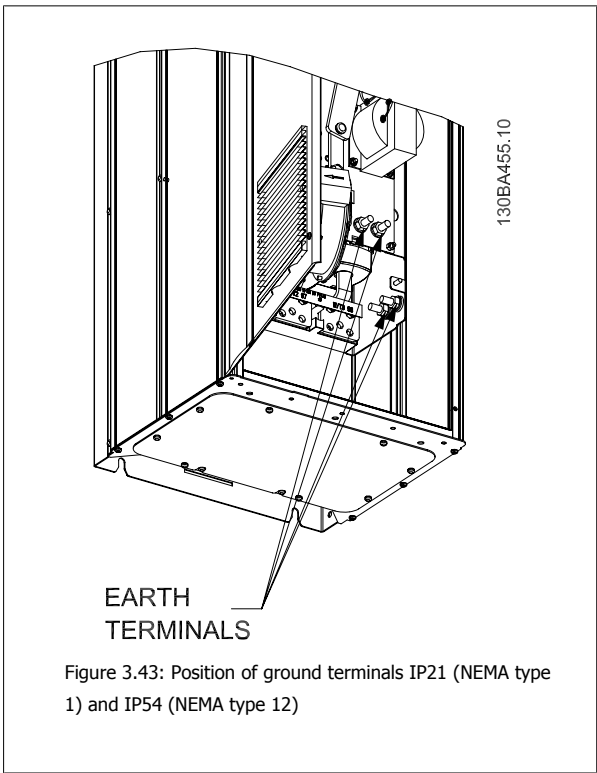
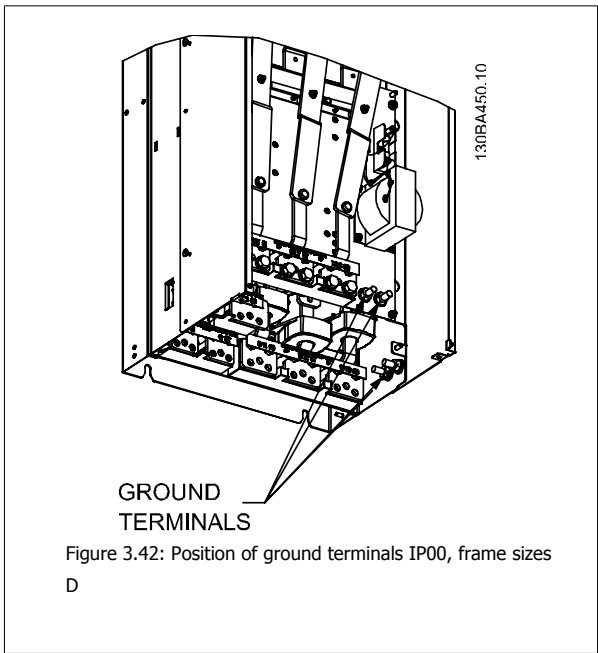



Figure 3.41: Compact IP 00 (Chassis) with disconnect, fuse and RFI filter, frame size D4

3

1) AUX Relay	01	02	03	04	05	06
2) Temp Switch	106	104	105			
3) Line	R	S	T			
	91	92	93			
	L1	L2	L3			
4) Load sharing	-DC	+DC				
	88	89				
5) Brake	-R	+R				
	81	82				
6) SMPS Fuse (see fuse tables for part number)						
7) AUX Fan	100	101	102	103		
	L1	L2	L1	L2		
8) Fan Fuse (see fuse tables for part number)						
9) Line power ground						
10) Motor	U	V	W			
	96	97	98			
	T1	T2	T3			



 **NOTE!**
D2 and D4 shown as examples. D1 and D3 are equivalent.

3

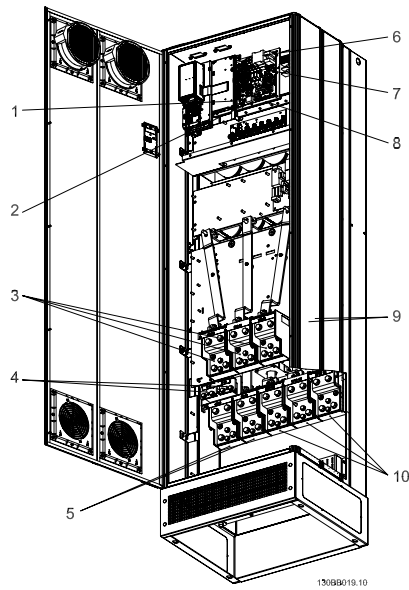

Figure 3.44: Compact IP 21 (NEMA 1) and IP 54 (NEMA 12) frame size E1

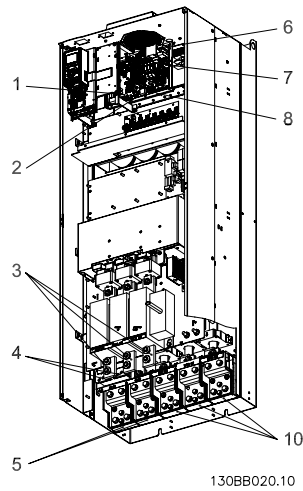
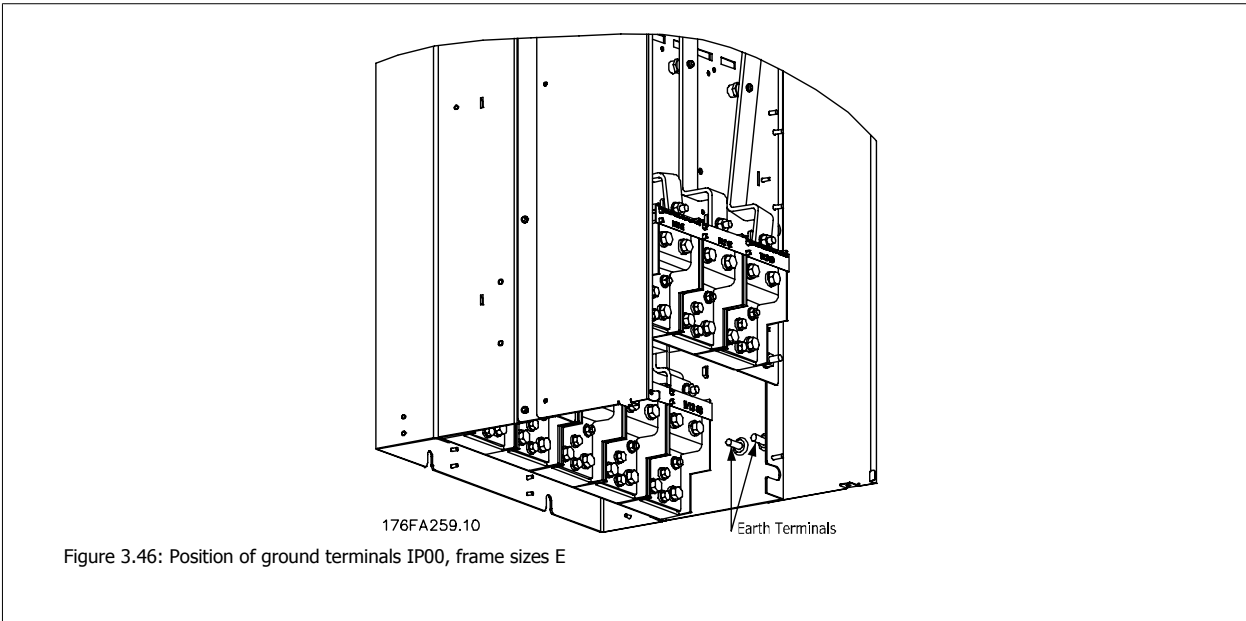

Figure 3.45: Compact IP 00 (Chassis) with disconnect, fuse and RFI filter, frame size E2

3

1) AUX Relay	01	02	03	5) Load sharing	-DC	+DC
	04	05	06		88	89
2) Temp Switch	106	104	105	6) SMPS Fuse (see fuse tables for part number)		
3) Line	R	S	T	7) Fan Fuse (see fuse tables for part number)		
	91	92	93	8) AUX Fan	100	101 102 103
	L1	L2	L3		L1	L2 L1 L2
4) Brake	-R	+R		9) Line power ground		
	81	82		10) Motor	U	V W
					96	97 98
					T1	T2 T3



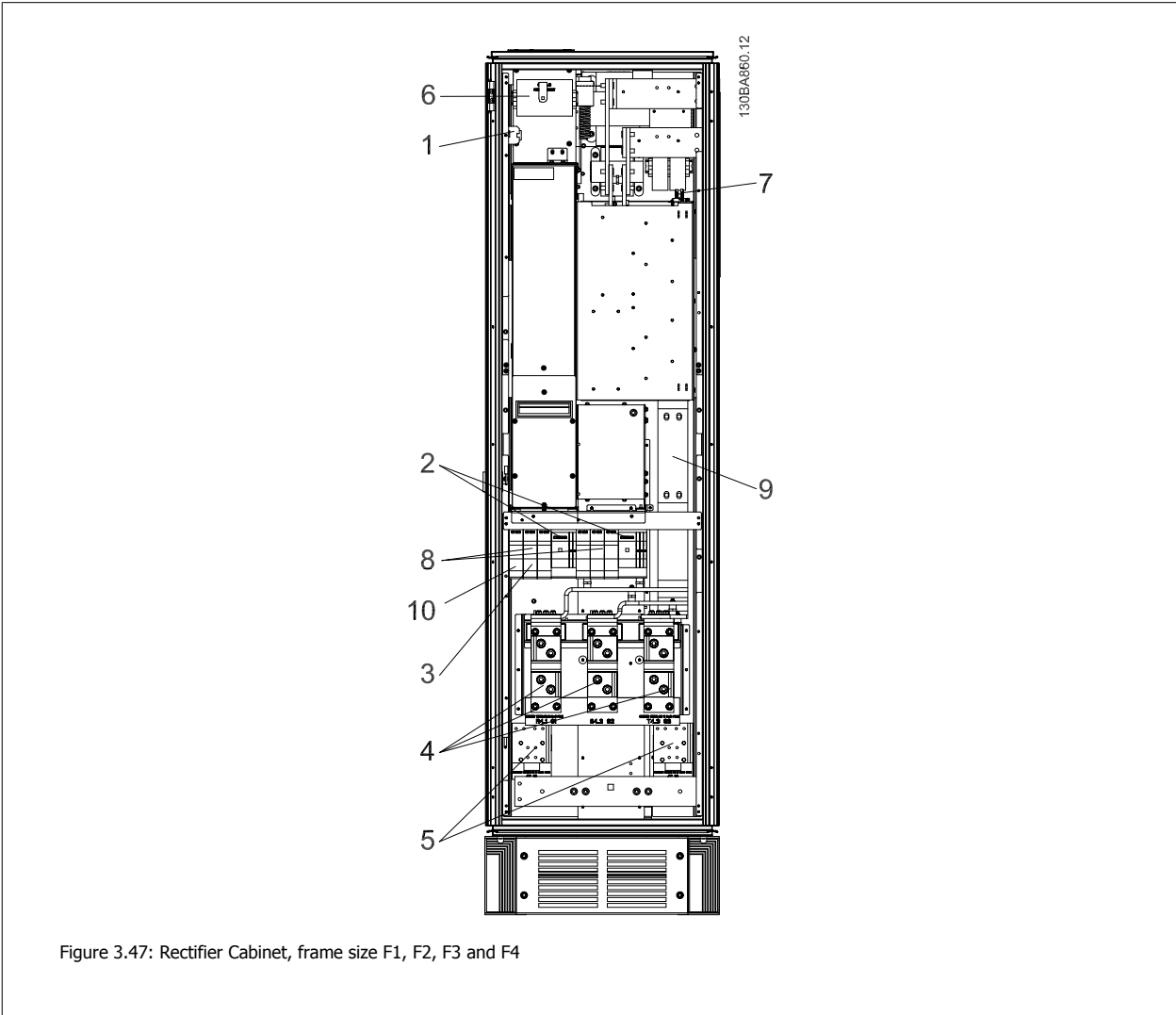

Figure 3.47: Rectifier Cabinet, frame size F1, F2, F3 and F4

- | | |
|---|---|
| <p>1) 24 V DC, 5 A
T1 Output Taps
Temp Switch
106 104 105</p> <p>2) Manual Motor Starters</p> <p>3) 30 A Fuse Protected Power Terminals</p> <p>4) Line
R S T
L1 L2 L3</p> | <p>5) Loadsharing
-DC +DC
88 89</p> <p>6) Control Transformer Fuses (2 or 4 pieces). See fuse tables for part numbers</p> <p>7) SMPS Fuse. See fuse tables for part numbers</p> <p>8) Manual Motor Controller fuses (3 or 6 pieces). See fuse tables for part numbers</p> <p>9) Line Fuses, F1 and F2 frame (3 pieces). See fuse tables for part numbers</p> <p>10) 30 Amp Fuse Protected Power fuses</p> |
|---|---|

3

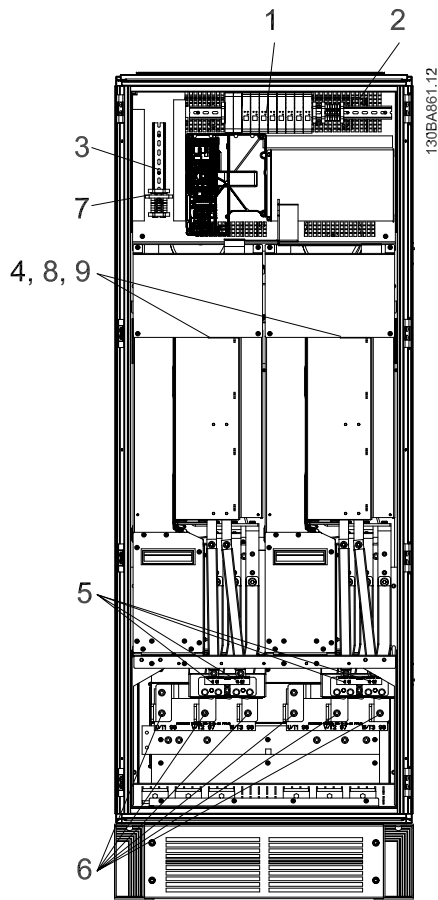

Figure 3.48: Inverter Cabinet, frame size F1 and F3

- | | |
|------------------------------------|---|
| 1) External Temperature Monitoring | 6) Motor |
| 2) AUX Relay | U V W |
| 01 02 03 | 96 97 98 |
| 04 05 06 | T1 T2 T3 |
| 3) NAMUR | 7) NAMUR Fuse. See fuse tables for part numbers |
| 4) AUX Fan | 8) Fan Fuses. See fuse tables for part numbers |
| 100 101 102 103 | 9) SMPS Fuses. See fuse tables for part numbers |
| L1 L2 L1 L2 | |
| 5) Brake | |
| -R +R | |
| 81 82 | |

3

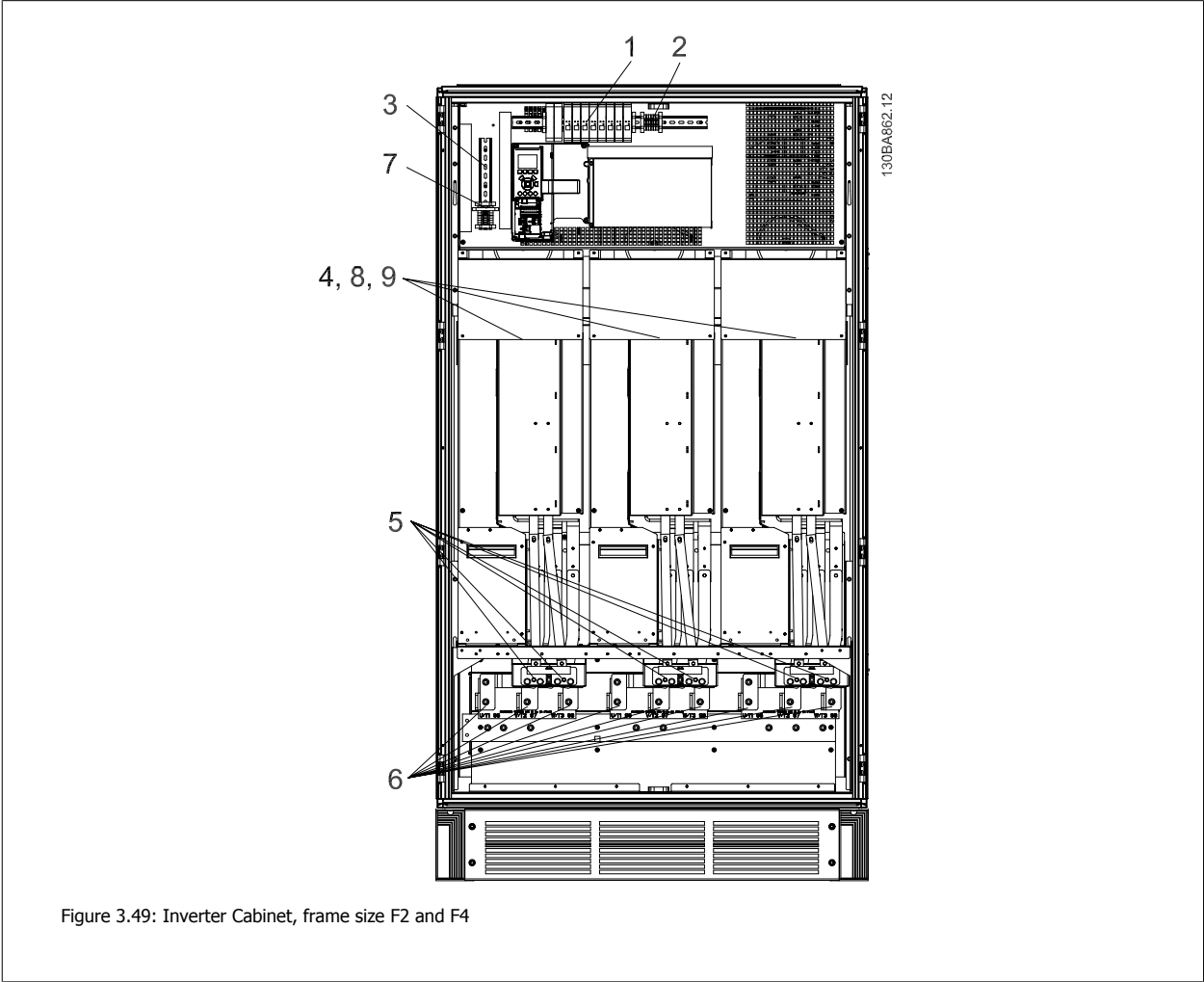

Figure 3.49: Inverter Cabinet, frame size F2 and F4

1) External Temperature Monitoring	6) Motor
2) AUX Relay	U V W
01 02 03	96 97 98
04 05 06	T1 T2 T3
3) NAMUR	7) NAMUR Fuse. See fuse tables for part numbers
4) AUX Fan	8) Fan Fuses. See fuse tables for part numbers
100 101 102 103	9) SMPS Fuses. See fuse tables for part numbers
L1 L2 L1 L2	
5) Brake	
-R +R	
81 82	

3

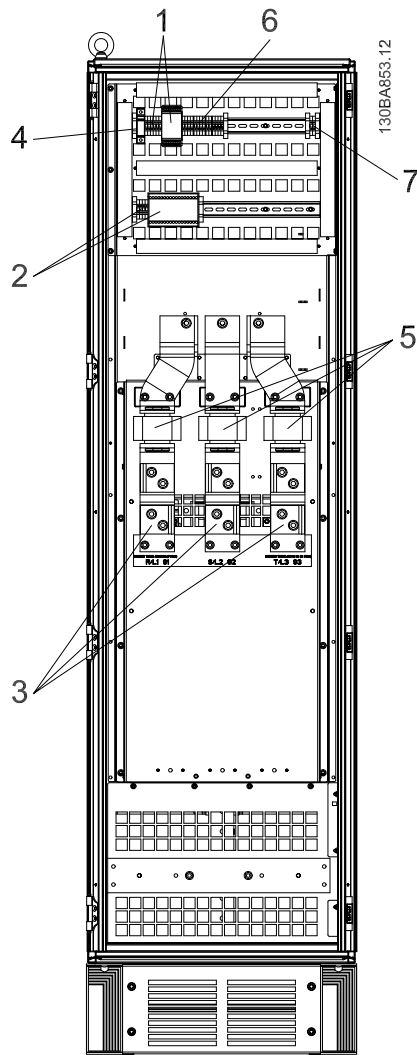

Figure 3.50: Options Cabinet, frame size F3 and F4

- | | |
|---|---|
| <p>1) Pilz Relay Terminal</p> <p>2) RCD or IRM Terminal</p> <p>3) Line power</p> <p style="padding-left: 20px;">R S T</p> <p style="padding-left: 20px;">91 92 93</p> <p style="padding-left: 20px;">L1 L2 L3</p> | <p>4) Safety Relay Coil Fuse with PILS Relay</p> <p style="padding-left: 20px;">See fuse tables for part numbers</p> <p>5) Line Fuses, F3 and F4 (3 pieces)</p> <p style="padding-left: 20px;">See fuse tables for part numbers</p> <p>6) Contactor Relay Coil (230 V AC). N/C and N/O Aux Contacts</p> <p>7) Circuit Breaker Shunt Trip Control Terminals (230 V AC or 230 V DC)</p> |
|---|---|

3.5.2 Grounding

The following basic issues need to be considered when installing an adjustable frequency drive, so as to obtain electromagnetic compatibility (EMC).

- Safety grounding: Please note that the adjustable frequency drive has a high leakage current and must be grounded appropriately for safety reasons. Always follow local safety regulations.
- High-frequency grounding: Keep the ground wire connections as short as possible.

Connect the different ground systems at the lowest possible conductor impedance. The lowest possible conductor impedance is obtained by keeping the conductor as short as possible and by using the greatest possible surface area.

The metal cabinets of the different devices are mounted on the cabinet rear plate using the lowest possible HF impedance. This prevents having different HF voltages for the individual devices and prevents the risk of radio interference currents running in connection cables that may be used between the devices, as radio interference is reduced.

In order to obtain a low HF impedance, use the fastening bolts of the devices as HF connections to the rear plate. It is necessary to remove insulating paint and the like from the fastening points.

3.5.3 Extra Protection (RCD)

ELCB relays, multiple protective grounding or grounding can be used as extra protection, provided that local safety regulations are complied with.

In the case of a ground fault, a DC component may develop in the fault current.

If ELCB relays are used, local regulations must be observed. Relays must be suitable for protection of 3-phase equipment with a bridge rectifier and for a brief discharge on power-up.

See also the section *Special Conditions* in the Design Guide.

3.5.4 RFI Switch

Line power supply isolated from ground

If the adjustable frequency drive is supplied from an isolated line power source (IT line power, floating delta and grounded delta) or TT/TN-S line power with grounded leg, the RFI switch is recommended to be turned off (OFF) ¹⁾ via par. 14-50 *RFI 1*. For further reference, see IEC 364-3. In case optimum EMC performance is needed, parallel motors are connected or the motor cable length is above 82 ft [25 m], it is recommended to set par. 14-50 *RFI 1* to [ON].

¹⁾ Not available for 525–600/690 V adjustable frequency drives in frame sizes D, E and F.

In OFF, the internal RFI capacities (filter capacitors) between the chassis and the intermediate circuit are cut off to avoid damage to the intermediate circuit and to reduce the ground capacity currents (according to IEC 61800-3).

Please also refer to the application note *VLT on IT line power, MN.90.CX.02*. It is important to use isolation monitors that are capable for use together with power electronics (IEC 61557-8).

3

3.5.5 Torque

When tightening all electrical connections, it is very important to tighten with the correct torque. Too low or too high torque results in a bad electrical connection. Use a torque wrench to ensure correct torque.

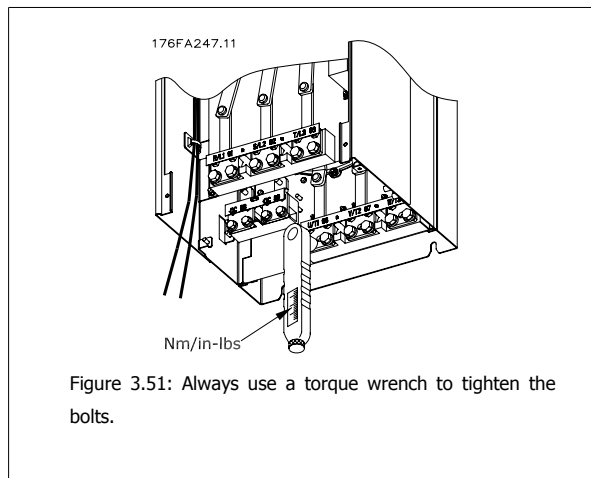

Frame size	Terminal	Torque	Bolt size
D1, D2, D3 and D4	Line power	19 Nm (168 in-lbs)	M10
	Motor		
	Load sharing	9.5 Nm (84 in-lbs)	M8
	Brake		
E1 and E2	Line power	19 NM (168 in-lbs)	M10
	Motor		
	Load sharing	9.5 Nm (84 in-lbs)	M8
	Brake		
F1, F2, F3 and F4	Line power	19 Nm (168 in-lbs)	M10
	Motor		
	Load sharing	19 Nm (168 in-lbs)	M10
	Brake		
	Regen	9.5 Nm (84 in-lbs)	M8
	19 Nm (168 in-lbs)	M10	

Table 3.4: Torque for terminals

3.5.6 Shielded Cables

It is important that shielded and armored cables are connected properly to ensure high EMC immunity and low emissions.

Connection can be made using either cable connectors or clamps:

- EMC cable connectors: Generally available cable connectors can be used to ensure an optimum EMC connection.
- EMC cable clamp: Clamps allowing for easy connection are supplied with the adjustable frequency drive.

3.5.7 Motor Cable

The motor must be connected to terminals U/T1/96, V/T2/97, W/T3/98. Ground to terminal 99. All types of three-phase asynchronous standard motors can be used with an adjustable frequency drive unit. The factory setting is for clockwise rotation with the adjustable frequency drive output connected as follows:

Terminal No.	Function
96, 97, 98, 99	Line power U/T1, V/T2, W/T3 Ground

3

- Terminal U/T1/96 connected to U-phase
- Terminal V/T2/97 connected to V-phase
- Terminal W/T3/98 connected to W-phase

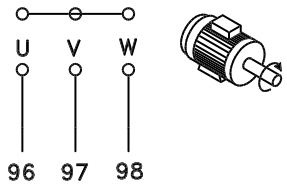
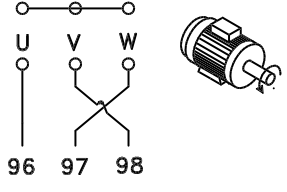
175HA35.00

The direction of rotation can be changed by switching two phases in the motor cable or by changing the setting of par. 4-10 *Motor Speed Direction*. Motor rotation check can be performed using par. 1-28 *Motor Rotation Check* and following the steps shown in the display.

F frame Requirements

F1/F3 requirements: Motor phase cable quantities must be multiples of 2, resulting in 2, 4, 6, or 8 (1 cable is not allowed) to obtain equal amount of wires attached to both inverter module terminals. The cables are required to be equal length within 10% between the inverter module terminals and the first common point of a phase. The recommended common point is the motor terminals.

F2/F4 requirements: Motor phase cable quantities must be multiples of 3, resulting in 3, 6, 9, or 12 (1 or 2 cables are not allowed) to obtain equal amount of wires attached to each inverter module terminal. The wires are required to be equal length within 10% between the inverter module terminals and the first common point of a phase. The recommended common point is the motor terminals.

Output junction box requirements: The length, minimum 8 ft [2.5 m], and quantity of cables must be equal from each inverter module to the common terminal in the junction box.



NOTE!
If a retrofit application requires unequal amounts of wires per phase, please consult the factory for requirements and documentation or use the top/bottom entry side cabinet option.

3

3.5.8 Brake Cable Drives with Factory Installed Brake Chopper Option

(Only standard with letter B in position 18 of typecode).

The connection cable to the brake resistor must be shielded and the max. length from the adjustable frequency drive to the DC bar is limited to 82 feet [25 m].

Terminal No.	Function
81, 82	Brake resistor terminals

The connection cable to the brake resistor must be shielded. Connect the shield by means of cable clamps to the conductive backplate at the adjustable frequency drive and to the metal cabinet of the brake resistor.

Size the brake cable cross-section to match the brake torque. See also *Brake Instructions, MI.90.Fx.yy* and *MI.50.Sx.yy* for further information regarding safe installation.



Please note that voltages up to 1099 V DC, depending on the supply voltage, may occur on the terminals.

F Frame Requirements

The brake resistor(s) must be connected to the brake terminals in each inverter module.

3.5.9 Load Sharing

Terminal No.	Function
88, 89	Loadsharing

The connection cable must be shielded and the max. length from the adjustable frequency drive to the DC bar is limited to 82 ft [25 m]. Load sharing enables the linking of the DC intermediate circuits of several adjustable frequency drives.



Please note that voltages up to 1099 V DC may occur on the terminals. Load sharing calls for extra equipment and safety considerations. For further information, see load sharing Instructions MI.50.NX.YY.



Please note that a line power disconnect may not isolate the adjustable frequency drive due to DC link connection

3.5.10 Shielding against Electrical Noise

Before mounting the line power cable, mount the EMC metal cover to ensure best EMC performance.

NOTE: The EMC metal cover is only included in units with an RFI filter.



Figure 3.52: Mount the EMC shield.

3.5.11 AC Line Input Connection

The line power supply must be connected to terminals 91, 92 and 93. Ground is connected to the terminal to the right of terminal 93.

Terminal No.	Function
91, 92, 93	Line power R/L1, S/L2, T/L3
94	Ground

3



Check the nameplate to ensure that the AC line voltage of the adjustable frequency drive matches the power supply of your plant.

Ensure that the power supply can supply the necessary current to the adjustable frequency drive.

If the unit is without built-in fuses, ensure that the appropriate fuses have the correct current rating.

3.5.12 External Fan Supply

Frame size D-E-F

If the adjustable frequency drive is supplied by DC or if the fan must run independently of the power supply, an external power supply can be applied. The connection is made on the power card.

Terminal No.	Function
100, 101	Auxiliary supply S, T
102, 103	Internal supply S, T

The connector located on the power card provides the AC line voltage connection for the cooling fans. The fans are factory-equipped to be supplied from a common AC line (jumpers between 100-102 and 101-103). If an external supply is needed, the jumpers are removed and the supply is connected to terminals 100 and 101. A 5 Amp fuse should be used for protection. In UL applications, this should be a LittleFuse KLK-5 or equivalent.

3.5.13 Fuses

Branch circuit protection:

In order to protect the installation against electrical and fire hazard, all branch circuits in an installation, switch gear, machines, etc., must be short-circuited and overcurrent protected according to national/international regulations.

Short-circuit protection:

The adjustable frequency drive must be protected against short-circuit to avoid electrical or fire hazard. Danfoss recommends using the fuses mentioned below to protect service personnel and equipment in case of an internal failure in the drive. The adjustable frequency drive provides full short-circuit protection in case of a short-circuit on the motor output.

Overcurrent protection

Provide overload protection to avoid fire hazard due to overheating of the cables in the installation. The adjustable frequency drive is equipped with internal overcurrent protection that can be used for upstream overload protection (UL applications excluded). See par. 4-18 *Current Limit*. Moreover, fuses or circuit breakers can be used to provide the overcurrent protection in the installation. Overcurrent protection must always be carried out according to national regulations.

Non-UL compliance

If UL/cUL is not to be complied with, we recommend using the following fuses, which will ensure compliance with EN50178:
In case of malfunction, not following the recommendation may result in unnecessary damage to the adjustable frequency drive.

P90 - P200	380–500 V	type gG
P250 - P400	380–500 V	type gR

UL compliance

380–500 V, frame sizes D, E and F

The fuses below are suitable for use on a circuit capable of delivering 100,000 Arms (symmetrical), 240 V, or 480 V, or 500 V, or 600 V depending on the drive voltage rating. With the proper fusing, the drive Short Circuit Current Rating (SCCR) is 100,000 Arms.

Size/ Type	Bussmann E1958 JFHR2**	Bussmann E4273 T/JDDZ**	SIBA E180276 JFHR2	LittelFuse E71611 JFHR2**	Ferraz- Shawmut E76491 JFHR2	Bussmann E4274 H/JDDZ**	Bussmann E125085 JFHR2*	Internal Option Bussmann
P90K	FWH- 300	JJS- 300	2061032. 315	L50S-300	6.6URD30D08A 0315	NOS- 300	170M3017	170M3018
P110	FWH- 350	JJS- 350	2061032. 35	L50S-350	6.6URD30D08A 0350	NOS- 350	170M3018	170M3018
P132	FWH- 400	JJS- 400	2061032. 4	L50S-400	6.6URD30D08A 0400	NOS- 400	170M4012	170M4016
P160	FWH- 500	JJS- 500	2061032. 5	L50S-500	6.6URD30D08A 0500	NOS- 500	170M4014	170M4016
P200	FWH- 600	JJS- 600	2062032. 63	L50S-600	6.6URD32D08A 630	NOS- 600	170M4016	170M4016

Table 3.5: Frame size D, Line fuses, 380-500 V

Size/Type	Bussmann PN*	Rating	Ferraz	Siba
P250	170M4017	700 A, 700 V	6.9URD31D08A0700	20 610 32.700
P315	170M6013	900 A, 700 V	6.9URD33D08A0900	20 630 32.900
P355	170M6013	900 A, 700 V	6.9URD33D08A0900	20 630 32.900
P400	170M6013	900 A, 700 V	6.9URD33D08A0900	20 630 32.900

Table 3.6: Frame size E, Line fuses, 380-500 V

Size/Type	Bussmann PN*	Rating	Siba	Internal Bussmann Option
P450	170M7081	1600 A, 700 V	20 695 32.1600	170M7082
P500	170M7081	1600 A, 700 V	20 695 32.1600	170M7082
P560	170M7082	2000 A, 700 V	20 695 32.2000	170M7082
P630	170M7082	2000 A, 700 V	20 695 32.2000	170M7082
P710	170M7083	2500 A, 700 V	20 695 32.2500	170M7083
P800	170M7083	2500 A, 700 V	20 695 32.2500	170M7083

Table 3.7: Frame size F, Line fuses, 380-500 V

Size/Type	Bussmann PN*	Rating	Siba
P450	170M8611	1100 A, 1000 V	20 781 32.1000
P500	170M8611	1100 A, 1000 V	20 781 32.1000
P560	170M6467	1400 A, 700 V	20 681 32.1400
P630	170M6467	1400 A, 700 V	20 681 32.1400
P710	170M8611	1100 A, 1000 V	20 781 32.1000
P800	170M6467	1400 A, 700 V	20 681 32.1400

Table 3.8: Frame size F, Inverter module DC Link Fuses, 380-500 V

*170M fuses from Bussmann shown use the -/80 visual indicator; -TN/80 Type T, -/110 or TN/110 Type T indicator fuses of the same size and amperage may be substituted for external use

**Any minimum 500 V UL listed fuse with associated current rating may be used to meet UL requirements.

525-690 V, frame sizes D, E and F

Size/Type	Bussmann E125085 JFHR2	Amps	SIBA E180276 JFHR2	Ferraz-Shawmut E76491 JFHR2	Internal Option Bussmann
P37K	170M3013	125	2061032.125	6.6URD30D08A0125	170M3015
P45K	170M3014	160	2061032.16	6.6URD30D08A0160	170M3015
P55K	170M3015	200	2061032.2	6.6URD30D08A0200	170M3015
P75K	170M3015	200	2061032.2	6.6URD30D08A0200	170M3015
P90K	170M3016	250	2061032.25	6.6URD30D08A0250	170M3018
P110	170M3017	315	2061032.315	6.6URD30D08A0315	170M3018
P132	170M3018	350	2061032.35	6.6URD30D08A0350	170M3018
P160	170M4011	350	2061032.35	6.6URD30D08A0350	170M5011
P200	170M4012	400	2061032.4	6.6URD30D08A0400	170M5011
P250	170M4014	500	2061032.5	6.6URD30D08A0500	170M5011
P315	170M5011	550	2062032.55	6.6URD32D08A550	170M5011

Table 3.9: Frame size D, 525-690 V

Size/Type	Bussmann PN*	Rating	Ferraz	Siba
P355	170M4017	700 A, 700 V	6.9URD31D08A0700	20 610 32.700
P400	170M4017	700 A, 700 V	6.9URD31D08A0700	20 610 32.700
P500	170M6013	900 A, 700 V	6.9URD33D08A0900	20 630 32.900
P560	170M6013	900 A, 700 V	6.9URD33D08A0900	20 630 32.900

Table 3.10: Frame size E, 525-690 V

Size/Type	Bussmann PN*	Rating	Siba	Internal Bussmann Option
P630	170M7081	1600 A, 700 V	20 695 32.1600	170M7082
P710	170M7081	1600 A, 700 V	20 695 32.1600	170M7082
P800	170M7081	1600 A, 700 V	20 695 32.1600	170M7082
P900	170M7081	1600 A, 700 V	20 695 32.1600	170M7082
P1M0	170M7082	2000 A, 700 V	20 695 32.2000	170M7082
P1M2	170M7083	2500A, 700V	20 695 32.2500	170M7083

Table 3.11: Frame size F, Line fuses, 525-690 V

Size/Type	Bussmann PN*	Rating	Siba
P630	170M8611	1100 A, 1000 V	20 781 32. 1000
P710	170M8611	1100 A, 1000 V	20 781 32. 1000
P800	170M8611	1100 A, 1000 V	20 781 32. 1000
P900	170M8611	1100 A, 1000 V	20 781 32. 1000
P1M0	170M8611	1100 A, 1000 V	20 781 32. 1000
P1M2	170M8611	1100A, 1000V	20 781 32.1000

Table 3.12: Frame size F, Inverter module DC Link Fuses, 525–690 V

*170M fuses from Bussmann shown use the -/80 visual indicator; -TN/80 Type T, -/110 or TN/110 Type T indicator fuses of the same size and amperage may be substituted for external use.

Suitable for use on a circuit capable of delivering not more than 100,000 rms symmetrical amperes, 500/600/690 Volts maximum when protected by the above fuses.

3

Supplementary fuses

Frame size	Bussmann PN*	Rating
D, E and F	KTK-4	4 A, 600 V

Table 3.13: SMPS Fuse

3

Size/Type	Bussmann PN*	Littelfuse	Rating
P90K-P250, 380–500 V	KTK-4		4 A, 600 V
P37K-P400, 525–690 V	KTK-4		4 A, 600 V
P315-P800, 380–500 V		KLK-15	15A, 600 V
P500-P1M2, 525–690 V		KLK-15	15A, 600 V

Table 3.14: Fan Fuses

	Size/Type	Bussmann PN*	Rating	Alternative Fuses
2.5–4.0 A Fuse	P450-P800, 380–500 V	LPJ-6 SP or SPI	6 A, 600 V	Any listed Class J Dual Element, Time Delay, 6 A
	P630-P1M2, 525–690 V	LPJ-10 SP or SPI	10 A, 600 V	Any listed Class J Dual Element, Time Delay, 10 A
4.0–6.3 A Fuse	P450-P800, 380–500 V	LPJ-10 SP or SPI	10 A, 600 V	Any listed Class J Dual Element, Time Delay, 10 A
	P630-P1M2, 525–690 V	LPJ-15 SP or SPI	15 A, 600 V	Any listed Class J Dual Element, Time Delay, 15 A
6.3–10 A Fuse	P450-P800600–1200 HP, 380–500 V	LPJ-15 SP or SPI	15 A, 600 V	Any listed Class J Dual Element, Time Delay, 20 A
	P630-P1M2, 525–690 V	LPJ-20 SP or SPI	20 A, 600 V	Any listed Class J Dual Element, Time Delay, 20 A
10–16 A Fuse	P450-P800, 380–500 V	LPJ-25 SP or SPI	25 A, 600 V	Any listed Class J Dual Element, Time Delay, 25 A
	P630-P1M2, 525–690 V	LPJ-20 SP or SPI	20 A, 600 V	Any listed Class J Dual Element, Time Delay, 20 A

Table 3.15: Manual Motor Controller Fuses

Frame size	Bussmann PN*	Rating	Alternative Fuses
F	LPJ-30 SP or SPI	30 A, 600 V	Any listed Class J Dual Element, Time Delay, 30 A

Table 3.16: 30 A Fuse Protected Terminal Fuse

Frame size	Bussmann PN*	Rating	Alternative Fuses
F	LPJ-6 SP or SPI	6 A, 600 V	Any listed Class J Dual Element, Time Delay, 6 A

Table 3.17: Control Transformer Fuse

Frame size	Bussmann PN*	Rating
F	GMC-800MA	800 mA, 250 V

Table 3.18: NAMUR Fuse

Frame size	Bussmann PN*	Rating	Alternative Fuses
F	LP-CC-6	6 A, 600 V	Any listed Class CC, 6 A

Table 3.19: Safety Relay Coil Fuse with PILS Relay

3.5.14 Line Power Disconnectors - Frame Size D, E and F

Frame size	Power & Voltage	Type
D1/D3	P90K-P110 380–500 V & P90K-P132 525–690 V	ABB OETL-NF200A or OT200U12-91
D2/D4	P132-P200 380–500 V & P160-P315 525–690 V	ABB OETL-NF400A or OT400U12-91
E1/E2	P250 380–500 V & P355-P560 525–690 V	ABB OETL-NF600A
E1/E2	P315-P400 380–500 V	ABB OETL-NF800A
F3	P450 380–500 V & P630-P710 525–690 V	Merlin Gerin NPJF36000S12AAYP
F3	P500-P630 380–500 V & P800 525–690 V	Merlin Gerin NRK36000S20AAYP
F4	P710-P800 380–500 V & P900-P1M2 525–690 V	Merlin Gerin NRK36000S20AAYP

3.5.15 F-Frame Circuit Breakers

Frame size	Power & Voltage	Type
F3	P450 380–500 V & P630-P710 525–690 V	Merlin Gerin NPJF36120U31AABSCYP
F3	P500-P630 380–500 V & P800 525–690 V	Merlin Gerin NRJF36200U31AABSCYP
F4	P710 380–500 V & P900-P1M2 525–690 V	Merlin Gerin NRJF36200U31AABSCYP
F4	P800 380–500 V	Merlin Gerin NRJF36250U31AABSCYP

3.5.16 F-Frame Line Power Contactors

Frame size	Power & Voltage	Type
F3	P450-P500 380–500 V & P630-P800 525–690 V	Eaton XTCE650N22A
F3	P560 380–500 V	Eaton XTCE820N22A
F3	P630 380–500 V	Eaton XTCEC14P22B
F4	P900 525–690 V	Eaton XTCE820N22A
F4	P710-P800 380–500 V & P1M2 525–690 V	Eaton XTCEC14P22B

3.5.17 Motor Insulation

For motor cable lengths \leq , the maximum cable length listed in the General Specifications tables the following motor insulation ratings are recommended because the peak voltage can be up to twice the DC link voltage, 2.8 times the AC line voltage, due to transmission line effects in the motor cable. If a motor has lower insulation rating, it is recommended to use a du/dt or sine-wave filter.

Nominal AC Line Voltage	Motor Insulation
$U_N \leq 420$ V	Standard $U_{LL} = 1300$ V
420 V < $U_N \leq 500$ V	Reinforced $U_{LL} = 1600$ V
500 V < $U_N \leq 600$ V	Reinforced $U_{LL} = 1800$ V
600 V < $U_N \leq 690$ V	Reinforced $U_{LL} = 2000$ V

3.5.18 Motor Bearing Currents

All motors installed with FC 302 125 hp [90 kW] or higher power drives should have NDE (Non-Drive End) insulated bearings installed to eliminate circulating bearing currents. To minimize DE (Drive End) bearing and shaft currents proper grounding of the drive, motor, driven machine, and motor to the driven machine is required.

Standard Mitigation Strategies:

1. Use an insulated bearing
2. Apply rigorous installation procedures
 - Ensure the motor and load motor are aligned
 - Strictly follow the EMC Installation guideline
 - Reinforce the PE so the high frequency impedance is lower in the PE than the input power leads.
 - Provide a good high frequency connection between the motor and the adjustable frequency drive for instance by shielded cable which has a 360° connection in the motor and the adjustable frequency drive.
 - Make sure that the impedance from adjustable frequency drive to building ground is lower than the grounding impedance of the machine. This can be difficult for pumps.
 - Make a direct ground connection between the motor and load motor.
3. Lower the IGBT switching frequency
4. Modify the inverter waveform, 60° AVM vs. SFAVM
5. Install a shaft grounding system or use an isolating coupling.
6. Apply conductive lubrication
7. Use minimum speed settings, if possible.
8. Try to ensure the line voltage is balanced to ground. This can be difficult for IT, TT, TN-CS or Grounded leg systems
9. Use a dU/dt or sinus filter

3.5.19 Brake Resistor Temperature Switch

Frame size D-E-F

Torque: 0.5–0.6 Nm (5 in-lbs)

Screw size: M3

This input can be used to monitor the temperature of an externally connected brake resistor. If the input between 104 and 106 is established, the adjustable frequency drive will trip on warning / alarm 27, "Brake IGBT". If the connection is closed between 104 and 105, the adjustable frequency drive will trip on warning/alarm 27, "Brake IGBT".

Normally closed: 104-106 (factory-installed jumper)

Normally open: 104-105

Terminal No.	Function
106, 104, 105	Brake resistor temperature switch.

If the temperature of the brake resistor gets too high and the thermal switch drops out, the adjustable frequency drive will stop braking. The motor will start coasting.

A KLIXON switch must be installed that is 'normally closed'. If this function is not used, 106 and 104 must be short-circuited together.

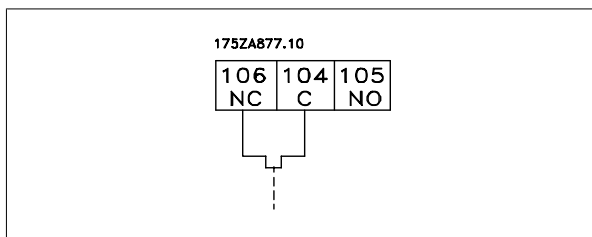

3.5.20 Control Cable Routing

Tie down all control wires to the designated control cable routing as shown in the picture. Remember to connect the shields in a proper way to ensure optimum electrical immunity.

Serial communication bus connection

Connections are made to the relevant options on the control card. For details, see the relevant serial communication bus instruction. The cable must be placed to the left inside the adjustable frequency drive and tied down together with other control wires (see picture).

3

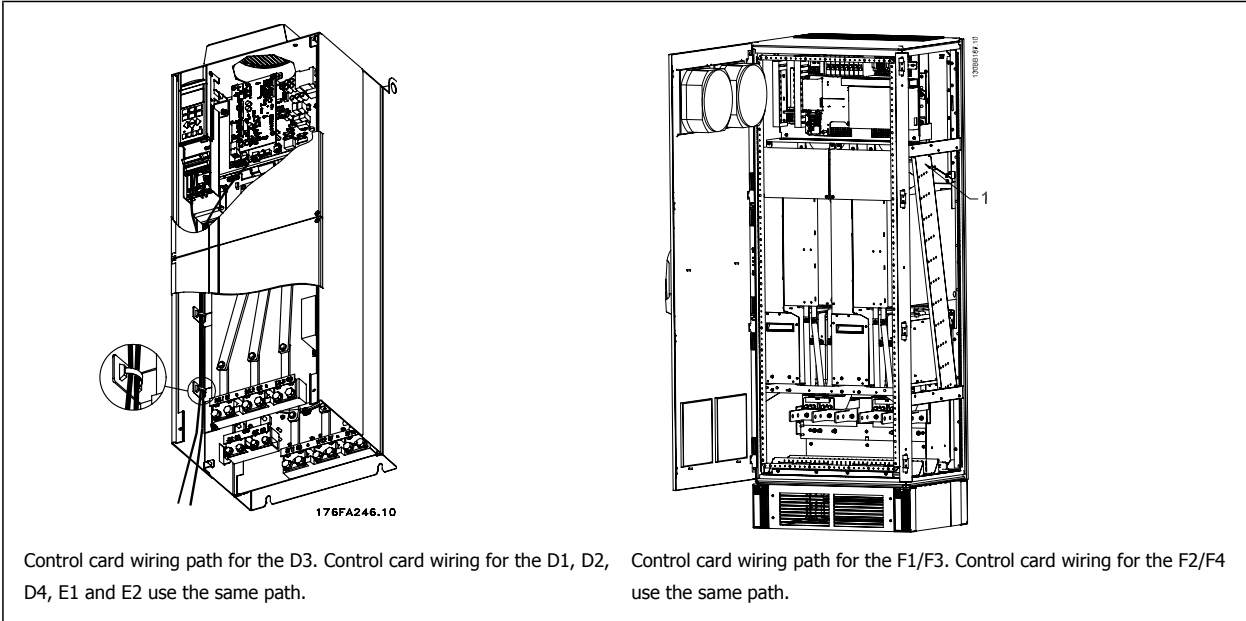

In the Chassis (IP00) and NEMA 1 units, it is also possible to connect the serial communication bus from the top of the unit as shown on the picture to the right. On the NEMA 1 unit, a cover plate must be removed. Kit number for serial communication bus top connection: 176F1742





3

Installation of 24 Volt external DC Supply

Torque: 0.5–0.6 Nm (5 in-lbs)

Screw size: M3

No.	Function
35 (-), 36 (+)	24 V external DC supply

24 VDC external supply can be used as low-voltage supply to the control card and any option cards installed. This enables full operation of the LCP (including parameter setting) without connection to line power. Please note that a warning of low voltage will be given when 24 V DC has been connected; however, there will be no tripping.

Use 24 V DC supply of type PELV to ensure correct galvanic isolation (type PELV) on the control terminals of the adjustable frequency drive.

3.5.21 Access to Control Terminals

All terminals to the control cables are located beneath the LCP. They are accessed by opening the door of the IP21/ 54 version or removing the covers of the IP00 version.

3.5.22 Electrical Installation, Control Terminals

To connect the cable to the terminal:

1. Strip insulation by about 0.34–0.39 in [9–10 mm]
2. Insert a screwdriver¹⁾ in the square hole.
3. Insert the cable in the adjacent circular hole.
4. Remove the screwdriver. The cable is now mounted in the terminal.

To remove the cable from the terminal:

1. Insert a screwdriver¹⁾ in the square hole.
2. Pull out the cable.

¹⁾ Max. 0.015 x 0.1 in. [0.4 x 2.5 mm]

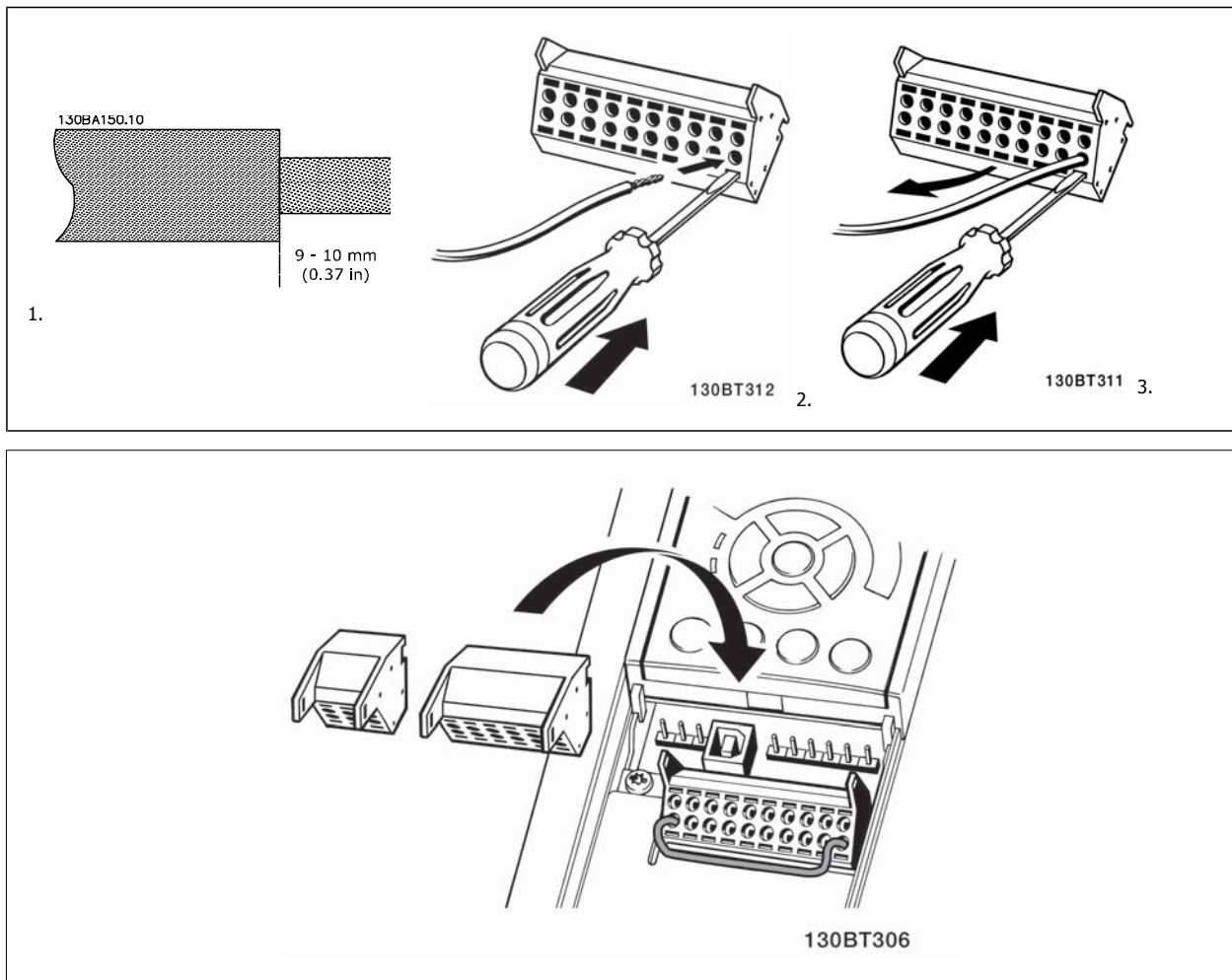

3.6 Connection Examples

3.6.1 Start/Stop

Terminal 18 = par. 5-10 *Terminal 18 Digital Input [8] Start*
 Terminal 27 = par. 5-12 *Terminal 27 Digital Input [0] No operation (Default coast inverse)*

Terminal 37 = Safe stop

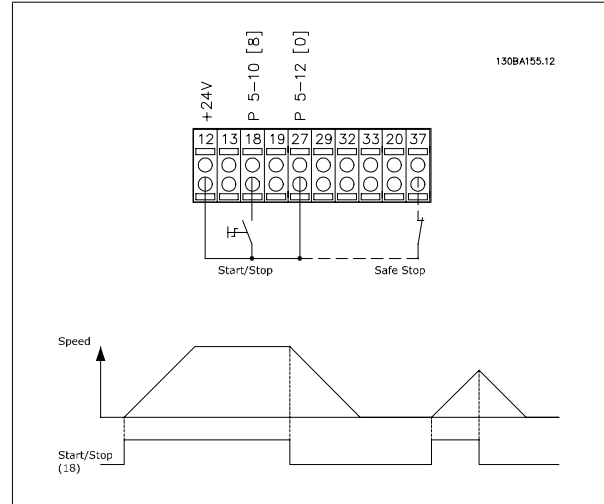

3

3.6.2 Pulse Start/Stop

Terminal 18 = par. 5-10 *Terminal 18 Digital Input [9] Latched start*
 Terminal 27 = par. 5-12 *Terminal 27 Digital Input [6] Stop inverse*

Terminal 37 = Safe stop

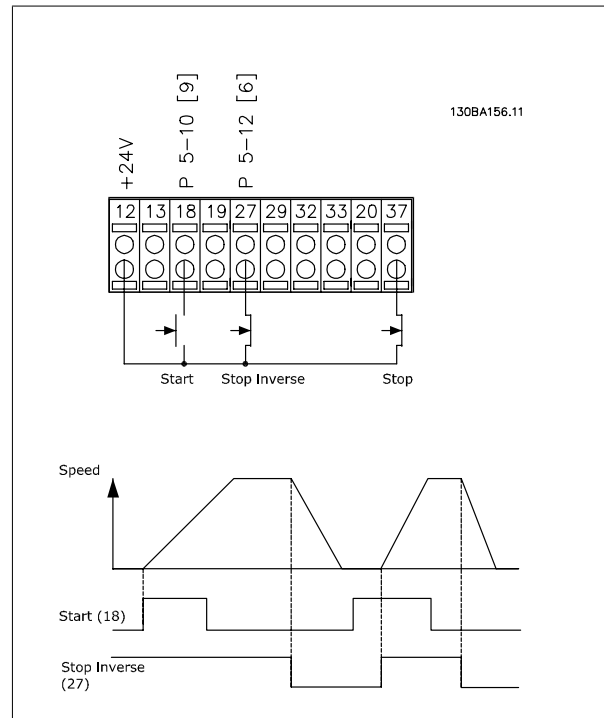

3

3.6.3 Speed Up/Down

Terminals 29/32 = Speed up/down:

Terminal 18 = par. 5-10 *Terminal 18 Digital Input* Start [9] (default)

Terminal 27 = par. 5-12 *Terminal 27 Digital Input* Freeze reference [19]

Terminal 29 = par. 5-13 *Terminal 29 Digital Input* Speed up [21]

Terminal 32 = par. 5-14 *Terminal 32 Digital Input* Slow [22]

Note: Terminal 29 only in FC x02 (x=series type).

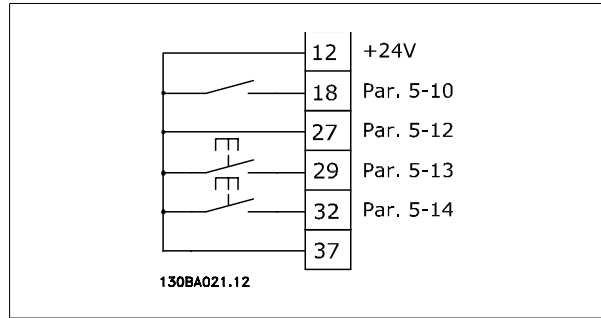

3.6.4 Potentiometer Reference

Voltage reference via a potentiometer:

Reference Source 1 = [1] *Analog input 53* (default)

Terminal 53, Low Voltage = 0 Volt

Terminal 53, High Voltage = 10 Volt

Terminal 53, Low Ref./Feedback = 0 RPM

Terminal 53, High Ref./Feedback = 1,500 RPM

Switch S201 = OFF (U)

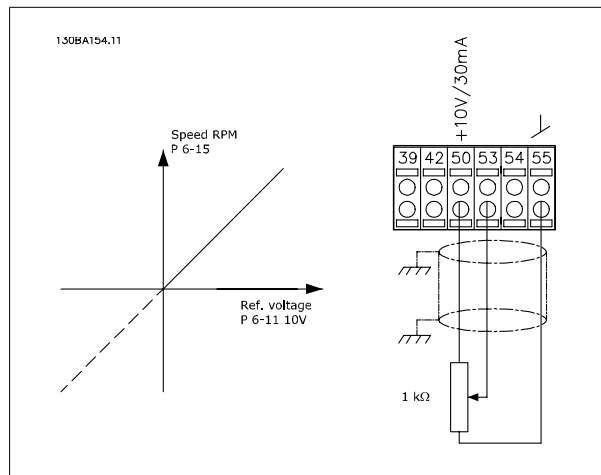

3.7.1 Electrical Installation, Control Cables

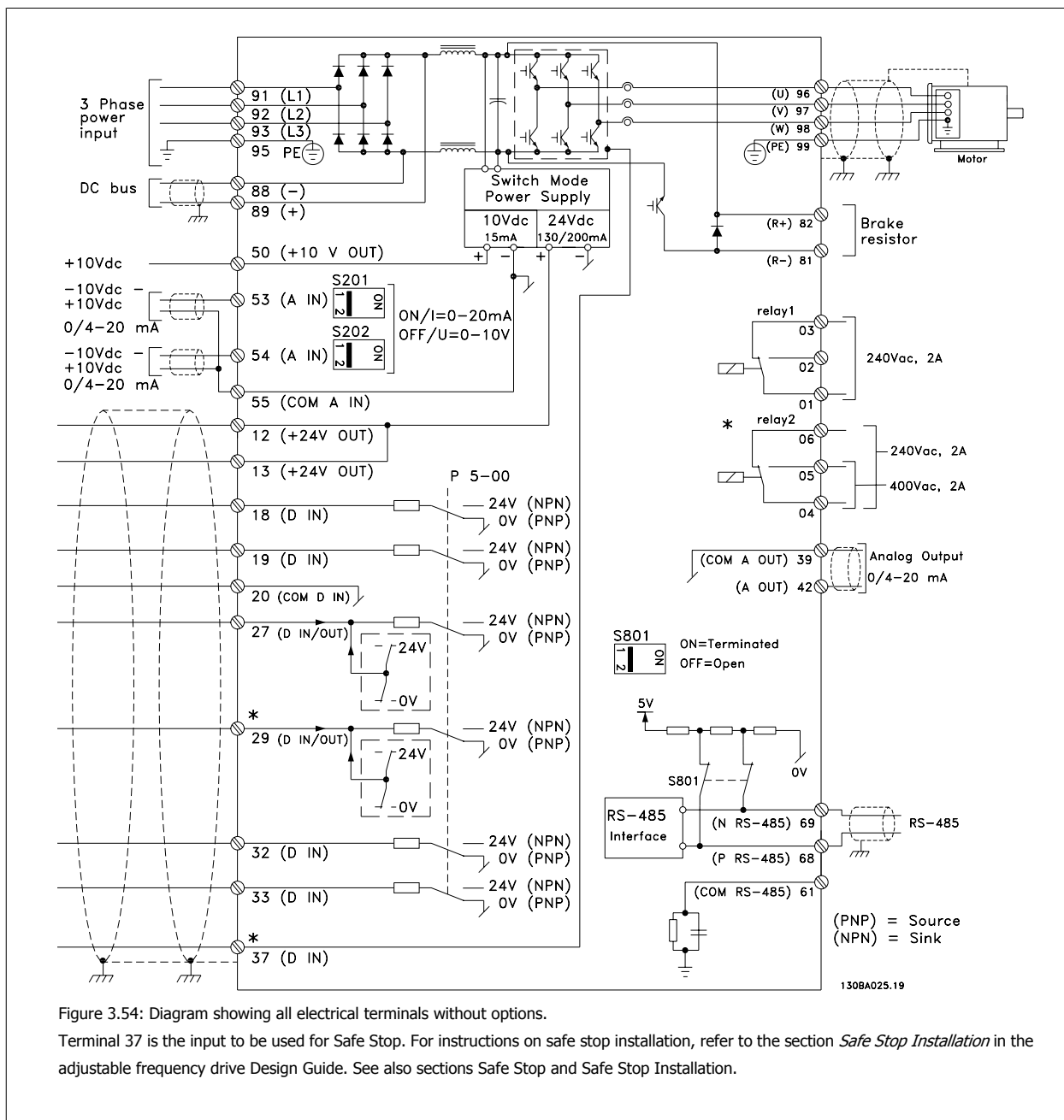

Figure 3.54: Diagram showing all electrical terminals without options.

Terminal 37 is the input to be used for Safe Stop. For instructions on safe stop installation, refer to the section *Safe Stop Installation* in the adjustable frequency drive Design Guide. See also sections Safe Stop and Safe Stop Installation.

In rare cases, very long control cables and analog signals may, depending on installation, result in 50/60 Hz ground loops due to noise from line power supply cables.

If this occurs, it may be necessary to break the shield or insert a 100 nF capacitor between shield and chassis.

The digital and analog inputs and outputs must be connected separately to the adjustable frequency drive common inputs (terminal 20, 55, 39) to avoid ground currents from both groups to affect other groups. For example, switching on the digital input may disturb the analog input signal.

Input polarity of control terminals

3

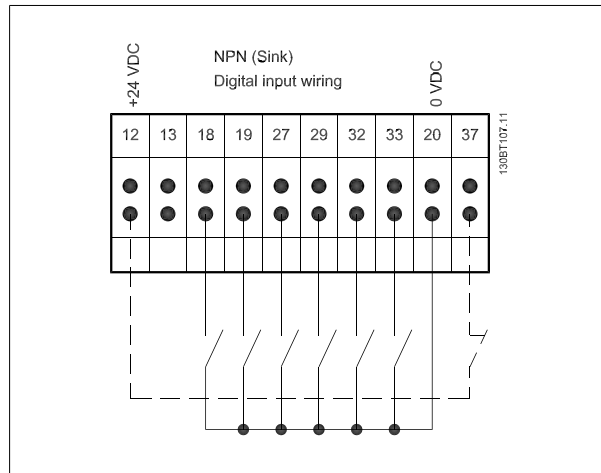
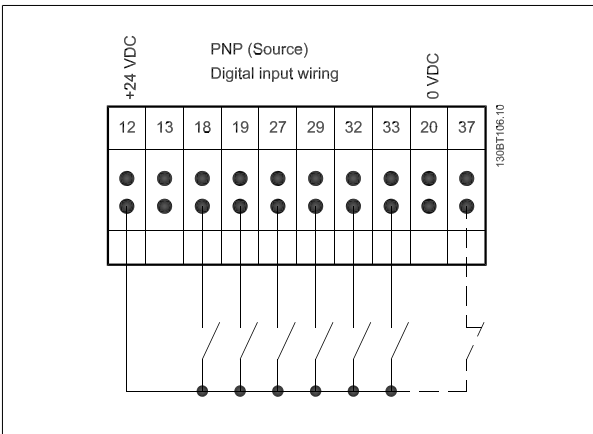

NOTE!

Control cables must be shielded/armored.

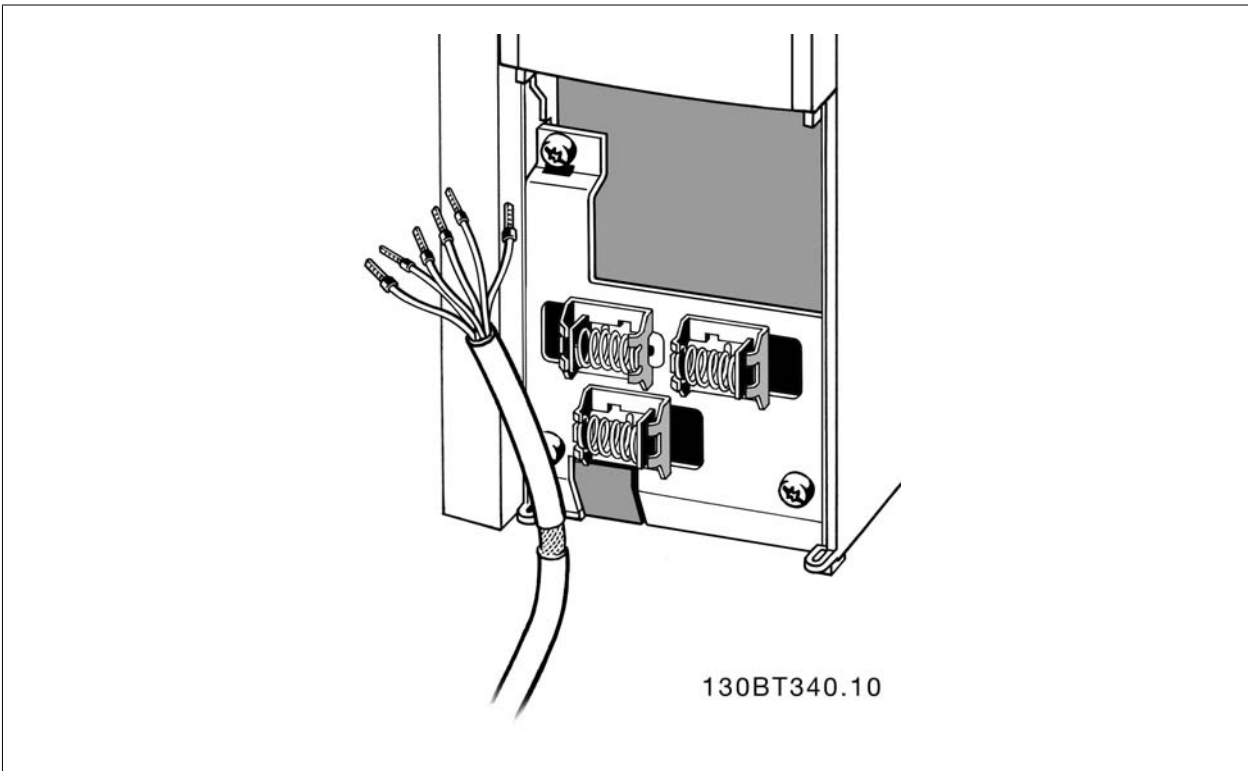

Connect the wires as described in the Instruction Manual for the adjustable frequency drive. Remember to connect the shields in a proper way to ensure optimum electrical immunity.

3.7.2 Switches S201, S202, and S801

Switches S201 (A53) and S202 (A54) are used to select a current (0-20 mA) or a voltage (-10 to 10 V) configuration for the analog input terminals 53 and 54, respectively.

Switch S801 (BUS TER.) can be used to enable termination on the RS-485 port (terminals 68 and 69).

See drawing *Diagram showing all electrical terminals* in section *Electrical Installation*.

Default setting:

S201 (A53) = OFF (voltage input)

S202 (A54) = OFF (voltage input)

S801 (Bus termination) = OFF



When changing the function of S201, S202 or S801, be careful not to force the switch over. It is recommended to remove the LCP fixture (cradle) when operating the switches. The switches must not be operated while the adjustable frequency drive is powered.

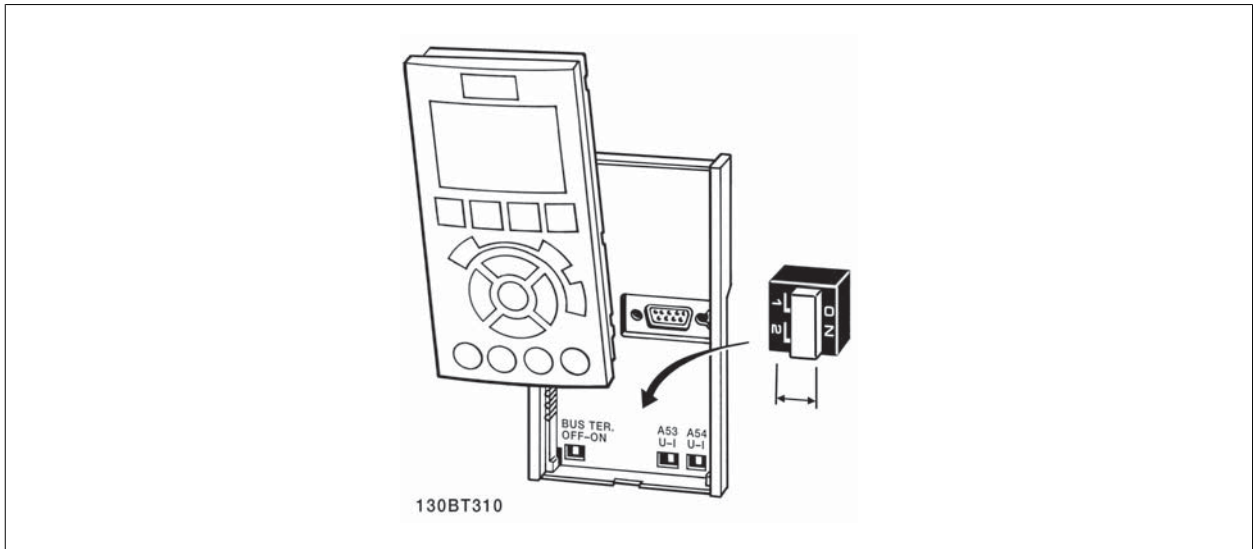

3.8 Final Set-Up and Test

To test the set-up and ensure that the adjustable frequency drive is running, follow these steps.

Step 1. Locate the motor nameplate

3



NOTE!

The motor is either star- (Y) or delta-connected (Δ). This information is located on the motor nameplate data.

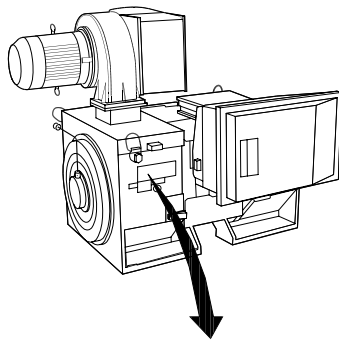

THREE PHASE INDUCTION MOTOR						
MOD MCV 315E	Nr.	135189 12 04		IL/IN 6.5		
kW 400	PRIMARY			SF 1.15		
HP 536	V 690	A 410.6	CONN Y	COS ϕ 0.85	40	
mm 1481	V	A	CONN	AMB 40	°C	
Hz 50	V	A	CONN	ALT 1000	m	
DESIGN N	SECONDARY			RISE 80	°C	
DUTY S1	V	A	CONN	ENCLOSURE IP23		
INSUL I	EFFICIENCY %	95.8%	100%	95.8%	75%	WEIGHT 1.83 ton
⚠ CAUTION						

130BA767.10

Step 2. Enter the motor nameplate data in this parameter list.

To access this list, first press the [QUICK MENU] key, then select "Q2 Quick Set-up".

- | | |
|----|--|
| 1. | Par. 1-20 <i>Motor Power [kW]</i>
Par. 1-21 <i>Motor Power [HP]</i> |
| 2. | Par. 1-22 <i>Motor Voltage</i> |
| 3. | Par. 1-23 <i>Motor Frequency</i> |
| 4. | Par. 1-24 <i>Motor Current</i> |
| 5. | Par. 1-25 <i>Motor Nominal Speed</i> |

Step 3. Activate the Automatic Motor Adaptation (AMA)

Performing an AMA will ensure optimum performance. The AMA measures the values from the motor model equivalent diagram.

1. Connect terminal 37 to terminal 12 (if terminal 37 is available).
2. Connect terminal 27 to terminal 12 or set par. 5-12 *Terminal 27 Digital Input* to 'No function' (par. 5-12 *Terminal 27 Digital Input* [0]).
3. Activate the AMA par. 1-29 *Automatic Motor Adaptation (AMA)*.
4. Choose between complete or reduced AMA. If a sine-wave filter is mounted, run only the reduced AMA, or remove the sine-wave filter during the AMA procedure.
5. Press the [OK] key. The display shows "Press [Hand on] to start".
6. Press the [Hand on] key. A progress bar indicates if the AMA is in progress.

Stop the AMA during operation

1. Press the [OFF] key - the adjustable frequency drive enters into alarm mode and the display shows that the AMA was terminated by the user.

Successful AMA

1. The display shows "Press [OK] to finish AMA".
2. Press the [OK] key to exit the AMA state.

Unsuccessful AMA

1. The adjustable frequency drive enters into alarm mode. A description of the alarm can be found in the *Warnings and Alarms* chapter.
2. "Report Value" in the [Alarm Log] shows the last measuring sequence carried out by the AMA before the adjustable frequency drive entered alarm mode. This number along with the description of the alarm will assist you in troubleshooting. If you contact Danfoss for service, make sure to mention the number and alarm description.



NOTE!

Unsuccessful AMA is often caused by incorrectly registered motor nameplate data or a too big difference between the motor power size and the adjustable frequency drive power size.

Step 4. Set speed limit and ramp time

Par. 3-02 *Minimum Reference*
Par. 3-03 *Maximum Reference*

Table 3.20: Set up the desired limits for speed and ramp time.

Par. 4-11 *Motor Speed Low Limit [RPM]* or par. 4-12 *Motor Speed Low Limit [Hz]*
Par. 4-13 *Motor Speed High Limit [RPM]* or par. 4-14 *Motor Speed High Limit [Hz]*

Par. 3-41 *Ramp 1 Ramp-up Time*
Par. 3-42 *Ramp 1 Ramp-down Time*

3.9 Additional Connections

3.9.1 Mechanical Brake Control

In hoisting/lowering applications, it is necessary to be able to control an electro-mechanical brake:

- Control the brake using any relay output or digital output (terminal 27 or 29).
- Keep the output closed (voltage-free) as long as the adjustable frequency drive is unable to 'support' the motor, such as when the load is too heavy, for example.
- Select *Mechanical brake control* [32] in par. 5-4* for applications with an electro-mechanical brake.
- The brake is released when the motor current exceeds the preset value in par. 2-20 *Release Brake Current*.
- The brake is engaged when the output frequency is less than the frequency set in par. 2-21 *Activate Brake Speed [RPM]* or par. 2-22 *Activate Brake Speed [Hz]*, and only if the adjustable frequency drive carries out a stop command.

If the adjustable frequency drive is in alarm mode or in an overvoltage situation, the mechanical brake immediately cuts in.

3.9.2 Parallel Connection of Motors

The adjustable frequency drive can control several parallel-connected motors. The total current consumption of the motors must not exceed the rated output current $I_{M,N}$ for the adjustable frequency drive.



NOTE!

Installation with cables connected in a common joint, as in the illustration below, is only recommended for short cable lengths.



NOTE!

When motors are connected in parallel, par. 1-29 *Automatic Motor Adaptation (AMA)* cannot be used.



NOTE!

The electronic thermal relay (ETR) of the adjustable frequency drive cannot be used as motor protection for the individual motor in systems with parallel-connected motors. Provide further motor protection with, for example, thermistors in each motor or individual thermal relays (circuit breakers are not suitable for protection).

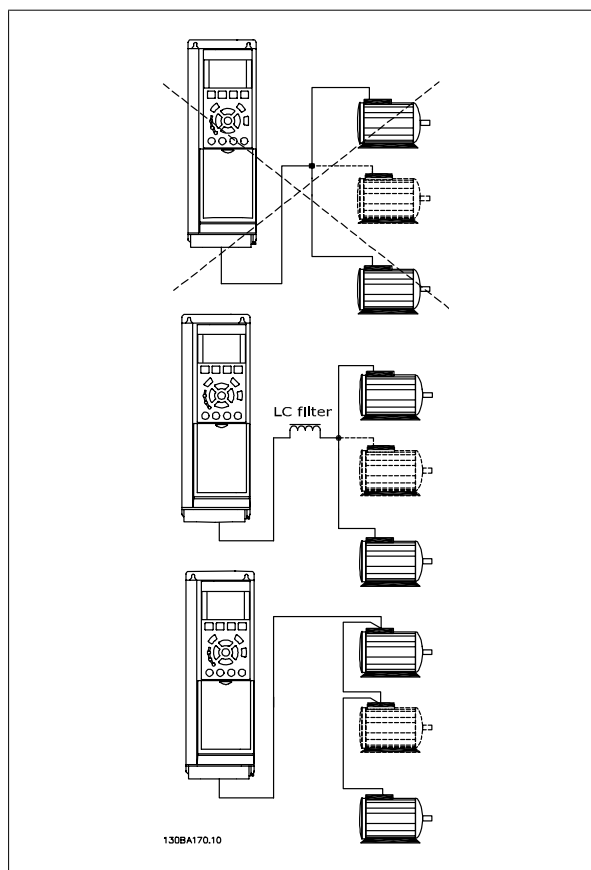

Problems may arise at start and at low RPM values if motor sizes are widely different because small motors' relatively high ohmic resistance in the stator calls for a higher voltage at start and at low RPM values.

3.9.3 Motor Thermal Protection

The electronic thermal relay in the adjustable frequency drive has received UL-approval for single motor protection, when par. 1-90 *Motor Thermal Protection* is set for *ETR Trip* and par. 1-24 *Motor Current* is set to the rated motor current (see motor nameplate).

For thermal motor protection, it is also possible to use the MCB 112 PTC thermistor card option. This card provides an ATEX certificate to protect motors in explosion hazard areas, Zone 1/21 and Zone 2/22. Please refer to the *Design Guide* for further information.

4 How to Program

4.1 The Graphical and Numerical LCP

The easiest programming of the adjustable frequency drive is performed by the Graphical LCP (102). It is necessary to consult the adjustable frequency drive Design Guide when using the Numeric Local Control Panel (LCP 101).

4.1.1 How to Program on the Graphical LCP

The following instructions are valid for the graphical LCP (LCP 102):

The control panel is divided into four functional groups:

1. Graphical display with Status lines.
2. Menu keys and LEDs - changing parameters and switching between display functions.
3. Navigation keys and LEDs (LEDs).
4. Operation keys and LEDs.

All data is displayed in a graphical LCP display, which can show up to five items of operating data while displaying [Status].

Display lines:

- a. **Status line:** Status messages displaying icons and graphic.
- b. **Line 1-2:** Operator data lines displaying data defined or chosen by the user. By pressing the [Status] key, up to one extra line can be added.
- c. **Status line:** Status messages displaying text.

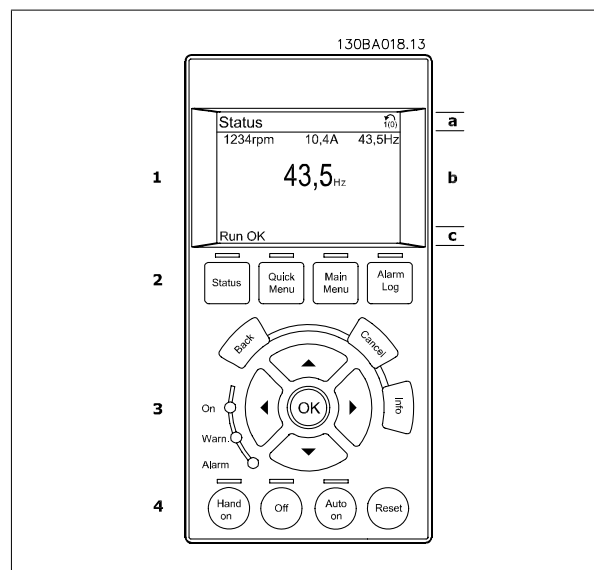

4.1.2 How to Program on the Numerical Local Control Panel

The following instructions are valid for the numerical LCP (LCP 101):

The control panel is divided into four functional groups:

1. Numerical display.
2. Menu keys and LEDs - changing parameters and switching between display functions.
3. Navigation keys and LEDs (LEDs).
4. Operation keys and LEDs.

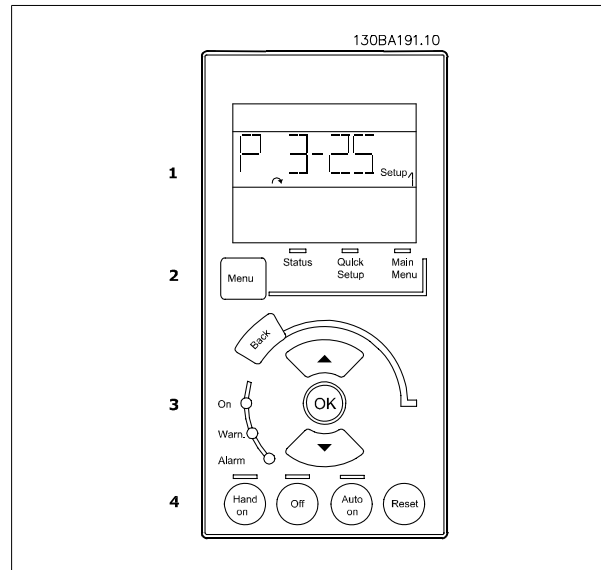

4.1.3 Initial Commissioning

The easiest way of carrying out the initial commissioning is by using the quick menu button and follow the quick set-up procedure using LCP 102 (read table from left to right). The example applies to open-loop applications:

Press			
		Q2 Quick Menu	
Par. 0-01 <i>Language</i>		Set language	
Par. 1-20 <i>Motor Power [kW]</i>		Set motor nameplate power	
Par. 1-22 <i>Motor Voltage</i>		Set nameplate voltage	
Par. 1-23 <i>Motor Frequency</i>		Set nameplate frequency	
Par. 1-24 <i>Motor Current</i>		Set nameplate current	
Par. 1-25 <i>Motor Nominal Speed</i>		Set nameplate speed in RPM	
Par. 5-12 <i>Terminal 27 Digital Input</i>		If terminal default is <i>Coast inverse</i> , it is possible to change this setting to <i>No function</i> . No connection to terminal 27 is then needed for running AMA	
Par. 1-29 <i>Automatic Motor Adaptation (AMA)</i>		Set desired AMA function. Enable complete AMA is recommended	
Par. 3-02 <i>Minimum Reference</i>		Set the minimum speed of the motor shaft	
Par. 3-03 <i>Maximum Reference</i>		Set the maximum speed of the motor shaft	
Par. 3-41 <i>Ramp 1 Ramp-up Time</i>		Set the ramping-up time with reference to synchronous motor speed, ns.	
Par. 3-42 <i>Ramp 1 Ramp-down Time</i>		Set the ramping-down time with reference to synchronous motor speed, ns.	
Par. 3-13 <i>Reference Site</i>		Set the site from where the reference must work	

4.2 Quick Set-up

0-01 Language

Option:

Function:

Defines the language to be used in the display. The adjustable frequency drive can be delivered with 4 different language packages. English and German are included in all packages. English cannot be erased or manipulated.

[0] *	English	Part of Language packages 1 - 4
[1]	Deutsch	Part of Language packages 1 - 4
[2]	Francais	Part of Language package 1
[3]	Dansk	Part of Language package 1
[4]	Spanish	Part of Language package 1
[5]	Italiano	Part of Language package 1
	Svenska	Part of Language package 1
[7]	Nederlands	Part of Language package 1
	Chinese	Part of Language package 2
	Suomi	Part of Language package 1
	English US	Part of Language package 4
	Greek	Part of Language package 4
	Bras.port	Part of Language package 4
	Slovenian	Part of Language package 3
	Korean	Part of Language package 2
	Japanese	Part of Language package 2
	Turkish	Part of Language package 4
	Trad.Chinese	Part of Language package 2
	Bulgarian	Part of Language package 3
	Srpski	Part of Language package 3
	Romanian	Part of Language package 3
	Magyar	Part of Language package 3
	Czech	Part of Language package 3
	Polski	Part of Language package 4
	Russian	Part of Language package 3
	Thai	Part of Language package 2
	Bahasa Indonesia	Part of Language package 2
[99]	Unknown	

1-20 Motor Power [kW]

Range: **Function:**

Application [Application dependant]
dependent*

1-22 Motor Voltage

Range: **Function:**

Application [Application dependant]
dependent*

1-23 Motor Frequency

Range: **Function:**

Application [20 - 1000 Hz]
dependent*

1-24 Motor Current

Range: **Function:**

Application [Application dependant]
dependent*



NOTE!

This parameter cannot be adjusted while the motor is running.

1-25 Motor Nominal Speed

Range: **Function:**

Application [100 - 60000 RPM]
dependent*

Enter the nominal motor speed value from the motor nameplate data. This data is used for calculating automatic motor compensations.



NOTE!

This parameter cannot be changed while the motor is running.

5-12 Terminal 27 Digital Input

Option:

Function:

Select the function from the available digital input range.

No operation	[0]
Reset	[1]
Coast inverse	[2]
Coast and reset inverse	[3]
Quick stop inverse	[4]
DC brake inverse	[5]
Stop inverse	[6]
Start	[8]
Latched start	[9]
Reversing	[10]
Start reversing	[11]
Enable start forward	[12]
Enable start reverse	[13]
Jog	[14]
Preset ref bit 0	[16]
Preset ref bit 1	[17]
Preset ref bit 2	[18]
Freeze reference	[19]
Freeze output	[20]
Speed up	[21]
Slow	[22]
Set-up select bit 0	[23]
Set-up select bit 1	[24]
Catch up	[28]
Slow-down	[29]
Pulse input	[32]
Ramp bit 0	[34]
Ramp bit 1	[35]
Line failure inverse	[36]
DigiPot Increase	[55]
DigiPot Decrease	[56]
DigiPot Clear	[57]
Reset Counter A	[62]
Reset Counter B	[65]

1-29 Automatic Motor Adaptation (AMA)

Option:

Function:

The AMA function optimizes dynamic motor performance by automatically optimizing the advanced motor parameters (par. 1-30 to par. 1-35) during motor standstill.

Activate the AMA function by pressing [Hand on] after selecting [1] or [2]. See also the section *Automatic Motor Adaptation*. After a normal sequence, the display will read: "Press [OK] to finish AMA". After pressing the [OK] key, the adjustable frequency drive is ready for operation.

This parameter cannot be adjusted while the motor is running.

[0] *	OFF	
[1]	Enable complete AMA	Performs AMA of the stator resistance R_s , the rotor resistance R_r , the stator leakage reactance X_1 , the rotor leakage reactance X_2 and the main reactance X_h . FC 301: The complete AMA does not include X_h measurement for FC 301. Instead, the X_h value is determined from the motor database. Par. 1-35 may be adjusted to obtain optimal start performance.
[2]	Enable reduced AMA	Performs a reduced AMA of the stator resistance R_s in the system only. Select this option if an LC filter is used between the drive and the motor.

Note:

- For the best adaptation of the adjustable frequency drive, run the AMA on a cold motor.
- AMA cannot be performed while the motor is running.
- AMA cannot be performed on permanent magnet motors.

NOTE!
It is important to set motor par. 1-2* correctly, since these form part of the AMA algorithm. An AMA must be performed to achieve optimum dynamic motor performance. It may take up to 10 min, depending on the power rating of the motor.

NOTE!
Avoid generating external torque during AMA.

NOTE!
If one of the settings in par. 1-2* is changed, par. 1-30 to par. 1-39, the advanced motor parameters, will return to default setting.

3-02 Minimum Reference

Range:

Function:

Application [Application dependant]
dependent*

3-03 Maximum Reference

Range:

Function:

Application [Application dependant]
dependent*

4.3 Parameter Lists

Changes during operation

"TRUE" means that the parameter can be changed while the adjustable frequency drive is in operation, and "FALSE" means that it must be stopped before a change can be made.

4-Set-up

'All set-up': the parameters can be set individually in each of the four set-ups, i.e., one single parameter can have four different data values.

'1 set-up': data value will be the same in all set-ups.

Conversion index

This number refers to a conversion figure used when writing or reading to and from the adjustable frequency drive.

Conv. index	100	67	6	5	4	3	2	1	0	-1	-2	-3	-4	-5	-6
Conv. factor	1	1/60	1000000	100000	10000	1000	100	10	1	0.1	0.01	0.001	0.0001	0.00001	0.000001

Data type	Description	Type
2	Integer 8	Int8
3	Integer 16	Int16
4	Integer 32	Int32
5	Unsigned 8	UInt8
6	Unsigned 16	UInt16
7	Unsigned 32	UInt32
9	Visible String	VisStr
33	Normalized value 2 bytes	N2
35	Bit sequence of 16 Boolean variables	V2
54	Time difference w/o date	TimD

See the adjustable frequency drive *Design Guide* for further information about data types 33, 35 and 54.

Parameters for the adjustable frequency drive are grouped into various parameter groups for easy selection of the correct parameters for optimized operation of the adjustable frequency drive.

0-** Operation and display parameters for basic adjustable frequency drive settings

1-** Load and motor parameters, includes all load and motor related parameters

2-** Brake parameters

3-** References and ramping parameters, includes DigiPot function

4-** Limits/warnings, setting of limits and warning parameters

5-** Digital inputs and outputs, includes relay controls

6-** Analog inputs and outputs

7-** Controls, setting parameters for speed and process controls

8-** Communication and option parameters, setting of Adjustable Frequency Drive RS485 and Adjustable Frequency Drive USB port parameters.

9-** Profibus parameters

10-** DeviceNet and CAN serial communication bus parameters

13-** Smart Logic Control parameters

14-** Special function parameters

15-** Drive information parameters

16-** Readout parameters

17-** Encoder Option parameters

32-** MCO 305 Basic parameters

33-** MCO 305 Advanced parameters

34-** MCO Data Readout parameters

4.3.1 0-** Operation/Display

Par. No. #	Parameter description	Default value	4 set-up	FC 302 only	Change during operation	Conversion index	Type
0-0* Basic Settings							
0-01	Language	[0] English	1 set-up		TRUE	-	Uint8
0-02	Motor Speed Unit	[0] RPM	2 set-ups		FALSE	-	Uint8
0-03	Regional Settings	[0] International	2 set-ups		FALSE	-	Uint8
0-04	Operating State at Power-up (Hand)	[1] Forced stop, ref=old	All set-ups		TRUE	-	Uint8
0-1* Set-up Operations							
0-10	Active Set-up	[1] Set-up 1	1 set-up		TRUE	-	Uint8
0-11	Edit Set-up	[1] Set-up 1	All set-ups		TRUE	-	Uint8
0-12	This Set-up Linked to	[0] Not linked	All set-ups		FALSE	-	Uint8
0-13	Readout: Linked Set-ups	0 N/A	All set-ups		FALSE	0	Uint16
0-14	Readout: Edit Set-ups / Channel	0 N/A	All set-ups		TRUE	0	Int32
0-2* LCP Display							
0-20	Display Line 1.1 Small	1617	All set-ups		TRUE	-	Uint16
0-21	Display Line 1.2 Small	1614	All set-ups		TRUE	-	Uint16
0-22	Display Line 1.3 Small	1610	All set-ups		TRUE	-	Uint16
0-23	Display Line 2 Large	1613	All set-ups		TRUE	-	Uint16
0-24	Display Line 3 Large	1602	All set-ups		TRUE	-	Uint16
0-25	My Personal Menu	ExpressionLimit	1 set-up		TRUE	0	Uint16
0-3* LCP Cust. Readout							
0-30	Unit for User-defined Readout	[0] None	All set-ups		TRUE	-	Uint8
0-31	Min Value of User-defined Readout	0.00 CustomReadoutUnit	All set-ups		TRUE	-2	Int32
0-32	Max Value of User-defined Readout	100.00 CustomReadoutUnit	All set-ups		TRUE	-2	Int32
0-4* LCP Keypad							
0-40	[Hand on] Key on LCP	null	All set-ups		TRUE	-	Uint8
0-41	[Off] Key on LCP	null	All set-ups		TRUE	-	Uint8
0-42	[Auto on] Key on LCP	null	All set-ups		TRUE	-	Uint8
0-43	[Reset] Key on LCP	null	All set-ups		TRUE	-	Uint8
0-5* Copy/Save							
0-50	LCP Copy	[0] No copy	All set-ups		FALSE	-	Uint8
0-51	Set-up Copy	[0] No copy	All set-ups		FALSE	-	Uint8
0-6* Password							
0-60	Main Menu Password	100 N/A	1 set-up		TRUE	0	Int16
0-61	Access to Main Menu w/o Password	[0] Full access	1 set-up		TRUE	-	Uint8
0-65	Quick Menu Password	200 N/A	1 set-up		TRUE	0	Int16
0-66	Access to Quick Menu w/o Password	[0] Full access	1 set-up		TRUE	-	Uint8
0-67	Bus Password Access	0 N/A	All set-ups		TRUE	0	Uint16

4.3.2 1-*** Load/Motor

Par. No. #	Parameter description	Default value	4-set-up	FC 302 only	Change during operation	Conversion index	Type
1-0* General Settings							
1-00	Configuration Mode	null	All set-ups		TRUE	-	Uint8
1-01	Motor Control Principle	null	All set-ups		FALSE	-	Uint8
1-02	Flux Motor Feedback Source	[1] 24V encoder	All set-ups	x	FALSE	-	Uint8
1-03	Torque Characteristics	[0] Constant torque	All set-ups		TRUE	-	Uint8
1-04	Overload Mode	[0] High torque	All set-ups		FALSE	-	Uint8
1-05	Local Mode Configuration	[2] As mode par 1-00	All set-ups		TRUE	-	Uint8
1-1* Motor Selection							
1-10	Motor Construction	[0] Asynchron	All set-ups		FALSE	-	Uint8
1-2* Motor Data							
1-20	Motor Power [kW]	ExpressionLimit	All set-ups		FALSE	1	Uint32
1-21	Motor Power [HP]	ExpressionLimit	All set-ups		FALSE	-2	Uint32
1-22	Motor Voltage	ExpressionLimit	All set-ups		FALSE	0	Uint16
1-23	Motor Frequency	ExpressionLimit	All set-ups		FALSE	0	Uint16
1-24	Motor Current	ExpressionLimit	All set-ups		FALSE	-2	Uint32
1-25	Motor Nominal Speed	ExpressionLimit	All set-ups		FALSE	67	Uint16
1-26	Motor Cont. Rated Torque	ExpressionLimit	All set-ups		FALSE	-1	Uint32
1-29	Automatic Motor Adaptation (AMA)	[0] Off	All set-ups		FALSE	-	Uint8
1-3* Addl. Motor Data							
1-30	Stator Resistance (Rs)	ExpressionLimit	All set-ups		FALSE	-4	Uint32
1-31	Rotor Resistance (Rr)	ExpressionLimit	All set-ups		FALSE	-4	Uint32
1-33	Stator Leakage Reactance (X1)	ExpressionLimit	All set-ups		FALSE	-4	Uint32
1-34	Rotor Leakage Reactance (X2)	ExpressionLimit	All set-ups		FALSE	-4	Uint32
1-35	Main Reactance (Xh)	ExpressionLimit	All set-ups		FALSE	-4	Uint32
1-36	Iron Loss Resistance (Rfe)	ExpressionLimit	All set-ups		FALSE	-3	Uint32
1-37	d-axis Inductance (Ld)	ExpressionLimit	All set-ups	x	FALSE	-4	Uint32
1-39	Motor Poles	ExpressionLimit	All set-ups		FALSE	0	Uint8
1-40	Back EMF at 1000 RPM	ExpressionLimit	All set-ups	x	FALSE	0	Uint16
1-41	Motor Angle Offset	0 N/A	All set-ups		FALSE	0	Int16
1-5* Load-Indep. Setting							
1-50	Motor Magnetization at Zero Speed	100 %	All set-ups		TRUE	0	Uint16
1-51	Min Speed Normal Magnetizing [RPM]	ExpressionLimit	All set-ups		TRUE	67	Uint16
1-52	Min Speed Normal Magnetizing [Hz]	ExpressionLimit	All set-ups		TRUE	-1	Uint16
1-53	Model Shift Frequency	ExpressionLimit	All set-ups	x	FALSE	-1	Uint16
1-55	U/f Characteristic - U	ExpressionLimit	All set-ups		TRUE	-1	Uint16
1-56	U/f Characteristic - F	ExpressionLimit	All set-ups		TRUE	-1	Uint16
1-6* Load-Depend. Settng.							
1-60	Low Speed Load Compensation	100 %	All set-ups		TRUE	0	Int16
1-61	High Speed Load Compensation	100 %	All set-ups		TRUE	0	Int16
1-62	Slip Compensation	ExpressionLimit	All set-ups		TRUE	0	Int16
1-63	Slip Compensation Time Constant	ExpressionLimit	All set-ups		TRUE	-2	Uint16
1-64	Resonance Dampening	100 %	All set-ups		TRUE	0	Uint16
1-65	Resonance Dampening Time Constant	5 ms	All set-ups		TRUE	-3	Uint8
1-66	Min. Current at Low Speed	100 %	All set-ups	x	TRUE	0	Uint8
1-67	Load Type	[0] Passive load	All set-ups	x	TRUE	-	Uint8
1-68	Minimum Inertia	ExpressionLimit	All set-ups	x	FALSE	-4	Uint32
1-69	Maximum Inertia	ExpressionLimit	All set-ups	x	FALSE	-4	Uint32
1-7* Start Adjustments							
1-71	Start Delay	0.0 s	All set-ups		TRUE	-1	Uint8
1-72	Start Function	[2] Coast/delay time	All set-ups		TRUE	-	Uint8
1-73	Flying Start	[0] Disabled	All set-ups		FALSE	-	Uint8
1-74	Start Speed [RPM]	ExpressionLimit	All set-ups		TRUE	67	Uint16
1-75	Start Speed [Hz]	ExpressionLimit	All set-ups		TRUE	-1	Uint16
1-76	Start Current	0.00 A	All set-ups		TRUE	-2	Uint32
1-8* Stop Adjustments							
1-80	Function at Stop	[0] Coast	All set-ups		TRUE	-	Uint8
1-81	Min Speed for Function at Stop [RPM]	ExpressionLimit	All set-ups		TRUE	67	Uint16
1-82	Min Speed for Function at Stop [Hz]	ExpressionLimit	All set-ups		TRUE	-1	Uint16
1-83	Precise Stop Function	[0] Precise ramp stop	All set-ups		FALSE	-	Uint8
1-84	Precise Stop Counter Value	100000 N/A	All set-ups		TRUE	0	Uint32
1-85	Precise Stop Speed Compensation Delay	10 ms	All set-ups		TRUE	-3	Uint8
1-9* Motor Temperature							
1-90	Motor Thermal Protection	[0] No protection	All set-ups		TRUE	-	Uint8
1-91	Motor External Fan	[0] No	All set-ups		TRUE	-	Uint16
1-93	Thermistor Resource	[0] None	All set-ups		TRUE	-	Uint8
1-95	KTY Sensor Type	[0] KTY Sensor 1	All set-ups	x	TRUE	-	Uint8
1-96	KTY Thermistor Resource	[0] None	All set-ups	x	TRUE	-	Uint8
1-97	KTY Threshold level	80 °C	1 set-up	x	TRUE	100	Int16

4.3.3 2-** Brakes

Par. No. #	Parameter description	Default value	4-set-up	FC 302 only	Change during operation	Conversion index	Type
2-0* DC Brake							
2-00	DC Hold Current	50 %	All set-ups		TRUE	0	Uint8
2-01	DC Brake Current	50 %	All set-ups		TRUE	0	Uint16
2-02	DC Braking Time	10.0 s	All set-ups		TRUE	-1	Uint16
2-03	DC Brake Cut-in Speed [RPM]	ExpressionLimit	All set-ups		TRUE	67	Uint16
2-04	DC Brake Cut-in Speed [Hz]	ExpressionLimit	All set-ups		TRUE	-1	Uint16
2-05	Maximum Reference	MaxReference (P303)	All set-ups		TRUE	-3	Int32
2-1* Brake Energy Funct.							
2-10	Brake Function	null	All set-ups		TRUE	-	Uint8
2-11	Brake Resistor (ohm)	ExpressionLimit	All set-ups		TRUE	0	Uint16
2-12	Brake Power Limit (kW)	ExpressionLimit	All set-ups		TRUE	0	Uint32
2-13	Brake Power Monitoring	[0] Off	All set-ups		TRUE	-	Uint8
2-15	Brake Check	[0] Off	All set-ups		TRUE	-	Uint8
2-16	AC Brake Max. Current	100.0 %	All set-ups		TRUE	-1	Uint32
2-17	Over-voltage Control	[0] Disabled	All set-ups		TRUE	-	Uint8
2-18	Brake Check Condition	[0] At Power Up	All set-ups		TRUE	-	Uint8
2-2* Mechanical Brake							
2-20	Release Brake Current	ImaxVLT (P1637)	All set-ups		TRUE	-2	Uint32
2-21	Activate Brake Speed [RPM]	ExpressionLimit	All set-ups		TRUE	67	Uint16
2-22	Activate Brake Speed [Hz]	ExpressionLimit	All set-ups		TRUE	-1	Uint16
2-23	Activate Brake Delay	0.0 s	All set-ups		TRUE	-1	Uint8
2-24	Stop Delay	0.0 s	All set-ups		TRUE	-1	Uint8
2-25	Brake Release Time	0.20 s	All set-ups		TRUE	-2	Uint16
2-26	Torque Ref	0.00 %	All set-ups		TRUE	-2	Int16
2-27	Torque Ramp Time	0.2 s	All set-ups		TRUE	-1	Uint8
2-28	Gain Boost Factor	1.00 N/A	All set-ups		TRUE	-2	Uint16

4.3.4 3-** Reference / Ramps

Par. No. #	Parameter description	Default value	4-set-up	FC 302 only	Change during operation	Conversion index	Type
3-0* Reference Limits							
3-00	Reference Range	null	All set-ups		TRUE	-	Uint8
3-01	Reference/Feedback Unit	null	All set-ups		TRUE	-	Uint8
3-02	Minimum Reference	ExpressionLimit	All set-ups		TRUE	-3	Int32
3-03	Maximum Reference	ExpressionLimit	All set-ups		TRUE	-3	Int32
3-04	Reference Function	[0] Sum	All set-ups		TRUE	-	Uint8
3-1* References							
3-10	Preset Reference	0.00 %	All set-ups		TRUE	-2	Int16
3-11	Jog Speed [Hz]	ExpressionLimit	All set-ups		TRUE	-1	Uint16
3-12	Catch up/slow-down Value	0.00 %	All set-ups		TRUE	-2	Int16
3-13	Reference Site	[0] Linked to Hand / Auto	All set-ups		TRUE	-	Uint8
3-14	Preset Relative Reference	0.00 %	All set-ups		TRUE	-2	Int32
3-15	Reference Resource 1	null	All set-ups		TRUE	-	Uint8
3-16	Reference Resource 2	null	All set-ups		TRUE	-	Uint8
3-17	Reference Resource 3	null	All set-ups		TRUE	-	Uint8
3-18	Relative Scaling Reference Resource	[0] No function	All set-ups		TRUE	-	Uint8
3-19	Jog Speed [RPM]	ExpressionLimit	All set-ups		TRUE	67	Uint16
3-4* Ramp 1							
3-40	Ramp 1 Type	[0] Linear	All set-ups		TRUE	-	Uint8
3-41	Ramp 1 Ramp-up Time	ExpressionLimit	All set-ups		TRUE	-2	Uint32
3-42	Ramp 1 Ramp-down Time	ExpressionLimit	All set-ups		TRUE	-2	Uint32
3-45	Ramp 1 S-ramp Ratio at Accel. Start	50 %	All set-ups		TRUE	0	Uint8
3-46	Ramp 1 S-ramp Ratio at Accel. End	50 %	All set-ups		TRUE	0	Uint8
3-47	Ramp 1 S-ramp Ratio at Decel. Start	50 %	All set-ups		TRUE	0	Uint8
3-48	Ramp 1 S-ramp Ratio at Decel. End	50 %	All set-ups		TRUE	0	Uint8
3-5* Ramp 2							
3-50	Ramp 2 Type	[0] Linear	All set-ups		TRUE	-	Uint8
3-51	Ramp 2 Ramp-up Time	ExpressionLimit	All set-ups		TRUE	-2	Uint32
3-52	Ramp 2 Ramp-down Time	ExpressionLimit	All set-ups		TRUE	-2	Uint32
3-55	Ramp 2 S-ramp Ratio at Accel. Start	50 %	All set-ups		TRUE	0	Uint8
3-56	Ramp 2 S-ramp Ratio at Accel. End	50 %	All set-ups		TRUE	0	Uint8
3-57	Ramp 2 S-ramp Ratio at Decel. Start	50 %	All set-ups		TRUE	0	Uint8
3-58	Ramp 2 S-ramp Ratio at Decel. End	50 %	All set-ups		TRUE	0	Uint8
3-6* Ramp 3							
3-60	Ramp 3 Type	[0] Linear	All set-ups		TRUE	-	Uint8
3-61	Ramp 3 Ramp-up Time	ExpressionLimit	All set-ups		TRUE	-2	Uint32
3-62	Ramp 3 Ramp-down Time	ExpressionLimit	All set-ups		TRUE	-2	Uint32
3-65	Ramp 3 S-ramp Ratio at Accel. Start	50 %	All set-ups		TRUE	0	Uint8
3-66	Ramp 3 S-ramp Ratio at Accel. End	50 %	All set-ups		TRUE	0	Uint8
3-67	Ramp 3 S-ramp Ratio at Decel. Start	50 %	All set-ups		TRUE	0	Uint8
3-68	Ramp 3 S-ramp Ratio at Decel. End	50 %	All set-ups		TRUE	0	Uint8
3-7* Ramp 4							
3-70	Ramp 4 Type	[0] Linear	All set-ups		TRUE	-	Uint8
3-71	Ramp 4 Ramp-up Time	ExpressionLimit	All set-ups		TRUE	-2	Uint32
3-72	Ramp 4 Ramp-down Time	ExpressionLimit	All set-ups		TRUE	-2	Uint32
3-75	Ramp 4 S-ramp Ratio at Accel. Start	50 %	All set-ups		TRUE	0	Uint8
3-76	Ramp 4 S-ramp Ratio at Accel. End	50 %	All set-ups		TRUE	0	Uint8
3-77	Ramp 4 S-ramp Ratio at Decel. Start	50 %	All set-ups		TRUE	0	Uint8
3-78	Ramp 4 S-ramp Ratio at Decel. End	50 %	All set-ups		TRUE	0	Uint8
3-8* Other Ramps							
3-80	Jog Ramp Time	ExpressionLimit	All set-ups		TRUE	-2	Uint32
3-81	Quick Stop Ramp Time	ExpressionLimit	2 set-ups		TRUE	-2	Uint32
3-82	Quick Stop Ramp Type	[0] Linear	All set-ups		TRUE	-	Uint8
3-83	Quick Stop S-ramp Ratio at Decel. Start	50 %	All set-ups		TRUE	0	Uint8
3-84	Quick Stop S-ramp Ratio at Decel. End	50 %	All set-ups		TRUE	0	Uint8
3-9* Digital Pot. meter							
3-90	Step Size	0.10 %	All set-ups		TRUE	-2	Uint16
3-91	Ramp Time	1.00 s	All set-ups		TRUE	-2	Uint32
3-92	Power Restore	[0] Off	All set-ups		TRUE	-	Uint8
3-93	Maximum Limit	100 %	All set-ups		TRUE	0	Int16
3-94	Minimum Limit	-100 %	All set-ups		TRUE	0	Int16
3-95	Ramp Delay	ExpressionLimit	All set-ups		TRUE	-3	TimD

4.3.5 4-** Limits / Warnings

Par. No. #	Parameter description	Default value	4-set-up	FC 302 only	Change during operation	Conversion index	Type
4-1* Motor Limits							
4-10	Motor Speed Direction	null	All set-ups		FALSE	-	Uint8
4-11	Motor Speed Low Limit [RPM]	ExpressionLimit	All set-ups		TRUE	67	Uint16
4-12	Motor Speed Low Limit [Hz]	ExpressionLimit	All set-ups		TRUE	-1	Uint16
4-13	Motor Speed High Limit [RPM]	ExpressionLimit	All set-ups		TRUE	67	Uint16
4-14	Motor Speed High Limit [Hz]	ExpressionLimit	All set-ups		TRUE	-1	Uint16
4-16	Torque Limit Motor Mode	ExpressionLimit	All set-ups		TRUE	-1	Uint16
4-17	Torque Limit Generator Mode	100.0 %	All set-ups		TRUE	-1	Uint16
4-18	Current Limit	ExpressionLimit	All set-ups		TRUE	-1	Uint32
4-19	Max Output Frequency	132.0 Hz	All set-ups		FALSE	-1	Uint16
4-2* Limit Factors							
4-20	Torque Limit Factor Source	[0] No function	All set-ups		TRUE	-	Uint8
4-21	Speed Limit Factor Source	[0] No function	All set-ups		TRUE	-	Uint8
4-3* Motor Fb Monitor							
4-30	Motor Feedback Loss Function	[2] Trip	All set-ups		TRUE	-	Uint8
4-31	Motor Feedback Speed Error	300 RPM	All set-ups		TRUE	67	Uint16
4-32	Motor Feedback Loss Timeout	0.05 s	All set-ups		TRUE	-2	Uint16
4-34	Tracking Error Function	[0] Disable	All set-ups		TRUE	-	Uint8
4-35	Tracking Error	10 RPM	All set-ups		TRUE	67	Uint16
4-36	Tracking Error Timeout	1.00 s	All set-ups		TRUE	-2	Uint16
4-37	Tracking Error Ramping	100 RPM	All set-ups		TRUE	67	Uint16
4-38	Tracking Error Ramping Timeout	1.00 s	All set-ups		TRUE	-2	Uint16
4-39	Tracking Error After Ramping Timeout	5.00 s	All set-ups		TRUE	-2	Uint16
4-5* Adj. Warnings							
4-50	Warning Current Low	0.00 A	All set-ups		TRUE	-2	Uint32
4-51	Warning Current High	ImaxVLT (P1637)	All set-ups		TRUE	-2	Uint32
4-52	Warning Speed Low	0 RPM	All set-ups		TRUE	67	Uint16
4-53	Warning Speed High	outputSpeedHighLimit (P413)	All set-ups		TRUE	67	Uint16
4-54	Warning Reference Low	-999999.999 N/A	All set-ups		TRUE	-3	Int32
4-55	Warning Reference High	999999.999 N/A	All set-ups		TRUE	-3	Int32
4-56	Warning Feedback Low	-999999.999 Reference-FeedbackUnit	All set-ups		TRUE	-3	Int32
4-57	Warning Feedback High	999999.999 ReferenceFeed-backUnit	All set-ups		TRUE	-3	Int32
4-58	Missing Motor Phase Function	null	All set-ups		TRUE	-	Uint8
4-6* Speed Bypass							
4-60	Bypass Speed From [RPM]	ExpressionLimit	All set-ups		TRUE	67	Uint16
4-61	Bypass Speed From [Hz]	ExpressionLimit	All set-ups		TRUE	-1	Uint16
4-62	Bypass Speed to [RPM]	ExpressionLimit	All set-ups		TRUE	67	Uint16
4-63	Bypass Speed To [Hz]	ExpressionLimit	All set-ups		TRUE	-1	Uint16

4.3.6 5-** Digital In/Out

Par. No. #	Parameter description	Default value	4-set-up	FC 302 only	Change during operation	Conversion index	Type
5-0* Digital I/O mode							
5-00	Digital I/O Mode	[0] PNP	All set-ups		FALSE	-	Uint8
5-01	Terminal 27 Mode	[0] Input	All set-ups		TRUE	-	Uint8
5-02	Terminal 29 Mode	[0] Input	All set-ups	x	TRUE	-	Uint8
5-1* Digital Inputs							
5-10	Terminal 18 Digital Input	null	All set-ups		TRUE	-	Uint8
5-11	Terminal 19 Digital Input	null	All set-ups		TRUE	-	Uint8
5-12	Terminal 27 Digital Input	null	All set-ups		TRUE	-	Uint8
5-13	Terminal 29 Digital Input	null	All set-ups	x	TRUE	-	Uint8
5-14	Terminal 32 Digital Input	null	All set-ups		TRUE	-	Uint8
5-15	Terminal 33 Digital Input	null	All set-ups		TRUE	-	Uint8
5-16	Terminal X30/2 Digital Input	null	All set-ups		TRUE	-	Uint8
5-17	Terminal X30/3 Digital Input	null	All set-ups		TRUE	-	Uint8
5-18	Terminal X30/4 Digital Input	null	All set-ups		TRUE	-	Uint8
5-19	Terminal 37 Safe Stop	[1] Safe Stop Alarm	1 set-up		TRUE	-	Uint8
5-20	Terminal X46/1 Digital Input	[0] No operation	All set-ups		TRUE	-	Uint8
5-21	Terminal X46/3 Digital Input	[0] No operation	All set-ups		TRUE	-	Uint8
5-22	Terminal X46/5 Digital Input	[0] No operation	All set-ups		TRUE	-	Uint8
5-23	Terminal X46/7 Digital Input	[0] No operation	All set-ups		TRUE	-	Uint8
5-24	Terminal X46/9 Digital Input	[0] No operation	All set-ups		TRUE	-	Uint8
5-25	Terminal X46/11 Digital Input	[0] No operation	All set-ups		TRUE	-	Uint8
5-26	Terminal X46/13 Digital Input	[0] No operation	All set-ups		TRUE	-	Uint8
5-3* Digital Outputs							
5-30	Terminal 27 Digital Output	null	All set-ups		TRUE	-	Uint8
5-31	Terminal 29 digital Output	null	All set-ups	x	TRUE	-	Uint8
5-32	Term X30/6 Digi Out (MCB 101)	null	All set-ups		TRUE	-	Uint8
5-33	Term X30/7 Digi Out (MCB 101)	null	All set-ups		TRUE	-	Uint8
5-4* Relays							
5-40	Function Relay	null	All set-ups		TRUE	-	Uint8
5-41	On Delay, Relay	0.01 s	All set-ups		TRUE	-2	Uint16
5-42	Off Delay, Relay	0.01 s	All set-ups		TRUE	-2	Uint16
5-5* Pulse Input							
5-50	Term. 29 Low Frequency	100 Hz	All set-ups	x	TRUE	0	Uint32
5-51	Term. 29 High Frequency	100 Hz	All set-ups	x	TRUE	0	Uint32
5-52	Term. 29 Low Ref./Feedb. Value	0.000 ReferenceFeedbackUnit	All set-ups	x	TRUE	-3	Int32
5-53	Term. 29 High Ref./Feedb. Value	ExpressionLimit	All set-ups	x	TRUE	-3	Int32
5-54	Pulse Filter Time Constant #29	100 ms	All set-ups	x	FALSE	-3	Uint16
5-55	Term. 33 Low Frequency	100 Hz	All set-ups		TRUE	0	Uint32
5-56	Term. 33 High Frequency	100 Hz	All set-ups		TRUE	0	Uint32
5-57	Term. 33 Low Ref./Feedb. Value	0.000 ReferenceFeedbackUnit	All set-ups		TRUE	-3	Int32
5-58	Term. 33 High Ref./Feedb. Value	ExpressionLimit	All set-ups		TRUE	-3	Int32
5-59	Pulse Filter Time Constant #33	100 ms	All set-ups		FALSE	-3	Uint16
5-6* Pulse Output							
5-60	Terminal 27 Pulse Output Variable	null	All set-ups		TRUE	-	Uint8
5-62	Pulse Output Max Freq #27	ExpressionLimit	All set-ups		TRUE	0	Uint32
5-63	Terminal 29 Pulse Output Variable	null	All set-ups	x	TRUE	-	Uint8
5-65	Pulse Output Max Freq #29	ExpressionLimit	All set-ups	x	TRUE	0	Uint32
5-66	Terminal X30/6 Pulse Output Variable	null	All set-ups		TRUE	-	Uint8
5-68	Pulse Output Max Freq #X30/6	ExpressionLimit	All set-ups		TRUE	0	Uint32
5-7* 24V Encoder Input							
5-70	Term 32/33 Pulses per Revolution	1024 N/A	All set-ups		FALSE	0	Uint16
5-71	Term 32/33 Encoder Direction	[0] Clockwise	All set-ups		FALSE	-	Uint8
5-9* Bus Controlled							
5-90	Digital & Relay Bus Control	0 N/A	All set-ups		TRUE	0	Uint32
5-93	Pulse Out #27 Bus Control	0.00 %	All set-ups		TRUE	-2	N2
5-94	Pulse Out #27 Timeout Preset	0.00 %	1 set-up		TRUE	-2	Uint16
5-95	Pulse Out #29 Bus Control	0.00 %	All set-ups	x	TRUE	-2	N2
5-96	Pulse Out #29 Timeout Preset	0.00 %	1 set-up	x	TRUE	-2	Uint16
5-97	Pulse Out #X30/6 Bus Control	0.00 %	All set-ups		TRUE	-2	N2
5-98	Pulse Out #X30/6 Timeout Preset	0.00 %	1 set-up		TRUE	-2	Uint16

4.3.7 6-** Analog In/Out

Par. No. #	Parameter description	Default value	4-set-up	FC 302 only	Change during operation	Conversion index	Type
6-0* Analog I/O Mode							
6-00	Live Zero Timeout Time	10 s	All set-ups		TRUE	0	Uint8
6-01	Live Zero Timeout Function	[0] Off	All set-ups		TRUE	-	Uint8
6-1* Analog Input 1							
6-10	Terminal 53 Low Voltage	0.07 V	All set-ups		TRUE	-2	Int16
6-11	Terminal 53 High Voltage	10.00 V	All set-ups		TRUE	-2	Int16
6-12	Terminal 53 Low Current	0.14 mA	All set-ups		TRUE	-5	Int16
6-13	Terminal 53 High Current	20.00 mA	All set-ups		TRUE	-5	Int16
6-14	Terminal 53 Low Ref./Feedb. Value	0 ReferenceFeedbackUnit	All set-ups		TRUE	-3	Int32
6-15	Terminal 53 High Ref./Feedb. Value	ExpressionLimit	All set-ups		TRUE	-3	Int32
6-16	Terminal 53 Filter Time Constant	0.001 s	All set-ups		TRUE	-3	Uint16
6-2* Analog Input 2							
6-20	Terminal 54 Low Voltage	0.07 V	All set-ups		TRUE	-2	Int16
6-21	Terminal 54 High Voltage	10.00 V	All set-ups		TRUE	-2	Int16
6-22	Terminal 54 Low Current	0.14 mA	All set-ups		TRUE	-5	Int16
6-23	Terminal 54 High Current	20.00 mA	All set-ups		TRUE	-5	Int16
6-24	Terminal 54 Low Ref./Feedb. Value	0 ReferenceFeedbackUnit	All set-ups		TRUE	-3	Int32
6-25	Terminal 54 High Ref./Feedb. Value	ExpressionLimit	All set-ups		TRUE	-3	Int32
6-26	Terminal 54 Filter Time Constant	0.001 s	All set-ups		TRUE	-3	Uint16
6-3* Analog Input 53							
6-30	Terminal X30/11 Low Voltage	0.07 V	All set-ups		TRUE	-2	Int16
6-31	Terminal X30/11 High Voltage	10.00 V	All set-ups		TRUE	-2	Int16
6-34	Term. X30/11 Low Ref./Feedb. Value	0 ReferenceFeedbackUnit	All set-ups		TRUE	-3	Int32
6-35	Term. X30/11 High Ref./Feedb. Value	ExpressionLimit	All set-ups		TRUE	-3	Int32
6-36	Term. X30/11 Filter Time Constant	0.001 s	All set-ups		TRUE	-3	Uint16
6-4* Analog Input 4							
6-40	Terminal X30/12 Low Voltage	0.07 V	All set-ups		TRUE	-2	Int16
6-41	Terminal X30/12 High Voltage	10.00 V	All set-ups		TRUE	-2	Int16
6-44	Term. X30/12 Low Ref./Feedb. Value	0 ReferenceFeedbackUnit	All set-ups		TRUE	-3	Int32
6-45	Term. X30/12 High Ref./Feedb. Value	ExpressionLimit	All set-ups		TRUE	-3	Int32
6-46	Term. X30/12 Filter Time Constant	0.001 s	All set-ups		TRUE	-3	Uint16
6-5* Analog Output 1							
6-50	Terminal 42 Output	null	All set-ups		TRUE	-	Uint8
6-51	Terminal 42 Output Min Scale	0.00 %	All set-ups		TRUE	-2	Int16
6-52	Terminal 42 Output Max Scale	100.00 %	All set-ups		TRUE	-2	Int16
6-53	Terminal 42 Output Bus Control	0.00 %	All set-ups		TRUE	-2	N2
6-54	Terminal 42 Output Timeout Preset	0.00 %	1 set-up		TRUE	-2	Uint16
6-55	Terminal 42 Output Filter	[0] Off	1 set-up		TRUE	-	Uint8
6-6* Analog Output 2							
6-60	Terminal X30/8 Output	null	All set-ups		TRUE	-	Uint8
6-61	Terminal X30/8 Min. Scale	0.00 %	All set-ups		TRUE	-2	Int16
6-62	Terminal X30/8 Max. Scale	100.00 %	All set-ups		TRUE	-2	Int16
6-63	Terminal X30/8 Bus Control	0.00 %	All set-ups		TRUE	-2	N2
6-64	Terminal X30/8 Output Timeout Preset	0.00 %	1 set-up		TRUE	-2	Uint16
6-7* Analog Output 3							
6-70	Terminal X45/1 Output	null	All set-ups		TRUE	-	Uint8
6-71	Terminal X45/1 Min. Scale	0.00 %	All set-ups		TRUE	-2	Int16
6-72	Terminal X45/1 Max. Scale	100.00 %	All set-ups		TRUE	-2	Int16
6-73	Terminal X45/1 Bus Control	0.00 %	All set-ups		TRUE	-2	N2
6-74	Terminal X45/1 Output Timeout Preset	0.00 %	1 set-up		TRUE	-2	Uint16
6-8* Analog Output 4							
6-80	Terminal X45/3 Output	null	All set-ups		TRUE	-	Uint8
6-81	Terminal X45/3 Min. Scale	0.00 %	All set-ups		TRUE	-2	Int16
6-82	Terminal X45/3 Max. Scale	100.00 %	All set-ups		TRUE	-2	Int16
6-83	Terminal X45/3 Bus Control	0.00 %	All set-ups		TRUE	-2	N2
6-84	Terminal X45/3 Output Timeout Preset	0.00 %	1 set-up		TRUE	-2	Uint16

4.3.8 7-** Controllers

Par. No. #	Parameter description	Default value	4-set-up	FC 302 only	Change during operation	Conversion index	Type
7-0* Speed PID Ctrl.							
7-00	Speed PID Feedback Source	null	All set-ups		FALSE	-	Uint8
7-02	Speed PID Proportional Gain	ExpressionLimit	All set-ups		TRUE	-3	Uint16
7-03	Speed PID Integral Time	ExpressionLimit	All set-ups		TRUE	-4	Uint32
7-04	Speed PID Differentiation Time	ExpressionLimit	All set-ups		TRUE	-4	Uint16
7-05	Speed PID Diff. Gain Limit	5.0 N/A	All set-ups		TRUE	-1	Uint16
7-06	Speed PID Lowpass Filter Time	10.0 ms	All set-ups		TRUE	-4	Uint16
7-07	Speed PID Feedback Gear Ratio	1.0000 N/A	All set-ups		FALSE	-4	Uint32
7-08	Speed PID Feed Forward Factor	0 %	All set-ups		FALSE	0	Uint16
7-1* Torque PI Ctrl.							
7-12	Torque PI Proportional Gain	100 %	All set-ups		TRUE	0	Uint16
7-13	Torque PI Integration Time	0.020 s	All set-ups		TRUE	-3	Uint16
7-2* Process Ctrl. Feedb							
7-20	Process CL Feedback 1 Resource	[0] No function	All set-ups		TRUE	-	Uint8
7-22	Process CL Feedback 2 Resource	[0] No function	All set-ups		TRUE	-	Uint8
7-3* Process PID Ctrl.							
7-30	Process PID Normal/Inverse Control	[0] Normal	All set-ups		TRUE	-	Uint8
7-31	Process PID Anti Windup	[1] On	All set-ups		TRUE	-	Uint8
7-32	Process PID Controller Start Value	0 RPM	All set-ups		TRUE	67	Uint16
7-33	Process PID Proportional Gain	0.01 N/A	All set-ups		TRUE	-2	Uint16
7-34	Process PID Integral Time	10000.00 s	All set-ups		TRUE	-2	Uint32
7-35	Process PID Differentiation Time	0.00 s	All set-ups		TRUE	-2	Uint16
7-36	Process PID Differentiation Gain Limit	5.0 N/A	All set-ups		TRUE	-1	Uint16
7-38	Process PID Feed Forward Factor	0 %	All set-ups		TRUE	0	Uint16
7-39	On Reference Bandwidth	5 %	All set-ups		TRUE	0	Uint8
7-4* Adv. Process PID I							
7-40	Process PID I-part Reset	[0] No	All set-ups		TRUE	-	Uint8
7-41	Process PID Output Neg. Clamp	-100 %	All set-ups		TRUE	0	Int16
7-42	Process PID Output Pos. Clamp	100 %	All set-ups		TRUE	0	Int16
7-43	Process PID Gain Scale at Min. Ref.	100 %	All set-ups		TRUE	0	Int16
7-44	Process PID Gain Scale at Max. Ref.	100 %	All set-ups		TRUE	0	Int16
7-45	Process PID Feed Fwd Resource	[0] No function	All set-ups		TRUE	-	Uint8
7-46	Process PID Feed Fwd Normal/ Inv. Ctrl.	[0] Normal	All set-ups		TRUE	-	Uint8
7-49	Process PID Output Normal/ Inv. Ctrl.	[0] Normal	All set-ups		TRUE	-	Uint8
7-5* Adv. Process PID II							
7-50	Process PID Extended PID	[1] Enabled	All set-ups		TRUE	-	Uint8
7-51	Process PID Feed Fwd Gain	1.00 N/A	All set-ups		TRUE	-2	Uint16
7-52	Process PID Feed Fwd Ramp up	0.01 s	All set-ups		TRUE	-2	Uint32
7-53	Process PID Feed Fwd Ramp down	0.01 s	All set-ups		TRUE	-2	Uint32
7-56	Process PID Ref. Filter Time	0.001 s	All set-ups		TRUE	-3	Uint16
7-57	Process PID Fb. Filter Time	0.001 s	All set-ups		TRUE	-3	Uint16

4.3.9 8-** Comm. and Options

Par. No. #	Parameter description	Default value	4-set-up	FC 302 only	Change during operation	Conversion index	Type
8-0* General Settings							
8-01	Control Site	[0] Digital and ctrl. word	All set-ups		TRUE	-	Uint8
8-02	Control Word Source	null	All set-ups		TRUE	-	Uint8
8-03	Control Word Timeout Time	1.0 s	1 set-up		TRUE	-1	Uint32
8-04	Control Word Timeout Function	null	1 set-up		TRUE	-	Uint8
8-05	End-of-Timeout Function	[1] Resume set-up	1 set-up		TRUE	-	Uint8
8-06	Reset Control Word Timeout	[0] Do not reset	All set-ups		TRUE	-	Uint8
8-07	Diagnosis Trigger	[0] Disable	2 set-ups		TRUE	-	Uint8
8-1* Ctrl. Word Settings							
8-10	Control Word Profile	[0] FC profile	All set-ups		TRUE	-	Uint8
8-13	Configurable Status Word STW	null	All set-ups		TRUE	-	Uint8
8-14	Configurable Control Word CTW	[1] Profile default	All set-ups		TRUE	-	Uint8
8-3* FC Port Settings							
8-30	Protocol	[0] FC	1 set-up		TRUE	-	Uint8
8-31	Address	1 N/A	1 set-up		TRUE	0	Uint8
8-32	FC Port Baud Rate	null	1 set-up		TRUE	-	Uint8
8-33	Parity / Stop Bits	[0] Even Parity, 1 Stop Bit	1 set-up		TRUE	-	Uint8
8-35	Minimum Response Delay	10 ms	All set-ups		TRUE	-3	Uint16
8-36	Max Response Delay	ExpressionLimit	1 set-up		TRUE	-3	Uint16
8-37	Max Inter-Char Delay	ExpressionLimit	1 set-up		TRUE	-5	Uint16
8-4* FC MC protocol set							
8-40	Telegram selection	[1] Standard telegram 1	2 set-ups		TRUE	-	Uint8
8-5* Digital/Bus							
8-50	Coasting Select	[3] Logic OR	All set-ups		TRUE	-	Uint8
8-51	Quick Stop Select	[3] Logic OR	All set-ups		TRUE	-	Uint8
8-52	DC Brake Select	[3] Logic OR	All set-ups		TRUE	-	Uint8
8-53	Start Select	[3] Logic OR	All set-ups		TRUE	-	Uint8
8-54	Reverse Select	[3] Logic OR	All set-ups		TRUE	-	Uint8
8-55	Set-up Select	[3] Logic OR	All set-ups		TRUE	-	Uint8
8-56	Preset Reference Select	[3] Logic OR	All set-ups		TRUE	-	Uint8
8-8* FC Port Diagnostics							
8-80	Bus Message Count	0 N/A	All set-ups		TRUE	0	Uint32
8-81	Bus Error Count	0 N/A	All set-ups		TRUE	0	Uint32
8-82	Slave Messages Rcvd	0 N/A	All set-ups		TRUE	0	Uint32
8-83	Slave Error Count	0 N/A	All set-ups		TRUE	0	Uint32
8-9* Bus Jog							
8-90	Bus Jog 1 Speed	100 RPM	All set-ups		TRUE	67	Uint16
8-91	Bus Jog 2 Speed	200 RPM	All set-ups		TRUE	67	Uint16

4.3.10 9-** Profibus

Par. No. #	Parameter description	Default value	4-set-up	FC 302 only	Change during operation	Conversion index	Type
9-00	Setpoint	0 N/A	All set-ups		TRUE	0	Uint16
9-07	Actual Value	0 N/A	All set-ups		FALSE	0	Uint16
9-15	PCD Write Configuration	ExpressionLimit	2 set-ups		TRUE	-	Uint16
9-16	PCD Read Configuration	ExpressionLimit	2 set-ups		TRUE	-	Uint16
9-18	Node Address	126 N/A	1 set-up		TRUE	0	Uint8
9-22	Telegram Selection	[108] PPO 8	1 set-up		TRUE	-	Uint8
9-23	Parameters for Signals	0	All set-ups		TRUE	-	Uint16
9-27	Parameter Edit	[1] Enabled	2 set-ups		FALSE	-	Uint16
9-28	Process Control	[1] Enable cyclic master	2 set-ups		FALSE	-	Uint8
9-44	Fault Message Counter	0 N/A	All set-ups		TRUE	0	Uint16
9-45	Fault Code	0 N/A	All set-ups		TRUE	0	Uint16
9-47	Fault Number	0 N/A	All set-ups		TRUE	0	Uint16
9-52	Fault Situation Counter	0 N/A	All set-ups		TRUE	0	Uint16
9-53	Profibus Warning Word	0 N/A	All set-ups		TRUE	0	V2
9-63	Actual Baud Rate	[255] No baud rate found	All set-ups		TRUE	-	Uint8
9-64	Device Identification	0 N/A	All set-ups		TRUE	0	Uint16
9-65	Profile Number	0 N/A	All set-ups		TRUE	0	Uint16
9-67	Control Word 1	0 N/A	All set-ups		TRUE	0	V2
9-68	Status Word 1	0 N/A	All set-ups		TRUE	0	V2
9-71	Profibus Save Data Values	[0] Off	All set-ups		TRUE	-	Uint8
9-72	ProfibusDriveReset	[0] No action	1 set-up		FALSE	-	Uint8
9-80	Defined Parameters (1)	0 N/A	All set-ups		FALSE	0	Uint16
9-81	Defined Parameters (2)	0 N/A	All set-ups		FALSE	0	Uint16
9-82	Defined Parameters (3)	0 N/A	All set-ups		FALSE	0	Uint16
9-83	Defined Parameters (4)	0 N/A	All set-ups		FALSE	0	Uint16
9-84	Defined Parameters (5)	0 N/A	All set-ups		FALSE	0	Uint16
9-90	Changed Parameters (1)	0 N/A	All set-ups		FALSE	0	Uint16
9-91	Changed Parameters (2)	0 N/A	All set-ups		FALSE	0	Uint16
9-92	Changed Parameters (3)	0 N/A	All set-ups		FALSE	0	Uint16
9-93	Changed Parameters (4)	0 N/A	All set-ups		FALSE	0	Uint16
9-94	Changed parameters (5)	0 N/A	All set-ups		FALSE	0	Uint16
9-99	Profibus Revision Counter	0 N/A	All set-ups		TRUE	0	Uint16

4.3.11 10-** CAN Ser. Com. Bus

Par. No. #	Parameter description	Default value	4-set-up	FC 302 only	Change during operation	Conversion index	Type
10-0* Common Settings							
10-00	CAN Protocol	null	2 set-ups		FALSE	-	UInt8
10-01	Baud Rate Select	null	2 set-ups		TRUE	-	UInt8
10-02	MAC ID	ExpressionLimit	2 set-ups		TRUE	0	UInt8
10-05	Readout Transmit Error Counter	0 N/A	All set-ups		TRUE	0	UInt8
10-06	Readout Receive Error Counter	0 N/A	All set-ups		TRUE	0	UInt8
10-07	Readout Bus Off Counter	0 N/A	All set-ups		TRUE	0	UInt8
10-1* DeviceNet							
10-10	Process Data Type Selection	null	All set-ups		TRUE	-	UInt8
10-11	Process Data Config Write	ExpressionLimit	All set-ups		TRUE	-	UInt16
10-12	Process Data Config Read	ExpressionLimit	All set-ups		TRUE	-	UInt16
10-13	Warning Parameter	0 N/A	All set-ups		TRUE	0	UInt16
10-14	Net Reference	[0] Off	2 set-ups		TRUE	-	UInt8
10-15	Net Control	[0] Off	2 set-ups		TRUE	-	UInt8
10-2* COS Filters							
10-20	COS Filter 1	0 N/A	All set-ups		FALSE	0	UInt16
10-21	COS Filter 2	0 N/A	All set-ups		FALSE	0	UInt16
10-22	COS Filter 3	0 N/A	All set-ups		FALSE	0	UInt16
10-23	COS Filter 4	0 N/A	All set-ups		FALSE	0	UInt16
10-3* Parameter Access							
10-30	Array Index	0 N/A	2 set-ups		TRUE	0	UInt8
10-31	Store Data Values	[0] Off	All set-ups		TRUE	-	UInt8
10-32	Devicenet Revision	ExpressionLimit	All set-ups		TRUE	0	UInt16
10-33	Store Always	[0] Off	1 set-up		TRUE	-	UInt8
10-34	DeviceNet Product Code	ExpressionLimit	1 set-up		TRUE	0	UInt16
10-39	Devicenet F Parameters	0 N/A	All set-ups		TRUE	0	UInt32
10-5* CANopen							
10-50	Process Data Config Write.	ExpressionLimit	2 set-ups		TRUE	-	UInt16
10-51	Process Data Config Read.	ExpressionLimit	2 set-ups		TRUE	-	UInt16

4.3.12 12-** Ethernet

Par. No. #	Parameter description	Default value	4-set-up	FC 302 only	Change during operation	Conversion index	Type
12-0* IP Settings							
12-00	IP Address Assignment	[0] MANUAL	2 set-ups		TRUE	-	Uint8
12-01	IP Address	0 N/A	2 set-ups		TRUE	0	OctStr[4]
12-02	Subnet Mask	0 N/A	2 set-ups		TRUE	0	OctStr[4]
12-03	Default Gateway	0 N/A	2 set-ups		TRUE	0	OctStr[4]
12-04	DHCP Server	0 N/A	2 set-ups		TRUE	0	OctStr[4]
12-05	Lease Expires	ExpressionLimit	All set-ups		TRUE	0	TimD
12-06	Name Servers	0 N/A	2 set-ups		TRUE	0	OctStr[4]
12-07	Domain Name	0 N/A	2 set-ups		TRUE	0	VisStr[48]
12-08	Host Name	0 N/A	2 set-ups		TRUE	0	VisStr[48]
12-09	Physical Address	0 N/A	1 set-up		TRUE	0	VisStr[17]
12-1* Ethernet Link Parameters							
12-10	Link Status	[0] No Link	1 set-up		TRUE	-	Uint8
12-11	Link Duration	ExpressionLimit	All set-ups		TRUE	0	TimD
12-12	Auto Negotiation	[1] On	2 set-ups		TRUE	-	Uint8
12-13	Link Speed	[0] None	2 set-ups		TRUE	-	Uint8
12-14	Link Duplex	[1] Full Duplex	2 set-ups		TRUE	-	Uint8
12-2* Process Data							
12-20	Control Instance	ExpressionLimit	1 set-up		TRUE	0	Uint8
12-21	Process Data Config Write	ExpressionLimit	All set-ups		TRUE	-	Uint16
12-22	Process Data Config Read	ExpressionLimit	All set-ups		TRUE	-	Uint16
12-28	Store Data Values	[0] Off	All set-ups		TRUE	-	Uint8
12-29	Store Always	[0] Off	1 set-up		TRUE	-	Uint8
12-3* EtherNet/IP							
12-30	Warning Parameter	0 N/A	All set-ups		TRUE	0	Uint16
12-31	Net Reference	[0] Off	2 set-ups		TRUE	-	Uint8
12-32	Net Control	[0] Off	2 set-ups		TRUE	-	Uint8
12-33	CIP Revision	ExpressionLimit	All set-ups		TRUE	0	Uint16
12-34	CIP Product Code	ExpressionLimit	1 set-up		TRUE	0	Uint16
12-35	EDS Parameter	0 N/A	All set-ups		TRUE	0	Uint32
12-37	COS Inhibit Timer	0 N/A	All set-ups		TRUE	0	Uint16
12-38	COS Filter	0 N/A	All set-ups		TRUE	0	Uint16
12-8* Other Ethernet Services							
12-80	FTP Server	[0] Disabled	2 set-ups		TRUE	-	Uint8
12-81	HTTP Server	[0] Disabled	2 set-ups		TRUE	-	Uint8
12-82	SMTP Service	[0] Disabled	2 set-ups		TRUE	-	Uint8
12-89	Transparent Socket Channel Port	4000 N/A	2 set-ups		TRUE	0	Uint16
12-9* Advanced Ethernet Services							
12-90	Cable Diagnostic	[0] Disabled	2 set-ups		TRUE	-	Uint8
12-91	MDI-X	[1] Enabled	2 set-ups		TRUE	-	Uint8
12-92	IGMP Snooping	[1] Enabled	2 set-ups		TRUE	-	Uint8
12-93	Cable Error Length	0 N/A	1 set-up		TRUE	0	Uint16
12-94	Broadcast Storm Protection	-1 %	2 set-ups		TRUE	0	Int8
12-95	Broadcast Storm Filter	[0] Broadcast only	2 set-ups		TRUE	-	Uint8
12-98	Interface Counters	4000 N/A	All set-ups		TRUE	0	Uint16
12-99	Media Counters	0 N/A	All set-ups		TRUE	0	Uint16

4.3.13 13-** Smart Logic

Par. No. #	Parameter description	Default value	4-set-up	FC 302 only	Change during operation	Conversion index	Type
13-0* SLC Settings							
13-00	SL Controller Mode	null	2 set-ups		TRUE	-	UInt8
13-01	Start Event	null	2 set-ups		TRUE	-	UInt8
13-02	Stop Event	null	2 set-ups		TRUE	-	UInt8
13-03	Reset SLC	[0] Do not reset SLC	All set-ups		TRUE	-	UInt8
13-1* Comparators							
13-10	Comparator Operand	null	2 set-ups		TRUE	-	UInt8
13-11	Comparator Operator	null	2 set-ups		TRUE	-	UInt8
13-12	Comparator Value	ExpressionLimit	2 set-ups		TRUE	-3	Int32
13-2* Timers							
13-20	SL Controller Timer	ExpressionLimit	1 set-up		TRUE	-3	TimD
13-4* Logic Rules							
13-40	Logic Rule Boolean 1	null	2 set-ups		TRUE	-	UInt8
13-41	Logic Rule Operator 1	null	2 set-ups		TRUE	-	UInt8
13-42	Logic Rule Boolean 2	null	2 set-ups		TRUE	-	UInt8
13-43	Logic Rule Operator 2	null	2 set-ups		TRUE	-	UInt8
13-44	Logic Rule Boolean 3	null	2 set-ups		TRUE	-	UInt8
13-5* States							
13-51	SL Controller Event	null	2 set-ups		TRUE	-	UInt8
13-52	SL Controller Action	null	2 set-ups		TRUE	-	UInt8

4.3.14 14-** Special Functions

Par. No. #	Parameter description	Default value	4-set-up	FC 302 only	Change during operation	Conversion index	Type
14-0* Inverter Switching							
14-00	Switching Pattern	[1] SFAVM	All set-ups		TRUE	-	Uint8
14-01	Switching Frequency	null	All set-ups		TRUE	-	Uint8
14-03	Overmodulation	[1] On	All set-ups		FALSE	-	Uint8
14-04	PWM Random	[0] Off	All set-ups		TRUE	-	Uint8
14-1* Mains On/Off							
14-10	Line Failure	[0] No function	All set-ups		FALSE	-	Uint8
14-11	Line Voltage at Line Fault	ExpressionLimit	All set-ups		TRUE	0	Uint16
14-12	Function at Mains Imbalance	[0] Trip	All set-ups		TRUE	-	Uint8
14-13	Mains Failure Step Factor	1.0 N/A	All set-ups		TRUE	-1	Uint8
14-2* Trip Reset							
14-20	Reset Mode	[0] Manual reset	All set-ups		TRUE	-	Uint8
14-21	Automatic Restart Time	10 s	All set-ups		TRUE	0	Uint16
14-22	Operation Mode	[0] Normal operation	All set-ups		TRUE	-	Uint8
14-23	Typecode Setting	null	2 set-ups		FALSE	-	Uint8
14-24	Trip Delay at Current Limit	60 s	All set-ups		TRUE	0	Uint8
14-25	Trip Delay at Torque Limit	60 s	All set-ups		TRUE	0	Uint8
14-26	Trip Delay at Inverter Fault	ExpressionLimit	All set-ups		TRUE	0	Uint8
14-28	Production Settings	[0] No action	All set-ups		TRUE	-	Uint8
14-29	Service Code	0 N/A	All set-ups		TRUE	0	Int32
14-3* Current Limit Ctrl.							
14-30	Current Lim Contr, Proportional Gain	100 %	All set-ups		FALSE	0	Uint16
14-31	Current Lim Contr, Integration Time	0.020 s	All set-ups		FALSE	-3	Uint16
14-32	Current Lim Ctrl, Filter Time	1.0 ms	All set-ups		TRUE	-4	Uint16
14-35	Stall Protection	[1] Enabled	All set-ups		FALSE	-	Uint8
14-4* Energy Optimizing							
14-40	VT Level	66 %	All set-ups		FALSE	0	Uint8
14-41	AEO Minimum Magnetization	ExpressionLimit	All set-ups		TRUE	0	Uint8
14-42	Minimum AEO Frequency	10 Hz	All set-ups		TRUE	0	Uint8
14-43	Motor Cos-Phi	ExpressionLimit	All set-ups		TRUE	-2	Uint16
14-5* Environment							
14-50	RFI 1	[1] On	1 set-up	x	FALSE	-	Uint8
14-52	Fan Control	[0] Auto	All set-ups		TRUE	-	Uint8
14-53	Fan Monitor	[1] Warning	All set-ups		TRUE	-	Uint8
14-55	Output Filter	[0] No Filter	All set-ups		FALSE	-	Uint8
14-56	Capacitance Output Filter	2.0 uF	All set-ups		FALSE	-7	Uint16
14-57	Inductance Output Filter	7.000 mH	All set-ups		FALSE	-6	Uint16
14-59	Actual Number of Inverter Units	ExpressionLimit	1 set-up		FALSE	0	Uint8
14-7* Compatibility							
14-72	VLT Alarm Word	0 N/A	All set-ups		FALSE	0	Uint32
14-73	VLT Warning Word	0 N/A	All set-ups		FALSE	0	Uint32
14-74	VLT Ext. Status Word	0 N/A	All set-ups		FALSE	0	Uint32
14-8* Options							
14-80	Option Supplied by External 24VDC	[1] Yes	2 set-ups		FALSE	-	Uint8
14-9* Fault Settings							
14-90	Fault Level	null	1 set-up		TRUE	-	Uint8

4.3.15 15-** Drive Information

Par. No. #	Parameter description	Default value	4-set-up	FC 302 only	Change during operation	Conversion index	Type
15-0* Operating Data							
15-00	Operating Hours	0 h	All set-ups		FALSE	74	Uint32
15-01	Running Hours	0 h	All set-ups		FALSE	74	Uint32
15-02	kWh Counter	0 kWh	All set-ups		FALSE	75	Uint32
15-03	Power-ups	0 N/A	All set-ups		FALSE	0	Uint32
15-04	Over Temps	0 N/A	All set-ups		FALSE	0	Uint16
15-05	Over Volts	0 N/A	All set-ups		FALSE	0	Uint16
15-06	Reset kWh Counter	[0] Do not reset	All set-ups		TRUE	-	Uint8
15-07	Reset Running Hours Counter	[0] Do not reset	All set-ups		TRUE	-	Uint8
15-1* Data Log Settings							
15-10	Logging Source	0	2 set-ups		TRUE	-	Uint16
15-11	Logging Interval	ExpressionLimit	2 set-ups		TRUE	-3	TimD
15-12	Trigger Event	[0] FALSE	1 set-up		TRUE	-	Uint8
15-13	Logging Mode	[0] Log always	2 set-ups		TRUE	-	Uint8
15-14	Samples Before Trigger	50 N/A	2 set-ups		TRUE	0	Uint8
15-2* Historic Log							
15-20	Historic Log: Event	0 N/A	All set-ups		FALSE	0	Uint8
15-21	Historic Log: Value	0 N/A	All set-ups		FALSE	0	Uint32
15-22	Historic Log: Time	0 ms	All set-ups		FALSE	-3	Uint32
15-3* Fault Log							
15-30	Fault Log: Error Code	0 N/A	All set-ups		FALSE	0	Uint8
15-31	Fault Log: Value	0 N/A	All set-ups		FALSE	0	Int16
15-32	Fault Log: Time	0 s	All set-ups		FALSE	0	Uint32
15-4* Drive Identification							
15-40	FC Type	0 N/A	All set-ups		FALSE	0	VisStr[6]
15-41	Power Section	0 N/A	All set-ups		FALSE	0	VisStr[20]
15-42	Voltage	0 N/A	All set-ups		FALSE	0	VisStr[20]
15-43	Software Version	0 N/A	All set-ups		FALSE	0	VisStr[5]
15-44	Ordered Typecode String	0 N/A	All set-ups		FALSE	0	VisStr[40]
15-45	Actual Typecode String	0 N/A	All set-ups		FALSE	0	VisStr[40]
15-46	Adj Freq Dr Ordering No.	0 N/A	All set-ups		FALSE	0	VisStr[8]
15-47	Power Card Ordering No.	0 N/A	All set-ups		FALSE	0	VisStr[8]
15-48	LCP ID Num.	0 N/A	All set-ups		FALSE	0	VisStr[20]
15-49	SW ID Control Card	0 N/A	All set-ups		FALSE	0	VisStr[20]
15-50	SW ID Power Card	0 N/A	All set-ups		FALSE	0	VisStr[20]
15-51	Adj Freq Dr Serial No.	0 N/A	All set-ups		FALSE	0	VisStr[10]
15-53	Power Card Serial Number	0 N/A	All set-ups		FALSE	0	VisStr[19]
15-6* Option Ident							
15-60	Option Mounted	0 N/A	All set-ups		FALSE	0	VisStr[30]
15-61	Option SW Version	0 N/A	All set-ups		FALSE	0	VisStr[20]
15-62	Option Ordering No	0 N/A	All set-ups		FALSE	0	VisStr[8]
15-63	Option Serial No	0 N/A	All set-ups		FALSE	0	VisStr[18]
15-70	Option in Slot A	0 N/A	All set-ups		FALSE	0	VisStr[30]
15-71	Slot A Option SW Version	0 N/A	All set-ups		FALSE	0	VisStr[20]
15-72	Option in Slot B	0 N/A	All set-ups		FALSE	0	VisStr[30]
15-73	Slot B Option SW Version	0 N/A	All set-ups		FALSE	0	VisStr[20]
15-74	Option in Slot C0	0 N/A	All set-ups		FALSE	0	VisStr[30]
15-75	Slot C0 Option SW Version	0 N/A	All set-ups		FALSE	0	VisStr[20]
15-76	Option in Slot C1	0 N/A	All set-ups		FALSE	0	VisStr[30]
15-77	Slot C1 Option SW Version	0 N/A	All set-ups		FALSE	0	VisStr[20]
15-9* Parameter Info							
15-92	Defined Parameters	0 N/A	All set-ups		FALSE	0	Uint16
15-93	Modified Parameters	0 N/A	All set-ups		FALSE	0	Uint16
15-98	Drive Identification	0 N/A	All set-ups		FALSE	0	VisStr[40]
15-99	Parameter Metadata	0 N/A	All set-ups		FALSE	0	Uint16

4.3.16 16-** Data Readouts

Par. No. #	Parameter description	Default value	4-set-up	FC 302 only	Change during operation	Conversion index	Type
16-0* General Status							
16-00	Control Word	0 N/A	All set-ups		FALSE	0	V2
16-01	Reference [Unit]	0.000 ReferenceFeedbackUnit	All set-ups		FALSE	-3	Int32
16-02	Reference %	0.0 %	All set-ups		FALSE	-1	Int16
16-03	Status Word	0 N/A	All set-ups		FALSE	0	V2
16-05	Main Actual Value [%]	0.00 %	All set-ups		FALSE	-2	N2
16-09	Custom Readout	0.00 CustomReadoutUnit	All set-ups		FALSE	-2	Int32
16-1* Motor Status							
16-10	Power [kW]	0.00 kW	All set-ups		FALSE	1	Int32
16-11	Power [hp]	0.00 hp	All set-ups		FALSE	-2	Int32
16-12	Motor voltage	0.0 V	All set-ups		FALSE	-1	Uint16
16-13	Frequency	0.0 Hz	All set-ups		FALSE	-1	Uint16
16-14	Motor Current	0.00 A	All set-ups		FALSE	-2	Int32
16-15	Frequency [%]	0.00 %	All set-ups		FALSE	-2	N2
16-16	Torque [Nm]	0.0 Nm	All set-ups		FALSE	-1	Int16
16-17	Speed [RPM]	0 RPM	All set-ups		FALSE	67	Int32
16-18	Motor Thermal	0 %	All set-ups		FALSE	0	Uint8
16-19	KTY sensor temperature	0 °C	All set-ups		FALSE	100	Int16
16-20	Motor Angle	0 N/A	All set-ups		TRUE	0	Uint16
16-22	Torque [%]	0 %	All set-ups		FALSE	0	Int16
16-25	Torque [Nm] High	0.0 Nm	All set-ups		FALSE	-1	Int32
16-3* Drive Status							
16-30	DC Link Voltage	0 V	All set-ups		FALSE	0	Uint16
16-32	Brake Energy /s	0.000 kW	All set-ups		FALSE	0	Uint32
16-33	Brake Energy /2 min	0.000 kW	All set-ups		FALSE	0	Uint32
16-34	Heatsink Temp.	0 °C	All set-ups		FALSE	100	Uint8
16-35	Inverter Thermal	0 %	All set-ups		FALSE	0	Uint8
16-36	Inv. Nom. Current	ExpressionLimit	All set-ups		FALSE	-2	Uint32
16-37	Inv. Max. Current	ExpressionLimit	All set-ups		FALSE	-2	Uint32
16-38	SL Controller State	0 N/A	All set-ups		FALSE	0	Uint8
16-39	Control Card Temp.	0 °C	All set-ups		FALSE	100	Uint8
16-40	Logging Buffer Full	[0] No	All set-ups		TRUE	-	Uint8
16-41	LCP Bottom Statusline	0 N/A	All set-ups		TRUE	0	VisStr[50]
16-5* Ref. & Feedb.							
16-50	External Reference	0.0 N/A	All set-ups		FALSE	-1	Int16
16-51	Pulse Reference	0.0 N/A	All set-ups		FALSE	-1	Int16
16-52	Feedback [Unit]	0.000 ReferenceFeedbackUnit	All set-ups		FALSE	-3	Int32
16-53	Digi Pot Reference	0.00 N/A	All set-ups		FALSE	-2	Int16
16-6* Inputs & Outputs							
16-60	Digital Input	0 N/A	All set-ups		FALSE	0	Uint16
16-61	Terminal 53 Switch Setting	[0] Current	All set-ups		FALSE	-	Uint8
16-62	Analog Input 53	0.000 N/A	All set-ups		FALSE	-3	Int32
16-63	Terminal 54 Switch Setting	[0] Current	All set-ups		FALSE	-	Uint8
16-64	Analog Input 54	0.000 N/A	All set-ups		FALSE	-3	Int32
16-65	Analog Output 42 [mA]	0.000 N/A	All set-ups		FALSE	-3	Int16
16-66	Digital Output [bin]	0 N/A	All set-ups		FALSE	0	Uint16
16-67	Freq. Input #29 [Hz]	0 N/A	All set-ups	x	FALSE	0	Int32
16-68	Freq. Input #33 [Hz]	0 N/A	All set-ups		FALSE	0	Int32
16-69	Pulse Output #27 [Hz]	0 N/A	All set-ups		FALSE	0	Int32
16-70	Pulse Output #29 [Hz]	0 N/A	All set-ups	x	FALSE	0	Int32
16-71	Relay Output [bin]	0 N/A	All set-ups		FALSE	0	Int16
16-72	Counter A	0 N/A	All set-ups		TRUE	0	Int32
16-73	Counter B	0 N/A	All set-ups		TRUE	0	Int32
16-74	Prec. Stop Counter	0 N/A	All set-ups		TRUE	0	Uint32
16-75	Analog In X30/11	0.000 N/A	All set-ups		FALSE	-3	Int32
16-76	Analog In X30/12	0.000 N/A	All set-ups		FALSE	-3	Int32
16-77	Analog Out X30/8 [mA]	0.000 N/A	All set-ups		FALSE	-3	Int16
16-78	Analog Out X45/1 [mA]	0.000 N/A	All set-ups		FALSE	-3	Int16
16-79	Analog Out X45/3 [mA]	0.000 N/A	All set-ups		FALSE	-3	Int16
16-8* Fieldbus & FC Port							
16-80	Fieldbus CTW 1	0 N/A	All set-ups		FALSE	0	V2
16-82	Fieldbus REF 1	0 N/A	All set-ups		FALSE	0	N2
16-84	Comm. Option Status	0 N/A	All set-ups		FALSE	0	V2
16-85	FC Port CTW 1	0 N/A	All set-ups		FALSE	0	V2
16-86	FC Port REF 1	0 N/A	All set-ups		FALSE	0	N2
16-9* Diagnosis Readouts							
16-90	Alarm Word	0 N/A	All set-ups		FALSE	0	Uint32
16-91	Alarm word 2	0 N/A	All set-ups		FALSE	0	Uint32
16-92	Warning Word	0 N/A	All set-ups		FALSE	0	Uint32
16-93	Warning word 2	0 N/A	All set-ups		FALSE	0	Uint32
16-94	Ext. Status Word	0 N/A	All set-ups		FALSE	0	Uint32

4.3.17 17-** Motor Feedb.Option

Par. No. #	Parameter description	Default value	4-set-up	FC 302 only	Change during operation	Conversion index	Type
17-1* Inc. Enc. Interface							
17-10	Signal Type	[1] TTL (5V, RS4222)	All set-ups		FALSE	-	Uint8
17-11	Resolution (PPR)	1024 N/A	All set-ups		FALSE	0	Uint16
17-2* Abs. Enc. Interface							
17-20	Protocol Selection	[0] None	All set-ups		FALSE	-	Uint8
17-21	Resolution (Positions/Rev)	ExpressionLimit	All set-ups		FALSE	0	Uint32
17-24	SSI Data Length	13 N/A	All set-ups		FALSE	0	Uint8
17-25	Clock Rate	ExpressionLimit	All set-ups		FALSE	3	Uint16
17-26	SSI Data Format	[0] Gray code	All set-ups		FALSE	-	Uint8
17-34	HIPERFACE Baud rate	[4] 9600	All set-ups		FALSE	-	Uint8
17-5* Resolver Interface							
17-50	Poles	2 N/A	1 set-up		FALSE	0	Uint8
17-51	Input Voltage	7.0 V	1 set-up		FALSE	-1	Uint8
17-52	Input Frequency	10.0 kHz	1 set-up		FALSE	2	Uint8
17-53	Transformation Ratio	0.5 N/A	1 set-up		FALSE	-1	Uint8
17-59	Resolver Interface	[0] Disabled	All set-ups		FALSE	-	Uint8
17-6* Monitoring and App.							
17-60	Feedback Direction	[0] Clockwise	All set-ups		FALSE	-	Uint8
17-61	Feedback Signal Monitoring	[1] Warning	All set-ups		TRUE	-	Uint8

4.3.18 18-** Data Readouts 2

Par. No. #	Parameter description	Default value	4-set-up	FC 302 only	Change during operation	Conversion index	Type
18-90 PID Readouts							
18-90	Process PID Error	0.0 %	All set-ups		FALSE	-1	Int16
18-91	Process PID Output	0.0 %	All set-ups		FALSE	-1	Int16
18-92	Process PID Clamped Output	0.0 %	All set-ups		FALSE	-1	Int16
18-93	Process PID Gain Scaled Output	0.0 %	All set-ups		FALSE	-1	Int16

4.3.19 30-** Special Features

Par. No. #	Parameter description	Default value	4-set-up	FC 302 only	Change during operation	Conversion index	Type
30-0* Wobbler							
30-00	Wobble Mode	[0] Abs. Freq., Abs. Time	All set-ups		FALSE	-	Uint8
30-01	Wobble Delta Frequency [Hz]	5.0 Hz	All set-ups		TRUE	-1	Uint8
30-02	Wobble Delta Frequency [%]	25 %	All set-ups		TRUE	0	Uint8
30-03	Wobble Delta Freq. Scaling Resource	[0] No function	All set-ups		TRUE	-	Uint8
30-04	Wobble Jump Frequency [Hz]	0.0 Hz	All set-ups		TRUE	-1	Uint8
30-05	Wobble Jump Frequency [%]	0 %	All set-ups		TRUE	0	Uint8
30-06	Wobble Jump Time	ExpressionLimit	All set-ups		TRUE	-3	Uint16
30-07	Wobble Sequence Time	10.0 s	All set-ups		TRUE	-1	Uint16
30-08	Wobble Up/ Down Time	5.0 s	All set-ups		TRUE	-1	Uint16
30-09	Wobble Random Function	[0] Off	All set-ups		TRUE	-	Uint8
30-10	Wobble Ratio	1.0 N/A	All set-ups		TRUE	-1	Uint8
30-11	Wobble Random Ratio Max.	10.0 N/A	All set-ups		TRUE	-1	Uint8
30-12	Wobble Random Ratio Min.	0.1 N/A	All set-ups		TRUE	-1	Uint8
30-19	Wobble Delta Freq. Scaled	0.0 Hz	All set-ups		FALSE	-1	Uint16
30-8* Compatibility (I)							
30-80	d-axis Inductance (Ld)	ExpressionLimit	All set-ups		FALSE	-6	Int32
30-81	Brake Resistor (ohm)	ExpressionLimit	All set-ups		TRUE	-2	Uint32
30-83	Speed PID Proportional Gain	ExpressionLimit	All set-ups		TRUE	-4	Uint32
30-84	Process PID Proportional Gain	0.100 N/A	All set-ups		TRUE	-3	Uint16

4.3.20 32-** MCO Basic Settings

Par. No. #	Parameter description	Default value	4-set-up	FC 302 only	Change during operation	Conversion index	Type
32-0* Encoder 2							
32-00	Incremental Signal Type	[1] TTL (5V, RS4222)	2 set-ups		TRUE	-	Uint8
32-01	Incremental Resolution	1024 N/A	2 set-ups		TRUE	0	Uint32
32-02	Absolute Protocol	[0] None	2 set-ups		TRUE	-	Uint8
32-03	Absolute Resolution	8192 N/A	2 set-ups		TRUE	0	Uint32
32-05	Absolute Encoder Data Length	25 N/A	2 set-ups		TRUE	0	Uint8
32-06	Absolute Encoder Clock Frequency	262.000 kHz	2 set-ups		TRUE	0	Uint32
32-07	Absolute Encoder Clock Generation	[1] On	2 set-ups		TRUE	-	Uint8
32-08	Absolute Encoder Cable Length	0 m	2 set-ups		TRUE	0	Uint16
32-09	Encoder Monitoring	[0] Off	2 set-ups		TRUE	-	Uint8
32-10	Rotational Direction	[1] No action	2 set-ups		TRUE	-	Uint8
32-11	User Unit Denominator	1 N/A	2 set-ups		TRUE	0	Uint32
32-12	User Unit Numerator	1 N/A	2 set-ups		TRUE	0	Uint32
32-3* Encoder 1							
32-30	Incremental Signal Type	[1] TTL (5V, RS4222)	2 set-ups		TRUE	-	Uint8
32-31	Incremental Resolution	1024 N/A	2 set-ups		TRUE	0	Uint32
32-32	Absolute Protocol	[0] None	2 set-ups		TRUE	-	Uint8
32-33	Absolute Resolution	8192 N/A	2 set-ups		TRUE	0	Uint32
32-35	Absolute Encoder Data Length	25 N/A	2 set-ups		TRUE	0	Uint8
32-36	Absolute Encoder Clock Frequency	262.000 kHz	2 set-ups		TRUE	0	Uint32
32-37	Absolute Encoder Clock Generation	[1] On	2 set-ups		TRUE	-	Uint8
32-38	Absolute Encoder Cable Length	0 m	2 set-ups		TRUE	0	Uint16
32-39	Encoder Monitoring	[0] Off	2 set-ups		TRUE	-	Uint8
32-40	Encoder Termination	[1] On	2 set-ups		TRUE	-	Uint8
32-5* Feedback Source							
32-50	Source Slave	[2] Encoder 2	2 set-ups		TRUE	-	Uint8
32-51	MCO 302 Last Will	[1] Trip	2 set-ups		TRUE	-	Uint8
32-6* PID Controller							
32-60	Proportional factor	30 N/A	2 set-ups		TRUE	0	Uint32
32-61	Derivative factor	0 N/A	2 set-ups		TRUE	0	Uint32
32-62	Integral factor	0 N/A	2 set-ups		TRUE	0	Uint32
32-63	Limit Value for Integral Sum	1000 N/A	2 set-ups		TRUE	0	Uint16
32-64	PID Bandwidth	1000 N/A	2 set-ups		TRUE	0	Uint16
32-65	Velocity Feed-Forward	0 N/A	2 set-ups		TRUE	0	Uint32
32-66	Acceleration Feed-Forward	0 N/A	2 set-ups		TRUE	0	Uint32
32-67	Max. Tolerated Position Error	20000 N/A	2 set-ups		TRUE	0	Uint32
32-68	Reverse Behavior for Slave	[0] Reversing allowed	2 set-ups		TRUE	-	Uint8
32-69	Sampling Time for PID Control	1 ms	2 set-ups		TRUE	-3	Uint16
32-70	Scan Time for Profile Generator	1 ms	2 set-ups		TRUE	-3	Uint8
32-71	Size of the Control Window (Activation)	0 N/A	2 set-ups		TRUE	0	Uint32
32-72	Size of the Control Window (Deactiv.)	0 N/A	2 set-ups		TRUE	0	Uint32
32-8* Velocity & Accel.							
32-80	Maximum Velocity (Encoder)	1500 RPM	2 set-ups		TRUE	67	Uint32
32-81	Shortest Ramp	1.000 s	2 set-ups		TRUE	-3	Uint32
32-82	Ramp Type	[0] Linear	2 set-ups		TRUE	-	Uint8
32-83	Velocity Resolution	100 N/A	2 set-ups		TRUE	0	Uint32
32-84	Default Velocity	50 N/A	2 set-ups		TRUE	0	Uint32
32-85	Default Acceleration	50 N/A	2 set-ups		TRUE	0	Uint32
32-9* Development							
32-90	Debug Source	[0] Controlcard	2 set-ups		TRUE	-	Uint8

4.3.21 33-** MCO Adv. Settings

Par. No. #	Parameter description	Default value	4-set-up	FC 302 only	Change during operation	Conversion index	Type
33-0* Home Motion							
33-00	Force HOME	[0] Home not forced	2 set-ups		TRUE	-	Uint8
33-01	Zero Point Offset from Home Pos.	0 N/A	2 set-ups		TRUE	0	Int32
33-02	Ramp for Home Motion	10 N/A	2 set-ups		TRUE	0	Int32
33-03	Velocity of Home Motion	10 N/A	2 set-ups		TRUE	0	Int32
33-04	Behavior during Home Motion	[0] Reverse and index	2 set-ups		TRUE	-	Uint8
33-1* Synchronization							
33-10	Synchronization Factor Master (M:S)	1 N/A	2 set-ups		TRUE	0	Int32
33-11	Synchronization Factor Slave (M:S)	1 N/A	2 set-ups		TRUE	0	Int32
33-12	Position Offset for Synchronization	0 N/A	2 set-ups		TRUE	0	Int32
33-13	Accuracy Window for Position Sync.	1000 N/A	2 set-ups		TRUE	0	Int32
33-14	Relative Slave Velocity Limit	0 %	2 set-ups		TRUE	0	Uint8
33-15	Marker Number for Master	1 N/A	2 set-ups		TRUE	0	Uint16
33-16	Marker Number for Slave	1 N/A	2 set-ups		TRUE	0	Uint16
33-17	Master Marker Distance	4096 N/A	2 set-ups		TRUE	0	Int32
33-18	Slave Marker Distance	4096 N/A	2 set-ups		TRUE	0	Int32
33-19	Master Marker Type	[0] Encoder Z positive	2 set-ups		TRUE	-	Uint8
33-20	Slave Marker Type	[0] Encoder Z positive	2 set-ups		TRUE	-	Uint8
33-21	Master Marker Tolerance Window	0 N/A	2 set-ups		TRUE	0	Int32
33-22	Slave Marker Tolerance Window	0 N/A	2 set-ups		TRUE	0	Int32
33-23	Start Behavior for Marker Sync	[0] Start Function 1	2 set-ups		TRUE	-	Uint16
33-24	Marker Number for Fault	10 N/A	2 set-ups		TRUE	0	Uint16
33-25	Marker Number for Ready	1 N/A	2 set-ups		TRUE	0	Uint16
33-26	Velocity Filter	0 us	2 set-ups		TRUE	-6	Int32
33-27	Offset Filter Time	0 ms	2 set-ups		TRUE	-3	Int32
33-28	Marker Filter Configuration	[0] Marker filter 1	2 set-ups		TRUE	-	Uint8
33-29	Filter Time for Marker Filter	0 ms	2 set-ups		TRUE	-3	Int32
33-30	Maximum Marker Correction	0 N/A	2 set-ups		TRUE	0	Int32
33-31	Synchronization Type	[0] Standard	2 set-ups		TRUE	-	Uint8
33-4* Limit Handling							
33-40	Behavior at End Limit Switch	[0] Call error handler	2 set-ups		TRUE	-	Uint8
33-41	Negative Software End Limit	-500000 N/A	2 set-ups		TRUE	0	Int32
33-42	Positive Software End Limit	500000 N/A	2 set-ups		TRUE	0	Int32
33-43	Negative Software End Limit Active	[0] Inactive	2 set-ups		TRUE	-	Uint8
33-44	Positive Software End Limit Active	[0] Inactive	2 set-ups		TRUE	-	Uint8
33-45	Time in Target Window	0 ms	2 set-ups		TRUE	-3	Uint8
33-46	Target Window LimitValue	1 N/A	2 set-ups		TRUE	0	Uint16
33-47	Size of Target Window	0 N/A	2 set-ups		TRUE	0	Uint16
33-5* I/O Configuration							
33-50	Terminal X57/1 Digital Input	[0] No function	2 set-ups		TRUE	-	Uint8
33-51	Terminal X57/2 Digital Input	[0] No function	2 set-ups		TRUE	-	Uint8
33-52	Terminal X57/3 Digital Input	[0] No function	2 set-ups		TRUE	-	Uint8
33-53	Terminal X57/4 Digital Input	[0] No function	2 set-ups		TRUE	-	Uint8
33-54	Terminal X57/5 Digital Input	[0] No function	2 set-ups		TRUE	-	Uint8
33-55	Terminal X57/6 Digital Input	[0] No function	2 set-ups		TRUE	-	Uint8
33-56	Terminal X57/7 Digital Input	[0] No function	2 set-ups		TRUE	-	Uint8
33-57	Terminal X57/8 Digital Input	[0] No function	2 set-ups		TRUE	-	Uint8
33-58	Terminal X57/9 Digital Input	[0] No function	2 set-ups		TRUE	-	Uint8
33-59	Terminal X57/10 Digital Input	[0] No function	2 set-ups		TRUE	-	Uint8
33-60	Terminal X59/1 and X59/2 Mode	[1] Output	2 set-ups		FALSE	-	Uint8
33-61	Terminal X59/1 Digital Input	[0] No function	2 set-ups		TRUE	-	Uint8
33-62	Terminal X59/2 Digital Input	[0] No function	2 set-ups		TRUE	-	Uint8
33-63	Terminal X59/1 Digital Output	[0] No function	2 set-ups		TRUE	-	Uint8
33-64	Terminal X59/2 Digital Output	[0] No function	2 set-ups		TRUE	-	Uint8
33-65	Terminal X59/3 Digital Output	[0] No function	2 set-ups		TRUE	-	Uint8
33-66	Terminal X59/4 Digital Output	[0] No function	2 set-ups		TRUE	-	Uint8
33-67	Terminal X59/5 Digital Output	[0] No function	2 set-ups		TRUE	-	Uint8
33-68	Terminal X59/6 Digital Output	[0] No function	2 set-ups		TRUE	-	Uint8
33-69	Terminal X59/7 Digital Output	[0] No function	2 set-ups		TRUE	-	Uint8
33-70	Terminal X59/8 Digital Output	[0] No function	2 set-ups		TRUE	-	Uint8
33-8* Global Parameters							
33-80	Activated Program Number	-1 N/A	2 set-ups		TRUE	0	Int8
33-81	Power-up State	[1] Motor ON	2 set-ups		TRUE	-	Uint8
33-82	Drive Status Monitoring	[1] On	2 set-ups		TRUE	-	Uint8
33-83	Behavior After Error	[0] Coast	2 set-ups		TRUE	-	Uint8
33-84	Behavior afterEsc.	[0] Controlled stop	2 set-ups		TRUE	-	Uint8
33-85	MCO Supplied by External 24VDC	[0] No	2 set-ups		TRUE	-	Uint8
33-86	Terminal at alarm	[0] Relay 1	2 set-ups		TRUE	-	Uint8
33-87	Terminal state at alarm	[0] Do nothing	2 set-ups		TRUE	-	Uint8
33-88	Status word at alarm	0 N/A	2 set-ups		TRUE	0	Uint16

4.3.22 34-** MCO Data Readouts

Par. No. #	Parameter description	Default value	4-set-up	FC 302 only	Change during operation	Conversion index	Type
34-0* PCD Write Par.							
34-01	PCD 1 Write to MCO	0 N/A	All set-ups		TRUE	0	Uint16
34-02	PCD 2 Write to MCO	0 N/A	All set-ups		TRUE	0	Uint16
34-03	PCD 3 Write to MCO	0 N/A	All set-ups		TRUE	0	Uint16
34-04	PCD 4 Write to MCO	0 N/A	All set-ups		TRUE	0	Uint16
34-05	PCD 5 Write to MCO	0 N/A	All set-ups		TRUE	0	Uint16
34-06	PCD 6 Write to MCO	0 N/A	All set-ups		TRUE	0	Uint16
34-07	PCD 7 Write to MCO	0 N/A	All set-ups		TRUE	0	Uint16
34-08	PCD 8 Write to MCO	0 N/A	All set-ups		TRUE	0	Uint16
34-09	PCD 9 Write to MCO	0 N/A	All set-ups		TRUE	0	Uint16
34-10	PCD 10 Write to MCO	0 N/A	All set-ups		TRUE	0	Uint16
34-2* PCD Read Par.							
34-21	PCD 1 Read from MCO	0 N/A	All set-ups		TRUE	0	Uint16
34-22	PCD 2 Read from MCO	0 N/A	All set-ups		TRUE	0	Uint16
34-23	PCD 3 Read from MCO	0 N/A	All set-ups		TRUE	0	Uint16
34-24	PCD 4 Read from MCO	0 N/A	All set-ups		TRUE	0	Uint16
34-25	PCD 5 Read from MCO	0 N/A	All set-ups		TRUE	0	Uint16
34-26	PCD 6 Read from MCO	0 N/A	All set-ups		TRUE	0	Uint16
34-27	PCD 7 Read from MCO	0 N/A	All set-ups		TRUE	0	Uint16
34-28	PCD 8 Read from MCO	0 N/A	All set-ups		TRUE	0	Uint16
34-29	PCD 9 Read from MCO	0 N/A	All set-ups		TRUE	0	Uint16
34-30	PCD 10 Read from MCO	0 N/A	All set-ups		TRUE	0	Uint16
34-4* Inputs & Outputs							
34-40	Digital Inputs	0 N/A	All set-ups		TRUE	0	Uint16
34-41	Digital Outputs	0 N/A	All set-ups		TRUE	0	Uint16
34-5* Process Data							
34-50	Actual Position	0 N/A	All set-ups		TRUE	0	Int32
34-51	Commanded Position	0 N/A	All set-ups		TRUE	0	Int32
34-52	Actual Master Position	0 N/A	All set-ups		TRUE	0	Int32
34-53	Slave Index Position	0 N/A	All set-ups		TRUE	0	Int32
34-54	Master Index Position	0 N/A	All set-ups		TRUE	0	Int32
34-55	Curve Position	0 N/A	All set-ups		TRUE	0	Int32
34-56	Track Error	0 N/A	All set-ups		TRUE	0	Int32
34-57	Synchronizing Error	0 N/A	All set-ups		TRUE	0	Int32
34-58	Actual Velocity	0 N/A	All set-ups		TRUE	0	Int32
34-59	Actual Master Velocity	0 N/A	All set-ups		TRUE	0	Int32
34-60	Synchronizing Status	0 N/A	All set-ups		TRUE	0	Int32
34-61	Axis Status	0 N/A	All set-ups		TRUE	0	Int32
34-62	Program Status	0 N/A	All set-ups		TRUE	0	Int32
34-64	MCO 302 Status	0 N/A	All set-ups		TRUE	0	Uint16
34-65	MCO 302 Control	0 N/A	All set-ups		TRUE	0	Uint16
34-7* Diagnosis readouts							
34-70	MCO Alarm Word 1	0 N/A	All set-ups		FALSE	0	Uint32
34-71	MCO Alarm Word 2	0 N/A	All set-ups		FALSE	0	Uint32

5 General Specifications

Line power supply (L1, L2, L3):

Supply voltage	FC 302: 380–500 V ±10%
Supply voltage	FC 302: 525–690 V ±10%

AC line voltage low / line drop-out:

During low AC line voltage or a line drop-out, the adjustable frequency drive continues until the intermediate circuit voltage drops below the minimum stop level, which corresponds typically to 15% below the adjustable frequency drive's lowest rated supply voltage. Power-up and full torque cannot be expected at AC line voltage lower than 10% below the adjustable frequency drive's lowest rated supply voltage.

Supply frequency	50/60 Hz ±5%
Max. imbalance temporary between line phases	3.0% of rated supply voltage
True Power Factor (λ)	≥ 0.9 nominal at rated load
Displacement Power Factor ($\cos \phi$) near unity	(> 0.98)
Switching on input supply L1, L2, L3 (power-ups)	maximum 1 time/ 2 min.
Environment according to EN60664-1	overvoltage category III/pollution degree 2

The unit is suitable for use on a circuit capable of delivering not more than 100,000 RMS symmetrical Amperes, 500/600/690 V maximum.

Motor output (U, V, W):

Output voltage	0–100% of supply voltage
Output frequency	0–800* Hz
Switching on output	Unlimited
Ramp times	0.01–3600 sec.

* Voltage and power dependent

Torque characteristics:

Starting torque (Constant torque)	maximum 160% for 60 sec.*
Starting torque	maximum 180% up to 0.5 sec.*
Overload torque (Constant torque)	maximum 160% for 60 sec.*
Starting torque (Variable torque)	maximum 110% for 60 sec.*
Overload torque (Variable torque)	maximum 110% for 60 sec.

*Percentage relates to the nominal torque.

Digital inputs:

Programmable digital inputs	4 (6)
Terminal number	18, 19, 27 ¹⁾ , 29, 32, 33,
Logic	PNP or NPN
Voltage level	0–24 V DC
Voltage level, logic '0' PNP	< 5 V DC
Voltage level, logic '1' PNP	> 10 V DC
Voltage level, logic '0' NPN ²⁾	> 19 V DC
Voltage level, logic '1' NPN ²⁾	< 14 V DC
Maximum voltage on input	28 V DC
Pulse frequency range	0–110 kHz
(Duty cycle) Min. pulse width	4.5 ms
Input resistance, R _i	approx. 4 kΩ

Safe stop Terminal 37³⁾ (Terminal 37 is fixed PNP logic):

Voltage level	0–24 V DC
Voltage level, logic'0' PNP	< 4 V DC
Voltage level, logic'1' PNP	>20 V DC
Nominal input current at 24 V	50 mA rms
Nominal input current at 20 V	60 mA rms
Input capacitance	400 nF

All digital inputs are galvanically isolated from the supply voltage (PELV) and other high-voltage terminals.

1) Terminals 27 and 29 can also be programmed as output.

2) Except safe stop input Terminal 37.

3) Terminal 37 can only be used as safe stop input. Terminal 37 is suitable for category 3 installations in accordance with EN 954-1 (safe stop according to category 0 EN 60204-1), and as required by the EU Machinery Directive 98/37/EC. Terminal 37 and the safe stop function are designed in accordance with EN 60204-1, EN 50178, EN 61800-2, EN 61800-3 and EN 954-1. For correct and safe use of the Safe Stop function, follow the related information and instructions in the Design Guide.

5

Analog inputs:

Number of analog inputs	2
Terminal number	53, 54
Modes	Voltage or current
Mode select	Switch S201 and switch S202
Voltage mode	Switch S201/switch S202 = OFF (U)
Voltage level	-10 to +10 V (scaleable)
Input resistance, R_i	approx. 10 k Ω
Max. voltage	± 20 V
Current mode	Switch S201/switch S202 = ON (I)
Current level	0/4 to 20 mA (scaleable)
Input resistance, R_i	approx. 200 Ω
Max. current	30 mA
Resolution for analog inputs	10 bit (+ sign)
Accuracy of analog inputs	Max. error 0.5% of full scale
Bandwidth	100 Hz

The analog inputs are galvanically isolated from the supply voltage (PELV) and other high-voltage terminals.

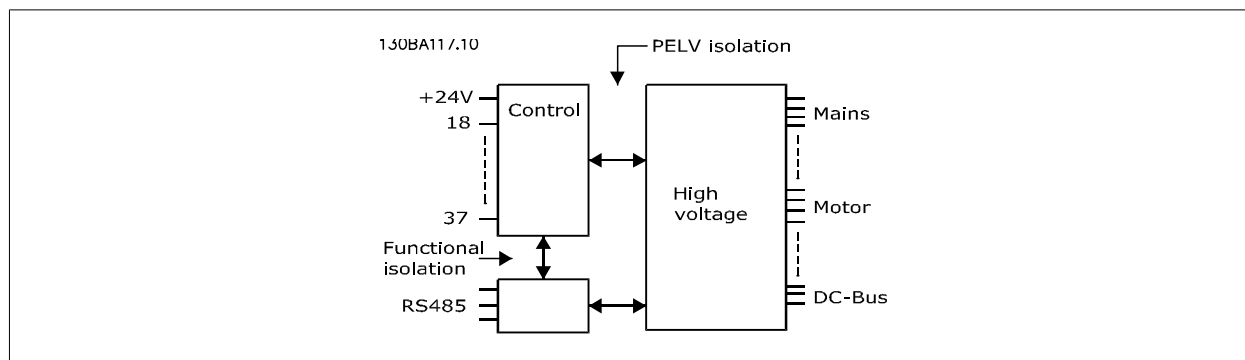

Pulse/encoder inputs:

Programmable pulse/encoder inputs	2/1
Terminal number pulse/encoder	29 ¹⁾ , 33 ²⁾ / 32 ³⁾ , 33 ³⁾
Max. frequency at terminal 29, 32, 33	110 kHz (push-pull driven)
Max. frequency at terminal 29, 32, 33	5 kHz (open collector)
Min. frequency at terminal 29, 32, 33	4 Hz
Voltage level	see section on Digital input
Maximum voltage on input	28 V DC
Input resistance, R _i	approx. 4 kΩ
Pulse input accuracy (0.1–1 kHz)	Max. error: 0.1% of full scale
Encoder input accuracy (1–110 kHz)	Max. error: 0.05% of full scale

The pulse and encoder inputs (terminals 29, 32, 33) are galvanically isolated from the supply voltage (PELV) and other high-voltage terminals.

- 1) FC 302 only
- 2) Pulse inputs are 29 and 33
- 3) Encoder inputs: 32 = A, and 33 = B

Digital output:

Programmable digital/pulse outputs	2
Terminal number	27, 29 ¹⁾
Voltage level at digital/frequency output	0–24 V
Max. output current (sink or source)	40 mA
Max. load at frequency output	1 kΩ
Max. capacitive load at frequency output	10 nF
Minimum output frequency at frequency output	0 Hz
Maximum output frequency at frequency output	32 kHz
Accuracy of frequency output	Max. error: 0.1% of full scale
Resolution of frequency outputs	12 bit

1) Terminal 27 and 29 can also be programmed as input.

The digital output is galvanically isolated from the supply voltage (PELV) and other high-voltage terminals.

Analog output:

Number of programmable analog outputs	1
Terminal number	42
Current range at analog output	0/4–20 mA
Max. load GND - analog output	500 Ω
Accuracy on analog output	Max. error: 0.5% of full scale
Resolution on analog output	12 bit

The analog output is galvanically isolated from the supply voltage (PELV) and other high-voltage terminals.

Control card, 24 V DC output:

Terminal number	12, 13
Output voltage	24 V +1, -3 V
Max. load	200 mA

The 24 V DC supply is galvanically isolated from the supply voltage (PELV), but has the same potential as the analog and digital inputs and outputs.

Control card, 10 V DC output:

Terminal number	50
Output voltage	10.5 V ±0.5 V
Max. load	15 mA

The 10 V DC supply is galvanically isolated from the supply voltage (PELV) and other high-voltage terminals.

Control card, RS-485 serial communication:

Terminal number	68 (P, TX+, RX+), 69 (N, TX-, RX-)
Terminal number 61	Common for terminals 68 and 69

The RS-485 serial communication circuit is functionally separated from other central circuits and galvanically isolated from the supply voltage (PELV).

Control card, USB serial communication:

USB standard	1.1 (Full speed)
USB plug	USB type B "device" plug

Connection to PC is carried out via a standard host/device USB cable.

The USB connection is galvanically isolated from the supply voltage (PELV) and other high-voltage terminals.

The USB ground connection is not galvanically isolated from protection ground. Use only an isolated laptop as PC connection to the USB connector on the adjustable frequency drive.

Relay outputs:

Programmable relay outputs	2
Relay 01 Terminal number	1-3 (break), 1-2 (make)
Max. terminal load (AC-1) ¹⁾ on 1-3 (NC), 1-2 (NO) (Resistive load)	240 V AC, 2 A
Max. terminal load (AC-15) ¹⁾ (Inductive load @ cosφ 0.4)	240 V AC, 0.2 A
Max. terminal load (DC-1) ¹⁾ on 1-2 (NO), 1-3 (NC) (Resistive load)	60 V DC, 1 A
Max. terminal load (DC-13) ¹⁾ (Inductive load)	24 V DC, 0.1 A
Relay 02 (FC 302 only) Terminal number	4-6 (break), 4-5 (make)
Max. terminal load (AC-1) ¹⁾ on 4-5 (NO) (Resistive load)	400 V AC, 2 A
Max. terminal load (AC-15) ¹⁾ on 4-5 (NO) (Inductive load @ cosφ 0.4)	240 V AC, 0.2 A
Max. terminal load (DC-1) ¹⁾ on 4-5 (NO) (Resistive load)	80 V DC, 2 A
Max. terminal load (DC-13) ¹⁾ on 4-5 (NO) (Inductive load)	24 V DC, 0.1 A
Max. terminal load (AC-1) ¹⁾ on 4-6 (NC) (Resistive load)	240 V AC, 2 A
Max. terminal load (AC-15) ¹⁾ on 4-6 (NC) (Inductive load @ cosφ 0.4)	240 V AC, 0.2 A
Max. terminal load (DC-1) ¹⁾ on 4-6 (NC) (Resistive load)	50 V DC, 2 A
Max. terminal load (DC-13) ¹⁾ on 4-6 (NC) (Inductive load)	24 V DC, 0.1 A
Min. terminal load on 1-3 (NC), 1-2 (NO), 4-6 (NC), 4-5 (NO)	24 V DC 10 mA, 24 V AC 20 mA
Environment according to EN 60664-1	overvoltage category III/pollution degree 2

1) IEC 60947 part 4 and 5

The relay contacts are galvanically isolated from the rest of the circuit by reinforced isolation (PELV).

Cable lengths and cross-sections:

Max. motor cable length, shielded/armored	492 ft [150 m]
Max. motor cable length, unshielded/unarmored	984 ft [300 m]
Maximum cross-section to control terminals, flexible/rigid wire without cable end sleeves	0.0023 in ² [1.5 mm ²]/16 AWG
Maximum cross-section to control terminals, flexible wire with cable end sleeves	0.0016 in ² [1 mm ²]/18 AWG
Maximum cross-section to control terminals, flexible wire with cable end sleeves with collar	0.0008 in ² [0.5 mm ²]/20 AWG
Minimum cross-section to control terminals	0.0039 in ² [0.25 mm ²]/24 AWG

Control card performance:

Scan interval	1 ms
Control characteristics:	
Resolution of output frequency at 0–1000 Hz	+/- 0.003 Hz
Repeat accuracy of <i>Precise start/stop</i> (terminals 18, 19)	≤± 0.1 msec
System response time (terminals 18, 19, 27, 29, 32, 33)	≤ 2 ms
Speed control range (open-loop)	1:100 of synchronous speed
Speed control range (closed-loop)	1:1000 of synchronous speed
Speed accuracy (open-loop)	30–4000 rpm: error ±8 rpm
Speed accuracy (closed-loop), depending on resolution of feedback device	0–6000 rpm: error ±0.15 rpm

All control characteristics are based on a 4-pole asynchronous motor

Surroundings:

Enclosure, frame size D and E	IP 00/ Chassis, IP 21/ Type 1, IP 54/ Type 12
Enclosure, frame size F	IP 21/ Type 1, IP 54/ Type 12
Vibration test	0.025 oz [0.7 g]
Max. relative humidity	5%–95% (IEC 721-3-3; Class 3K3 (non-condensing) during operation)
Aggressive environment (IEC 60068-2-43)	class H25
Ambient temperature (with SFAVM switching mode)	
- with derating	Max. 131°F [55°C] ¹⁾
- at full continuous adjustable frequency drive output current	Max. 113°F [45°C] ¹⁾
<i>1) For more information on derating, see special conditions in the Design Guide</i>	
Minimum ambient temperature during full-scale operation	32°F [0°C]
Minimum ambient temperature at reduced performance	14°F [-10°C]
Temperature during storage/transport	-13°–+°149/°158°F [-25°–+65°/70°C]
Maximum altitude above sea level without derating	3280 ft [1000 m]

Derating for high altitude, see special conditions in the Design Guide

EMC standards, Emission	EN 61800-3, EN 61000-6-3/4, EN 55011 EN 61800-3, EN 61000-6-1/2,
EMC standards, Immunity	EN 61000-4-2, EN 61000-4-3, EN 61000-4-4, EN 61000-4-5, EN 61000-4-6

See section on special conditions in the Design Guide .

Protection and Features:

- Electronic thermal motor protection against overload.
- Temperature monitoring of the heatsink ensures that the adjustable frequency drive trips if the temperature reaches a predefined level. An overload temperature cannot be reset until the temperature of the heatsink is below the values stated in the tables on the following pages (guideline - these temperatures may vary for different power sizes, frame sizes, enclosure ratings, etc.).
- The adjustable frequency drive is protected against short-circuits on motor terminals U, V, W.
- If a line phase is missing, the adjustable frequency drive trips or issues a warning (depending on the load).
- Monitoring of the intermediate circuit voltage ensures that the adjustable frequency drive trips if the intermediate circuit voltage is too low or too high.
- The adjustable frequency drive constantly checks for critical levels of internal temperature, load current, high voltage on the intermediate circuit and low motor speeds. As a response to a critical level, the adjustable frequency drive can adjust the switching frequency and/or change the switching pattern in order to ensure the performance of the drive.



5

Line Power Supply 3 x 380–500 VAC

FC 302	P90K		P110		P132		P160		P200	
High/ Normal Load*	HO	NO	HO	NO	HO	NO	HO	NO	HO	NO
Typical Shaft output at 400 V [kW]	90	110	110	132	132	160	160	200	200	250
Typical Shaft output at 460 V [HP]	125	150	150	200	200	250	250	300	300	350
Typical Shaft output at 500 V [kW]	110	132	132	160	160	200	200	250	250	315
Enclosure IP21	D1		D1		D2		D2		D2	
Enclosure IP54	D1		D1		D2		D2		D2	
Enclosure IP00	D3		D3		D4		D4		D4	
Output current										
Continuous (at 400 V) [A]	177	212	212	260	260	315	315	395	395	480
Intermittent (60 sec overload) (at 400 V) [A]	266	233	318	286	390	347	473	435	593	528
Continuous (at 460/ 500 V) [A]	160	190	190	240	240	302	302	361	361	443
Intermittent (60 sec overload) (at 460/ 500 V) [A]	240	209	285	264	360	332	453	397	542	487
Continuous KVA (at 400 V) [KVA]	123	147	147	180	180	218	218	274	274	333
Continuous KVA (at 460 V) [KVA]	127	151	151	191	191	241	241	288	288	353
Continuous KVA (at 500 V) [KVA]	139	165	165	208	208	262	262	313	313	384
Max. input current										
Continuous (at 400 V) [A]	171	204	204	251	251	304	304	381	381	463
Continuous (at 460/ 500 V) [A]	154	183	183	231	231	291	291	348	348	427
Max. cable size, line power motor, brake and load share [mm ² (AWG ²)]	2 x 70 (2 x 2/0)		2 x 70 (2 x 2/0)		2 x 150 (2 x 300 mcm)		2 x 150 (2 x 300 mcm)		2 x 150 (2 x 300 mcm)	
Max. external electrical fuses [A] 1	300		350		400		500		630	
Estimated power loss at 400 V [W] 4)	2641	3234	2995	3782	3425	4213	3910	5119	4625	5893
Estimated power loss at 460 V [W]	2453	2947	2734	3665	3249	4063	3816	4652	4472	5634
Weight, enclosure IP21, IP 54 [kg]	96		104		125		136		151	
Weight, enclosure IP00 [kg]	82		91		112		123		138	
Efficiency ³⁾	0.98									
Output frequency	0–800 Hz									
Heatsink overtemp. trip	185°F [85°C]		194°F [90°C]		221°F [105°C]		221°F [105°C]		239°F [115°C]	
Power card ambient trip	140°F [60°C]									

* High overload = 160% torque during 60 s, Normal overload = 110% torque during 60 s

Line Power Supply 3 x 380–500 V AC										
FC 302		P250		P315		P355		P400		
High/ Normal Load*		HO	NO	HO	NO	HO	NO	HO	NO	
	Typical Shaft output at 400 V [kW]	250	315	315	355	355	400	400	450	
	Typical Shaft output at 460 V [HP]	350	450	450	500	500	600	550	600	
	Typical Shaft output at 500 V [kW]	315	355	355	400	400	500	500	530	
	Enclosure IP21	E1		E1		E1		E1		
	Enclosure IP54	E1		E1		E1		E1		
	Enclosure IP00	E2		E2		E2		E2		
	Output current									
	Continuous (at 400 V) [A]	480	600	600	658	658	745	695	800	
	Intermittent (60 sec over-load) (at 400 V) [A]	720	660	900	724	987	820	1043	880	
	Continuous (at 460/ 500 V) [A]	443	540	540	590	590	678	678	730	
Intermittent (60 sec over-load) (at 460/ 500 V) [A]	665	594	810	649	885	746	1017	803		
Continuous KVA (at 400 V) [KVA]	333	416	416	456	456	516	482	554		
Continuous KVA (at 460 V) [KVA]	353	430	430	470	470	540	540	582		
Continuous KVA (at 500 V) [KVA]	384	468	468	511	511	587	587	632		
Max. input current										
	Continuous (at 400 V) [A]	472	590	590	647	647	733	684	787	
	Continuous (at 460/ 500 V) [A]	436	531	531	580	580	667	667	718	
	Max. cable size, line power, motor and load share [mm ² (AWG ²)]	4x240 (4x500 mcm)		4x240 (4x500 mcm)		4x240 (4x500 mcm)		4x240 (4x500 mcm)		
	Max. cable size, brake [mm ² (AWG ²)]	2 x 185 (2 x 350 mcm)		2 x 185 (2 x 350 mcm)		2 x 185 (2 x 350 mcm)		2 x 185 (2 x 350 mcm)		
	Max. external electrical fuses [A] 1	700		900		900		900		
	Estimated power loss at 400 V [W] ⁴⁾	5164	6790	6960	7701	7691	8879	8178	9670	
	Estimated power loss at 460 V [W]	4822	6082	6345	6953	6944	8089	8085	8803	
	Weight, enclosure IP21, IP 54 [kg]	263		270		272		313		
	Weight, enclosure IP00 [kg]	221		234		236		277		
	Efficiency ⁴⁾	0.98								
Output frequency	0–600 Hz									
Heatsink overtemp. trip	203°F [95°C]									
Power card ambient trip	154°F [68°C]									

* High overload = 160% torque during 60 s, Normal overload = 110% torque during 60 s

5

Line Power Supply 3 x 380–500 V AC														
FC 302		P450		P500		P560		P630		P710		P800		
High/ Normal Load*		HO	NO	HO	NO	HO	NO	HO	NO	HO	NO	HO	NO	
	Typical Shaft output at 400 V [kW]	450	500	500	560	560	630	630	710	710	800	800	1000	
	Typical Shaft output at 460 V [HP]	600	650	650	750	750	900	900	1000	1000	1200	1200	1350	
	Typical Shaft output at 500 V [kW]	530	560	560	630	630	710	710	800	800	1000	1000	1100	
	Enclosure IP21, 54 without/ with options cabinet	F1/ F3		F1/ F3		F1/ F3		F1/ F3		F2/ F4		F2/ F4		
Output current														
	Continuous (at 400 V) [A]	800	880	880	990	990	1120	1120	1260	1260	1460	1460	1720	
	Intermittent (60 sec overload) (at 400 V) [A]	1200	968	1320	1089	1485	1232	1680	1386	1890	1606	2190	1892	
	Continuous (at 460/ 500 V) [A]	730	780	780	890	890	1050	1050	1160	1160	1380	1380	1530	
	Intermittent (60 sec overload) (at 460/ 500 V) [A]	1095	858	1170	979	1335	1155	1575	1276	1740	1518	2070	1683	
	Continuous KVA (at 400 V) [KVA]	554	610	610	686	686	776	776	873	873	1012	1012	1192	
	Continuous KVA (at 460 V) [KVA]	582	621	621	709	709	837	837	924	924	1100	1100	1219	
	Continuous KVA (at 500 V) [KVA]	632	675	675	771	771	909	909	1005	1005	1195	1195	1325	
	Max. input current													
		Continuous (at 400 V) [A]	779	857	857	964	964	1090	1090	1227	1227	1422	1422	1675
		Continuous (at 460/ 500 V) [A]	711	759	759	867	867	1022	1022	1129	1129	1344	1344	1490
Max. cable size, motor [mm ² (AWG ²)]		8x150 (8x300 mcm)						12x150 (12x300 mcm)						
Max. cable size, line power F1/F2 [mm ² (AWG ²)]		8x240 (8x500 mcm)												
Max. cable size, line power F3/F4 [mm ² (AWG ²)]		8x456 (8x900 mcm)												
Max. cable size, load-sharing [mm ² (AWG ²)]		4x120 (4x250 mcm)												
Max. cable size, brake [mm ² (AWG ²)]		4x185 (4x350 mcm)						6x185 (6x350 mcm)						
Max. external electrical fuses [A] 1		1600				2000				2500				
Estimated power loss at 400 V [W] ⁴⁾		9492	10647	10631	12338	11263	13201	13172	15436	14967	18084	16392	20358	
Estimated power loss at 460 V [W]		8730	9414	9398	11006	10063	12353	12332	14041	13819	17137	15577	17752	
F3/F4 max. added losses A1 RFI, CB or Disconnect, & Contactor F3 & F4	893	963	951	1054	978	1093	1092	1230	2067	2280	2236	2541		
Max. panel options losses	400													
Weight, enclosure IP21, IP 54 [kg]	1004/ 1299		1004/ 1299		1004/ 1299		1004/ 1299		1246/ 1541		1246/ 1541			
Weight Rectifier Module [kg]	102		102		102		102		136		136			
Weight Inverter Module [kg]	102		102		102		136		102		102			
Efficiency ⁴⁾	0.98													
Output frequency	0–600 Hz													
Heatsink overtemp. trip	203°F [95°C]													
Power card ambient trip	154°F [68°C]													
* High overload = 160% torque during 60 s, Normal overload = 110% torque during 60 s														

Line Power Supply 3 x 525–690 V AC												
FC 302		P37K		P45K		P55K		P75K		P90K		
High/ Normal Load*		HO	NO	HO	NO	HO	NO	HO	NO	HO	NO	
Typical Shaft output at 550 V [kW]		30	37	37	45	45	55	55	75	75	90	
Typical Shaft output at 575 V [HP]		40	50	50	60	60	75	75	100	100	125	
Typical Shaft output at 690 V [kW]		37	45	45	55	55	75	75	90	90	110	
Enclosure IP21		D1		D1		D1		D1		D1		
Enclosure IP54		D1		D1		D1		D1		D1		
Enclosure IP00		D3		D3		D3		D3		D3		
Output current												
	Continuous (at 550 V) [A]	48	56	56	76	76	90	90	113	113	137	
	Intermittent (60 sec overload) (at 550 V) [A]	77	62	90	84	122	99	135	124	170	151	
	Continuous (at 575/690 V) [A]	46	54	54	73	73	86	86	108	108	131	
	Intermittent (60 sec overload) (at 575/690 V) [A]	74	59	86	80	117	95	129	119	162	144	
	Continuous KVA (at 550 V) [KVA]	46	53	53	72	72	86	86	108	108	131	
	Continuous KVA (at 575 V) [KVA]	46	54	54	73	73	86	86	108	108	130	
	Continuous KVA (at 690 V) [KVA]	55	65	65	87	87	103	103	129	129	157	
	Max. input current											
		Continuous (at 550 V) [A]	53	60	60	77	77	89	89	110	110	130
		Continuous (at 575 V) [A]	51	58	58	74	74	85	85	106	106	124
Continuous (at 690 V) [A]		50	58	58	77	77	87	87	109	109	128	
Max. cable size, line power, motor, load share and brake [mm ² (AWG)]		2x70 (2x2/0)										
Max. external electrical fuses [A] 1		125		160		200		200		250		
Estimated power loss at 600 V [W] ⁴⁾		1299	1398	1459	1645	1643	1827	1827	2156	2158	2532	
Estimated power loss at 690 V [W] ⁴⁾		1355	1458	1459	1717	1721	1913	1913	2262	2264	2662	
Weight, enclosure IP21, IP 54 [kg]		96										
Weight, enclosure IP00 [kg]		82										
Efficiency ⁴⁾		0.97		0.97		0.98		0.98		0.98		
Output frequency		0–600 Hz										
Heatsink overtemp. trip		185°F [85°C]										
Power card ambient trip		140°F [60°C]										
* High overload = 160% torque during 60 s, Normal overload = 110% torque during 60 s												

5

Line Power Supply 3 x 525–690 V AC		P110		P132		P160		P200		
FC 302		HO	NO	HO	NO	HO	NO	HO	NO	
High/ Normal Load*										
	Typical Shaft output at 550 V [kW]	90	110	110	132	132	160	160	200	
	Typical Shaft output at 575 V [HP]	125	150	150	200	200	250	250	300	
	Typical Shaft output at 690 V [kW]	110	132	132	160	160	200	200	250	
	Enclosure IP21	D1		D1		D2		D2		
	Enclosure IP54	D1		D1		D2		D2		
	Enclosure IP00	D3		D3		D4		D4		
Output current										
	Continuous (at 550 V) [A]	137	162	162	201	201	253	253	303	
	Intermittent (60 sec over-load) (at 550 V) [A]	206	178	243	221	302	278	380	333	
	Continuous (at 575/690 V) [A]	131	155	155	192	192	242	242	290	
	Intermittent (60 sec over-load) (at 575/690 V) [A]	197	171	233	211	288	266	363	319	
	Continuous KVA (at 550 V) [KVA]	131	154	154	191	191	241	241	289	
	Continuous KVA (at 575 V) [KVA]	130	154	154	191	191	241	241	289	
	Continuous KVA (at 690 V) [KVA]	157	185	185	229	229	289	289	347	
	Max. input current									
		Continuous (at 550 V) [A]	130	158	158	198	198	245	245	299
		Continuous (at 575 V) [A]	124	151	151	189	189	234	234	286
Continuous (at 690 V) [A]		128	155	155	197	197	240	240	296	
Max. cable size, line power motor, load share and brake [mm ² (AWG)]		2 x 70 (2 x 2/0)		2 x 70 (2 x 2/0)		2 x 150 (2 x 300 mcm)		2 x 150 (2 x 300 mcm)		
Max. external electrical fuses [A] 1		315		350		350		400		
Estimated power loss at 600 V [W] ⁴⁾		2536	2963	2806	3430	3261	4051	4037	4867	
Estimated power loss at 690 V [W] ⁴⁾		2664	3114	2953	3612	3451	4292	4275	5156	
Weight, Enclosure IP21, IP 54 [kg]		96		104		125		136		
Weight, Enclosure IP00 [kg]		82		91		112		123		
Efficiency ⁴⁾		0.98								
Output frequency	0–600 Hz									
Heatsink overtemp. trip	185°F [85°C]		194°F [90°C]		230°F [110°C]		230°F [110°C]			
Power card ambient trip	140°F [60°C]									
* High overload = 160% torque during 60 s, Normal overload = 110% torque during 60 s										

Line Power Supply 3 x 525–690 V AC								
FC 302		P250		P315		P355		
High/ Normal Load*		HO	NO	HO	NO	HO	NO	
	Typical Shaft output at 550 V [kW]	200	250	250	315	315	355	
	Typical Shaft output at 575 V [HP]	300	350	350	400	400	450	
	Typical Shaft output at 690 V [kW]	250	315	315	400	355	450	
	Enclosure IP21	D2		D2		E1		
	Enclosure IP54	D2		D2		E1		
	Enclosure IP00	D4		D4		E2		
Output current								
	Continuous (at 550 V) [A]	303	360	360	418	395	470	
	Intermittent (60 sec overload) (at 550 V) [A]	455	396	540	460	593	517	
	Continuous (at 575/690 V) [A]	290	344	344	400	380	450	
	Intermittent (60 sec overload) (at 575/690 V) [A]	435	378	516	440	570	495	
	Continuous KVA (at 550 V) [KVA]	289	343	343	398	376	448	
	Continuous KVA (at 575 V) [KVA]	289	343	343	398	378	448	
	Continuous KVA (at 690 V) [KVA]	347	411	411	478	454	538	
	Max. input current							
		Continuous (at 550 V) [A]	299	355	355	408	381	453
		Continuous (at 575 V) [A]	286	339	339	390	366	434
Continuous (at 690 V) [A]		296	352	352	400	366	434	
Max. cable size, line power, motor and load share [mm ² (AWG)]		2 x 150 (2 x 300 mcm)		2 x 150 (2 x 300 mcm)		4 x 240 (4 x 500 mcm)		
Max. cable size, brake [mm ² (AWG)]		2 x 150 (2 x 300 mcm)		2 x 150 (2 x 300 mcm)		2 x 185 (2 x 350 mcm)		
Max. external electrical fuses [A] 1		500		550		700		
Estimated power loss at 600 V [W] 4)		4601	5493	4938	5852	5107	6132	
Estimated power loss at 690 V [W] 4)		4875	5821	5185	6149	5383	6449	
Weight, enclosure IP21, IP 54 [kg]		151		165		263		
Weight, enclosure IP00 [kg]		138		151		221		
Efficiency ³⁾	0.98							
Output frequency	0–600 Hz		0–500 Hz		0–500 Hz			
Heatsink overtemp. trip	230°F [110°C]		230°F [110°C]		185°F [85°C]			
Power card ambient trip	140°F [60°C]		140°F [60°C]		154°F [68°C]			

* High overload = 160% torque during 60 s, Normal overload = 110% torque during 60 s

5

Line Power Supply 3 x 525–690 V AC		P400		P500		P560		
FC 302		HO	NO	HO	NO	HO	NO	
High/ Normal Load*								
	Typical Shaft output at 550 V [kW]	315	400	400	450	450	500	
	Typical Shaft output at 575 V [HP]	400	500	500	600	600	650	
	Typical Shaft output at 690 V [kW]	400	500	500	560	560	630	
	Enclosure IP21	E1		E1		E1		
	Enclosure IP54	E1		E1		E1		
	Enclosure IP00	E2		E2		E2		
Output current								
	Continuous (at 550 V) [A]	429	523	523	596	596	630	
	Intermittent (60 sec overload) (at 550 V) [A]	644	575	785	656	894	693	
	Continuous (at 575/690 V) [A]	410	500	500	570	570	630	
	Intermittent (60 sec overload) (at 575/690 V) [A]	615	550	750	627	855	693	
	Continuous KVA (at 550 V) [KVA]	409	498	498	568	568	600	
	Continuous KVA (at 575 V) [KVA]	408	498	498	568	568	627	
	Continuous KVA (at 690 V) [KVA]	490	598	598	681	681	753	
	Max. input current							
		Continuous (at 550 V) [A]	413	504	504	574	574	607
		Continuous (at 575 V) [A]	395	482	482	549	549	607
Continuous (at 690 V) [A]		395	482	482	549	549	607	
	Max. cable size, line power, motor and load share [mm ² (AWG)]	4x240 (4x500 mcm)		4x240 (4x500 mcm)		4x240 (4x500 mcm)		
	Max. cable size, brake [mm ² (AWG)]	2 x 185 (2 x 350 mcm)		2 x 185 (2 x 350 mcm)		2 x 185 (2 x 350 mcm)		
	Max. external electrical fuses [A] 1	700		900		900		
	Estimated power loss at 600 V [W] ⁴⁾	5538	6903	7336	8343	8331	9244	
	Estimated power loss at 690 V [W] ⁴⁾	5818	7249	7671	8727	8715	9673	
	Weight, enclosure IP21, IP 54 [kg]	263		272		313		
	Weight, enclosure IP00 [kg]	221		236		277		
	Efficiency ⁴⁾	0.98						
	Output frequency	0–500 Hz						
	Heatsink overtemp. trip	185°F [85°C]						
	Power card ambient trip	154°F [68°C]						

* High overload = 160% torque during 60 s, Normal overload = 110% torque during 60 s

Line Power Supply 3 x 525–690 V AC								
FC 302		P630		P710		P800		
High/ Normal Load*		HO	NO	HO	NO	HO	NO	
	Typical Shaft output at 550 V [kW]	500	560	560	670	670	750	
	Typical Shaft output at 575 V [HP]	650	750	750	950	950	1050	
	Typical Shaft output at 690 V [kW]	630	710	710	800	800	900	
	Enclosure IP21, 54 without/with options cabinet	F1/ F3		F1/ F3		F1/ F3		
	Output current							
	Continuous (at 550 V) [A]	659	763	763	889	889	988	
	Intermittent (60 sec overload) (at 550 V) [A]	989	839	1145	978	1334	1087	
	Continuous (at 575/690 V) [A]	630	730	730	850	850	945	
	Intermittent (60 sec overload) (at 575/690 V) [A]	945	803	1095	935	1275	1040	
	Continuous KVA (at 550 V) [KVA]	628	727	727	847	847	941	
Continuous KVA (at 575 V) [KVA]	627	727	727	847	847	941		
Continuous KVA (at 690 V) [KVA]	753	872	872	1016	1016	1129		
Max. input current								
	Continuous (at 550 V) [A]	642	743	743	866	866	962	
	Continuous (at 575 V) [A]	613	711	711	828	828	920	
	Continuous (at 690 V) [A]	613	711	711	828	828	920	
	Max. cable size, motor [mm ² (AWG ²)]	8x150 (8x300 mcm)						
	Max. cable size, line power F1 [mm ² (AWG ²)]	8x240 (8x500 mcm)						
	Max. cable size, line power F3 [mm ² (AWG ²)]	8x456 (8x900 mcm)						
	Max. cable size, loadsharing [mm ² (AWG ²)]	4x120 (4x250 mcm)						
	Max. cable size, brake [mm ² (AWG ²)]	4x185 (4x350 mcm)						
	Max. external electrical fuses [A] 1	1600						
	Estimated power loss at 600 V [W] ⁴⁾	9201	10771	10416	12272	12260	13835	
	Estimated power loss at 690V [W] ⁴⁾	9674	11315	10965	12903	12890	14533	
	F3/F4 Max added losses CB or Disconnect & Contactor	342	427	419	532	519	615	
	Max panel options losses	400						
	Weight, enclosure IP21, IP 54 [kg]	1004/ 1299		1004/ 1299		1004/ 1299		
	Weight, Rectifier Module [kg]	102		102		102		
Weight, Inverter Module [kg]	102		102		136			
Efficiency ³⁾	0.98							
Output frequency	0–500 Hz							
Heatsink overtemp. trip	185°F [85°C]							
Power card ambient trip	154°F [68°C]							

* High overload = 160% torque during 60 s, Normal overload = 110% torque during 60 s

5

Line Power Supply 3 x 525–690 V AC		P900		P1M0		P1M2		
FC 302		HO	NO	HO	NO	HO	NO	
High/ Normal Load*								
	Typical Shaft output at 550 V [kW]	750	850	850	1000	1000	1100	
	Typical Shaft output at 575 V [HP]	1050	1150	1150	1350	1350	1550	
	Typical Shaft output at 690 V [kW]	900	1000	1000	1200	1200	1400	
	Enclosure IP21, 54 without/with options cabinet	F2/ F4		F2/ F4		F2/ F4		
	Output current							
	Continuous (at 550 V) [A]	988	1108	1108	1317	1317	1479	
	Intermittent (60 sec overload) (at 550 V) [A]	1482	1219	1662	1449	1976	1627	
	Continuous (at 575/690 V) [A]	945	1060	1060	1260	1260	1415	
	Intermittent (60 sec overload) (at 575/690 V) [A]	1418	1166	1590	1386	1890	1557	
	Continuous KVA (at 550 V) [KVA]	941	1056	1056	1255	1255	1409	
Continuous KVA (at 575 V) [KVA]	941	1056	1056	1255	1255	1409		
Continuous KVA (at 690 V) [KVA]	1129	1267	1267	1506	1506	1691		
Max. input current								
	Continuous (at 550 V) [A]	962	1079	1079	1282	1282	1440	
	Continuous (at 575 V) [A]	920	1032	1032	1227	1227	1378	
	Continuous (at 690 V) [A]	920	1032	1032	1227	1227	1378	
	Max. cable size, motor [mm ² (AWG ²)]	12x150 (12x300 mcm)						
	Max. cable size, line power F2 [mm ² (AWG ²)]	8x240 (8x500 mcm)						
	Max. cable size, line power F4 [mm ² (AWG ²)]	8x456 (8x900 mcm)						
	Max. cable size, loadsharing [mm ² (AWG ²)]	4x120 (4x250 mcm)						
	Max. cable size, brake [mm ² (AWG ²)]	6x185 (6x350 mcm)						
	Max. external electrical fuses [A]	1600		2000		2500		
	Estimated power loss at 600 V [W] ⁴⁾	13755	15592	15107	18281	18181	20825	
Estimated power loss at 690V [W] ⁴⁾	14457	16375	15899	19207	19105	21857		
F3/F4 Max added losses CB or Disconnect & Contactor	556	665	634	863	861	1044		
Max panel options losses	400							
Weight, enclosure IP21, IP 54 [kg]	1246/ 1541		1246/ 1541		1280/1575			
Weight, Rectifier Module [kg]	136		136		136			
Weight, Inverter Module [kg]	102		102		136			
Efficiency ⁴⁾	0.98							
Output frequency	0–500 Hz							
Heatsink overtemp. trip	185°F [85°C]							
Power card ambient trip	154°F [68°C]							

* High overload = 160% torque during 60 s, Normal overload = 110% torque during 60 s

- 1) For type of fuse, see the section Fuses.
 - 2) American Wire Gauge.
 - 3) Measured using 16.4 ft [5 m] shielded motor cables at rated load and rated frequency.
 - 4) The typical power loss is at nominal load conditions and expected to be within +/-15% (tolerance relates to variety in voltage and cable conditions).
- Values are based on a typical motor efficiency (eff2/eff3 border line). Motors with lower efficiency will also add to the power loss in the adjustable frequency drive and opposite.
- If the switching frequency is increased compared to the default setting, the power losses may rise significantly.
- LCP and typical control card power consumptions are included. Further options and customer load may add up to 30 W to the losses. (Though typical, only 4 W extra for a fully loaded control card, or options for slot A or slot B, each.)
- Although measurements are made with state of the art equipment, some measurement inaccuracy must be allowed for (+/-5%).

6 Warnings and Alarms

6.1 Status Messages

6.1.1 Warnings/Alarm Messages

A warning or an alarm is signaled by the relevant LED on the front of the adjustable frequency drive and indicated by a code on the display.

A warning remains active until its cause is no longer present. Under certain circumstances operation of the motor may still be continued. Warning messages may be critical, but are not necessarily so.

In the event of an alarm, the adjustable frequency drive will have tripped. Alarms must be reset to restart operation once their cause has been rectified.

This may be done in three ways:

1. By using the [RESET] control button on the LCP control panel.
2. Via a digital input with the "Reset" function.
3. Via serial communication/optional serial communication bus.



NOTE!

After a manual reset using the [RESET] button on the LCP, the [AUTO ON] button must be pressed to restart the motor.

If an alarm cannot be reset, the reason may be that its cause has not been rectified, or the alarm is trip-locked (see also table on following page).

Alarms that are trip-locked offer additional protection, meaning that the line power supply must be switched off before the alarm can be reset. After being switched back on, the adjustable frequency drive is no longer blocked and may be reset as described above, once the cause has been rectified.

Alarms that are not trip-locked can also be reset using the automatic reset function in par. 14-20 *Reset Mode* (Warning: automatic wake-up is possible!)

If a warning and alarm are marked against a code in the table on the following page, this means that either a warning occurs before an alarm, or that you can specify whether it is a warning or an alarm that is to be displayed for a given fault.

This is possible, for instance, in par. 1-90 *Motor Thermal Protection*. After an alarm or trip, the motor carries on coasting, and the alarm and warning flash. Once the problem has been rectified, only the alarm continues flashing until the adjustable frequency drive is reset.

No.	Description	Warning	Alarm/Trip	Alarm/Trip Lock	Parameter Reference
1	10 Volts low	X			
2	Live zero error	(X)	(X)		Par. 6-01 <i>Live Zero Time-out Function</i>
3	No motor	(X)			Par. 1-80 <i>Function at Stop</i>
4	Line phase loss	(X)	(X)	(X)	Par. 14-12 <i>Function at Mains Imbalance</i>
5	DC link voltage high	X			
6	DC link voltage low	X			
7	DC overvoltage	X	X		
8	DC undervoltage	X	X		
9	Inverter overloaded	X	X		
10	Motor ETR overtemperature	(X)	(X)		Par. 1-90 <i>Motor Thermal Protection</i>
11	Motor thermistor overtemperature	(X)	(X)		Par. 1-90 <i>Motor Thermal Protection</i>
12	Torque limit	X	X		
13	Overcurrent	X	X	X	
14	Ground Fault	X	X	X	
15	Hardware mismatch		X	X	
16	Short Circuit		X	X	
17	Control word timeout	(X)	(X)		Par. 8-04 <i>Control Word Timeout Function</i>
22	Hoist Mech. Brake				
23	Internal Fan Fault	X			
24	External Fan Fault	X			Par. 14-53 <i>Fan Monitor</i>
25	Brake resistor short-circuited	X			
26	Brake resistor power limit	(X)	(X)		Par. 2-13 <i>Brake Power Monitoring</i>
27	Brake chopper short-circuited	X	X		
28	Brake check	(X)	(X)		Par. 2-15 <i>Brake Check</i>
29	Heatsink temp	X	X	X	
30	Motor phase U missing	(X)	(X)	(X)	Par. 4-58 <i>Missing Motor Phase Function</i>
31	Motor phase V missing	(X)	(X)	(X)	Par. 4-58 <i>Missing Motor Phase Function</i>
32	Motor phase W missing	(X)	(X)	(X)	Par. 4-58 <i>Missing Motor Phase Function</i>
33	Soft-charge Fault		X	X	
34	Serial Communication Bus communication fault	X	X		
36	Line failure	X	X		
37	Phase imbalance		X		
38	Internal Fault		X	X	
39	Heatsink sensor		X	X	
40	Overload of Digital Output Terminal 27	(X)			Par. 5-00 <i>Digital I/O Mode</i> , par. 5-01 <i>Terminal 27 Mode</i>
41	Overload of Digital Output Terminal 29	(X)			Par. 5-00 <i>Digital I/O Mode</i> , par. 5-02 <i>Terminal 29 Mode</i>
42	Overload of Digital Output On X30/6	(X)			Par. 5-32 <i>Term X30/6 Digi Out (MCB 101)</i>
42	Overload of Digital Output On X30/7	(X)			Par. 5-33 <i>Term X30/7 Digi Out (MCB 101)</i>
46	Pwr. card supply		X	X	
47	24 V supply low	X	X	X	
48	1.8 V supply low		X	X	
49	Speed limit	X			
50	AMA calibration failed		X		
51	AMA check U_{nom} and I_{nom}		X		
52	AMA low I_{nom}		X		
53	AMA motor too big		X		

Table 6.1: Alarm/Warning code list

No.	Description	Warning	Alarm/Trip	Alarm/Trip Lock	Parameter Reference
54	AMA motor too small		X		
55	AMA parameter out of range		X		
56	AMA interrupted by user		X		
57	AMA timeout		X		
58	AMA internal fault	X	X		
59	Current limit	X			
60	External Interlock	X			
61	Tracking Error	(X)	(X)		Par. 4-30 <i>Motor Feed-back Loss Function</i>
62	Output Frequency at Maximum Limit	X			
63	Mechanical Brake Low		(X)		Par. 2-20 <i>Release Brake Current</i>
64	Voltage Limit	X			
65	Control Board Overtemperature	X	X	X	
66	Heatsink Temperature Low	X			
67	Option Configuration has Changed		X		
68	Safe Stop	(X)	(X) ¹⁾		Par. 5-19 <i>Terminal 37 Safe Stop</i>
69	Pwr. Card Temp		X	X	
70	Illegal FC configuration			X	
71	PTC 1 Safe Stop	X	X ¹⁾		Par. 5-19 <i>Terminal 37 Safe Stop</i>
72	Dangerous Failure			X ¹⁾	Par. 5-19 <i>Terminal 37 Safe Stop</i>
73	Safe Stop Auto Restart				
76	Power Unit Set-up	X			
77	Reduced power mode	X			Par. 14-59 <i>Actual Number of Inverter Units</i>
78	Tracking Error				
79	Illegal PS config		X	X	
80	Drive Initialized to Default Value		X		
81	CSIV corrupt				
82	CSIV param error				
85	Profibus/Profisafe Error				
90	Encoder Loss	(X)	(X)		Par. 17-61 <i>Feedback Signal Monitoring S202</i>
91	Analog input 54 wrong settings			X	
100-199	See Instruction Manual for MCO 305				
243	Brake IGBT	X	X		
244	Heatsink temp	X	X	X	
245	Heatsink sensor		X	X	
246	Pwr.card supply		X	X	
247	Pwr.card temp		X	X	
248	Illegal PS config		X	X	
250	New spare part			X	Par. 14-23 <i>Typecode Setting</i>
251	New Type Code		X	X	

Table 6.2: Alarm/Warning code list

(X) Dependent on parameter

1) Cannot be auto reset via par. 14-20 *Reset Mode*

A trip is the action when an alarm has appeared. The trip will coast the motor and can be reset by pressing the reset button or make a reset by a digital input (Par. 5-1* [1]). The original event that caused an alarm cannot damage the adjustable frequency drive or cause dangerous conditions. A trip lock is an action that occurs in conjunction with an alarm, which may cause damage to the adjustable frequency drive or connected parts. A trip lock situation can only be reset by power cycling.

<i>LED indication</i>	
Warning	yellow
Alarm	flashing red
Trip locked	yellow and red

Alarm Word Extended Status Word							
Bit	Hex	Dec	Alarm Word	Alarm Word 2	Warning Word	Warning Word 2	Extended Status Word
0	00000001	1	Brake Check (A28)	ServiceTrip, Read/Write	Brake Check (W28)		Ramping
1	00000002	2	Pwr. Card Temp (A69)	ServiceTrip, (reserved)	Pwr. Card Temp (W69)		AMA Running
2	00000004	4	Ground Fault (A14)	ServiceTrip, Type-code/Sparepart	Ground Fault (W14)		Start CW/CCW
3	00000008	8	Ctrl.Card Temp (A65)	ServiceTrip, (reserved)	Ctrl.Card Temp (W65)		Slow Down
4	00000010	16	Ctrl. Word TO (A17)	ServiceTrip, (reserved)	Ctrl. Word TO (W17)		Catch Up
5	00000020	32	Overcurrent (A13)		Overcurrent (W13)		Feedback High
6	00000040	64	Torque Limit (A12)		Torque Limit (W12)		Feedback Low
7	00000080	128	Motor Th Over (A11)		Motor Th Over (W11)		Output Current High
8	00000100	256	Motor ETR Over (A10)		Motor ETR Over (W10)		Output Current Low
9	00000200	512	Inverter Overld. (A9)		Inverter Overld (W9)		Output Freq High
10	00000400	1024	DC undervolt (A8)		DC undervolt (W8)		Output Freq Low
11	00000800	2048	DC overvolt (A7)		DC overvolt (W7)		Brake Check OK
12	00001000	4096	Short Circuit (A16)		DC Voltage Low (W6)		Braking Max
13	00002000	8192	Soft-charge Fault (A33)		DC Voltage High (W5)		Braking
14	00004000	16384	Line ph. Loss (A4)		Line ph. Loss (W4)		Out of Speed Range
15	00008000	32768	AMA Not OK		No Motor (W3)		OVC Active
16	00010000	65536	Live Zero Error (A2)		Live Zero Error (W2)		AC Brake
17	00020000	131072	Internal Fault (A38)	KTY error	10 V Low (W1)	KTY Warn	Password Timelock
18	00040000	262144	Brake Overload (A26)	Fans error	Brake Overload (W26)	Fans Warn	Password Protection
19	00080000	524288	U phase Loss (A30)	ECB error	Brake Resistor (W25)	ECB Warn	
20	00100000	1048576	V phase Loss (A31)		Brake IGBT (W27)		
21	00200000	2097152	W phase Loss (A32)		Speed Limit (W49)		
22	00400000	4194304	Serial Communication Bus Fault (A34)		Serial Communication Bus Fault (W34)		Unused
23	00800000	8388608	24 V Supply Low (A47)		24V Supply Low (W47)		Unused
24	01000000	16777216	Line Failure (A36)		Line Failure (W36)		Unused
25	02000000	33554432	1.8V Supply Low (A48)		Current Limit (W59)		Unused
26	04000000	67108864	Brake Resistor (A25)		Low Temp (W66)		Unused
27	08000000	134217728	Brake IGBT (A27)		Voltage Limit (W64)		Unused
28	10000000	268435456	Option Change (A67)		Encoder loss (W90)		Unused
29	20000000	536870912	Drive Initialized(A80)		Output freq. lim. (W62)		Unused
30	40000000	1073741824	Safe Stop (A68)	PTC 1 Safe Stop (A71)	Safe Stop (W68)	PTC 1 Safe Stop (W71)	Unused
31	80000000	2147483648	Mech. brake low (A63)	Dangerous Failure (A72)	Extended Status Word		Unused

Table 6.3: Description of Alarm Word, Warning Word and Extended Status Word

The alarm words, warning words and extended status words can be read out via serial bus or optional serial communication bus for diagnosis. See also par. 16-94 *Ext. Status Word*.

WARNING 1, 10 volts low

The control card voltage is below 10 V from terminal 50.

Remove some of the load from terminal 50, as the 10 V supply is overloaded. Max. 15 mA or minimum 590 Ω.

This condition can be caused by a short in a connected potentiometer or improper wiring of the potentiometer.

Troubleshooting: Remove the wiring from terminal 50. If the warning clears, the problem is with the customer wiring. If the warning does not clear, replace the control card.

WARNING/ALARM 2, Live zero error

This warning or alarm will only appear if programmed by the user in parameter 6-01, Live Zero Timeout Function. The signal on one of the analog inputs is less than 50% of the minimum value programmed for that input. This condition can be caused by broken wiring or faulty device sending the signal.

Troubleshooting:

Check connections on all the analog input terminals. Control card terminals 53 and 54 for signals, terminal 55 common. MCB 101 terminals 11 and 12 for signals, terminal 10 common. MCB 109 terminals 1, 3, 5 for signals, terminals 2, 4, 6 common).

Make sure that the drive programming and switch settings match the analog signal type.

Perform Input Terminal Signal Test.

WARNING/ALARM 3, No motor

No motor has been connected to the output of the adjustable frequency drive. This warning or alarm will only appear if programmed by the user in parameter 1-80, Function at Stop.

Troubleshooting: Check the connection between the drive and the motor.

WARNING/ALARM 4, Mains phase loss

A phase is missing on the supply side, or the AC line voltage imbalance is too high. This message also appears for a fault in the input rectifier on the adjustable frequency drive. Options are programmed at parameter 14-12, Function at Mains Imbalance

Troubleshooting: Check the supply voltage and supply currents to the adjustable frequency drive.

WARNING 5, DC link voltage high

The intermediate circuit voltage (DC) is higher than the high voltage warning limit. The limit is dependent on the drive voltage rating. The adjustable frequency drive is still active.

WARNING 6, DC link voltage low

The intermediate circuit voltage (DC) is lower than the low voltage warning limit. The limit is dependent on the drive voltage rating. The adjustable frequency drive is still active.

WARNING/ALARM 7, DC overvoltage

If the intermediate circuit voltage exceeds the limit, the adjustable frequency drive trips after a time.

Troubleshooting:

- Connect a brake resistor
- Extend the ramp time
- Change the ramp type
- Activate functions in par. 2-10 *Brake Function*
- Increase par. 14-26 *Trip Delay at Inverter Fault*

WARNING/ALARM 8, DC undervoltage

If the intermediate circuit voltage (DC) drops below the undervoltage limit, the adjustable frequency drive checks if a 24 V backup supply is connected. If no 24 V backup supply is connected, the adjustable frequency drive trips after a fixed time delay. The time delay varies with unit size.

Troubleshooting:

- Make sure that the supply voltage matches the adjustable frequency drive voltage.
- Perform Input voltage test
- Perform soft charge and rectifier circuit test

WARNING/ALARM 9, Inverter overloaded

The adjustable frequency drive is about to cut out because of an overload (too high current for too long). The counter for electronic, thermal inverter protection gives a warning at 98% and trips at 100%, while giving an alarm. The adjustable frequency drive *cannot* be reset until the counter is below 90%.

The fault is that the adjustable frequency drive is overloaded by more than 100% for too long.

Troubleshooting:

Compare the output current shown on the LCP keypad with the drive rated current.

Compare the output current shown on the LCP keypad with measured motor current.

Display the Thermal Drive Load on the keypad and monitor the value. When running above the drive continuous current rating, the counter should increase. When running below the drive continuous current rating, the counter should decrease.

Note: See the derating section in the Design Guide for more details if a high switching frequency is required.

WARNING/ALARM 10, Motor overload temperature

According to the electronic thermal protection (ETR), the motor is too hot. Select whether the adjustable frequency drive gives a warning or an alarm when the counter reaches 100% in par. 1-90 *Motor Thermal Protection*. The fault is that the motor is overloaded by more than 100% for too long.

Troubleshooting:

- Check if the motor is overheating.
- If the motor is mechanically overloaded
- That the motor par. 1-24 *Motor Current* is set correctly.
- Motor data in parameters 1-20 through 1-25 are set correctly.
- The setting in parameter 1-91, Motor External Fan.
- Run AMA in parameter 1-29.

WARNING/ALARM 11, Motor thermistor overtemp

The thermistor or the thermistor connection is disconnected. Select whether the adjustable frequency drive gives a warning or an alarm when the counter reaches 100% in par. 1-90 *Motor Thermal Protection*.

Troubleshooting:

- Check if the motor is overheating.
- Check if the motor is mechanically overloaded.
- Check that the thermistor is connected correctly between terminal 53 or 54 (analog voltage input) and terminal 50 (+10 V supply), or between terminal 18 or 19 (digital input PNP only) and terminal 50.
- If a KTY sensor is used, check for correct connection between terminal 54 and 55.
- If using a thermal switch or thermistor, check the programming of parameter 1-93 matches sensor wiring.
- If using a KTY sensor, check the programming of parameters 1-95, 1-96, and 1-97 match sensor wiring.

WARNING/ALARM 12, Torque limit

The torque is higher than the value in par. 4-16 *Torque Limit Motor Mode* (in motor operation) or the torque is higher than the value in par. 4-17 *Torque Limit Generator Mode* (in regenerative operation). Parameter 14-25 can be used to change this from a warning only condition to a warning followed by an alarm.

WARNING/ALARM 13, Overcurrent

The inverter peak current limit (approx. 200% of the rated current) is exceeded. The warning lasts about 1.5 sec. Then the adjustable frequency drive trips and issues an alarm. If extended mechanical brake control is selected, trip can be reset externally.

Troubleshooting:

This fault may be caused by shock loading or fast acceleration with high inertia loads.

Turn off the adjustable frequency drive. Check if the motor shaft can be turned.

Make sure that the motor size matches the adjustable frequency drive.

Incorrect motor data in parameters 1-20 through 1-25.

ALARM 14, Ground fault

There is a discharge from the output phases to ground, either in the cable between the adjustable frequency drive and the motor or in the motor itself.

Troubleshooting:

Turn off the adjustable frequency drive and remove the ground fault.

Measure the resistance to ground of the motor leads and the motor with a megohmmeter to check for ground faults in the motor.

Perform current sensor test.

ALARM 15, Hardware mismatch

A fitted option is not operational with the present control board hardware or software.

Record the value of the following parameters and contact your Danfoss supplier:

- 15-40 FC Type
- 15-41 Power Section
- 15-42 Voltage
- 15-43 Software Version
- 15-45 Actual Typecode String
- 15-49 SW ID Control Card
- 15-50 SW ID Power Card
- 15-60 Option Mounted (for each option slot)
- 15-61 Option SW Version (for each option slot)

ALARM 16, Short circuit

There is short-circuiting in the motor or on the motor terminals. Turn off the adjustable frequency drive and remove the short-circuit.

WARNING/ALARM 17, Control word timeout

There is no communication to the adjustable frequency drive. The warning will only be active when par. 8-04 *Control Word Timeout Function* is NOT set to OFF. If par. 8-04 *Control Word Timeout Function* is set to *Stop* and *Trip*, a warning appears and the adjustable frequency drive ramps down until it trips, while giving an alarm.

Troubleshooting:

- Check connections on the serial communication cable.
- Increase par. 8-03 *Control Word Timeout Time*
- Check the operation of the communication equipment.
- Verify proper installation based on EMC requirements.

WARNING 22, Hoist Mech. Brake:

Report value will show what kind it is.
0 = The torque ref. was not reached before timeout.
1 = There was no brake feedback before timeout.

WARNING 23, Internal fan fault

The fan warning function is an extra protection function that checks if the fan is running / mounted. The fan warning can be disabled in par. 14-53 *Fan Monitor* ([0] Disabled).

For the D, E, and F Frame drives, the regulated voltage to the fans is monitored.

Troubleshooting:

- Check fan resistance.
- Check soft charge fuses.

WARNING 24, External fan fault

The fan warning function is an extra protection function that checks if the fan is running / mounted. The fan warning can be disabled in par. 14-53 *Fan Monitor* ([0] Disabled).

For the D, E, and F Frame drives, the regulated voltage to the fans is monitored.

Troubleshooting:

- Check fan resistance.
- Check soft charge fuses.

WARNING 25, Brake resistor short circuit

The brake resistor is monitored during operation. If it short circuits, the brake function is disconnected and the warning appears. The adjustable frequency drive still works, but without the brake function. Turn off the adjustable frequency drive and replace the brake resistor (see par. 2-15 *Brake Check*).

WARNING/ALARM 26, Brake resistor power limit

The power transmitted to the brake resistor is calculated as follows: as a percentage, as a mean value over the last 120 seconds, on the basis of the resistance value of the brake resistor, and the intermediate circuit voltage. The warning is active when the dissipated braking energy is higher than 90%. If *Trip* [2] has been selected in par. 2-13 *Brake Power Monitoring*, the adjustable frequency drive cuts out and issues this alarm, when the dissipated braking energy is higher than 100%.

Warning: There is a risk of substantial power being transmitted to the brake resistor if the brake transistor is short-circuited.

WARNING/ALARM 27, Brake chopper fault

The brake transistor is monitored during operation and if it short-circuits, the brake function disconnects and issues a warning. The adjustable frequency drive is still able to run, but since the brake transistor has short-circuited, substantial power is transmitted to the brake resistor, even if it is inactive.

Turn off the adjustable frequency drive and remove the brake resistor. This alarm/ warning could also occur should the brake resistor overheat. Terminal 104 to 106 are available as brake resistor. Klixon inputs, see section Brake Resistor Temperature Switch.

WARNING/ALARM 28, Brake check failed

Brake resistor fault: the brake resistor is not connected or not working. Check parameter 2-15, Brake Check.

ALARM 29, Heatsink temp

The maximum temperature of the heatsink has been exceeded. The temperature fault will not be reset until the temperature falls below a defined heatsink temperature. The trip and reset point are different based on the drive power size.

Troubleshooting:

- Ambient temperature too high.
- Too long motor cable.
- Incorrect clearance above and below the drive.
- Dirty heatsink.
- Blocked airflow around the drive.
- Damaged heatsink fan.

For the D, E, and F Frame Drives, this alarm is based on the temperature measured by the heatsink sensor mounted inside the IGBT modules. For the F Frame drives, this alarm can also be caused by the thermal sensor in the Rectifier module.

Troubleshooting:

- Check fan resistance.
- Check soft charge fuses.
- IGBT thermal sensor.

ALARM 30, Motor phase U missing

Motor phase U between the adjustable frequency drive and the motor is missing.

Turn off the adjustable frequency drive and check motor phase U.

ALARM 31, Motor phase V missing

Motor phase V between the adjustable frequency drive and the motor is missing.

Turn off the adjustable frequency drive and check motor phase V.

ALARM 32, Motor phase W missing

Motor phase W between the adjustable frequency drive and the motor is missing.

Turn off the adjustable frequency drive and check motor phase W.

ALARM 33, Inrush fault

Too many power-ups have occurred within a short time period. Let unit cool to operating temperature.

WARNING/ALARM 34, Fieldbus communication fault

The serial communication bus on the communication option card is not working.

WARNING/ALARM 36, Mains failure

This warning/alarm is only active if the supply voltage to the adjustable frequency drive is lost and par. 14-10 *Line Failure* is NOT set to OFF. Check the fuses to the adjustable frequency drive

ALARM 38, Internal fault

It may be necessary to contact your Danfoss supplier. Some typical alarm messages:

0	Serial port cannot be initialized. Serious hardware failure
256-258	Power EEPROM data is defect or too old
512	Control board EEPROM data is defect or too old
513	Communication time out reading EEPROM data
514	Communication time out reading EEPROM data
515	Application Orientated Control cannot recognize the EEPROM data
516	Cannot write to the EEPROM because a write command is on progress
517	Write command is under timeout
518	Failure in the EEPROM
519	Missing or invalid Barcode data in EEPROM
783	Parameter value outside of min/max limits
1024-1279	A CAN message that has to be sent, couldn't be sent
1281	Digital Signal Processor flash timeout
1282	Power micro software version mismatch
1283	Power EEPROM data version mismatch
1284	Cannot read Digital Signal Processor software version
1299	Option SW in slot A is too old
1300	Option SW in slot B is too old
1301	Option SW in slot C0 is too old
1302	Option SW in slot C1 is too old
1315	Option SW in slot A is not supported (not allowed)
1316	Option SW in slot B is not supported (not allowed)
1317	Option SW in slot C0 is not supported (not allowed)
1318	Option SW in slot C1 is not supported (not allowed)
1379	Option A did not respond when calculating Platform Version.
1380	Option B did not respond when calculating Platform Version.
1381	Option C0 did not respond when calculating Platform Version.
1382	Option C1 did not respond when calculating Platform Version.
1536	An exception in the Application Orientated Control is registered. Debug information written in LCP

1792	DSP watchdog is active. Debugging of power part data Motor Orientated Control data not transferred correctly
2049	Power data restarted
2064-2072	H081x: option in slot x has restarted
2080-2088	H082x: option in slot x has issued a power-up wait
2096-2104	H083x: option in slot x has issued a legal power-up wait
2304	Could not read any data from power EEPROM
2305	Missing SW version from power unit
2314	Missing power unit data from power unit
2315	Missing SW version from power unit
2316	Missing io_statepage from power unit
2324	Power card configuration is determined to be incorrect at power-up
2325	A power card has stopped communicating while main power is applied
2326	Power card configuration is determined to be incorrect after the delay for power cards to register
2327	Too many power card locations have been registered as present
2330	Power size information between the power cards does not match
2561	No communication from DSP to ATACD
2562	No communication from ATACD to DSP (state running)
2816	Stack overflow Control board module
2817	Scheduler slow tasks
2818	Fast tasks
2819	Parameter thread
2820	LCP Stack overflow
2821	Serial port overflow
2822	USB port overflow
2836	cfListMempool to small
3072-5122	Parameter value is outside its limits
5123	Option in slot A: Hardware incompatible with control board hardware
5124	Option in slot B: Hardware incompatible with control board hardware
5125	Option in slot C0: Hardware incompatible with control board hardware
5126	Option in slot C1: Hardware incompatible with control board hardware
5376-6231	Out of memory

ALARM 39, Heatsink sensor

No feedback from the heatsink temperature sensor.

The signal from the IGBT thermal sensor is not available on the power card. The problem could be on the power card, on the gate drive card, or the ribbon cable between the power card and gate drive card.

WARNING 40, Overload of Digital Output Terminal 27

Check the load connected to terminal 27 or remove short-circuit connection. Check par. 5-00 *Digital I/O Mode* and par. 5-01 *Terminal 27 Mode*.

WARNING 41, Overload of Digital Output Terminal 29

Check the load connected to terminal 29 or remove short-circuit connection. Check par. 5-00 *Digital I/O Mode* and par. 5-02 *Terminal 29 Mode*.

WARNING 42, Overload of Digital Output on X30/6 or Overload of Digital Output on X30/7

For X30/6, check the load connected to X30/6 or remove short-circuit connection. Check par. 5-32 *Term X30/6 Digi Out (MCB 101)*.

For X30/7, check the load connected to X30/7 or remove short-circuit connection. Check par. 5-33 *Term X30/7 Digi Out (MCB 101)*.

ALARM 46, Power card supply

The supply on the power card is out of range.

There are three power supplies generated by the switch mode power supply (SMPS) on the power card: 24 V, 5 V, +/-18 V. When powered with 24 VDC with the MCB 107 option, only the 24 V and 5 V supplies are monitored. When powered with three-phase AC line voltage, all three supplied are monitored.

WARNING 47, 24 V supply low

The 24 VDC is measured on the control card. The external 24 VDC backup power supply may be overloaded, otherwise contact your Danfoss supplier.

WARNING 48, 1.8 V supply low

The 1.8 Volt DC supply used on the control card is outside of allowable limits. The power supply is measured on the control card.

WARNING 49, Speed limit

The speed is not within the specified range in par. 4-11 *Motor Speed Low Limit [RPM]* and par. 4-13 *Motor Speed High Limit [RPM]*.

ALARM 50, AMA calibration failed

Contact your Danfoss supplier.

ALARM 51, AMA check Unom and Inom

The setting of the motor voltage, motor current, and motor power is presumably wrong. Check the settings.

ALARM 52, AMA low Inom

The motor current is too low. Check the settings.

ALARM 53, AMA big motor

The motor is too big for the AMA to be carried out.

ALARM 54, AMA small motor

The motor is too big for the AMA to be carried out.

ALARM 55, AMA parameter out of range

The parameter values found from the motor are outside acceptable range.

ALARM 56, AMA interrupted by user

The AMA has been interrupted by the user.

ALARM 57, AMA timeout

Try to start the AMA again a number of times, until the AMA is carried out. Please note that repeated runs may heat the motor to a level where the resistances R_s and R_r are increased. In most cases, however, this is not critical.

ALARM 58, AMA internal fault

Contact your Danfoss supplier.

WARNING 59, Current limit

The current is higher than the value in par. 4-18, *Current Limit*.

WARNING 60, External interlock

External interlock has been activated. To resume normal operation, apply 24 VDC to the terminal programmed for external interlock and reset the adjustable frequency drive (via serial communication, digital I/O, or by pressing reset button on keypad).

WARNING 61, Tracking error

An error has been detected between the calculated motor speed and the speed measurement from the feedback device. The function for Warning/Alarm/Disable is set in par 4-30, *Motor Feedback Loss Function*, error setting in par 4-31, *Motor Feedback Speed Error*, and the allowed error

time in par 4-32, *Motor Feedback Loss Timeout*. During a commissioning procedure the function may be effective.

WARNING 62, Output frequency at maximum limit

The output frequency is higher than the value set in par. 4-19 *Max Output Frequency*

WARNING 64, Voltage limit

The load and speed combination demands a motor voltage higher than the actual DC link voltage.

WARNING/ALARM/TRIP 65, Control card overtemperature

Control card overtemperature: The cut-out temperature of the control card is 176°F [80°C].

WARNING 66, Heatsink temperature low

This warning is based on the temperature sensor in the IGBT module.

Troubleshooting:

The heatsink temperature measured as 32°F [0°C] could indicate that the temperature sensor is defective causing the fan speed to increase to the maximum. If the sensor wire between the IGBT and the gate drive card is disconnected, this warning is produced. Also, check the IGBT thermal sensor.

ALARM 67, Option module configuration has changed

One or more options have either been added or removed since the last power-down.

ALARM 68, Safe stop activated

Safe stop has been activated. To resume normal operation, apply 24 VDC to terminal 37, then send a reset signal (via Bus, Digital I/O, or by pressing the reset key. See parameter 5-19, Terminal 37 Safe Stop.

ALARM 69, Power card temperature

The temperature sensor on the power card is either too hot or too cold.

Troubleshooting:

Check the operation of the door fans.

Make sure that the filters for the door fans are not blocked.

Make sure that the gland plate is properly installed on IP 21 and IP 54 (NEMA 1 and NEMA 12) drives.

ALARM 70, Illegal FC Configuration

The current control board and power board combination is illegal.

WARNING/ALARM 71, PTC 1 safe stop

Safe Stop has been activated from the MCB 112 PTC Thermistor Card (motor too warm). Normal operation can be resumed when the MCB 112 applies 24 V DC to T-37 again (when the motor temperature reaches an acceptable level) and when the digital input from the MCB 112 is deactivated. When that happens, a reset signal must be sent (via serial communication, digital I/O, or by pressing reset button on keypad). Note that if automatic restart is enabled, the motor may start when the fault is cleared.

ALARM 72, Dangerous failure

Safe stop with trip lock. Unexpected signal levels on safe stop and digital input from the MCB 112 PTC thermistor card.

Warning 73, Safe stop auto restart

Safe stopped. Note that with automatic restart enabled, the motor may start when the fault is cleared.

Warning 76, Power Unit Setup

The required number of power units does not match the detected number of active power units.

Troubleshooting:

When replacing an F frame, module this will occur if the power specific data in the module power card does not match the rest of the drive. Please confirm the spare part and its power card are the correct part number.

WARNING 77, Reduced power mode:

This warning indicates that the drive is operating in reduced power mode (i.e., less than the allowed number of inverter sections). This warning will be generated on power cycle when the drive is set to run with fewer inverters and will remain on.

ALARM 79, Illegal power section configuration

The scaling card is the incorrect part number or not installed. Also MK102 connector on the power card could not be installed.

ALARM 80, Drive initialized to default value

Parameter settings are initialized to default settings after a manual reset.

WARNING 81, CSIV corrupt:

CSIV file has syntax errors.

WARNING 82, CSIV parameter error:

CSIV param error

WARNING 85, Dang fail PB:

Profibus/Profisafe Error

ALARM 91, Analog input 54 wrong settings

Switch S202 has to be set in position OFF (voltage input) when a KTY sensor is connected to analog input terminal 54.

ALARM 243, Brake IGBT

This alarm is only for F Frame drives. It is equivalent to Alarm 27. The report value in the alarm log indicates which power module generated the alarm:

- 1 = left most inverter module.
- 2 = middle inverter module in F2 or F4 drive.
- 2 = right inverter module in F1 or F3 drive.
- 3 = right inverter module in F2 or F4 drive.
- 5 = rectifier module.

ALARM 244, Heatsink temperature

This alarm is only for F Frame drives. It is equivalent to Alarm 29. The report value in the alarm log indicates which power module generated the alarm:

- 1 = left most inverter module.
- 2 = middle inverter module in F2 or F4 drive.
- 2 = right inverter module in F1 or F3 drive.
- 3 = right inverter module in F2 or F4 drive.
- 5 = rectifier module.

ALARM 245, Heatsink sensor

This alarm is only for F Frame drives. It is equivalent to Alarm 39. The report value in the alarm log indicates which power module generated the alarm:

- 1 = left most inverter module.
- 2 = middle inverter module in F2 or F4 drive.
- 2 = right inverter module in F1 or F3 drive.
- 3 = right inverter module in F2 or F4 drive.
- 5 = rectifier module.

ALARM 246, Power card supply

This alarm is only for F Frame drives. It is equivalent to Alarm 46. The report value in the alarm log indicates which power module generated the alarm:

- 1 = left most inverter module.
- 2 = middle inverter module in F2 or F4 drive.
- 2 = right inverter module in F1 or F3 drive.
- 3 = right inverter module in F2 or F4 drive.
- 5 = rectifier module.

ALARM 247, Power card temperature

This alarm is only for F Frame drives. It is equivalent to Alarm 69. The report value in the alarm log indicates which power module generated the alarm:

- 1 = left most inverter module.
- 2 = middle inverter module in F2 or F4 drive.
- 2 = right inverter module in F1 or F3 drive.
- 3 = right inverter module in F2 or F4 drive.
- 5 = rectifier module.

ALARM 248, Illegal power section configuration

This alarm is only for F-frame drives. It is equivalent to Alarm 79. The report value in the alarm log indicates which power module generated the alarm:

- 1 = left most inverter module.
- 2 = middle inverter module in F2 or F4 drive.
- 2 = right inverter module in F1 or F3 drive.
- 3 = right inverter module in F2 or F4 drive.
- 5 = rectifier module.

ALARM 250, New spare part

The power or switch mode power supply has been exchanged. The adjustable frequency drive type code must be restored in the EEPROM. Select the correct type code in par. 14-23 *Typecode Setting* according to the label on the unit. Remember to select 'Save to EEPROM' to complete.

ALARM 251, New type code

The adjustable frequency drive has a new type code.

Index

2

24 Vdc Power Supply	3-41
---------------------------	------

3

30 Ampere, Fuse-protected Terminals	3-40
---	------

A

Abbreviations	1-3
Ac Line Input Connection	3-58
Access To Control Terminals	3-67
Airflow	3-26
Alarm Messages	6-1
Ama	3-74
Analog Inputs	5-2
Analog Output	5-3
Approvals	1-1
Automatic Motor Adaptation (ama)	3-74, 4-7

B

Back Cooling	3-26
Brake Cable	3-56
Brake Control	6-6
Brake Resistor Temperature Switch	3-65

C

Cable Lengths And Cross-sections	5-4
Cable Positions	3-17
Cable-length And Cross-section:	3-42
Cabling	3-42
Communication Option	6-7
Connector/conduit Entry - Ip21 (nema 1) And Ip54 (nema12)	3-29
Control Cables	3-72
Control Cables	3-71
Control Card Performance	5-4
Control Card, +10 V Dc Output	5-3
Control Card, 24 V Dc Output	5-3
Control Card, Rs-485 Serial Communication	5-4
Control Card, Usb Serial Communication	5-4
Control Characteristics	5-4
Control Terminals	3-68
Cooling	3-26

D

Dc Link	6-5
Default Settings	4-9
Devicenet	1-1
Digital Inputs:	5-1
Digital Output	5-3
Disposal Instructions	2-1
Drip Shield Installation	3-31
Drives With Factory Installed Brake Chopper Option	3-56
Duct Cooling	3-26
Duct Work Cooling Kits	3-32

E

Elcb Relays	3-53
Electrical Installation	3-68, 3-71
External Fan Supply	3-58
External Temperature Monitoring	3-41

F

Floor Mounting	3-37
Frame Size F Panel Options	3-2
Fuses	3-59
Fusing	3-42

G

General Considerations	3-14
General Warning	2-2
Graphical Display	4-1
Ground Leakage Current	2-2
Grounding	3-53

H

High Power Fuse Tables	3-59
------------------------------	------

I

Iec Emergency Stop With Pilz Safety Relay	3-40
Input Polarity Of Control Terminals	3-72
Installation Of 24 Volt External Dc Supply	3-67
Installation Of Duct Cooling Kit In Rittal	3-32
Installation Of Input Plate Options	3-38
Installation Of Line Power Shield For Adjustable Frequency Drives	3-38
Installation On Pedestal	3-37
Installation On The Wall - Ip21 (nema 1) And Ip54 (nema 12) Units	3-28
Insulation Resistance Monitor (irm)	3-40
It Line Power	3-53

K

Kty Sensor	6-5
------------------	-----

L

Language 0-01	4-4
Language Package 1	4-4
Language Package 2	4-4
Language Package 3	4-4
Language Package 4	4-4
Leakage Current	2-2
Leds	4-1, 4-2
Lifting	3-3
Line Power Supply (I1, L2, L3)	5-1
Load Sharing	3-56
Local Control Panel	4-2

M

Main Reactance	4-7
Manual Motor Starters	3-40
Maximum Reference 3-03	4-7
Mechanical Brake Control	3-76
Mechanical Dimensions	3-11

Mechanical Dimensions	3-5
Mechanical Installation	3-14
Minimum Reference 3-02	4-7
Motor Cable	3-55
Motor Current 1-24	4-5
Motor Frequency 1-23	4-5
Motor Nameplate	3-74
Motor Nominal Speed 1-25	4-5
Motor Output	5-1
Motor Overload Protection	2-2
[Motor Power Kw] 1-20	4-5
Motor Protection	5-5
Motor Thermal Protection	3-77
Motor Voltage 1-22	4-5

N

Nameplate Data	3-74
Namur	3-40
Non-ul Compliance	3-59
Numerical Display	4-2

O

Ordering	3-33
Output Performance (u, V, W)	5-1
Outside Installation/ Nema 3r Kit For Rittal	3-35

P

Parallel Connection Of Motors	3-76
Pedestal Installation	3-37
Planning The Installation Site	3-1
Potentiometer Reference	3-70
Power Connections	3-42
Profibus	1-1
Protection	3-59
Protection And Features	5-5
Pulse Start/stop	3-69
Pulse/encoder Inputs	5-3

R

Ramp 1 Ramp-down Time 3-42	4-8
Ramp 1 Ramp-up Time 3-41	4-8
Rated Power	3-12
Rcd (residual Current Device)	3-40
Receiving The Adjustable Frequency Drive	3-1
Relay Outputs	5-4
Repair Work	2-2
Residual Current Device	2-2
Rfi Switch	3-53

S

Safe Stop	2-3
Safe Stop Installation	2-5
Safety Category 3 (en 954-1)	2-5
Safety Instructions	2-2
Serial Communication	5-4
Serial Communication Bus Connection	3-66
Shielded Cables	3-54
Shielded/armored	3-72
Shielding Of Cables:	3-42
Sine-wave Filter	3-43

Space	3-14
Space Heaters And Thermostat	3-39
Speed Up/down	3-70
Start/stop	3-69
Stator Leakage Reactance	4-7
Status Messages	4-1
Stopping Category 0 (en 60204-1)	2-5
Surroundings	5-4
Switches S201, S202, And S801	3-73
Switching Frequency:	3-42
Symbols	1-2

T

Terminal Locations	3-18
Terminal Locations - Frame Size D	3-1
Torque	3-54
Torque Characteristics	5-1
Torque For Terminals	3-54

U

Unintended Start	2-2
Unpacking	3-2

V

Voltage Level	5-1
Voltage Reference Via A Potentiometer	3-70

W

Warnings	6-1
Wire Access	3-15