

**■ Contents**

|   |           |
|---|-----------|
| <b>Introduction</b>   | <b>3</b>  |
| About this manual   | 3         |
| Assumptions   | 3         |
| What you should already know                                    | 3         |
| Available literature  | 4         |
| Supplied with the unit  | 4         |
| Product and Environment   | 5         |
| Network   | 5         |
| User Profile  | 5         |
| Interface to DeviceNet Network                                  | 5         |
| Data Communication Interface                                    | 5         |
| Overall Function  | 5         |
| Control Card Self-test  | 5         |
| <br>  |           |
| <b>Technical Data</b>   | <b>6</b>  |
| Cable Lengths   | 6         |
| Topology  | 6         |
| Cable Specifications  | 7         |
| Network Power Supply  | 7         |
| Cable Cross Section   | 7         |
| EMC Precautions   | 8         |
| VLT Response Time   | 9         |
| <br>  |           |
| <b>Electrical Installation</b>                                  | <b>10</b> |
| VLT 2800 Connection of the Cable Screen                         | 10        |
| VLT 2800 Earth Connection                                       | 10        |
| VLT 2800 DeviceNet Connection                                   | 10        |
| FCD 300 Electrical connection                                   | 11        |
| User Interface  | 12        |
| Quick Setup   | 12        |
| <br>  |           |
| <b>Master-Slave configuration</b>                               | <b>13</b> |
| <br>  |           |
| <b>Drive Profile</b>  | <b>14</b> |
| I/O Assembly Instances  | 14        |
| Control Word and Status Word under Instance 20/70               | 14        |
| Control Word and Status Word under Instance 21/71               | 15        |
| Bus speed reference value, under Instance 20/70 and 21/71       | 16        |
| Actual output speed, under Instance 20/70 and 21/71             | 16        |
| Control Word and Status Word under Instance 100/150 and 101/151 | 16        |
| Bus reference value   | 19        |
| Actual output frequency   | 19        |
| Process Data, PCD   | 20        |
| <br>  |           |
| <b>DeviceNet object classes</b>                                 | <b>21</b> |
| Class Code 0x01   | 21        |
| Class Code 0x02   | 21        |

---

**VLT® 2800/FCD 300 DeviceNet**

---

|   |           |
|---|-----------|
| Class Code 0x03                                 | 21        |
| Class Code 0x04                                 | 21        |
| Class Code 0x05                                 | 22        |
| Class Code 0x28                                 | 24        |
| Class Code 0x29                                 | 24        |
| Class Code 0x2A                                 | 25        |
| Danfoss Classes                                 | 26        |
| <b>DeviceNet Operation Mode</b>                 | <b>27</b> |
| Bit Strobe                                      | 27        |
| Polling   | 28        |
| Change of State, COS                            | 28        |
| <b>EDS Files</b>                                | <b>29</b> |
| VLT 2800 US version with DeviceNet              | 29        |
| VLT 2800 European version with DeviceNet        | 29        |
| FCD 300 European version with DeviceNet         | 29        |
| <b>Programming</b>                              | <b>30</b> |
| Special Attention                               | 30        |
| Warning and Alarm Messages                      | 39        |
| Warning and Alarm Messages                      | 39        |
| Abbreviations                                   | 40        |
| Factory settings - VLT 2800                     | 41        |
| Factory settings - FCD 300                      | 49        |
| <b>Additional control features for VLT 2800</b> | <b>56</b> |

**■ Introduction****■ About this manual**

This manual is intended to be used both as an instructional and as a reference manual. It only briefly touches on the basics of the DeviceNet protocol. Whenever it is necessary for gaining an understanding of the AC Drive Profile, please refer to the ODVA version 2.0. The manual is also intended to serve as a guideline when you specify and optimize your communication SYSTEM.

Even if you are an experienced DeviceNet programmer, we suggest that you read this manual in its entirety before you start programming, since important information can be found in all chapters.

**Installation at high altitudes**

At altitudes higher than 6,600 feet [2 km], please contact Danfoss Drives regarding PELV.

---

**■ Assumptions**

This manual assumes that you are using a DANFOSS VLT 2800 or FCD 300 unit with DeviceNet. It is also assumed that you are using a PLC or PC, as a master, that is equipped with a serial communication card supporting all the DeviceNet communication services required by your application. Further more it is assumed that all requirements stipulated in the DeviceNet standard as well as those set up in the AC Drive Profile and those pertaining to the VLT Variable Speed Drive are strictly observed as well as all limitations therein fully respected.

---

**■ What you should already know**

The DANFOSS DeviceNet is designed to communicate with any master abiding by the DeviceNet standard. It is therefore assumed that you have full knowledge of the PC or PLC you intend to use as a master in your SYSTEM. Any questions pertaining to hardware or software produced by any other manufacturer is beyond the scope of this manual and is of no concern to DANFOSS.

If you have questions about how to set up master - master communication or communication to a non-Danfoss slave, the appropriate manuals should be consulted.

---

**■ Available literature****■ Supplied with the unit**

Below is a list of the literature available for VLT 2800 and FCD 300. It must be noted that there may be deviations from one country to the next.

**Supplied with the unit:**

|                        |             |
|------------------------|-------------|
| Operating instructions | MG.27.AX.YY |
| Quick setup            | MG.28.AX.62 |
| Parameter list         | MG.28.DX.YY |

**Various literature:**

|                           |             |
|---------------------------|-------------|
| Design Guide for VLT 2800 | MG.27.EX.YY |
| Data sheet for VLT 2800   | MD.27.AX.YY |
| Design Guide for FCD 300  | MG.04.AX.YY |
| Data sheet for FCD 300    | MD.04.AX.YY |

**Instructions for VLT 2800:**

|                         |             |
|-------------------------|-------------|
| Assembly/disassembly    | MI.28.A1.02 |
| LCP remote-mounting kit | MI.56.AX.51 |
| Filter instruction      | MI.28.B1.02 |

**Communication with VLT 2800 and FCD 300:**

|                           |             |
|---------------------------|-------------|
| Profibus manual           | MG.90.AX.YY |
| VLT 2800 DeviceNet manual | MG.90.BX.YY |

*X = version number YY = language version*

**■ Product and Environment**

DeviceNet is a distributed control network. The DeviceNet protocol is embedded in the control card and is a communication protocol conforming to the Open DeviceNet Vendor Association (ODVA) standard.

The control card allows DeviceNet compatible controllers, sensors, and network management tools to control, monitor, and supervise the VLT frequency converter. The control card is designed to the DeviceNet System Protocol for Vendors as a slave device.

---

**■ Network**

The VLT frequency converter will function as a slave on the DeviceNet network. All addressing and linking to nodes is done at installation time by a network manager tool. The network installer and the network management master have a significant influence on how the node functions on the network. A DeviceNet network can support up to 64 nodes.

---

**■ User Profile**

The end-user is a network manager programmer or a controller who see the DeviceNet control card as a transparent bridge to the VLT frequency converter. Control and supervision of the VLT frequency converter will still be possible through the standard parameter set.

---

**■ Interface to DeviceNet Network**

The Interface connection to the DeviceNet network is implemented through a CAN chip. Four different I/O Assembly is available in the VLT frequency converter DeviceNet interface, which can be configured by the user. The I/O assembly can handle Polled mode, Bit Strobe, Change of state (COS) and Cyclic. For explicit messages, the interface has two Unconnected Messages Manager (UCMM) available. This allows two nodes on the DeviceNet to directly access parameters in the VLT frequency converter without involving a pre-configured master.

---

**■ Data Communication Interface**

No direct data communication interface (e.g. via a serial port) other than the DeviceNet interface and the VLT frequency converter interface is considered.

LCP2 or Dialog can be used on the Sub D plug while using DeviceNet.

**■ Overall Function**

DeviceNet is a low-level network that standardizes communications between industrial devices (sensors, limit switches) and high level devices (controllers). The communication network can be peer to peer or master/slave. DeviceNet uses CAN technology for Media Access Control and Physical Signaling and it supports up to 64 nodes. DeviceNet also defines device profiles for devices belonging to specific classes. For other devices, a custom class must be defined in order to make it DeviceNet compatible. This further enhances the interchangeability and interoperability of the network. Each node on the network has its own unique media access control identifier (MAC ID) to distinguish it on the network.

---

**■ Control Card Self-test**

Please refer to parameter 620 in the *Programming* chapter.

---

## VLT® 2800/FCD 300 DeviceNet

■ **Technical Data**

■ **Cable Lengths**

| Baud Rate | Max. total cable length [m] | Drop Length                       |                      |
|-----------|-----------------------------|-----------------------------------|----------------------|
|           |                             | Maximum                           | Cumulative           |
| 125k baud | 500 meters (1640 ft.)       | 6 meters (20 ft.)<br>for one drop | 156 meters (512 ft.) |
| 250k baud | 250 meters (820 ft.)        |                                   | 78 meters (256 ft.)  |
| 500k baud | 100 meters (328 ft.)        |                                   | 39 meters (128 ft.)  |

■ **Topology**

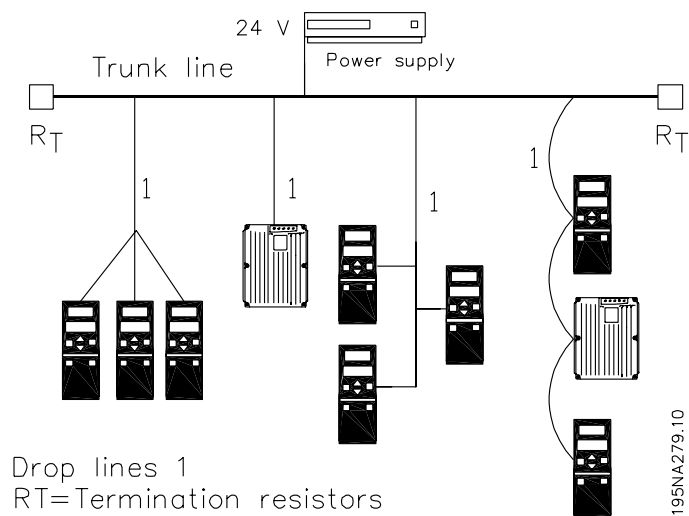

### ■ Cable Specifications

The cable is to be used according to ODVA specifications.

### ■ Network Power Supply

The DeviceNet option is an optically isolated node, where transceiver power is provided by the network.

External network power supply requirements are:

11 - 25 VDC

10 mA draw per VLT frequency converter node.

### ■ Cable Cross Section

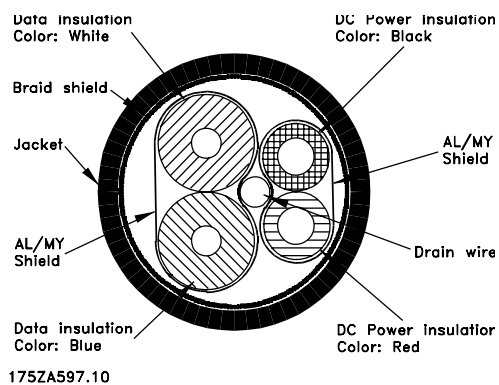

### ■ EMC Precautions

The following EMC precautions are recommended to obtain interference free operation of the DeviceNet network. Additional information on EMC can be found in the FCD 300 and in the VLT 2800 Series Operating Instructions and Design Guide.



#### NB!

Relevant national and local regulations, for example regarding protective earth connection, must be observed.

The DeviceNet communication cable must be kept away from motor and brake resistor cables to avoid coupling of high frequency noise from one cable to the other. Normally a distance of 200 mm (8 inches) is sufficient, but it is generally recommended to keep the greatest possible distance between the cables, especially where cables are running in parallel over long distances.

If the DeviceNet cable has to cross a motor and brake resistor cable they must cross each other at an angle of 90°.

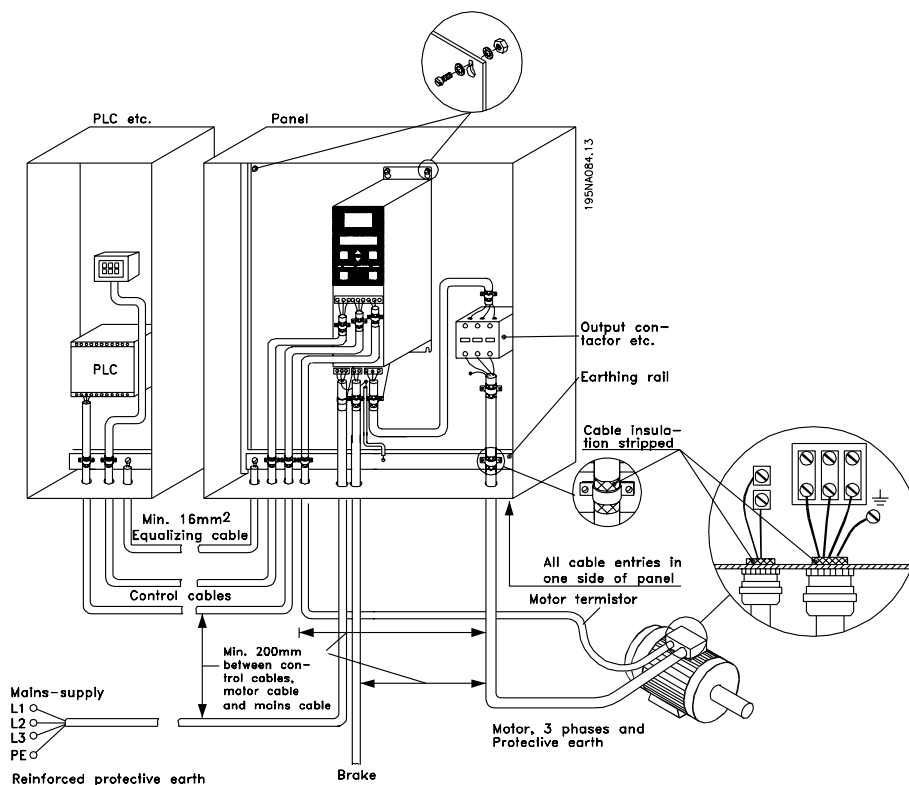

Example: VLT 2800 panel mounting



### ■ VLT Response Time

The update time via the DeviceNet connection can be divided into two parts:

1. The communication time, which is the time it takes to transmit data from the master to the slave (VLT with DeviceNet option).
2. The internal update time, which is the time it takes to transmit data between the VLT frequency converter control card and the DeviceNet interface.

Communication time ( $t_{com}$ ) depends on the actual transmission speed (baudrate) and the type of master in use. More slaves or lower transmission speed will increase the communication time.

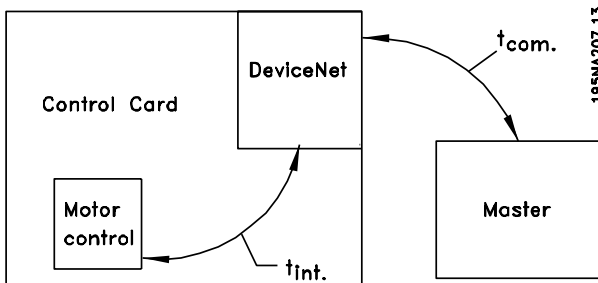

| Data  | Update time, $t_{int}$ |
|---|------------------------|
| Control word via I/O instances                              | 14 msec                |
| Main actual value via I/O instances                         | 44 msec                |
| Status word via I/O instances                               | 14 msec                |
| Reference via I/O instances                                 | 44 msec                |
| Control via Class Code 0x29                                 | 14 msec                |
| Reference via Class Code 0x2A                               | 44 msec                |
| Change of parameter via Explicit message and Danfoss Object | 94 msec                |
| Read of parameter via Explicit message and Danfoss Object   | 14 msec                |

### ■ Electrical Installation

#### ■ VLT 2800 Connection of the Cable Screen

Danfoss recommends that the screen of the DeviceNet cable be connected to ground at both ends of the cable at every DeviceNet station (see *Danfoss recommendation* for further details).

It is very important to have a low impedance ground connection of the screen, also at high frequencies. This can be obtained by connecting the surface of the screen to ground, for example by means of a cable clamp or a conductive cable gland. VLT frequency converter Series are provided with different clamps and brackets to enable a proper ground connection of the DeviceNet cable screen. The screen connection is shown in the drawing.

**For fulfilling the CE and EMC compliance.**

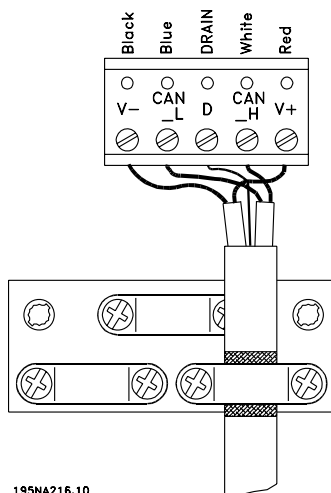

#### VLT 2800 ODVA recommendation

Screen must be connected to ground at only one point on the network.



#### NB!

Please note, that this recommendation conflicts with the EMC correct installation.

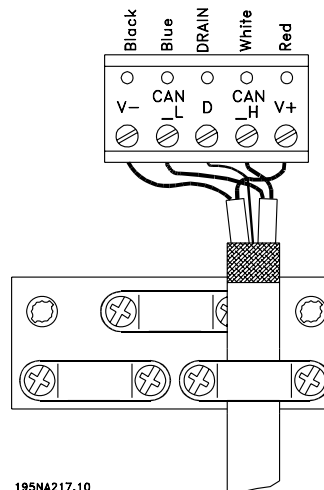

#### ■ VLT 2800 Earth Connection

It is important that all stations connected to the DeviceNet network are connected to the same earth potential. The earth connection must have a low HF (high frequency) impedance. This can be achieved by connecting a large surface area of the cabinet to ground, for example by mounting the VLT frequency converter on a conductive rear plate. Especially when having long distances between the stations in a DeviceNet network it can be necessary to use additional potential equalizing cables, connecting the individual stations to the same earth potential.

#### ■ VLT 2800 DeviceNet Connection

It is essential that the bus line be terminated properly. A mismatch of impedance may result in reflections on the line that will corrupt data transmission.

The DeviceNet control card is provided with a pluggable connector.

By using a pluggable connector as a splice between two trunk lines, removal of devices will not sever the network. Strain relief, if required, must be provided by the developer. In current installations of this type of connector, the strain relief is attached to the product.



#### NB!

Wires should not be installed while the network is active. This will prevent problems such as shorting the network supply or disrupting communications.

#### VLT 2800 Drop cable

An alternative to splicing two trunk lines in the connector on the control card, is using a DeviceNet connection box or a T-connector. For this kind of installation a drop cable is available as an option.

Drop cable ordering number: 195N3113

## VLT® 2800/FCD 300 DeviceNet

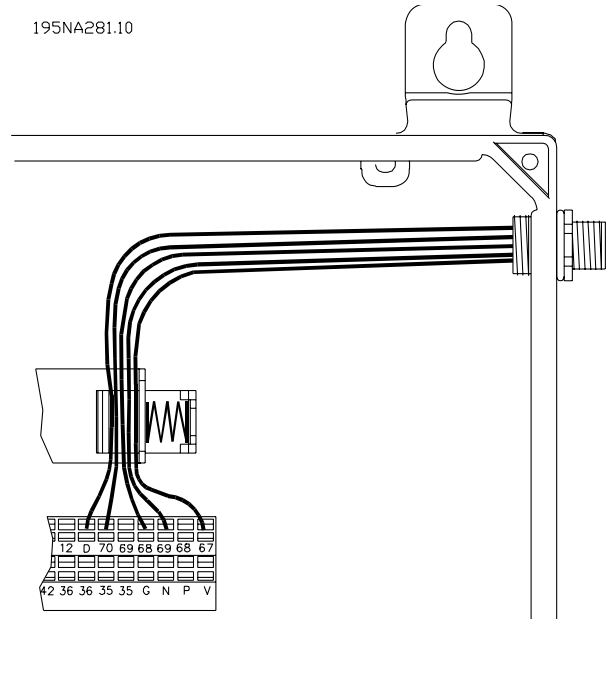
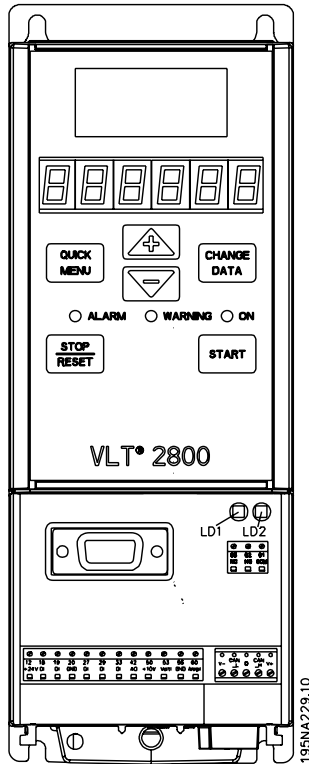
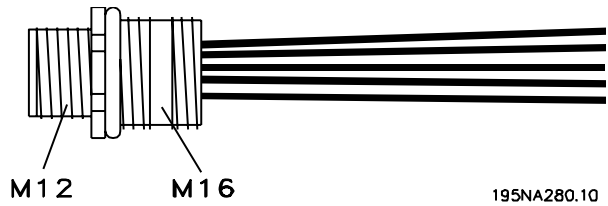
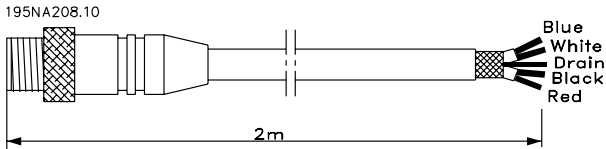

### NB!

Please note, that terminal 46 has been removed from the DeviceNet card, meaning that parameter 341-342 are not having any function.

### ■ FCD 300 Electrical connection

The DeviceNet bus connection can be performed through a plug, that is to be mounted in the FCD 300 housing (M16 gland hole) and wired to the inside terminal strip.

### Wiring list

| M12 Circular connector | Terminal strip | Colour | Function |
|------------------------|----------------|--------|----------|
| 4                      | 68             | White  | Can high |
| 5                      | 69             | Blue   | Can low  |
| 2                      | 67             | Red    | + 24 V   |
| 3                      | 70             | Black  | GND      |
| 1                      | D              | Green  | Drain    |

### DeviceNet plug 175N2279

### ■ User Interface

The DeviceNet control card contains two bi-color (green/red) LED's for each connector hookup port, to indicate the state of the device and network, respectively.

| Module LED:                             |  |                                       |
|---|--|---------------------------------------|
| LD1 on VLT 2800 Dual colour (Green/Red) | Yellow FCD 300 STATUS LED when selected as DeviceNet in parameter 26 | VLT status                            |
| OFF                                     | OFF  | Device is OFF                         |
| GREEN                                   | YELLOW   | Device is operational                 |
| Flashing GREEN                          | Flashing YELLOW  | Device is in standby                  |
| Flashing RED                            | OFF  | Device detects a recoverable fault    |
| RED                                     | OFF  | Device detects an unrecoverable fault |
| Flashing GREEN/RED                      | Flashing YELLOW  | Device is self testing                |

| NETWORK LED:                         |   |                          |                                      |
|--------------------------------------|---|--------------------------|--------------------------------------|
| VLT status                           | LD2 on VLT 2800 Dual colour (Green/Red) | Green BUS LED on FCD 300 | VLT status                           |
| Network is non-powered/not on-line   | OFF                                     | OFF                      | Network is non-powered/not on-line   |
| Network is on-line but not connected | Flashing GREEN                          | Flashing GREEN           | Network is on-line but not connected |
| Network is on-line and connected     | GREEN                                   | GREEN                    | Network is on-line and connected     |
| Network has a connection time-out    | Flashing RED                            | OFF                      | Network has a connection time-out    |
| Network has a critical link failure  | RED                                     | OFF                      | Network has a critical link failure  |

### ■ Quick Setup

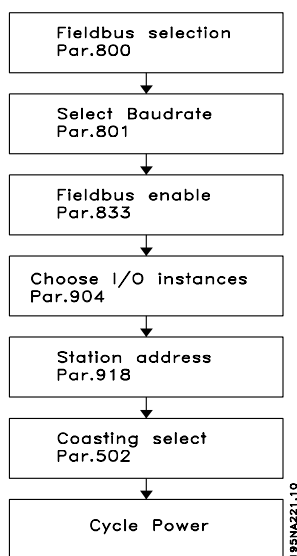

Parameter 800 = "Fieldbus selection".

Parameter 833 = "Fieldbus enable".

Parameter 918 = "Select Bus address".

Parameter 801 = "Select Baudrate".

Parameter 904 = "Choose I/O instances".

Parameter 502 = "Coasting select".

**■ Master-Slave configuration****■ System configuration**

The SYSTEM configuration of a DeviceNet master and a VLT 2800/FCD 300 can be split up into two parts.

The first part is the setting of DeviceNet communication related parameters. These are the baud rate and station address/MAC ID.

By VLT 2800/FCD 300 these parameters can be set by the LCP or access via a DeviceNet configuration tool. None of these parameters can be set by mechanical switches.

After the baud rate and station address/MAC ID are set a connection to a DeviceNet DeviceNet configuration tool can be established.

The second and larger area of a SYSTEM configuration is the setting of application related parameters.

EDS files are easy to create and it is strongly recommended to generate an EDS for each VLT 2800/FCD 300. This can be done by uploading the EDS file from each drive by a DeviceNet configuration tool. In the VLT 2800/FCD 300 EDS file it is possible to configure the drive and read or write to parameters. The language of the EDS file is depending of the actual setting of parameter 001 *Language*.

In parameter 838 *EDS Data type* it is possible to choose between two dataformat for uploading EDS files. Before uploading the EDS file please check if the master support Errata 1 or Errata 2.

For Off-line configuration Danfoss can provide you with english EDS files, see section *EDS files* for the EDS file name. Contact your local Danfoss supplier for the EDS files.

Another important configuration parameter is the selection of communication mechanisms that enable an efficient and responsive I/O SYSTEM. By VLT 2800/FCD 300 it is possible to choose between the following communication mechanisms:

- Poll I/O
- Bit Strobe I/O
- Change-of-state (COS) / Cyclic I/O
- Explicit Messaging

See *DeviceNet Operation Mode* in this manual for further information.

The last configuration parameter is the choice of Instance type in parameter 904 *PPO selection*. Here is it possible to select between a Danfoss Specific profile (Instance 100/150 or 101/151) or a ODVA Specific AC Drive profile (Instance 20/70 or 21/71).

### ■ Drive Profile

#### ■ I/O Assembly Instances

The I/O Assembly Instance definitions in this section define the format of the "data" attribute (attribute 3) for I/O Assembly Instances. I/O Assemblies support a hierarchy of motor control devices. The device hierarchy includes motor starters, soft starters, AC and DC drives, and servo drives. Assembly Instances are numbered within the hierarchy so that each device type is assigned a range of Assembly Instance numbers, with higher functionality devices supporting higher instance numbers. Devices in the hierarchy can choose to support instance numbers that are lower than theirs in the hierarchy. For example an AC drive may choose to support some I/O Assemblies in the starter profile to make it easier to interchange starters and drives within the SYSTEM.

bers, with higher functionality devices supporting higher instance numbers. Devices in the hierarchy can choose to support instance numbers that are lower than theirs in the hierarchy. For example an AC drive may choose to support some I/O Assemblies in the starter profile to make it easier to interchange starters and drives within the SYSTEM.

| I/O Instances<br>Par.904 | Output assembly word  | Input assembly word   | Drive profile |
|--------------------------|---|---|---------------|
| 20/70                    | <div style="display: inline-block; border: 1px solid black; padding: 2px;">CTW</div> <div style="display: inline-block; border: 1px solid black; padding: 2px; margin-left: 5px;">Speed ref.<br/>RPM</div>  | <div style="display: inline-block; border: 1px solid black; padding: 2px;">STW</div> <div style="display: inline-block; border: 1px solid black; padding: 2px; margin-left: 5px;">Actual<br/>RPM</div>  | ODVA          |
| 21/71                    | <div style="display: inline-block; border: 1px solid black; padding: 2px;">CTW</div> <div style="display: inline-block; border: 1px solid black; padding: 2px; margin-left: 5px;">Speed ref.<br/>RPM</div>  | <div style="display: inline-block; border: 1px solid black; padding: 2px;">STW</div> <div style="display: inline-block; border: 1px solid black; padding: 2px; margin-left: 5px;">Actual<br/>RPM</div>  | ODVA          |
| 100/150                  | <div style="display: inline-block; border: 1px solid black; padding: 2px;">CTW</div> <div style="display: inline-block; border: 1px solid black; padding: 2px; margin-left: 5px;">MRV</div>   | <div style="display: inline-block; border: 1px solid black; padding: 2px;">STW</div> <div style="display: inline-block; border: 1px solid black; padding: 2px; margin-left: 5px;">MAV</div>   | DANFOSS       |
| 101/151                  | <div style="display: inline-block; border: 1px solid black; padding: 2px;">CTW</div> <div style="display: inline-block; border: 1px solid black; padding: 2px; margin-left: 5px;">MRV</div> <div style="display: inline-block; border: 1px solid black; padding: 2px; margin-left: 5px;">PCD1</div> <div style="display: inline-block; border: 1px solid black; padding: 2px; margin-left: 5px;">PCD2</div> | <div style="display: inline-block; border: 1px solid black; padding: 2px;">STW</div> <div style="display: inline-block; border: 1px solid black; padding: 2px; margin-left: 5px;">MAV</div> <div style="display: inline-block; border: 1px solid black; padding: 2px; margin-left: 5px;">PCD1</div> <div style="display: inline-block; border: 1px solid black; padding: 2px; margin-left: 5px;">PCD2</div> | DANFOSS       |

195NA211.10

#### ■ Control Word and Status Word under Instance 20/70

Set parameter 904 *PPO type* to select Instance 20/70 [12].

The control word in Instance 20 is defined as following:

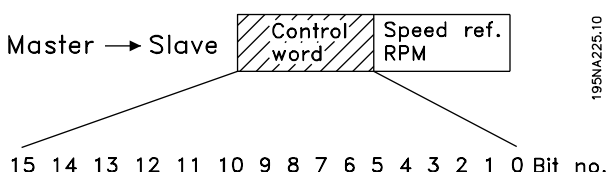

195NA225.10

| Bit     | Bit = 0                 | Bit = 1                 |
|---------|-------------------------|-------------------------|
| 00      | Stop                    | Run Fwd.                |
| 01      | Reserved for future use | Reserved for future use |
| 02      | No function             | Fault reset             |
| 03 - 15 | Reserved for future use | Reserved for future use |

##### Bit 0, Run Fwd:

Bit 0 = "0" means that the VLT frequency converter has a stop command.

Bit 0 = "1" leads to a start command and the VLT frequency converter will start to run the motor.

##### Bit 2, Fault Reset

Bit 0 = "0" means that there is no reset of a trip.

Bit 0 = "1" means that a trip is reset.

Regarding the Speed reference, see section *Bus speed reference value, under Instance 20/70 and 21/71.*

The status word in Instance 70 is defined as following:

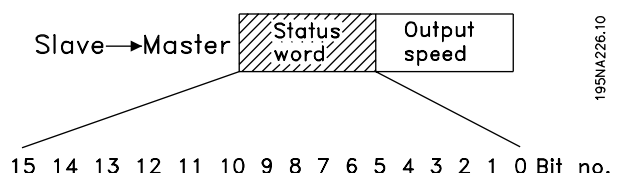

195NA226.10

| Bit     | Bit = 0                 | Bit = 1                 |
|---------|-------------------------|-------------------------|
| 00      | No fault                | Trip                    |
| 01      | Reserved for future use | Reserved for future use |
| 02      | Not running             | Running                 |
| 03 - 15 | Reserved for future use | Reserved for future use |

##### Bit 0, Fault:

Bit 0 = "0" means that there is no fault on the VLT frequency converter.

Bit 0 = "1" means that there is a fault on the VLT frequency converter.

##### Bit 2, Running

Bit 0 = "0" means that there is no active start command. Bit 0 = "1" means that there is an active start command.

Regarding the Actual output speed, see section *Actual output speed, under Instance 20/70 and 21/71.*

### ■ Control Word and Status Word under Instance 21/71

Set parameter 904 *PPO type 1* to select Instance 21/71 [13].

The control word in Instance 21 is defined as following:

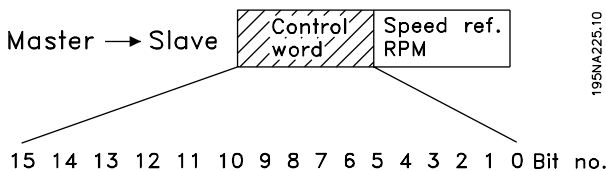

| Bit | Bit = 0     | Bit = 1     |
|-----|-------------|-------------|
| 00  | Stop        | Run Fwd     |
| 01  | Stop        | Run Rev     |
| 02  | No function | Fault reset |
| 03  |             |             |
| 04  |             |             |
| 05  |             | Net Ctrl    |
| 06  |             | Net Ref     |
| 07  | -           |             |
| 15  |             |             |

#### Bit 0, Run Fwd:

Bit 0 = "0" means that the VLT frequency converter has a stop command.

Bit 0 = "1" leads to a start command and the VLT frequency converter will start to run the motor clockwise.

#### Bit 1, Run Rev:

Bit 0 = "0" leads to a stop of the motor.

Bit 0 = "1" leads to a start of the motor.

#### Bit 2, Fault Reset:

Bit 0 = "0" means that there is no reset of a trip.

Bit 0 = "1" means that a trip is reset.

#### Bit 5, Net Ref:



#### NB!

Please note, that a change will have an effect on parameter 502 - 506.

#### Bit 6, Net Ctrl:



#### NB!

Please note, that a change will have an effect on parameter 214, 305, 307, 308 and 314.

Regarding the Speed reference, see section *Bus speed reference value, under Instance 20/70 and 21/71.*

The status word in Instance 71 is defined as following:

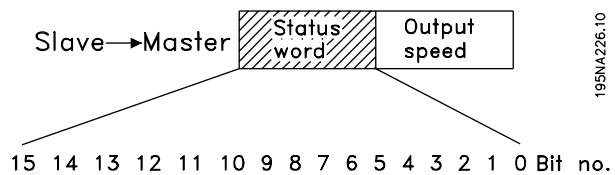

| Bit | Bit = 0           | Bit = 1        |
|-----|-------------------|----------------|
| 00  |                   | Trip           |
| 01  |                   | Warning        |
| 02  |                   | Running 1 Fwd  |
| 03  |                   | Running 2 Rev. |
| 04  |                   | Ready          |
| 05  |                   | Crtl from Net  |
| 06  |                   | Ref from Net   |
| 07  |                   | At reference   |
| 08  | - State Attribute |                |
| 15  |                   |                |

#### Bit 0, Fault:

Bit 0 = "0" means that there is no fault on the VLT frequency converter.

Bit 0 = "1" means that there is a fault on the VLT frequency converter.

#### Bit 1, Warning:

Bit 0 = "0" means that there is no unusual situation.

Bit 0 = "1" means that an abnormal condition has arisen .

#### Bit 2, Running 1:

Bit 2 = "0" means that the drive is not in one of these states or that Run 1 is not set.

Bit 2 = "1" means that the drive state attribute is enabled or stopping , or that Fault-Stop and bit 0 (Run 1) of the CTW is set at the same time.

#### Bit 3, Running 2:

Bit 3 = "0" means means, that the drive is not in one of these states or that Run 2 is not set.

Bit 3 = "1" means that the drive state attribute is enabled or stopping , or that fault-stop and bit 0 (Run 2) of the CTW is set at the same time.

#### Bit 4, Ready:

Bit 4 = "0" means that the state attribute is in another state.

Bit 4 = "1" means that the state attribute is ready or enabled or stopping.

195NA226.10

195NA225.10

**Bit 5, Control from net:**

Bit 5 = "0" means that the drive is controlled from the standard inputs.

Bit 5 = "1" means that Devicenet has the control (start, stop, reverse) of the drive.

**Bit 6, Ref from Net:**

Bit 6 = "0" means that the reference comes from the drive's inputs.

Bit 6 = "1" means that the reference is coming from Devicenet.

**Bit 7, At reference:**

Bit 7 = "0" means that the motor is running, but that the present speed is different from the preset speed reference, i.e. while the speed is being ramped up/down during start/stop.

Bit 7 = "1" means that the drive's speed equals the reference.

**Bit 8 - 15, State attribute:**

Represents the state attribute of the drive, as indicated in the following table:

| Number | Meaning           |
|--------|-------------------|
| 0      | (Vendor specific) |
| 1      | Startup           |
| 2      | Not ready         |
| 3      | Ready             |
| 4      | Enabled           |
| 5      | Stopping          |
| 6      | Fault stop        |
| 7      | Faulted           |

Regarding the Actual output speed, see section *Actual output speed, under Instance 20/70 and 21/71*

■ **Bus speed reference value, under Instance 20/70 and 21/71**

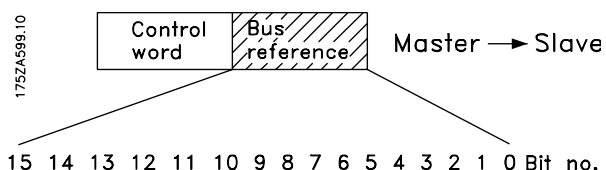

The speed reference value is transmitted to the VLT frequency converter in the form of a 16-bit word. The value is transmitted as a whole number. (Negative figures are formatted by means of 2's complement.)

The bus speed reference has the following format:

Parameter 203 = "0" ["ref<sub>MIN</sub> • ref<sub>MAX</sub>"]

0 (0000 Hex) [RPM] • + 32767 (7FFF Hex) [RPM]

Parameter 203 = "1" [- ref<sub>MAX</sub> • + ref<sub>MAX</sub>"]

-32767 (8000 Hex) • +32767 [RPM] (7FFF Hex)

The actual reference [Ref. %] in the VLT depends on the settings, in the following parameters:

- 104 Motor frequency
- 106 Motor Nom. speed
- 205 Max. Reference

Note that, If the bus speed reference is negative, and the control word contains a run reverse signal, the drive runs clockwise.

■ **Actual output speed, under Instance 20/70 and 21/71**

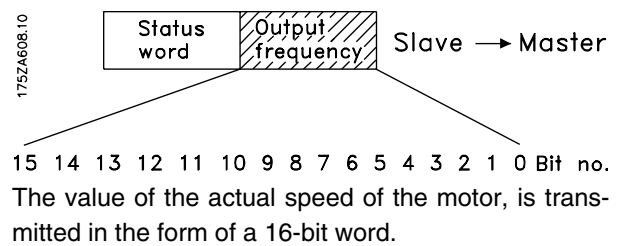

The value of the actual speed of the motor, is transmitted in the form of a 16-bit word.

The value is transmitted as a whole number. (Negative figures are formed by means of 2's complement.)

The actual speed value has the following format:  
-32767 (8000 Hex) [RPM] • +32767 [RPM] (7FFF Hex) [RPM]

■ **Control Word and Status Word under Instance 100/150 and 101/151**

Set parameter 904 *PPO type 1* [10] to select Instance 100/150.

The control word in Instance 100/101 is defined as following:

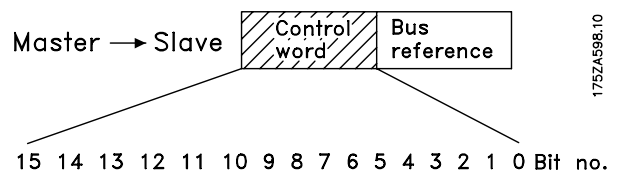



| Bit | Bit = 0            | Bit =1          |
|-----|--------------------|-----------------|
| 00  |                    | Preset ref. lsb |
| 01  |                    | Preset ref. msb |
| 02  | DC braking         |                 |
| 03  | Coasting stop      |                 |
| 04  | Quick stop         |                 |
| 05  | Freeze outp. freq. |                 |
| 06  | Ramp stop          | Start           |
| 07  |                    | Reset           |
| 08  |                    | Jog             |
| 09  | Ramp 1             | Ramp 2          |
| 10  | Data not valid     | Data valid      |
| 11  | No function        |                 |
| 12  | No function        |                 |
| 13  | Select Setup, lsb  |                 |
| 14  | Select Setup, msb  |                 |
| 15  |                    | Reversing       |

### Bit 00/01:

Bit 00/01 is used to select between the two pre-programmed references (parameters 215-218 *Preset reference*) according to the following table:

| Preset ref. | Parameter | Bit 01 | Bit 00 |
|-------------|-----------|--------|--------|
| 1           | 215       | 0      | 0      |
| 2           | 216       | 0      | 1      |
| 3           | 217       | 1      | 0      |
| 4           | 218       | 1      | 1      |



### NB!

In parameter 508 *Selection of preset reference* a selection is made to define how Bit 00/01 gates with the corresponding function on the digital inputs.

### Bit 02, DC brake:

Bit 02 = '0' causes DC braking and stop. Brake voltage and duration are preset in parameters 132 *DC brake voltage* and parameter 126 *DC braking time*. Note: In parameter 504 *DC brake* a selection is made to define how Bit 02 gates with the corresponding function on a digital input.

### Bit 03, Coasting stop:

Bit 03 = '0' causes the frequency converter to immediately "let go" of the motor (the output transistors are "shut off"), so that it coasts to a standstill.

Bit 03 = '1' causes the frequency converter to be able start the motor if the other starting conditions have been fulfilled. Note: In parameter 502 *Coasting stop* a selection is made to define how Bit 03 gates with the corresponding function on a digital input.

### Bit 04, Quick stop:

Bit 04 = '0' causes a stop, in which the motor's speed is ramped down to stop via parameter 212 *Quick stop ramp-down time*.

### Bit 05, Freeze output frequency:

Bit 05 = '0' causes the present output frequency (in Hz) to freeze. The frozen output frequency can now only be changed by means of the digital inputs programmed to *Speed up* and *Speed down*.



### NB!

If *Freeze output* is active, the frequency converter cannot be stopped via Bit 06 *Start* or via a digital input. The frequency converter can only be stopped by the following:

- Bit 03 Coasting stop
- Bit 02 DC braking
- Digital input programmed to *DC braking*, *Coasting stop* or *Reset and coasting stop*.

### Bit 06, Ramp stop/start:

Bit 06 = '0' causes a stop, in which the motor's speed is ramped down to stop via the selected *ramp down* parameter.

Bit 06 = '1' causes the frequency converter to be able to start the motor, if the other starting conditions have been fulfilled. Note: In parameter 505 *Start* a selection is made to define how Bit 06 Ramp stop/start gates with the corresponding function on a digital input.

### Bit 07, Reset:

Bit 07 = '0' does not cause a reset.

Bit 07 = '1' causes the reset of a trip. Reset is activated on the signal's leading edge, i.e. when changing from logic '0' to logic '1'.

### Bit 08, Jog:

Bit 08 = '1' causes the output frequency to be determined by parameter 213 *Jog frequency*.

### Bit 09, Selection of ramp 1/2:

Bit 09 = "0" means that ramp 1 is active (parameters 207/208). Bit 09 = "1" means that ramp 2 (parameters 209/210) is active.

### Bit 10, Data not valid/Data valid:

Is used to tell the frequency converter whether the control word is to be used or ignored. Bit 10 = '0' causes the control word to be ignored, Bit 10 = '1' causes the control word to be used. This function is relevant, because the control word is always contained in the telegram, regardless of which type of telegram is used, i.e. it is possible to turn off the control word if you do not wish to use it in connection with updating or reading parameters.

### Bit 11, No function:

Bit 11 has no function.

### Bit 12, No function:

Bit 12 has no function.

### Bit 13/14, Selection of Setup:

Bits 13 and 14 are used to choose from the four menu Setups according to the following table:

| Setup | Bit 14 | Bit 13 |
|-------|--------|--------|
| 1     | 0      | 0      |
| 2     | 0      | 1      |
| 3     | 1      | 0      |
| 4     | 1      | 1      |

The function is only possible when *Multi-Setups* is selected in parameter 004 *Active Setup*.

Note: In parameter 507 *Selection of Setup* a selection is made to define how Bit 13/14 gates with the corresponding function on the digital inputs.

### Bit 15 Reversing:

Bit 15 = '0' causes no reversing.

Bit 15 = '1' causes reversing.

Note: In the factory setting reversing is set to *digital* in parameter 506 *Reversing*. Bit 15 only causes reversing when either *Ser. communication*, *Logic or* or *Logic and* is selected.

The Status Word in Instance 150/151 is defined as following:

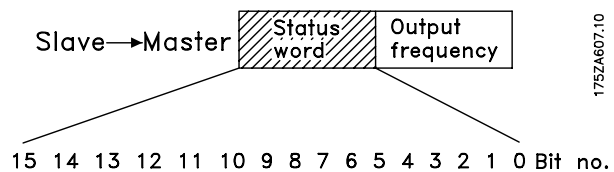

| Bit | Bit = 0                 | Bit = 1            |
|-----|-------------------------|--------------------|
| 00  |                         | Control ready      |
| 01  |                         | Drive ready        |
| 02  | Coasting stop           |                    |
| 03  | No trip                 | Trip               |
| 04  | Not used                |                    |
| 05  | Not used                |                    |
| 06  | Not used                |                    |
| 07  | No warning              | Warning            |
| 08  | Speed • ref.            | Speed = ref.       |
| 09  | Local control           | Ser. communi.      |
| 10  | Outside frequency range | Frequency limit OK |
| 11  |                         | Motor running      |
| 12  |                         |                    |
| 13  |                         | Voltage warn.      |
| 14  |                         | Current limit      |
| 15  |                         | Thermal warn.      |

### Bit 00, Control ready:

Bit 00 = '1'. The frequency converter is ready for operation.

Bit 00 = '0'. The frequency converter is not ready for operation.

### Bit 01, Drive ready:

Bit 01 = '1'. The frequency converter is ready for operation, but there is an active coasting command via the digital inputs or via serial communication.

### Bit 02, Coasting stop:

Bit 02 = '0'. The frequency converter has released the motor.

Bit 02 = '1'. The frequency converter can start the motor when a start command is given.

### Bit 03, No trip/trip:

Bit 03 = '0' means that the frequency converter is not in fault mode.

Bit 03 = '1' means that the frequency converter is tripped, and that it needs a reset signal for operation to be reestablished.

### Bit 04, Not used:

Bit 04 is not used in the status word.

### Bit 05, Not used:

Bit 05 is not used in the status word.

### Bit 06, Not used:

Bit 06 is not used in the status word.

### Bit 07, No warning/warning:

Bit 07 = '0' means that there are no warnings.

Bit 07 = '1' means that a warning has occurred.

### Bit 08, Speed• ref/speed = ref.:

Bit 08 = '0' means that the motor is running, but that the present speed is different from the preset speed reference. It might, for example, be the case while the speed is being ramped up/down during start/stop.

Bit 08 = '1' means that the motor's present speed is the same as the preset speed reference.

### Bit 09, Local operation/serial communication control:

Bit 09 = '0' means that [STOP/RESET] is activated on the control unit, or that *Local control* in parameter 002 *Local/remote operation* is selected. It is not possible to control the frequency converter via serial communication.

Bit 09 = '1' means that it is possible to control the frequency converter via serial communication.

### Bit 10, Outside frequency range:

Bit 10 = '0', if the output frequency has reached the value in parameter 201 *Output frequency low limit* or parameter 202 *Output frequency high limit*. Bit 10 = "1" means that the output frequency is within the defined limits.

### Bit 11, Running/not running:

Bit 11 = '0' means that the motor is not running.

Bit 11 = '1' means that the frequency converter has a start signal or that the output frequency is greater than 0 Hz.

### Bit 13, Voltage warning high/low:

Bit 13 = '0' means that there are no voltage warnings.

Bit 13 = '1' means that the DC voltage in the frequency converter's intermediate circuit is too low or too high.

### Bit 14, Current limit:

Bit 14 = '0' means that the output current is less than the value in parameter 221 *Current Limit*  $I_{LIM}$ .

Bit 14 = '1' means that the output current is greater than the value in parameter 221 *Current Limit*  $I_{LIM}$  and that the frequency converter will trip after a set period of time.

### Bit 15, Thermal warning:

Bit 15 = '0' means that there is no thermal warning.

Bit 15 = '1' means that the temperature limit has been exceeded in either the motor, frequency converter or from a thermistor that is connected to a digital input.

### ■ Bus reference value

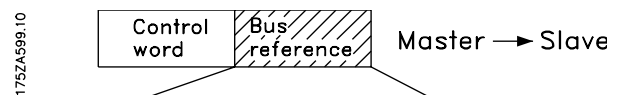

175ZA698.10

15 14 13 12 11 10 9 8 7 6 5 4 3 2 1 0 Bit no.

The frequency reference value is transmitted to the VLT frequency converter in the form of a 16-bit word. The value is transmitted as a whole number (-32767 • 32767). (Negative figures are formatted by means of 2's complement.)

The bus reference has the following format:

Parameter 203 = "0" ["refMIN • refMAX"]

0 • 16384 (4000 Hex) ~ 0 • 100% ~ "refMIN • refMAX"

Parameter 203 = "1" [- refMAX • + refMAX]

- 16384 (C000 Hex) • + 16384 (4000 Hex) ~

- 100% • + 100% ~ - refMAX • + refMAX

### ■ Actual output frequency

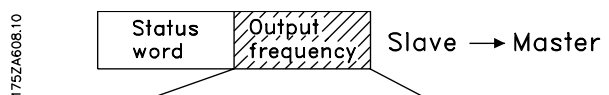

175ZA608.10

15 14 13 12 11 10 9 8 7 6 5 4 3 2 1 0 Bit no.

The value of the actual output frequency of the VLT frequency converter, is transmitted in the form of a 16-bit word. The value is transmitted as a whole number (-32767 • 32767) (Negative figures are formed by means of 2's complement).

The actual output frequency has the following format:

-32767 • +32767.

-16384 (C000 Hex) corresponds to -100%, and 16384 (4000 Hex) corresponds to 100%.

### ■ Process Data, PCD

The VLT 2800/FCD 300 DeviceNet offers a flexible way for the user to customize the number of Process Data (I/O words) and the functionality of each word. To activate the user definable Process data the user has to select the I/O Instance 101/151 in parameter 904 *PPO selection*. This will change the I/O size to four words in the input and output area. This selection uses the Danfoss specific profile for the Control-/Status word as well for the Main Reference Value/Main Actual Value.

The first two words are fixed on the VLT 2800/FCD 300 DeviceNet, whereas the input and output PCD1 and PCD2 can be selected by the user. The number of PCD's active in a SYSTEM is fixed to 2 words.



### NB!

The changing of Parameter 904 *PPO selection* is first active at the next powerup, and it may change the mapping of the Masters (PC/PLC).

To enable the use of PCD data of the VLT 2800/FCD 300 DeviceNet the contents of each single PCD word has to be configured in Parameter 915 *PCD write configuration* and 916 *PCD read configuration*. Changing Parameter 915/916 has immediately effect on the PCD data.

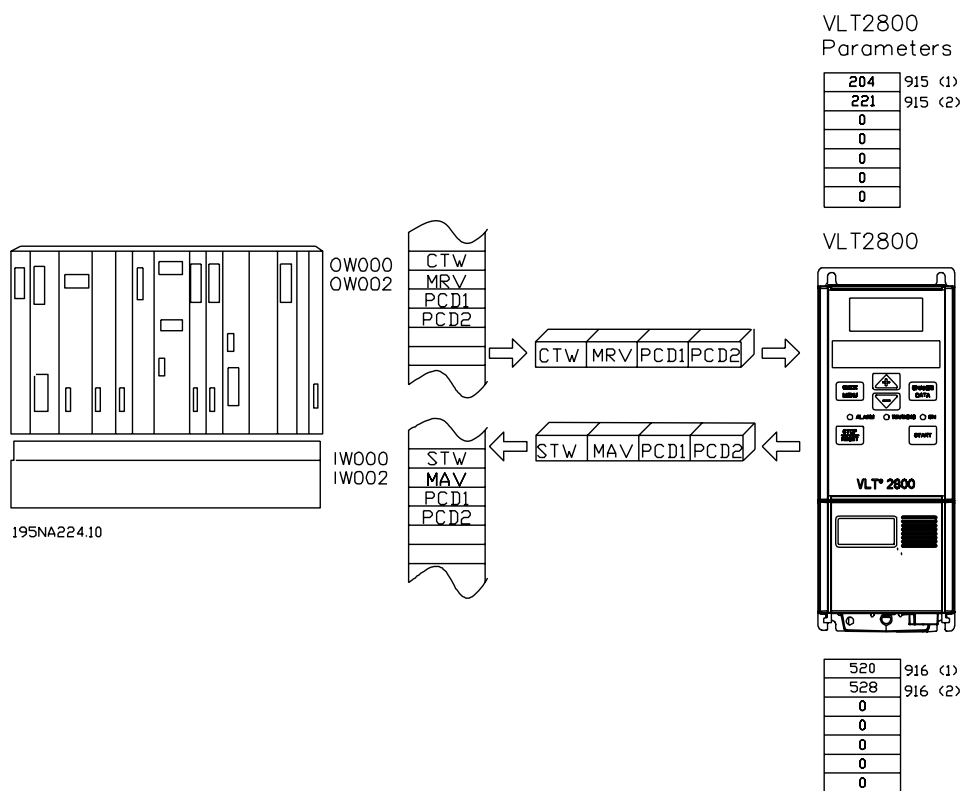

■ DeviceNet object classes

■ Class Code 0x01

For Class Code 0x01, the following Identity Instance Attributes have been implemented:

| Attribute | Access  | Name               | Datatype | Min/Max                                 | Units | Default | Description                          |
|-----------|---------|--------------------|----------|---|-------|---------|--------------------------------------|
| 1         | Get     | Vendor             | USINT    |   |       | 97      | Danfoss Drives Vendor Code           |
| 2         | Get     | Device Type        | UINT     |   |       | 2       | AC/DC Motor                          |
| 3         | Get     | Product Code       | UINT     | 200 - 399 VLT 2800<br>400 - 499 FCD 300 |       |         | See EDS File section                 |
| 4         | Get     | Revision           | UINT     |   |       |         | Software version on VLT 2800/FCD 300 |
| 5         | Get     | Status             | UINT     |   |       |         |                                      |
| 6         | Get     | Serial number      | UDINT    |   |       |         | From VLT 2800/FCD 300                |
| 7         | Get     | Product Name       | String   |   |       |         | VLT 2800/FCD 300                     |
| 10        | Get/Set | Heartbeat Interval | USINT    |   |       |         |                                      |

■ Class Code 0x02

For Class Code 0x02, the following Message Router Instance Attributes have been implemented:

| Attribute | Access | Name              | Datatype | Min/Max | Units | Default | Description |
|-----------|--------|-------------------|----------|---------|-------|---------|-------------|
| 1         | Get    | Number of classes | USINT    |         |       |         |             |

■ Class Code 0x03

For Class Code 0x03, the following DeviceNet Objects have been implemented:

| Attribute | Access  | Name                                  | Datatype | Min/Max | Units | Default | Description   |
|-----------|---------|---------------------------------------|----------|---------|-------|---------|---|
| 1         | Get/Set | MAC ID                                | USINT    | 0-63    |       | 63      | Node address  |
| 2         | Get/Set | Baud Rate                             | USINT    | 0-2     |       | 0       | 0 = 125<br>1 = 250<br>2 = 500                                     |
| 3         | Get/Set | BOI                                   | BOOL     |         |       |         | Bus-Off Interrupt   |
| 5         | Get     | Allocate Information                  |          |         |       |         | Only required if predefined Master/Slave is implemented           |
| 6         | Get     | MAC ID Switch changed                 | BOOL     | 0-1     |       | 0       | The Node address Switch has changed since the last power-up/reset |
| 7         | Get     | Baud Rate switched from last power up | BOOL     | 0-1     |       | 0       | The Baud Rate Switch has changed since the last power-up/reset    |

■ Class Code 0x04

For Class Code 0x04, the following Assembly Object Instances have been implemented:

| Attribute | Access | Name | Datatype | Min/Max | Units | Default | Description |
|-----------|--------|------|----------|---------|-------|---------|-------------|
| 3         | Set    | Data | ARRAY    |         |       |         |             |

| Attribute | Access | Datasize | Description                    |
|-----------|--------|----------|--------------------------------|
| 20        | Set    | 2 Words  | DeviceNet AC/DC Profile        |
| 21        | Set    | 2 Words  | DeviceNet AC/DC Profile        |
| 70        | Get    | 2 Words  | DeviceNet AC/DC Profile        |
| 71        | Get    | 2 Words  | DeviceNet AC/DC Profile        |
| 100       | Set    | 2 Words  | Danfoss specific, no PCD Words |
| 101       | Set    | 4 Words  | Danfoss specific, 2 PCD Words  |
| 150       | Get    | 2 Words  | Danfoss specific, no PCD Words |
| 151       | Get    | 4 Words  | Danfoss specific, 2 PCD Words  |

**■ Class Code 0x05**

For Class Code 0x05, the following Connection Object Attributes have been implemented:

**Instance 1 Attributes: Explicit Message Instance**

| Attribute | Access  | Name                                  | Datatype       | Description  |
|-----------|---------|---------------------------------------|----------------|--|
| 1         | Get     | State                                 | USINT          | State of the object  |
| 2         | Get     | Instance Type                         | USINT          | Indicates either I/O or Messages Connection  |
| 3         | Get     | Transport Class Trigger               | USINT          | Defines behaviour of the Connection  |
| 4         | Get     | Produced Connection ID                | UINT           | CAN Identifier Field when the Connection transmits   |
| 5         | Get     | Consumed Connection ID                | UINT           | AN Identifier Field value that denotes message to be received  |
| 6         | Get     | Initial Communication Characteristics | USINT          | Defines the message group(s) across which productions and consumptions associated with this Connection occur |
| 7         | Get     | Produced Connection size              | UINT           | Maximum number of bytes transmitted across this Connection   |
| 8         | Get     | Consumed Connection size              | UINT           | Maximum number of bytes received across this Connection  |
| 9         | Get/Set | Expected Package                      | UINT           | Defines timing associated with this Connection   |
| 12        | Get     | Watchdog timeout action               | USINT          | Defines how to handle Inactivity/Watchdog timeout  |
| 13        | Get     | Produced Connection Path Length       | UINT           | Number of Bytes in the produced connection path attribute  |
| 14        | Get     | Produced Connection Path              | Array of USINT | Specifies the Application Object(s) whose data is to be produced by these Connection Objects                 |
| 15        | Get     | Consumed Connection Path Length       | UINT           | Number of bytes in the consumed connection path attribute  |
| 16        | Get     | Consumed Connection Path              | Array of USINT | Specifies the Application object(s) that are to receive the data consumed by this Connection object          |
| 17        | Get     | Production Inhibit Time               | UINT           | Defines minimum time between new data production. This attribute is required for I/O Client connection       |

**Instance 2 Attributes: Polled I/O**

| Attribute | Access  | Name                                  | Datatype       | Description  |
|-----------|---------|---------------------------------------|----------------|--|
| 1         | Get     | State                                 | USINT          | State of the object  |
| 2         | Get     | Instance Type                         | USINT          | Indicates either I/O or Messages Connection  |
| 3         | Get     | Transport Class Trigger               | USINT          | Defines behaviour of the Connection  |
| 4         | Get     | Produced Connection ID                | UINT           | CAN Identifier Field when the Connection transmits   |
| 5         | Get     | Consumed Connection ID                | UINT           | AN Identifier Field value that denotes message to be received  |
| 6         | Get     | Initial Communication Characteristics | USINT          | Defines the message group(s) across which productions and consumptions associated with this Connection occur |
| 7         | Get     | Produced Connection size              | UINT           | Maximum number of bytes transmitted across this Connection   |
| 8         | Get     | Consumed Connection size              | UINT           | Maximum number of bytes received across this Connection  |
| 9         | Get/Set | Expected Package                      | UINT           | Defines timing associated with this Connection   |
| 12        | Get     | Watchdog timeout action               | USINT          | Defines how to handle Inactivity/Watchdog timeout  |
| 13        | Get     | Produced Connection Path Length       | UINT           | Number of Bytes in the produced connection path attribute  |
| 14        | Get     | Produced Connection Path              | Array of USINT | Specifies the Application Object(s) whose data is to be produced by these Connection Objects                 |
| 15        | Get     | Consumed Connection Path Length       | UINT           | Number of bytes in the consumed connection path attribute  |
| 16        | Get     | Consumed Connection Path              | Array of USINT | Specifies the Application object(s) that are to receive the data consumed by this Connection object          |
| 17        | Get     | Production Inhibit Time               | UINT           | Defines minimum time between new data production. This attribute is required for I/O Client connection       |

**Instance 3: Bit Strobe**

| Attribute | Access  | Name                                  | Datatype       | Description  |
|-----------|---------|---------------------------------------|----------------|--|
| 1         | Get     | State                                 | USINT          | State of the object  |
| 2         | Get     | Instance Type                         | USINT          | Indicates either I/O or Messages Connection  |
| 3         | Get     | Transport Class Trigger               | USINT          | Defines behaviour of the Connection  |
| 4         | Get     | Produced Connection ID                | UINT           | CAN Identifier Field when the Connection transmits   |
| 5         | Get     | Consumed Connection ID                | UINT           | AN Identifier Field value that denotes message to be received  |
| 6         | Get     | Initial Communication Characteristics | USINT          | Defines the message group(s) across which productions and consumptions associated with this Connection occur |
| 7         | Get     | Produced Connection size              | UINT           | Maximum number of bytes transmitted across this Connection   |
| 8         | Get     | Consumed Connection size              | UINT           | Maximum number of bytes received across this Connection  |
| 9         | Get/Set | Expected Package                      | UINT           | Defines timing associated with this Connection   |
| 12        | Get     | Watchdog timeout action               | USINT          | Defines how to handle Inactivity/Watchdog timeout  |
| 13        | Get     | Produced Connection Path Length       | UINT           | Number of Bytes in the produced connection path attribute  |
| 14        | Get     | Produced Connection Path              | Array of USINT | Specifies the Application Object(s) whose data is to be produced by these Connection Objects                 |
| 15        | Get     | Consumed Connection Path Length       | UINT           | Number of bytes in the consumed connection path attribute  |
| 16        | Get     | Consumed Connection Path              | Array of USINT | Specifies the Application object(s) that are to receive the data consumed by this Connection object          |
| 17        | Get     | Production Inhibit Time               | UINT           | Defines minimum time between new data production. This attribute is required for I/O Client connection       |

**Instance 4: Change of State/Cycle**

| Attribute | Access  | Name                                  | Datatype       | Description  |
|-----------|---------|---------------------------------------|----------------|--|
| 1         | Get     | State                                 | USINT          | State of the object  |
| 2         | Get     | Instance Type                         | USINT          | Indicates either I/O or Messages Connection  |
| 3         | Get     | Transport Class Trigger               | USINT          | Defines behaviour of the Connection  |
| 4         | Get     | Produced Connection ID                | UINT           | CAN Identifier Field when the Connection transmits   |
| 5         | Get     | Consumed Connection ID                | UINT           | AN Identifier Field value that denotes message to be received  |
| 6         | Get     | Initial Communication Characteristics | USINT          | Defines the message group(s) across which productions and consumptions associated with this Connection occur |
| 7         | Get     | Produced Connection size              | UINT           | Maximum number of bytes transmitted across this Connection   |
| 8         | Get     | Consumed Connection size              | UINT           | Maximum number of bytes received across this Connection  |
| 9         | Get/Set | Expected Package                      | UINT           | Defines timing associated with this Connection   |
| 12        | Get     | Watchdog timeout action               | USINT          | Defines how to handle Inactivity/Watchdog timeout  |
| 13        | Get     | Produced Connection Path Length       | UINT           | Number of Bytes in the produced connection path attribute  |
| 14        | Get     | Produced Connection Path              | Array of USINT | Specifies the Application Object(s) whose data is to be produced by these Connection Objects                 |
| 15        | Get     | Consumed Connection Path Length       | UINT           | Number of bytes in the consumed connection path attribute  |
| 16        | Get     | Consumed Connection Path              | Array of USINT | Specifies the Application object(s) that are to receive the data consumed by this Connection object          |
| 17        | Get     | Production Inhibit Time               | UINT           | Defines minimum time between new data production. This attribute is required for I/O Client connection       |

**■ Class Code 0x28**

For Class Code 0x28, the following Motor Data Instance Attributes have been implemented:

| Attribute | Access  | Name            | Datatype | Min/Max   | Units  | Default      | Description  |
|-----------|---------|-----------------|----------|-----------|--------|--------------|--|
| 3         | Get/Set | MotorType       | USINT    | 0-10      |        | 7            | 0 = Non Standard Motor<br>1 = PM DC Motor<br>2 = FC DC Motor<br>3 = PM Synchronous Motor<br>4 = FC Synchronous Motor<br>5 = Switched Reluctance Motor<br>6 = Wound Rotor Induction Motor<br>7 = Squirrel Cage Induction Motor<br>8 = Stepper Motor<br>9 = Sinusoidal PM BL Motor<br>10 = Trapezoidal PM BL Motor |
| 6         | Get/Set | Rated Current   | UNIT     | 0-100.00  | 100 mA | Drive depend | Rates Stator Current<br>(from Motor nameplate)   |
| 7         | Get/Set | Rated Voltage   | UNIT     | 200-500   | Volt   | Drive depend | Rated Base Voltage<br>(from Motor nameplate)   |
| 8         | Get/Set | Rated power     | UDINT    | 0-18500   | Watt   | Drive depend | Rated Power at Rated Frequency   |
| 9         | Get/Set | Rated Frequency | UNIT     | 1-1000    | Hz     | Drive depend | Rated Elec. Frequency<br>(from Motor nameplate)  |
| 15        | Get/Set | Base Speed      | UNIT     | 100-60000 | RPM    | Drive depend | Nominal Motor speed<br>(from Motor nameplate)  |

**■ Class Code 0x29**

For Class Code 0x29, the following Control Supervisory Instance Attributes have been implemented:

| Attribute | Access  | Name          | Datatype | Min/Max | Default | Description  |
|-----------|---------|---------------|----------|---------|---------|--|
| 3         | Get/Set | Run 1         | Bool     | 0-1     |         | Run Fwd, see note below  |
| 4         | Get/Set | Run 2         | Bool     | 0-1     |         | Run rev, see note below  |
| 5         | Get/Set | NetCtrl       | Bool     | 0-1     | 1       | 0 = Local Control<br>1 = Control from Network  |
| 6         | Get     | State         | USINT    | 0-7     |         | 0 = Vendor Specific<br>1 = Startup<br>2 = Not ready<br>3 = Ready<br>4 = Enabled<br>5 = Stopping<br>6 = Fault Stop<br>7 = Fault |
| 7         | Get     | Running 1     | Bool     | 0-1     | 0       | 0 = Other State<br>1 = (Enable and Run 1) or<br>(Stopping and Running 1) or<br>(Fault stop and Running 1)                      |
| 8         | Get     | Running 2     | Bool     | 0-1     | 0       | 0 = Other State<br>1 = (Enable and Run 2) or<br>(Stopping and Running 2) or<br>(Fault stop and Running 2)                      |
| 9         | Get     | Ready         | Bool     | 0-1     |         | 0 = Other State<br>1 = Ready or Enabled or Stopping  |
| 10        | Get     | Fault         | Bool     | 0-1     |         | 0 = No Faults Present<br>1 = Fault Occured (latched)   |
| 12        | Get/Set | Fault Rst     | Bool     | 0-1     | 0       | 0 = No Action<br>0 * 1 = Reset Fault   |
| 13        | Get     | Fault Code    | UINT     |         |         |  |
| 15        | Get     | Crt From Net  | Bool     | 0-1     | 1       | 0 = Control is local<br>1 = Control is from Network  |
| 16        | Get/Set | DN Fault Mode | USINT    | 0-2     | 1       | Action on loss of DeviceNet<br>0 = Fault + Stop<br>1 = Ignore (Warning Optional)<br>2 = Danfoss specific                       |

AC drive profile is only available if selecting Instance  
20/70 or 21/71



**■ Class Code 0x2A**

For Class Code 0x2A, the following AC/DC Drive Instance Attributes have been implemented:

| Attribute | Access  | Name         | Datatype | Min/Max    | Default                        | Description   |
|-----------|---------|--------------|----------|------------|--------------------------------|---|
| 3         | Get     | At Reference | Bool     | 0-1        |                                | 0 = Drive not at reference<br>1 = Drive actual at reference   |
| 4         | Get/Set | Net Ref      | Bool     | 0-1        | 1                              | 0 = Set reference not DN Control<br>1 = Set Reference at DN Control   |
| 6         | Get/Set | Drive Mode   | USINT    | 0-5        | 1                              | 0 = Vendor specific mode<br>1 = Open loop speed (Frequency)<br>2 = Closed loop speed control<br>3 = Torque control<br>4 = Process control (e.g. PI)<br>5 = Position control |
| 7         | Get     | Speed Actual | INT      |            | RPM / 2 <sup>Speed Scale</sup> | Actual drive speed (best approximation)   |
| 8         | Get/Set | Speed Ref    | INT      |            | RPM / 2 <sup>Speed Scale</sup> | Speed Reference   |
| 22        | Get/Set | Speed Scale  | SINT     | -128 - 127 |                                | Speed scaling factor  |
| 29        | Get     | Ref from Net | Bool     | 0-1        |                                | 0 = Local speed reference<br>1 = DeviceNet speed reference  |

## VLT® 2800/FCD 300 DeviceNet

### ■ Danfoss Classes

|                     |           |
|---------------------|-----------|
| Parameter 001 - 099 | Class 100 |
| Parameter 101 - 199 | Class 101 |
| Parameter 200 - 299 | Class 102 |
| Parameter 300 - 399 | Class 103 |
| Parameter 400 - 499 | Class 104 |
| Parameter 500 - 599 | Class 105 |
| Parameter 600 - 699 | Class 106 |
| Parameter 700 - 799 | Class 107 |
| Parameter 800 - 899 | Class 108 |
| Parameter 900 - 999 | Class 109 |
| Index Pointer       | Class 120 |

| Class   | Instance | Attribute | Variable |
|---------|----------|-----------|----------|
| 109 Dec | 1 Dec    | 116 Dec   | 518 Dec  |
| 6D Hex  | 1 Hex    | 74 Hex    | 206 hex  |

#### Instance Description:

The Danfoss VLT 2800/FCD 300 DeviceNet only use Instance 1, so always leave this at the value of 1.

#### Attribute Description:

The attributes for the VLT 2800/FCD 300 parameter are the last 2 (two) digits of the parameter + 100.

#### Example:

The parameter 529 (Analog input, terminal 53) will have the following:

|           |     |
|-----------|-----|
| Class     | 105 |
| Instance  | 1   |
| Attribute | 129 |

#### Reading/writing to parameters with index:

Parameters of type indexed (e.g. 915 & 916) need special handling since DeviceNet does not support indexed addressing.

The way to handle this in the VLT 2800/FCD 300, is by using the the Danfoss Class 120. which serves as an index pointer. The pointer has to be set up before every read/write of an indexed parameter.



#### NB!

If two masters are accessing this feature at the same ime, wrong data may occur.

#### Example:

Write 518 in index 2 in parameter 916 *PCD Read*:

First setup the index pointer in class 120. In this example index 2:

| Class   | Instance | Attribute | Variable |
|---------|----------|-----------|----------|
| 120 Dec | 1 Dec    | 100 Dec   | 2 Dec    |
| 78 Hex  | 1 Hex    | 64 Hex    | 2 hex    |

Next step is to write the data (in this example 518) to parameter 916 *PCD Read*

### ■ DeviceNet Operation Mode

#### ■ Bit Strobe

Bit strobe provides the ability of a slave to react to a special command of the master in a defined way. Master sends the Bit strobe command to many devices at a time, only one bit of the message is assigned to a single slave at a time, what means, that only the state "TRUE" or "FALSE" can be transmitted.

This parameter may be used for synchronizing drives. Executing the Bit-Strobe command with a value of "1" (TRUE) leads the addressed drive to ignore the input values of the control word and the reference transmitted via the Assembly Instances, the Control

Supervisor and the AC/DC Drive Object. If the Bit-Strobe command is executed with a value of "0" (FALSE), the drive reacts according to the input values again. This means, that the value of the Bit-Strobe command is stored internally and the drive reacts according the value of the Bit-Strobe command. The master can transmit the new reference when the Bit-Strobe value is "1", it must be valid after the execution of the Bit-Strobe command with the value "0" [10]. After a Bit-Strobe command has been executed, the device must answer with the according I/O telegram and ignore any CTW, MAV and PCDs transmitted by the master.

DeviceNet Operation Mode

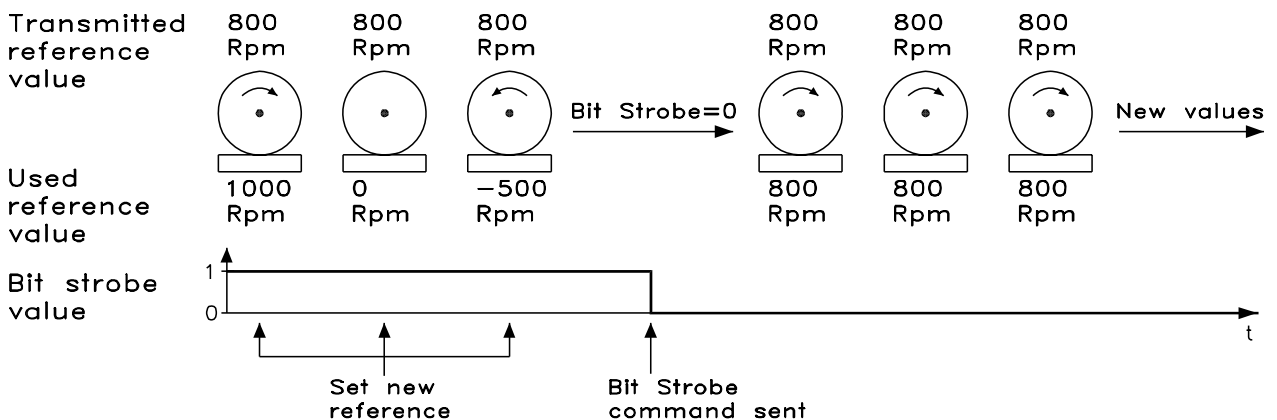
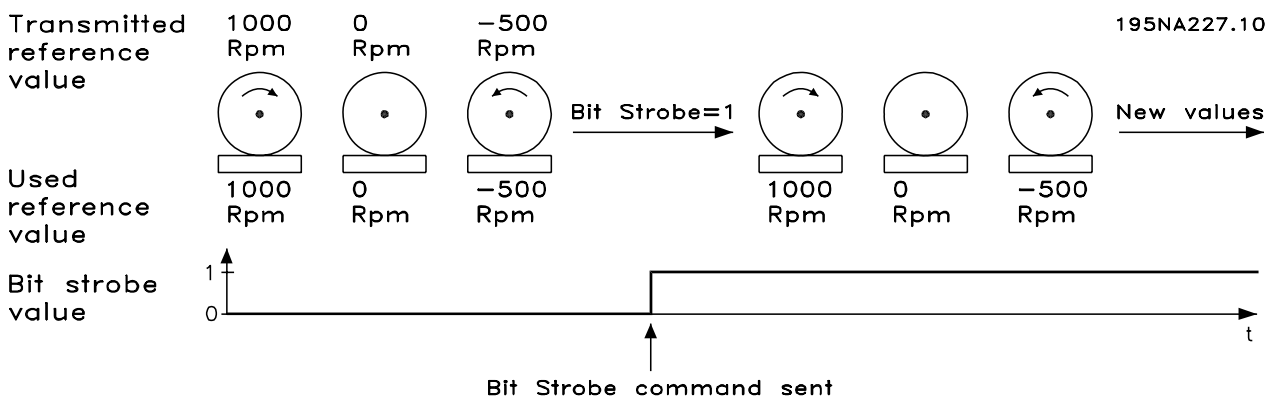

### ■ Polling

This is the standard Devicenet operation mode, meaning that data can be acquired by the master via polling using the Devicenet or Danfoss objects.

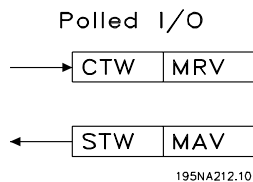

### ■ Change of State, COS

This operation modus can be used in order to minimize network traffic. Messages are only sent to the consumer, if a defined state or value has changed. In order to signalize, that the connection has not been crashed or is powered off, a Heartbeat Message is transmitted within a specified time (Heartbeat Interval). This time is defined in attribute heartbeat time of the connection object class code 0x05. To prevent the device from producing heavy network traffic, if a value often changes, the Production Inhibit Time (attribute of connection object) is defined. This parameter defines the minimum delay between 2 c-o-s messages.

The Attribute Expected Package Rate defines the maximum time between two Cos messages even though the value has not changed. Cos operation modus can only be used on I/O instances defined in parameter 904.

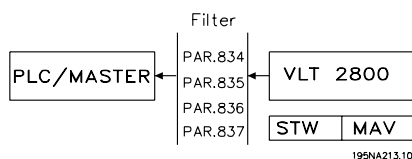
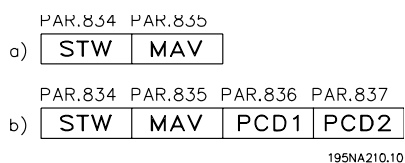

Parameters 834 through 837 can be used for filtering out undesired events for Cos. If a filter bit is set to 0, the corresponding I/O instance bit will not be able to produce a Cos message.

## VLT® 2800/FCD 300 DeviceNet

### ■ EDS Files

Note that the EDS files can be uploaded from the VLT frequency converters via RS Networkx. Before uploading the EDS file you must check the version of RS Networkx in Help and About RS Networkx. RS Networkx version 3.11.00 supports the format Errata 2 and no changes must be made to the VLT frequency converter. RS Networkx version 3.00.00 supports Errata 1 and parameter 838 *EDS Data type* must be set to Errata 1 and power must be re-cycle.

Start RS Networkx and go online and the VLT 2800/FCD 300 will be shown as a grey box as *unregistered device*. Click on the VLT 2800/FCD 300 and go to *Tools* and choose *EDS Wizard*. Click on next by the EDS wizard and choose *Create an EDS file*. RS Networkx will now start to create an EDS file from the VLT frequency converter.

To upload EDS files please visit [www.DanfossDrives.com](http://www.DanfossDrives.com)

#### VLT 2800 US version with DeviceNet

| Product Code | Drive Model | Drive Rating<br>kW (HP) | Voltage     | EDS File Name |
|--------------|-------------|-------------------------|-------------|---------------|
| 232          | VLT 2803    | 0.37 (0.50)             | 200 - 240 V |               |
| 233          | VLT 2805    | 0.55 (0.75)             | 200 - 240 V |               |
| 234          | VLT 2807    | 0.75 (1.00)             | 200 - 240 V |               |
| 235          | VLT 2811    | 1.10 (1.50)             | 200 - 240 V |               |
| 236          | VLT 2815    | 1.50 (2.00)             | 200 - 240 V |               |
| 237          | VLT 2822    | 2.20 (3.00)             | 200 - 240 V |               |
| 238          | VLT 2830    | 3.70 (5.00)             | 200 - 240 V |               |
| 283          | VLT 2805    | 0.55 (0.75)             | 380 - 480 V |               |
| 284          | VLT 2807    | 0.75 (1.00)             | 380 - 480 V |               |
| 285          | VLT 2811    | 1.10 (1.50)             | 380 - 480 V |               |
| 286          | VLT 2815    | 1.50 (2.00)             | 380 - 480 V |               |
| 287          | VLT 2822    | 2.20 (3.00)             | 380 - 480 V |               |
| 288          | VLT 2830    | 3.00 (4.00)             | 380 - 480 V |               |
| 289          | VLT 2840    | 4.00 (5.00)             | 380 - 480 V |               |
| 290          | VLT 2855    | 5.50 (7.50)             | 380 - 480 V |               |
| 291          | VLT 2875    | 7.50 (10.00)            | 380 - 480 V |               |
| 292          | VLT 2880    | 11.0 (15.00)            | 380 - 480 V |               |
| 293          | VLT 2881    | 15.0 (20.00)            | 380 - 480 V |               |
| 294          | VLT 2882    | 18.5 (25.00)            | 380 - 480 V |               |

#### VLT 2800 European version with DeviceNet

| Product Code | Drive Model | Drive Rating<br>kW (HP) | Voltage     | EDS File Name |
|--------------|-------------|-------------------------|-------------|---------------|
| 332          | VLT 2803    | 0.37 (0.50)             | 200 - 240 V |               |
| 333          | VLT 2805    | 0.55 (0.75)             | 200 - 240 V |               |
| 334          | VLT 2807    | 0.75 (1.00)             | 200 - 240 V |               |
| 335          | VLT 2811    | 1.10 (1.50)             | 200 - 240 V |               |
| 336          | VLT 2815    | 1.50 (2.00)             | 200 - 240 V |               |
| 337          | VLT 2822    | 2.20 (3.00)             | 200 - 240 V |               |
| 338          | VLT 2830    | 3.70 (5.00)             | 200 - 240 V |               |
| 383          | VLT 2805    | 0.55 (0.75)             | 380 - 480 V |               |
| 384          | VLT 2807    | 0.75 (1.00)             | 380 - 480 V |               |
| 385          | VLT 2811    | 1.10 (1.50)             | 380 - 480 V |               |
| 386          | VLT 2815    | 1.50 (2.00)             | 380 - 480 V |               |
| 387          | VLT 2822    | 2.20 (3.00)             | 380 - 480 V |               |
| 388          | VLT 2830    | 3.00 (4.00)             | 380 - 480 V |               |
| 389          | VLT 2840    | 4.00 (5.00)             | 380 - 480 V |               |
| 390          | VLT 2855    | 5.50 (7.50)             | 380 - 480 V |               |
| 391          | VLT 2875    | 7.50 (10.00)            | 380 - 480 V |               |
| 392          | VLT 2880    | 11.0 (15.00)            | 380 - 480 V |               |
| 393          | VLT 2881    | 15.0 (20.00)            | 380 - 480 V |               |
| 394          | VLT 2882    | 18.5 (25.00)            | 380 - 480 V |               |

#### FCD 300 European version with DeviceNet

| Product Code | Drive Model | Drive Rating<br>kW (HP) | Voltage     | EDS File Name |
|--------------|-------------|-------------------------|-------------|---------------|
| 480          | FCD 303     | 0.37 (0.50)             | 380 - 480 V |               |
| 481          | FCD 305     | 0.55 (0.75)             | 380 - 480 V |               |
| 482          | FCD 307     | 0.75 (1.00)             | 380 - 480 V |               |
| 483          | FCD 311     | 1.10 (1.50)             | 380 - 480 V |               |
| 484          | FCD 315     | 1.50 (2.00)             | 380 - 480 V |               |
| 485          | FCD 322     | 2.20 (3.00)             | 380 - 480 V |               |
| 486          | FCD 330     | 3.00 (4.00)             | 380 - 480 V |               |

### Special Attention



#### NB!

Please note, that terminal 46 has been removed from the VLT 2800 DeviceNet card, meaning that parameter 341 - 342 are not having any function.

- 002:

If operation site = Local, then control via DeviceNet is not possible.

- 502-508:

Selection of how to gate DeviceNet control commands with control commands on the digital inputs of the control card.

- 515-538:

Data read out parameters that can be used to read various actual data from the VLT, as for example actual status on the analog and digital inputs of the control card thus using these as inputs to the master.

- 800 *Protocol Select*

Select DeviceNet in this parameter.

- 801 *Baud rate select*

Selection of DeviceNet transmission speed.

- 833 *Fieldbus enable*

Enable the DeviceNet communication. The default setting is disable.

- 904 *PPO selection*

Selection of Instance type.

- 918 *Station address / MAC ID*

Set the Station address / MAC ID in this parameter.

| 620                                   | Operation Mode |
|---------------------------------------|----------------|
| (OPERATION MODE)                      |                |
| <b>Value:</b>                         |                |
| ★ Normal operation (NORMAL OPERATION) | [0]            |
| Control card test (CONTROL CARD TEST) | [2]            |
| Initialize (INITIALIZE)               | [3]            |

#### Function:

In addition to its normal function, this parameter can be used to test the control card.

There is also the opportunity to perform an initialisation at the factory setting for all parameters in all Setups, with the exception of parameters 500 *Address*, 501 *Baudrate*, 600-605 *Operating data* and 615-617 *Fault log*.

#### Description of choice:

For FCD 300 connections see FCD 300 Design Guide MG.04.AX.YY par. 620.

Normal function [0] is used for normal operation of the motor.

Control card test [2] is selected if you wish to check the control card's analog/digital input, analog/digital outputs, relay outputs and 10 V and 24 V voltages.

The test is performed as follows:

18, 27, 33 are connected to relay terminal 03.

19, 29, V+ are connected to relay terminal 02.

50 - 53 are connected.

42 - 60 are connected.

55 - V- are connected.

12 is connected to relay terminal 01.

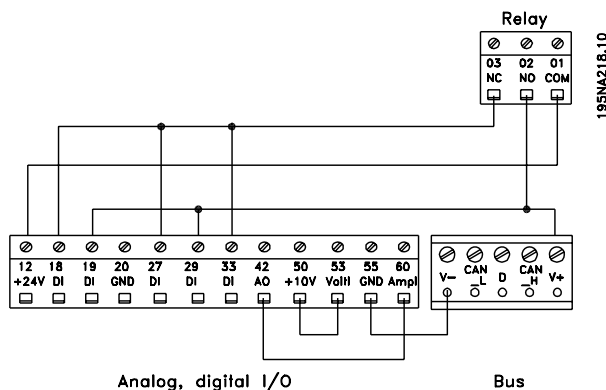

Use the following procedure for the control card test:

1. Select control card test.
2. Disconnect the mains voltage and wait until the light in the display has disappeared.
3. Mount according to drawing and description.
4. Connect the mains voltage.
5. The frequency converter automatically undertakes a test of the control card.

If the frequency converter displays a fault code from 37-45, the control card test has failed. Replace the control card to start up the frequency converter.

If the frequency converter comes into Display mode, the test is OK. Remove the test connector and the frequency converter is ready for operation. Parameter 620 *Operating mode* is automatically set to *Normal operation* [0].

*Initialisation* [3] is selected if you wish to use the unit's factory setting.

Procedure for initialisation:

1. Select *Initialisation* [3].

## VLT® 2800/FCD 300 DeviceNet

2. Disconnect the mains voltage and wait until the light in the display has disappeared.
3. Connect the mains voltage.
4. An initialisation is performed in all parameters in all Setups, with the exception of parameters 500 *Address*, 501 *Baudrate*, 600-605 *Operating data*, 615-617 *Fault log*, 833 *Fieldbus enable* and 904 *PPO selection*.

parameter, the function selected in parameter 804 *Response after bus error* will be activated.

### Description of choice:

Set the desired time.

Please note, that when the drive is running Cyclic or COS mode, the Bus time out has to be set higher than Heartbeat Rate. If not, the VLT will time out.

### 800 Protocol Select

(Protocol Select)

Value:

- ★ DeviceNet (DeviceNet) [2]

### Function:

This parameter is read only.

### 801 Baud Rate Select

(Baud Rate Select)

Value:

- ★ 125 kbps (125 kbps) [20]
- 250 kbps (250 kbps) [21]
- 500 kbps (500 kbps) [22]

### Function:

Selection of the DeviceNet transmission speed. It must correspond to the transmission speed of the master and the other DeviceNet nodes.

### Description of choice:

Select the baud rate.



### NB!

Note that a change of this parameter is first executed at next power up.

### 803 Bus time out

(bus time out)

Value:

- 1 - 99 sec ★ 1 sec

### Function:

If the VLT frequency converter doesn't receive a control word for a period longer than the time set in this

### 804 Bus time out function

(time out funct.)

Value:

- ★ OFF (off) [0]
- Freeze output frequency (freeze output) [1]
- Stop with auto restart (stop) [2]
- Output = jog frequency (jogging) [3]
- Output = max speed (max speed) [4]
- Stop with trip (stop and trip) [5]
- Select Setup 2 (select setup 2) [8]

### Function:

The timeout counter is activated at the first receipt of a valid control word, i.e. bit 10 = OK.

### Description of choice:

The VLT remains in the timeout status until one of the following four conditions occurs.

1. A valid control word (bit 10 = OK) is received and control via DeviceNet is resumed with the current control word. If the timeout function *Stop with trip* is selected a reset via bus, terminals or control panel is necessary.
2. Parameter 002 = Local operation => local control through control panel is active.
3. Parameter 804 = Off => control via DeviceNet is resumed, with the control word used last being taken.

### 805 Bit 10 function

(bit 10 function)

Function:

This parameter is read only.





## VLT® 2800/FCD 300 DeviceNet

### Description of choice:

Setup the filter mask for PCD 2.

### 838 EDS Data Types (EDS Data Types)

#### Value:

- Errata 1 (errata 1) [0]
- ★ Errata 2 (Errata 2) [1]

#### Function:

In this parameter it is possible to select between two data types when uploading an EDS file from the VLT frequency converter. The current versions of the configuration tools like DeviceNet Manager and RS Networkx can only handle data type Errata 1.

### Description of choice:

Select Errata 1 if DeviceNet Manager or RS Networkx version 3.00 is used.

Select Errata 2 if DeviceNet Manager or RS Networkx version 3.11 or higher is used.

### 839 EDS Product code (EDS Product code)

#### Value:

- ★ Power dependent [0]
- Power independent [1]

#### Function:

In this parameter it is possible to set the VLT 2800/FCD 300 to one Product code.

### Description of choice:

Power dependent: The Product code in each power range is different as shown in the section *EDS Files*.  
Power independent: The Product code in each power range is the same and only one EDS file can be used. Note that by this choice the EDS file cannot be uploaded from the Drive. The Power independent EDS file is available on [www.danfoss.com/drives](http://www.danfoss.com/drives).

### 850 Readout Transmit Error Counter (R.out.tr.err.co.)

#### Function:

This parameter is a read out of the *Transmit Error Counter* of the CAN controller since the last power up.

### 851 Readout Receive Error Counter (r.out.re.err.co.)

#### Function:

This parameter is a read out of the *Receive Error Counter* of the CAN controller since the last power up.

### 852 Readout Bus Off Counter (r.out.bus.off.co)

#### Function:

This parameter is a read out of the how many Bus Off events there has been since the last power up.

### 860 Controlword (Controlword)

#### Function:

This parameter is a read out of the VLT frequency Control word. This parameter can only be read via standard bus or DeviceNet and is not available via LCP.

### 861 Reference Value (Reference Value)

#### Function:

This parameter is a read out of the VLT frequency Reference value in the range 0 - 4000 Hex. This parameter can only be read via standard bus or DeviceNet and is not available via LCP.

### 880 Statusword (Statusword)

#### Function:

This parameter is a read out of the VLT frequency Status word. This parameter can only be read via standard bus or DeviceNet and is not available via LCP.

### 881 Main Actual Value (Main Actual Val.)

#### Function:

This parameter is a read out of the VLT frequency Main Actual Value in the range of 0 - 4000 Hex. This pa-

★ = factory setting, () = display text, [] = value for use in communication via serial communication port



---

**VLT® 2800/FCD 300 DeviceNet**

---

parameter can only be read via standard bus or DeviceNet and is not available via LCP.

---

### 904 PPO selection (ppo type select)

#### Value:

|                                       |      |
|---------------------------------------|------|
| Instance 20/70 (INSTANCE 20/70)       | [10] |
| Instance 21/71 (INSTANCE 21/71)       | [11] |
| ★ Instance 100/150 (Instance 100/150) | [12] |
| Instance 101/151 (INSTANCE 101/151)   | [13] |

#### Function:

This parameter allows to select between four different instances for the data transmission.

Instances 100/150 and 101/151 is a Danfoss specific instance and instance 20/70 and 21/71 is a ODVA specific AC Drive profile.

See also *Drive profile* in this manual for further information.



#### NB!

Note that a change of this parameter is first executed at next power up.

#### Description of choice:

Instance 100/150 use 2 words - one word for the control word and one word for the reference. See the control word in *Control word and Status word under instance 100/150* in this manual.

Instance 101/151 use 4 words - one word for the control word and one word for the reference. The last two words (PCD1 and PCD2) are user definable where it is possible to read and write to parameters via I/O communication. By using PCD to read data from parameters in the VLT it will be must quicker update than explicit message.

See the control word in *Control word and Status word under instance 100/150* in this manual

Instance 20/70 use 2 words - one word for the control word and one word for the reference. See the control word in *Control word and Status word under instance 20/70* in this manual.

Instance 21/71 use 2 words - one word for the control word and one word for the reference. See the control word in *Control word and Status word under instance 21/71* in this manual.



#### NB!

Note that AC Drive profile is only available if selecting Instance 20/70 or 21/71.

### 915 PCD write configuration (pcd config write)

#### Value:

|                     |                    |
|---------------------|--------------------|
| Sub index 1 (PCD 1) | [Parameter number] |
| Sub index 2 (PCD 2) | [Parameter number] |

#### Function:

Different parameters can be assigned to PCD 1-2 if instance 101/151 is selected in parameter 904 *PPO Selection*. The values in PCD 1-2 will be written to the selected parameters in the form of data values.

#### Description of choice:

The sequence of the subindexes corresponds to the sequence of the PCD in the PPO, i.e. subindex 1 = PCD 1, subindex 2 = PCD 2 etc. Each subindex may contain the number of any VLT parameter.

Note that subindex 3 - 8 are having no function.

### 916 PCD read configuration (pcd config read)

#### Value:

|                     |                    |
|---------------------|--------------------|
| Sub index 1 (PCD 1) | [Parameter number] |
| Sub index 2 (PCD 2) | [Parameter number] |

#### Function:

Different parameters can be assigned to PCD 1-2 if instance 101/151 is selected in parameter 904 *PPO Selection*. The values in PCD 1-2 will be read from the selected parameters in the form of data values.

#### Description of choice:

The sequence of subindices corresponds to the sequence of the PCD in the PPO, i.e. subindex 1 = PCD 1, subindex 2 = PCD 2 etc. Each subindex may contain the number of any VLT parameter.

Note that subindex 3 - 8 are having no function.

### 918 Station address/MAC ID (station address)

#### Value:

0 - 63 ★ 63

#### Function:

Every station connected to the same DeviceNet network must have an unambiguous address.

### Description of choice:

Set a unique address for each VLT 2800/FCD 300 that are connected to the same DeviceNet network.



#### NB!

Note that a change of this parameter is first executed at next power up.

### 953 Warning messages

(warning param.)

#### Value:

0 - FFFF Hex

#### Function:

In this parameter it is possible to read out warning messages via standard bus or DeviceNet. This parameter is not available via LCP, but the warning message can be seen by choosing *Com warning word* as display readout.

A bit is assigned to every warning (see the following list).

| Bit | Status   |
|-----|--|
| 0   | Bus not active (only if the bus has been active for at least once since last power-up) |
| 1   | Explicit connection timeout  |
| 2   | I/O connection timeout   |
| 3   | Error Passive Receive  |
| 4   | Error Warning Receive  |
| 5   | CAN bus off  |
| 6   | I/O send error   |
| 7   | Initialisation error   |
| 8   | No bus supply  |
| 9   | Bus reset  |
| 10  | Error Passive Transmit   |
| 11  | Error warning Transmit   |
| 12  | Duplicate MAC ID Error   |
| 13  | RX queue overrun   |
| 14  | TX queue overrun   |
| 15  | CAN overrun  |

Bus not active: means, that no bus communication is present or that the slave is not allocated.

Explicit connection timeout: This bit is set, if an explicit connection is timed out.

I/O connection timeout: This bit is set, if an I/O connection is timed out.

Error Passive Receive: This bit is set, if the CAN controller has reached it's error passive state for the message receiver.

Error Warning Receive: This bit is set, if the CAN controller has reached it's error warning state (more then 96 receive errors) for the message receiver.

CAN bus off: This bit is set, if CAN bus has been switched off, because a receive or Transmission Error Counter exceed a value of 255 or a bus off interrupt has occurred.

I/O send error: This bit is set, if an I/O send error has been detected.

Initialisation error: This bit is set, if the CAN controller has failed to initialize.

No bus supply: This bit is set, if the DN bus supply (normally 24 V) is not available. Only set, if DN option is active, and not, if CanOpen is active.

Bus reset: This bit is set, if the DN communication has been reset.

Error Passive Transmit: This bit is set, if the bus state error passive for the transmitter is reached. Please refer to chapter 5.8.

Error warning Transmit: This bit is set, if transmit error counter exceeds a value of 96, signaling that the bus may be seriously damaged.

Duplicate MAC ID Error: This bit is set, if duplicate MAC ID has been detected.

RX queue overrun: This bit is set, if receive data buffer has been overrun.

TX queue overrun: This bit is set, if transmit data buffer has been overrun

CAN overrun: This bit is set, if CAN data buffer has been overrun.

### 967 Control Word

(control word)

#### Value:

16 bit binary code

#### Function:

Parameter 967 is dedicated to sending a control word to the VLT frequency converter when using explicit message. This parameter is not available via LCP.

### 968 Status Word

(status word)

#### Value:

Read only (16 bit binary code)

### Function:

Parameter 968 is dedicated to read the status word from the VLT frequency converter when using explicit message. This parameter is not available via LCP.

### 970 Parameter setup selection (edit setup select)

#### Value:

|                                |     |
|--------------------------------|-----|
| Factory setting                | [0] |
| Parameter setup 1 (setup 1)    | [1] |
| Parameter setup 2 (setup 2)    | [2] |
| Parameter setup 3 (setup 3)    | [3] |
| Parameter setup 4 (setup 4)    | [4] |
| ★ Active set up (active setup) | [5] |

### Function:

Like parameter 005 (described in the product manual for the VLT 2800 series).

### Description of choice:

It is only possible to write to the active set-up via DeviceNet in the VLT 2800/FCD 300. This means that it is **not** possible to run for instance in set-up 1 and change data in set-up 2, 3 or 4.

### 971 Save date values (store data value)

#### Value:

|  |     |
|--|-----|
| ★ Not active (off)                     | [0] |
| Save active setup (store active setup) | [1] |
| Save edit setup (store edit setup)     | [2] |
| Save all setups (store all setups)     | [3] |
| Store always (store always)            | [4] |

### Function:

Parameter values modified through DeviceNet are only saved in RAM, i.e. the modifications are lost in the event of a power failure. This parameter is used to activate a function by means of which all parameter values are saved in EEPROM, preserving them even in the case of a power failure.

### Description of choice:

- *Not active:* The function is not active.
- *Save active setup:* All parameter setups of the active setup are saved in EEPROM. The val-

ue returns to Not active after all parameter values have been saved.

- *Save edit setup:* All parameter setups of the setup being processed are saved in EEPROM. The value returns to Not active after all parameter values have been saved.
- *Save all setups:* All parameter setups in all setups are saved in EEPROM. The value returns to Not active after all parameter values have been saved.
- *Store always:* Each parameter write request will automatically be stored in EEPROM.



### NB!

Please note that continuous writing via explicit message may damage the EEPROM.

### 980–982 Defined parameters (defined param.)

#### Value:

Read only

#### Function:

The three parameters contain a list of all parameters defined in the VLT. Each of the three parameters can be read as an array by means of an explicit message.

Each parameter contains up to 116 elements (parameter numbers). The number of parameters that are in use (980, 981 and 982) depends on the respective VLT configuration.

When a 0 is issued as a parameter number, the list ends.

### 990–992 Modified parameters (modifi. param.)

#### Value:

Read only

#### Function:

The three parameters contain a list of all parameters that have been changed from the factory setting. Every one of the three parameters can be read as an array with the help of the explicit read service. The subindices begin with 1 and follow the sequence of the parameter numbers. Each parameter contains up to 116 elements (parameter numbers). The number of pa-

Parameters that are in use (990, 991 and 992) depends on how many parameters have been modified in comparison with the factory setting.

Pure read parameters (Read only), such as data output parameters, are not logged as modified even if they are changing.

When a 0 is issued as a parameter number, the list ends.

---

**■ Warning and Alarm Messages**

There is a clear distinction between alarms and warnings. In the case of an alarm, The VLT will enter a fault condition. After the cause for the alarm has been cleared, the master will have to acknowledge the alarm message for the VLT to start operating again. A warning on the other hand may come when a warning condition appears, and disappear when conditions return to normal without interfering with the process.

---

**■ Warnings**

Any warning within the VLT is represented by a single bit within a warning word. A warning word is always an action parameter. Bit status FALSE [0] means no warning, while bit status TRUE [1] means warning. To each bit and each bit status there is a corresponding text string. In addition to the warning word message the master will also be notified through a change of bit 7 in the Status Word.

---

**■ Alarms**

Following an Alarm message the VLT will enter Fault condition. Only after the fault has been alleviated and the master has acknowledged the alarm message by setting bit 3 in the Control Word, can the VLT resume operation. Any warning within the VLT is represented by a single bit within a warning word. A warning word is always an action parameter. Bit status FALSE [0] means no fault, while bit status TRUE [1] means fault. To each bit and each bit status there is a corresponding text string.

---

■ **Abbreviations**

| English | Elaboration                                  |
|---------|--|
| CAN     | Controller Area Network                      |
| CTW     | Control Word                                 |
| COS     | Change of State                              |
| EDS     | Electronic Data Sheet                        |
| EMC     | Electromagnetic Compatibility                |
| FIFO    | First In First Out                           |
| HPFB    | High Performance Field Bus                   |
| IND     | Subindex                                     |
| I/O     | Input/Output                                 |
| ISO     | International Standards Organization         |
| LED     | Light Emiting Diode                          |
| LSB     | Least Significant Bit                        |
| MSB     | Most Significant Bit                         |
| MAV     | Main Actual Value                            |
| MRV     | Main Reference Value                         |
| OD      | Object Directory                             |
| IW      | Peripheral input word                        |
| QW      | Peripheral output word                       |
| PC      | Personal Computer                            |
| PCD     | Process Data                                 |
| PCP     | Peripherals Communication Protocol           |
| PDU     | Protocol Data Unit                           |
| PLC     | Programmable Logic Control                   |
| STW     | Status Word                                  |
| VDE     | Association of German Electrical Technicians |
| VDI     | Association of German Electrical Engineers   |
| VSD     | Variable Speed Drive                         |



**■ Factory settings - VLT 2800**

| PNU # | Parameterdescription         | Factory setting                | 4-setup | Conv. index | Data type |
|-------|------------------------------|--------------------------------|---------|-------------|-----------|
| 001   | Language                     | English                        | No      | 0           | 5         |
| 002   | Local/remote operation       | Remote-controlled              | Yes     | 0           | 5         |
| 003   | Local reference              | 000,000.000                    | Yes     | -3          | 4         |
| 004   | Active Setup                 | Setup 1                        | No      | 0           | 5         |
| 005   | Programming Setup            | Active Setup                   | No      | 0           | 5         |
| 006   | Setup copying                | No copying                     | No      | 0           | 5         |
| 007   | LCP copy                     | No copying                     | No      | 0           | 5         |
| 008   | Display scaling              | 1.00                           | Yes     | -2          | 6         |
| 009   | Large display readout        | Frequency [Hz]                 | Yes     | 0           | 5         |
| 010   | Small display line 1.1       | Reference [%]                  | Yes     | 0           | 5         |
| 011   | Small display line 1.2       | Motor current [A]              | Yes     | 0           | 5         |
| 012   | Small display line 1.3       | Power [kW]                     | Yes     | 0           | 5         |
| 013   | Local control                | Remote control<br>as par. 100  | Yes     | 0           | 5         |
| 014   | Local stop/reset             | Active                         | Yes     | 0           | 5         |
| 015   | Local jog                    | Not active                     | Yes     | 0           | 5         |
| 016   | Local reversing              | Not active                     | Yes     | 0           | 5         |
| 017   | Local reset of trip          | Active                         | Yes     | 0           | 5         |
| 018   | Data change lock             | Not locked                     | Yes     | 0           | 5         |
| 019   | Operating status at power up | Forced stop,<br>use saved ref. | Yes     | 0           | 5         |
| 020   | Lock for Hand mode           | Active                         | No      | 0           | 5         |
| 024   | User-defined Quick Menu      | Not active                     | No      | 0           | 5         |
| 025   | Quick Menu Setup             | 000                            | No      | 0           | 6         |

**4-Setup:**

'Yes' means that the parameter can be programmed individually in each of the four Setups, i.e. one single parameter can have four different data values. 'No' means that the data value will be the same in all Set-ups.

**Conversion index:**

This number refers to a conversion figure to be used when writing or reading via serial communication with a frequency converter.

See *Data character* in *Serial communication*.

**Data type:**

Data type shows the type and length of the telegram.

| Data type | Description               |
|-----------|---------------------------|
| 3         | Integer 16                |
| 4         | Integer 32                |
| 5         | Unsigned 8                |
| 6         | Unsigned 16               |
| 7         | Unsigned 32               |
| 9         | Text string <sup>1)</sup> |

1. Not accessible from DeviceNet.

**■ Factory settings - VLT 2800**

| PNU # | Parameterdescription                  | Factory setting           | 4-setup | Conv. index | Data type |
|-------|---------------------------------------|---------------------------|---------|-------------|-----------|
| 100   | Configuration                         | Speed reg., open loop     | Yes     | 0           | 5         |
| 101   | Torque characteristics                | Constant torque           | Yes     | 0           | 5         |
| 102   | Motor power $P_{M,N}$                 | depends on unit           | Yes     | 1           | 6         |
| 103   | Motor voltage $U_{M,N}$               | depends on unit           | Yes     | 0           | 6         |
| 104   | Motor frequency $f_{M,N}$             | 50 Hz                     | Yes     | -1          | 6         |
| 105   | Motor current $I_{M,N}$               | depends on motor selected | Yes     | -2          | 7         |
| 106   | Rated motor speed                     | depends on par. 102       | Yes     | 0           | 6         |
| 107   | Automatic motor adjustment            | Optimisation off          | Yes     | 0           | 5         |
| 108   | Stator resistance $R_S$               | depends on motor selected | Yes     | -3          | 7         |
| 109   | Stator reactance $X_S$                | depends on motor selected | Yes     | -2          | 7         |
| 119   | High start torque                     | 0.0 sec                   | Yes     | -1          | 5         |
| 120   | Start delay                           | 0.0 sec                   | Yes     | -1          | 5         |
| 121   | Start function                        | Coast in start del.       | Yes     | 0           | 5         |
| 122   | Function at stop                      | Coast                     | Yes     | 0           | 5         |
| 123   | Min. freq. for activation of par. 122 | 0.1 Hz                    | Yes     | -1          | 5         |
| 126   | DC braking time                       | 10 sec.                   | Yes     | -1          | 6         |
| 127   | DC brake engaging frequency           | OFF                       | Yes     | -2          | 6         |
| 128   | Thermal motor protection              | No protection             | Yes     | 0           | 5         |
| 130   | Start frequency                       | 0.0 Hz                    | Yes     | -1          | 5         |
| 131   | Voltage at start                      | 0.0 V                     | Yes     | -1          | 6         |
| 132   | DC brake voltage                      | 0%                        | Yes     | 0           | 5         |
| 133   | Start voltage                         | depends on unit           | Yes     | -2          | 6         |
| 134   | Load compensation                     | 100 %                     | Yes     | -1          | 6         |
| 135   | U/f-ratio                             | depends on unit           | Yes     | -2          | 6         |
| 136   | Slip compensation                     | 100 %                     | Yes     | -1          | 3         |
| 137   | DC hold voltage                       | 0 %                       | Yes     | 0           | 5         |
| 138   | Brake cut out value                   | 3.0 Hz                    | Yes     | -1          | 6         |
| 139   | Brake cut in frequency                | 3.0 Hz                    | Yes     | -1          | 6         |
| 140   | Current, minimum value                | 0 %                       | Yes     | 0           | 5         |
| 142   | Leak reactance                        | depends on motor selected | Yes     | -3          | 7         |
| 143   | Internal ventilator control           | Automatic                 | Yes     | 0           | 5         |
| 144   | AC brake factor                       | 1.30                      | Yes     | -2          | 5         |
| 146   | Reset voltage vector                  | Off                       | Yes     | 0           | 5         |

**■ Factory Settings - VLT 2800**

| PNU # | Parameter description                  | Factory setting          | 4-setup | Conv. index | Data type |
|-------|--|--------------------------|---------|-------------|-----------|
| 200   | Output frequency range                 | Clockwise only, 0-132 Hz | Yes     | 0           | 5         |
| 201   | Output frequency, low limit $f_{MIN}$  | 0.0 Hz                   | Yes     | -1          | 6         |
| 202   | Output frequency, high limit $f_{MAX}$ | 132 Hz                   | Yes     | -1          | 6         |
| 203   | Reference range                        | Min ref.-Max ref.        | Yes     | 0           | 5         |
| 204   | Minimum ref $Ref_{MIN}$                | 0.000 Hz                 | Yes     | -3          | 4         |
| 205   | Maximum ref $Ref_{MAX}$                | 50.000 Hz                | Yes     | -3          | 4         |
| 206   | Ramp type                              | Linear                   | Yes     | 0           | 5         |
| 207   | Ramp-up time 1                         | 3.00 sec.                | Yes     | -2          | 7         |
| 208   | Ramp-down time 1                       | 3.00 sec.                | Yes     | -2          | 7         |
| 209   | Ramp-up time 2                         | 3.00 sec.                | Yes     | -2          | 7         |
| 210   | Ramp-down time 2                       | 3.00 sec.                | Yes     | -2          | 7         |
| 211   | Jog ramp time                          | 3.00 sec.                | Yes     | -2          | 7         |
| 212   | Quick stop ramp-down time              | 3.00 sec.                | Yes     | -2          | 7         |
| 213   | Jog frequency                          | 10.0 Hz                  | Yes     | -1          | 6         |
| 214   | Reference function                     | Sum                      | Yes     | 0           | 5         |
| 215   | Preset reference 1                     | 0.00%                    | Yes     | -2          | 3         |
| 216   | Preset reference 2                     | 0.00%                    | Yes     | -2          | 3         |
| 217   | Preset reference 3                     | 0.00%                    | Yes     | -2          | 3         |
| 218   | Preset reference 4                     | 0.00%                    | Yes     | -2          | 3         |
| 219   | Catch up/slow down reference           | 0.00%                    | Yes     | -2          | 6         |
| 221   | Current limit                          | 160 %                    | Yes     | -1          | 6         |
| 223   | Warn. Low current                      | 0.0 A                    | Yes     | -1          | 6         |
| 224   | Warn. High current                     | $I_{MAX}$                | Yes     | -1          | 6         |
| 225   | Warn. Low frequency                    | 0.0 Hz                   | Yes     | -1          | 6         |
| 226   | Warn. High frequency                   | 132.0 Hz                 | Yes     | -1          | 6         |
| 227   | Warn. Low Feedback                     | -4000.000                | Yes     | -3          | 4         |
| 228   | Warn.High Feedback                     | 4000.000                 | Yes     | -3          | 4         |
| 229   | Frequency bypass, bandwidth            | 0 Hz (OFF)               | Yes     | 0           | 6         |
| 230   | Frequency bypass 1                     | 0.0 Hz                   | Yes     | -1          | 6         |
| 231   | Frequency bypass 2                     | 0.0 Hz                   | Yes     | -1          | 6         |

## VLT® 2800/FCD 300 DeviceNet

### ■ Factory settings - VLT 2800

| PNU # | Parameterdescription             | Factory setting         | 4-setup | Conv. index | Data type |
|-------|----------------------------------|-------------------------|---------|-------------|-----------|
| 302   | Digital input, term. 18          | Start                   | Yes     | 0           | 5         |
| 303   | Digital input, term. 19          | Reversing               | Yes     | 0           | 5         |
| 304   | Digital input, term. 27          | Reset and coast inverse | Yes     | 0           | 5         |
| 305   | Digital input, term. 29          | Jog                     | Yes     | 0           | 5         |
| 307   | Digital input, term. 33          | No function             | Yes     | 0           | 5         |
| 308   | Term. 53, analogue input voltage | Reference               | Yes     | 0           | 5         |
| 309   | Term. 53, min scaling            | 0.0 V                   | Yes     | -1          | 6         |
| 310   | Term. 53, max scaling            | 10.0 V                  | Yes     | -1          | 6         |
| 314   | Term. 60, analogue input current | No function             | Yes     | 0           | 5         |
| 315   | Term. 60, min scaling            | 0.0 mA                  | Yes     | -4          | 6         |
| 316   | Term. 60, max scaling            | 20.0 mA                 | Yes     | -4          | 6         |
| 317   | Time out                         | 10 sec.                 | Yes     | 0           | 5         |
| 318   | Function after timeout           | No function             | Yes     | 0           | 5         |
| 319   | Term. 42, analogue output        | 0- $I_{MAX}$ = 0-20 mA  | Yes     | 0           | 5         |
| 323   | Relay output                     | Control ready           | Yes     | 0           | 5         |
| 327   | Pulse ref./FB                    | 5000 Hz                 | Yes     | 0           | 7         |
| 341   | Term. 46 digital output          | Control ready           | Yes     | 0           | 5         |
| 342   | Term. 46 Max. pulse output       | 5000 Hz                 | Yes     | 0           | 6         |
| 343   | Precise stop function            | Normal ramp stop        | Yes     | 0           | 5         |
| 344   | Counter value                    | 100000 pulses           | Yes     | 0           | 7         |
| 349   | Speed comp delay                 | 10 ms                   | Yes     | -3          | 6         |

#### 4-Setup:

'Yes' means that the parameter can be programmed individually in each of the four Setups, i.e. one single parameter can have four different data values. No' means that the data value will be the same in all Setups.

#### Conversion index:

This number refers to a conversion figure to be used when writing or reading via serial communication with a frequency converter.

See *Data character* in *Serial communication*.

#### Data type:

Data type shows the type and length of the telegram.

| Data type | Description               |
|-----------|---------------------------|
| 3         | Integer 16                |
| 4         | Integer 32                |
| 5         | Unsigned 8                |
| 6         | Unsigned 16               |
| 7         | Unsigned 32               |
| 9         | Text string <sup>1)</sup> |

1. Not accessible from DeviceNet.

**■ Factory settings - VLT 2800**

| PNU # | Parameter description               | Factory setting      | 4-setup | Conv. index | Data type |
|-------|-------------------------------------|----------------------|---------|-------------|-----------|
| 400   | Brake function                      | Depends on unit type | No      | 0           | 5         |
| 405   | Reset function                      | Manual reset         | Yes     | 0           | 5         |
| 406   | Aut. restart time                   | 5 sec.               | Yes     | 0           | 5         |
| 409   | Trip delay overcurrent              | Off (61 sec.)        | Yes     | 0           | 5         |
| 411   | Switching frequency                 | 4.5 kHz              | Yes     | 0           | 6         |
| 412   | Var. carrier frequency              | No LC-filter         | Yes     | 0           | 5         |
| 413   | Overmodulation function             | On                   | Yes     | 0           | 5         |
| 414   | Min. feedback                       | 0.000                | Yes     | -3          | 4         |
| 415   | Max. feedback                       | 1500.000             | Yes     | -3          | 4         |
| 416   | Process units                       | No unit              | Yes     | 0           | 5         |
| 417   | Speed PID propor.ampl.              | 0.010                | Yes     | -3          | 6         |
| 418   | Speed PID intergra.                 | 100 ms               | Yes     | -5          | 7         |
| 419   | Speed PID differentiation time      | 20.00 ms             | Yes     | -5          | 7         |
| 420   | Speed PID diff. amplification limit | 5.0                  | Yes     | -1          | 6         |
| 421   | Speed PID lowpass filter            | 20 ms                | Yes     | -3          | 6         |
| 423   | U1 voltage                          | par. 103             | Yes     | -1          | 6         |
| 424   | F1 frequency                        | Par. 104             | Yes     | -1          | 6         |
| 425   | U2 voltage                          | par. 103             | Yes     | -1          | 6         |
| 426   | F2 frequency                        | par. 104             | Yes     | -1          | 6         |
| 427   | U3 voltage                          | par. 103             | Yes     | -1          | 6         |
| 428   | F3 frequency                        | par. 104             | Yes     | -1          | 6         |
| 437   | Proc. PID no/inv.                   | Normal               | Yes     | 0           | 5         |
| 438   | Proc. PID anti wind.                | Active               | Yes     | 0           | 5         |
| 439   | Proc. PID start frequency           | Par. 201             | Yes     | -1          | 6         |
| 440   | Proc. PID start proportional ampl.  | 0.01                 | Yes     | -2          | 6         |
| 441   | Proc. PID integration time          | Off (9999.99 s)      | Yes     | -2          | 7         |
| 442   | Proc. PID differentiation time      | Off (0.00 s).        | Yes     | -2          | 6         |
| 443   | Proc. PID diff. ampl. limit         | 5.0                  | Yes     | -1          | 6         |
| 444   | Proc. PID lowpass filter time       | 0.02 s               | Yes     | -2          | 6         |
| 445   | Flying start                        | Not possible         | Yes     | 0           | 5         |
| 451   | Speed PID feedforward factor        | 100%                 | Yes     | 0           | 6         |
| 452   | Controller range                    | 10 %                 | Yes     | -1          | 6         |
| 456   | Brake voltage reduce                | 0                    | Yes     | 0           | 5         |

**■ Factory settings - VLT 2800**

| PNU # | Parameterdescription                   | Factory setting | 4-setup | Conv. index | Data type |
|-------|--|-----------------|---------|-------------|-----------|
| 500   | Address                                | 1               | No      | 0           | 5         |
| 501   | Baudrate                               | 9600 Baud       | No      | 0           | 5         |
| 502   | Coasting stop                          | Logic or        | Yes     | 0           | 5         |
| 503   | Quick stop                             | Logic or        | Yes     | 0           | 5         |
| 504   | DC brake                               | Logic or        | Yes     | 0           | 5         |
| 505   | Start                                  | Logic or        | Yes     | 0           | 5         |
| 506   | Reversing                              | Logic or        | Yes     | 0           | 5         |
| 507   | Selection of Setup                     | Logic or        | Yes     | 0           | 5         |
| 508   | Selection of preset ref.               | Logic or        | Yes     | 0           | 5         |
| 509   | Bus jog 1                              | 10.0 Hz         | Yes     | -1          | 6         |
| 510   | Bus jog 2                              | 10.0 Hz         | Yes     | -1          | 6         |
| 512   | Telegram profile                       | FC protocol     | Yes     | 0           | 5         |
| 513   | Bus time interval                      | 1 sec.          | Yes     | 0           | 5         |
| 514   | Bus time interval function             | Off             | Yes     | 0           | 5         |
| 515   | Data readout: Reference %              |                 | No      | -1          | 3         |
| 516   | Data readout: Reference [unit]         |                 | No      | -3          | 4         |
| 517   | Data readout: Feedback [unit]          |                 | No      | -3          | 4         |
| 518   | Data readout: Frequency                |                 | No      | -1          | 3         |
| 519   | Data readout: Frequency x scaling      |                 | No      | -1          | 3         |
| 520   | Data readout: Motor current            |                 | No      | -2          | 7         |
| 521   | Data readout: Torque                   |                 | No      | -1          | 3         |
| 522   | Data readout: Power [kW]               |                 | No      | 1           | 7         |
| 523   | Data readout: Power [HP]               |                 | No      | -2          | 7         |
| 524   | Data readout: Motor voltage [V]        |                 | No      | -1          | 6         |
| 525   | Data readout: DC Link voltage          |                 | No      | 0           | 6         |
| 526   | Data readout: Motor thermal load       |                 | No      | 0           | 5         |
| 527   | Data readout: Inverter thermal load    |                 | No      | 0           | 5         |
| 528   | Data readout: Digital input            |                 | No      | 0           | 5         |
| 529   | Data readout: Analogue input, term. 53 |                 | No      | -1          | 5         |
| 531   | Data readout: Analogue input, term. 60 |                 | No      | -4          | 5         |
| 532   | Data readout: Pulse reference          |                 | No      | -1          | 7         |
| 533   | Data readout: External reference       |                 | No      | -1          | 6         |
| 534   | Data readout: Status word              |                 | No      | 0           | 6         |
| 537   | Data readout: Inverter temperature     |                 | No      | 0           | 5         |
| 538   | Data readout: Alarm word               |                 | No      | 0           | 7         |
| 539   | Data readout: Control word             |                 | No      | 0           | 6         |
| 540   | Data readout: Warning word             |                 | No      | 0           | 7         |
| 541   | Data readout: Extended status word     |                 | No      | 0           | 7         |
| 544   | Data readout: Pulse count              |                 | No      | 0           | 7         |

**■ Factory settings - VLT 2800**

| PNU # | Parameterdescription                             | Factory setting  | 4-setup | Conv. index | Data type |
|-------|--|------------------|---------|-------------|-----------|
| 600   | Operating hours                                  |                  | No      | 73          | 7         |
| 601   | Hours run  |                  | No      | 73          | 7         |
| 602   | kWh counter                                      |                  | No      | 2           | 7         |
| 603   | Number of cut ins                                |                  | No      | 0           | 6         |
| 604   | Number of overtemperatures                       |                  | No      | 0           | 6         |
| 605   | Number of overvoltages                           |                  | No      | 0           | 6         |
| 615   | Fault log: Error code                            |                  | No      | 0           | 5         |
| 616   | Fault log: Time                                  |                  | No      | 0           | 7         |
| 617   | Fault log: Value                                 |                  | No      | 0           | 3         |
| 618   | Reset of kWh counter                             | No reset         | No      | 0           | 7         |
| 619   | Reset of running hours counter                   | No reset         | No      | 0           | 5         |
| 620   | Operation mode                                   | Normal operation | No      | 0           | 5         |
| 621   | Nameplate: Unit type                             |                  | No      | 0           | 9         |
| 624   | Nameplate: Software version                      |                  | No      | 0           | 9         |
| 625   | Nameplate: LCP identification no.                |                  | No      | 0           | 9         |
| 626   | Nameplate: Database identification no.           |                  | No      | -2          | 9         |
| 627   | Nameplate: Power parts version                   |                  | No      | 0           | 9         |
| 628   | Nameplate: Application option type               |                  | No      | 0           | 9         |
| 630   | Nameplate: Communication option type             |                  | No      | 0           | 9         |
| 632   | Nameplate: BMC software identification           |                  | No      | 0           | 9         |
| 633   | Nameplate: Motor database identification         |                  | No      | 0           | 9         |
| 634   | Nameplate: Unit identification for communication |                  | No      | 0           | 9         |
| 635   | Nameplate: Software parts no.                    |                  | No      | 0           | 9         |
| 640   | Software version                                 |                  | No      | -2          | 6         |
| 641   | BMC software identification                      |                  | No      | -2          | 6         |
| 642   | Power card identification                        |                  | No      | -2          | 6         |

**4-Setup:**

'Yes' means that the parameter can be programmed individually in each of the four Setups, i.e. one single parameter can have four different data values. No' means that the data value will be the same in all Set-ups.

**Conversion index:**

This number refers to a conversion figure to be used when writing or reading via serial communication with a frequency converter.

See *Data character* in *Serial communication*.

**Data type:**

Data type shows the type and length of the telegram.

| Data type | Description               |
|-----------|---------------------------|
| 3         | Integer 16                |
| 4         | Integer 32                |
| 5         | Unsigned 8                |
| 6         | Unsigned 16               |
| 7         | Unsigned 32               |
| 9         | Text string <sup>1)</sup> |

1. Not accessible from DeviceNet.

## VLT® 2800/FCD 300 DeviceNet

### ■ Factory settings - VLT 2800

| PNU # | Parameter description            | Factory setting     | Changes during operation | 4-Setup | Conversion-index | Data Type    |
|-------|----------------------------------|---------------------|--------------------------|---------|------------------|--------------|
| 801   | Baud rate selection              | 125 kbps            | Yes                      | No      | 0                | 5            |
| 803   | Time after bus error             | 1 sec.              | Yes                      | No      | 0                | 5            |
| 804   | Response after bus error         | Off                 | Yes                      | No      | 0                | 5            |
| 805   | Function control word bit Bit 10 | Bit 10 = CTW active | Yes                      | No      | 0                | 5            |
| 832   | Bus Off Interrupt Behavior       | Hold Can            | Yes                      | No      | 0                | 5            |
| 833   | Fieldbus Enable 0                | Enabled             | No                       | No      | 0                | 5            |
| 834   | Filter Mask 1                    | 0000                | Yes                      | No      | 0                | 6            |
| 835   | Filter Mask 2                    | 0000                | Yes                      | No      | 0                | 6            |
| 836   | Filter Mask 3                    | 0000                | Yes                      | No      | 0                | 6            |
| 837   | Filter Mask 4                    | 0000                | Yes                      | No      | 0                | 6            |
| 838   | ESD Data type                    | Errata 2            | No                       | No      | 0                | 5            |
| 839   | EDS Product code                 | Power dependent     | NO                       | No      | 0                | 5            |
| 850   | Readout Transmit Error Counter   | 0                   | No                       | No      | 0                | 5            |
| 851   | Readout Receive Error Counter    | 0                   | No                       | No      | 0                | 5            |
| 852   | Readout Bus Off Counter          | 0                   | No                       | No      | 0                | 5            |
| 860   | Controlword                      | 0                   | Yes                      | No      | 0                | Bit sequence |
| 861   | Reference Value                  | 0                   | No                       | No      | 0                | Signed 16    |
| 880   | Statusword                       | 0                   | No                       | No      | 0                | Bit sequence |
| 881   | Main Actual Value                | 0                   | No                       | No      | 0                | Signed 16    |
| 904   | PPO selection                    | 10                  | Yes                      | No      | 0                | 6            |
| 915   | PCD write configuration          | 0                   | Yes                      | No      | 0                | 6            |
| 916   | PCD read configuration           | 0                   | Yes                      | No      | 0                | 6            |
| 917   | Active Spontaneous Message       | OFF                 | Yes                      | No      | 0                | Bit sequence |
| 918   | Station Address                  | 63                  | Yes                      | No      | 0                | 6            |
| 953   | Warning Messages                 | 0                   | No                       | No      | 0                | Bit sequence |
| 967   | Control Word                     | 0                   | Yes                      | No      | 0                | Bit sequence |
| 968   | Status Word                      | 0                   | No                       | No      | 0                | Bit sequence |
| 970   | Parameter setup selection        | Active setup        | Yes                      | No      | 0                | 5            |
| 971   | Save data values                 | No action           | Yes                      | No      | 0                | 5            |
| 980   | 1 Defined parameters             | 0                   | No                       | No      | 0                | 6            |
| 981   | 2 Defined parameters             | 0                   | No                       | No      | 0                | 6            |
| 982   | 3 Defined parameters             | 0                   | No                       | No      | 0                | 6            |
| 990   | 1 Modified parameters            | 0                   | No                       | No      | 0                | 6            |
| 991   | 2 Modified parameters            | 0                   | No                       | No      | 0                | 6            |
| 992   | 3 Modified parameters            | 0                   | No                       | No      | 0                | 6            |

\*\* Automatic reset to (0)S Only in stop mode (VLT must be stopped in order to change data value)



**■ Factory settings**

| PNU # | Parameterdescription         | Factory setting             | Changes during operation | 4-setup | Conv. index | Data type |
|-------|------------------------------|-----------------------------|--------------------------|---------|-------------|-----------|
| 001   | Language                     | English                     | Yes                      | No      | 0           | 5         |
| 002   | Local/remote operation       | Remote-controlled           | Yes                      | Yes     | 0           | 5         |
| 003   | Local reference              | 000,000.000                 | Yes                      | Yes     | -3          | 4         |
| 004   | Active Setup                 | Setup 1                     | Yes                      | No      | 0           | 5         |
| 005   | Programming Setup            | Active Setup                | Yes                      | No      | 0           | 5         |
| 006   | Setup copying                | No copying                  | No                       | No      | 0           | 5         |
| 007   | LCP copy                     | No copying                  | No                       | No      | 0           | 5         |
| 008   | Display scaling              | 1.00                        | Yes                      | Yes     | -2          | 6         |
| 009   | Large display readout        | Frequency [Hz]              | Yes                      | Yes     | 0           | 5         |
| 010   | Small display line 1.1       | Reference [%]               | Yes                      | Yes     | 0           | 5         |
| 011   | Small display line 1.2       | Motor current [A]           | Yes                      | Yes     | 0           | 5         |
| 012   | Small display line 1.3       | Power [kW]                  | Yes                      | Yes     | 0           | 5         |
| 013   | Local control                | Remote control as par. 100  | Yes                      | Yes     | 0           | 5         |
| 014   | Local stop/reset             | Active                      | Yes                      | Yes     | 0           | 5         |
| 015   | Local jog                    | Not active                  | Yes                      | Yes     | 0           | 5         |
| 016   | Local reversing              | Not active                  | Yes                      | Yes     | 0           | 5         |
| 017   | Local reset of trip          | Active                      | Yes                      | Yes     | 0           | 5         |
| 018   | Data change lock             | Not locked                  | Yes                      | Yes     | 0           | 5         |
| 019   | Operating status at power up | Forced stop, use saved ref. | Yes                      | Yes     | 0           | 5         |
| 020   | Lock for Hand mode           | Active                      | Yes                      | No      | 0           | 5         |
| 024   | User-defined Quick Menu      | Not active                  | Yes                      | No      | 0           | 5         |
| 025   | Quick Menu Setup             | 000                         | Yes                      | No      | 0           | 6         |
| 026   | LED Status                   | Overload                    | Yes                      | Yes     | 0           | 5         |

**4-Setup:**

'Yes' means that the parameter can be programmed individually in each of the four Setups, i.e. one single parameter can have four different data values. No' means that the data value will be the same in all Setups.

| Data type | Description |
|-----------|-------------|
| 3         | Integer 16  |
| 4         | Integer 32  |
| 5         | Unsigned 8  |
| 6         | Unsigned 16 |
| 7         | Unsigned 32 |
| 9         | Text string |

**Conversion index:**

This number refers to a conversion figure to be used when writing or reading via serial communication with a frequency converter.

| Conversion index | Conversion factor |
|------------------|-------------------|
| 73               | 0.1               |
| 2                | 100               |
| 1                | 10                |
| 0                | 1                 |
| -1               | 0.1               |
| -2               | 0.01              |
| -3               | 0.001             |
| -4               | 0.0001            |
| -5               | 0.00001           |

See also *Serial communication*.

**Data type:**

Data type shows the type and length of the telegram.

**■ Factory settings**

| PNU # | Parameter-description                 | Factory setting           | Changes during operation | 4-setup | Conv. index | Data-type |
|-------|---------------------------------------|---------------------------|--------------------------|---------|-------------|-----------|
| 100   | Configuration                         | Speed reg., open loop     | No                       | Yes     | 0           | 5         |
| 101   | Torque characteristics                | Constant torque           | Yes                      | Yes     | 0           | 5         |
| 102   | Motor power $P_{M,N}$                 | depends on unit           | No                       | Yes     | 1           | 6         |
| 103   | Motor voltage $U_{M,N}$               | depends on unit           | No                       | Yes     | -2          | 6         |
| 104   | Motor frequency $f_{M,N}$             | 50 Hz                     | No                       | Yes     | -1          | 6         |
| 105   | Motor current $I_{M,N}$               | depends on motor selected | No                       | Yes     | -2          | 7         |
| 106   | Rated motor speed                     | depends on par. 102       | No                       | Yes     | 0           | 6         |
| 107   | Automatic motor adjustment            | Optimisation off          | No                       | Yes     | 0           | 5         |
| 108   | Stator resistance $R_s$               | depends on motor selected | No                       | Yes     | -3          | 7         |
| 109   | Stator reactance $X_s$                | depends on motor selected | No                       | Yes     | -2          | 7         |
| 117   | Resonance dampening                   | 0 %                       | Yes                      | Yes     | 0           | 5         |
| 119   | High start torque                     | 0.0 sec                   | No                       | Yes     | -1          | 5         |
| 120   | Start delay                           | 0.0 sec                   | No                       | Yes     | -1          | 5         |
| 121   | Start function                        | Coast in start del.       | No                       | Yes     | 0           | 5         |
| 122   | Function at stop                      | Coast                     | No                       | Yes     | 0           | 5         |
| 123   | Min. freq. for activation of par. 122 | 0.1 Hz                    | No                       | Yes     | -1          | 5         |
| 126   | DC braking time                       | 10 sec.                   | Yes                      | Yes     | -1          | 6         |
| 127   | DC brake engaging frequency           | OFF                       | Yes                      | Yes     | -1          | 6         |
| 128   | Thermal motor protection              | No protection             | Yes                      | Yes     | 0           | 5         |
| 130   | Start frequency                       | 0.0 Hz                    | No                       | Yes     | -1          | 5         |
| 131   | Voltage at start                      | 0.0 V                     | No                       | Yes     | -1          | 6         |
| 132   | DC brake voltage                      | 0%                        | Yes                      | Yes     | 0           | 5         |
| 133   | Start voltage                         | depends on unit           | Yes                      | Yes     | -2          | 6         |
| 134   | Load compensation                     | 100 %                     | Yes                      | Yes     | -1          | 6         |
| 135   | U/f-ratio                             | depends on unit           | Yes                      | Yes     | -2          | 6         |
| 136   | Slip compensation                     | 100 %                     | Yes                      | Yes     | -1          | 3         |
| 137   | DC hold voltage                       | 0%                        | No                       | Yes     | 0           | 5         |
| 138   | Brake cut out value                   | 3.0 Hz                    | Yes                      | Yes     | -1          | 6         |
| 139   | Brake cut in frequency                | 3.0 Hz                    | Yes                      | Yes     | -1          | 6         |
| 140   | Current, minimum value                | 0%                        | No                       | Yes     | 0           | 5         |
| 142   | Leak reactance                        | depends on motor selected | No                       | Yes     | -3          | 7         |
| 144   | AC brake factor                       | 1.30                      | No                       | Yes     | -2          | 5         |
| 146   | Reset voltage vector                  | Off                       | Yes                      | Yes     | 0           | 5         |
| 147   | Motor type                            | General                   |                          |         |             |           |

**■ Factory Settings**

| PNU # | Parameter description                  | Factory setting          | Changes during operation | 4-setup | Conv. index | Data type |
|-------|--|--------------------------|--------------------------|---------|-------------|-----------|
| 200   | Output frequency range                 | Clockwise only, 0-132 Hz | No                       | Yes     | 0           | 5         |
| 201   | Output frequency, low limit $f_{MIN}$  | 0.0 Hz                   | Yes                      | Yes     | -1          | 6         |
| 202   | Output frequency, high limit $f_{MAX}$ | 132 Hz                   | Yes                      | Yes     | -1          | 6         |
| 203   | Reference range                        | Min ref.-Max ref.        | Yes                      | Yes     | 0           | 5         |
| 204   | Minimum ref $Ref_{MIN}$                | 0.000 Hz                 | Yes                      | Yes     | -3          | 4         |
| 205   | Maximum ref $Ref_{MAX}$                | 50.000 Hz                | Yes                      | Yes     | -3          | 4         |
| 206   | Ramp type                              | Linear                   | Yes                      | Yes     | 0           | 5         |
| 207   | Ramp-up time 1                         | 3.00 sec.                | Yes                      | Yes     | -2          | 7         |
| 208   | Ramp-down time 1                       | 3.00 sec.                | Yes                      | Yes     | -2          | 7         |
| 209   | Ramp-up time 2                         | 3.00 sec.                | Yes                      | Yes     | -2          | 7         |
| 210   | Ramp-down time 2                       | 3.00 sec.                | Yes                      | Yes     | -2          | 7         |
| 211   | Jog ramp time                          | 3.00 sec.                | Yes                      | Yes     | -2          | 7         |
| 212   | Quick stop ramp-down time              | 3.00 sec.                | Yes                      | Yes     | -2          | 7         |
| 213   | Jog frequency                          | 10.0 Hz                  | Yes                      | Yes     | -1          | 6         |
| 214   | Reference function                     | Sum                      | Yes                      | Yes     | 0           | 5         |
| 215   | Preset reference 1                     | 0.00%                    | Yes                      | Yes     | -2          | 3         |
| 216   | Preset reference 2                     | 0.00%                    | Yes                      | Yes     | -2          | 3         |
| 217   | Preset reference 3                     | 0.00%                    | Yes                      | Yes     | -2          | 3         |
| 218   | Preset reference 4                     | 0.00%                    | Yes                      | Yes     | -2          | 3         |
| 219   | Catch up/slow down reference           | 0.00%                    | Yes                      | Yes     | -2          | 6         |
| 221   | Current limit                          | 160 %                    | Yes                      | Yes     | -1          | 6         |
| 223   | Warn. Low current                      | 0.0 A                    | Yes                      | Yes     | -1          | 6         |
| 224   | Warn. High current                     | $I_{MAX}$                | Yes                      | Yes     | -1          | 6         |
| 225   | Warn. Low frequency                    | 0.0 Hz                   | Yes                      | Yes     | -1          | 6         |
| 226   | Warn. High frequency                   | 132.0 Hz                 | Yes                      | Yes     | -1          | 6         |
| 227   | Warn. Low Feedback                     | -4000.000                | Yes                      | Yes     | -3          | 4         |
| 228   | Warn. High Feedback                    | 4000.000                 | Yes                      | Yes     | -3          | 4         |
| 229   | Frequency bypass, bandwidth            | 0 Hz (OFF)               | Yes                      | Yes     | 0           | 6         |
| 230   | Frequency bypass 1                     | 0.0 Hz                   | Yes                      | Yes     | -1          | 6         |
| 231   | Frequency bypass 2                     | 0.0 Hz                   | Yes                      | Yes     | -1          | 6         |

## VLT® 2800/FCD 300 DeviceNet

### ■ Factory settings

| PNU # | Parameterdescription             | Factory setting              | Changes during operation | 4-setup | Conv. index | Data type |
|-------|----------------------------------|------------------------------|--------------------------|---------|-------------|-----------|
| 302   | Digital input, term. 18          | Start                        | Yes                      | Yes     | 0           | 5         |
| 303   | Digital input, term. 19          | Reversing                    | Yes                      | Yes     | 0           | 5         |
| 304   | Digital input, term. 27          | Reset and coast inverse      | Yes                      | Yes     | 0           | 5         |
| 305   | Digital input, term. 29          | Jog                          | Yes                      | Yes     | 0           | 5         |
| 307   | Digital input, term. 33          | No function                  | Yes                      | Yes     | 0           | 5         |
| 308   | Term. 53, analogue input voltage | Reference                    | Yes                      | Yes     | 0           | 5         |
| 309   | Term. 53, min scaling            | 0.0 V                        | Yes                      | Yes     | -1          | 6         |
| 310   | Term. 53, max scaling            | 10.0 V                       | Yes                      | Yes     | -1          | 6         |
| 314   | Term. 60, analogue input current | No function                  | Yes                      | Yes     | 0           | 5         |
| 315   | Term. 60, min scaling            | 0.0 mA                       | Yes                      | Yes     | -4          | 6         |
| 316   | Term. 60, max scaling            | 20.0 mA                      | Yes                      | Yes     | -4          | 6         |
| 317   | Time out                         | 10 sec.                      | Yes                      | Yes     | -1          | 5         |
| 318   | Function after timeout           | No function                  | Yes                      | Yes     | 0           | 5         |
| 319   | Term. 42, analogue output        | 0-I <sub>MAX</sub> = 0-20 mA | Yes                      | Yes     | 0           | 5         |
| 323   | Relay output                     | No function                  | Yes                      | Yes     | 0           | 5         |
| 327   | Pulse Max. 33                    | 5000 Hz                      | Yes                      | Yes     | 0           | 7         |
| 328   | Pulse Max. 29                    | 5000 Hz                      | Yes                      | Yes     | 0           | 7         |
| 341   | Term. 46 digital output          | No function                  | Yes                      | Yes     | 0           | 5         |
| 342   | Term. 46 Max. pulse output       | 5000 Hz                      | Yes                      | Yes     | 0           | 6         |
| 343   | Precise stop function            | Normal ramp stop             | No                       | Yes     | 0           | 5         |
| 344   | Counter value                    | 100000 pulses                | No                       | Yes     | 0           | 7         |
| 349   | Speed comp delay                 | 10 ms                        | Yes                      | Yes     | -3          | 6         |

**■ Factory settings**

| PNU # | Parameter description               | Factory setting      | Changes during operation | 4-setup | Conv. index | Data type |
|-------|-------------------------------------|----------------------|--------------------------|---------|-------------|-----------|
| 400   | Brake function                      | Depends on unit type | Yes                      | No      | 0           | 5         |
| 405   | Reset function                      | Manual reset         | Yes                      | Yes     | 0           | 5         |
| 406   | Aut. restart time                   | 5 sec.               | Yes                      | Yes     | 0           | 5         |
| 409   | Trip delay overcurrent              | Off (61 sec.)        | Yes                      | Yes     | 0           | 5         |
| 411   | Switching frequency                 | 4.5 kHz              | Yes                      | Yes     | 0           | 6         |
| 413   | Overmodulation function             | On                   | Yes                      | Yes     | 0           | 5         |
| 414   | Min. feedback                       | 0.000                | Yes                      | Yes     | -3          | 4         |
| 415   | Max. feedback                       | 1500.000             | Yes                      | Yes     | -3          | 4         |
| 416   | Process units                       | No unit              | Yes                      | Yes     | 0           | 5         |
| 417   | Speed PID propor.ampl.              | 0.010                | Yes                      | Yes     | -3          | 6         |
| 418   | Speed PID intergra.                 | 100 ms               | Yes                      | Yes     | -5          | 7         |
| 419   | Speed PID differentiation time      | 20.00 ms             | Yes                      | Yes     | -5          | 7         |
| 420   | Speed PID diff. amplification limit | 5.0                  | Yes                      | Yes     | -1          | 6         |
| 421   | Speed PID lowpass filter            | 20 ms                | Yes                      | Yes     | -3          | 6         |
| 423   | U1 voltage                          | par. 103             | Yes                      | Yes     | -1          | 6         |
| 424   | F1 frequency                        | Par. 104             | Yes                      | Yes     | -1          | 6         |
| 425   | U2 voltage                          | par. 103             | Yes                      | Yes     | -1          | 6         |
| 426   | F2 frequency                        | par. 104             | Yes                      | Yes     | -1          | 6         |
| 427   | U3 voltage                          | par. 103             | Yes                      | Yes     | -1          | 6         |
| 428   | F3 frequency                        | par. 104             | Yes                      | Yes     | -1          | 6         |
| 437   | Proc. PID no/inv.                   | Normal               | Yes                      | Yes     | 0           | 5         |
| 438   | Proc. PID anti wind.                | Active               | Yes                      | Yes     | 0           | 5         |
| 439   | Proc. PID start frequency           | Par. 201             | Yes                      | Yes     | -1          | 6         |
| 440   | Proc. PID start proportional ampl.  | 0.01                 | Yes                      | Yes     | -2          | 6         |
| 441   | Proc. PID integration time          | Off (9999.99 s)      | Yes                      | Yes     | -2          | 7         |
| 442   | Proc. PID differentiation time      | Off (0.00 s).        | Yes                      | Yes     | -2          | 6         |
| 443   | Proc. PID diff. ampl. limit         | 5.0                  | Yes                      | Yes     | -1          | 6         |
| 444   | Proc. PID lowpass filter time       | 0.02 s               | Yes                      | Yes     | -2          | 6         |
| 445   | Flying start                        | Not possible         | Yes                      | Yes     | 0           | 5         |
| 451   | Speed PID feedforward factor        | 100%                 | Yes                      | Yes     | 0           | 6         |
| 452   | Controller range                    | 10 %                 | Yes                      | Yes     | -1          | 6         |
| 455   | Frequency range monitor             | Enable               | Yes                      |         | 0           | 5         |
| 456   | Brake voltage reduce                | 0                    | Yes                      | Yes     | 0           | 5         |

**■ Factory settings**

| PNU # | Parameterdescription                   | Factory setting | Changes during operation | 4-setup | Conv. index | Data type |
|-------|--|-----------------|--------------------------|---------|-------------|-----------|
| 500   | Address                                | 1               | Yes                      | No      | 0           | 5         |
| 501   | Baudrate                               | 9600 Baud       | Yes                      | No      | 0           | 5         |
| 502   | Coasting stop                          | Logic or        | Yes                      | Yes     | 0           | 5         |
| 503   | Quick stop                             | Logic or        | Yes                      | Yes     | 0           | 5         |
| 504   | DC brake                               | Logic or        | Yes                      | Yes     | 0           | 5         |
| 505   | Start                                  | Logic or        | Yes                      | Yes     | 0           | 5         |
| 506   | Reversing                              | Logic or        | Yes                      | Yes     | 0           | 5         |
| 507   | Selection of Setup                     | Logic or        | Yes                      | Yes     | 0           | 5         |
| 508   | Selection of preset ref.               | Logic or        | Yes                      | Yes     | 0           | 5         |
| 509   | Bus jog 1                              | 10.0 Hz         | Yes                      | Yes     | -1          | 6         |
| 510   | Bus jog 2                              | 10.0 Hz         | Yes                      | Yes     | -1          | 6         |
| 512   | Telegram profile                       | FC protocol     | No                       | Yes     | 0           | 5         |
| 513   | Bus time interval                      | 1 sec.          | Yes                      | Yes     | 0           | 5         |
| 514   | Bus time interval function             | Off             | Yes                      | Yes     | 0           | 5         |
| 515   | Data readout: Reference %              |                 | No                       | No      | -1          | 3         |
| 516   | Data readout: Reference [unit]         |                 | No                       | No      | -3          | 4         |
| 517   | Data readout: Feedback [unit]          |                 | No                       | No      | -3          | 4         |
| 518   | Data readout: Frequency                |                 | No                       | No      | -1          | 3         |
| 519   | Data readout: Frequency x scaling      |                 | No                       | No      | -1          | 3         |
| 520   | Data readout: Motor current            |                 | No                       | No      | -2          | 7         |
| 521   | Data readout: Torque                   |                 | No                       | No      | -1          | 3         |
| 522   | Data readout: Power [kW]               |                 | No                       | No      | 1           | 7         |
| 523   | Data readout: Power [HP]               |                 | No                       | No      | -2          | 7         |
| 524   | Data readout: Motor voltage [V]        |                 | No                       | No      | -1          | 6         |
| 525   | Data readout: DC Link voltage          |                 | No                       | No      | 0           | 6         |
| 526   | Data readout: Motor thermal load       |                 | No                       | No      | 0           | 5         |
| 527   | Data readout: Inverter thermal load    |                 | No                       | No      | 0           | 5         |
| 528   | Data readout: Digital input            |                 | No                       | No      | 0           | 5         |
| 529   | Data readout: Analogue input, term. 53 |                 | No                       | No      | -1          | 5         |
| 531   | Data readout: Analogue input, term. 60 |                 | No                       | No      | -4          | 5         |
| 532   | Data readout: Pulse input, term. 33    |                 | No                       | No      | -1          | 7         |
| 533   | Data readout: External reference       |                 | No                       | No      | -1          | 6         |
| 534   | Data readout: Status word              |                 | No                       | No      | 0           | 6         |
| 537   | Data readout: Inverter temperature     |                 | No                       | No      | 0           | 5         |
| 538   | Data readout: Alarm word               |                 | No                       | No      | 0           | 7         |
| 539   | Data readout: Control word             |                 | No                       | No      | 0           | 6         |
| 540   | Data readout: Warning word             |                 | No                       | No      | 0           | 7         |
| 541   | Data readout: Extended status word     |                 | No                       | No      | 0           | 7         |
| 544   | Data readout: Pulse count              |                 | No                       | No      | 0           | 7         |
| 545   | Data readout: Pulse input, term. 29    |                 | No                       | No      | -1          | 7         |

**■ Factory settings**

| PNU # | Parameterdescription                             | Factory setting      | Changes during operation | 4-setup | Conv. index | Data type |
|-------|--|----------------------|--------------------------|---------|-------------|-----------|
| 600   | Operating hours                                  |                      | No                       | No      | 73          | 7         |
| 601   | Hours run  |                      | No                       | No      | 73          | 7         |
| 602   | kWh counter                                      |                      | No                       | No      | 2           | 7         |
| 603   | Number of cut ins                                |                      | No                       | No      | 0           | 6         |
| 604   | Number of overtemperatures                       |                      | No                       | No      | 0           | 6         |
| 605   | Number of overvoltages                           |                      | No                       | No      | 0           | 6         |
| 615   | Fault log: Error code                            |                      | No                       | No      | 0           | 5         |
| 616   | Fault log: Time                                  |                      | No                       | No      | 0           | 7         |
| 617   | Fault log: Value                                 |                      | No                       | No      | 0           | 3         |
| 618   | Reset of kWh counter                             | No reset             | Yes                      | No      | 0           | 7         |
| 619   | Reset of running hours counter                   | No reset             | Yes                      | No      | 0           | 5         |
| 620   | Operation mode                                   | Normal operation     | Yes                      | No      | 0           | 5         |
| 621   | Nameplate: Unit type                             |                      | No                       | No      | 0           | 9         |
| 624   | Nameplate: Software version                      |                      | No                       | No      | 0           | 9         |
| 625   | Nameplate: LCP identification no.                |                      | No                       | No      | 0           | 9         |
| 626   | Nameplate: Database identification no.           |                      | No                       | No      | -2          | 9         |
| 627   | Nameplate: Power parts version                   |                      | No                       | No      | 0           | 9         |
| 628   | Nameplate: Application option type               |                      | No                       | No      | 0           | 9         |
| 630   | Nameplate: Communication option type             |                      | No                       | No      | 0           | 9         |
| 632   | Nameplate: BMC software identification           |                      | No                       | No      | 0           | 9         |
| 634   | Nameplate: Unit identification for communication |                      | No                       | No      | 0           | 9         |
| 635   | Nameplate: Software parts no.                    |                      | No                       | No      | 0           | 9         |
| 640   | Software version                                 |                      | No                       | No      | -2          | 6         |
| 641   | BMC software identification                      |                      | No                       | No      | -2          | 6         |
| 642   | Power card identification                        |                      | No                       | No      | -2          | 6         |
| 678   | Configure Control Card                           | Depends on unit type | No                       | No      | 0           | 5         |

### ■ Additional control features for VLT 2800

#### VLT 2800 Additional control features

Three new means of controlling are available with the DeviceNet version of the VLT 2800:

Reference and feedback as pulse inputs, A/B pulse encoder signals and  $\pm 10$  Volt analogue input (53).

Terminals 29 and 33 can be configured as either pulse reference or pulse feedback. The maximum pulse fre-

quencies are set in par. 327 and 328 respectively. A 24 V encoder with dual track (A-B) pulse train with direction recognition (quadrature signals) can be connected to terminals 29 and 33. Track A must be connected to terminal 29 and track B to 33.

The encoder can be used for either reference, feedback, or as input for the counter function.

| Digital inputs    | Term. no.<br>par. no. | 29<br>305         | 33<br>307         |
|-------------------|-----------------------|-------------------|-------------------|
| Value:            |                       |                   |                   |
| Pulse reference   | (PULSE REFERENCE)     | [28]              | [28]              |
| Pulse feedback    | (PULSE FEEDBACK)      | [29]              | [29]              |
| Pulse input       | (PULSE INPUT)         | [30]              | [30]              |
| Encoder reference | (ENCODER REFERENCE)   | [40] <sup>1</sup> | [40] <sup>1</sup> |
| Encoder feedback  | (ENCODER FEEDBACK)    | [41] <sup>1</sup> | [41] <sup>1</sup> |
| Encoder input     | (ENCODER INPUT)       | [42] <sup>1</sup> | [42] <sup>1</sup> |

1. Settings must be identical for terminal 29 and 33. Encoder reference is selected if the reference signal applied is an A-B encoder signal. 0 Hz corresponds to the setting in par. 204 minimum reference. For running in both directions par. 203 should be set to -max - +max [1], par. 200 to both directions [1], and par. 204 minimum reference to 0.00. The frequency set in par. 327/328 pulse max. 33/29 (will be equaled automatically) corresponds to the value in par. 205 maximum reference.

Encoder feedback is selected if the feedback signal applied is an A-B encoder signal. The frequency set in par. 327/328 pulse max. 33/29 (will be equaled automatically) corresponds to the value in par. 205 maximum feedback.

Encoder input is selected if the encoder signals are to be used for the counter function with precise stop selectable in par. 343 precise stop. The number of pulse before ramp down is specified in par. 344 counter value.



### Example, 0 - ± 10 Volt:

External reference signal = 0 V (min) ± 10 V (max)  
 Reference = 50 Hz ccw - 50 Hz cw  
 Configuration (parameter 100) = Speed control, open loop

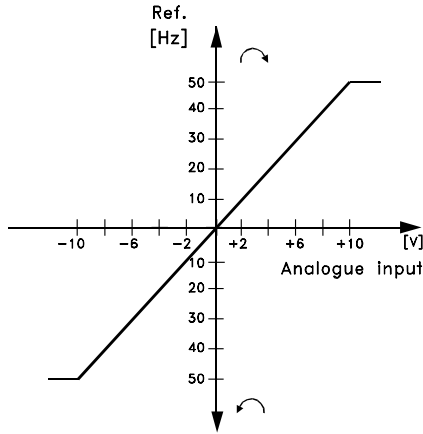

| Setting:   |                                  |                           |                   |
|------------|----------------------------------|---------------------------|-------------------|
| Parameter: |                                  | Setting:                  | Data value:       |
| 100        | Configuration                    | Speed control, open loop  | [0]               |
| 308        | Funct. of analogue input         | Reference                 | [1]               |
| 309        | Min. reference signal            | Min.                      | 0 V               |
| 310        | Max. reference signal            | Max.                      | 10 V              |
| 203        | Reference range                  | Reference range           | - Max - + Max [1] |
| 205        | Max. reference                   |                           | 50 Hz             |
| 200        | Output frequency range/direction | Both directions, 0-132 Hz | [1]               |



---

VLT® 2800/FCD 300 DeviceNet

---