



VLT[®] Active Filter AAF00x Instruction Manual

Contents

1 How to Read the Instruction Manual	1-1
1.1.1 Copyright, Limitation of Liability and Revision Rights	1-1
2 Safety	2-1
2.1.2 General Warning	2-1
2.1.3 Before Commencing Repair Work	2-1
2.1.4 Special Conditions	2-2
2.1.5 Avoid Unintended Start	2-2
2.1.6 IT Line Power	2-2
3 Introduction to VLT Active Filter AAF00x	3-1
3.1.1 Working Principle	3-1
3.1.2 Filter Configurator	3-2
3.1.3 Ordering Form type code	3-3
4 How to Install	4-1
4.1 How to Get Started	4-1
4.2 Pre-installation	4-1
4.2.1 Planning the Installation Site	4-1
4.2.2 Receiving the Active Filter	4-2
4.2.3 Transportation and Unpacking	4-2
4.2.4 Lifting	4-3
4.2.5 Mechanical Dimensions	4-4
4.3 Mechanical Installation	4-9
4.3.3 Terminal Locations - Frame size D	4-10
4.3.4 Terminal Locations - Frame size E	4-11
4.3.5 Cooling and Airflow	4-11
4.4 Field Installation of Options	4-14
4.4.1 Installation of Input Plate Options	4-14
4.5 Electrical Installation	4-15
4.5.1 Power Connections	4-15
4.5.7 Current Transformer (CT)	4-22
4.5.8 Auto CT Detection	4-25
4.5.9 Summation Transformers	4-26
4.5.10 Active Filter Operating with Capacitor Banks	4-27
4.5.11 Fuses	4-28
4.5.13 Control and CT Cable Routing	4-29
4.5.15 Unshielded Control Wires	4-30

4.6.1 Electrical Installation, Control Cables	4-32
4.7 Paralleling of Active Filter Units	4-34
4.8 Final Set-Up and Test	4-36
5 How to Operate the Active Filter	5-1
5.1.1 How to Operate Graphical LCP (GLCP)	5-1
5.1.6 Tips and Tricks	5-4
6 How to Program	6-1
6.2.1 Main Menu	6-4
6.3 0-** Operation/Display	6-4
6.4 5-** Digital I/O Mode	6-11
6.5 8-** General Settings	6-14
6.6 14-2* Trip Reset	6-17
6.7 15-0* Operating Data	6-19
6.8 16-0* General Status	6-23
6.9 300-**	6-25
6.10 301-**	6-27
6.11 Parameter Lists	6-28
6.11.1 Default settings	6-28
6.11.2 Operation/Display 0-**	6-29
6.11.3 Digital In/Out 5-**	6-30
6.11.4 Comm. and Options 8-**	6-30
6.11.5 Special Functions 14-**	6-31
6.11.6 Adj. Freq. Drive Information 15-**	6-32
6.11.7 Data Readouts 16-**	6-33
6.11.8 AF Settings 300-**	6-34
6.11.9 AF Readouts 301-**	6-35
7 RS-485 Installation and set-up	7-1
7.2 Network Configuration	7-2
7.3 FC Protocol Message Framing Structure	7-2
7.3.1 Content of a Character (byte)	7-2
7.3.3 Message Length (LGE)	7-3
7.3.5 Data Control Byte (BCC)	7-3
7.3.6 The Data Field	7-3
7.3.8 Parameter Number (PNU)	7-5
7.3.9 Index (IND)	7-5
7.3.10 Parameter Value (PWE)	7-5

7.3.11 Data Types Supported by VLT AutomationDrive	7-5
7.3.12 Conversion	7-6
7.3.13 Process Words (PCD)	7-7
7.4 How to Access Parameters	7-7
7.4.1 Parameter Handling	7-7
7.4.3 IND	7-7
7.4.4 Text Blocks	7-7
7.4.5 Conversion Factor	7-7
7.4.6 Parameter Values	7-7
8 General Specifications	8-1
8.1 Electrical Data	8-1
8.1.1 Power Rating	8-1
9 Troubleshooting	9-1

1 How to Read the Instruction Manual

1.1.1 Copyright, Limitation of Liability and Revision Rights

This publication contains information proprietary to Danfoss. By accepting and using this manual, the user agrees that the information contained herein will be used solely for operating equipment from Danfoss or equipment from other vendors provided that such equipment is intended for communication with Danfoss equipment over a serial communication link. This publication is protected under the copyright laws of Denmark and most other countries.

Danfoss does not warrant that a software program produced according to the guidelines provided in this manual will function properly in every physical, hardware or software environment.

Although Danfoss has tested and reviewed the documentation within this manual, Danfoss makes no warranty or representation, either expressed or implied, with respect to this documentation, including its quality, performance or fitness for a particular purpose.

In no event shall Danfoss be liable for direct, indirect, special, incidental or consequential damages arising from the use, or the inability to use information contained in this manual, even if advised of the possibility of such damages. In particular, Danfoss is not responsible for any costs, including but not limited to those incurred as a result of lost profits or revenue, loss or damage of equipment, loss of computer programs, loss of data, the costs to substitute these, or any claims by third parties.

Danfoss reserves the right to revise this publication at any time and to make changes to its contents without prior notice or any obligation to notify former or present users of such revisions or changes.

Symbols

The following symbols are used in this manual.



Indicates a potentially hazardous situation which, if not avoided, could result in death or serious injury.



Indicates a potentially hazardous situation which, if not avoided, may result in minor or moderate injury. It may also be used to alert against unsafe practices.

CAUTION

Indicates a situation that may result in equipment or property damage-only accidents.

NOTE!

Indicates highlighted information that should be observed in order to avoid mistakes or operate equipment at less than optimal performance.

Approvals

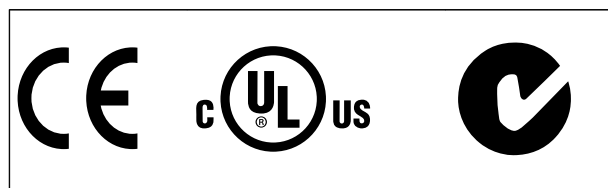

2 Safety

2.1.1 Safety Note

⚠ WARNING

The voltage of the active filter is dangerous whenever connected to line power. Incorrect installation of the filter or options may cause damage to the equipment, serious personal injury or death. Consequently, the instructions in this manual, as well as national and local rules and safety regulations, must be complied with.

Safety regulations

1. The filter must be disconnected from line power if repair work is to be carried out. Check that the line power supply has been disconnected and that the necessary time has passed before removing line power plugs.
2. The [OFF] key on the control panel does not disconnect the equipment from line power and is thus not to be used as a safety switch.
3. Correct protective grounding of the equipment must be established and the user must be protected against supply voltage in accordance with applicable national and local regulations.
4. The ground leakage currents are higher than 3.5mA.
5. Do not remove the plugs for the line power while the filter is connected to line power supply. Check that the line power supply has been disconnected and that the necessary time has passed before removing line power plugs.
6. Please note that the filter has voltage inputs other than L1, L2 and L3, when external 24V DC have been installed. Make sure that all voltage inputs have been disconnected and that the necessary time has passed before commencing repair work.

Installation at high altitudes

NOTE!

At altitudes above 9843 ft [3 km], please contact Danfoss Drives regarding PELV.

2.1.2 General Warning

⚠ WARNING

Touching the electrical parts may be fatal - even after the equipment has been disconnected from line power.

Before touching any potentially live parts of the unit, wait at least as follows:

380–480 V, 190–400A, wait at least 20 minutes.

Shorter time is allowed only if indicated on the nameplate for the specific unit. Be aware that there may be high voltage on the DC links even when the control card LEDs are turned off. A red LED is mounted on a circuit board inside the active filter to indicate the DC bus voltages. The red LED will stay lit until the DC link is 50V DC or lower.

⚠ CAUTION

Leakage current

The ground leakage current from the filter exceeds 3.5mA. According to IEC 61800-5-1 a reinforced protective ground connection must be ensured by means of an PE wire - with the same cable cross-section as the line power wiring - must be terminated separately.

Residual Current Device

This product can cause DC current in the protective conductor. Where a residual current device (RCD) is used for extra protection, only an RCD of Type B (time delayed) shall be used on the supply side of this product. Protective grounding of the filter and the use of RCDs must always follow national and local regulations.

2.1.3 Before Commencing Repair Work

⚠ WARNING

Hazardous Voltage!

1. Disconnect the filter from line power
2. Wait at least the amount of time indicated in section General Warning above

Failure to follow recommendations could result in death or serious injury.

2.1.4 Special Conditions

Electrical ratings:

The rating indicated on the nameplate of the active filter is based on a typical 3-phase line power supply, within the specified voltage, current and temperature range, which is expected to be used in most applications.

The unit also supports other special applications, which affect the electrical ratings of the filter. Special conditions that affect the electrical ratings might be:

- High temperature applications which require derating of the electrical ratings
- High altitude installation which require derating of the electrical ratings
- Marine applications with more severe environmental conditions

Consult the relevant clauses in these instructions for information about the electrical ratings.

Installation requirements:

The overall electrical safety of the active filter requires special installation considerations regarding:

- Fuses and circuit breakers for overcurrent and short-circuit protection
- Selection of power cables (line power and relays)
- Grid configuration (IT,TN, grounded leg, etc.)
- Safety of low-voltage terminals (PELV conditions)

Consult the relevant clauses in these instructions for information about the installation requirements.

2.1.5 Avoid Unintended Start

NOTE!

While the active filter is connected to line power, the device can be started/stopped using digital commands, bus commands, references or via the Local Control Panel.

- **Disconnect the unit from line power whenever personal safety considerations make it necessary to avoid unintended start.**
- **To avoid unintended start, always activate the [OFF] key before changing parameters.**

2.1.6 IT Line Power

NOTE!

IT line power

Do not connect the unit with RFI filters to line power supplies with a voltage between phase and ground of more than 440V for 400V.

For 400V IT line power and delta ground (grounded leg), AC line voltage may exceed 440V between phase and ground.

14-50 RFI Filter can be used to disconnect the internal RFI capacitors from the RFI filter to ground.

2.1.7 Disposal Instructions

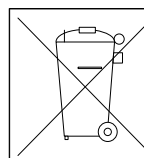

Equipment containing electrical components may not be disposed of together with domestic waste.

It must be separately collected with electrical and electronic waste according to local and currently valid legislation.

3 Introduction to VLT Active Filter AAF00x

3.1.1 Working Principle

VLT® Active Filter AAF00x is a device for harmonic current mitigation and reactive current compensation. The unit is designed for installation in various systems and applications as centrally installed filter(s) or combined with a VLT Adjustable frequency drive as a packaged low harmonic drive solution.

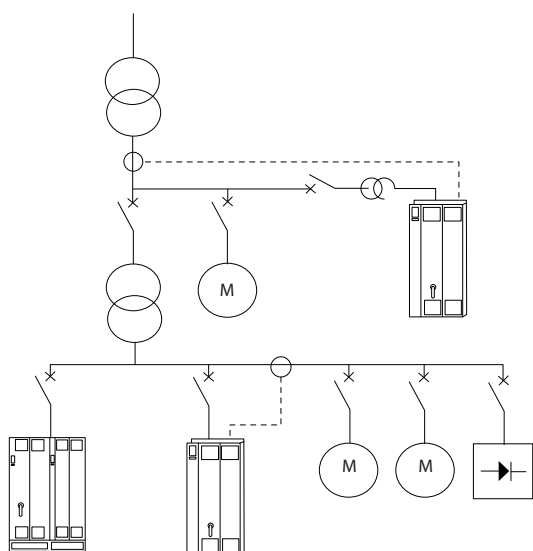

130BB717.10

The active shunt filter monitors all three phase line currents and processes the measured current signal via a digital signal processor system. The filter then compensates by actively imposing signals in counter phase to the unwanted elements of the current.

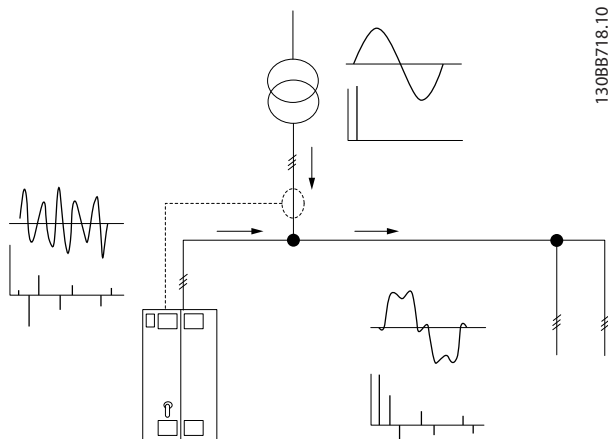

130BB718.10

The counter phase signals are generated by setting different IGBT switches in real time feeding a DC voltage into the grid. The compensated current waveform is smoothed via a built-in LCL filter making sure that the IGBT switching frequency and DC component is not imposed to the grid. The filter is able to operate on generator or transformer supply and is able to reduce individual motor, non-linear loads or mixed loads. All nonlinear-loads (diode feed loads) must hold AC coils to protect these units against overcurrent of the input diodes.

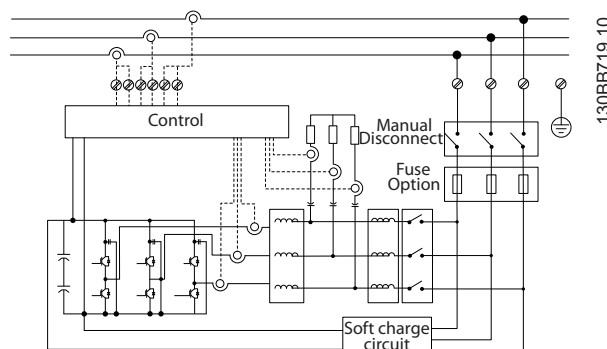

130BB719.10

The factory settings allow for fast start-up, though dedicated programming is possible through the local user control panel LCP allowing adaptation to more demanding applications.

The filter allows either overall or selective harmonic compensation modes. In overall compensation mode all harmonics will be reduced towards zero. In this operation mode the filter will also balance out the load to reduce uneven load distribution between the three phases. The steady state performance will allow the compensation of harmonics until the 40th order, though the ultra-quick current injection allows the filter to also compensate flicker and other quick and short-term phenomenon. In selective mode, the filter allows the user to program acceptable individual harmonic levels between the 5th and 25th orders. In selective mode the filter will not reduce even harmonic orders or triplings, nor will it support phase load balancing and flicker reduction.

In addition to the harmonic compensation mode the filter also allows the user to program the filter priority from either reactive current or harmonic compensation. If harmonic compensation is chosen as the first priority, the filter will use the necessary current for harmonic reduction and energy for reactive current correction, though only if

excess energy is at hand. The filter will automatically and continuously assign energy between first and second priorities to provide the highest possible mitigation of both reactive and harmonic compensation. This ensures that the true power factor is continuously optimized and that the highest possible utilization of the supply transformer current is secured. Filter LCP provides a user-friendly programming structure and allows multiple readouts on the LCP. Some readouts are calculated and approximated values and, consequently, they cannot be compared with readouts of a power quality analyzer due to different sample rates and harmonic order content.

It is not possible to overload the active filter due to the self protection circuitry that automatically reduces the compensated current to a level where the filter is at a stable temperature condition. If the mitigation demand is higher than the filter rating, the filter will compensate to the best of its ability and leave remaining harmonics or reactive currents unaffected.

The active filter is standard equipped with an RFI filter fulfilling the EMC industrial (second) environment standard IEC55011 Class A2 equal category C3 of IEC61800-3.

3.1.2 Filter Configurator

It is possible to design an active filter according to the application requirements by using the ordering number system. For the VLT Active Filter AAF 00x Series, you can order standard filters and filters with integral options by sending a type code string describing the product to the local Danfoss sales office, i.e.:

AAF 00XA190T4E21H2xGCXXSXXXXAxBXCFXXDX

The meaning of the characters in the string can be located in the following pages containing the ordering numbers and option settings. In the example above a standard 190A Active Filter is chosen in an IP21 enclosure for a 380–480V net. From the Internet based configurator, you can configure the right filter for the right application and generate the type code string. The configurator will automatically generate an 8-digit sales number to be delivered to your local sales office. Furthermore, you can establish a project list with several products and send it to a Danfoss sales representative. The configurator can be found on the global Internet site: www.danfoss.com/drives.

Filters will automatically be delivered with a language package relevant to the region from which it is ordered. Four regional language packages cover the following languages:

Language package 1

English, German, French, Danish, Dutch, Spanish, Swedish, Italian and Finnish.

Language package 2

English, German, Chinese, Korean, Japanese, Thai, Traditional Chinese and Bahasa Indonesian.

Language package 3

English, German, Slovenian, Bulgarian, Serbian, Romanian, Hungarian, Czech and Russian.

Language package 4

English, German, Spanish, English US, Greek, Brazilian Portuguese, Turkish and Polish.

To order filters with a different language package, please contact your local sales office.

3.1.3 Ordering Form type code

1	2	3	4	5	6	7	8	9	10	11	12	13	14	15	16	17	18	19	20	21	22	23	24	25	26	27	28	29	30	31	32	33	34	35	36	37	38	39
A	A	F	0	0	x	A				T	4	E			H		x	G	C		x	x	S	x	x	x	x	A	x	B	x	C	x	x	x	x	D	x

130BBS04.10



		Possible choice
Product groups	1-3	AAF
Series	4-6	005
Current rating	7-10	A190: 190Amp A250: 250Amp
Phases	11	T: Three Phases
AC Line Voltage	12	4: 380–480V AC
enclosure	13-15	E21: IP21/Nema Type1 ESH: IP54 hybrid
RFI filter	16-17	H2: RFI filter, Class A2 (standard) H4: RFI filter, Class A1 (optional)
Display (LCP)	19	G: Graphical Local Control Panel (LCP)
Coating PCB	20	C: Coated PCB
Line power option	21	X: No AC line option 3: Line power disconnect and fuse 7: Fuse
Adaptation A	22	Reserved
Adaptation B	23	Reserved
Software release	24-27	Reserved
Software language	28	Reserved
A options	29-30	AX: No A option
B options	31-32	BX: No B option
C option configuration	33-37	CFxxx: CO option occupied with active filter control card
D options	38-39	DX: No Options

		Possible choice
Product groups	1-3	AAF
Series	4-6	006
Current rating	7-10	A190: 190Amp A250: 250Amp A310: 310Amp A400: 400 Amp
Phases	11	T: Three Phases
AC Line Voltage	12	4: 380–480V AC
enclosure	13-15	E21: IP21/Nema Type1 E54: IP54/Nema Type 12 E2M: IP21/Nema Type 1 with line power shield E5M: IP54/Nema Type 12 with line power shield
RFI filter	16-17	H2: RFI filter, Class A2 (standard) H4: RFI filter, Class A1 (optional)
Display (LCP)	19	G: Graphical Local Control Panel (LCP)
Coating PCB	20	C: Coated PCB
Line power option	21	X: No AC line option 3: Line power disconnect and fuse 7: Fuse
Adaptation A	22	Reserved
Adaptation B	23	Reserved
Software release	24-27	Reserved
Software language	28	Reserved
A options	29-30	AQ: MCA-122 Modbus TCP AX: No A option
B options	31-32	BX: No B option
C option configuration	33-37	CFxxx: CO option occupied with active filter control card
D options	38-39	DO: 24V backup DX: No Options

4 How to Install

4.1 How to Get Started

This chapter covers mechanical and electrical installations to and from power terminals and control card terminals.

4.1.1 How to Get Started

The active filter is designed to achieve a quick and EMC-correct installation by following the steps described below.

⚠ WARNING

Read the safety instructions before installing the unit. Failure to follow recommendations could result in death or serious injury.

Mechanical Installation

- Mechanical mounting

Electrical Installation

- Connection to Line and Protecting Ground
- CT connection and cables
- Fuses and circuit breakers
- Control terminals - cables

Quick set-up

- Local Control Panel of filter
- Programming

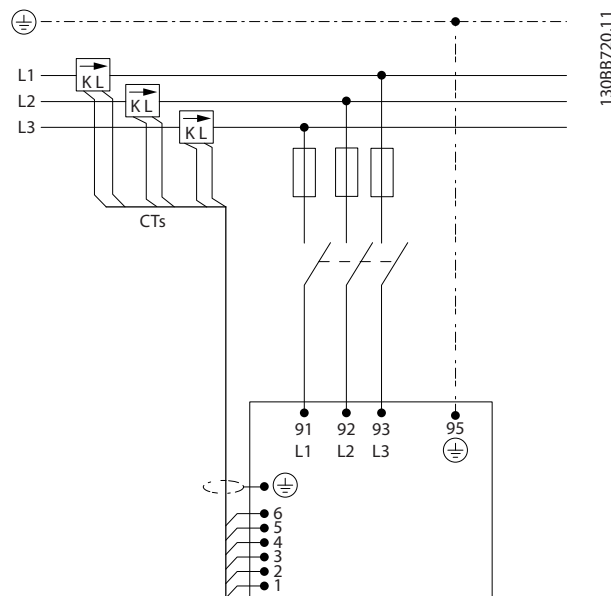

Figure 4.1 Diagram showing basic installation, including line power and CTs.

4.2 Pre-installation

4.2.1 Planning the Installation Site

NOTE!

Before performing the installation, it is important to plan the installation of the filter. Neglecting this may result in extra work during and after installation.

Select the best possible operation site by considering the following (see details on the following pages):

- Ambient temperature conditions
- Altitude at installation point
- Installation and compensation method
- How to cool the unit
- Position of the Active Filter
- CT installation point and possibility to reuse existing CTs
- Cable routing and EMI conditions
- Ensure the power source supplies the correct voltage and frequency
- If the unit is without built-in fuses, ensure that the external fuses are rated correctly.

4.2.2 Receiving the Active Filter

When receiving the unit, please make sure that the packaging is intact, and be aware of any damage that might have occurred to the unit during transport. If damage has occurred, immediately contact the shipping company to make a damage claim.

4

NOTE!

Damaged packaging can indicate inappropriate transport which might have resulted in internal unit damage. Even though the unit seems to be intact externally, make sure to survey the damage.

4.2.3 Transportation and Unpacking

Before unpacking the active filter it is recommended that it is located as close as possible to the final installation site. Keep the filter on the pallet and boxed, as long as possible to avoid scratches and dents.

4.2.4 Lifting

Always lift the unit in the dedicated lifting eyes. Use a bar to avoid bending the lifting holes.

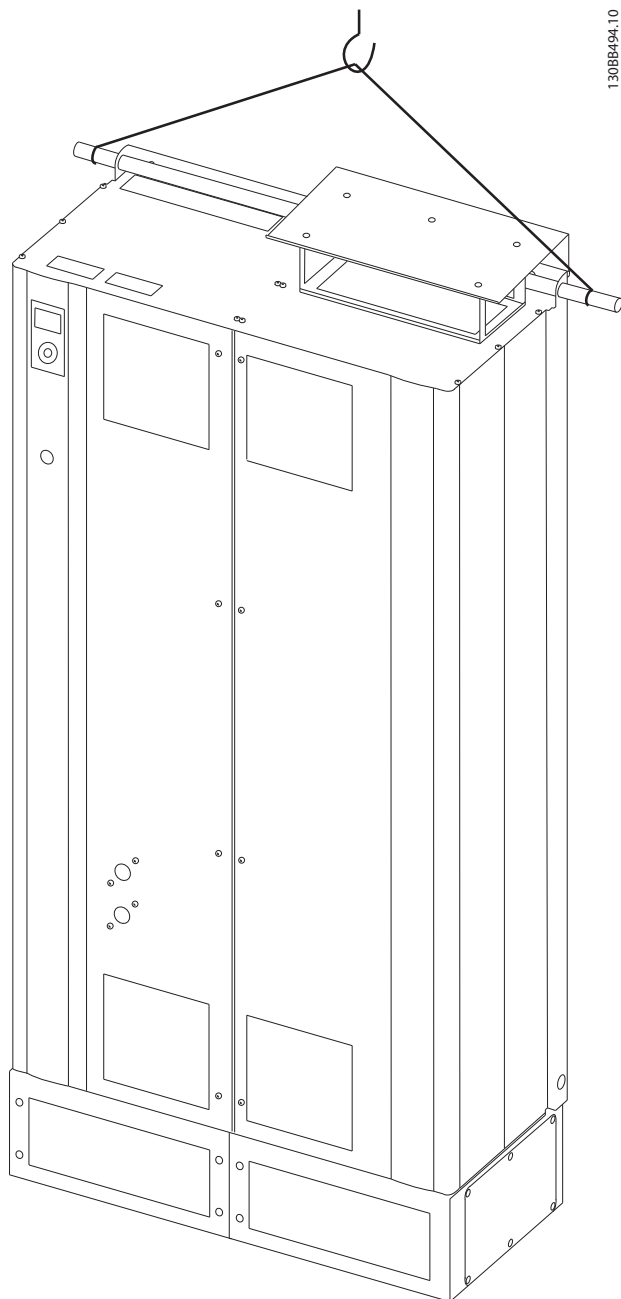

Figure 4.2 Recommended Lifting Method for AAF 005, Frame Sizes D9 and E7.

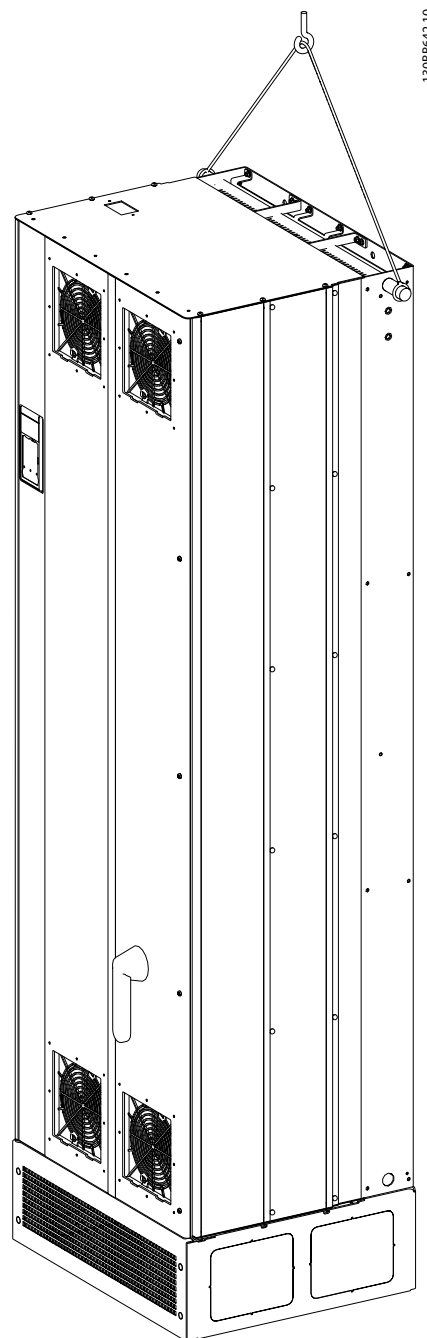

Figure 4.3 Recommended Lifting Method for AAF 006, Frame Sizes D13 and E9.

NOTE!

The lifting bar must be able to handle the weight of the unit. See *Mechanical Dimensions* for the weight of the different frame sizes. Maximum diameter for bar is 1 in [25mm]. The angle from the top of the unit to the lifting cable should be 60° or greater.

NOTE!

Note the plinth is provided in the same packaging as the filter, but is not always attached to frame during shipment. The plinth is required to allow airflow to the unit to provide proper cooling. The plinth of the D and E-frames filters should be mounted before the unit is lifted to its final position.

4.2.5 Mechanical Dimensions

4

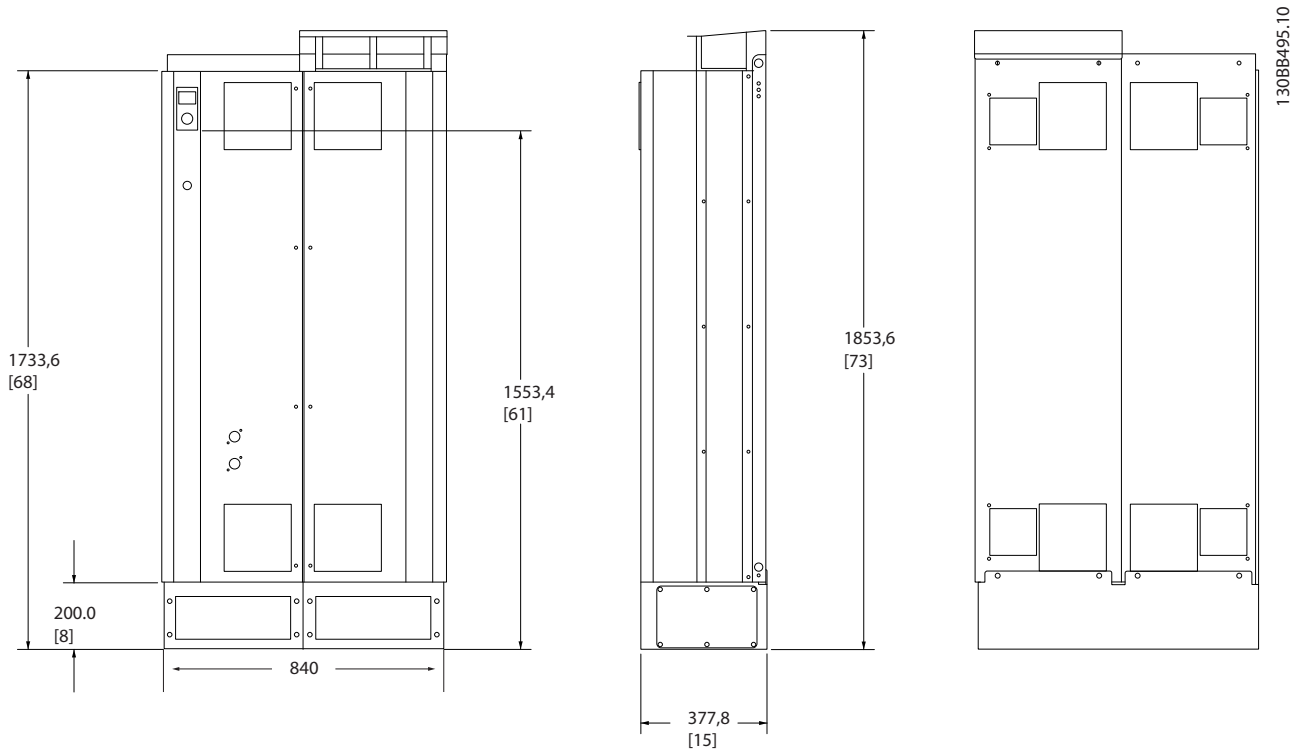

Figure 4.4 Frame size D9, AAF05

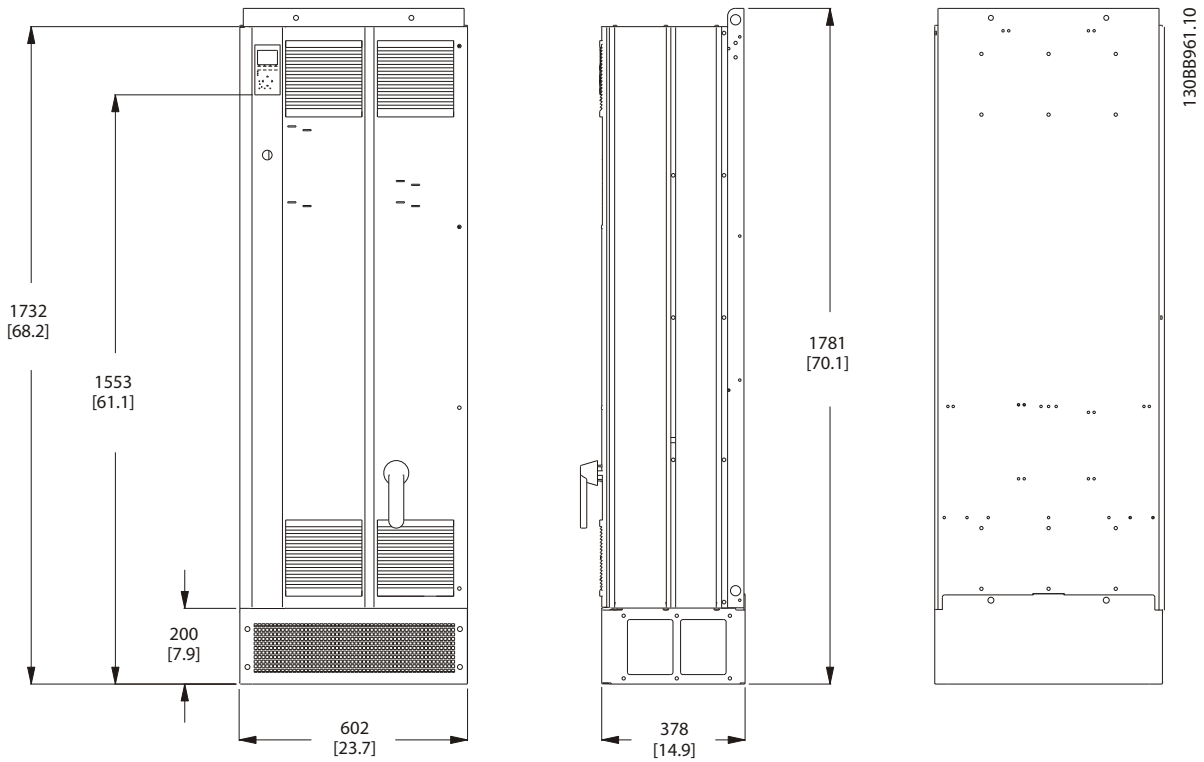

Figure 4.5 Frame size D13, AAF06

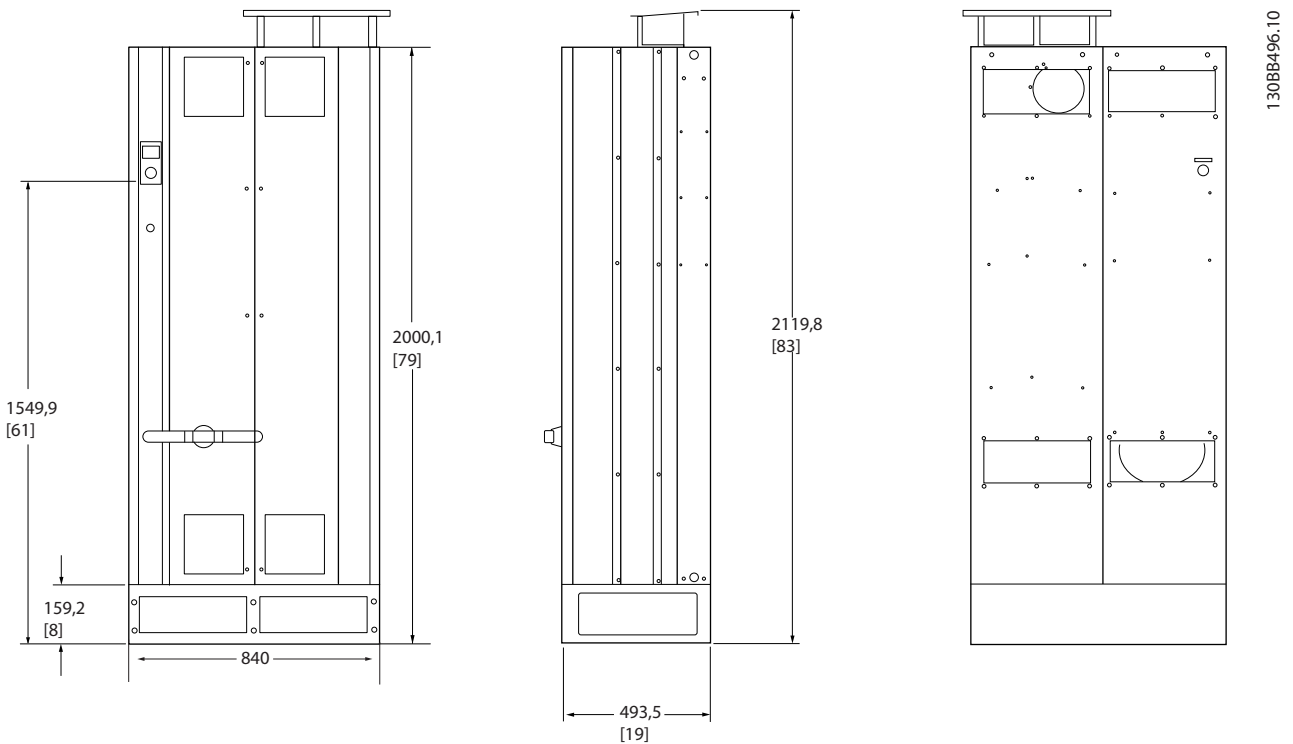
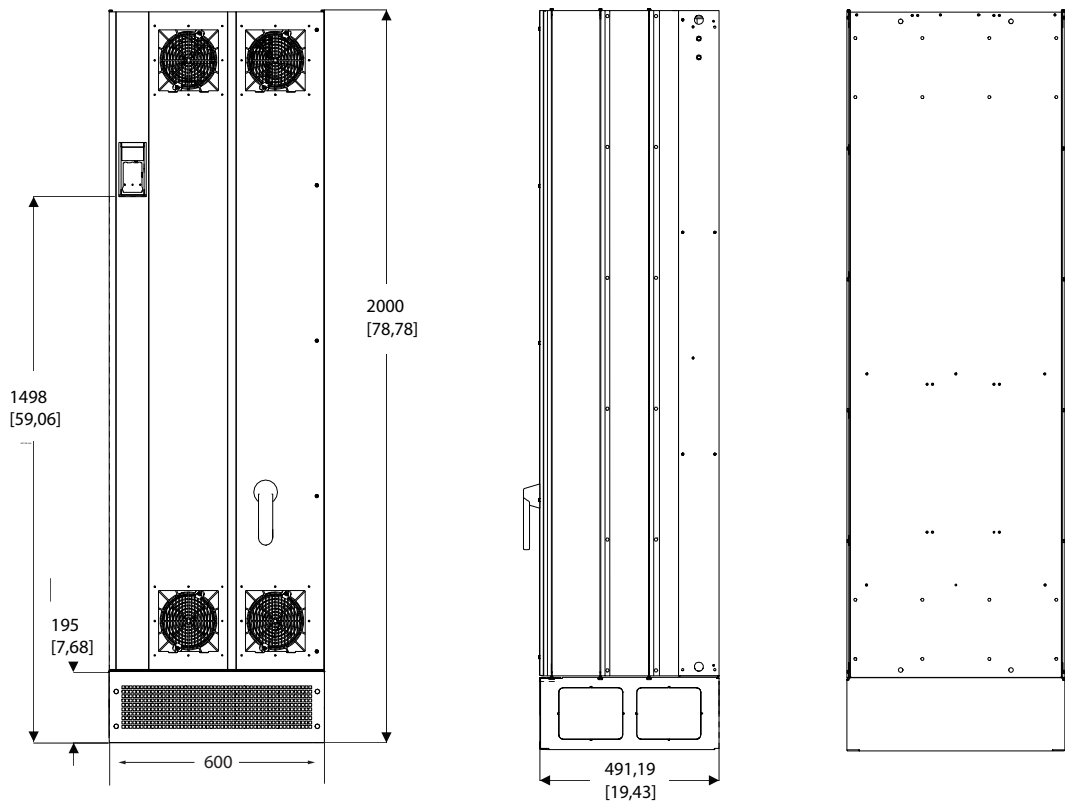



Figure 4.6 Frame size E7, AAF05

4



1308B644.10

Figure 4.7 Frame size E9, AAF06

Mechanical dimensions and rated power			
Frame size		D9	E7
			
Version		AAF05	AAF05
enclosure protection	IP	21/54 hybrid	21/54 hybrid
	NEMA	Type 1	Type 1
Nominal current rate		190A	250A
Shipping Dimensions	Height (in [mm])	72.9 [1852]	83.1 [2111]
	Width (in [mm])	44 [1118]	44 [1118]
	Depth (in [mm])	37.3 [947]	37.3 [947]
	Weight (lbs [kg]):	15.8 [400]	17.7 [450]
Filter Dimensions	Height (in [mm])	68.2 [1732]	78.7 [2000]
	Width (in [mm])	33 [840]	33 [840]
	Depth (in [mm])	15 [380]	19.4 [494]
	Max weight (lbs [kg])	646 [293]	776 [352]

Frame size		Mechanical dimensions and rated power	
		D13	E9
Version		AAF06	AAF06
enclosure protection	IP	21/54	21/54
	NEMA	Type 1/12	Type 1/12
Nominal current rate		190A	250, 310, 400A
Shipping Dimensions	Height (in [mm])	29.5 [750]	34 [864]
	Width (in [mm])	29 [737]	29 [737]
	Depth (in [mm])	76.5 [1943]	86.7 [2203]
	Weight (lbs [kg]):	13.4 [340]	19.7 [500]
Filter Dimensions	Height (in [mm])	68.5 [1740]	78.7 [2000]
	Width (in [mm])	23.6 [600]	23.6 [600]
	Depth (in [mm])	15 [380]	19.4 [494]
	Max weight (lbs [kg])	646 [293]	1010 [458]

4.3 Mechanical Installation

Preparation of the mechanical installation of the filter must be done carefully to ensure a proper result and to avoid additional work during installation. Start taking a close look at the mechanical drawings in 4.2.5 *Mechanical Dimensions* to become familiar with the space demands.

4.3.1 Tools Needed

To perform the mechanical installation, the following tools are needed:

- Drill with 0.39 or 0.47 in [10 or 12 mm] drill bit.
- Tape measure
- Screw driver
- Wrench with relevant metric sockets (7–17mm)
- Wrench extensions
- Sheet metal punch for conduits or cable connectors
- Lifting bar to lift the unit (rod or tube max. Ø 1 in [25mm], able to lift minimum 2204 lbs [1000 kg]).
- Crane or other lifting aid to place the unit in position
- Torx T50 tool

4.3.2 General Considerations

Space

Ensure proper space above and below the unit to allow airflow and cable access. In addition, space in front of the unit must be considered to allow the panel door to be opened.

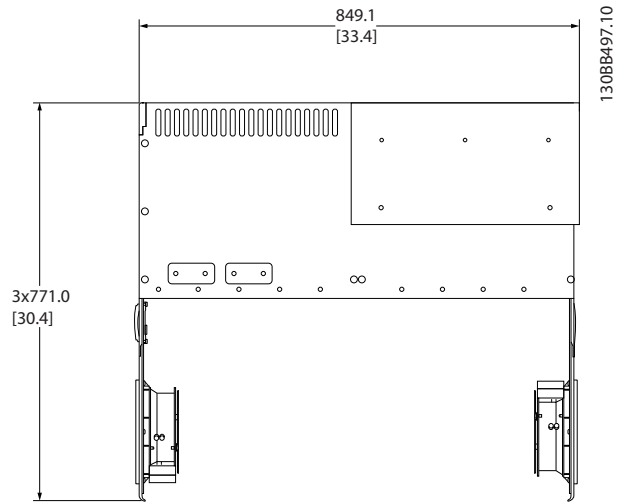

Figure 4.8 Space in front of IP21/IP54 enclosure type, frame size D9.

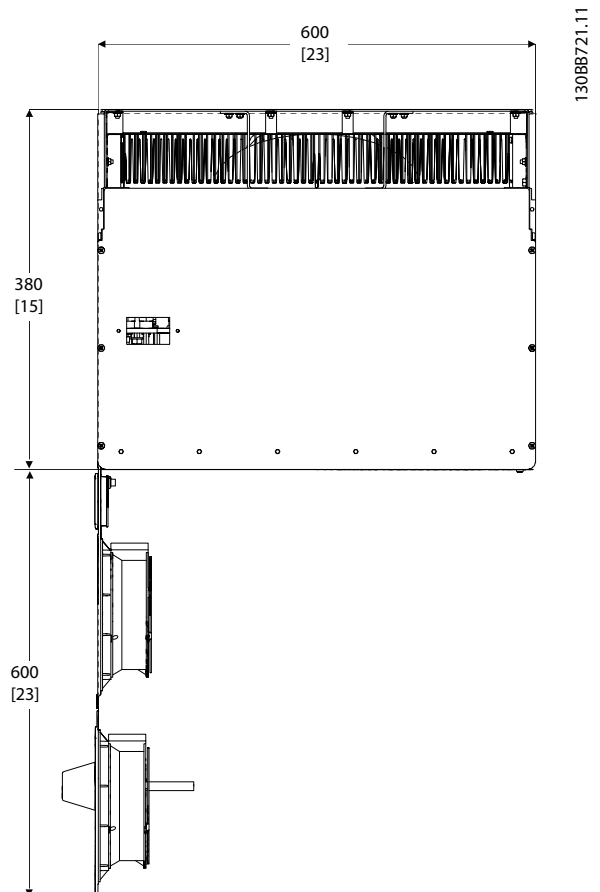

Figure 4.9 Space in front of IP21/IP54 enclosure type, frame size D13.

4

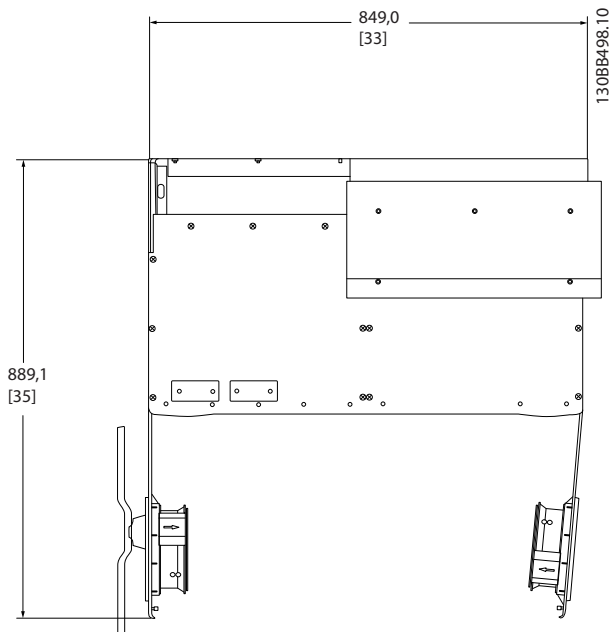

Figure 4.10 Space in front of IP21/IP54 enclosure type, frame size E7.

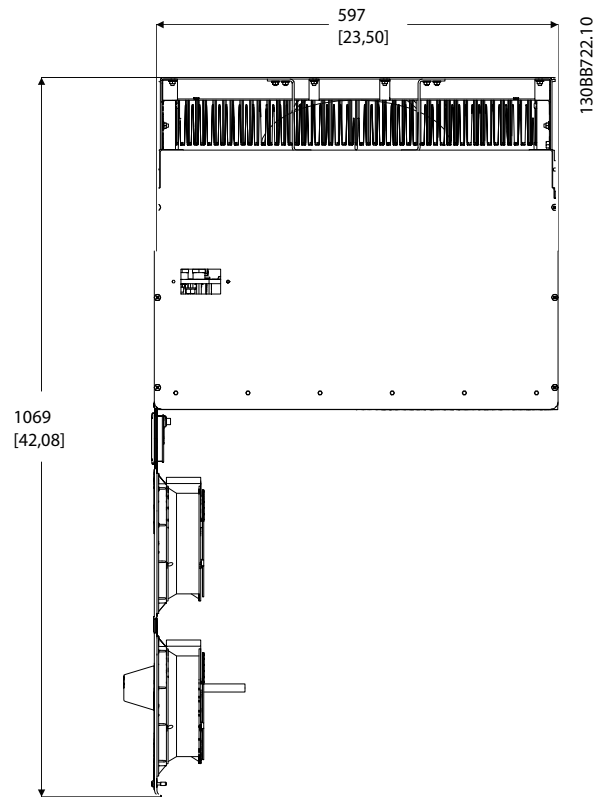

Figure 4.11 Space in front of IP21/IP54 enclosure type, frame size E9.

Wire access

Ensure that proper cable access is present including the necessary bending allowance.

NOTE!

All cable lugs/shoes must mount within the width of the terminal bus bar.

4.3.3 Terminal Locations - Frame size D

Consider the following position of the terminals when designing for cables access.

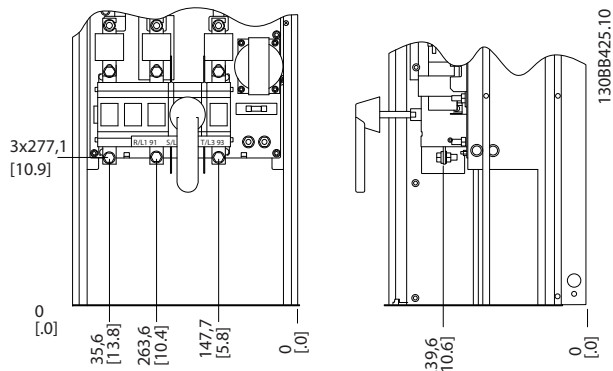

Figure 4.12 Terminal Location of Frame D9

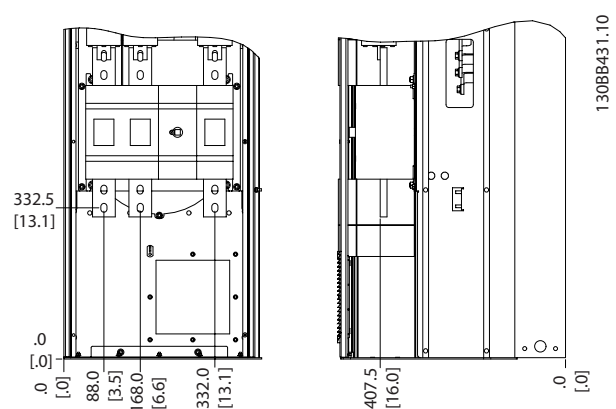

Figure 4.14 Terminal Location of Frame E7

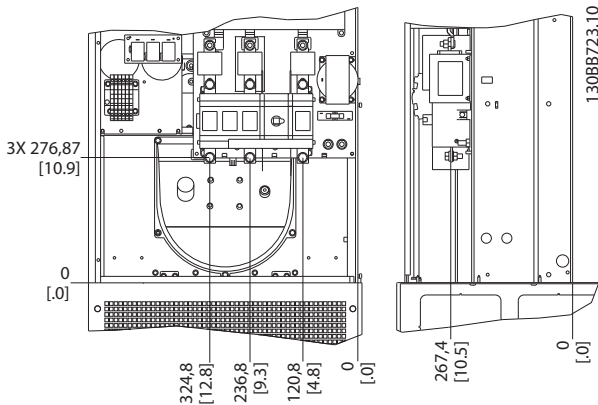

Figure 4.13 Terminal Location of Frame D13

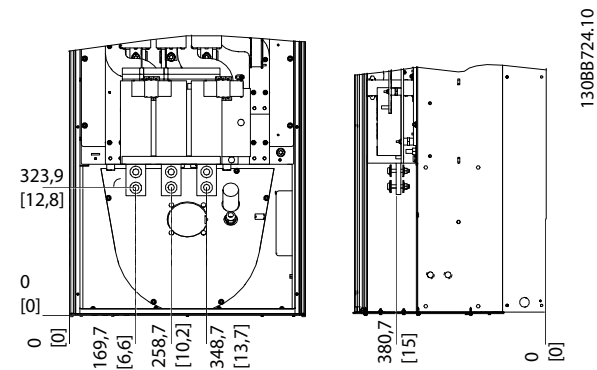

Figure 4.15 Terminal Location of Frame E9

Be aware that the power cables are heavy and hard to bend. Consider the optimum position of the unit for ensuring easy installation of the cables.

4.3.4 Terminal Locations - Frame size E

Give thought to the following terminal positions when designing the cable access.

NOTE!

Note that the power cables are heavy and difficult to bend. Consider the optimum position of the unit for ensuring easy installation of the cables.

Each terminal allows for the use of up to 4 cables with cable lugs or the use of standard box lug. Ground is connected to relevant termination point in the unit.

4.3.5 Cooling and Airflow

Cooling

Cooling can be obtained in different ways, by using the cooling ducts in the bottom and the top of the unit, by taking air in the back of the unit or by combining the cooling possibilities.

Back cooling

The design of the active filter is built on a back channel cooling system where 85% of all heat is ducted via an IP54 segregated back channel. This reduces the needed airflow inside the enclosure and ensures less moist and dust ventilation across vital components.

The back channel air is normally ventilated via the plinth inlet and ducted out the top of the enclosure. The design of the back channel does, however, also allow air to be taken from outside the control room and dusted back out again. This is supported to ease stress on the control room air conditioner and so conserve energy. To support back wall inlet, the unit air inlet has to be blocked via an optional cover and the air outlet ducted via an optional top duct.

NOTE!

A door fan is required on the enclosure to remove the heat losses not contained in the back channel of the unit and any additional losses generated from other components installed inside the enclosure. The total required air flow must be calculated so that the appropriate fans can be selected. Some enclosure manufacturers offer software for performing the calculations (e.g., Rittal Therm software).

Airflow

The necessary airflow over the heatsink must be ensured. The flow rate is shown below.

Enclosure	IP21 / IP54	IP21/54
Frame size	D13/D9	E9, E7
Door fan	340m ³ /h (200 cfm)	340m ³ /h (200 cfm)
Heatsink	765m ³ /h (450 cfm)	1230m ³ /h (725 cfm)

Table 4.1 Heatsink Air Flow

NOTE!

For the active filter, the fan runs for the following reasons:

1. Active filter running
2. Specific heatsink temperature exceeded (power size dependent)
3. Specific Power Card ambient temperature exceeded (power size-dependent)
4. Specific Control Card ambient temperature exceeded

Once the fan is started, it will run for a minimum of 10 minutes.

External ducts

If additional duct work is added externally to the Rittal cabinet, the pressure drop in the ducting must be calculated. Use the charts below to derate the unit according to the pressure drop.

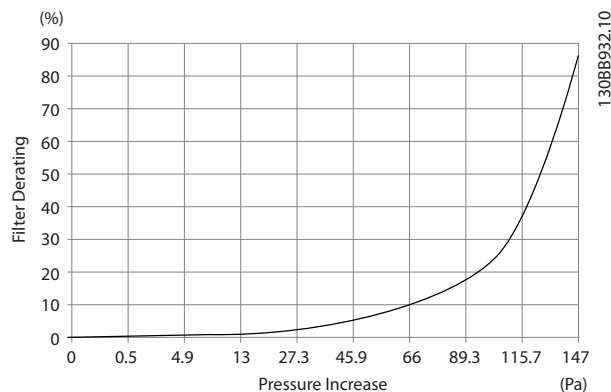

Figure 4.16 D frame Derating vs. Pressure Change
Air flow: 450 cfm (765 m³/h)

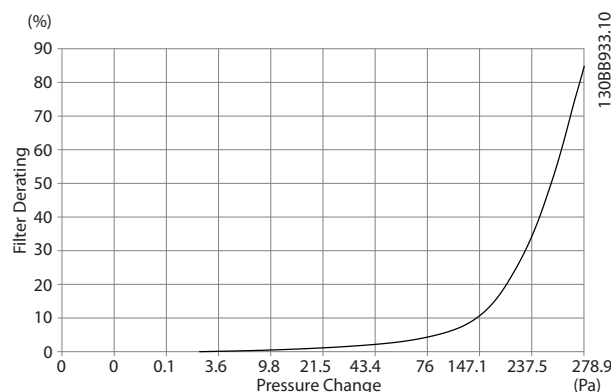

Figure 4.17 E frame Derating vs. Pressure Change
Air flow: 725 cfm (1230m³/h)

4.3.6 Connector/Conduit Entry - IP21 (NEMA 1) and IP54 (NEMA12)

Cables are connected through the gland plate from the bottom. Remove the plate and plan where to place the entry for the connectors or conduits. Prepare holes in the marked area on the drawing.

NOTE!

The connector plate must be fitted to the active filter to ensure the specified protection degree, as well as ensuring proper cooling of the unit. If the connector plate is not mounted, the unit may trip on Alarm 69, Pwr. Card Temp

Cable entries viewed from the bottom of the filter

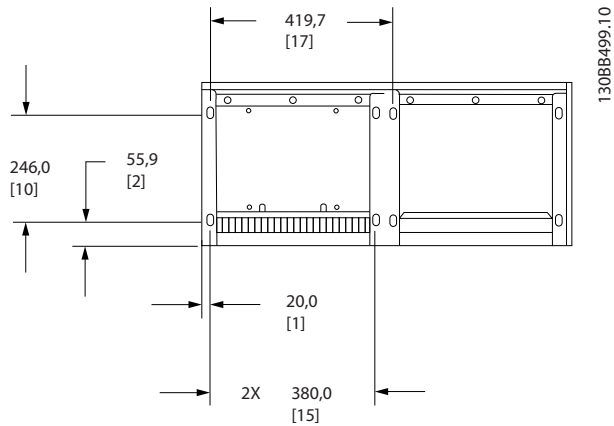

Figure 4.18 Frame Size D9

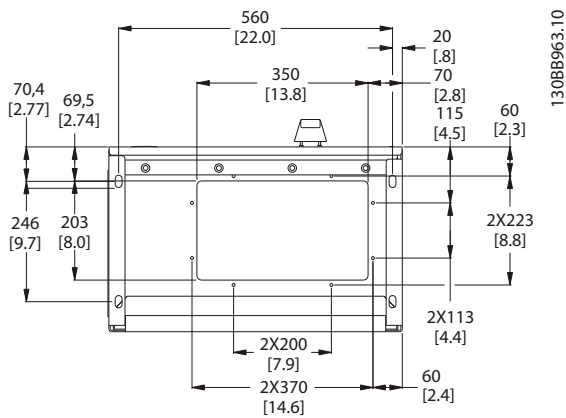

Figure 4.19 Frame Size D13

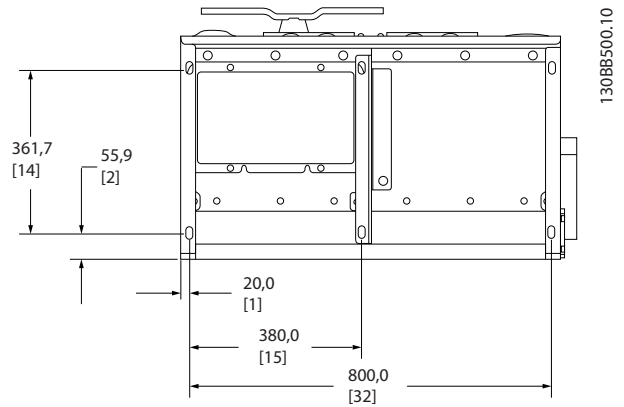

Figure 4.20 Frame Size E7

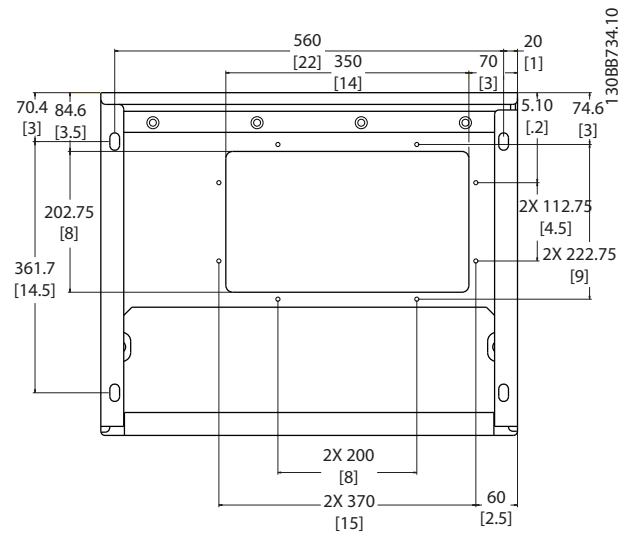
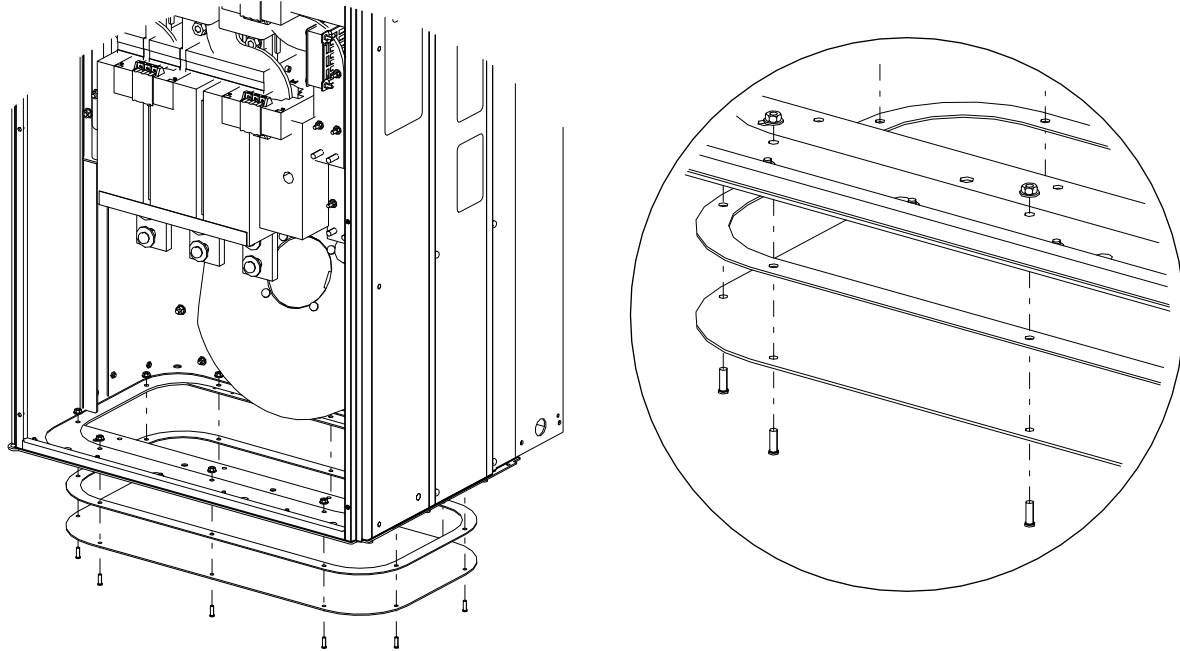

Figure 4.21 Frame Size E9



130BB736.10

Figure 4.22 Mounting of bottom plate, E

The bottom plate of the E frame can be mounted from either inside or outside of the enclosure, allowing flexibility in the installation process, i.e., if mounted from the bottom the connectors and cables can be mounted before the unit is placed on the pedestal.

4.4 Field Installation of Options

4.4.1 Installation of Input Plate Options

This section is for the field installation of input option kits available for active filters.

Do not attempt to remove RFI filters from input plates. Damage may occur to RFI filters if they are removed from the input plate.

	Fuses	Disconnect and Fuse	RFI	Fuses & RFI	Fuses, RFI & Disconnect	None
D9	177G2348	177G2344	177G2346	177G2347	177G2343	177G2345
E7	176F0253	176F0255	176F0257	176F0258	176F0260	
D13	177G2348	177G2344	177G2346	177G2347	177G2343	177G2345
E9	176F0253	176F0255	176F0257	176F0258	176F0260	

4.5 Electrical Installation

4.5.1 Power Connections

Cabling and fusing

NOTE!

Cables General

All cabling must comply with national and local regulations on cable cross-sections and ambient temperature. UL applications require 167°F [75°C] copper conductors. 7167°F [75°C] and 194°F [90° and 90 °C] copper conductors are thermally acceptable for use in non-UL applications.

The power cable connections are situated as shown below. The AC line input connections are fitted to the line power switch if this is included. Dimensioning of the cable cross-section must be done in accordance with the filter current rating including skin and proximity effects, derating and local legislation.

The line power supply must be connected to terminals 91, 92 and 93. Ground is connected to the terminal to the right of terminal 93.

Terminal No.	Function
91, 92, 93	Line power R/L1, S/L2, T/L3
94	Ground

The conductor predominantly carries currents of high frequencies so the current distribution is not evenly dispersed throughout the conductor cross-section. This is due to two independent effects known as skin effect and proximity effect. Both effects make derating necessary and,

Filter	Min CU wire	Min ALU wire	Max wire
190A	70mm ² (2/0)	95mm ² (3/0)	2*150mm ² (2*300MCM)
250A	120mm ² (4/0)	150mm ² (300MCM)	4x240mm ² (4x500MCM)
310A	240 mm ² (500MCM)	2*95mm ² (2*3/0)	4x240mm ² (4x500MCM)
400A	2*95mm ² (2*3/0)	2*150mm ² (2*300MCM)	4x240mm ² (8x900MCM)

Table 4.2 Allowed Active Filter Line Cable with Typical Cable Manufacturer Data

consequently, the line power wire of the active filters must be rated at a higher current than the filter rating itself.

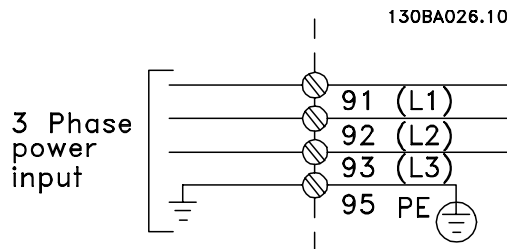

NOTE!

It is insufficient to rate the power cable for the filter current rating alone due to skin and proximity effects.

The required derating is calculated as two separate factors: one for the skin effect and one for the proximity effect. The skin factor depends on the conduction frequency, cable material and cable dimensions. The proximity effect depends on the number of conducts, diameters and the distance between the individual cables.

The optimized line power wire is:

- Copper wires
- Single conducts
- Bus bars

The reason for this is that copper has a lower skin effect factor than aluminum. Bus bars have a greater surface area compared to cables, which also reduces the skin effect factor. The proximity effects of single conduction are negligible.

The following cables specifications take both skin and proximity effects into account:

Due to the built-in LCL filter, the unit will not feed the main wire with high dU/dt signals. That reduces the radiated emission through the power cable. Cable screen can thus be omitted, allowing the line cables to be connected without considering EMC requirements.

The active filter will be able to operate on long cable runs. Cable length is limited by the voltage drop. It is advised to keep the cable lengths below 656 ft [200 m].

4

To protect the active filter, the recommended fuses must be used or the unit must have built-in fuses. Recommended fuses can be seen in the tables of the fuse section. Always ensure that proper fusing is done according to local regulations.

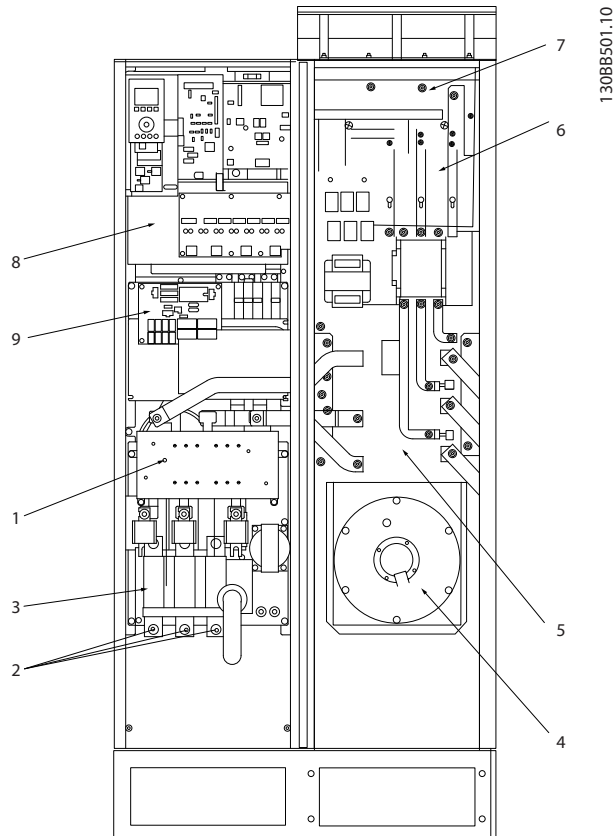

Figure 4.23 Frame size D9

1)	RFI			5)	LCL line reactor
2)	Line power wire connection			6)	LCL capacitors
	R	S	T	7)	LCL filter reactor
	L1	L2	L3	8)	CT wire connection point
3)	Input plate			9)	Fan/SMPS fuse
4)	Back channel fan				

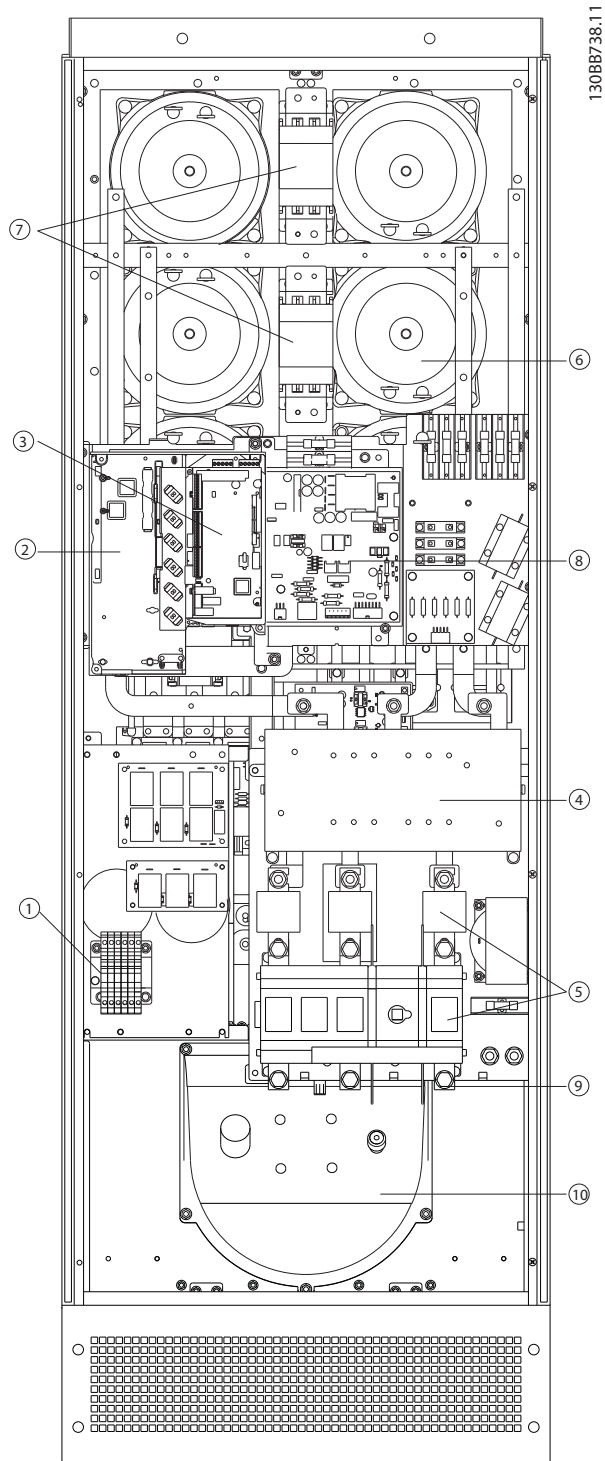

Figure 4.24 Frame size D13

1)	CT - connection terminal	7)	Line power contactor
2)	FC card	8)	Power card
3)	AFC card	9)	Line power wire connection
4)	RFI (input option plate)	10)	Back channel
5)	Fuse/disconnect (line power option)	11)	LCL circuitry
6)	LCL circuitry	12)	DC capacitors

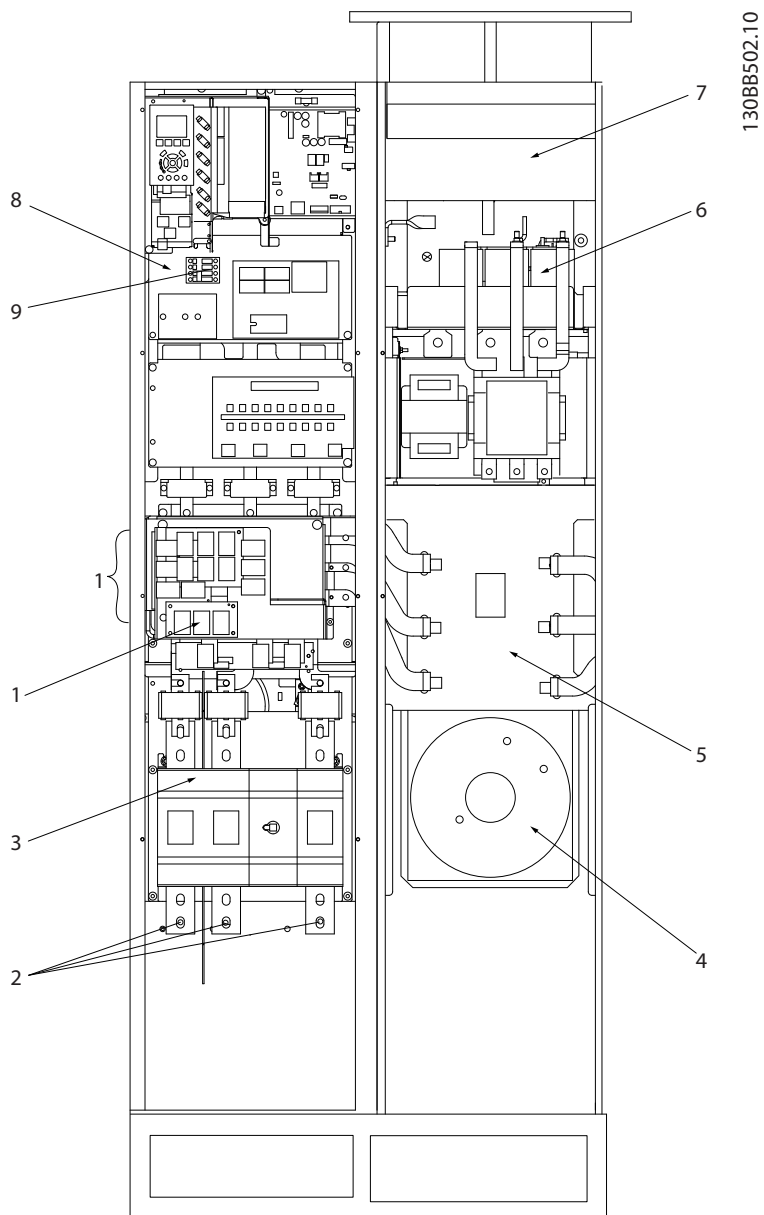
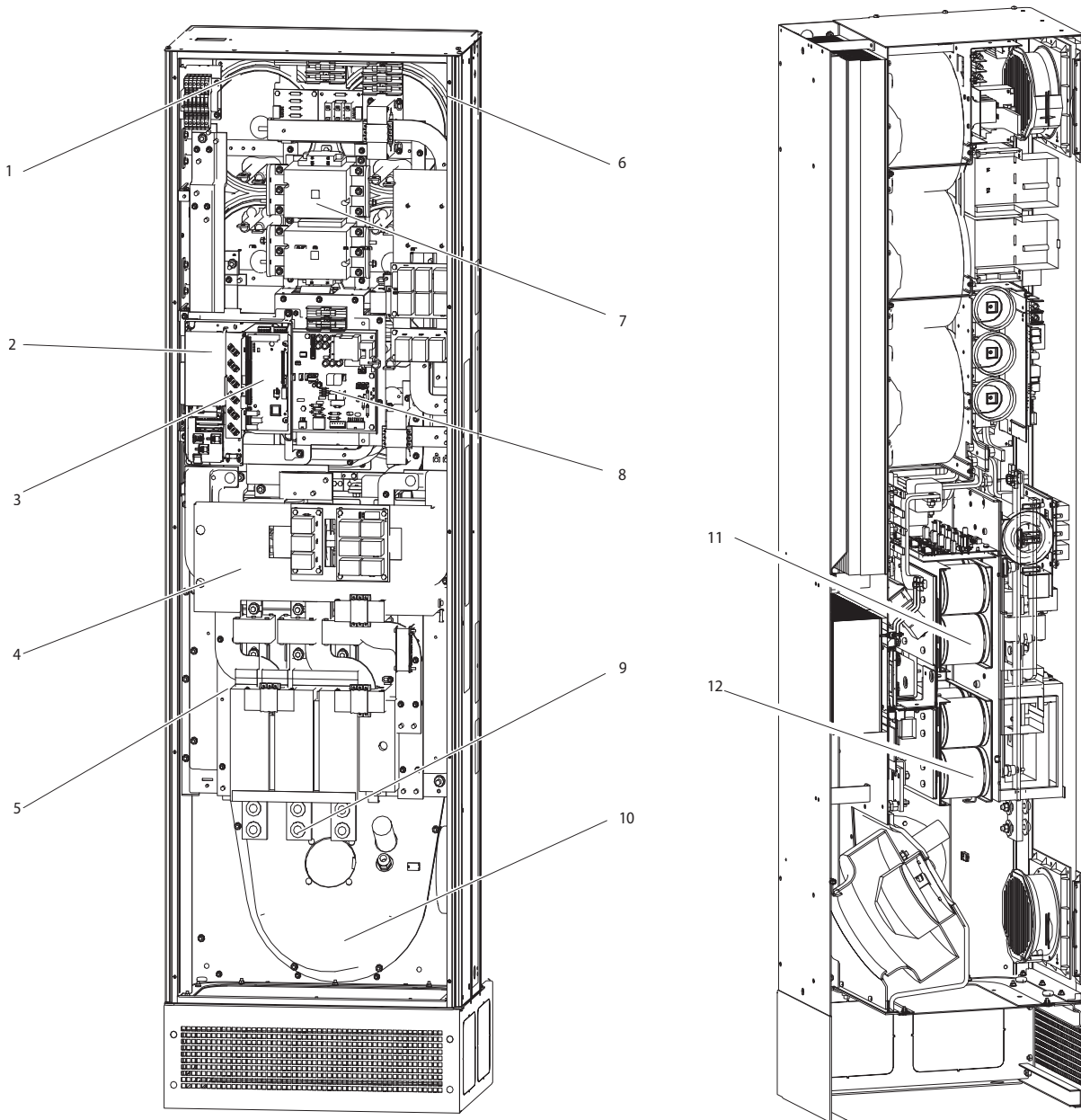

Figure 4.25 Frame size E7

1)	RFI			5)	LCL line reactor		
2)	Line power wire connection			6)	LCL capacitors		
	R	S	T	7)	LCL filter reactor		
	L1	L2	L3	8)	CT wire connection point		
3)	Input plate			9)	Fan/SMPS fuse		
4)	Back channel fan						



1308B740.10

Figure 4.26 Frames Sizes E9

1)	CT - connection terminal	7)	Line power contactor
2)	FC card	8)	Power card
3)	AFC card	9)	Line power wire connection
4)	RFI (input option plate)	10)	Back channel
5)	Fuse/disconnect (line power option)	11)	LCL circuitry
6)	LCL circuitry	12)	DC capacitors

Table 4.3 Frames Sizes D13

4.5.2 Grounding

The following basic issues need to be considered when installing an active filter so as to obtain electromagnetic compatibility (EMC).

- Safety grounding: Please note that the active filter has leakage current and must be grounded appropriately for safety reasons. Always follow local safety regulations.
- High-frequency grounding: Keep the ground wire connections as short as possible.

Connect the different ground systems at the lowest possible conductor impedance. The lowest possible conductor impedance is obtained by keeping the conductor as short as possible and by using the greatest possible surface area. The metal cabinets of the different devices are mounted on the cabinet rear plate using the lowest possible HF impedance. This prevents having different HF voltages for the individual devices and prevents the risk of radio interference currents running in connection cables that may be used between the devices, as radio interference is reduced. In order to obtain a low HF impedance, use the fastening bolts of the devices as HF connections to the rear plate. It is necessary to remove insulating paint and the like from the fastening points.

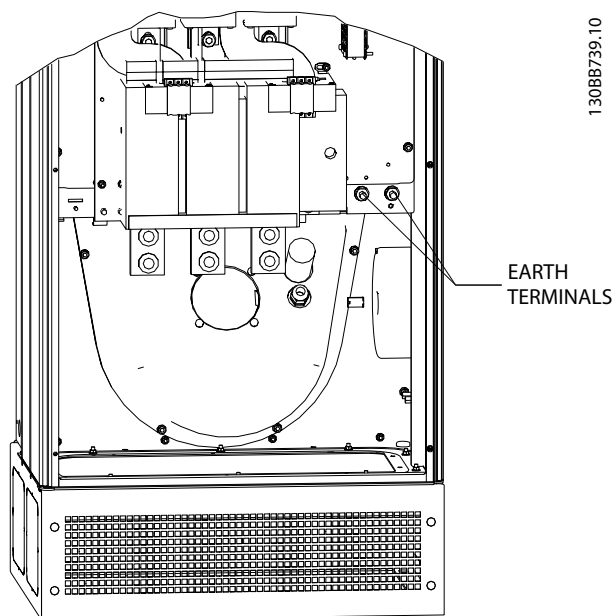

Figure 4.27 Example of Ground Terminal Position

4.5.3 Extra Protection (RCD)

ELCB, RCD, GFCI relays or multiple protective grounding are often used as extra protection, or needed to provide compliance with local safety regulations. In case of a ground fault, a DC component may develop in the fault current. If ELCB relays are used, local regulations must be observed. To ensure effective protection and unintended tripping of protective relays, all relays must be suitable for protection of 3-phase equipment with active current inlet and for a brief discharge during power-up. It is recommended to use a type with adjustable trip amplitude and time characteristics. Select a current sensor with sensitivity of more than 200mA and not less than 0.1 second operation time.

4.5.4 RFI Switch

Line power supply isolated from ground

If the active filter is supplied from an isolated line power source (IT line power, floating delta and grounded delta) or TT/TN-S line power with grounded leg, the RFI switch is recommended to be turned off (OFF 1) via 14-50 RFI Filter on the unit. For further reference, see IEC 364-3. In OFF, the internal RFI capacities between the chassis and the intermediate circuit are cut off to avoid damage to the intermediate circuit and to reduce the ground capacity currents (according to IEC 61800-3). Please also refer to the application note VLT on IT line power, MN.90.CX.02. It is important to use isolation monitors that are capable for use together with power electronics (IEC 61557-8).

4.5.5 Torque

When tightening all electrical connections, it is very important to tighten with the correct torque. Too low or too high torque results in a bad electrical connection. Use a torque wrench to ensure correct torque. Below is the tightening torque required for the line power terminal:

Frame size	Torque	Bolt size
D	19Nm	M10
E	19Nm	M10

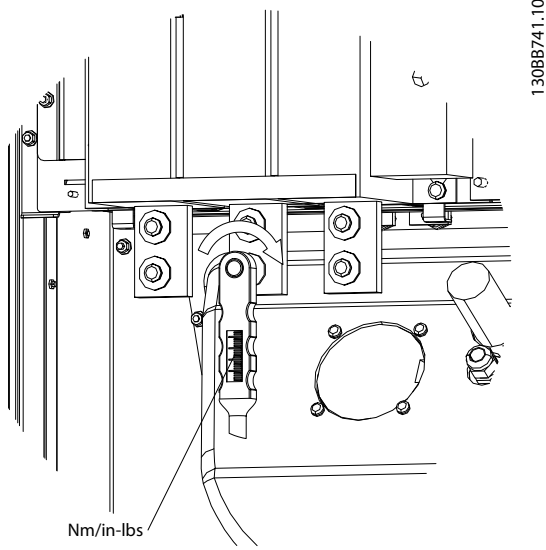

Figure 4.28 Tightening Bolts with Torque Wrench

NOTE!

Always use a torque wrench to tighten the bolts.

4.5.6 Shielded Cables

It is important that shielded cables are connected properly to ensure high EMC immunity and low emissions.

Connection can be made using either cable connectors or clamps:

- EMC cable connectors: generally available cable connectors can be used to ensure an optimum EMC connection.
- EMC cable clamp: Clamps allowing easy connection are supplied with the unit.

4.5.7 Current Transformer (CT)

The filter operates in closed-loop operation by receiving current signals for external current transformers. The received signal is processed and the filter reacts according to programmed actions.

CAUTION

Incorrect current transformer connection, installation or configuration will lead to unintended and uncontrollable behavior of the filter.

NOTE!

The current transformers are not part of the filter package and must be purchased separately.

Current transformer specification

The active filter supports most current transformers. The current transformers must have the following specifications:

Technical specification of active filter passive current transformers:	
RMS	maximum measured RMS current
Accuracy	0.5% or better (Class 0.5)
Rated current	1A or 5A (5A is recommended) Set-up via hardware
Rated frequency	50/60 Hz
Rated power/burden	See Table 4.4 (AAF's burden equal 2mΩ)

Rated power/burden [VA]	5	7.5	10	15	30
Impedance of current CT [Ω]	≤ 0.15	≤ 0.25	≤ 0.35	≤ 0.55	≤ 1.15

Table 4.4 Rated Power/Burden

NOTE!

All other technical data like dynamic rated current, maximal permitted operating voltage, thermal dimensioning of continuous current, thermal dimensioning of short-time current, overcurrent limit, isolation class, working temperature range, etc. are specific values of the system and must be defined during the project planning phase of the equipment.

RMS Specification

The minimum RMS has to be determined by the total current that passes through the current transformer. It is important that the current sensor is not too small, which would lead to sensor saturation. Add 10% margin and pick the next larger standard RMS rate. It is advised to use current transformers with an RMS rating close to the maximum current that flows through it to allow the highest possible accuracy of the measurement and, as a result, ideal compensation.

CT Burden

In order to ensure that the current transformer performs according to specifications, the rated burden should not be above the true current requirement by the active filter. The burden of the CT depends on the wire type and the cable length between the CT and the filter CT connection terminal. The filter itself contributes with 2mΩ.

NOTE!

The accuracy of the CT depends on the wire type and length of the cable between filter and current transformer.

The required (minimum) CT burden can be calculated as:
 $[VA] = 25 * [Ohm/M] * [M] + 1.25$
 [Ohm/M] being the cable resistance in Ohm/meter, [M] being the cable length in meters

Table 4.5 shows the minimum CT burden for different wire gauge at wire length of 164 ft [50 m] and standard wire resistance value:

Wire Gauge [mm2 / AWG]	Resistance [Ohm/Km]	Wire length [meters / feet]	Minimum CT burden [VA]
1.5 / #16	13.3	50 / 164	>16.6
2.5 / #14	8.2	50 / 164	>10.2
4 / #12	5.1	50 / 164	> 6.3
6 / #10	3.4	50 / 164	> 4.2
10 / #8	2	50 / 164	> 2.5

Table 4.5 Minimum CT Burden

For a fixed CT burden, the maximum allowed wire length can be calculated as:
 $[M] = ([VA] - 1.25) / (25 * [Ohm/M])$

Below is the maximum wire length of CT with 2.5mm² wires and resistor value equal 8.2 Ohm/km:

Wire Gauge [mm2 / AWG]	Resistance [Ohm/Km]	Minimum CT burden [VA]	Wire length [meter / feet]
2.5 / #14	8.2	5	<18m / 60
2.5 / #14	8.2	7.5	<30m / 100
2.5 / #14	8.2	10	<42m / 140
2.5 / #14	8.2	15	<67m / 220
2.5 / #14	8.2	30	<140m / 460

Example

Calculation example for correct current transformer for an application with:

RMS= 653Amp, Distance between filter and CTs of 98 ft [30 m].

$RMS = 653 * 1.1 = 719A$, CT RMS = 750Amp. Burden :
 $30m @ 2.5mm^2 \text{ wire} \Rightarrow 25 * 0.0082 * 30 + 1.25 = 7.4 \Rightarrow 7.5 [VA]$.

Current transformer installation

The unit only supports three CT installations. External CTs should be installed on all three phases to detect the harmonic content of the grid. The flow direction of the sensor is in most cases indicated by an arrow. The arrow should point in the direction of the current flow and thus towards the load. If the flow direction is programmed incorrectly, the polarity can be changed via filter 300-25 CT

Polarity. 300-25 CT Polarity can program the polarity of all three phases individually.

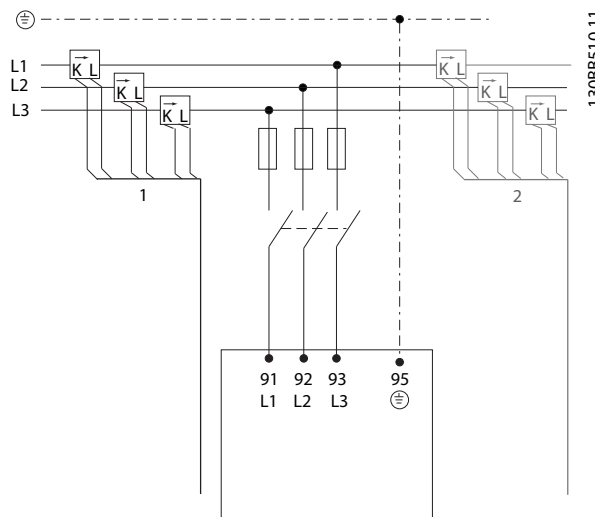

1 or 5 Amp CT Set-up

To allow for possible reuse of already present CT transformers, the VLT Active Filter allows use of either 1 Amp or 5 Amp CTs. The filter is as standard set-up for 5 Amp CT feedback. If the CTs are 1 Amp, redirect the CT terminal plug from slot MK101, pos. 1, to MK108, pos. 2, on the AFC card; see Figure 4.29.

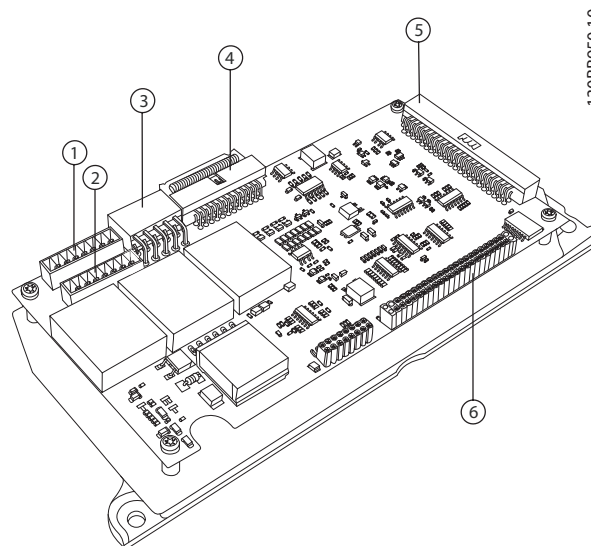

Figure 4.29 AFC Board

Individual or group compensation

The compensation of the filter depends on the signal that is returned from the current transformers. The point of installation for these sensors thus determines the loads that are corrected.

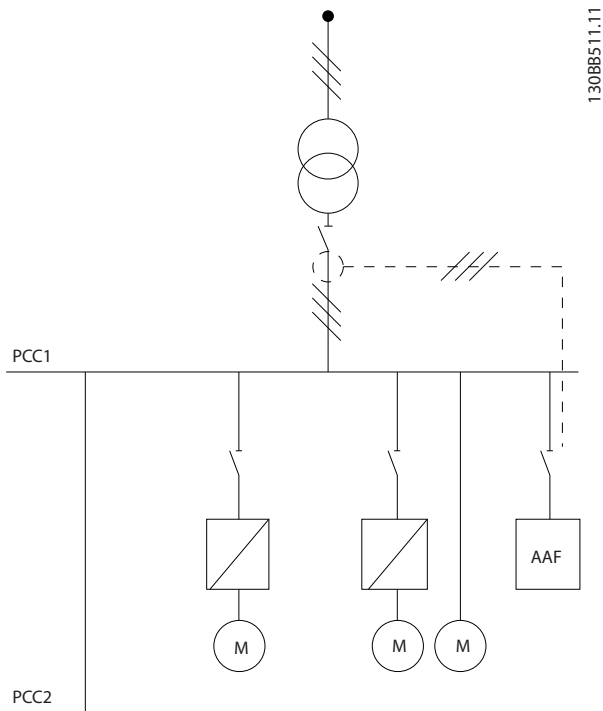

Figure 4.30 Current transformers installed in front of the entire installation and filter compensate all loads on the transformer (CT on PCC side).

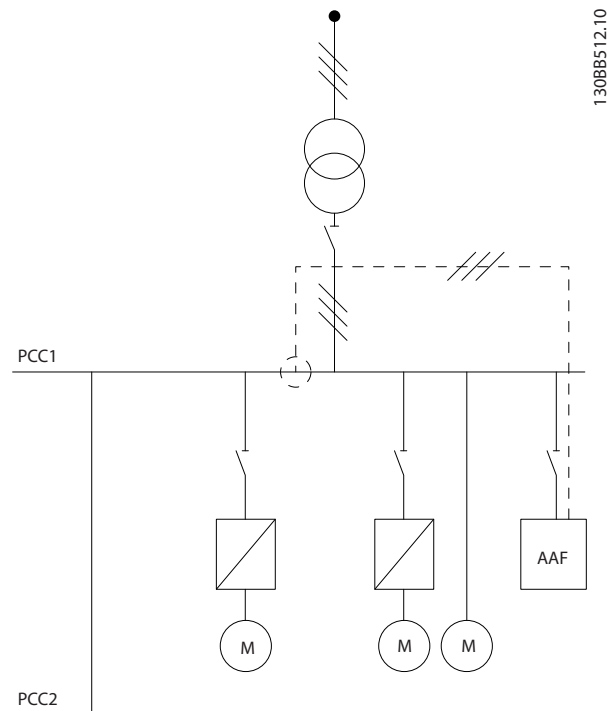
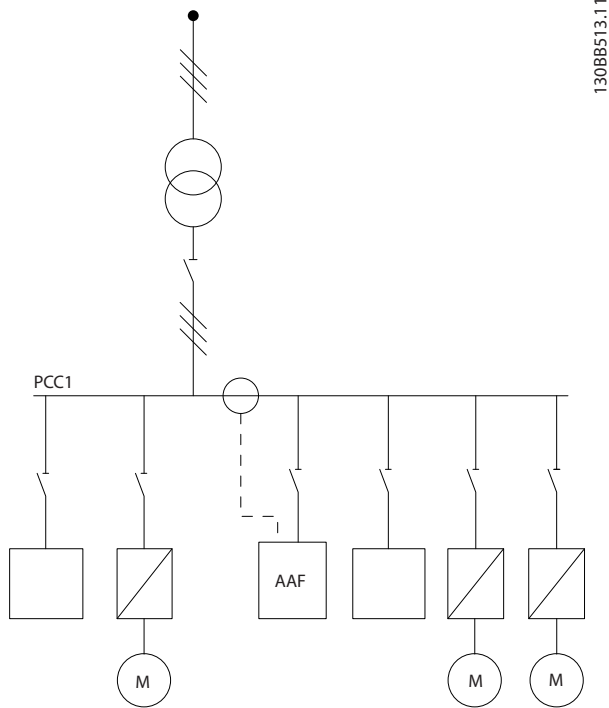

Figure 4.31 Current transformers are installed in front of distribution bus 2 and 1, Adjustable frequency drive and the filter only compensates currents for those (CT on load side).

If the CTs are installed on the secondary side of the transformer and thus in front of the entire load, the filter will compensate all loads simultaneously. If, as in *Figure 4.31*, the CTs are installed in front of only some of the loads, the filter will not compensate unwanted current deformation of the Adjustable frequency drive and motor on the right hand side. If CTs are installed in front of a single load, the filter will only compensate the one load and so form individual load compensation. The filter can be programmed to have CTs installed on source side also called Point of Common Coupling (PCC) or alternatively at the load side. This must be programmed via *300-26 CT Placement*

NOTE!

By default, filter is programmed for PCC side installation



130BB513.11

Figure 4.32 Current transformers installed on source (PCC) side for group compensation.

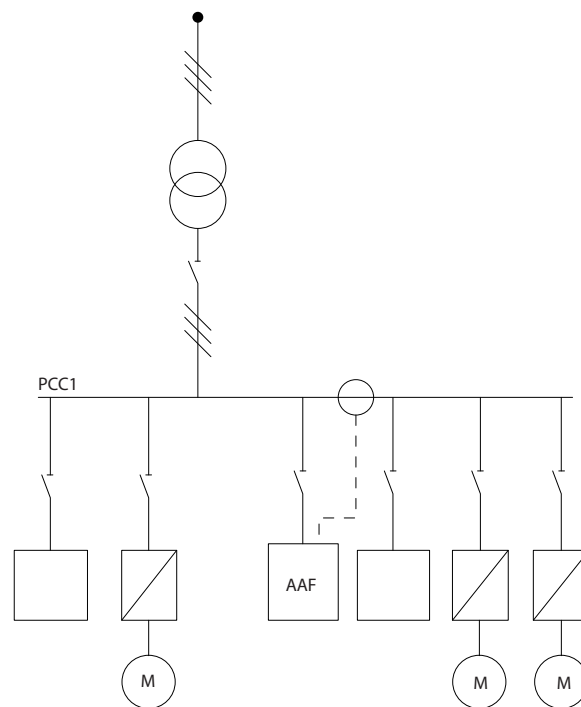

130BB514.11

Figure 4.33 Current transformers installed on load side for group compensation.

If the current transformers are installed on the source (PCC) side, the filter will expect a sinusoidal (corrected) signal feedback from the three sensors. If the sensors are installed on the load side, the received signal will be subtracted from the ideal sine wave to calculate the needed corrected current.

NOTE!

Erratic filter operation can be a result of incorrect current transformers connection point programming *300-26 CT Placement*

4.5.8 Auto CT Detection

The VLT Active Filter is able to perform an auto detection of the installed CT. The CT auto detection can be conducted both while the system is running and at no load conditions. The filter injects a prefixed current of known amplitude and phase angle and measures the returned CT input. The performance is conducted on each phase individually and for several frequencies to ensure phase sequence and RMS are set correctly.

The Auto CT detection is pending on the follow conditions:

- Active Filter bigger than 10% of CT RMS rate
- CTs installed on source (PCC) side (auto CT not possible for load side CT installation)
- Only one CT per phase (not possible for summation CTs)
- CTs are part of below standard range:

						600	750
1000	1250	1500	2000	2500	3000	3500	4000

Table 4.6 Primary Rating [A]

Most restrictions on the current transformers comes from the installation, such as necessary cable length, temperature conditions, square section of conducts, standard or split core layout, etc. A broad range of different current transformers can be used independently of brand and type.

For specific CT requirements contact the local supplier or go to

http://www.deif.com/Download_Centre/Search.aspx?search-string=dct:

Secondary	Primary	Accuracy	Burden	Type	Description
5 or 1A	30–7500A	0.2–0.5-1	1.0–45V A	ASR ASK EASR EASK	Measuring current transformer for cables and bus bars
5 or 1A	100–5000A	0.5–1	1.25–30V A	KBU	Split core current transformer
5 or 1A	5 or 1A	0.5–1	15–30V A	KSU/ SUSK	Summation current transformer

Table 4.7 Standard CT Range from Deif - Fits Most Applications

4.5.9 Summation Transformers

Multiple current sources:

If the filter is to compensate current from several sources, summation CTs need to be installed. This is often the case if the filter is installed in systems with a generator backup or where the filter is only to compensate a limited number of loads.

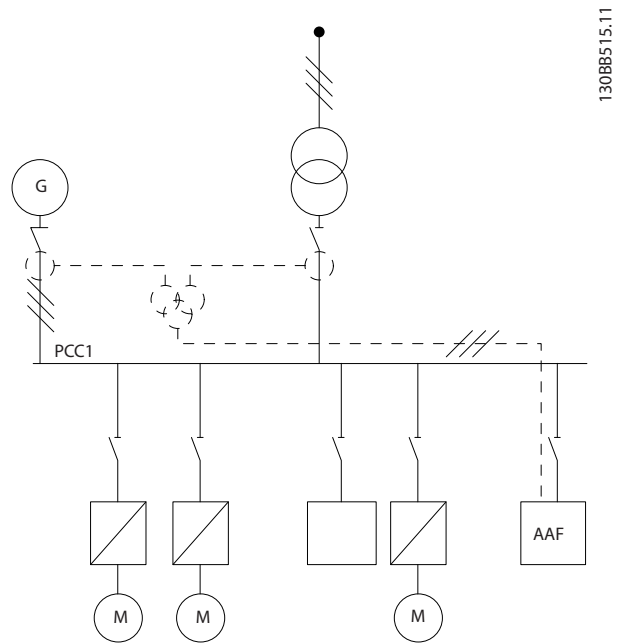

130BB515.11

Figure 4.34 Summation CTs on generator backup applications (PCC-side). Filter compensates full current of transformer and generator.

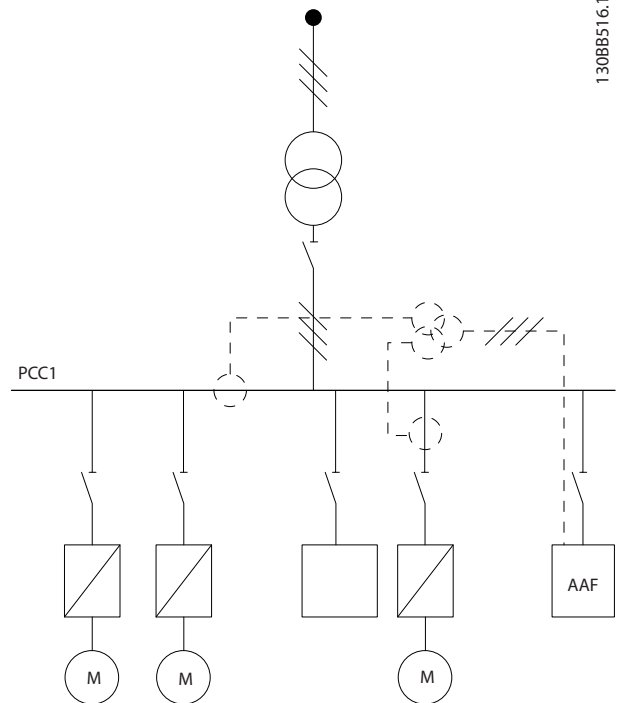

130BB516.11

Figure 4.35 Summation CTs example for individual harmonic compensation (load side).

Summation current transformers are available with multiple (2-5) inputs and common output. For applications where summations CTs are used to add current from several sources, make sure that all CTs connected to the summation are from the same manufacturer and that the CT have the following:

- The same polarity
- The same primary rate
- The same RMS value
- The same accuracy (class 0.5)
- The same location (PCC or load-side)
- The same phase sequence

NOTE!

Use summation CT with great caution and always ensure correct phase sequence, current direction, primary and secondary rate. If installation is incorrect the filter will not work according to expectations.

The current transformer's burden calculation has to include all wires in the installation and must be conducted for the longest total wire string when using summation CTs.

4.5.10 Active Filter Operating with Capacitor Banks

The VLT Active Filter is able to run in conjunction with capacitor banks as long as the resonance frequency of the capacitor bank is not in the operation range of the active filter.

NOTE!

Always use detuned capacitor banks in installation with Adjustable frequency drive and active filters to avoid resonance phenomena, unintended tripping or even component break down.

For the case of detuned capacitors, the resonance frequency capacitors should be tuned for an inter-harmonic number lower than the third harmonic. The VLT Active Filter has to operate in selective compensation mode if the filter is installed in conjunction with capacitor banks of any kind.

Capacitor bank should ideally be installed upstream from the filter/towards the transformer. If that is not possible, the current transformers should be installed in a way that they do not measure both needed current compensation and the capacitor corrected current.

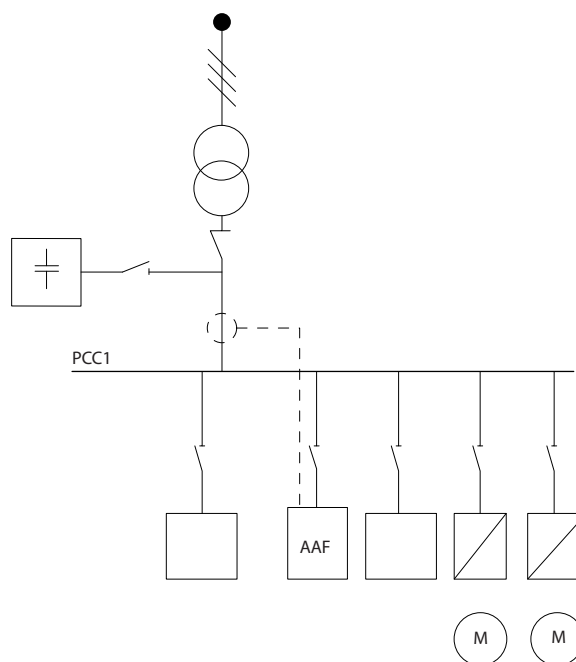

13088517.11

Figure 4.36 Capacitor bank mounted up-stream and CT's installation does not measure capacitor current.

Figure 4.36 shows recommended installation of the active filter and CT placement in installations holding capacitor banks.

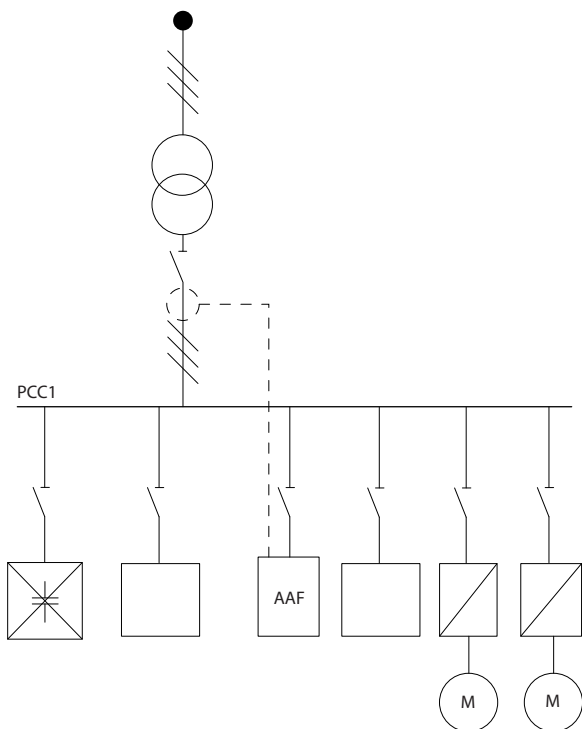

130BB518.11

Figure 4.37 Un-allowed installation. Corrected capacitor current interacts with CT measurement.

For installations where the CT connection point can be moved, *Figure 4.38* is also possible. In some retrofit applications, summation CT is needed to ensure that the capacitor current is not measured.

Summation CT can also be used to subtract two signals from each other, i.e. the capacitor bank corrected current from the total current.

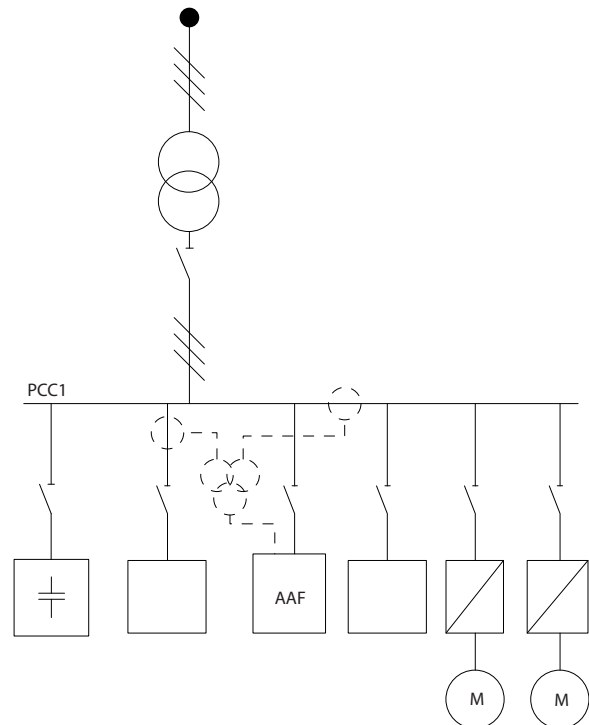

130BB520.11

Figure 4.39 Capacitor bank mounted on PCC, but CTs installed to ensure that capacitor corrected current is not measured.

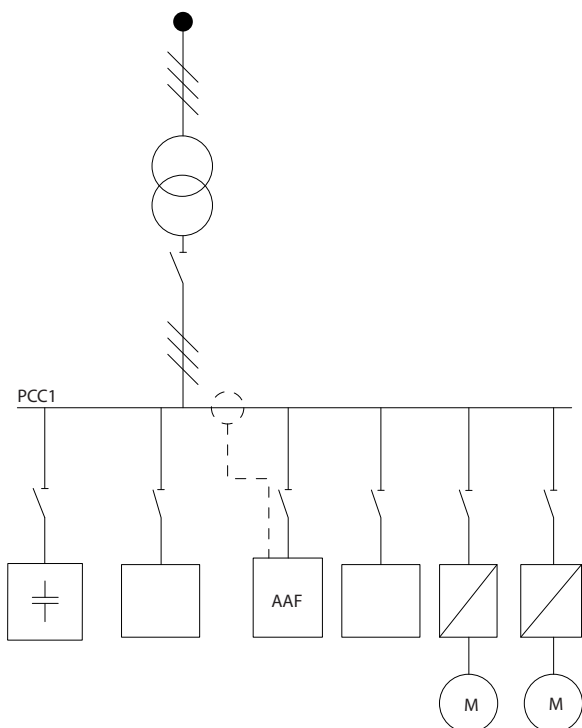

130BB519.11

Figure 4.38 CT installation does not measure capacitor current.

4.5.11 Fuses

Branch circuit protection:

In order to protect the installation against electrical and fire hazard, all branch circuits in an installation, switch gear, machines, etc., must be short-circuited and overcurrent protected according to national/international regulations.

Short-circuit protection:

The active filter must be protected against short-circuit to avoid electrical or fire hazard. Danfoss recommends using the fuses mentioned below to protect service personnel and equipment in case of an internal failure in the device.

Overcurrent protection

The active filter is equipped with an internal overcurrent protection that avoids overload in normal running conditions. Overload protection is however needed in case

of internal failures to avoid fire hazard due to overheating of the cables in the installation. Fuses or circuit breakers can be used to provide the needed protection for the installation. Overcurrent protection must always be carried out according to national regulations.

Supplementary fuses

SMPS Fuse

Frame size	Bussmann PN*	Littelfuse	Rating
D and E	KTK-4		4 A, 600 V

Fan Fuses

Size/Type	Bussmann PN*	Littelfuse	Rating
A190-250A, AAF005	KTK-4		4 A, 600 V
A190 - A400, AAF006		KLK-15	15 A, 600 V

Soft charge resistor fuses

Frame size	Bussmann P/N	Rating
D and E	FNQ-R	1 A, 600 V

Control Transformer fuse

Frame size	Bussmann P/N	Rating
D and E	FNQ-R	3 A, 600 V

4.5.12 Line Power Disconnectors

Frame size	Power & Voltage	Type
D	A190 380–480V	ABB OETL-NF200A
E	A250 380–480V	ABB OETL-NF400A
E	A310 380–480V	ABB OETL-NF400A
E	A400 380–480V	ABB OETL-NF800A

4.5.13 Control and CT Cable Routing

Tie down all control wires to the designated control cable routing as shown in the picture. Remember to connect the shields in a proper way to ensure optimum electrical immunity.

CT connection

Connections are made to the terminal block below the active filter card. The cable must be placed in the provided path inside the filter and tied down with other control wires (see Figure 4.40).

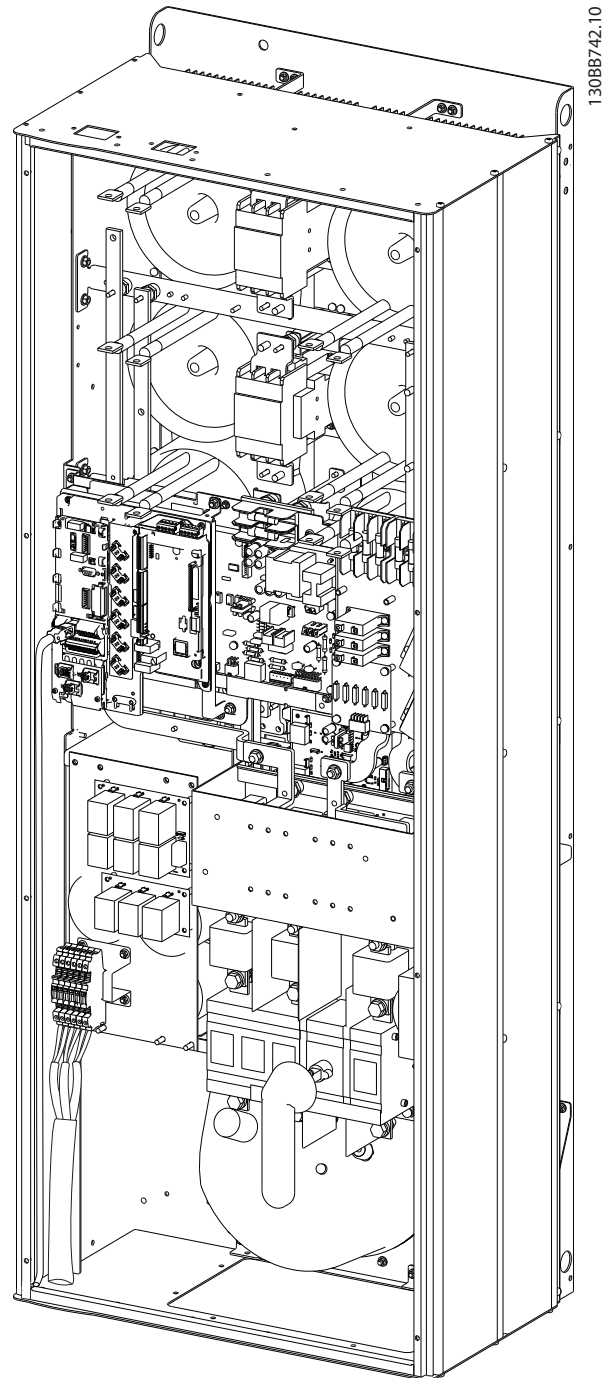

Figure 4.40 Example of Control Card Wiring Path, D13.

4.5.14 Control Wire Installation

All terminals to the control cables are located on the AFC board.

To connect the cable to the terminal:

1. Strip insulation by about 0.34–0.39 in [9–10 mm].

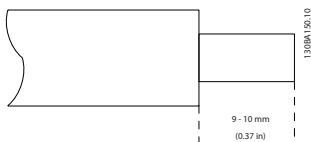

2. Insert a screwdriver¹⁾ in the square hole.

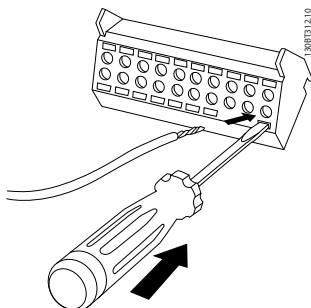

3. Insert the cable in the adjacent circular hole.

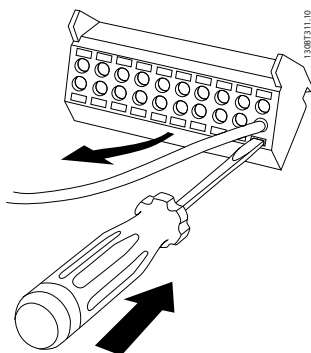

4. Remove the screwdriver. The cable is now mounted in the terminal.

To remove the cable from the terminal:

1. Insert a screw driver¹⁾ in the square hole.
2. Pull out the cable.

1) Max. 0.015 x 0.1 in [0.4 x 2.5 mm]

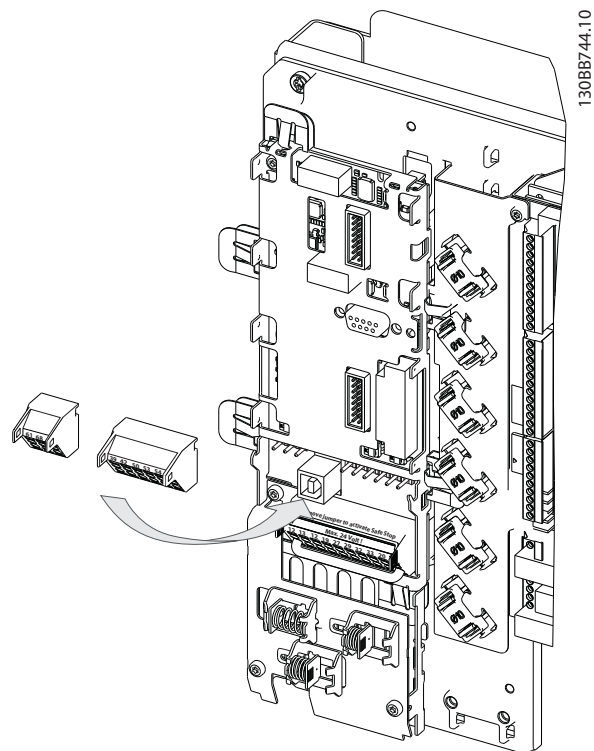

4.5.15 Unshielded Control Wires

CAUTION

Induced Voltage!

Run input power and control wiring in separate metallic conduits or raceways for high frequency noise isolation. Failure to isolate power and control wiring could result in less than optimum controller and associated equipment performance.

Control wiring including CT wires should always be isolated from the high voltage power wiring. When shielded/armored cable is not used, ensure that control wires are twisted pairs and keep the maximum possible distance between line power wire and control cables.

4.5.16 External Fan Supply

If the active filter is supplied by DC or if the fan must run independently of the power supply, an external power supply can be applied.

Terminal No.	Function
100, 101	Auxiliary supply S, T
102, 103	Internal supply S, T

The connector located on the power card provides the AC line voltage connection for the cooling fans. The fans are factory-equipped to be supplied from a common AC line (jumpers between 100-102 and 101-103). If an external supply is needed, the jumpers are removed and the supply is connected to terminals 100 and 101. A 5 Amp fuse should be used for protection. In UL applications this should be Littelfuse KLK-5 or equivalent.

4.6.1 Electrical Installation, Control Cables

4

13088507.11

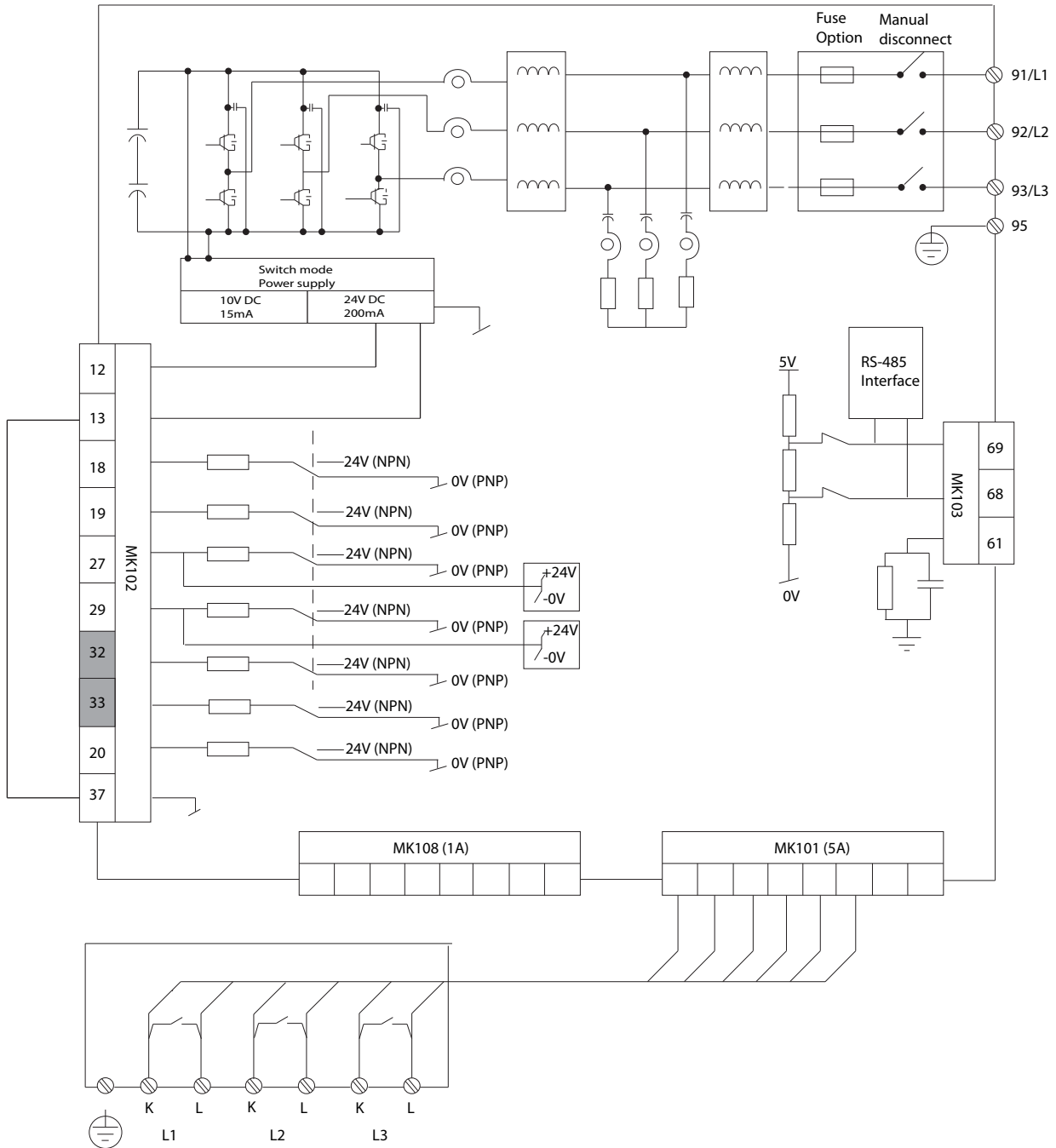

Figure 4.41 Diagram showing all electrical terminals without options.

Terminals L1, L2 and L3 (91,92,93 and 95) are grid connection terminals Terminal 37 is the input to be used for Safe Stop. Grey-scaled terminals are already used for internal operation or are not configurable via software of the active filter.

MK108	1A CT connection pin	MK102	I/O connections
MK101	5A CT connection pin	91-93	Line power input
MK103	Software communication RS-485		

NOTE!

Terminals are not all located on the same PCB.

In rare cases, very long control cables and analog signals may, depending on installation, result in 50/60 Hz ground loops due to noise from line power supply cables.

If this occurs, it may be necessary to break the shield or insert a 100 nF capacitor between shield and chassis.

Input polarity of control terminals

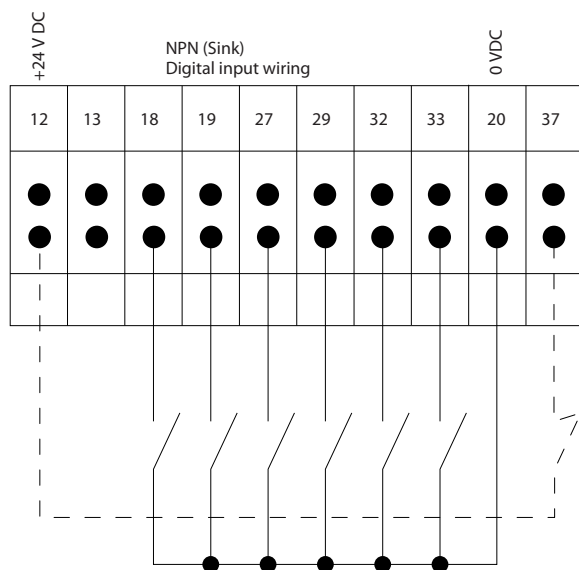
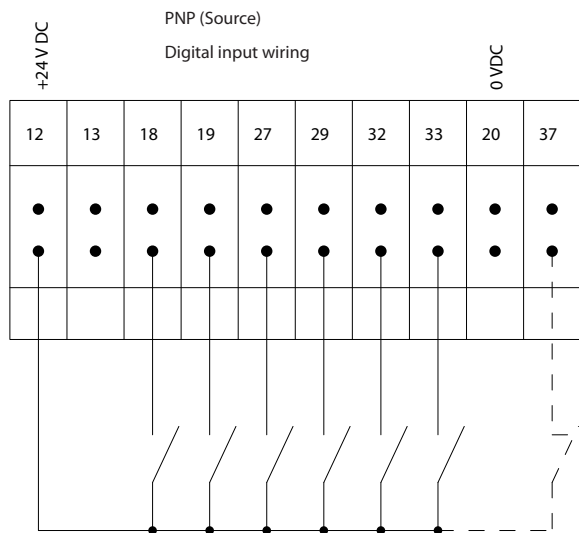

NOTE!

To comply with EMC emission specifications, shielded cables are recommended. If a non-shielded cable is used, see 4.5.15 *Unshielded Control Wires*. If non-shielded control cables are used, it is recommended to use ferrite cores to improve EMC performance.

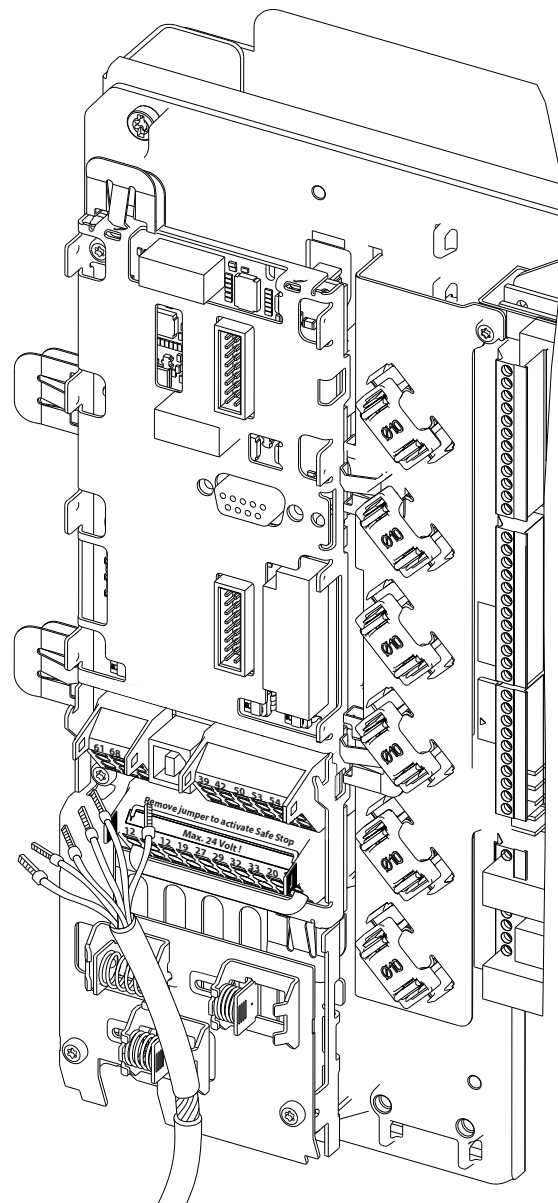

Remember to connect the shields in a proper way to ensure optimum electrical immunity.

4.7 Paralleling of Active Filter Units

The VLT Active Filter is designed to be installed in networks with other active in-feed current suppliers and operate in conjunction with other active filters, UPSs and AFE drives. There are no limitations to the maximum allowed units to be installed. Four filters are allowed to be connected to the same CT input and run in a master-follower configuration. The master unit is activating the individual followers according to mitigation demand in a cascade network. This keeps the switching losses as low as possible and thus improves the system efficiency. The master unit will automatically allocate a new follower in case a unit is out due to service or has unintentionally tripped.

4.7.1 CT wiring for Parallel Filter Connection

VLT Active Filter is designed to allow up to four units to run in parallel allowing for a harmonic and reactive compensation extension to four times the individual filter rating. The parallel installed filters uses the same current input and so only one external set of CTs have to be installed. If additional filtration is needed, additional filters have to use separate current transformers installed up or down stream to the CT signal and injection point of the paralleled installation.

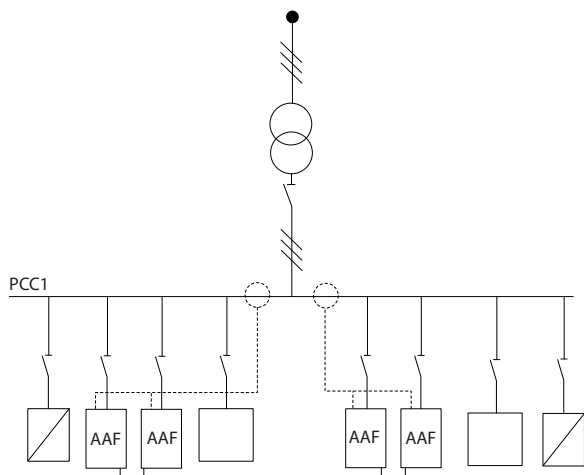

Figure 4.42 Two sets of AAFs in Master-Follower.

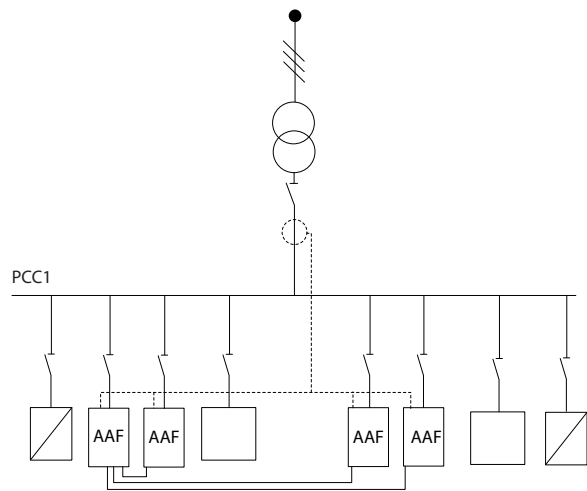

Figure 4.43 Four AAFs in Master-Follower

The parallel connected filters must have the CT input signal wired in serial according to Figure 4.44:

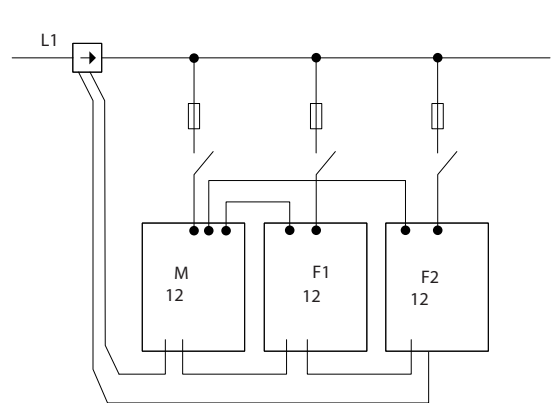

Figure 4.44 Single phase CT connection diagram for master and follower.

CAUTION

All CT wires must be shielded for correct EMC installation. Unshielded cables can lead to noise on the CT wire and result in incorrect harmonic filtration.

The current transformers VA limitation still have to be kept for filters in parallel and so total wires length has to be limited according to wire type and CT VA rating.

$$[M] = ([VA]-1,25) / (25*[Ohm/M])$$

See 4.5.1 Power Connections for more details.

4.7.2 Control Wire Connection for Parallel Filter Run

Additional to the CT wiring, all follower units have to be connected to the master via either digital or analog inputs. The figure below shows the necessary control wire connections:

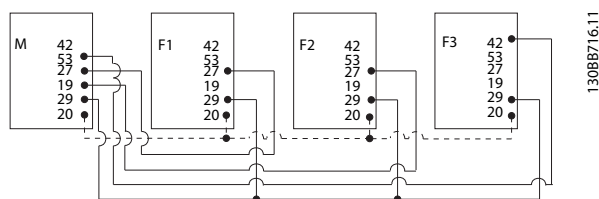

Figure 4.45 Control wire connection of follower units F1-F3 (AAF2-4) to master unit M (AAF1)

The table below shows the necessary connections when less than four units are paralleled. The software set-up of digital and analog in/output will be done automatically according to below table based on software programming 300-40 Master Follower Selection and 300-41 Follower ID.

	Terminal connection at follower	Terminal connection at master
Follower 1 (F1)	27	27
Follower 2 (F2)	27	19
Follower 3 (F3)	42	53
All (parallel)	29	29
All (parallel)	20	20

WARNING

Follower units will not work if control wires are not correctly connected.

NOTE!

It is advised to use shielded control wires for correct EMC installation.

4.7.3 Software Set-up of Parallel Filter Run

It is not practical to have followers running in different mitigation mode or with changed priorities individually, as desired performance cannot be guaranteed. Parallel connected filters are thus always to be programmed with same compensation and priority mode. Also make sure all CT settings have been set identically in all parallel connection units, and all has same hardware secondary CT configuration.

The automatic CT detection is still effective for filters in master-follower configuration but it is recommend setting follower units manually. It is advised to use the following procedure for setting the CT values:

1. Program master unit 300-10 Active Filter Nominal Voltage
2. Program master unit 300-26 CT Placement
3. Perform an automatic CT detection on master unit 300-29 Start Auto CT Detection
4. Note the auto CT result and manually program each follower unit.
5. Ensure identical settings in 300-10 Active Filter Nominal Voltage, 300-26 CT Placement and on each unit.

Alternatively, each follower unit can conduct an automatic CT detection after the master unit is turned off. Only run one auto CT detection at a time.

Additional to above mentioned CT setting it is also necessary to set each unit to have its respective role in the cascade network. 300-40 Master Follower Selection is set to master or follower for each unit.

300-40 Master Follower Selection		
Option:	Function:	
[0]	Master	If operating active filters in parallel, select whether this AF is a master or a follower active filter.
[1]	Follower	
[2] *	Not Paralleled	

WARNING

Make sure only one master is set in each group of parallel connected filters. Verify that no other unit is set to master.

After changing this parameter, additional parameters are accessible. For the master units, 300-42 Num. of Follower AFs must be programmed for the amounts of followers (followers) connected.

300-41 Follower ID		
Range:	Function:	
1*	[1 - 3]	Enter the unique ID of this follower. Verify that no other follower uses the same ID.

NOTE!

300-41 Follower ID is not accessible unless 300-40 Master Follower Selection is set to follower.

⚠ WARNING

Each follower should have its own follower ID. Verify that no other follower has the same follower ID.

300-42 Num. of Follower AFs		
Range:	Function:	
1*	[1 - 3]	Enter the total number of follower active filters. The master active filter will only control this number of followers.

NOTE!

300-42 Num. of Follower AFs is not accessible unless 300-40 Master Follower Selection is set to master.

Each follower unit has to be programmed at *300-41 Follower ID*. The follower IDs need to be different from one another.

Before starting the units (pushing auto-on button), it is advised to check that the following parameters all have been correctly programmed and have similar values for all units sharing one set of CTs:

- 300-00 Harmonic Cancellation Mode*
- 300-20 CT Primary Rating*

- 300-22 CT Nominal Voltage*
- 300-24 CT Sequence*
- 300-25 CT Polarity*
- 300-26 CT Placement*
- 300-30 Compensation Points*
- 300-35 Cosphi Reference*

4.8 Final Set-Up and Test

External CT settings are programmed via parameter group 300-2*. It is advised to perform an automatic CT detection for all stand-alone filters via *300-29 Start Auto CT Detection*. Filter supports all standard CTs with 1A or 5A secondary rating.

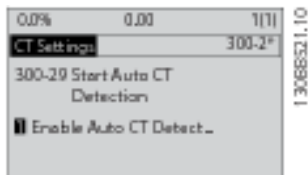

NOTE!

The automatic CT detection is only possible with CT installed on the source side

CTs should have an accuracy of 0.5% or better to ensure sufficient accuracy.

To test the set-up and ensure that the active filter is running correctly, follow these steps:

⚠ CAUTION

Incorrect current transformer connection, installation or configuration will lead to unintended and uncontrollable behavior of the filter.

1.	<i>300-26 CT Placement</i>
2.	<i>300-29 Start Auto CT Detection</i>

Follow these steps to ensure the correct installation of current transformers:

1. Locate the CT.
2. Note the position in the installation as well as the secondary and primary current levels.
3. Check that mechanical CT pin connection MK108 or MK101 is according to CT secondary rating.
4. Enter the CT location in *300-26 CT Placement*.
5. Enter the primary current from the plate data in this *300-20 CT Primary Rating*.

Performing an Auto CT:

The automatic current transformer detection will set the CT polarity, phase sequence and current ratio.

Stop the CT detection during operation:

Press the [off] key – the filter enters into alarm mode and display show that the Auto CT was terminated by the user.

Successful CT detection:

The display will show the found ratios, parameters and the phase sequence. Press [OK] to accept the found parameters. After CT detection, the filter is ready to start operation.

CT detection failed:

Danfoss CT auto detection support most standard CTs. The auto CT detection will not succeed if:

- CTs are not wired correctly
- CTs are installed on the load side
- Primary rate is not a standard size
- Secondary rate and CT placement are not configured
- CT current primary rate is greater than 10 times the filter current rate

A manual configuration is needed if the automatic CT detection fails to set the CTs. In that is the case, set the following parameters according to the CT plate data and installation:

1. 300-20 CT Primary Rating
2. 300-24 phase sequence
3. 300-25 CT polarity

The active filter allows different CT polarity of all three current transformers. That means that *300-25 CT Polarity* need to be set for all three CTs individually.

The current transducers are then successfully configured and the filter is ready for operation. To set-up the filter compensation mode and priority, please consult the chapter **How to program**.



5 How to Operate the Active Filter

5.1 Ways of Operation

The active filter can be operated in 2 ways:

1. Graphical Local Control Panel (GLCP)
2. RS-485 serial communication or USB, both for PC connection

5.1.1 How to Operate Graphical LCP (GLCP)

The GLCP is divided into four functional groups:

1. Graphical display with Status lines.
2. Menu keys and LEDs - selecting mode, changing parameters and switching between display functions.
3. Navigation keys and LEDs (LEDs).
4. Operation keys and LEDs.

Graphical display:

The LCD display is back lit with a total of 6 alpha-numeric lines. All data is displayed on the LCP which can show up to five operating variables while in [Status] mode.

Display lines:

- a. **Status line:** Status messages displaying icons and graphics.
- b. **Line 1-2:** Operator data lines displaying data and variables defined or chosen by the user. By pressing the [Status] key, up to one extra line can be added.
- c. **Status line:** Status messages displaying text.

The display is divided into 3 sections:

Top section (a)

shows the status when in status mode, or up to two variables when not in status mode and in the event of an alarm/warning.

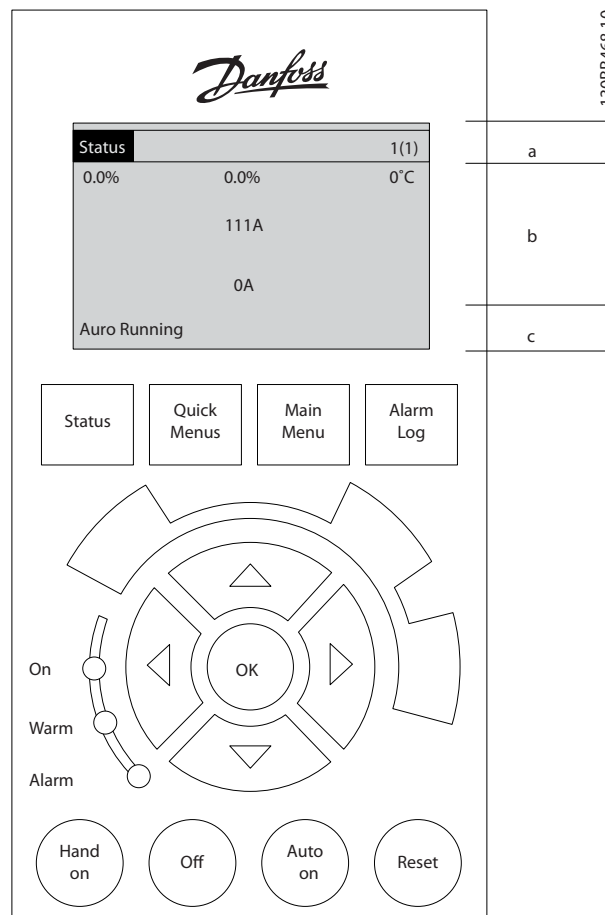

The number of the Active Set-up (selected as the Active Set-up in 0-10 Active Set-up) is shown. When programming in another set-up than the Active Set-up, the number of the set-up being programmed appears to the right in brackets.

Middle section (b)

shows up to 5 variables with related unit, regardless of status. In the event of an alarm/warning, the warning is shown instead of the variables.

It is possible to toggle between three status read-out displays by pressing the [Status] key.

Operating variables with different formatting are shown in each status screen - see below.

Several values or measurements can be linked to each of the displayed operating variables. The values/measurements to be displayed can be defined via parameters 0-20 Display Line 1.1 Small to 0-24 Display Line 3 Large, which can be accessed via [QUICK MENU], "Q3

Function Set-ups", "Q3-1 General Settings", "Q3-11 Display Settings".

Each value/measurement readout parameter selected in *0-20 Display Line 1.1 Small* to *0-24 Display Line 3 Large* has its own scale and number of digits after a possible decimal point. Larger numeric values are displayed with few digits after the decimal point.

Ex.: Current readout 5.25 A; 15.2 A 105 A.

Status display I

This readout state is standard after start-up or initialization. Use [INFO] to obtain information about the value/measurement linked to the displayed operating variables (1.1, 1.2, 1.3, 2 and 3).

See the operating variables shown in the display in this illustration. 1.1, 1.2 and 1.3 are shown in small size; 2 and 3 are shown in medium size.

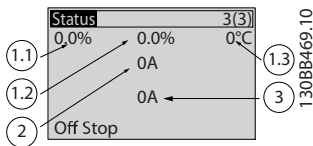

Status display II

See the operating variables (1.1, 1.2, 1.3 and 2) shown in the display in this illustration.

In this example, the small readouts are: Power Factor in the upper left corner (position 1.1). THiD of Current in the middle top (position 1.2), The line power current is displayed in the upper right corner (1.3). Large readouts are the Output current (position 2), and, lastly, underneath the line power frequency is the reactive current at position 3.

1.1, 1.2 and 1.3 are shown in small size; 2 is shown in large size.

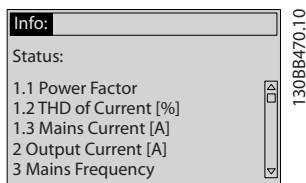

Bottom section

always shows the state of the unit in status mode.

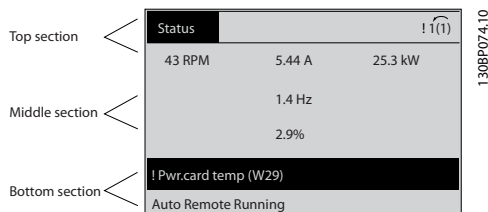

Display contrast adjustment

Press [status] and [▲] for darker display

Press [status] and [▼] for brighter display

LEDs:

If certain threshold values are exceeded, the alarm and/or warning LED lights up. A status and alarm text appear on the control panel.

The On LED is activated when the unit receives power from AC line voltage, a DC bus terminal or an external 24 V supply. At the same time, the back light is on.

- Green LED/On: Control section is working.
- Yellow LED/Warn.: Indicates a warning.
- Flashing Red LED/Alarm: Indicates an alarm.



LCPkeys

Menu keys

The menu keys are divided into functions. The keys below the display and LEDs are used for parameter set-up, including choice of display indication during normal operation.



[Status]

Indicates the status of the filter. Use the [Status] key to toggle single or double read-out mode - 5 line readouts, 4 line readouts.

Use [Status] for selecting the mode of display or for changing back to display mode from either the quick menu mode, the main menu mode or alarm mode.

[Quick Menu]

Allows quick set-up of the unit. **The most common functions can be programmed here.**

The [Quick Menu] consists of:

- Q1: My Personal Menu
- Q2: Quick set-up
- Q5: Changes Made
- Q6: Loggings

The Quick Menu parameters can be accessed immediately unless a password has been created via *0-60 Main Menu Password*, *0-61 Access to Main Menu w/o Password*, *0-65 Quick Menu Password* or *0-66 Access to Quick Menu w/o Password*.

It is possible to switch directly between Quick Menu mode and Main Menu mode.

[Main Menu]

is used for programming all parameters. The Main Menu parameters can be accessed immediately unless a password has been created via 0-60 Main Menu Password, 0-61 Access to Main Menu w/o Password, 0-65 Quick Menu Password or 0-66 Access to Quick Menu w/o Password.

It is possible to switch directly between Main Menu mode and Quick Menu mode. Parameter shortcut can be carried out by pressing down the [Main Menu] key for 3 seconds. The parameter shortcut allows direct access to any parameter.

[Alarm Log]

displays an alarm list of the five latest alarms (numbered A1-A5). To obtain additional details about an alarm, use the arrow keys to navigate to the alarm number and press [OK]. Information is displayed about the condition of the unit before it enters alarm mode.

[Back]

reverts to the previous step or layer in the navigation structure.

[Cancel]

the last change or command will be canceled as long as the display has not been changed.

[Info]

displays information about a command, parameter or function in any display window. [Info] provides detailed information when needed. Exit Info mode by pressing either [Info], [Back] or [Cancel].



Navigation keys

The four navigation arrows are used to navigate between the different choices available in [Quick Menu], [Main Menu] and [Alarm Log]. Use the keys to move the cursor.

[OK]

is used for choosing a parameter marked by the cursor and for enabling the change of a parameter.

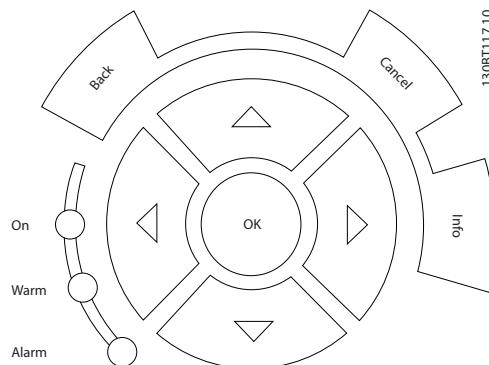

Operation keys

for local control are found at the bottom of the control panel.

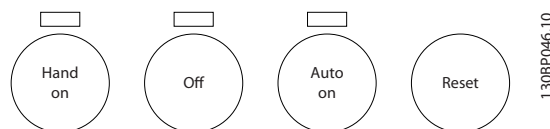

[Hand on]

enables control of the filter via the LCP. The key can be Enabled [1] or Disabled [0] via 0-40 [Hand on] Key on LCP

The following control signals will still be active when [Hand on] is activated:

- [Hand on] - [Off] - [Auto on]
- Reset
- Stop command from serial communication

NOTE!

External stop signals activated by means of control signals or a serial bus will override a "start" command via the LCP.

[Off]

stops the unit. The key can be Enabled [1] or Disabled [0] via 0-41 [Off] Key on LCP. If no external stop function is selected and the [Off] key is inactive, the unit can only be stopped by disconnecting the line power supply.

[Auto on]

enables the unit to be controlled via the control terminals and/or serial communication. When a start signal is applied on the control terminals and/or the bus, the unit will start. The key can be Enabled [1] or Disabled [0] via 0-42 [Auto on] Key on LCP.

NOTE!

An active HAND-OFF-AUTO signal via the digital inputs has higher priority than the control keys [Hand on] – [Auto on].

[Reset]

is used for resetting the filter after an alarm (trip). The key can be *Enabled* [1] or *Disabled* [0] via 0-43 [Reset] Key on LCP.

The parameter shortcut

can be carried out by holding down the [Main Menu] key for 3 seconds. The parameter shortcut allows direct access to any parameter.

5

5.1.2 Changing Data

The procedure for changing data is the same whether you select a parameter in the quick menu or the main menu mode. Press [OK] to change the selected parameter. The procedure for changing data depends on whether the selected parameter represents a numerical data value or a text value.

5.1.3 Changing a Text Value

If the selected parameter is a text value, it can be changed by using the up/down navigation keys. The up key increases the value, and the down key decreases the value. Place the cursor on the value to be saved and press [OK].

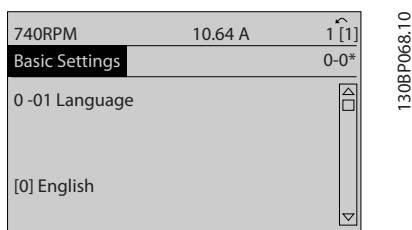

Figure 5.1 Display example.

5.1.4 Changing a Group of Numeric Data Values

If the chosen parameter represents a numeric data value, change the chosen data value by means of the [◀] and [▶] navigation keys as well as the up/down [▲] [▼] navigation keys. Use the [◀] and [▶] navigation keys to move the cursor horizontally.

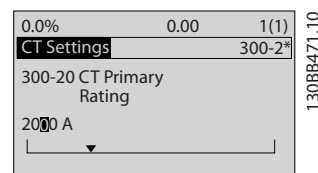

Figure 5.2 Display example.

Use the up/down navigation keys to change the data value. The up key increases the data value, while the down key reduces it. Place the cursor on the value to be saved and press [OK].

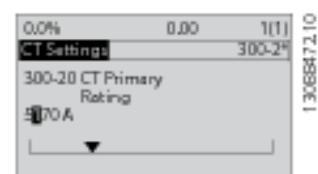

Figure 5.3 Display example.

5.1.5 Read-out and Programming of Indexed Parameters

Parameters are indexed when placed in a rolling stack. 15-30 Alarm Log: Error Code to 15-32 Alarm Log: Time contain a fault log which can be read out. Choose a parameter, press [OK], and use the up/down navigation keys to scroll through the value log.

Use 3-10 Preset Reference as another example:

Choose the parameter, press [OK], and use the up/down navigation keys to scroll through the indexed values. To change the parameter value, select the indexed value and press [OK]. Change the value by using the up/down keys. Press [OK] to accept the new setting. Press [Cancel] to abort. Press [Back] to leave the parameter.

5.1.6 Tips and Tricks

- The AAF hold standard parameters to ensure lowest possible need of changes. For the majority of applications, the Quick Menu, Quick Set-up provides the simplest and quickest access to all the typical parameters required.
- Performing an Auto CT for all stand-alone filters to set correct current sensor set-up. Auto CT set-up is only possible if CTs are installed at Point of Common Coupling PCC (towards the transformer). CT of LHD is preset from factory.

- Under [Quick Menu] and [Changes Made], any parameter that has been changed from factory settings is displayed.
- Press and hold the [Main Menu] key for 3 seconds to access any parameter
- For service purposes, it is recommended to copy all of the parameters to the LCP; see *0-50 LCP Copy* for further information.

5.1.7 Quick Transfer of Parameter Settings between Multiple Active Filters

Once the set-up of a filter is complete, we recommend that you store the data in the LCP or on a PC via MCT 10 Set-up Software.

Data storage in LCP:

1. Go to *0-50 LCP Copy*
2. Press the [OK] key
3. Select "All to LCP"
4. Press the [OK] key

All parameter settings are now stored in the LCP indicated by the progress bar. When 100% is reached, press [OK].

You can now connect the LCP to another filter and copy the parameter settings to this unit as well.

Data transfer from LCP to filter:

1. Go to *0-50 LCP Copy*
2. Press the [OK] key
3. Select "All from LCP"
4. Press the [OK] key

The parameter settings stored in the LCP are now transferred to the filter indicated by the progress bar. When 100% is reached, press [OK].

5.1.8 Initialization to Default Settings

There are two ways to initialize the filter to default: recommended initialization and manual initialization. Please be aware that they have different impact according to the description below.

Recommended initialization (via *14-22 Operation Mode*)

1. Select *14-22 Operation Mode*
2. Press [OK]
3. Select "Initialization" (for NLCP select "2")
4. Press [OK]

5. Disconnect the power from the unit and wait for the display to turn off.
6. Reconnect power and the unit is reset. Note that first start-up takes a few more seconds
7. Press [Reset]

<i>14-22 Operation Mode</i> initializes all except:
<i>14-50 RFI 1</i>
<i>8-30 Protocol</i>
<i>8-31 Address</i>
<i>8-32 Baud Rate</i>
<i>8-35 Minimum Response Delay</i>
<i>8-36 Max Response Delay</i>
<i>8-37 Maximum Inter-Char Delay</i>
<i>15-00 Operating Hours to 15-05 Over Volts</i>
<i>15-20 Historic Log: Event to 15-22 Historic Log: Time</i>
<i>15-30 Alarm Log: Error Code to 15-32 Alarm Log: Time</i>

NOTE!

Parameters selected in *0-25 My Personal Menu* will remain present with the default factory setting.

Manual initialization

NOTE!

When carrying out manual initialization, serial communication and fault log settings are reset.

1. Disconnect from the line power and wait until the display turns off.
- 2a. Press [Status] - [Main Menu] - [OK] at the same time while powering up for LCP
- 2b. Press [Menu] while powering up for LCP 101, Numerical Display
3. Release the keys after 5 secs
4. The active filter is now programmed according to default settings

This parameter initializes all except:
<i>15-00 Operating Hours</i>
<i>15-03 Power-ups</i>
<i>15-04 Over Temps</i>
<i>15-05 Over Volts</i>

5.1.9 RS-485 Bus Connection

The filter can be connected to a controller (or master) together with other loads using the RS-485 standard interface. Terminal 68 is connected to the P signal (TX+, RX+), while terminal 69 is connected to the N signal (TX-,RX-).

5

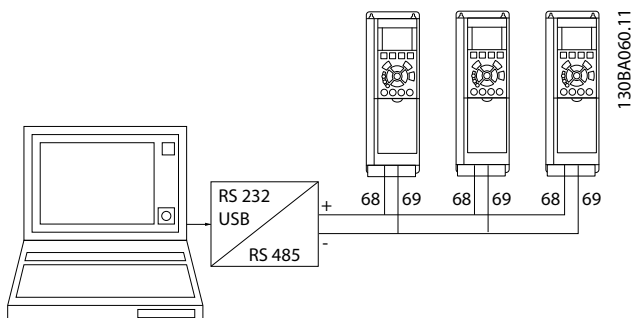

Figure 5.4 Connection example.

In order to avoid potential equalizing currents in the screen, earth the cable screen via terminal 61, which is connected to the frame via an RC-link.

Bus termination

The RS-485 bus must be terminated by a resistor network at both ends. If the unit is the first or the last device in the RS-485 loop, set the switch S801 on the control card for ON..

5.1.10 How to Connect a PC to the Active Filter

To control or program the filter from a PC, install the PC-based Configuration Tool MCT 10 Set-up Software. The PC is connected via a standard (host/device) USB cable to both devices, or via the RS-485 interface

NOTE!

The USB connection is galvanically isolated from the supply voltage (PELV) and other high-voltage terminals. The USB connection is connected to protection ground on the active filter. Use only an isolated laptop as PC connection to the USB connector on the active filter.

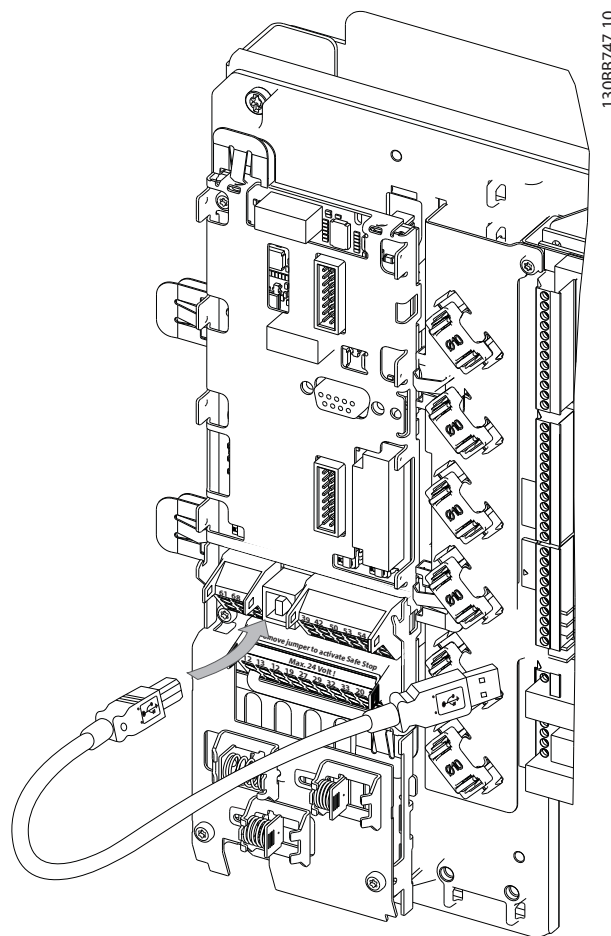

Figure 5.5 For control cable connections, see section on Control Terminals.

5.1.11 PC Software Tools

PC-based Configuration Tool MCT 10 Set-up Software

The active filter is equipped with one serial communication ports. Danfoss provides a PC tool for communication between PC and filter, PC-based Configuration Tool MCT 10 Set-up Software. Please consult the MCT 10 Set-up Software software help menu for further information.

MCT 10 Set-up Software

MCT 10 Set-up Software has been designed as an easy to use interactive tool for setting parameters in our active filters. The software can be downloaded from the Danfoss internet site <http://www.Danfoss.com/BusinessAreas/Drives-Solutions/SoftwareDownload/DDPC+Software+Program.htm>.

The MCT 10 Set-up Software will be useful for:

- Planning a communication network off-line. MCT 10 Set-up Software contains a complete active filter database
- Commissioning active filters on line
- Saving settings for all active filters
- Replacing an active filter in a network
- Simple and accurate documentation of active filter settings after commissioning.
- Expanding an existing network
- Future developed active filters will be supported

Save filter settings:

1. Connect a PC to the unit via USB com port. (NOTE: Use a PC, which is isolated from the line power, in conjunction with the USB port. Failure to do so may damage equipment.)
2. Open MCT 10 Set-up Software
3. Choose "Read from drive"
4. Choose "Save as"

All parameters are now stored on the PC.

Load filter settings:

1. Connect a PC to the unit via the USB com port.
2. Open MCT 10 Set-up Software
3. Choose "Open" – stored files will be shown
4. Open the appropriate file
5. Choose "Write to drive"

All parameter settings are now transferred to the filter.

A separate manual for MCT 10 Set-up Software is available: *MG.10.Rx.yy.*

The MCT 10 Set-up Software modules

The following modules are included in the software package:

	<p>MCT 10 Set-up Software Setting parameters Copy to and from unit Documentation and print out of parameter settings incl. diagrams</p>
	<p>Ext. user interface Preventive Maintenance Schedule Clock settings Timed Action Programming Smart Logic Controller Set-up</p>

Ordering number:

Please order the CD containing MCT 10 Set-up Software using code number 130B1000.

MCT 10 Set-up Software can also be downloaded from the Danfoss Internet: *WWW.DANFOSS.COM*, Business Area: *Motion Controls.*

6 How to Program

6.1.1 Parameter Set-up

The factory settings for the active filter are chosen for optimal operation for most applications with a minimum of programming needed. The filter is set in overall harmonic compensation mode with harmonic current priority. Selection of readouts and what information to be displayed on the LCP status lines can be made to fit individual preferences. The filter will only in a few cases have to be tuned specially for the given grid and load conditions.

The following steps are often sufficient, to set up the filter and get proper operation:

- Program the external CTs:
 - Check that the CT location is correct in *300-26 CT Placement*
 - Activate the Auto CT Detection in *300-29 Start Auto CT Detection*
 - Confirm the found CT ratio, polarity and sequence.
- Make sure that the filter is in auto mode (press [Auto On] on the LCP)

Parameter descriptions and selections are displayed on the graphic (LCP) display area. (See 5 *How to Operate the Active Filter* for details.) Access the parameters by pressing the [Quick Menu] or [Main Menu] key on the control panel. The quick menu is used primarily for commissioning the unit at start-up by providing those parameters necessary to start operation. The main menu provides access to all the parameters for detailed application programming. All digital input/output terminals are multifunctional. All terminals have factory default functions suitable for most applications but if other special functions are required, they must be programmed in parameter group 5-**.

6.1.2 Quick Menu Mode

The GLCP provides access to all parameters listed under the Quick Menus. To set parameters using the [Quick Menu] button:

Pressing [Quick Menu] the list indicates the different areas contained in the quick menu.

Efficient parameter set-up for most applications

The parameters can easily be set up for most the applications only by using the [Quick Menu].

The best way to set parameters using the [Quick Menu] is by following the steps below:

1. Press [Quick set-up] for selecting language, compensation mode, CT-set-up, etc.
2. Press [My personal Menu] to set up the LCP readout parameters. If preset display is acceptable, this operation can be left out.

It is recommended to do the set-up in the order listed.

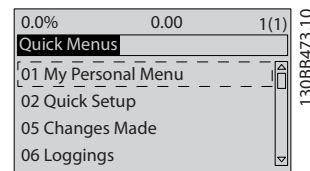

Figure 6.1 Quick Menu view.

If *No Operation* is selected in terminal 27, no connection to +24 V on terminal 27 is necessary to enable start. If *Coast Inverse* is selected in Terminal 27, a connection to +24V is necessary to enable start.

6.1.3 Q1 My Personal Menu

Parameters defined by the user can be stored in Q1 My Personal Menu. Select My Personal Menu to display only the parameters, which have been pre-selected and programmed as personal parameters. A large scale active filter user may have pre-programmed important set-up values in the My Personal Menu to make on site commissioning / fine-tuning simpler. These parameters are selected in *0-25 My Personal Menu*. Up to 20 different parameters can be defined in this menu.

Q1 My Personal Menu	
Parameter number and Name	Factory default
0-01 Language	English
0-20 Display Line 1.1 Small	Power Factor
0-21 Display Line 1.2 Small	THD of current
0-22 Display Line 1.3 Small	Line power current
0-23 Display Line 2 Large	Output current (corrected)
0-24 Display Line 3 Large	Line power frequency
15-51 Frequency Converter Serial Number	

6.1.4 Q2 Quick Set-up

The parameters in Q2 Quick set-up are the basic parameters which are always needed to set up the active filter to operation.

Q2 Quick Set-up	
Parameter number and Name	Factory default
0-01 Language	English
300-22 CT Nominal Voltage	Same as AF
300-29 Start Auto CT Detection	Off
300-01 Compensation Priority	Harmonics
300-00 Harmonic Cancellation Mode	Overall

NOTE!

It is necessary to set the nominal voltage and CT Secondary rating, as well as change 300-26 CT Placement to PCC, before the Auto CT detection is started. Auto CT detection is only possible if CTs are located at the point of common coupling.

6.1.5 Q5 Changes Made

Q5 Changes Made can be used for fault finding.

Select Changes made to get information about:

- • the last ten changes. Use the up/down navigation keys to scroll between the last ten changed parameters.
- the changes made since default setting.

6.1.6 Q6 Loggings

Q6 Loggings can be used for fault finding. Select Loggings to get information about the display line readouts. The information is shown as graphs. Only display parameters selected in 0-20 Display Line 1.1 Small and 0-24 Display Line 3 Large can be viewed. It is possible to store up to 120 samples in the memory for later reference. Please notice that the parameters listed in the below table for Q6 only serve as examples as they will vary depending on the programming of the particular active filter.

Q6 Loggings	
0-20 Display Line 1.1 Small	Power Factor
0-21 Display Line 1.2 Small	THD of current
0-22 Display Line 1.3 Small	Line Power Current
0-23 Display Line 2 Large	Output Current
0-24 Display Line 3 Large	Line Power Frequency

6.1.7 Main Menu Mode

The LCP provide access to main menu mode. Select the Main Menu mode by pressing the [Main Menu] key. shows the resulting readout, which appears on the display of the GLCP.

Lines 2 through 5 on the display show a list of parameter groups which can be chosen by toggling the up and down buttons.

Each parameter has a name and number which remain the same regardless of the programming mode. In main menu mode, the parameters are divided into groups. The first digit of the parameter number (from the left) indicates the parameter group number. All parameters can be changed in the Main Menu. Option cards added to the unit enable additional parameters associated with the option device.

6.1.8 Parameter Selection

In main menu mode, the parameters are divided into groups. Select a parameter group with the navigation keys. The following parameter groups are accessible:

Group	Title	Function
0-**	Operation/Display	Parameters related to the fundamental functions of the filter, function of the LCP buttons and configuration of the LCP display.
5-**	Digital In/Out	Parameter group for configuring the digital inputs and outputs.
8-**	Communication and Options	Parameter group for configuring communications and options.
14-**	Special Functions	Parameter group for configuring special filter functions.
15-**	Unit Information	Parameter group containing filter information such as operating data, hardware configuration, and software versions.
16-**	Data Readouts	Parameter group for data readouts, e.g. actual references, voltages, control, alarm, warning and status words.
300-**	AF Settings	Parameter group for setting the active filter. Apart from par. 300-10, Active Filter Nominal Voltage, it is not recommended to change the settings of this parameter group.
301-**	AF Readouts	Parameter group for the filter readouts.

Table 6.1 Parameter groups

After selecting a parameter group, choose a parameter with the navigation keys. The middle section on the GLCP display shows the parameter number and name, as well as the selected parameter value.

6.2 Description of Parameters

6.2.1 Main Menu

The Main Menu includes all available parameters in the VLT® Active Filter. All parameters are grouped logically with a group name indicating the function of the parameter group. All parameters are listed by name and number in the following section. A quicker overview can be found in the Parameter Lists later in this manual.

6.3 0-** Operation/Display

Parameters related to the fundamental functions of the active filter, function of the LCP buttons and configuration of the LCP display.

6.3.1 0-0* Basic Settings

0-01 Language		
Option:	Function:	
		Defines the language to be used in the display. The filter can be delivered with four different language packages. English and German are included in all packages. English cannot be erased or manipulated.
[0] *	English	Part of Language packages 1 - 4
[1]	Deutsch	Part of Language packages 1 - 4
[2]	Francais	Part of Language package 1
[3]	Dansk	Part of Language package 1
[4]	Spanish	Part of Language package 1
[5]	Italiano	Part of Language package 1
	Svenska	Part of Language package 1
[7]	Nederlands	Part of Language package 1
[10]	Chinese	Part of Language package 2
	Suomi	Part of Language package 1
[22]	English US	Part of Language package 4
	Greek	Part of Language package 4
	Bras.port	Part of Language package 4
	Slovenian	Part of Language package 3
	Korean	Part of Language package 2
	Japanese	Part of Language package 2
	Turkish	Part of Language package 4

0-01 Language		
Option:	Function:	
	Trad.Chinese	Part of Language package 2
	Bulgarian	Part of Language package 3
	Srpski	Part of Language package 3
	Romanian	Part of Language package 3
	Magyar	Part of Language package 3
	Czech	Part of Language package 3
	Polski	Part of Language package 4
	Russian	Part of Language package 3
	Thai	Part of Language package 2
	Bahasa Indonesia	Part of Language package 2
[52]	Hrvatski	

6.3.2 0-04 Operating State at Power-up (Hand)

0-04 Operating State at Power-up (Hand)		
Option:	Function:	
		Selects the operating mode upon reconnection of the filter to AC line voltage after power down in hand (local) operation mode.
[0]	Resume	Restarts the filter maintaining the same start/stop settings (applied by [HAND ON/OFF]) as before the filter was powered down.
[1] *	Forced stop	Restarts the filter with a saved local reference, after AC line voltage reappears and after pressing [HAND ON].

6.3.3 0-1* Set-up Operations

Define and control the individual parameter set-ups. The filter has four parameter set-ups that can be programmed independently of each other. This makes the filter very flexible.

The active set-up (i.e., the set-up in which the filter is currently operating) can be selected in *0-10 Active Set-up* and is displayed in the LCP. Using Multi set-up, it is possible to switch between set-ups with the filter running or stopped, via digital input or serial communication commands. If it is necessary to change set-ups while running, ensure *0-12 This Set-up Linked to* is programmed as required. Using *0-11 Edit Set-up* it is possible to edit parameters within any of the set-ups while continuing the filter operation in its Active set-up which can be a different

set-up to that being edited. Using *0-51 Set-up Copy*, it is possible to copy parameter settings between the set-ups to enable quicker commissioning if similar parameter settings are required in different set-ups.

0-10 Active Set-up		
Option:	Function:	
		Select the set-up to control the filter functions.
[0]	Factory setup	Cannot be changed. It contains the Danfoss data set, and can be used as a data source when returning the other set-ups to a known state.
[1] *	Set-up 1	<i>Set-up 1</i> [1] to <i>Set-up 4</i> [4] are the four separate parameter set-ups within which all parameters can be programmed.
[2]	Set-up 2	
[3]	Set-up 3	
[4]	Set-up 4	
[9]	Multi Set-up	Remote selection of set-ups using digital inputs and the serial communication port. This set-up uses the settings from <i>0-12 This Set-up Linked to</i> . Stop the filter before making changes to open-loop and closed-loop functions

Use *0-51 Set-up Copy* to copy a set-up to one or all other set-ups. Stop the filter before switching between set-ups where parameters marked 'not changeable during operation' have different values. To avoid conflicting settings of the same parameter within two different set-ups, link the set-ups together using *0-12 This Set-up Linked to*. Parameters which are 'not changeable during operation' are marked FALSE in the parameter lists in the section *Parameter Lists*.

0-11 Edit Set-up		
Option:	Function:	
		Select the set-up to be edited (i.e., programmed) during operation: either the active set-up or one of the inactive set-ups.
[0]	Factory setup	Cannot be edited, but it is useful as a data source for returning the other set-ups to a known state.
[1] *	Set-up 1	<i>Set-up 1</i> [1] to <i>Set-up 4</i> [4] can be edited freely during operation, independently of the active set-up.
[2]	Set-up 2	
[3]	Set-up 3	
[4]	Set-up 4	
[9]	Active Set-up	Can also be edited during operation. Edit the chosen set-up from a range of sources: LCP, FC RS-485, FC USB or up to five Serial communication bus sites.

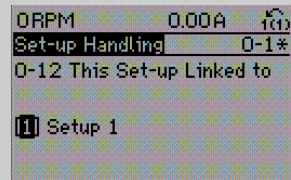
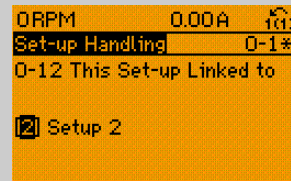
0-12 This Set-up Linked to		
Option:	Function:	
		To enable conflict-free changes from one set-up to another during operation, link set-ups containing parameters that are not changeable during operation. The link will ensure the proper synchronization of the 'not changeable during operation' parameter values when moving from one set-up to another during operation. 'Not changeable during operation' parameters can be identified by the label FALSE in the parameter lists in the section <i>Parameter Lists</i> .
		<i>0-12 This Set-up Linked to</i> is used by Multi set-up in <i>0-10 Active Set-up</i> . Multi set-up is used to move from one set-up to another during operation (e.g., while the filter is running). Example: Use Multi set-up to shift from Set-up 1 to Set-up 2 while the motor is running. Program in Set-up 1 first, then ensure that Set-up 1 and Set-up 2 are synchronized (or 'linked'). Synchronization can be performed in two ways:
		1. Change the edit set-up to <i>Set-up 2</i> [2] in <i>0-11 Edit Set-up</i> and set <i>0-12 This Set-up Linked to</i> to <i>Set-up 1</i> [1]. This will start the linking (synchronizing) process.
		
		OR
		2. While still in Set-up 1, copy Set-up 1 to Set-up 2. Then set <i>0-12 This Set-up Linked to</i> to <i>Set-up 2</i> [2]. This will start the linking process.
		
		After the link is complete, <i>0-13 Readout: Linked Set-ups</i> will read {1,2} to indicate that all 'not changeable during operation' parameters are now the same in Set-up 1 and Set-up 2. If there are changes to a "not changeable during operation" parameter, e.g., <i>1-30 Stator Resistance (Rs)</i> in Set-up 2, they will also be changed

0-12 This Set-up Linked to		
Option:	Function:	
		automatically in Set-up 1. A switch between Set-up 1 and Set-up 2 during operation is now possible.
[0] *	Not linked	
[1]	Set-up 1	
[2]	Set-up 2	
[3]	Set-up 3	
[4]	Set-up 4	

0-13 Readout: Linked Set-ups														
Array [5]														
Range:	Function:													
0* [0 - 255]	View a list of all the set-ups linked by means of 0-12 <i>This Set-up Linked to</i> . The parameter has one index for each parameter set-up. The parameter value displayed for each index represents which set-ups are linked to that parameter set-up.													
	<table border="1"> <thead> <tr> <th>Index</th> <th>LCP value</th> </tr> </thead> <tbody> <tr> <td>0</td> <td>{0}</td> </tr> <tr> <td>1</td> <td>{1,2}</td> </tr> <tr> <td>2</td> <td>{1,2}</td> </tr> <tr> <td>3</td> <td>{3}</td> </tr> <tr> <td>4</td> <td>{4}</td> </tr> </tbody> </table>	Index	LCP value	0	{0}	1	{1,2}	2	{1,2}	3	{3}	4	{4}	
Index	LCP value													
0	{0}													
1	{1,2}													
2	{1,2}													
3	{3}													
4	{4}													
<p>Table 6.3 Example: Set-up 1 and Set-up 2 are linked</p>														

0-14 Readout: Edit Set-ups / Channel		
Range:	Function:	
0* [-2147483648 - 2147483647]	View the setting of 0-11 <i>Edit Set-up</i> for each of the four different communication channels. When the number is displayed in hex, as it is in the LCP, each number represents one channel. Numbers 1-4 represent a set-up number; 'F' means factory setting; and 'A' means active set-up. The channels are, from right to left: LCP , FC-bus, USB, HPFB1-5. Example: The number AAAAAA21h means that the FC bus selected Set-up 2 in 0-11 <i>Edit Set-up</i> , the LCP selected Set-up 1 and all others used the active set-up.	

6.3.4 0-2* LCP Display

Define the variables displayed in the Graphical Local Control Panel.

NOTE!

Please refer to 0-37 *Display Text 1*, 0-38 *Display Text 2* and 0-39 *Display Text 3* for information on how to write display texts.

0-20 Display Line 1.1 Small		
Option:	Function:	
		Select a variable for display in line 1, left position.
[0]	None	No display value selected.
[1501]	Running Hours	
[1600]	Control Word	Present control word
[1603]	Status Word	Present status word.
[1630]	DC Link Voltage	Intermediate circuit voltage in the unit.
[1634]	Heatsink Temp.	Present heatsink temperature of the unit. The cut-out limit is 203°F ±9°F [95°C ± 5°C]; cutting back in occurs at 158°F ±9°F [70°C ± 5°C].
[1635]	Inverter Thermal	Percentage load of the inverters.
[1636]	Inv. Nom. Current	Nominal current of the unit.
[1637]	Inv. Max. Current	Maximum current of the unit.
[1639]	Control Card Temp.	Temperature of the control card.
[1660]	Digital Input	Signal states form the 6 digital terminals (18, 19, 27, 29, 32 and 33). There are 16 bits in total, but only six of them are used. Input 18 corresponds to the leftmost area of the used bits. Signal low = 0; Signal high = 1.
[1666]	Digital Output [bin]	Binary value of all digital outputs.
[1671]	Relay Output [bin]	
[1680]	Serial communication bus CTW 1	Control word (CTW) received from the bus master.
[1684]	Comm. Option STW	Extended Serial communication bus communication option status word.
[1685]	FC Port CTW 1	Control word (CTW) received from the bus master.
[1690]	Alarm Word	One or more alarms in a Hex code.
[1691]	Alarm Word 2	One or more alarms in a Hex code.

0-20 Display Line 1.1 Small		
Option:	Function:	
[1692]	Warning Word	One or more warnings in a Hex code.
[1693]	Warning Word 2	One or more warnings in a Hex code.
[1694]	Ext. Status Word	One or more status conditions in a Hex code.
[3430]	PCD 10 Read from MCO	
[30100]	Digital Inputs	
[30101]	Digital Outputs	
[30102]	Commanded Position	
[30103]	Slave Index Position	
[30104]	Curve Position	
[30107]	Synchronizing Error	
[30108]	Actual Master Velocity	
[30109]	Axis Status	
[30110]	MCO 302 Status	
[30120]	MCO 302 Control	
[30121]	MCO Alarm Word 1	
[30122]	MCO Alarm Word 2	
[30123]	Idle time	
[30124]	Paramdb requests in queue	
[30130]	tCon1 time	
[30131]	tCon2 time	
[30132]	Time Optimize Measure	
[30133]	HS Temp. (PC1)	
[30134]	HS Temp. (PC2)	
[30135]	HS Temp. (PC3)	

0-21 Display Line 1.2 Small		
Option:	Function:	
[0] *	None	Select a variable for display in line 1, middle position. The options are the same as listed for <i>0-20 Display Line 1.1 Small</i> .

0-22 Display Line 1.3 Small		
Option:	Function:	
[30120] *	Mains Current [A]	Select a variable for display in line 1, right position. The options are the same as listed for <i>0-20 Display Line 1.1 Small</i> .

0-23 Display Line 2 Large		
Option:	Function:	
[30100] *	Output Current [A]	Select a variable for display in line 2. The options are the same as listed for <i>0-20 Display Line 1.1 Small</i> .

0-24 Display Line 3 Large		
Select a variable for display in line 3.		
Option:	Function:	
[30121] *	Mains Frequency	The options are the same as those listed in <i>0-20 Display Line 1.1 Small</i> .

0-25 My Personal Menu		
Range:	Function:	
Application dependent*	[0 - 9999]	Define up to 50 parameters to appear in the Q1 Personal Menu, accessible via the [Quick Menu] key on the LCP. The parameters will be displayed in the Q1 Personal menu in the order they are programmed into this array parameter. Delete parameters by setting the value to '0000'. For example, this can be used to provide quick, simple access to just one or up to 50 parameters which require changing on a regular basis (e.g., for plant maintenance reasons) or by an OEM to enable simple commissioning of their equipment.

6.3.5 0-4* LCP Keypad

Enable, disable and password protect individual keys on the LCP.

6.3.6 0-40 [Hand on] Key on LCP

0-40 [Hand on] Key on LCP		
Option:	Function:	
[0]	Disabled	No effect when [Hand on] is pressed. Select [0] Disabled to avoid accidental start of the Adjustable frequency drive in <i>Hand on</i> mode.
[1] *	Enabled	
[2]	Password	Avoids unauthorized stop. If <i>0-41 [Off] Key on LCP</i> is included in the Quick Menu, then define the password in <i>0-65 Quick Menu Password</i> .

0-41 [Off] Key on LCP		
Option:	Function:	
[0] *	Disabled	Avoids accidental stop of the unit.
[1] *	Enabled	
[2]	Password	Avoids unauthorized stop. If <i>0-41 [Off] Key on LCP</i> is included in the Quick Menu, then define the password in <i>0-65 Quick Menu Password</i> .

0-42 [Auto on] Key on LCP		
Option:	Function:	
[0] *	Disabled	Avoid accidental start of the unit in auto mode.
[1] *	Enabled	
[2]	Password	Avoids unauthorized start in auto mode. If 0-42 [Auto on] Key on LCP is included in the Quick Menu, then define the password in 0-65 Quick Menu Password.

0-43 [Reset] Key on LCP		
Option:	Function:	
[0] *	Disabled	No effect when [Reset] is pressed. Avoids accidental alarm reset.
[1] *	Enabled	
[2]	Password	Avoids unauthorized resetting. If 0-43 [Reset] Key on LCP is included in the Quick Menu, then define the password in 0-65 Quick Menu Password.
[7]	Enabled without OFF	Resets the Adjustable frequency drive without setting it in Off mode.
[8]	Password without OFF	Resets the Adjustable frequency drive without setting it in Off mode. A password is required when pressing [Reset] (see [2]).

6.3.7 0-5* Copy/Save

Copy parameter settings between set-ups and to/from the LCP.

0-50 LCP Copy		
Option:	Function:	
[0] *	No copy	
[1]	All to LCP	Copies all parameters in all set-ups from the filter memory to the LCP memory.
[2]	All from LCP	Copies all parameters in all set-ups from the LCP memory to the filter memory.
[3]	Size indep. from LCP	Copy only the parameters that are independent of the motor size. The latter selection can be used to program several filters with the same function without disturbing motor data.
[4]	File from MCO to LCP	
[5]	File from LCP to MCO	
[6]	Data from DYN to LCP	

0-50 LCP Copy		
Option:	Function:	
[7]	Data from LCP to DYN	

This parameter cannot be adjusted while the motor is running.

0-51 Set-up Copy		
Option:	Function:	
[0] *	No copy	No function
[1]	Copy to set-up 1	Copies all parameters in the present Programming Set-up (defined in 0-11 Programming Set-up) to Set-up 1.
[2]	Copy to set-up 2	Copies all parameters in the present Programming Set-up (defined in 0-11 Programming Set-up) to Set-up 2.
[3]	Copy to set-up 3	Copies all parameters in the present Programming Set-up (defined in 0-11 Programming Set-up) to Set-up 3.
[4]	Copy to set-up 4	Copies all parameters in the present Programming Set-up (defined in 0-11 Programming Set-up) to Set-up 4.
[9]	Copy to all	Copies the parameters in the present set-up over to each of the set-ups 1 to 4.

6.3.8 0-6* Password

0-60 Main Menu Password		
Range:	Function:	
100*	[0 - 999]	Define the password for access to the main menu via the [Main Menu] key. If 0-61 Access to Main Menu w/o Password is set to Full access [0], this parameter will be ignored.

0-61 Access to Main Menu w/o Password		
Option:	Function:	
[0] *	Full access	Disables password defined in <i>0-60 Main Menu Password</i> .
[1]	LCP: Read only	Prevent unauthorized editing of main menu parameters.
[2]	LCP: No access	Prevent unauthorized viewing and editing of main menu parameters.
[3]	Bus: Read only	Read-only functions for parameters on Serial communication bus and/or FC standard bus.
[4]	Bus: No access	No access to parameters is allowed via Serial communication bus and/or FC standard bus.
[5]	All: Read only	Read-only function for parameters on LCP, Serial communication bus or FC standard bus.
[6]	All: No access	No access from LCP, Serial communication bus or FC standard bus is allowed.

0-66 Access to Quick Menu w/o Password		
Option:	Function:	
[4]	Bus: No access	No access to quick menu parameters is allowed via Serial communication bus and/or FC standard bus.
[5]	All: Read only	read only function for quick menu parameters on LCP, Serial communication bus or FC standard bus.
[6]	All: No access	No access from LCP, Serial communication bus or FC standard bus is allowed.

If *0-61 Access to Main Menu w/o Password* is set to *Full access* [0], then this parameter will be ignored.

If *Full access* [0] is selected then *0-60 Main Menu Password*, *0-65 Personal Menu Password* and *0-66 Access to Personal Menu w/o Password* will be ignored.

NOTE!

More complex password protection is available for OEMs upon request.

0-65 Quick Menu Password		
Range:	Function:	
200*	[-9999 - 9999]	Define the password for access to the quick menu via the [Quick Menu] key. If <i>0-66 Access to Quick Menu w/o Password</i> is set to <i>Full access</i> [0], this parameter will be ignored.

0-66 Access to Quick Menu w/o Password		
Option:	Function:	
[0] *	Full access	Disables the password defined in <i>0-65 Quick Menu Password</i> .
[1]	LCP: Read only	Prevents unauthorized editing of quick menu parameters.
[2]	LCP: No access	Prevents unauthorized viewing and editing of quick menu parameters.
[3]	Bus: Read only	Read only functions for quick menu parameters on Serial communication bus and/ or FC standard bus.

6.4 5-** Digital I/O Mode

6.4.1 5-0* Digital I/O Mode

Parameters for configuring the input and output using NPN and PNP.

These parameters cannot be adjusted while motor is running.

5-00 Digital I/O Mode		
Option:	Function:	
		Digital inputs and programmed digital outputs are pre-programmable for operation either in PNP or NPN systems.
[0] *	PNP	Action on positive directional pulses (‡). PNP systems are pulled down to GND.
[1]	NPN	Action on negative directional pulses (‡). NPN systems are pulled up to + 24 V, internally in the filter.

NOTE!

Once this parameter has been changed, it must be activated by performing a power cycle.

This parameter cannot be adjusted while the motor is running.

5-01 Terminal 27 Mode		
Option:	Function:	
[0] *	Input	Defines terminal 27 as a digital input.
[1]	Output	Defines terminal 27 as a digital output.

5-02 Terminal 29 Mode		
Option:	Function:	
[0] *	Input	Defines terminal 29 as a digital input.
[1]	Output	Defines terminal 29 as a digital output.

6.4.2 5-1* Digital Inputs

Parameters for configuring the input functions for the input terminals.

The digital inputs are used for selecting various functions in the filter. All digital inputs can be set to the following functions:

Digital input function	Select	Terminal
No operation	[0]	All *term 32, 33
Reset	[1]	All
Stop inverse	[6]	All
Start	[8]	All *term 18
Latched start	[9]	All
Set-up select bit 0	[23]	All
Set-up select bit 1	[24]	All
Pulse input Time Based	[32]	29, 33
Follower AF # 1 Run Feedback	[99]	All
Follower AF # 2 Run Feedback	[100]	All
Sleep	[101]	T18, T19, T27, T29

Functions dedicated to only one digital input are stated in the associated parameter.

5-10 Terminal 18 Digital Input		
Option:	Function:	
[0]	No operation	No reaction to signals transmitted to the terminal.
[1]	Reset	Resets filter after a TRIP/ALARM. Not all alarms can be reset.
[6]	Stop inverse	Stop Inverted function. Generates a stop function when the selected terminal goes from logical level '1' to '0'.
[8] *	Start	(Default Digital input 18): Select start for a start/stop command. Logic '1' = start, logic '0' = stop.
[9]	Latched Start	The filter starts, if a pulse is applied for min. 2 ms. The filter stops when Stop inverse is activated.
[23]	Set-up select bit 0	Select Set-up select bit 0 or Select Set-up select bit 1 to select one of the four set-ups. Set 0-10 Active Set-up to Multi Set-up.
[24]	Set-up select bit 1	(Default Digital input 32): Same as Set-up select bit 0 [23].
[32]	Master cmd pulse in	Time-based pulse input measures the duration between flanks. This gives a higher resolution at lower frequencies, but is not as precise at higher frequencies. This principle has a cut-off frequency which makes it unsuited for encoders with very low resolutions (e.g., 30 ppr) at low speeds.
[99]	Follower AF #1 Run Feedback	Do not program this setting. It is done automatically for paralleling. See 300-40 Master Follower Selection and 300-41 Follower ID for more information about paralleling.

5-10 Terminal 18 Digital Input		
Option:	Function:	
[100]	Follower AF #2 Run Feedback	Do not program this setting. It is done automatically for paralleling. See 300-40 Master Follower Selection and 300-41 Follower ID for more information about paralleling.
[101]	Sleep	The filter goes into sleep mode at light duty to save energy.

5-11 Terminal 19 Digital Input		
Option:	Function:	
[0] *	No Operation	Functions are described under 5-1* Digital Inputs

5-12 Terminal 27 Digital Input		
Option:	Function:	
[0] *	No Operation	Functions are described under 5-1* Digital Inputs

5-13 Terminal 29 Digital Input		
Option:	Function:	
[0] *	No Operation	Functions are described under 5-1* Digital Inputs

5-14 Terminal 32 Digital Input		
Option:	Function:	
[90] *	AC Contactor	Functions are described under 5-1* Digital Inputs

5-15 Terminal 33 Digital Input		
Option:	Function:	
[91] *	DC Contactor	Functions are described under 5-1* Digital Inputs

5-16 Terminal X30/2 Digital Input		
Option:	Function:	
[0] *	No operation	Functions are described under 5-1* Digital Inputs

5-17 Terminal X30/3 Digital Input		
Option:	Function:	
[0] *	No operation	Functions are described under 5-1* Digital Inputs

5-18 Terminal X30/4 Digital Input		
Option:	Function:	
[0] *	No operation	Functions are described under 5-1* Digital Inputs

5-19 Terminal 37 Safe Stop		
Option:	Function:	
[1] *	Safe Stop Alarm	Coasts unit when safe stop is activated. Manual reset from LCP, digital input or Serial communication bus.
[3]	Safe Stop Warning	Coasts unit when safe stop is activated (T-37 off). When safe stop circuit is reestablished, the unit will continue without manual reset.
[4]	PTC 1 Alarm	Coasts unit when safe stop is activated. Manual reset from LCP, digital input or Serial communication bus. Choice 4 is only available when the MCB 112 PTC thermistor card is connected.
[5]	PTC 1 Warning	Coasts unit when safe stop is activated (T-37 off). When safe stop circuit is reestablished, the unit will continue without manual reset, unless a digital input set to PTC Card 1 [80] is still enabled. Choice 5 is only available when the MCB 112 PTC thermistor card is connected.
[6]	PTC 1 & Relay A	This choice is used when the PTC option is gated together with a stop button through a safety relay to T-37. Coasts unit when safe stop is activated. Manual reset from LCP, digital input or Serial communication bus. Choice 6 is only available when the MCB 112 PTC thermistor card is connected.
[7]	PTC 1 & Relay W	This choice is used when the PTC option is gated together with a stop button through a safety relay to T-37. Coasts unit when safe stop is activated (T-37 off). When safe stop circuit is reestablished, the unit will continue without manual reset, unless a digital input set to PTC Card 1 [80] is (still) enabled. Choice 7 is only available when the MCB 112 PTC thermistor card is connected.
[8]	PTC 1 & Relay A/W	This choice makes it possible to use a combination of alarm and warning. Choice 8 is only available when the MCB 112 PTC thermistor card is connected.
[9]	PTC 1 & Relay W/A	This choice makes it possible to use a combination of alarm and warning. Choice 9 is only available when the MCB 112 PTC thermistor card is connected.

Choices 4–9 are only available when the MCB 112 PTC thermistor card is connected.

Overview of functions, alarms and warnings

Function	No.	PTC	Relay
No Function	[0]	-	-
Safe Stop Alarm	[1]*	-	Safe Stop [A68]
Safe Stop Warning	[3]	-	Safe Stop [W68]
PTC 1 Alarm	[4]	PTC 1 Safe Stop [A71]	-
PTC 1 Warning	[5]	PTC 1 Safe Stop [W71]	-
PTC 1 & Relay A	[6]	PTC 1 Safe Stop [A71]	Safe Stop [A68]
PTC 1 & Relay W	[7]	PTC 1 Safe Stop [W71]	Safe Stop [W68]
PTC 1 & Relay A/W	[8]	PTC 1 Safe Stop [A71]	Safe Stop [W68]
PTC 1 & Relay W/A	[9]	PTC 1 Safe Stop [W71]	Safe Stop [A68]

W means warning, and A means alarm. For further information, see Alarms and Warnings in section Troubleshooting in the Design Guide or the Instruction Manual.

A dangerous failure related to the safe stop will give alarm: Dangerous Failure [A72].

Please refer to the section Description of Alarm Word, Warning Word and extended Status Word in the chapter Troubleshooting.

6.4.3 5-3* Digital Outputs

Parameters for configuring the output functions for the output terminals. The 2 solid-state digital outputs are common for terminals 27 and 29. Set the I/O function for terminal 27 in 5-01 Terminal 27 Mode, and set the I/O function for terminal 29 in 5-02 Terminal 29 Mode. These parameters cannot be adjusted while the unit is running.

5-30 Terminal 27 Digital Output		
Option:	Function:	
[0]	No operation	Default for all digital outputs and relay outputs
[1]	Control ready	The control card is ready. For example, Feedback from a Adjustable frequency drive where the control is supplied by an external 24 V (MCB 107) and the main power to Adjustable frequency drive is not detected.
[2]	Unit ready	The unit is ready for operation and applies a supply signal on the control board.

5-30 Terminal 27 Digital Output		
Option:	Function:	
[4]	Enable / no warning	Ready for operation. No start or stop command is been given (start/disable). No warnings are active.
[5]	Running	Motor is running and shaft torque is present.
[9]	Alarm	An alarm activates the output. There are no warnings.
[10]	Alarm or warning	An alarm or a warning activates the output.
[12]	Current limit	The motor current is outside the range set in 4-18 Current Limit.
[21]	Thermal warning	The thermal warning turns on when the temperature exceeds the limit in the motor, the unit, the brake resistor or the thermistor.
[22]	Ready,no thermal W	unit is ready for operation and there is no overtemperature warning.
[24]	Ready, voltage OK	unit is ready for operation and the AC line voltage is within the specified voltage range (see General Specifications section in the Design Guide).
[26]	Bus OK	Active communication (no timeout) via the serial communication port.
[55]	Pulse output	
[122]	No alarm	
[125]	Hand mode	Output is high when the unit is in hand on mode (as indicated by the LED light above [Hand on]).
[126]	Auto mode	
[152]	AF sleeping	

5-31 Terminal 29 Digital Output		
Option:	Function:	
[0] *	No operation	Functions are described under 5-3* Digital Outputs This parameter only applies to FC 302

6.4.4 5-4* Relays

Parameters for configuring the timing and the output functions for the relays.

5-40 Function Relay		
Option:	Function:	
[0]	No operation	
[128]	SC contactor	
[129]	Mains contactor	

5-41 On Delay, Relay		
Array [9], (Relay 1 [0], Relay 2 [1], Relay 3 [2], Relay 4 [3], Relay 5 [4], Relay 6 [5], Relay 7 [6], Relay 8 [7], Relay 9 [8])		
Range:	Function:	
0.01 s* [0.01 - 600.00 s]	Enter the delay of the relay cut-in time. Select one of available mechanical relays and MCB 105 in an array function. See 5-40 Function Relay. Relay 3-6 are included in MCB 113.	

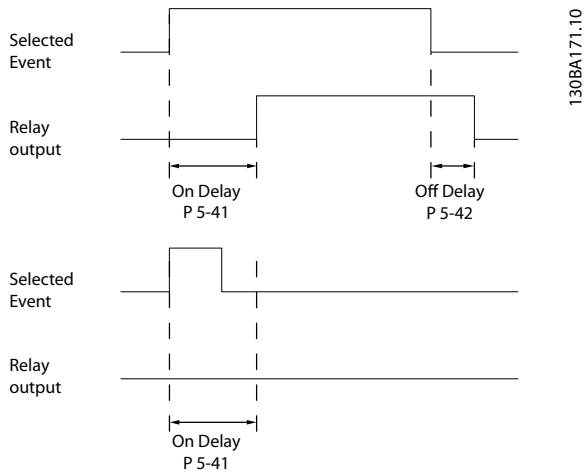

5-42 Off Delay, Relay		
Array [9] (Relay 1 [0], Relay 2 [1], Relay 3 [2], Relay 4 [3], Relay 5 [4], Relay 6 [5], Relay 7 [6], Relay 8 [7], Relay 9 [8])		
Range:	Function:	
0.01 s* [0.01 - 600.00 s]	Enter the delay of the relay cut-out time. Select one of available mechanical relays and MCB 105 in an array function. See 5-40 Function Relay.	

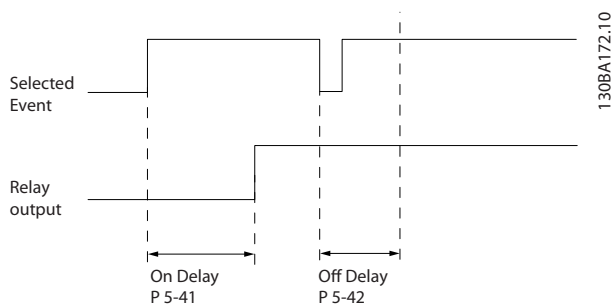

If the selected event condition changes before the on or off delay timer expires, the relay output is unaffected.

6.5 8-** General Settings

6.5.1 8-0* General Settings

8-01 Control Site		
Option:	Function:	
		The setting in this parameter overrides the settings in 8-50 Coasting Select to 8-56 Preset Reference Select.
[0] *	Digital and ctrl. word	Control by using both digital input and control word.
[1]	Digital only	Control by using digital inputs only.
[2]	Control word only	Control by using control word only.

8-02 Control Word Source

Select the source of the control word: one of two serial interfaces or four installed options. During initial power-up, the unit automatically sets this parameter to *Option A* [3] if it detects a valid Serial communication bus option installed in slot A. If the option is removed, the unit detects a change in the configuration, sets 8-02 Control Word Source back to default setting FC RS-485, and the unit then trips. If an option is installed after initial power-up, the setting of 8-02 Control Word Source will not change but the unit will trip and display: Alarm 67 Option Changed.

When you retrofit a bus option into a Adjustable frequency drive that did not have a bus option installed to begin with, you must take an ACTIVE decision to move the control to bus-based. This is done for safety reasons in order to avoid an accidental change. This parameter cannot be adjusted while the motor is running.

Option:	Function:	
[0]	None	
[1]	FC RS485	
[2]	FC USB	
[3] *	Option A	
[4]	Option B	
[5]	Option C0	
[6]	Option C1	
[30]	External Can	

8-03 Control Word Timeout Time		
Range:	Function:	
1.0 s* [Application dependant]	Enter the maximum time expected to pass between the reception of two consecutive messages. If this time is exceeded, it indicates that the serial communication has stopped. The function selected in 8-04 Control Word Timeout Function will then be carried	

8-03 Control Word Timeout Time	
Range:	Function:
	out. The timeout counter is triggered by a valid control word.

8-04 Control Word Timeout Function
 Select the timeout function. The timeout function activates when the control word fails to be updated within the time period specified in *8-03 Control Word Timeout Time*.

Option:	Function:
[0] * Off	Resumes control via serial bus (Serial communication bus or standard) using the most recent control word.
[1] Freeze output	Freezes output frequency until communication resumes.
[2] Stop	Stops with auto-restart when communication resumes.
[3] Jogging	Runs the motor at JOG frequency until communication resumes.
[4] Max. speed	Runs the motor at maximum frequency until communication resumes.
[5] Stop and trip	Stops the motor, then resets the unit in order to restart: via the Serial communication bus, via the reset button on the LCP or via a digital input.
[7] Select setup 1	Changes the set-up upon reestablishment of communication following a control word timeout. If communication resumes causing the timeout situation to disappear, <i>8-05 End-of-Timeout Function</i> defines whether to resume the set-up used before the timeout or to retain the set-up endorsed by the timeout function.
[8] Select setup 2	See [7] <i>Select set-up 1</i>
[9] Select setup 3	See [7] <i>Select set-up 1</i>
[10] Select setup 4	See [7] <i>Select set-up 1</i>

NOTE!

The following configuration is required in order to change the set-up after a timeout:
 Set *0-10 Active Set-up* to [9] *Multi set-up* and select the relevant link in *0-12 This Set-up Linked to*.

8-05 End-of-Timeout Function	
Option:	Function:
	Select the action after receiving a valid control word following a timeout. This parameter is active only when <i>8-04 Control Word Timeout Function</i> is set to [Set-up 1-4].

8-05 End-of-Timeout Function		
Option:	Function:	
[0]	Hold set-up	Retains the set-up selected in <i>8-04 Control Word Timeout Function</i> and displays a warning, until <i>8-06 Reset Control Timeout</i> toggles. Then the unit resumes its original set-up.
[1] *	Resume set-up	Resumes the set-up active prior to the timeout.

8-06 Reset Control Word Timeout		
This parameter is active only when <i>Hold set-up</i> [0] has been selected in <i>8-05 End-of-Timeout Function</i> .		
Option:	Function:	
[0] *	Do not reset	Retains the set-up specified in <i>8-04 Control Word Timeout Function</i> , following a control word timeout.
[1]	Do reset	Returns the unit to the original set-up following a control word timeout. The unit performs the reset and then immediately reverts to the <i>Do not reset</i> [0] setting

6.5.2 8-3* FC Port Settings

8-30 Protocol		
Option:	Function:	
[0] *	FC	Communication according to the FC Protocol as described in the <i>VLT AutomationDrive Design Guide, RS485 Installation and Set-up</i> .
[1]	FC MC	Select the protocol for the FC (standard) port.
[2] *	Modbus RTU	

8-31 Address		
Range:	Function:	
Application dependent*	[Application dependant]	

8-32 FC Port Baud Rate		
Option:	Function:	
[0]	2400 Baud	Baud rate selection for the FC (standard) port.
[1]	4800 Baud	
[2] *	9600 Baud	
[3]	19200 Baud	
[4]	38400 Baud	
[5]	57600 Baud	
[6]	76800 Baud	
[7]	115200 Baud	

8-35 Minimum Response Delay		
Range:		Function:
10 ms*	[Application dependant]	Specify the minimum delay time between receiving a request and transmitting a response. This is used for overcoming modem turnaround delays.

8-36 Max Response Delay		
Range:		Function:
Application dependent*	[Application dependant]	Specify the maximum permissible delay time between transmitting a request and receiving a response. Exceeding this delay time will cause control word timeout.

8-37 Max Inter-Char Delay		
Range:		Function:
Application dependent*	[Application dependant]	Specify the maximum permissible time interval between receiving two bytes. This parameter activates timeout if transmission is interrupted. This parameter is active only when 8-30 Protocol is set to FC MC [1] protocol.

8-53 Start Select		
Option:		Function:
		Select control of the unit start function via the terminals (digital input) and/or via the Serial communication bus.
[0]	Digital input	Activates Start command via a digital input.
[1]	Bus	Activates Start command via the serial communication port or Serial communication bus option.
[2]	Logic AND	Activates Start command via the Serial communication bus/serial communication port, AND additionally via one of the digital inputs.
[3] *	Logic OR	Activates Start command via the Serial communication bus/serial communication port OR via one of the digital inputs.

NOTE!

This parameter is active only when 8-01 Control Site is set to [0] Digital and control word.

8-55 Set-up Select		
Option:		Function:
		Select control of the unit set-up selection via the terminals (digital input) and/or via the Serial communication bus.
[0]	Digital input	Activates the set-up selection via a digital input.
[1]	Bus	Activates the set-up selection via the serial communication port or Serial communication bus option.
[2]	Logic AND	Activates the set-up selection via the Serial communication bus/serial communication port, AND additionally via one of the digital inputs.
[3] *	Logic OR	Activate the set-up selection via the Serial communication bus/serial communication port OR via one of the digital inputs.

NOTE!

This parameter is active only when 8-01 Control Site is set to [0] Digital and control word.

6.6 14-2* Trip Reset

Parameters for configuring auto reset handling, special trip handling and control card self test or initialization.

14-20 Reset Mode		
Option:		Function:
		Select the reset function after tripping. Once reset, the unit can be restarted.
[0] *	Manual reset	Select <i>Manual reset</i> [0] to perform a reset via [RESET] or via the digital inputs.
[1]	Automatic reset x 1	Select <i>Automatic reset x 1...x20</i> [1]-[12] to perform between one and twenty automatic resets after tripping.
[2]	Automatic reset x 2	
[3]	Automatic reset x 3	
[4]	Automatic reset x 4	
[5]	Automatic reset x 5	
[6]	Automatic reset x 6	
[7]	Automatic reset x 7	
[8]	Automatic reset x 8	
[9]	Automatic reset x 9	
[10]	Automatic reset x 10	
[11]	Automatic reset x 15	
[12]	Automatic reset x 20	
[13]	Infinite auto reset	Select <i>Infinite Automatic Reset</i> [13] for continuous resetting after tripping.
[14]	Reset at power-up	

NOTE!

The filter may start without warning. If the specified number of AUTOMATIC RESETs is reached within 10 minutes, the unit enters Manual reset [0] mode. After the Manual reset is performed, the setting of 14-20 Reset Mode reverts to the original selection. If the number of automatic resets is not reached within 10 minutes, or when a Manual reset is performed, the internal AUTOMATIC RESET counter returns to zero.

14-21 Automatic Restart Time		
Range:		Function:
10 s*	[0 - 600 s]	Enter the time interval from trip to start of the automatic reset function. This parameter is active when 14-20 Reset Mode is set to <i>Automatic reset</i> [1] - [13].

14-22 Operation Mode	
Option:	Function:
	<p>Use this parameter to specify normal operation, to perform tests or to initialize all parameters except 15-03 Power-ups, 15-04 Over Temps and 15-05 Over Volts. This function is active only when the power is cycled to the unit.</p> <p>Select <i>Normal operation</i> [0] for normal operation of the unit.</p> <p>Select <i>Control card test</i> [1] to test the analog and digital inputs and outputs and the +10 V control voltage. The test requires a test connector with internal connections. Use the following procedure for the control card test:</p> <ol style="list-style-type: none"> Select <i>Control card test</i> [1]. Disconnect the line power supply and wait for the light in the display to go out. Set switches S201 (A53) and S202 (A54) = 'ON' / I. Insert the test plug (see below). Connect to the line power supply. Carry out various tests. The results are displayed on the LCP and the unit moves into an infinite loop. 14-22 Operation Mode is automatically set to Normal operation. Carry out a power cycle to start up in normal operation after a control card test. <p>If the test is OK: LCP readout: Control Card OK. Disconnect the line power supply and remove the test plug. The green LED on the control card will light up.</p> <p>If the test fails: LCP readout: Control Card I/O failure. Replace the unit or control card. The red LED on the control card is turned on. Test plugs (connect the following terminals to each other): 18 - 27 - 32; 19 - 29 - 33; 42 - 53 - 54</p>

14-22 Operation Mode		
Option:	Function:	
	<p>Select <i>Initialization</i> [2] to reset all parameter values to default settings, except for <i>15-03 Power-ups</i>, <i>15-04 Over Temps</i> and <i>15-05 Over Volts</i>. The unit will reset during the next power-up.</p> <p><i>14-22 Operation Mode</i> will also revert to the default setting <i>Normal operation</i> [0].</p>	
[0] *	Normal operation	
[1]	Control card test	
[2]	Initialisation	
[3]	Boot mode	

14-29 Service Code		
Range:	Function:	
0*	[-2147483647 - 2147483647]	For internal service only.

14-50 RFI 1		
Option:	Function:	
[0]	Off	Select <i>Off</i> [0] only if the unit is fed by an isolated line power source (IT line power). In this mode, the internal RFI filter capacitors between chassis and the line power RFI filter circuit are cut-out to reduce the ground capacity currents.
[1] *	On	Select <i>On</i> [1] to ensure that the unit complies with EMC standards.

14-54 Bus Partner		
Range:	Function:	
1*	[0 - 126]	

6.7 15-0* Operating Data

Parameter group containing filter information such as operating data, hardware configuration and software versions.

6.7.1 15-0* Operating Data

15-00 Operating Hours		
Range:	Function:	
0 h* [0 - 2147483647 h]	View how many hours the unit has run. The value is saved when the unit is turned off.	

15-01 Running Hours		
Range:	Function:	
0 h* [0 - 2147483647 h]	View how many hours the filter has run. Reset the counter in <i>15-07 Reset Running Hours Counter</i> . The value is saved when the unit is turned off.	

15-03 Power-ups		
Range:	Function:	
0* [0 - 2147483647]	View the number of times the unit has been powered up.	

15-04 Over Temps		
Range:	Function:	
0* [0 - 65535]	View the number of unit temperature faults which have occurred.	

15-05 Over Volts		
Range:	Function:	
0* [0 - 65535]	View the number of unit overvoltages which have occurred.	

15-07 Reset Running Hours Counter		
Option:	Function:	
[0] * Do not reset		
[1] Reset counter	Select <i>Reset</i> [1] and press [OK] to reset the Running Hours counter to zero (see <i>15-01 Running Hours</i>). This parameter cannot be selected via the serial port, RS-485. Select <i>Do not reset</i> [0] if no reset of the Running Hours counter is desired.	

Event) and window (*15-14 Samples Before Trigger*) are used to start and stop the logging conditionally.

15-10 Logging Source		
Array [4]		
Option:	Function:	
	Select which variables are to be logged.	
[0] *	None	
[1600]	Control Word	
[1603]	Status Word	
[1630]	DC Link Voltage	
[1634]	Heatsink Temp.	
[1635]	Inverter Thermal	
[1660]	Digital Input	
[1666]	Digital Output [bin]	
[1690]	Alarm Word	
[1692]	Warning Word	
[1694]	Ext. Status Word	

15-11 Logging Interval		
Range:	Function:	
Application dependent*	[Application dependant]	Enter the interval in milliseconds between each sampling of the variables to be logged.

15-12 Trigger Event		
Select the trigger event. When the trigger event occurs, a window is applied to freeze the log. The log will then retain a specified percentage of samples before the occurrence of the trigger event (<i>15-14 Samples Before Trigger</i>).		

Option:	Function:	
[0] *	False	
[1]	True	
[2]	Running	
[6]	Current limit	
[16]	Thermal warning	
[19]	Warning	
[20]	Alarm (trip)	
[21]	Alarm (trip lock)	
[33]	Digital input DI18	
[34]	Digital input DI19	
[35]	Digital input DI27	
[36]	Digital input DI29	

6.7.2 15-1* Data Log Settings

The Data Log enables continuous logging of up to 4 data sources (*15-10 Logging Source*) at individual rates (*15-11 Logging Interval*). A trigger event (*15-12 Trigger*

15-13 Logging Mode		
Option:	Function:	
[0] *	Log always	Select <i>Log always</i> [0] for continuous logging.
[1]	Log once on trigger	Select <i>Log once on trigger</i> [1] to conditionally start and stop logging using <i>15-12 Trigger Event</i> and <i>15-14 Samples Before Trigger</i> .

15-14 Samples Before Trigger		
Range:	Function:	
50*	[0 - 100]	Enter the percentage of all samples prior to a trigger event which are to be retained in the log. See also <i>15-12 Trigger Event</i> and <i>15-13 Logging Mode</i> .

6.7.3 15-2* Historic Log

View up to 50 logged data items via the array parameters in this parameter group. For all parameters in the group, [0] is the most recent data and [49] the oldest data. Data is logged every time an *event* occurs (not to be confused with SLC events). *Events* in this context are defined as a change in one of the following areas:

1. Digital input
2. Digital outputs (not monitored in this SW release)
3. Warning word
4. Alarm word
5. Status word
6. Control word
7. Extended status word

Events are logged with value, and time stamp in msec. The time interval between two events depends on how often *events* occur (maximum once every scan time). Data logging is continuous but if an alarm occurs, the log is saved and the values can be viewed on the display. This feature is useful, for example when carrying out service following a trip. View the historic log contained in this parameter via the serial communication port or via the display.

15-20 Historic Log: Event		
Array [50]		
Range:	Function:	
0*	[0 - 255]	View the event type of the logged events.

15-21 Historic Log: Value		
Array [50]		
Range:	Function:	
0*	[0 - 2147483647]	View the value of the logged event. Interpret the event values according to this table:
	Digital input	Decimal value. See <i>16-60 Digital Input</i> for description after converting to binary value.
	Digital output (not monitored in this SW release)	Decimal value. See <i>16-66 Digital Output [bin]</i> for description after converting to binary value.
	Warning word	Decimal value. See <i>16-92 Warning Word</i> for description.
	Alarm word	Decimal value. See <i>16-90 Alarm Word</i> for description.
	Status word	Decimal value. See <i>16-03 Status Word</i> for description after converting to binary value.
	Control word	Decimal value. See <i>16-00 Control Word</i> for description.
	Extended status word	Decimal value. See <i>16-94 Ext. Status Word</i> for description.

15-22 Historic Log: Time		
Array [50]		
Range:	Function:	
0 ms*	[0 - 2147483647 ms]	View the time at which the logged event occurred. Time is measured in ms since unit start. The max. value corresponds to approx. 24 days which means that the count will restart at zero after this time period.

6.7.4 15-3* Alarm Log

Parameters in this group are array parameters, where up to 10 fault logs can be viewed. [0] is the most recent logged data, and [9] the oldest. Error codes, values and time stamp can be viewed for all logged data.

15-30 Fault Log: Error Code		
Array [10]		
Range:	Function:	
0*	[0 - 255]	View the error code and look up its meaning in the <i>Troubleshooting</i> chapter of the VLT AutomationDrive Design Guide.

15-31 Alarm Log: Value		
Array [10]		
Range:	Function:	
0*	[-32767 - 32767]	View an extra description of the error. This parameter is mostly used in combination with alarm 38 'internal fault'.

15-32 Alarm Log: Time		
Array [10]		
Range:	Function:	
0 s*	[0 - 2147483647 s]	View the time when the logged event occurred. Time is measured in seconds from unit start-up.

6.7.5 15-4* Unit Identification

Parameters containing read-only information about the hardware and software configuration of the active filter.

15-40 FC Type		
Range:	Function:	
0*	[0 - 0]	View the FC type. The readout is identical to the FC 300 Series power field of the type code definition, characters 1-6.

15-41 Power Section		
Range:	Function:	
0*	[0 - 0]	View the FC type. The readout is identical to the FC 300 Series power field of the type code definition, characters 7-10.

15-42 Voltage		
Range:	Function:	
0*	[0 - 0]	View the FC type. The readout is identical to the power field of the type code definition, characters 11-12.

15-43 Software Version		
Range:	Function:	
0*	[0 - 0]	View the combined SW version (or 'package version') consisting of power SW and control SW.

15-44 Ordered Typecode String		
Range:	Function:	
0*	[0 - 0]	View the type code string used for re-ordering the active filter in its original configuration.

15-45 Actual Typecode String		
Range:	Function:	
0*	[0 - 0]	View the actual type code string.

15-46 Unit Ordering No		
Range:	Function:	
0 N/A*	[0-0 N/A]	View the 8-digit ordering number used for re-ordering the active filter in its original configuration.

15-47 Power Card Ordering No.		
Range:	Function:	
0*	[0 - 0]	View the power card ordering number.

15-48 LCP ID Num.		
Range:	Function:	
0*	[0 - 0]	View the LCP ID number.

15-49 SW ID Control Card		
Range:	Function:	
0*	[0 - 0]	View the control card software version number.

15-50 SW ID Power Card		
Range:	Function:	
0*	[0 - 0]	View the power card software version number.

15-51 Unit Serial Number		
Range:	Function:	
0 N/A*	[0-0 N/A]	View the active filter serial number.

15-53 Power Card Serial Number		
Range:	Function:	
0*	[0 - 0]	View the power card serial number.

6.7.6 15-6* Option Ident.

This read-only parameter group contains information about the hardware and software configuration of the options installed in slots A, B, C0 and C1.

15-60 Option Mounted		
Range:	Function:	
0*	[0 - 0]	View the installed option type.

15-61 Option SW Version		
Range:	Function:	
0*	[0 - 0]	View the installed option software version.

15-62 Option Ordering No		
Range:	Function:	
0*	[0 - 0]	Shows the ordering number for the installed options.

15-63 Option Serial No		
Range:	Function:	
0*	[0 - 0]	View the installed option serial number.

15-70 Option in Slot A		
Range:	Function:	
0*	[0 - 0]	View the type code string for the option installed in slot A, and a translation of the type code string; for example, for type code string 'AX' the translation is 'No option'.

15-71 Slot A Option SW Version		
Range:	Function:	
0*	[0 - 0]	View the software version for the option installed in slot A.

15-72 Option in Slot B		
Range:	Function:	
0*	[0 - 0]	View the type code string for the option installed in slot B, and a translation of the type code string; for example, for type code string 'BX' the translation is 'No option'.

15-73 Slot B Option SW Version		
Range:	Function:	
0*	[0 - 0]	View the software version for the option installed in slot B.

15-74 Option in Slot C0		
Range:	Function:	
0*	[0 - 0]	View the type code string for the option installed in slot C, and a translation of the type code string; for example, for type code string 'CXXX' the translation is 'No option'.

15-75 Slot C0 Option SW Version		
Range:	Function:	
0*	[0 - 0]	View the software version for the option installed in slot C.

15-76 Option in Slot C1		
Range:	Function:	
0*	[0 - 0]	Shows the typecode string for the options (CXXXX if no option) and the translation, e.g., >No option<.

15-77 Slot C1 Option SW Version		
Range:	Function:	
0*	[0 - 0]	Software version for the installed option in option slot C.

15-92 Defined Parameters		
Array [1000]		
Range:	Function:	
0*	[0 - 9999]	View a list of all defined parameters in the active filter. The list ends with 0.

15-93 Modified Parameters		
Array [1000]		
Range:	Function:	
0*	[0 - 9999]	View a list of the parameters that have been changed from their default setting. The list ends with 0. Changes may not be visible until up to 30 seconds after implementation.

15-98 Unit Identification		
Range:	Function:	
0 N/A*	[0-0 N/A]	

15-99 Parameter Metadata		
Array [30]		
Range:	Function:	
0*	[0 - 9999]	This parameter contains data used by the MCT 10 Set-up Software.

6.8 16-0* General Status

16-00 Control Word		
Range:	Function:	
0*	[0 - 65535]	View the control word sent from the unit via the serial communication port in hex code.

16-03 Status Word		
Range:	Function:	
0*	[0 - 65535]	View the status word sent from the unit via the serial communication port in hex code.

16-30 DC Link Voltage		
Range:	Function:	
0 V*	[0 - 10000 V]	View a measured value. The value is filtered with an 30ms time constant.

16-34 Heatsink Temp.		
Range:	Function:	
0 C*	[0 - 255 C]	

16-35 Inverter Thermal		
Range:	Function:	
0 %*	[0 - 100 %]	View the percentage load on the inverter.

16-36 Inv. Nom. Current		
Range:	Function:	
Application dependent*	[0.01 - 10000.00 A]	View the inverter nominal current.

16-37 Inv. Max. Current		
Range:	Function:	
Application dependent*	[0.01 - 10000.00 A]	View the inverter maximum current.

16-39 Control Card Temp.		
Range:	Function:	
0 C*	[0 - 100 C]	

16-40 Logging Buffer Full		
Option:	Function:	
		View whether the logging buffer is full (see parameter group 15-1*). The logging buffer will never be full when 15-13 <i>Logging Mode</i> is set to <i>Log always</i> [0].
[0] *	No	
[1]	Yes	

16-49 Current Fault Source		
Range:	Function:	
0*	[0 - 8]	Value indicates source of current faults including short circuit, overcurrent, and phase imbalance (from left):

16-49 Current Fault Source		
Range:	Function:	
		1-4 Inverter
		5-8 Rectifier
		0 No fault recorded

6.8.1 16-6* Inputs & Outputs

16-60 Digital Input																								
Range:	Function:																							
0*	[0 - 1023]	View the signal states from the active digital inputs. Example: Input 18 corresponds to bit no. 5, '0' = no signal, '1' = connected signal. Bit 6 works in the opposite way, on = '0', off = '1' (safe stop input).																						
		<table border="1"> <tr><td>Bit 0</td><td>Digital input term. 33</td></tr> <tr><td>Bit 1</td><td>Digital input term. 32</td></tr> <tr><td>Bit 2</td><td>Digital input term. 29</td></tr> <tr><td>Bit 3</td><td>Digital input term. 27</td></tr> <tr><td>Bit 4</td><td>Digital input term. 19</td></tr> <tr><td>Bit 5</td><td>Digital input term. 18</td></tr> <tr><td>Bit 6</td><td>Digital input term. 37</td></tr> <tr><td>Bit 7</td><td>Digital input GP I/O term. X30/4</td></tr> <tr><td>Bit 8</td><td>Digital input GP I/O term. X30/3</td></tr> <tr><td>Bit 9</td><td>Digital input GP I/O term. X30/2</td></tr> <tr><td>Bit 10-63</td><td>Reserved for future terminals</td></tr> </table>	Bit 0	Digital input term. 33	Bit 1	Digital input term. 32	Bit 2	Digital input term. 29	Bit 3	Digital input term. 27	Bit 4	Digital input term. 19	Bit 5	Digital input term. 18	Bit 6	Digital input term. 37	Bit 7	Digital input GP I/O term. X30/4	Bit 8	Digital input GP I/O term. X30/3	Bit 9	Digital input GP I/O term. X30/2	Bit 10-63	Reserved for future terminals
Bit 0	Digital input term. 33																							
Bit 1	Digital input term. 32																							
Bit 2	Digital input term. 29																							
Bit 3	Digital input term. 27																							
Bit 4	Digital input term. 19																							
Bit 5	Digital input term. 18																							
Bit 6	Digital input term. 37																							
Bit 7	Digital input GP I/O term. X30/4																							
Bit 8	Digital input GP I/O term. X30/3																							
Bit 9	Digital input GP I/O term. X30/2																							
Bit 10-63	Reserved for future terminals																							

16-66 Digital Output [bin]		
Range:	Function:	
0*	[0 - 15]	View the binary value of all digital outputs.

16-71 Relay Output [bin]		
Range:	Function:	
0*	[0 - 511]	View the settings of all relays. <div style="border: 1px solid black; padding: 5px; width: fit-content; margin: 10px auto;"> <p>Readout choice (Par. 16-71): Relay output (bin):</p> <p style="text-align: right;">130BA195.10</p> <p>0 0 0 0 bin</p> </div>

6.8.2 16-8* Serial communication bus & FC Port

Parameters for reporting the BUS references and control words.

16-80 Fieldbus CTW 1		
Range:	Function:	
0*	[0 - 65535]	View the two-byte control word (CTW) received from the bus master. Interpretation of the control word depends on the Serial communication bus option installed and the control word profile selected in <i>8-10 Control Profile</i> . For more information, please refer to the relevant Serial communication bus manual.

16-84 Comm. Option Status		
Range:	Function:	
0*	[0 - 65535]	View the extended Serial communication bus comm. option status word. For more information, please refer to the relevant Serial communication bus manual.

16-85 FC Port CTW 1		
Range:	Function:	
0*	[0 - 65535]	View the two-byte control word (CTW) received from the bus master. Interpretation of the control word depends on the Serial communication bus option installed and the control word profile selected in <i>8-10 Control Profile</i> .

6.8.3 16-9* Diagnosis Readouts

16-90 Alarm Word		
Range:	Function:	
0*	[0 - 4294967295]	View the alarm word sent via the serial communication port in hex code.

16-91 Alarm Word 2		
Range:	Function:	
0*	[0 - 4294967295]	View the alarm word sent via the serial communication port in hex code.

16-92 Warning Word		
Range:	Function:	
0*	[0 - 4294967295]	View the warning word sent via the serial communication port in hex code.

16-93 Warning Word 2		
Range:	Function:	
0*	[0 - 4294967295]	View the warning word sent via the serial communication port in hex code.

16-94 Ext. Status Word		
Range:	Function:	
0*	[0 - 4294967295]	Returns the extended warning word sent via the serial communication port in hex code.

6.9 300-**

300-00 Harmonic Cancellation Mode		
Option:	Function:	
[0] *	Overall	
[1]	Selective	
[2]	Parallel	Enter the harmonic compensation mode. Selective provides precise compensation of the following harmonics: 5, 7, 11, 13, 17, 19, 23, 25. Overall provides compensation for additional harmonics, but with reduced precision in some cases.

300-20 CT Primary Rating		
Range:	Function:	
Application dependent*	[1 - 4000 A]	Enter the primary rating of the current transformers. For a 1000:5 current transformer, enter 1000. Alternatively, this value can be determined by performing an auto CT detection using parameter 300-29.

300-22 CT Nominal Voltage		
Range:	Function:	
342 V*	[342 - 47250 V]	Enter the network voltage at the location where the CTs are installed. This value will be different than the 300-10 only if a step down transformer is used to connect the active filter. Enter the transformer primary side voltage.

300-24 CT Sequence		
Option:	Function:	
[0] *	L1, L2, L3	
[1]	L1, L3, L2	
[2]	L2, L1, L3	
[3]	L2, L3, L1	
[4]	L3, L1, L2	
[5]	L3, L2, L1	Enter the sequence of the current transformers. Alternatively, this value can be determined by performing an auto CT detection using parameter 300-29.

300-25 CT Polarity		
Option:	Function:	
[0] *	Normal	
[1]	Inverse	Enter the polarity of the current transformers. Alternatively, this value can be determined by performing an auto CT detection using parameter 300-29.

300-26 CT Placement		
Option:	Function:	
[0]	PCC	
[1] *	Load Current	Enter the placement of the current transformers. For a stand-alone active filter installation, the CTs will typically be placed at a PCC.

300-29 Start Auto CT Detection		
Option:	Function:	
[0] *	Off	
[1]	Enable Auto CT Detection	When enabled, the auto CT detection will determine the CT primary rating, CT sequence and CT polarity. CT Secondary Rating, CT Nominal Voltage and CT Placement must be entered by the user before starting the auto CT detection. Automatic CT detection cannot be performed on CTs placed at the load currents.

300-30 Compensation Points		
Range:	Function:	
0.0 A*	[0.0 - 8000.1 A]	Enter the max accepted distortion of the current in amps. Change these values to customize the harmonic compensation. It is possible to change the compensation points for the following harmonics: 5, 7, 11, 13, 17, 19, 23, 25. Selective mode provides compensation of individual harmonics with permitted residual levels on the supply line power. The parameter "Compensation Point" defines the permitted residual level into the supply of the following harmonics.

300-35 Cosphi Reference		
Range:	Function:	
0.500*	[0.500 - 1.000]	Enter the reference for cos-phi.

300-40 Master Follower Selection		
Option:	Function:	
[0]	Master	If operating active filters in parallel, select whether this AF is a master or a follower active filter.
[1]	Follower	
[2] *	Not Paralleled	

⚠ WARNING

Make sure only one master is set in each group of parallel connected filters. Verify that no other unit is set to master.

After changing this parameter, additional parameters are accessible. For the master units, *300-42 Num. of Follower AFs* must be programmed for the amounts of followers (followers) connected.

300-41 Follower ID		
Range:	Function:	
1* [1 - 3]	Enter the unique ID of this follower. Verify that no other follower uses the same ID.	

NOTE!

300-41 Follower ID is not accessible unless *300-40 Master Follower Selection* is set to follower.

⚠ WARNING

Each follower should have its own follower ID. Verify that no other follower has the same follower ID.

300-42 Num. of Follower AFs		
Range:	Function:	
1* [1 - 3]	Enter the total number of follower active filters. The master active filter will only control this number of followers.	

NOTE!

300-42 Num. of Follower AFs is not accessible unless *300-40 Master Follower Selection* is set to master.

Each follower unit has to be programmed at *300-41 Follower ID*. The follower IDs need to be different from one another.

300-50 Enable Sleep Mode		
Option:	Function:	
		This parameter saves energy in light system loads where harmonic distortion is insignificant and mitigation not needed. The filter automatically deactivates when not needed and reactivates when mitigation is called for. The filter still measures harmonics during sleep, but does not inject current. The filter is hardware coded to have a minimum sleep time of 5 sec. to avoid contact bounce.
[0]	Disabled	Default filter does not use the sleep mode function.
[1]	Enabled	The filter enters sleep mode at light loads or if triggered from external.

300-51 Sleep Mode Trig Source		
Option:	Function:	
[0]	Mains current	The filter is active/inactive according to line current. Trigger values are set in <i>300-52 Sleep Mode Wake Up Trigger</i> and <i>300-53 Sleep Mode Sleep Trigger</i>
[1]	Digital Input	Filter sleep is triggered via an external signal provided to filter terminal T18.

300-52 Sleep Mode Wake Up Trigger		
Range:		Function:
Application dependent*	[Application dependant]	Only available when [o] Line Power Current is selected in 300-51 Sleep Mode Trig Source. The parameter sets the current % value of 300-20 CT Primary Rating at which the filter awakes; 5 equals 5% of 300-20 CT Primary Rating. If CTs are 1500 and this parameter is 5, this equals 5% of 1500A = 75A wake-up current.

300-53 Sleep Mode Sleep Trigger		
Range:		Function:
80 %*	[0 - 90 %]	

6.10 301-**

301-00 Output Current [A]		
Range:		Function:
0.00 A*	[0.00 - 10000.00 A]	View the RMS output current of the unit.

301-01 Output Current [%]		
Range:		Function:
0.0 %*	[0.0 - 10000.0 %]	

301-10 THD of Current [%]		
Range:		Function:
0 %*	[0 - 200 %]	

301-11 Estimated THD of Voltage [%]		
Range:		Function:
0%*	[0-200%]	View the total harmonic distortion of the voltage. This value is estimated because the active filter does not measure the AC line voltage.

301-12 Power Factor		
Range:		Function:
0.00*	[0.00 - 2.00]	View the power factor, after compensation by the active filter.

301-13 Cosphi		
Range:		Function:
0.00*	[-1.00 - 2.00]	View the displacement power factor, after compensation by the active filter. Positive numbers indicate a leading power factor, while negative numbers indicate a lagging power factor.

301-14 Leftover Currents		
Range:		Function:
0.0 A*	[0.0 - 8000.0 A]	View the harmonic currents leftover after prioritized harmonic and cos-phi compensation by the active filter.

301-20 Mains Current [A]		
Range:		Function:
0 A*	[0 - 65000 A]	View the total harmonic distortion of the current, after compensation by the active filter.

301-21 Mains Frequency		
Range:		Function:
0 Hz*	[0 - 100 Hz]	View the total harmonic distortion of the voltage.

301-22 Fund. Mains Current [A]		
Range:		Function:
0 A*	[0 - 65000 A]	View the power factor, after compensation by the active filter.

6.11 Parameter Lists

6.11.1 Default settings

Changes during operation:

“TRUE” means that the parameter can be changed while the active filter is in operation and “FALSE” means that the unit must be stopped before a change can be made.

4 set-up:

'All set-up': the parameter can be set individually in each of the four set-ups, i.e., one single parameter can have four different data values.

'1 set-up': the data value will be the same in all set-ups.

6

SR:

Size related

N/A:

No default value available.

Conversion index:

This number refers to a conversion figure used when writing or reading using an active filter.

Conv. index	100	75	74	70	67	6	5	4	3	2	1	0	-1	-2	-3	-4	-5	-6
Conv. factor	1	3,600,00 0	3,60 0	60	1/60	1,000,0 00	100,00 0	10,00 0	1,000	100	10	1	0.1	0.01	0.001	0.000 1	0.00001	0.00000 1

Data type	Description	Type
2	Integer 8	Int8
3	Integer 16	Int16
4	Integer 32	Int32
5	Unsigned 8	UInt8
6	Unsigned 16	UInt16
7	Unsigned 32	UInt32
9	Visible String	VisStr
33	Normalized value 2 bytes	N2
35	Bit sequence of 16 Boolean variables	V2
54	Time difference w/o date	TimD

6.11.2 Operation/Display 0-**

Par. No. #	Parameter description	Default value	4-set-up	FC 302 only	Change during operation	Conversion index	Type
0-0* Basic Settings							
0-01	Language	[0] English	1 set-up		TRUE	-	Uint8
0-04	Operating State at Power-up (Hand)	[1] Forced stop	All set-ups		TRUE	-	Uint8
0-1* Set-up Operations							
0-10	Active Set-up	[1] Set-up 1	1 set-up		TRUE	-	Uint8
0-11	Edit Set-up	[1] Set-up 1	All set-ups		TRUE	-	Uint8
0-12	This Set-up Linked to	[0] Not linked	All set-ups		FALSE	-	Uint8
0-13	Readout: Linked Set-ups	0 N/A	All set-ups		FALSE	0	Uint16
0-14	Readout: Edit Set-ups / Channel	0 N/A	All set-ups		TRUE	0	Int32
0-2* LCP Display							
0-20	Display Line 1.1 Small	30112	All set-ups		TRUE	-	Uint16
0-21	Display Line 1.2 Small	30110	All set-ups		TRUE	-	Uint16
0-22	Display Line 1.3 Small	30120	All set-ups		TRUE	-	Uint16
0-23	Display Line 2 Large	30100	All set-ups		TRUE	-	Uint16
0-24	Display Line 3 Large	30121	All set-ups		TRUE	-	Uint16
0-25	My Personal Menu	ExpressionLimit	1 set-up		TRUE	0	Uint16
0-4* LCP Keypad							
0-40	[Hand on] Key on LCP	[1] Enabled	All set-ups		TRUE	-	Uint8
0-41	[Off] Key on LCP	[1] Enabled	All set-ups		TRUE	-	Uint8
0-42	[Auto on] Key on LCP	[1] Enabled	All set-ups		TRUE	-	Uint8
0-43	[Reset] Key on LCP	[1] Enabled	All set-ups		TRUE	-	Uint8
0-5* Copy/Save							
0-50	LCP Copy	[0] No copy	All set-ups		FALSE	-	Uint8
0-51	Set-up Copy	[0] No copy	All set-ups		FALSE	-	Uint8
0-6* Password							
0-60	Main Menu Password	100 N/A	1 set-up		TRUE	0	Int16
0-61	Access to Main Menu w/o Password	[0] Full access	1 set-up		TRUE	-	Uint8
0-65	Quick Menu Password	200 N/A	1 set-up		TRUE	0	Int16
0-66	Access to Quick Menu w/o Password	[0] Full access	1 set-up		TRUE	-	Uint8

6.11.3 Digital In/Out 5-**

Par. No. #	Parameter description	Default value	4-set-up	FC 302 only	Change during operation	Conversion index	Type
5-0* Digital I/O mode							
5-00	Digital I/O Mode	[0] PNP	All set-ups		FALSE	-	Uint8
5-01	Terminal 27 Mode	[0] Input	All set-ups		TRUE	-	Uint8
5-02	Terminal 29 Mode	[0] Input	All set-ups	x	TRUE	-	Uint8
5-1* Digital Inputs							
5-10	Terminal 18 Digital Input	[8] Start	All set-ups		TRUE	-	Uint8
5-11	Terminal 19 Digital Input	[0] No operation	All set-ups		TRUE	-	Uint8
5-12	Terminal 27 Digital Input	[0] No operation	All set-ups		TRUE	-	Uint8
5-13	Terminal 29 Digital Input	[0] No operation	All set-ups		TRUE	-	Uint8
5-14	Terminal 32 Digital Input	[90] AC Contactor	All set-ups		TRUE	-	Uint8
5-15	Terminal 33 Digital Input	[91] DC Contactor	All set-ups		TRUE	-	Uint8
5-16	Terminal X30/2 Digital Input	[0] No operation	All set-ups		TRUE	-	Uint8
5-17	Terminal X30/3 Digital Input	[0] No operation	All set-ups		TRUE	-	Uint8
5-18	Terminal X30/4 Digital Input	[0] No operation	All set-ups		TRUE	-	Uint8
5-19	Terminal 37 Safe Stop	[1] Safe Stop Alarm	1 set-up		TRUE	-	Uint8
5-3* Digital Outputs							
5-30	Terminal 27 Digital Output	[0] No operation	All set-ups		TRUE	-	Uint8
5-31	Terminal 29 Digital Output	[0] No operation	All set-ups	x	TRUE	-	Uint8
5-4* Relays							
5-40	Function Relay	[0] No operation	All set-ups		TRUE	-	Uint8
5-41	On Delay, Relay	0.30 s	All set-ups		TRUE	-2	Uint16
5-42	Off Delay, Relay	0.30 s	All set-ups		TRUE	-2	Uint16

6.11.4 Comm. and Options 8-**

Par. No. #	Parameter description	Default value	4-set-up	FC 302 only	Change during operation	Conversion index	Type
8-0* General Settings							
8-01	Control Site	[0] Digital and ctrl.word	All set-ups		TRUE	-	Uint8
8-02	Control Word Source	null	All set-ups		TRUE	-	Uint8
8-03	Control Word Timeout Time	1.0 s	1 set-up		TRUE	-1	Uint32
8-04	Control Word Timeout Function	[0] Off	1 set-up		TRUE	-	Uint8
8-05	End-of-Timeout Function	[1] Resume set-up	1 set-up		TRUE	-	Uint8
8-06	Reset Control Word Timeout	[0] Do not reset	All set-ups		TRUE	-	Uint8
8-3* FC Port Settings							
8-30	Protocol	[1] FC MC	1 set-up		TRUE	-	Uint8
8-31	Address	2 N/A	1 set-up		TRUE	0	Uint8
8-32	FC Port Baud Rate	[2] 9600 Baud	1 set-up		TRUE	-	Uint8
8-35	Minimum Response Delay	10 ms	All set-ups		TRUE	-3	Uint16
8-36	Max Response Delay	5000 ms	1 set-up		TRUE	-3	Uint16
8-37	Max Inter-Char Delay	25 ms	1 set-up		TRUE	-3	Uint16
8-5* Digital/Bus							
8-53	Start Select	[3] Logic OR	All set-ups		TRUE	-	Uint8
8-55	Set-up Select	[3] Logic OR	All set-ups		TRUE	-	Uint8

6.11.5 Special Functions 14-**

Par. No. #	Parameter description	Default value	4-set-up	FC 302 only	Change during operation	Conversion index	Type
14-2* Trip Reset							
14-20	Reset Mode	[0] Manual reset	All set-ups		TRUE	-	Uint8
14-21	Automatic Restart Time	10 s	All set-ups		TRUE	0	Uint16
14-22	Operation Mode	[0] Normal operation	All set-ups		TRUE	-	Uint8
14-23	Typecode Setting	null	2 set-ups		FALSE	-	Uint8
14-28	Production Settings	[0] No action	All set-ups		TRUE	-	Uint8
14-29	Service Code	0 N/A	All set-ups		TRUE	0	Int32
14-5* Environment							
14-50	RFI filter	[1] On	1 set-up		FALSE	-	Uint8
14-53	Fan Monitor	[1] Warning	All set-ups		TRUE	-	Uint8
14-54	Bus Partner	1 N/A	2 set-ups		TRUE	0	Uint16

6.11.6 Adj. Freq. Drive Information 15-**

Par. No. #	Parameter description	Default value	4-set-up	FC 302 only	Change during operation	Conversion index	Type
15-0* Operating Data							
15-00	Operating Hours	0 h	All set-ups		FALSE	74	Uint32
15-01	Running Hours	0 h	All set-ups		FALSE	74	Uint32
15-03	Power-ups	0 N/A	All set-ups		FALSE	0	Uint32
15-04	Over Temps	0 N/A	All set-ups		FALSE	0	Uint16
15-05	Over Volts	0 N/A	All set-ups		FALSE	0	Uint16
15-07	Reset Running Hours Counter	[0] Do not reset	All set-ups		TRUE	-	Uint8
15-1* Data Log Settings							
15-10	Logging Source	0	2 set-ups		TRUE	-	Uint16
15-11	Logging Interval	ExpressionLimit	2 set-ups		TRUE	-3	TimD
15-12	Trigger Event	[0] False	1 set-up		TRUE	-	Uint8
15-13	Logging Mode	[0] Log always	2 set-ups		TRUE	-	Uint8
15-14	Samples Before Trigger	50 N/A	2 set-ups		TRUE	0	Uint8
15-2* Historic Log							
15-20	Historic Log: Event	0 N/A	All set-ups		FALSE	0	Uint8
15-21	Historic Log: Value	0 N/A	All set-ups		FALSE	0	Uint32
15-22	Historic Log: Time	0 ms	All set-ups		FALSE	-3	Uint32
15-3* Fault Log							
15-30	Fault Log: Error Code	0 N/A	All set-ups		FALSE	0	Uint16
15-31	Fault Log: Value	0 N/A	All set-ups		FALSE	0	Int16
15-32	Fault Log: Time	0 s	All set-ups		FALSE	0	Uint32
15-4* Unit Identification							
15-40	FC Type	0 N/A	All set-ups		FALSE	0	VisStr[6]
15-41	Power Section	0 N/A	All set-ups		FALSE	0	VisStr[20]
15-42	Voltage	0 N/A	All set-ups		FALSE	0	VisStr[20]
15-43	Software Version	0 N/A	All set-ups		FALSE	0	VisStr[5]
15-44	Ordered Typecode String	0 N/A	All set-ups		FALSE	0	VisStr[40]
15-45	Actual Typecode String	0 N/A	All set-ups		FALSE	0	VisStr[40]
15-46	Unit Ordering No	0 N/A	All set-ups		FALSE	0	VisStr[8]
15-47	Power Card Ordering No	0 N/A	All set-ups		FALSE	0	VisStr[8]
15-48	LCP ID No	0 N/A	All set-ups		FALSE	0	VisStr[20]
15-49	SW ID Control Card	0 N/A	All set-ups		FALSE	0	VisStr[20]
15-50	SW ID Power Card	0 N/A	All set-ups		FALSE	0	VisStr[20]
15-51	Unit Serial Number	0 N/A	All set-ups		FALSE	0	VisStr[10]
15-53	Power Card Serial Number	0 N/A	All set-ups		FALSE	0	VisStr[19]
15-6* Option Ident							
15-60	Option Mounted	0 N/A	All set-ups		FALSE	0	VisStr[30]
15-61	Option SW Version	0 N/A	All set-ups		FALSE	0	VisStr[20]
15-62	Option Ordering No	0 N/A	All set-ups		FALSE	0	VisStr[8]
15-63	Option Serial No	0 N/A	All set-ups		FALSE	0	VisStr[18]
15-70	Option in Slot A	0 N/A	All set-ups		FALSE	0	VisStr[30]
15-71	Slot A Option SW Version	0 N/A	All set-ups		FALSE	0	VisStr[20]
15-72	Option in Slot B	0 N/A	All set-ups		FALSE	0	VisStr[30]
15-73	Slot B Option SW Version	0 N/A	All set-ups		FALSE	0	VisStr[20]
15-74	Option in Slot C0	0 N/A	All set-ups		FALSE	0	VisStr[30]
15-75	Slot C0 Option SW Version	0 N/A	All set-ups		FALSE	0	VisStr[20]
15-76	Option in Slot C1	0 N/A	All set-ups		FALSE	0	VisStr[30]
15-77	Slot C1 Option SW Version	0 N/A	All set-ups		FALSE	0	VisStr[20]

Par. No. #	Parameter description	Default value	4-set-up	FC 302 only	Change during operation	Conversion index	Type
15-9* Parameter Info							
15-92	Defined Parameters	0 N/A	All set-ups		FALSE	0	Uint16
15-93	Modified Parameters	0 N/A	All set-ups		FALSE	0	Uint16
15-98	Unit Identification	0 N/A	All set-ups		FALSE	0	VisStr[40]
15-99	Parameter Metadata	0 N/A	All set-ups		FALSE	0	Uint16

6.11.7 Data Readouts 16-**

Par. No. #	Parameter description	Default value	4-set-up	FC 302 only	Change during operation	Conversion index	Type
16-0* General Status							
16-00	Control Word	0 N/A	All set-ups		FALSE	0	V2
16-03	Status Word	0 N/A	All set-ups		FALSE	0	V2
16-3* AF Status							
16-30	DC Link Voltage	0 V	All set-ups		FALSE	0	Uint16
16-34	Heatsink Temp.	32°F [0°C]	All set-ups		FALSE	100	Uint8
16-35	Inverter Thermal	0%	All set-ups		FALSE	0	Uint8
16-36	Inv. Nom. Current	ExpressionLimit	All set-ups		FALSE	-2	Uint32
16-37	Inv. Max. Current	ExpressionLimit	All set-ups		FALSE	-2	Uint32
16-39	Control Card Temp.	32°F [0°C]	All set-ups		FALSE	100	Uint8
16-40	Logging Buffer Full	[0] No	All set-ups		TRUE	-	Uint8
16-49	Current Fault Source	0 N/A	All set-ups		TRUE	0	Uint8
16-6* Inputs & Outputs							
16-60	Digital Input	0 N/A	All set-ups		FALSE	0	Uint16
16-66	Digital Output [bin]	0 N/A	All set-ups		FALSE	0	Int16
16-71	Relay Output [bin]	0 N/A	All set-ups		FALSE	0	Int16
16-8* Serial communication bus & FC Port							
16-80	Serial communication bus CTW 1	0 N/A	All set-ups		FALSE	0	V2
16-84	Comm. Option STW	0 N/A	All set-ups		FALSE	0	V2
16-85	FC Port CTW 1	0 N/A	All set-ups		FALSE	0	V2
16-9* Diagnosis Readouts							
16-90	Alarm Word	0 N/A	All set-ups		FALSE	0	Uint32
16-91	Alarm Word 2	0 N/A	All set-ups		FALSE	0	Uint32
16-92	Warning Word	0 N/A	All set-ups		FALSE	0	Uint32
16-93	Warning Word 2	0 N/A	All set-ups		FALSE	0	Uint32
16-94	Ext. Status Word	0 N/A	All set-ups		FALSE	0	Uint32

6.11.8 AF Settings 300-**

NOTE!

Except for 300-10 Active Filter Nominal Voltage, it is not recommended to change the settings in this par. group for the Low Harmonic Drive

Par. No. #	Parameter description	Default value	4-set-up	FC 302 only	Change during operation	Conversion index	Type
300-0* General Settings							
300-00	Harmonic Cancellation Mode	[0] Overall	All set-ups		TRUE	-	Uint8
300-01	Compensation Priority	[0] Harmonics	All set-ups		TRUE	-	Uint8
300-1* Network Settings							
300-10	Active Filter Nominal Voltage	ExpressionLimit	2 set-ups		FALSE	0	Uint32
300-2* CT Settings							
300-20	CT Primary Rating	ExpressionLimit	2 set-ups		FALSE	0	Uint32
300-22	CT Nominal Voltage	342 V	2 set-ups		FALSE	0	Uint32
300-24	CT Sequence	[0] L1, L2, L3	2 set-ups		FALSE	-	Uint8
300-25	CT Polarity	[0] Normal	2 set-ups		FALSE	-	Uint8
300-26	CT Placement	[1] Load Current	2 set-ups		FALSE	-	Uint8
300-29	Start Auto CT Detection	[0] Off	All set-ups		FALSE	-	Uint8
300-3* Compensation							
300-30	Compensation Points	0.0 A	All set-ups		TRUE	-1	Uint32
300-35	Cos-phi Reference	0.500 N/A	All set-ups		TRUE	-3	Uint16
300-4* Paralleling							
300-40	Master Follower Selection	[2] Not Paralleled	2 set-ups		FALSE	-	Uint8
300-41	Follower ID	1 N/A	2 set-ups		FALSE	0	Uint32
300-42	Num. of Follower AFs	1 N/A	2 set-ups		FALSE	0	Uint32
300-5* Sleep Mode							
300-50	Enable Sleep Mode	null	2 set-ups		TRUE	-	Uint8
300-51	Sleep Mode Trig Source	[0] Line power	All set-ups		TRUE	-	Uint8
300-52	Sleep Mode Wake-up Trigger	ExpressionLimit	All set-ups		TRUE	0	Uint32
300-53	Sleep Mode Sleep Trigger	80%	All set-ups		TRUE	0	Uint32

6.11.9 AF Readouts 301-**

Par. No. #	Parameter description	Default value	4-set-up	FC 302 only	Change during operation	Conversion index	Type
301-0* Output Currents							
301-00	Output Current [A]	0.00 A	All set-ups		TRUE	-2	Int32
301-01	Output Current [%]	0.0%	All set-ups		TRUE	-1	Int32
301-1* Unit Performance							
301-10	THD of Current [%]	0.0%	All set-ups		TRUE	-1	Uint16
301-11	Estimated THD of Voltage [%]	0.0%	All set-ups				Uint16
301-12	Power Factor	0.00 N/A	All set-ups		TRUE	-2	Uint16
301-13	Cos-phi	0.00 N/A	All set-ups		TRUE	-2	Int16
301-14	Leftover Currents	0.0 A	All set-ups		TRUE	-1	Uint32
301-2* Line Power Status							
301-20	Line Power Current [A]	0 A	All set-ups		TRUE	0	Int32
301-21	Line Power Frequency	0 Hz	All set-ups		TRUE	0	Uint8
301-22	Fund. Line Power Current [A]	0 A	All set-ups		TRUE	0	Int32

7 RS-485 Installation and set-up

7.1.1 Overview

RS-485 is a two-wire bus interface compatible with multi-drop network topology, i.e., nodes can be connected as a bus, or via drop cables from a common trunk line. A total of 32 nodes can be connected to one network segment. Network segments are divided up by repeaters. Please note that each repeater functions as a node within the segment in which it is installed. Each node connected within a given network must have a unique node address across all segments.

Terminate each segment at both ends, using either the termination switch (S801) of the unit or a biased termination resistor network. Always use shielded twisted pair (STP) cable for bus cabling, and always follow good common installation practice.

Low-impedance ground connection of the shield at every node is very important, also at high frequencies. This can be achieved by connecting a large surface of the shield to ground, by means of a cable clamp or a conductive cable connector, for example. It may be necessary to apply potential-equalizing cables to maintain the same ground potential throughout the network, particularly in installations where there are long lengths of cable. To prevent impedance mismatch, always use the same type of cable throughout the entire network.

Cable: Shielded twisted pair (STP)
Impedance: 120 Ohm
Cable length: Max. 3,396 ft [1,200 m] (including drop lines)
Max. 1,640 ft [500 m] station-to-station

7.1.2 Network Connection

Connect the unit to the RS-485 network as follows (see also diagram):

1. Connect signal wires to terminal 68 (P+) and terminal 69 (N-) on the main control board of the unit.
2. Connect the cable screen to the cable clamps.

NOTE!

Shielded, twisted-pair cables are recommended in order to reduce noise between conductors.

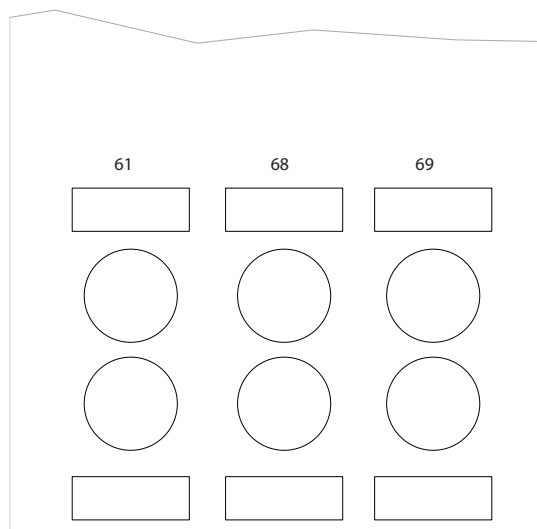

Figure 7.1 Network Terminal Connection

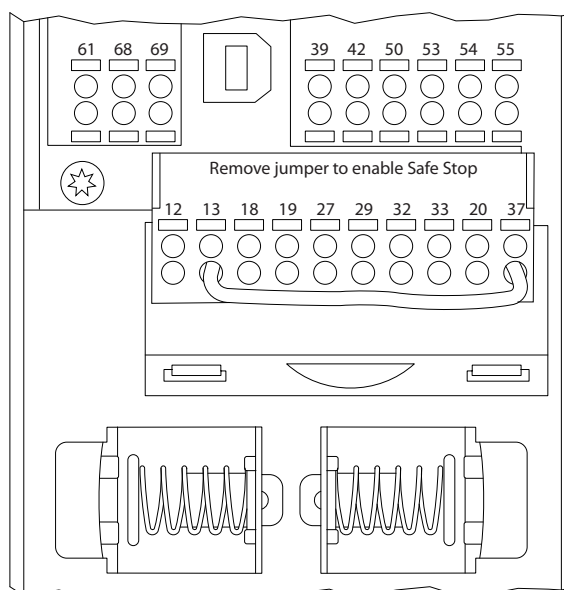

Figure 7.2 Control card terminals

7.1.3 RS-485 Bus Termination

Use the terminator DIP switch on the main control board of the unit to terminate the RS-485 bus.

NOTE!

The factory setting for the DIP switch is OFF.

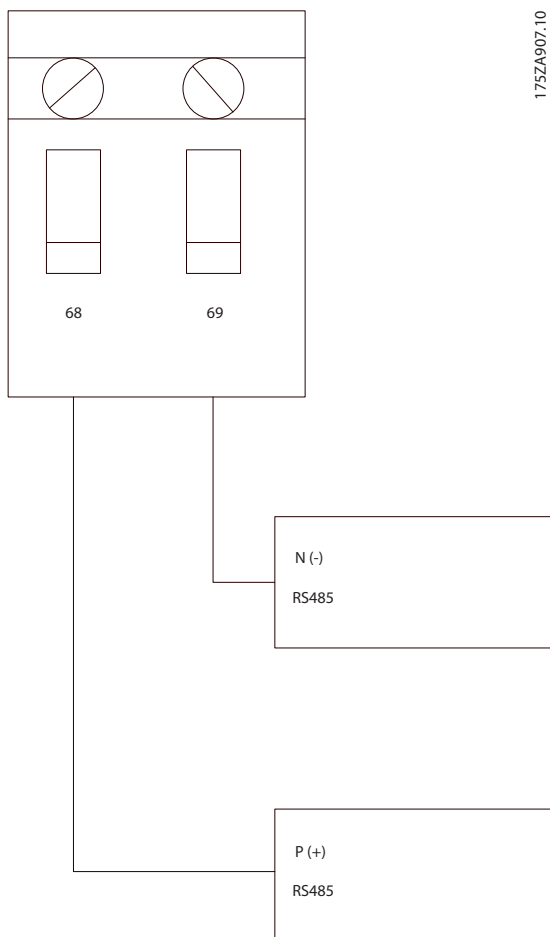

Terminator Switch Factory Setting

7.1.4 EMC Precautions

The following EMC precautions are recommended in order to achieve interference-free operation of the RS-485 network.

Relevant national and local regulations, for example regarding protective ground connection, must be observed. The RS-485 communication cable must be kept away from noisy cables such as power lines and motor cables to avoid coupling of high frequency noise from one cable to another. Normally a distance of 200mm (8 inches) is sufficient, but keeping the greatest possible distance between the cables is generally recommended, especially where cables run in parallel over long distances. When crossing is unavoidable, the RS-485, cable must cross other power cables at an angle of 90°.

The FC protocol, also referred to as FC bus or standard bus, is the Danfoss standard Serial communication bus. It defines an access technique according to the master-slave principle for communications via a serial bus. One master and a maximum of 126 slaves can be connected to the bus. The individual slaves are selected by the master via an address character in the message. A slave itself can never transmit without first being requested to do so, and direct message transfer between the individual slaves is not possible. Communications occur in the half-duplex mode. The master function cannot be transferred to another node (single-master system).

The physical layer is RS-485, thus utilizing the RS-485 port built into the unit. The FC protocol supports different message formats: a short format of 8 bytes for process data, and a long format of 16 bytes that also includes a parameter channel. A third message format is used for texts.

7.2 Network Configuration

7.2.1 VLT AutomationDrive Filter Set-up

Set the following parameters to enable the FC protocol for the filter.

Parameter Number	Setting
8-30 Protocol	FC
8-31 Address	1 - 126
8-32 FC Port Baud Rate	2400 - 115200
8-33 Parity / Stop Bits	Even parity, 1 stop bit (default)

7.3 FC Protocol Message Framing Structure

7.3.1 Content of a Character (byte)

Each character transferred begins with a start bit. Then 8 data bits are transferred, corresponding to a byte. Each character is secured via a parity bit. This bit is set at "1" when it reaches parity. Parity is when there is an equal number of 1s in the 8 data bits and the parity bit in total. A stop bit completes a character, thus consisting of 11 bits in all.

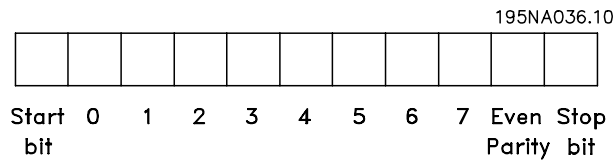

bytes (variable, depending on the type of message) follows. The message is completed by a data control byte (BCC).

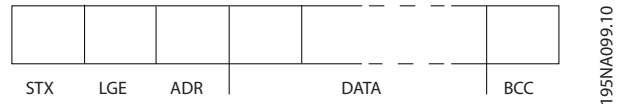

7.3.2 Message Structure

Each message begins with a start character (STX)=02 Hex, followed by a byte denoting the message length (LGE) and a byte denoting the filter address (ADR). A number of data

7.3.3 Message Length (LGE)

The message length is the number of data bytes plus the address byte ADR and the data control byte BCC.

The length of messages with 4 data bytes is	$LGE = 4 + 1 + 1 = 6$ bytes
The length of messages with 12 data bytes is	$LGE = 12 + 1 + 1 = 14$ bytes
The length of messages containing texts is	$10^{1)} + n$ bytes

¹⁾ The 10 represents the fixed characters, while the "n" is variable (depending on the length of the text).

7.3.4 Filter Address (ADR)

Two different address formats are used. The address range of the filter is either 1-31 or 1-126.

- Address format 1-31:
 Bit 7 = 0 (address format 1-31 active)
 Bit 6 is not used
 Bit 5 = 1: Broadcast, address bits (0-4) are not used
 Bit 5 = 0: No Broadcast
 Bit 0-4 = Filter address 1-31

- Address format 1-126:
 Bit 7 = 1 (address format 1-126 active)
 Bit 0-6 = Filter address 1-126
 Bit 0-6 = 0 Broadcast

The slave returns the address byte unchanged to the master in the response message.

7.3.5 Data Control Byte (BCC)

The checksum is calculated as an XOR-function. Before the first byte in the message is received, the calculated checksum is 0.

7.3.6 The Data Field

The structure of data blocks depends on the type of message. There are three message types, and the type applies for both control message (master=>slave) and response messages (slave=>master).

The three types of message are:

Process block (PCD)

The PCD is made up of a data block of 4 bytes (two words) and contains:

- Control word and reference value (from master to slave)
- Status word and present output frequency (from slave to master)



130BA269.10

Parameter block

The parameter block is used to transfer parameters between master and slave. The data block is made up of 12 bytes (6 words) and also contains the process block.

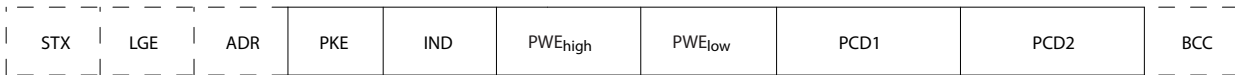

130BA271.10

Text block

The text block is used to read or write texts via the data block.

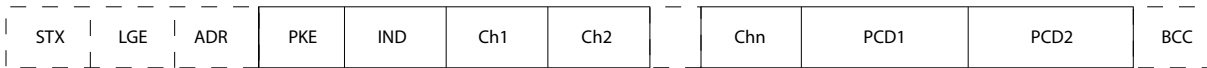

130BA270.10

7

7.3.7 The PKE Field

The PKE field contains two sub-fields: Parameter command and response AK, and parameter number PNU:

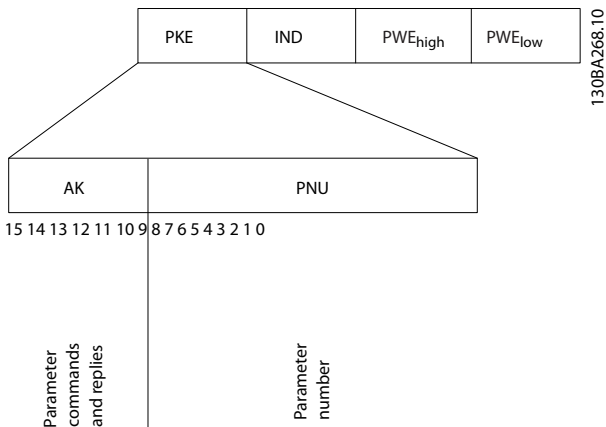

130BA268.10

Bits no. 12-15 transfer parameter commands from master to slave and return processed slave responses to the master.

Parameter commands master → slave				
Bit no.				Parameter command
15	14	13	12	
0	0	0	0	No command
0	0	0	1	Read parameter value
0	0	1	0	Write parameter value in RAM (word)
0	0	1	1	Write parameter value in RAM (double word)
1	1	0	1	Write parameter value in RAM and EEPROM (double word)
1	1	1	0	Write parameter value in RAM and EEPROM (word)
1	1	1	1	Read/write text

Response slave → master				
Bit no.				Response
15	14	13	12	
0	0	0	0	No response
0	0	0	1	Parameter value transferred (word)
0	0	1	0	Parameter value transferred (double word)
0	1	1	1	Command cannot be performed
1	1	1	1	text transferred

If the command cannot be performed, the slave sends this response:

0111 Command cannot be performed

- and issues the following fault report in the parameter value (PWE):

PWE low (Hex)	Fault Report
0	The parameter number used does not exist
1	There is no write access to the defined parameter
2	Data value exceeds the parameter's limits
3	The sub index used does not exist
4	The parameter is not the array type.
5	The data type does not match the defined parameter
11	Data change in the defined parameter is not possible in the unit's present mode. Certain parameters can only be changed when the motor is turned off
82	There is no bus access to the defined parameter
83	Data change is not possible because the factory set-up is selected.

7.3.8 Parameter Number (PNU)

Bits no. 0-11 transfer parameter numbers. The function of the relevant parameter is defined in the parameter description in the Programming Guide.

7.3.9 Index (IND)

The index is used together with the parameter number to read/write-access parameters with an index, e.g., 15-30 Alarm Log: Error Code. The index consists of 2 bytes, a low byte and a high byte.

Only the low byte is used as an index.

7.3.10 Parameter Value (PWE)

The parameter value block consists of 2 words (4 bytes), and the value depends on the defined command (AK). The master prompts for a parameter value when the PWE block contains no value. To change a parameter value (write), write the new value in the PWE block and send from the master to the slave.

When a slave responds to a parameter request (read command), the present parameter value in the PWE block is transferred and returned to the master. If a parameter contains not a numerical value but several data options, e.g., 0-01 Language where [0] corresponds to English, and [4] corresponds to Danish, select the data value by entering the value in the PWE block. See Example -

Selecting a data value. Serial communication is only capable of reading parameters containing data type 9 (text string).

15-40 FC Type to 15-53 Power Card Serial Number contain data type 9.

For example, read the unit size and AC line voltage range in 15-40 FC Type. When a text string is transferred (read), the length of the message is variable, and the texts are of different lengths. The message length is defined in the second byte of the message, LGE. When using text transfer the index character indicates whether it is a read or a write command.

To read a text via the PWE block, set the parameter command (AK) to 'F' Hex. The index character high-byte must be "4".

Some parameters contain text that can be written to via the serial bus. To write a text via the PWE block, set the parameter command (AK) to 'F' Hex. The index characters high-byte must be "5".

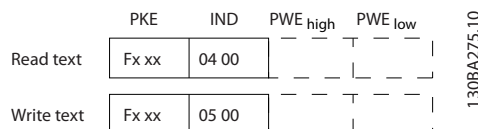

130BA275:10

7.3.11 Data Types Supported by VLT AutomationDrive

Unsigned means that there is no operational sign in the message.

Data types	Description
3	Integer 16
4	Integer 32
5	Unsigned 8
6	Unsigned 16
7	Unsigned 32
9	Text string
10	Byte string
13	Time difference
33	Reserved
35	Bit sequence

7.3.12 Conversion

The various attributes of each parameter are displayed in the section Factory Settings. Parameter values are transferred as whole numbers only. Conversion factors are therefore used to transfer decimals.

4-12 Motor Speed Low Limit [Hz] has a conversion factor of 0.1.

To preset the minimum frequency to 10 Hz, transfer the value 100. A conversion factor of 0.1 means that the value transferred is multiplied by 0.1. The value 100 is thus perceived as 10.0.

Examples:

0s --> conversion index 0

0.00s --> conversion index -2

0ms --> conversion index -3

0.00ms --> conversion index -5

7

Conversion index	Conversion factor
100	
75	
74	
67	
6	1000000
5	100000
4	10000
3	1000
2	100
1	10
0	1
-1	0.1
-2	0.01
-3	0.001
-4	0.0001
-5	0.00001
-6	0.000001
-7	0.0000001

Table 7.1 Conversion table

7.3.13 Process Words (PCD)

The block of process words is divided into two blocks of 16 bits, which always occur in the defined sequence.

PCD 1	PCD 2
Control message (master⇒ slave Control word)	Reference value
Control message (slave ⇒ master) Status word	Present output frequency

7.4 How to Access Parameters

7.4.1 Parameter Handling

The PNU (Parameter Number) is translated from the register address contained in the Modbus read or write message. The parameter number is translated to Modbus as (10 x parameter number) DECIMAL.

7.4.2 Storage of Data

The Coil 65 decimal determines whether data written to the unit is stored in EEPROM and RAM (coil 65 = 1), or only in RAM (coil 65 = 0).

7.4.3 IND

The array index is set in Holding Register 9 and used when accessing array parameters.

7.4.4 Text Blocks

Parameters stored as text strings are accessed in the same way as the other parameters. The maximum text block size is 20 characters. If a read request for a parameter is for more characters than the parameter stores, the response is truncated. If the read request for a parameter is for fewer characters than the parameter stores, the response is padded with spaces.

7.4.5 Conversion Factor

The different attributes for each parameter can be seen in the section on factory settings. Since a parameter value can only be transferred as a whole number, a conversion factor must be used to transfer decimals. Please refer to the *Parameters section*.

7.4.6 Parameter Values

Standard Data Types

Standard data types are int16, int32, uint8, uint16 and uint32. They are stored as 4x registers (40001 – 4FFFF). The parameters are read using function 03HEX "Read Holding Registers." Parameters are written using the function 6HEX "Preset Single Register" for 1 register (16 bits), and the function 10HEX "Preset Multiple Registers" for 2 registers (32 bits). Readable sizes range from 1 register (16 bits) up to 10 registers (20 characters).

Non standard Data Types

Non standard data types are text strings stored as 4x registers (40001–4FFFF). The parameters are read using function 03HEX "Read Holding Registers" and written using function 10HEX "Preset Multiple Registers." Readable sizes range from 1 register (2 characters) up to 10 registers (20 characters).

8 General Specifications

8.1 Electrical Data

8.1.1 Power Rating

Grid conditions:

Supply voltage	380–480V
----------------	----------

AC line voltage low / line drop-out:

During low AC line voltage or a line drop-out, the filter continues until the intermediate circuit voltage drops below the minimum stop level, which corresponds typically to 15% below the filter lowest rated supply voltage. Full compensation cannot be expected at AC line voltage lower than 10% below the filter lowest rated supply voltage. If AC line voltage exceeds the filter highest rated voltage, the filter continues to work but harmonic mitigation performance is reduced. The filter will not cut out until AC line voltages exceed 580V.

Supply frequency	50/60Hz ±5%
------------------	-------------

Max. imbalance temporary between line phases where mitigation performance is kept high.	3.0% of rated supply voltage The filter will mitigate at higher line imbalance but harmonic mitigation performance is reduced 10% with kept mitigation performance
---	--

Max THDv pre-distortion	Reduced performance for higher pre-distortion levels
-------------------------	--

Harmonic Mitigation Performance:

THiD	Best performance <4% Depending on filter vs. distortion ratio.
Individual harmonic mitigation ability:	% of filter current rating
5th	70%
7th	50%
11th	32%
13th	28%
17th	20%
19th	18%
23rd	16%
25th	14%
Total current of harmonics	90%

Reactive Current Compensation:

Cos phi	Controllable 1.0 to 0.5 lagging
Reactive current, % of filter current rating	100%

Cable lengths and cross-sections:

Max grid cable length	Unlimited (determined by voltage drop)
Maximum cross-section to control terminals, rigid wire	1.5mm ² /16 AWG (2 x 0.75 mm ²)
Maximum cross-section to control terminals, flexible cable	1mm ² /18 AWG
Maximum cross-section to control terminals, cable with enclosed core	0.5mm ² /20 AWG
Minimum cross-section to control terminals	0.25mm ²

CT terminals specification:

Necessary CT number	3 (one for each phase)
AAF's burden equals	2mΩ
Secondary current rating	1A or 5A (hardware set-up)
Accuracy	Class 0.5 or better



Digital inputs:

Programmable digital inputs	2 (4)
Terminal number	18, 19, 27*, 29*
Logic	PNP or NPN
Voltage level	0–24V DC
Voltage level, logic '0' PNP	< 5V DC
Voltage level, logic '1' PNP	> 10V DC
Voltage level, logic '0' NPN	> 19V DC
Voltage level, logic '1' NPN	< 14V DC
Maximum voltage on input	28V DC
Input resistance, R_i	approx. 4k Ω

All digital inputs are galvanically isolated from the supply voltage (PELV) and other high-voltage terminals.

*) Terminals 27 and 29 can also be programmed as output.

Control card, RS-485 serial communication:

Terminal number	68 (P,TX+, RX+), 69 (N,TX-, RX-)
Terminal number 61	Common for terminals 68 and 69

The RS-485 serial communication circuit is functionally seated from other central circuits and galvanically isolated from the supply voltage (PELV).

Digital output:

Programmable digital/pulse outputs	2
Terminal number	27, 29 ¹⁾
Voltage level at digital/frequency output	0–24V
Max. output current (sink or source)	40mA

1) Terminal 27 and 29 can also be programmed as input.

Control card, 24 V DC output:

Terminal number	13
Max. load	: 200mA

The 24V DC supply is galvanically isolated from the supply voltage (PELV), but has the same potential as the analog and digital inputs and outputs.

Surroundings:

Vibration test	1.0 g
Relative humidity	5%–95%(IEC 721-3-3; Class 3K3 (non-condensing) during operation
Aggressive environment (IEC 60068-2-43) H ₂ S test	class kD
Test method according to IEC 60068-2-43 H ₂ S (10 days)	
Ambient temperature	
- with derating	max. NA°C
- with full output current (short temperature overload)	max. 113°F [5°C]
- at full continuous output current (24 hours)	max. 113°F [40°C]
Minimum ambient temperature during full-scale operation	32°F [0°C]
Minimum ambient temperature at reduced performance	14°F [-10°C]
Temperature during storage/transport	-58° to 302°F [-25–+70°C]
Maximum altitude above sea level without derating	3280 ft [1000 m]
Maximum altitude above sea level with derating	9842 ft [3000 m]
EMC standards, Emission	EN 61800-3, EN 61000-6-3/4, EN 55011, IEC 61800-3
	EN 61800-3, EN 61000-6-1/2,
EMC standards, Immunity	EN 61000-4-2, EN 61000-4-3, EN 61000-4-4, EN 61000-4-5, EN 61000-4-6

Control card performance:

Scan interval	: 5ms
---------------	-------

Control card, USB serial communication:

USB standard	1.1 (Full speed)
USB plug	USB type B "device" plug

Generic specifications:

Maximum parallel filters	4 on same CT set
Filter Efficiency	97%
Typical average switching frequency	3.0–4.5 kHz
Response time	< 0.5ms
Settling time - reactive current control	< 20ms
Settling time - harmonic current control	< 15ms
Overshoot – reactive current control	<10%
Overshoot – Harmonic current control	<10%

Connection to PC is carried out via a standard host/device USB cable. The USB connection is galvanically isolated from the supply voltage (PELV) and other high-voltage terminals. The USB connection is not galvanically isolated from protection ground. Use only isolated laptop/PC as connection to the USB connector on the unit or an isolated USB cable/driver.

Protection and Features:

- Temperature monitoring of the heatsink ensures that the active filter trips if the temperature reaches a predefined level. An overload temperature cannot be reset until the temperature of the heatsink is below the values stated in the tables on the following pages.
- If a line phase is missing, the active filter trips.
- The active filter has a short circuit protection current rate of 100kA if properly fused
- Monitoring of the intermediate circuit voltage ensures that the filter trips if the intermediate circuit voltage is too low or too high.
- The active filter monitors the line power current as well as internal currents to ensure that current levels do not reach critical levels. If the current exceeds a critical level, the filter trips.

			AAF005A190T4E 21H2GCxx	AAF005A250T4E 21H2GCxx	AAF005A310T4 E21H2GCxx	AAF005A400T4E 21H2GCxx
Total	Current	[A]	190	250	310	400
Losses	Watt	[kW]	5	7	9	11
Needed Airflow		M ³ /h	765	1230	1230	1230
Frame			D	E	E	F
Nominal	Reactive	[A]	190	250	310	400
Nominal	Harmonic	[A]	170	225	280	360
Max individual harmonic compensation in back channel	I ₅	[A]	119	158	196	252
Nominal/ (maximum)	I ₇		85	113	140	180
Note: Numbers are rounded to nearest amp	I ₁₁		54	72	90	115
	I ₁₃		48	63	78	101
	I ₁₇		34	45	56	72
	I ₁₉		31	41	50	65
	I ₂₃		27	36	45	58
	I ₂₅		24	32	39	50

8.1.2 Derating for Low Air Pressure

The cooling capability of air is decreased at a lower air pressure.

Below 3,280 ft [1,000 m] altitude no derating is necessary but above 3,280 ft [1,000 m] the ambient temperature (T_{AMB}) or max. output current (I_{out}) should be derated in accordance with the diagram shown.

An alternative is to lower the ambient temperature at high altitudes and thereby ensure 100% output current at high altitudes. As an example of how to read the graph, the situation at 6,600 ft [2 km] is elaborated. At a temperature of 113°F [45°C] (T_{AMB, MAX} - 3.3 K), 91% of the rated output current is available. At a temperature of 107°F [41.7°C], 100% of the rated output current is available.

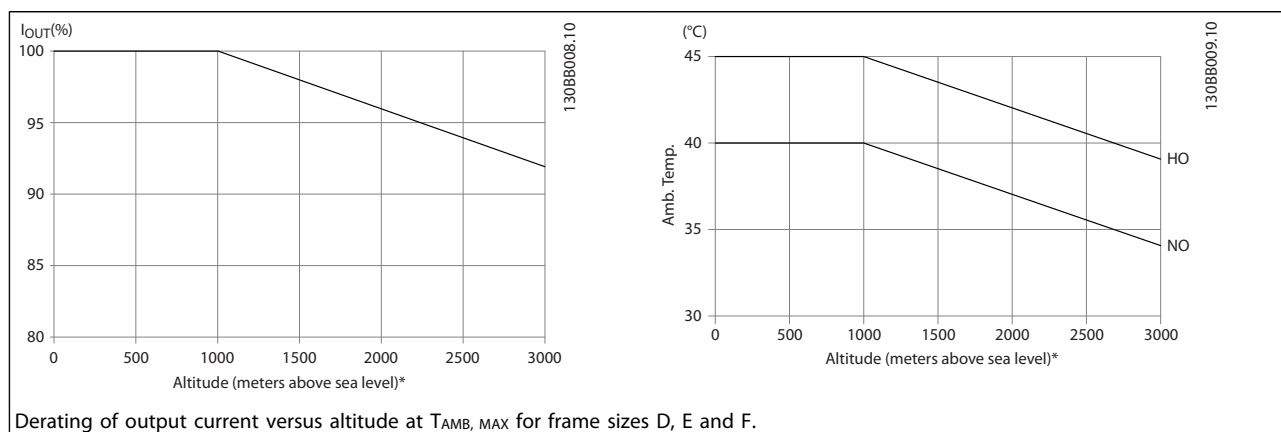

9 Troubleshooting

A warning or an alarm is signaled by the relevant LED on the front of the filter and indicated by a code on the display.

A warning remains active until its cause is no longer present. Under certain circumstances operation may still be continued. Warning messages are not critical for the filter operation and is often an indication that the filter has reached its maximum current capability. Even if filter compensation current is low, some higher order corrected harmonics might have reached the filter maximum capability resulting in an overload warning. Only critical warnings will, if not automatically resolved, generate an alarm.

In the event of an alarm, the active filter will have tripped. Alarms must be reset to restart operation once their cause has been rectified.

This may be done in four ways:

1. By using the [RESET] control button on the LCP.
2. Via a digital input with the "Reset" function.
3. Via serial communication/optional Serial communication bus.
4. By resetting automatically using the [Auto Reset] function. See *14-20 Reset Mode* in *6 How to Program*.

NOTE!

After a manual reset using the [RESET] button on the LCP, the [AUTO ON] or [HAND ON] button must be pressed to restart the unit.

If an alarm cannot be reset, the reason may be that its cause has not been rectified, or the alarm is trip-locked (see *Table 9.1*).

Alarms that are trip-locked offer additional protection, means that the line power supply must be switched off before the alarm can be reset. After being switched back on, the device is no longer blocked and may be reset as described above once the cause has been rectified.

Alarms that are not trip-locked can also be reset using the automatic reset function in *14-20 Reset Mode* (Warning: automatic wake-up is possible!)

If a warning and alarm is marked against a code in the table on the following page, this means that either a warning occurs before an alarm, or it can be specified whether it is a warning or an alarm that is to be displayed for a given fault.

No.	Description	Warning	Alarm/Trip	Alarm/Trip Lock	Parameter Reference
1	10 Volts low	X			
2	Live zero error	(X)	(X)		6-01
4	Line phase loss		X		
5	DC link voltage high	X			
6	DC link voltage low	X			
7	DC overvoltage	X	X		
8	DC undervoltage	X	X		
13	Overcurrent	X	X	X	
14	Ground fault	X	X	X	
15	Hardware mismatch		X	X	
16	Short Circuit		X	X	
17	Control word timeout	(X)	(X)		8-04
23	Internal Fan Fault	X			
24	External Fan Fault	X			14-53
29	Heatsink temp	X	X	X	
33	Inrush fault		X	X	
34	Serial communication bus fault	X	X		
35	Option fault	X	X		
38	Internal fault				

No.	Description	Warning	Alarm/Trip	Alarm/Trip Lock	Parameter Reference
39	Heatsink sensor		X	X	
40	Overload of Digital Output Terminal 27	(X)			5-00, 5-01
41	Overload of Digital Output Terminal 29	(X)			5-00, 5-02
46	Pwr. card supply		X	X	
47	24 V supply low	X	X	X	
48	1.8 V supply low		X	X	
65	Control Board Over-temperature	X	X	X	
66	Heat sink Temperature Low	X			
67	Option Configuration has Changed		X		
68	Safe Stop Activated		X ¹⁾		
69	Pwr. Card Temp		X	X	
70	Illegal FC configuration			X	
72	Dangerous Failure			X ¹⁾	
73	Safe Stop Auto Restart				
76	Power Unit Set-up	X			
79	Illegal PS config		X	X	
80	Drive Initialized to Default Value		X		
244	Heatsink temp	X	X	X	
245	Heatsink sensor		X	X	
246	Pwr.card supply		X	X	
247	Pwr.card temp		X	X	
248	Illegal PS config		X	X	
250	New spare part			X	
251	New type code		X	X	
300	Line Power Cont. fault		X		
301	SC Cont. Fault		X		
302	Cap. Overcurrent	X	X		
303	Cap. Earth Fault	X	X		
304	DC Overcurrent	X	X		
305	Line Power Freq. Limit		X		
308	Resistor temp	X		X	
309	Line Power Ground Fault	X	X		
311	Switch. Freq. Limit		X		
314	Auto CT Interrupt		X		
315	Auto CT Error		X		
316	CT Location Error		X		
317	CT Polarity Error		X		
318	CT Ratio Error		X		

Table 9.1 Alarm/Warning code list

A trip is the action when an alarm has appeared. The trip will stop the filter operation and can be reset by pressing the reset button or make a reset by a digital input (Par. 5-1* [1]). The origin event that caused an alarm cannot damage the filter or cause dangerous conditions. A trip lock is an action when an alarm occurs, which may cause damage to the device or connected parts. A trip lock situation can only be reset by power cycling.

LED indication	
Warning	yellow
Alarm	flashing red
Trip locked	yellow and red

Alarm Word and Extended Status Word					
Bit	Hex	Dec	Alarm Word	Warning Word	Extended Status Word
0	00000001	1	Line Power Cont. Fault	Reserved	Reserved
1	00000002	2	Heatsink Temp	Heatsink Temp	Auto CT Running
2	00000004	4	Ground Fault	Ground Fault	Reserved
3	00000008	8	Ctrl.Card Temp	Ctrl.Card Temp	Reserved
4	00000010	16	Ctrl. Word TO	Ctrl. Word TO	Reserved
5	00000020	32	Overcurrent	Overcurrent	Reserved
6	00000040	64	SC Cont. Fault	Reserved	Reserved
7	00000080	128	Cap. Overcurrent	Cap. Overcurrent	Reserved
8	00000100	256	Cap. Ground Fault	Cap. Ground Fault	Reserved
9	00000200	512	Inverter Overld.	Inverter Overld.	Reserved
10	00000400	1024	DC under Volt	DC undervolt	Reserved
11	00000800	2048	DC over volt	DC over volt	Reserved
12	00001000	4096	Short Circuit	DC Voltage Low	Reserved
13	00002000	8192	Inrush Fault	DC Voltage High	Reserved
14	00004000	16384	Line ph. Loss	Line ph. Loss	Reserved
15	00008000	32768	Auto CT Error	Reserved	Reserved
16	00010000	65536	Reserved	Reserved	Reserved
17	00020000	131072	Internal Fault	10V low	Password Time Lock
18	00040000	262144	DC Overcurrent	DC Overcurrent	Password Protection
19	00080000	524288	Resistor temp	Resistor temp	Reserved
20	00100000	1048576	Line Power Ground Fault	Line Power Ground Fault	Reserved
21	00200000	2097152	Switch. Freq. Limit	Reserved	Reserved
22	00400000	4194304	Serial communication bus Fault	Serial communication bus Fault	Reserved
23	00800000	8388608	24 V Supply Low	24V Supply Low	Reserved
24	01000000	16777216	CT Range	Reserved	Reserved
25	02000000	33554432	1.8V supply low	Reserved	Reserved
26	04000000	67108864	Reserved	Low Temp	Reserved
27	08000000	134217728	Auto CT Interrupt	Reserved	Reserved
28	10000000	268435456	Option Change	Reserved	Reserved
29	20000000	536870912	Unit Initialized	Unit Initialized	Reserved
30	40000000	1073741824	Safe Stop	Safe Stop	Reserved
31	80000000	2147483648	Line Power Freq. Limit	Extended Status Word	Reserved

Table 9.2 Description of Alarm Word, Warning Word and Extended Status Word

The alarm words, warning words and extended status words can be read out via serial bus or optional Serial communication bus for diagnosis. See also *16-90 Alarm Word*, *16-92 Warning Word* and *16-94 Ext. Status Word*. "Reserved" means that the bit is not guaranteed to be any particular value. Reserved bits should not be used for any purpose.

WARNING 1, 10 Volts low

The control card voltage is below 10 V from terminal 50. Remove some of the load from terminal 50, as the 10 V supply is overloaded. Max. 15 mA or minimum 590 Ω.

This condition can be caused by a short in a connected potentiometer or improper wiring of the potentiometer.

Troubleshooting: Remove the wiring from terminal 50. If the warning clears, the problem is with the customer wiring. If the warning does not clear, replace the control card.

WARNING/ALARM 2, Live zero error

This warning or alarm will only appear if programmed by the user in *6-01 Live Zero Timeout Function*. The signal on one of the analog inputs is less than 50% of the minimum value programmed for that input. This condition can be caused by broken wiring or faulty device sending the signal.

Troubleshooting

Check connections on all the analog input terminals. Control card terminals 53 and 54 for signals, terminal 55 common. MCB 101 terminals 11 and 12 for signals, terminal 10 common. MCB 109 terminals 1, 3, 5 for signals, terminals 2, 4, 6 common).

Check that the Adjustable frequency drive programming and switch settings match the analog signal type.

Perform Input Terminal Signal Test.

WARNING/ALARM 4, Mains phase loss

A phase is missing on the supply side, or the line voltage imbalance is too high. This message also appears for a fault in the input rectifier on the Adjustable frequency drive. Options are programmed at *14-12 Function at Mains Imbalance*.

Troubleshooting: Check the supply voltage and supply currents to the Adjustable frequency drive.

WARNING 5, DC link voltage high

The intermediate circuit voltage (DC) is higher than the high voltage warning limit. The limit is dependent on the Adjustable frequency drive voltage rating. The unit is still active.

WARNING 6, DC link voltage low

The intermediate circuit voltage (DC) is lower than the low voltage warning limit. The limit is dependent on the Adjustable frequency drive voltage rating. The unit is still active.

WARNING/ALARM 7, DC overvoltage

If the intermediate circuit voltage exceeds the limit, the Adjustable frequency drive trips after a time.

Troubleshooting

Connect a brake resistor

Extend the ramp time

Change the ramp type

Activate the functions in *2-10 Brake Function*

Increase *14-26 Trip Delay at Inverter Fault*

WARNING/ALARM 8, DC undervoltage

If the intermediate circuit voltage (DC link) drops below the under voltage limit, the Adjustable frequency drive checks if a 24V DC backup supply is connected. If no 24V DC backup supply is connected, the Adjustable frequency drive trips after a fixed time delay. The time delay varies with unit size.

Troubleshooting:

Check that the supply voltage matches the Adjustable frequency drive voltage.

Perform input voltage test

Perform soft charge circuit test

WARNING/ALARM 13, Overcurrent

The inverter peak current limit (approximately 200% of the rated current) is exceeded. The warning lasts about 1.5 secs., then the Adjustable frequency drive trips and issues an alarm. This fault may be caused by shock loading or fast acceleration with high inertia loads. If extended mechanical brake control is selected, trip can be reset externally.

Troubleshooting:

Remove power and check if the motor shaft can be turned.

Check that the motor size matches the Adjustable frequency drive.

Check parameters 1-20 through 1-25 for correct motor data.

ALARM 14, Ground fault

There is current from the output phases to ground, either in the cable between the Adjustable frequency drive and the motor or in the motor itself.

Troubleshooting:

Remove power to the Adjustable frequency drive and repair the ground fault.

Check for ground faults in the motor by measuring the resistance to ground of the motor leads and the motor with a megohmmeter.

ALARM 15, Hardware mismatch

A fitted option is not operational with the present control board hardware or software.

Record the value of the following parameters and contact your Danfoss supplier:

- 15-40 FC Type
- 15-41 Power Section
- 15-42 Voltage
- 15-43 Software Version
- 15-45 Actual Typecode String
- 15-49 SW ID Control Card
- 15-50 SW ID Power Card
- 15-60 Option Mounted
- 15-61 Option SW Version (for each option slot)

ALARM 16, Short circuit

There is short-circuiting in the motor or motor wiring.

Remove power to the Adjustable frequency drive and repair the short circuit.

WARNING/ALARM 17, Control word timeout

There is no communication to the Adjustable frequency drive.

The warning will only be active when 8-04 Control Word Timeout Function is NOT set to OFF.

If 8-04 Control Word Timeout Function is set to Stop and Trip, a warning appears and the Adjustable frequency drive ramps down until it stops then displays an alarm.

Troubleshooting:

- Check connections on the serial communication cable.
- Increase 8-03 Control Word Timeout Time
- Check the operation of the communication equipment.
- Verify a proper installation based on EMC requirements.

WARNING 23, Internal fan fault

The fan warning function is an extra protective function that checks if the fan is running/mounted. The fan warning can be disabled in 14-53 Fan Monitor ([0] Disabled).

For the D, E, and F Frame filters, the regulated voltage to the fans is monitored.

Troubleshooting:

- Check for proper fan operation.
- Cycle power to the Adjustable frequency drive and make sure that the fan operates briefly at start-up.
- Check the sensors on the heatsink and control card.

WARNING 24, External fan fault

The fan warning function is an extra protective function that checks if the fan is running/mounted. The fan warning can be disabled in 14-53 Fan Monitor ([0] Disabled).

Troubleshooting:

- Check for proper fan operation.
- Cycle power to the Adjustable frequency drive and make sure that the fan operates briefly at start-up.
- Check the sensors on the heatsink and control card.

ALARM 29, Heatsink temp

The maximum temperature of the heatsink has been exceeded. The temperature fault will not reset until the temperature falls below a defined heatsink temperature. The trip and reset points are different based on the Adjustable frequency drive power size.

Troubleshooting:

- Check for the following conditions.
 - Ambient temperature too high.
 - Motor cable too long.
 - Incorrect airflow clearance above and below the Adjustable frequency drive
 - Blocked airflow around the Adjustable frequency drive.
 - Damaged heatsink fan.
 - Dirty heatsink.

ALARM 33, Inrush fault

Too many power-ups have occurred within a short time period. Let the unit cool to operating temperature.

WARNING/ALARM 34, communication fault

The serial communication bus on the communication option card is not working.

WARNING/ALARM 35, Out of frequency range

This warning is active if the output frequency has reached the high limit (set in 4-53 Warning Speed High) or low limit (set in 4-52 Warning Speed Low). In Process Control, Closed-loop (1-00 Configuration Mode), this warning is displayed.

ALARM 38, Internal fault

When an internal fault occurs, a code number defined in the table below is displayed.

Troubleshooting

- Cycle power
- Check that the option is properly installed
- Check for loose or missing wiring

It may be necessary to contact your Danfoss supplier or service department. Note the code number for further troubleshooting directions.

No.	Text
0	Serial port cannot be initialized. Contact yourDanfoss supplier or DanfossService Department.
256-258	Power EEPROM data is defect or too old
512-519	Internal fault. Contact yourDanfoss supplier or Danfoss Service Department.
783	Parameter value outside of min/max limits
1024-1284	Internal fault. Contact your Danfoss supplier or the Danfoss Service Department.
1299	Option SW in slot A is too old
1300	Option SW in slot B is too old
1302	Option SW in slot C1 is too old
1315	Option SW in slot A is not supported (not allowed)
1316	Option SW in slot B is not supported (not allowed)
1318	Option SW in slot C1 is not supported (not allowed)
1379-2819	Internal fault. Contact yourDanfoss supplier or DanfossService Department.
2820	LCP stack overflow
2821	Serial port overflow
2822	USB port overflow
3072-5122	Parameter value is outside its limits
5123	Option in slot A: Hardware incompatible with control board hardware
5124	Option in slot B: Hardware incompatible with control board hardware
5125	Option in slot C0: Hardware incompatible with control board hardware
5126	Option in slot C1: Hardware incompatible with control board hardware
5376-6231	Internal fault. Contact yourDanfoss supplier or DanfossService Department.

ALARM 39, Heatsink sensor

No feedback from the heatsink temperature sensor.

The signal from the IGBT thermal sensor is not available on the power card. The problem could be on the power card, on the gate drive card, or the ribbon cable between the power card and gate drive card.

WARNING 40, Overload of digital output terminal 27

Check the load connected to terminal 27 or remove short-circuit connection. Check *5-00 Digital I/O Mode* and *5-01 Terminal 27 Mode*.

WARNING 41, Overload of digital output terminal 29

Check the load connected to terminal 29 or remove short-circuit connection. Check *5-00 Digital I/O Mode* and *5-02 Terminal 29 Mode*.

WARNING 42, Overload of digital output on X30/6 or overload of digital output on X30/7

For X30/6, check the load connected to X30/6 or remove short-circuit connection. Check *5-32 Term X30/6 Digi Out (MCB 101)*.

For X30/7, check the load connected to X30/7 or remove short-circuit connection. Check *5-33 Term X30/7 Digi Out (MCB 101)*.

ALARM 43, Ext. supply

MCB 113 Ext. Relay Option is mounted without ext. 24 V DC. Either connect an ext. 24 V DC supply or specify that no external supply is used via *14-80 Option Supplied by External 24VDC [0]*. A change in *14-80 Option Supplied by External 24VDC* requires a power cycle.

ALARM 46, Power card supply

The supply on the power card is out of range.

There are three power supplies generated by the switch mode power supply (SMPS) on the power card: 24V, 5V, +/- 18V. When powered with 24V DC with the MCB 107 option, only the 24V and 5V supplies are monitored. When powered with three-phase AC line voltage, all three supplied are monitored.

Troubleshooting

Check for a defective power card.

Check for a defective control card.

Check for a defective option card.

If a 24V DC power supply is used, verify proper supply power.

WARNING 47, 24V supply low

The 24 V DC is measured on the control card. The external 24V DC backup power supply may be overloaded; otherwise, contact your Danfoss supplier.

WARNING 48, 1.8V supply low

The 1.8V DC supply used on the control card is outside of allowable limits. The power supply is measured on the control card. Check for a defective control card. If an option card is present, check for an overvoltage condition.

WARNING 66, Heatsink temperature low

The Adjustable frequency drive is too cold to operate. This warning is based on the temperature sensor in the IGBT module.

Increase the ambient temperature of the unit. Also, a trickle amount of current can be supplied to the Adjustable frequency drive whenever the motor is stopped by setting *2-00 DC Hold/Preheat Current* at 5% and *1-80 Function at Stop*

ALARM 67, Option module configuration has changed

One or more options have either been added or removed since the last power-down. Check that the configuration change is intentional and reset the unit.

ALARM 68, Safe stop activated

Loss of the 24V DC signal on terminal 37 has caused the filter to trip. To resume normal operation, apply 24V DC to terminal 37 and reset the filter.

ALARM 69, Power card temperaturePower card temperature

The temperature sensor on the power card is either too hot or too cold.

Troubleshooting

- Check that the ambient operating temperature is within limits.
- Check for clogged filters.
- Check fan operation.
- Check the power card.

ALARM 70, Illegal FC configuration

The control card and power card are incompatible. Contact your supplier with the type code of the unit from the nameplate and the part numbers of the cards to check compatibility.

WARNING 73, Safe stop auto restart

Safe stopped. Note that with automatic restart enabled, the motor may start when the fault is cleared.

77 WARNING, Reduced power mode

This warning indicates that the Adjustable frequency drive is operating in reduced power mode (i.e., less than the allowed number of inverter sections). This warning will be generated on power cycle when the Adjustable frequency drive is set to run with fewer inverters and will remain on.

ALARM 79, Illegal power section configuration

The scaling card is the incorrect part number or not installed. Also MK102 connector on the power card could not be installed.

ALARM 80, Unit initialized to default value

Parameter settings are initialized to default settings after a manual reset. Reset the unit to clear the alarm.

ALARM 244, Heatsink temperature

This alarm is only for F Frame adjustable frequency drives. It is equivalent to Alarm 29. The report value in the alarm log indicates which power module generated the alarm:

ALARM 245, Heatsink sensor

This alarm is only for F Frame adjustable frequency drives. It is equivalent to Alarm 39. The report value in the alarm log indicates which power module generated the alarm.

- 1 = left most inverter module.
- 2 = middle inverter module in F2 or F4 Adjustable frequency drive.
- 2 = right inverter module in F1 or F3 Adjustable frequency drive.

3 = right inverter module in F2 or F4 Adjustable frequency drive.

5 = rectifier module.

ALARM 246, Power card supply

This alarm is only for F Frame Adjustable frequency drive. It is equivalent to Alarm 46. The report value in the alarm log indicates which power module generated the alarm.

- 1 = left most inverter module.
- 2 = middle inverter module in F2 or F4 Adjustable frequency drive.
- 2 = right inverter module in F1 or F3 Adjustable frequency drive.
- 3 = right inverter module in F2 or F4 Adjustable frequency drive.
- 5 = rectifier module.

ALARM 69, Power card temperaturePower card temperature

This alarm is only for F Frame Adjustable frequency drive. It is equivalent to Alarm 69. The report value in the alarm log indicates which power module generated the alarm.

- 1 = left most inverter module.
- 2 = middle inverter module in F2 or F4 Adjustable frequency drive.
- 2 = right inverter module in F1 or F3 Adjustable frequency drive.
- 3 = right inverter module in F2 or F4 Adjustable frequency drive.
- 5 = rectifier module.

ALARM 248, Illegal power section configuration

This alarm is only for F Frame adjustable frequency drives. It is equivalent to Alarm 79. The report value in the alarm log indicates which power module generated the alarm:

- 1 = left most inverter module.
- 2 = middle inverter module in F2 or F4 Adjustable frequency drive.
- 2 = right inverter module in F1 or F3 Adjustable frequency drive.
- 3 = right inverter module in F2 or F4 Adjustable frequency drive.
- 5 = rectifier module.

WARNING 249, Rect. low temperature
IGBT sensor fault (highpower units only).

WARNING 250, New spare part

A component in the Adjustable frequency drive has been replaced. Reset the Adjustable frequency drive for normal operation.

WARNING 251, New type code

The power card or other components have been replaced and the type code changed. Reset to remove the warning and resume normal operation.

ALARM 300, Mains cont. fault

Line power contactor fault is displayed when the feedback signal indicates that the contactor is not in the expected state, i.e., either the contactor could not be closed or could not be opened, or that the feedback signal itself is wrong.

Troubleshooting:
Control and feedback wiring check

Verify that the control and feedback wiring is correct and that the electrical connections are tight. The 24 VDC output of the control card is taken from terminal 12, and the contactor feedback comes back to terminal 32. The contactor is energized from a control transformer through the power card relay. Perform a visual inspection to verify there is no physical damage to the wire insulation. This should be done for the control and for the feedback wiring. Perform a continuity check to test for wire breakage.

Perform the Control Card Digital Inputs/Outputs Test ().

Contactor test

Perform a continuity test of the contactor between the input terminal and output terminals. If continuity is detected, than the contactor fuse must be replaced. There should also be no continuity between any two test points of the three phases for either the input or the output side.

Loss of line power

A loss of AC line voltage will cause the contactor to open. Check the line power supply and consider employing auto reset.

Other

If none of the above tests have identified the problem, replace the power card.

ALARM 301, SC cont. fault

Soft charge contactor fault results when the feedback signal indicates that the contactor is not in the expected state, that is, either the contactor could not be closed or could not be opened, or that the feedback signal itself is wrong.

Update to software versions 1.7 or later.

Troubleshooting:

Perform tests as listed in Alarm 300, main contactor tests.

WARNING/ALARM 302, Cap. overcurrent

Excessive current was detected through the AC capacitors of the LCL filter.

See for current trip points.

Troubleshooting

- Check that the nominal voltage parameter (300-10) is set correctly. If the nominal voltage parameter is set to Auto, change this parameter to nominal voltage of the installation.
- Check that the CT parameter placement (parameter 300-26) corresponds to the installation
- Perform the Line Power Resonance Test ()

WARNING/ALARM 303, Car. earth fault

A ground fault was detected in the LCL filter AC capacitor currents. The summed currents in the LCL filter CTs exceeds the power unit dependent (PUD) level.

Troubleshooting:

- Turn off the filter
- Measure the resistance to ground of the LCL filter components leads with a megohmmeter to check for ground faults
- Perform AC capacitors and current transducers test ().
- Check that the connectors on current transducers and on the AFC card are pinned properly
- Check AC capacitors current transducers cables
- Replace the AFC card

WARNING/ALARM 304, DC overcurrent

Excessive current through the DC link capacitor bank was detected in the IGBT current sensors.

Troubleshooting

- Check the electrical fuses and ensure that all three line phases are powered
- Check that the CT parameter placement (parameter 300-26) corresponds to the installation
- Perform the Line Power Resonance Test ()

ALARM 305, Mains. freq. limit

The line power frequency was outside the limits (50 Hz–60 Hz) +/-10%. Verify that the line power frequency is within product specification. The alarm may also indicate loss of line power for 1 - 3 electrical cycles.

The active filter must synchronize to the AC line voltage in order to regulate the DC link voltage and inject compensating current. The active filter utilizes a phase-locked loop (PLL) to track the AC line voltage frequency.

When the active filter starts, the PLL uses the LCL filter AC capacitor currents from the current transducers to initialize for a period of 200 ms. After the PLL initialization period, the active filter inverter will then start switching, the line power estimated voltage is used instead of the capacitor currents as input to the PLL. The PLL is not tolerant of incorrect wiring or placement of the AC capacitor current transducers.

Troubleshooting:

- Turn off the filter
- Measure the resistance to ground of the LCL filter components leads with a megohmmeter to check for ground faults
- Perform AC capacitors and current transducers test (Section 6).
- Check that the connectors on current transducers and on the AFC card are pinned properly
- Check AC capacitors current transducers cables
- Replace the AFC card
- Automatic switching between the grid and a generator based on certain events can cause line power loss leading to this alarm. Use auto reset if this is the cause.

ALARM 306, Compensation limit

The compensation current exceeds unit capability. Unit is running at full compensation.

Warning 306 is informational in nature, and does not indicate a malfunction.

WARNING/ALARM 308, Resistor temp

Excessive resistor heatsink temperature detected.

A temperature feedback is implemented using an NTC thermistor mounted on the damping resistor heatsink. The temperature is calculated and compared to a power unit dependent (PUD) alarm level.

Warning 308 is displayed when the PUD warning level is reached. This indicates the resistor temperature is close to the alarm level.

Troubleshooting:

Verify if:

- Ambient temperature is too high
- Incorrect clearance above and below the unit
- Dirty heatsink
- Blocked air flow around the unit
- Damaged heatsink fan

WARNING/ALARM 309, Mains earth fault

A ground fault was detected, measured by the CT line power currents.

The sum current from three line power CTs is too high. The ground fault must be detected at every sample during a period of 400ms, for Alarm 309 to be reported.

Troubleshooting:

- Check the installation line power CTs and wiring
- Replace the AFC card

ALARM 310, RTDC buffer full

Contact supplier.

ALARM 311, Switch freq. limit

The average switching frequency of the unit exceeded the limit.

If the actual switching frequency exceeds 6 kHz for 10 electrical cycles, Alarm 311 is reported.

Service parameter P98-21 displays the actual switching frequency. NOTE: Do not change any service parameters unless directed to do so in this service manual.

Troubleshooting

Perform the Line Power Resonance Test ()

ALARM 312, CT range

Current transformer measurement limitation was detected. Verify that the CTs used are of an appropriate ratio.

ALARM 314, Auto CT interrupt

Auto CT detection was interrupted by the user.

ALARM 315, Auto CT error

An error was detected while performing auto CT detection.

Auto CT detection does not work under the following conditions: if any sum current transformers are installed, when the active filter is supplied through a step up or step down transformers, or when the filter is <10% of the CT primary. Program the CT parameters manually if auto CT detection fails.

WARNING 316, CT location error

The auto CT function could not determine the correct locations of the CTs.

Program the CT parameters manually if auto CT detection fails.

WARNING 317, CT polarity error

The auto CT function could not determine the correct polarity of the CTs.

Program the CT parameters manually if auto CT detection fails.

WARNING 318, CT ratio error

The auto CT function could not determine the correct primary rating of the CTs.

Program the CT parameters manually if auto CT detection fails.



www.danfoss.com/drives

Danfoss shall not be responsible for any errors in catalogs, brochures or other printed material. Danfoss reserves the right to alter its products at any time without notice, provided that alterations to products already on order shall not require material changes in specifications previously agreed upon by Danfoss and the Purchaser. All trademarks in this material are property of the respective companies. Danfoss and the Danfoss logotype are trademarks of Danfoss A/S. All rights reserved.

Danfoss Drives

4401 N. Bell School Rd.
Loves Park IL 61111 USA
Phone: 1-800-432-6367
1-815-639-8600
Fax: 1-815-639-8000
www.danfossdrives.com

Danfoss Drives

8800 W. Bradley Rd.
Milwaukee, WI 53224 USA
Phone: 1-800-621-8806
1-414-355-8800
Fax: 1-414-355-6117
www.danfossdrives.com

