

## ■ High voltage warning



The voltage of the frequency converter is dangerous whenever the equipment is connected to mains. Incorrect installation of the motor or frequency converter may cause damage to the equipment, serious injury or death. Comply with the instructions in this manual, as well as national and local rules and safety regulations. Touching the electrical parts may be fatal - even after the equipment has been disconnected from mains: Wait at least 4 minutes for current dissipate.



### NB!

It is the responsibility of the user or installer to ensure correct earthing and protection in accordance with national and local standards.

## ■ These rules concern your safety

1. The frequency converter must be disconnected from the mains if repair work is to be carried out. Check that the mains supply has been disconnected and that the prescribed time has passed before removing motor and mains plugs.
  2. The [STOP/RESET] key on the control panel of the frequency converter does not disconnect the equipment from mains and is thus not to be used as a safety switch.
  3. The unit must be properly connected to the earth, the user must be protected against the supply voltage and the motor must be protected against overloading pursuant to prevailing national and local regulations.
  4. The earth leakage currents are higher than 3.5 mA.
  5. Protection against motor overload is not included in the factory setting. If this function is required, set parameter 128 *Motor thermal protection* to data value *ETR trip* or data value *ETR warning*. For the North American market: The ETR functions provide overload protection of the motor, class 20, in accordance with NEC.
  6. Do not remove the plugs for the motor - and mains supply while the frequency converter is connected to mains. Check that the mains supply has been disconnected and that the prescribed time has passed before removing motor and mains plugs.
7. Note that the frequency converter has more voltage inputs than L1, L2 and L3 when the DC bus terminals are used. Check that all voltage inputs are disconnected and that the prescribed time has passed before repair work is commenced.

## ■ Warning against unintended start

1. The motor can be brought to a stop by means of digital commands, bus commands, references or a local stop, while the frequency converter is connected to mains. If personal safety considerations make it necessary to ensure that no unintended start occurs, these stop functions are not sufficient.
2. While parameters are being changed, the motor may start. Consequently, the stop key [STOP/RESET] must always be activated, following which data can be modified.
3. A motor that has been stopped may start if faults occur in the electronics of the frequency converter, or if a temporary overload or a fault in the supply mains or the motor connection ceases.

## ■ Motor coils

By fitting the motor coil module between the frequency converter and the motor it is possible to use up to 200 metres of unscreened/unarmoured motor cable or 100 metres of screened/armoured motor cable. The motor coil module has an enclosure of IP 20 and can be installed side-by-side.



### NB!

To have long motor cables and still comply with EN55011-1A, motor coil and EMC filter for long motor cables are needed.



### NB!

To comply with EN55011-1A the EMC filter for long motor cables can only be fitted to a VLT 2800 with integral 1A filter (R1 option).

See also the section EMC Emission.

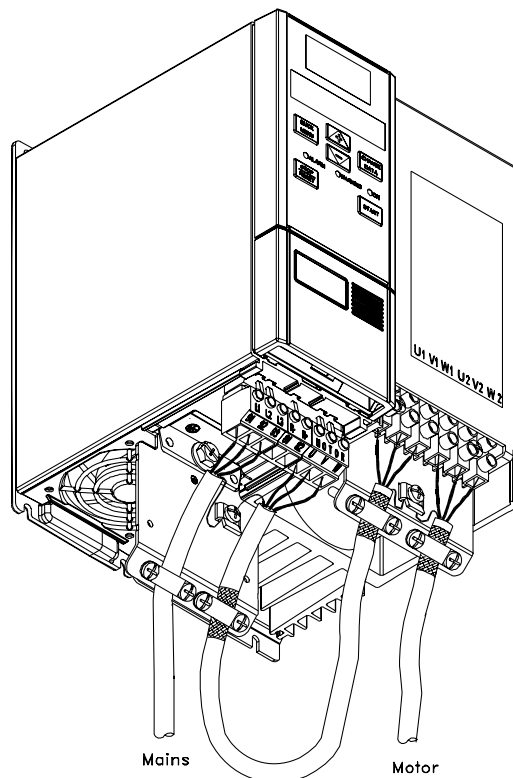

### Technical data for VLT 2803-2875 Motor coils

Max. cable length (unscreened/unarmoured) <sup>1)</sup>	200 m
Max. cable length (screened/armoured) <sup>1)</sup>	100 m
Enclosure	IP 20
Max. rated current <sup>1)</sup>	16 A
Max. voltage <sup>1)</sup>	480 V AC
Min. distance between VLT and motor coil	Side-by-side
Min. distance above and below motor coil	100 mm
Mounting	Vertical mounting only
Dimensions H x W x D (mm)	200 x 90 x 152
Weight	3.8 kg

<sup>1)</sup> Parameter 411 *Switching frequency* = 4500 Hz.

## ■ RFI 1B filter

All frequency converters will cause electromagnetic noise in the mains supply when they are operating. An RFI (Radio Frequency Interference) filter will reduce the electromagnetic noise in the mains supply. Without an RFI filter there is a risk that a frequency converter will disrupt other electrical components that are connected to the mains and might thus cause operating disruption.

By fitting an RFI 1B filter module between the mains supply and the VLT 2800, the VLT 2800 complies with the EMC norm EN 55011-1B.



### NB!

To comply with EN 55011-1B the RFI 1B filter module must be fitted together with a VLT 2800 with integral 1A RFI filter.

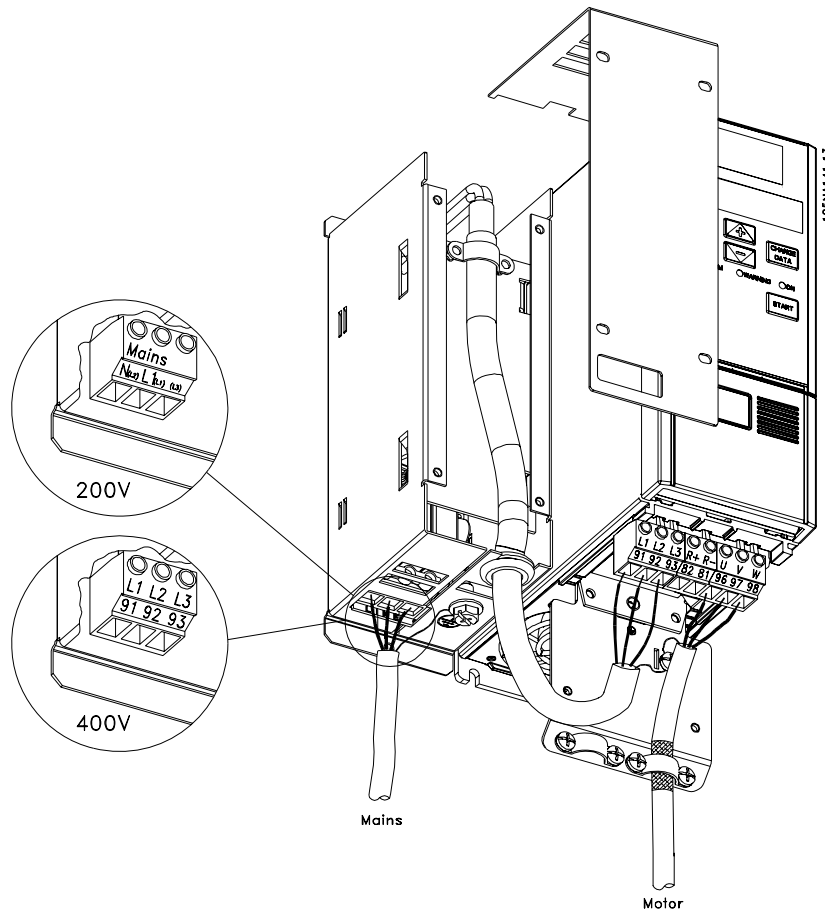

VLT 2800 Motorcoil, RFI 1B filter, RFI 1 B/LC filter

Technical data for VLT 2803–2875 RFI 1B filter	
Max. cable length (screened/armoured) 200-240 V	100 m (At 1A: 100 m)
Max. cable length (screened/armoured) 380-480 V	25 m (At 1A: 50 m)
Enclosure	IP 20
Max. rated current	16 A
Max. Voltage	480 V AC
Max. voltage to earth	300 V AC
Min. distance between VLT and RFI 1B filter	Side-by-Side
Min. distance above and below RFI 1B filter	100 mm
Mounting	Vertical mounting only
Dimensions H x W x D (mm)	200 x 60 x 87
Weight	0.9 kg

## ■ RFI 1B/LC filter



**NB!**

To comply with EN 55011-1B the RFI 1B filter module must be fitted to a VLT 2800 with integral 1A RFI filter.



**NB!**

The 1B/LC filter is not suitable for 200 V devices due to the high I<sub>Ø</sub> input current.

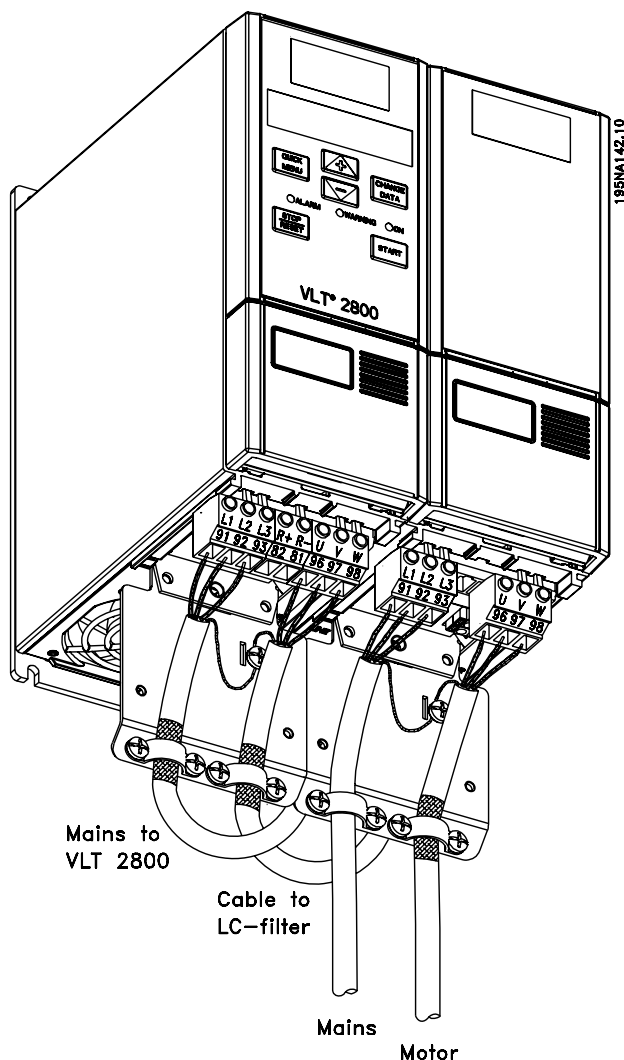

### Technical data for VLT 2803–2875 RFI 1B/LC filter

Max. cable length (screened/armoured) 380-480 V	25 m (At 1A: 50 m)
Enclosure	IP 20
Max. rated current	4.0 (Order no.: 195N3100); 9.1 (Order no.: 195N3101)
Max. voltage	480 V AC
Max. voltage to earth	300 V AC
Min. distance between VLT and RFI 1B/LC filter	Side-by-Side
Min. distance above and below RFI 1B/LC filter	100 mm
Mounting	Vertical mounting only
Dimensions 195N3100 4.0 A H x W x D (mm)	200 x 75 x 168
Dimensions 195N3101 9.1 A H x W x D (mm)	267.5 x 90 x 168
Weight 195N3100 4.0 A	2.4 kg
Weight 195N3101 9.1 A	4.0 kg

## ■ RFI 1B/LC filter

The RFI 1B/LC filter contains both an RFI module that complies with EN 55011-1B and an LC filter that reduces the acoustic noise.

### LC filter

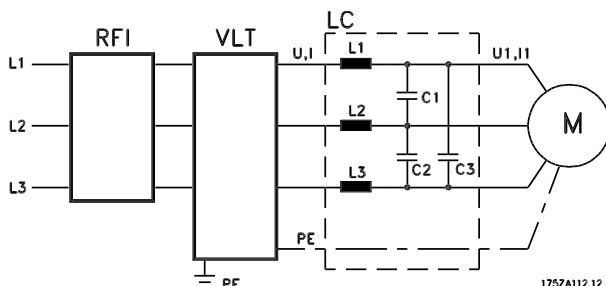

When a motor is controlled by a frequency converter, at times you will be able to hear the acoustic noise from the motor. The noise, which is caused by the design of the motor, is generated every time one of the inverter contacts in the frequency converter is activated. The frequency of the acoustic noise therefore corresponds to the frequency converter's connection frequency.

The filter reduces the voltage's  $du/dt$ , the peak voltage  $U_{peak}$  and ripple current  $\Delta I$  to the motor, so that the current and voltage are almost sine-shaped. The acoustic motor noise is thus reduced to a minimum.

Because of the ripple current in the coils some noise will be emitted by the coils. This problem can be solved completely by fitting the filter inside a cabinet or equivalent.

Danfoss can supply an LC filter for the VLT series 2800, which muffles the acoustic motor noise. Before the filters are put into use you must ensure that:

- rated current is observed
- mains voltage is 200-480 V
- parameter 412 *Variable switching frequency* is set to *LC filter attached* [3]
- output frequency is max. 120 Hz

See drawing on the next page.

## Installation of thermistor (PTC)

The RFI 1B/LC filter has an integral thermistor (PTC), which is activated if an overtemperature arises. The frequency converter can be programmed to stop the motor and activate an alarm via a relay output or a digital output if the thermistor is activated.

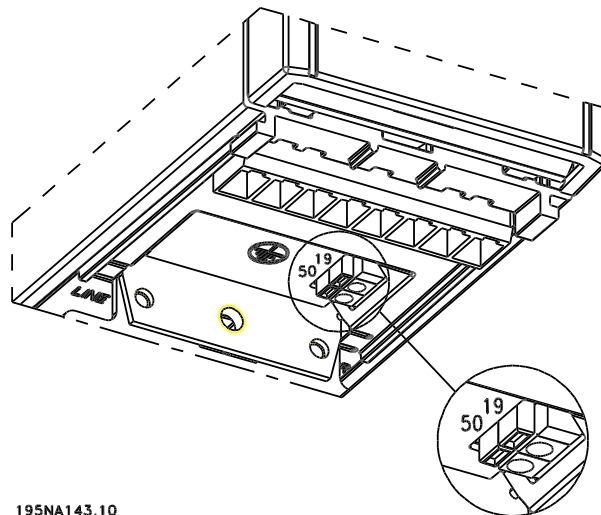

The thermistor must be connected between terminal 50 (+10V) and one of the digital inputs 18, 19, 27 and 29.

In parameter 128 *Motor thermal protection*, *Thermistor warning* [1] or *Thermistor trip* [2] are selected

The thermistor is connected as follows:

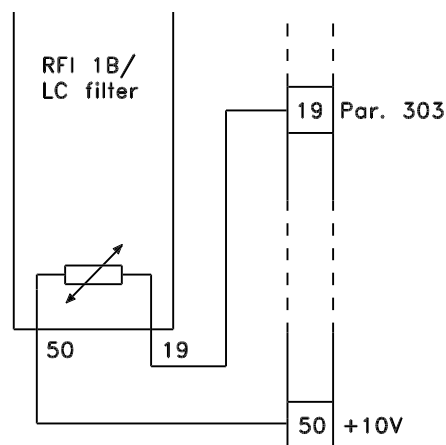

VLT 2800 Motorcoil, RFI 1B filter, RFI 1 B/LC filter

## ■ LC filter modules

When the speed of a motor is controlled by a frequency converter, resonance noise from the motor will occur occasionally. This is due to the construction of the motor and the noise occurs whenever one of the inverter switches of the frequency converter is activated. The frequency of the resonance will therefore correspond to the switching frequency.

The filter reduces the voltage rise time  $dU/dt$ , the peak voltage  $U_{peak}$  and the ripple current  $\Delta I$  to the motor. So the current and the voltage are near sinusoidal. That reduces the acoustic motor noise to a minimum.

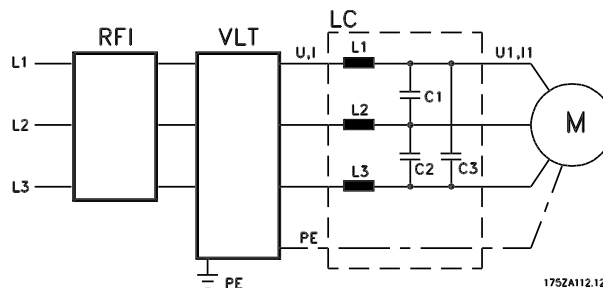

Because of the ripple current in the coils there will be some noise from the coils. However, if the filter is built into a cabinet or the like the coil noise will be no problem.

For the VLT 2800 Series, Danfoss can offer an LC filter which damps the acoustic motor noise.

To use the filters properly, it must be ensured that:

- they fit the VLT frequency converter
- the current ratings are observed
- the mains supply is 200-480 V
- par. 412 *Output frequency dependent switching* is set to *LC-filter fitted* [3]
- the output frequency is max. 120 Hz

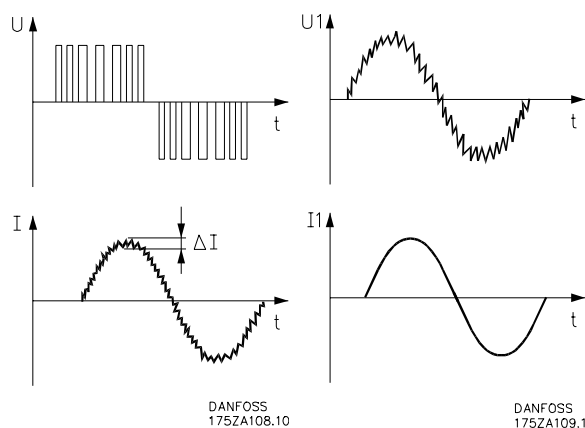

### NB!

The application of Automatic Motor Tuning (AMT) is limited, if an LC filter is installed.



### NB!

Par. 411 *Switching frequency* will be set to 4.5 kHz after selecting *LC-filter fitted* [3] in par. 412 *Output frequency dependent switching*.

## ■ Code Nos. for LC filter modules

### Mains supply for 3 x 200-240 V

LC filter for VLT type	Rated current at 230 V	Max. output frequency	Code no.
2803-2805	4.0 A	120 Hz	195N3100
2807-2815	9.1 A	120 Hz	195N3101

### Mains supply for 3 x 380-480 V

LC filter for VLT type	Rated current at 400 V	Max. output frequency	Code no.
2805-2815	4.0 A	120 Hz	195N3100
2822-2840	9.1 A	120 Hz	195N3101