

Contents

1. Safety and precautions	3
Safety Instructions	3
Avoid unintended Start	3
General Warning	4
2. Introduction	5
General Description	5
3. Supported Configuration	9
Introduction	9
Fixed Speed Pump Configuration	9
Master-Follower Configuration	10
Mixed Pump Configuration	10
Unequal Size Pump Configuration	11
Mixed Pump Configuration with Alternation	12
Soft Starters	14
4. Configuring the System	15
Introduction	15
Defining the Hardware Configuration	15
Additional configuration for Multiple Drives	15
Closed Loop Control	16
Staging /Destaging of variable speed pumps based on Drive Speed	16
Staging Destaging of fixed speed pumps based on Pressure Feedback	17
5. Running the Extended Cascade controller	19
Introduction	19
6. Cascade Controller Features	21
Pump Status and Control	21
Manual Pump Control	21
Runtime Balancing	22
Pump Spin for unused pumps	22
Total lifetime hours	23
Alternation of the Lead Pump	23
Staging / Destaging in Mixed Pump Configurations	23
Override Staging /Destaging	24
Minimum Speed Destaging	24
Fixed speed only operation	24
7. How to Programme	27

Extended Cascade Controller Parameters	27
Cascade CTL Option, 27-**	27
Control & Status, 27-0*	27
Configuration, 27-1*	28
Bandwidth Settings, 27-2*	30
Staging Speed, 27-3*	32
Staging Settings, 27-4*	33
Alternation Settings, 27-5*	36
Connections, 27-7*	37
27-9* Readouts	38
Index	41

1. Safety and precautions

1.1.1. High Voltage Warning



The voltage of the frequency converter and the MCO 101 option card is dangerous whenever it is connected to mains. Incorrect installation of the motor or frequency converter may cause damage to the equipment, serious injury or death. Consequently, it is essential to comply with the instructions in this manual as well as local and national rules and safety regulations.

1.1.2. Safety Instructions



- Make sure the frequency converter is properly connected to earth.
- Do not remove mains connections, motor connections or other power connections while the frequency converter is connected to power.
- Protect users against supply voltage.
- Protect the motor against overloading according to national and local regulations.
- The earth leakage current exceeds 3.5 mA.
- The [OFF] key is not a safety switch. It does not disconnect the frequency converter from mains.

1.1.3. Avoid unintended Start

While the frequency converter is connected to mains, the motor can be started/stopped using digital commands, bus commands, references or via the Local Control Panel.

- Disconnect the frequency converter and the MCO 101 option card from mains whenever personal safety considerations make it necessary to avoid unintended start of any motors.
- To avoid unintended start, always activate the [OFF] key before changing parameters.

Extended Cascade Controller Option for
VLT AQUA Drive FC 200
 Operating Instructions
 Software version: 01.00

These Operating Instructions can be used with all Extended Cascade Controller options with software version 01.00.

When reading through this Operating Instructions, you will come across various symbols that require special attention.

The symbols used are the following:



Indicates a general warning.



NB!

Indicates something to be noted by the reader.



Indicates a high-voltage warning.

1.1.4. General Warning



Warning:

Touching the electrical parts may be fatal - even after the equipment has been disconnected from mains.

Also make sure that other voltage inputs have been disconnected, (linkage of DC intermediate circuit), as well as the motor connection for kinetic back-up.

Before touching any potentially live parts of the VLT AQUA Drive FC 200, wait at least as follows:

200 - 240 V, 0.25 - 3.7 kW: wait at least 4 minutes.

200 - 240 V, 5.5 - 45 kW: wait at least 15 minutes.

380 - 480 V, 0.37 - 7.5 kW: wait at least 4 minutes.

380 - 480 V, 11 - 90 kW, wait at least 15 minutes.

Shorter time is allowed only if indicated on the nameplate for the specific unit.

2. Introduction

2

The Extended Cascade Controller option provides the capability to control multiple pumps configured in parallel in a way that makes them appear as a single larger pump.

Using the Extended Cascade Controller individual pumps are automatically turned on (staged) and turned off (destaged) as needed to satisfy the required system output for flow or pressure. The speed of pumps connected to VLT AQUA Drives is also controlled to provide a continuous range of system output.

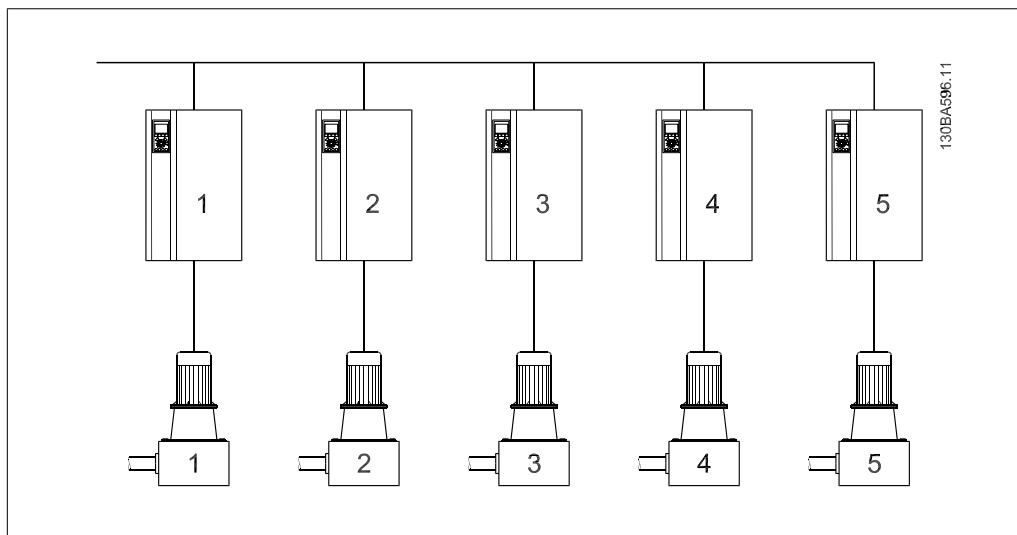

The Extended Cascade Controller is an optional hardware and software component that can be added to the VLT AQUA Drive. It consists of an option board containing 3 relays that is installed in the B option location on the Drive. Once the option is installed the parameters needed to support the Extended Cascade Controller functions will be available through the control panel in the 27-**-** parameter group. The Extended Cascade Controller offers more functionality than the Basic Cascade Controller. It can be used to extend the Basic Cascade with 3 relays.

While the Cascade controller is designed for pumping applications, and this document describes the cascade controller in these terms, it is also possible to use the Extended Cascade Controller for any application requiring multiple motors configured in parallel.

2.1.1. General Description

The Extended Cascade Controller software runs from a single VLT AQUA Drive with the Extended Cascade Controller option card installed. This Drive is referred to as the Master Drive. It controls a set of pumps each controlled by a Danfoss VLT Drive or connected directly to mains through a contactor or through a soft starter.

Each additional VLT Drive in the system is referred to as a Follower Drive. These Drives do not need the Extended Cascade Controller option card installed. They are operated in open loop mode and receive their speed reference from the Master Drive. The pumps connected to these Drives are referred to as Variable Speed pumps.

Each additional pump connected to mains through a contactor or through a soft starter is referred to as a Fixed Speed pump.

Each pump, variable speed or fixed speed, is controlled by a relay in the Master Drive. The VLT AQUA Drive with the Extended Cascade Controller option card installed has five relays available for controlling pumps. 2 relays standard in the drive and additional 3 relays on the option card MCO 101.

The Extended Cascade Controller is capable of controlling a mix of variable speed and fixed speed pumps. Possible configurations are described in more detail in the next section. For simplicity of description within this manual, Pressure and Flow will be used to describe the variable output of the set of pumps controlled by the cascade controller.

2.1.2. Extended Cascade Control MCO 101

The MCO 101 option includes 3 pieces of change over contacts and can be fitted into option slot B.

Electrical Data:

Max terminal load (AC)	240 V AC 2A
Max terminal load (DC)	24 V DC 1 A
Min terminal load (DC)	5 V 10 mA
Max switching rate at rated load/min load	6 min ⁻¹ /20 sec ⁻¹

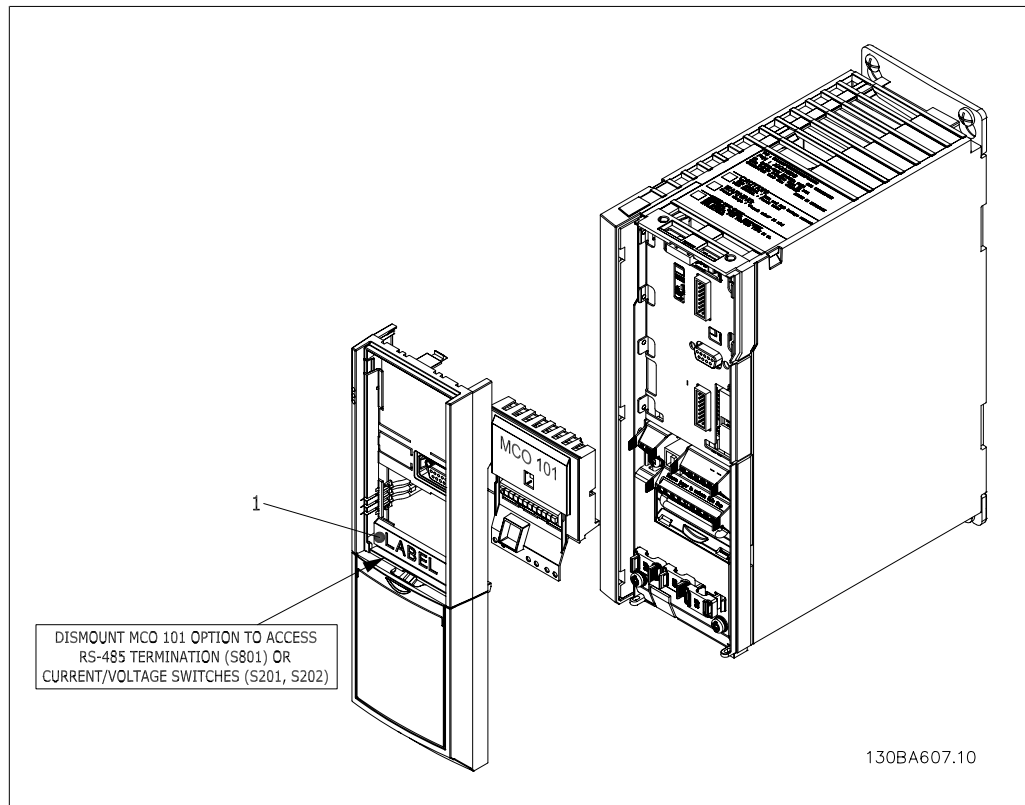

Warning Dual supply



NB!

The label **MUST** be placed on the LCP frame as shown (UL approved).

How to add the MCO 101 option:

- The power to the frequency converter must be disconnected.
- The power to the live part connections on relay terminals must be disconnected.
- Remove the LCP, the terminal cover and the cradle from the FC 202.
- Fit the MCO 101 option in slot B.
- Connect the control cables and relief the cables by the enclosed cable strips.
- Various systems must not be mixed.
- Fit the extended cradle and terminal cover.
- Replace the LCP
- Connect power to the frequency converter.

Wiring the Terminals

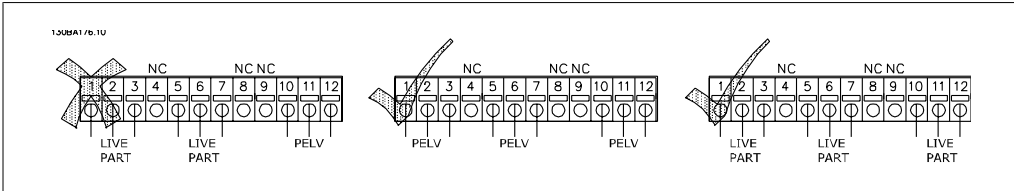
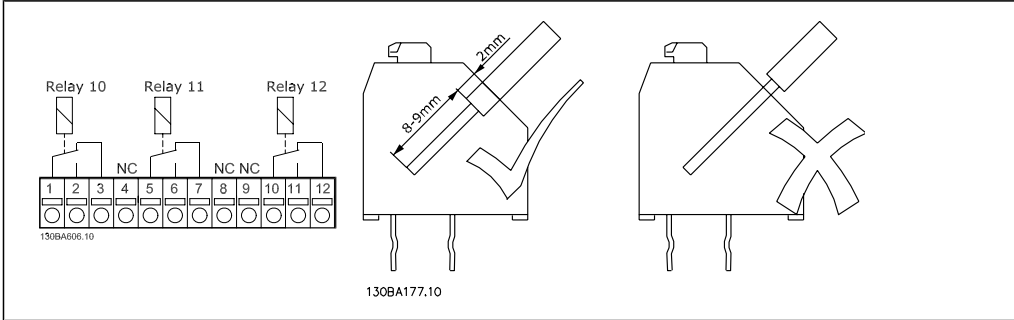

Do not combine low voltage parts and PELV systems.

2

3. Supported Configuration

3.1.1. Introduction

The Extended Cascade Controller supports a variety of different pump and Drive configurations. All of these configurations must have at least one variable speed pump, controlled by a VLT AQUA Drive, with the Extended Cascade Controller option card installed. They must also have from one to five additional pumps each connected to either a Danfoss VLT Drive or to mains through a contactor or soft starter.

3

3.1.2. Fixed Speed Pump Configuration

In this configuration a single Drive controls one variable speed pump and up to 5 fixed speed pumps. The fixed speed pumps are staged and destaged as needed through contactors direct online. The single pump connected to the Drive provides the finer level of control needed between the stages.

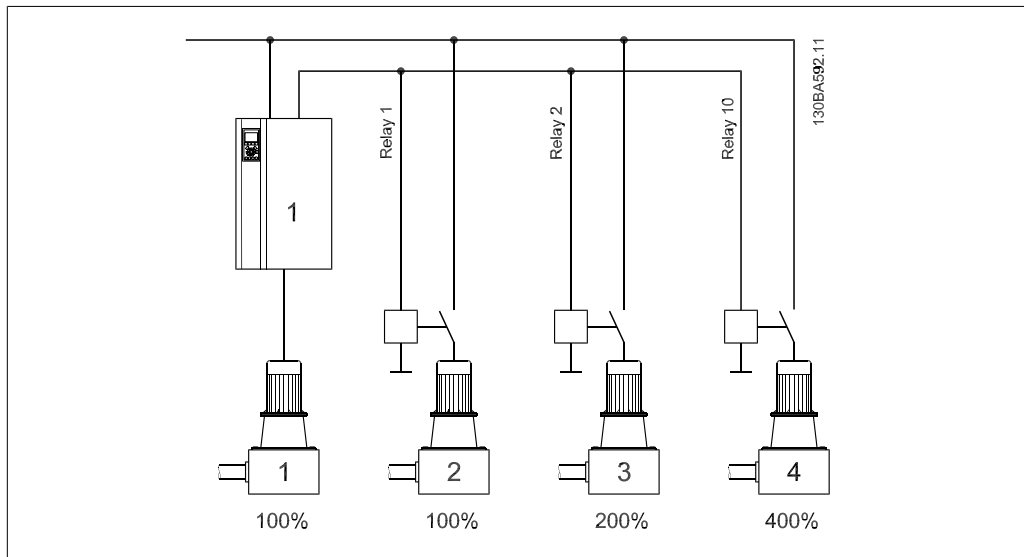

Illustration 3.1: Example

For this configuration relay selections in Group 27-7* "Connections" are as follows:

- 27-70 RELAY 1 → [73] Pump 2 to Mains
- 27-71 RELAY 2 → [74] Pump 3 to Mains
- 27-72 RELAY 10 → [75] Pump 4 to Mains
- 27-73 RELAY 11 → [0] Standard Relay
- 27-74 RELAY 12 → [0] Standard Relay

The Fixed Speed Pump configuration provides a cost effective method for controlling up to 6 pumps. It is able to control system output by controlling the number of running pumps as well as the speed of the single variable speed pump. It will however produce wider pressure fluctuations during staging/destaging transitions and it may be less energy efficient than the Master-Follower configurations.

3.1.3. Master-Follower Configuration

In this configuration each pump is controlled by a Drive. All of the pumps and Drives must be of the same size. Staging and destaging decisions are made based on the speed of the Drives as well as the feedback sensor. Up to 6 pumps with Drives can be part of this configuration.

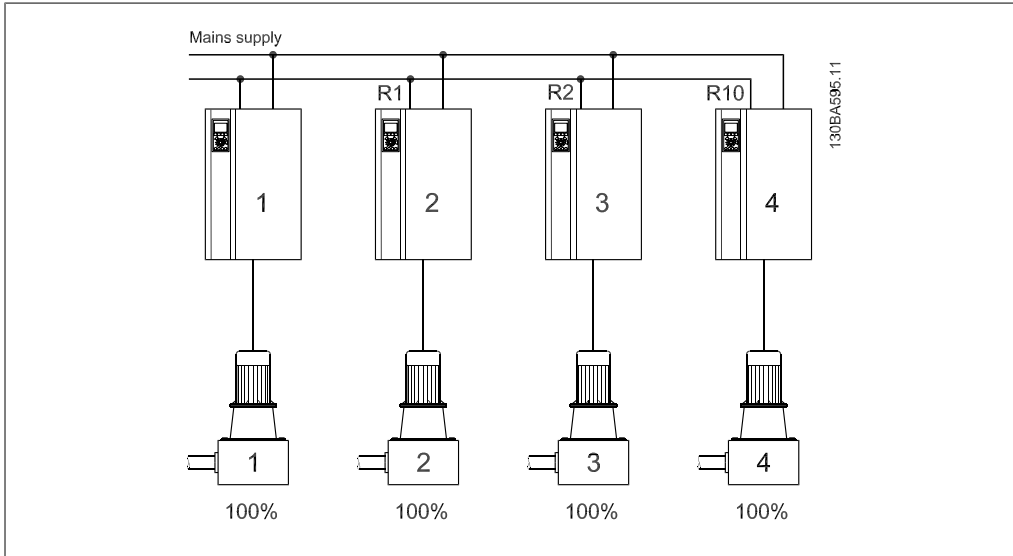

Illustration 3.2: Example

For this configuration relay selections in Group 27-7* "Connections" are as follows:

- 27-70 RELAY 1 → [1] Drive 2 Enable
- 27-71 RELAY 2 → [2] Drive 3 Enable
- 27-72 RELAY 10 → [3] Drive 4 Enable
- 27-73 RELAY 11 → [0] Standard Relay
- 27-74 RELAY 12 → [0] Standard Relay

The master follower configuration provides the gentlest transition from one stage to the next and the most energy efficient operation. For most installations the energy savings makes this the most cost effective configuration.

3.1.4. Mixed Pump Configuration

The Mixed Pump configuration supports a mix of variable speed pumps connected to Drives as well as additional fixed speed pumps. In this configuration all of the variable speed pumps and Drives must be the same size. The fixed speed pumps may be of different sizes. The variable speed pumps are staged on and staged off first based on Drive speed. The fixed speed pumps are then staged on last and staged off last based on the feedback pressure.

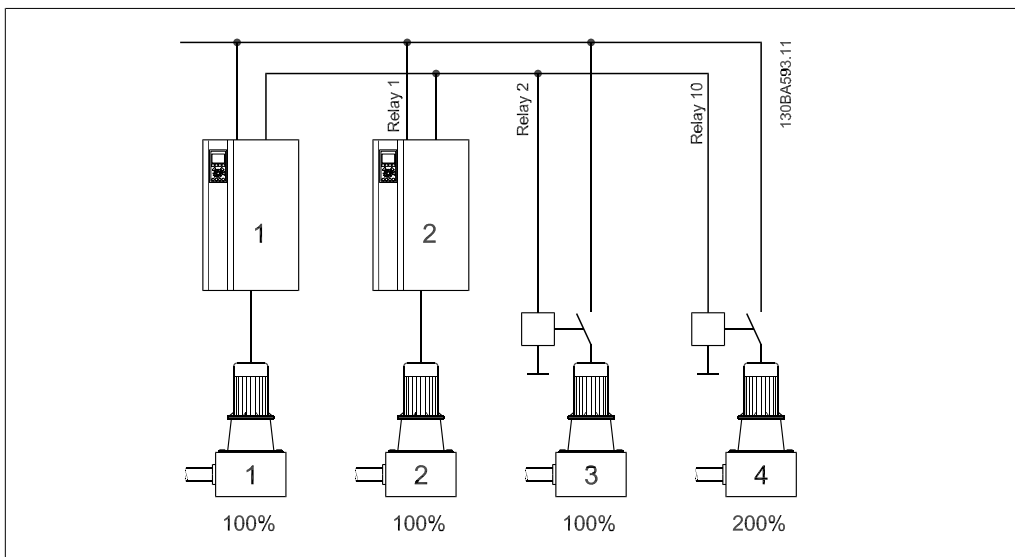

Illustration 3.3: Example

For this configuration relay selections in Group 27-7* “Connections” are as follows:

- 27-70 RELAY 1 → [1] Drive 2 Enable
- 27-71 RELAY 2 → [74] Pump 3 to Mains
- 27-72 RELAY 10 → [75] Pump 4 to Mains
- 27-73 RELAY 11 → [0] Standard Relay
- 27-74 RELAY 12 → [0] Standard Relay

This configuration provides some of the benefits of the Master Follower configuration with some of the initial cost savings of the Fixed Speed configuration. It is a good choice when the extra capacity of the fixed pumps is rarely needed.

3.1.5. Unequal Size Pump Configuration

The Unequal Size Pump configuration supports a limited mix of fixed speed pumps in different sizes. It provides for the largest range of system output with the smallest number of pumps.

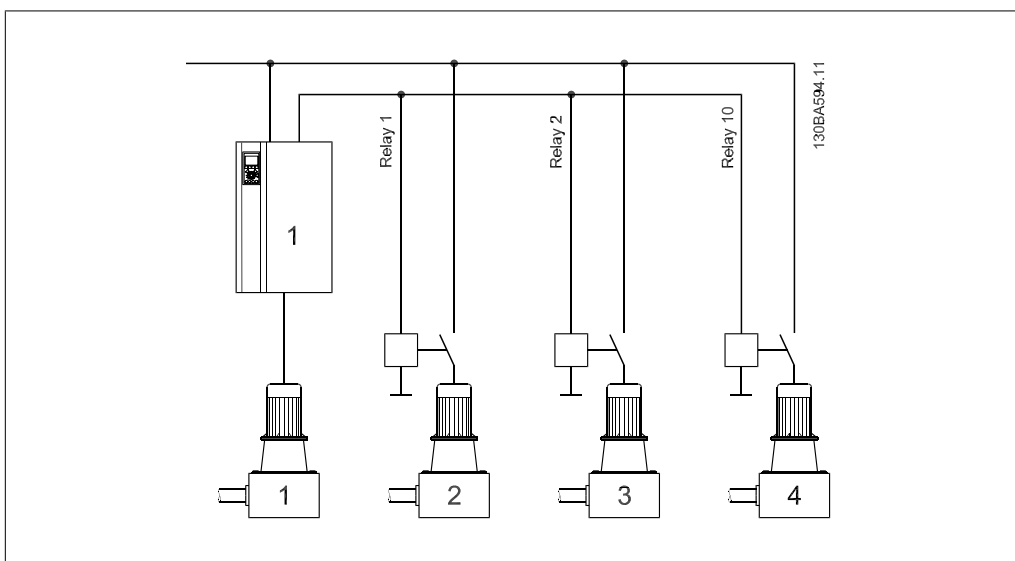

Illustration 3.4: Example

For this configuration relay selections in Group 27-7* "Connections" are as follows:

- 27-70 RELAY 1 → [73] Pump 2 to Mains
- 27-71 RELAY 2 → [74] Pump 3 to Mains
- 27-72 RELAY 10 → [75] Pump 4 to Mains
- 27-73 RELAY 11 → [0] Standard Relay
- 27-74 RELAY 12 → [0] Standard Relay

Not all configurations of unequal size pumps are valid. For a configuration to be valid it must be possible to stage pumps in increments of 100% of the size of the Master Drive's variable speed pump. This is necessary since the variable speed pump must be able to control the output between the fixed speed stages.

Valid Configurations

100% is defined as the maximum flow produced by the pump connected to the Master Drive. The fixed speed pumps must be multiples of this size.

Variable Speed	Fixed Speed
100%	100% + 200%
100%	100% + 200% + 200%
100%	100% + 100% + 300%
100%	100% + 100% + 300% + 300%
100%	100% + 200% + 400%
100% + 100%	200%
100% + 100%	200% + 200%

(Other valid configurations are possible)

Invalid Configurations

Invalid configurations will still run but will not stage on all of the pumps. This is done to allow for limited operation if a pump fails or is interlocked in this configuration.

Variable Speed	Fixed Speed	
100%	200%	(no control between 100% and 200%)
100%	100% + 300%	(no control between 200% and 300%)
100%	100% + 200% + 600%	(no control between 400% and 600%)

3.1.6. Mixed Pump Configuration with Alternation

In this configuration is possible to alternate the Drive between two pumps along with controlling additional fixed speed pumps. The cascade controller will attempt to balance the running hours between all of the pumps as specified by the Runtime Balancing parameter.

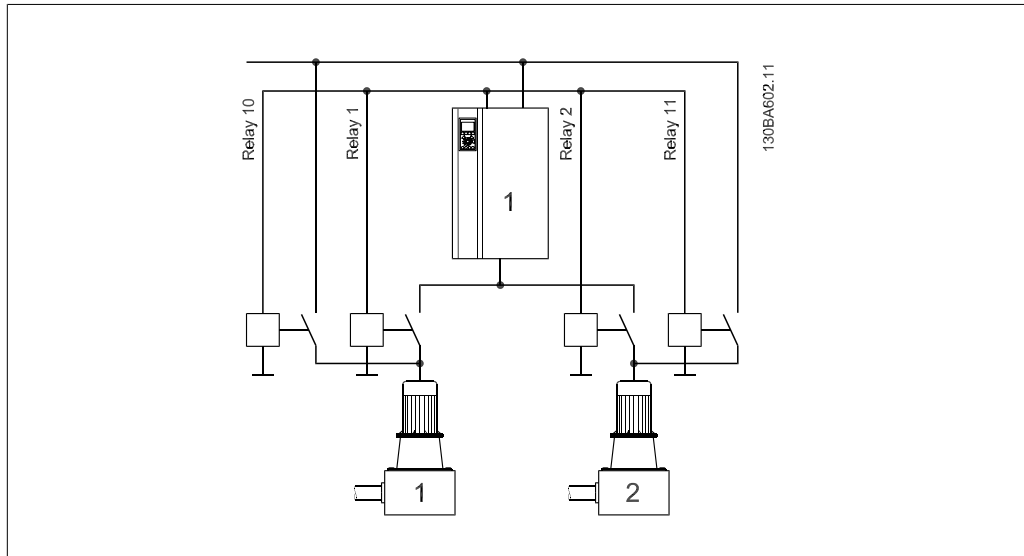

Illustration 3.5: Example 1

The two pumps can be either variable speed or fixed speed with equal running hours.

For this configuration relay selections in Group 27-7* "Connections" are as follows:

- 27-70 RELAY 1 → [8] Pump 1 to Drive 1
- 27-71 RELAY 2 → [16] Pump 2 to Drive 1
- 27-72 RELAY 10 → [72] Pump 1 to Mains
- 27-73 RELAY 11 → [73] Pump 2 to Mains
- 27-74 RELAY 12 → [0] Standard Relay

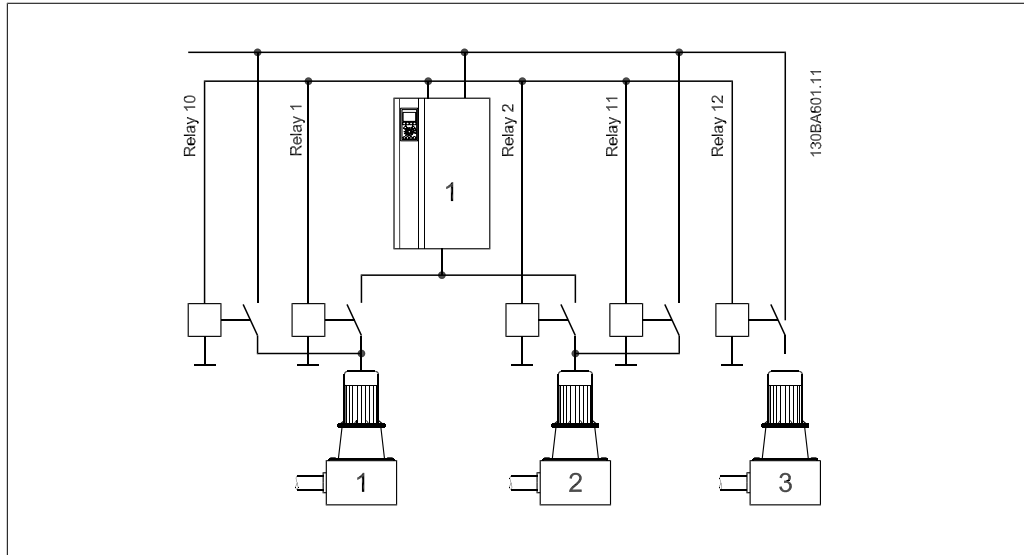

Illustration 3.6: Example 2

The first two pumps can be either variable speed or fixed speed with equal running hours between all three pumps as long as the system demand is typically greater than 1 pump.

For this configuration relay selections in Group 27-7* "Connections" are as follows:

- 27-70 RELAY 1 → [8] Pump 1 to Drive 1
- 27-71 RELAY 2 → →[16] Pump 2 to Drive 1
- 27-72 RELAY 10 → [72] Pump 1 to Mains

27-73 RELAY 11 → [73] Pump 2 to Mains

27-74 RELAY 12 → [74] Pump 3 to Mains

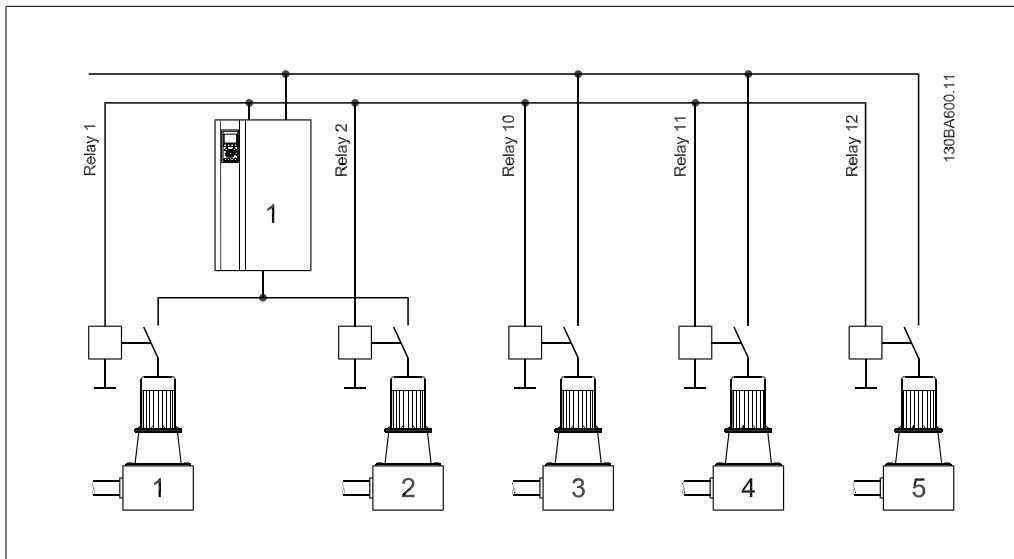

Illustration 3.7: Example 3

The first two pumps alternate each with 50% of the running hours. The fixed speed pumps turned on and off as needed with equal running time between them.

For this configuration relay selections in Group 27-7* "Connections" are as follows:

27-70 RELAY 1 → [8] Pump 1 to Drive 1

27-71 RELAY 2 → [16] Pump 2 to Drive 1

27-72 RELAY 10 → [74] Pump 3 to Mains

27-73 RELAY 11 → [75] Pump 4 to Mains

27-74 RELAY 12 → [76] Pump 5 to Mains

3.1.7. Soft Starters

Soft Starters can be used in place of contactors for any configuration using fixed speed pumps. If Soft Starters are selected, they must be used for ALL fixed speed pumps. Mixing Soft Starters and contactors will result in an inability to control the output pressure during staging and destaging transitions. When using softstarters a delay will be added from staging signal occurs until staging takes place. The delay is necessary due to the ramp time of the fixed speed pump because of the softstarter.

4. Configuring the System

4.1.1. Introduction

The Extended Cascade Controller can be quickly configured using many of the default parameters. However, it is first necessary to describe the configuration of Drives and pumps in the system and to describe the desired level of control of the systems output.

4.1.2. Defining the Hardware Configuration

Parameter groups 27-1* "Configuration" and 27-7* "Connections" are used to define the hardware configuration of the installation. Start the configuration of the cascade controller by selecting values for the parameters in the 27-1* "Configuration" group.

Parameter no.	Description
27-10	Cascade Controller can be used to enable or disable the Extended Cascade Controller. The Mixed Pump selection is the general selection for the cascade controller. If using one Drive per pump the Master-Follower configuration can be selected reducing the number of parameters needed to setup the system.
27-11	Number of Drives
27-12	Number of Pumps - Will default to the Number of Drives.
27-14	Pump Capacity for each pump (Indexed Parameter) - If all of the pumps are the same size the default values shall be used. To adjust: first choose pump, click OK and adjust the capacity.
27-16	Runtime Balancing for each pump (Indexed Parameter) - If the system should equally balance the running hours between the pumps then use the default values.
27-17	Motor Starters - All fixed speed pumps must be the same.
27-18	Spin Time for Unused Pumps - Depends on the size of the pumps.

Next the relays used to turn pumps on and off need to be defined. Parameter group 27-7* "Connections" provides a list of all of the available relays:

- Each Follower Drive in the system needs to have one relay assigned to enable/disable the Drive as needed.
- Each Fixed speed pump needs to have one relay assigned to control the contactor or enable the soft starter to turn the pump on/off.
- If it necessary to have a single Drive alternate between two pumps then additional relays need to be assigned to provide this capability.

Any unused relays will be available for other functions through the 05-4* parameter group.

4.1.3. Additional configuration for Multiple Drives

When more than one Drive is used in the cascade controller it is necessary for the Master Drive to tell the Follower Drives how fast to run. This is accomplished through a digital signal between the Drives.

The Master drive must use a digital output pin to output the required frequency for all of the Drives. All of the Drives always run at the same speed. Setting parameter 05-60 to [116] Cascade Reference will select pin 27 for this function.

Each of the Follower Drives must then be set to open loop and must use a digital input as their speed reference. This can be done by setting parameter 01-00 Configuration Mode to [0] Open Loop and parameter 03-15 to selection [7] Frequency Input 29.

The 03-41 Ramp Up Time and 03-42 Ramp Down Time must be the same for the Master Drive and for all of the Follower Drives in the system.

These ramps should be set fast enough that the PID controller is able to maintain control of the system.

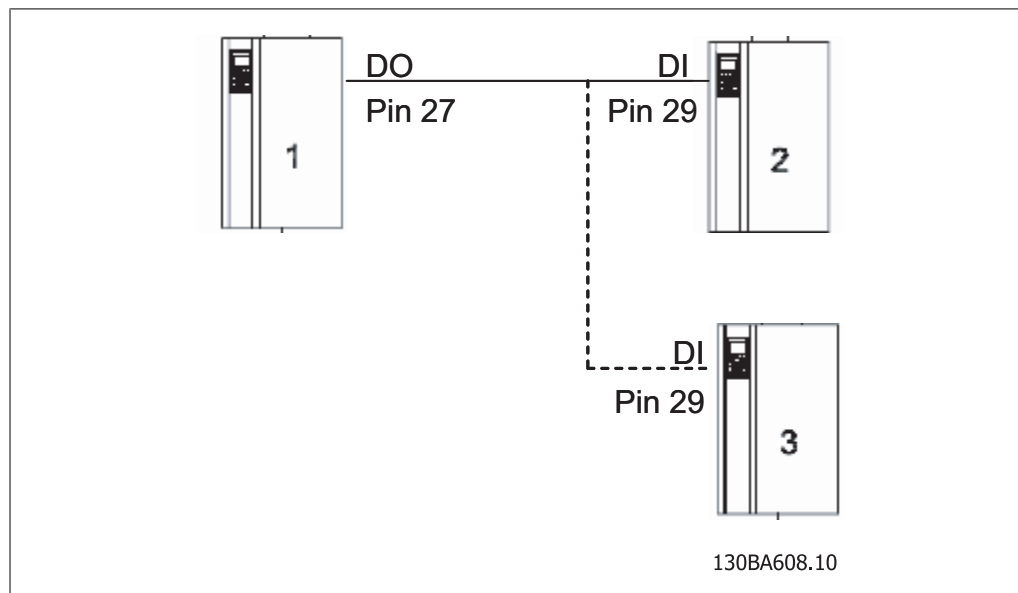

4.1.4. Closed Loop Control

The Master Drive is the primary controller for the system. It monitors the output pressure, adjusts the speed of the Drives and decides when to add or remove stages. To perform this function the Master Drive must be setup in closed loop mode with a feedback sensor connected to an analog input of the Drive.

The PID controller of the Master Drive must be setup to match the needs of the installation. Setting up the PID parameters is described in the *VLT AQUA Drive Programming Guide* and will not be covered in this manual.

4.1.5. Staging /Destaging of variable speed pumps based on Drive Speed

In Master-Follower configurations and Mixed Pump configurations the variable speed pumps are staged and destaged based on the speed of the Drives.

Staging occurs when the speed of the Drives has reached the value in parameter 27-31 (27-32) Stage on Speed. At this speed the system pressure is still maintained but the pumps are beginning to operate outside of their peak efficiency points. Staging on an additional pump will lower the speed of all of the running pumps and provide a more energy efficient operation.

Destaging occurs when the speed of the Drives drops below the value in parameter 27-33 (27-34) Stage Off Speed. At this speed the system pressure is still maintained but the pumps are beginning

to operate below their peak efficiency points. Destaging a pump will cause the speed of the Drives to increase into a more energy efficient range.

Parameters 27-31 (27-32) Stage on Speed and 27-33 (27-34) Stage Off Speed are installation dependent. These parameters are indexed parameters with one set of entries for each pump stage.

Danfoss has available the Multiple Unit Staging Efficiency Calculator (MUSEC), a free software program available on the Danfoss website. By entering pump and system data, MUSEC provides the optimal settings for the Stage on Speed and Stage off Speed parameters.

4.1.6. Staging Destaging of fixed speed pumps based on Pressure Feedback

Fixed speed pumps are staged based on a drop in system pressure. And are destaged based on an increases in system pressure.

Since it is undesirable to have pumps turning on and off rapidly, an acceptable range of system pressure needs to be defined along with a period of time the pressure is allowed to be outside of this band before staging or destaging occurs. These values are set through parameters 27-20 "Normal Operating Range" 27-23 "Staging Delay" and 27-24 "Destaging Delay".

These parameters are installation dependent and should be set to meet the requirements of the system.

5. Running the Extended Cascade controller

5.1.1. Introduction

Once the Cascade controller has been configured it can be enabled or disabled through parameter 27-10 "Cascade Controller".

To start the cascade controller the Master Drive needs to be started as a normal Drive through the LCP or through field buss communications. It will then attempt to control the system pressure by varying the speed of the Drive and by staging on and off pumps as needed.

Two stop functions are provided by the cascade controller. One function quickly stops the system. The other stages off pumps in a sequence, allowing for a pressure controlled stop.

For VLT AQUA Drive equipped with Safe Stop, Terminal 37 will turn off all relays and coast the Master drive. If any of the digital inputs are set to [8] "Start" and the corresponding terminal is used to control the starting and stopping of the drive then setting the terminal to 0 volts will turn off all relays and coast the Master drive. Pressing the OFF button on the LCP will cause a sequenced destaging of all of the running pumps.

6. Cascade Controller Features

6.1.1. Pump Status and Control

The 27-0* group of parameters provides a convenient place to check on the status of the Cascade Controller and to control individual pumps. In this parameter group it is possible to select a specific pump to view the current status, the current running hours, and the total lifetime hours. From the same location an individual pump can be manually controlled for maintenance purposes.

The parameter group is organized as follows:

	Pump 1	Pump 2	Pump 3	Pump ...
27-01 Status	On Drive	Ready	Offline-off	
27-02 Control	No Operation	No Operation	No Operation	
27-03 Current Hrs	650	667	400	
27-04 Lifetime Hrs.	52673	29345	30102	

Navigate to the 27-0* group on the LCP.
 Use right and left arrows on the LCP to select the pump.
 Use up and down arrows on the LCP to select the parameter



6.1.2. Manual Pump Control

The Extended Cascade Controller allows for complete control of each pump in the system. Through parameter 27-02 pumps can be individually controlled through their selected relays. A pump can be turned on or off outside of the control of the Extended Cascade Controller or can be forced to alternate the lead.

This parameter is different than other value related parameters in that selecting one of these options will cause the action to occur and then the parameter will revert back to its default state.

The choices are as follows:

- No Operation - Default.
- Online - Makes the pump available to the Extended Cascade Controller.
- Alternate On - Forces the selected pump to be the lead pump.
- Offline-Off - Turns the pump off and makes it unavailable for cascading.
- Offline-On - Turns the pump on and makes it unavailable for cascading.
- Offline-Spin - Initiates a pump spin.

If any of the "Offline" selections are chosen the pump will no longer be available to the cascade controller until "Online" is selected.

If a pump is taken offline through parameter 27-02 the cascade controller will attempt to compensate for the unavailable pump.

- If "Offline-Off" is selected for a pump that is running, a different pump will be staged on to compensate for the loss of output.
- If "Offline-On" is selected for a pump that is currently off, a different pump will be staged off to compensate for the excess output.

6.1.3. Runtime Balancing

The Extended Cascade Controller is designed to balance the running hours between the available pumps. Parameter 27-16 provides a balancing priority for each pump in the system.

Three levels of priority are available:

- Balanced Priority 1
- Balanced Priority 2
- Spare Pump

The cascade controller selects a pump to be staged or destaged based on the pump's maximum capacity (27-14), the Current Runtime Hours (27-03), and the Runtime Balancing (27-16) parameter.

In selecting the pump to be turned on during staging the cascade controller will first attempt to evenly balance the current running hours for all of the pumps with a "Balanced Priority 1" in parameter 27-16.

If all of the Priority 1 pumps are running it will then try to evenly balance the pumps with "Balanced Priority 2" selected.

If all of the Priority 1 and 2 pumps are running it will then select a pumps with "Spare Pump" selected.

During destaging the reverse occurs. Spare Pumps are destaged first, followed by Priority 2 pumps, followed by Priority 1 pumps. At each priority level the pump with the largest Current Runtime Hours will be destaged first.

An exception to this occurs in Mixed Pump configurations with more than one Drive. All variable speed pumps are staged on before fixed speed pumps.

Variable speed pumps are also staged off before fixed speed pumps. Parameter 27-19 is used to reset the Current Runtime Hours for all of the pumps and restart the balancing process. This parameter will not affect the Total Lifetime Hours (27-04) for each pump. Total Lifetime Hours is not used for runtime balancing.

6.1.4. Pump Spin for unused pumps

For some installations not all of the pumps are needed or used on a regularly basis. When this occurs the Extended Cascade Controller will first try to balance the running hours between pumps by alternating when possible. If however it is unable to use a pump for 72 hours it will initiate a Pump Spin for that pump.

This feature is intended to make sure that no pump is allowed to sit idle for an extended period of time. The Spin Time can be set with parameter 27-18. The Spin Time should be long enough to ensure that the pump stays in good working condition but short enough not to over pressure the system. Setting 27-18 to zero disables the function.

The Extended Cascade Controller will not compensate for the extra pressure generated during a pump spin. It is advisable to keep the Spin Time as short as possible to prevent damage caused by over pressuring the output.

6.1.5. Total lifetime hours

For maintenance purposes the Extended Cascade Controller is designed to help you keep track of the total lifetime hours for each pump it controls.

The Pump Total Lifetime Hours parameter 27-04 displays a running total of the operating hours for each pump. This parameter is updated whenever a pump is running and is saved to non-volatile memory once every hour.

This parameter can also be set to an initial value to reflect the hours of operation for a pump before it was added to the system.

Lifetime hours will only be accumulated by the Cascade Controller if it is enabled and controlling the pump.

6.1.6. Alternation of the Lead Pump

In a configuration with multiple Drives, the Lead Pump is defined as the last variable speed pump running.

In a configuration with only a single Drive, the Lead Pump is defined as the pump connected to the Drive. More than one pump can be connected to the Drive through contactors controlled by the Master Drive's relays.

Through normal staging and destaging the cascade controller will alternate the Lead Pump to balancing running hours. It will also alternate the Lead Pump when starting the system or when exiting sleep mode.

However if the system demand stays below the maximum capacity of the Lead Pump for a long period of time without entering sleep mode then it will not alternate the pump. If this is likely the Lead Pump can be forced to alternate through a Time Interval parameter 27-52 or through a Time of Day parameter 27-54.

6.1.7. Staging / Destaging in Mixed Pump Configurations

Two methods are used to decide when pumps should be staged or destaged. The first is the speed of the Drives. The second is the feedback pressure going outside of the Normal Operating Range. In a Mixed Pump configuration with more than one Drive both methods are used. In the following example, feedback is referred to as pressure.

Staging:

When the Master Drive receives a start command a variable speed pump is selected, and started using one of the available Drives.

If the system pressure drops, the speed of the Drive increases to meet the demand for more flow. While maintaining the pressure, if the Drive exceeds the Stage on Speed (27-31), and remains above that speed for the Staging Delay (27-23) time, the next variable speed pump is staged on. This repeats for all of the variable speed pumps.

If the cascade controller is still unable to maintain the system pressure with all of the variable speed pumps on at maximum, it will begin to stage on fixed speed pumps. A fixed speed pump will be staged on when the pressure goes below the setpoint by the Normal Operation Range (27-20) percentage and stays there for the Staging Delay (27-23) time. This repeats for all of the fixed speed pumps.

Destaging:

If the system pressure increases, the speed of all of the Drives decrease to match the system's reduced demand for flow. While maintaining pressure, if the Drive goes below the Stage off Speed (27-33) and stays there for the Destaging Delay (27-24) time, a variable speed pump will be staged off. This repeats for all of the variable speed pumps except the last one.

If the system pressure is still too high with only one Drive running at minimum speed, it will begin to destage fixed speed pumps. A fixed speed pump will be destaged when the pressure goes above the setpoint by the Normal Operating Range (27-20) percentage and stays there for the Destaging Delay (27-24) time. This repeats for all of the fixed speed pumps. This leaves only one variable speed pump running. If the system demand continues to drop the system will enter sleep mode.

6.1.8. Override Staging /Destaging

Normal staging and destaging handles most of the situations in typical applications. However sometimes it is necessary to respond rapidly to changes in system feedback pressure. In these cases the cascade controller is equipped to immediately stage and destage pumps in response to large changes system demand.

Staging:

When the system pressure drops by more than the Override Limit (27-21), the cascade controller will immediately stage on a pump to meet the demand for more flow.

If the system pressure continues to stay below the Override Limit (27-21) for the Override Hold Time (27-25) time, the cascade controller will then stage on the next pump. This repeats until all of the pumps are on or until the system pressure drops below the Override Limit.

Destaging:

When the system pressure increases rapidly above the Override Limit (27-21), the cascade controller will immediately destage a pump to try to reduce the pressure.

If the system pressure continues to stay above the Override Limit (27-21) for the Override Hold Time (27-25) time, the cascade controller will destage another pump. This will repeat until only the lead pump is left on or until the pressure stabilizes.

The Override Limit parameter 27-21 is set as a % of the Maximum Reference. It defines a point above and below the system Setpoint where Override staging and destaging will occur.

6.1.9. Minimum Speed Destaging

To reduce emergency usage the cascade controller will destage a pump if the Lead Pump is running at minimum speed for Min Speed Destage Delay (27-27).

6.1.10. Fixed speed only operation

Fixed Speed only operation is a feature designed to keep critical systems operating in the rare event that all of the variable speed pumps are unavailable to the cascade controller. In this situation the cascade controller will attempt to maintain system pressure by turning on and off fixed speed pumps.

Staging:

If all the variable speed pumps are unavailable and the system pressure goes below the Fixed Speed Only Operating Range (27-22) for the Staging Delay (27-23) time, then a fixed speed pump will be turned on. This repeats until all of the pumps are on.

Destaging:

If all of the variable speed pumps are unavailable and the system pressure goes above the Fixed Speed Only Operating Range (27-22) for the Destage Delay (27-24) time, a fixed speed pump will be turned off. This repeats until all of the pumps are off.

7. How to Programme

7.1. Extended Cascade Controller Parameters

7.1.1. Cascade CTL Option, 27-**

Cascade Control Option Parameter group.

7.1.2. Control & Status, 27-0*

Control & Status parameters are for monitoring and manually controlling the pumps.

Use Right [▶] and Left [◀] arrow keys to choose pump. Use Up [▲] and Down [▼] arrow keys to change settings.

27-01 Pump Status

Option:	Function:
	Pump Status is a readout parameter showing the status of each pump in the system Possibilities are:
Ready	the pump is available for use by the cascade controller.
On Drive	the pump is controlled by the cascade controller, and the pump is connected to a drive, and is running.
On Mains	the pump is controlled by the cascade controller, and the pump is connected to mains, and is running.
Offline-Off	the pump is not available for use by the cascade controller, and the pump is off.
Offline-On Mains	the pump is not available for use by the cascade controller, and the pump is connected to mains and is running
Offline-On Mains	the pump is not available for use by the cascade controller, and the pump is connected to mains and is running
Offline-External Inter-lock	the pump has been externally interlocked and is off.
Spinning	the cascade control is executing a spin cycle for the pump.
No Relay Connection	the pump is not directly connected to a drive, and no relay has been assigned to the pump

27-02 Manual Pump Control

Option:	Function:
	Manual Pump Control is a command parameter that allows manual control of individual pump states. Selecting one of these will execute the command and then return to No Operation. Selections are:
[0] *	No Operation Does nothing.

[1]	Online	Makes the pump available to the cascade controller.
[2]	Alternate On	Forces the selected pump to be the lead pump.
[3]	Offline-Off	Turns the pump off and makes the pump unavailable for cascading.
[4]	Offline-On	Turns the pump on and makes the pump unavailable for cascading.
[5]	Offline-Spin	Initiates a pump spin.

27-03 Current Runtime Hours

Option:

Units: hrs

Function:

Current Runtime Hours is a readout parameter showing the total number of hours each pump has been running since last reset. This time is used to balance the running hours between pumps. The times may all be reset to 0 using parameter 27-91.

27-04 Pump Total Lifetime Hours

Range:

0* [0 - 2147483647]

Function:

Pump Total Lifetime Hours is the total operating hours for each connected pump. This parameter may be individually set to any value for maintenance purposes.

7.1.3. Configuration, 27-1*

This parameter group is for configuring the cascade controller option.

27-10 Cascade Controller

Option:
Function:

Cascade Controller Mode sets the operating mode. Selections are:

Disabled	Turns off cascade controller option.
Master/Follower	Operates using only variable speed pumps connected to Drives. This selection simplifies the setup.
Mixed Pumps	Operates using both variable and fixed speed pumps
Basic Cascade Ctrl	Turns off the cascade option and reverts to basic cascade operation (See P25-** in the <i>VLT AQUA Drive Programming Guide</i> for further information). The additional relays on the option can be used to extend the Basic Cascade with 3 relays. Only Basic Cascade functions are available.

27-11 Number of Drives

Range:

1* [1 - 6]

Function:

Number of Drives sets the number of Drives to be controlled by the cascade controller.

27-12 No. of Pumps

<p>Range: Number [No. of Drives - 6] of Drives*</p>	<p>Function: Number of Pumps sets the number of pumps to be controlled by the cascade controller.</p>
----------------------------------------------------------------	------------------------------------------------------------------------------------------------------------------

27-14 Pump Capacity

<p>Range: 100%* [0%(Off) - 800%]</p>	<p>Function: Pump Capacity sets the capacity of each pump in the system relative to the first pump. This is an indexed parameter with one entry per pump. The capacity of the first pump is always considered to be 100%.</p>
-------------------------------------------------	------------------------------------------------------------------------------------------------------------------------------------------------------------------------------------------------------------------------------------------

27-16 Runtime Balancing

<p>Option:</p>	<p>Function: Runtime Balancing sets the priority of each pump for balancing it's running hours. The pumps with the highest priority will be operated before the lower prioritised pumps. If all pumps are set as spare pump they will be staged and destaged as no prioritise is made. It means staged on in the order of 1-2-3 and destaged 3-2-1. Selections are:</p>
-----------------------	------------------------------------------------------------------------------------------------------------------------------------------------------------------------------------------------------------------------------------------------------------------------------------------------------------------------------------------------------------------------------------

[0] *	Balanced Priority 1	Turned on first, turned off last
[1]	Balanced Priority 2	Turned on if no priority 1 pumps are available. Turned off before priority 1 pumps are turned off.
[2]	Spare Pump	Turned on last, turned off first

27-17 Motor Starters

<p>Option:</p>	<p>Function: Motor Starters selects the type of mains starters used on the fixed speed pumps. All of the fixed speed pumps must be configured the same. Selections are:</p>
-----------------------	----------------------------------------------------------------------------------------------------------------------------------------------------------------------------------------

- None (contactors)
- Soft starters
- Star-delta starters

27-18 Spin Time for Unused Pumps

<p>Range: 1.0 s* [0.0 s - 99.0 s]</p>	<p>Function: Spin Time for Unused Pumps sets the length of time to spin unused pumps. If a fixed speed pump has not been run in the last 72 hours, it will be turned on for this time. This is to prevent damage caused by leaving the pump off too long. The spin feature may be disabled by setting the value of this parameter to 0. Warning - Setting this parameter too large may over pressure some systems.</p>
--------------------------------------------------	-----------------------------------------------------------------------------------------------------------------------------------------------------------------------------------------------------------------------------------------------------------------------------------------------------------------------------------------------------------------------------------------------------------------------------------

27-19 Reset Current Runtime Hours

Option:

Function:

Reset Current Runtime Hours is used to reset all of the Current Runtime Hours to zero. This time is used for runtime balancing. Selections:

[0] * Do not reset

[1] Reset

7.1.4. Bandwidth Settings, 27-2*

Parameters for configuring control response.

27-20 Normal Operating Range

Range:

10%* [1% – P27-21]

Function:

Normal Operating Range is the allowed offset from the setpoint before a pump may be added or removed. The system must be outside this limit for the time specified in P27-23 (Staging) or P27-24 (Destaging) before a cascade operation takes place. Normal refers to the system operating with at least one variable speed pump available. This value is entered as a % of Max Reference (See P21-12 in the *VLT AQUA Drive Programming Guide* for further information).

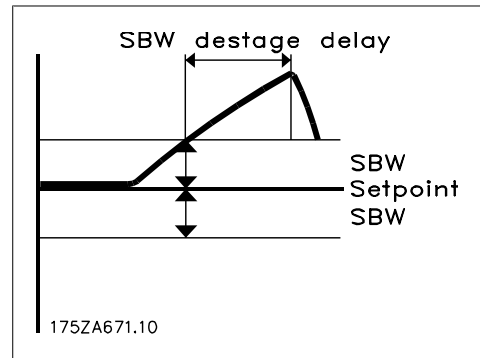
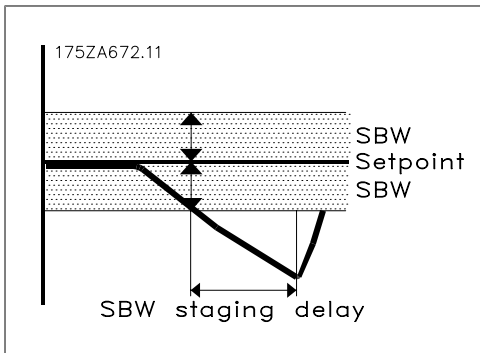

27-21 Override Limit

Range:

100% [P27-20 - 100%]
(Disabled)*

Function:

Override Limit is the allowed offset from the setpoint before a pump will immediately be added or removed (for instance in case of a fire tab is switched on). Normal Operating Range includes a delay that limits the system response to transients. This makes the system respond too slowly to large demand changes. The override limit causes the drive to respond immediately. The value is entered as a % of Max Reference (P21-12). Override operation may be disabled by setting this parameter to 100%.

7

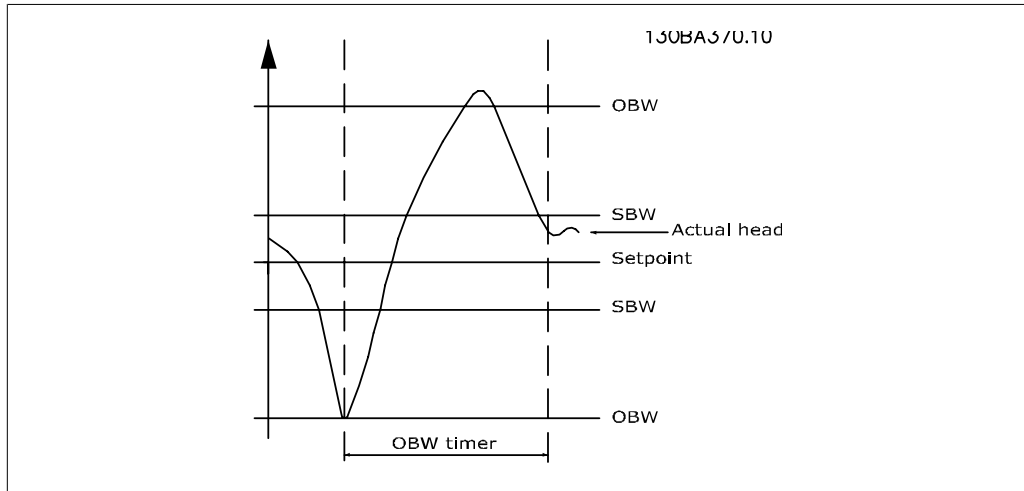

27-22 Fixed Speed Only Operating Range

Range:
P27-20* [P27-20 - P27-21]

Function:
Fixed Speed Only Operating Range is the allowed offset from the setpoint before a pump may be added or removed when there are no operational variable speed pumps. The system must be outside this limit for the time specified in P27-23 (Staging Delay) or P27-24 (Destaging Delay) before a cascade operation may take place. The value is entered as a % of Max Reference. When there are no operational variable speed pumps, the system will try to maintain control with the remaining fixed speed pumps.

7

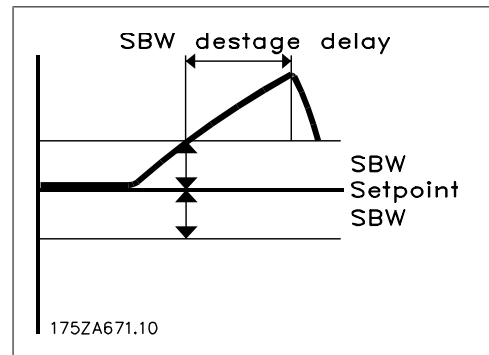
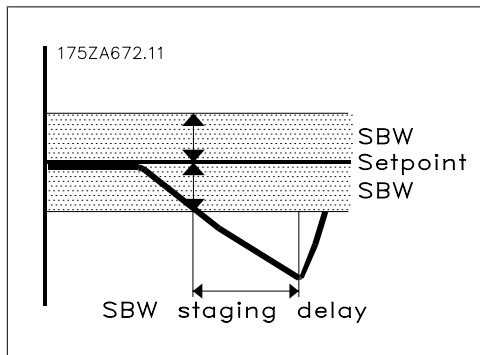

27-23 Staging Delay

Range:
15 s* [0 - 3000 s]

Function:
Staging Delay is the time that the system feedback must remain below the operating range before a pump may be turned on. If the system is operating with at least one variable speed pump available, the Normal Operating Range (P27-20) is used. If there are no variable speed pumps available, the Fixed Speed Only Operating Range (P27-22) is used.

27-24 Destaging Delay

Range:

15 s* [0 - 3000 s]

Function:

Destaging Delay is the time that the system feedback must remain above the operating range before a pump may be turned off. If the system is operating with at least one variable speed pump available, the Normal Operating Range (P27-20) is used. If there are no variable speed pumps available, the Fixed Speed Only Operating Range (P27-22) is used.

27-25 Override Hold Time

Range:

10 s* [0 - 300 s]

Function:

Override Hold Time is the minimum time that must elapse after a stage or destage before a stage or destage may take place due to the system exceeding the Override Limit (P27-21). The override hold time is designed to allow the system to stabilize after a pump is turned on or off. If this delay is not long enough, the transients caused by turning a pump on or off may cause the system to add or remove another pump when it should not.

27-27 Min-Speed Destage Delay

Range:

15 s* [0 - 300 s]

Function:

Min-Speed Destage Delay is the time that the lead pump must be running at minimum speed while the system feedback is still inside the normal operating band before a pump will be turned off to save energy. Energy savings may be realized by turning off a pump if the variable speed pumps are operating at minimum speed but the feedback is still in band. Under these conditions, a pump may be turned off and the system will still be able to maintain control. The pumps that remain on will then be operating more efficiently.

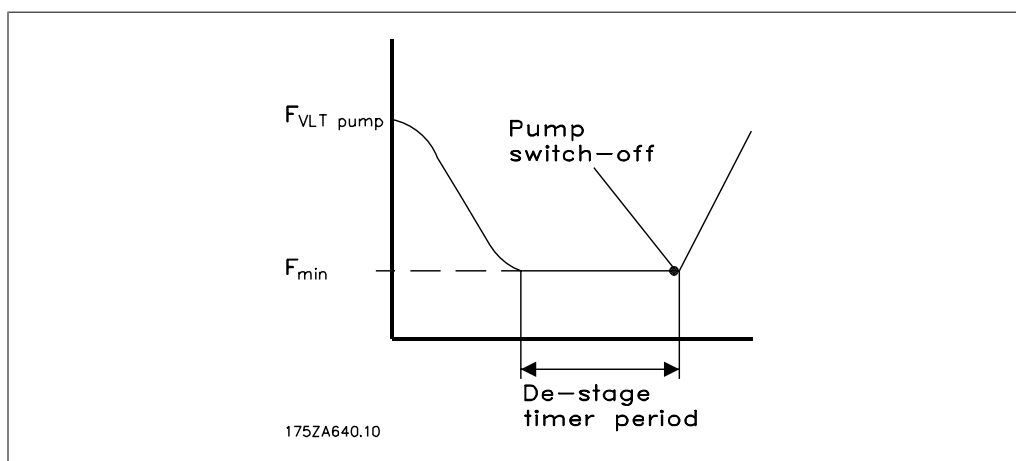

7.1.5. Staging Speed, 27-3*

Parameters for configuring Master/Follower control response.

27-31 Stage On Speed (RPM)

Range:
P4-13* [P4-11 – P4-13]

Function:
To be used if RPM is chosen.
If the lead pump is operating above Stage On Speed for the time specified in Staging Delay (P27-23), and a variable speed pump is available, it will be turned on.

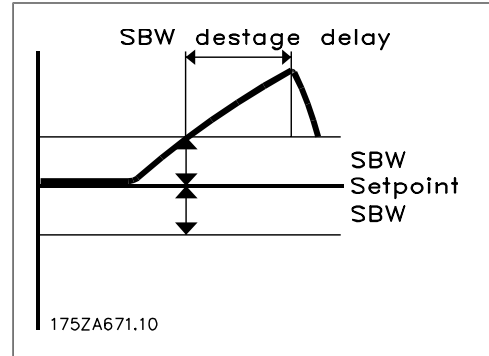
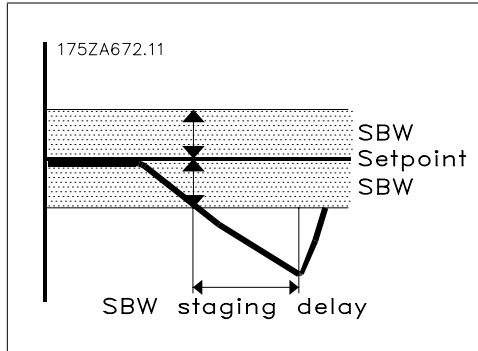

27-32 Stage On Speed (Hz)

Range:
P4-14* [P4-12 – P4-14]

Function:
To be used if Hz is chosen.
If the lead pump is operating above Stage On Speed for the time specified in Staging Delay (P27-23), and a variable speed pump is available, it will be turned on.

27-33 Stage Off Speed (RPM)

Range:
P4-11* [P4-11 – P4-13]

Function:
If the lead pump is operating below Stage Off Speed for the time specified in Destaging Delay (P27-24), and more than one variable speed pump is on, a variable speed pump will be turned off.

27-34 Stage Off Speed (Hz)

Range:
P4-12* [P4-12 – P4-14]

Function:
If the lead pump is operating below Stage Off Speed for the time specified in Destaging Delay (P27-24), and more than one variable speed pump is on, a variable speed pump will be turned off.

7.1.6. Staging Settings, 27-4*

Parameters for configuring staging transitions.

27-41 Ramp Down Delay

Range:
10.0 s* [0.0s – 120.0s]

Function:
Ramp Down Delay sets the delay between turning on a soft starter controlled pump and ramping down the drive controlled pump. This is only used for soft starter controlled pumps.

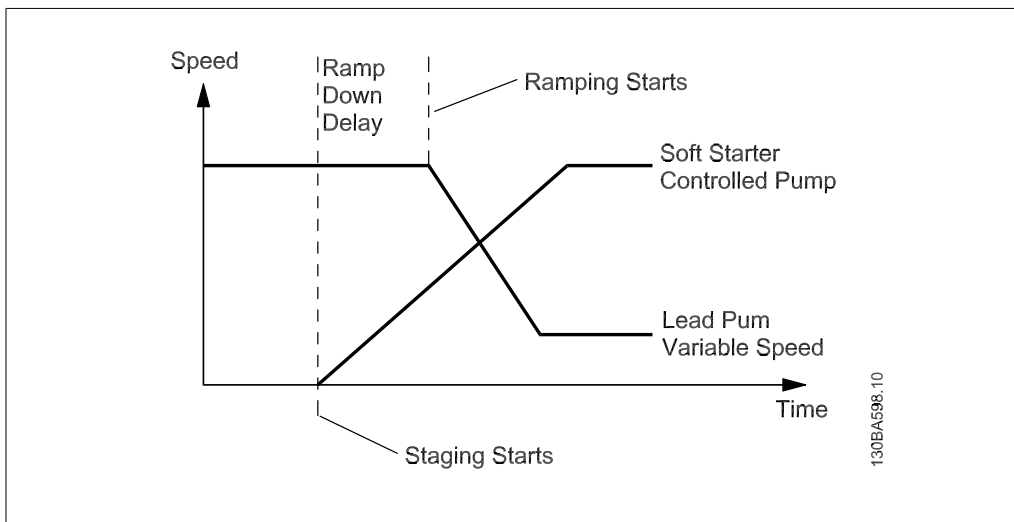

27-42 Ramp Up Delay

Range:

2.0 s* [0.0s – 12.0s]

Function:

Ramp Up Delay sets the delay between turning off a soft starter controlled pump and ramping up the drive controlled pump. This is only used for soft starter controlled pumps.

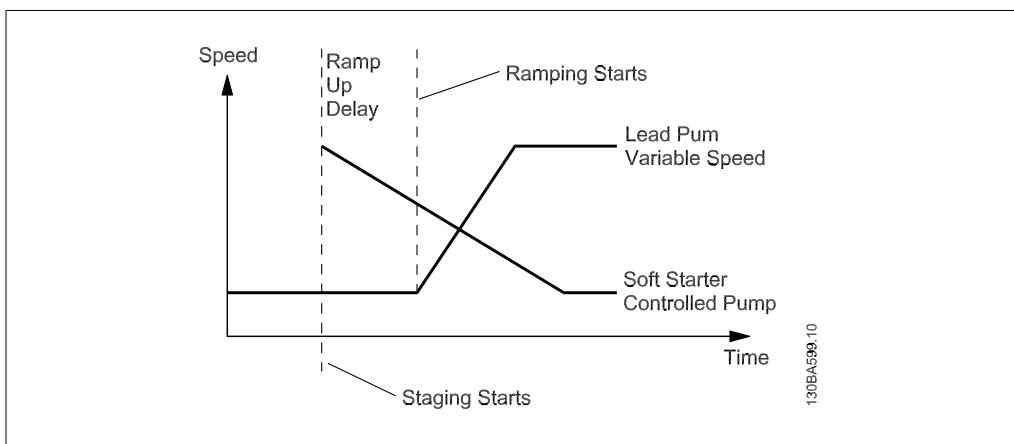

27-43 Staging Threshold

Range:

90%* [1% – 100%]

Function:

Staging Threshold is the speed in the staging ramp at which the fixed speed pump should be turned on. Set as a percentage [%] of maximum pump speed.

7

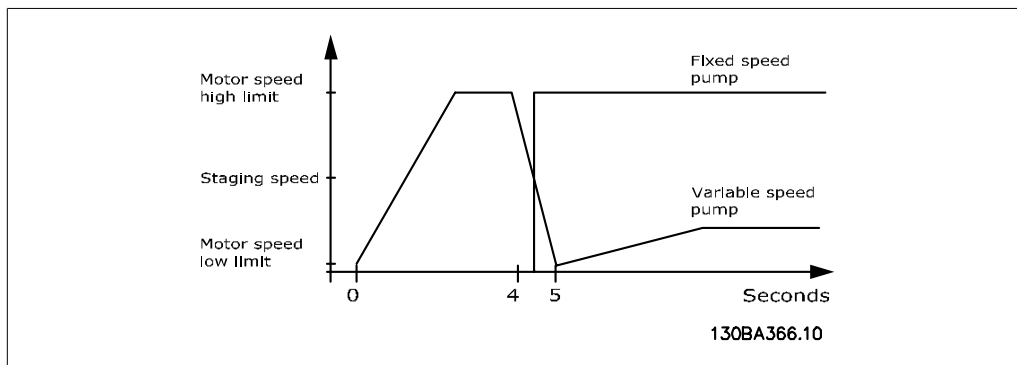

27-44 Destaging Threshold

Range:

50%* [1% – 100%]

Function:

Destaging Threshold is the speed in the staging ramp at which the fixed speed pump should be turned on. Set as a percentage [%] of maximum pump speed.

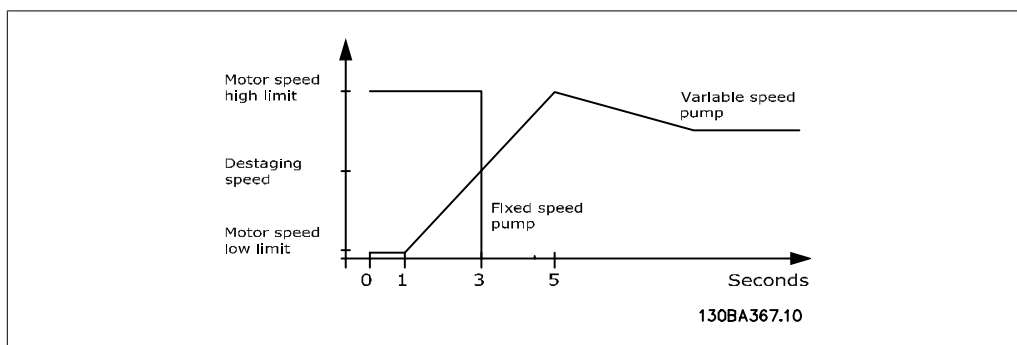

7

27-45 Staging Speed (rpm)

Option:

Units: RPM

Function:

Staging Speed is a readout parameter that shows the actual staging speed based on the staging threshold.

27-46 Staging Speed (Hz)

Option:

Units: Hz

Function:

Staging Speed is a readout parameter that shows the actual staging speed based on the staging threshold.

27-47 Destaging Speed (rpm)

Option:

Units: RPM

Function:

Destaging Speed is a readout parameter that shows the actual destaging speed based on the destaging threshold.

27-48 Destaging Speed (Hz)

Option:

Units: RPM

Function:

Destaging Speed is a readout parameter that shows the actual destaging speed based on the destaging threshold.

7.1.7. Alternation Settings, 27-5*

Parameters for configuring alternations.

27-51 Alternation Event

Option:

[0] * Off

[1] At Destage

Function:

Alternation Event allows alternation at destage.

27-52 Alternation Time Interval

Range:

0 (Disa- [0 (Disabled) – 10000
bled)* m]

Function:

Alternation Time Interval is the user settable time between alternations. It is disabled by setting it to 0. Parameter 27-53 shows the time remaining until the next alternation occurs.

27-53 Alternation Timer Value

Option:

Units: min

Function:

Alternation Timer Value is a readout parameter that shows the time remaining before an interval based alternation takes place. Parameter 27-52 sets the time interval

27-54 Alternate at Time of Day

Option:

[0] * Disabled

[1] Time of Day

Function:

Alternate at Time of Day allows selecting a specific time of day for alternating pumps. The time is set in parameter 27-55. Alternation at Time of Day requires the real time clock to be set.

27-55 Alternation Predefined Time

Range:

1:00* [00:00 – 23:59]

Function:

Alternation Predefined Time is the time of day for pump alternation. This parameter is only available if parameter 27-54 is set to Time of Day.

27-56 Alternate Capacity is <

Range:

0% [0% (Off) – 100%]
(Off)*

Function:

Alternate Capacity is < requires the lead pump to be operating below this capacity before time based alternation will be allowed to take place. This feature ensures that alternation only takes place when the pump is running below a speed where interruption in operation will not affect the process. This minimizes the system disturbance caused by alternations. The value is entered as a % of the capacity of pump 1. Alternate Capacity is < operation may be disabled by setting this parameter to 0%.

27-58 Run Next Pump Delay

Range: 0.1s* [0.1s – 5s]
Function: Run Next Pump Delay is a delay between stopping the current lead pump and starting the next lead pump when alternating lead pumps. This provides time for the contactors to switch while both pumps are stopped.

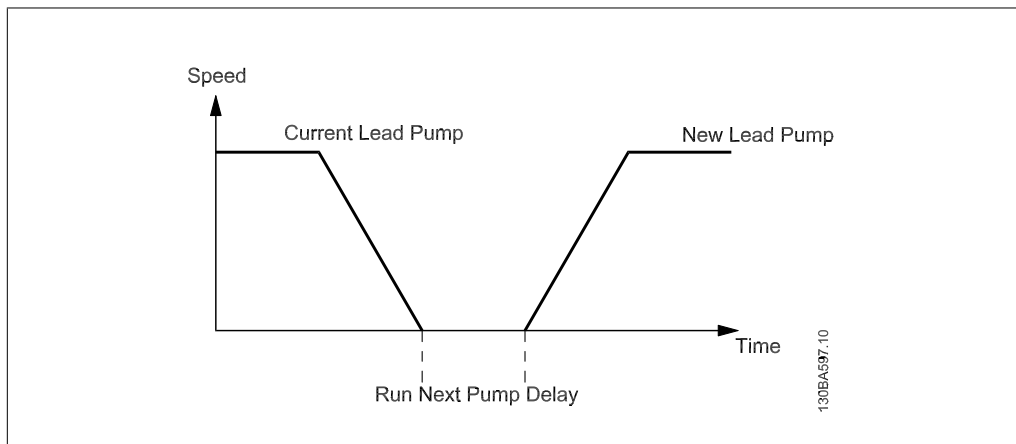

7

7.1.8. Connections, 27-7*

Parameters for configuring relay connections.

27-70 Relay 1

Option:	Function:
Standard Relay	Use as standard relay. Not assigned to cascade controller
[0] Drive X Enable	Enable follower drive X
Pump K to Drive N	Connect pump K to drive N
Pump K to Mains	Connect pump K to mains

27-71 Relay 2

Option: **Function:**
 Relay 2 sets the relay function for Relay 2 in the system. See parameter 27-20 for the available selections.

27-72 Relay 10

Option: **Function:**
 Relay 10 sets the relay function for Relay10 in the system. See parameter 27-20 for the available selections.

27-73 Relay 11

Option: **Function:**
 Relay 11 sets the relay function for Relay11 in the system. See parameter 27-20 for the available selections.

27-74 Relay 12

Option:
Function:

Relay 12 sets the relay function for Relay12 in the system. See parameter 27-20 for the available selections.

7.1.9. 27-9* Readouts

Cascade Control Option Readout Parameters

27-91 Cascade Reference

Cascade Reference is a readout parameter that shows the reference output for use with follower drives. This reference is available even when the master drive is stopped. This is the speed that the drive is operating at or would be operating at if it were on. It is scaled as a percent of *Motor Speed High Limit* (P4-13[RPM] or P4-14[Hz]).

Units: %

27-92 Current % of Total Capacity

Current % of Total Capacity is a readout parameter that shows the system operating point as a % capacity of total system capacity. 100% means all pumps are on at full speed.

Units: %

27-93 Cascade Option Status

Option:
Function:

Cascade Option Status is a readout parameter to show the status of the cascade system.

[0] *	Disabled	The cascade option is not used.
	Off	The cascade option is turned off.
	Running	The cascade option is running normally.
	Running at FSBW	The cascade option is running in fixed speed mode. No variable speed pumps are available.
	Jogging	The system is running at the jog speed set in P3-11.
	In Open Loop	The system is set to open loop.
	Frozen	The system is frozen in the current state. No changes will take place.
	Emergency	The system is stopped due to Coast, Safety Interlock, Trip Lock, or Safe Stop.
	Alarm	The system is operating with an alarm condition.
	Staging	A staging operation is in progress.
	Destaging	A destaging operation is in progress.
	Alternating	An alternation operation is in progress.
	Lead Pump Not Set	A lead pump has not been selected.

Extended/Advanced Cascade controller Parameters									
New #	Group/Parameter Name	Description	Units	Range	Default	Set-ups	Change During Operation	Conversion	Data Type
Cascade CTL Option 27-**									
27-0*	Control & Status								
27-01	Pump Status [x6]	Current state of each pump in the system	--	Text Readout	Readout	All	Readout	1	
27-02	Manual Pump Control [x6]	Command Parameter	--	[0] - [5]	[0] No Operation	All	TRUE	1	
27-03	Current Runtime Hours [x6]	Running hours for this pump since the last reset	hrs	0 - 2147483647	Readout	All	Readout	1	
27-04	Pump Total Lifetime Hours [x6]	Total running hours since this pump was new	hrs	0 - 2147483647	0	All	TRUE	1	
27-1* Configuration									
27-10	Cascade Controller	Selects operating mode	--	[0] - [3]	[0] Disabled	All	FALSE	1	
27-11	Number of Drives	Number of Drives in this configuration	Drives	1 - 8	1	All	FALSE	1	
27-12	Number of Pumps	Number of Pumps in this configuration	Pumps	(27-11) - 8	1	All	FALSE	1	
27-14	Pump Capacity [x6]	Pump Max capacity as a % of 1st pump	% of pump	10% - 800%	100%	All	FALSE	1	
27-16	Runtime Balancing [x6]	Priority for balancing running hrs	--	[0] - [2]	[0] Priority	All	TRUE	1	
27-17	Motor Starters	Enables or disables motor starters.	--	[0] - [2]	[0] Direct Online	All	FALSE	1	
27-18	Spin Time for Unused Pumps	On time for pumps after 72 hrs	sec	0.0 (Off) - 99.0 sec	1.0 s	All	TRUE	1	
27-19	Reset Current Runtime Hours	Command Parameter	--	[0] - [1]	[0] Do not reset	All	FALSE	1	
27-2* Bandwidth Settings									
27-20	Normal Operating Range	Acceptable range around Set Point (SBW)	% of Max Ref	1% - (27-21)%	10%	All	TRUE	1	
27-21	Override Limit	Too far from Set Point causes staging (OBW)	% of Max Ref	(27-20)% - 100% (Disabled)	100% (Disabled)	All	TRUE	1	
27-22	Fixed Speed Only Operating Range	No Drive range around Set Point (FSBW)	% of Max Ref	(27-20)% - (27-21)%	10%	All	TRUE	1	
27-23	Staging Delay	Delay time for staging	sec	0 - 3000 sec	15 sec	All	TRUE	1	
27-24	Destaging Delay	Delay time for destaging	sec	0 - 3000 sec	15 sec	All	TRUE	1	
27-25	Override Hold Time	Min time between staging/destaging/mo-starting	sec	0 - 300 sec	10 sec	All	TRUE	1	
27-27	Min-Speed Destage Delay	Duration the pump is at min speed before destaging	sec	0 - 300 sec (Disabled)	15 sec	All	TRUE	1	
27-3* Staging Speed									
27-31	Stage On Speed [RPM] [x6]	Staging Speed for each pump	rpm	(27-33) - Max Ref	(Each Stage Diff)	All	TRUE	1	
27-32	Stage On Speed [Hz] [x6]	Staging Speed for each pump	Hz	(27-34) - Max Ref	(Each Stage Diff)	All	TRUE	0,1	
27-33	Stage Off Speed [RPM] [x6]	Destaging Speed for each pump	rpm	Min Ref - (27-31)	(Each Stage Diff)	All	TRUE	1	
27-34	Stage Off Speed [Hz] [x6]	Destaging Speed for each pump	Hz	Min Ref - (27-32)	(Each Stage Diff)	All	TRUE	0,1	



New #	Group/Parameter Name	Description	Units	Range	Default	Set-ups	Change During Operation	Conversion	Data Type	
27-4*	Staging Settings									
27-41	Ramp Down Delay	Ramp Down Delay for soft starters	sec	0.0 - 120.0 sec	10.0 sec	All	TRUE	0,1		
27-42	Ramp Up Delay	Ramp Up Delay for soft starters	sec	0.0 - 12.0 sec	2.0 sec	All	TRUE	0,1		
27-43	Staging Threshold	Staging Speed in percent	% Max Ref	1% - 100%	90%	All	TRUE	1		
27-44	Destaging Threshold	Destaging Speed in percent	% Max Ref	1% - 100%	50%	All	TRUE	1		
27-45	Staging Speed [RPM]	Readout Staging Speed in RPM	rpm	0 - Max Ref	Readout	All	Readout	1		
27-46	Staging Speed [Hz]	Readout Staging Speed in Hz	Hz	0 - Max Ref	Readout	All	Readout	1		
27-47	Destaging Speed [RPM]	Readout Destaging Speed in RPM	rpm	0 - Max Ref	Readout	All	Readout	1		
27-48	Destaging Speed [Hz]	Readout Destaging Speed in Hz	Hz	0 - Max Ref	Readout	All	Readout	1		
27-5*	Alternate Settings									
27-51	Alternation Event	Alternate when destaging a pump	--	[0] - [1]	[1] At De-stage	All	TRUE	1		
27-52	Alternation Time Interval	Time interval between the alternations	min	0 (Disabled) - 10000 min	0 (Disabled)	All	TRUE	1		
27-53	Alternation Timer Value	Readout for Alternation timer	min	0 - 10000 min	Readout	All	Readout	1		
27-54	Alternate at Time of Day	Alternate on Time of Day	--	[0] - [1]	[0] Disabled	All	TRUE	1		
27-55	Alternation Predefined Time	Alternation happens at a particular time of day	hrs-min	00:00 - 23:59	01:00	All	TRUE	0,001		
27-56	Alternate capacity is <	Disable alternation if lead pump is > this speed	% Max Ref	0% (Off) - 100%	0% (Off)	All	TRUE	1		
27-58	Run Next Pump Delay	Lead Pump Alternation to Next Pump Delay	sec	0.1 - 5.0 sec	0.1 sec	All	TRUE	0,1		
27-7*	Connections									
27-70	Relay 1	Function for Relay1	--	[0] - [77]	[0] Stand-ard Relay	All	FALSE	1		
27-71	Relay 2	Function for Relay2	--	[0] - [77]	[0] Stand-ard Relay	All	FALSE	1		
27-72	Option Relay 10	Function for Option Relay 10	--	[0] - [77]	[0] Stand-ard Relay	All	FALSE	1		
27-73	Option Relay 11	Function for Option Relay 11	--	[0] - [77]	[0] Stand-ard Relay	All	FALSE	1		
27-74	Option Relay 12	Function for Option Relay 12	--	[0] - [77]	[0] Stand-ard Relay	All	FALSE	1		
27-9*	Readouts									
27-91	Cascade Reference	External Reference for follower drives	% Max Ref	0% - 100%	Readout	All	Readout	0,1		
27-92	% of Total Capacity	Current operating point	% all pumps	0% - 100%	Readout	All	Readout	1		
27-93	Cascade Option Status	Text status for display	--	Text Readout	Readout	All	Readout	1		

Index

C

Cascade Controller Features	21
Closed Loop Control	16
Configuring The System	15
Critical Systems	24

D

Destaging	16
Drive Configurations	9

E

Earth Leakage Current	3
Extended Cascade Controller Option	5

F

Feedback Pressure	10, 23
Feedback Sensor	16
Fixed Speed	24
Fixed Speed Pump	5
Fixed Speed Pump Configuration	9
Fixed Speed Pump Configuration	9
Follower Drive	5

L

Lead Pump	23, 24
Lifetime Hours	23

M

Manual Pump Control	21
Master Drive	6, 19
Master Follower Configuration	10
Master-follower Configuration	10
Mixed Pump Configuration	10, 12
Multiple Drives	23
Multiple Unit Staging Efficiency Calculator	17

O

Open Loop Mode	5
Override Limit	24, 30
Override Staging /destaging	24

P

Pid Controller	16
Pressure Fluctuations	9
Pump Spin	22

R

Runtime Balancing	12, 22
-------------------	--------

S

Safe Stop	19
Single Drive	23
Soft Starters	14
Software Version	3
Spin Time	22, 29
Staging	16
Staging / Destaging	23
Staging And Destaging Decisions	10

Stop Functions.....	19
Supported Configuration.....	9
U	
Unequal Size Pump Configuration.....	11
V	
Variable Speed Pumps.....	5