

Technical requirement:

技术要求

- 1.coil should pass inspection; 产品经检验合格;
- 2.Packing materials should be dry, clean, conform to the provisions of relevant standards  
包装材料应干燥、清洁,符合有关标准的规定;
- 3.Packing environmental requirements: without harmful gas;  
包装环境要求: 无有害气体;
- 4.The product into cartons should be compact, not loose, if there is space, must use the lining material to fill tightly;  
产品装入纸箱后应紧凑,不得松动,如有空隙,须用衬垫物填满;
- 5.Tie the bottom cover at first, Banding belt can't twist; then strengthened with strapping,  
the width of Banding belt is not less than 20mm, the laps is not less than seven;  
最先打纸箱底盖的捆扎,并且捆扎带不能扭曲;最后用捆扎带加固,捆扎带的宽度应不小于20mm,加固的圈数不少于7圈;
- 6.Banding belt can't cover the Danfoss logo;  
Danfoss LOGO保证不会被捆扎带遮盖;
- 7.This product main materials and auxiliary materials must meet the Danfoss ROHS toxic substances control standards.  
本产品所有物料及辅料必须符合Danfoss ROHS有害物质控制标准。
- 8.The unspecified tolerance should comply with packaging material specification 503H-9500.  
未注公差必须符合包装物料技术标准503H-9500

Effective day  
2021-12-21  
Controlled

B-B  
1:14

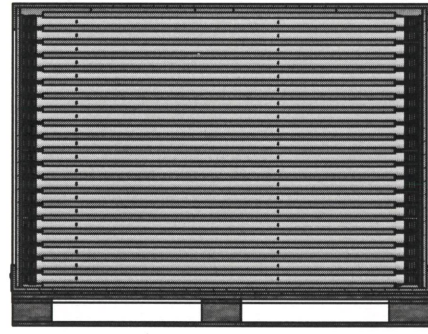
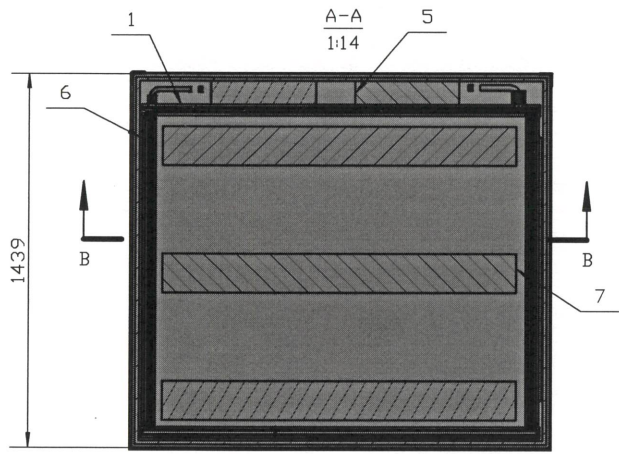

9	993B0395	P08-XXXX	Label		4
9		P07-0001	Protector	cop tube paper	16
8			Strapping tape		7
7	021F5373	P05-0044	separator	honeycomb cardboard	63
6	021F5534	P04-0276	cushion block	honeycomb cardboard	3
5	021F6696	P04-0356	Cushion block	Honeycomb cardboard	2
4	021F6806	P03-0252	Wooden pallet	Plywood	1
3	021F6804	P02-0296	Frame	AAA Corrugated cardboard	1
2	021F6802	P01-0297	Carton cover	ABC Corrugated cardboard	2
1		Z0-AA0372	Condenser		20
ITEM	SAP NO.	PART NUMBER	DESCRIPTION	MATERIAL	QTY

MRK	REVISION RECORD	DRN	CHK	MFG	APP	DATE

PARTS LIST

The unspecified tolerance should comply with packaging material specification	Projection	Scale	Size	Material
DRN Y.NING		1:14	A2	Danfoss standard
CHK		Designation		
STD		Package		
MFG		SAP 021F0207		
APP		TYP. 1605X1439X1239		
DATE 12/20/2021		NO. Z0-AA0372-I REV. AA		

Confidential: Property of Danfoss A/S, Nordborg, Denmark.  
Not to be handed over to, copied or used by third party. Two- or three-dimensional reproduction of contents to be authorized by Danfoss A/S