

Danfoss



Winder and Tension Control Option



VLT® 5000



WINDER AND TENSION CONTROL OPTION

VLT® Series 5000

Introduction page 3

Parameters page 5

This manual is to be used for the Winder and Tension Control Option installed in all VLT 5000 Series Frequency Converters with software version 3.xx.

If the option is used in drives with a VLT 5000 software version higher than 3.40, the functionality of the drive will be that of software version 3.40.

This Winder and Tension Control Option has the software version 13.10.

The software version number can be found in parameter 624.



■ Introduction

A wide range of material-processing machines use tension control to provide a constant pull of a web or wire through the machine in order to ensure consistent product quality. The tension is typically measured by means of a roller mounted on a dancer arm or a load cell. Dancers are generally used where space is not a problem, and load cells in applications where the space is limited. In addition, dancer arms offer much more

control flexibility - particularly during transient conditions like acceleration and deceleration. The tension is created by a winder or a roller.

The web and wire processing applications are typical for the metal, paper, textile, plastics, printing and converting industries.

Danfoss has developed an integrated tension control option for the VLT 5000 which offer an advanced PID process controller with feed forward function.

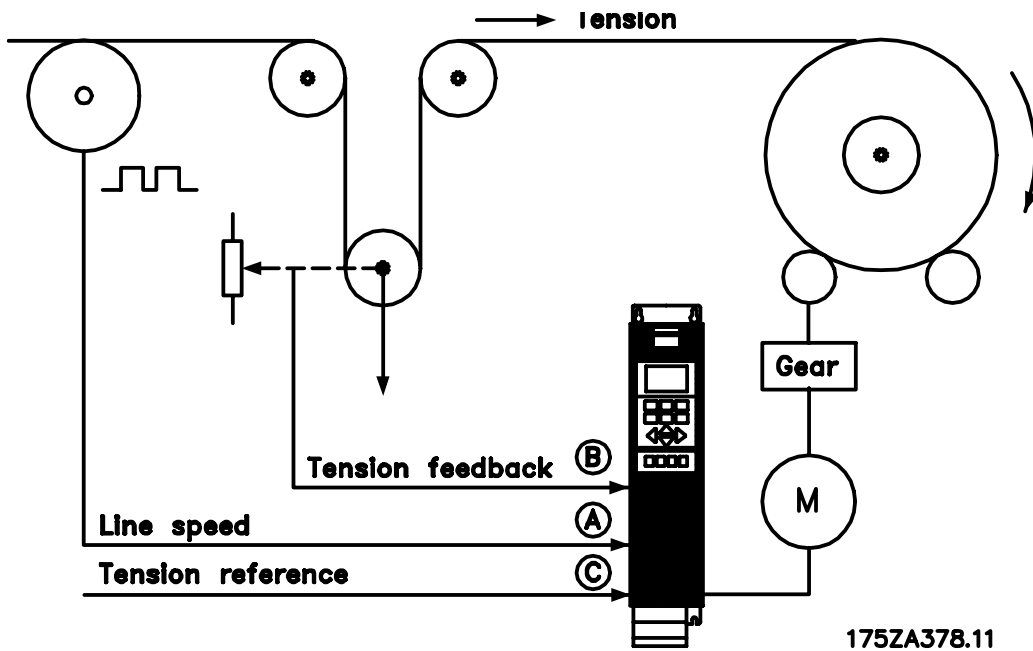

Description of the tension controller option

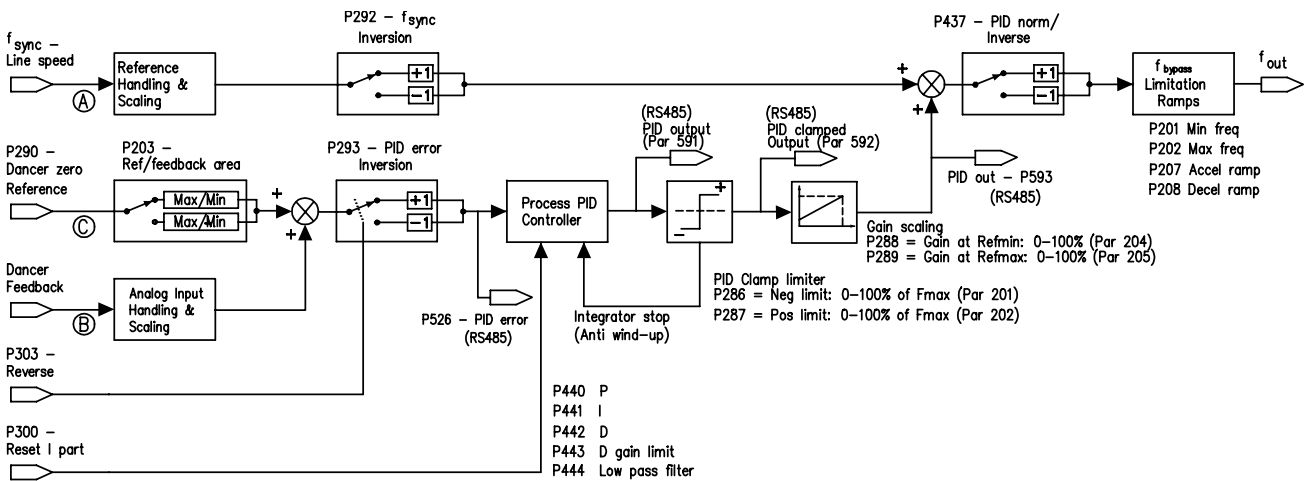

175ZA528.11

■ Features and Benefits

- Consistent tension as a roll unwinds from full roll to core or vice versa due to an advanced PID controller with feed forward function. In unwinding applications brake chopper and brake resistor should be used. Alternatively the DC links of the drives should be inter connected (load sharing).
- Consistent tension, even during splicing and emergency stops as the tension feedback compensates for inertia in the rollers.
- User-friendly, fast commissioning and adjustment: all variables are fully scalable and the functions are programmable as normal or inverse action.
- Programmable dancer position as the zero position is adjustable.
- Reduced dancer oscillations due to adjustable D-gain limit, PID low pass filter and PID clamp limiter.
- Dancer feedback action can be tailor-made to the application due to scalable P-gain.

■ Typical Applications

The controller is primarily suitable for the following applications:

- ① Constant tension surface winders.
- ② Draw applications with common line speed and dancer speed trim.
- ③ Tensionless speed control.

Not suitable for center Winders - no compensation for changing winder radius.

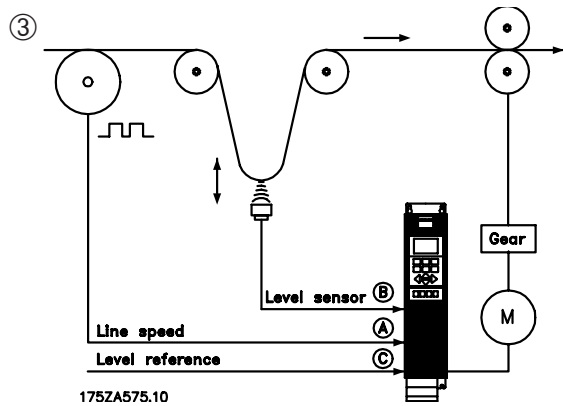

■ Description of the tension controller option

The tension controller is designed as a PID controller with feed forward function. The line speed reference signal is scalable and it is selectable as normal or inverse action. The feedback signal for the PID controller is scalable and the polarity of the feedback signal is selectable. The PID controller allows limiting the D-gain and a selectable PID low pass filter dampens feedback oscillations. A PID anti wind-up function freezes the integrator when reaching the limits of the output frequency.

A PID clamp limiter makes it possible to clamp the PID output to limit the action of the PID controller. The proportional gain scaling makes the P-gain dependent of the actual line speed. These features are useful to dampen oscillations in applications with multiple dancer systems in series.

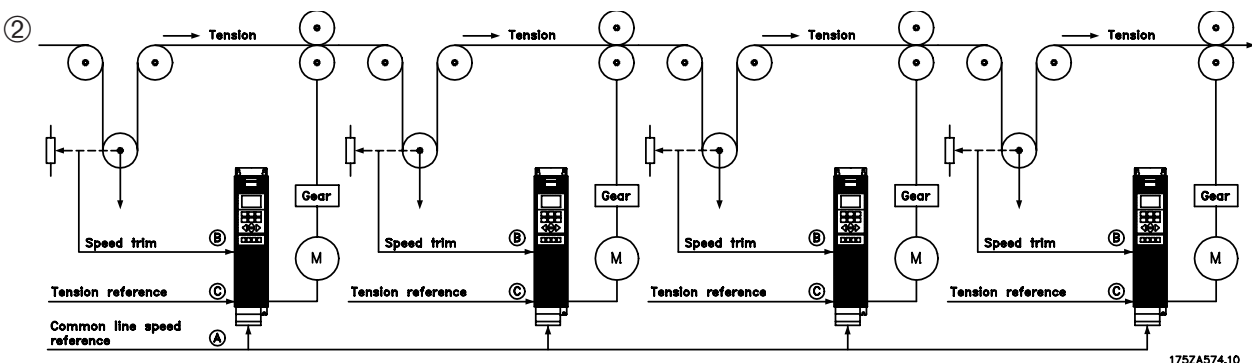
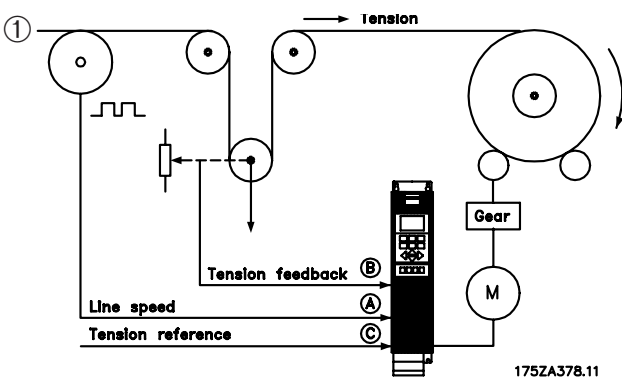

009 Display line 2 (DISPLAY LINE 2)
Value:

Reference [%] (REFERENCE [%])	[1]
Reference [unit] (REFERENCE [UNIT])	[2]
Feedback [unit] (FEEDBACK [UNIT])	[3]
★ Frequency [Hz] (FREQUENCY [Hz])	[4]
Frequency x Scaling [-] (FREQUENCY X SCALE)	[5]
Motor current [A] (MOTOR CURRENT [A])	[6]
Torque [%] (TORQUE [%])	[7]
Power [kW] (POWER [kW])	[8]
Power [HP] (POWER [hp] [US])	[9]
Output energy [kWh] (OUTPUT ENERGY [kWh])	[10]
Motor voltage [V] (MOTOR VOLTAGE [V])	[11]
DC link voltage [V] (DC LINK VOLTAGE [V])	[12]
Thermal load, motor [%] (MOTOR THERMAL [%])	[13]
Thermal load, VLT [%] (VLT THERMAL [%])	[14]
Hours run [Hours] (RUNNING HOURS)	[15]
Digital input [Binary code] (DIGITAL INPUT [BIN])	[16]
Analogue input 53 [V] (ANALOG INPUT 53 [V])	[17]
Analogue input 54 [V] (ANALOG INPUT 54 [V])	[18]
Analogue input 60 [mA]	[19]
(ANALOG INPUT 60 [mA])	[19]
Pulse reference [Hz] (PULSE REF. [Hz])	[20]
External reference [%] (EXTERNAL REF [%])	[21]
Status word [Hex] (STATUS WORD [HEX])	[22]
Brake effect/2 min. [kW]	[23]
(BRAKE ENERGY/2 min)	[23]
Brake effect/sec. [kW]	[24]
(BRAKE ENERGY/s)	[24]
Heat sink temp. [°C] (HEATSINK TEMP [°C])	[25]
Alarm word [Hex] (ALARM WORD [HEX])	[26]
Control word [Hex] (CONTROL WORD [HEX])	[27]
Warning word 1 [Hex]	[28]
(WARNING WORD 1 [HEX])	[28]
Warning word 2 [Hex]	[29]
(WARNING WORD 2 [HEX])	[29]
Winder PID controller error	
(PID ERR)	[30]
Winder PID controller output	
(PID OUT)	[31]
PID clamped output	
(PID clamped out)	[32]
PID line speed scaled output	
(PID gainscaled out)	[33]

Function:

This parameter allows a choice of the data value to be displayed in line 2 of the display.

Parameters 010-012 enable the use of three additional data values to be displayed in line 1.

Description of choice:

Reference [%] corresponds to the total reference (sum of digital/analogue/preset/bus/freeze ref./catch-up and slow-down).

Reference [unit] gives the status value of terminals 17/29/53/54/60 using the unit stated on the basis of configuration in parameter 100 (Hz, Hz and rpm).

Feedback [unit] gives the status value of terminal 33/53/60 using the unit/scale selected in parameter 414, 415 and 416.

Frequency [Hz] gives the motor frequency, i.e. the output frequency from the VLT frequency converter.

Frequency x Scaling [-] corresponds to the present motor frequency f_M (without resonance dampening) multiplied by a factor (scaling) set in parameter 008.

Motor current [A] states the phase current of the motor measured as effective value.

Torque [%] gives the current motor load in relation to the rated motor torque.

Power [kW] states the actual power consumed by the motor in kW.

Power [HP] states the actual power consumed by the motor in HP.

Output energy [kWh] states the energy consumed by the motor since the latest reset was made in parameter 618.

Motor voltage [V] states the voltage supplied to the motor.

DC link voltage [V] states the intermediate circuit voltage in the VLT frequency converter.

Thermal load, motor [%] states the calculated/estimated thermal load on the motor. 100% is the cut-out limit.

Thermal load, VLT [%] states the calculated/estimated thermal load on the VLT frequency converter. 100% is the cut-out limit.

Hours run [Hours] states the number of hours that the motor has run since the latest reset in parameter 619.

Digital input [Binary code] states the signal states from the 8 digital terminals (16, 17, 18, 19, 27, 29, 32 and 33) Input 16 corresponds to the bit at the far left. '0' = no signal, '1' = connected signal.

Analogue input 53 [V] states the signal value on terminal 53.

Analogue input 54 [V] states the signal value on terminal 54.

Analogue input 60 [V] states the signal value on terminal 60.

Pulse reference [Hz] states the possible frequency in Hz connected to the terminals 17 or 29.

External reference [%] gives the sum of the external reference as a percentage (the sum of analogue/pulse/bus).

Status word [Hex] gives the status word sent via the serial communication port in Hex code from the VLT frequency converter.

★ = factory setting. () = display text [] = value for use in communication via serial communication port

Brake power/2 min. [KW] states the brake power transferred to an external brake resistor. The mean power is calculated continuously for the latest 120 seconds.

It is assumed that a resistor value has been entered in parameter 401.

Brake power/sec. [kW] states the present brake power transferred to an external brake resistor. Stated as an instantaneous value.

It is assumed that a resistor value has been entered in parameter 401.

Heat sink temp. [°C] states the present heat sink temperature of the VLT frequency converter. The cut-out limit is $90 \pm 5^\circ\text{C}$; cutting back in occurs at $60 \pm 5^\circ\text{C}$.

Alarm word [Hex] indicates one or several alarms in a Hex code. See page 149 for further information.

Control word. [Hex] indicates the control word for the VLT frequency converter. See *Serial communication* in the Design Guide.

Warning word 1. [Hex] indicates one or more warnings in a Hex code. See page 143 for further information.

Warning word 2. [Hex] indicates one or more status states in a Hex code. See page 143 for further information.

Winder PID controller error corresponds to the error input to the PID controller in percent of the reference/feedback range.

Winder PID controller output states the output frequency of the PID controller in Hertz.

Winder PID clamped output states the output frequency out of the clamp function.

Winder PID line speed scaled output states the output frequency when the line speed dependent scaling factor has been multiplied with the winder PID clamped output.

010 Display line 1.1 (DISPLAY LINE 1.1)

Value:

See parameter 009. ★ Reference [%]

Function:

This parameter enables a choice of the first of three data values to be shown on the display, line 1, position 1.

For display read-outs, press the [DISPLAY/STATUS] button, see also page 45.

Description of choice:

There is a choice of 32 different data values, see parameter 009.

011 Display line 1.2 (DISPLAY LINE 1.2)

Value:

See parameter 009 ★ Motor current [A]

Function:

This parameter enables a choice of the second of the three data values to be shown on the display, line 1, position 2.

For Display read-outs, press the [DISPLAY/STATUS] button, see also page 45.

Description of choice:

There is a choice of 32 different data values, see parameter 009.

012 Display line 1.3 (DISPLAY LINE 1.3)

Value:

See parameter 009 ★ Power [kW]

Function:

This parameter enables a choice of the third of the three data values to be shown on the display, line 1, position 3.

This is a useful function, i.a. when setting the PID regulator.

Display read-outs are made by pressing the [DISPLAY/STATUS] button, see also page 45.

Description of choice:

There is a choice of 32 different data values, see parameter 009.

100 Configuration	
(CONFIG. MODE)	
Value:	
★ Speed control, open loop (SPEED OPEN LOOP)	[0]
Speed control, closed loop (SPEED CLOSED LOOP)	[1]
Process control, closed loop (PROCESS CLOSED LOOP)	[3]
Torque control, open loop (TORQUE OPEN LOOP)	[4]
Torque control, speed feedback (TORQUE CONTROL SPEED)	[5]

Function:

This parameter is used for selecting the configuration to which the VLT frequency converter is to be adapted. This makes adaptation to a given application simple, because the parameters that are not used in the given configuration are covered up (not active). By changing between the different application configurations, bumpless transfer (frequency only) is ensured.

Description of choice:

If *Speed control, open loop* [0] is selected, a normal speed control (without feedback signal) is obtained, but with automatic slip compensation, ensuring a nearly constant speed at varying loads.

Compensations are active, but may be disabled as required in parameter group 100.



If *Speed control, closed loop* [1] is selected, a full holding torque is obtained at 0 rpm, in addition to increased speed accuracy. A feedback signal must be provided and the PID regulator must be set. (See also connection examples in the Design Guide).

If *Process control, closed loop* [3] is selected, the winder specific controller is activated. The standard process control, closed loop is not accessible when the winder option is installed. See also introduction on page 1.

The winder controller specific parameters (290-294) are only accessible if *process control, closed loop* [3] is selected.

See drawing on page 1.

If *Torque control, open loop* [4] is selected, the speed is regulated and the torque is kept constant. This is done without a feedback signal, since VLT 5000 accurately calculates the torque on the basis of the current measurement (See also connection examples in the Design Guide).

If *Torque control, speed feedback* [5] is selected, an encoder speed feedback signal must be connected to the digital terminals 32/33.

Parameter 205 *Maximum reference* and parameter 415 *Maximum feedback* must be adapted to the application if [1], [3], [4] or [5] is selected.

★ = factory setting. () = display text [] = value for use in communication via serial communication port

286 PID output negative clamp

Value:

0-100% Default is OFF

Function:

When active, this function performs a negative clamp on the *winder PID controller output* value. The limit value of the clamp is rated in percent of the max frequency in P205. If OFF is selected the clamp has no function and the *winder PID controller output* is passed through the clamp.

287 PID output positive clamp

Value:

0-100% (OFF) Default is OFF

Function:

When active, this function performs a positive clamp on the *winder PID controller output* value. The limit value of the clamp is rated in percent of the max frequency in P205. If OFF is selected the clamp has no function and the *winder PID controller output* is passed through the clamp.

288 PID gain scale at min. ref.

Value:

0-100.00 Default is 100%

Function:

This parameter relates to P289 and is used to calculate a gain scale factor that is multiplied with the winder PID controller output (after clamping P286/P287) to produce the final PID control output (see the main block diagram).

Description of choice:

This function is mainly intended to stabilise the process output at certain line speeds (references) by reducing the proportional factor of the winder PID controller at these speeds.

Function of proportional gain scaling

Par 200 – One direction only

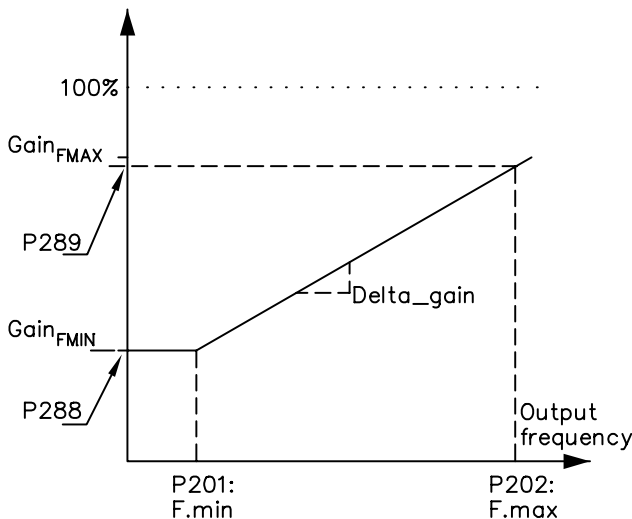

Par 200 – Both directions

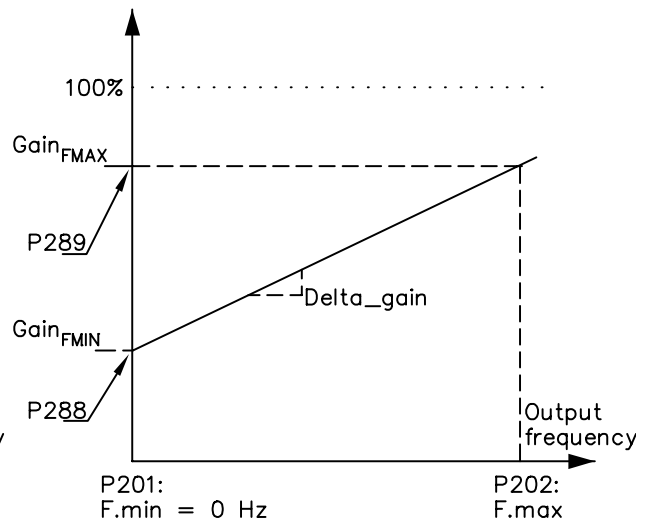

289 PID gain scale at max. ref.
(REF INVERSION)
Value:

 0-100.00 Default is 100%
Function:

This parameter relates to P288 and is used to calculate a gain scale factor that is multiplied with the winder PID controller output (after clamping P286/P287) to produce the final PID control output (see the main block diagram).

Description of choice:

This function is mainly intended to stabilise the process output at certain line speeds (references) by reducing the proportional factor of the winder PID controller at these speeds.

290 Dancer zero setpoint
(DANCER ZERO)
Value:

 -100.00 - 100.00 % ★ 000.00 %
Function:

With this parameter the dancer zero setpoint, i.e the tension reference for the PID controller, is selected. Refer to figure on page 1.

Description of choice:

The percentage selected in this parameter is related to the feedback range determined with parameter 414 and 415. If, for instance, 50 % is selected steady-state operation is achieved when the reference is at 50 % as well.

291 PID controller I-part reset
(RESET I-PART)
Value:

 ★ Off (OFF) [0]
 On (ON) [1]
Function:

With this parameter the integrator of the winder specific PID controller is reset.

Description of choice:

When a reset is activated (On selected), the I-part is reinitialized and the value in P291 is reset to zero. Immediately after that the controller starts integrating again. Refer to parameter 301 for the description of this feature using terminal 17.

292 Line speed ref. inversion
(REF INVERSION)
Value:

 ★ Off (OFF) [0]
 On (ON) [1]
Function:

Whether the reference is added or subtracted to the output of the PID controller is determined by this parameter.

Description of choice:

If a bipolar input (± 10 V) is not available, it is possible to indicate a changed polarity/changed direction with this parameter. OFF means that the frequency is added to the controller output and ON results in a subtraction.

293 PID controller error inversion
(ERROR INVERSION)
Value:

 ★ Off (OFF) [0]
 On (ON) [1]
Function:

If the process is reversed, the sign of the error can be inverted to take account for this situation.

Description of choice:

If this parameter is *Off* a feedback lower than the dancer zero setpoint, will result in an increased output of the controller and vice versa. If *On* is selected a lower feedback results in a decreasing output and vice versa. Please refer to parameter 303 for a description of this feature using terminal 19.

294 Process Start Frequency function
(PR. START FREQ)
Value:

 ★ Disable (DISABLE) [0]
 Enable (ENABLE) [1]
Function:

The function of this parameter is to disable respectively enable Process PID start frequency in parameter 439.

Description of choice:

If *Enable* is selected, the VLT frequency converter ramps the motor in open-loop from zero to the PID start value defined by parameter 439.

Digital inputs	Terminal no.	17	19
	parameter	301	303
Value:			
No function	(NO OPERATION)	[0]	[0]
Reset	(RESET)	[1]	
Stop inverse	(STOP INVERSE)	[2]	
Reversing	(REVERSING)		[1]★
Start reversing	(START REVERSE)		[2]
Only start anti-clockwise, on	(ENABLE START REV)	[3]	[3]
Jog	(JOGGING)	[4]	
Preset reference, on	(PRESET REF. ON)	[5]	
Preset reference, msb	(PRESET REF. MSB)	[6]	
Freeze reference	(FREEZE REFERENCE)	[7]★	
Freeze output	(FREEZE OUTPUT)	[8]	
Speed down	(SPEED DOWN)	[9]	
Choice of Setup, msb	(SETUP SELECT MSB)	[10]	
Slow-down	(SLOW DOWN)	[11]	
Ramp 2	(RAMP 2)	[12]	
Reset I-part	(RESET-I-PART)	[13]	
Pulse reference	(PULSE REFERENCE)	[23]	

301 Terminal 17, input
(DIGITAL INPUT 17)

Function:

With this parameter it is possible to assign different functions to the digital input. Please refer to the Operating Instruction. A new choice enabling a reset of the process controller's I-part is integrated for the special winder software.

Description of choice:

Please refer to the Operating Instruction for a description of choice (1)-(23). If *Reset I-part* [13] is selected, a logical high signal on the terminal will reset the I-part of the process controller. When the signal is removed the I-part is reinitialized and the controller starts integrating. A continuous signal on terminal 17 corresponds to disabling the I-part. See also the description of parameter 291.

304 Terminal 19, input
(DIGITAL INPUT 19)

Function:

Refer to the Operating Instruction.

Description of choice:

If *Reversing* [1] is selected, activating the input will result in an inversion of the PID error, c.f. parameter 293. If Inversion is selected in parameter 293 as well as on terminal 19 the inversion settings will be cancelled in both cases.

★ = factory setting. () = display text [] = value for use in communication via serial communication port

390 Terminal 42, output minimum scaling (OUT 42 SCAL MIN)

Value:
000 - 100 % ☆ 000 %

Function:
The function of this parameter is to scale the analog output signal on terminal 42, see figure below.

392 Terminal 45, output minimum scaling (OUT 45 SCAL MIN)

Value:
000 - 100 % ☆ 000 %

Function:
The function of this parameter is to scale the analog output signal on terminal 45, see figure below.

391 Terminal 42, output maximum scaling (OUT 42 SCAL MAX)

Value:
000 - 100 % ☆ 100 %

Function:
The function of this parameter is to scale the analog output signal on terminal 42, see figure below.

393 Terminal 45, output maximum scaling (OUT 45 SCAL MAX)

Value:
000 - 100 % ☆ 100 %

Function:
The function of this parameter is to scale the analog output signal on terminal 45, see figure below.

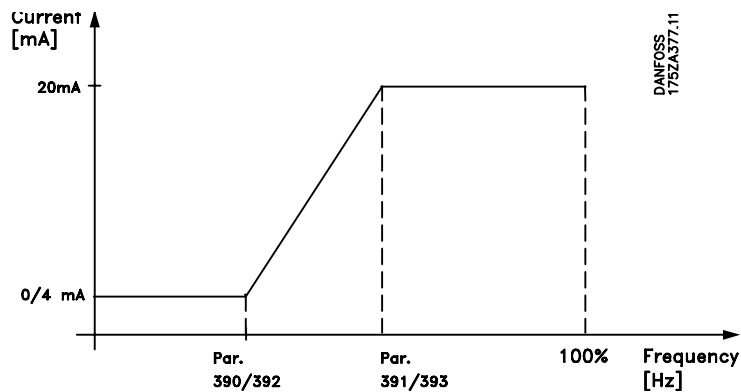

■ Parameter Setup List

Parameter:	Value:	Setting:	Data
009	Display line2		
010	Display line1.1		
011	Display line 1.2		
012	Display line 1.3		
100	Configuration	Process control, closed loop	[4]
200	Output frequency range/direction		
201	Output frequency low limit		
202	Output frequency high limit		
203	Reference/feedback range		
204	Minimum reference	Only if [0] in P203	
205	Maximum reference	This value relates to P415	
286	PID output clamp in reverse operation		
287	PID output clamp in forward operation		
288	PID gain scale at min. ref.		
289	PID gain scale at max. ref.		
290	Dancer zero		
292	Frequency offset inversion		
293	PID controller inversion		
294	Process start frequency function		
301	Terminal 17, digital input		
304	Terminal 19, digital input		
308	Terminal 53, analogue input	Example: Dancer position as 0-10V feedback	[2]
309	Terminal 53, min. scaling	-	0
310	Terminal 53, max. scaling	-	10
311	Terminal 54, analogue input	Example: Line speed of 0-10 V reference	[1]
312	Terminal 54, min. scaling	-	0
313	Terminal 54, max. scaling	-	10
414	Minimum feedback		
415	Maximum feedback	This value relates to P205	
416	Process units	Not important	
437	Process PID normal /inverse		
438	Process PID anti wind-up		
439	Process PID start frequency		
440	Process PID proportional gain		
441	Process PID intergration time		
442	Process PID differentiation time		
443	Process PID diff gain limit		
444	Process PID lowpass filter		



Danfoss can accept no responsibility for possible errors in catalogues, brochures and other printed material. Danfoss reserves the right to alter its products without notice. This also applies to products already on order provided that such alterations can be made without subsequential changes being necessary in specifications already agreed.



www.danfoss.com/drives

Danfoss can accept no responsibility for possible errors in catalogues, brochures and other printed material. Danfoss reserves the right to alter its products without notice. This also applies to products already on order provided that such alterations can be made without subsequential changes being necessary in specifications already agreed. All trademarks in this material are property of the respective companies. Danfoss and the Danfoss logotype are trademarks of Danfoss A/S. All rights reserved.

