

■ Contents

Introduction	2
General warning	2
Introduction	3
Transportation and uncrating	4
Key diagram for VLT 5300-5500 / VLT 6350-6550 / VLT 8350-8550	6
Technical data	7
Mechanical installation	11
Mechanical dimensions	11
Pre-installation	12
Installation site	12
Cable site	13
Derating for high altitude	13
Derating for ambient temperature	13
Electrical installation	14
Electrical installation	14
Pre-fuses	14
Earthing	14
RFI switch	15
Electrical installation, power cables	15
Electrical installation, enclosure	17
Terminal adapter kit	18
Tightening-up torques	18
Installation of 24 Volt external DCsupply	18
Installation of brake resistor temperature switch	18
Cable cross-section and length	19
Mains connection	20
Motor connection	21
Brake connection (VLT 5000 Series ONLY)	22
Load sharing connection	22
Motor and DC coils connections on IP 00	23
Control cable routing	24
Connection example	25
Electrical installation procedures	27
Electrical installation, control leads	28
Programming the VLT 5000	28
Programming the VLT 6000 and VLT 8000 AQUA	28
Motor start	28

■ **General warning**



The voltage of the frequency converter is dangerous whenever the converter is connected to mains. Incorrect fitting of the motor or frequency converter may cause damage to the equipment, serious injury or death. Consequently, it is essential to comply with the instructions in this manual as well as local and national rules and safety regulations.

1. The VLT frequency converter must be disconnected from mains if repair work is to be carried out. Check that the mains supply has been disconnected and that the necessary time has passed before removing motor and mains plugs.
2. The [STOP/RESET] or [OFF/STOP] key on the control panel of the VLT frequency converter does not disconnect the equipment from mains and is thus not to be used as a safety switch.
3. Correct protective earthing of the equipment must be established, the user must be protected against supply voltage, and the motor must be protected against overload in accordance with applicable national and local regulations.
4. The earth leakage currents are higher than 3.5 mA.
5. Protection against motor overload is not included in the factory setting. If this function is desired, set parameter 128 to data value *ETR trip* or data value *ETR warning*. On VLT 6000, set parameter 117 to data value *ETR trip* or data value *ETR warning*.
Note: The function is initialised at 1.16 x rated motor current and rated motor frequency (see Operating manual).

For the North American market: The ETR functions provide class 20 motor overload protection in accordance with NEC.

6. Do not remove the plugs for the motor and mains supply while the VLT frequency converter is connected to mains. Check that the mains supply has been disconnected and that the necessary time has passed before removing motor and mains plugs.
7. Please note that the VLT frequency converter has more voltage inputs than L1, L2 and L3, when loadsharing (linking of DC intermediate circuit) and external 24 V DC have been installed. Check that all voltage inputs have been disconnected and that the necessary time has passed before repair work is commenced.

■ **Warning against unintended start**

1. The motor can be brought to a stop by means of digital commands, bus commands, references or a local stop, while the frequency converter is connected to mains. If personal safety considerations make it necessary to ensure that no unintended start occurs, these stop functions are not sufficient.
2. While parameters are being changed, the motor may start. Consequently, the stop key [STOP/RESET] or [OFF/STOP] must always be activated, following which data can be modified.
3. A motor that has been stopped may start if faults occur in the electronics of the frequency converter, or if a temporary overload or a fault in the supply mains or the motor connection ceases.



Warning:

Touching the electrical parts may be fatal - even after the equipment has been disconnected from mains.

Also make sure that other voltage inputs have been disconnected, such as external 24 V DC, load-sharing (linkage of DC intermediate circuit), as well as the motor connection for kinetic back-up.

Using VLT 5300-5500 / 6350-6550 /8350-8550:
wait at least 15 minutes

176FA055.11

■ Introduction**Manual objectives**

The purpose of this manual is to provide the user with the necessary information to install, program and start up the Danfoss VLT 5300-5500, VLT 6350-6550 and VLT 8350-8550 frequency converters. This manual should be read thoroughly before operating, servicing or initializing the drives. This manual is intended for use along with the Danfoss Operating Instructions Manual for the VLT 5000/6000/8000 frequency converters for detailed information.

Who should use this manual

This manual is intended for qualified service personnel responsible for setting up and servicing the Danfoss VLT 5300-5500, VLT 6350-6550 and VLT 8350-8550 frequency converters. Qualified personnel have previous experience with the frequency converters and understand electrical fundamentals, programming procedures, required equipment and safety precautions.

Organization of the manual

This manual is arranged in equipment installation and connection sequence. The order of tasks are arranged as follows:

- Safety instructions
 - Transportation and unpacking
 - Technical data
 - Mechanical installation
 - Pre-installation
 - Electrical installation guidelines
 - Control cable routing
 - Connection examples
 - Electrical installation procedures
 - Motor start
-

■ Transportation and uncrating

To lessen the possibility of damage it is recommended that the crated VLT frequency converter is located as close to the final installation site as possible before uncrating.

Door and ceiling clearances must be considered when moving and installing the VLT frequency converter. See below table for the crate dimensions:

Dimensions mm (inches):

	H	W	D
IP 00	2096 (82.52)	1219 (48.0)	699 (27.52)
Nema 1 (IP 20) / 54	2324 (91.5)	1321 (52.0)	724 (28.5)

Weight kg (lbs):

	VLT 5300/6350/ 8350/8550	VLT 5350/6400/ 8350/8550	VLT 5450/6500/ 8350/8550	VLT 5500/6550/ 8350/8550
IP 00	548 (1208)	583 (1385)	628 (1385)	653 (1440)
Nema 1 (IP 20)	654 (1442)	689 (1519)	734 (1618)	759 (1673)
IP 54	664 (1464)	699 (1541)	744 (1640)	769 (1695)

A qualified person with a forklift or other similar lifting device will be needed to remove the VLT frequency converter from the crate.

To open the crate:

- Remove the metal locking tabs that secure the top panel of the crate, this will give access to the lifting rings on the top of the VLT frequency converter.

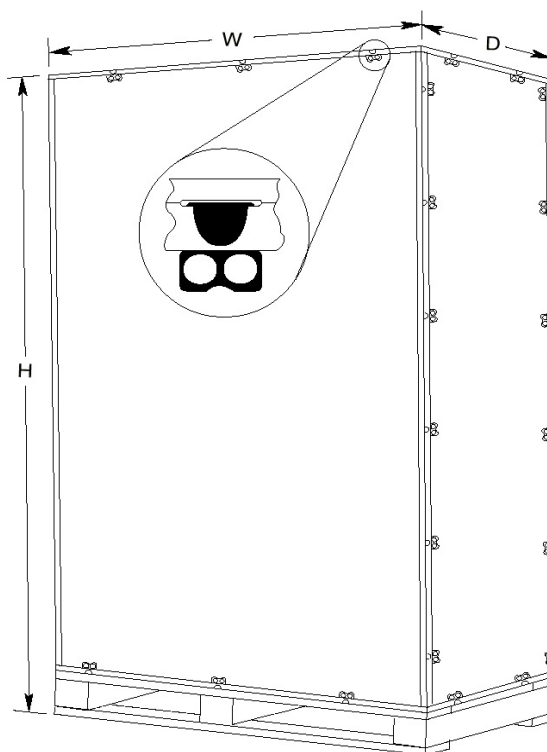

- On IP 00 versions remove the supporting brace bolted to the lifting rings.
- A forklift or similar lifting device should be used at this time to ensure the stability of the VLT frequency converter while the rest of the crate is removed. Position the lifting device to the front side of the crate.
- The VLT frequency converter should be lifted using a spreader bar or other similar lifting device. Lift the VLT frequency converter slightly, using all four lifting rings, distributing the weight as evenly as possible.

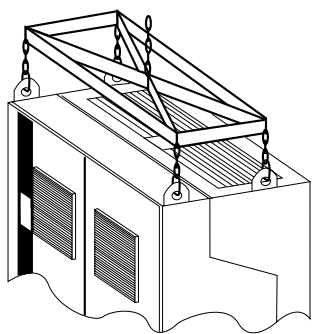

- Remove the metal locking tabs and the remaining crate panels.
- On IP 00 versions remove the clear plastic safety barrier from the front of the unit to prevent the possibility of breaking during positioning of the VLT frequency converter.
- The VLT frequency converter is now ready to be lifted and positioned in the installation site. NOTE: On IP 00 versions there are inductors bolted to the bottom of the crate. Lift the VLT frequency converter high enough to allow clearance over these inductors.
- Observe cooling and ventilation requirements given in the "Installation Site" section of this manual.
- Secure to the floor using the four holes provided in the bottom of the unit. On IP 00 versions secure to the panel using the four mounting holes provided in the back. Refer to the dimensional drawings in this instruction manual.

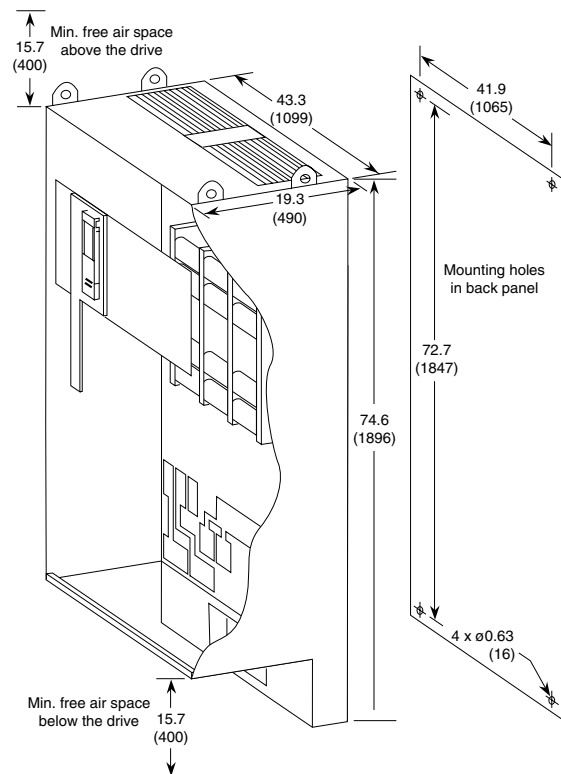
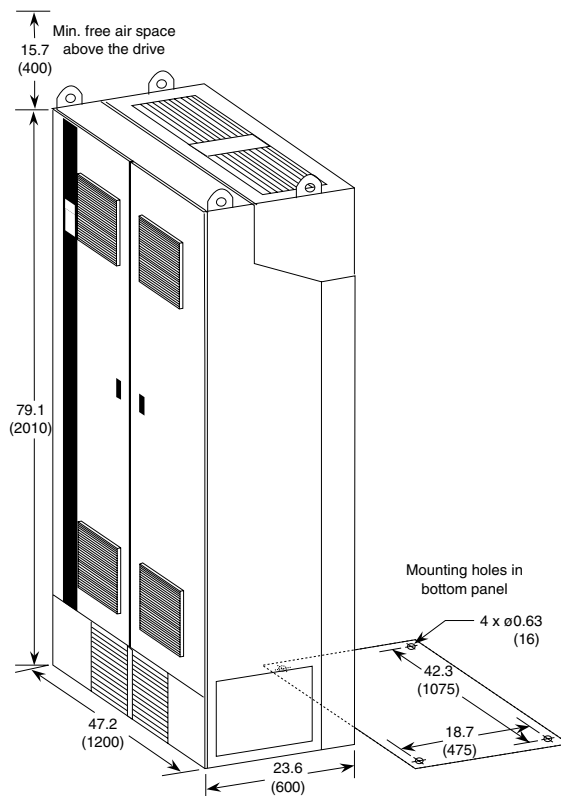

■ Key diagram for VLT 5300-5500 / VLT 6350-6550 / VLT 8350-8550

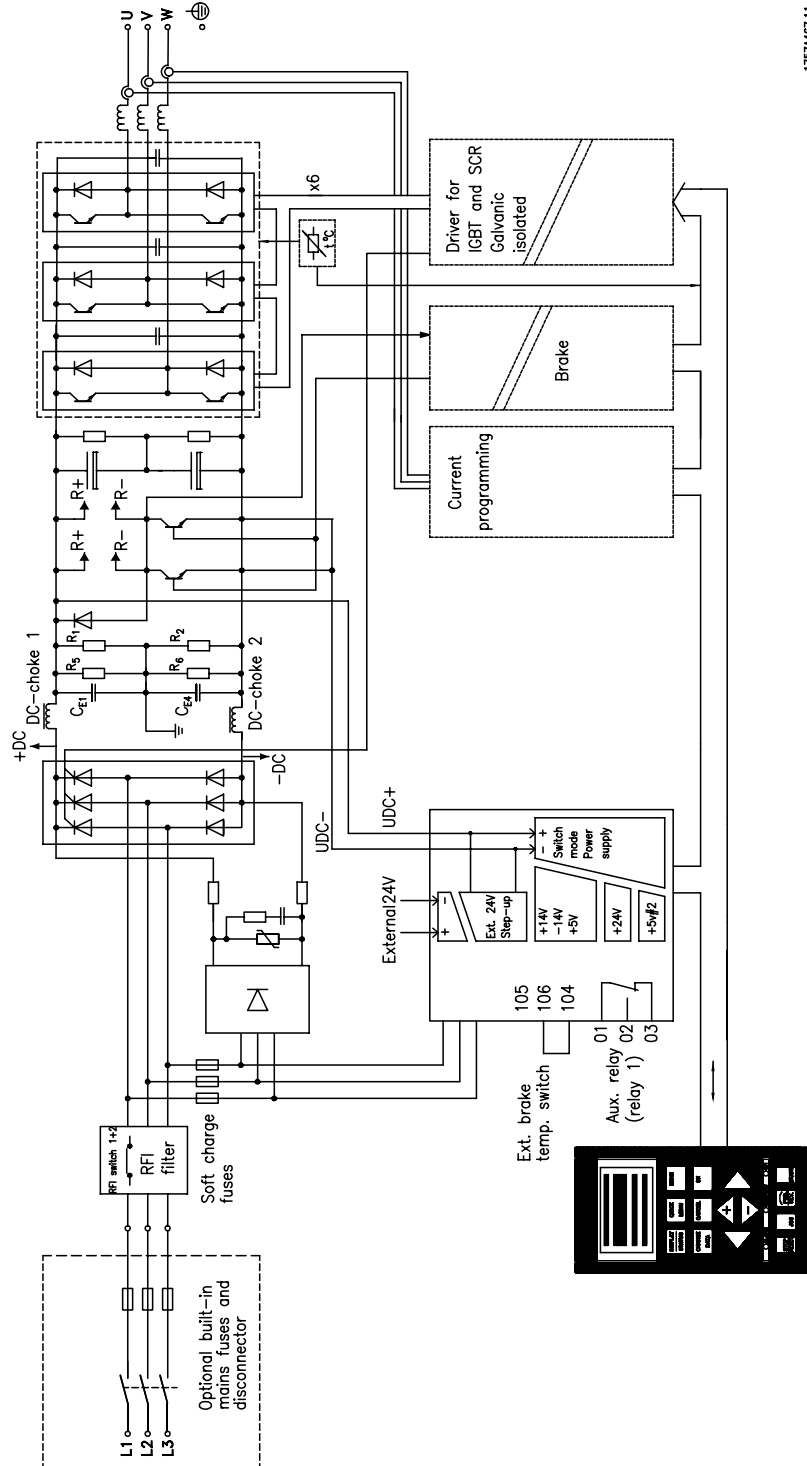

1752467.11

Brake terminals 81, 82 and 104-106 are not available in VLT 6000 HVAC.

■ Compact, Mains supply 3 x 380 - 500 V

According to international requirements		VLT type	5300	5350	5450	5500
Normal overload torque (110 %):						
Output current	$I_{VLT,N}$ [A] (380-440 V)		480	600	658	745
	$I_{VLT,MAX}$ (60 s) [A] (380-440 V)		528	660	724	820
	$I_{VLT,N}$ [A] (441-500 V)		443	540	590	678
	$I_{VLT,MAX}$ (60 s) [A] (441-500 V)		487	594	649	746
Output	$S_{VLT,N}$ [kVA] (380-440 V)		333	416	456	516
	$S_{VLT,N}$ [kVA] (441-500 V)		384	468	511	587
Typical shaft output (380-440 V) $P_{VLT,N}$ [kW]			250	315	355	400
Typical shaft output (380-440 V) $P_{VLT,N}$ [HP]			300	350	450	500
Typical shaft output (441-500 V) $P_{VLT,N}$ [kW]			315	355	400	500
Typical shaft output (441-500 V) $P_{VLT,N}$ [HP]			350	450	500	600
High overload torque (150 %):						
Output current	$I_{VLT,N}$ [A] (380-440 V)		395	480	600	658
	$I_{VLT,MAX}$ (60 s) [A] (380-440 V)		593	720	900	987
	$I_{VLT,N}$ [A] (441-500 V)		361	443	540	590
	$I_{VLT,MAX}$ (60 s) [A] (441-500 V)		542	665	810	885
Output	$S_{VLT,N}$ [kVA] (380-440 V)		274	333	416	456
	$S_{VLT,N}$ [kVA] (441-500 V)		313	384	468	511
Typical shaft output (380-440 V) $P_{VLT,N}$ [kW]			200	250	315	355
Typical shaft output (380-440 V) $P_{VLT,N}$ [HP]			300	350	450	500
Typical shaft output (441-500 V) $P_{VLT,N}$ [kW]			250	315	355	400
Typical shaft output (441-500 V) $P_{VLT,N}$ [HP]			350	450	500	600
Max. cross-section of copper cable to motor, brake and loadsharing (380-440 V) [mm ²] ⁵⁾			2x150 3x70	2x185 3x95	2x240 3x120	2x300 3x150
Max. cross-section of copper cable to motor, brake and loadsharing (441-500 V) [mm ²] ⁵⁾			2x120 3x70	2x150 3x95	2x185 3x95	2x300 3x120
Max. cross-section of aluminium cable to motor, brake and loadsharing (380-440 V) [mm ²] ⁵⁾			2x185 3x120	2x240 3x150	2x300 3x185	3x185
Max. cross-section of aluminium cable to motor, brake and loadsharing (441-500 V) [mm ²] ⁵⁾			2x150 3x95	2x185 3x120	2x240 3x150	3x185
Max. cross-section of copper cable to motor, brake and loadsharing (380-440 V) AWG] ^{2) 5)}			2x250mcm 3x2/0	2x350mcm 3x3/0	2x400mcm 3x4/0	2x500mcm 3x250mcm
Max. cross-section of copper cable to motor, brake and loadsharing (441-500 V) AWG] ^{2) 5)}			2x4/0 3/1/0	2x300mcm 3x3/0	2x350mcm 3x3/0	2x500mcm 3x4/0
Max. cross-section of aluminium cable to motor, brake and loadsharing (380-440 V) AWG] ^{2) 5)}			2x350mcm 3x4/0	2x500mcm 3x250mcm	2x600mcm 3x300mcm	2x700mcm 3x350mcm
Max. cross-section of aluminium cable to motor, brake and loadsharing (441-500 V) AWG] ^{2) 5)}			2x300mcm 3x3/0	2x400mcm 3x4/0	2x500mcm 3x250mcm	2x600mcm 3x300mcm

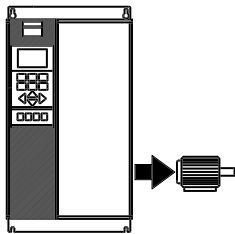

1. For type of fuse see section *Fuses*.
2. American Wire Gauge.
3. Measured using 30 m screened motor cables at rated load and rated frequency.
4. Min. cable cross-section is the smallest cable cross-section allowed to be fitted on the terminals. Always comply with national and local regulations on min. cable cross-section.
5. Connection stud 2 x M12/3 x M12.

■ Compact, Mains supply 3 x 380 - 500 V

According to international requirements	VLT type	5300	5350	5450	5500
Rated input current 110%	$I_{L,MAX}$ [A] (400 V)	467	584	648	734
	$I_{L,MAX}$ [A] (460 V)	431	526	581	668
Rated input current 150%	$I_{L,MAX}$ [A] (400 V)	389	467	584	648
	$I_{L,MAX}$ [A] (460 V)	356	431	526	581
Max. cross-section of copper cable to power (380-440 V) [mm ²] ⁵⁾		2x150 3x70	2x185 3x95	2x240 3x120	2x300 3x150
	Max. cross-section of copper cable to power (441-500 V) [mm ²] ⁵⁾	2x120 3x70	2x150 3x95	2x185 3x95	2x300 3x120
Max. cross-section of aluminium cable to power (380-440 V) [mm ²] ⁵⁾		2x185 3x120	2x240 3x150	2x300 3x185	3x185
	Max. cross-section of aluminium cable to power (441-500 V) [mm ²] ⁵⁾	2x150 3x95	2x185 3x120	2x240 3x150	3x185
Max. cross-section of copper cable to power (380-440 V) [AWG] ^{2) 5)}		2x250mcm 3x2/0	2x350mcm 3x3/0	2x400mcm 3x4/0	2x500mcm 3x250mcm
	Max. cross-section of copper cable to power (441-500 V) [AWG] ^{2) 5)}	2x4/0 3/1/0	2x300mcm 3x3/0	2x350mcm 3x3/0	2x500mcm 3x4/0
Max. cross-section of aluminium cable to power (380-440 V) [AWG] ^{2) 5)}		2x350mcm 3x4/0	2x500mcm 3x250mcm	2x600mcm 3x300mcm	2x700mcm 3x350mcm
	Max. cross-section of aluminium cable to power (441-500 V) [AWG] ^{2) 5)}	2x300mcm 3x3/0	2x400mcm 3x4/0	2x500mcm 3x250mcm	2x600mcm 3x300mcm
Max. pre-fuses (mains) [-]/UL ¹⁾ [A]		630/600	700/700	800/800	800/800
Integral pre-fuses (softcharge circuit) [-]/UL ⁶⁾ [A]		9/9	9/9	9/9	9/9
Integral pre-fuses (snubber resistors) [-]/UL ⁷⁾ [A]		15/15	15/15	15/15	15/15
Integral pre-fuses (SMPS) [-]/UL ⁸⁾ [A]		5.0/5.0	5.0/5.0	5.0/5.0	5.0/5.0
Efficiency		0.97	0.97	0.97	0.97
Weight IP 00	kg (lb)	480 (1058)	515 (1135)	560 (1235)	585 (1290)
Weight Nema 1	kg (lb)	595 (1132)	630 (1389)	675 (1488)	700 (1543)
Weight IP 54	kg (lb)	605 (1334)	640 (1411)	685 (1510)	710 (1565)
Power loss at max. load [W]		7500	9450	10650	12000
Enclosure		IP 00 / Nema 1 (IP 20) / IP 54			

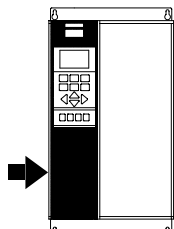

1. For type of fuse see section *Fuses*.
2. American Wire Gauge.
3. Measured using 30 m screened motor cables at rated load and rated frequency.
4. Min. cable cross-section is the smallest cable cross-section allowed to be fitted on the terminals. Always comply with national and local regulations on min. cable cross-section.
5. Connection stud 2 x M12/3 x M12.
6. If UL/cUL is to be complied with, AC Littelfuse type KLK, Danfoss ordering no. 175L3489 must be used.
7. If UL/cUL is to be complied with, DC Littelfuse type KLKD, Danfoss ordering no. 176F1147 must be used.
8. If UL/cUL is to be complied with, Bussmann type KTK-5, Danfoss ordering no. 175L3437 must be used.

■ Mains supply 3 x 380-500 V

According to international requirements

		VLT type	6350	6450	6500	6550
			8350	8450	8500	8550
Output current	$I_{VLT,N}$ [A] (380-415 V)		480	600	658	745
	$I_{VLT,MAX}$ (60 s)[A](380-415 V)		528	660	724	820
	$I_{VLT,N}$ [A] (440-460 V)		443	540	590	678
	$I_{VLT,MAX}$ (60 s)[A](440-460 V)		487	594	649	746
Output	$S_{VLT,N}$ [kVA] (380-415 V)		333	416	456	516
	$S_{VLT,N}$ [kVA] (440-460 V)		384	468	511	587
Typical shaft output (380-415 V) $P_{VLT,N}$ [kW]			250	315	355	400
Typical shaft output (380-415 V) $P_{VLT,N}$ [HP]			300	350	450	500
Typical shaft output (440-460 V) $P_{VLT,N}$ [kW]			315	355	400	500
Typical shaft output (440-460 V) $P_{VLT,N}$ [HP]			350	450	500	600
Max. cross-section of copper cable to motor, brake and loadsharing (380-415 V) [mm ²] ⁵⁾		2 x 150	2 x 185	2 x 240	2 x 300	
		3 x 70	3 x 95	3 x 120	3 x 150	
Max. cross-section of copper cable to motor and loadsharing (440-460 V) [mm ²] ⁵⁾		2 x 120	2 x 150	2 x 185	2 x 300	
		3 x 70	3 x 95	3 x 95	3 x 120	
Max. cross-section of aluminium cable to motor and loadsharing (380-415 V) [mm ²] ⁵⁾		2 x 185	2 x 240	2 x 300		
		3 x 120	3 x 150	3 x 185	3 x 185	
Max. cross-section of aluminium cable to motor and loadsharing (440-460) [mm ²] ⁵⁾		2 x 150	2 x 185	2 x 240		
		3 x 95	3 x 120	3 x 150	3 x 185	
Max. cross-section of copper cable to motor and loadsharing (380-415 V) AWG] ^{2) 5)}		2x250mcm	2x350mcm	2x400mcm	2x500mcm	
		3 x 2/0	3 x3/0	3 x 4/0	3x250mcm	
Max. cross-section of copper cable to motor and loadsharing (440-460 V) AWG] ^{2) 5)}		2 x 4/0	2x300mcm	2x350mcm	2x500mcm	
		3 x 1/0	3 x 3/0	3 x 3/0	3 x 4/0	
Max. cross-section of aluminium cable to motor and loadsharing (380-415 V) AWG] ^{2) 5)}		2x350mcm	2x500mcm	2x600mcm	2x700mcm	
		3 x 4/0	3x250mcm	3x300mcm	3x350mcm	
Max. cross-section of aluminium cable to motor and loadsharing (440-460 V) AWG] ^{2) 5)}		2x300mcm	2x400mcm	2x500mcm	2x600mcm	
		3 x 3/0	3 x 4/0	3x250mcm	3x300mcm	

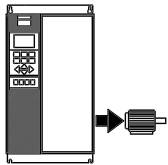

- For type of fuse see section *Fuses*.
- American Wire Gauge.
- Measured using 30 m screened motor cables at rated load and rated frequency.
- Min. cable cross-section is the smallest cable cross-section allowed to be fitted on the terminals. Always comply with national and local regulations on min. cable cross-section.
- Connection stud 2 x M12/3 x M12.
- If UL/cUL is to be complied with, AC Littelfuse type KLK, Danfoss ordering no. 175L3489 must be used.
- If UL/cUL is to be complied with, DC Littelfuse type KLKD, Danfoss ordering no. 176F1147 must be used.
- If UL/cUL is to be complied with, Bussmann type KTK-5, Danfoss ordering no. 175L3437 must be used.

According to international requirements

	VLT type	6350	6450	6500	6550
		8350	8450	8500	8550
Rated input current	$I_{L,N}$ [A] (400 V)	467	584	648	734
	$I_{L,N}$ (460 V)	431	526	581	668
Max. cross-section of copper cable to power (380-415 V) [mm ²] ⁵⁾	2 x 150	2 x 185	2 x 240	2 x 300	
	3 x 70	3 x 95	3 x 120	3 x 150	
Max. cross-section of copper cable to power (440-460 V) [mm ²] ⁵⁾	2 x 120	2 x 150	2 x 185	2 x 300	
	3 x 70	3 x 95	3 x 95	3 x 120	
Max. cross-section of aluminium cable to power (380-415 V) [mm ²] ⁵⁾	2 x 185	2 x 240	2 x 300		
	3 x 120	3 x 150	3 x 185	3 x 185	
Max. cross-section of aluminium cable to power (440-460 V) [mm ²] ⁵⁾	2 x 150	2 x 185	2 x 240		
	3 x 95	3 x 120	3 x 150	3 x 185	
Max. cross-section of copper cable to power (380-415 V) AWG] ^{2) 5)}	2x250mcm	2x350mcm	2x400mcm	2x500mcm	
	3 x 2/0	3 x3/0	3 x 4/0	3x250mcm	
Max. cross-section of copper cable to power (440-460 V) AWG] ^{2) 5)}	2 x 4/0	2x300mcm	2x350mcm	2x500mcm	
	3 x 1/0	3 x 3/0	3 x 3/0	3 x 4/0	
Max. cross-section of aluminium cable to power (380-415 V) AWG] ^{2) 5)}	2x350mcm	2x500mcm	2x600mcm	2x700mcm	
	3 x 4/0	3x250mcm	3x300mcm	3x350mcm	
Max. cross-section of aluminium cable to power (440-460 V) AWG] ^{2) 5)}	2x300mcm	2x400mcm	2x500mcm	2x600mcm	
	3 x 3/0	3 x 4/0	3x250mcm	3x300mcm	
Max. pre-fuses (mains)[-]/UL ¹⁾ [A]	630/600	700/700	800/800	800/800	
Integral pre-fuses (softcharge circuit)[-]/UL ⁶⁾ [A]	9/9	9/9	9/9	9/9	
Integral pre-fuses (snubber resistors)[-]/UL ⁷⁾ [A]	15/15	15/15	15/15	15/15	
Integral pre-fuses (SMPS)	5.0/5.0				
Efficiency	0.97				
Weight IP 00 kg (lb)	480	515	560	585	
	(1058)	(1135)	(1235)	(1290)	
Weight Nema 1 (IP 20) kg (lb)	595	630	675	700	
	(1132)	(1389)	(1488)	(1543)	
Weight IP 54 kg (lb)	605	640	685	710	
	(1334)	(1411)	(1510)	(1565)	
Power loss at max. load [W]	7500	9450	10650	12000	
Enclosure	IP 00 / Nema 1 (IP 20) / IP 54				

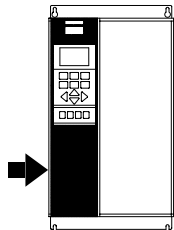

- For type of fuse see section *Fuses*.
- American Wire Gauge.
- Measured using 30 m screened motor cables at rated load and rated frequency.
- Min. cable cross-section is the smallest cable cross-section allowed to be fitted on the terminals. Always comply with national and local regulations on min. cable cross-section.
- Connection stud 2 x M12/3 x M12.
- If UL/cUL is to be complied with, AC Littelfuse type KLK, Danfoss ordering no. 175L3489 must be used.
- If UL/cUL is to be complied with, DC Littelfuse type KLKD, Danfoss ordering no. 176F1147 must be used.
- If UL/cUL is to be complied with, Busmann type KTK-5, Danfoss ordering no. 175L3437 must be used.

■ Mechanical installation

■ Mechanical dimensions

VLT 5300-5500 380-500 Volt, VLT 6350-6550 380-460 Volt and VLT 8350-8550 380-480 Volt

VLT type	A mm (in)	B mm (in)	C mm (in)	ab mm (in)	l/r mm (in)
5300-5500/6350-6550/ 8350-8550 IP 00	1896 (74.65)	1099 (43.27)	494 (19.45)	400 (15.75)	0
5300-5500/6350-6550/ 8350-8550 Nema 1 (IP 20)	2010 (79.13)	1200 (47.24)	600 (23.62)	400 (15.75)	0
5300-5500/6350-6550/ 8350-8550 IP 54	2010 (79.13)	1200 (47.24)	600 (23.62)	400 (15.75)	0

ab: Min. space above enclosure.

l/r: Min. distance between VLT frequency converter and other plant components, left and right sides.

Mechanical installation

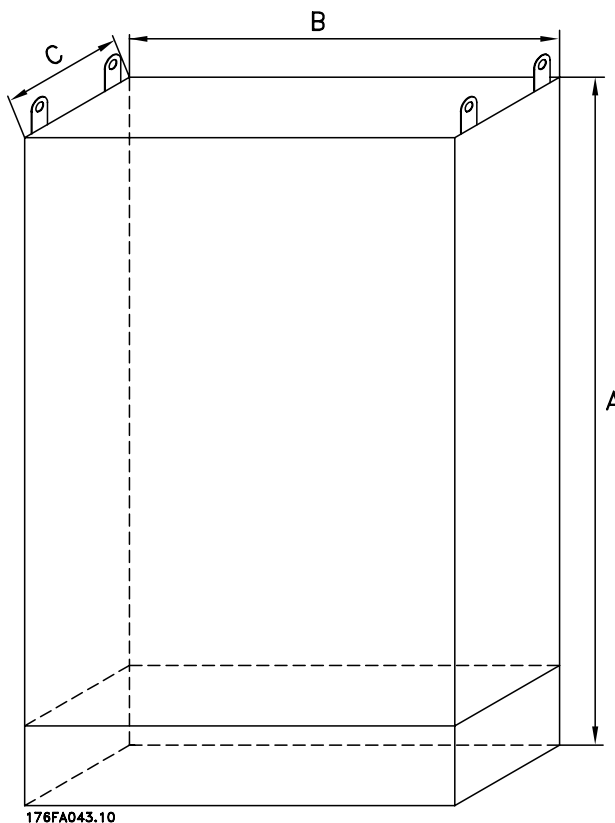

VLT 5300-5500, VLT 6350-6550 and VLT 8350-8550 must be fastened to the floor with bolts. The drawing shows the dimensions.

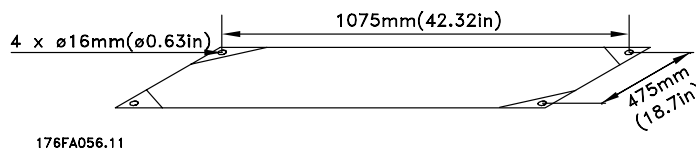

■ **Pre-installation**

The most important part of the mechanical installation is the pre-installation planning. Neglecting this planning may very well result in extra work during and after the installation

Before you install your VLT frequency converter you should select the best possible operational site. Consider the following in the pre-installation plan:

- Ambient operating temperature.
- Installation method.
- The position of the VLT frequency converter.
- The cable routing.
- Ensure that the power source supplies the correct voltage and necessary current.
- If the VLT frequency converter is without built-in mains disconnecter and fuses, ensure that the external disconnecter or fuses have the correct current rating.

■ **Installation site**

The VLT frequency converter must be installed vertically.

The VLT frequency converter is cooled by means of air circulation. For the unit to be able to release its cooling air, the *minimum* distance over the unit must be as shown in the table under *Mechanical Dimension*. To protect the unit from overheating, it must be ensured that the ambient temperature *does not rise above the max. temperature stated for the VLT frequency converter* and that the 24-hour average temperature is not exceeded. The max. temperature and 24-hour average can be seen from the *General Technical Data* in the Operating Instructions. If the ambient temperature is in the range of 45° - 55°C, derating of the VLT frequency converter will become relevant, see *Derating for ambient temperature*.

The service life of the VLT frequency converter will be reduced if derating for ambient temperature is not taken into account.

■ **Installation of VLT 5300-5500 380-500 V, VLT 6350-6550 380-460 V and VLT 8350-8550 380-480 Volt Nema 1 (IP 20) and IP 54 Cooling**

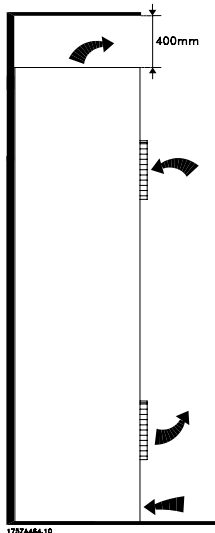

All units in the above-mentioned series require a minimum space of 400 mm (15.75 in) above the enclosure and must be installed on a plane floor. This applies to both Nema 1 (IP 20) and IP 54 units.

Side-by-side

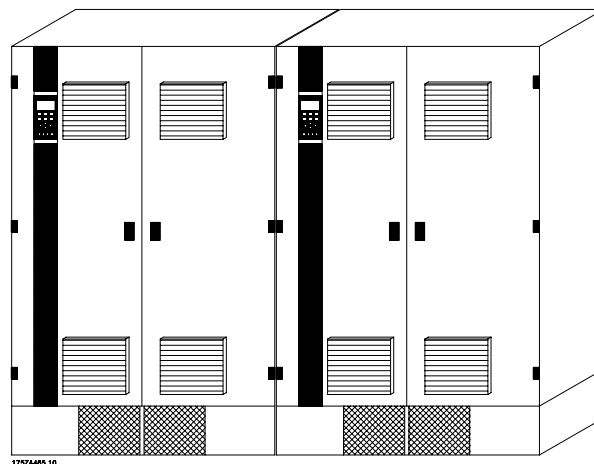

Nema 1 (IP 20) and IP 54

All Nema 1 (IP 20) and IP 54 units in the above-mentioned series can be installed side by side without any space between them, since these units do not require cooling on the sides.

■ Cable site

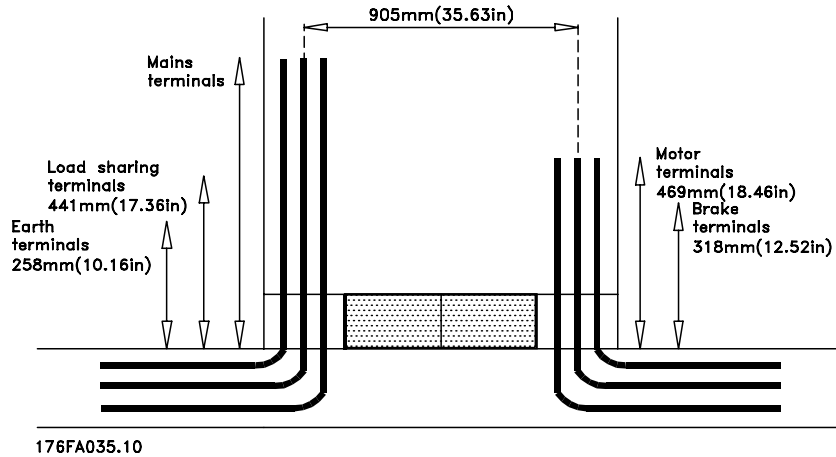

The drawing and table show the mechanical setup of the cable which can be done before the VLT frequency converter is installed.

VLT type	Mains terminal
VLT 5300-5500/6350-6550/8350-8550	969 mm (38.15 in)
VLT 5300-5500/6350-6550/8350-8550 with RFI	516 mm (20.31 in)
VLT 5300/6350/8350 with RFI/Disconnecter	626 mm (24.65 in)
VLT 5350-5500/6400-6550/8350-8550 with RFI/Disconnecter	516 mm (20.31 in)

Mechanical installation

■ Derating for high altitude

Below 1000 m altitude no derating is necessary for VLT 5300-5500, VLT 6350-6550 or VLT 8350-8550.

Above 1000 m the ambient temperature (T_{AMB}) or max. output current ($I_{VLT,MAX}$) must be derated in accordance with the diagram below:

1. Derating of output current versus altitude at $T_{AMB} = \text{max. } 45^{\circ}\text{C}$
2. Derating of max. T_{AMB} versus altitude at 100% output current.

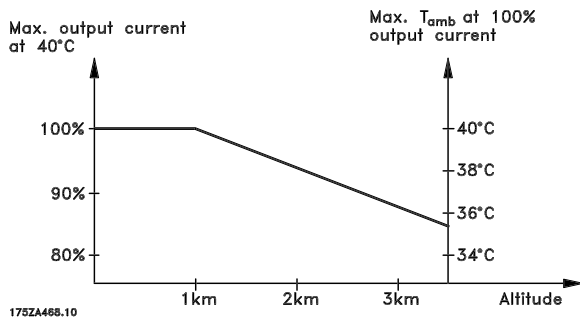

■ Derating for ambient temperature

The ambient temperature ($T_{AMB,MAX}$) is the maximum temperature allowed. The average ($T_{AMB,AVG}$) measured over 24 hours must be at least 5°C lower. If VLT 5300-5500, VLT 6350-6550 or VLT 8350-8550 is operated at temperatures above 45 °C, a derating of the continuous output current is necessary.

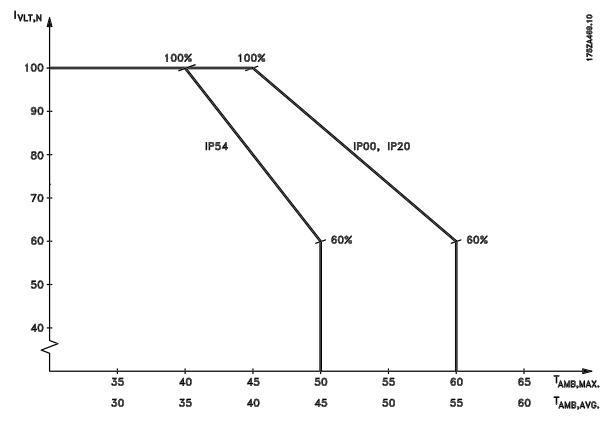

■ Electrical installation



The voltage on the frequency converter is dangerous when the unit is connected to mains.

Incorrect installation of the motor or VLT frequency converter may lead to material damage or serious injury or it may be fatal.

Consequently, the instructions in this manual as well as national and local rules and safety regulations must be complied with. Touching the electrical parts may be fatal, even after the mains supply has been disconnected.

Wait at least 15 minutes if using VLT 5300-5500, VLT 6350-6550 or VLT 8350-8550.



NB!:

It is the user's or certified electrician's responsibility to ensure correct earthing and protection in accordance with applicable national and local norms and standards.

All terminals for the control cables and power cables are located behind the protective cover of the VLT frequency converter. The protective cover can be removed by means of a screwdriver.

Once the protective cover has been removed, the actual EMC-correct installation can start.

■ Pre-fuses

For VLT type 5300-5500, VLT type 6350-6550 and VLT 8350-8550, external pre-fuses must be

installed in the mains supply to the VLT frequency converter or ordered with built-in pre-fuses and a mains disconnect switch.

UL compliance

To comply with UL/cUL approvals, pre-fuses according to the table below must be used.

	Bussmann	SIBA	Littel fuse	Ferraz-Shawmut
5300/6350/8350	FWH-600	206xx32-600	L50S-600	A50-P600
5350/6450/8450	FWH-700	206xx32-700	L50S-700	A50-P700
5450/6500/8500	FWH-800	206xx32-800	L50S-800	A50-P800
5500/6550/8550	FWH-800	206xx32-800	L50S-800	A50-P800

Non UL compliance

If UL/cUL is not to be complied with, we recommend the above mentioned fuses or type gR.

Not following the recommendation may result in unnecessary damage of the drive in case of malfunction. Fuses must be designed for protection in a circuit capable of supplying a maximum of 100000 A_{rms} (symmetrical), 500 V maximum.

■ Earthing

The following basic issues need to be considered when installing a frequency converter, so as to obtain electromagnetic compatibility (EMC).

- Safety earthing: Please note that the frequency converter has a high leakage current and must be earthed appropriately for safety reasons. Apply local safety regulations.
- High-frequency earthing: Keep the earth wire connections as short as possible.

Connect the different earth systems at the lowest possible conductor impedance. The lowest possible conductor impedance is obtained by keeping the conductor as short as possible and by using the greatest possible surface area.

The metal cabinets of the different devices are mounted on the cabinet rear plate using the lowest possible HF impedance. This avoids having different HF voltages for the individual devices and avoids the risk of radio interference currents running in connection cables that may be used between the devices. The radio interference will have been reduced. In order to obtain a low HF impedance, use the fastening bolts of the devices as HF connection to the rear plate. It is necessary to remove insulating paint or similar from the fastening points.

■ RFI switch

Mains supply isolated from earth:

If the VLT frequency converter is supplied from an isolated mains source (IT mains), the RFI switch can be turned off (OFF). In OFF position, the internal RFI capacities (filter capacitors) between the chassis and the intermediate circuit are cut off to avoid damage to the intermediate circuit and to reduce the earth capacity currents (according to IEC 1800-3). See position of RFI switch by *Electrical installation, enclosures*.



NB!:

The RFI switch is not to be operated with mains connected to the unit. Check that the mains supply has been disconnected before operating the RFI switch.



NB!:

Open RFI switch is only allowed at factory set switching frequencies.



NB!:

The RFI switch disconnects the capacitors galvanically; however, transients higher than approx. 1,000 V will be bypassed by a spark gap.

Mains supply connected to earth:

The RFI switch must be in ON position in order for the frequency converter to comply with the EMC-standard.

■ Electrical installation, power cables

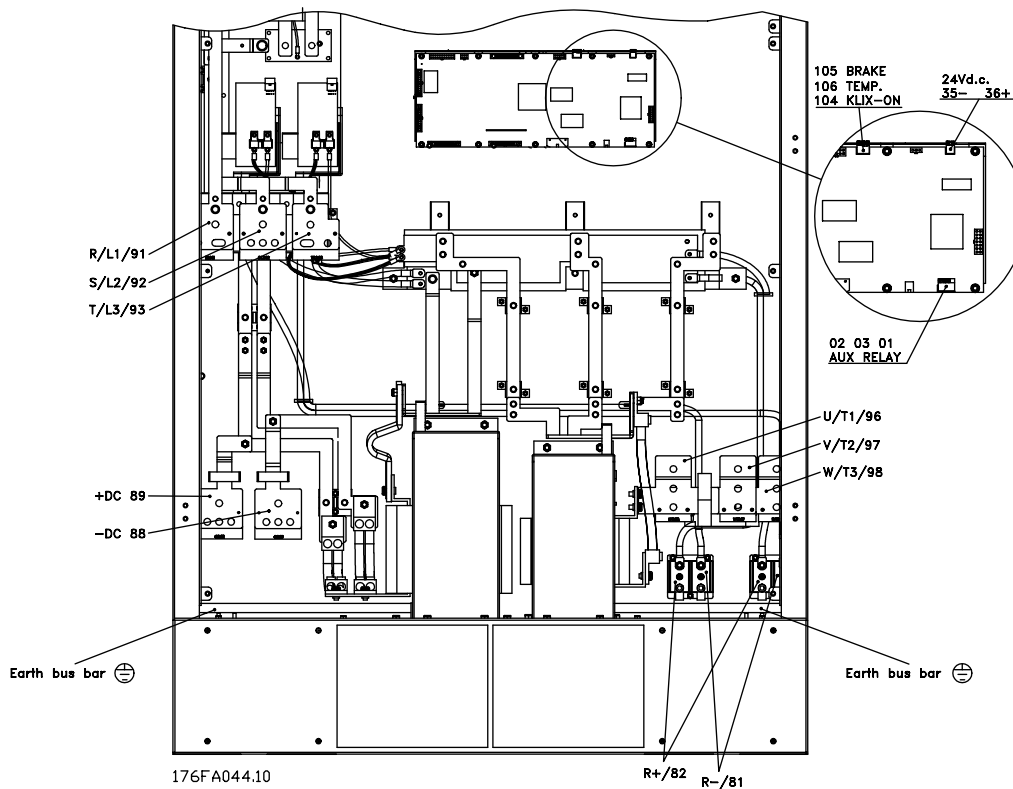

**Compact Nema 1 (IP 20)/IP 54
Without disconnecter and mains fuses**

**VLT 5300-5500
VLT 6350-6550
VLT 8350-8550**

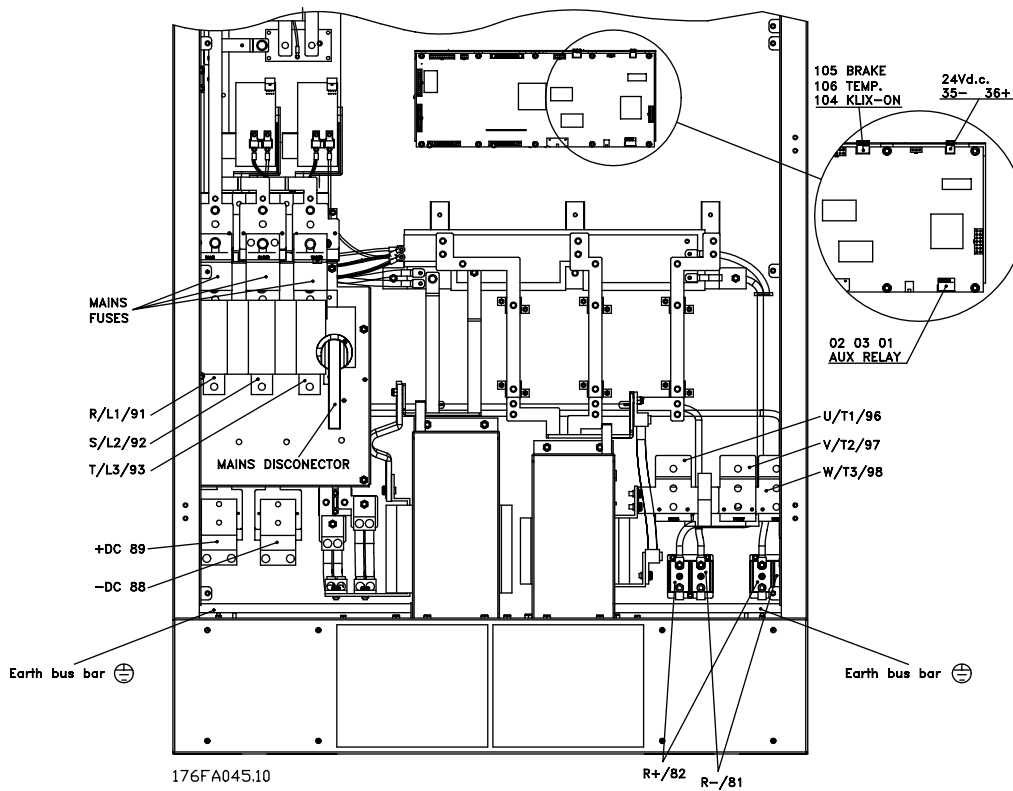

**Compact Nema 1 (IP 20)/IP 54
With disconnecter and mains fuses**

**VLT 5300-5500
VLT 6350-6550
VLT 8350-8550**

Brake terminals 81, 82 and 104-106 are not available in VLT 6000 HVAC.

■ Electrical installation, enclosure

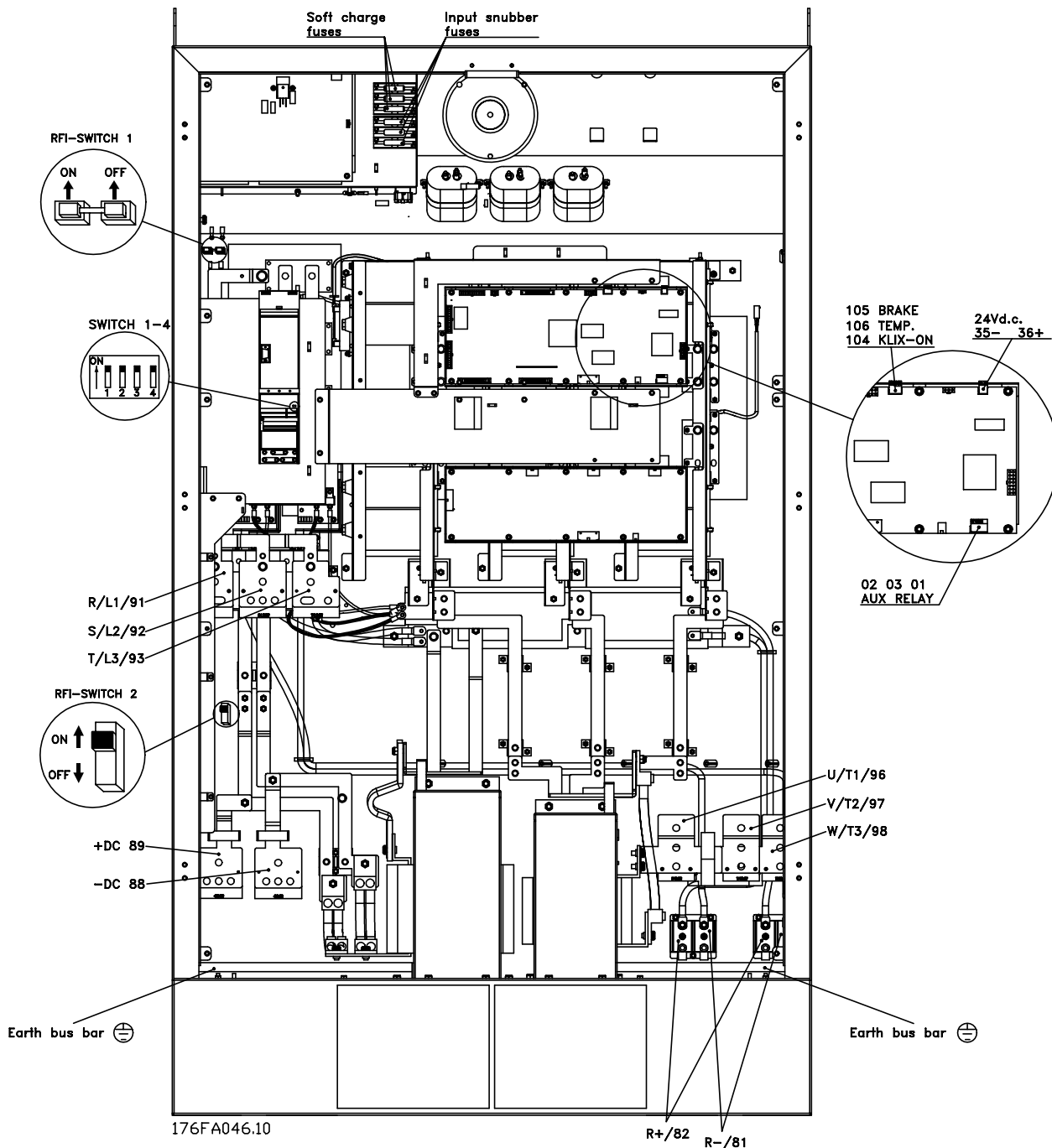

Electrical installation

Compact Nema 1 (IP 20) / IP 54

- VLT 5300-5500
- VLT 6350-6550
- VLT 8350-8550

Brake terminals 81, 82 and 104-106 are not available in VLT 6000 HVAC.

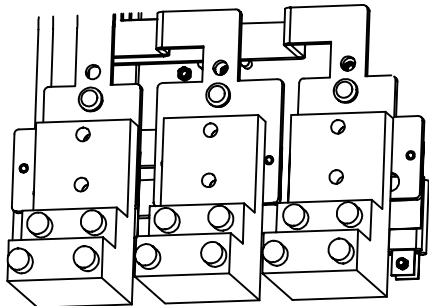
Terminal adapter kit

176FA036.10

The terminal adapter kit is an optional kit for VLT 5300-5500, VLT 6350-6650 and VLT 8350-8550. The terminal adapter kit makes it possible to connect the power wires with the power terminals i.e. the mains-, motor-, load sharing and brake terminals.

The ordering numbers of the terminal adapter kit are:

VLT 5300-5500/6350-6550 EX, DX	176F1815
VLT 5300-5500 EB, DE	176F1816
VLT 8350-8550 EX, DX	175F1815

Tightening-up torques

The table shows the torque required when fitting terminals to the VLT frequency converter. For VLT 5300-5500, VLT 6350-6550 and VLT 8350-8550 the cables must be fastened with bolts or the terminal adapter kit. These figures apply to the following terminals:

Mains terminals	Nos	R, L1, 91 S, L2, 92 T, L3, 93
Motor terminals	Nos	U, T1, 96 V, T2, 97 W, T3, 98
Earth terminal	No	95
Brake resistor terminals		R- 81 R+ 82
Loadsharing		DC- 88 DC+ 89

VLT type	Tightening-up torque	Bolt size
VLT 5300-5500 ¹⁾	42 Nm (31 lb-ft)	M12
VLT 6350-6550	42 Nm (31 lb-ft)	M12
VLT 8350-8550	42 Nm (31 lb-ft)	M12

¹⁾ For the brake terminals, the tightening-up torque is 11.3 (8.33 lb-ft) Nm and the bolt size M8.

Installation of 24 Volt external DC supply

Torque: 0.5 - 0.6 Nm
Screw size: M3

No.	Function
35, 36	24 V external DC supply

24 V external DC supply can be used as low-voltage supply to the control card and any option cards installed. This enables full operation of the LCP (incl. parameter setting) without connection to mains. Please note that a warning of low voltage will be given when 24 V DC has been connected; however, there will be no tripping. If 24 V external DC supply is connected or switched on at the same time as the mains supply, a time of min. 200 msec. must be set in parameter 120 *Start delay*. A pre-fuse of min. 6 Amp, slow-blow, can be fitted to protect the external 24 V DC supply. The power consumption is 15-50 W, depending on the load on the control card.

NB!:

Use 24 V DC supply of type PELV to ensure correct galvanic isolation (type PELV) on the control terminals of the VLT frequency converter.

Installation of brake resistor temperature switch

Torque: 0.5-0.6 Nm
Screw size: M3

No.	Function
106, 104, 105	Brake resistor temperature switch.



NB!:

This function is only available on VLT 5300-5500 units.

If the temperature of the brake resistor gets too high and the KLIXON switch drops out, the VLT frequency converter will stop braking.

The motor will start coasting.

A KLIXON switch must be installed that can either be normally closed' or normally open'. If this function is not used, 106 and 104 must be short-circuited together.

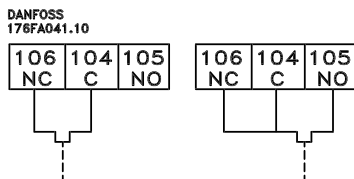

■ Cable cross-section and length

See *Technical data* for correct sizing of motor cable and mains cable cross-section. Always comply with national and local regulations on cable cross-sections. It is important to keep the motor cable as short as possible so as to reduce the noise level and leakage currents to a minimum.

Max. motor cable length for screened cable is 150 m (500 ft.).

Max. motor cable length for unscreened cable is 300 m (1000 ft.).

■ Mains connection

Mains must be connected to terminals R/L1/91, S/L2/92, T/L3/93.



NB!

Check the name plate to ensure that the mains voltage of the VLT frequency converter matches the power supply of your plant.

Ensure that the power supply can supply the necessary current to the VLT frequency converter, see *Technical data*.

If the unit is without built-in mains disconnecter and fuses, ensure that the appropriate disconnecter or fuses have the correct current rating.

See *Technical data* for correct sizing of cable cross-sections.

See *Electrical installation procedures* for how install the mains connections to the VLT frequency converter.

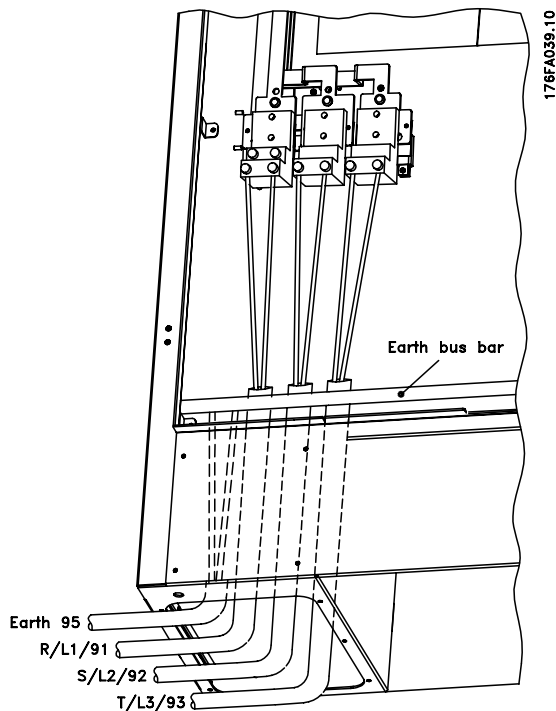

Mains connection from the bottom without built-in disconnecter and fuses

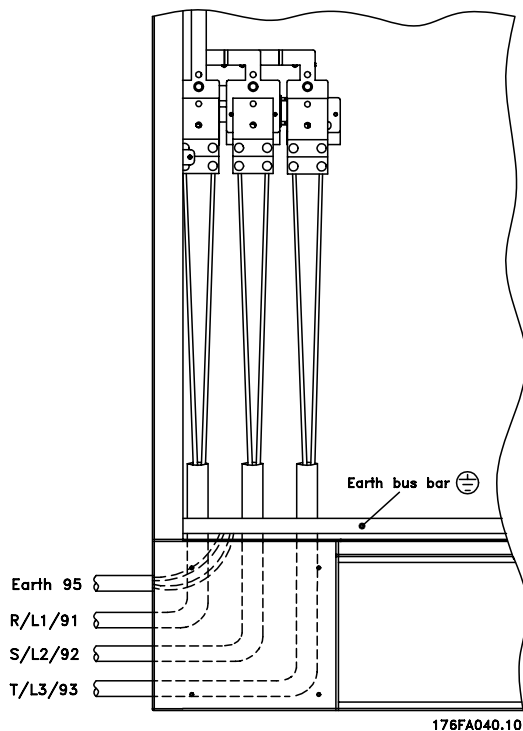

Mains connection from the side without built-in disconnecter and fuses

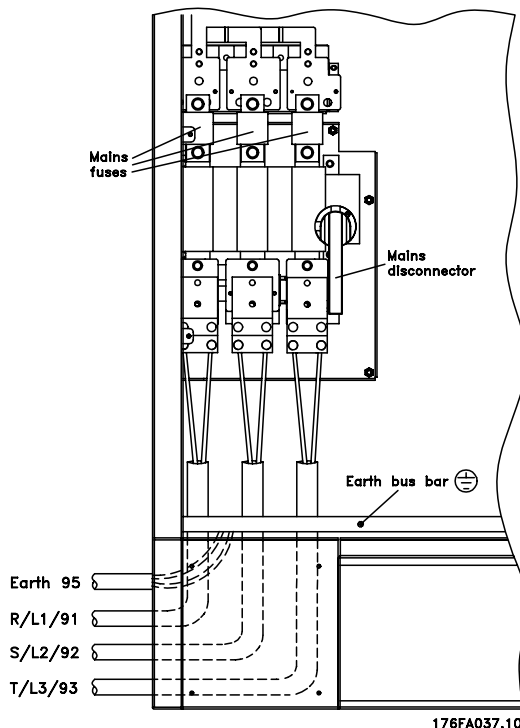

Mains connection from the side with built-in disconnecter and fuses

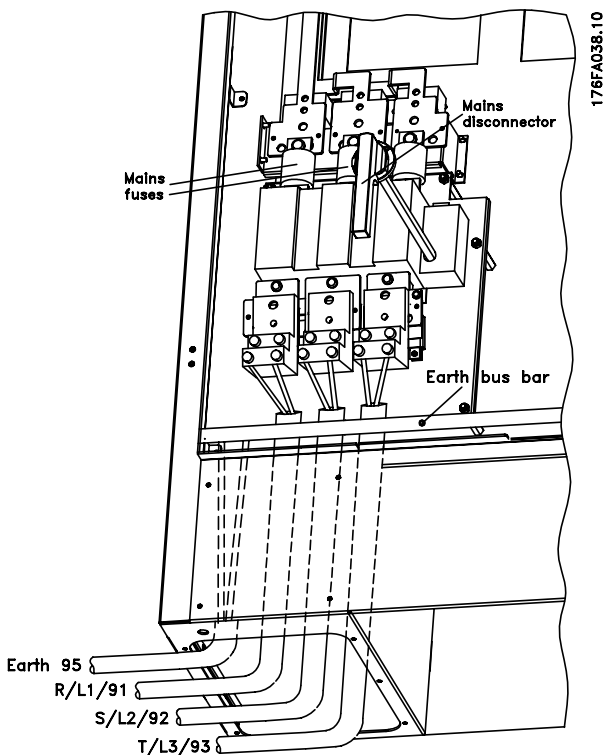

Mains connection from the bottom with built-in disconnecter and fuses

■ Motor connection

The motor must be connected to terminals U/T1/96, V/T2/97, W/T3/98. Earth to terminal 99. All types of three-phase asynchronous standard motors can be used with a VLT frequency converter unit.

The factory setting is for clockwise rotation with the VLT frequency transformer output connected as follows.

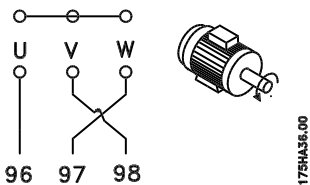
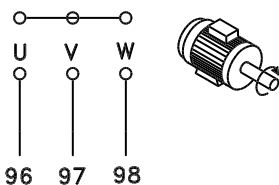

Terminal U/T1/96 connected to U-phase
Terminal V/T2/97 connected to V-phase

Terminal W/T3/98 connected to W-phase

The direction of rotation can be changed by switching two phases in the motor cable.

See *Technical data* for correct sizing of cable cross-sections.

See *Electrical installation procedures* for how install the motor connections to the VLT frequency converter.

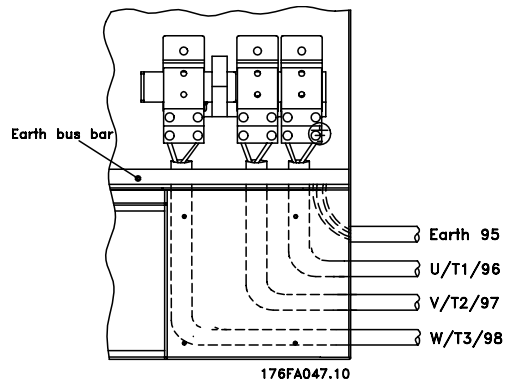

Motor connection from the side

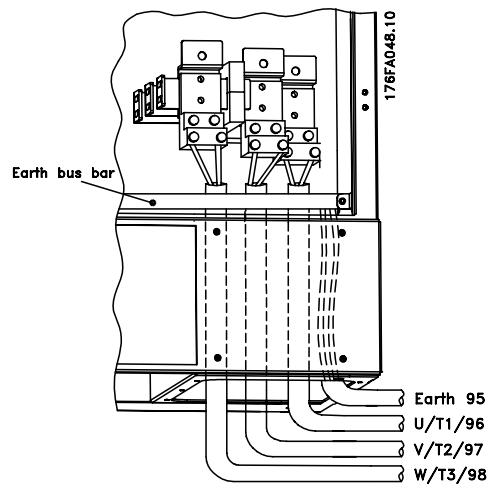

Motor connection from the bottom

■ Brake connection (VLT 5000 Series ONLY)

The connection cable to the brake resistor must be screened. Connect the screen by means of cable clamps to the conductive back plate at the VLT frequency converter and to the metal cabinet of the brake resistor. Size the brake cable cross-section to match the brake torque.



NB!:

Please note that voltages up to 850 V DC may occur on the terminals.

See *Electrical installation procedures* for how install the brake connections to the VLT frequency converter.

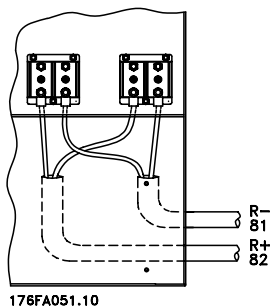

Brake connection from the side

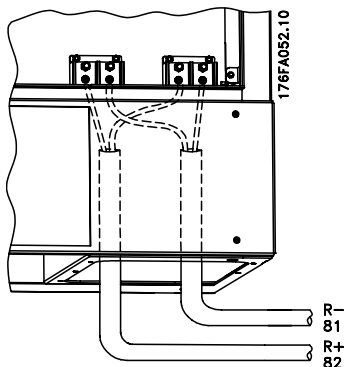

Brake connection from the bottom

■ Load sharing connection

The connection cable must be screened and the max. length from the VLT frequency converter to the DC bar is 25 metres. Load sharing enables linking of the DC intermediate circuits of several VLT frequency converters.



NB!:

Please note that voltages up to 850 V DC will occur on the terminals.

Load sharing calls for extra equipment. For further information please consult Loadsharing Instructions MI.50.NX.XX.

See *Electrical installation procedures* for how install the load sharing connections to the VLT frequency converter.

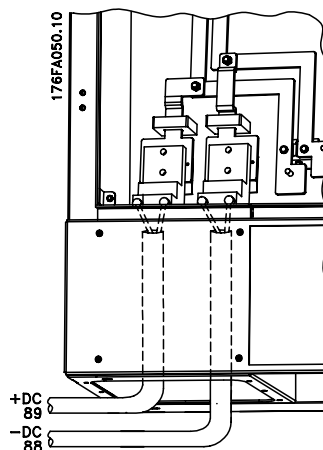
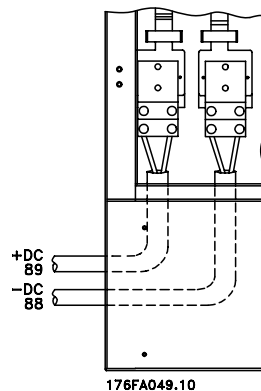

■ **Motor and DC coils connections on IP 00**

IP 00 enclosed VLTs 5300-5500, VLT 6350-6550 and VLT 8350-8550 require installation of the motor and DC coils by the customer. Minimum length of cables are supplied with the VLT frequency converter.

See below drawing for the connection between DC coils and the VLT frequency converter and motor coils and the VLT frequency converter.

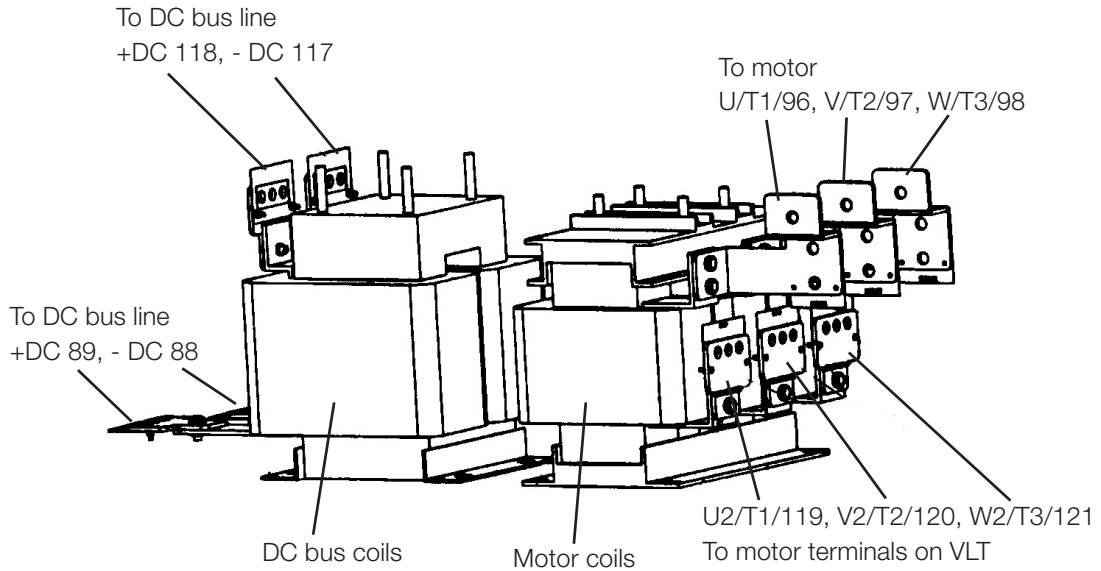

■ Control cable routing

The drawing below shows how to route your control cable in the VLT frequency converter.

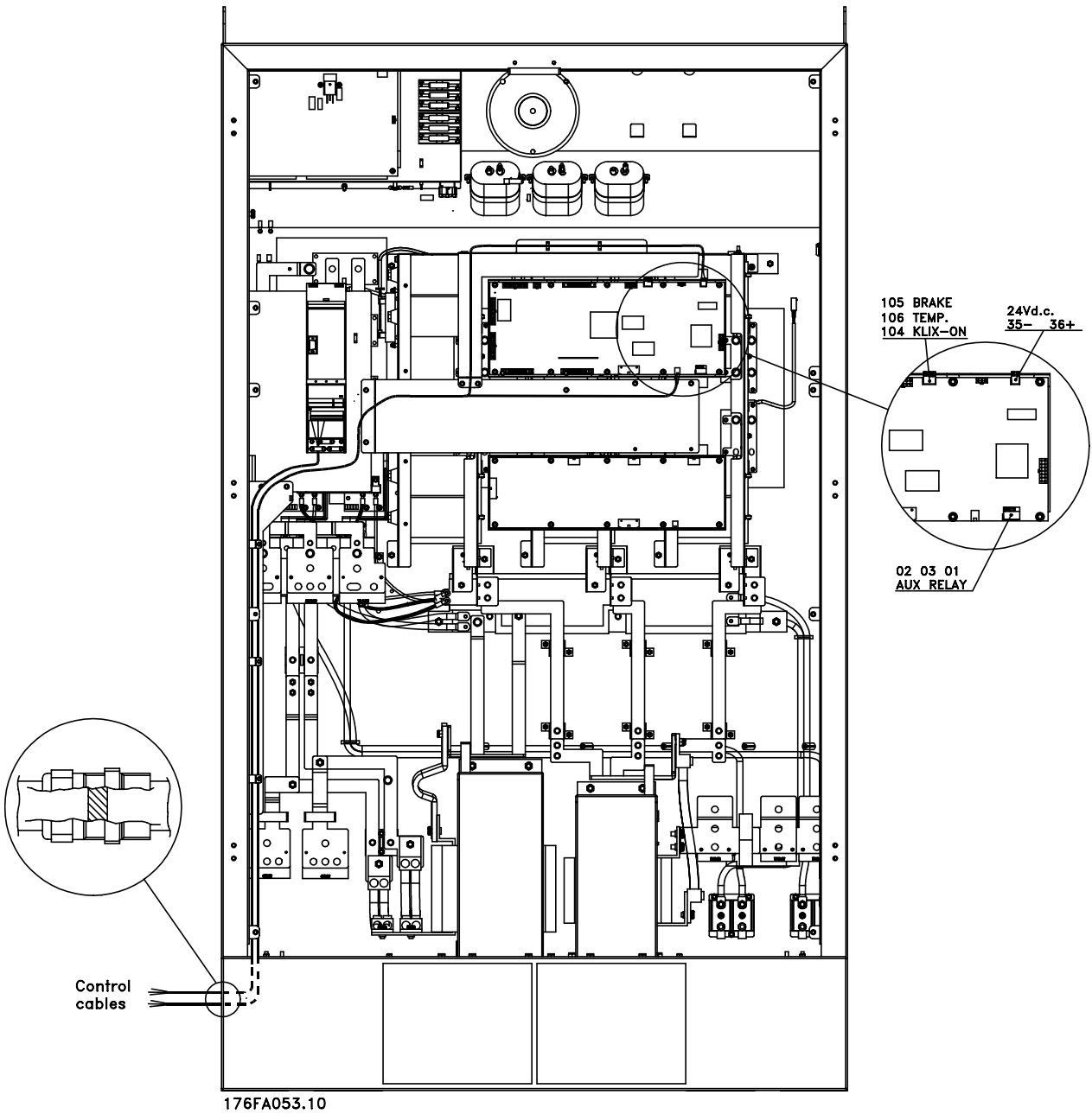

Terminals 104-106 are not available in VLT 6000 and VLT 8000 AQUA series.

■ Connection example

The diagram below gives an example of a typical installation of a VLT frequency converter.

The mains supply is connected to terminals R/L1/91, S/L2/92 and T/L3/93, while the motor is connected to U/T1/96, V/T2/97 and W/T3/98. These numbers can also be seen from the terminals of the VLT frequency converter.

An external DC supply (load sharing) can be connected to terminals 88 and 89.

Analogue inputs can be connected to terminals 53 [V], 54 [V] and 60 [mA]. These inputs can be programmed for either reference, feedback or thermistor. See *Analogue inputs* in parameter group 300.

There are 8 digital inputs, which can be connected to terminals 16-19, 27, 29, 32, 33. These inputs can be programmed in accordance with the table in the Operating instruction. See *Digital inputs* in parameter group 300.

There are two analogue/digital outputs (terminals 42 and 45), which can be programmed to show the present status or a process value, such as 0- f_{max} . Relay outputs 1 and 2 can be used for giving the present status or a warning.

On terminals 68 (P+) and 69 (N-) RS 485 interface, the VLT frequency converter can be controlled and monitored via serial communication.

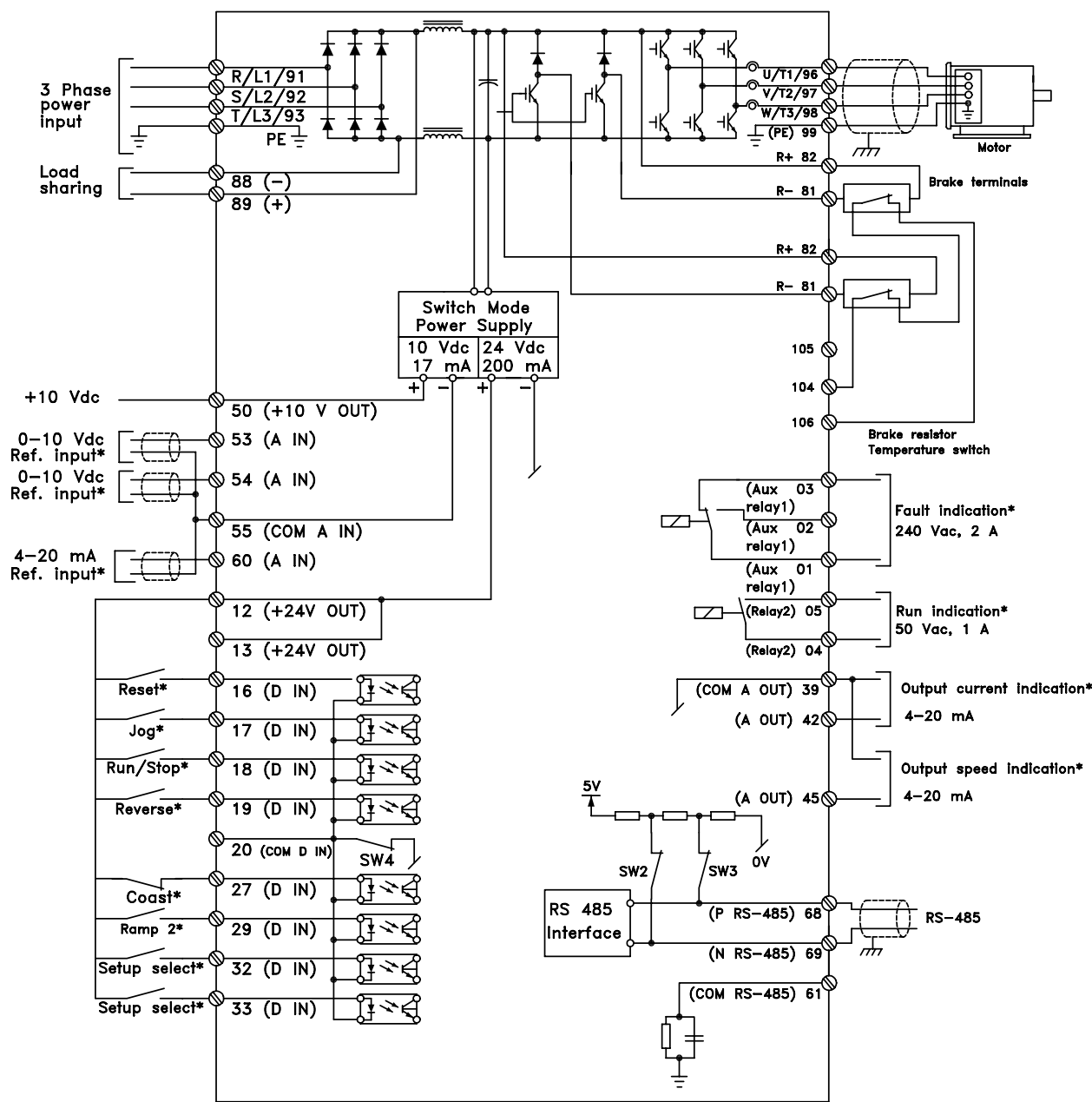

Brake terminals 81, 82 and 104-106 are not available in VLT 6000 and VLT 8000 AQUA series.

* Depends on parameter settings.

■ Electrical installation procedures

The following procedure will guide you through a correct electrical installation of your VLT frequency converter.

Before you start, please read the safety instructions on the first page of this instruction.

Note that the user is responsible, that the VLT frequency converter, motor and other units are installed according to recognized local regulations. Pay special attention to cable dimensioning, pre-fuses, earthing and over-current protection.

1. Mechanical installation check

Check the following before the electrical installation:

1. Check for proper ambient operating conditions.
See Derating for ambient temperature.
2. Check for free flow of cooling air.
3. Check that no visible damage has occurred to the crate and drive during transport and that the tilt indicator on the crate indicates a correct transport.

2. Before electrical installation

Remove the protective cover to get access to terminals for control and power cables. The protective cover can be removed by means of a screwdriver.

3. Load sharing connection

1. Tighten the load sharing terminals with a torque of 42 Nm.
2. Install the wire for DC+ to terminal 89.
3. Install the wire for DC- to terminal 88.



Note that voltages up to 850 V DC will occur on the terminals when power is connected.

4. Mains connection

1. Check that the mains voltage matches the VLT frequency converter nominal input voltage.
2. Ensure that the power supply can supply the necessary current to the VLT frequency converter, see *Technical data*.
3. Tighten the mains and earth terminals with a torque of 42 Nm.
4. Install earth from the power supply to the earth bus bar.
5. Install line 1 from the power supply to terminal R/L1/91.
6. Install line 2 from the power supply to terminal S/L2/92.
7. Install line 3 from the power supply to terminal T/L3/93.

5. Brake resistor (only VLT 5000)

1. Tighten the brake resistor terminals with a torque of 11.3 Nm.
2. Install the wire for R+ to terminal 81.
3. Install the wire for R- to terminal 82.

6. Motor connection

1. Tighten the motor and earth terminals with a torque of 42 Nm.
2. Install earth from the motor to the earth bus bar.
3. Install W from the motor to terminal W/T3/98.
4. Install V from the motor to terminal V/T2/97.
5. Install U from the motor to terminal U/T1/96.

7. Protective cover

Remount the protective cover.

8. Power up

Check the following before you power up the VLT frequency converter:

1. Check for proper mains fuses. See *Technical data*.
2. Check for a proper earthing.
3. Check for proper mains, load sharing, brake and motor connection.
4. Check that there are no tools in the enclosure.

Close the doors and connect the power to the VLT frequency converter. The green voltage indicator lamp (ON) on the control panel is activated when the VLT frequency converter receives voltage.

The VLT frequency converter can now be programmed via the control panel.

Note that in parameter 620 *Operating mode* you can select *Function with de-activated inverter* [1]. This means that without the motor shaft running you can control the influence of the control signal on the control card.



Wait at least 15 minutes before you open the doors, after the VLT frequency converter has been disconnected from mains

■ Electrical installation, control leads

Note: The terminals on the control card are detachable. Connect a jumper between terminals 12 + 24 Volt and 27 Coast.

Mount screened cable to external start/stop of control terminals 12 + 24 Volt and 18 Start.

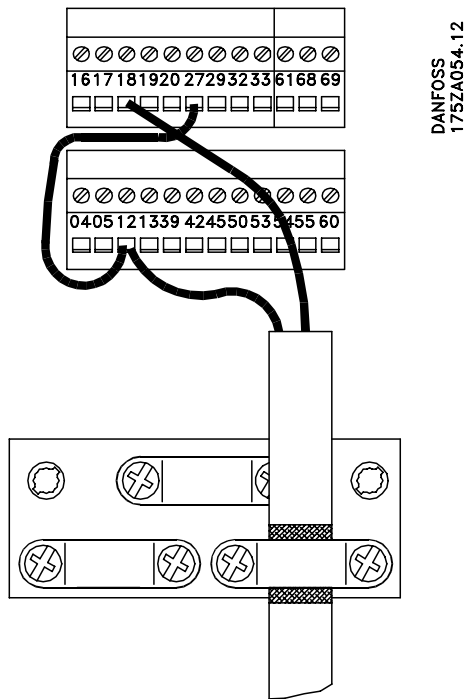

Min. reference	Parameter 204
Max. reference	Parameter 205
Ramp up time	Parameter 207
Ramp down time	Parameter 208

Set Operation site, parameter 002 for Local.

■ Programming the VLT 6000 and VLT 8000 AQUA

The frequency converter is programmed over the control panel.

Press QUICK MENU .

The Quick Menu appears in the display. You choose parameters by means of \uparrow and \downarrow .

Press CHANGE DATA to change parameter value. Data values are changed using \uparrow and \downarrow .

Press \rightarrow or \leftarrow to move the cursor. Press OK to save your parameter setting.

Set the desired language in parameter 001. You have nine possibilities: English, German, French, Danish, Spanish, Italian, Swedish, Dutch and Portuguese.

Set motor parameters according to the motor plate:

Motor power	Parameter 102
Motor voltage	Parameter 103
Motor frequency	Parameter 104
Motor current	Parameter 105
Rated motor speed	Parameter 106

■ Programming the VLT 5000

The frequency converter is programmed over the control panel.

Press QUICK MENU .

The Quick Menu appears in the display. You choose parameters by means of \uparrow and \downarrow .

Press CHANGE DATA to change parameter value. Data values are changed using \uparrow and \downarrow .

Press \rightarrow or \leftarrow to move the cursor. Press OK to save your parameter setting.

Set the desired language in parameter 001. You have six possibilities: English, German, French, Danish, Spanish, Italian.

Set motor parameters according to the motor plate:

Motor power	Parameter 102
Motor voltage	Parameter 103
Motor frequency	Parameter 104
Motor current	Parameter 105
Rated motor speed	Parameter 106

Set frequency interval and ramp times.

Set frequency interval and ramp times.

Min. reference	Parameter 204
Max. reference	Parameter 205
Ramp up time	Parameter 207
Ramp down time	Parameter 208
Relay 1 function	Parameter 323
Relay 2 function	Parameter 326

■ Motor start

Press START on VLT 5000 to start the motor or HAND START on VLT 6000 HVAC to start the motor.

Set motor speed in parameter 003 by VLT 5000.

Set motor speed with the +/- keys on LCP of VLT 6000 and VLT 8000.

Check if the direction of rotation is as shown in the display. It can be changed by swapping two phases of the motor cable.

Press STOP or OFF/STOP to stop the motor.

Select total or reduced Automatic Motor Adaption (AMA) in parameter 107. For further description of AMA, please see the manual.

Press START to start the Automatic Motor Adaption (AMA).

Press DISPLAY/STATUS to leave the Quick Menu.

B		Terminal adapter kit	18
Brake connection (VLT 5000 Series ONLY)	22	Tightening-up torques.....	18
Brake resistor temperature switch	18	Transportation.....	4
C		U	
Cable cross-section	19	Uncrating	4
Cable site	13		
Connection example.....	25		
Control cable routing	24		
Control leads	28		
D			
Derating.....	13		
E			
Earthing	14		
Electrical installation	14		
Electrical installation procedures	27		
External DCsupply	18		
I			
Introduction	3		
K			
Key diagram	6		
L			
Load sharing connection	22		
M			
Mains connection	20		
Mains supply 3 x 380 - 500 V	7		
Mains supply 3 x 380 - 500 V	8		
Mechanical dimensions	11		
Motor connection	21		
Motor start.....	28		
P			
Pre-fuses	14		
Pre-installation	12		
Programming the VLT 5000.....	28		
R			
RFI switch.....	15		
T			