

**Introduction**

|   |   |
|---|---|
| Safety .....                            | 3 |
| Safety Guidelines .....                 | 3 |
| Warnings Against Unintended Start ..... | 3 |
| Introduction .....                      | 4 |
| About this manual.....                  | 4 |
| Assumptions.....                        | 4 |
| References.....                         | 4 |
| Trademarks .....                        | 5 |

**Programming the VLT 6000**

|   |   |
|---|---|
| Control Panel .....                               | 5 |
| Parameter Change Keys .....                       | 5 |
| Local Control .....                               | 6 |
| Quick Menu .....                                  | 6 |
| To Enter or Change Quick Menu Parameter Data..... | 7 |
| Example of Changing Parameter Data.....           | 7 |
| Extended Menu.....                                | 8 |
| HP/kW .....                                       | 8 |

**VLT 6000 Functional Features**

|  |    |
|--|----|
| Drive Operation.....                     | 8  |
| Motor and Drive Thermal Protection ..... | 8  |
| Set-up 1-4.....                          | 8  |
| Current Monitoring and Limits.....       | 9  |
| Direction of Rotation .....              | 9  |
| Start/Stop.....                          | 9  |
| Freeze Mode .....                        | 9  |
| Coast.....                               | 9  |
| Motor Ramp-up and Ramp-down Rate .....   | 9  |
| Lock Panel.....                          | 9  |
| Hand/Auto Modes.....                     | 9  |
| Run Enable.....                          | 9  |
| Bus Functions.....                       | 9  |
| Frequency Out High, Low Limits.....      | 9  |
| Relay Out 1,2 .....                      | 9  |
| PID Control Functions.....               | 10 |
| Sleep Mode .....                         | 10 |
| Drive Control Display .....              | 10 |
| Terminals .....                          | 10 |
| Faults, Warnings and Alarms .....        | 10 |
| Error Status .....                       | 10 |

**VLT 6000 Network Strategies**

|                      |    |
|----------------------|----|
| Strategy One .....   | 11 |
| Strategy Two.....    | 11 |
| Strategy Three ..... | 13 |
| Strategy Four .....  | 13 |



---

## VLT® Adjustable Frequency Drive

---

### VLT 6000 Special Functions

|                               |    |
|-------------------------------|----|
| Safety Interlock .....        | 15 |
| Analog Input Monitoring ..... | 15 |
| Drive Relay Control .....     | 15 |

### Network Connection

|  |    |
|--|----|
| Hardware Setup.....                      | 16 |
| Electrical Control Terminals.....        | 17 |
| Typical Control Connection Examples..... | 18 |

### VLT 6000 Functional Features

|                                   |    |
|-----------------------------------|----|
| Startup of FLN Manual .....       | 20 |
| Faults, Warnings and Alarms ..... | 20 |
| Point Mapping Table .....         | 22 |
| Point Mapping Table Notes.....    | 25 |
| Point Database Definitions.....   | 26 |

### ■ Safety



Rotating shafts and electrical equipment can be hazardous. Therefore, it is strongly recommended that all electrical work conform to National Electrical Code (NEC) and all local regulations. Installation, start-up and maintenance should be performed only by qualified personnel.

Factory recommended procedures, included in this manual, should be followed. Always disconnect electrical power before working on the unit. Although shaft couplings or belt drives are generally not furnished by the manufacturer, rotating shafts, couplings and belts must be protected with securely mounted metal guards that are of sufficient thickness to provide protection against flying particles such as keys, bolts and coupling parts. Even when the motor is stopped, it should be considered “alive” as long as its controller is energized. Automatic circuits may start the motor at any time. Keep hands away from the output shaft until the motor has completely stopped and power is disconnected from the controller.

Motor control equipment and electronic controls are connected to hazardous line voltages. When servicing drives and electronic controls, there will be exposed components at or above line potential. Extreme care should be taken to protect against shock. Stand on an insulating pad and make it a habit to use only one hand when checking components. Always work with another person in case of an emergency. Disconnect power whenever possible to check controls or to perform maintenance. Be sure equipment is properly grounded. Wear safety glasses whenever working on electric control or rotating equipment.

### Safety Guidelines

1. The drive must be disconnected from the AC line before any service work is done.
2. The “Stop/Off” key on the local control panel of the drive does not disconnect the equipment from the AC line and is not to be used as a safety switch.

3. Correct protective grounding of the equipment must be established. The user must be protected against supply voltage and the motor must be protected against overload in accordance with applicable national and local regulations.
4. Ground currents are higher than 3 mA.

### Warnings Against Unintended Start

1. While the drive is connected to the AC line, the motor can be brought to a stop by means of external switch closures, serial bus commands or references. If personal safety considerations make it necessary to ensure that no unintended start occurs, these stops are not sufficient.
2. During programming of parameters, the motor may start. Be certain that no one is in the area of the motor or driven equipment when changing parameters.
3. A motor that has been stopped may start unexpectedly if faults occur in the electronics of the drive, or if an overload, a fault in the supply AC line or a fault in the motor connection or other fault clears.
4. If the “Local/Hand” key is activated, the motor can only be brought to a stop by means of the “Stop/Off” key or an external safety interlock

### NOTE:



It is responsibility of user or person installing drive to provide proper grounding and branch circuit protection for incoming power and motor overload according to National Electrical Code (NEC) and local codes.

The Electronic Thermal Relay (ETR) in UL listed VLTs provides Class 20 motor overload protection in accordance with NEC in single motor applications, when parameter 117 is set for ETR TRIP 1, ETR TRIP 2, ETR TRIP 3, or ETR TRIP 4, and parameter 105 is set for rated motor (nameplate) current.



## **DANGER:**

Touching electrical parts may be fatal - even after equipment has been disconnected from AC line. To be sure that capacitors have fully discharged, wait 14 minutes for 220 and 500 V units and 30 minutes for 550-600 V units after power has been removed before touching any internal component.

### ■ Introduction

The Siemens Floor Level Network (FLN) is a master/slave control network for serial communication with various control devices. The FLN controller is RS-485 compatible, half duplex, with an operating rate of 4800 or 9600 baud. Recommended wiring is shielded, twisted pair. The FLN software protocol is designed to be general in nature to accommodate any unique properties of each device type. The node address system allows up to 96 devices to be used on any one system.

The Danfoss VLT 6000 is a programmable adjustable frequency drive which controls the operation of 3-phase, standard induction electrical motors in the HVAC industry. The VLT 6000 controller has FLN communication protocol software built-in. The drive uses optical isolation for fault tolerance and noise immunity.

The FLN communicates directly with the VLT 6000 drive via the RS-485 serial interface bus. In addition to being able to control the drive, most drive configuration and control parameters can be reviewed and changed through the FLN. Also, the operational status of the drive can be read and monitored through the bus. Diagnostic and operational information stored in the VLT 6000 is easily available, such as kWh of energy used, total operation hours, drive status, motor speed, and many other useful items which can be accessed and monitored through the FLN.

The FLN is designed to communicate with any controller node that supports the interfaces defined in this document.

### About This Manual

The documentation in this manual provides comprehensive information on the connection, programming, and start-up of the VLT 6000 for use with the FLN. It is intended as both an instruction and reference manual. Functions and features of the VLT 6000 adjustable frequency drive are also briefly reviewed to serve as a guideline to optimize your communication system. Read this manual before programming since important information is provided in each section.

For detailed information on using the VLT 6000, see the *VLT 6000 Operating Instructions*.

### Assumptions

This manual assumes that the controller node supports the interfaces in this document and that all the requirements and limitations stipulated in the controller node and the VLT 6000 are strictly observed. It is assumed that the user understands the general capabilities and limitation of the controller node and the VLT 6000 adjustable frequency drive.

### References

*Installation, Operation and Maintenance Manual for the VLT® 6000 Adjustable Frequency Drive*, Danfoss Graham document 23-6108-00.

(Referred to as the *VLT 6000 Operating Instructions* in this manual.)

*Operating Instructions VLT 6000 HVAC Frequency Converter*, Danfoss document MG.60.AX.YY (International version of the *VLT 6000 Operating Instructions*.)

Contact Siemens for operational instructions for the Floor Level Network.

### Trademarks

FLN® is a Siemens registered trademark.

VLT® is a Danfoss registered trademark.

### ■ Programming the VLT 6000

The VLT 6000 adjustable frequency drive is delivered for installation and setup with the required application parameters already programmed at the factory. Specific motor nameplate data may have to be entered at the time of setup. The instructions in this section are intended to provide a general understanding of programming procedures and to enter Quick Menu setup data. See the *VLT 6000 Operating Instructions* for detailed information.



#### NOTE:

Quick menu data for commissioning drive cannot be entered via FLN serial bus.

### Control Panel

The Local Control Panel (LCP), see Figure 1, is a complete interface for programming and operating the drive. The control panel can be removed from the drive and installed up to 3 meters (10 feet) away using the remote mounting kit.

The control panel has five functions:

- Display
- Keys for changing the display
- Keys for changing programming parameters
- Keys for controlling drive operation
- Indicator lamps

The LCP uses a four-line, alpha-numeric LCD display. The display can show four operating data values and three operating condition values continuously. During programming, all the information required for quick, effective parameter setup of the drive is displayed. All drive parameters can be changed from the control panel. Three lamps indicate power on (ON), warning (WARNING) and alarm (ALARM).

### Parameter Change Keys

The LCP keys are divided into groups by function. The keys above indicator lamps are used for parameter setup, selecting the display indication

during normal operation, and controlling the drive speed during local speed control operation.

The keys below the indicator lamps are used for Start/Stop control, selection of the operating location, and reset.

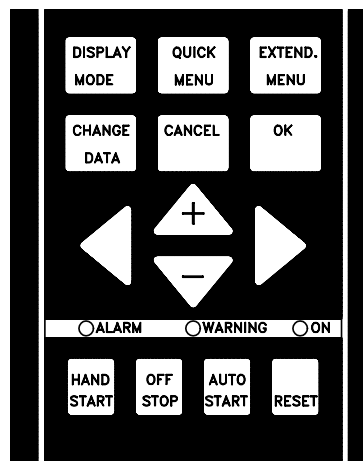

DANFOSS  
175ZA544.10

Figure 1 VLT 6000 Keypad

DISPLAY  
MODE

The DISPLAY MODE key is used to change a display mode or to return to the Display Mode from either the Quick Menu or the Extend Menu mode.

QUICK  
MENU

The QUICK MENU key gives access to the parameters available for the Quick Menu setup. Parameters in this menu are the 12 most important setup parameters for the drive.

EXTEND  
MENU

The EXTEND.MENU key gives access to all parameters.

CHANGE  
DATA

The CHANGE DATA key is used for changing the value of a selected parameter. To change data, the desired parameter is first selected. The CHANGE DATA key is then pressed to enable editing of the parameter. An underline in the display will move under the parameter's value to show that it is being edited.

## VLT® Adjustable Frequency Drive



The CANCEL key is used if a change of the selected parameter is not to be carried out.



The OFF/STOP key is used for stopping the connected motor in either the Hand or Auto Mode. Enable or disable this function via parameter 013, *OFF/START on LCP*. If this stop function is activated, the second line in the LCD display will flash.



The OK key is used to activate a change to the selected parameter.

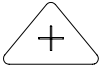

The + and - keys are used to scroll through parameters and to increase or decrease the value of a chosen parameter. The keys are also used to change the local reference. In Display Mode, the keys are used to switch between readouts.

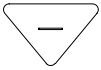

AUTO START is used if the drive is to be started via FLN serial communication and/or the digital control terminals. When a remote start signal is received, the drive will start if the AUTO START key has been pressed.

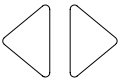

The ◀ and ▶ keys are used to select a parameter group and also to move the cursor to the desired digit when changing numerical values.



### NOTE:

AUTO START key must be pressed to enable starting drive from FLN serial bus or remote terminals.

### Local Control



Start signal via digital inputs may cause drive to start at any time. Remove power to drive before working on output wiring, motor or any driven equipment.

Below the indicator lamps on the LCP are keys used to determine control of the drive. Each key can be individually enabled or disabled using parameters 012 through 015. The Hand Start and Auto Start keys are disabled if any of the control terminals are programmed for either Remote Hand or Remote Auto.



RESET is used for manually resetting the drive after an alarm (fault trip). In this case, the top line of the display shows TRIP (RESET). If the top line of the display shows TRIP (AUTO START), the drive will automatically restart. If the top line of the display shows TRIPLOCK (DICS.MAINS), input power to the drive must be removed before the trip can be reset.



The HAND START key is used to start the drive from the control panel. Pressing HAND START issues a start command to the drive.



If a minimum speed is set in parameter 201, Output Frequency Low Limit, motor will start and ramp up to this frequency when HAND START key is pressed. If drive is already running in Auto Mode when HAND START is pressed, drive will begin running in Hand Mode and in local control.

### Quick Menu

The QUICK MENU key gives access to 12 of the most important setup parameters of the drive. After Quick Menu programming, in many cases the drive will be ready for operation. The 12 Quick Menu parameters are shown in Table 1. Refer to the *VLT 6000 Operating Instructions* for a complete description of the functions.

**Table 1** Quick Menu Items Description

| Quick Menu Item Number | Parameter Name          | Description  |
|------------------------|-------------------------|--|
| 1                      | 001 Language            | Selects language used for all displays.  |
| 2                      | 102 Motor Power         | Sets output characteristics of drive based on kW (HP) of motor. See Table 2 to convert HP to kW.                                 |
| 3                      | 103 Motor Voltage       | Sets output characteristics of drive based on voltage of motor.  |
| 4                      | 104 Motor Frequency     | Sets output characteristics of drive based on nominal frequency of motor. This is typically equal to line frequency.             |
| 5                      | 105 Motor Current       | Sets output characteristics of drive based on full load current in amps (FLA) of motor. This sets overload protection for motor. |
| 6                      | 106 Motor Nominal Speed | Sets output characteristics of drive based on nominal full load speed of motor.  |
| 7                      | 201 Minimum Frequency   | Sets minimum controlled frequency at which motor will run.   |
| 8                      | 202 Maximum Frequency   | Sets maximum controlled frequency at which motor will run.   |
| 9                      | 206 Ramp Up Time        | Sets time to accelerate motor from 0 Hz to nominal motor frequency set in Quick Menu Item 4.                                     |
| 10                     | 207 Ramp Down Time      | Sets time to decelerate motor from nominal motor frequency set in Quick Menu Item 4 to 0 Hz.                                     |
| 11                     | 323 Relay 1 Function    | Sets function of high voltage Form C relay.  |
| 12                     | 326 Relay 2 Function    | Sets function of low voltage Form A relay.   |



During programming of parameters, motor may start. Be certain no one is in area of motor or driven equipment when changing parameters.

5. Press Cancel key to disregard change, or press OK key to accept change and enter new setting.
6. Press Display key to return to normal display.

**To Enter or Change Quick Menu Parameter Data**

Enter or change parameter data or settings in accordance with the following procedure.

1. Press Quick Menu key.
2. Use '+' and '-' keys to find parameter you chose to edit.
3. Press Change Data key.
4. Use '+' and '-' keys to select correct parameter setting. To move to a different digit within parameter, use ◀ and ▶ arrows. *Flashing underline indicates digit selected to change.*

**Example of Changing Parameter Data**

Assume parameter 206, *Ramp Up Time*, is set at 60 seconds. Change the ramp up time to 100 seconds in accordance with the following procedure.

1. Press Quick Menu key.
2. Press "+" key until you reach Parameter 206, *Ramp Up Time*.
3. Press Change Data key.
4. Press ◀ key twice – hundreds digit will flash.
5. Press "+" key once to change hundreds digit to '1.'
6. Press ▶ key once to move cursor to tens digit.

7. Press “-” key until ‘6’ counts down to ‘0’ and setting for *Ramp Up Time* reads ‘100 s.’
8. Press OK key to enter new value into drive controller.
9. Press Display key to return to normal display.

### Extended Menu

In some applications, the Quick Menu items will not set up all the desired characteristics of the drive. To access all VLT 6000 parameters, including the Quick Menu parameters, press the Extend Menu key.



#### NOTE:

Programming of parameter functions available through Extended Menu is done in accordance with same procedure as described for Quick Menu functions.

### HP/kW Conversion

A conversion index for determining kW and HP ratings is shown in Table 2.

**Table 2** HP to kW Conversion Index

| kW   | HP   | kW  | HP  |
|------|------|-----|-----|
| 0.25 | 0.33 | 45  | 60  |
| 0.37 | 0.5  | 55  | 75  |
| 0.55 | 0.75 | 75  | 100 |
| 0.75 | 1.0  | 90  | 125 |
| 1.1  | 1.5  | 110 | 150 |
| 1.5  | 2.0  | 132 | 175 |
| 2.2  | 3.0  | 160 | 200 |
| 3.0  | ---  | 200 | 300 |
| 4.0  | 5.0  | 250 | --- |
| 5.5  | 7.5  | 300 | --- |
| 7.5  | 10   | 315 | 350 |
| 11   | 15   | 355 | 450 |
| 15   | 20   | 400 | 500 |
| 18.5 | 25   | 450 | 600 |
| 22   | 30   |     |     |
| 30   | 40   |     |     |
| 37   | 50   |     |     |

### ■ VLT 6000 Functional Features

The FLN protocol built into the VLT 6000 adjustable frequency drive allows programming of numerous features and monitoring of the drive via the serial bus and the standard RS-485 port. The VLT 6000 also has the capability to control closed or open loop systems on its own and has been designed specifically for HVAC applications. Always accessible in real-time are the system status, what the motor and drive are doing, and if there are any problems. The VLT 6000 continuously monitors all aspects of motor and drive status and issues alarms or warnings for adverse conditions.

The FLN interacts with the drive based upon a point map database and the selected interface strategy. Many, but not all, drive features are accessible through the point map. See the *VLT 6000 Operating Instructions* for more drive details. Table 8 lists the map points and Table 9 supplies definitions. Below is a review of some frequently used drive features and the associated point map numbers.

### Drive Operation (03-14)

These points provide the FLN with operational status information such as output frequency, motor current, output voltage, power and energy. The run time in hours that power has been supplied to the motor is also stored for display, along with cumulative energy used in kWh.

### Motor and Drive Thermal Protection (15, 16, 18)

The motor and drive are protected against thermal overload. The percentage of thermal load is displayed. Point 18 indicates if either the motor or drive thermal limit has been exceeded.

### Set-up 1 - 4 (17) (29)

The drive is capable of maintaining four independent program set-ups. Each set-up supports independent point map configurations. Seasonal changes, various acceleration or deceleration rates, or other operation modes can be accommodated. Point 17 indicates which setup is active. The set-up change is programmed through the drive's keypad or digital I/Os. Day/night operation is implemented in the point map (29) but is not used in this application.



**Current Monitoring and Limits (19, 30)**

The maximum current that the drive provides to the motor can be limited. This tends to limit the torque that can be produced by the motor. Data point 30 sets the current limit in amps, while data point 19 indicates if the motor is operating at that current limit.

**Direction of Rotation (21-22)**

The drive responds to serial commands to reverse direction of the motor. The drive can safely reverse motor rotation while in operation. Many applications benefit from this ability, such as vane axial fans reversed for smoke extraction or cooling towers for deicing. Parameter 506, *Reversing*, must be set to serial communication for point 22 to command the feature.

**Start/Stop (23, 24)**

To run the drive from the FLN or in Auto mode from the drive's digital control terminals, a start command must be given at data point 24. When a stop command is given at this point, the drive will only run in Hand mode.

**Freeze Mode (25, 26)**

If desired, the frequency of the drive can be frozen at its present value. The mode is indicated by data point 25. It is an option available when serial interface is lost.

**Coast (27, 28)**

The coast command (28) shuts down the inverter and makes the motor freewheeling, which normally brings it to stand still. The drive cannot be restarted in any mode before the coast command is removed. It is, therefore, often used as a safety interlock. Data point 27 indicates when the drive is coasted.

**Motor Ramp-up and Ramp-down Rate (31, 32)**

The time to accelerate or decelerate the drive between 0 Hz and the motor's nominal frequency can be programmed. The drive is capable of settings between one to 3600 seconds (one hour).

**Lock Panel (33)**

The local control panel on the VLT 6000 drive can be locked to ensure that program data or drive control functions cannot be changed locally. The Stop button on the keypad will also be locked out and be

incapable of stopping the drive. The serial interface continues to access drive settings.

**Hand/Auto Modes (34)**

The SEL HND.AUTO shows which mode the drive is in. The drive can be commanded into either Hand or Auto mode by pressing the respective keys on the keypad of the drive. Hand mode disables any programmed control strategies and allows the drive keypad to be used to set the drive speed. The only serial communication command that can override Hand mode is data point 28, CMD COAST.

**Run Enable (35)**

Set data point 35 to ON to run the drive from the FLN with default drive parameter settings. In the OFF mode, the drive will run only in Hand mode or in Auto mode from the drive's digital control terminals. Parameter 505, *Start*, controls the interaction of point 35 and the digital run command.

**Bus Functions (36, 37)**

The amount of time the drive will wait between communication packets is programmable. If the time is exceeded, the drive will assume serial communication has stopped and respond with programmable choices. The drive can ignore the loss, freeze its current output, stop, run at a predetermined jog frequency, run at maximum output frequency or stop and trip while issuing an alarm. Wait time is selected at point 36 and the function after a timeout at point 37. See descriptions for parameters 565, *FLN Bus Time Interval* and 566, *FLN Bus Time Interval Function* in the *VLT 6000 Operating Instructions*.

**Frequency Out High, Low Limits (38, 39)**

Limits to the maximum and minimum drive output frequency are programmable. For example, pump manufacturers typically recommend not to operate pumps below a certain speed (for example, 15 Hz) to avoid seal problems.

**Relay Out 1, 2 (40, 41, 43, 44)**

Two programmable relay outputs (one Form C, 240 VAC, 2 Amp; and one Form A, 30 VAC, 1 Amp) are available. These can be triggered through the serial bus by command points 40 and 41. This allows the FLN to utilize the drive's built-in relays as additional network programmable relays. The data points 43 and 44 indicate whether the relay is triggered or not



## VLT® Adjustable Frequency Drive

(On/Off). Parameters 323 and 326, *Relay 1* and *Relay 2 Output Function*, must be set to CONTROL WORD 11/12.

### PID Control Functions (42, 61-65, 68-74)

The VLT 6000 has a sophisticated built-in proportional, integral, derivative (PID) controller. The PID controller is activated by setting parameter 100, *Configuration*, to *Closed loop* through the drive's keypad.

The PID controller in the VLT 6000 supports two feedback values and two setpoints. The feedback can be received in the form of network bus signals and/or standard 0-10 V transmitters. The 2 setpoint controller is capable of controlling return fans based on a fixed differential flow, secondary pumping systems, and so on. This can be used to supplement the BMS system to save on points or capacity. For details on use of the two feedback/setpoint feature, refer to the *VLT 6000 Operating Instructions*. Data points 43 and 44 show the status of an FLN command to the drive.

The points PI GAIN and PI TIME are gain parameters similar to the P and I gains in the FLN TECs. The Danfoss PI loop is structured differently than the Siemens loop, so there is not a one-to-one correspondence between the gains. The following formulas allow translation between Danfoss and Siemens gains.

Converting from Danfoss PI gains to Siemens P and I gains:

$$P \text{ GAIN}_{\text{SIEMENS}} = PI \text{ GAIN}_{\text{DANFOSS}} * 0.0015$$

$$I \text{ GAIN}_{\text{SIEMENS}} = \frac{PI \text{ GAIN}_{\text{DANFOSS}}}{PI \text{ TIME}_{\text{DANFOSS}}} * 0.0015$$

Converting from Siemens P and I gains to Danfoss PI gains:

$$PI \text{ GAIN}_{\text{DANFOSS}} = P \text{ GAIN}_{\text{SIEMENS}} * 667$$

$$PI \text{ TIME}_{\text{DANFOSS}} = \frac{P \text{ GAIN}_{\text{SIEMENS}}}{I \text{ GAIN}_{\text{SIEMENS}}}$$

### Sleep Mode (54-59)

Sleep mode automatically stops the drive when demand is low over a period of time. When the system demand increases, the drive restarts the motor to reach the desired output. Sleep mode has great energy savings potential and saves wear and tear on equipment. Unlike a setback timer, the drive is always available to run when a preset "wake-up" demand is reached. See parameters 403 through 406 in the *VLT 6000 Operating Instructions* for more detail.

### Drive Control Display (80-86)

The operational status of the drive is readily available on the FLN serial interface bus. The drive displays various states including ready to start, waiting for run enable, run, fault reset and stop.

### Terminals 53, 54, 60 (87-89)

Two analog voltage input terminals 53 and 54 (0 to 10 VDC) and one analog current terminal 60 (0 to 20 mA) are provided for reference or feedback signals. The applied electrical signal can be read by data points 87 to 89 in volts and mA. This can be very useful during commissioning to calibrate transmitters. This can also be used to convert any other analog transmitter in the installation into a digital bus signal, even if the signal is not used by the drive. In this case, the input terminal should be programmed to *No Function* so it does not influence the drive's operation.

### Faults, Warnings and Alarms (90-94)

The drive displays a warning or tripped by a fault condition. It also can retrieve the last warning or fault trip for display. The drive can be reset through the FLN serial bus to resume normal drive operation.

### Error Status (99)

Data point 99 is implemented in the point map but is not used in this application.

### ■ VLT 6000 Network Strategies

The VLT 6000 drive has its own internal PID closed loop controller. This can be turned on or off, depending on the requirements of the control strategy. A brief summary of possibilities follows. This is meant to illustrate possibilities rather than be all-inclusive. An actual application may combine features from a more than one of these strategies.

#### Strategy One

**FLN Function** – Monitor drive operation

**VLT 6000 Control** – From a conventional, hardwired system

**VLT 6000 Mode** – Open Loop

The VLT 6000 follows hard-wired run/stop signals. An external, hard-wired PID controller provides the drive with a speed reference signal. The FLN monitors the operation of the drive without control function.

**Network Inputs to the VLT 6000:** Because the FLN is simply monitoring the operation of the drive, it provides no inputs.

**Network Outputs from the VLT 6000:** The following points are monitored by the FLN to indicate system status. This list could be expanded or shortened, depending on the requirements of the system.

03 FREQ OUTPUT  
08 POWER  
10 KWH  
23 STOP.RUN  
92 OK.FAULT

#### Strategy Two

**FLN Function** – Control all aspects of drive operation

**VLT 6000 Control** – From FLN

**VLT 6000 Mode** – Open Loop

The VLT 6000 follows run/stop and speed reference signals from the FLN. The FLN receives the feedback signal from the controlled system, compares this to a setpoint value, and uses its own PID control loop to determine the required drive speed.

### Network Inputs to the VLT 6000:

The following drive points might be controlled by the FLN.

#### Speed Command:

**53 BUS REF** – This is the speed reference command. This is set as a percentage of the drive's reference range, determined by VLT 6000 parameters 204, *Minimum Reference*, and 205, *Maximum Reference*. Setting point 53 to 0 gives the drive a reference command equal to the value stored in parameter 204. Setting point 53 to 16384 gives the drive a reference command equal to the value stored in parameter 205. Intermediate values for point 53 change the reference linearly between these two values.



#### NOTE:

In general, any other reference signal is added to the bus reference. Disable all other drivereference inputs when using a bus reference to control drive speed.

**Example 1:** In a pumping application, the minimum frequency (point 38 or parameter 201) is set to 18 Hz, and the maximum frequency (point 39 or parameter 202) is set to 60 Hz. You want to command the drive's speed with a 0 – 100% signal, where 0% commands 18 Hz and 100% commands 60 Hz. To unbundle the bus reference (point 53) for commanding in percent:

1. Set minimum reference (point 50 or parameter 204) to 18 Hz, the minimum frequency.
2. Set maximum reference (point 51 or parameter 205) to 60 Hz, the maximum frequency.
3. Intercept = 0 (since the minimum reference value is 0).
4. Slope can be calculated as follows:

$$\begin{aligned} \text{slope} &= \frac{(\text{DesiredRange}) \times (\text{Slope of ExistingPoint})}{\text{Range of ExistingPoint}} \\ &= \frac{100 \times 1}{16384} \\ &= 0.0061 \end{aligned}$$



**NOTE:**

Although range listed for point 53 is 32767, that represents a 200% speed command. Since a 100% speed command is desired here, half of value 32767 is used for range of existing point.

**Example 2:** In a pumping application, the minimum frequency (point 38 or parameter 201) is set to 18 Hz, and the maximum frequency (point 39 or parameter 202) is set to 60 Hz. You want to command the drive's speed with a 0 – 100% signal, where 0% commands 0 Hz and 100% commands 60 Hz. Because the minimum frequency is 30% of maximum speed, speed reference commands from 0 to 30% will cause the drive to run at minimum speed, 18 Hz.

To unbundle the bus reference (point 53) for commanding in percent:

1. Set minimum reference (point 50 or parameter 204) to 0 Hz.
2. Set maximum reference (point 51 or parameter 205) to 60 Hz, the maximum frequency.
3. Intercept = 0 (since the minimum reference value is 0)
4. Slope can be calculated as follows:

$$\begin{aligned} \text{slope} &= \frac{(\text{DesiredRange}) \times (\text{Slope of ExistingPoint})}{\text{Range of ExistingPoint}} \\ &= \frac{100 \times 1}{16384} \\ &= 0.0061 \end{aligned}$$

Although the action of the reference signal is different in examples 1 and 2, the unbundled reference is the same. This is due to programming minimum and maximum reference values in the drive.

**Start/Stop Command:** To give a start command from the FLN, the following points must be set. The VLT 6000 can also respond to discrete run/stop control signals that are hard wired to its control terminals. The point used to stop the drive through the FLN determines the capability of these discrete command signals.

**28 CMD COAST** – In most cases, it is necessary to set this point to NO to make the drive run. If this is set to COAST while the VLT 6000 is running, the drive will shut off immediately and the motor will coast to a stop. When set to COAST, the lower right corner of the drive display shows UN. READY (unit ready). The drive will not start in either HAND mode or through discrete control signals until point 28 is set to NO. VLT 6000 parameter 503, *Coasting*, can defeat this. See the *VLT 6000 Operating Instructions* for details. Because point 28 can keep the drive from operating in any mode, this is commonly used to provide a safety interlock function.

**24 CMD STP.STRT** – It is necessary to set this point to START to make the drive run. If this is set to STOP while the drive is running, the drive will decelerate to a stop. When this is set to STOP, the drive cannot be started using a hardwired discrete run command. It can, however, be started in HAND mode from the keypad.

**35 RUN ENABLE** – In most cases, it is necessary to set this point ON to make the drive run. If this is set to OFF while the drive is running, the drive will decelerate to a stop. When set to OFF, the lower right corner of the display shows STAND BY. When OFF, the drive can be started in HAND mode from the keypad. It can also be started using a hardwired discrete run command, as when parameter 505, *Start*, is set to digital input.

### Network Outputs from the VLT 6000:

The points listed in Strategy One are commonly used.

#### Strategy Three

##### FLN Function – Monitor drive operation

**VLT 6000 Control** – From a hard-wired system, including system feedback

##### VLT 6000 Mode – Closed Loop

The VLT 6000 follows hard-wired run/stop signals. The drive uses its internal PID controller to control motor speed. The feedback signal is hard wired to the VLT 6000 analog input and the setpoint is programmed into the drive. The FLN is used to monitor the status of the drive and the value of the VLT 6000 PID controller setpoint and feedback.

**Network Inputs to the VLT 6000:** Because the FLN is simply monitoring the operation of the drive, it provides no inputs.

**Network Outputs from the VLT 6000:** In addition to the points listed in Strategy One, it may be useful to monitor the following points related to the operation of the VLT 6000 PID controller.

#### Feedback:

- 60 INPUT REF** – This is the setpoint for the VLT 6000 PID controller in units defined in parameter 415, *Units Relating to Closed Loop*.
- 62 PI FEEDBACK** – This is the value of the feedback signal for the VLT 6000 PID controller in the units defined in parameter 415.

#### Strategy Four

**FLN Function** – Provide the drive with setpoint and feedback values using the VLT 6000 PID controller to determine motor speed

**VLT 6000 Control** – From the FLN

**VLT 6000 Mode** – Closed Loop

The VLT 6000 follows run/stop signals from the FLN. The FLN receives the feedback signal from the controlled system. It sends this and the desired

setpoint to the VLT 6000 PID controller. The drive compares the feedback signal with the setpoint and adjusts the speed of the drive accordingly.

**Network Inputs to the VLT 6000:** In addition to start/stop control, which was discussed in Strategy Two, the FLN provides the drive with feedback and setpoint information using the following points.

#### Feedback:

- 71 FB MIN** - The VLT 6000 can display the PID controller's setpoint and feedback signal in units chosen in drive parameter 415, *Units Relating to Closed Loop*. The value that the minimum feedback signal represents can be set using either point 71 or drive parameter 413, *Minimum Feedback*.
- 72 FB MAX** - The VLT 6000 can display the PID controller's setpoint and feedback signal in units chosen in drive parameter 415. The value that the maximum feedback signal represents can be set using either point 72 or drive parameter 414, *Maximum Feedback*.
- 73 BUS FB 1** - A value of 0 represents the minimum feedback signal, as defined by point 71 or parameter 413. A value of 16383 represents the maximum feedback signal, as defined by point 72 or parameter 414. This should be the feedback used if only one feedback signal is supplied to the drive.



#### NOTE:

If drive terminal 53 is programmed in parameter 308, *Analog Inputs*, for feedback, any signal applied to terminal 53 is added to value provided at point 73. Therefore, it is generally advisable not to program parameter 308 for feedback.

- 74 BUS FB 2** - This is used when two feedback signals are supplied to the drive PID controller. VLT 6000 parameter 417, *Feedback Function*, determines the function that the drive applies to these signals. Functions include minimum, maximum, sum, difference, and average. A value of 0 represents the minimum

feedback signal, as defined by point 71 or parameter 413. A value of 16383 represents the maximum feedback signal, as defined by point 72 or parameter 414. See the *VLT 6000 Operating In Istructions* for details.



**NOTE:**

If drive terminal 54 is programmed in parameter 311, *Analog Inputs*, for feedback, any signal applied to terminal 54 is added to value provided at point 73. Therefore, it is generally advisable not to program parameter 311 for feedback.

**Example:** In a cooling tower application, the feedback signal comes from a temperature sensor with a range of 40°F to 140°F. To unbundle bus feedback 2 (point 74) for the temperature sensor:

1. Set minimum feedback (point 71 or parameter 413) to 40.
2. Set maximum feedback (point 72 or parameter 414) 140.
3. Intercept = 40 (since the minimum feedback value is 40)
4. Slope can be calculated as follows:

$$\begin{aligned} \text{slope} &= \frac{(\text{Desired Range}) \times (\text{Slope of Existing Point})}{\text{Range of Existing Point}} \\ &= \frac{(140 - 40) \times 0.1}{16383} \\ &= 0.00061 \end{aligned}$$

Setpoint:

- 50 REF MIN** - The VLT 6000 can display the PID controller's setpoint and feedback signal in units. The units displayed are chosen in drive parameter 415. The value that the minimum reference signal represents can be set using either point 50 or drive parameter 204.
- 51 REF MIN** - The VLT 6000 can display the PID controller's setpoint and feedback signal in units. The units displayed are chosen in drive

parameter 415. The value that the maximum reference signal represents can be set using either point 51 or drive parameter 205.

- 69 SETPOINT 1** - This is the PID controller's setpoint, expressed in the units that were chosen in parameter 415. It can be set to any value between REF MIN (point 50 or parameter 204) and REF MAX (point 51 or parameter 205). If an attempt is made to set point 69 to a value outside of this range, the setpoint will not be changed. SETPOINT 1 can also be programmed using parameter 418, *Setpoint 1*.

- 70 SETPOINT 2** - This PID controller setpoint is used for applications where two feedback signals will be compared to independent setpoints. Refer to the *VLT 6000 Operating Instructions* for more details. SETPOINT 2 is expressed in the units selected in parameter 415. It can be set to any value between REF MIN (point 50 or parameter 204) and REF MAX (point 51 or parameter 205). If an attempt is made to assign point 70 to a value outside of this range, the setpoint will not change. SETPOINT 2 can also be programmed using parameter 419, *Setpoint 2*.

**PID Controller Adjustments:**

The following points adjust the operation of the VLT 6000 PID control loop. They are generally set during start-up and only adjusted if changes in the system require it. these values can also be set using parameters. See the *VLT 6000 Operating Instructions* for more details.

- 61 PI START FREQ** (parameter 422) - This sets the frequency to which the drive will accelerate after a start command. After it reaches this frequency, the drive will activate its PID controller. Point 61 can have a value between the drive's minimum frequency (as set in parameter 201) and its maximum frequency (as set in parameter 202). If an attempt is made to set point 61 to a value outside of this range, the drive value will not change.

- 63 PI GAIN** (parameter 423) - This sets the value of proportional gain for the VLT 6000 PID controller. It can have a value between 0 and 10.
- 64 PI I TIME** (parameter 424) - This sets the integral time for the VLT 6000 PID controller. It can have a value between 0.01 seconds and 9999 (OFF). In order for the controller to function properly, this should not be rned off.
- 65 PI GAIN LIMIT** (parameter 426) - This sets the maximum derivative gain for the VLT 6000 PID controller. It can have a value between 5 and 50.
- 66 LOWPASS FLTR** (parameter 427) - This sets the time constant for the noise filter in the VLT 6000 PID controller feedback loop. It can have values between 0.01 and 10 seconds.
- 68 FB FUNCTION** (parameter 417) - This sets how the VLT 6000 PID controller responds to the drive's two feedback signals. Its value is an integer between 0 and 6. Refer to the *VLT 6000 Operating Instructions* for the list of choices and an explanation of each.

**Network Outputs from the VLT 6000:** The points listed in Strategy One are commonly used.

### ■ VLT 6000 Special Functions

In addition to the control strategies described above, the VLT 6000 provides additional control flexibility to allow it to integrate into special control system requirements. The following are just a few examples.

#### **Safety Interlock:**

The VLT 6000 can accept a safety interlock stop command that is hard-wired to the drive control terminals and another from the FLN. When VLT 6000 parameter 304, *Digital Inputs*, is set to SAFETY INTERLOCK, an open hard-wired safety interlock will cause the drive to display ALARM 60 EXTERNAL FAULT. Setting point 28 to COAST will display UN. READY in the lower right corner of the drive's display. The individual displays for each allow the operator to determine which device caused

the trip. VLT 6000 parameter 503, *Coasting Stop*, determines the interaction of these two safety interlocks. See the *VLT 6000 Operating Instructions* for details.

#### **Analog Input Monitoring:**

Points 87, 88 and 89 can be used to monitor the value of the analog control signals applied to terminals 53, 54 and 60. These points are active even when NO FUNCTION is programmed for the analog input of the drive. As a result, it is possible to use the VLT 6000 analog inputs as analog input for the FLN.

#### **Drive Relay Control:**

While relay 1 and 2 in the VLT 6000 usually provide drive status indications, these indications are generally not needed when the drive is connected to an FLN. In some applications, it can be useful to have the FLN control these relays. For example, by controlling one of the relays, the FLN could select the active pump in a pump sequencing system. For the FLN to control a drive relay, the appropriate VLT 6000 parameter (323 or 326) must be set to CONTROL WORD 11/12. Setting point 40 or 41 to ON will then activate the corresponding relay.

### ■ Network Connection

Connect the VLT 6000 to the FLN in accordance with the following procedure (see Figure 2).

1. Connect signal wires to terminal 68 (P+) and terminal 69 (N-) on main control board of drive. (See tightening torque and wire size in Table 3.)
2. If shielded cabling is used, connect one end of shield to terminal 61. This terminal is connected to ground via an internal RC link.



#### **NOTE:**

It is recommended to use shielded, twisted-pair cables to reduce noise between conductors.

**Table 3** Tightening Torque and Wire Gage

|              |   |
|--------------|---|
| Torque Specs | 4.5 in lb/0.5 Nm  |
| Control wire | 18 - 24 AWG, shielded, twisted pair/1.5 mm, shielded twisted pair |

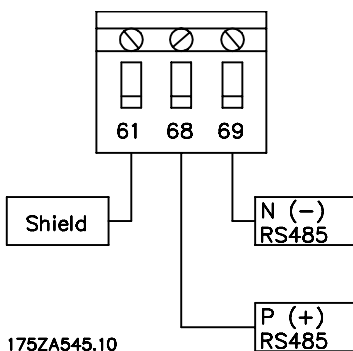

**Figure 2** Network Terminal Connection

### Hardware Setup

A terminator dip switch on the main control board of the VLT 6000 is used to configure the drives on the FLN bus. It is used for serial communication and to connect and disconnect the drive's digital inputs

from the drive's internal DC power supply. The switch positions shown in Figure 3 demonstrate the factory setting. Table 4 lists the switch functions and settings required for FLN operation.



**Figure 3** VLT 6000 Terminator Switch Factory Setting

**Table 4.** Terminator Switch Functions and FLN Settings

| Switch         | Setting   |
|----------------|---|
| Switch 1       | No function   |
| Switches 2 & 3 | Used for terminating an RS-485 interface. On <b>first</b> and <b>last</b> devices in a multiple device network, or on the <b>only</b> device in a single device network, switches 2 and 3 must be <b>ON</b> .<br><br>On <b>all other devices</b> in a multiple device network, 2 and 3 must be <b>OFF</b> .   |
| Switch 4       | Separates the common of the internal 24 VDC power supply from the common of the digital inputs.<br><br>Normally this switch is ON and the power supply is present at terminals 12 and 13 for digital inputs. When OFF, the negative of an external power supply is connected to terminal 20 and the positive output is used to turn on the desired digital inputs (terminals 16, 17, 18, 19, 27, 29, 32, and 33). |



### NOTE:

Terminator switch positions must be set correctly in accordance with Table 4 for proper FLN serial communication.



### Electrical Control Terminals

In most cases, the VLT 6000 will have electrical control connections (see Figure 4) already connected at equipment installation. The functional description of the drive's electrical control terminals in Table 5 are provided primarily for system modification and expansion. Two examples of typical

serial interface control connections are demonstrated in Figures 5 and 6. Many of these terminals have multiple functions that are determined by drive parameter settings. See the *VLT 6000 Operating Instructions* for detailed information.

**Table 5** Electrical Control Terminals Functional Description

| Number     | Function  |
|------------|---|
| 01, 02, 03 | Form C relay output. Maximum 240 VAC, 2 A. Minimum 24 VDC, 10 mA or 24 VAC, 100 mA. (Terminal group 01, 02, and 03 is placed in various locations on the power side of the drive, depending upon the model type.)   |
| 04, 05     | 30 VAC, 42.5 VDC, 1 Amp relay outputs can be used for indicating status and warnings.   |
| 12, 13     | Voltage supply to digital inputs and external transducers. For the 24 VDC to be used for digital inputs, switch 4 on the control card must be closed (position on). The maximum output current is 200 mA.   |
| 16 - 33    | Digital inputs. R = 2 kohm<br><5 V = logical 0<br>>10 V = logical 1   |
| 16 - 33    | 30 VAC, 42.5 VDC, 1 A relay output can be used for indicating status and warnings.  |
| 20         | Voltage supply to digital inputs and external transducers. For the 24 VDC to be used for digital inputs, switch 4 on the control card must be closed (position on). The maximum output current is 200 mA.   |
| 39         | Digital inputs. R = 2 kohm. <5 V = logical 0 , >10 V = logical 1  |
| 42, 45     | Analog and digital outputs for indicating frequency, reference, current and torque. The analog signal is 0 to 20 mA, or 4 to 20 mA at a maximum of 500 ?. The digital signal is 24 VDC at a minimum of 600 ?.   |
| 50         | 10 VDC, 17 mA maximum analog supply voltage to potentiometer and thermistor.  |
| 53, 54     | 0 to 10 VDC voltage input, R = 10 ?.  |
| 55         | Common for analog inputs. This common is isolated from the common of all other power supplies. If, for example, the drive s 24 VDC power supply is used to power an external transducer which provides an analog input signal, terminal 55 must be wired to terminal 39.  |
| 60         | 0 to 20 mA or 4 to 20 mA, analog current input, R = 188 ? .   |
| 61         | Shield for serial communication.  |
| 68, 69     | RS-485 interface and serial communication. When the drive is connected to an R -485 serial communication bus, DIP switches 2 and 3 must be closed on the first and the last device in the serial connection. On the remaining drives, switches 2 and 3 must be open. The factory setting is closed (position on). |

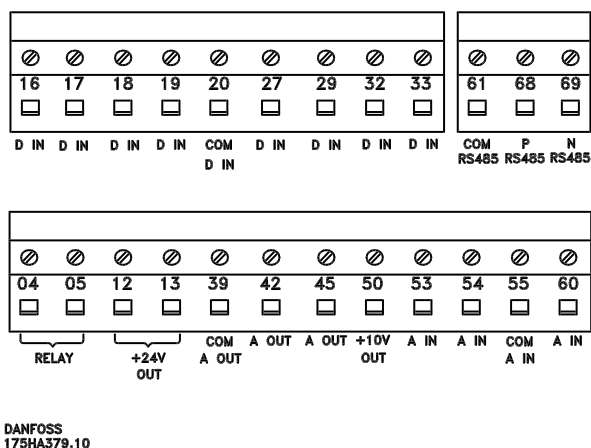
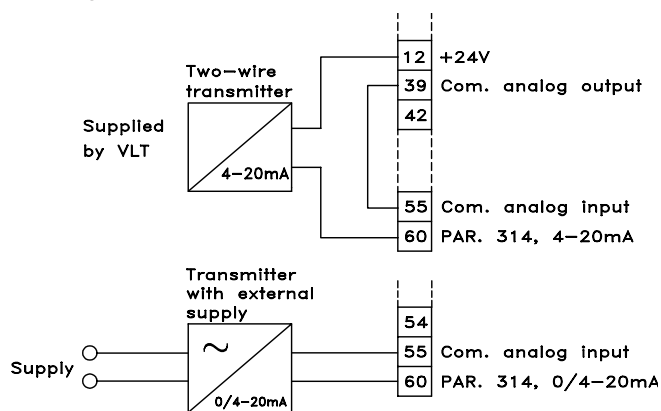

**Figure 4** Electrical Control Terminals

### Typical Control Connection Examples

#### Transmitter Connection:

The drive's internal 24 VDC power supply is used to power an external 4 to 20 mA transducer (see Figure 5).



**Figure 5** Transmitter Connection

Set Parameter 314, *Terminal 60, Analog Input Current*, to correspond to the purpose of the 4 to 20 mA signal.

Set Parameter 315, *Terminal 60, Min. Scaling*, to 4 mA.

Set Parameter 316, *Terminal 60, Max. Scaling*, to 20 mA.

Because the commons of the +24 VDC power supply and the input reference follower have separate circuit commons, it is necessary to connect a jumper between terminals 39 and 55.

#### Two Feedback Signals:

The drive processes two independent feedback signals during closed loop operation (see Figure 6). It can respond to the sum, difference, average, minimum or maximum of these signals.

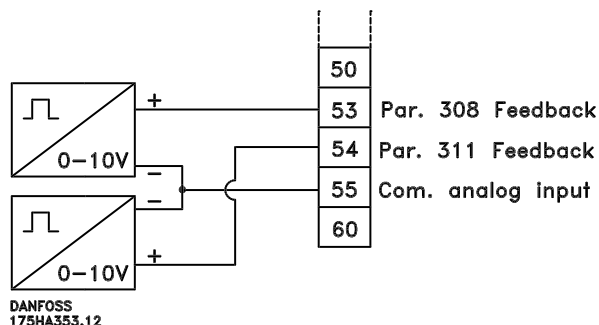

**Figure 6** Two Feedback Signals Connection

Set Parameter 308, *Terminal 53, Analog Input Voltage*, to FEEDBACK.

Set Parameter 311, *Terminal 54, Analog Input Voltage*, to FEEDBACK

Set Parameter 417, *Feedback Function*, for the desired operation.

### ■ Parameter Settings

The VLT 6000 has a unique FLN address which is transmitted over the RS-485 serial bus. The network will recognize the drive, which may then be programmed for setup options. The parameters listed in Table 6 need to be set for each drive on the FLN network. FLN communication related parameters can only be set through the LCP keypad.



#### NOTE:

As a minimum, it is required to set parameter 500, *Protocol*, to FLN; parameter 501, *Address*, to the proper address; and parameter 502, *Baud Rate*, to the proper baud rate. (See *Programming the VLT 6000* in this manual.)

Parameters 503 through 508 are options that select control of the drive through the digital and/or the FLN serial port. Parameter 565, *FLN Time Interval*, and 566, *FLN Time Interval Function*, can be commanded by the data points 36 and 37 (see Table 9).

**Table 6** VLT 6000 Parameter Settings

| Parameter | Description                | Default  | Desired setting |
|-----------|----------------------------|----------|-----------------|
| *500      | Protocol                   | FC       | FLN             |
| *501      | Address                    | 1        | 1 through 98    |
| *502      | Baud Rate                  | 9600     | 4800 or 9600    |
| **503     | Coasting                   | Logic or |                 |
| **504     | DC-brake                   | Logic or |                 |
| **505     | Start                      | Logic or |                 |
| **506     | Reversing                  | Digital  |                 |
| **507     | Selection of setup         | Logic or |                 |
| **508     | Selection of preset ref.   | Logic or |                 |
| 565       | FLN Time Interval          | 60 sec   | 1 - 65534 sec   |
| 566       | FLN Time Interval Function | Off      |                 |

\* Minimum parameters which must be set to operate the VLT 6000 via FLN serial interface.

\*\* When Digital input or Logic or is selected, digital inputs may interfere with serial bus commands. The setting Serial communication allows serial bus commands only to be carried out. See the VLT 6000 Operating Instructions for detailed descriptions.



#### NOTE:

Drive can store preset references programmed in parameters 211 through 214, *Preset Reference (1-4)*. To avoid these values modifying serial bus references, set parameter 210, *Reference Type*, to *External/preset*. See *VLT 6000 Operating Instructions* for detailed description.

**Startup of FLN Control**

This procedure assumes that the VLT 6000 adjustable frequency drive has been installed properly and is operational in Hand control mode. It also assumes the Siemens FLN data bus is connected to an operational controller. Start the VLT 6000 in accordance with the following procedure.

1. Ensure that the assumptions in this procedure are correct.
2. Check that the network connections are securely fastened in accordance with Figure 2.



Verify compliance with all safety requirements listed in this manual.

3. Apply power to the VLT 6000.
4. Ensure that the minimum settings listed in Table 6 are selected.
5. Ensure that the switch positions in Figure 3 are set correctly.
6. Optional settings may be changed to meet or enhance the drive's operation, depending on the application requirements.
7. For FLN control of the drive, press the AUTO START key on the VLT 6000 LCP keypad. Drive operation can then be controlled through the host network device in accordance with its operation instructions.

**NOTE:**

Default setting for point number 35, *Run Enable*, is OFF. Drive will not operate until *Run Enable* ON signal is given through serial communication network.

**Faults, Warnings and Alarms**

**DANGER:**

A stopped motor may start unexpectedly if faults occur in electronics of drive, or if an active fault clears, such as a fault in supply AC line, or fault in motor connection, or overload.

The VLT 6000 adjustable frequency drive outputs faults, warnings and alarms on the FLN serial bus in a numerical code. The code numbers are described in Table 7. The Reset key is used for manually resetting the drive after an alarm (fault trip). In this case, the top line of the display will show TRIP (RESET). If the top line of the display shows TRIP (AUTO START), the drive will automatically restart. If the top line of the display shows TRIPLOCK (DISC. MAINS), input power to the drive must be cycled off and on again before the trip can be reset.

Refer to the *VLT 6000 Operating Instructions* for detailed descriptions.

**Table 7** Faults, Warnings and Alarms Description

| Fault number | Description                    | Warning | Alarm              |                         |
|--------------|--------------------------------|---------|--------------------|-------------------------|
|              |                                |         | Trip <sup>1)</sup> | Trip Lock <sup>2)</sup> |
| 1            | 10 volts low                   | X       |                    |                         |
| 2            | Live zero                      | X       | X                  |                         |
| 4            | AC power failure               | X       | X                  | X                       |
| 5            | DC link voltage hig            | X       |                    |                         |
| 6            | DC link voltage low            | X       |                    |                         |
| 7            | Over voltage                   | X       | X                  |                         |
| 8            | Under voltage                  | X       | X                  |                         |
| 9            | Inverter time                  | X       | X                  |                         |
| 10           | Motor time                     | X       | X                  |                         |
| 11           | Motor thermistor               | X       | X                  |                         |
| 12           | Current limit                  | X       | X                  |                         |
| 13           | Over current                   |         | X                  | X                       |
| 14           | Ground fault                   |         | X                  | X                       |
| 15           | Switch mode fault              |         | X                  | X                       |
| 16           | Current short circuit          |         | X                  | X                       |
| 17           | Serial comm. timeout           | X       | X                  |                         |
| 18           | HPFB timeout                   | X       | X                  |                         |
| 19           | EEPROM on power card           | X       |                    |                         |
| 20           | EEPROM o control card          | X       |                    |                         |
| 22           | AMA fault                      |         | X                  |                         |
| 29           | Heat sink temperature too high |         | X                  | X                       |
| 30           | Motor phase U missing          |         | X                  |                         |
| 31           | Motor phase V missing          |         | X                  |                         |
| 32           | Motor phase W missing          |         | X                  |                         |
| 34           | HPFB comm. fault               | X       | X                  |                         |
| 37           | Inverter fault                 |         | X                  | X                       |
| 39           | AMA check par. 104, 106        | X       |                    |                         |
| 40           | AMA check par. 103, 105        | X       |                    |                         |
| 41           | AMA motor too big              | X       |                    |                         |
| 42           | AMA motor too small            | X       |                    |                         |
| 60           | External fault                 |         | X                  |                         |
| 61           | Output frequency low           | X       |                    |                         |
| 62           | Output frequency high          | X       |                    |                         |
| 63           | Output current lo              | X       | X                  |                         |
| 64           | Output current high            | X       |                    |                         |
| 65           | Feedback low                   | X       |                    |                         |
| 66           | Feedback hig                   | X       |                    |                         |
| 67           | Reference low                  | X       |                    |                         |
| 68           | Reference high                 | X       |                    |                         |
| 69           | Thermal Auto derating          | X       |                    |                         |
| 99           | Unknown alarm                  |         | X                  | X                       |

1) Trip: Requires a reset, either manual or automatic, depending on the the setting of parameter 400, *Reset Function*.

2) Trip lock: Requires AC power cycled on and off and a reset.

Alarms that also have a corresponding warning cannot be reset until warning has been removed, i.e., fault situation is gone.

Points 90-91 refer to warnings. Points 92-94 refer to alarms.



## VLT® Adjustable Frequency Drive

### Point Mapping Table

The VLT 6000 parameters, along with the internal variables and readouts for controlling the drive via the FLN serial bus, are organized as a Point Map. Not all parameters and readouts are supported by the FLN protocol. FLN points 01, 02, 20, 29 and 99

are predefined. Available points and a description of their characteristics are listed in Table 8. Parameters which can be written to (“W” in the Read/Write column) are programmable through the FLN device, others (“R”) are read-only, or read and write (“R/W”).

**Table 8** Point Mapping

| Point Number                       | Descriptor            | Factory Default (SI Units) | SI Units | Slope (SI Units) | Intercept (SI Units) | Range | On Text | Off Text | Read/Write | Param. number | Network Port Type<br>Note 1 |
|------------------------------------|-----------------------|----------------------------|----------|------------------|----------------------|-------|---------|----------|------------|---------------|-----------------------------|
| 01                                 | CTLR ADDRESS          | 1                          | --       | 1                | 0                    | 255   | --      | --       | R          | 501           | Pre-defined                 |
| 02                                 | APPLICATION           | 2709                       | --       | 1                | 0                    | 255   | --      | --       | R          | --            | Pre-defined                 |
| <b>Readout Points</b>              |                       |                            |          |                  |                      |       |         |          |            |               |                             |
| {03}                               | FREQ OUTPUT           | 0                          | HZ       | 0.1              | 0                    | 16383 | --      | --       | R          | 512           | LAI                         |
| {06}                               | CURRENT               | 0                          | A        | 0.1              | 0                    | 16383 | --      | --       | R          | 514           | LAI                         |
| {08}                               | POWER                 | 0                          | KW       | 1                | 0                    | 511   | --      | --       | R          | 515           | LAI                         |
| {10}                               | KWH                   | 0                          | KWH      | 3.1              | 0                    | 32767 | --      | --       | R          | 602           | LAI                         |
| {12}                               | RUN TIME              | 0                          | HRS      | 4.0              | 0                    | 32767 | --      | --       | R          | 601           | LAI                         |
| {13}                               | DC BUS VOLT           | 0                          | VOLTS    | 1                | 0                    | 1023  | --      | --       | R          | 518           | LAI                         |
| {14}                               | OUTPUT VOLT           | 0                          | VOLTS    | 1                | 0                    | 1023  | --      | --       | R          | 517           | LAI                         |
| {15}                               | MOTOR THERM           | 0                          | PCT      | 1                | 0                    | 255   | --      | --       | R          | 519           | LAI                         |
| {16}                               | DRIVE THERM           | 0                          | PCT      | 1                | 0                    | 255   | --      | --       | R          | 520           | LAI                         |
| {17}                               | CURR. SETU            | 0                          | --       | 1                | 0                    | 255   | --      | --       | R          | --            | LAI                         |
| {18}                               | TIMERS STAT           | 0                          | --       | --               | --                   | --    | LIMIT   | OK       | R          | 527-15        | LDI                         |
| {19}                               | CURRENT STAT          | 0                          | --       | --               | --                   | --    | LIMIT   | OK       | R          | 527-14        | LDI                         |
| 20                                 | OVRD TIME             | 1                          | HRS      | 1                | 0                    | 255   | --      | --       | W          | --            | Pre-defined                 |
| <b>Status and Command Points</b>   |                       |                            |          |                  |                      |       |         |          |            |               |                             |
| {21}                               | FWD.REV               | FWD                        | --       | --               | --                   | --    | REV     | FWD      | R          | 532-8         | LDI                         |
| {22}                               | CMD FWD.REV           | FWD                        | --       | --               | --                   | --    | REV     | FWD      | W          | Cmd-15        | LDO                         |
| {23}                               | STOP.RUN              | STOP                       | --       | --               | --                   | --    | RUN     | STOP     | R          | 527-11        | LDI                         |
| {24}                               | CMD STP.STRT          | STOP                       | --       | --               | --                   | --    | START   | STOP     | W          | Cmd-4         | LDO                         |
| {25}                               | FREEZE OUT            | NO                         | --       | --               | --                   | --    | FREEZE  | NO       | R          | 532-16        | LDI                         |
| {26}                               | CMD FREEZE            | FREEZE                     | --       | --               | --                   | --    | NO      | FREEZE   | W          | Cmd-5         | LDO                         |
| {27}                               | COAST                 | COAST                      | --       | --               | --                   | --    | NO      | COAST    | R          | 530-3         | LDI                         |
| {28}                               | CMD COAST             | COAST                      | --       | --               | --                   | --    | NO      | COAST    | W          | Cmd-3         | LDO                         |
| <b>Common Configuration Points</b> |                       |                            |          |                  |                      |       |         |          |            |               |                             |
| 29                                 | DAY.NIGHT<br>Note 2   | DAY                        | --       | --               | --                   | 255   | NIGHT   | DAY      | W          | --            | Pre-defined                 |
| {30}                               | CURRENT LIM<br>Note 3 | Note 4                     | A        | 0.1              | 0.1                  | 16383 | --      | --       | W          | 215           | LAO                         |
| {31}                               | ACCEL TIME 1          | Note 4                     | SEC      | 1                | 1                    | 4095  | --      | --       | R/W        | 206           | LAO                         |
| {32}                               | DECEL TIME 1          | Note 4                     | SEC      | 1                | 1                    | 4095  | --      | --       | R/W        | 207           | LAO                         |



## VLT® Adjustable Frequency Drive

VLT® Adjustable Frequency Drive

| Point Number                   | Descriptor             | Factory Default (SI Units) | SI Units | Slope (SI Units) | Intercept (SI Units) | Range           | On Text | Off Text | Read/Write | Param. number | Network Port Type<br>Note 1 |
|--------------------------------|------------------------|----------------------------|----------|------------------|----------------------|-----------------|---------|----------|------------|---------------|-----------------------------|
| {33}                           | LOCK PANEL<br>Note 5   | OPEN                       | --       | --               | --                   | --              | LOCK    | OPEN     | R/W        | 12-15         | LDO                         |
| {34}                           | SEL HND.AUTO           | HAND                       | --       | --               | --                   | --              | AUTO    | HAND     | R          | 532-13        | LDI                         |
| {35}                           | RUN ENABLE             | OFF                        | --       | --               | --                   | --              | ON      | OFF      | W          | Cmd-6         | LDO                         |
| {36}                           | BUS TIME               | 60                         | SEC      | 2                | 2                    | 32767           | --      | --       | R/W        | 565           | LAO                         |
| {37}                           | BUSTIME FUNC           | 0<br>Note 6                | --       | 1                | 0                    | 255             | --      | --       | R/W        | 566           | LAO                         |
| {38}                           | F OUT LOW<br>Note 3    | 0                          | HZ       | 0.1              | 0                    | 16383           | --      | --       | W          | 201           | LAO                         |
| {39}                           | F OUT HIGH<br>Note 3   | Note 4                     | HZ       | 0.1              | 0                    | 16383           | --      | --       | W          | 202           | LAO                         |
| <b>Physical Output Points</b>  |                        |                            |          |                  |                      |                 |         |          |            |               |                             |
| {40}                           | RELAY OUT 1            | OFF                        | --       | --               | --                   | --              | ON      | OFF      | W          | Cmd-11        | LDO                         |
| {41}                           | RELAY OUT 2            | OFF                        | --       | --               | --                   | --              | ON      | OFF      | W          | Cmd-12        | LDO                         |
| {42}                           | PI STRT FR.            | 0                          | HZ       | 0.1              | 0                    | 16383           | --      | --       | R          | 422           | LAI                         |
| {43}                           | RELAY 1 STA            | OFF                        | --       | --               | --                   | --              | ON      | OFF      | R          | 530-11        | LDI                         |
| {44}                           | RELAY 1 STA            | OFF                        | --       | --               | --                   | --              | ON      | OFF      | R          | 530-12        | LDI                         |
| {45}                           | CURR. LIM.S            | Note 4                     | A        | 0.1              | 0.1                  | 16383           | --      | --       | R          | 215           | LAI                         |
| {46}                           | F OUT LOW.S            | 0                          | HZ       | 0.1              | 0                    | 16383           | --      | --       | R          | 201           | LAI                         |
| {47}                           | F OUT HIGH.S           | Note 4                     | HZ       | 0.1              | 0                    | 16383           | --      | --       | R          | 202           | LAI                         |
| {48}                           | REF MIN.S              | 0                          | UNIT     | 0.1              | -1638.3              | 32767           | --      | --       | R          | 204           | LAI                         |
| {49}                           | REF MAX.S              | Note 4                     | UNIT     | 0.1              | -1638.3              | 32767           | --      | --       | R          | 205           | LAI                         |
| <b>Setpoint Related Points</b> |                        |                            |          |                  |                      |                 |         |          |            |               |                             |
| {50}                           | REF MIN<br>Note 3      | 0                          | UNIT     | 0.1              | -1638.3              | 32767           | --      | --       | W          | 204           | LAO                         |
| {51}                           | REF MAX<br>Note 3      | Note 4                     | UNIT     | 0.1              | -1638.3              | 32767           | --      | --       | W          | 205           | LAO                         |
| {52}                           | REF STAT               | OFFREF                     | --       | --               | --                   | --              | ON.REF  | OFFREF   | R          | 527-8         | LDI                         |
| {53}                           | BUS REF                | 0                          | --       | 1                | 0                    | 32767<br>Note 7 | --      | --       | R/W        | --            | LAO                         |
| {54}                           | SLEEP FREQ.S           | 0                          | HZ       | 0.1              | 0                    | 16383           | --      | --       | R          | 404           | LAI                         |
| {55}                           | WAKEUP FRQ.S           | Note 4                     | HZ       | 0.1              | 0                    | 16383           | --      | --       | R          | 405           | LAI                         |
| {56}                           | SLEEP TIME             | 301                        | SEC      | 1                | 0                    | 511             | --      | --       | R          | 403           | LAI                         |
| {57}                           | SLEEP FREQ<br>Note 3   | 0                          | HZ       | 0.1              | 0                    | 16383           | --      | --       | W          | 404           | LAO                         |
| {58}                           | WAKEUP FREQ<br>Note 3  | Note 4                     | HZ       | 0.1              | 0                    | 16383           | --      | --       | W          | 405           | LAO                         |
| {59}                           | SLEEP MODE             | OFF                        | --       | --               | --                   | --              | SLEEP   | OFF      | R          | 532-3         | LDI                         |
| <b>PI Loop Related Points</b>  |                        |                            |          |                  |                      |                 |         |          |            |               |                             |
| {60}                           | INPUT REF              | 0                          | UNIT     | 0.1              | -1638.3              | 32767           | --      | --       | R          | 510           | LAI                         |
| {61}                           | PI STRT FREQ<br>Note 3 | 0                          | HZ       | 0.1              | 0                    | 16383           | --      | --       | W          | 422           | LAO                         |
| {62}                           | PI FEEDBACK            | 0                          | UNIT     | 0.1              | -1638.3              | 32767           | --      | --       | R          | 511           | LAI                         |
| {63}                           | PI GAIN                | 0.3                        | --       | 0.01             | 0                    | 1023            | --      | --       | R/W        | 423           | LAO                         |
| {64}                           | PI I TIME              | 9999                       | SEC      | 0.3051543        | 0.01                 | 32767           | --      | --       | R/W        | 424           | LAO                         |



## VLT® Adjustable Frequency Drive

VLT® Adjustable Frequency Drive

| Point Number                | Descriptor             | Factory Default (SI Units) | SI Units | Slope (SI Units) | Intercept (SI Units) | Range | On Text | Off Text | Read/Write | Param. number | Network Port Type<br>Note 1 |
|-----------------------------|------------------------|----------------------------|----------|------------------|----------------------|-------|---------|----------|------------|---------------|-----------------------------|
| {65}                        | PI GAIN LIM            | 5                          | --       | 0.1              | 0                    | 511   | --      | --       | R/W        | 426           | LAO                         |
| {66}                        | LOWPASS FLTR           | 0.01                       | SEC      | 0.01             | 0                    | 1023  | --      | --       | R/W        | 427           | LAO                         |
| {67}                        | SLEEP BOOST            | OFF                        | --       | --               | --                   | --    | BOOST   | OFF      | R          | 532-2         | LDI                         |
| {68}                        | FB FUNC                | 1<br>Note 6                | --       | 1                | 0                    | 255   | --      | --       | R/W        | 417           | LAO                         |
| {69}                        | SETPOINT 1<br>Note 3   | 0                          | UNIT     | 0.1              | -1638.3              | 32767 | --      | --       | W          | 418           | LAO                         |
| {70}                        | SETPOINT 2<br>Note 3   | 0                          | UNIT     | 0.1              | -1638.3              | 32767 | --      | --       | W          | 419           | LAO                         |
| {71}                        | FB MIN<br>Note 3       | 0                          | UNIT     | 0.1              | -1638.3              | 32767 | --      | --       | W          | 413           | LAO                         |
| {72}                        | FB MAX<br>Note 3       | 100.0                      | UNIT     | 0.1              | -1638.3              | 32767 | --      | --       | W          | 414           | LAO                         |
| {73}                        | BUS FB 1               | 0                          | --       | 1                | 0                    | 16383 | --      | --       | R/W        | 535           | LAO                         |
| {74}                        | BUS FB 2               | 0                          | --       | 1                | 0                    | 16383 | --      | --       | R/W        | 536           | LAO                         |
| <b>Miscellaneous Points</b> |                        |                            |          |                  |                      |       |         |          |            |               |                             |
| {75}                        | AUTO RAMP              | OFF                        | --       | --               | --                   | --    | ACTIVE  | OFF      | R          | 532-0         | LDI                         |
| {76}                        | VOLT STAT              | OK                         | --       | --               | --                   | --    | LIMIT   | OK       | R          | 527-13        | LDI                         |
| {77}                        | INVERT STA             | OK                         | --       | --               | --                   | --    | STALL   | OK       | R          | 527-12        | LDI                         |
| {78}                        | FREQ STAT              | OUTRNG                     | --       | --               | --                   | --    | IN.RNG  | OUTRNG   | R          | 527-10        | LDI                         |
| {79}                        | CTRL STAT              | LOCAL                      | --       | --               | --                   | --    | BUS     | LOCAL    | R          | 527-9         | LDI                         |
| {80}                        | DRV ENA STAT           | NOTENA                     | --       | --               | --                   | --    | ENABLE  | NOTENA   | R          | 527-2         | LDI                         |
| {81}                        | DRV RDY STAT           | NOTRDY                     | --       | --               | --                   | --    | READY   | NOTRDY   | R          | 527-1         | LDI                         |
| {82}                        | DRVCTRL STAT           | NOTRDY                     | --       | --               | --                   | --    | READY   | NOTRDY   | R          | 527-0         | LDI                         |
| {84}                        | RESET                  | NO                         | --       | --               | --                   | --    | RESET   | NO       | R          | 530-7         | LDI                         |
| {85}                        | START                  | OFF                        | --       | --               | --                   | --    | ON      | OFF      | R          | 530-6         | LDI                         |
| {86}                        | Q.STOP                 | Q.STOP                     | --       | --               | --                   | --    | NO      | Q.STOP   | R          | 530-4         | LDI                         |
| {87}                        | TERM 53                | 0                          | VOLTS    | 0.1              | 0                    | 255   | --      | --       | R          | 522           | LAI                         |
| {88}                        | TERM 54                | 0                          | VOLTS    | 0.1              | 0                    | 255   | --      | --       | R          | 523           | LAI                         |
| {89}                        | TERM 60                | 0                          | MILAMP   | 0.1              | 0                    | 255   | --      | --       | R          | 524           | LAI                         |
| <b>Error Related Points</b> |                        |                            |          |                  |                      |       |         |          |            |               |                             |
| {90}                        | OK.WARNING             | OK                         | --       | --               | --                   | --    | WARN    | OK       | R          | 527-7         | LDI                         |
| {91}                        | LAST WARNING           | 0<br>Note 8                | --       | 1                | 0                    | 255   | --      | --       | R          | --            | LAI                         |
| {92}                        | OK.FAULT               | OK                         | --       | --               | --                   | --    | FAULT   | OK       | R          | 527-3         | LDI                         |
| {93}                        | LAST FAULT             | 0<br>Note 8                | --       | 1                | 0                    | 255   | --      | --       | R          | 615           | LAI                         |
| {94}                        | RESET FAULT            | NO                         | --       | --               | --                   | --    | RESET   | NO       | W          | --            | LDO                         |
| {95}                        | SETPOINT 1.S           | 0                          | UNIT     | 0.1              | -1638.3              | 32767 | --      | --       | R          | 418           | LAI                         |
| {96}                        | SETPOINT 2.S           | 0                          | UNIT     | 0.1              | -1638.3              | 32767 | --      | --       | R          | 419           | LAI                         |
| {97}                        | FB MIN.S               | 0                          | UNIT     | 0.1              | -1638.3              | 32767 | --      | --       | R          | 413           | LAI                         |
| {98}                        | FB MAX.S               | 100.0                      | UNIT     | 0.1              | -1638.3              | 32767 | --      | --       | R          | 414           | LAI                         |
| 99                          | ERROR STATUS<br>Note 2 | 0                          | --       | 1                | 0                    | 255   | --      | --       | R          | --            | Pre-defined                 |



**Point Mapping Table Notes:**

Point numbers that appear in brackets { } may be unbundled at the field panel.

**Note 1:** LAI stands for “Logical Analog Input.” This is an analog value that the VLT 6000 provides to the FLN network. Its value is a feedback indicating the status of a physical input to the drive.  
LAO stands for “Logical Analog Output.” This is an analog output from the FLN network to the VLT 6000. It is used to control the operation of the drive.  
LDI stands for “Logical Digital Input.” This is a digital (ON/OFF) signal from the VLT 6000 to the FLN network. It indicates the operation of the drive.  
LDO stands for “Logical Digital Output.” This is a digital (ON/OFF) signal from the FLN network to the VLT 6000. It is used to control or indicate the operation of the drive.

**Note 2:** Points 29 and 99 are present but not used in this application.

**Note 3:** These points will accept any value within the range of the point even though the drive has different upper and/or lower limits for these points. This is because the upper and lower limits for these points can vary depending on settings of other points or the drive size. Consult the *VLT 6000 Operating Instructions* for values.

Twelve special read-only points can be used for checking if the value actually changed or the change was rejected. These 12 read-only points should also be used for monitoring database COVs which the others cannot. The read-only points are designated by a descriptor similar to the original point with a suffix “.S” added.

Below is a list of pairing where the points in parenthesis are the read-only points:  
30 (45), 38 (46), 39 (47), 50 (48), 51 (49), 57 (54), 58 (55), 61 (42), 69 (95), 70 (96), 71 (97), 72 (98).

**Note 4:** The default value depends on the drive. Consult the *VLT 6000 Operating Instructions* for values.

**Note 5:** When LOCK PANEL is set to LOCK, the “Hand Start”, “Off Stop”, “Auto Start” and “Reset” keys on the VLT 6000 keypad will be disabled. Four parameters in the drive will change simultaneously. Local programming of the drive will also be locked except for parameter 016, *Lock for Data Change*, which can disable the programming lock.

**Note 6:** Consult the *VLT 6000 Operating Instructions* for choice options.

**Note 7:** The number 32767 equals 200% of Bus Ref range value.

**Note 8:** Use Table 7, *Faults, Warnings and Alarms*, to determine the FAULT or WARNING corresponding to a number.



## VLT® Adjustable Frequency Drive

### Point Database Definitions

Table 9 Point Database Definitions

| Point Number | Descriptor    | Definition   |
|--------------|---------------|--|
| 01           | CTLR ADDRESS  | Predefined device address.   |
| 02           | APPLICATION   | Predefined FLN application for use with VLT 6000 drive.                              |
| 03           | FREQ OUTPUT   | Displays drive speed in hertz.   |
| 06           | CURRENT       | Displays drive output current in amps.   |
| 08           | POWER         | Displays drive power output in kilowatts.  |
| 10           | KWH           | Displays drive cumulative energy output in kilowatt-hours.                           |
| 12           | RUN TIME      | Displays number of hours drive has supplied power to motor.                          |
| 13           | DC BUS VOLT   | Displays drive voltage at DC bus in DC volts.  |
| 14           | OUTPUT VOLT   | Displays output voltage to motor in AC volts.  |
| 15           | MOTOR THERM   | Displays motor thermal load in percentage.   |
| 16           | DRIVE THERM   | Displays drive thermal load in percentage.   |
| 17           | CURR. SETUP   | Displays parameter setup number currently controlling drive.                         |
| 18           | TIMERS STAT   | Displays if temperature limit of motor, drive or motor thermistor has been exceeded. |
| 19           | CURRENT STAT  | Displays if drive is operating in current limit.                                     |
| 20           | OVRD TIME     | Not used.  |
| 21           | FWD.REV       | Displays direction of motor rotation, forward or reverse.                            |
| 22           | CMD FWD.REV   | Commands direction of motor rotation.  |
| 23           | STOP.RUN      | Displays drive RUN/STOP status.  |
| 24           | CMD STP.STRT  | Commands drive to start or stop.   |
| 25           | FREEZE OUT    | Displays if output frequency is in freeze mode at present value.                     |
| 26           | CMD FREEZE    | Commands drive to freeze present output frequency.                                   |
| 27           | COAST         | Displays if drive has been given a coast to stop command.                            |
| 28           | CMD COAST     | Commands drive to make motor coast to a stop.  |
| 29           | DAY.NIGHT     | Selects day or night mode. (Has no effect on drive operation.)                       |
| 30           | CURRENT LIM   | Sets maximum drive output current to motor in amps.                                  |
| 31           | ACCEL TIME 1  | Sets motor ramp up time in seconds.  |
| 32           | DECEL TIME 1  | Sets motor ramp down time in seconds.  |
| 33           | LOCK PANEL    | Used to lock out Hand Start, Off/Start, Auto Start and Reset keys on LCP.            |
| 34           | SEL HAND.AUTO | Displays operation in Hand or Auto control mode function.                            |
| 35           | RUN ENABLE    | Used to enable or disable drive operation in auto mode.                              |
| 36           | BUS TIME      | Sets time limit to determine loss of serial communication in seconds.                |
| 37           | BUSTIME FUNC  | Selects drive response to loss of serial communication.                              |
| 38           | F OUT LOW     | Sets minimum drive output frequency.   |
| 39           | F OUT HIGH    | Sets maximum drive output frequency.   |
| 40           | RELAY OUT 1   | Controls drive relay output 1. Note: Set relay output to corresponding function.     |
| 41           | RELAY OUT 2   | Controls drive relay output 2. Note: Set relay output to corresponding function.     |
| 42           | PI STRT FR.S  | Displays status of point 61.   |
| 43           | RELAY 1 STAT  | Displays status of FLN command to drive relay output 1.                              |
| 44           | RELAY 2 STAT  | Displays status of FLN command to drive relay output 2.                              |
| 45           | CURR. LIM.S   | Displays status of point 30.   |
| 46           | F OUT LOW.S   | Displays status of point 38.   |
| 47           | F OUT HIGH.S  | Displays status of point 39.   |
| 48           | REF MIN.S     | Displays status of point 50.   |
| 49           | REF MAX.S     | Displays status of point 51.   |
| 50           | REF MIN       | Sets lowest frequency reference value for drive.                                     |
| 51           | REF MAX       | Sets highest frequency reference value for drive.                                    |
| 52           | REF STAT      | Displays if drive is running at commanded reference.                                 |



## VLT® Adjustable Frequency Drive

| Point Number | Descriptor     | Definition  |
|--------------|----------------|---|
| 53           | BUS REF        | Sends drive an external reference signal in percent.                                |
| 54           | SLEEP FREQ.S   | Displays status of point 57.  |
| 55           | WAKEUP FREQ.S  | Displays status of point 58.  |
| 56           | SLEEP TIME     | Displays run time at low speed before sleep mode starts.                            |
| 57           | SLEEP FREQ     | Sets output frequency required to activate sleep mode timer.                        |
| 58           | WAKEUP FREQ    | Sets command frequency required to restart motor after sleep mode.                  |
| 59           | SLEEP MODE     | Displays when drive is stopped in sleep mode.                                       |
| 60           | INPUT REF      | Displays drive input reference in Hz or as selected in parameter 415.               |
| 61           | PI STRT FREQ   | Sets drive frequency after start at which PID control is activated.                 |
| 62           | PI FEEDBACK    | Displays resulting feedback value in units selected in parameter 415.               |
| 63           | PI GAIN        | Sets proportional gain of PID controller in percentage.                             |
| 64           | PI TIME        | Sets integral time of PID controller in seconds.                                    |
| 65           | PI GAIN LIM    | Sets maximum gain for differentiator of PID controller.                             |
| 66           | LOWPASS FILTER | Sets lowpass filter time constant for feedback circuit.                             |
| 67           | SLEEP BOOST    | Displays sleep boost set point in percentage.                                       |
| 68           | FB FUNC        | Selects calculation method when two feedback signals are used.                      |
| 69           | SETPOINT 1     | Sets setpoint for feedback 1 in units selected in parameter 415.                    |
| 70           | SETPOINT 2     | Sets setpoint for feedback 2 in units selected in parameter 415.                    |
| 71           | FB MIN         | Sets minimum feedback signal value in units selected in parameter 415.              |
| 72           | FB MAX         | Sets maximum feedback signal value in units selected in parameter 415.              |
| 73           | BUS FB 1       | Supplies feedback value for bus feedback 1 in percent.                              |
| 74           | BUS FB 2       | Supplies feedback value for bus feedback 2 in percent.                              |
| 75           | AUTO RAMP      | Displays when drive deceleration rate is extended due to auto ramping.              |
| 76           | VOLT STAT      | Displays if drive DC bus voltage exceeds high/low warning limits.                   |
| 77           | INVERT STAT    | Displays drive inverter status, ok or stall.  |
| 78           | FREQ STAT      | Displays if drive is running outside of frequency limits of parameters 223 and 224. |
| 79           | CTRL STAT      | Displays whether drive is in local control or FLN serial bus.                       |
| 80           | DRV ENA STAT   | Displays if drive is enabled to start when run command given.                       |
| 81           | DRV RDY STAT   | Displays if drive control is ready or if a trip has occurred.                       |
| 82           | DRVCTRL STAT   | Displays drive control status as ready or not ready.                                |
| 84           | RESET          | Displays if a fault reset command has been given via serial bus.                    |
| 85           | START          | Displays if a run command has been given via serial bus.                            |
| 86           | Q.STOP         | Displays if a stop command has been given via serial bus.                           |
| 87           | TERM 53        | Displays voltage value of signal on terminal 53 in volts.                           |
| 88           | TERM 54        | Displays voltage value of signal on terminal 54 in volts.                           |
| 89           | TERM 60        | Displays current value of signal on terminal 60 in mA.                              |
| 90           | OK.WARNING     | Displays if drive is in a warning condition.  |
| 91           | LAST WARNING   | Displays last drive warning.  |
| 92           | OK.FAULT       | Displays if drive has been tripped due to a fault.                                  |
| 93           | LAST FAULT     | Displays last drive fault trip.   |
| 94           | RESET FAULT    | Resets drive faults and resumes normal drive operation.                             |
| 95           | SETPOINT 1.S   | Displays status of point 69.  |
| 96           | SETPOINT 2.S   | Displays status of point 70.  |
| 97           | FB MIN.S       | Displays status of point 71.  |
| 98           | FB MAX.S       | Displays status of point 72.  |
| 99           | ERROR STATUS   | Not used.   |