



AF-60 LP™

■ AF-60 LP™ IP21/Nema 1 Kit Mounting Instruction

Step 1

Fit top cover on drive

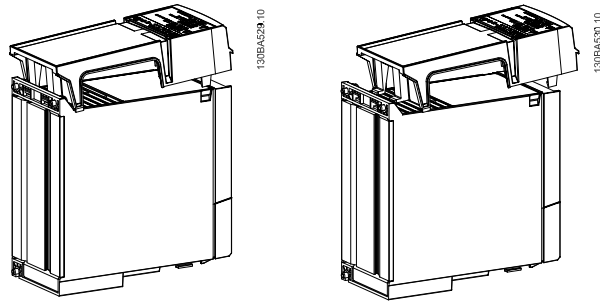

Step 2

Remove knockouts on metal plate and fit rubber gromets.

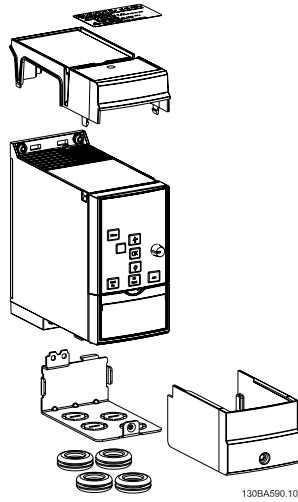

Step 3

Mount metal plate on drive and tighten screws. Tightening torque: 2 Nm

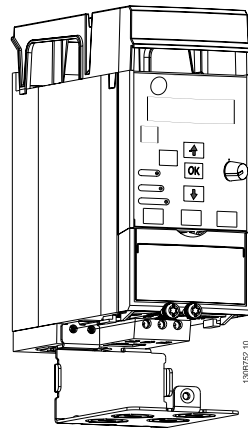

Step 4

Fit bottom cover on drive and tighten screw.

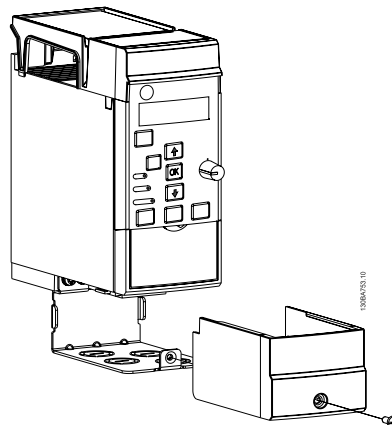

NOTE!
 For Nema 1 applications only the bottom cover is required. For IP21 applications both the top cover and bottom cover are required and keypad must be mounted to drive.

The instructions do not purport to cover all details or variations in equipment nor to provide for every possible contingency to be met in connection with installation, operation or maintenance. Should further information be desired or should particular problems arise which are not covered sufficiently for the purchaser's purposes, the matter should be referred to the GE company.

AF-60 LP are trademarks of the General Electric Company.

GE Consumer & Industrial
41 Woodford Avenue
Plainville, CT 06062

www.geelectrical.com/drives



132R0035

imagination at work



* M I Q 2 K 1 Q 2 *

DET-641