

- Variable Air Volume Ventilation Systems..... 3
 - Application.....3
 - Traditional Design.....3
 - Adjustable frequency drives.....4
 - Specific energy consumption.....5
 - Annual operation load profile.....5
 - Energy savings calculation example.....5
 - Sensor placement.....6
 - Danfoss VLT adjustable frequency drives.....7

- Single Zone Constant Air Volume Ventilation Systems...9
 - Application.....9
 - Traditional design.....9
 - Adjustable frequency drives.....10
 - Annual operation load profile.....11
 - Energy saving calculation example.....11
 - Energy consumption.....11
 - Sensor placement.....12
 - Comparison of installation and
maintenance costs.....12
 - Danfoss VLT adjustable frequency drives.....12

- Fan Control on Cooling Towers..... 14
 - Application.....14
 - Traditional design.....14
 - Adjustable frequency drives.....15
 - Annual operation load profile.....16
 - Energy savings calculation example.....16
 - Sensor placement.....16
 - Comparison of installation and
maintenance costs.....16
 - Danfoss VLT adjustable frequency drives.....17

- Condenser Water Pumping Systems..... 18
 - Application.....18
 - Traditional design.....18
 - Adjustable frequency drives.....19
 - Retrofit chiller applications.....20
 - Annual operation load profile.....20
 - Energy savings calculation examples.....21
 - Sensor placement.....21
 - Comparison of installation and maintenance costs.....21
 - Danfoss VLT adjustable frequency drives.....22

- Primary Pumps in a Primary/Secondary
Chilled Water Pumping Systems.....23
 - Application.....23
 - Traditional design.....23
 - Adjustable frequency drives.....24
 - Savings Example.....24
 - Energy savings calculation example.....25
 - Sensor type and placement.....25

Comparison of installation and maintenance costs..... 26
Danfoss VLT adjustable frequency drives.....26
True Payback Calculation Example..... 26

■ Secondary Pumps in a Primary/Secondary
Chilled Water Pumping Systems.....27

Application.....27
Traditional design..... 27
Adjustable frequency drives.....28
Specific energy consumption.....29
Annual operation load profile..... 29
Energy savings calculation example..... 30
Sensor type and placement..... 31
Danfoss VLT adjustable frequency drives.....32

Variable Air Volume Ventilation Systems

■ Application

Variable air volume, or VAV, system air handling units (AHU) meet the ventilation and air temperature requirements in buildings by controlling AHU fan airflow capacity. The system is usually designed to maintain constant static pressure in the supply duct and a positive building static pressure by regulating the airflow of the supply and

return fans. Individual VAV boxes supply the conditioned space with a variable flow of constant temperature air. Central VAV systems are the most energy efficient method to condition buildings. The efficiency comes from using large, centralized chillers and boilers, and from other distribution and air handling components that optimize the amount of comfort conditioning provided.

■ Traditional design

VAV systems typically involve bringing outside air into AHUs where the air temperature and humidity is adjusted and controlled. Air is conducted across cooling and heating coils and into ductwork for distribution to air conditioned zones throughout the building. Individual VAV boxes control the supply of conditioned air into each zone (see figure 1).

A temperature sensor located in each zone modulates the VAV box damper to maintain a defined temperature setpoint. As the conditioned space temperature becomes satisfied, the VAV box damper modulates toward a closed position. As a result, the pressure in the ductwork begins to rise as VAV boxes move to restrict airflow.

Traditionally, inlet dampers, discharge dampers or

inlet guide vanes (IGV) are installed in the air handling units to modulate the fan capacity. These devices work by either creating resistance to the air entering the ductwork or by reducing the effectiveness of the fan. As more VAV boxes in the system approach minimum flow, the AHU dampers throttle closed to maintain a constant duct static pressure and a positive building static pressure. The dampers or IGVs for the supply and return fans are commonly operated by individual controllers. The controllers maintain a fixed static pressure in the supply ductwork after the supply fan, as well as a fixed differential airflow between the supply and return systems to control building pressurization. While maintaining design conditions, these devices do little to conserve energy.

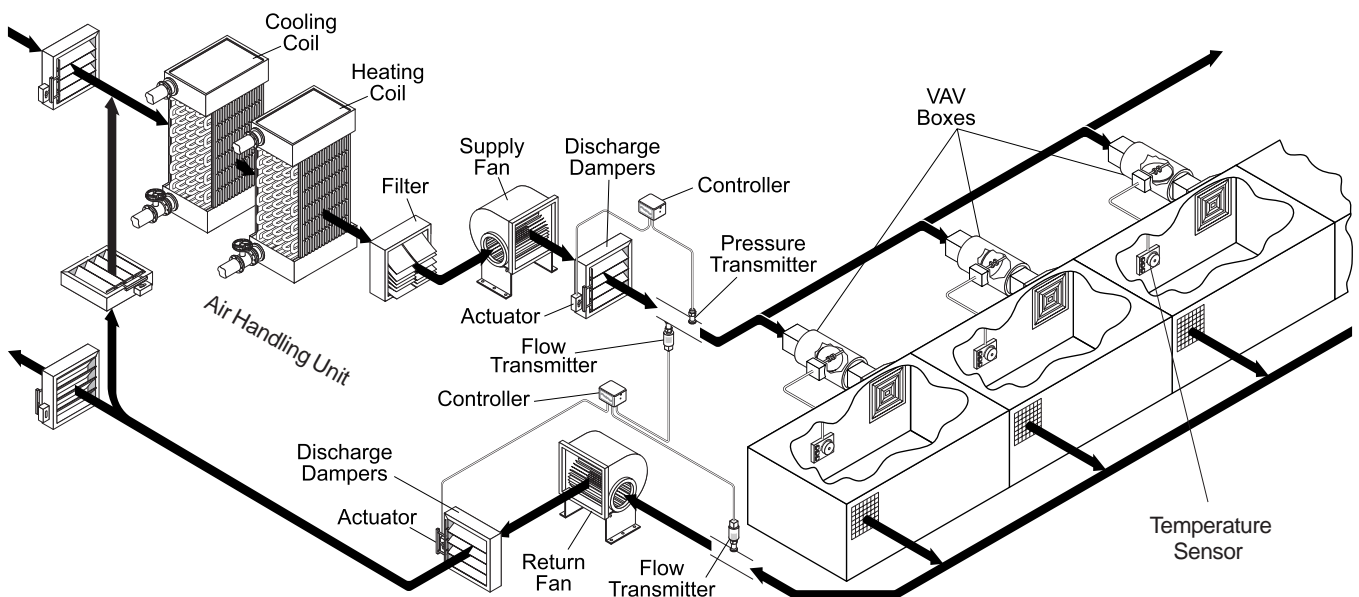

Figure 1. Traditional VAV Ventilation System

Adjustable frequency drives

An adjustable frequency drive can reduce complexity, improve system control, and save energy. Instead of creating an artificial pressure drop with dampers, or causing a decrease in fan effectiveness with IGVs, the drive controls the speed of the fan and fan capacity directly (see figure 2). Varying the supply or return fan motor speed provides the precise airflow and pressure required to fully satisfy the system. With adjustable frequency drives, oversized fans are easily corrected and balancing the system is simplified.

An adjustable frequency drive with a built-in PID controller provides accurate fan control and eliminates the need for external controllers. And, since the drive controls fan speed electronically, maintenance and cost related to mechanical control devices are eliminated.

Fan efficiency decreases when using discharge dampers or IGVs, but when using an adjustable frequency drive, the efficiency of the fan remains high, resulting in additional savings (see figures 3 and 4). Due to the ratio between airflow and power consumption in the fans, even a relatively minor reduction in flow results in significant energy savings.

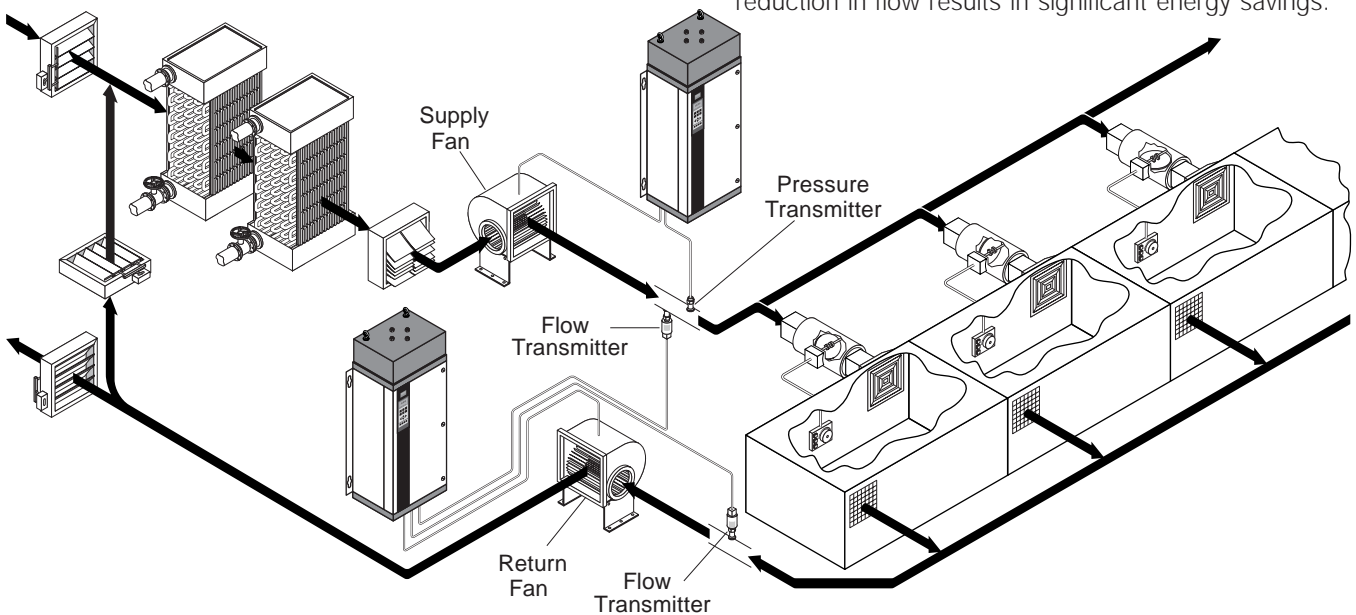
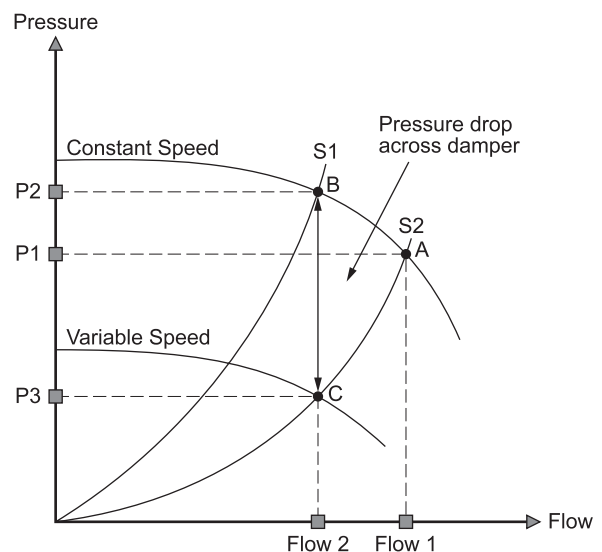

Figure 2. VAV System with Adjustable Frequency Drives

Figure 3 shows graphically the difference between operating at constant speed with a discharge damper and operating with an adjustable frequency drive. Full design operation, point A, is only necessary a small percentage of the time. The majority of the time, the flow rate required is lower. As the system's flow rate requirements decrease to Flow 2, at constant speed the system curve moves up the fan curve to point B. The pressure generated by the fan at this operation point, P2, is more than the system requires. The difference must be absorbed by the dampers. For variable speed operation, the fan curve moves along the system curve. The new operating point C is established. The pressure now generated, P3, is what the system requires. Since the power consumed by the fan is proportional to the flow times the pressure divided by the fan efficiency, the pressure difference between points B and C results in a significant energy savings.



$$\frac{\text{Flow} \times \text{Pressure}}{\text{Fan efficiency}}$$

Figure 3. Outlet Damper vs. Variable Speed

Specific energy consumption

Figure 4 shows the specific energy consumption of several control methods for variable air volume flow. Graph 1 shows the theoretical energy consumption according to the basic fan laws. Graph 2 shows the operational performance of an adjustable frequency drive. Graphs 3 and 4 are 2-speed motors (half/full speed and two-thirds/full speed) with damper. Graph 5 is a fixed speed motor with inlet guide vanes. Graph 6 is a fixed speed motor with an outlet damper.

The adjustable frequency drive most closely approximates the energy consumption of the fan laws for the greatest energy efficiency.

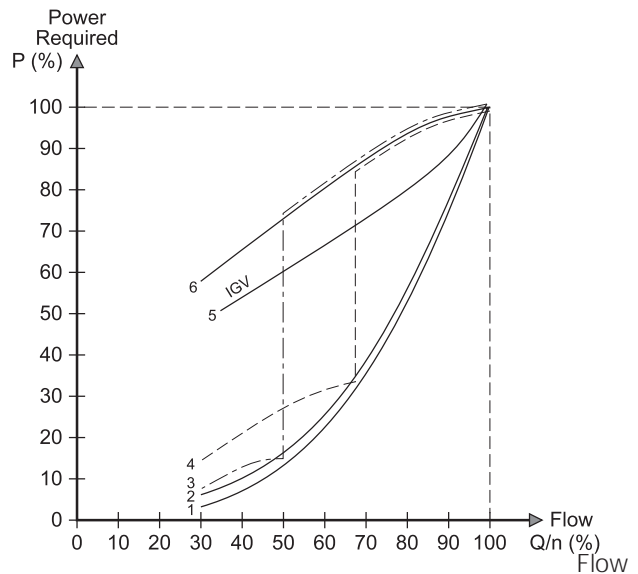

Figure 4. Power Requirements

Annual operation load profile

To calculate potential savings, look at the actual load profile. The load profile indicates the amount of flow the system requires to satisfy its loads during the day or time duration under study. Figure 5 shows a typical load profile for a VAV system. Profiles vary depending on the specific needs of each system.

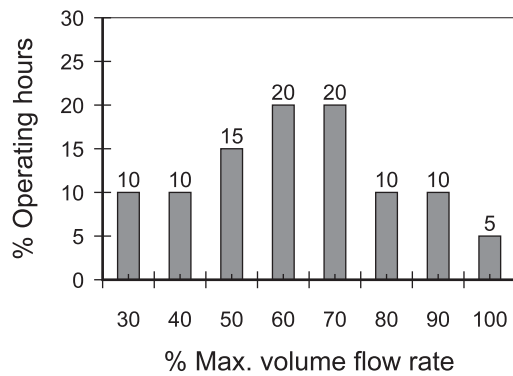

Figure 5. Operating Hours and Flow Rate

Energy savings calculation example

In the following calculation example, a 40 HP/30 kW fan is operated according to the load profile shown in figure 5. The energy consumption for one year is calculated for an AHU comparing the adjustable frequency drive with a 10% sensor setpoint to a discharge damper system. The result (see table below) shows that 116,070 kWh are saved in energy consumption using an adjustable frequency drive. That is a very significant 55% energy savings.

Energy Savings Table

Flow (%)	Hours (%)	Hours run	Electrical Power Required (kW)		Energy Consumption for 40 HP Fan Motor	
			Dampers	VLT	Dampers	VLT
30	10%	876	18	2	15,768	1,752
40	10%	876	19	3	16,644	2,628
50	15%	1314	21	5	27,594	6,570
60	20%	1752	24	8	42,048	14,016
70	20%	1752	26	11	45,552	19,272
80	10%	876	27	17	23,652	14,892
90	10%	876	28	23	24,528	20,148
100	5%	438	30	31	13,140	13,578
	100%	8,760 hrs			208,926 kWh	92,856 kWh

■ **Sensor placement**

The energy savings capabilities of a properly installed adjustable frequency drive system are significant. However, the importance of sensor placement for these savings is easily overlooked. To achieve optimum energy savings, it is critical that sensors are placed in the system correctly.

For VAV systems, a pressure sensor should be placed roughly $\frac{2}{3}$ of the distance downstream from the supply fan in the ductwork. This placement (see figure 6a) takes advantage of the reduced resistance ducts have at lower flow rates. In turn, this allows maintaining a lower setpoint value and lower pressure at the fan discharge during low flow conditions.

The objective of the fan system is to maintain the minimum required static pressure at the inlet of the VAV boxes. This allows the VAV boxes to operate properly and distribute air evenly to the controlled zone. The fan's discharge pressure requirement is calculated by adding the static pressure required by the VAV boxes to the pressure drop expected in the ductwork at full flow. A safety margin is applied to compensate for unforeseen design modifications required during installation.

If the static pressure sensor is placed directly after the discharge of the supply fan (see figure 6b), then, to guarantee proper operation of the VAV boxes, the pressure drop in the duct for maximum flow conditions must be assumed. This requires the pressure setpoint to be equal to the design pressure of the fan (see figure 7a). As airflow is

reduced, the fan continues to produce high pressure even though the pressure loss in the ducts has been greatly reduced. More pressure is being supplied to the VAV boxes than necessary. While some energy is saved this way, the full energy saving potential is not realized. Over pressurization, which occurs at less than full flow, wastes energy.

With the static pressure sensor placed as close to the VAV boxes as the design allows, compensation for the actual pressure drop in the duct is realized. As a result, the fan produces only the pressure required by the VAV boxes, regardless of the flow. The minimum setpoint to meet the system demand represents tremendous potential energy savings (see figure 7b). Thus, proper sensor placement and setpoint reduction optimizes energy savings.

Figure 7 shows the impact sensor placement can have on energy savings. The lower the minimum setpoint, the slower the adjustable frequency drive can run the fan, saving increasing amounts of energy.

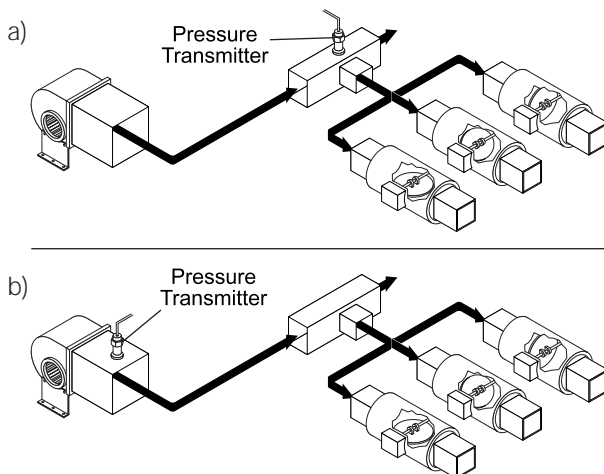
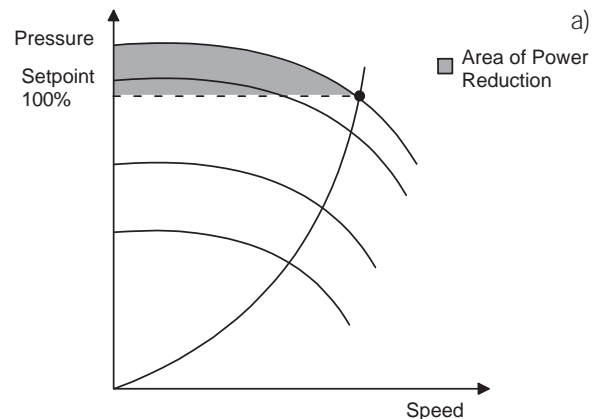
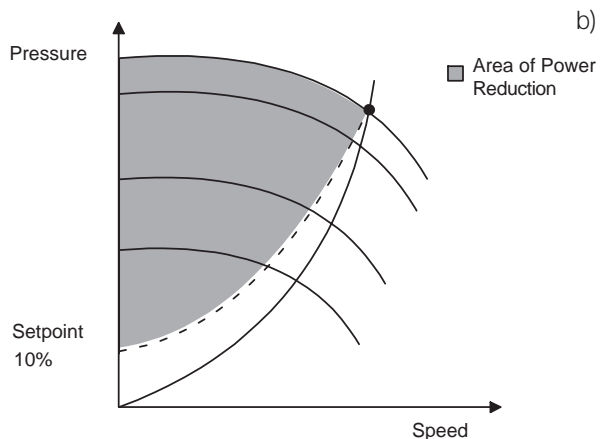

Figure 6. Pressure Transmitter Placement



Energy consumption with 100% setpoint
 Total energy consumption per year: 185,581 kWh
 Annual savings: (49,056 x \$ 0.10) **\$ 4,906**



Energy consumption with 10% setpoint
 Total energy consumption per year: 91,013 kWh
 Annual savings: (143,624 x \$ 0.10) **\$ 14,362**

Figure 7. Optimum Energy Savings

OEM air handling equipment with installed drives may already have the supply air pressure transmitter mounted in the fan discharge. While this arrangement forgoes much of the potential energy savings, it still provides major benefits of drive application. The maximum fan speed and load are easily limited. System commissioning and balancing are simplified. With pressure independent VAV terminal units, the resulting pressure variation at the VAV box inlet does not matter.

■ **Danfoss VLT adjustable frequency drives**

The Danfoss VLT® series adjustable frequency drives are designed with features tailored for energy efficiency and precision control. VLT series drives are the most effective means for fan control in VAV systems.

Single input PID controller

Closed loop control can be accomplished with the VLT 6000's internal PID controller. The PID controller maintains constant control of closed loop systems where regulated pressure, flow, temperature, or other system requirements must be maintained. The VLT 6000 offers 38 units of measure for the feedback signal for unequalled HVAC system flexibility. Feedback and setpoint values are programmed and displayed using the selected unit. Because the VLT 6000 is designed specifically for HVAC applications, the drive can operate without dependence on a building automation system. This can eliminate the need for an additional PID controller and I/O modules.

Two input PID controller

Closed loop control with two input signals can be accomplished with the VLT 6000's internal PID controller. The VLT 6000 drive's PID controller accommodates two feedback signals from two different devices such as the flow transmitters. This feature can be employed to carry out the differential flow control function required by the return air fan in a typical "volume matching" control scheme shown in figure 2.

Two-setpoint PID controller

VLT 6000 drives accommodate two feedback signals and allows for two setpoints from two different devices. This unique feature allows regulating a system with different setpoint zones. The drive makes control decisions by comparing the two signals to optimize system performance. In figure 2, for example, two pressure transmitters could be applied to the VLT 6000 controlling the

supply fan capacity. This would allow placing pressure transmitters in each of two parallel supply duct runs and controlling to the "worst case" condition. The two pressure transmitters could then be placed further out in the system than is possible in the common supply duct before the branch. The benefit is improved energy conservation, as shown in figure 7.

Operation in open loop

In open loop systems, the reference signals do not effect operation of the drive but can be displayed for system status, as warnings, or as input data for a serial network.

Run permissive

The drive has the capability to accept a remote "system ready" signal prior to operation. This feature is useful for a wide range of applications. When selected, the drive will remain stopped until receiving permission to start. Run permissive ensures that dampers, exhaust fans, or other auxiliary equipment are in the proper state before the drive is allowed to start the motor. This can be especially important in retrofit applications to avoid tripping on high static pressure or rupturing ductwork should a damper fail.

Automatic derate

By default, the drive will issue an alarm and trip at over temperature. If *Autoderate and Warning* is selected, the drive will warn of the condition but continue to run and attempt to cool itself by first reducing its carrier frequency. Then, if necessary, it will reduce its output frequency. This allows the HVAC system to continue delivering a level of comfort while protecting the drive during unforeseen temporary overload conditions. In start up, this provides for rooftop installations where an idle unit, having reached a high internal temperature due to the sun, is started. The VLT 6000 will start at limited speed for self-protection, if necessary, until the resulting air circulation lowers the internal temperature. With the restoration of adequate cooling, the drive will automatically resume normal operation.

Plenum mounting

VLT 6000 drives can be plenum mounted. The drives meet the UL requirements for installation in air handling compartments. The local keypad can be remotely mounted, providing drive control from a remote location. This feature makes the VLT 6000 suitable for rooftop units and AHU equipment where airflow stream mounting is the only possibility.

Frequency bypass

In some VAV applications (notably, AHUs employing vane axial fans), the system may have operational speeds that create a mechanical resonance. This can generate excessive noise and possibly damage mechanical components in the system. The drive has four programmable bypass frequency bandwidths. These allow the motor to step over speeds that induce system resonance.

Easy multiple drive programming

When a VAV project has many AHUs with VLT adjustable frequency drives, set up and programming is simplified. All drive parameters can be uploaded from the VLT drive to the removable display keypad. One programmed keypad can be used to quickly program other drives by downloading settings from the keypad to the additional drives. All keypads are identical, interchangeable and easy to remove.

Single Zone Constant Air Volume Ventilation Systems

■ Application

Constant air volume (CAV) systems are central ventilation systems common in older commercial buildings. They supply conditioned air to large areas such as in factories, schools, office buildings, warehouses, and shopping centers, and were popular prior to the introduction of variable air volume systems.

Single zone CAV systems typically use central air handling units to condition the air to meet building requirements. Multiple zone CAV systems can supply additional zones by using terminal mixing boxes or reheat to assist in conditioning and controlling the zones.

■ Traditional design

In traditional constant air volume systems, air is conducted across cooling and heating coils and into the building ductwork. A return fan may also be a part of the CAV system. The return fan extracts air from the conditioned zone back to the air handling unit (AHU) where it is either recirculated or exhausted outside. A temperature sensor in the return duct supplies signals to a controller for the heating and cooling coil valves. The valve controller regulates water flow to the coil to maintain the correct temperature in the conditioned space.

Traditional single zone CAV systems (see figure 1) are designed to flood an area with conditioned air. As with most HVAC systems, CAV systems are designed for “worst case” demands. As a result, they commonly waste energy relative to the needs of the building and do so for their entire operational life. No airflow modulation method for system control is used other than the original balancing of the system and control is limited to on/off.

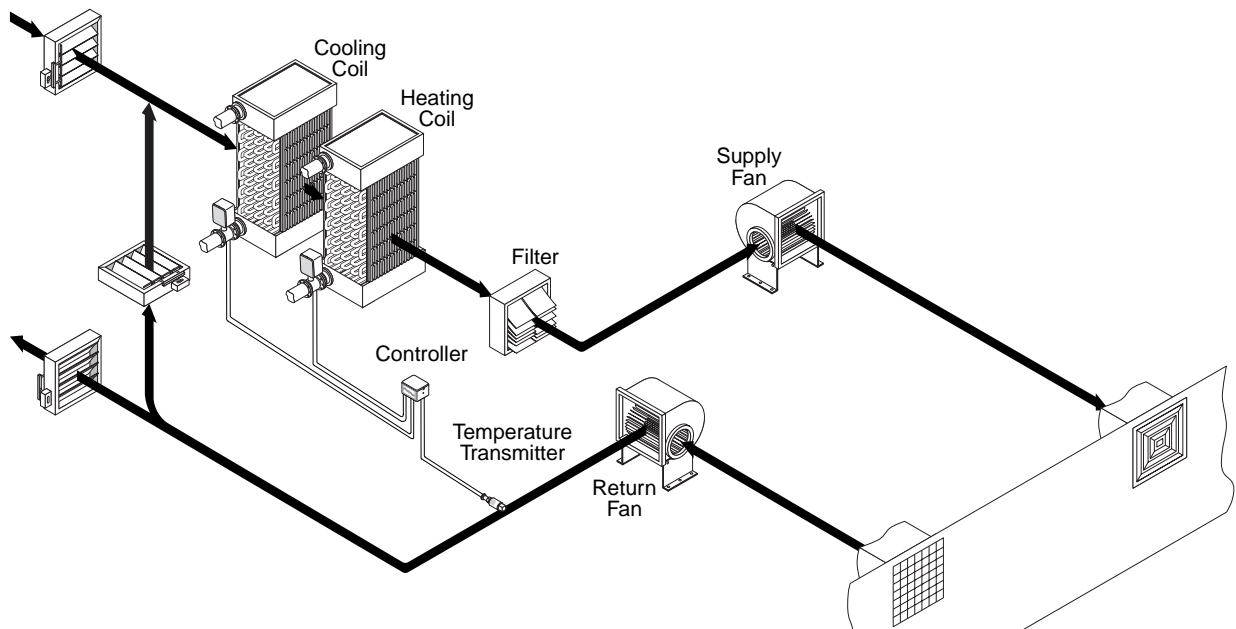

Figure 1. Single Zone CAV Ventilation System

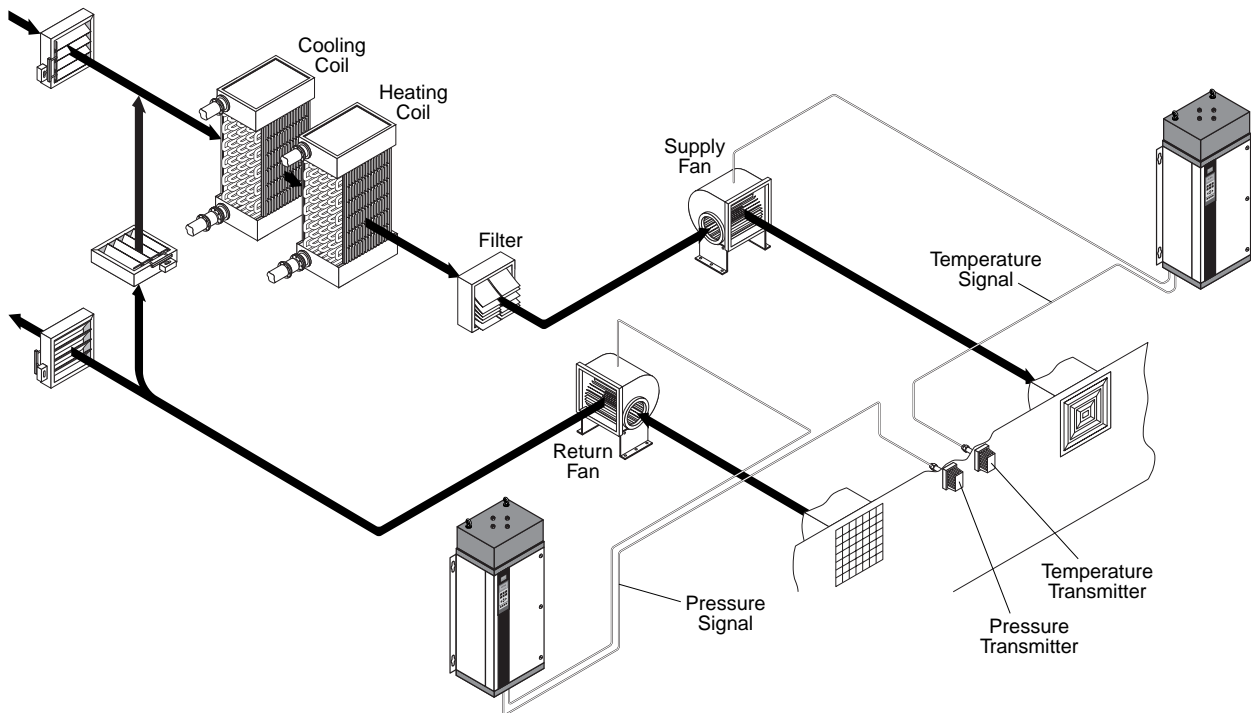

Figure 2. Single Zone CAV System with VLT Adjustable Frequency Drives

■ Adjustable frequency drives

With an adjustable frequency drive, significant energy savings are possible. An additional benefit is efficient regulation of the building's HVAC system. Temperature or CO₂ sensors can provide feedback signals to the drive. Whether controlling for temperature or air quality, the drive regulates the CAV system based upon the changing building conditions.

For example, when people leave a controlled area, the amount of fresh air needed is reduced. A sensor detects lower levels of CO₂ and, in response, the drive slows the supply fan's speed. A second drive (see figure 2), programmed to maintain either a room static pressure set point (referenced to outdoors) or a fixed differential between the supply and return air flow, modulates the speed of the return fan to maintain system balance.

In controlling for temperature, as the zone temperature satisfies the setpoint, the drive reduces the supply fan speed to decrease the airflow. The energy used to run the fan is reduced (see figure 3). Motor wear and maintenance costs are also reduced, adding further savings.

Air quality is an important element in controlling a ventilation system. By programming a minimum output frequency in the drive, a desired amount of supply air is maintained independent of the feedback or reference signal. The drive can maintain a minimum speed to ensure fresh air intake or a minimum pressure at the diffusers.

The return fan is frequently controlled to maintain a fixed differential in airflow between the supply and return. Adjustable frequency drives with an internal PID controller eliminate the need for an additional external controller. Feedback from a sensor in either voltage (0 to 10 V) or current (0 or 4 to 20 mA) is used by the drive to control fan speed.

■ **Energy consumption**

Figure 3 shows the specific energy consumption of regulation methods available for variable flow in a CAV system. Graph 1 shows the theoretical energy consumption according to the basic fan laws and represents the optimal theoretical operation. Graph 2 shows the performance of an adjustable frequency drive with a variable V/Hz ratio. Graphs 3 shows the operation of a full speed/half speed (4 pole/8 pole) motor. Graph 4 shows the operation of a full speed/two-thirds speed (4 pole/6 pole) motor. Graph 5 is full operation at full speed. The advantage of the adjustable frequency drive is clearly shown, as its energy consumption closely follows the optimal fan performance.

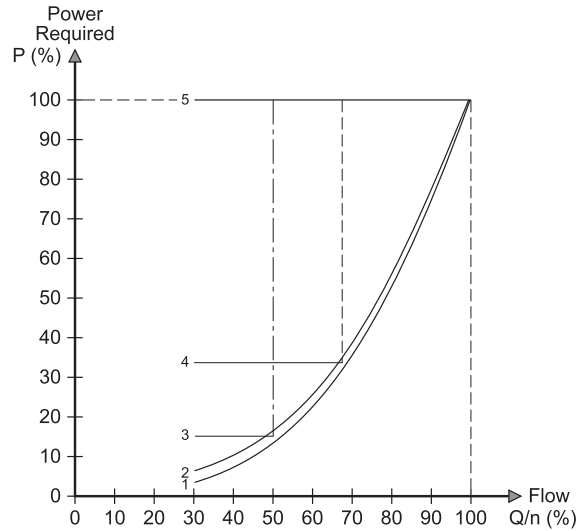

Figure 3: Variable Speed Pump Curves

■ **Annual operation load profile**

To calculate potential savings, look at the actual load profile. The load profile demonstrates the amount of flow the system requires to satisfy its loads during the day or time duration under study. Figure 4 shows a typical load profile for CAV systems. Profiles vary depending on the specific needs of each system, but this is representative of actual systems.

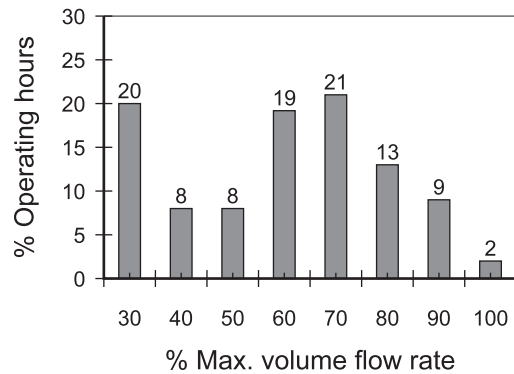

Figure 4. Operating Hours and Flow Rate

■ **Energy saving calculation example**

In the following calculation example, a 40 HP/30 kW fan is operated according to the load profile shown in figure 4. The energy consumption during one year's running time, shown in the table below, is calculated comparing an unregulated CAV system to a system controlled by an adjustable frequency drive. The comparison shows a real energy savings of more than 68% with an adjustable frequency drive, set for 30% minimum flow, compared to a constant speed fan.

Energy Savings Table

Flow (%)	Hours (%)	Hours run	Electrical Power Required (kW)		Energy Consumption for 40 HP Fan Motor	
			Unregulated	VLT	Unregulated	VLT
30	20	1752	28	1	49,056	1,752
40	8	701	28	2	19,622	1,402
50	8	701	28	4	19,622	2,803
60	19	1664	28	7	46,603	11,651
70	21	1840	28	11	51,509	20,236
80	13	1139	28	15	31,886	17,082
90	9	788	28	22	22,075	17,345
100	2	175	28	29	4,906	5,081
		100%	8760 hrs		245,280 kWh	77,351 kWh

■ Sensor placement

Proper sensor placement is important for peak system efficiency and to avoid potential problems with stratification and dumping in zone airflow control. Stratification occurs when the conditioned air, rather than mixing throughout the conditioned space, forms layers with the coolest air at the bottom. Dumping occurs when insufficient airflow causes the conditioned air to simply stream down from vents, again not mixing effectively within the conditioned space.

For best results, the adjustable frequency drive sensor should be placed in the zone at the occupied level and away from the diffuser. Another optional placement is to locate the transmitter in the return duct.

In CAV systems retrofitted with adjustable frequency drives, relocation of the temperature sensor for the AHU valve controller is important. The zone temperature will now be satisfied by the airflow rate in the system. Airflow is variable and controlled by the fan speed, which is regulated by the drive. The valve control sensor must be located in the supply side ductwork downstream from the supply fan. In this way, the heating and cooling coils will maintain a constant supply air temperature and the system will now deliver a variable flow of constant temperature air to the conditioned space. If the valve control sensor remains in the return duct, two separate control loops could attempt to control the same space temperature and hunting can occur wherein the valve controller tries to offset the variable system flow to maintain space temperature.

■ Comparison of installation and maintenance costs

Retrofitting an older CAV system with an adjustable frequency drive is economical and can result in significant energy savings. In addition to on-going energy savings, the drive practically pays for itself in installation and maintenance savings. Adjustable frequency drives eliminate the need for additional electrical components such as a soft-starter, additional motor cables, and power factor correction capacitors. Not only does this reduce the cost of upgrading a system, it also simplifies installation and maintenance. The soft-start inherent in variable speed drives eliminates high starting currents and reduces stress on the motors and bearings.

Designed for HVAC applications, the drive is capable of stand alone operation and has built-in serial communications capability for integration into a building automation system. Quieter system operation, an important feature in many applications, is an additional benefit in VLT controlled CAV air handling systems.

■ Danfoss VLT adjustable frequency drives

The Danfoss VLT® series adjustable frequency drives are designed with features tailored for energy efficiency and precision control. VLT series drives are the most effective means for fan control in CAV systems.

Single input PID controller

Closed loop control can be accomplished with the VLT's internal PID controller. The PID controller maintains constant control of closed loop systems where regulated pressure, flow, temperature, or other system requirements must be maintained. The VLT 6000 offers 38 units of measure for the feedback signal for unequalled HVAC system flexibility. Feedback and set point values are programmed and displayed using the selected unit. The drive can operate without dependence on a building automation system. This standalone capability can eliminate the need for an additional PID controller and I/O modules.

Two input PID controller

Closed loop control with two input signals can be accomplished with the VLT 6000's internal PID controller. The drive's PID controller accommodates two feedback signals from two different devices, such as two temperature transmitters in a large

auditorium. This feature can also carry out the differential flow control required by the return air fan in a typical “volume matching” control scheme.

Two set point PID controller

VLT 6000 drives accommodate two feedback signals from two different devices and allows for two set points. This unique feature allows regulating a system with different set point zones. The drive makes control decisions by comparing the two signals to optimize system performance. In an open office area, for example, two temperature transmitters could be applied to the VLT 6000 controlling the supply fan capacity. This would allow placing temperature transmitters at each end of the office area and controlling to the “worst case” condition.

Run permissive

VLT drives have the capability to accept a remote “system ready” signal prior to operation. This feature is useful for a wide range of applications. When selected, the drive will remain stopped until receiving permission to start. Run permissive ensures that dampers, exhaust fans, or other auxiliary equipment are in the proper state before the drive is allowed to start the motor. This can be especially important in retrofit applications to avoid tripping on high static pressure or splitting the ductwork in the event of a damper failure.

Automatic derate

By default, the VLT drive will issue an alarm and trip at over temperature. If *Autoderate and Warning* is selected, the drive will warn of the condition but continue to run and attempt to cool itself by first reducing its carrier frequency. Then, if necessary, it will reduce its output frequency. This allows the HVAC system to continue delivering a level of comfort conditions while protecting the motor and drive during unforeseen temporary overload conditions. This can allow for the rooftop situation where an idle unit that has reached a high internal temperature, due to sun radiation, is suddenly started. The drive will operate at a limited speed for self-protection, if necessary, until the resulting air circulation has brought the internal temperature down. With the restoration of adequate cooling air, the drive will automatically resume normal operation.

Plenum mounting

VLT 6000 drives can be plenum mounted. The drives meet the UL requirements for installation in air handling compartments. The local keypad can be remotely mounted, providing drive control from a remote location. This feature makes the VLT 6000 suitable for rooftop units and AHU equipment where airflow stream mounting is the only possibility.

Frequency bypass

In some VAV applications (notably, AHUs employing vane axial fans), the system may have operational speeds that create a mechanical resonance. This can generate excessive noise and possibly damage mechanical components in the system. The drive has four programmable bypass frequency bandwidths. These allow the motor to step over speeds that induce system resonance.

Minimum frequency

VLT drives can be set with a minimum output frequency to ensure an adequate air supply at low system demand. This can prevent damage to building areas not in current use, such as hotel banquet rooms or auditorium areas. It also counters “sick building syndrome” by supplying airflow to replenish occupied areas.

Building automation input

Temperature or other sensor data supplied to VLT drives can be exported to building automation systems to provide information without additional equipment.

Fan Control on Cooling Towers

■ Application

In large commercial structures with cooling towers for air conditioning, the cooling tower fan regulates condenser water temperature in water cooled chiller systems. The fan provides moving air to cool the water through evaporation. Warm water pumped from the chiller's condenser cascades through or is sprayed into the cooling tower fill area to increase its surface exposure and discharge heat. The tower fan blows air through the water in

the fill to increase evaporation. The cooled water collects at the bottom of the tower in the basin. From there it is pumped back through the chiller's condenser by the condenser water pump.

Water cooled chillers are common and highly efficient. They are as much as 20% more efficient than air cooled chillers. In many climates, cooling towers provide the most energy efficient method of removing heat from the chiller's condenser water.

■ Traditional design

Traditional cooling tower fan control systems (see figure 1) attempt to conserve energy and improve control through on/off fan operation, two speed motors, and sometimes adjustable-pitch fan blades. Two speed motors are limited in their capability to respond to system needs. While adjustable-pitch fan blades can offer more precise temperature control, the mechanism to regulate the blades can be expensive and a maintenance burden. On/off control, while severely limited in single-cell towers, is more effective with multiple-cell towers. Based

on the temperature of the condenser water leaving the basin, additional cells can be cycled on or off. However, to limit the number of times the fan motors are cycled, wide temperature bands are established, limiting system response and adding complexity.

The cooling tower's operation profile is determined by the system load on the chiller and the outside wetbulb temperature (a temperature reading that includes evaporation and humidity). As the wetbulb temperature or system load decreases, the cooling tower provides more cooling than necessary, wasting energy.

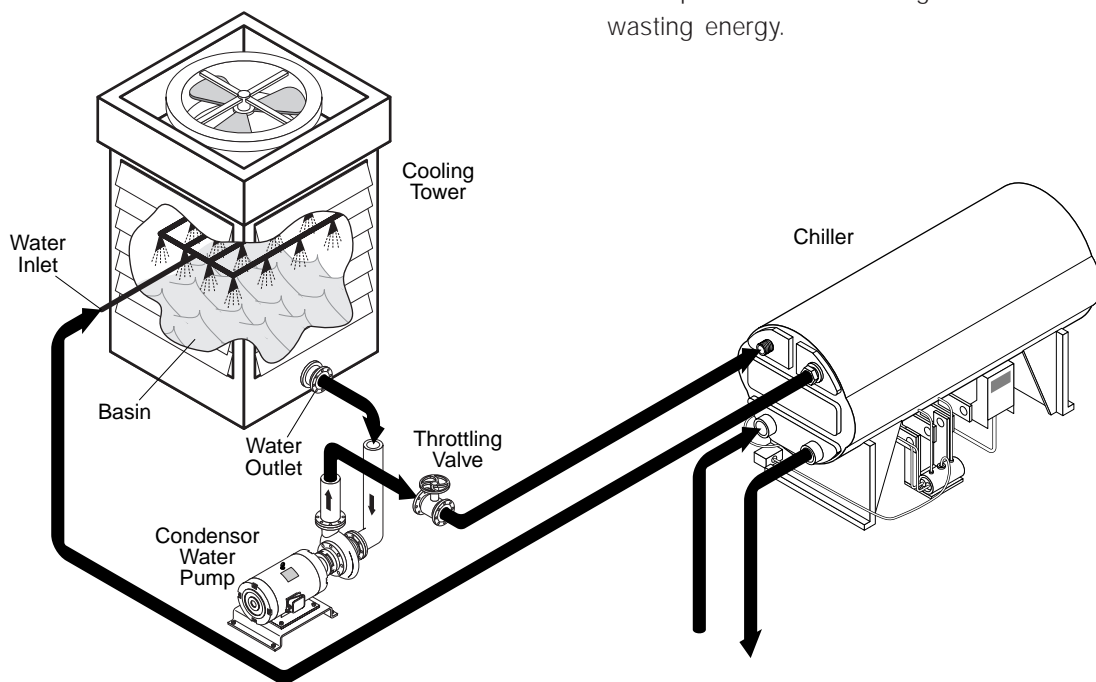

Figure 1. Cooling Tower Chiller Condenser System

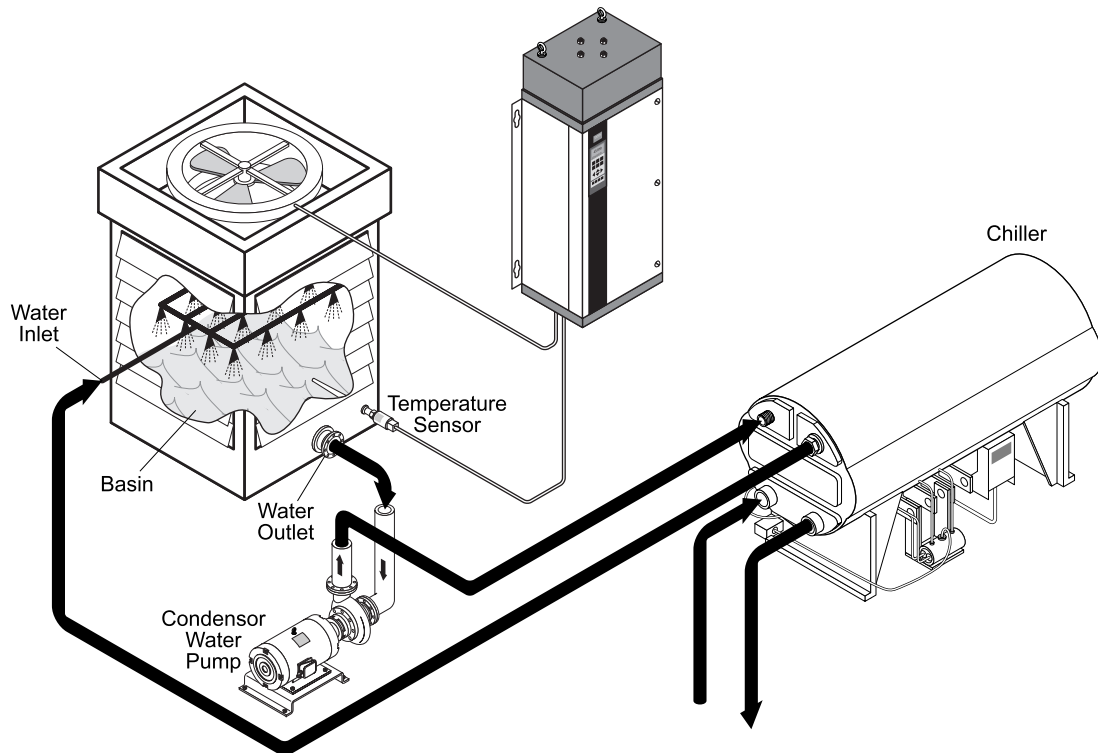

Figure 2. Cooling Tower Chiller Condenser System with Adjustable Frequency Drive

■ **Adjustable frequency drives**

With an adjustable frequency drive (see figure 2), the cooling tower fan is controlled in direct response to the condenser water temperature. The drive controls the exact fan speed required for cooling. Since the energy consumption of a cooling tower fan varies by the cube of its speed, even small reductions in motor speed have significant potential energy savings.

As the cooling tower fan drops below a certain speed, the fan becomes ineffective in cooling the water. With a gearbox in the tower fan, a minimum speed of 40% may be required to ensure proper lubrication of the gearbox. An adjustable frequency drive may have a customer programmable minimum frequency setting available to maintain this minimum speed.

Cooling tower fans are inherently noisy, which can be a problem in many applications. A tower fan controlled by an adjustable frequency drive operates well below maximum load much of the time (see figure 3). Therefore, a tower with capacity controlled by a variable frequency drive reduces what can be a serious concern.

Cooling towers and other comfort conditioning building equipment are often selected based upon full building occupancy. However, it may be years before all new construction space is completed and occupied. Tenancy in buildings may be subject to change as well, with sections unoccupied. During periods of low capacity operation, the adjustable frequency drive provides a convenient means of reducing the capacity of a cooling tower until full capability is needed – saving energy all the while.

Using drives with an internal PID controller and the multiple digital and analog outputs, additional equipment can be staged on and off, as needed. And, with serial communication software, the drive acts as a terminal on building automation systems by responding to system commands over a network.

■ **Annual operation load profile**

To calculate potential savings, look at the actual load profile. The load profile indicates the amount of flow the system requires to satisfy its loads during the day or time duration under study. Figure 3 shows a typical load profile for a cooling tower. Profiles vary based on the specific needs of each system, but the example represents actual systems.

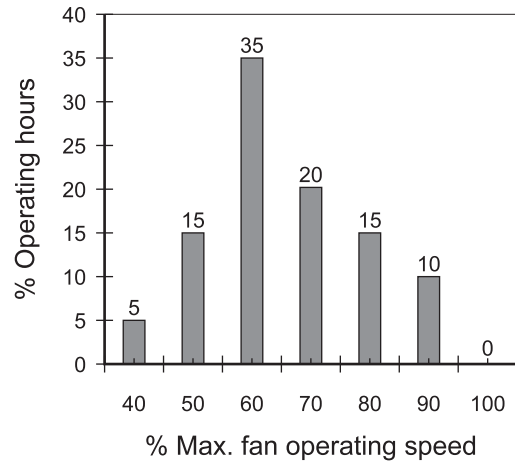

Figure 3. Operating Hours and Flow Rate

■ **Energy savings calculation example**

In the calculation shown in the table below, a 40 HP/30 kW fan motor is operated according to the load profile shown in figure 3. The energy consumption in one year is calculated for a cooling tower fan with a 2-speed motor (2/3 and full speed) compared with an adjustable frequency drive. The comparison shows energy savings of 53.5% with an adjustable frequency drive across all operational requirements.

Energy Savings Table

Flow (%)	Hours (%)	Hours run	Electrical Power Required (kW)		Energy Consumption for 40 HP Fan Motor	
			2-speed motor	VLT	2-speed motor	VLT
40	5	438	12.80	2.67	5,606	1,169
50	15	1314	12.80	4.83	16,819	6,347
60	35	3066	12.80	7.85	39,245	24,068
70	20	1752	30.00	11.93	52,560	20,901
80	15	1314	30.00	17.27	39,420	22,693
90	10	876	30.00	24.16	26,280	21,164
100	0	0	0.00	0.00	0	0
100%		8,760 hrs			179,930 kWh	96,342 kWh

■ **Sensor placement**

The energy saving capabilities of a properly installed adjustable frequency drive system are clear. In cooling towers, sensor placement and feedback control are simple in most systems. The temperature sensor should be located in the tower collection basin or on the condenser pump return line.

The ideal temperature is different in each installation and should be calculated. The efficiency of a water cooled chiller varies with the temperature of the return condenser water—the cooler the return water, the more efficient the chiller, within the design limits of the chiller. However, the energy consumption of the chiller needs to be compared to the energy consumption of both the tower fan and condenser pump to optimize system efficiency.

Once the optimum temperature has been determined, the drive can maintain this temperature as the system's loads and conditions

■ **Comparison of installation and maintenance costs**

The 2-speed fan motor system requires a pole changing motor, a suitable switchgear, 6-wire motor cable and power factor correction. A controller is necessary to switch speeds. Frequent switching from one speed to another must be avoided.

An adjustable frequency drive eliminates the need for the controller, power factor correction and extensive cablework. Feedback from a temperature sensor as either voltage (0 to 10 V) or current (0 or 4 to 20 mA) is sufficient to manage the fan speed.

Eliminating the high starting currents and peaks, created when 2-speed motors change speed, saves additional energy. Stresses on the motor, bearings and belt-drives are greatly reduced, as is maintenance and installation costs. Space savings and overall system simplification can also be considerations.

■ Danfoss VLT adjustable frequency drives

The standard features of Danfoss VLT® adjustable frequency drives can improve the performance and reduce operational costs of cooling tower fans.

No motor derating

The Danfoss VLT 6000 eliminates the need to derate the cooling tower fan motor. The VLT's unique Voltage Vector Control Plus (VVC+) provides a nearly sinusoidal output current waveform. This provides optimum motor magnetization. There is never a need to derate the motor for full speed, full load applications or for any operational speed. The maximum output voltage of the VLT 6000 drive at full speed and load can equal the input voltage. Its exact value is not dependent on the line or the DC bus voltage. Instead, it will precisely equal the user defined output voltage established during setup. Even if the input line is up to 10% below the desired output voltage, the desired output torque will be maintained. With the VVC+ feature, there is no longer a need to increase the size of the fan motor to accommodate the 10-15% service factor loss required by other drives. That means a potential "first cost" savings by avoiding larger motors with the Danfoss adjustable frequency drive.

Minimum frequency

VLT drives can be set with a minimum output frequency to ensure effective slow speed fan operation for adequate lubrication for the tower fan gear box.

Motor soft start

The VLT drive supplies the right amount of current to the tower fan motor to overcome load inertia to bring the motor up to speed. This avoids full line power voltage being applied to a stationary or slow turning motor, which generates high current and heat. Benefits from this inherent soft start drive feature are reduced thermal load and extended motor life, reduced mechanical stress on the system, and quieter system operation, an important consideration in some applications.

Frequency bypass

Cooling tower fans can have undesirable resonant frequencies that cause mechanical vibration in the tower. This can generate excessive noise and possibly damage mechanical components in the system. These frequencies can be easily avoided with Danfoss VLT drives by programming a bypass frequency range into the drive. The drive supports four programmable bypass frequency bandwidths. This allows the fan motor to step over speeds

which induce system resonance, offering resonant-free operation over a wide speed range and variable loads.

Sleep mode

VLT drives offer sleep mode, a feature which automatically stops the fan motor when demand is at a low level for a determined period of time. When the system demand increases, the drive restarts the motor to reach the required output. Sleep mode has great energy savings capability and reduces wear on driven equipment. Unlike a setback timer, the drive is always available to run when the preset "wake-up" demand is reached.

De-icing

Under some operating conditions, cooling towers can be subjected to icing. In many environments, condenser water must be supplied even when the outdoor ambient temperature approaches or is below freezing. Even with anti-freeze in the condenser water, the tower can experience ice build up at the inlet louvers and fill area due to atmospheric moisture. VLT drives have the ability to reverse the direction of the fan motor via a contact closure. This provides the capability to de-ice the tower by reversing the airflow, which passes air over the warmer water in the basin and exhausts it through the fill area and inlets, melting the frost accumulation.

Motor preheat

When a motor has to be started in a cold or damp environment, such as in a cooling tower, the VLT adjustable frequency drive can trickle a small amount of DC current into the motor continuously to protect it from condensation and the effects of a cold start. This can extend the operational life of the motor and eliminate the need for a space heater.

Condenser Water Pumping Systems

Application

Condenser water pumps circulate water through the condenser section of water cooled chillers and the associated cooling tower. These installations are commonly found in large air conditioning systems for applications such as airports, university campuses, hospitals, office towers and hotels. The

condenser water absorbs heat from the chiller's condenser. The condenser water pump forces the water to the cooling tower where the heat is released into the atmosphere. Water cooled chiller systems provide the most efficient means of creating chilled water and are as much as 20% more efficient than air cooled chillers.

Traditional design

Condenser water is cooled in the cooling tower by means of evaporation. The cooled water collects in the tower basin where it is then pumped through the chiller condenser (see figure 1).

In traditional system designs, the condenser water pump circulates the water continuously through the system at full flow. The temperature of the condenser water is controlled by the cooling tower fan control or bypass valve. The lower the return condenser water temperature to the chiller, the lower the energy consumption of the chiller, within the design limits of the chiller.

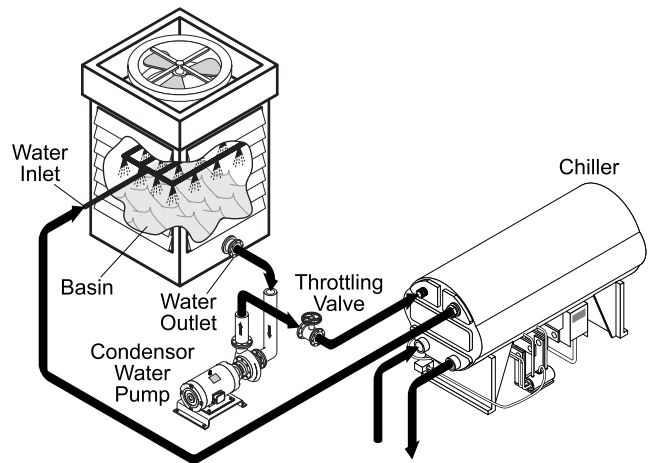

Figure 1. Traditional Condenser Pump System

The condenser pump is usually oversized for a safety margin and to compensate for scaling in the piping and chiller tubes. The system is balanced with a manual throttling valve to prevent too high a flow rate. Excess flow can erode the chiller's tubes, degrade system efficiency and increase maintenance expense. By adding resistance to the system with the throttling valve, the rate of flow is reduced to the design flow rate of the condenser (see figure 2).

Figure 2 shows the pressure that must be absorbed in a throttling (balancing) valve system as flow is controlled. Balancing the system changes water flow from Flow 1 to the design flow by following the pump curve. As a result, condenser water pumping pressure increases from P1 to P2. The pressure drop between P2 and P3 is absorbed by the throttling valve.

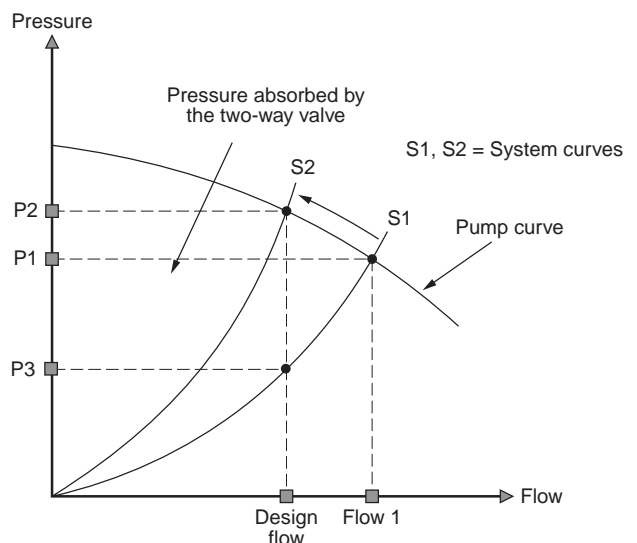

Figure 2. Throttling Valve Energy Loss

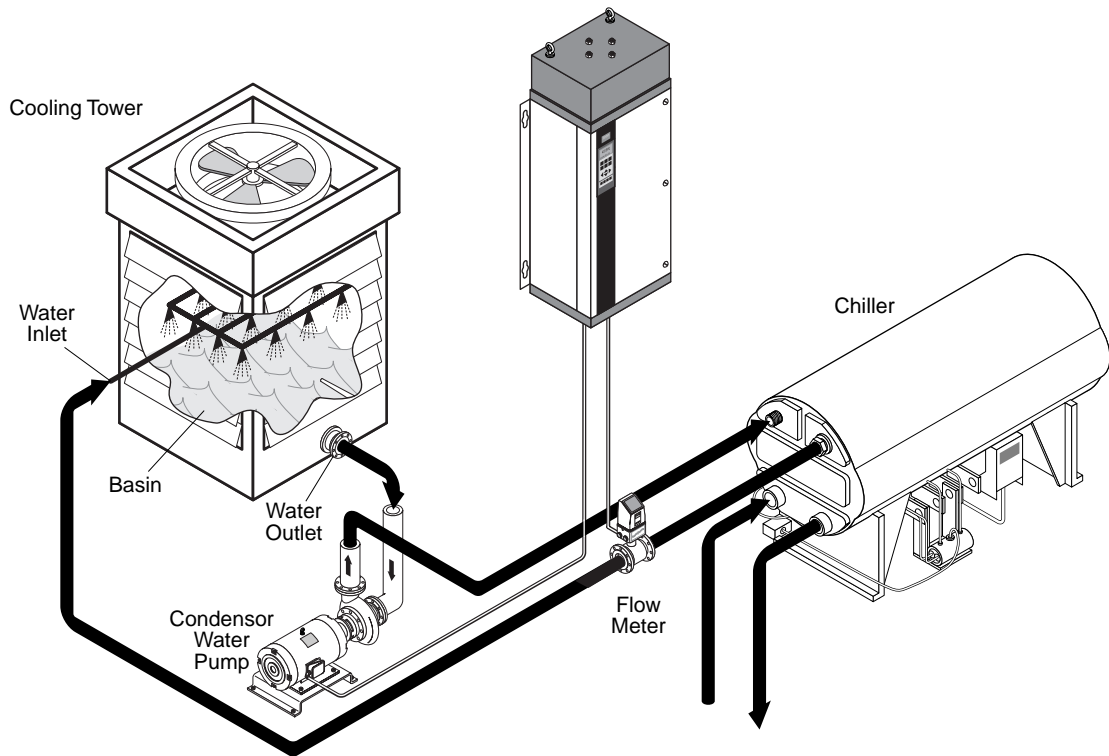

Figure 3. Condenser Pump System with an Adjustable Frequency Drive

■ Adjustable frequency drives

Adjustable frequency drives can control condenser water pumps without the need to balance the system with a throttling valve. Using a drive rather than a throttling valve saves the energy that would have been absorbed by the valve. Savings with an adjustable frequency drive can total 15% to 50% (or more) of energy consumed by the condenser pump.

Simple manual speed control of the drive can reduce the condenser water pump capacity, resulting in a constant speed and constant volume application. In figure 2, this is shown as the difference between operation at the design flow on the pump curve at pressure P2 and operation at the design flow on the system curve at pressure P3.

In figure 3, the adjustable frequency drive controls the speed of the pump employing a flow meter for feedback and closed loop control. By maintaining the design flow rate, the drive automatically compensates for scaling in the piping or chiller

tubes, increasing the pump output pressure as scale builds up.

To go beyond simple elimination of the balancing valve, closed loop control based on temperature feedback significantly increases energy savings. This variable speed, variable flow application not only saves the balancing valve energy loss but also allows the flow to decrease below the design flow, whenever the system load is less than design. Variable speed and variable flow closed loop control optimizes the pumping capacity to match the system heat rejection load. The result is a great improvement in energy conservation compared to 2-speed tower fan motors or tower bypass valves.

A drive is often used for condenser water pump control in installations where applying drives to the cooling tower fans for energy savings is difficult. This occurs when multiple towers return water to a common pump, making tower fan control impractical, or when the cooling tower location and drive mounting restrictions make it more convenient to apply the drive to the pump rather than the fan. The drive controlled condenser pump, with cooling

tower basin temperature feedback, maintains the appropriate basin water temperature by increasing or decreasing the discharge pressure and flow rate. In periods of low load, the tower cooling capacity is decreased and the design temperature is maintained. In spray systems, decreased pressure at the spray nozzle in the cooling tower reduces the spray volume and cooling capacity. Limitations due to spray nozzle requirements and control of “misting” are accommodated by selection of high and low limits for drive operation.

Using feedback from the temperature of the tower basin, the drive can also automatically compensate for the number of chillers in operation in systems with multiple chillers run in sequence.

With the cooling tower basin temperature controlled by the condenser pump drive, care must be taken to establish a minimum output for the drive to avoid laminar water flow in the condenser and the resulting chiller trip out due to low condenser flow or high condenser refrigerant pressure.

In some applications, it may be desirable to control the water temperature with speed control of both the cooling tower fan and the condenser pump. These include multiple tower installations, locations requiring air conditioning during winter months, and installations with free cooling or with significantly oversized chillers. In these circumstances, with fan control only, the environment can cause the water to over-cool, even when the fan is off.

Controlling both the fan and pump provides the greatest overall energy savings. This approach requires careful regulation of the fan drive and pump drive to avoid control loop conflicts wherein both drives attempt to control over the same temperature range.

Comfort conditioning equipment is often selected based upon full building occupancy. However, it may be years before all new construction space is completed and occupied. Building tenancy may be subject to change as well, with sections becoming unoccupied. During periods of low capacity operation, the adjustable frequency drive provides a convenient means to reduce the capacity of a cooling tower condenser pump until full capability is needed – saving energy all the while.

■ Retrofit chiller applications

Adjustable frequency drives can provide an optimized flow rate without requiring new pumps or throttling valves, reducing pump efficiency or adding the labor costs and system constraint caused by trimming the impeller.

On chiller retrofit applications, the potential for change in the design flow rate of the condenser water must be considered. Due to decreased flow requirements in replacement chillers, the drive may reduce the condenser flow rate by as much as 33%, often resulting in a 50% (or more) reduction in the previous system’s condenser pump energy consumption. (Consult the chiller manufacturer before varying the flow rate of the condenser pump.)

■ Annual operation load profile

A load profile demonstrates the amount of flow a system requires to satisfy its loads during the day or time duration under study. Figure 4 shows a typical load profile for a condenser water pump. Profiles vary depending on the specific needs of each system but the example represents actual systems. The minimum speed of the pump, 60% in this example, is selected to maintain turbulent flow through the condenser section and minimize condenser tube fouling.

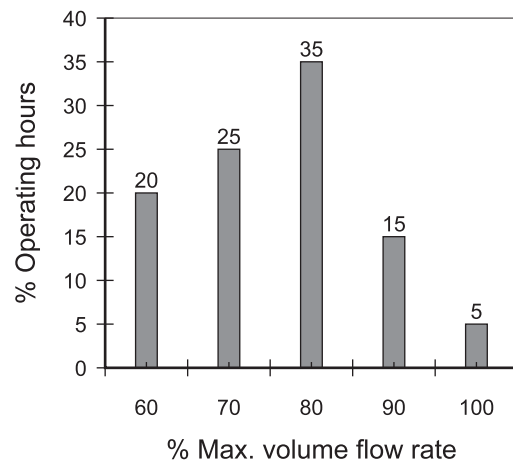

Figure 4. Operating Hours and Flow Rate

■ **Energy savings calculation examples**

Three comparisons are presented for a 40 HP/30 kW condenser water pump in the same system and load profile. The energy consumption during one year of operation at 100% is calculated for each. The comparisons are shown in figure 5.

In the first calculation, a 15% over-headed pump uses a discharge balancing valve to adjust the pump flow to the required system design flow. The pump operates at full speed, 100% of the time, at the P2 pressure and design flow, as shown in figure 2.

In the second situation, the balancing valve is removed and the pump is operated by an adjustable frequency drive at a reduced constant speed, adjusted manually (or via a flow meter as in figure 3) to again match the required system design flow. This results in pump operation at the intersection of P3 and the design flow, as shown in figure 2. The result is an annual energy savings of 33,969 kWh with the adjustable frequency drive compared to the balancing valve.

In the last comparison, an adjustable frequency drive operates in closed loop control based on the system load, by controlling temperature in the cooling tower basin. The system load profile is shown in figure 4. A minimum drive output to maintain at least 60% flow has been applied. The resulting variable speed operation saves 171,059 kWh annually compared to the balancing valve. Energy savings is better than 50%, even maintaining a 60% minimum speed.

■ **Sensor placement**

For temperature control of condenser water pumps, the sensor should be placed in either the cooling tower basin or in the return line. With flow meter applications, the meter should be placed in the discharge or inlet of the condenser section of the chiller.

There are two sensing and feedback techniques for direct monitoring of load changes on the chiller. Differential temperature at the chiller's condenser water inlet and discharge lines can be sensed, or condenser refrigerant pressure can be sensed directly for control, in cases where a refrigerant pressure transmitter connection is available.

■ **Comparison of installation and maintenance costs**

In addition to energy savings, the cost of using an adjustable frequency drive is partly paid back by the savings on installation and maintenance costs. The traditional system not only requires the balancing valve, but also needs a soft-starter, power factor correction capacitors, and additional motor cable.

With an adjustable frequency drive, the valves, soft-starters, power factor corrections, and extensive cablework are all unnecessary. A flow meter control signal, manual speed adjustment, or feedback from a temperature sensor, as either voltage (0 to 10 V) or current (0 or 4 to 20 mA), is sufficient to manage the motor and pump speed.

The comparisons of energy consumption, reduced maintenance, and precise system control show why an adjustable frequency drive is the most effective choice for controlling a condenser water pumping system.

Configuration	% Flow	% Hours	Run Hours	Power kW	Energy kWh
Discharge balancing valve, full speed pump	100	100	8,760	30	298,483
Adjustable frequency drive, reduced constant speed pump	100	100	8,760	25.22	264,514
Adjustable frequency drive at variable speed in closed loop control	60	20	1,752	5.45	12,613
	70	25	2,190	8.65	23,948
	80	35	3,066	12.91	48,542
	90	15	1,314	18.38	29,096
	100	5	438	25.22	1,326
Totals		100%	8,760		127,424

Figure 5. Energy Savings Example

■ Danfoss VLT adjustable frequency drives

The Danfoss VLT® series adjustable frequency drives are designed with features tailored for energy efficiency and precision control. VLT series drives are the most effective means for pump control in condenser water pumping systems.

Single input PID controller

Closed loop condenser pump control can be accomplished with the VLT's internal PID controller. The VLT 6000 can operate independent of a building automation system, eliminating the need for an additional PID controller and I/O modules. For the typical condenser water pumping application, a single feedback (input) signal from a temperature transmitter in the cooling tower water return line is all that is required. The feedback and set-point values, in this case, can be based upon temperature. The VLT 6000, however, offers 38 units of measure to display the feedback and setpoint signals for unequalled HVAC system flexibility.

Four programmable setups

The VLT adjustable frequency drives have four independent setups that can be programmed. Independent setups are used, for example, to change set-points, depending upon the number of active pumps and chillers in parallel operation. The active setup is displayed on the control panel. The setup data can be copied from drive to drive by downloading the information from the removable control panel. In multi-setup mode, it is possible to switch between setups through digital inputs or a serial interface.

In using multiple setups, the VLT 6000 can control both the cooling tower fan and the condenser pump in response to tower basin temperature feedback. The drive setups operate in sequence to prevent unstable control loops. One drive controls the cooling tower fan operation, from maximum load and speed to the minimum speed, for effective tower fan operation. During tower fan operation, the condenser pump drive maintains a fixed speed to produce the design flow of the condenser water. When the tower fan reaches minimum speed and stops, the setup on the condenser pump drive is changed to control the speed of the condenser pump. The condenser pump drive varies the condenser water flow in response to the system load, down to the selected minimum pump speed.

Minimum frequency

VLT series drives permit a minimum motor frequency limit to be set corresponding to the minimum speed at which the motor will be allowed to run. A minimum speed may be necessary to avoid laminar water flow in the condenser section of the chiller, preventing chiller trip out on high refrigerant pressure.

Power fluctuation performance and automatic restart

The Danfoss VLT drives withstand power line fluctuations such as transients, momentary dropouts, short voltage drops and surges. The drive automatically compensates for input voltages $\pm 10\%$ from the nominal to provide full rated motor torque. With auto restart selected, the drive will automatically power-up after a voltage trip. These features eliminate the need for manual reset of the drive. For remotely controlled systems, where having someone restart the drive manually is inconvenient or impractical, automated operation may be essential. And with flying start, the drive synchronizes to motor rotation prior to start.

High frequency warning

Useful in staging on additional pumps, the VLT adjustable frequency drive can warn when the motor speed reaches a specific high frequency setting entered into the drive. If the drive's output exceeds the set warning frequency, the drive displays a high frequency warning. A digital output from the drive can signal additional pumps to stage on.

High and low feedback warning

In closed loop operation, the selected high and low feedback values are monitored by the Danfoss VLT drive. The display shows a flashing high or flashing low warning, when appropriate. The warning condition may indicate system problems such as low condenser water flow or cooling tower failure.

Primary Pumps in a Primary/Secondary Chilled Water Pumping Systems

■ Application

Primary/secondary chilled water systems are generally used in commercial buildings to improve efficiency in large air cooling systems. The primary/secondary pumping system separates the primary production loop from the secondary distribution

loop. In the primary segment, pumps are used to maintain a constant flow. This allows the chillers and the primary production loop to maintain their constant design flow while allowing the secondary system to vary the flow based on cooling load demand.

■ Traditional design

In traditional chilled water systems, the primary loop consists of non-regulated pumps sized to produce the design flow rate of the chillers at a discharge pressure sufficient to circulate the water through the chillers and the primary loop. The primary loop is as small as possible while able to support the secondary system. This minimizes the resistance in the primary loop, and, therefore, the energy consumption of the constant-flow primary pumps.

parallel.

Flow from the primary pumps is traditionally adjusted by throttling or balancing valves on the discharge of the pump (see figure 1). The pumps are usually oversized due to the safety margin in the design and to accommodate future scaling in the pipework and chiller tubes. By creating flow loss in the pumping circuit with the throttling valve, the proper designed flow rate is established (see figure 2).

When the evaporator flow rate decreases in a chiller, as when the distribution side demand drops, the water in the evaporator section can become over-chilled. When this happens, the chiller will attempt to decrease its cooling capacity. If the flow rate drops too far or too quickly, the chiller cannot shed its load sufficiently. The chiller's low evaporator temperature safety will trip, requiring a manual reset of the chiller. This situation can be common, especially with two or more chillers installed in

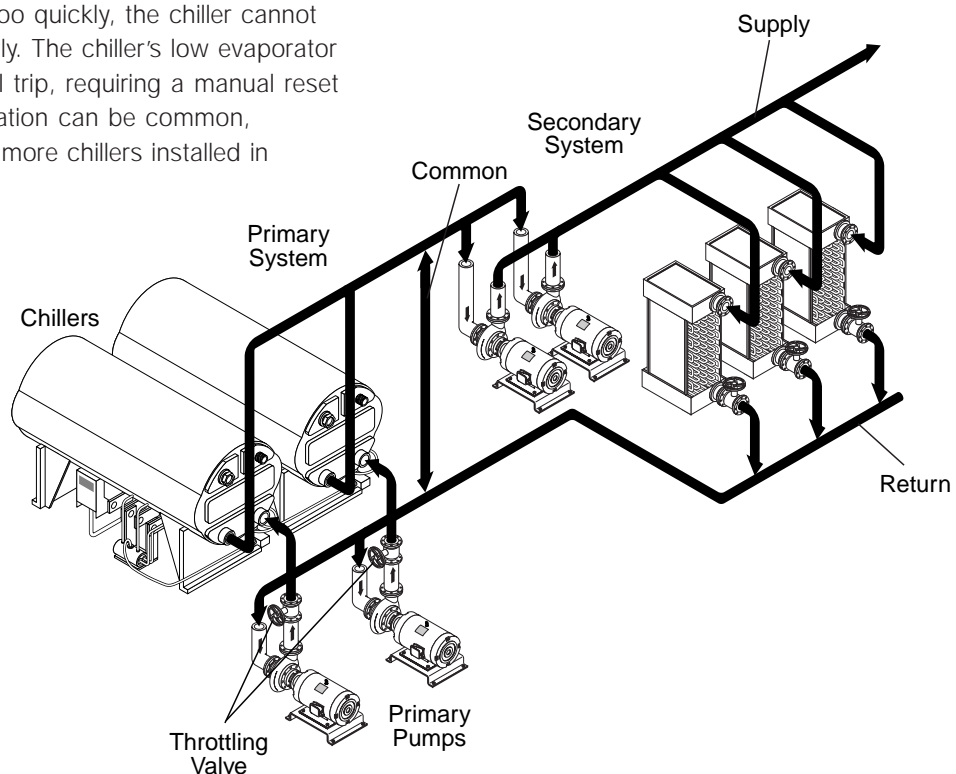

Figure 1. Traditional Primary/Secondary Pumping System Design

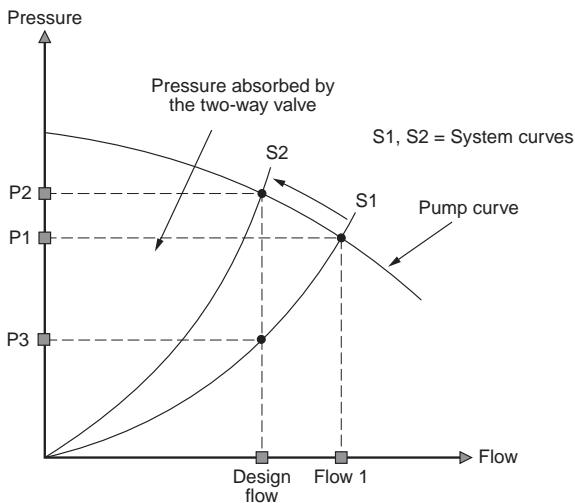

Figure 2. Throttling Valve Energy Loss

Figure 2 shows the pressure that must be absorbed in a throttling valve system to control flow. Balancing the system changes water flow from Flow 1 to the design flow. As a result, pumping pressure increases from P1 to P2. The pressure drop between P2 and P3 is absorbed by the throttling valve.

Another method to adjust primary pump flow is to trim the pump impeller. Once the system is operating, the actual pressure drop in the primary loop can be determined. The pump's impeller is removed, trimmed to the proper diameter, balanced, and reinstalled in the pump. Decreasing the diameter of the impeller reduces both the capacity and pressure capability of the pump, as desired, and has an impact on the pump's efficiency (see figure 3). The change, however, is fixed and permanent.

■ **Adjustable frequency drives**

Based on the size of the system, the energy consumption of the primary loop can be substantial. An adjustable frequency drive controlling the primary system pumps replaces the throttling valve and eliminates trimming the impellers. The result is greater energy efficiency and reduced maintenance and operating expense.

Two drive control methods are common. One method uses a feedback signal from a flow meter (see figure 4). Because the desired constant-flow rate is known, a flow meter installed at the discharge of each chiller monitors the pump output. An adjustable frequency drive with a built-in PID controller maintains the appropriate flow rate. The

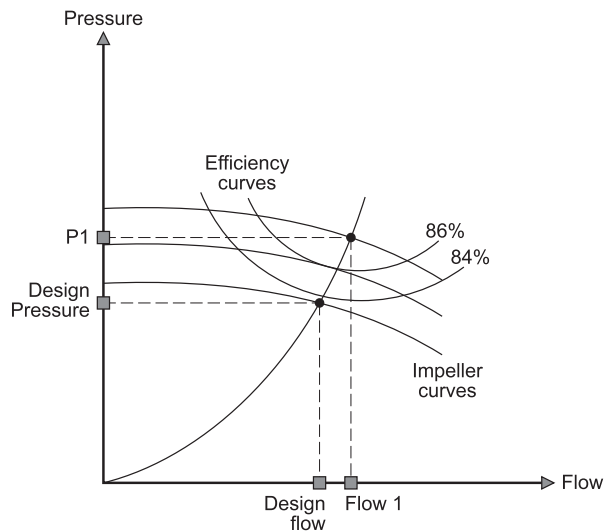

Figure 3. Pump Impeller Trimming

drive automatically compensates for scale buildup and for changing resistance in the primary loop as chillers and their pumps are staged on and off. Flow meter feedback for drive control minimizes chiller low evaporator temperature safety trip out and can eliminate manual reset in installations where parallel chiller operation makes this a concern.

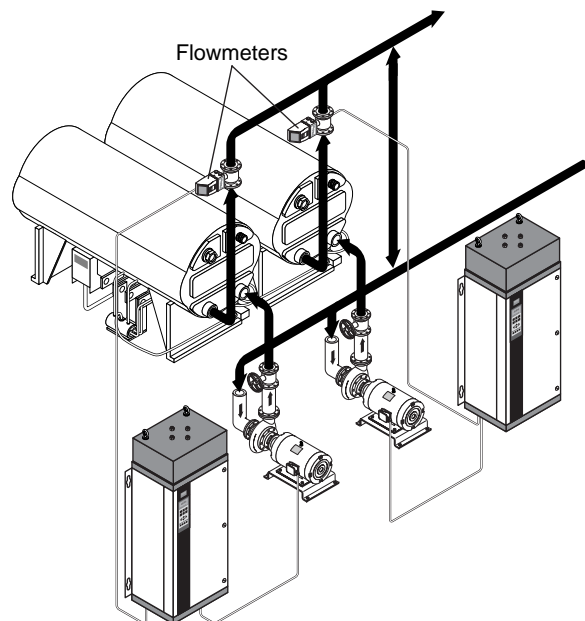

Figure 4. Adjustable Frequency Drives in Primary Pump Control

Local speed control is the other method. The operator can simply adjust the output frequency of the drive manually until the design flow rate is achieved. The pump operates at this constant speed any time the chiller is staged on. Using an adjustable frequency drive to decrease the pump's speed has the same effect as trimming the pump impeller, except it doesn't require any labor costs and the pump's efficiency remains higher (see figure 5).

The primary loop doesn't need control valves or other devices that can cause the system curve to change. And, since the variance due to staging pumps and chillers on and off is usually small, this fixed speed will remain appropriate for many installations. In the event the flow rate needs to be changed, due to scaling in the pipework or system modification, for example, the operator simply readjusts the drive output for efficient operation.

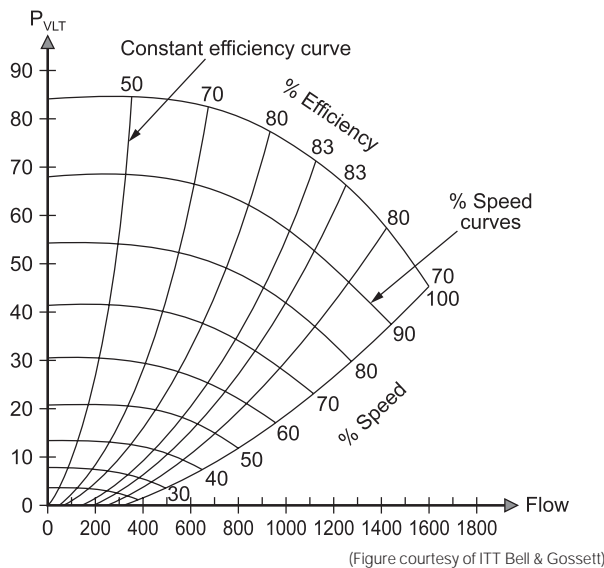

Figure 5. Pump Efficiencies with Variable Speed

Figure 5 shows that the pump efficiency remains constant as the speed is reduced to obtain the design flow. This differs from the results of trimming the impeller, where the efficiency decreases (refer to figure 3).

■ **Energy savings calculation example**

In the Savings Example below, the savings for operating a 40 HP/30 kW primary pump with an adjustable frequency drive are shown. For the purposes of the calculation, the pump's original design discharge pressure is assumed to be 15% overheaded.

Usually pumps are overheaded by 15% to 25% (or more) to compensate for possible installation variations and other safety factor calculations. For constant flow applications, this over-pressurization causes a proportional waste of energy. Using an adjustable frequency drive to balance the system rather than throttling valves eliminates otherwise wasted energy.

■ **Sensor type and placement**

The proper location for a flow meter used with an adjustable frequency drive is at the discharge of the chiller, assuming each chiller has a dedicated meter and drive. The flow meter can be installed at the inlet to the chiller, but the flow is more turbulent and may affect the accuracy of the meter.

On multi-chiller installations, using a drive with a flow meter on each chiller maintains the design flow rate through each chiller. This takes advantage of the decreased resistance in the piping network as parallel chillers are destaged. Refer to figure 4 where the correct sensor placement is shown.

Savings Example

Savings for a 40 HP/30 kW primary pump operated at 100% constant flow with an adjustable frequency drive.

Total annual operating hours:	24h x 365 days	=	8,760 hours
Energy consumption per year:	30 kW x 8,760 hours	=	262,800 kWh
Energy saved by using a drive:	15% of 262,800 kWh	=	39,420 kWh
Annual money saved using a drive:	39,420 kWh x \$ 0.10	=	\$ 3,942

Simple payback: $\frac{\text{Drive price}}{\text{Energy savings}} \approx 1.5\text{-}2.5 \text{ years}$

■ Comparison of installation and maintenance costs

In addition to the potential energy savings, the cost of an adjustable frequency drive is partially paid for by the savings on installation and maintenance. The traditional system not only requires throttling or balancing valves, but also needs a soft-starter and power factor correction capacitors. When opting to trim the pump impeller, system down time and a considerable amount of labor is expended.

With an adjustable frequency drive, the valves, soft-starter, and power factor corrections are unnecessary. Manual speed adjustment or feedback from a flow meter, as either voltage (0 to 10 V) or current (0 or 4 to 20 mA), is sufficient to manage the motor and pump speed. In addition, cost pay-back for the drive is almost immediate (see True Payback Calculation Example below).

The comparison of the energy consumption, installation costs, and decreased maintenance demonstrates why using an adjustable frequency drive is the most effective and practical choice for controlling the primary pump in primary/secondary pumping systems.

■ Danfoss VLT adjustable frequency drives

The Danfoss VLT® series adjustable frequency drives are designed with features tailored for energy efficiency and precision control. VLT series drives are the most effective means for pump control in HVAC water pumping systems.

PID controller

Closed loop primary pump control can be accomplished with the VLT's internal PID controller. The VLT 6000 can operate without dependence on a building automation system, eliminating the need for an additional PID controller and I/O modules. For the typical primary chilled water pumping application, a single feedback (input) signal from a flow meter in the chiller evaporator section discharge line is all

that is required. The VLT 6000 offers 38 units of measure to display the feedback and setpoint signals for unequalled HVAC system flexibility. In closed loop primary pump control, feedback and set point values could be displayed in units of flow, such as GPM or m³/h.

Motor soft start

The Danfoss VLT drive supplies the right amount of current to the motor to overcome load inertia and then brings the motor up to speed. This avoids full line power voltage being applied to a stationary primary pump motor, which generates high current and heat. Benefits from this inherent soft start drive feature are reduced thermal load and extended motor life, reduced mechanical stress on the system due to hydraulic shock, and quieter system operation.

Automatic restart

With auto restart selected, the VLT drive will automatically power-up after a tripout. This feature eliminates the need for manual reset of the drive and enhances automated operation for remotely controlled systems where having someone restart the drive manually is inconvenient or impractical.

High and low feedback warning

In closed loop operation, the selected high and low feedback values are monitored by the Danfoss VLT drive. The display shows a flashing high or low warning, when appropriate. The warning condition may indicate system problems such as low primary loop water flow and issue a warning prior to the chiller tripping in a freeze up condition.

True Payback Calculation Example

$$\frac{\text{Cost of drive + flow meter - (throttling valves + starter + wiring + PFCCs) - saving in}}{\text{Energy savings + annual maintenance}} \approx 0 \text{ year} \pm 0.5$$

Secondary Pumps in a Primary/Secondary Chilled Water Pumping Systems

■ Application

Secondary pumps in a primary/secondary chilled water pumping system are used to distribute the chilled water from the primary production loop to the loads. A primary/secondary pumping system allows constant flow to be maintained in the primary loop (for chiller operation) while meeting the

variable flow requirements of the secondary loop. Because the flow is variable in the secondary loop, the minimum effective Δ pressure can be maintained in the secondary loop to reduce system noise and improve efficiency.

■ Traditional design

The primary pumps in the traditional primary/secondary system design manage the flow requirements and pressure drop in the production loop only. Larger secondary pumps circulate the water throughout the rest of the system. Since they are decoupled from the primary loop by a common line, the secondary pumps have no minimum flow constraints and can use two-way valves to control the cooling coil, along with other energy saving methods, without complication to the primary pumping loop (see figure1).

The system curve defines the discharge pressure that the secondary pumps must produce to overcome system resistance in delivering water flow to the cooling coils. System resistance (the

system head loss) is due to the restrictions caused by piping, fittings, valves and coils in the water flow. The shape of the system curve S1 or S2 (see figure 2) is determined by the resulting increase or decrease in system resistance as flow changes.

The system curve can change position from curve S1 to curve S2 if the system resistance increases, requiring more pressure to achieve a given flow. This increase in resistance occurs as the two-way valves at the cooling coils stroke toward a closed position in response to a decrease in cooling requirements in the conditioned spaces. The combination of pump and system can only operate at the intersection of

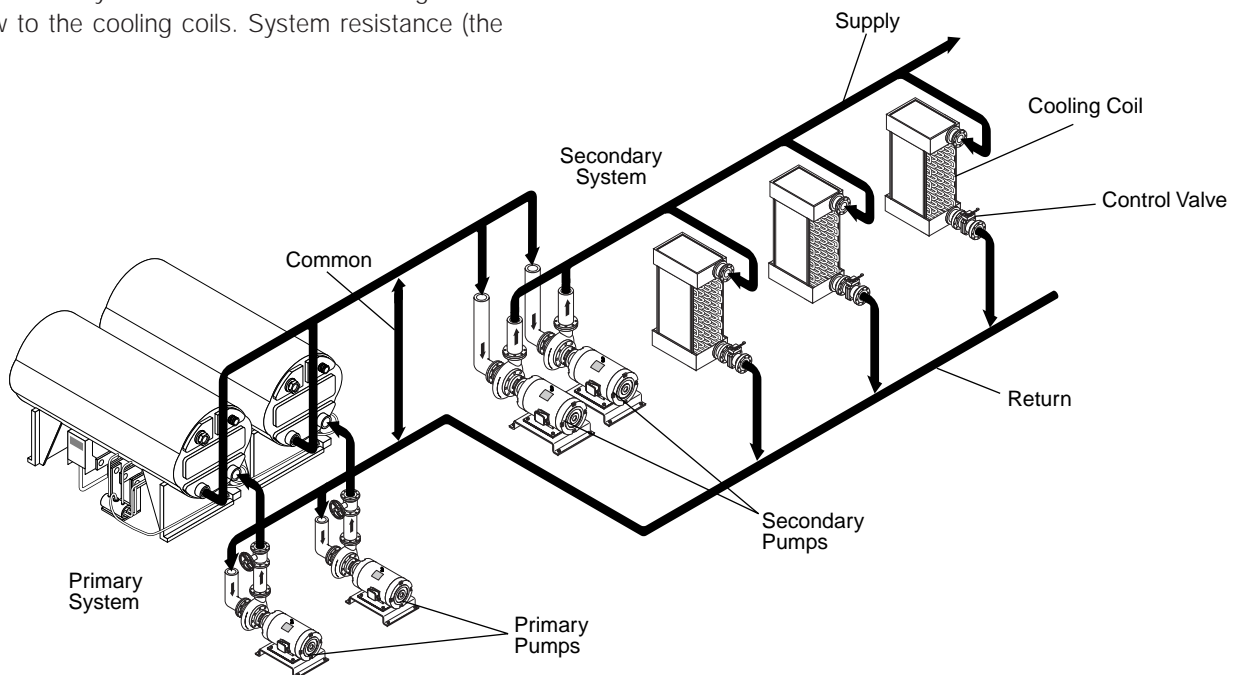

Figure 1. Primary/Secondary Pumping System

the pump curve and the system curve. A constant speed pump with two-way control valves must follow the pump curve from the Design pressure to pressure P1 (see figure 2) as the control valves decrease the flow. This means that, as the flow decreases, the pumps increase discharge pressure even though the system requires a lower discharge pressure.

The difference between pressure P1 and P2 is the pressure drop that the two-way valves must absorb. The pressure absorbed varies with the flow. This pressure can become greater than the valve is designed to operate against, forcing the valve to open. This can overcool the conditioned zones closest to the pump, while insufficiently cooling more distant ones, and can lead to a low ΔT condition for the chiller evaporator. The results are wasted energy, possible valve damage, inadequate system performance, and generally increased maintenance costs.

■ **Adjustable frequency drives**

Significant energy savings and increased control potential are realized by adding adjustable frequency drives to the secondary system, modifying it from variable volume with constant speed to variable volume with variable speed. Using drives (see figure 3), the pumps are controlled to vary their speed with the system requirements

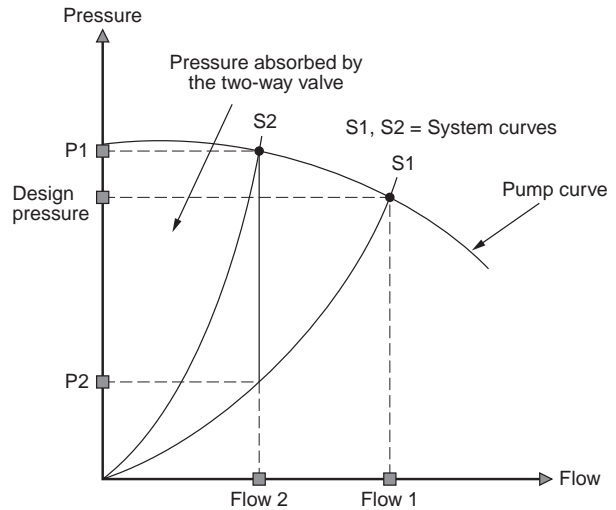

Figure 2. Pressure Absorbed by Two-way Valve

Figure 2 shows that as the system's flow requirement decreases from flow 1 to flow 2, the required pumping pressure is P2, but the constant speed pump produces P1. The difference in pressure is absorbed by the two-way valve.

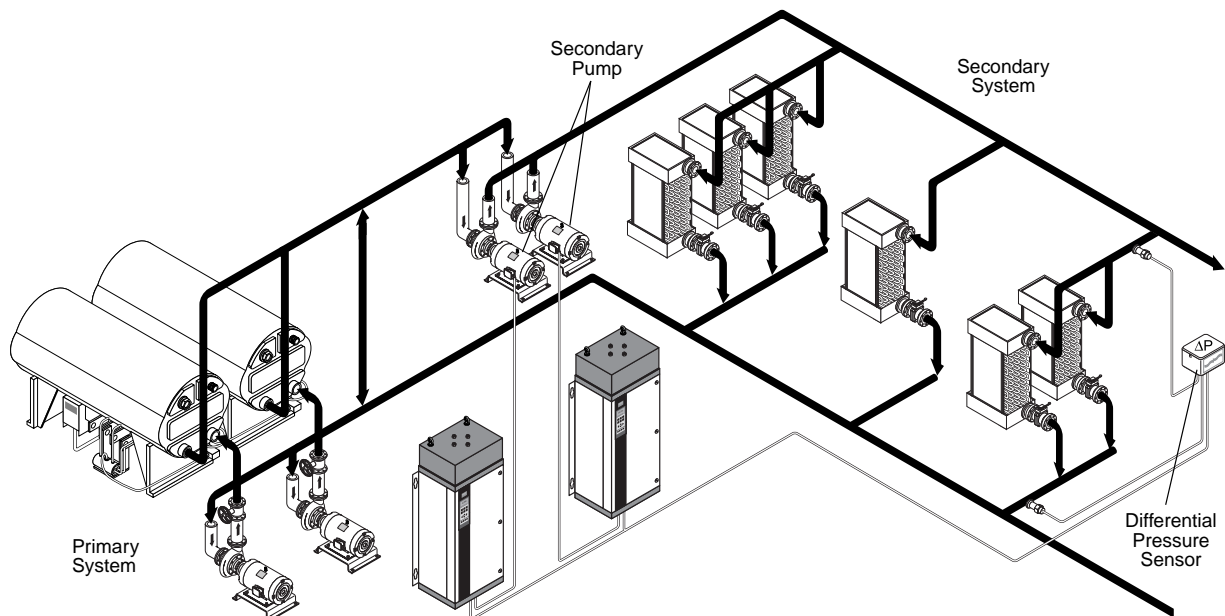

Figure 3. Secondary Pumping System with Adjustable Frequency Drives

(the system curve) instead of simply “riding” the pump curve. This operation following the system curve, results in optimum energy savings and eliminates the over-pressurization of the cooling coil two-way control valves that occurs when following the pump curve.

As the monitored cooling loads are satisfied, the two-way control valves move toward the closed position. This increases the differential pressure measured across the cooling coil and valve. As this differential pressure starts to rise, the drive slows the pump to maintain the DP setpoint value. This setpoint value is calculated by summing the pressure drop of the cooling coil, coil piping and two-way control valve together under design flow conditions.

With reduced speed, life of the pump and motor bearings is increased. Although the same cooling coil differential head is maintained in the individual air handling units, the overall system pressure and control valve DP is reduced. The resulting water velocity across the valve seat is significantly lower than if the pump were operating at constant, maximum speed. This increases valve life, reduces maintenance effort and reduces noise in the system.

Note that when multiple pumps are run in parallel, as in figure 3, they must run at the same speed to maximize energy savings and maintain balanced flow. This can be accomplished either with individually dedicated drives or with one drive running multiple pump motors.

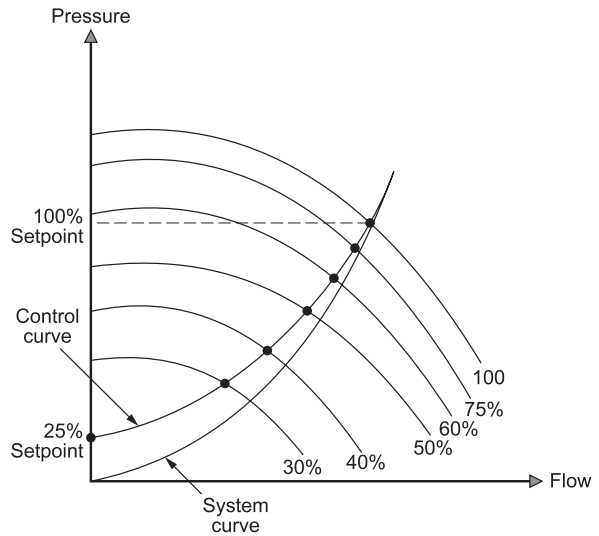

Figure 4. Variable Speed Pump Curves

■ **Specific energy consumption**

The way an adjustable frequency drive and variable speed pump respond to the system curve is shown in figure 4. The control curve shows the actual operation points of a secondary pump with variable speed control. The setpoint is the amount of pressure that must be maintained even at zero flow to satisfy system requirements, such as minimum pressure differential to operate the coils and control valves. The control curve represents the required increase in secondary pump discharge pressure to maintain the setpoint, as the friction loss in the pipe network increases with flow. The lower the setpoint, the greater the potential savings, as shown in figure 7 and 8.

■ **Annual operation load profile**

To calculate potential savings, look at the actual load profile. The load profile indicates the amount of flow the system requires to satisfy its loads during the day or time duration under study. Figure 5 shows a typical load profile for secondary chilled water pumps. Profiles vary depending on the specific needs of each system but the example represents actual systems.

■ **Energy savings calculation example**

In the calculation example below, a 40 HP/30 kW pump is operated according to the load profile shown in figure 5. The energy consumption during one year of operation compares a traditional system at constant speed and variable volume to a variable speed and variable volume system controlled by an adjustable frequency drive. The DP setpoint is 25% of the design pressure. The comparison demonstrates energy savings of nearly 33% with the adjustable frequency drive.

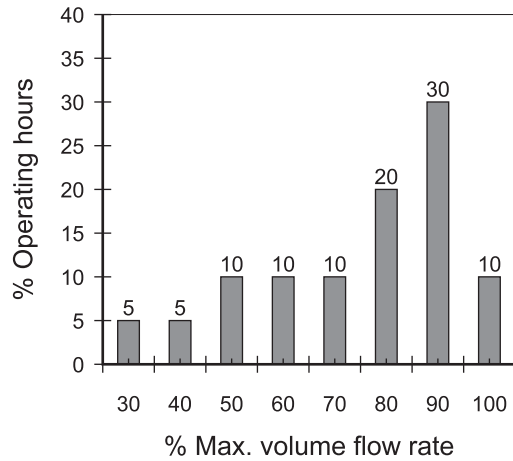

Figure 5. Operation Hours and Flow Rate

Energy Savings Table

Flow (%)	Hours (%)	Hours run	Electrical Power Required (kW)		Energy Consumption for 40 HP Pump Motor	
			Constant speed	VLT	Constant speed	VLT
30	5	438	23.33	4.73	10,219	2,073
40	5	438	23.56	6.08	10,321	2,663
50	10	876	24.03	8.01	21,047	7,014
60	10	876	24.71	10.61	21,647	9,298
70	10	876	25.62	14.04	22,441	12,300
80	20	1752	26.76	18.54	46,886	32,483
90	30	2628	28.17	24.28	74,027	63,814
100	10	876	30.22	31.48	26,470	27,573
	100%	8760 hrs			233,058 kWh	157,218 kWh

■ **Sensor type and placement**

The energy savings potential of an adjustable frequency drive system is clear. However, the importance of sensor type and placement on these energy savings should not be overlooked. To achieve optimum savings, it is critical to position sensors in the system correctly.

For secondary pumping systems, a differential pressure sensor should be used. The sensor detects the differential pressure across the load and the two-way control valve. It is important to place the sensor to measure the furthest, most significant load. This allows the drive's controller to take

advantage of the decreased resistance in the piping network, known as the variable head loss, as flow is reduced. With this sensor placement, the setpoint requirement drops to the static demand of the cooling coil and control valve.

Some installations have incorrectly located the differential pressure sensors in the supply and return headers or directly across the pump, usually to reduce installation costs. Figures 7 and 8 show the significant impact that sensor placement has on energy savings using the load profile described in figure 5.

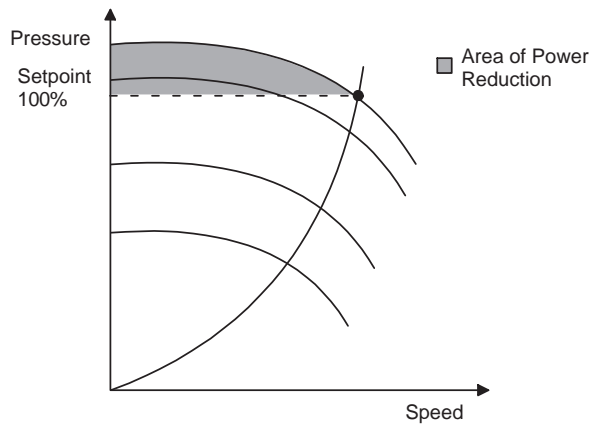
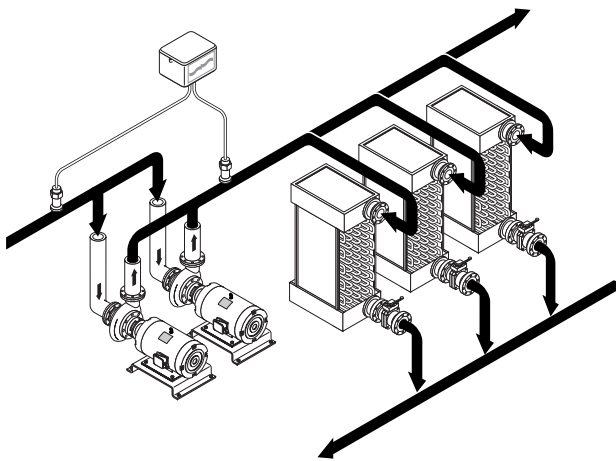

Energy consumption with 100% setpoint
 Total energy consumption per year: 220,942 kWh
 Annual savings: (12,116 x \$ 0.10) \$ 1,212

Figure 7. Sensor Location with 100% Setpoint

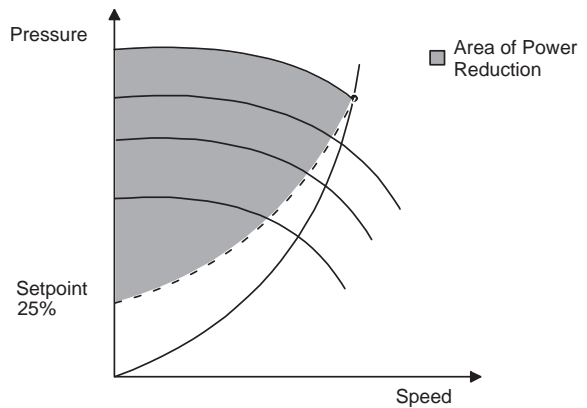
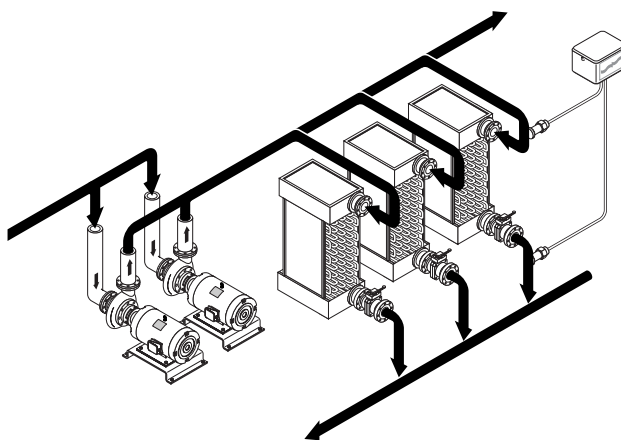

Energy consumption with 25% setpoint
 Total energy consumption per year: 157,218 kWh
 Annual savings: (75,840 x \$ 0.10) \$ 7,584

Figure 8. Sensor Location with 25% Setpoint

■ Danfoss VLT adjustable frequency drives

The Danfoss adjustable frequency drive offers the most effective means of controlling secondary loop pumps for maximum system efficiency, reduced complexity and increased energy and cost savings.

PID controller

VLT 6000 drives accommodate two feedback signals from two different devices resulting in a unique two setpoint capability. This feature allows regulating a system with different setpoint zones. The drive makes control decisions by comparing the two signals to optimize system performance. In figure 3, for example, two differential pressure transmitters could be applied to the VLT 6000 controlling the secondary pump capacity.

In some installations, there are major differences in system variable head losses from one load location to another, or the setpoints can be significantly different, such as in AHU coils vs. a fan coil. In controlling dissimilar loads, it is possible to place a differential pressure transmitter in each of two parallel piping runs and control to the “worst case” condition.

Motor soft start

The Danfoss VLT drive supplies the right amount of current to the motor to overcome load inertia and then brings the motor up to speed. This avoids full line power and voltage being applied to a stationary motor, which generates high current and heat. Benefits from this inherent soft start drive feature are reduced thermal load and extended motor life, reduced mechanical stress on the system due to hydraulic shock, and quieter system operation.

Automatic restart

With auto restart selected, the VLT drive will automatically power-up after a trip-out. This feature eliminates the need for manual reset of the drive and enhances automated operation for remotely controlled systems where having someone restart the drive manually is inconvenient or impractical.

High and low feedback warning

In closed loop operation, the selected high and low feedback values are monitored by the Danfoss VLT drive. The display shows a flashing high or flashing low warning, when appropriate. The warning condition may indicate system problems, such as a burst or constricted water pipe, or issue a warning prior to the chiller tripping due to a low flow or low load condition.